



Air conditioner
SERVICE MANUAL

Model

HSU-22LE03

CAUTION

READ THIS MANUAL CAREFULLY TO DIAGNOSE TROUBLE CORRECTLY BEFORE OFFERING SERVICE.

THIS MANUAL IS USED BY QUALIFIED APPLIANCE TECHNICIANS ONLY.

HAIER DOES NOT ASSUME ANY RESPONSIBILITY FOR PROPERTY DAMAGE OR PERSONAL INJURY FOR IMPROPER SERVICE PROCEDURES DONE BY ONE UNQUALIFIED PERSON.

CONTENTS

1. GENERAL INFORMATION.....	3
2. SPECIFICATION.....	5
3. ELECTRICAL CONTROL.....	7
4. TROUBLE SHOOTING.....	12
5. INSTALLATION.....	14
6. WIRING DIAGRAM.....	22
7. THERMISTER RESISTANCE CHART.....	24
8. COMPRESSOR PERFORMANCE DIAGRAM.....	30
9. SCHEMATIC DIAGRAM OF PCB.....	31

1. General information

This Service Manual describes the operation, disassembly, troubleshooting, and repair of Haier Room Air Conditioners, etc. It is intended for use by authorized services that troubleshoot and repair these units.

It is assumed that users of this manual are familiar with the use of tools and equipment used to troubleshoot and repair electrical, mechanical, and refrigeration systems; and understand the terminology used to describe and discuss them.

Haier urges you read and follow all safety precautions and warnings contained in this manual. Failure to comply with safety information may result in severe personal injury or death.

Related Publications

This is a base service manual, covering a range of similar models. It is intended to be used in conjunction with the Parts Manual and Technical Sheet covering specific model being serviced.

NOTE: General Precautions and Warnings

WARNING

To avoid risk of personal injury or death due to electrical shock, disconnect electrical power to unit before attempting to service the unit.

WARNING

To avoid risk of personal injury or death due to electrical shock, DO NOT, under any circumstances, alter the grounding plug. Air conditioner must be grounded at all times. Do not remove warning tag from power cord. If a two-prong (non-grounding) wall receptacle is encountered, contact a qualified electrician and have the receptacle replaced with a properly grounded wall receptacle in accordance with the National Electrical Code.

WARNING

To avoid risk of heat exposure, which may cause death or severe illness, air conditioner must be monitored when malfunctions or shuts down.

WARNING

To avoid risk of personal injury or death due to electrical shock, grounding wires and wires colored like grounding wires are NOT to be used as current carrying conductors. The standard accepted color coding for ground wires is green or green with a yellow stripe. Electrical components such as the compressor and fan motor are grounded through an individual wire attached to the electrical component and to another part of the air conditioner. Grounding wires should not be removed from individual components while servicing, unless the component is to be removed and replaced. It is extremely important to replace all removed grounding wires before completing service.

MODEL: HSU-22LE03

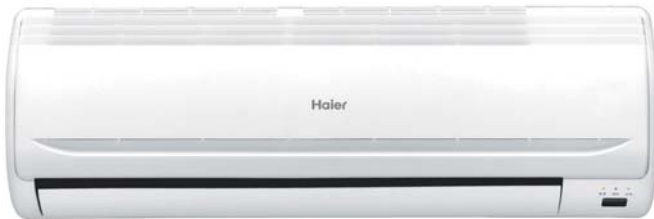

Product Features

- Comfortable: wide-angle airflow
- health air purifying
- quiet operation



Main Specification

- Cooling Capacity: 6200W
- Rated Power(cooling): 2350 W
- Rated Current(cooling): 11.3 A
- EER: 2.64

- Air Volume(Indoor/outdoor): 600 m³/h
- Power: 1PH/220V/50 Hz

2. Specification

Model:		HSU-22LE03
Power		1PH/220V/50Hz
Climate Type		T1
Cooling	Cooling Capacity (W)	6200
	Rated Power (W)	2350
	Rated Current (A)	11.3
	Max Power (W)	2950
	Max Current (A)	12.6
	EER (W/W)	2.64
Heating	Heating Capacity(W)	/
	Rated Power (W)	/
	Rated Current (A)	/
	Max Power (W)	/
	Max Current (A)	/
	COP (W/W)	/
Starting Current (A)		20
Operating temp. range (°C)	Cooling	18~46
	Heating	/
Class of electric Shock Protection		I
Class of Water Proof		IP24
Remote Controller Model		YL-M07
Power Cord (Model × Sectional Area)		3G2.5mm ² (VDEH05VV-F3)
Moisture Removal (10 ⁻³ m ³ /h)		2.4
Max. pressure at warm side (MPa)		2.8
Drainage pipe material diameter (mm)		25.5
Drain Hose	Length (mm)	580
	Diameter (mm)	25.5
Indoor fan Velocity	H (rpm)	1350
	M (rpm)	1250
	L (rpm)	1100
Outdoor fan Velocity	H (rpm)	860
Air Volume (High)	Indoor (m ³)	600
Compressor	Manufacture	RECHI
	Type	55R613GW-8ASM
	Compressor Oil Charge (ml)	710
Refrigerant	Type	R22
	Net Charge (g)	1400
	Charge if over standard pipe length (g/m)	16
Refrigerant Pipe	Liquid pipe Diameter (mm)	6.35
	Gas pipe Diameter (mm)	15.88
	Standard length (m)	5
	Max length (m)	15

Weight	Indoor	Net (kg)	11
		Gross (kg)	14
	Outdoor	Net (kg)	45
		Gross (kg)	50
Dimension	Indoor	Net (mm)	938×265×182
		Package (mm)	1020×308×323
	Outdoor	Net (mm)	780×250×650
		Package (mm)	908×342×712

3. ELECTRICAL CONTROL

1. Run mode

1.1 Automatic run mode (Tr: inlet air temperature, Ts: the set temperature)

The background lighting of the LCD is white

1) Cooling only type automatic run mode:

When the system runs under "automatic" mode for the first time, it will determine the operating mode according to the follows:

$Tr \geq Ts + 3^{\circ}\text{C}$ Choose Cooling mode

$Tr < Ts - 3^{\circ}\text{C}$ Choose Blowing Mode

The system will shift its operating mode between the above mentioned two to changes of the indoor temperature. If the system is currently under cooling mode, it will switch to blowing mode when $Tr < Ts - 3^{\circ}\text{C}$; if the system is currently under blowing mode, it will in turn switch to cooling mode when $Tr > Ts + 3^{\circ}\text{C}$.

1.2 Cooling run mode (Tr: inlet air temperature, Ts: the set temperature)

The background lighting of the LCD is blue

Temperature control range: $16^{\circ}\text{C} - 30^{\circ}\text{C}$

Temperature control precision: $\pm 1^{\circ}\text{C}$

Compressor can't be controlled by temperature sensor within 2 minutes after it starts.

Control character:

- when $Tr > Ts$, outdoor fan motor and compressor on, and indoor fan motor run at fixed wind speed.
- When $Tr < Ts$, outdoor fan motor and compressor off, and when $Tr > Ts$, outdoor fan motor and compressor are working again.
- If $Tr = Ts$, the indoor fan motor, outdoor fan motor and the compressor's state will not change.

Wind speed control: (the temperature difference is 1°C)

auto: when $Tr \geq Ts + 3^{\circ}\text{C}$, the wind speed is high;

when $Ts + 1^{\circ}\text{C} \leq Tr < Ts + 3^{\circ}\text{C}$, the wind speed is medium.

When $Tr < Ts + 1^{\circ}\text{C}$, the wind speed is low.

When temperature sensor is off, the fan motor runs at low speed.

when the wind speed changes from low to higher, there is no delay, and when it changes from high to lower, there is a 3-minutes delay before conversion.

Manual operation: When unit is on the wind speed can be set to high, medium, low automatic as required (execute instruction 2 seconds later after receiving remote signal)

Compressor control: The compressor can't be controlled by temperature sensor within 2 minutes after startup and can be only restarted at least 3 minutes later after shutdown.

There is no 3-minute protection with power on for the first time (over 3 minutes with power off).

The compressor must stand by for 3 minutes before it is restarted after shutdown. There is no 2-minute limit when changing the temperature setting or shutting down the machine through the remote controller, and the machine can be shut down immediately.

Control the position of air door: set the position of air door as required.

Protection of expiration of current peak value is available: Current cross detection is available in order to avoid burning out the compressor when the current is too big.

The action character as follows:

The compressor can't be detected in 60 seconds after startup. When current is above "CT 1.6 V" and lasts 3 seconds, the system enter protection mode and shut off compressor with outdoor air blower and indoor fan motor controlled as the temperature sensor is off. After 3 minutes the machine can be started again.

Protection of frost is available: In order to prevent the indoor heat exchanger from freezing (in cooling or dehumidifying mode), the compressor will be shut off when the temperature of the indoor coil pipe is or below 0°. And the compressor runs for over 5 minutes. When the temperature of the indoor coil pipe ascends to over 7°C, the compressor is restarted (must meet a 3-minutes delay) Timer on, Timer off and sleep control are available.

1.3 Dehumidifying mode: (Tr: inlet air temperature, Ts: the set temperature)

The background lighting of the LCD is aquamarine blue

Temperature control range : 16°C—30°C

Temperature control precision: $\pm 1^\circ\text{C}$

Control character:

When $Tr > Ts + 2^\circ\text{C}$, compressor and outdoor fan motor run continuously with indoor fan motor running in accordance with the wind speed setting.

When $Ts \leq Tr \leq Ts + 2^\circ\text{C}$, outdoor fan motor and compressor are on for 10 minutes and off for 6 minutes, the indoor fan motor is off in 3 minutes after shutdown of compressor and gives breeze in other time.

When $Tr < Ts$, outdoor fan motor and compressor are unavailable, and the indoor fan motor enter breeze mode 3 minutes later after shut down of compressor.

When all the ranges alternate, there is $\pm 1^\circ\text{C}$ difference.

Wind speed control:

Automation: When $Tr \geq Ts + 5^\circ\text{C}$, the wind speed is high.

When $Ts + 3^\circ\text{C} \leq Tr < Ts + 5^\circ\text{C}$, the wind speed is medium.

When $Ts + 2^\circ\text{C} \leq Tr < Ts + 3^\circ\text{C}$, the wind speed is low.

When $Ts \leq Tr < Ts + 2^\circ\text{C}$, the machine gives breeze intermittently.

When $Tr < Ts$, the indoor fan motor is shut off in 3 minutes

When $Tr < Ts$, the machine gives breeze after 3 minutes

Manual operation: When the temperature sensor is off or the indoor fan motor runs intermittently, the indoor fan motor can not be operated by hand (compelling automatic operation), along with the indoor fan motor can be operated in cooling mode. While

controlling fan motor by hand in cooling mode, the cooling ranges include wind speed setting and refrigeration range, others are the same as fan motor in automation mode.

Compressor control:

The compressor can't be controlled by temperature sensor in 2 minutes after startup and also can't be started again at least 3 minutes later after shutdown. There is 3-minutes protection with power on for the first time (over 3 minutes with power off). The compressor must be started again 3 minutes later after shutdown.

There is no 2-minutes limit when changing the temperature setting or shutting off the machine through the remote controller, and the machine can be shut down immediately.

Control the position of air door:

set the position of air door as required.

Protection of expiration of current peak value is available:

Current cross detection is available in order to avoid burning out the compressor when the current is too big.

The action character as follows:

The compressor can't be detected in 60 seconds after startup. when current is above "CT 1.6 V" and lasts 3 seconds, the system enter protection mode and shut off compressor with outdoor air blower and indoor fan motor controlled as the temperature sensor is off. After 3 minutes the machine can be started again.

Protection of frost is available (disable in test run or heating mode):

In order to prevent the indoor heat exchanger from freezing (in cooling or dehumidifying mode), the compressor will be shut off when the temperature of the indoor coil pipe is or below 0? And the compressor runs for over 5 minutes. When the temperature of the indoor coil pipe ascends to over 7°C, the compressor is restarted (must meet a 3-minutes delay) Timer on, Timer off and sleep control are available.

2. Control function

2.1 Timer function

You can set 24-hour timer on or timer off as required, and the minimum time unit is 1 minute. After setting, a pattern of clock displayed on the LCD, and it is off when timer setting is completed.

There are several timer modes as follows.

Timer on: The pattern of clock displayed on the LCD, the background light is off, and unit behaves with halt status. Timer on is completed, and then unit starts running with the pattern of clock disappeared, and the background light is on. The unit starts with the last setting receiving timer signals, and sleep setting is not allowed.

Timer off: Unit working, the pattern of clock displayed on the LCD. When reaching time setting, unit enters shutdown mode, and sleep function can be set. If timer off and sleep are set synchronously, the one which time is short run first. Executing shutdown instruction clear timer and sleep function.

Timer on and timer off can be set synchronously when they are completed,

2.2 Sleep function (saving function at night)

The pattern of clock displayed on the LCD In cooling/defrosting mode, the temperature setting increases 1°C? One hour later after startup. After another hour the temp setting increases by more 1°C? And then run continuously for another 6 hours and then close.

If the wind speed is set to high or medium before going to bed, the wind speed shifts to medium or low. If the wind speed is set to low before going to bed, the wind speed keep unchanged.

2.3 Protection of malfunction of temperature sensitive resistance.

The temperature sensitive resistor is short circuit or open circuit, the machine doesn't work.

- During defrosting, don't detect if the temperature sensor short circuit or open circuit.
- Detect the temperature of coil pipe is below -40°C? Then think the temperature circuit of coil pipe is open.
- Detect the temperature of coil pipe is above 95°C? Then think the temperature circuit of coil pipe is short.
- Detect the temperature of inlet air is below -20°C? Then think the temperature circuit of inlet air is open.
- Detect the temperature of inlet air is above 90°C? Then think the temperature circuit of inlet air is short.

2.4 Emergency switch input

Press the switch of emergency operation, then buzzer rings once and unit enters the automatic operation mode. (Emergency operation)

If the switch is pressed for 5 seconds and buzzer ring two times, unit enters into test run mode. Press the switch again, and then closes.

The unit can receive remote control.

Enter emergency operation from timer mode, and then timer is cancelled.

Test run:

1) The temperature sensor of inlet air doesn't work, and compressor starts (but subject to the limit of 3 minute delay excluding the first time), and high wind, cooling, and air door is open. The indoor fan motor runs, running indicator lights up, compressor relay and the one of outdoor fan motor is closed.

2) During test run:

The prevention of freezing of evaporator doesn't work.

Over current control doesn't work.

The control of current peak expiration doesn't work.

Temperature control doesn't work.

Temperature expiration control doesn't work.

The test run is over after 30 minutes, and then the unit turns off

2.5 Executive function after 2 seconds by remoter control

After receiving remote control signal, the mainboard doesn't enter the corresponding instruction task until 2 seconds elapse.

The memory function of power down is available, and the auto recovery function of



power on is optional. (In auto, heating, cooling, or defrosting status, press the “sleeping” button 10 times within 5 seconds, and the auto recovery function of power on can be set on/off. If the buzzer rings 4 times, the auto recovery function of power on is available; If the buzzer rings 2 times, the auto recovery function of power on is unavailable.)

2.6 Alarm from indoor fan motor

After 120 seconds the indoor fan motor is charged, and the impulse from fan motor is not detected, then stops outputting voltage to indoor fan motor, send alarm signals.

4. Trouble shooting

Before asking for service, check the following first.

	Phenomenon	Cause or check points
Normal Performance inspection	The system does not restart immediately. 	<ul style="list-style-type: none"> ● When unit is stopped, it won't restart immediately until 3 minutes have elapsed to protect the system. ● When the electric plug is pulled out and reinserted, the protection circuit will work for 3 minutes to protect the air conditioner.
	Noise is heard. 	<ul style="list-style-type: none"> ● During unit operation or at stop, a swishing or gurgling noise may be heard. At first 2-3 minutes after unit start, this noise is more noticeable. (This noise is generated by refrigerant flowing in the system.) ● During unit operation, a cracking noise may be heard. This noise is generated by the casing expanding or shrinking because of temperature changes. ● Should there be a big noise from air flow in unit operation; air filter may be too dirty.
	Smells are generated.	<ul style="list-style-type: none"> ● This is because the system circulates smells from the interior air such as the smell of furniture, cigarettes.
	Mist or steam is blown out.	<ul style="list-style-type: none"> ● During COOL or DRY operation, indoor unit may blow out mist. This is due to the sudden cooling of indoor air.
Multiple check	Does not work at all.	<ul style="list-style-type: none"> ● Is power plug inserted? ● Is there a power failure? ● Is fuse blown out?
	Poor cooling 	<ul style="list-style-type: none"> ● Is the air filter dirty? Normally it should be cleaned every 15 days. ● Are there any obstacles before inlet and outlet? ● Is temperature set correctly? ● Are there some doors or windows left open? Is there any direct sunlight through the window during the cooling operation?(Use curtain) ● Are there too much heat sources or too many people in the room during cooling operation?

- bright
 ★ flash
 ■ dark

lights indication			reasons	ways and means	solutions	tools
power	time	run				
★	■	■	Sensor is shorted out or opened circuit	Check the sensor of indoor ambient temperature if the resistance value is 0 or, the sensor is abnormal.	Change the sensor	Multimeter
★	□	□	Sensor is shorted out or opened circuit	Check the sensor of indoor coil pipe if the resistance value is 0 or, the sensor is abnormal.	Change the sensor	Multimeter
■	□	★	Indoor fan motor don't feed back	check whether indoor motor has 80~170V voltage, if it has, wiring board is normal, then check whether the optical SCR is good, replace it if it is has flaw; else check whether there are something wrong with connecting line indoor fan motor capacitor and coil assembly	Change the capacitor or optical SCR or connecting line or indoor PCB	Multimeter
★	□	★	Data error or no EEPROM	Check whether the EEPROM is installed properly	Change the EEPROM	Multimeter and electric iron

5. Installation







- Read this manual before installation
- Explain sufficiently the operating means to the user according to this manual.

Necessary Tools for Installation

- | | | | |
|---------------------------|---------------------------------|--|-----------|
| 1.Driver | 5.Torque wrench(17mm,22mm,26mm) | 9.Nipper | 12.Reamer |
| 2.Hacksaw | 6.Pipe cutter | 10.Gas leakage detector or soap-and-water solution | |
| 3.Hole core drill | 7.Flaring tool | 11.Measuring tape | |
| 4.Spanner(17,19 and 26mm) | 8.Knife | | |

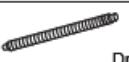
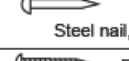
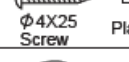
Drawing for the installation of indoor and outdoor units

Accessory parts

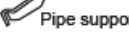
No.	Accessory parts	Number of articles
①	Remote controller	1
②	 R-03 dry battery	2
③	 Mounting plate	1
④	 Drain hose	1
⑤	 $\phi 4 \times 50$ Steel nail, cement	6
⑥	 $\phi 4 \times 25$ Screw Plastic cap	4
⑦	 Drain-elbow	1
⑧	 Cover	1
⑨	 Cushion	4
⑩	 Pipe supporting plate	1

Optional parts for piping

Mark	Parts name
(A)	Non-adhesive tape
(B)	Adhesive tape
(C)	Saddle(L.S) with screws
(D)	Connecting electric cable for indoor and outdoor
(E)	Drain hose
(F)	Heating insulating material
(G)	Piping hole cover

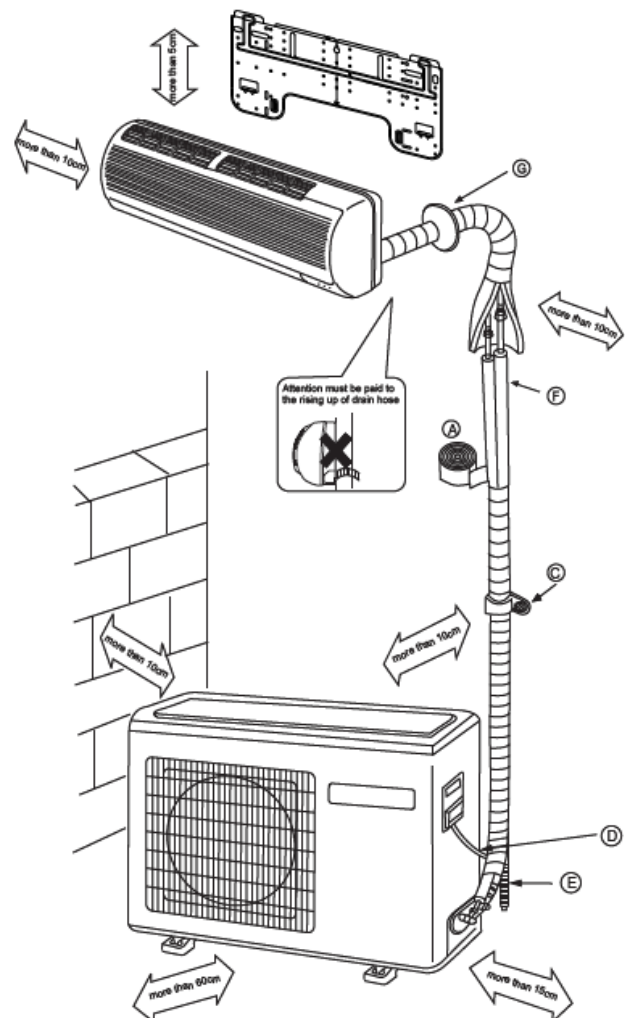
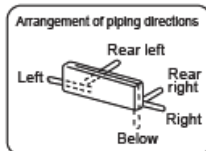

Note: Cooling only units don't have Drain-elbow

- ※ The marks from (A) to (G) in the figure are the parts numbers.
- ※ The distance between the indoor unit and the floor should be more than 2m.

No.0010561651

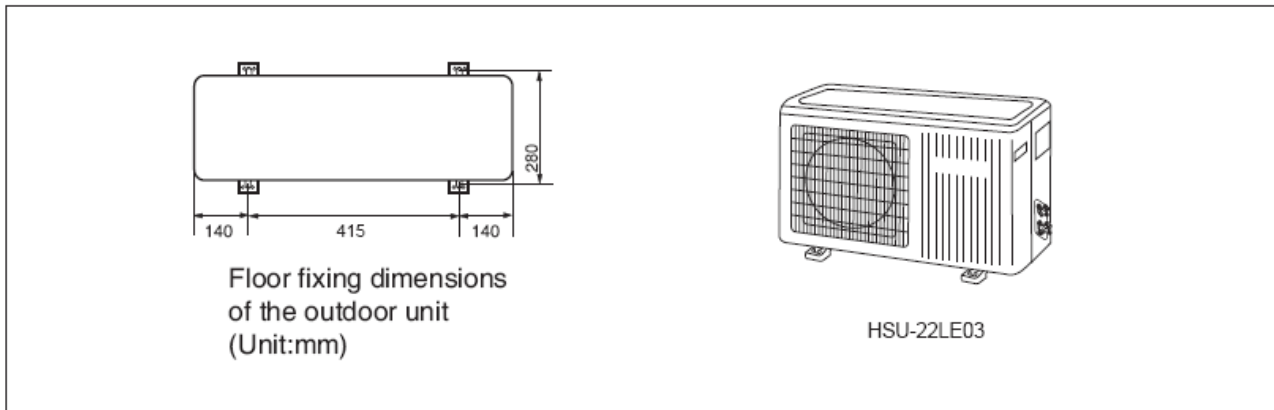

Floor fixing dimensions of the outdoor unit (Unit:mm)

HSU-22LE03

Fixing of outdoor unit

- Fix the unit to concrete or block with bolts(φ10mm) and nuts firmly and horizontally.
- When fitting the unit to wall surface, roof or rooftop, fix a supporter surely with nails or wires in consideration of earthquake and strong wind.
- If vibration may affect the house, fix the unit by attaching a vibration-proof mat.

Indoor Unit

Selection of Installation Place

Outdoor Unit

- Place, robust not causing vibration, where the body can be supported sufficiently.
- Place, not affected by heat or steam generated in the vicinity, where inlet and outlet of the unit are not disturbed.
- Place, possible to drain easily, where piping can be connected with the outdoor unit.
- Place, where cold air can be spread in a room entirely.
- Place, nearby a power receptacle, with enough space around. (Refer to drawings).
- Place where the distance of more than 1m from televisions, radios, wireless apparatuses and fluorescent lamps can be left.
- In the case of fixing the remote controller on a wall, place where the indoor unit can receive signals when the fluorescent lamps in the room are lightened.
- Place, which is less affected by rain or direct sunlight and is sufficiently ventilated.
- Place, possible to bear the unit, where vibration and noise are not increased.
- Place, where discharged wind and noise do not cause a nuisance to the neighbors.
- Place, where a distance marked ⇔ is available as illustrated in the above figure.

Power Source

- Before inserting power plug into receptacle, check the voltage without fail. The power source is the same as the corresponding name plate.
- Install an exclusive branch circuit of the power.
- A receptacle shall be set up in a distance where the power cable can be reached. Do not extend the cable by cutting it.

Selection of pipe

- To this unit, both liquid and gas pipes shall be insulated as they become low temperature in operation.
- Use optional parts for piping set or pipes covered with equivalent insulation material.
- The thickness of the pipe must be 0.8 mm at least.

	HSU-18LE03	
Liquid pipe(φ)	6.35mm(1/4")	
Gas pipe(φ)	12.7mm(1/2")	

Indoor Unit

1. Fitting of the Mounting Plate and Positioning of the wall Hole

When the mounting plate is first fixed

1. Carry out, based on the neighboring pillars or lintels, a proper leveling for the plate to be fixed against the wall, then temporarily fasten the plate with one steel nail.
2. Make sure once more the proper level of the plate, by hanging a thread with a weight from the central top of the plate, then fasten securely the plate with the attachment steel nail.
3. Find the wall hole location A using a measuring tape

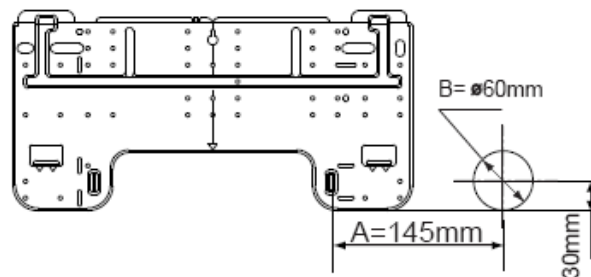

When the mounting plate is fixed side bar and lintel

- Fix to side bar and lintel a mounting bar, Which is separately sold, and then fasten the plate to the fixed mounting bar.
- Refer to the previous article, " **When the mounting plate is first fixed** ", for the position of wall hole.

2. Making a Hole on the Wall and Fitting the Piping Hole Cover

- Make a hole of 60 mm in diameter, slightly descending to outside the wall.
- Install piping hole cover and seal it off with putty after installation

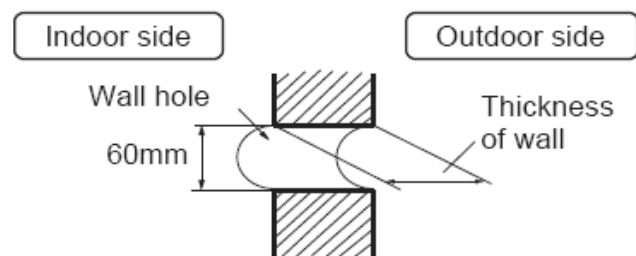

(Section of wall hole) ③ Piping hole pipe

3. Installation of the Indoor Unit

Drawing of pipe

[Rear piping]

- Draw pipes and the drain hose, then fasten them with the adhesive tape

[Left • Left-rear piping]

- In case of left side piping, cut away, with a nipper, the lid for left piping.
- In case of left-rear piping, bend the pipes according to the piping direction to the mark of hole for left-rear piping which is marked on heat insulation materials.

1. Insert the drain hose into the dent of heat insulation materials of indoor unit.
2. Insert the indoor/outdoor electric cable from backside of indoor unit, and pull it out on the front side, then connect them.
3. Coat the flaring seal face with refrigerant oil and connect pipes.
Cover the connection part with heat insulation materials closely, and make sure fixing with adhesive tape

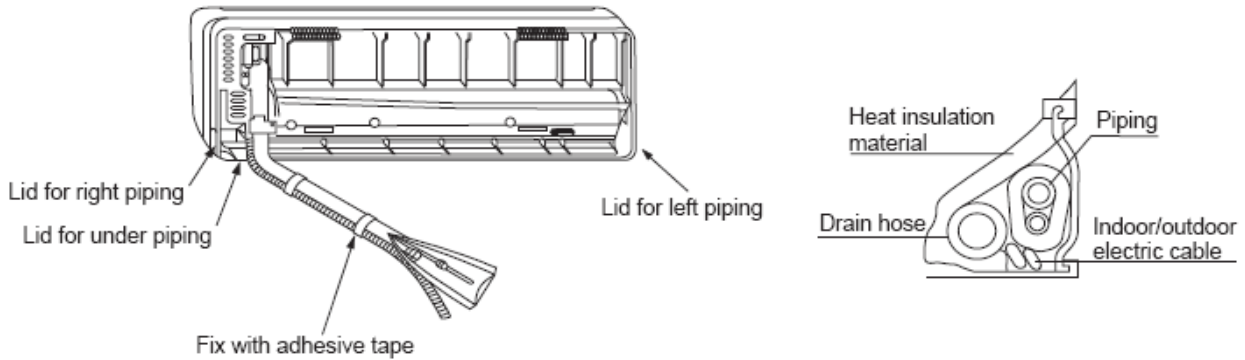

- Indoor/outdoor electric cable and drain hose must be bound with refrigerant piping by protecting tape.

[Other direction piping]

- Cut away, with a nipper, the lid for piping according to the piping direction and then bend the pipe according to the position of wall hole. When bending, be careful not to crash pipes.
- Connect beforehand the indoor/outdoor electric cable, and then pull out the connected to the heat insulation of connecting part specially.

Fixing the indoor unit body

- Hang surely the unit body onto the upper notches of the mounting plate. Move the body from side to side to verify its secure fixing.
- In order to fix the body onto the mounting plate, hold up the body aslant from the underside and then put it down perpendicularly.

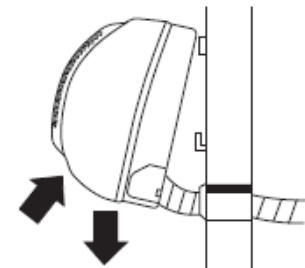

4. Connecting the indoor/outdoor Electric Cable

Removing the wiring cover

- Remove terminal cover at right bottom corner of indoor unit, then take off wiring cover by removing its screws.

When connecting the cable after installing the indoor unit

1. Insert from outside the room cable into left side of the wall hole, in which the pipe has already existed.
2. Pull out the cable on the front side, and connect the cable making a loop.



When connecting the cable before installing the indoor unit

- Insert the cable from the back side of the unit, then pull it out on the front side.
- Loosen the screws and insert the cable ends fully into terminal block, then tighten the screws.
- Pull the cable slightly to make sure the cables have been properly inserted and tightened.
- After the cable connection, never fail to fasten the connected cable with the wiring cover.

Note: When connecting the cable, confirm the terminal number of indoor and outdoor units carefully. If wiring is not correct, proper operation can not be carried out and will cause defect.

1. If the supply cord is damaged, it must be replaced by the manufacturer or its service agent or a similar qualified person. The type of connecting wire is H05RN-F or H07RN-F.
2. If the fuse on PC board is broken please change it with the type of T. 3.15A/250V.
3. The wiring method should be in line with the local wiring standard.
4. After installation, the power plug should be easily reached.
5. A breaker should be incorporated into fixed wiring. The breaker should be all-pole switch and the distance between its two contacts should be not less than 3mm.

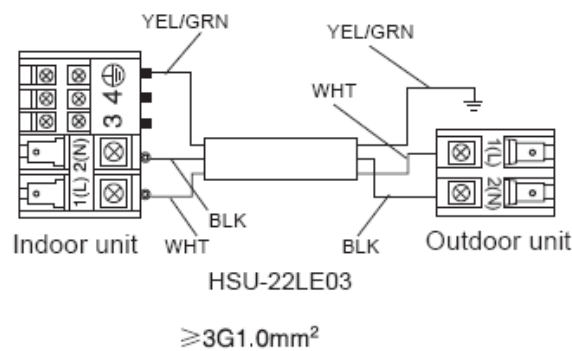
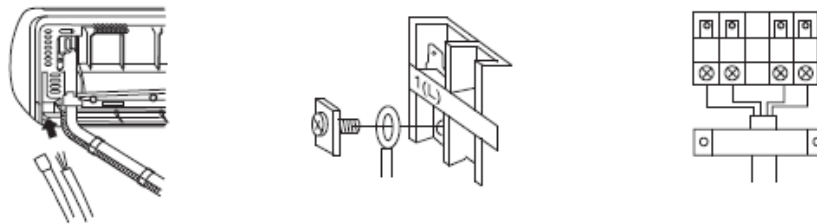

Connecting wiring:
-mod 09-12: *3G1.0mm²

Power cable:
-mod 09-12: *3G1.0mm²

Outdoor Unit

1. Installation of Outdoor Unit

Install according to Drawing for the installation of indoor and outdoor units

2. Connection of pipes

- To bend a pipe, give the roundness as large as possible not to crush the pipe
- Connecting the pipe of gas side first makes working easier.
- The max vertical distance between the indoor unit and the outdoor unit is 5 m.

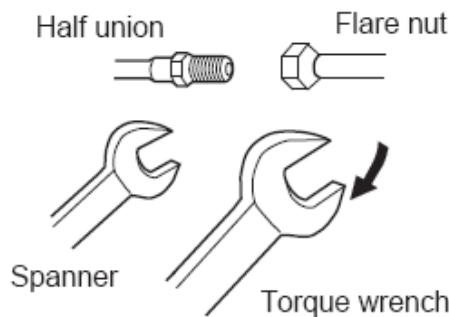

Forced fastening without careful centering may damage the threads and cause a leakage of gas.

Pipe Diameter (ϕ)	Fastening torque
Liquid side 6.35mm(1/4")	18N.m
Gas side 9.52mm(3/8")	40N.m
Gas side 12.7mm(1/2")	55N.m
Gas side 15.88mm(5/8")	60N.m

Be careful that matters, such as wastes of sands, etc. shall not enter the pipe.

3. Connection

- Use the same method on indoor unit. Loosen the screws on terminal block and insert the plugs fully into terminal block, then tighten the screws.
- Insert the cable according to terminal number in the same manner as the indoor unit.
- If wiring is not correct, proper operation can not be carried out and controller may be damaged.
- Fix the cable with a clamp.

4. Attaching Drain-Elbow

- If the drain-elbow is used, please attach it as figure. (Note: Only for heat pump unit.)



5.Purging Method:

Push the air out of the indoor unit and piping as follows:

- (1) Remove the valve cap on 2-way valve in outdoor unit.
- (2) Loosen by 1/2 turn the flare nut of gas pipe, which is conneted to 3-way valve.
- (3) Loosen 2-way valve by 90° using hexagon wrench, and after approx. 10 sec tighten it up. Gas comes out through flare nut on wide pipe. If no gas is discharged, tighten flare nut with specified torque.
- (4) Open 2-way and 3-way valves using specified torque.
- (5) Tighten the caps on the valves with specified torque.

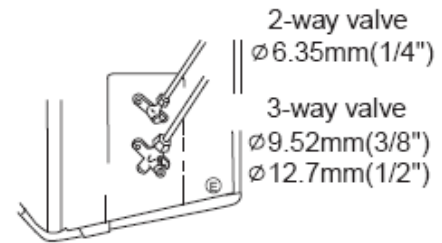

HSU-22LE03

	Tighten torque N.m
Valve rod	7-9
Valve cap	20-25

- When connecting pipe exceeds 5 meters, 16g refrigerant shall be added per exceeding meter. Charge according to the following list.

Piping length	5m	7m	10m
Additional amount	No need	32g	80g

- Note: When extending piping, air inside piping shall be removed by using external refrigerant gas, charge according to the following list.

Brand new outdoor unit is charged 50g more refrigerant than regulated weight. Only for first installation, this extra 50g can be used to purge air in pipes.

- ★ 1 During this procedure, 50g refrigerant will be discharged in piping.
(This must be strictly controlled within 90° and 10 sec.)

1. Power Source Installation

- The power source must be exclusively used for air conditioner. (Over 10A)
- In the case of installing an air conditioner in a moist place, please install an earth leakage breaker.
- For installation in other places, use a circuit breaker as far as possible.

2. Cutting and Flaring Work of Piping

- Pipe cutting is carried out with a pipe cutter and burs must be removed.
- After inserting the flare nut, flaring work is carried out.

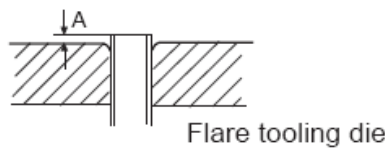

	Pipe diameter(ϕ)	Size A(mm)
Liquid side	6.35mm(1/4")	0.8~1.5
Gas side	9.52mm(3/8")	1.0~1.8
Gas side	12.7mm(1/2")	1.2~2.0
Gas side	15.88mm(5/8")	1.4~2.2

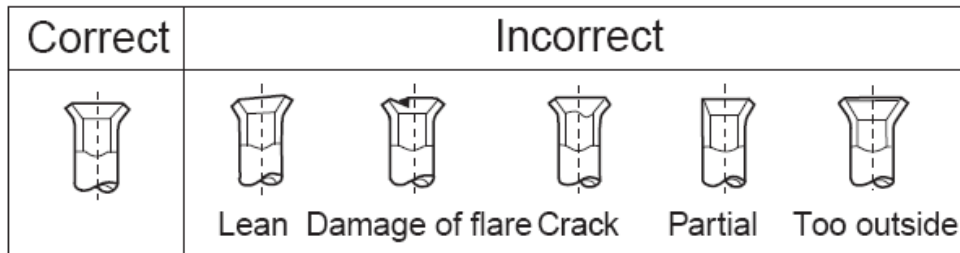

3. On Drainage

Please install the drain hose so as to be downward slope without fail.
Please don't do the drainage as shown below.

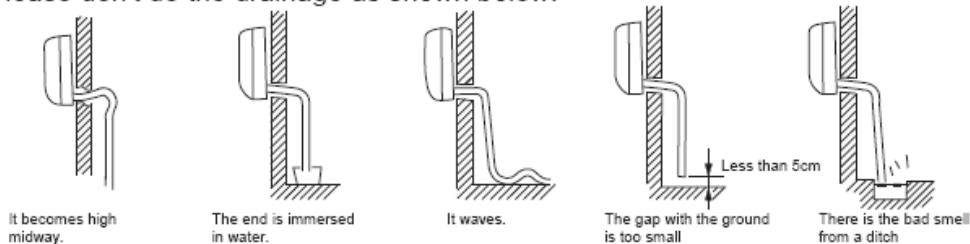

- Please pour water in the drain pan of the indoor unit, and confirm that drainage is carried out surely to outdoor.
- In case that the attached drain hose is in a room, please apply heat insulation to it without fail.

Check for Installation and Test Run

- Please kindly explain to our customers how to operate through the instruction manual.

Check Items for Test Run

Put check mark \checkmark in boxes

- | | | |
|--|--|--|
| <input type="checkbox"/> Gas leak from pipe connecting? | <input type="checkbox"/> Is drainage securely carried out? | <input type="checkbox"/> Is the lamp normally lighting? |
| <input type="checkbox"/> Heat insulation of pipe connecting? | <input type="checkbox"/> Is the earth line securely connected? | <input type="checkbox"/> Are cooling and heating (when in heat pump) performed normally? |
| <input type="checkbox"/> Are the connecting wirings of indoor and outdoor firmly inserted to the terminal block? | <input type="checkbox"/> Is the indoor unit securely fixed? | <input type="checkbox"/> Is the operation of room temperature regulator normal? |
| <input type="checkbox"/> Is the connecting wiring of indoor and outdoor firmly fixed? | <input type="checkbox"/> Is power source voltage abided by the code? | |
| | <input type="checkbox"/> Is there any noise? | |

6. Wiring diagram

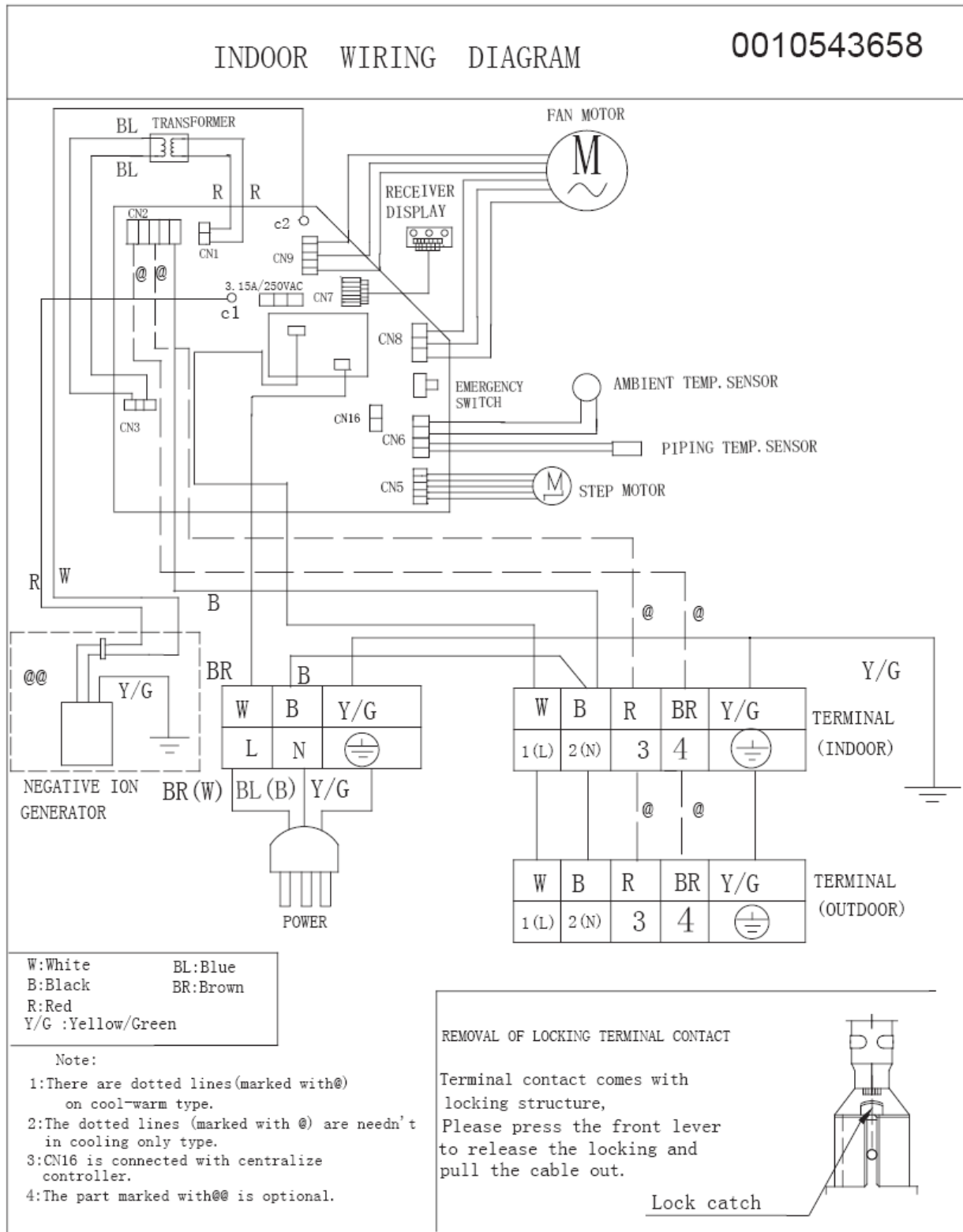

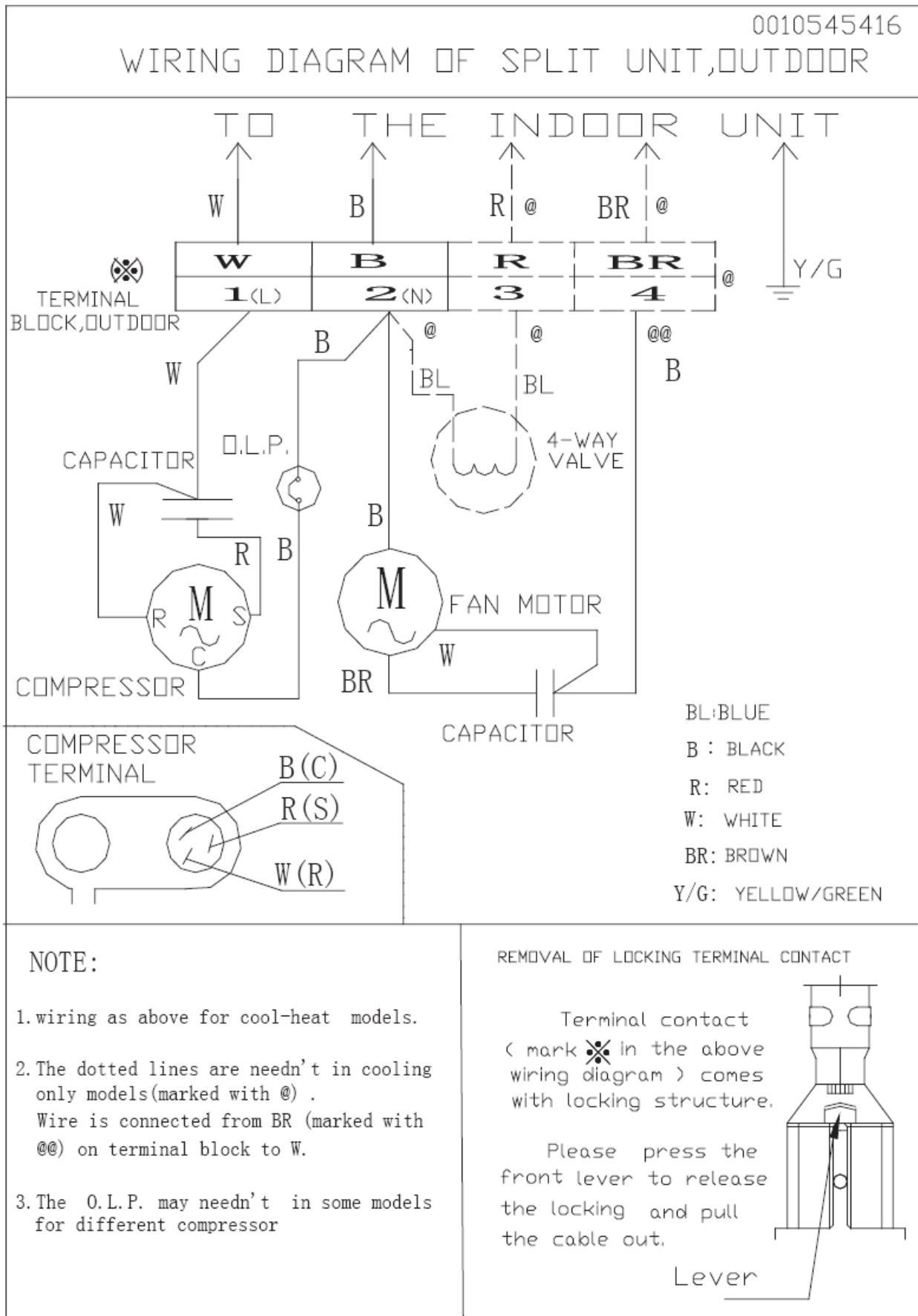

7. Thermistor resistance chart

Room temperature sensor

T(°C)	R(KΩ)
-20	251.8
-19	236.9
-18	223.1
-17	210.1
-16	197.9
-15	186.5
-14	175.9
-13	165.9
-12	156.5
-11	147.7
-10	139.5
-9	131.8
-8	124.5
-7	117.7
-6	111.3
-5	105.3
-4	99.63
-3	94.3
-2	89.3
-1	84.58
0	80.14
1	75.96
2	72.02
3	68.31
4	64.81
5	61.51
6	58.39
7	55.45
8	52.68
9	50.06
10	47.58
11	45.24
12	43.02
13	40.93
14	38.95
15	37.08
16	35.31
17	33.63
18	32.04

19	30.53
20	29.1
21	27.75
22	26.47
23	25.25
24	24.1
25	23
26	21.96
27	20.97
28	20.03
29	19.14
30	18.3
31	17.49
32	16.73
33	16
34	15.3
35	14.65
36	14.02
37	13.42
38	12.85
39	12.31
40	11.79
41	11.3
42	10.83
43	10.39
44	9.96
45	9.553
46	9.165
47	8.794
48	8.441
49	8.103
50	7.78
51	7.472
52	7.178
53	6.897
54	6.628
55	6.371
56	6.125
57	5.889
58	5.664
59	5.449
60	5.243
61	5.046
62	4.857

63	4.676
64	4.502
65	4.336
66	4.177
67	4.024
68	3.878
69	3.738
70	3.603
71	3.474
72	3.35
73	3.231
74	3.117
75	3.008
76	2.903
77	2.802
78	2.705
79	2.611
80	2.522

Indoor pipe temperature sensor

T(°C)	R(KΩ)
-30	155.4
-29	146.4
-28	138.1
-27	130.2
-26	122.9
-25	116
-24	109.5
-23	103.5
-22	97.77
-21	92.44
-20	87.42
-19	82.71
-18	78.29
-17	74.12
-16	70.21
-15	66.52
-14	63.06
-13	59.79
-12	56.71
-11	53.81
-10	51.08

-9	48.5
-8	46.07
-7	43.77
-6	41.6
-5	39.55
-4	37.62
-3	35.79
-2	34.06
-1	32.43
0	30.88
1	29.42
2	28.03
3	26.72
4	25.48
5	24.3
6	23.18
7	22.12
8	21.12
9	20.17
10	19.26
11	18.4
12	17.59
13	16.81
14	16.08
15	15.38
16	14.71
17	14.08
18	13.48
19	12.91
20	12.36
21	11.84
22	11.35
23	10.88
24	10.43
25	10
26	9.592
27	9.204
28	8.833
29	8.479
30	8.141
31	7.819
32	7.511
33	7.217
34	6.936

35	6.668
36	6.411
37	6.166
38	5.931
39	5.707
40	5.492
41	5.287
42	5.09
43	4.902
44	4.722
45	4.549
46	4.383
47	4.225
48	4.073
49	3.927
50	3.788
51	3.654
52	3.525
53	3.402
54	3.283
55	3.17
56	3.061
57	2.956
58	2.855
59	2.759
60	2.666
61	2.577
62	2.491
63	2.408
64	2.329
65	2.253
66	2.179
67	2.108
68	2.04
69	1.975
70	1.912
71	1.851
72	1.193
73	1.737
74	1.682
75	1.63
76	1.58
77	1.531
78	1.484

79	1.439
80	1.395
81	1.353
82	1.313
83	1.274
84	1.236
85	1.2
86	1.164
87	1.13
88	1.098
89	1.066
90	1.035

8. Compressor performance diagram

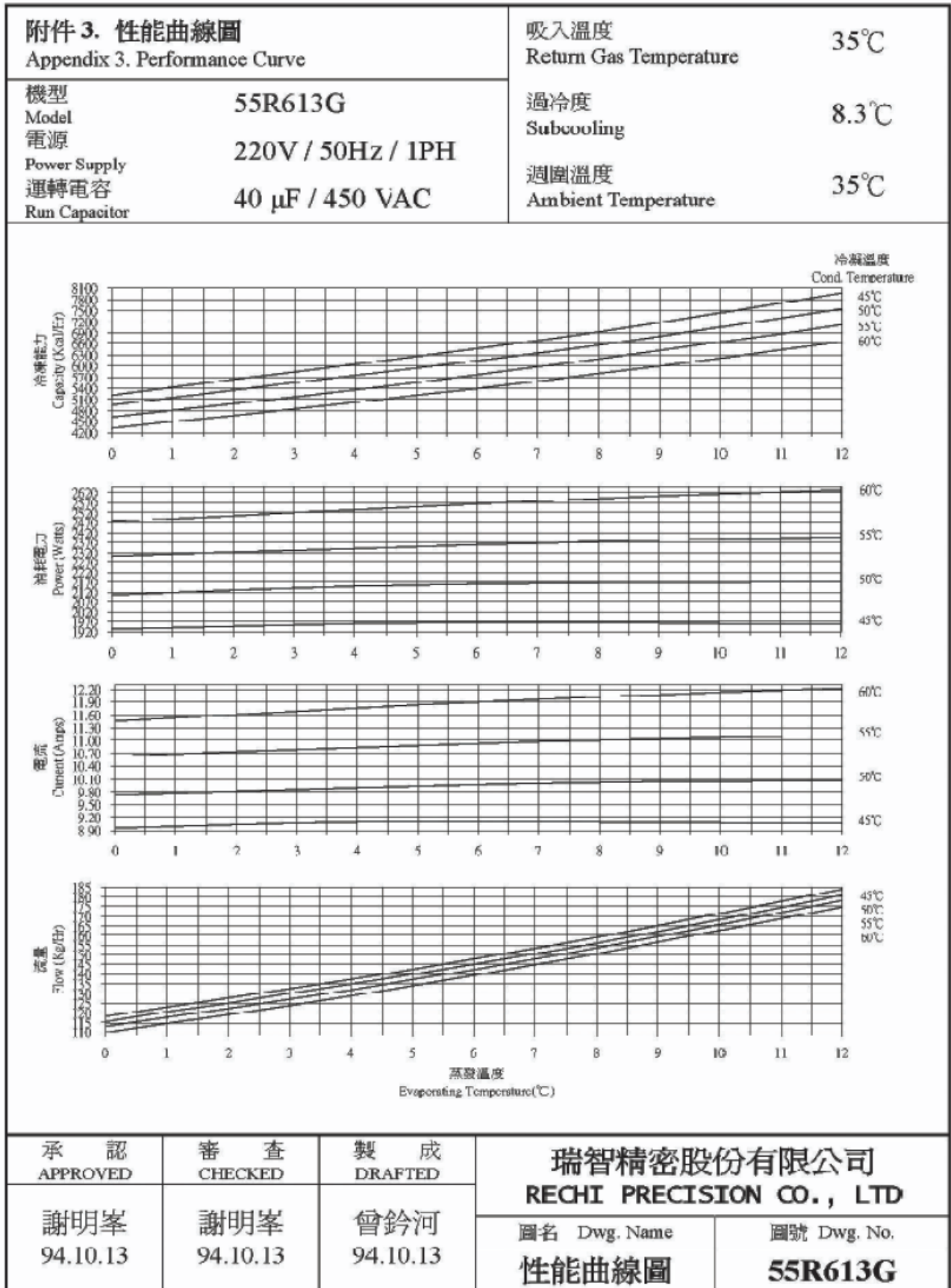

9. Schematic diagram of PCB

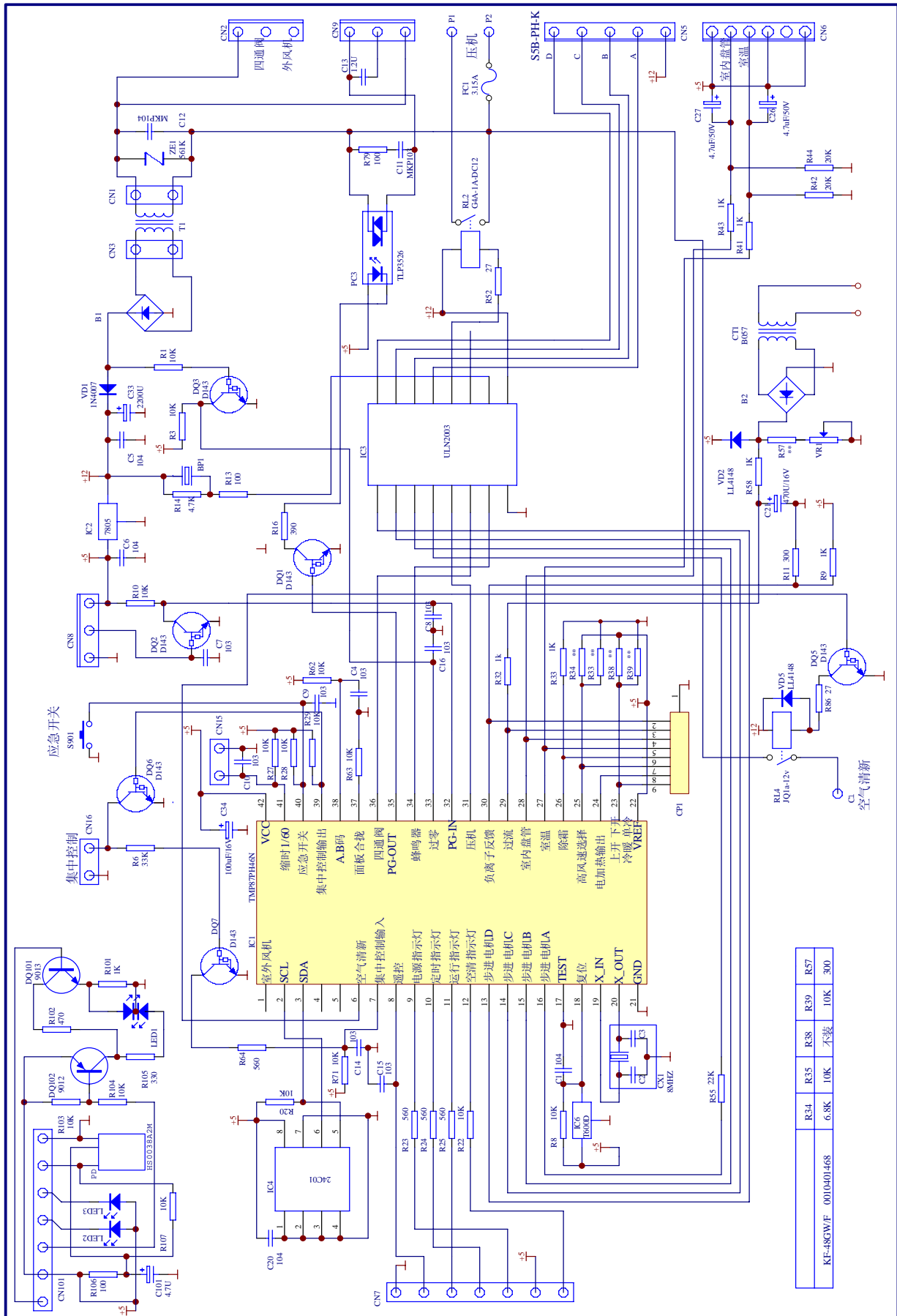

KF-862WF-0010401468	R34	R35	R38	R39	R57
	6.8K	10K	不装	10K	300

Sincere Forever

Haier Group

Haier Industrial Park, No.1, Haier Road

266101, Qingdao, China

<http://www.haier.com>