

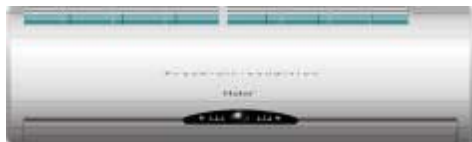

Domestic Air Conditioner

SERVICE MANUAL



Models

HSU-09RA03

HSU-12RA03

● Features

- Oxygen bar function
- health air purifying
- quiet operation
- energy efficient

DESCRIPTION OF PRODUCT MODEL CODING & SERIES INTRODUCTION

Introductory Remarks

A. Description of coding rules of unit model

Coding rules and descriptions of new models are as follows:

Indoor unit model and outdoor unit model of exported air conditioners shall be separately worked out in 10 digits combining English letters and Arabian numbers. The composition and representation are

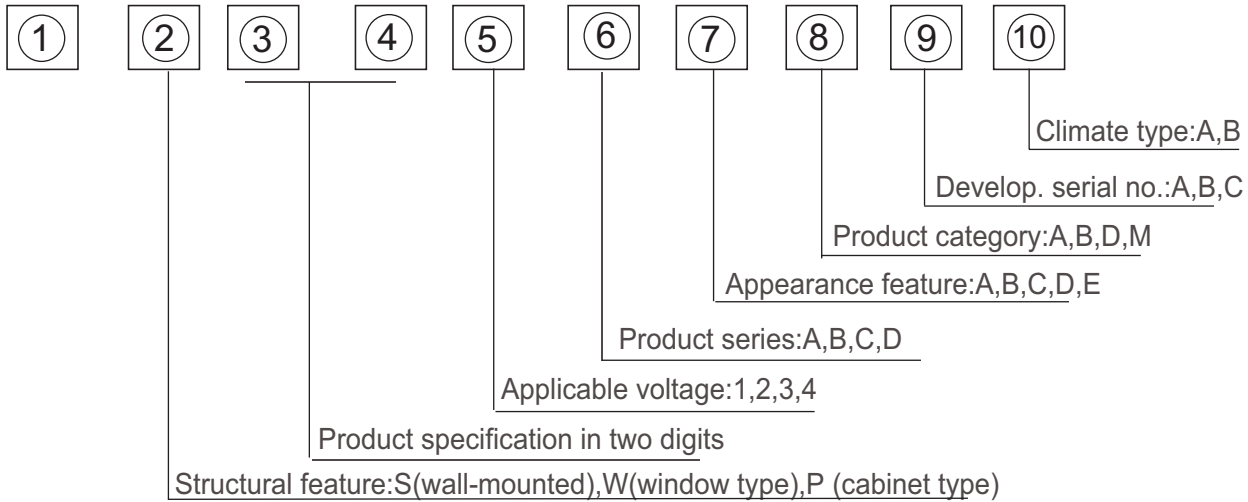

H-Abbreviation of Haier

Examples:

HSU-09RA03, It represents wall-mounted split type heat pump air conditioner. The cooling capacity is 9000BTU/h, and the power supply is 220-230V/50Hz, "A" means the developing sequence, and the refrigerant is R22.

B. Another model identification

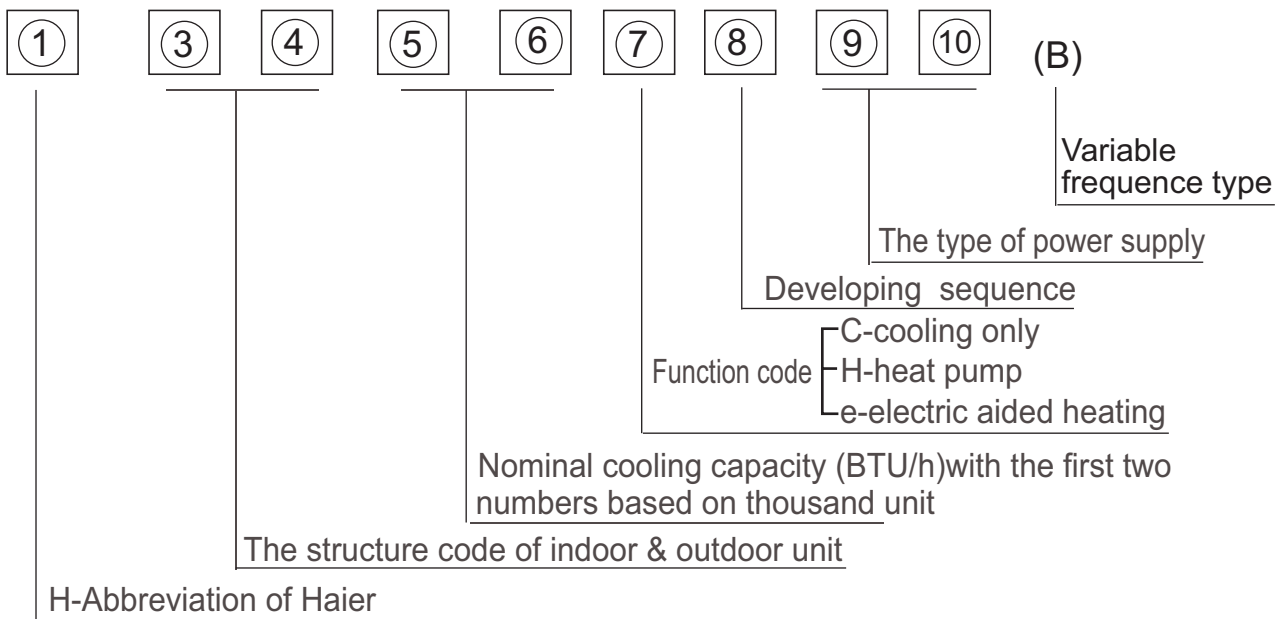

Examples:

HSU-12RA03, It represents wall-mounted split type room air conditioner. The cooling capacity is 12000BTU/h, and the power supply is 220-230V/50Hz.

Standard Situation/Conditions

No.	Operating condition	indoor air status		outdoor air status	
		DB°C	WB°C	DB°C	WB°C
1	Norminal cooling	27°C	19°C	35°C	24°C
2	Norminal heating	20°C	Not control	7°C	6°C
3	Norminal electrical heating	---	---	---	---

C.Series brief introduction

1.comfortable:wide-angle airflow

The vertical dual-flap and horizontal wide-angle louvers ensure the cool(warm) air reaches every corner of the room.

2.Health air purifying

An air purifying filter with deodorizing and disinfecting functions keeps the air clean and users healthy.

3.Quiet operation

Fan With Random-pitched Blades.

Random-pitched blades help reduce operating noise while maintaining a high airflow rate.

4.Energy efficient

The design of inner-grooved copper tube greatly increases the refrigerant contact area and the efficiency of cooling/heating functions.

5.Convenience

Auto restart and washable panel:

The grille can be removed easily and washed when necessary.Any series have the function then even if the power falls when the unit is operating unit will automatically return to the operating settings in use before the power failure when power is restored.

6.Wide variety of functions

24-Hour Timer:

24-hour timer allows users to select the exact time they would like the air conditioner to turn on and to turn off.Timers on previous models operation based on the number of hours of desired operation.

7.Night-set models

When the air conditioner is operating on the timer-off circuit.The preset room temperature gradually rises(going down in heating)before the unit stops as shown delow.Users can sleep comfortably without sudden change in temperature.

8.Program"dry"

This function automatically reduces the level of humidity while maintaining the preset indoor temperature.

Model:	HSU-09RA03	Appearance color (indoor/outdoor):	White/White
Cooling capacity:	2600W	Heating capacity:	3000W
Cooling coefficient:	2.82	Heating coefficient:	3.15
Cooling power input:	920W	Heating power input:	950W
Moisture removal	1.3X10-3m ³ /h	Frequency range	10~106 Hz
Operating voltage range	1PH, 220-230V~,50Hz	Refrigerant type	R22
Operating temp. range	-7°C-43°C	Air sending angle/distance	60°
Variation of temp. adjust	±1°C	Fan type/quantity	Cross flow fan(indoor unit) Axial fan(outdoor unit)
Climate type:	T1	Class of electric shock protection:	I
Indoor unit noise (cooling)	37/34/30dB(A)	outdoor unit noise (cooling)	48dB(A)
Indoor unit noise (heating)	38/35/31dB(A)	outdoor unit noise (heating)	49dB(A)
net dimensions	727*285*195 mm	net dimensions	700*430*250mm
Packaging dimensions (indoor unit)	770 x263x343mm	Packaging dimensions (outdoor unit)	888x328x599mm
weight(indoor unit)	8/10(net/gross)kg	Piling layers for indoor/outdoor unit	8/4
Max. mounting height difference:	5m	Outdoor unit net/gross weights:	34/37(net/gross) kg
Refrigerant charge	R22 820g	Current entering side (indoor/outdoor)	indoor
Frequency of filter cleaning	Once/2 weeks	Max. refrigerant charge	-----
Compressor model	2P18S225ANC	Compressor manufacturer	Panasonic
Compressor oil charge	405ml	Compressor protector type	INTERNAL
Maxi. length of connecting pipe:	7m	model of 4-way valve:	-----
Cap. tube type muffle model:	TP ₂ Y copper tube	Length/diameter of drain hose	2000mm/∅16mm
Fan speed: (r/min)	1250/1100/950 (indoor) 710 (outdoor)	Type/size of evaporator and condenser	Internal treaded pipe ∅7/∅9.52mm
Max. operating pressure at warm side:	2.65MPa	Max. operating pressure at cool side:	2.65MPa
cut-off valve:	1/4", 3/8"	Appearance features	Indoor unit: Plastic Outdoor unit: Sheet Metal

Model:	HSU-12RA03	Appearance color (indoor/outdoor):	White/White
Cooling capacity:	3600W	Heating capacity:	4100(700-5000)W
Cooling coefficient:	2.81	Heating coefficient:	3.10
Cooling power input:	1280W	Heating power input:	1320W
Moisture removal	1.7X10 ⁻³ m ³ /h	Frequency range	10~106 Hz
Operating voltage range	1PH, 220-230V~,50Hz	Refrigerant type	R22
Operating temp. range	-7°C-43°C	Air sending angle/distance	60°
Variation of temp. adjust	±1°C	Fan type/quantity	Cross flow fan(indoor unit) Axial fan(outdoor unit)
Climate type:	T1	Class of electric shock protection:	I
Indoor unit noise (cooling)	38/35/30dB(A)	outdoor unit noise (cooling)	49dB(A)
Indoor unit noise (heating)	40/36/33dB(A)	outdoor unit noise (heating)	50dB(A)
net dimensions	727*285*195 mm	net dimensions	780*540*245mm
Packaging dimensions (indoor unit)	858 x263x343mm	Packaging dimensions (outdoor unit)	888x328x599mm
weight(indoor unit)	10/12(net/gross)kg	Piling layers for indoor/outdoor unit	8/4
Max. mounting height difference:	5m	Outdoor unit net/gross weights:	39/45(net/gross) kg
Refrigerant charge	R22 1190g	Current entering side (indoor/outdoor)	indoor
Frequency of filter cleaning	Once/2 weeks	Max. refrigerant charge	-----
Compressor model	C-RVZ42H11AA	Compressor manufacturer	SANYO
Compressor oil charge	405ml	Compressor protector type	INTERNAL
Maxi. length of connecting pipe:	15m	model of 4-way valve:	-----
Cap. tube type muffle model:	TP ₂ Y copper tube	Length/diameter of drain hose	2000mm/∅16mm
Fan speed: (r/min)	1350/1175/1000 (indoor) 820/500 (outdoor)	Type/size of evaporator and condenser	Internal treaded pipe ∅7/∅9.52mm
Max. operating pressure at warm side:	2.65MPa	Max. operating pressure at cool side:	2.65MPa
cut-off valve:	1/4", 1/2"	Appearance features	Indoor unit:Plastic Outdoor unit: Sheet Metal

Curves of performance of compressor

% Compressor curves of performance

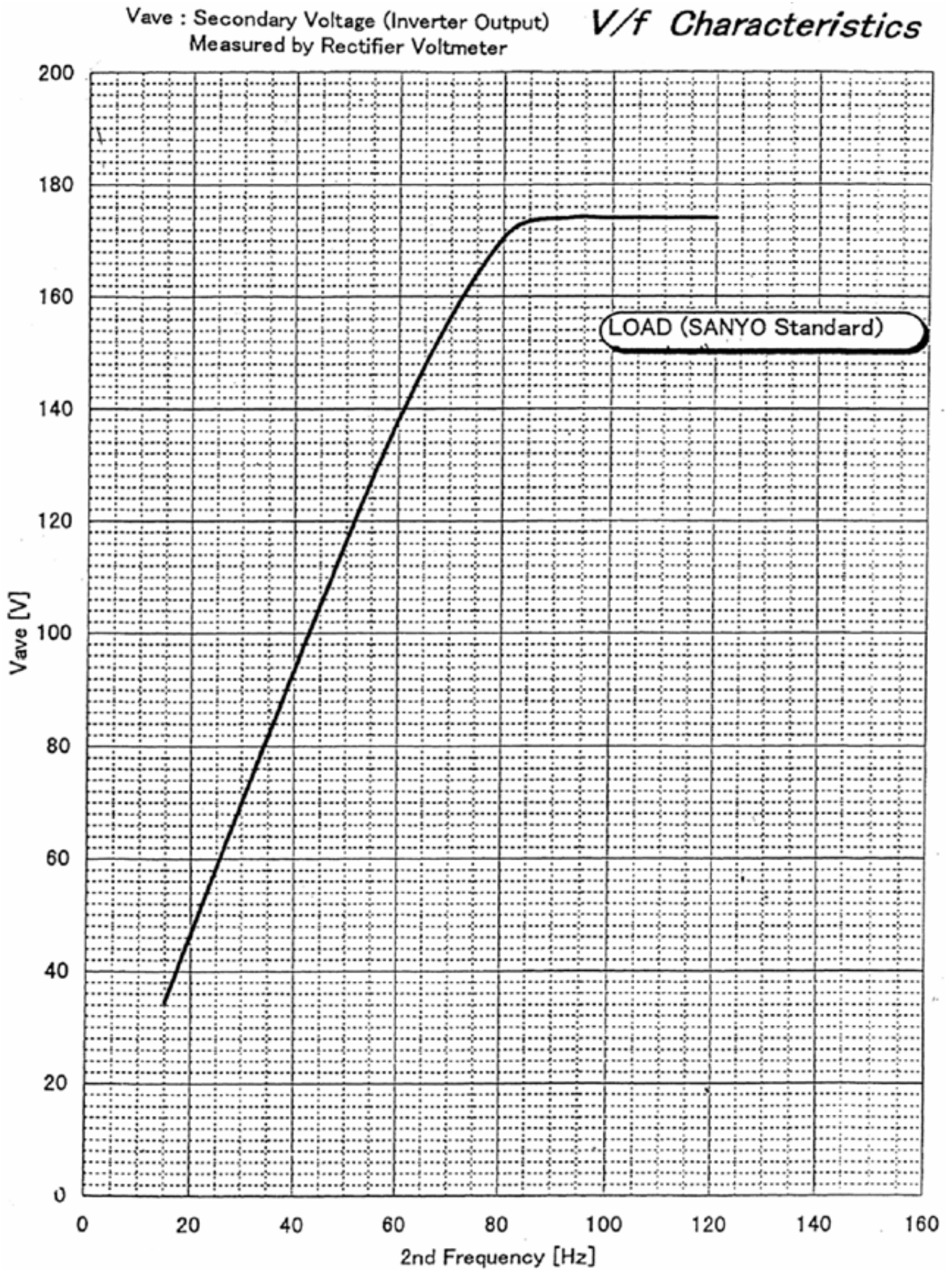

B. curves of performance

Adjust temperature range: -7°C ~ 43°C

Cooling

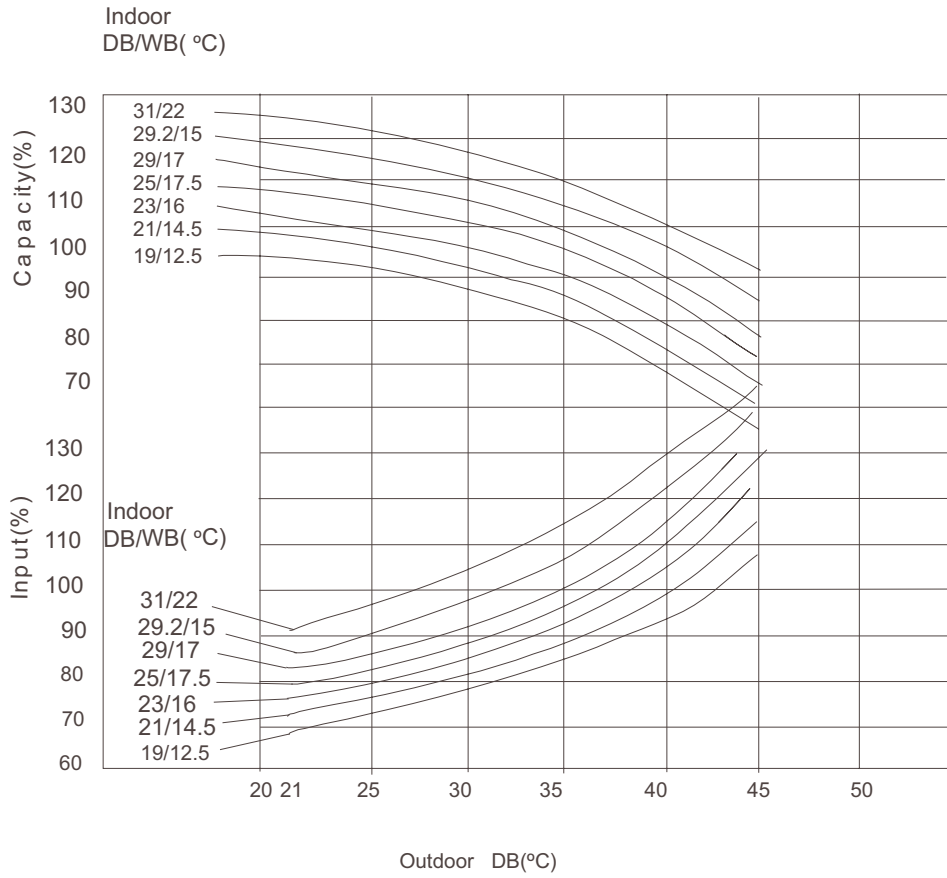

Heating

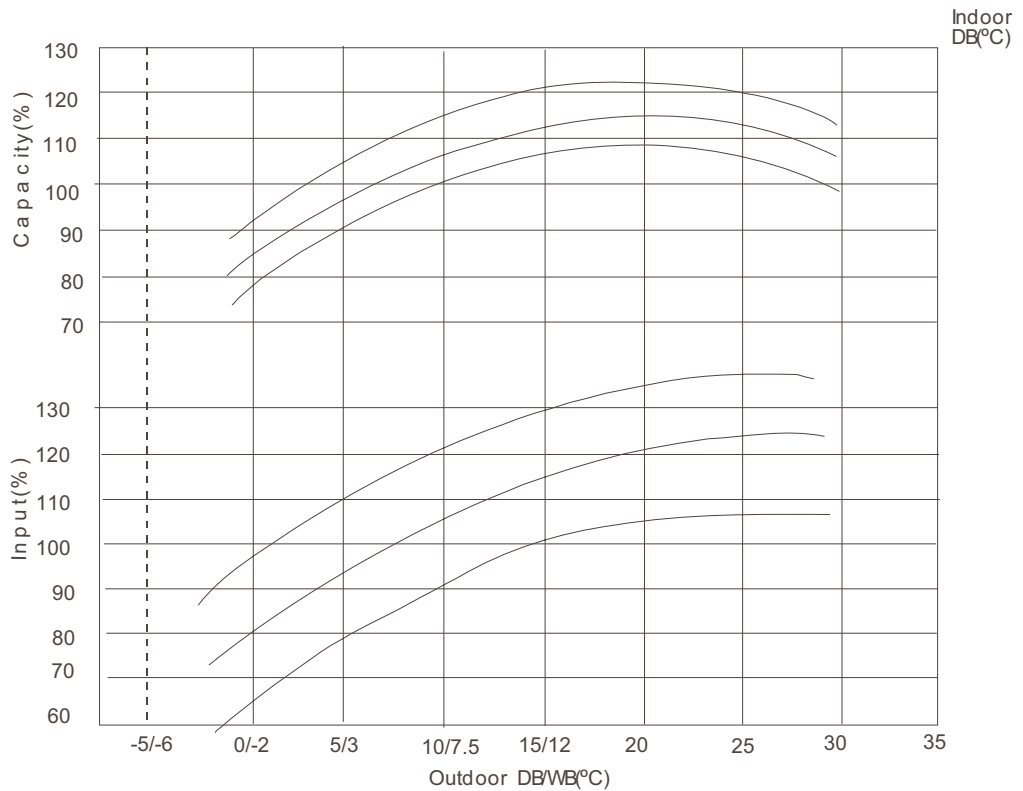

Curves of compressor performance

Compressor:C-RV242H11AA

Model:HSU-12RA03

C-RV242H11AA
1PH,50Hz,220V
35uF/400VCA
R22

	A	B	C	D	E
Condensing temp °C	40.5	45	50	54.4	60
Rerurn gas temp °C	35	35	35	35	35
Super-cooling temp °C	32.2	36.7	41.7	46.1	51.7
Ambient temp °C	35	35	35	35	35

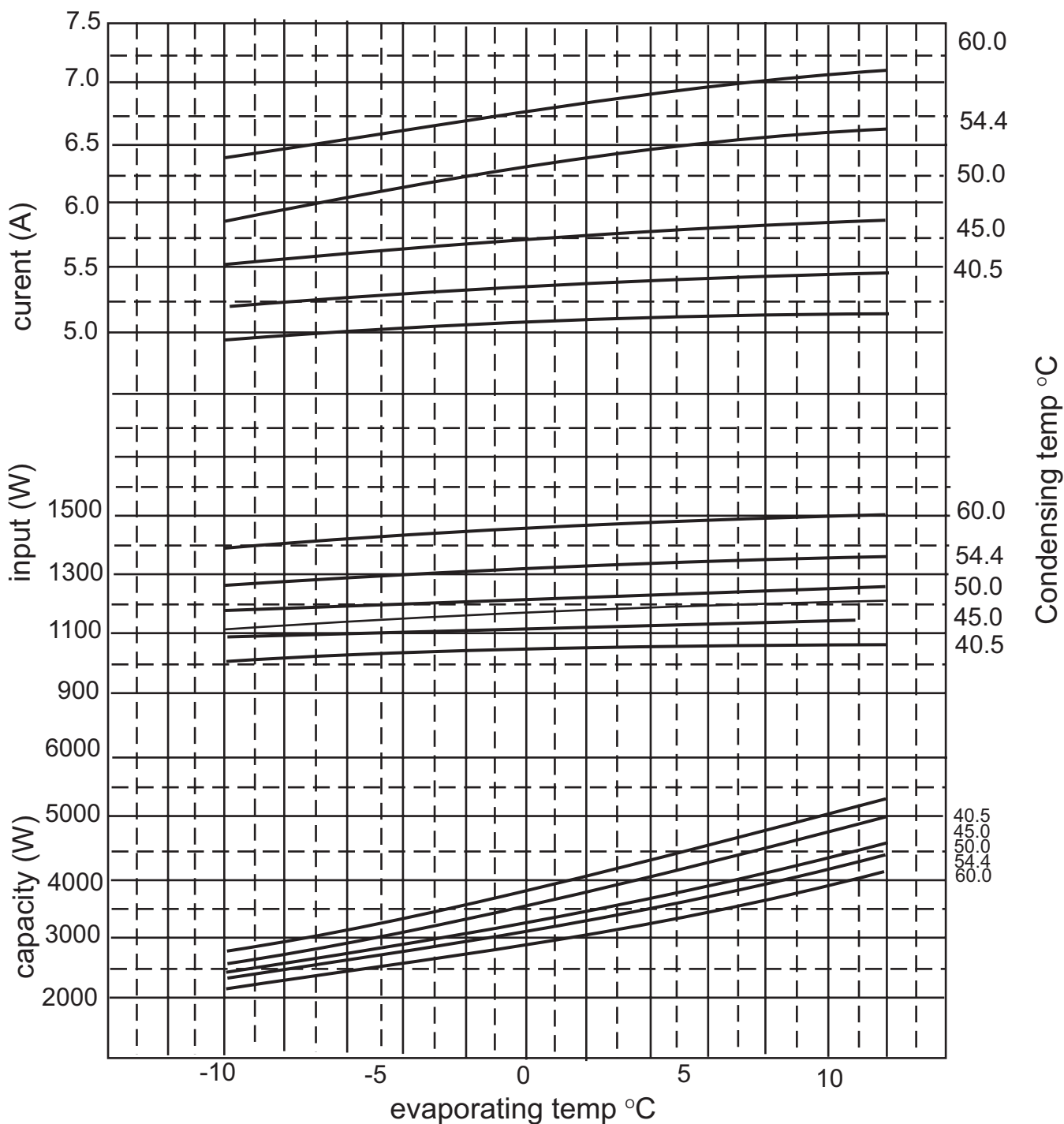

Description, dimension and function of main components and accessories

Indoor unit

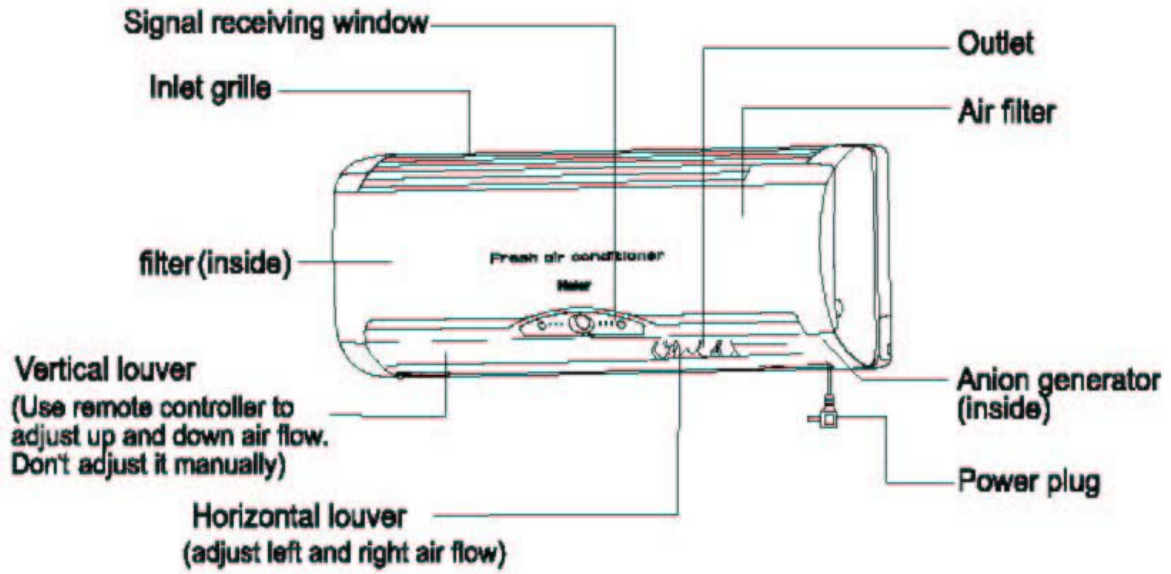

Control panel

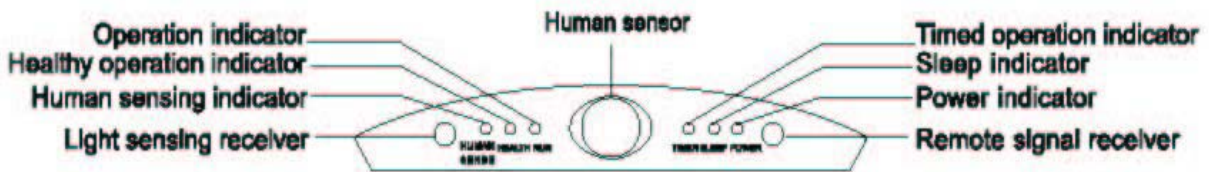

Outdoor unit

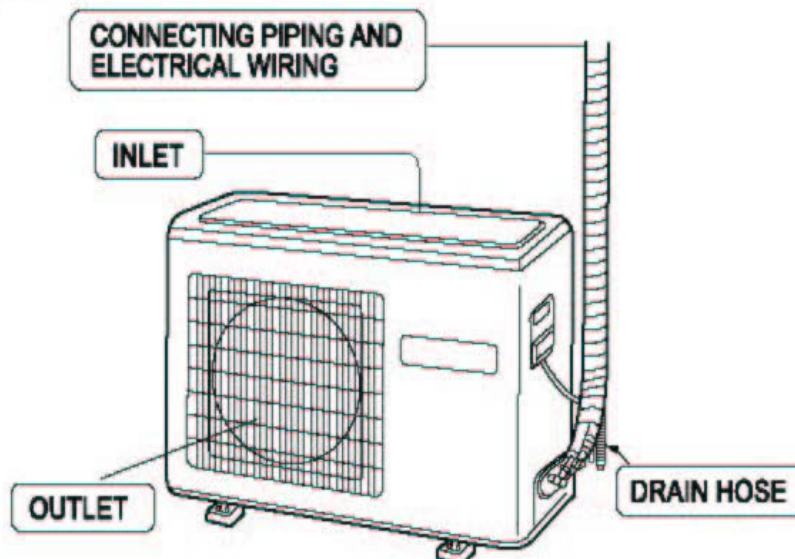

NET DIMENSIONS FOR INDOOR UNITS:

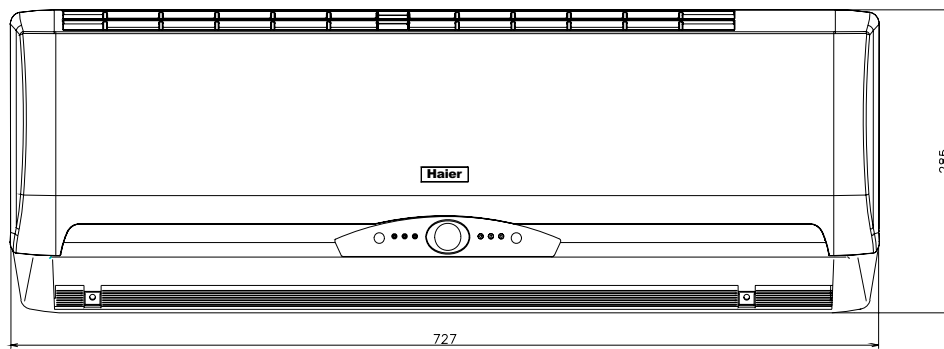

NET DIMENSIONS FOR OUTDOOR UNITS:

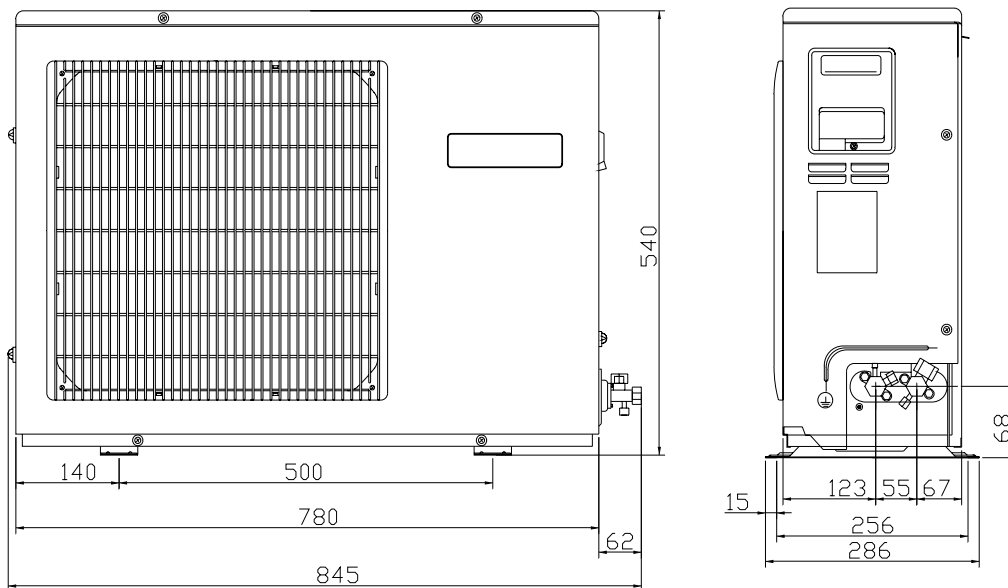

Description, dimension and function of main components and accessories

Parts and functions

- Do not obstruct or cover the ventilation grille of the air conditioner. Do not put fingers or any other things into the inlet/outlet and swing louver.
- Do not allow children to play with the air conditioner. In no case should children be allowed to sit on the outdoor unit.

Specifications

- The refrigerating circuit is leak-proof.

The machine is adaptive in following situation

1. Applicable ambient temperature range:

Cooling	Indoor	Maximum: D.B/W.B 32°C / 23°C Minimum: D.B/W.B 18°C / 14°C
	Outdoor	Maximum: D.B/W.B 43°C / 26°C Minimum: D.B 18°C
Heating	Indoor	Maximum: D.B 27°C Minimum: D.B 15°C
	Outdoor	Maximum: D.B/W.B 24°C / 18°C Minimum: D.B/W.B -7°C / -8°C

2. If the power supply cord is damaged, it must be replaced by the manufacturer or its service agent or a similar qualified person.
3. If the fuse of indoor unit on PC board is broken, please change it with the type of T. 3.15A/ 250V.
4. The wiring method should be in line with the local wiring standard.
5. After installation, the power plug should be easily reached.
6. The waste battery should be disposed properly.

7. The appliance is not intended for use by young children or infirm persons without supervision.
8. Young children should be supervised to ensure that they do not play with the appliance.
10. Please employ the proper power plug, which fit into the power supply cord.
11. The power plug and connecting cable must have acquired the local attestation.

Knock-down drawings and part lists

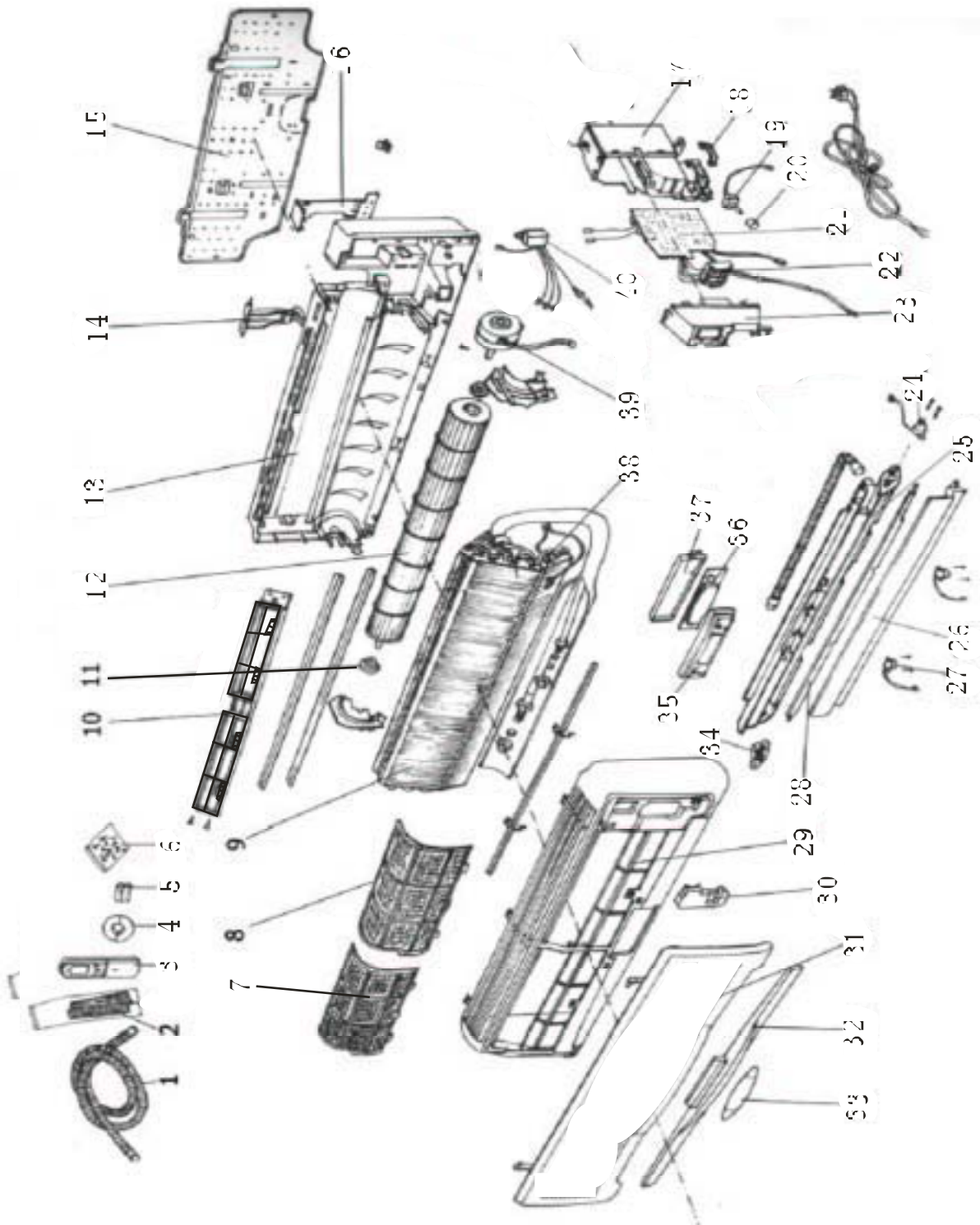

Knock-down draws and parts

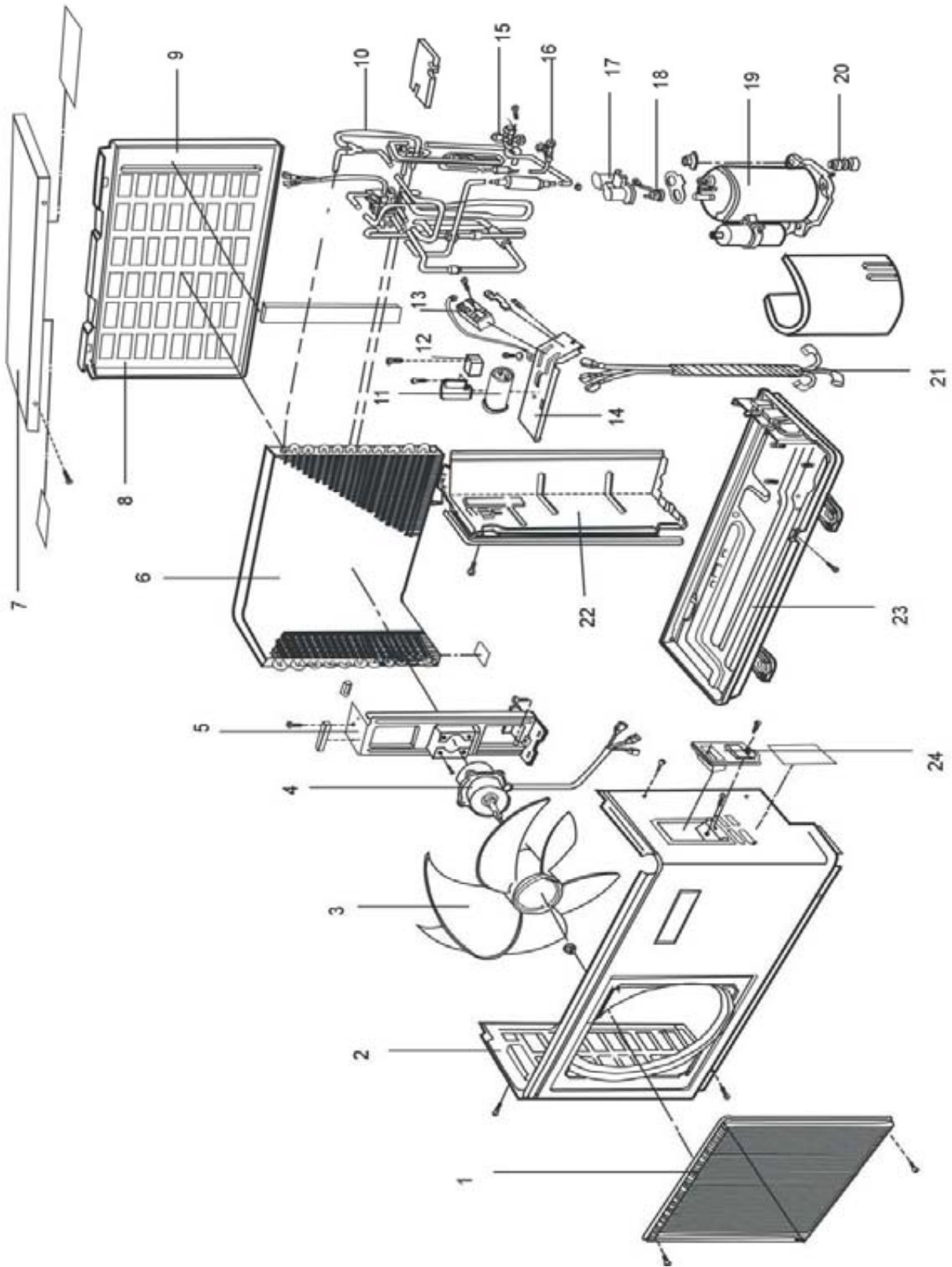

No. in exploded view	Spare parts number	Spare parts description in english	Model	Qty	Price list(USA)	Failure rate	The proportion of the spare part stock	Remark
1	001A1434039	Drain tube	HSU-09RA03			0.1	0.15	
2	0010804877	Air purifying	HSU-09RA03	2		0.1	0.15	
3	-----	Remote controller	HSU-09RA03	1		0.1	0.15	
4	001A1433307	Guard ring	HSU-09RA03	1		0.1	0.15	
5	001A4600001	Battery	HSU-09RA03	2		0.1	0.15	
6	0010600115	Bolt assy.	HSU-09RA03	1		0.1	0.15	
7	-----	Air filter	HSU-09RA03	1		0.1	0.15	
8	-----	Air filter	HSU-09RA03	1		0.1	0.15	
9	0010705885	Evaporator	HSU-09RA03	1		0	0	X
10	0010201065	Dust-gathered bracket	HSU-09RA03	1		0.1	0.15	
11	001A0300029	Bearing	HSU-09RA03	1		0.1	0.15	
12	0010201320	Fan	HSU-09RA03	1		0.2	0.25	*
13	0010801215	Rear case assy.	HSU-09RA03	1		0	0	X
14	001A1431767	Piping support	HSU-09RA03	1		0	0	X
15	0010101276	Mounting plate	HSU-09RA03	1		0	0	X
16	0010202537	Pipe shield board	HSU-09RA03	1		0	0	X
17	0010202248	Electrical box	HSU-09RA03	1		0.1	0.15	
18	001A1431899	Line press board	HSU-09RA03	1		0.1	0.15	
19	-----	Power switch	HSU-09RA03	1	-----	-----		
20	-----	Switch nip	HSU-09RA03	1	-----	-----		
21	0010402759	PCB	HSU-09RA03	1		0.2	0.25	X
22	0010401858	Terminal block	HSU-09RA03	1		0.2	0.25	
23	0010201304	Electrical box cover	HSU-09RA03	1		0	0	X
24	0010400937	Swing motor	HSU-09RA03	2		0.2	0.25	*
25	0010802211	Drain pan assy.	HSU-09RA03	1		0.1	0.15	
26	0010201639	Big flap	HSU-09RA03	1		0.1	0.15	
27	0010400937	Swing motor	HSU-09RA03	2		0.2	0.25	*
28	0010201640	Small flap	HSU-09RA03	1		0.1	0.15	
29	0010200083	Front panel	HSU-09RA03	1		0	0	X
30	0010202506	Line shelve cover	HSU-09RA03	1		0.1	0.15	
31	-----	Front grille	HSU-09RA03	1		0.1	0.15	
32	-----	Decorate bar	HSU-09RA03	1		0.1	0.15	
33	0010802060	Decorate board	HSU-09RA03	1		0.1	0.15	
34	-----	Gear assy.	HSU-09RA03	1	-----	-----		
35	0010202250	Top LED box	HSU-09RA03	1		0.1	0.15	
36	0010402171	PCB board	HSU-09RA03	1		0.2	0.25	*
37	001A14311263	Bottom LED box	HSU-09RA03	1		0.1	0.15	
38	001A3900059	Sensor	HSU-09RA03	1		0.2	0.25	*
39	001A3000049	Motor	HSU-09RA03	1		0.2	0.25	*
40	0010400337	Negative ion generator	HSU-09RA03	1		0.2	0.25	*

1,The failer rate and the proportion of the spare-part stock are regarded as the reference of the stock for spare-parts;The first time should be stocked accorded with the proportion of the spare-parts,and it should be adjusted with the actual quantity 3 months later.

2,easy-damaged;The spare-part which is often damaged and the customer must stock in the spare-parts warehouse,and should be marked with""

3,possible damaged:The spare-part which is not often damaged like the easy damaged one and the customer may stock in the spare-part warehouse accord with the actual case,should be marked with " " .

4,not need provided :The spare-part which is seldom damaged or the maintenance man could not maitmains.The spare parts may be air freighted by the factory if they were damaged.The customer nees not stock in the spare-part warehouse,should be marked with " x " .

5,Above should be improved accord with the reply of the market half a year per time.

6.The spare parts price on net is FOB Qingdao term.



o i r o n d i o n r o d outdoor

Edition:2005/06/18

No. in exploded view	Spare parts number	Spare parts description in english	Model	Qty	Price list(\$)	Failure rate	The proportion of the spare part stock	Remark
1	001A1436043A	Front grille	HSU-09RA03	1		0.1	0.15	
2	0010101051	Front panel	HSU-09RA03	1		0	0	X
3	001A2331030A	Fan	HSU-09RA03	1		0.2	0.25	*
4	001A3000074	Motor	HSU-09RA03	1		0.2	0.25	*
5	0010100419	Bracket	HSU-09RA03	1		0	0	X
6	0010703323	Heat exchanger	HSU-09RA03	1		0	0	X
7	001A0100018A	Top panel	HSU-09RA03	1		0	0	X
8	001A1101011	Back grille	HSU-09RA03	1		0.1	0.15	
9	001A2500011	4-way valve coil	HSU-09RA03	1		0.2	0.25	*
10	001B0500021	pipe assy	HSU-09RA03	1		0	0	X
11	001A3600032	Capacitor for comp.	HSU-09RA03	1		0.2	0.25	*
12	001A3600009B	Capacitor for motor	HSU-09RA03	1		0.2	0.25	*
13	001A4000092	Terminal block	HSU-09RA03	1		0.2	0.25	*
14	0010802214	Electric box	HSU-09RA03	1		0.1	0.15	
15	0010702406	Stop valve	HSU-09RA03	1		0.1	0.15	
16	0010702409	Stop valve	HSU-09RA03	1		0.1	0.15	
17	-----	wires cover	HSU-09RA03	1			0	X
18	-----	Protector	HSU-09RA03	1			0	X
19	0010700520	compressor	HSU-09RA03	1		0.1	0.15	
20	-----	cushion	HSU-09RA03	1			0	X
21	001A4400389	wires	HSU-09RA03	1		0.1	0.15	
22	0010801958	Separating plate	HSU-09RA03	1		0	0	X
23	0010801560	Bottom plate assy	HSU-09RA03	1		0	0	X
24	001A4000092	Terminal block	HSU-09RA03	1		0	0	*
25	0010802027	Oxygen-created box	HSU-09RA03	1		0	0	X

1,The failer rate and the proportion of the spare-part stock are regarded as the reference of the stock for spare-parts;The first time should be stocked accroded with the proportion of the spare-parts,and it should be adjusted with the actual quantity 3 months later.

2,easy-damaged;The spare-part which is often damaged and the customer must stock in the spare-parts warehouse,and should be marked with"*"

3,possible damaged:The spare-part which is not often damaged like the easy damaged one and the customer may stock in the spare-part warehouse accord with the actual case,should be marked with " " .

4,not need provided :The spare-part which is seldom damaged or the maintenance man could not maitmains.The spare parts may be air freighted by the factory if they were damaged.The customer nees not stock in the spare-part warehouse,should be marked with " x " .

5,Above should be improved accord with the reply of the market half a year per time.

6.The spare parts price on net is FOB Qingdao term.

No. in exploded view	Spare parts number	Spare parts description in english	Model	Qty	Price list(USA)	Failure rate	The proportion of the spare part stock	Remark
1	001A1434039	Drain tube	HSU-12RA03			0.1	0.15	
2	0010804877	Air purifying	HSU-12RA03	2		0.1	0.15	
3	-----	Remote controller	HSU-12RA03	1		0.1	0.15	
4	001A1433307	Guard ring	HSU-12RA03	1		0.1	0.15	
5	001A4600001	Battery	HSU-12RA03	2		0.1	0.15	
6	0010600115	Bolt assy.	HSU-12RA03	1		0.1	0.15	
7	001A2400150	Air filter	HSU-12RA03	1		0.1	0.15	
8	001A2400150	Air filter	HSU-12RA03	1		0.1	0.15	
9	0010705886	Evaporator	HSU-12RA03	1		0	0	X
10	0010200917	Dust-gathered bracket	HSU-12RA03	1		0.1	0.15	
11	001A0300029	Bearing	HSU-12RA03	1		0.1	0.15	
12	001A0300028	Fan	HSU-12RA03	1		0.2	0.25	*
13	0010802170	Rear case assy.	HSU-12RA03	1		0	0	X
14	001A1431767	Piping support	HSU-12RA03	1		0	0	X
15	0010101276	Mounting plate	HSU-12RA03	1		0	0	X
16	0010202537	Pipe shield board	HSU-12RA03	1		0	0	X
17	0010202248	Electrical box	HSU-12RA03	1		0.1	0.15	
18	001A1431899	Line press board	HSU-12RA03	1		0.1	0.15	
19	-----	Power switch	HSU-12RA03	1	-----	-----		
20	-----	Switch nip	HSU-12RA03	1	-----	-----		
21	0010402759	PCB	HSU-12RA03	1		0.2	0.25	X
22	0010401858	Terminal block	HSU-12RA03	1		0.2	0.25	
23	0010201304	Electrical box cover	HSU-12RA03	1		0	0	X
24	0010400937	Swing motor	HSU-12RA03	2		0.2	0.25	*
25	0010801490	Drain pan assy.	HSU-12RA03	1		0.1	0.15	
26	0010201639	Big flap	HSU-12RA03	1		0.1	0.15	
27	0010400937	Swing motor	HSU-12RA03	2		0.2	0.25	*
28	0010201640	Small flap	HSU-12RA03	1		0.1	0.15	
29	001A14311255	Front panel	HSU-12RA03	1		0	0	X
30	001A14311295	Line shelve cover	HSU-12RA03	1		0.1	0.15	
31	-----	Front grille	HSU-12RA03	1		0.1	0.15	
32	-----	Decorate bar	HSU-12RA03	1		0.1	0.15	
33	0010802060	Decorate board	HSU-12RA03	1		0.1	0.15	
34	-----	Gear assy.	HSU-12RA03	1	-----	-----		
35	0010202250	Top LED box	HSU-12RA03	1		0.1	0.15	
36	0010402171	PCB board	HSU-12RA03	1		0.2	0.25	*
37	001A14311263	Bottom LED box	HSU-12RA03	1		0.1	0.15	
38	001A3900059	Sensor	HSU-12RA03	1		0.2	0.25	*
39	001A3000049	Motor	HSU-12RA03	1		0.2	0.25	*
40	0010400337	Negative ion generator	HSU-12RA03	1		0.2	0.25	*

1,The failer rate and the proportion of the spare-part stock are regarded as the reference of the stock for spare-parts;The first time should be stocked accroded with the proportion of the spare-parts,and it should be adjusted with the actual quantity 3 months later.

2,easy-damaged;The spare-part which is often damaged and the customer must stock in the spare-parts warehouse,and should be marked with"***"

3,possible damaged:The spare-part which is not often damaged like the easy damaged one and the customer may stock in the spare-part warehouse accord with the actual case,should be marked with " " .

4,not need provided :The spare-part which is seldom damaged or the maintenance man could not maitmains.The spare parts may be air freighted by the factory if they were damaged.The customer needs not stock in the spare-part warehouse,should be marked with " x " .

5,Above should be improved accord with the reply of the market half a year per time.

6.The spare parts price on net is FOB Qingdao term.

No. in exploded view	Spare parts number	Spare parts description in english	Model	Qty	Price list(\$)	Failure rate	The proportion of the spare part stock	Remark
1	001A1436043A	Front grille	HSU-12RA03	1		0.1	0.15	
2	0010101051	Front panel	HSU-12RA03	1		0	0	X
3	001A2331030A	Fan	HSU-12RA03	1		0.2	0.25	*
4	001A3000075	Motor	HSU-12RA03	1		0.2	0.25	*
5	0010100418	Bracket	HSU-12RA03	1		0	0	X
6	0010702671	Heat exchanger	HSU-12RA03	1		0	0	X
7	001A0100018	Top panel	HSU-12RA03	1		0	0	X
8	001A1101013	Back grille	HSU-12RA03	1		0.1	0.15	
9	001A2500015	4-way valve coil	HSU-12RA03	1		0.2	0.25	*
10	001B0500031	pipe assy	HSU-12RA03	1		0	0	X
11	001A3600021	Capacitor for comp.	HSU-12RA03	1		0.2	0.25	*
12	001A3600009B	Capacitor for motor	HSU-12RA03	1		0.2	0.25	*
13	001A4000092	Terminal block	HSU-12RA03	1		0.2	0.25	*
14	0010802100	Electric box	HSU-12RA03	1		0.1	0.15	
15	0010702408	Stop valve	HSU-12RA03	1		0.1	0.15	
16	0010702407	Stop valve	HSU-12RA03	1		0.1	0.15	
17	-----	wires cover	HSU-12RA03	1			0	X
18	-----	Protector	HSU-12RA03	1			0	X
19	0010702646	compressor	HSU-12RA03	1		0.1	0.15	
20	-----	cushion	HSU-12RA03	1			0	X
21	001A4400389	wires	HSU-12RA03	1		0.1	0.15	
22	0010801988	Separating plate	HSU-12RA03	1		0	0	X
23	001A0100029	Bottom plate assy	HSU-12RA03	1		0	0	X
24	001A4000092	Terminal block	HSU-12RA03	1		0	0	*
25	0010802027	Oxygen-created box	HSU-12RA03	1		0	0	X

1,The failer rate and the proportion of the spare-part stock are regarded as the reference of the stock for spare-parts;The first time should be stocked accroded with the proportion of the spare-parts,and it should be adjusted with the actual quantity 3 months later.

2,easy-damaged;The spare-part which is often damaged and the customer must stock in the spare-parts warehouse,and should be marked with"*"

3,possible damaged:The spare-part which is not often damaged like the easy damaged one and the customer may stock in the spare-part warehouse accord with the actual case,should be marked with " " .

4,not need provided :The spare-part which is seldom damaged or the maintenance man could not maitmains.The spare parts may be air freighted by the factory if they were damaged.The customer nees not stock in the spare-part warehouse,should be marked with " x " .

5,Above should be improved accord with the reply of the market half a year per time.

6.The spare parts price on net is FOB Qingdao term.

Brief introduction to electrical control functions

1. Automatic mode:
cold/warm type run mode:

After entering into this mode, the main control “MCU” determines the corresponding work pattern according to the indoor temperature so as to maintain the preset temperature (the temperature is 23°C in heating mode, and 26°C in cooling mode). When Starting the machine for the first time, the machine enter heating mode if the indoor temperature is or below 23°C or enter cooling mode if the indoor temperature is 23°C. After the unit enters heating mode and conducts heating programme (the preset temperature is 23°C), When reaching halt temperature of compressor, the compressor stops for 15 minutes. Then the machine enter cooling mode if the temperature of inlet air detected is or above 27°C, or the unit is still in heating mode. When the unit enters cooling mode conducts cooling programme (the preset temperature is 26°C), compensation temperature difference is cancelled automatically. When reaching halt temperature of compressor, the compressor stops for 15 minutes. Then the machine enter heating mode if the temperature of inlet air detected is or below 23°C and compensation temperature is added automatically, or the unit is still in cooling mode. When the machine is transferred to the automatic mode from other modes, it will stop for 3 minutes if operating mode is changed (judge first and then work), and then enter the judged temperature according to the temperature of indoor inlet air.

*This mode includes the functions of timing, sleeping and so on. The machine enter cooling sleep mode when entering heating mode and enter cooling sleep mode when entering cooling mode.

2. Cooling run mode:

*cooling indicator is on.(runing indicator is on For HSU-09RA03)

*temperature control range : 16°C —30°C

*temperature control precision: ±1°C

*compressor can't be controlled by temperature sensor within 2 minutes after it starts.

*control character: when T_r (inlet air) $\geq T_s$ (temperature setting), outlet air from compressor is on and indoor fan motor run at fixed wind speed. When T_r (inlet air) $< T_s$ (temperature setting), outlet air from compressor is off, and when $T_r > T_s$, outlet air from compressor is on.

*wind speed control: (the temperature difference is 1°C)

auto: when $T_r \geq T_s + 3^\circ\text{C}$, the wind speed is high;

when $T_s + 1^\circ\text{C} \leq T_r < T_s + 3^\circ\text{C}$, the wind speed is medium.

When $T_r < T_s + 1^\circ\text{C}$, the wind speed is low.

When temperature sensor is off, the fan motor runs at low speed.

when the wind speed changes from low to high, there is no delay, and when it changes from high to low, there is a 3-minutes delay before conversion.

Manual operation: When unit is on the wind speed can be set to high, medium, low or automatic as required (execute instruction 2 seconds later after receiving remote signal)

*compressor control: The compressor can't be controlled by temperature sensor within 2 minutes after startup and can be only restarted at least 3 minutes later after shutdown. There is no 3-minute protection with power on for the first time (over 3 minutes with power off). The compressor must stand by for 3 minutes before it is restarted after shutdown.

*There is no 2-minute limit when changing the temperature setting or shutting down the machine through the remote controller, and the machine can be shut down immediately.

- * Avoiding electrical shock: outlet air is available 2 seconds later after startup.
- *Controlling the position of air door: set the position of air door as required.
- *Protection of temperature expiration is available: The compressor and outdoor fan motor will be shut down when the indoor temperature is above 72°C and lasts 2 seconds. Only when 3 minutes pass by after shutdown and the temperature of coil pipe is below 64°C, can the compressor be started, while indoor fan motor is controlled as the temperature sensor is off.
- *Protection of expiration of current peak value is available: Current cross detection is available in order to avoid burning out the compressor when the current is too big. The action character as follows:
The compressor can't be detected in 60 seconds after startup. when current is above "CT 1.6 V" and lasts 3 seconds, the system enter protection mode and shut off compressor with outdoor air blower and indoor fan motor controlled as the temperature sensor is off. After 3 minutes the machine can be started again.
- *Protection of frost is available (disable in test run or heating mode): In order to prevent the indoor heat exchanger from freezing (in refrigeration or dehumidifying mode), the compressor will be shut off when the temperature of the indoor coil pipe is or below 0°C and the compressor runs for over 5 minutes. When the temperature of the indoor coil pipe ascends to over 7°C, the compressor is restarted (must meet a 3-minutes delay)
- *Timer on, Timer off and sleep control are available.

3. Dry mode: (the temperature difference is 1°C)

- *dry indicator is on.(runing indicator is on For HSU-09RA03)
- *Temperature control range : 16°C —30°C
- *Temperature control precision: ±1°C
- *control character:
 - When T_r (indoor temperature) > T_s (temperature setting) +2°C, compressor and outdoor fan motor run continuously with indoor fan motor running in accordance with the wind speed setting.
 - When T_r ranges from T_s to T_s +2°C, outlet air from compressor is on for 10 minutes and off for 6 minutes, the indoor fan motor is off in 3 minutes after shutdown of compressor and gives breeze in other time.
 - When $T_r < T_s$, outlet air from compressor is unavailable, and the indoor fan motor enter breeze mode 3 minutes later after after shut down of compressor.
 - When all the ranges alternate, there is ±1°C difference.
- *Fan speed control:
 - Automation: When $T_i \geq T_s + 5^\circ\text{C}$, the fan speed is high.
 - When $T_s + 3^\circ\text{C} \leq T_i < T_s + 5^\circ\text{C}$, the fan speed is medium.
 - When $T_s + 2^\circ\text{C} \leq T_i < T_s + 3^\circ\text{C}$, the fan speed is low.
 - When $T_s \leq T_i < T_s + 2^\circ\text{C}$, the machine gives breeze intermittently.
 - When $T_i < T_s$, there are 3 minutes to stand by before the indoor fan motor is shut off.
 - When $T_i < T_s$, there are 3 minutes to stand by before entering of breeze from

outside.

Manual operation: When the temperature sensor is off or the indoor fan motor runs intermittently, the indoor fan motor can not be operated by hand (compelling automatic operation), along with the indoor fan motor can be operated in cooling mode. While controlling fan motor by hand in cooling mode, the cooling ranges include fan speed setting and refrigeration range, others are the same as fan motor in automation mode.

- *compressor control: The compressor can't be controlled by temperature sensor in 2 minutes after startup and also can't be started again at least 3 minutes later after shutdown. There are 3-minutes protection with power on for the first time (over 3 minutes with power off). The compressor must be started again 3 minutes later after shutdown.
- *There is no 2-minutes limit when changing the temperature setting or shutting off the machine through the remote controller, and the machine can be shut down immediately.
- *Avoiding electrical shock: outlet air is available 2 seconds later after startup.
- *Controlling the position of air door: set the position of air door as required.
- *Protection of temperature expiration is available: The compressor and outdoor fan motor will be shut down when the indoor temperature is above 72°C and lasts 2 seconds. Only when 3 minutes pass by after shutdown and the temperature of coil pipe is below 64°C, can the compressor be started, while indoor fan motor is controlled as the temperature sensor is off.
- *Protection of expiration of current peak value is available: Current cross detection is available in order to avoid burning out the compressor when the current is too big. The action character as follows:

follows:

The compressor can't be detected in 60 seconds after startup. when current is above "CT 1.6 V" and lasts 3 seconds, the system enter protection mode and shut off compressor with outdoor fan motor and indoor fan motor controlled as the temperature sensor is off. After 3 minutes the machine can be started again.

- *Protection of frost is available (disable in test run or heating mode): In order to prevent the indoor heat exchanger from freezing (in refrigeration or dehumidifying mode), the compressor will be shut off when the temperature of the indoor coil pipe is or below 0°C and the compressor runs for over 5 minutes. When the temperature of the indoor coil pipe ascends to over 7°C, the compressor is restarted (must meet a 3-minutes delay)
- *Timer on, Timer off and sleep control are available.

4. Heating mode: (the return difference of control is $\pm 1^\circ\text{C}$)

- *Heating indicator is on (runing indicator is on For HSU-09RA03)
- *Temperature control range : 16°C —30°C
- *Temperature control precision: $\pm 1^\circ\text{C}$
- *Control Character:

When $T_r \leq T_s$, compressor, four-way valve and outdoor fan motor is on, indoor fan motor runs as in cold blast mode, and 4°C of compensation is added after compressor is started.

When $T_r > T_s + 4^\circ\text{C}$, compressor is off, and the indoor fan motor runs as in cold blast mode.

When $T_r < T_s + 4^\circ\text{C}$, compressor, four-way valve and outdoor fan motor is on, and the indoor fan motor runs as in the mode of avoiding cold blast.

- *Control of indoor fan motor:

Manual operation: The fan speed can be set to high, medium, low or automatic as required.

Automatic operation: When $T_r < T_s$, the fan speed is high;
 When $T_s + 2 \geq T_r > T_s$, the fan speed is medium.
 When $T_r > T_s + 2$, the fan speed is low.

- *Control of air door: setting the position of air door as required.
- *compressor control: The compressor can't be controlled by temperature sensor in 8 minutes after startup and also can't be started again at least 3 minutes later after shutdown. There are 3-minute protection with power on for the first time (over 3 minutes with power off). The compressor must be started again 3 minutes later after shutdown.
- *There is no 8-minutes limit when changing the temperature setting or shutting off the machine through the remote controller, and the machine can be shut down immediately.
- *Avoiding electrical shock: outlet air is available 2 seconds later after startup.
- *Timer on, Timer off and sleep control are available.
- *Control of 4-way valve: When the unit is started for the first time, the 4-way valve starts running 10 seconds earlier than compressor does. After compressor stops running, the 4-way valve continues running for 2 minutes and then stops. If changing the unit from heating to cooling, the 4-way valve is shut off 2 minutes later and compressor is started 3 minutes later.
- *Cold draft prevention:
 - (1) Compressor is interrupted during the defrosting operation and continues to run after defrosting is completed. When the indoor exchanging temperature is below 23°C , the indoor fan motor is off. When the indoor exchanging temperature is above 23°C , the indoor fan motor is running at weak speed.
 - (2) If the temperature of coil pipe can't be above 38°C 4 minutes later after startup, fan motor is running at the preset wind speed.
 - (3) If the temperature of coil pipe is above 38°C 4 minutes later after start up, fan motor is running at the preset fan speed.
 - (4) If coil pipe descends to the temp. lower than 38°C from 38°C . fan motor is running at the preset wind speed.
 - (5) If the temperature sensor is off. Compressor stops running. If the temperature of coil pipe is above 23°C , fan motor enter breeze mode; and if the temperature of coil pipe is below 20°C , fan motor stops running.
 - (6) Shut down the unit and indoor fan motor stops running.
- *High temperature protection and high temperature expiration protection:
 - High temperature prevention: When the temp. of coil pipe is above 65°C , the outdoor fan motor stops. When the temp descends to 60°C , the outdoor fan motor is restarted and fan speed invertage frequency is more than 45 seconds.
 - High temperature expiration prevention: When the temp. of coil pipe is above 72°C , compressor and outlet air stop running 2 seconds later, and inlet air runs as the temp. sensor is off. When compressor stands by for 3 minute and the temp. of coil pipe is below 64°C , the unit can be started again.
- *Current protection and current expiration protection: (Not detecting within 60 seconds after startup)
 - Current protection: If current detected is above (CT0.6V) and lasts 10 seconds continuously, outlet air stops. If current detected is below (CT0.53V), outlet air is regained and fan speed invertage frequency is more than 45 seconds.
 - Current peak expiration protection: If current detected is above (CT1.6V), 3 seconds later the

system enter current cross protection, compressor and outdoor fan motor stop and start again 3 minutes later, and air inlet runs as the temperature sensor is off.

***Overcooling protection:**

One and half a minutes later after compressor starts, if the temperature of coil pipe is below -4°C , compressor and air outlet stop, and air inlet runs according to the temp. setting. Compressor can be restarted 3 minutes later.

***Defrosting:**

1.Entry conditions of defrosting:

The entry conditions of defrosting is classified into two types: intelligentized defrosting and sensor defrosting. Through selecting and judging, the models without outdoor sensor defrosts according to intelligentized defrosting, and others with ensor defrosts according to sensor defrosting.

intelligentized defrosting:

- A. Indoor unit enter overload protection and air outlet stops when air outlet has been restarted and runs over 10 minutes, and compressor runs over 45 minutes in total and over 20 minutes continuously, and the temp. of indoor coil pipe is below 42°C .
- B. Compressor runs 20 minutes continuously, and the temp. of indoor coil pipe decreases 1°C per 6 minutes and this operation repeats 3 times, and the temp. of coil pipe is below 42°C , and 5 minutes later after compressor is restarted.
- C. When compressor runs over 3 hours in total and over 20 minutes continuously and after the temp. of indoor coil pipe is below 42°C , the system enters defrosting mode.
- D. The difference between the temp. of indoor coil pipe and the indoot temp. is below 18°C and lasts 5 minutes, and

If meeting any one of the conditions above mentioned, the unit enter intelligentized defrosting mode.

sensor defrosting: In heating mode, When compressor runs over 45 minutes continuously, and detecting defrosting temp. is below -5°C and the temp. of coil pipe is lower than 38°C , the unit enters defrosting programe. After entering this mode, if detecting defrosting temp. is above 12°C or defrosting time is above 9 minutes, then quit defrosting mode.

2.Exit conditions of defrosting:

Defrosting time is higher than 12 minutes (compressor is on), or CT current is above (CT0.6V).

- During the defrosting, if current peak value is cut off, the unit quit the defrosting mode. But the protection of expiration of current peak value is unavailable with 60 seconds after compressor is started.
- During the defrosting, abnormality of temp. sensor isn't detected.
- After quitting the defrosting mode, the fan motor enter cooling prevention mode.

3.Defrosting oscillogram:

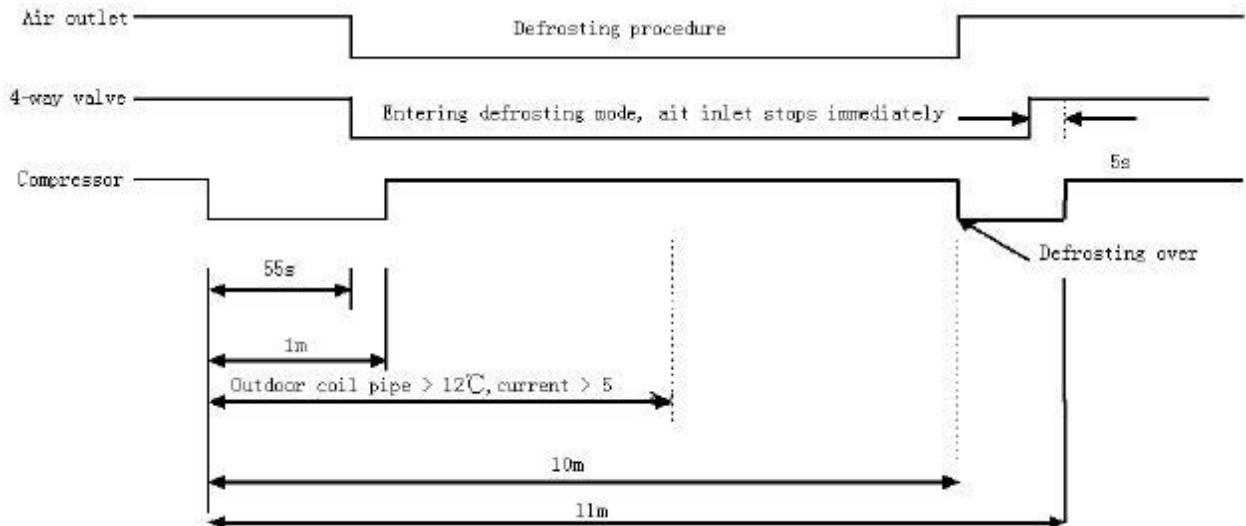

*Automatic temperature compensation of heating:

1. Conditions: Halt time of compressor is below 5 minutes.
2. Operation rules: 1) $T_s = T_r + 5^\circ\text{C} + (T_r - T_d \text{ (temperature detected)})[\text{the moment of startup}]$
2) $T_r - T_d[\text{the moment of startup}] \leq 2^\circ\text{C}$

Note: the two items above is disable when starting for the first time.

3) Press “-“ button in the remote controller, and then restore $T_s = T_r + 5^\circ\text{C}$.

Press “+” button in the remote controller, and then operate according to automatic compensation setting

4) If $T_r - T_d [\text{before compressor starts}] \leq 0^\circ\text{C}$, and then operate according to $T_s = T_r + 5^\circ\text{C}$.

3. If air door blow up, which is healthy, the temp. setting of heating is added by 2°C in the base of beginning.

5. Control function:

5.1 Timer function: You can set 24-hour timer on or timer off as required, and the minum time unit is 1 minute. After setting, the indicator of indoor unit is on , and it is off when timer setting is completed. There are several timer mode as follows.

- Timer on: The LED of “timer” lights up, and unit behaves with halt status. Timer on is completed, and then unit starts running with the LED of “timer” off. The unit starts with the last setting receiving timer signals, and sleep setting is not allowed.
- Timer off: Unit starts, timer indicator lights up; When reaching time setting, the indicator goes out, unit enters shutdown mode, and sleep function can be set. If timer off and sleep are set synchronously, the one which time is short run first. Executing shutdown instruction clear timer and sleep function.
- Timer on and timer off can be set synchronously. when they are completed, the indicator goes out.

5.2 Sleep function (saving function at night): the timer indicator lights up.

- In cooling/defrosting mode, the temp. setting increases 1°C one hour later after startup. After another hour the temp. setting increase by more 1°C and then run continuously for another 6 hours and then close.

- In heating mode, the temp. setting decrease 2℃ one hour after startup. After another hour the temp. setting decrease by more 2℃. After 3 hours the temp. setting rise by 1℃ and then run continuously for another 3 hours and then close.

5.3 Protection of malfunction of temperature sensitive resistance.

- The temperature sensitive resistor is short out or turn out, the machine doesn't work.
- During defrosting, don't detect if the temperature sensor short out or turn out.
- Detect the temperature of coil pipe is below -40℃, then think the temperation circuit of coil pipe is cut off.
- Detect the temperature of coil pipe is above 95℃, then think the temperation circuit of coil pipe is short .
- Detect the temperature of inlet air is below -20℃, then think the temperation circuit of coil pipe is cut off.
- Detect the temperature of inlet air is below -40℃, then think the temperation circuit of coil pipe is cut off.

5.4 Emergency switch input:

- Press the switch of emergency operation, then buzzer rings once and unit enters the automatic operation mode. (emergency operation)
- If the switch is kept pressed for 5 seconds, buzzer ring two times and unit enter enter test run mode.
- Press the switch again, and then closes.
- The unit can receive remote control.
- Enter emergency operation from timer mode, then timer is cancelled.
- Test run:
 - 1) The temperature sensor of inlet air doesn't work, and compressor starts (but subject to the limit of -minute delay excluding the first time), and high wind, cooling, and air door is open. The indoor fan motor runs, running indicator lights up, compressor relay and the one of outdoor fan motor is closed
 - 2) During test run:
 - The prevention of freezing of evaporator doesn't work.
 - Current cross control doesn't work.
 - The control of current cross peak expiration doesn't work.
 - Temperature control doesn't work.
 - Temperature expiration control doesn't work.

5.5 Executive function after 2 seconds by remoter control:

After receiving remote control signal, the mainboard doesn't enter the corresponding instruction task until 2 seconds elapse.

5.6 Increasing oxygen function:

There is increasing oxygen setting and gate switch is closed, the unit must run under conditions as follows. Or increasing oxygen function close.

- (1) Shutdown status: Increasing oxygen, outdoor fan motor, indoor fan motor is started; Indoor fan motor breezes, air door may swings or stops, and other peripharal equipments is closed.
- (2) Startup status: During defrosting function, cooling function and fan only function the increasing oxygen working. Outdoor fan working, if the compressor is off ,the outdoor fan still working with the increasing

oxygen device.

In heating function:

When defrosting, the increasing oxygen device will not work.

When indoor fan is working the oxygen device will working

4.10 E2PROM contents as follows:

- ☞ The memory function of power down is available, and the auto recovery function of power on is optional. (In auto, heating, cooling, or dry status, press the “sleeping” button 10 times within 5 seconds, and the auto recovery function of power on can be set on/off. If the buzzer rings 4 times, the the auto recovery function of power on is available; If the buzzer rings 2 times, the the auto recovery function of power on is unavailable.)
- ☞ If there is no EEPROM, the unit is taken off the ‘off’ function of the memory function of power down. But the memory function of power down can also be set on/off, and the data is the default value of chip.

4.7 Alarm from indoor fan motor:

10 seconds later after the indoor fan motor is charged, and the impulse from fan motor is not detected, then stop outputting voltage to indoor fan motor, stand by for 30 seconds, then charge the fan motor again and there is still no impulse from fan motor, then send alarm signals.

4.8 Manual defrosting:

when the wire controller is on, choose high wind, 30°C, and press the sleeping button for 6 times within 5 seconds, and after the buzzer rings 3 times, the air conditioner enter manual defrosting mode, which is the same as heating defrosting.

express mode of malfunction:

HSU-09RA03

Abnormal mode	Wrong express	indoor	outdoor	Auto recovery	Cause of malfunction
	PowerTimer Run				
Indoor temp.sensitive resistance abnormal	★ ■ ■	*		*	Sensor is shorted out or opened circuit
Temp. sensor resistance of heat exchanging abnormal	★ □ □	*		*	Sensor is shorted out or opened circuit
Indoor fan motor abnormal	■ □ ★	*			Indoor fan motor don't feed back
EEPROM abnormal	★ □ ■	*			Data error or no EEPROM
explanation	□ on ★ flash ■ off	* reprints having this function			

Wiring diagram

Indoor Diagram

0010548550

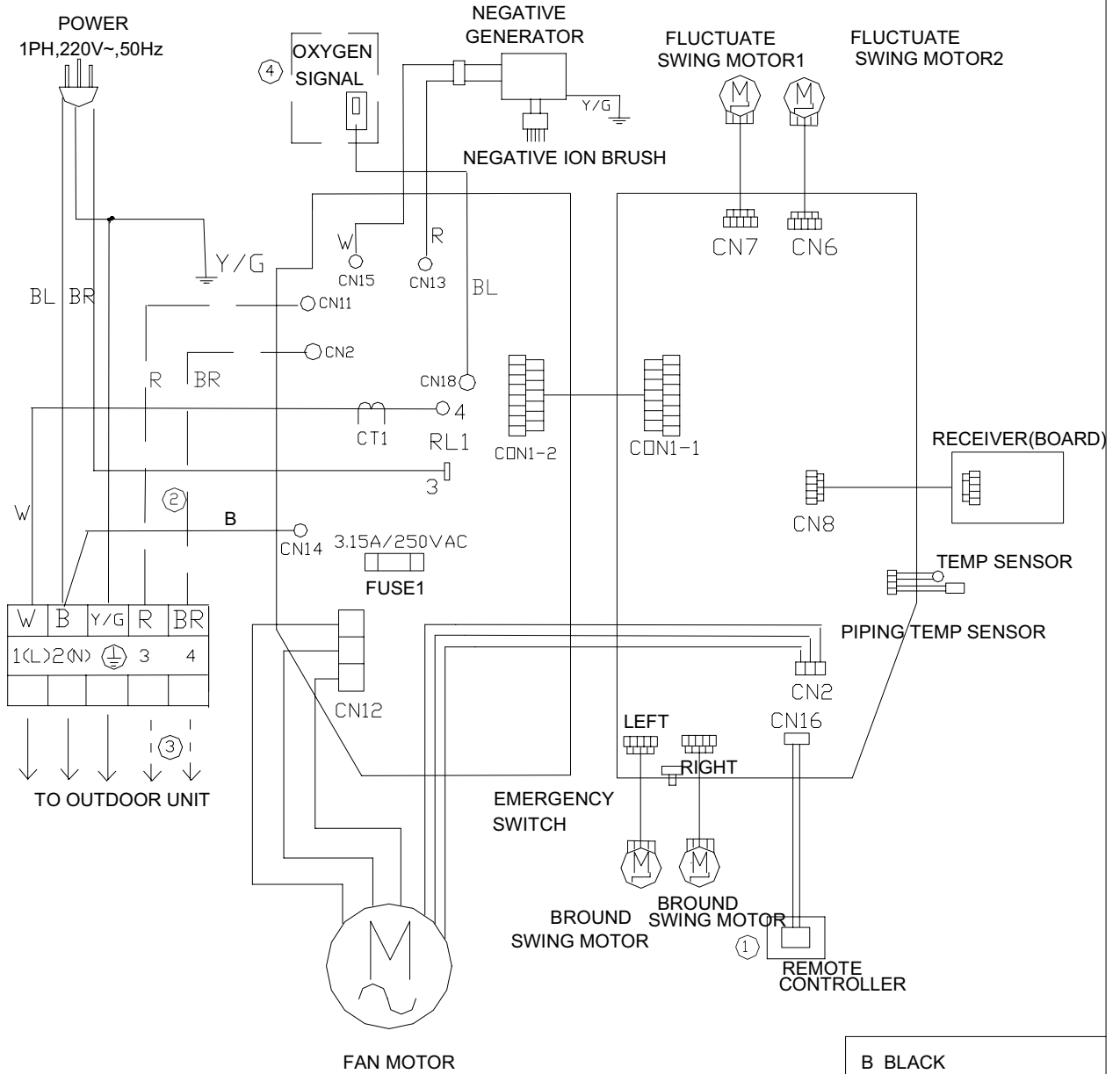

NOTING: DASHED UNIT IS OPTIONAL UNIT. ONLY COOLING TYPE IS NOT HAVE.

- B BLACK
- R RED
- BR BROWN
- BL BLUE
- Y/G YELLOW/GREEN
- W WHITE

OUTDOOR DIAGRAM

0010548551

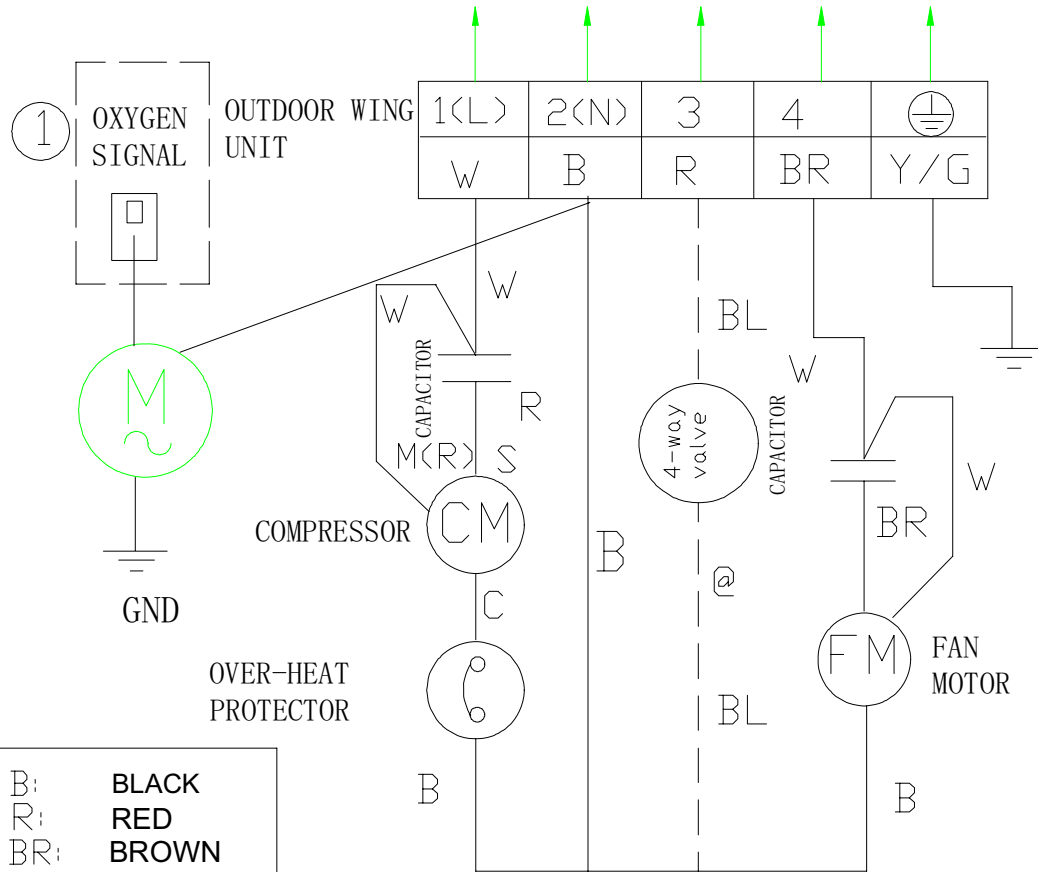

- B: BLACK
- R: RED
- BR: BROWN
- BL: BLUE
- W: WHITE
- Y/G: YELLOW/GREEN

NOTING

REMOVAL OF LOCKING TERMINAL CONTACT TERMINAL CONTACT COMES WITH LOCKING STRUCTURE

WIHTOUT HEATING FUNCTION , WITHOUT THE PART IN DASHED FRAME.

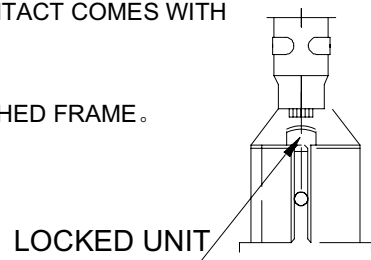

CIRCUIT DIAGRAM

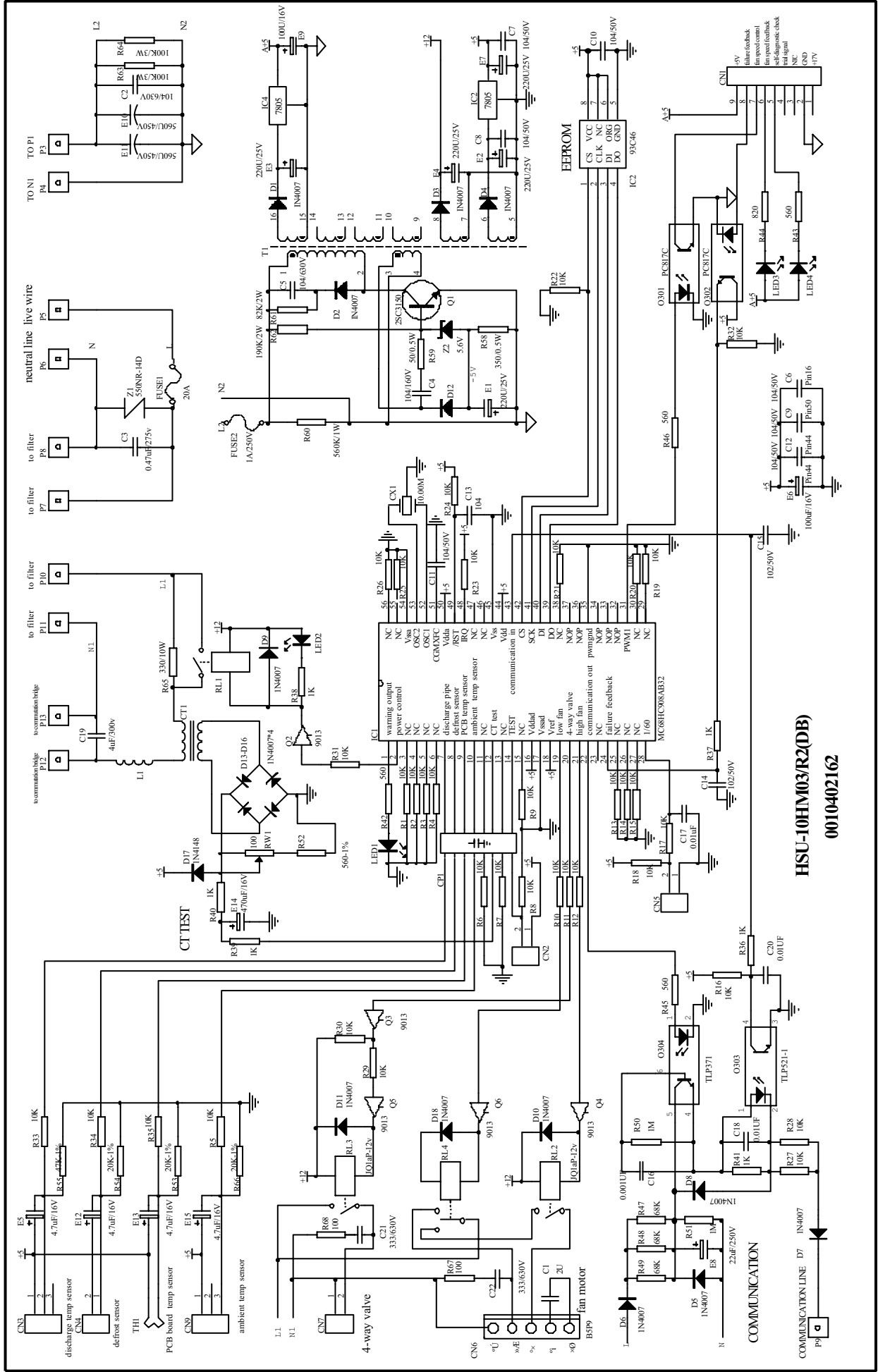





HSU-10HM03/R2(DB)

0010402162

TROUBLE SHOOTING

Trouble Shooting

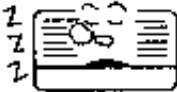
Before asking for service, check the following first.

	Phenomenon	Cause or check points
Normal Performance inspection	The system does not restart immediately. 	<ul style="list-style-type: none"> ▪ When unit is stopped, it won't restart immediately until 3 minutes have elapsed to protect the system. • When the electric plug is pulled out and reinserted, the protection circuit will work for 3 minutes to protect the air conditioner.
	Noise is heard. 	<ul style="list-style-type: none"> • During unit operation or at stop, a swishing or gurgling noise may be heard. At first 2-3 minutes after unit start, this noise is more noticeable. (This noise is generated by refrigerant flowing in the system.) • During unit operation, a cracking noise may be heard. This noise is generated by the casing expanding or shrinking because of temperature changes. • Should there be a big noise from air flow in unit operation, air filter may be too dirty.
	Smells are generated.	<ul style="list-style-type: none"> • This is because the system circulates smells from the interior air such as the smell of furniture, cigarettes.
	Mist or steam are blown out. 	<ul style="list-style-type: none"> • During COOL or DRY operation, indoor unit may blow out mist. This is due to the sudden cooling of indoor air.
Multiple check	Does not work at all. 	<ul style="list-style-type: none"> • Is power plug inserted? • Is there a power failure? • Is fuse blown out?
	Poor cooling 	<ul style="list-style-type: none"> • Is the air filter dirty? Normally it should be cleaned every 15 days. • Are there any obstacles before inlet and outlet? • Is temperature set correctly? • Are there some doors or windows left open? • Is there any direct sunlight through the window during the cooling operation? (Use curtain) • Are there too much heat sources or too many people in the room during cooling operation?

Application temp. range of air conditioner -7°C~43°C.

REFRIGERATING CYCLE DIAGRAM

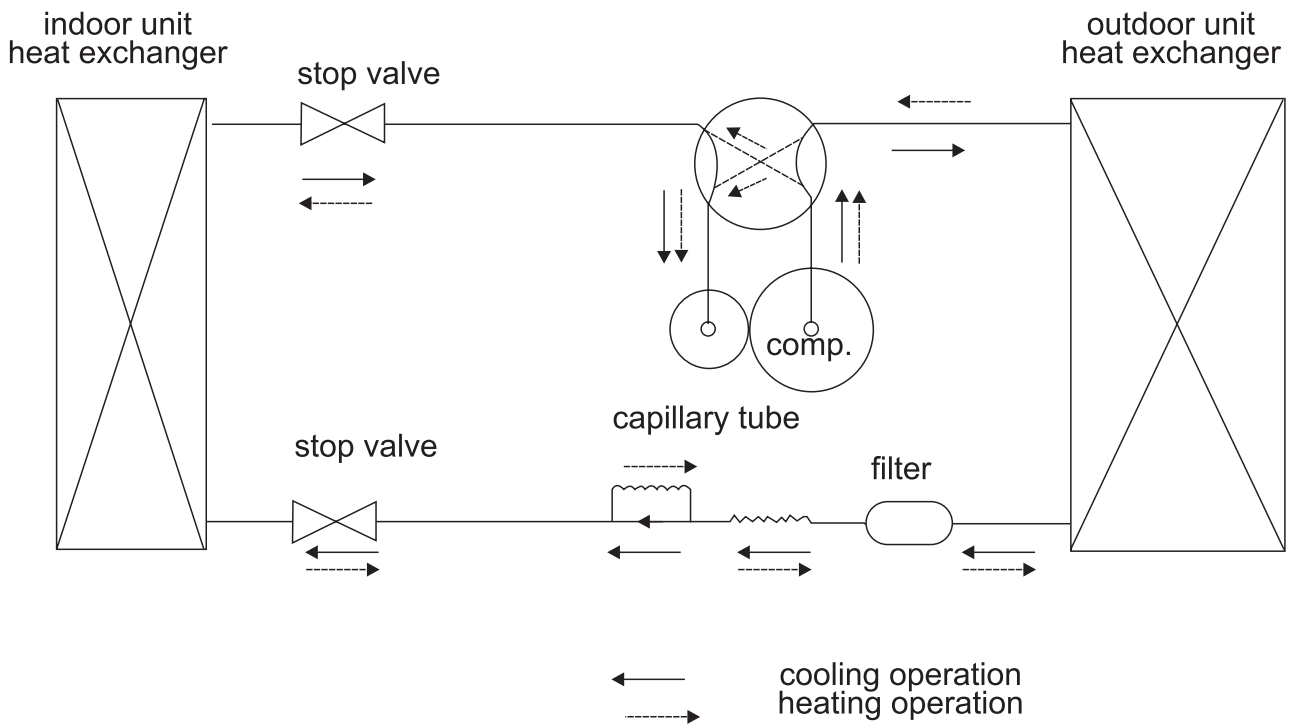

Noise level test chart and air velocity distribution

Noise level test chart and air velocity distribution

Noise level test chart

MODEL: HSU-12HT03/R2(DB) HSU-10HT03/R2(DB)

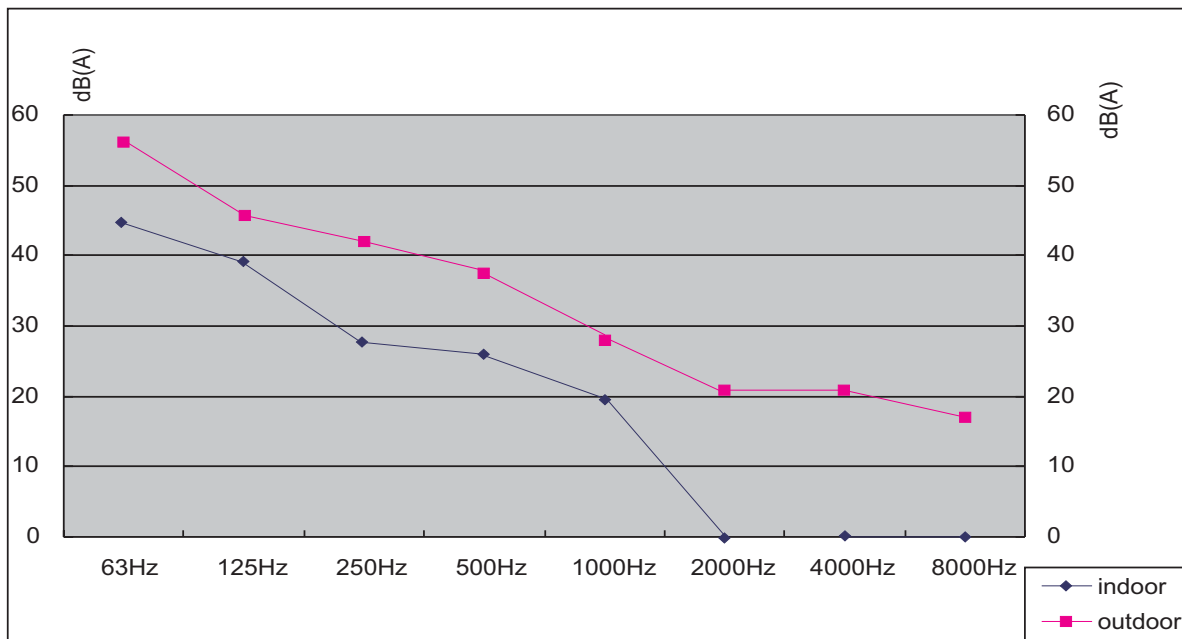

Noise level test chart and air velocity distribution

Air velocity distribution

MODEL: HSU-12HT03/R2(DB) HSU-10HT03/R2(DB)

Air velocity distribution

Fig 1
top view
flow control panel horizal
lourer:center

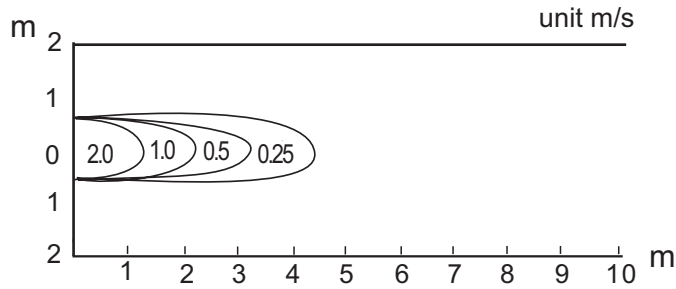

Fig 2
top view
flow control panel horizal
lourer:right and left

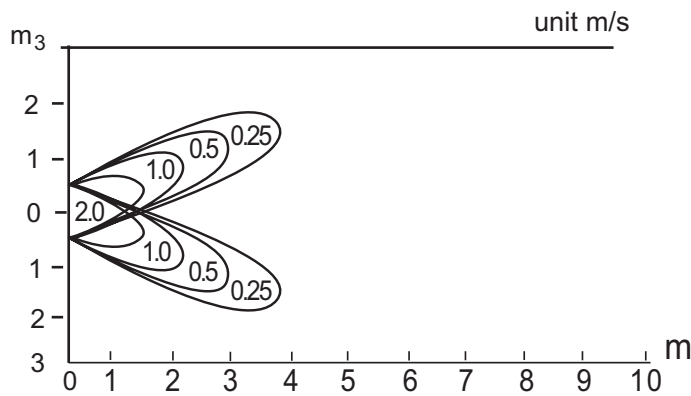

Fig 3
top view
flow control panel horizal
lourer:center

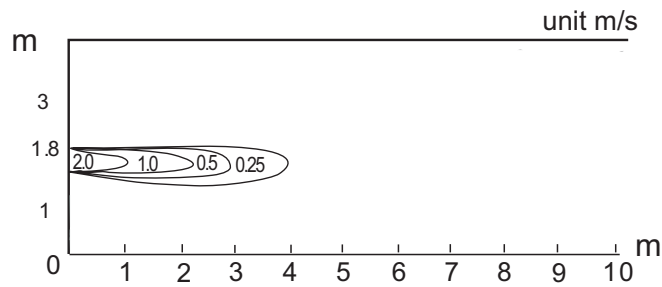
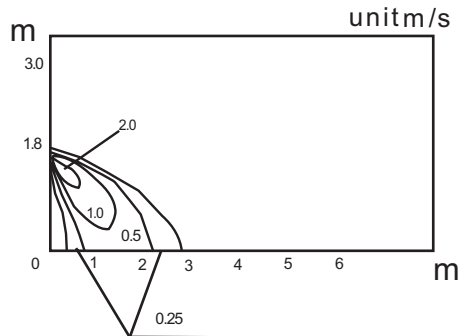

Fig 4
top view
flow control panel vertical
lourer:center



Condition
Fan speed:high
Operation mode:fan
Voltage:230V,50Hz

Installation manual

Installation Manual of Room Air Conditioner

- Read this manual before installation.
- Explain sufficiently the operating means to the user according to this manual.

Necessary Tools for Installation

- | | | | |
|--------------------------------|-----------------------------------|-----------------------------------------------------|------------|
| 1. Driver | 5. Torque wrench (17mm,22mm,24mm) | 9. Nipper | 12. Reamer |
| 2. Hacksaw | 6. Pipe cutter | 10. Gas leakage detector or soap-and-water solution | |
| 3. Hole core drill | 7. Flaring tool | 11. Measuring tape | |
| 4. Spanner (14,17,19 and 2 mm) | 8. Knife | | |

Drawing for the installation of indoor and outdoor units

※ The models adopt HFC free refrigerant R410A

Accessory parts

No.	Accessory parts	Number of articles
①	Remote controller	1
②	R-03 dry battery	2
③	Mounting plate	1
④	Drain hose	1
⑤	$\phi 4 \times 50$ Steel nail, cement	6
⑥	Main pipes	1
⑦	$\phi 4 \times 25$ Screw Plastic cap	4
⑧	Drain-elbow	1
⑨	Cover	1
⑩	Cushion	4
⑪	Connecting cable	1
⑫	Pipe supporting plate	1

Optional parts for piping

Mark	Parts name
Ⓐ	Non-adhesive tape
Ⓑ	Adhesive tape
Ⓒ	Saddle(L.S) with screws
Ⓓ	Connecting electric cable for indoor and outdoor
Ⓔ	Drain hose
Ⓕ	Heat insulating material
Ⓖ	Piping hole cover

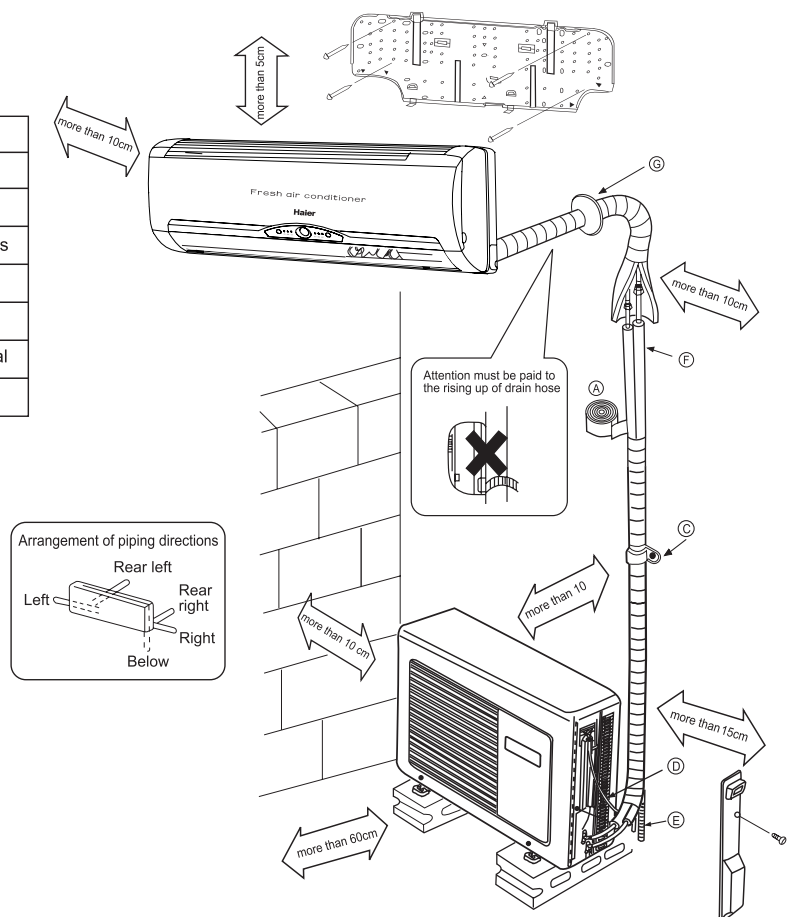

※ The marks from Ⓐ to Ⓖ in the figure are the parts' numbers

※ The distance between the indoor unit and the floor should be more than 2m.

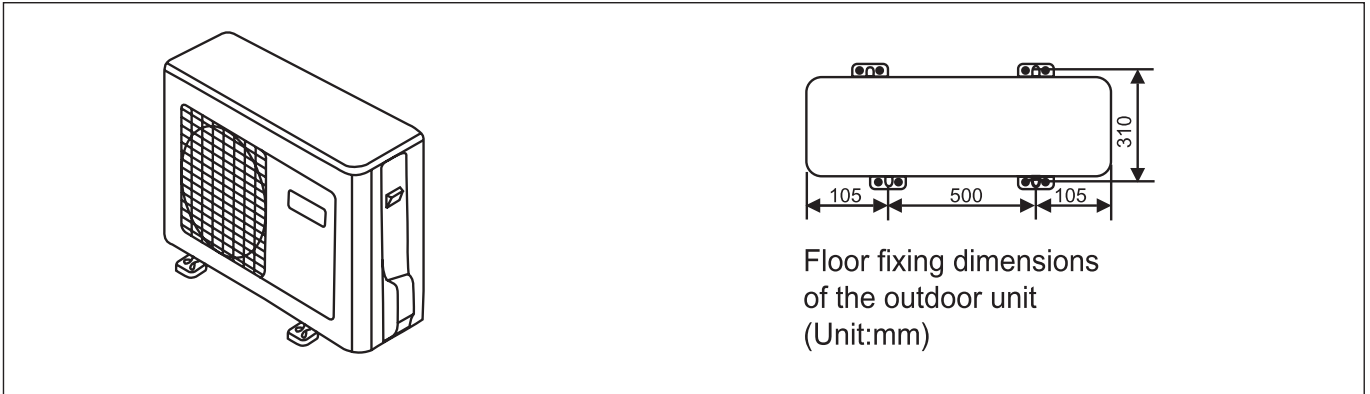

Floor fixing dimensions of the outdoor unit (Unit:mm)

Fixing of outdoor unit

- Fix the unit to concrete or block with bolts ($\phi 10\text{mm}$) and nuts firmly and horizontally.
- When fitting the unit to wall surface, roof or rooftop, fix a supporter surely with nails or wires in consideration of earthquake and strong wind.
- If vibration may affect the house, fix the unit by attaching a vibration-proof mat.

Indoor Unit

Selection of Installation Place

Outdoor Unit

- Place, robust not causing vibration, where the body can be supported sufficiently.
- Place, not affected by heat or steam generated in the vicinity, where inlet and outlet of the unit are not disturbed.
- Place, possible to drain easily, where piping can be connected with the outdoor unit.
- Place, where cold air can be spread in a room entirely.
- Place, nearby a power receptacle, with enough space around. (Refer to drawings).
- Place where the distance of more than 1m from televisions, radios, wireless apparatuses and fluorescent lamps can be left.
- In the case of fixing the remote controller on a wall, place where the indoor unit can receive signals when the fluorescent lamps in the room are lightened.

- Place, which is less affected by rain or direct sunlight and is sufficiently ventilated.
- Place, possible to bear the unit, where vibration and noise are not increased.
- Place, where discharged wind and noise do not cause a nuisance to the neighbors.
- Place, where a distance marked \leftrightarrow is available as illustrated in the above figure.

Power Source

- Before inserting power plug into receptacle, check the voltage without fail. The power source is the same as the corresponded name plate.
- Install an exclusive branch circuit of the power.
- A receptacle shall be set up in a distance where the power cable can be reached. Do not extend the cable by cutting it.

Selection of Pipe

- To this unit, both liquid and gas pipes shall be insulated as they become low temperature in operation.
- Use optional parts for piping set or pipes covered with equivalent insulation material.

Liquid pipe (ϕ)	6.35mm (1/4")
Gas pipe (ϕ)	12.7mm(1/2")

Indoor Unit

1 Fitting of the Mounting Plate and Positioning of the Wall Hole

When the mounting plate is first fixed

- 1 Carry out, based on the neighboring pillars or lintels, a proper leveling for the plate to be fixed against the wall, then temporarily fasten the plate with one steel nail.
- 2 Make sure once more the proper level of the plate, by hanging a thread with a weight from the central top of the plate, then fasten securely the plate with the attachment steel nail.
- 3 Find the wall hole location A using a measuring tape.

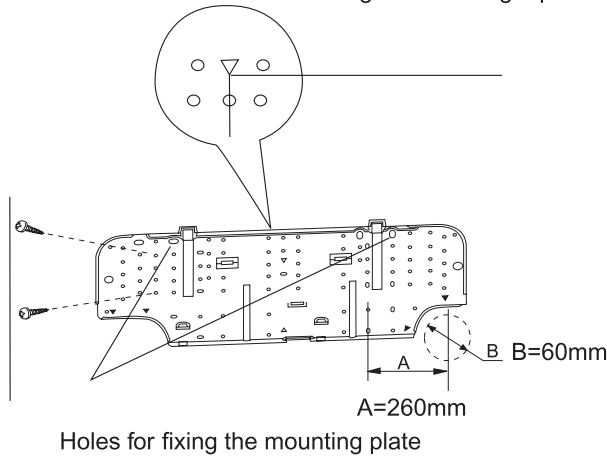

Fit the level line

When the paper pattern is used

- 1 Stick a paper pattern on the wall horizontally
- 2 Position by using the pattern then remove the pattern

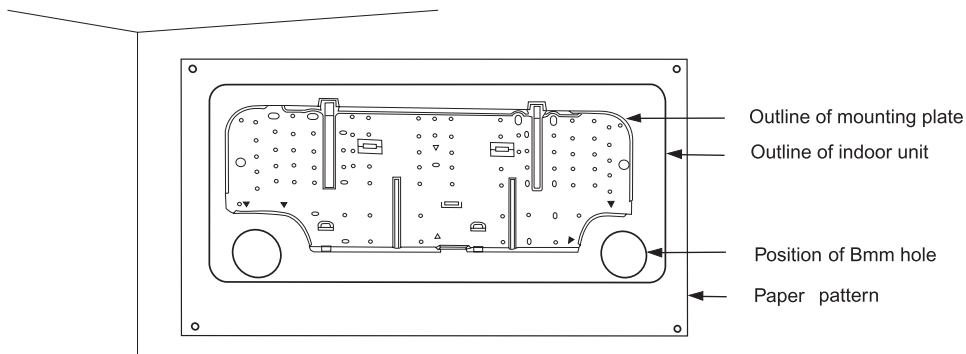

When the mounting plate is fixed to side bar and lintel

- Fix to side bar and lintel a mounting bar, Which is separately sold, and then fasten the plate to the fixed mounting bar.
- Refer to the previous article, "When the mounting plate is first fixed", for the position of wall hole.

2 Making a Hole on the Wall and Fitting the Piping Hole Cover

- Make a hole of Bmm in diameter, slightly descending to outside the wall.
- Install piping hole cover and seal it off with putty after installation.

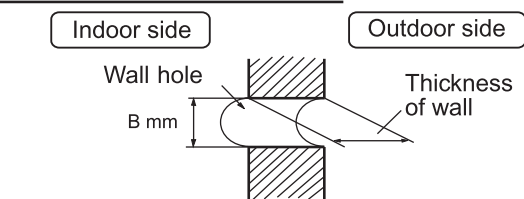

(Section of wall hole) © Piping hole pipe

Indoor Unit

3 Installation of the Indoor Unit

Drawing of pipe

[Rear piping]

- Draw pipes and the drain hose, then fasten them with the adhesive tape.

[Left • Left-rear piping]

- In case of left side piping, cut away, with a nipper, the lid for left piping.
- In case of left-rear piping, bend the pipes according to the piping direction to the mark of hole for left-rear piping which is marked on heat insulation materials.

1. Insert the drain hose into the dent of heat insulation materials of indoor unit.
2. Insert the indoor/outdoor electric cable from backside of indoor unit, and pull it out on the front side, then connect them.
3. Coat the flaring seal face with refrigerant oil and connect pipes.
Cover the connection part with heat insulation materials closely, and make sure fixing with adhesive tape.

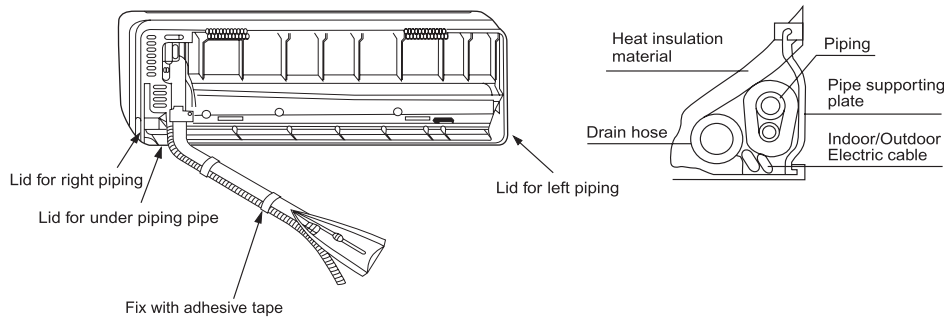

- Indoor/outdoor electric cable and drain hose must be bound with refrigerant piping by protecting tape.

[Other direction piping]

- Cut away, with a nipper, the lid for piping according to the piping direction and then bend the pipe according to the position of wall hole. When bending, be careful not to crash pipes.
- Connect beforehand the indoor/outdoor electric cable, and then pull out the connected to the heat insulation of connecting part specially.

Fixing the indoor unit body

- Hang surely the unit body onto the upper notches of the mounting plate. Move the body from side to side to verify its secure fixing.
- In order to fix the body onto the mounting plate, hold up the body aslant from the underside and then put it down perpendicularly.

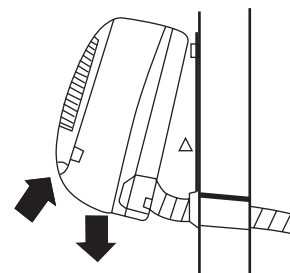

4 Connecting the indoor/outdoor Electric Cable

Removing the wiring cover

- Remove terminal cover at right bottom corner of indoor unit, then take off wiring cover by removing its screws.

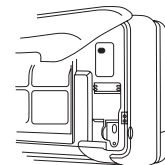

When connecting the cable after installing the indoor unit

1. Insert from outside the room cable into left side of the wall hole, in which the pipe has already existed.
2. Pull out the cable on the front side, and connect the cable making a loop.

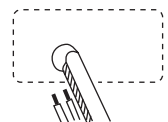

Indoor Unit

When connecting the cable before installing the indoor unit

- Insert the cable from the back side of the unit, then pull it out on the front side.
 - Loosen the screws and insert the cable ends fully into terminal block, then tighten the screws.
 - Pull the cable slightly to make sure the cables have been properly inserted and tightened.
 - After the cable connection, never fail to fasten the connected cable with the wiring cover.
- Note: When connecting the cable, confirm the terminal number of indoor and outdoor units carefully. If wiring is not correct, proper operation can not be carried out and will cause defect.
1. If the supply cord is damaged, it must be replaced by the manufacturer or its service agent or a similar qualified person. The type of connecting wire is H05RN-F or H07RN-F.
 2. If the fuse on PC board is broken please change it with the type of T.3.15A/250V.
 3. The wiring method should be in line with the local wiring standard.
 4. After installation, the power plug should be easily reached.

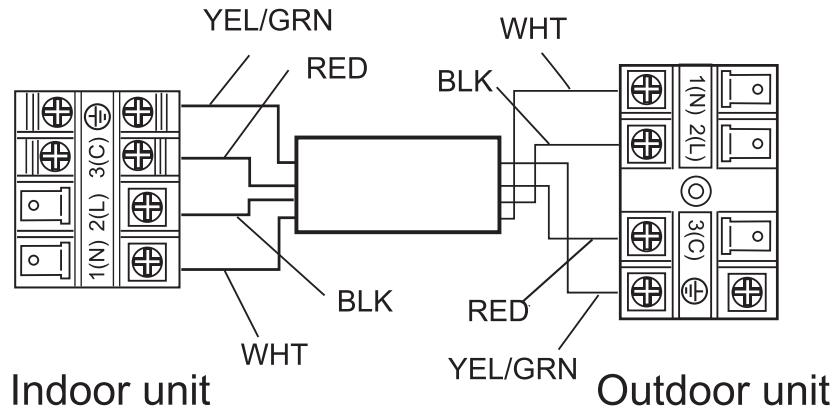
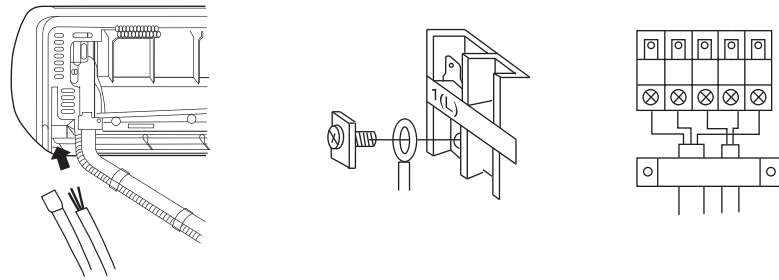

Outdoor Unit

1 Installation of Outdoor Unit

Install according to Drawing for the installation of indoor and outdoor units

2 Connection of Pipes

- Apply refrigerant oil on half union and flare nut.
- To bend a pipe, give the roundness as large as possible not to crush the pipe.
- Connecting the pipe of gas side first makes working easier.
- The connection pipe is specialized for R410A
- The max length of connection pipe is 15m
- The max distance between the indoor unit and the outdoor unit is m

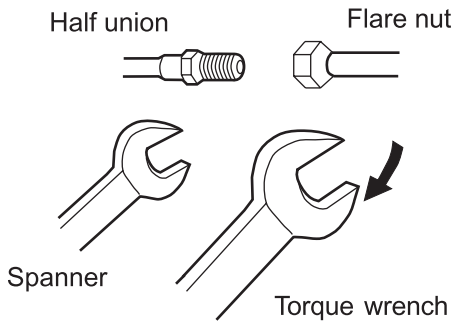

Forced fastening without careful centering may damage the threads and cause a leakage of gas.

Pipe Diameter (ϕ)	Fastening Torque
Liquid Side 6.35mm(1/4")	18N.m
Gas Side 12.7mm(1/2")	55N.m

3 Connection

- Use the same method on indoor unit. Loosen the screws on terminal block and insert the plugs fully into terminal block, then tighten the screws.
- Insert the cable according to terminal number in the same manner as the indoor unit.
- If wiring is not correct, proper operation can not be carried out and controller may be damaged.
- Fix the cable with a damp.

4 Attaching Drain-Elbow

- If the drain-elbow is used, please attach it as figure.

Note: Only for heat pump unit.

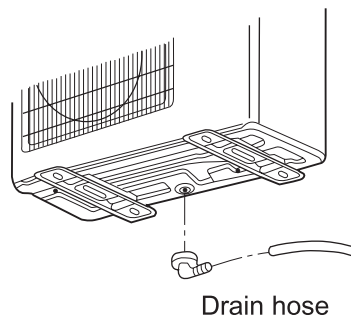

Outdoor Unit

5 Purging Method: To use vacuum pump

① Detach the service port's cap of 3-way valve, the valve rod's cap for 2-way valve and 3-way's, connect the service port into the projection of charge hose (low) for gaugemanifold. Then connect the projection of charge hose (center) for gaugemanifold into vacuum pump.

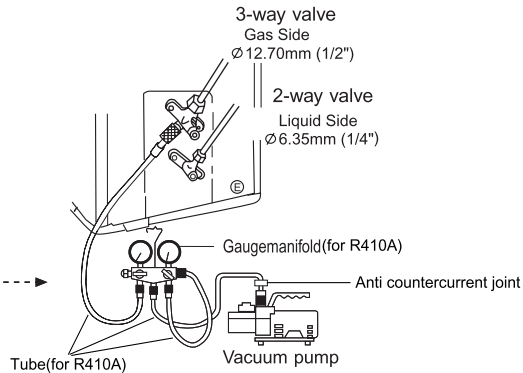

② Open the handle at low in gaugemanifold, operate vacuum pump. If the scale-moves of gauge (low) reach vacuum condition in a moment, check ① again.

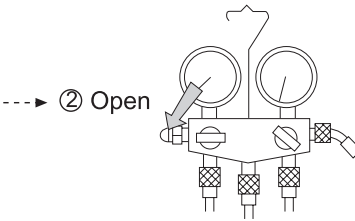

③ Vacuumize for over 15min. And check the level gauge which should read -0.1 MPa (-76 cm Hg) at low pressure side. After the completion of vacuumizing, close the handle 'Lo' in gaugemanifold and stop the operation of the vacuum pump. Check the condition of the scale and hold it for 1-2min. If the scale-moves back in spite of tightening, make flaring work again, the return to the beginning of ③.

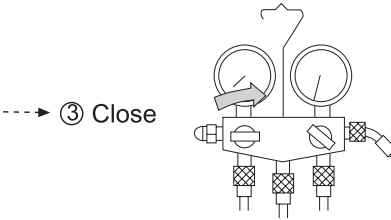

④ Open the valve rod for the 2-way valve to an angle of anticlockwise 90 degree. After 6 seconds later, close the 2-way valve and make the inspection of gas leakage.

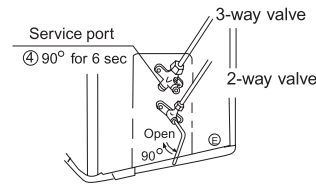

⑤ No gas leakage?

In case of gas leakage, tighten parts of pipe connection. If leakage stops, then proceed ⑥ steps.

If it does not stop gas leakage, discharge whole refrigerants from the service port. After flaring work again and vacuumize, fill up prescribed refrigerant from the gas cylinder.

⑥ Detach the charge hose from the service port, open 2-way valve and 3-way. Turn the valve rod anticlockwise until hitting lightly.

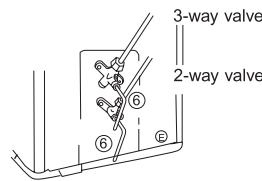

⑦ To prevent the gas leakage, turn the service port's cap, the valve rod's cap for 2-way valve and 3-way's a little more than the point where the torque increases suddenly.

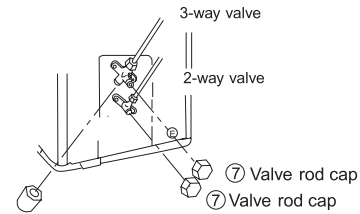

⑧ After attaching the each caps, check the gas leakage around the caps.

CAUTION:

1.If the refrigerant of the air conditioner leaks, it is necessary to make all the refrigerant out. Vacuumize first, then charge the liquid refrigerant into air conditioner according to the amount marked on the name plate.

2.Please do not let other cooling medium, except specified one (R410A), or air to enter into the cooling circulation system. Otherwise, there will be abnormal high pressure in the system to make it crack and lead to personnel injuries.

1 Power Source Installation

- The power source must be exclusively used for air conditioner. (Over 10A)
- In the case of installing an air conditioner in a moist place. please install an earth leakage breaker.
- For installation in other places, use a circuit breaker as far as possible.

2 Cutting and Flaring Work of Piping

- Pipe cutting is carried out with a pipe cutter and burs must be removed.
- After inserting the flare nut, flaring work is carried out.

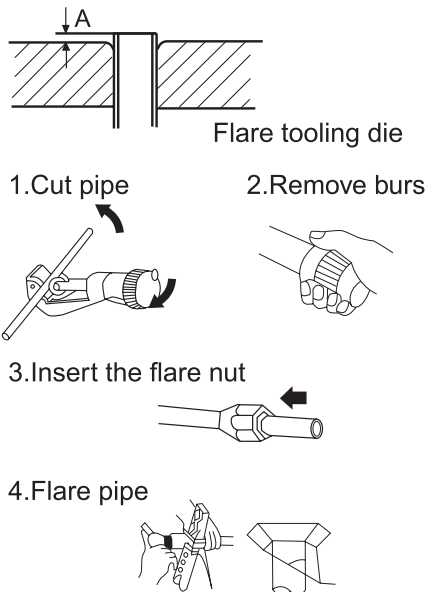

Pipe diameter	Size A (mm)		
	R410A	R22	
	clutch Standard		British Standard
6.35mm(1/4")	0~0.5	0.5~1.0	1.0~1.5
12.7mm(1/2")	0~0.5	0.5~1.0	1.0~1.5

Correct	Incorrect				
	Lean	Damage of flare	Crack	Partial	Too outside

3 On Drainage

- Please install the drain hose so as to be downward slope without fail.
- Please don't do the drainage as shown below.

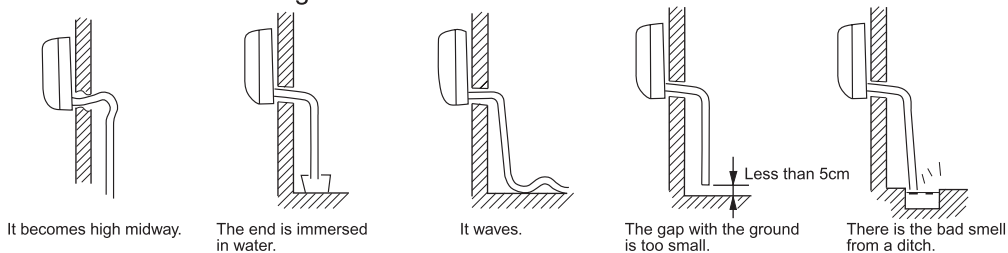

- Please pour water in the drain pan of the indoor unit, and confirm that drainage is carried out surely to outdoor.
- In case that the attached drain hose is in a room, please apply heat insulation to it without fail.

Check for Installation and Test Run

- Please kindly explain to our customers how to operate through the instruction manual.

Check Items for Test Run

- Put check mark ✓ in boxes
- | | | |
|------------------------------------------------------------------------------------------------------------------|----------------------------------------------------------------------|------------------------------------------------------------------------------------------|
| <input type="checkbox"/> Gas leak from pipe connecting? | <input type="checkbox"/> Is drainage securely carried out? | <input type="checkbox"/> Is the lamp normally lighting? |
| <input type="checkbox"/> Heat insulation of pipe connecting? | <input type="checkbox"/> Is the earth line securely connected? | <input type="checkbox"/> Are cooling and heating (when in heat pump) performed normally? |
| <input type="checkbox"/> Are the connecting wirings of indoor and outdoor firmly inserted to the terminal block? | <input type="checkbox"/> Is the indoor unit securely fixed? | <input type="checkbox"/> Is the operation of room temperature regulator normal? |
| <input type="checkbox"/> Is the connecting wiring of indoor and outdoor firmly fixed? | <input type="checkbox"/> Is power source voltage abided by the code? | |
| | <input type="checkbox"/> Is there any noise? | |

- Paper Pattern for Indoor Unit Installation
Please use this sheet to site the unit
- Leave at Least 50mm between the top of the unit and the ceiling

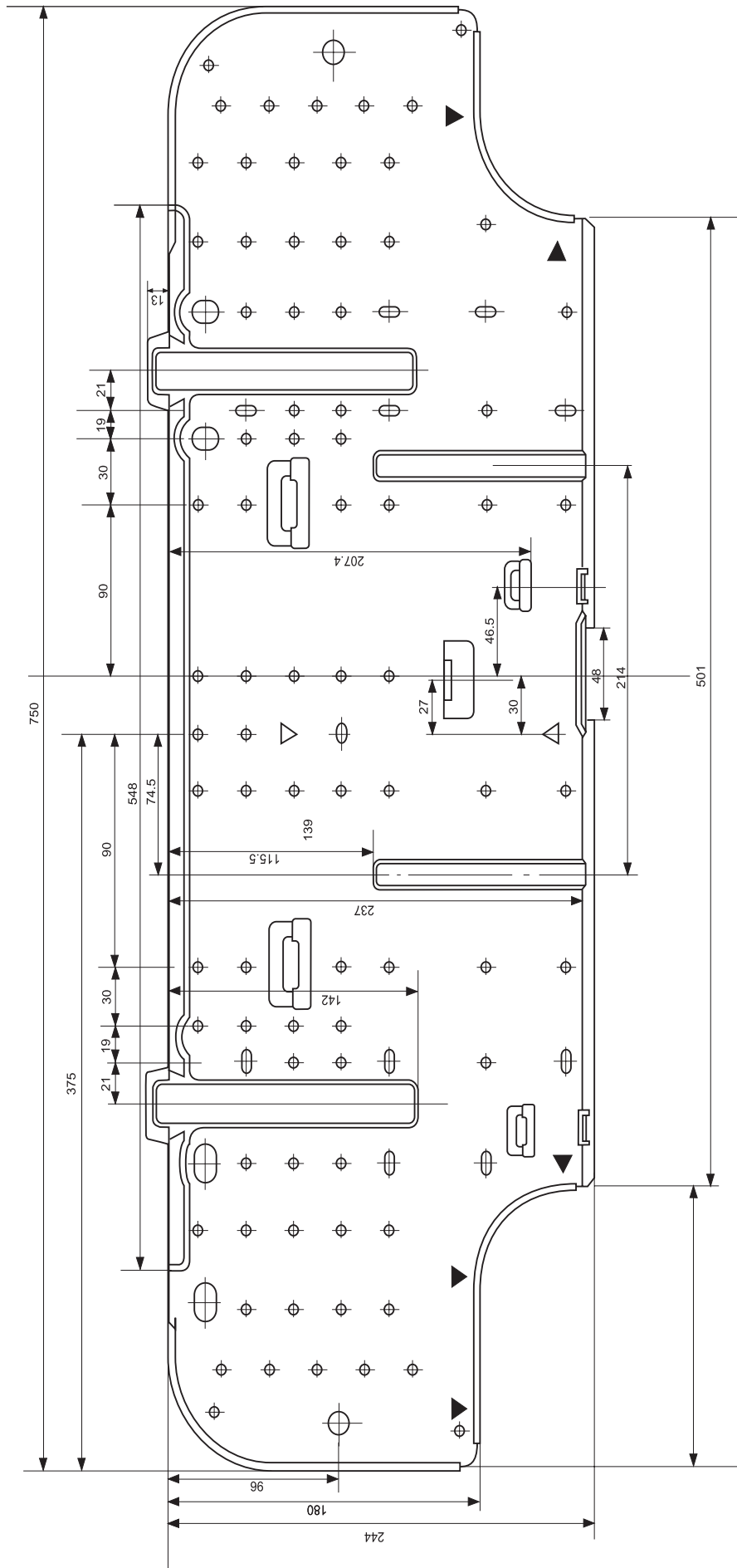

Sincere Forever

Haier Group

Haier Industrial Park, No.1, Haier Road

266101, Qingdao, China

<http://www.haier.com>