

# SERVICE MANUAL

---



HCFU-42CH03



HCFU-42HK03

### ● Features

- High energy efficiency
- Fixed frequency
- Long distribution pipe and high drop
- Flexible and easy installation
- Fresh air hole, more natural, more healthy
- Optional safety devices and much more precision control device

**CONTENTS**

Contents.....	2
1. Description of products & features.....	3
2. Specification.....	5
3. Safety precaution.....	8
4. Net dimension.....	10
5. Installation instructions.....	11
6. Parts and functions.....	12
7. Controller functions.....	13
8. Refrigerant circuit.....	14
9. Electrical control functions.....	15
10. Electrical data.....	26
11. Troubleshooting.....	30

## 1. DESCRIPTION OF PRODUCTS & FEATURES

### 1.1. Products code explanation

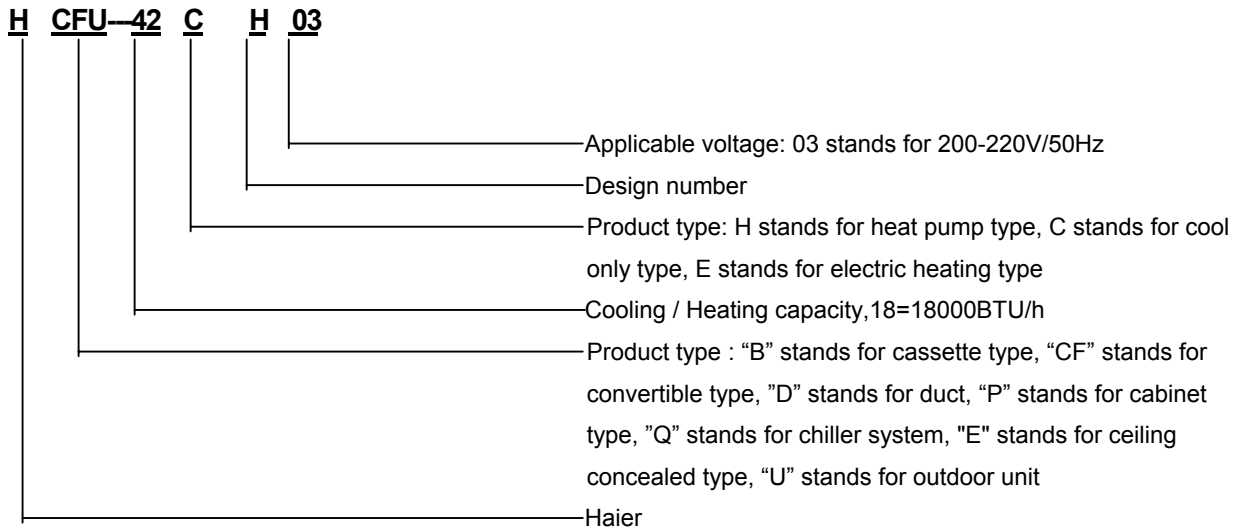

### 1.2 Brief Introduction for T1、T2、T3 working condition

Type of Air Conditioner	Climate type		
	T1	T2	T3
Cooling Only	18 °C~43°C	10°C~35°C	21°C~52°C
Heat pump	-7°C~43°C	-7°C~35°C	-7°C~52°C
Electricity Heating	~43°C	~35°C	~52°C

### 1.3 Operating Range of Air Conditioners

Temp.		Mode	Rated	Maximum	Minimum
Cooling	Indoor	DB °C	27	32	18
		WB °C	19	23	14
	Outdoor	DB °C	35	43	10
		WB °C	24	26	6
Heating	Indoor	DB °C	20	27	15
		WB °C	14.5	---	--
	Outdoor	DB °C	7	24	-7
		WB °C	6	18	---

## 1.4 Product features

### Flexible and easy installation

The outdoor can meet the higher request of installation. From the specifications, you will find for each unit, how long and how high the piping will be, which will be convenient for design and installation.

### Optional safety devices and much more precision control device

- a. Ambient **temperature sensor**, coil temperature sensor and compressor temperature sensor make the temperature control and defrosting control more precise.
- b. **High/low pressure switch** can feel the discharging pipe pressure and suction pipe pressure on time and precisely. If the pressure is too low or too high, it will stop the compressor to prevent it being damaged for the sake of pressure.
- c. **3 minutes delay protection** for the compressor, the device can protect the compressor from some damages and make the compressor have a long life.

### Silent operation

### New design of long piping length and large drop

### Optional installation mode

The indoor unit can be installed on the floor or to the ceiling, it is determined by the host favor and the room décor. It is more convenient to service and installation.

### Silent operation

The convertible unit is equipped with a high efficient, smooth, multi-blade centrifugal fan, which generates a powerful but gentle airflow to any corner in the room.

### Space-saving design

An innovative fan and the ultra thin heat exchanger result in the ultra thin convertible unit. Fully adjustable mounting brackets make it possible to install the unit even in the tightest places.

### Large angle air supplying

100° wide angle louvers and 70° wide angle blades design to make a precise control of the airflow, it equally distributes the comfortable air to every coner of the room

### Automatically control of airflow direction for fast temperature adjusting

### Central control function, if connected with a central controller

## 2. SPECIFICATION

item		Model		HCFU-42CH03		
Function				cooling	heating	
Capacity			BTU/h	42000	-----	
Capacity			kW	12.3	-----	
Sensible heat ratio				75%		
Total power input			W	4600	-----	
Max. power input			W	5700	-----	
<b>EER or COP</b>			W/W	2.67	-----	
Dehumidifying capacity			10 <sup>-3</sup> ×m <sup>3</sup> /h	4.7		
Power cable			section	5G×2.5mm <sup>2</sup>		
Signal cable			section	4G×0.75mm <sup>2</sup>		
Connecting cable			section			
Power source			N, V, Hz	3PH, 380-400V, 50HZ		
Running /Max.Running current			A / A	8.5/9.3		
Start Current			A	50		
Class of anti electric shock				CLASS I	/	
Circuit breaker			A	30	/	
Max. operating pressure of heat side			Mpa	2.8	/	
Max. operating pressure of cold side			Mpa	2.8	/	
Indoor unit	Unit model (color)			HCFU-42CH03(WHITE)		
	Fan	Type × Number			centrifugal*4	
		Speed(H-M-L)		r/min	1250/1150/1100	
		Fan motor output power		kW	0.09	
		Air-flow(H-M-L)		m <sup>3</sup> /h	2000/1800/1400	
	Heat exchanger	Type / Diameter		mm	inner grooved/φ7	
		Total Area		m <sup>2</sup>	0.1	
		Temp. scope		℃	2-7	
	Dimension	External	(L×W×H)	mm×mm×mm	1580*700*240	
		Package	(L×W×H)	mm×mm×mm	1710*790*315	
	Control type (Remote /wired /model)				Remote	
	Noise level (H-M-L)			dB(A)	53/51/49	
Weight (Net / Shipping)			kg / kg	54/61		
Outdoor unit	Unit model (color)			HCFU-42CH03(WHITE)		
	Compressor	Model / Manufacture			JT160GABY1L DAKIN	
		Oil model			SUNISO 4GSDID-K/DAPHNE SE56P	
		Oil charging			1500-1700	
		Type			SCROLL	
		Protection type			inner protection	
		Starting method			Direct Start	
	Fan	Type × Number			Axial*1	
		Speed		r/min	740±50	
		Fan motor output power		kW	0.156	
		Air-flow(H-M-L)		m <sup>3</sup> /h	6000	
	Heat exchanger	Type / Diameter		mm	inner grooved/φ9.52	
		Row / Fin pitch			2/	
		Temp. scope		℃	cooling: 43~60 / heating: 6~7	
	Dimension	External	(L×W×H)	mm×mm×mm	1008×830×410	
		Package	(L×W×H)	mm×mm×mm	1130×930×490	
	Refrigerant control method			mm/mm	Capillary tube	
Defrosting				Automatic		
Noise level			dB(A)	62		
Weight (Net / Shipping)			kg / kg	95/100		
PIPING	Refrigerant	Type / Charge	g	R22/2500G		
	Pipe	Liquid	mm	φ9.52		
		Gas	mm	φ19.05		
	Connecting Method			Flared		
	Between I.D & O.D	MAX.Drop		m	30	
MAX.Piping length			m	50		

item		Model		HCFU-42HK03		
Function				cooling	heating	
Capacity			BTU/h	44000	48000	
Capacity			kW	12.9	14060	
Sensible heat ratio				75%		
Total power input			W	4600	4600	
Max. power input			W	5540	5220	
<b>EER or COP</b>			W/W	2.8	3.06	
Dehumidifying capacity			10 <sup>-3</sup> ×m <sup>3</sup> /h	4.7		
Power cable			section	5G×2.5mm <sup>2</sup>		
Signal cable			section	6G×0.75mm <sup>2</sup>		
Connecting cable			section			
Power source			N, V, Hz	3PH, 380-400V, 50HZ		
Running /Max.Running current			A / A	cooling 8.8/9.6 heating 8.6/9.2		
Start Current			A	50		
Class of anti electric shock				CLASS I	CLASS I	
Circuit breaker			A	30		
Max. operating pressure of heat side			Mpa	2.8	2.8	
Max. operating pressure of cold side			Mpa	2.8	2.8	
Indoor unit	Unit model (color)			HCFU-42HK03(WHITE)		
	Fan	Type × Number			centrifugal*4	
		Speed(H-M-L)		r/min	1250/1150/1100	
		Fan motor output power		kW	0.09	
		Air-flow(H-M-L)		m <sup>3</sup> /h	2000/1800/1400	
	Heat exchanger	Type / Diameter		mm	inner grooved/φ7	
		Total Area		m <sup>2</sup>	0.10	
		Temp. scope			°C	2-7
	Dimension	External	(L×W×H)	mm×mm×mm	1580*700*240	
		Package	(L×W×H)	mm×mm×mm	1710*790*315	
	Drainage pipe (material , I.D./O.D.)			mm	PP 20/25	
	Control type (Remote /wired /model)				Remote	
	Noise level (H-M-L)			dB(A)	53/51/49	
	Weight (Net / Shipping)			kg / kg	54/61	
Outdoor unit	Unit model (color)			HCFU-42HK03(WHITE)		
	Compressor	Model / Manufacture			JT160GABY1L DAKIN	
		Oil model			SUNISO 4GSDID-K/DAPHNE SE56P	
		Oil charging			1500-1700	
		Type			SCROLL	
		Protection type			inner protection	
		Starting method			Direct Start	
	Fan	Type × Number			Axial*2	
		Speed		r/min	840±50	
		Fan motor output power		kW	0.08*2	
		Air-flow(H-M-L)		m <sup>3</sup> /h	7000	
	Heat exchanger	Type / Diameter		mm	inner grooved/φ9.52	
		Row / Fin pitch			2/	
		Temp. scope			°C	cooling: 43~60 / heating: 6~7
	Dimension	External	(L×W×H)	mm×mm×mm	948*340*1250	
		Package	(L×W×H)	mm×mm×mm	1050*440*1375	
	Refrigerant control method			mm/mm	Capillary tube	
	Defrosting				Automatic	
	Noise level			dB(A)	62	
crankcase heater power			W	47		
Weight (Net / Shipping)			kg / kg	101/106		
PIPING	Refrigerant	Type / Charge		g	R22/2800G	
	Pipe	Liquid		mm	φ9.52	
		Gas		mm	φ19.05	
	Connecting Method				Flared	
Between I.D & O.D	MAX.Drop		m	30		
	MAX.Piping length		m	50		

Norminal condition: indoor temperature (cooling): 27°CDB/19°CWB, indoor temperature (heating): 20°CDB

Outdoor temperature(cooling): 35°CDB/24°CWB, outdoor temperature(heating): 7°CDB/6°CWB

The noise level will be measured in the third octave band limited values, using a Real Time Analyser calibrated sound intensity meter. It is a sound pressure noise level. The detailed method please refer to the following information:

mounting-on-ceiling unit:

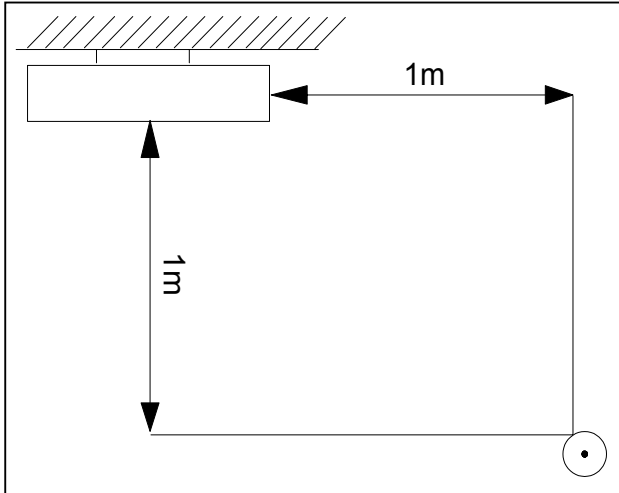

outdoor unit:

1.air outlet from side: the noise level is the average sound pressure level measured from front, left, right directions.

2.air outlet from top: the noise level is the average sound pressure level measured from front, back, left, right directions.

measured point:

$H$  ( height to the ground ) =  $(h$  ( unit height ) + 1m ) / 2

and, it is 1m to each side.

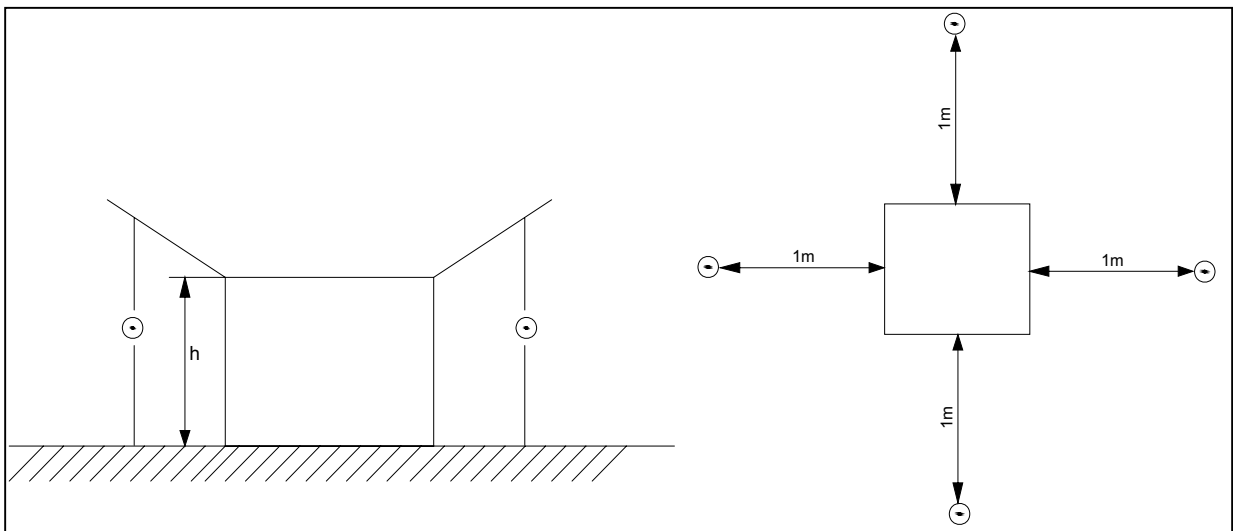

Note: ⊙ is the real time analyser position

### 3. Safety precaution

Carefully read the following information in order to operate the airconditioner correctly.

Below are listed three kinds of Safety Cautions and Suggestions.

**WARNING!** Incorrect operations may result in severe consequences of death or serious injuries.

**CAUTION!** Incorrect operations may result in injuries or machine damages; in some cases may cause serious consequences.

**INSTRUCTIONS:** These information can ensure the correct operation of the machine.

Be sure to conform with the following important Safety Cautions.

**The Safety Cautions should be at hand so that they can be checked at any time when needed.**

If the conditioner is transferred to the new user, this manual should be as well transferred to the new user.

## WARNING!

- If any abnormal phenomena is found (e. g.smell of firing), please cut off the power supply immediately, and contact the dealer to find out the handling method.

In such case, to continue using the conditioner will damage the conditioner, and may cause electrical shock or fire hazard.

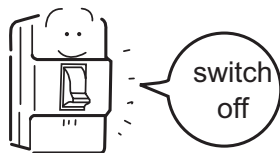

- After a long time use of air-conditioner the base should be checked for any damages.

If the damaged base is not repaired, the unit may fall down and cause accidents.



- Don't dismantle the outlet of the outdoor unit.

The exposure of fan is very dangerous which may harm human beings.



- When need maintenance and repairment, call dealer to handle it.

Incorrect maintenance and repairment may cause water leak, electrical shock and fire hazard.





### WARNING!

- **Installed electrical-leaking circuit breaker.**

It easily cause electrical shock without circuit breaker.

- **Air-conditioner can't be installed in the environment with inflammable gases because the inflammable gases near to air-conditioner may cause fire hazard.**

- **Please let the dealer be responsible for installing the conditioner.**

Incorrect installation may cause water leak, electrical shock and fire hazard.

- **Call the dealer to take measures to prevent the refrigerant from leaking.**

If conditioner is installed in a small room be sure to take every measure in order to prevent suffocation accident even in case of refrigerant leakage.

- **When conditioner is deinstalled or reinstalled dealer should be responsible for them.**

Incorrect installation may cause water leaking, electrical shock and fire hazard.

- **Connect earthing wire.**

Earthing wire should not be connected to the gas pipe, water pipe, lightning rod or phone line, in-correct earthing may cause shock.



Earthing

- **No goods or nobody is permitted to placed on or stand on outdoor unit.**

The falling of goods and people may cause accidents.



- **Don't operate the air-conditioner with damp hands.**

Otherwise will be shocked.



- **Only use correctly-typed fuse.**

May not use wire or any other materials replacing fuse, other-wise may cause faults or fire accidents.



- **Use discharge pipe correctly to ensure efficient discharge.**

Incorrect pipe use may cause water leaking.

### 4. Net dimension

#### 4.1 Indoor unit

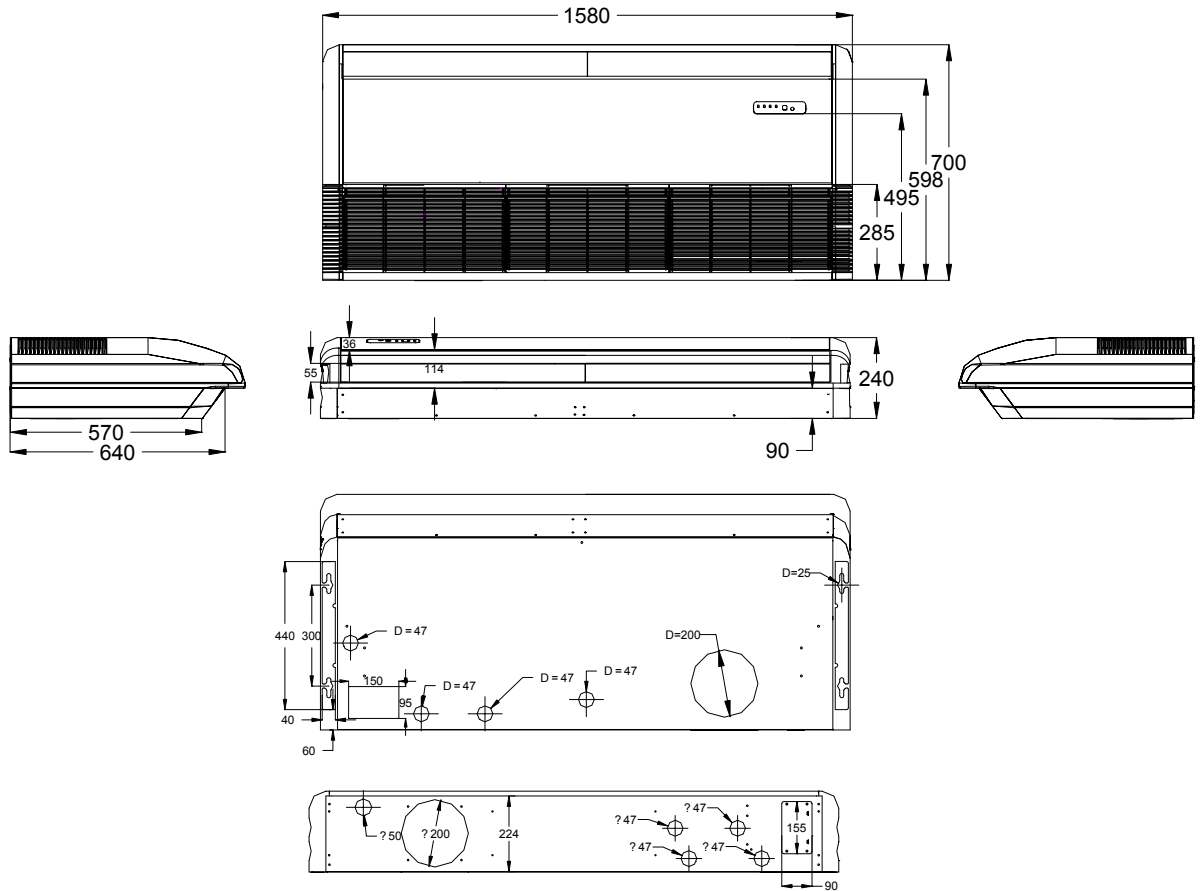

(mm)

#### 4.2 Outdoor unit

HCFU-42CH03

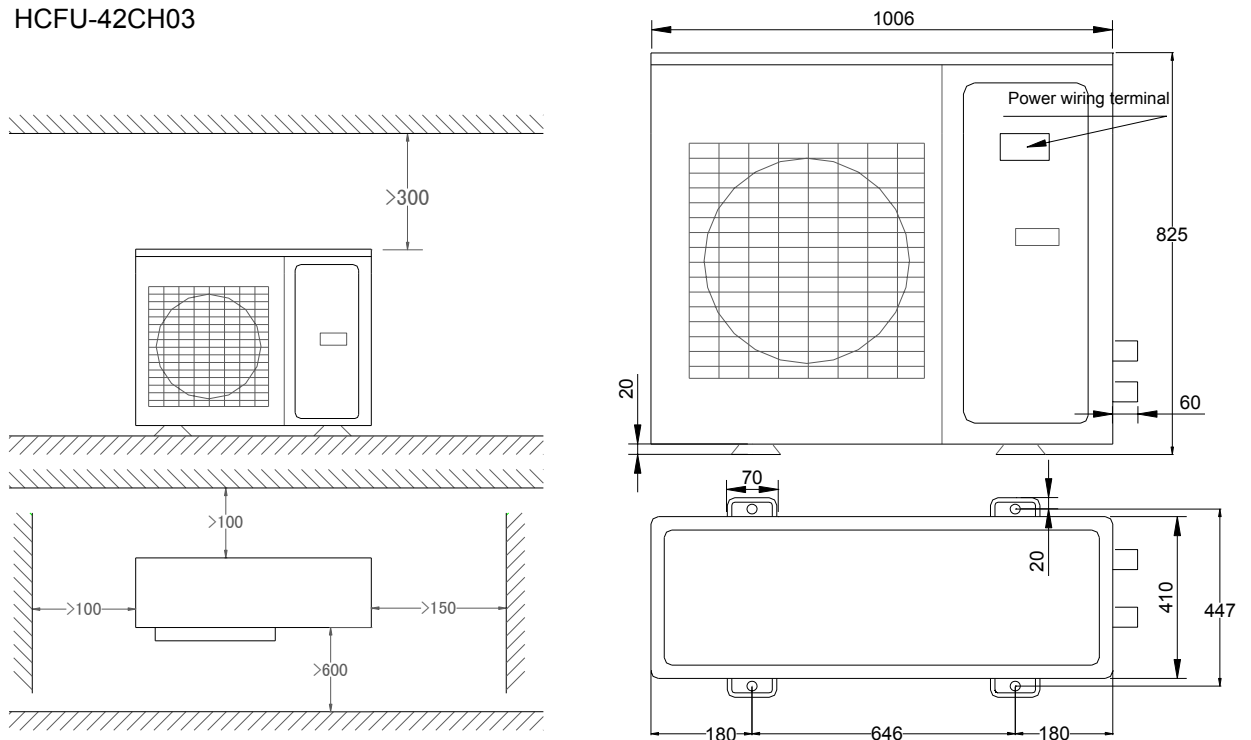

HCFU-42HK03

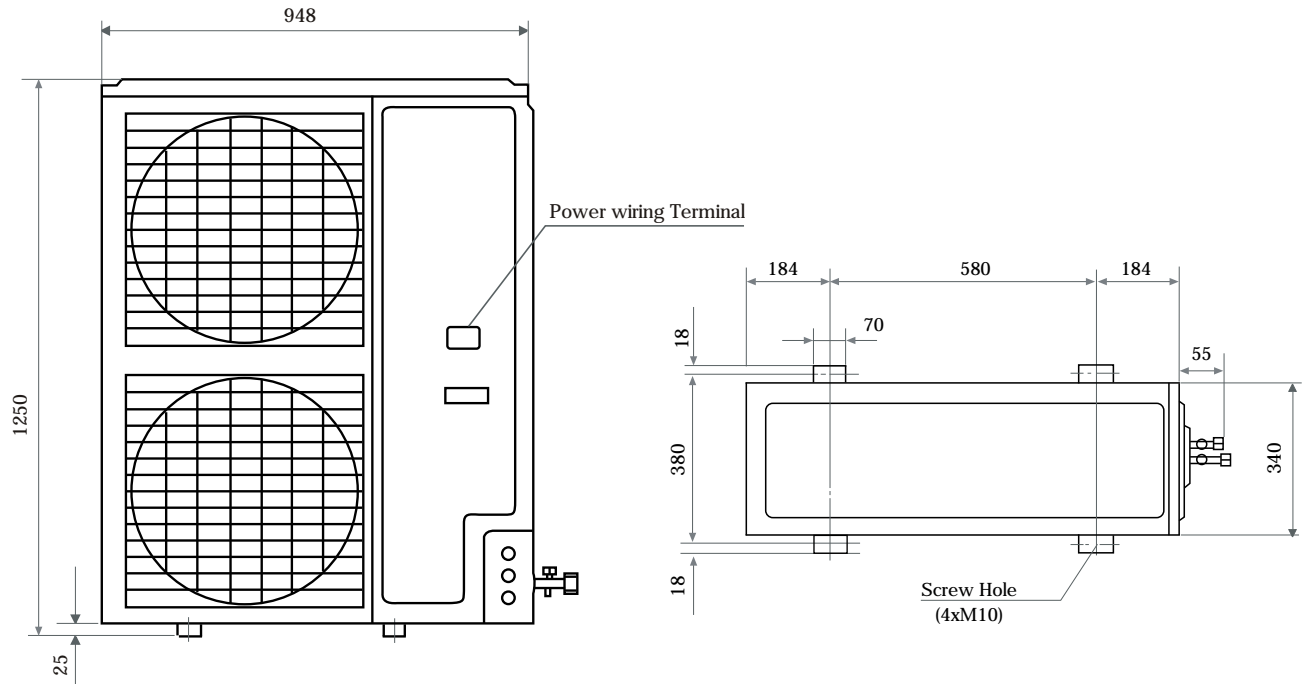

### 5. Installation Instructions

Please reference corresponding Operation & Installation Manua

#### Oil trap setting requirement:

Oil trap is required no mater the outdoor unit is upper or lower than indoor unit, only when the piping length is more than 10m.

Setting method: install one oil trap for every 10 meters at the gas pipe.

Trap dimensions:

Gas pipe diameter	Min. R (mm)	L (mm)
φ 15.88	40	80
φ 19.05	40	80
φ 25.4	40	80
φ 31.8	60	90
φ 38.1	60	100

**Note: the drop between the oil traps should be 10m.**

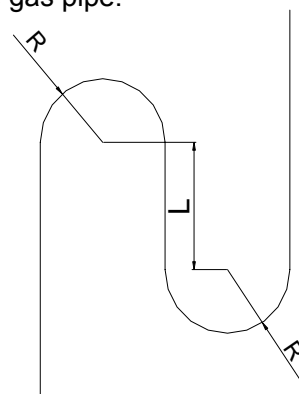

### 6. Parts and Functions

#### 6.1 Indoor unit

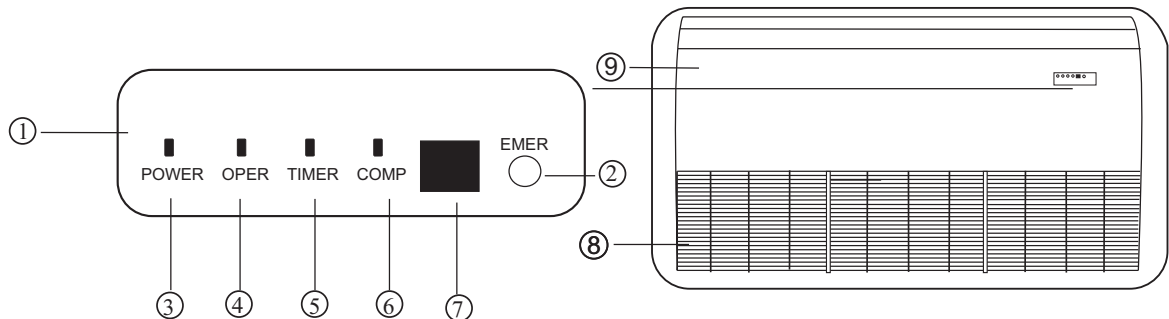

- ① Operating Control Panel
- ② Emergency switch
- ③ Power Indicator Lamp
- ④ OPERATION Indicator Lamp
- ⑤ TIMER Indicator Lamp
- ⑥ Compressor Lamp
- ⑦ Remote receiver
- ⑧ Inlet Grill ( Filter inside )
- ⑨ Front panel

#### 6.2 Outdoor unit

HCFU-42CH03

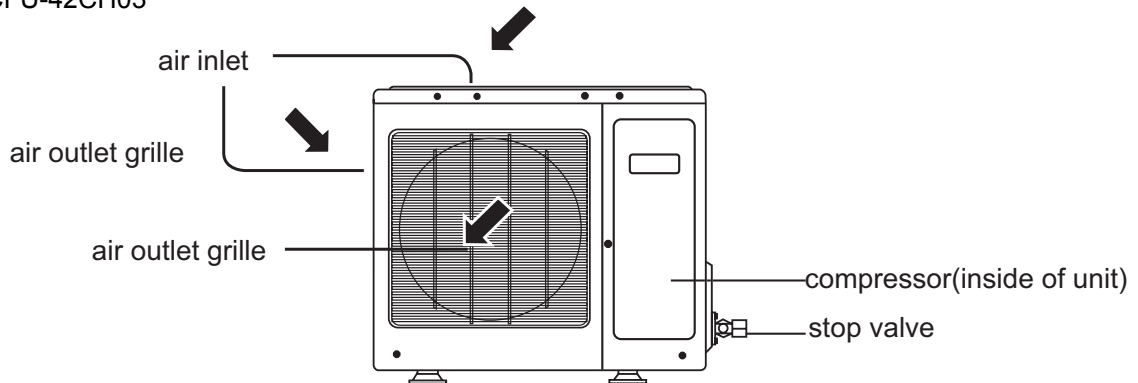

HCFU-42HK03

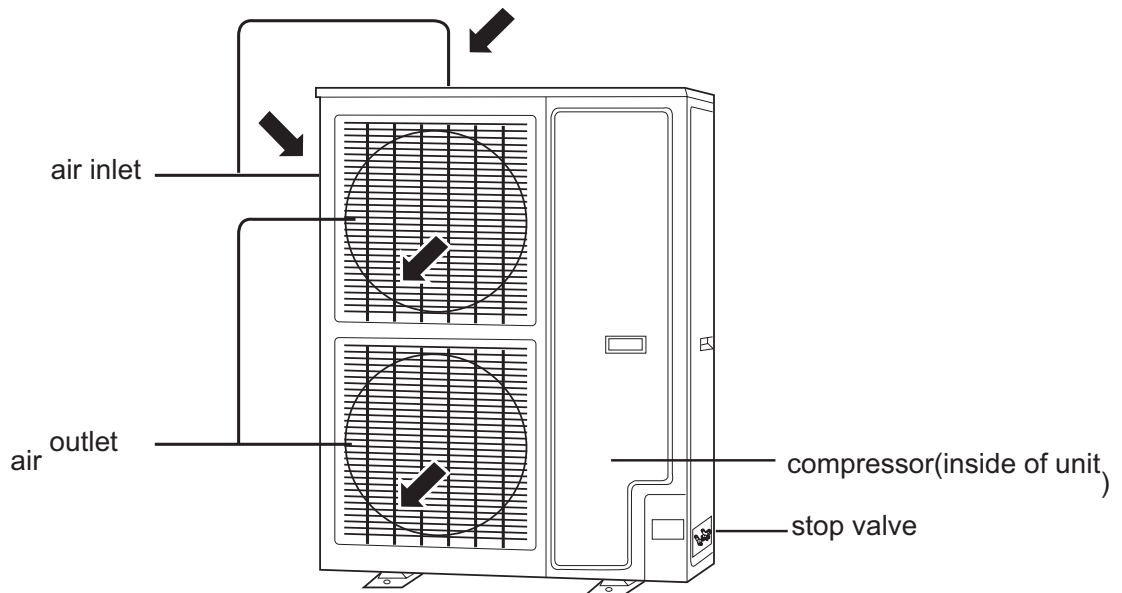

### 7. Controller functions

The convertible indoor unit can be controlled by wired controller YR-E12 or remote controller YR-H50.

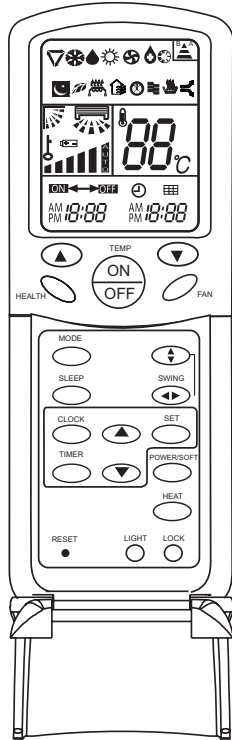

YR-H50



YR-E12

### 8. Refrigerant circuit

HCFU-42CH03

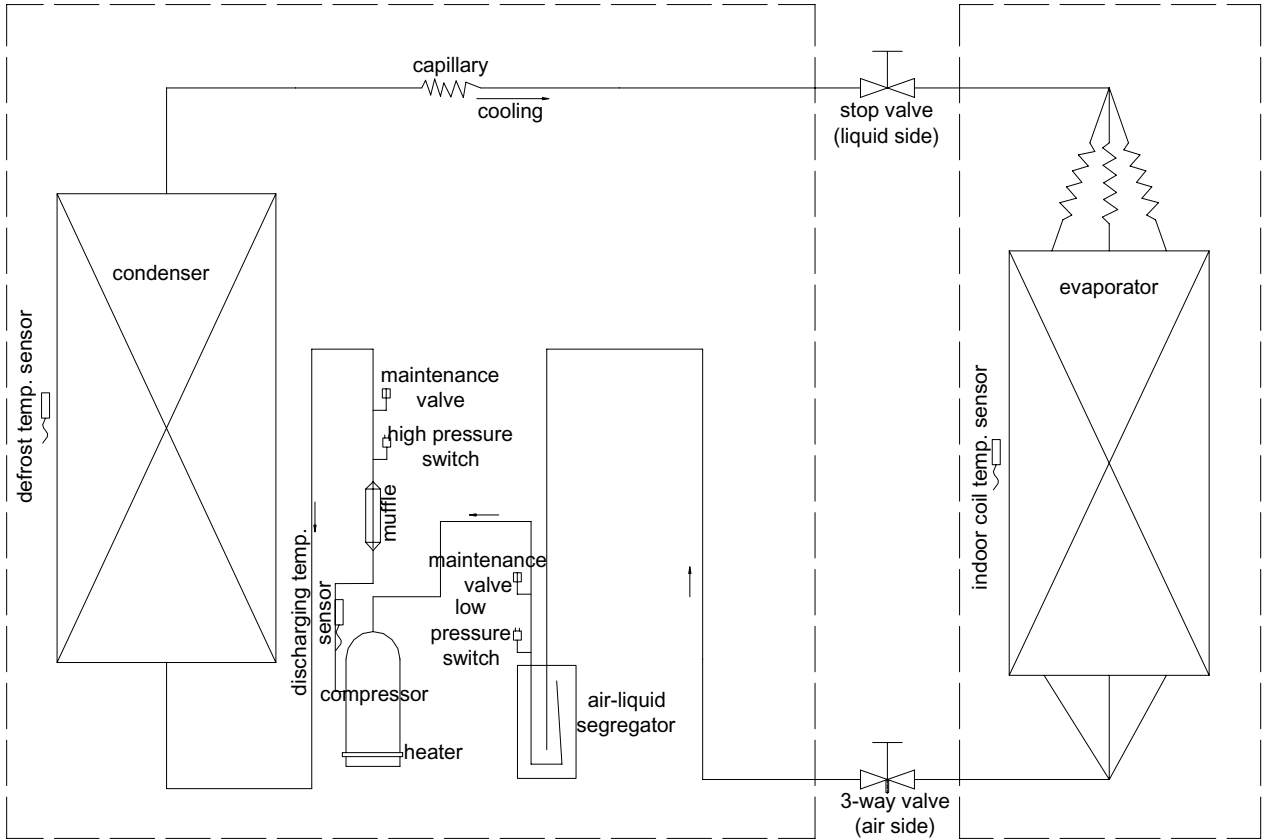

HCFU-42HK03

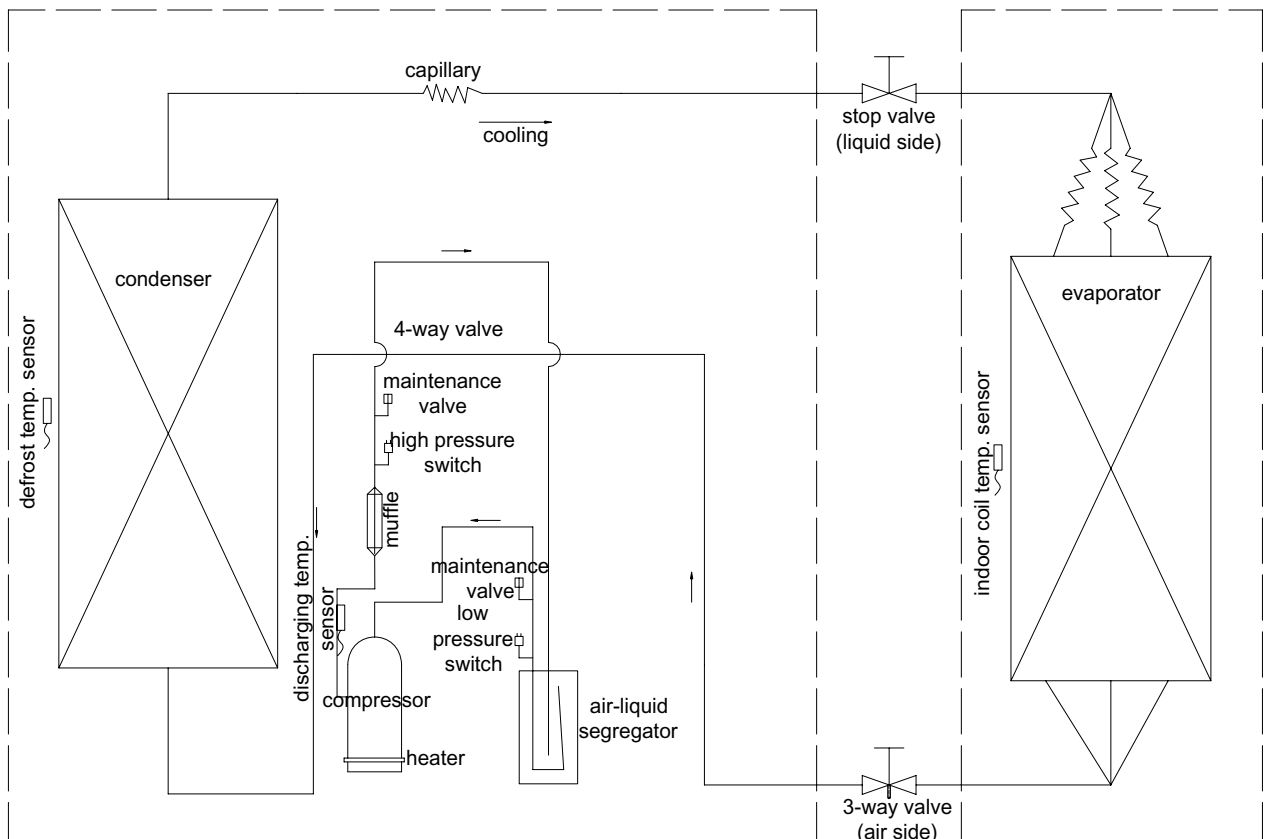

## 9. Electrical Control Functions

### 9.1 Outdoor control function

#### 1. Outdoor motor control

When the system does not occur overcooling, overheating, and over current protections, the outdoor motor will occur the below changes according to the outdoor ambient temperature and indoor coil temperature.

##### 1.1 General information

Outdoor motor is 2-speed type: high, low and stop.

The fan speed will change unless every step has been run for 45 seconds.

##### 1.2 Cooling mode

1.2.1 Indoor coil temp.  $\geq 15^{\circ}\text{C}$ , outdoor motor runs at high speed.

1.2.2 Indoor coil temp.  $< 5^{\circ}\text{C}$ , outdoor motor runs at low speed.

1.2.3  $5^{\circ}\text{C} \leq$  Indoor coil temp.  $< 15^{\circ}\text{C}$ , outdoor motor will change due to the outdoor ambient temp.

Outdoor ambient temp.  $> 28^{\circ}\text{C}$ , enter high speed; outdoor ambient temp.  $< 26^{\circ}\text{C}$ , enter high speed;  $26 \leq$  outdoor ambient temp.  $\leq 28^{\circ}\text{C}$ , keep the current speed.

In running, the system will be controlled as  $2^{\circ}\text{C}$  temperature tolerance; if outdoor ambient temp.  $< 26^{\circ}\text{C}$ , enter low speed; if outdoor ambient temp.  $> 28^{\circ}\text{C}$ , enter high speed.

##### 1.3 Heating mode (heat pump model)

1.3.1 Indoor coil temp.  $\geq 50^{\circ}\text{C}$ , outdoor motor will run at low speed.

1.3.2 Indoor coil temp.  $< 40^{\circ}\text{C}$ , outdoor motor will run at high speed.

1.3.3  $40^{\circ}\text{C} \leq$  indoor coil temp.  $< 50^{\circ}\text{C}$ , outdoor motor will change with outdoor ambient temp.

Outdoor ambient temp.  $< 13^{\circ}\text{C}$ , enter high speed; Outdoor ambient temp.  $> 15^{\circ}\text{C}$ , enter low speed;  $13 \leq$  Outdoor ambient temp.  $\leq 15^{\circ}\text{C}$ , keep the current speed;

In running, the system will be controlled as  $2^{\circ}\text{C}$  temperature tolerance; if outdoor ambient temp.  $< 13^{\circ}\text{C}$ , enter high speed; if outdoor ambient temp.  $> 15^{\circ}\text{C}$ , enter low speed.

Every step will run at least 45 seconds, and the motor will start up 2 seconds earlier than compressor.

#### 2. Defrost control

##### 2.1 Defrosting condition

In heating mode, the compressor will run for 30 minutes continuously or run for 45 minutes in all and for over 5 minutes contineously, outdoor motor at least runs for 2 minutes; If the outdoor ambient temperature and outdoor coil temperature can comply with the shadow area in the figure and keep for 1 minute.

##### 2.2 Quit condition

Outdoor coil temp. arrives the defrost-end temp.  $14^{\circ}\text{C}$  or the defrost time is over 12 minutes, the outdoor defrost will finish and send signal to indoor unit.

The min. defrost time is 2 minutes.

##### 2.3 Defrost operation

Compressor and outdoor motor stop, indoor motor stops meanwhile; 55 seconds later, the reversing valve will close. Another 5 seconds later, compressor starts up.

After defrost is over, compressor stops, outdoor motor runs at high speed; 55 seconds later, the reversing valve will open. Another 5 seconds later, compressor starts up and indoor motor runs at anti-code mode.

Type 1: Standard defrost

- 1) If  $Tr \geq -2^\circ\text{C}$ , when  $Tp \leq -6^\circ\text{C}$ , enter defrost.
- 2) If  $-12^\circ\text{C} \leq Tr < -2^\circ\text{C}$ , when  $Tp \leq -6^\circ\text{C}$ , enter drfrost as following fig.
- 3) No matter the ambient temperature, when  $Tp \leq -16^\circ\text{C}$ , enter defrost.

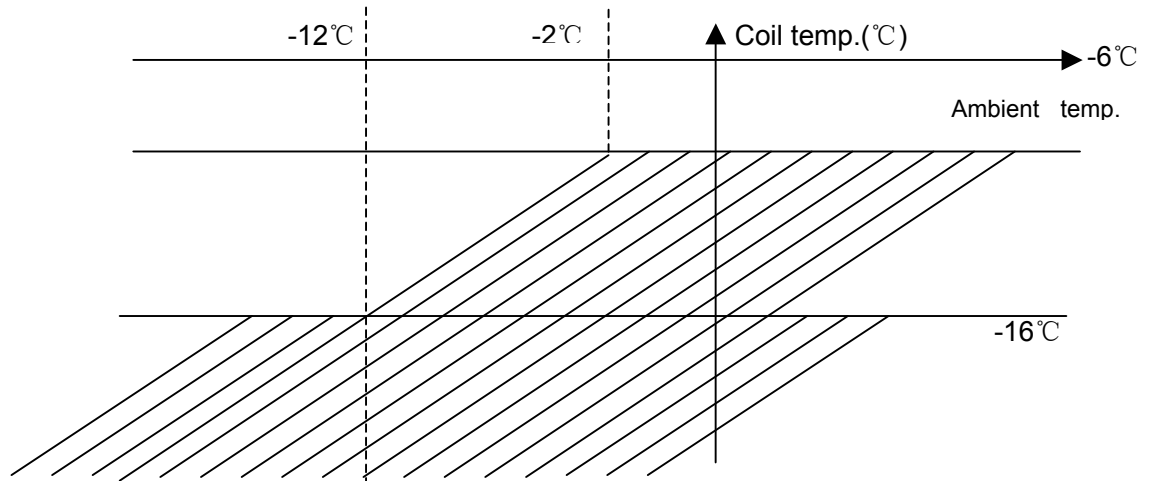

Type 2: Non-standard defrost (rectify defrost data by the device)

- 1) If  $Tr \geq 6^\circ\text{C}$ , when  $Tp \leq -6^\circ\text{C}$ , enter defrost.
- 2) If  $-18^\circ\text{C} \leq Tr < -6^\circ\text{C}$ , when  $Tp \leq -6^\circ\text{C}$ , enter drfrost as following fig.
- 3) No matter the ambient temperature, when  $Tp \leq -18^\circ\text{C}$ , enter defrost.

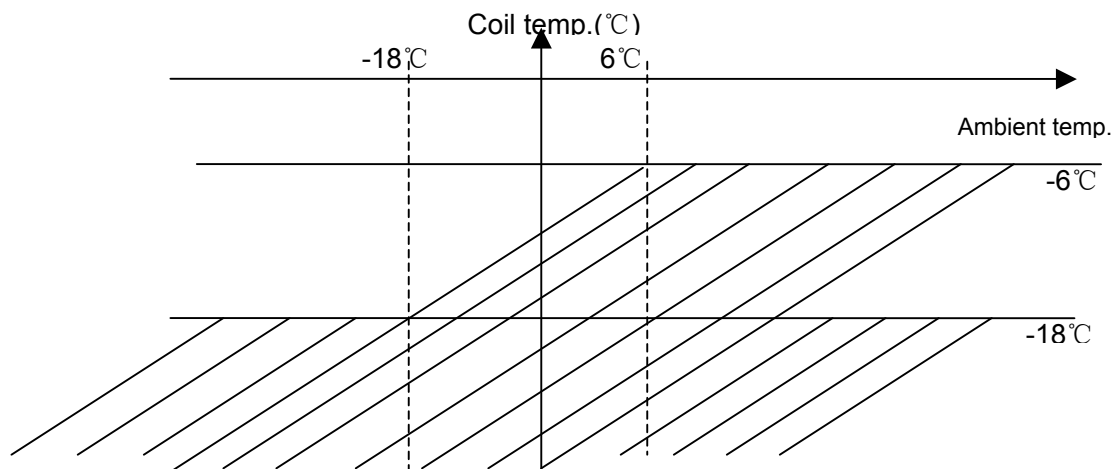

### 2.4 Manual defrost

Indoor sends defrost signal to outdoor, and the outdoor will receive the defrost signal when compressor is running in heating mode, then enter the defrost process. When outdoor coil temperature arrives the defrost-end point and the defrost time is over 5 minutes, outdoor will send the defrost-end signal to finish the defrost.

### 3. System protection function

The red lamp of outdoor PCB will light if it normal after electrify, the lamp will flash if failure occurs and indicate the failure code.

#### 3.1 Anti-freezed protection

When compressor has run for over 6 minutes, if indoor coil temp.  $Tg < 1^\circ\text{C}$  for over 1 minutes,



compressor and outdoor motor will stop and enter Fan mode. After compressor stops for 9 minutes, and indoor coil temp. rises up to 10°C, the unit resumes to cooling mode, compressor and outdoor motor will work again.

### 3.2 Overheat protection

In heating mode, if compressor is running and the indoor motor has run for over 30 seconds, if indoor coil temp.  $T_g > 56^\circ\text{C}$ , the outdoor motor will enter low speed; if  $T_g < 52^\circ\text{C}$  and outdoor motor has stopped for 45 seconds, outdoor motor will resume high speed; if  $T_g > 60^\circ\text{C}$ , outdoor motor will stop; if  $T_g < 56^\circ\text{C}$  and outdoor motor has stopped for 45 seconds, outdoor motor will resume work; if indoor coil temp.  $> 68^\circ\text{C}$ , compressor will stop and indoor motor run in thermostat OFF; if indoor coil temp. fall to  $48^\circ\text{C}$  and the compressor has stopped for 9 minutes, resume to heating mode, compressor and outdoor motor work again.

### 3.3 Over current protection(current and temp. protection are parallel available )

#### 3.3.1 In heating mode

After compressor running for 40 seconds, if the current thermostat has measured that system working current is more than 21A and keep it for 5 seconds, outdoor motor will convert into low speed; if working current is less than 18A, it will resume to high speed; if working current is more than 25A and keep it for 5 seconds, outdoor motor will stop; if working current is less than 22A, outdoor will resume to low speed (fan speed conversion frequency must be more than 45 seconds); after compressor running for 5 minutes, if working current is more than 34A and keep it for 5 seconds, compressor will stop and will resume 3 minutes later.

If within 30 minutes there are 3 times compressor over current protection, compressor will not start up, meanwhile, LCD will display E5. Only shut off and powered on again, the protection can be cancelled.

#### 3.3.2 Not in heating mode

After compressor running for 5 minutes, if working current is more than 34A and keep it for 5 seconds, compressor will stop and will resume 3 minutes later.

If within 30 minutes there are 3 times compressor over current protection, compressor will not start up, meanwhile, LCD will display E5. Only shut off and powered on again, the protection can be cancelled.

### 3.4 Power protection

PCB set power protection, detect the order of L2 and L3 by the combination of hardware and software, L1 and N as base-phase, L1, L2 and L3 as the correct phases. Short connect the compulsory cooling and electrify heating port last over 5 seconds, the 3-phase power detect will be cancelled.

Detect 3-phase immediately after been electrified, system will run after 10 seconds.

3.4.1 Detect no signal for over 5 seconds, indicate phase loss; resume normal if signal is resumed.

Detect the the phase is contrary for over 5 seconds, indicate phase failure; resume normal if signal is resumed.

3.4.2 The compressor will stop and 3-minute protection is realized if failure occurs.

The outdoor PCB will not run normally if power L1 and N lack or the position between N and L2, L3 wrong; the position of L1 and N wrong will indicate communication error E9.

### 3.5 High/Low pressure protection

#### 3.5.1 High pressure protection

There is no shield time for high pressure protection, the system will check the high pressure after compressor run, if the signal cut-off lasts more than 30 seconds, compressor and outdoor motor will stop and 3 minutes later it will resume. If within 30 minutes there are stop phenomenon 3 times because of pressure over high, the compressor will stop and LCD will display E6. only shut off and powered on again, the protection can be cancelled. Check the high pressure in standby and deforst mode, failure will be indicated if the signal cut-off lasts more than 30 seconds.

### 3.5.2 Low pressure protection

(1) Check the pressure switch immediately when compressor is start, the compressor will stop if signal cut-off lasts for 30 seconds, if cut-off 3 times continuously in 30 minutes, compressor will stop and alarm.

(2) In heating, low pressure switch will be shielded in 10 minutes after the compressor start.

(3) In defrosting, low pressure switch will not be checked. In 5 minute after defrost is over, check the low pressure switch. Check the low pressure switch during standby mode, the compressor will not start if low pressure switch activate during standby, compressor will stop and indicate low pressure failure if low pressure switch has activate for 30 seconds.

(4) Failure will occur if low pressure switch opens 3 times continuously in 30 seconds, failure can be resumable when power-off.

### 3.6 3-minutes protection for compressor

After compressor stops, it cannot be started until 3 minutes later. During the machine's running, if the time not more than 3 minutes after power is off, the compressor cannot be restarted until 3 minutes later after it is powered on again

### 3.7 Sensor broken down protection

#### a. Check if sensor breaks down

Outdoor board checks the sensor in short circuit or in open circuit or near to short/open circuit for 2 minutes continuously, then it will adjust the sensor broken down.

#### b. How to deal with it?

If the outdoor ambient temp. sensor, the outdoor coil temp. sensor and discharge temp. sensor have broken down, the unit will stop running, and alarm E3, E4, E4 simultaneously.

The discharge temp. sensor will check after compressor run, compressor will stop if temp. higher than 120°C after 2 minutes and 3 minutes later it will resume if temp. lower than 95°C. If within 30 minutes the discharge temp. over 120°C occurs 3 times, the compressor will stop and LCD will display E4. only shut off and powered on again, the system can be resumed. The compressor will stop and LCD will display E4 if check the signal short-connect over 2 minutes. After the compressor has started 3 minutes, detect the open-circute, The compressor will stop and LCD will display E4 if signal open 2 minutes continuously. Discharge temp. failure is resumable when given corrective signal. Outdoor ambient and coil temp. sensor can be used during motor control and deforst control.

### 3.8 Starting current control

Outdoor unit load control: after the outdoor motor running for 2 seconds, main compressor start up, the secondary compressor will run 2 seconds later.

### 3.9 4-way valve control

## 4. Outdoor PCB test

(1) There are three pins marked with TEST, please make the two ones near to COOL in short circuit. Outdoor begin to run in cooling mode, that is, compressor run and outdoor motor works at high

speed.

(2) There are three pins marked with TEST, please make the two ones near to HEAT in short circuit. Outdoor begin to run in heating mode, that is, compressor and 4-way valve run, outdoor motor works at low speed.

## 9.2 Indoor control function

### 1. General features

1.1 Control mode: remote or wired control + connecting port of long-distance control + passive port control.

1.2 Temperature control: 16-30°C ;

1.3 Precise of temperature control:  $\pm 1^\circ\text{C}$  ;

1.4 Indoor fan speed: AUTO, HIGH, MIDDLE, LOW (no AUTO when in FAN mode);

1.5 Swing control: the swing are controlled by the synchronous motor, main control board receive usable signal and set in swing mode or remain in other mode;

1.6 running mode: AUTO , COOL, DRY, FAN and HEAT;

1.7 Healthy function: 5VDC UV generator, 12VDC negative ion generator - high voltage collecting-dirt, 220VAC negative ion generator – oxygen pump;

1.8 Filter up-down control: adopt double-direction synchronous motor;

1.9 Auxiliary electric heating function: 12VDC control signal, 220VAC control signal or control switch;

1.10 Fresh air control: 12VDC DC motor, 220VAC AC control port output;

1.11 CLOCK setting, TIMER ON, OFF, ON/OFF and SLEEP function (only TIMER function is viable and temperature variety is unviable when running the SLEEP function in FAN mode);

1.12 Drain system function: Water level inspection and water pump control

1.13 Compulsory cooling operation;

1.14 Safety and protection devices: 3-minute protection for compressor startup, freeze protection device, overheat protection device, temperature cutoff protection, sensor failure, drainage, pressure, communication etc. protection.

1.15 Indoor ambient temperature, indoor and outdoor coil temperature inspection.

1.16 start current control: the outdoor fan start after compressor running 2s in normal situation.

### 2. LED function:

The LED for remote control type includes POWER, TIMER, COMPRESSOR, WATER PUMP; the POWER LED also indicate failure; when the unit is switched on by the controller, the POWER LED will be ON, when being switched off, the POWER LED will be OFF.; If the controller is in TIMER and SLEEP mode, the TIMER LED will be on; if it is not in TIMER and SLEEP mode, the TIMER LED will be off. When the compressor is running, the compressor LED will be on; when it stops, this LED will be off. POWER LED flashes when there are system failure, the flash times ti indicate the failure code.

### 3. Indoor AUTO FAN control

a) If the unit enters AUTO FAN for the first time, when  $\Delta T > 2$ , select high speed; when  $\Delta T \leq$

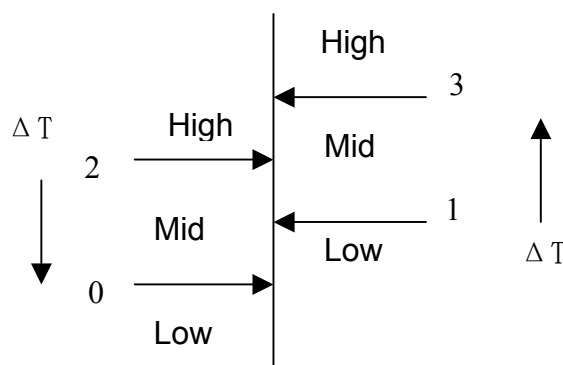

AUTO HIGH.

0, select low speed; or it will select med speed; when thermostat is OFF, fan will be low speed. (the conversion temperature difference is 1 degree).

b) If the present fan speed is AUTO HIGH, when  $\Delta T < 2$ , fan speed will change to AUTO MED.

c) If the present fan speed is AUTO MED, when  $\Delta T < 0$ , fan speed will change to AUTO LOW; when  $\Delta T > 3$ , fan speed will change to

- d) If the present fan speed is AUTO LOW, when  $\Delta T > 1$ , fan speed will change to AUTO MED.
- e) Fan speed conversion in AUTO FAN mode: the conversion will delay for 3 minutes from HIGH to LOW, and no delay from LOW to HIGH.
- f) When the fan speed is HIGH/LOW/MED, on the condition that the protection does not act, the unit will run at the set fan speed; when the protection acts, for the sake of the normal operation, the fan speed will be forced to conversion; in Dry mode, fan motor will be changed as request.

#### 4. AUTO mode control

4.1 When entering AUTO for the first time, the unit will select the running mode due to the below conditions, then perform the selected mode.

$T_r \geq T_s - 3^\circ\text{C}$  select COOL mode (includes FAN mode)

$T_r < T_s - 3^\circ\text{C}$  select HEAT or FAN mode

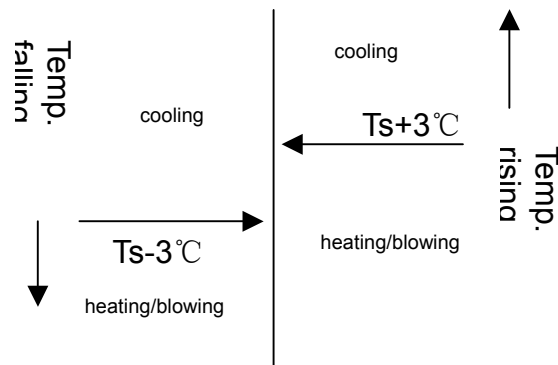

4.2 After entering the AUTO mode, the mode can change over among COOL, HEAT or FAN modes according to the indoor ambient temperature (conversion temperature difference is  $\pm 3^\circ\text{C}$ ).

4.3 If the unit is in COOL mode, when it arrives compressor-stop temperature, the compressor will stop; after compressor stops for 15 minutes, the unit will check the room temperature, if  $T_r < T_s - 3^\circ\text{C}$ , the unit will enter HEAT or FAN mode, or the unit will still be in COOL mode;

4.4 For the heat pump unit, if the unit is in HEAT mode at present, when it arrives compressor-stop temperature, the compressor will stop; after the compressor stops for 15 minutes, the unit will check the room temperature, if  $T_r > T_s + 3^\circ\text{C}$ , the unit will enter COOL mode, or it will still be in HEAT mode.

4.5 For cooling only unit, if the unit is at FAN mode, if  $T_r > T_s + 3^\circ\text{C}$ , the unit will enter COOL mode.

4.6 When the unit is in HEAT mode, if indoor heat exchanger temperature rises up to over  $63^\circ\text{C}$ , the unit will change into COOL mode. And within 1 hour, the heat exchanger temperature will not be limited, the heating operation will stop temporarily. 1 hour later, the unit will select the proper mode due to the above condition.

#### 5. COOL mode control

5.1 4-way valve being powered off, compressor run/stop will depends on the temperature difference between the room temperature and the set temperature.

5.2 In cooling mode, every time the compressor starts up, within 6 minutes, the compressor will not be limited by the temperature sensor, but the set temperature change, shutoff signal and protection action will not be limited by 6-minute protection, and the compressor can stop immediately.

5.3  $\Delta T \geq 1$  compressor will run;

$\Delta T \leq -1$  compressor will stop;

$-1 < \Delta T < 1$  compressor will stay in original state

5.4 Anti-freed protection (invalid in compulsory operation, trial running, heating mode)

When the unit has run for over 6 minutes after compressor starts up, if indoor coil temperature  $T_g < 1^\circ\text{C}$ , the compressor and the outdoor motor will stop, and the unit will change to FAN mode; 9 minutes later after compressor stops and when indoor coil temperature rises to  $10^\circ\text{C}$ , the unit will resume to COOL mode, the compressor and the outdoor motor will run again.

5.5 Outdoor fan control: (realized by outdoor when with outdoor communication function)

if the temp. of indoor coil sensor  $T_g < 6^\circ\text{C}$ , control the outdoor fan by the temp. of outdoor coil sensor;

if the temp. of outdoor defrost sensor  $T_c < 34^\circ\text{C}$ , the outdoor fan will be OFF and lasted 45s at least;

if the temp. of outdoor defrost sensor  $T_c > 44^\circ\text{C}$ , the outdoor fan will be ON;

if the temp. of outdoor defrost sensor  $34^\circ\text{C} \leq T_c \leq 44^\circ\text{C}$ , the outdoor fan will remain in the original state.

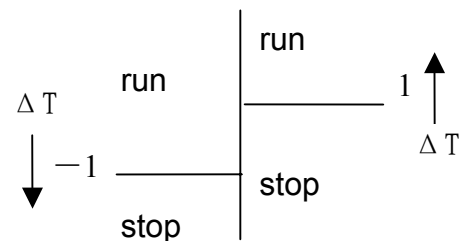

### 5.6 Temperature cutoff protection

In cooling mode, the unit will check indoor coil temperature every time the compressor has run for 1 minutes, when indoor coil temperature  $T_g > T_r + 5$ , the unit will stop and 3 minutes later restart up; if the temperature cutoff occurs for 3 times continuously, the unit will stop and alarm.

### 6. DRY mode control

6.1 When the unit enters DRY mode for the first time, the compressor, outdoor motor and indoor motor will perform according to the below conditions:

$\Delta T > 2$ , the compressor and the outdoor motor will run continuously, indoor motor will run at the set speed, this area is defined as Area A;

$0 \leq \Delta T \leq 2$ , the compressor and the outdoor motor will always run for 10 minutes and then stop for 6 minutes, indoor motor will be LOW speed, this area is defined as Area B;

$\Delta T < 0$ , the compressor and the outdoor motor will stop, indoor motor will run at Low speed, this area is defined as Area C.

6.2 After the unit is running in DRY mode, the system will change over among Area A, Area B, and Area C (the conversion temperature difference  $\pm 1^\circ\text{C}$ )

If the system is in Area A, when  $\Delta T < 1$ , change to Area B;

If the system is in Area C, when  $\Delta T > 1$ , change to Area B;

If the system is in Area B, when  $\Delta T > 3$ , change to Area A;

When  $\Delta T < -1$ , change to Area C.

6.3 Anti-freezed protection (invalid in compulsory operation, trial running, heating mode)

When the unit has run for over 6 minutes after compressor starts up, if indoor coil temperature  $T_g < 1^\circ\text{C}$ , the compressor and the outdoor motor will stop, and the unit will change to FAN mode; 9 minutes later after compressor stops and when indoor coil temperature rises to  $10^\circ\text{C}$ , the unit will resume to COOL mode, the compressor and the outdoor motor will run again.

6.4 Outdoor fan control: (realized by outdoor when with outdoor communication function)

if the temp. of indoor coil sensor  $T_g < 6^\circ\text{C}$ , control the outdoor fan by the temp. of outdoor coil sensor;

if the temp. of outdoor defrost sensor  $T_c < 34^\circ\text{C}$ , the outdoor fan will be OFF and lasted 45s at least;

if the temp. of outdoor defrost sensor  $T_c > 44^\circ\text{C}$ , the outdoor fan will be ON;

if the temp. of outdoor defrost sensor  $34^\circ\text{C} \leq T_c \leq 44^\circ\text{C}$ , the outdoor fan will remain in the original state.

### 6.5 Temperature cutoff protection

In cooling mode, the unit will check indoor coil temperature every time the compressor has run for 1 minutes, when indoor coil temperature  $T_g > T_r + 5$ , the unit will stop and 3 minutes later restart up; if the temperature cutoff occurs for 3 times continuously, the unit will stop and alarm.

### 7. HEAT mode control

7.1 4-way valve control: in heating mode, compressor startup---4-way valve being electrified 10 seconds ahead; compressor running---4-way valve retains original state; compressor shutoff---4-way valve being powered off 2 minutes and 50 seconds later (except for defrosting, 4-way valve being electrified 5 seconds ahead, and being powered off 55 seconds later).

7.2 In heating mode, for everytime the compressor startup (thermostat ON), within 6 minutes, the 4-way valve will not be limited by the temperature sensor, but for the set temperature change, shutoff signal and the protection, the compressor can stop immediately without 6-minute limitation.

7.3  $\Delta T \geq 1$  compressor running, indoor motor runs at anti-cold air mode;

$\Delta T \leq -1$  compressor stops, indoor motor runs at blowing remaining heat mode;

$-1 < \Delta T < 1$  compressor retains original state

7.4 Overheat protection (for the unit with outdoor PCB, the outdoor motor is controlled by outdoor unit, but the compressor is still controlled by indoor unit, and their temperature points will not be accordant completely)

In heating mode, compressor has started up and indoor motor has run for over 30 seconds, if indoor coil temperature  $T_g > 60^\circ\text{C}$ , outdoor motor will stop; if  $T_g < 56^\circ\text{C}$ , and outdoor motor has stop for

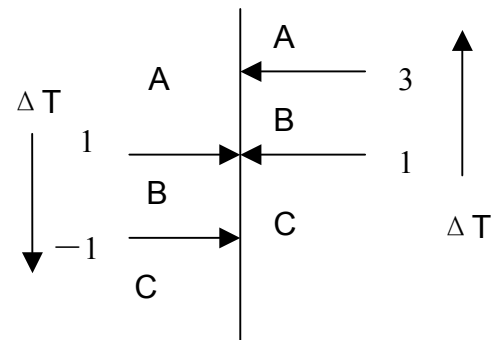

45s, outdoor motor will run again; if  $T_g > 73^\circ\text{C}$ , the compressor will stop and indoor motor will run according to the thermostat state. After the compressor stops for 3 minutes and  $T_g$  reduces to  $48^\circ\text{C}$ , the unit will resume to heating mode, and the compressor and the outdoor motor will run again.

#### 7.5 Temperature cutoff protection

In heating mode (besides the defrosting), the unit will check indoor coil temperature every time the compressor has run for 1 minutes, when indoor coil temperature  $T_g < T_r - 5$ , the unit will stop and 3 minutes later restart up; if the temperature cutoff occurs for 3 times continuously, the unit will stop and alarm.

#### 7.6 Anti-cold air function in heating mode

After entering heating mode, or last defrosting is over, the compressor will start up, if  $T_g < 28^\circ\text{C}$ , indoor motor will stop; if  $38^\circ\text{C} > T_g \geq 28^\circ\text{C}$ , indoor motor will run at low speed; if  $T_g \geq 38^\circ\text{C}$  or the compressor has run for over 4 minutes, indoor motor will run at the set speed; once the motor has started up, it will not stop because of  $T_g$  reduction.

#### 7.7 Blowing remaining heat function

In heating mode, the thermostat is OFF, the compressor stops, indoor motor will run at low speed until  $T_g < 28^\circ\text{C}$  and has run for 50 seconds at least.

Note: in heating mode, "the compressor stops---indoor motor delays to stop" adjust if the pipe blows remaining heat; "the compressor startup---indoor motor delays to start up" adjust if the pipe is anti-cold air; in other conditions, the compressor and the indoor motor are allowable not to be in company. In cooling mode, the motor will run according to the control, not together with the compressor.

#### 7.8 Defrosting function in heating mode

In defrosting and when the compressor resumes to run for 3 minutes after defrosting is over, the unit will not adjust the sensor failure.

7.8.1 Manual defrost: In heating mode, the set temperature  $30^\circ\text{C}$  and in high speed, in 5 seconds, press SLEEP button 6 times continuously, then the buzzer will sound 3 times, you can enter the manual defrosting. At this moment, the unit will not adjust the enter condition of defrost and begin to defrost function directly, whose procedure is as the same as the auto defrost; the quit condition is that the defrosting time is up to 5 minutes.

7.8.2 Auto defrost enter condition: a) the compressor has run for 45 minutes continuously or for 75 minutes in all and has run for over 10 minutes continuously. b) the compressor and outdoor fan running normally. c) the temp. of indoor coil sensor lower than  $45^\circ\text{C}$ , d) the defrosting temp. lower than  $-8^\circ\text{C}$  (use the defrosting start signal from outdoor in the condition of with outdoor communication ).

7.8.3 Auto defrost quit condition: The defrosting temp. over  $14^\circ\text{C}$  or the defrosting time is over 12 minutes (use the defrosting end signal from outdoor in the condition of with outdoor communication )

7.8.4 Defrost process : a) enter defrosting mode, the compressor, outdoor and indoor fan motor stops; b) 55 seconds later, 4-way valve will be reverse, after more 5 seconds, compressor begins to run; c) defrosting is over, compressor stops, outdoor fan running at high speed; d) 55 seconds later, 4-way valve runs and compressor starts up. The indoor fan motor will run at anti-cold air condition.

#### 7.8.5 For the unit with auxiliary electric heating function:

- If the auxiliary electric heating function is working when the defrosting condition is met, please stop electric heater firstly, 20 seconds later, defrosting can begin;
- After defrosting, the unit will adjust the working state of electric heater according to the setting before defrosting.

#### 7.9 Auxiliary electric heating function (valid in heating mode or heating state in AUTO mode)

Enter condition: 1)  $\Delta T > 1$ ; 2) Thermostat ON and running for 1 minute; 3)  $T_r < 26^\circ\text{C}$ ; 4) Indoor motor running; 5) Electric heating function start signal available (cancelled); 6) The system working in heating mode or in heating state of AUTO mode; 7)  $T_g < 48^\circ\text{C}$

If the above conditions can all be met, the electric heating function will work.

Quit condition: 1)  $\Delta T \leq 1$ ; 2) Thermostat OFF; 3)  $T_r > 26^\circ\text{C}$ ; 4) Indoor motor stops; 5) Electric heating function start signal not available (cancelled); 6) The system in non-heating operation; 7)  $T_g > 52^\circ\text{C}$

If one of the above conditions can be met, the electric heater will stop.

## 8. FAN mode control

The compressor and the outdoor motor will stop running, indoor motor can be set at high/med/low speed, the fan blade can swing or stay at one position. In this mode, you can set the TIMER and SLEEP function.

## 9. CLOCK setting and TIMER function

The unit can set 24-hour TIMER ON/OFF, and the min. unit is 1 minute, after being set, the timer lamp of indoor will be on, and after the timer is over, the timer lamp will be off.

TIMER ON: RUN LED is off, compressor LED is off, and TIMER LED is on, the unit is in stop state. When timer is over, the unit begins to run, and the timer LED is off. The unit operation begins from receiving the timer signal for the last time. The SLEEP function only can be set before the TIMER ON begins.

TIMER OFF: the unit running, the timer LED on, while the timer is over, timer LED off, the unit will stop, the sleep can be set, the sleep time will replace the original time of TIMER ON/OFF.

TIMER ON/OFF set at the same time: when the timer on/off is set, the timer LED will be off; the SLEEP function can be set, the sleep time will replace the original time of TIMER ON/OFF.

## 10 SLEEP function (energy saving function at night)

10.1 Standard sleep function: in cooling or dry mode, after running at SLEEP mode for 1 hour, the set temperature will rise 1°C, another 1 hour later, the set temperature will rise another 1°C; the unit continues running for 6 hours, then the unit will stop.

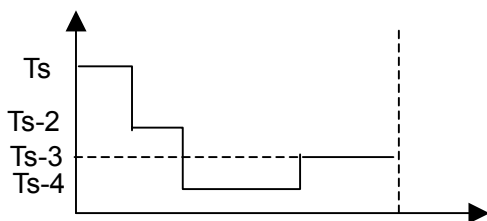
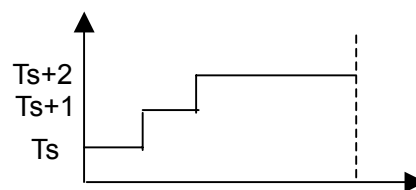

10.2 Standard sleep function: in heating mode, after running at SLEEP mode for 1 hour, the set temperature reduces 2°C, another 1 hour later, the set temperature will reduce 2°C, and another 3 hours later, the set temperature rises 1°C; the unit continues running for 3 hours, then the unit will stop.

10.3 Non-standard SLEEP function: the sleep function

can realize 1~8 hours sleep mode when being combined with the TIMER function.

- 1) When in Auto mode, the unit will make SLEEP operation due to the setting.
- 2) After setting SLEEP function, the clock can not be adjusted.
- 3) If sleep time is no more than 8 hours, when the time arrives, the unit will shut off.
- 4) If sleep function is set after setting TIMER OFF function, the unit will execute as the SLEEP function.
- 5) If SLEEP function is set, the TIMER function can not be set.
- 6) If sleep function is set after setting TIMER ON function, the sleep function only can be set before the TIMER ON time arrives.
- 7) After setting sleep function, press CLOCK button to check the clock; press TEMP button to display the set temperature, and press again to change the set temperature.

## 11 Water level inspection and water pump control

- 1) In COOL (including cooling state of AUTO mode and the compulsory cooling) and DRY mode, as long as the compressor runs, water pump will work; and once the compressor stops, water pump will stop 5 minutes later;
- 2) In standby state of cooling mode, heating mode and fan mode (including auto fan mode), after water tank is full, the float switch will disconnect, if the controller detects this signal for 2 seconds, the water pump will begin to work. After the float resets, water pump will continue working and stops 5 minutes later;
- 3) If the water-full signal is detected for over 5 minutes, the compressor will stop; water pump will work for 5 minutes and stop for 5 minutes, then repeat as a cycle, until the float resets, the water pump will stop 5 minutes later; if water pump has repeated for 4 cycles, the float can not reset, and the unit will alarm water drainage abnormal. And the water pump will continue the cycle.

## 12. System protection

### 12.1 3-minute protection for compressor startup

After the compressor stops, at least 3 minutes later, the compressor can restart up; the compressor can restart up. Being electrified for the first time, there is 3-minute delay protection.

## 12.2 Time shorting function

If the time shorting port is in short circuit, the unit will perform a 1/60 time shorting control.

## 12.3 High pressure protection

After compressor is running for 3 minutes, the unit will check the pipe pressure, when the pipe pressure is too high, 30 seconds later, compressor and outdoor fan motor will stop, and then 3 minutes later, the unit will be normal. Within 30 minutes, if the compressor stops and will send failure because of too high pressure for 3 times.

## 12.4 Low pressure protection

After compressor is running for 3 minutes, the unit will check the pipe pressure, when the pipe pressure is too low and low pressure switch is running for 30 seconds, compressor and outdoor fan motor will stop and will send failure

## 13. Trouble code

The remote receiver, wired controller and indoor PCB indicator all can indicate the failure code.

Remote control indoor PCB flash times	Wired controller display	Central controller display	Fault description	Possible cause	Remedy
10	08(08H)	21D	Fault in drain system	Float switch is open 25m or longer	due to the signal, resumable
1	01(01H)	01D	Indoor ambient temp. sensor failure	sensor broken down or short circuit for more than 2m continuously	due to the signal, resumable
2	02(02H)	02D	Indoor pipe temp. sensor failure	sensor broken down or short circuit for more than 2m continuously	due to the signal, resumable
3	74(4AH)	11D	Outdoor ambient temp. sensor failure	sensor broken down or short circuit for more than 2m continuously	due to the signal, resumable
4	73(49H)	12D	Outdoor pipe temp. sensor failure	sensor broken down or short circuit for more than 2m continuously	due to the signal, resumable
5	72(48H)	10D	Overcurrent	Detector CT current is above the limit 3 times within 30m.	Need to be checked, reset
6	83(53H)	14D	High pressure malfunction	High pressure switch acts for 3 times in 30m	Need to be checked, reset
7	71(47H)	22D	Power failure	Wrong phase, phase failure or loss	Need to be checked, reset
8	07(07H)	06D	Communication failure between wired controller and indoor unit	communication abnormal for more than 4m continuously	due to the signal, resumable
9	06(06H)	05D	Communication failure between indoor and outdoor units	communication abnormal for more than 4m continuously	due to the signal, resumable
11	11(0BH)	30D	External alarm signal input	External alarm is cut out for 10s or longer	due to the signal, resumable
12	03(03H)	20D	Fault in coil/suction line temp. sensor	sensor broken down or short circuit for more than 2m continuously	due to the signal, resumable
13	13(0DH)	31D	Temperature shut-off	Directional valve malfunction repeats 3 times	Need to be checked, reset
14	76(4CH)	15D	Fault in discharging temp. sensor	sensor broken down or short circuit for more than 2m continuously	due to the signal, resumable
15	05(05H)	17D	EEPROM error	EEPROM data loss	Default operation
16	84(54H)	26D	Low pressure malfunction	low pressure switch is activated	Need to be checked, reset



17	80(50H)	15D	Compressor overheat	Detected temperature of discharge line is higher than 120°C	Resrorable when lower than 100°C
18	12(0CH )	23D	Fault in operation mode	Indoor units operate in different modes	Resrorable in same operation mode
19	75(4BH)	18D	Outdoor coil B(suction sensor-multi)	sensor broken down or short circuit for more than 2m continuously	due to the signal, resumable
20	77(4DH )	15D	Outdoor discharge B (oil temp. sensor-multi)	sensor broken down or short circuit for more than 2m continuously	due to the signal, resumable
21	20(32D)	07D	Module failure	Module overheat, overcurrent, short-circuit	due to the signal, resumable
22	36(54D)	08D	Fault in zero-load	Current sensor failure or compressor is not started	due to the signal, resumable

**14 Jumper selection** (√ shows jumper connected, ON; × shows jumper disconnected, OFF; \* shows no limitation)

	J1	J2	J3	J4
Wired control/ infrared control	√/×	*	*	*
Temp. compensation available/not available	*	√/×	*	*
With/no outdoor PCB	*	*	√/×	*
Cooling only/heat pump	*	*	*	√/×
			J5	J6
Time shorting switch	√/×	*	*	*
Forced or not	*	√/×	*	*
Ornarment or not	*	*	×/√	*
Oxygen or not	*	*	*	×/√
	J7	J8	J9	J10
Other/2P convertible	√/×	*	*	*
single split/ multi split	*	√/×	*	*
Indoor unit address 0/other	*	*	√/×	*
2P convertible /single blade	*	*	*	√/×

**15. Network address selection** (√ shows jumper connected, ON; × shows jumper disconnected, OFF)

address	SW1				SW2				4
	1	2	3	4	1	2	3		
1	×	×	×	×	×	×	×	× shows passive port control AND	
2	√	×	×	×	×	×	×		
3	×	√	×	×	×	×	×		
4	√	√	×	×	×	×	×		
5	×	×	√	×	×	×	×	√ shows passive port control – the later entering in priority	
6	√	×	√	×	×	×	×		
.....	.....	.....	.....	.....	.....	.....	.....		
126	√	×	√	√	√	√	√		
127	×	√	√	√	√	√	√		
128	√	√	√	√	√	√	√		

### 10. Electrical data

#### 10.1 Outdoor unit wiring diagram and PCB photo

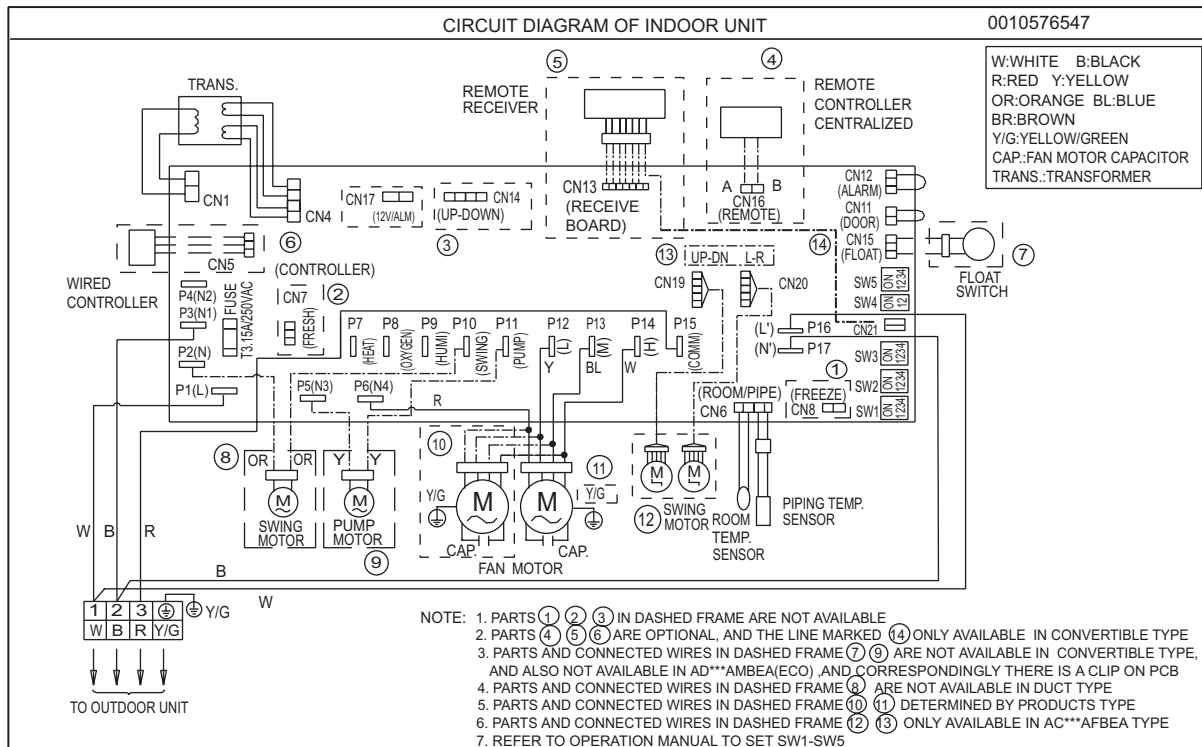
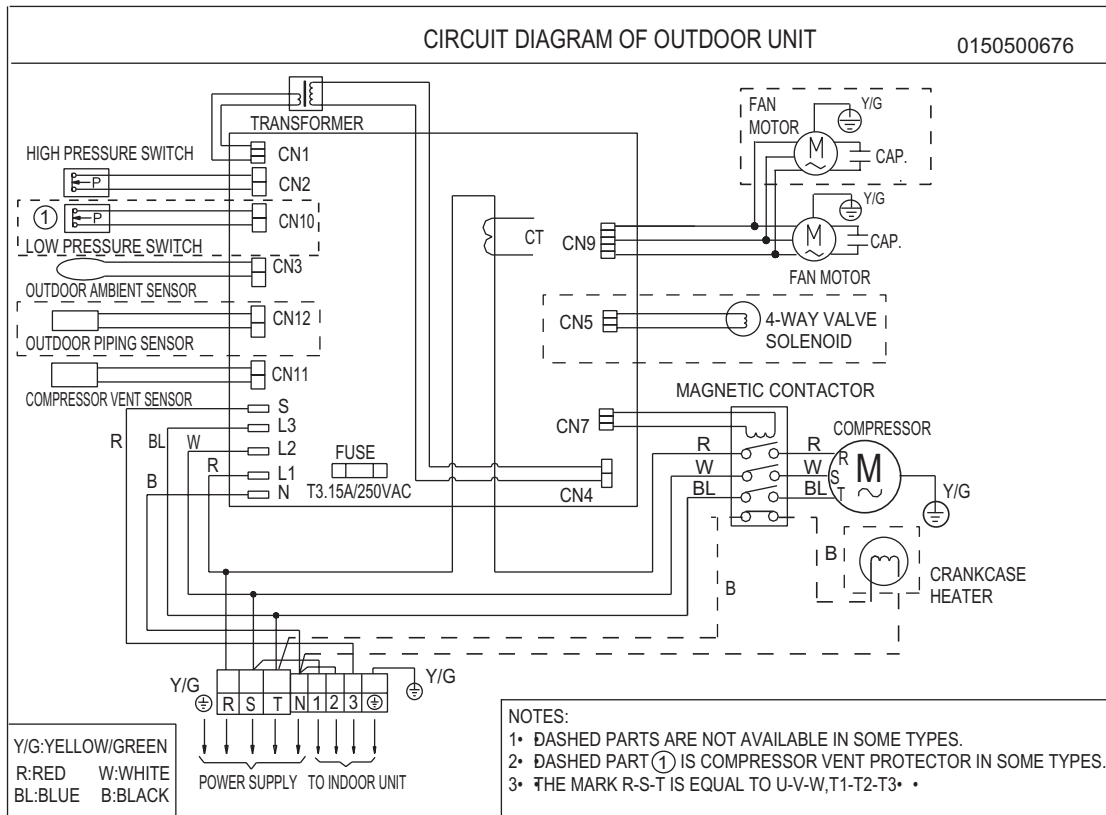

### 10.2 HCFU-42HK03 outdoor PCB 0010452441 photo

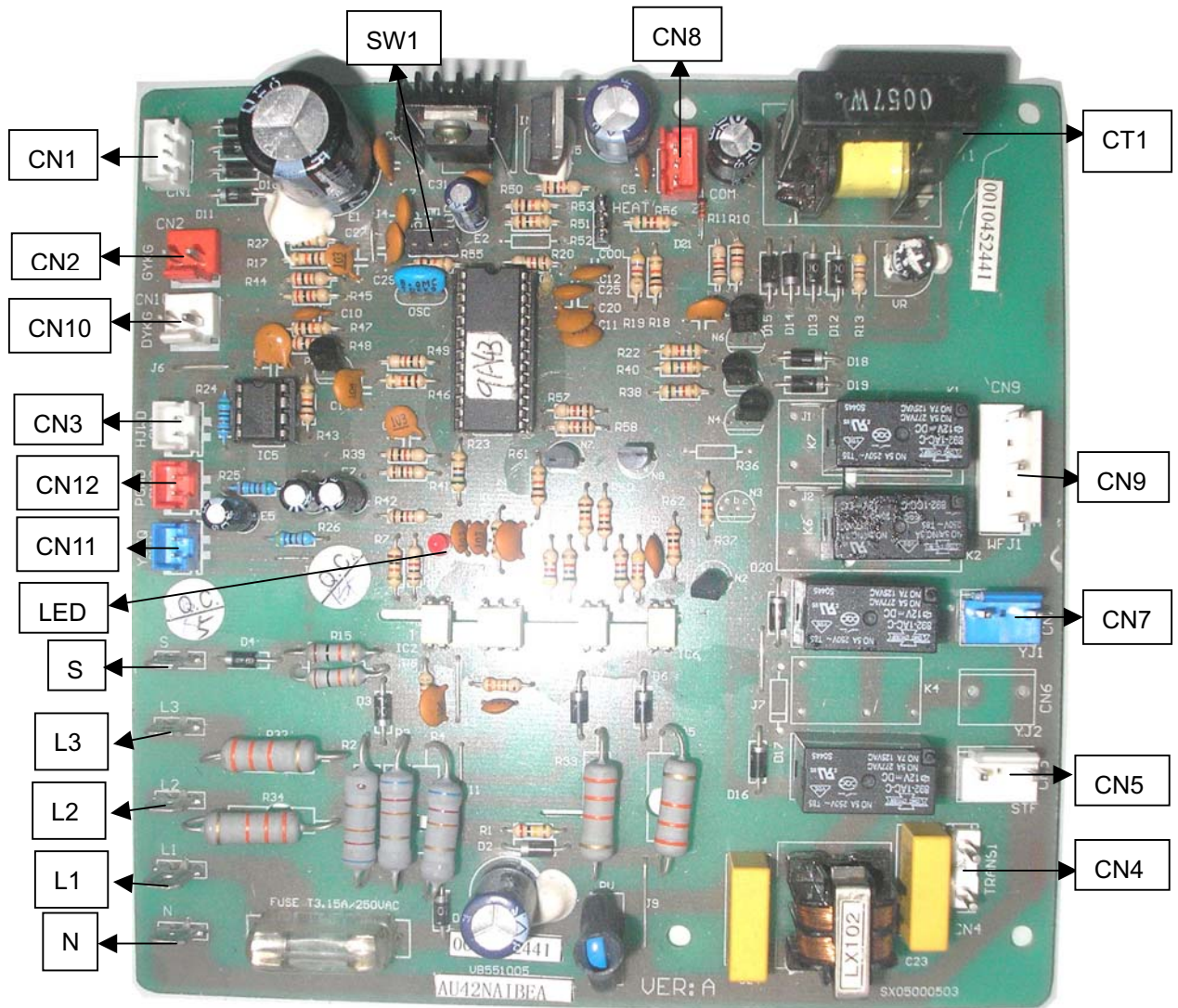

### 10.3 HCFU-42CH03 outdoor PCB 0010451429 photo

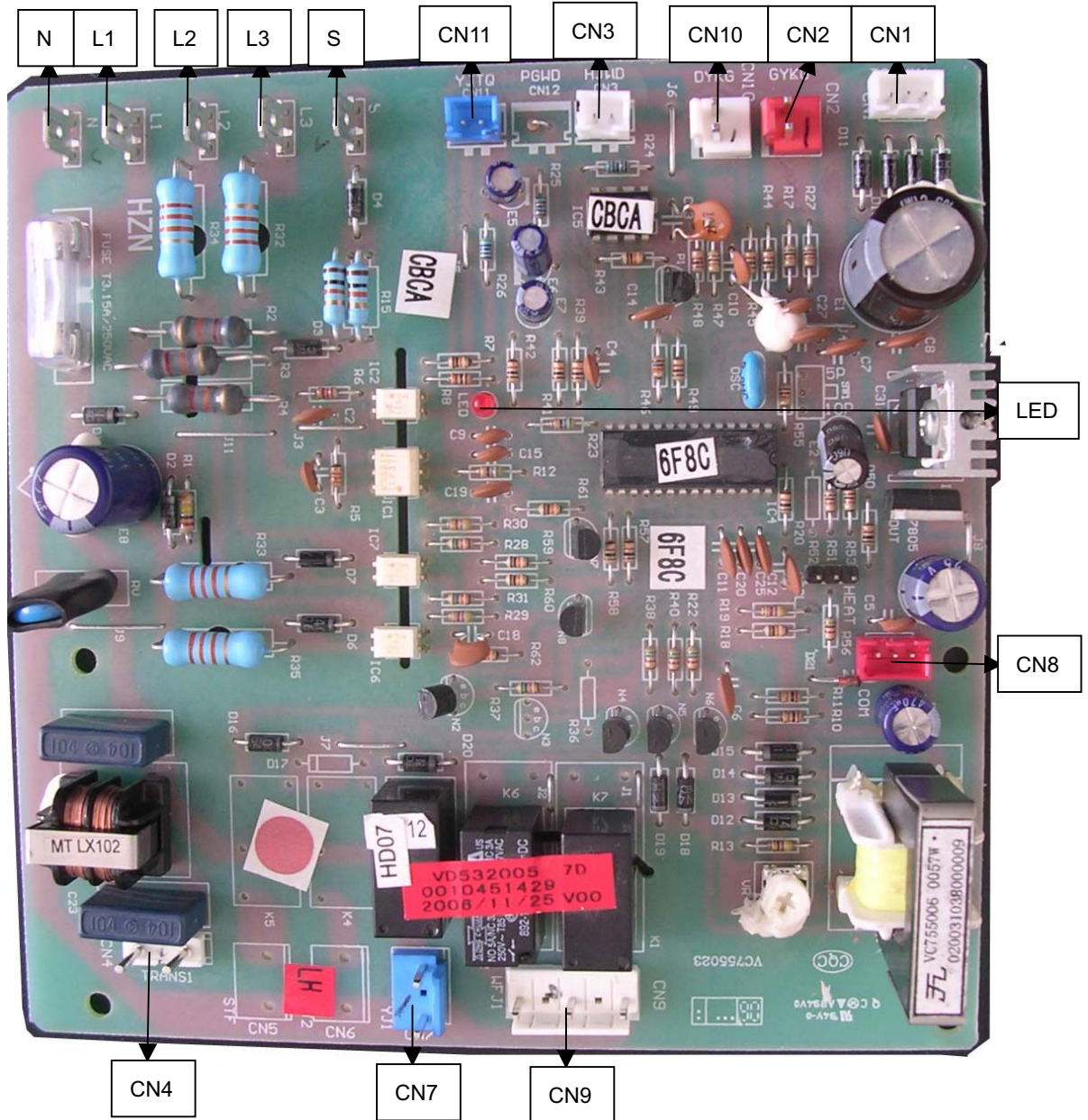

### 10.4 Indoor PCB 0010451167E photo

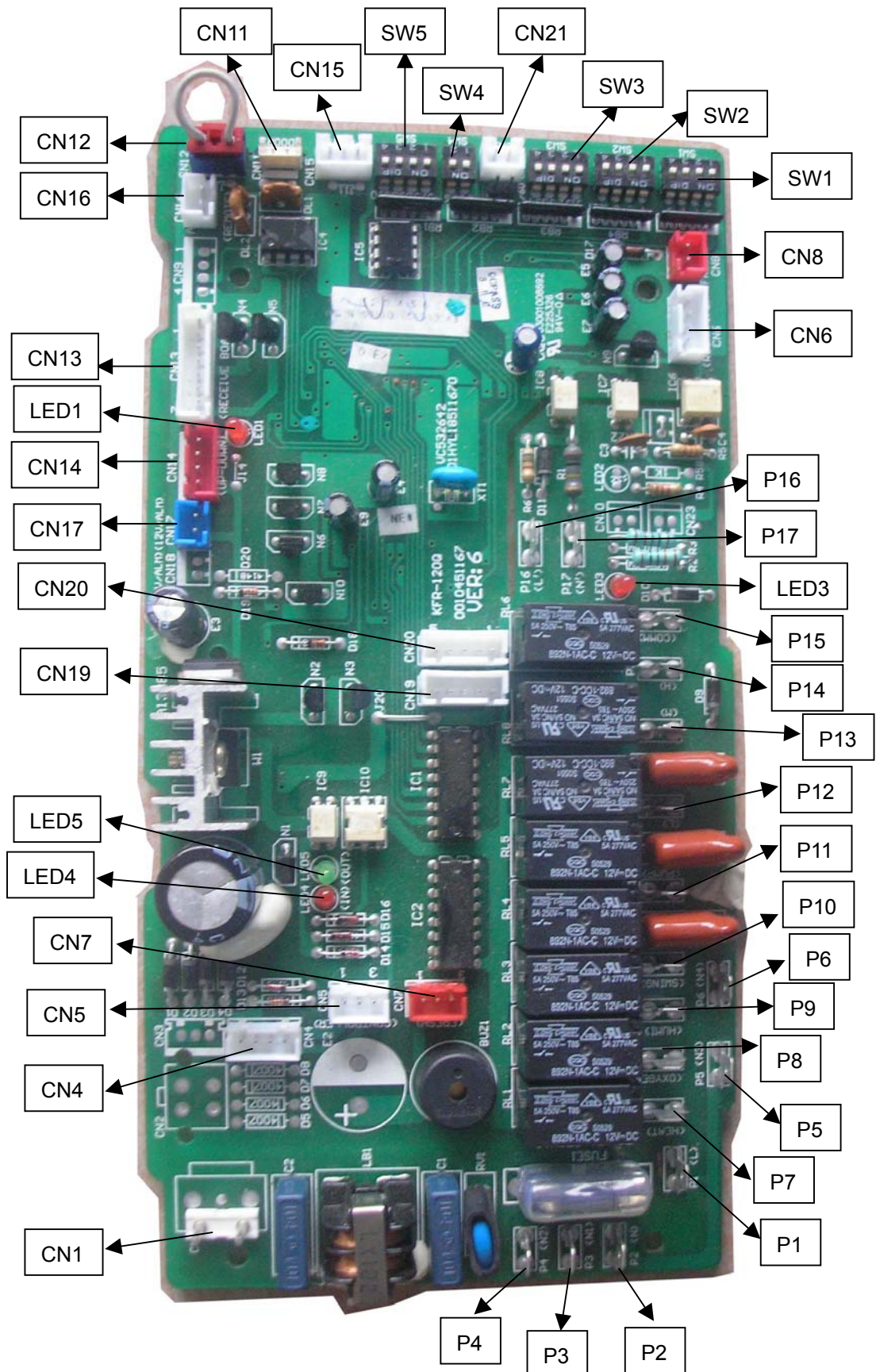

**Condition for the PCB data:**

1. Working ambient temperature:  $-10^{\circ}\text{C} \sim 70^{\circ}\text{C}$ , relative humidity: 30% ~ 95%
2. Preserved ambient temperature:  $-20^{\circ}\text{C} \sim 80^{\circ}\text{C}$ , relative humidity: 30% ~ 95%
3. Power supply: 220VAC, 50/60Hz, voltage range: 160V ~ 250V
4. Precise of temperature control:  $\pm 1^{\circ}\text{C}$

**0010451167E PCB information – port and definition**

- P1—connect to external power supply, live line: L (220VAC)  
P2—connect to external power supply, neutral line: N (0VAC)  
P3、4、5、6—control external load, neutral line: N1、N2、N3、N4(0VAC)  
P7—control external load, electrical heat: HEAT (control output 220VAC)  
P8—control external load, health function: OXYGEN (control output 220VAC)  
P9—control external load, humidification: HUMI (control output 220VAC)  
P10—control external load, SWING(control output 220VAC)  
P11—control external load, WATER PUMP(control output 220VAC)  
P12—control external load, indoor fan motor low speed: L(control output 220VAC)  
P13—control external load, indoor fan motor mid speed: M(control output 220VAC)  
P14—control external load, indoor fan motor high speed: H(control output 220VAC)  
P15—communication with fixed frequency single outdoor unit: COMM(0~220VAC)  
P16—input control, signal live line: L'(220VAC)  
P17—input control, signal neutral line: N'(0VAC)  
CN1—input port of transformer (220VAC)  
CN2—input port 1 of transformer (no use)  
CN3—input port 2 of transformer (no use)  
CN4—input port 3 of transformer (1-2、14VAC, 3-4、12VAC)  
CN5—input control, connecting port to wired controller: CONTROLLER (three bits: 1. power supply: 12VAC, 2. power supply: 0VAC, 3. communication: COMM.) .  
CN6—input control, ambient temp.-coil temp. sensor connecting port: ROOM/PIPE (1-2、ROOM, 3-4、PIPE.)  
Indoor ambient temp. sensor:  $R_{25}=23\text{K}\Omega \pm 2.5\%$ ,  $B_{25/50}=4200\text{K} \pm 3\%$ , range: (-40, 80)  
Indoor coil temp. sensor:  $R_{25}=10\text{K}\Omega \pm 3\%$ ,  $B_{25/50}=3700\text{K} \pm 3\%$ , range: (-20, 90)  
CN7—control external load, fresh air control: FRESH (1. blank, 2. power supply 0VDC, 3. control output: 12VDC.)  
CN8—input signal: FREEZE (no use)  
CN9—input control (no use)  
CN10—communication with fixed frequency single outdoor unit: (0~12VDC)  
CN11—input signal, door switch: DOOR (1-2 short circuit is normal, cut off P8 output)  
CN12—input signal, external alarm input: ALARM (1-3 short circuit is normal, if cut off, air conditioner stops work.)  
**Note: For convertible type, cassette type, duct type units, CN11 and CN12 must be in short circuit, or PCB will display failure information.**  
CN13—input signal, wiring port of remote receiver board: RECEIVE BOARD (1. power supply 5VDC, 2. power supply 0VDC, 3. remote signal, 4. signal output of running lamp 0VDC, 5. signal output of timer lamp 0VDC, 6. signal output of power lamp 0VDC, 7. signal output of water pump running lamp 0VDC)  
CN14—control external load, auto elevating function (1. signal of door switch close, 2. output of elevating direction control 0VDC, 3. output of elevating power control 0VDC, 4. power supply 12VDC)

CN15—input signal, detecting water level of float switch (1-3 short circuit is normal, cut off shows that level exceeds the limitation) .If float switch cuts off or occurs other failure, LED1 will flash 10 times.

CN16—input control, wiring port of central controller: REMOTE (1、RS485-B, 2、RS485-A.)

CN17—output signal, output signal of failure alarm, control external load, 12V/ALM (1. control output 0VDC, 2. power supply 12VDC)

CN18—output signal (no use)

CN19—control external load, swing 1 (1、16VDC, 2、0VDC, 3、0VDC, 4、0VDC, 5、0VDC.) .

CN20—control external load, swing 2 (1、16VDC, 2、0VDC, 3、0VDC, 4、0VDC, 5、0VDC.) .

CN21—input signal, spring switch, CHECK (1、input signal of earthing, 2. power supply 0VDC)

CN22—short circuit means selecting single split communication type.( no use)

CN23—short circuit means selecting multi split communication type.( no use)

#### **0010451167E PCB information – function selection (ON is 1, OFF is 0)**

The standard condition for PCB in factory

SW1: 4 bits are OFF

SW2: 4 bits are OFF

SW3: 4 bits are ON

SW4: 2 bits are ON

SW5: 4 bits are ON

SW1-SW2: used for indoor unit to set unit address from 1 to 16'

SW3-SW5: used for indoor unit to select different functions.(every dip switches are corresponding to J1-J10.

SW2-4—logistic relationship of control function (door card control and remote/ wired control) 0 means logistic relationship is “and”, 1 means the later coming is preferential.

J1, SW3-1—function selection-control type: 1 means remote control, 0 means wired control.

J2, SW3-2—function selection-temperature compensation in heating mode: 1means “yes”, 0means “no”.

J3, SW3-3—function selection-outdoor communication: 1means “yes”, 0means “no”. This PCB must be 1.

J4, SW3-4—function selection-heat pump unit: 1means “heat pump”, 0means “cooling only”.

1/60—test in short circuit, but in operation short circuit mustn't be permitted.

CHECK—short spring switch control, it also can be used as switch of convertible type except for testing.

J5, SW4-1—function selection-outdoor pressure switch control function(if outdoor is without PCB):

1means the pressure switch is invalid, 0 means the pressure switch is valid.

J6, SW4-2—function selection –outdoor defrosting temp. sensor control function(when outdoor is without PCB): 1means outdoor defrost temp. sensor is invalid; 0 means outdoor defrost temp. sensor is valid.

J7, SW5-1—function selection –swing mode: 1 means common (simultaneous motor) , 0 means special (swing motor).

J8, SW5-2—function selection – system combination: 1means fixed frequency single unit, 0 means fixed frequency multi split.

J9, SW5-3—function selection –group control: 1 stands for the master unit (its address in wired controller is 0), 0 stands for the slave units (the address should be set by the dip switch, their addresses only can be in the range: 1~15)

J10, SW5-4—function selection –preset: 1 no meaning, 0 no meaning.

#### **0010451167E PCB information- control type**

Control type selection between remote and wired: select by dip switch J1, SW3-1 (1 means remote control; 0 means wired control.)

For remote control type, please use remote controller YR-H71, and a remote receiver is equipped with indoor unit. For wired control type, wired controller YR-E12 will be used, 3-core shielded wire is equipped with

indoor unit.

Door card control: controls ON/OFF, the start up setting will comply with last time request memorized according to condition memorize function. Its difference with emergency switch of convertible type unit lies: the emergency switch control will perform in the condition: 24degrees, auto fan speed in auto mode.

The function combination between door card and remote/wired control type: select by dip switch: SW2-4 (0 means "and", 1 means later coming is preferential.)

Dip switch position in wired control type: Only one indoor unit of all indoor units connected with wired controller is the master unit, whose address is 0, function selection switch (J9, SW5-3) is 1. The others are slave units, and the quantity can be 0~15, whose addresses are (SW1:1~4) from 1~15, and cannot repeat.

Wiring request in wired control type: the wired controller ports A-B-C are connected with indoor port CN5 (1-2-3) through 3-core shield wire. Requirements:

1. Port A only connects with either of indoor port CN5 (1)
2. Port B connects with port CN5 (2) of all indoor units.
3. Port C connects with port CN5 (3) of all indoor units.

Dip switch position in central control type: the addresses (SW1:1~4; SW2:1~4) of indoor units connected with central controller can not repeat. In principle, they should be in the order from small to big.

Wiring request in central control type: port A-B is connected with indoor port CN16 (A-B) through 2-core shield wire. Requirements:

1. Port A connects with port CN16 (A) of all indoor units.
2. Port B connects with port CN16 (B) of all indoor units.

When only use remote control type, please select remote control unit, and install according to installation manual, there is no other special request.

When only use wired control type, please select wired control unit, and install according to installation manual. When control multi indoor units, take care the requirements of dip switch and wiring, there is no other special request.

When only use central control type, please firstly install according to air conditioner requests and set the dipswitch, there is no other special request.

When central control type (128×) and remote control type are used simultaneously, set the dip switch according to central control type, there is no other special request.

When central control type (128×) and wired control type (16×) are used simultaneously, max. indoor units sets: 128×16 can be controller. Address setting of central controller can be met firstly, and then modulate the address setting of slave unit wired controlled.

#### **LED in indoor PCB:**

1. LED1: is the state lamp for remote receiver as well as failure lamp. If indoor unit is normal, LED1 is on, or if failure occurs, LED1 flashes regularly, and you can adjust failure type according to the flash times.
2. LED2: is used for multi split units as communication lamp. If communication between indoor and outdoor is normal, LED2 will be on.
3. LED3: is used for single split units as communication lamp. If communication between indoor and outdoor is normal, LED3 will be on.
4. LED4、LED5: is the lamp that shows the data receiving or sending between wired controller and PCB, If LED4、LED5 be on in turn, communication between wired controller and PCB is normal.



### 10.5 Sensor characteristic

Model	Name	Code	Sub-part code	characteristic
HCFU-42CH03 HCFU-42HK03	Indoor ambient temp. sensor	001A3900005	001A3900003	R25=23K $\Omega$ $\pm$ 2.5% B25/50=4200K $\pm$ 3%
	Indoor coil temp. sensor	001A3900006	001A3900004	R25=10K $\Omega$ $\pm$ 3% B25/50=3700K $\pm$ 3%
	Outdoor compressor vent sensor	0010450398	001A3800096	R80=50K $\Omega$ $\pm$ 3% B25/80=4450K $\pm$ 3%
	Outdoor defrost sensor	0010451314	001A3800091	R25=5K $\Omega$ $\pm$ 3% B25/50=3700K $\pm$ 3%
	Outdoor ambient temp. sensor	001A3900110	001A3800090	R25=5K $\Omega$ $\pm$ 3% B25/50=4200K $\pm$ 3%

### 11. Troubleshooting

#### 11.1 System failure

If the refrigerant in the system cannot flow fluently or the airflow circles more slowly, please check due to the following procedures.

Cooling:

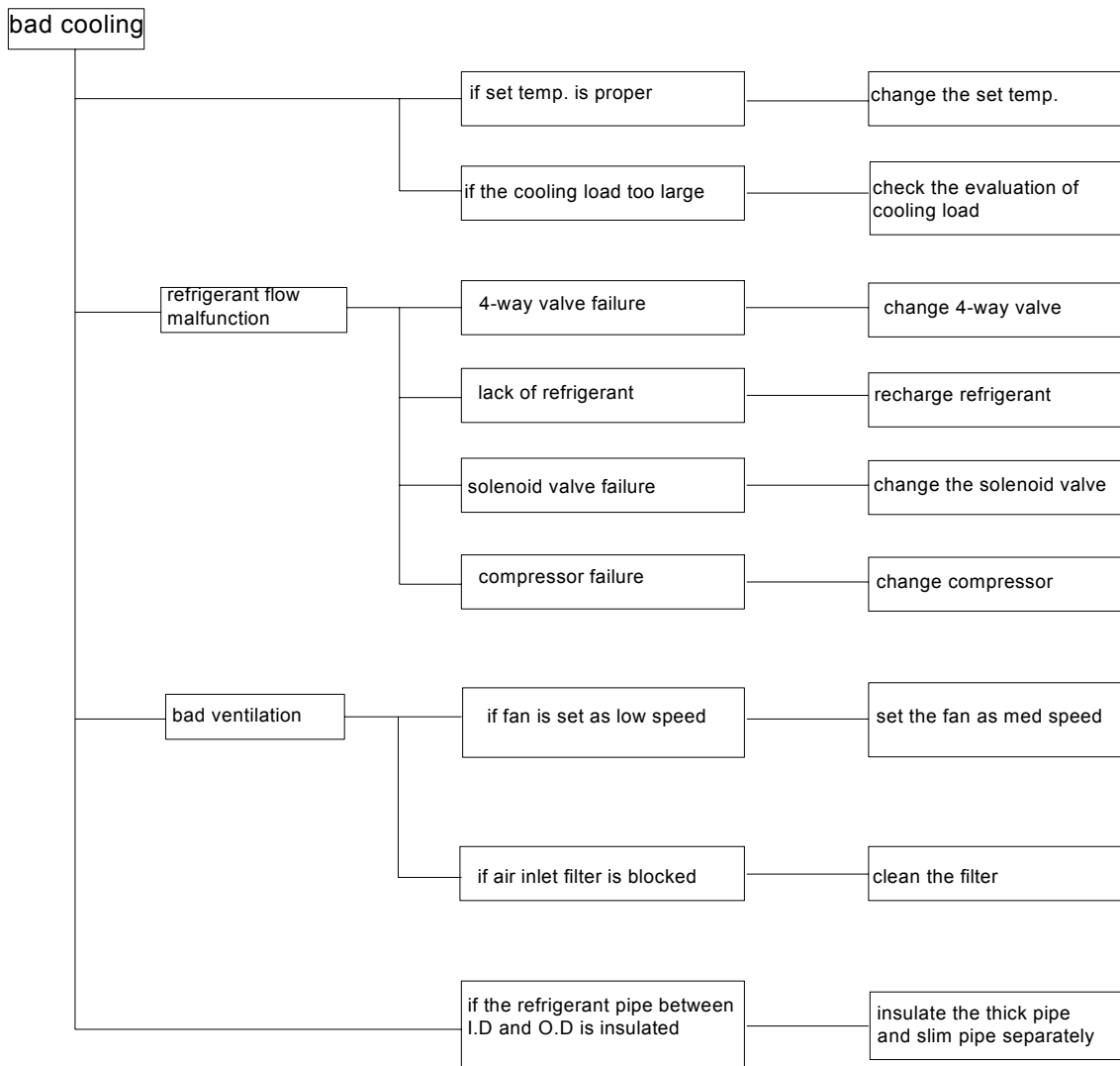

Figure 1

### 11.2 Failure code

Please refer to control function part, page 24 and 25.

### 11.3 Diagnose and troubleshooting:

#### 1) Sensor failure

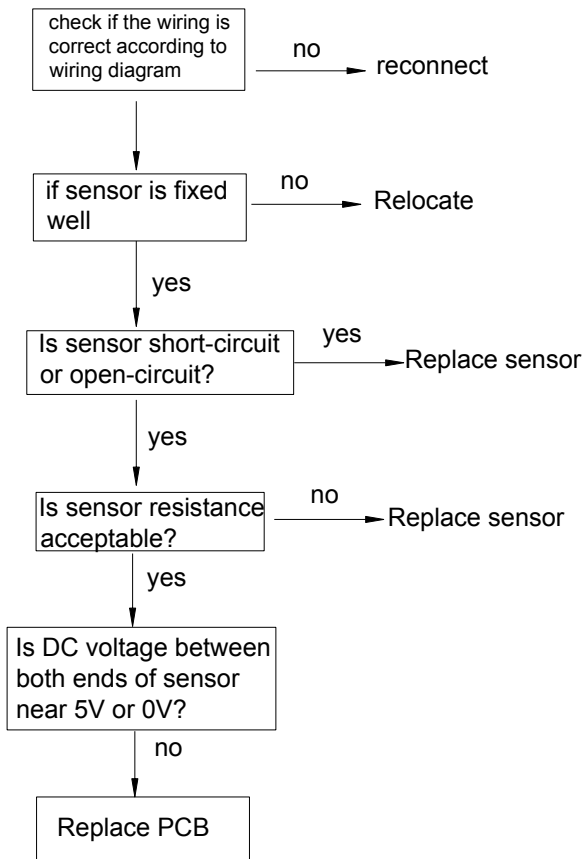

#### 2) Communication failure between operation panel and indoor unit

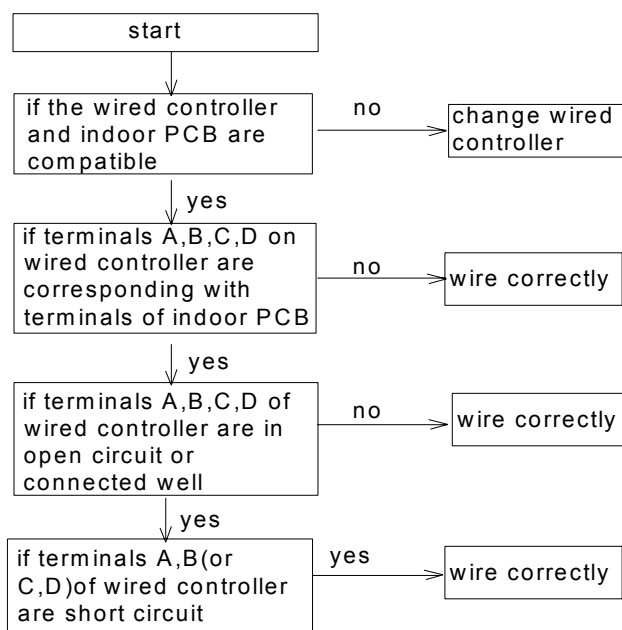

### 3) Low pressure abnormal

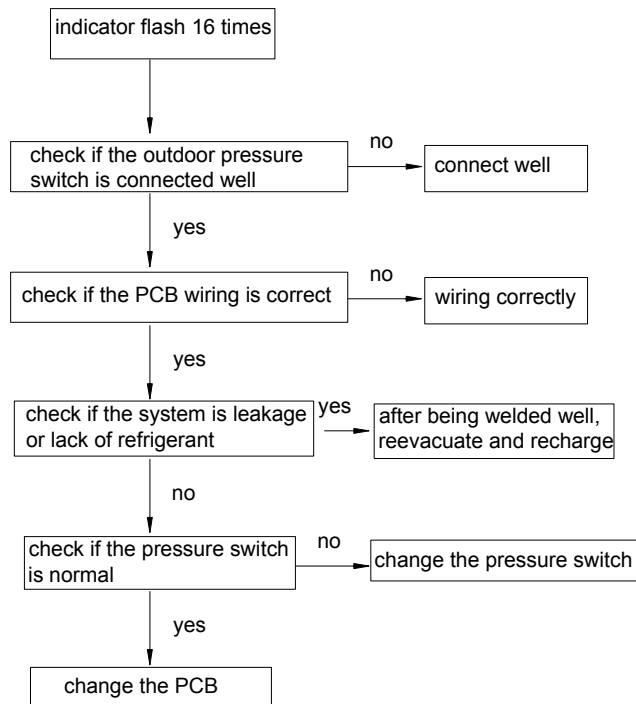

If there is other failure, please check if the dip switch is correct.

### 4) Communication failure between outdoor and indoor unit

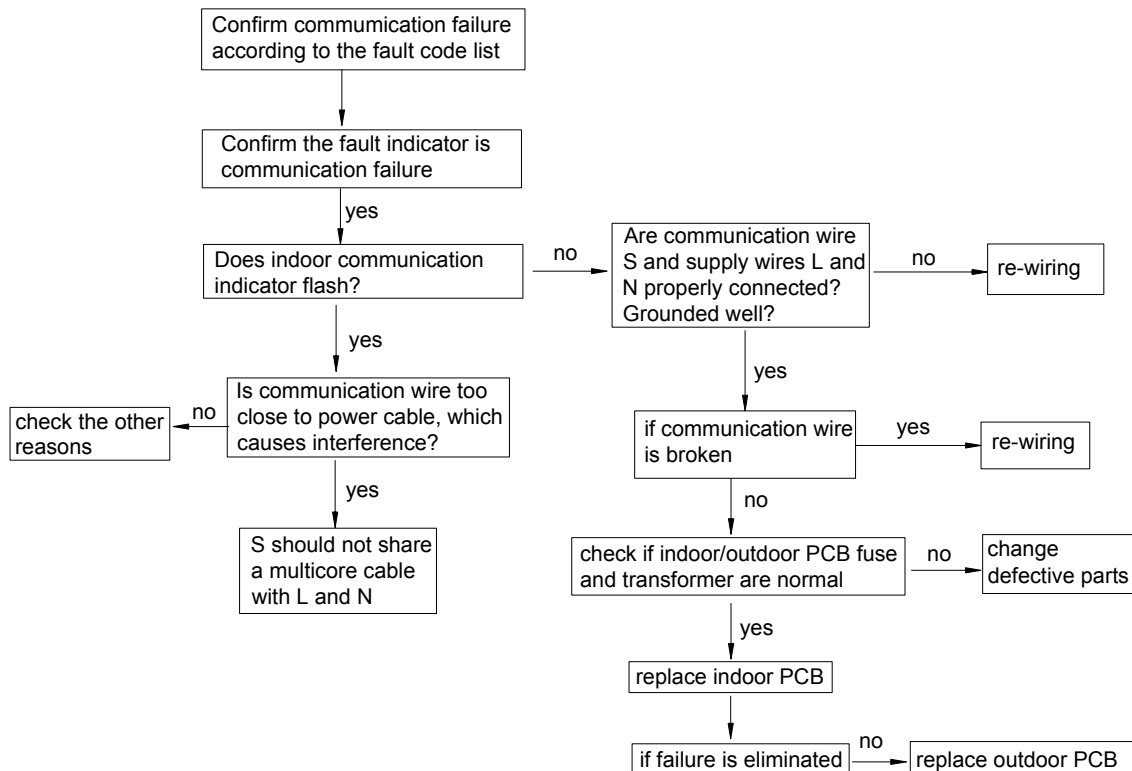

### 5) High pressure failure

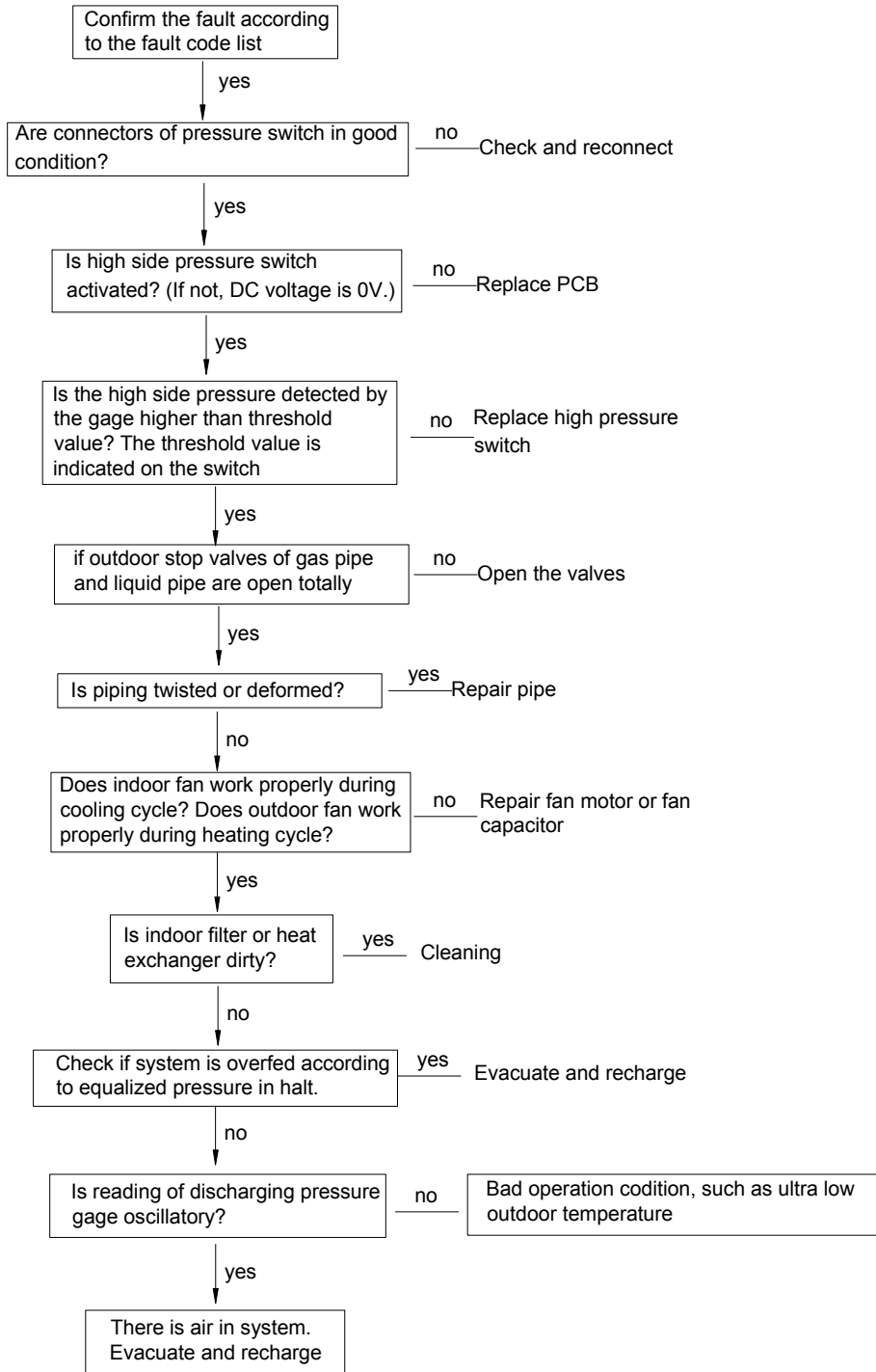

### 6) Overcurrent protection

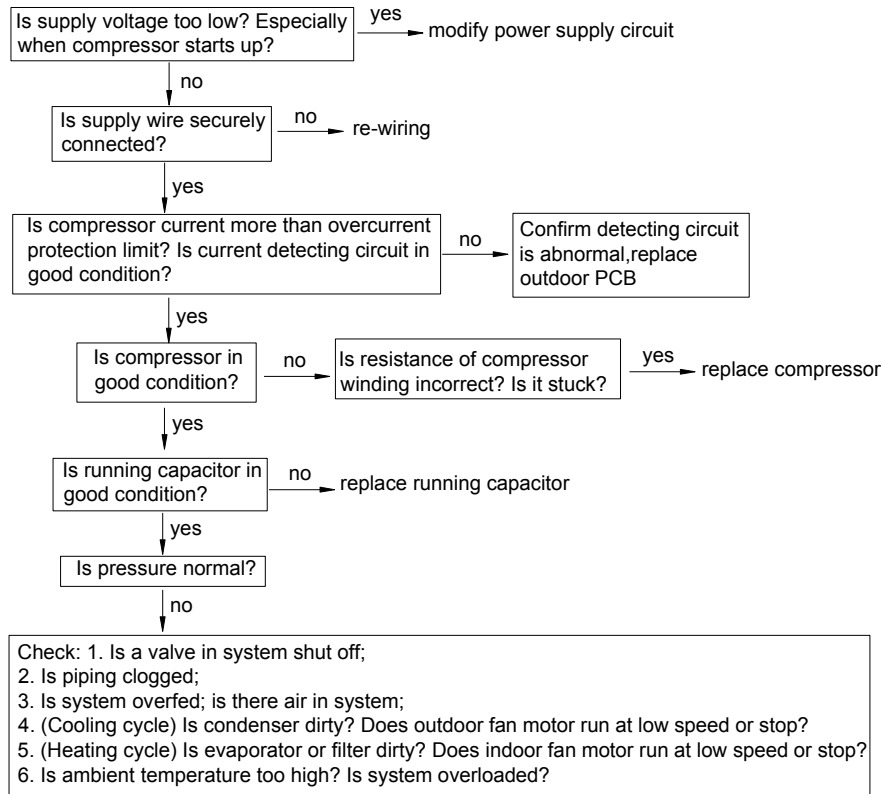

### 7) Drainage failure

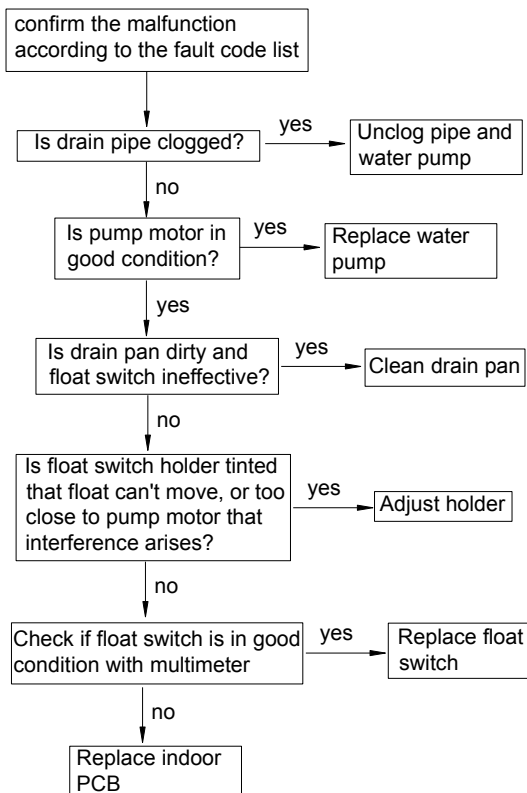

Note: Float switch is close in normal state, when being activated, it is open. Voltage between both ends is 0V when close, approximately 5V when open.

# Sincere Forever

**Haier Group**

---

---

**Haier Industrial Park, No.1, Haier Road**

**266101, Qingdao, China**

**<http://www.haier.com>**