

# Service Manual

## Commercial Air Conditioning

### Convertible Type R22 Cooling Only Series

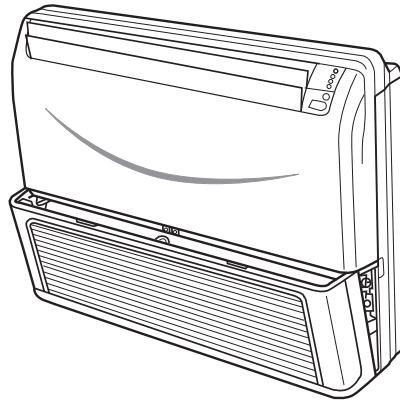

HCFU-14C03 ( AC142ACMAA+AU142AFMAA)  
HCFU-18CC03 ( AC182ACMBA+AU182AFMBA)  
HCFU-28CC03 ( AC282ACMBA+AU28AHMCA )  
HCFU-36C03 ( AC36NACMAA+AU36NAIMBA)  
HCFU-42CC03 ( AC42NACMCA+AU42NAIMBA)

#### ● Features

- Auto-restart function
- Group control(with a group controller)
- Auto-changeover
- Compact design of indoor unit
- Weekly timing(with a weekly timer)
- With new environment friendly refrigerant R407C

Haier Group

---

## CONTENTS

Contents.....	1
1. Description of Products & Features.....	1
2. Specifications.....	3
3. Safety precaution.....	9
4. Net dimensions of indoor and outdoor unit.....	11
5. Installation instructions .....	17
6. Parts and functions .....	28
7. Remote controller functions.....	31
8. Refrigerant diagram.....	43
9. Electrical control functions.....	44
10. Diagnostic information(trouble shooting).....	51
11. Electrical data.....	56
12. Exploded views and parts lists.....	67
13. Performance curves.....	87
14. Noise level charts.....	93
15. Air velocity distribution .....	94

# 1 DESCRIPTION OF PRODUCTS & FEATURES

## 1.1 Products coding direction

Old code

H CFU - 42 C C 03

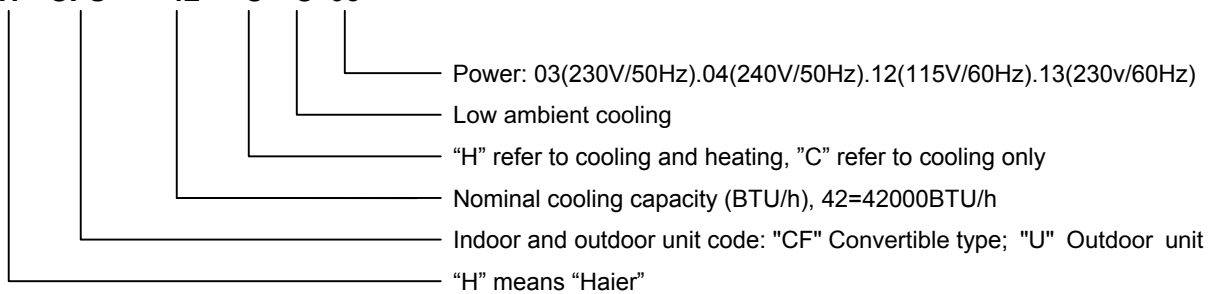

New code

A C 42 N A C M C A

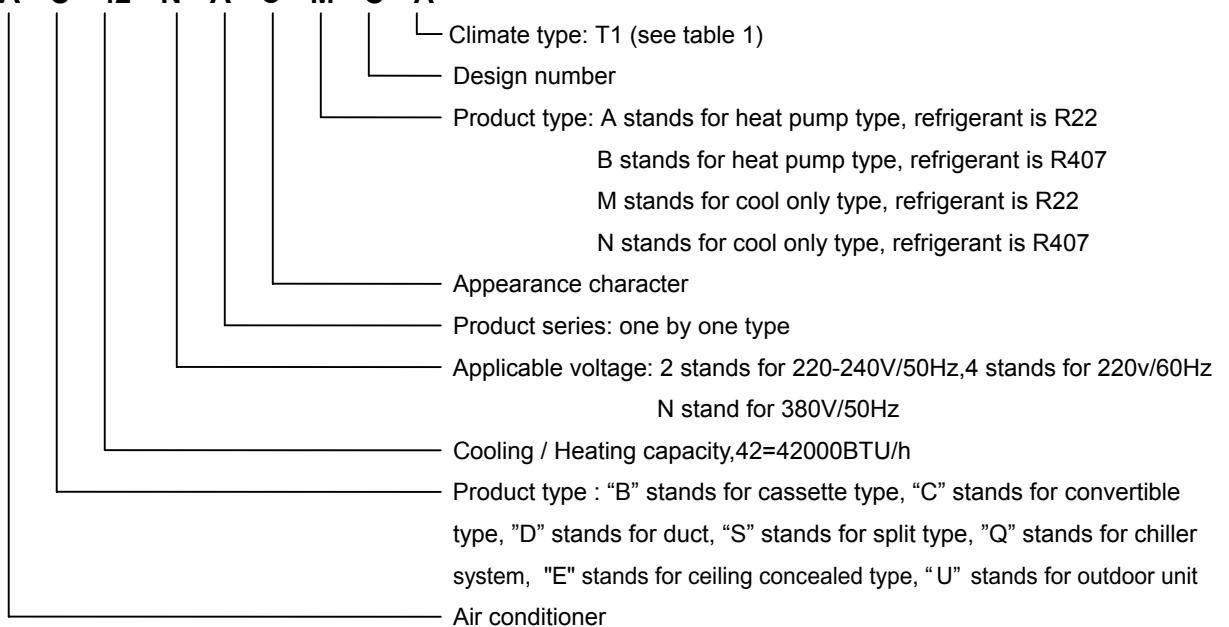

## 1.2 Brief Introduction to T1、T2、T3 working condition

Table 1

Type of Air Conditioner	Climate type		
	T1	T2	T3
Cool only	18°C~43°C	10°C~35°C	21°C~52°C
Heat pump	-7°C~43°C	-7°C~35°C	-7°C~52°C
Electricity heating	~43°C	~35°C	~52°C

## 1.3 Operating Range of air conditioners

Low ambient cooling

Operation	Operation Range Outside / Inside
Cooling	15 <sup>0</sup> C – 43 <sup>0</sup> C
Dehumidifying	15 <sup>0</sup> C – 43 <sup>0</sup> C

### 1.4 Products characteristic

- (1).Ceiling/console convertible,flexible installation,convenient maintenance,saving the users' expenditures
- (2).Adopting single-phase or three-phase power supply,applicable for household and commercial usage
- (3).Dual air outlet design,floor air blowing,accelerating the indoor air circulation, quick temperature adjustment
- (4).Long-distance air blowing,large power,large cooling/heating ratio
- (5).Intelligent remote control,convenient and flexible control
- (6).Super-slim indoor unit design,luxury and nice-looking,saving space,harmonious and unitive with the indoor environment
- (7).Adopting screw-fastening for the air inlet grill,firmly fixed;adopting slipway insert-lock fastening method for the filter screen,convenient cleaning or replacing the filter screen without opening the air inlet grill.
- (8).Group control,units up to 128 sets can be controlled

**2 SPECIFICATIONS**

Item		Model	HCFU-14C03		
Function			Cooling	Heating	
Capacity		BTU/h	14000	/	
Total power input		W	2000	/	
EER or COP		BTU/W	7.00	/	
Dehumidifying capacity		10 <sup>-3</sup> ×m <sup>3</sup> /h	1		
Power source		PH-V-Hz	1PH, 220V-230V, 50HZ		
Running current/Starting current		A	9.4/40.7	/	
Power cable			/		
Indoor unit	Unit model		AC142ACMAA		
	Fan	Type × Number		CENTRIFUGAL×2	
		Speed	r/min	1070/1000/940	
		Air-flow(H-M-L)	m <sup>3</sup> /h	900	
	Heat exchanger	Type / Diameter		TP2M/9.52	
		Flow		2/2	
		Total area	m <sup>2</sup>	0.199	
		Temp. scope	°C	2-7	
	Dimension (L×W×H)	External	mm×mm×mm	900×655×199	
		Package	mm×mm×mm	1150×750×300	
	Drainage pipe (material , I.D./O.D.)			PVC 18/20	
	Control type (wireless/wired)			wired	
	Fresh air hole dimension		mm	/	
	Noise level (H-M-L)		dB(A)	48/44/38	
Weight (net / gross)		kg	30/39		
Panel	Dimension (L×W×H)	External	mm×mm×mm	/	
		Package	mm×mm×mm	/	
	Weight (net / gross)		kg	/	
Outdoor unit	Unit model		AU142AFMAA		
	Compressor	Model / Manufacture		ZR34K3E-TFJ-522 / COPELAND	
		Type		scroll	
	Fan	Type × Number		Axial-flow×1	
		Speed	r/min	820	
		Air-flow(H-M-L)	m <sup>3</sup> /h	700/-/-	
	Heat exchanger	Type / Diameter		Tupu/9.52	
		Flow		2/2	
		Total area	m <sup>2</sup>	0.225	
		Temp. scope	°C	43-60	
	Dimension (L×W×H)	External	mm×mm×mm	810×288×680	
		Package	mm×mm×mm	960×406×760	
	Drainage pipe (material , I.D./O.D.)			PVC,18/20	
	Refrigerant control method			Capillary	
Defrosting			Auto		
Noise level (H-M-L)		dB(A)	52/-/-		
Four way valve			/		
Weight (net / gross)		kg	59/66		
Piping	Refrigerant	Type		R22	
		Charge	kg	1.8	
	Pipe	Liquid	mm	6.35	
		Gas	mm	15.88	
		Connect method		FLARED	
	Between I.U. & O.U.	Drop	m	MAX :5	
Piping length		m	MAX :15		

## SPECIFICATIONS

Item		Model	HCFU-18CC03		
Function			Cooling	Heating	
Capacity		BTU/h	18000	/	
Total power input		W	2000	/	
EER or COP		BTU/W	9.00	/	
Dehumidifying capacity		10 <sup>-3</sup> ×m <sup>3</sup> /h	2.1		
Power source		PH-V-Hz	1PH, 220V-230V, 50HZ		
Running current/Starting current		A	8/12.6	/	
Power cable			/		
Indoor unit	Unit model (color)		AC182ACMBA		
	Fan	Type × Number		CENTRIFUGAL×2	
		Speed	r/min	1070	
		Air-flow(H-M-L)	m <sup>3</sup> /h	1050	
	Heat exchanger	Type / Diameter		TuPu/9.52	
		Flow		2/2	
		Total area	m <sup>2</sup>	0.199	
		Temp. scope	°C	2-7	
	Dimension (L×W×H)	External	mm×mm×mm	990×655×199	
		Package	mm×mm×mm	1150×750×300	
	Drainage pipe (material , I.D./O.D.)			PVC -/18	
	Control type (wireless/wired)			wired	
	Fresh air hole dimension		mm	/	
	Noise level (H-M-L)		dB(A)	48/-/-	
Weight (net / gross)		kg	30/39		
Panel	Dimension (L×W×H)	External	mm×mm×mm	/	
		Package	mm×mm×mm	/	
	Weight (net / gross)		kg	/	
Outdoor unit	Unit model (color)		AU182AFMBA		
	Compressor	Model / Manufacture		SHW33TC-U / HITACHI	
		Type		scroll	
	Fan	Type × Number		Axial-flow×1	
		Speed	r/min	820	
		Air-flow(H-M-L)	m <sup>3</sup> /h	700/-/-	
	Heat exchanger	Type / Diameter		TUPU/9.52	
		Flow		2/2	
		Total area	m <sup>2</sup>	0.534	
		Temp. scope	°C	43-60	
	Dimension (L×W×H)	External	mm×mm×mm	870×300×700	
		Package	mm×mm×mm	960×406×760	
	Drainage pipe (material , I.D./O.D.)			PVC, 18/26	
	Refrigerant control method			Capillary	
Defrosting			Auto		
Noise level (H-M-L)		dB(A)	52/-/-		
Four way valve			/		
Weight (net / gross)		kg	59/66		
Piping	Refrigerant	Type	R22		
		Charge	kg	1.85	
	Pipe	Liquid	mm	6.35	
		Gas	mm	15.88	
		Connect method		FLARED	
	Between I.U. & O.U.	Drop	m	MAX :5	
Piping length		m	MAX :15		

## SPECIFICATIONS

Item		Model		HCFU-28CC03		
Function				Cooling	Heating	
Capacity		BTU/h		28000	/	
Total power input		W		2800	/	
EER or COP		BTU/W		10	/	
Dehumidifying capacity		10 - <sup>3</sup> ×m <sup>3</sup> /h		3		
Power source		PH-V-Hz		1PH,220V~230V,50Hz		
Running current/Starting current		A		11.8/14.5	/	
Power cable				/		
Indoor unit	Unit model (color)				AC282ACMBA	
	Fan	Type × Number		CENTRIFUGAL×2		
		Speed	r/min	1350/-/-		
		Air-flow(H-M-L)	m <sup>3</sup> /h	1300		
	Heat exchanger	Type / Diameter		TUPU/9.52		
		Flow		2/2		
		Total area	m <sup>2</sup>	0.24		
		Temp. scope	°C	2-7		
	Dimension (L×W×H)	External	mm×mm×mm	1320×715×235		
		Package	mm×mm×mm	1380×770×300		
	Drainage pipe (material , I.D./O.D.)				PVC 18/26	
	Control type (wireless/wired)				wired	
	Fresh air hole dimension		mm	/		
	Noise level (H-M-L)		dB(A)	42/-/-		
Weight (net / gross)		kg	46/52			
Panel	Dimension (L×W×H)	External	mm×mm×mm	/		
		Package	mm×mm×mm	/		
	Weight (net / gross)		kg	/		
Outdoor unit	Unit model (color)				AU28AHMCA	
	Compressor	Model / Manufacture		ZR34K3E-TFJ-522 / Copeland		
		Type		scroll		
	Fan	Type × Number		Axial-flow×1		
		Speed	r/min	840/-/-		
		Air-flow(H-M-L)	m <sup>3</sup> /h	3240		
	Heat exchanger	Type / Diameter		TUPU/9.52		
		Flow		3/3		
		Total area	m <sup>2</sup>	0.62		
		Temp. scope	°C	43-60		
	Dimension (L×W×H)	External	mm×mm×mm	948×830×340		
		Package	mm×mm×mm	1050×979×440		
	Drainage pipe (material , I.D./O.D.)				PVC,18/26	
	Refrigerant control method				Capillary	
Defrosting				Auto		
Noise level (H-M-L)		dB(A)	58/-/-			
Four way valve				/		
Weight (net / gross)		kg	70/85			
Piping	Refrigerant	Type	R22			
		Charge	kg	2.28		
	Pipe	Liquid	mm	9.52		
		Gas	mm	15.88		
		Connect method		FLARED		
	Between I.U. & O.U.	Drop	m	MAX :15		
Piping length		m	MAX : 30			

## SPECIFICATIONS

Item		Model	HCFU-36C03		
Function			Cooling	Heating	
Capacity		BTU/h	28000	/	
Total power input		W	2800	/	
EER or COP		BTU/W	10.0	/	
Dehumidifying capacity		10 - <sup>3</sup> ×m <sup>3</sup> /h	3		
Power source		PH-V-Hz	3N,380V~400V,50Hz		
Running current/Starting current		A	12.5/60.1	/	
Power cable			/		
Indoor unit	Unit model (color)		AC36NACMAA		
	Fan	Type × Number		CENTRIFUGAL×2	
		Speed	r/min	1300/1200/1000	
		Air-flow(H-M-L)	m <sup>3</sup> /h	1300	
	Heat exchanger	Type / Diameter		TP2M/9.52	
		Flow		2/2	
		Total area	m <sup>2</sup>	0.221	
		Temp. scope	°C	2-7	
	Dimension (L×W×H)	External	mm×mm×mm	1320×715×235	
		Package	mm×mm×mm	1380×770×300	
	Drainage pipe (material , I.D./O.D.)			PVC 18/20	
	Control type (wireless/wired)			wired	
	Fresh air hole dimension		mm	/	
	Noise level (H-M-L)	dB(A)	35/32/29		
Weight (net / gross)	kg	40/57			
Panel	Dimension (L×W×H)	External	mm×mm×mm	/	
		Package	mm×mm×mm	/	
	Weight (net / gross)	kg	/		
Outdoor unit	Unit model (color)		AU36NAIMBA		
	Compressor	Model / Manufacture		ZR34K3E-TFJ-522 / Copeland	
		Type		scroll	
	Fan	Type × Number		Axial-flow×1	
		Speed	r/min	840/-/-	
		Air-flow(H-M-L)	m <sup>3</sup> /h	3240	
	Heat exchanger	Type / Diameter		TP2M/9.52	
		Flow		3/3	
		Total area	m <sup>2</sup>	0.62	
		Temp. scope	°C	43-60	
	Dimension (L×W×H)	External	mm×mm×mm	948×830×340	
		Package	mm×mm×mm	1050×979×440	
	Drainage pipe (material , I.D./O.D.)			PVC,18/20	
	Refrigerant control method			Capillary	
Defrosting			Auto		
Noise level (H-M-L)	dB(A)	58/-/50			
Four way valve			/		
Weight (net / gross)	kg	74/89			
Piping	Refrigerant	Type	R22		
		Charge	kg	1.85	
	Pipe	Liquid	mm	9.52	
		Gas	mm	15.88	
		Connect method		FLARED	
	Between I.U. & O.U.	Drop	m	MAX :15	
Piping length		m	MAX : 30		



# SPECIFICATIONS

Item		Model	HCFU-42CC03		
Function			Cooling	Heating	
Capacity		BTU/h	42000	/	
Total power input		W	4800	/	
EER or COP		BTU/W	8.75	/	
Dehumidifying capacity		10 - <sup>3</sup> m <sup>3</sup> /h	5		
Power source		PH-V-Hz	3N, 380V-400V, 50HZ		
Running current/Starting current		A	7.8/11	/	
Power cable			/		
Indoor unit	Unit model (color)		AC42NACMCA		
	Fan	Type × Number		CENTRIFUGAL×3	
		Speed	r/min	1300/1200/1000	
		Air-flow(H-M-L)	m <sup>3</sup> /h	1600	
	Heat exchanger	Type / Diameter		TUPU/9.52	
		Flow		3/3	
		Total area	m <sup>2</sup>	0.4	
		Temp. scope	°C	2-7	
	Dimension (L×W×H)	External	mm×mm×mm	1920×715×235	
		Package	mm×mm×mm	1980×761×295	
	Drainage pipe (material , I.D./O.D.)			PVC 18/20	
	Control type (wireless/wired)			wired	
	Fresh air hole dimension		mm	/	
	Noise level (H-M-L)		dB(A)	56/-/-	
Weight (net / gross)		kg	73/81		
Panel	Dimension (L×W×H)	External	mm×mm×mm	/	
		Package	mm×mm×mm	/	
	Weight (net / gross)		kg	/	
Outdoor unit	Unit model (color)		AU42NAIMBA		
	Compressor	Model / Manufacture		H23A62QDBEA / BRISTOL	
		Type		scroll	
	Fan	Type × Number		Axial-flow×2	
		Speed	r/min	840/-/-	
		Air-flow(H-M-L)	m <sup>3</sup> /h	6000	
	Heat exchanger	Type / Diameter		TP2M/9.52	
		Flow		5/5	
		Total area	m <sup>2</sup>	0.92	
		Temp. scope	°C	43-60	
	Dimension (L×W×H)	External	mm×mm×mm	948×1225×340	
		Package	mm×mm×mm	1050×1375×440	
	Drainage pipe (material , I.D./O.D.)			PVC,18/20	
	Refrigerant control method			Capillary	
Defrosting			Auto		
Noise level (H-M-L)		dB(A)	64/-/-		
Four way valve			/		
Weight (net / gross)		kg	85/105		
Piping	Refrigerant	Type		R22	
		Charge	kg	3.07	
	Pipe	Liquid	mm	9.52	
		Gas	mm	19.05	
		Connect method		FLARED	
	Between I.U. & O.U.	Drop	m	MAX :30	
Piping length		m	MAX : 50		

### 3 SAFETY PRECAUTIONS

- Please read these "Safety Precautions" first then accurately execute the installation work.
- Though the precautionary points indicated herein are divided under two headings, **△WARNING** and **△CAUTION** those points which are related to the strong possibility of an installation done in error resulting in death or serious injury are listed in the **△WARNING** section. However, there is also a possibility of serious consequences in relationship to the points listed in the **△CAUTION** section as well. In either case, important safety related information is indicated, so by all means, properly observe all that is mentioned.
- After completing the installation, along with confirming that no abnormalities were seen from the operation tests, please explain operating methods as well as maintenance methods to the user (customer) of this equipment, based on the owner's manual.

Moreover, ask the customer to keep this sheet together with the owner's manual.

#### **△ WARNING**

- This system should be applied to places of office, restaurant, residence and the like. Application to inferior environment such as engineering shop could cause equipment malfunction.
- Please entrust installation to either the company which sold you the equipment or to a professional contractor. Defects from improper installations can be the cause of water leakage, electric shocks and fires.
- Execute the installation accurately, based on following the installation manual. Again, improper installations can result in water leakage, electric shocks and fires.
- When a large air-conditioning system is installed to a small room, it is necessary to have a prior planned countermeasure for the rare case of a refrigerant leakage, to prevent the exceeding of threshold concentration. In regards to preparing this countermeasure, consult with the company from which you purchased the equipment, and make the installation accordingly. In the rare event that a refrigerant leakage and exceeding of threshold concentration does occur, there is the danger of a resultant oxygen deficiency accident.
- For installation, confirm that the installation site can sufficiently support heavy weight. When strength is insufficient, injury can result from a falling of the unit.
- Execute the prescribed installation construction to prepare for earthquakes and the strong winds of typhoons and hurricanes, etc. Improper installations can result in accidents due to a violent falling over of the unit.
- For electrical work, please see that a licensed electrician executes the work while following the safety standards related to electrical equipment, and local regulations as well as the installation instructions, and that only exclusive use circuits are used.  
Insufficient power source circuit capacity and defective installment execution can be the cause of electric shocks and fires.
- Accurately connect wiring using the proper cable, and insure that the external force of the cable is not conducted to the terminal connection part, through properly securing it. Improper connection or securing can result in heat generation or fire.
- Take care that wiring does not rise upward, and accurately install the lid/service panel. Its improper installation can also result in heat generation or fire.

### **△ WARNING**

- When setting up or moving the location of the air conditioner, do not mix air etc. or anything other than the designated refrigerant (please see nameplate) within the refrigeration cycle.
- Rupture and injury caused by abnormal high pressure can result from such mixing.  
Always use accessory parts and authorized parts for installation construction. Using parts not authorized by this company can result in water leakage, electric shock, fire and refrigerant leakage.
- The position of indoor unit must be above the floor 2.5m.

### **△ CAUTION**

- Execute proper grounding. Do not connect the ground wire to a gas pipe, water pipe, lightning rod or a telephone ground wire.  
Improper placement of ground wires can result in electric shock.
- The installation of an earth leakage breaker is necessary depending on the established location of the unit. Not installing an earth leakage breaker may result in electric shock.
- Do not install the unit where there is a concern about leakage of combustible gas.  
The rare event of leaked gas collecting around the unit could result in an outbreak of fire.
- For the drain pipe, follow the installation manual to insure that it allows proper drainage and thermally insulate it to prevent condensation. Inadequate plumbing can result in water leakage and water damage to interior items.

# NET DIMENSIONS OF INDOOR AND OUTDOOR UNIT

## 4 NET DIMENSIONS OF INDOOR AND OUTDOOR UNIT

Model: HCFU-14C03 HCFU-18CC03 Indoor unit

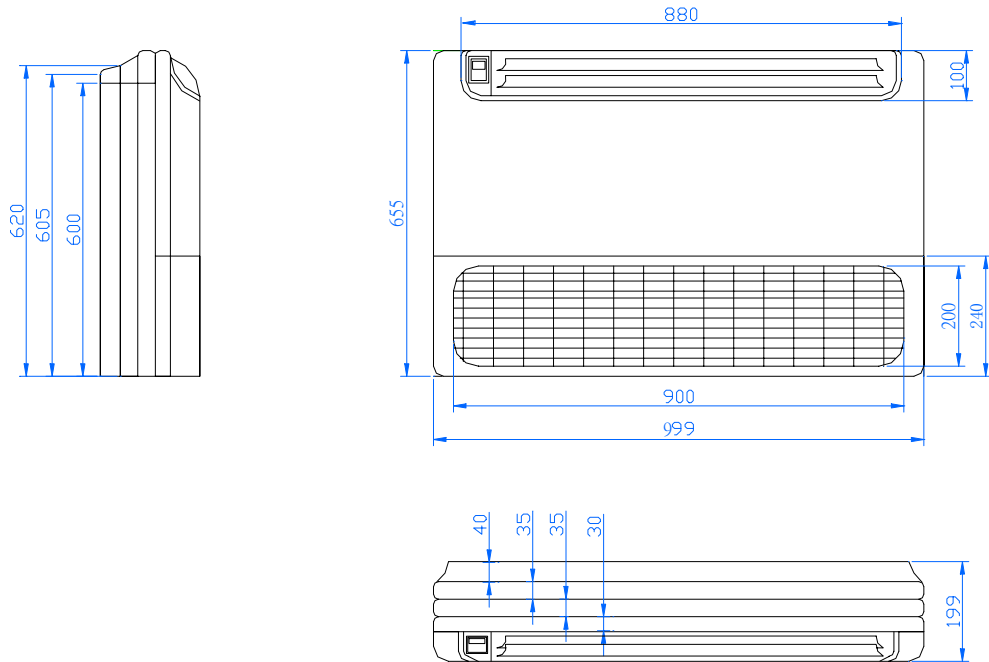

Model: HCFU-14C03 HCFU-18CC03 Outdoor unit

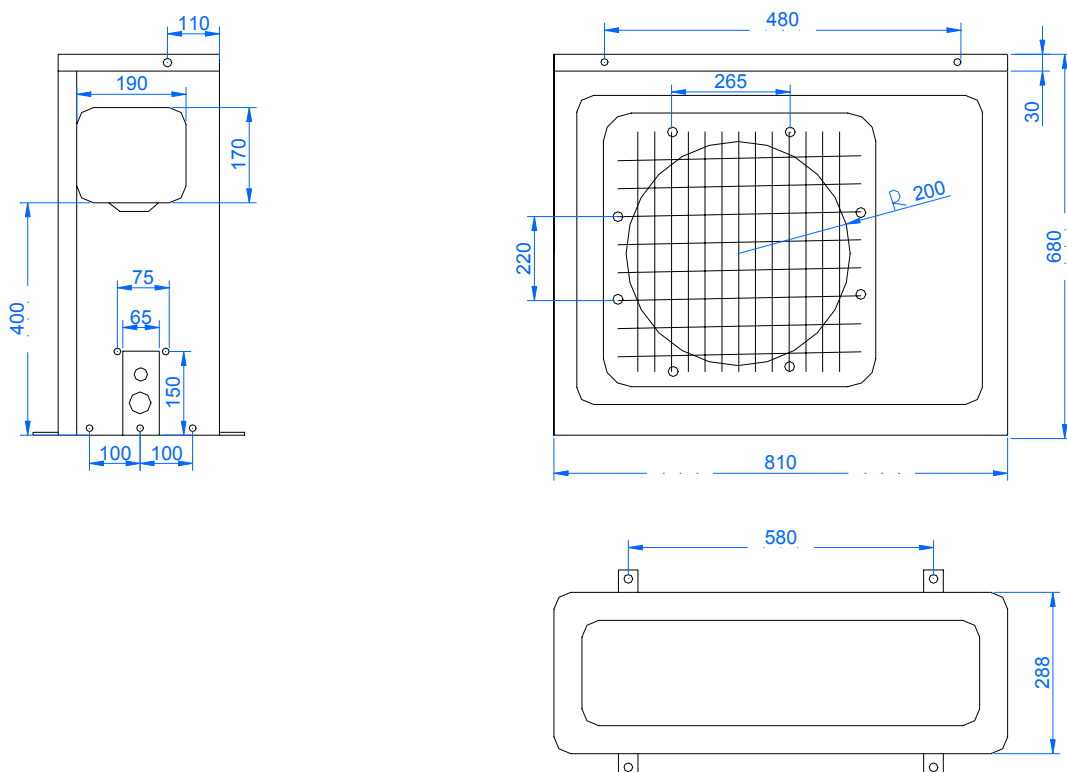

# NET DIMENSIONS OF INDOOR AND OUTDOOR UNIT

Model: HCFU-28CC03 Indoor unit

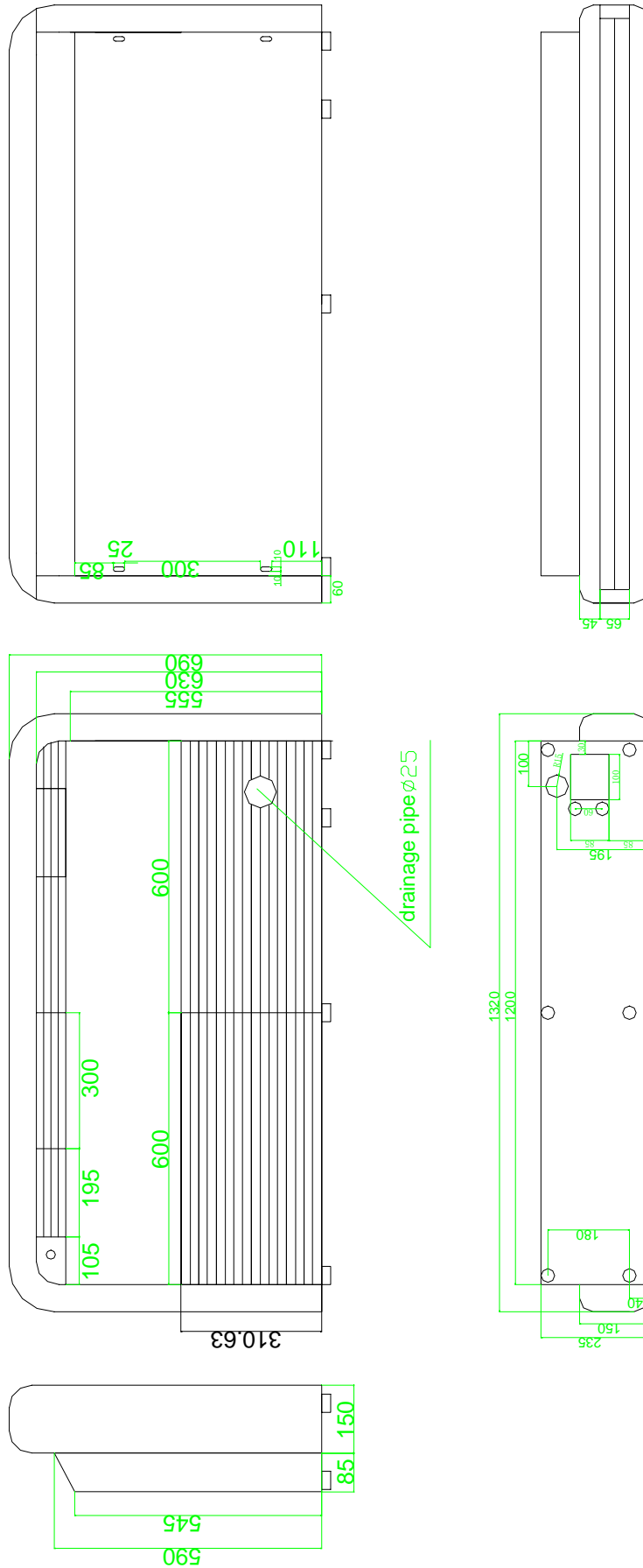

# NET DIMENSIONS OF INDOOR AND OUTDOOR UNIT

## Model: HCFU-28CC03 Outdoor unit

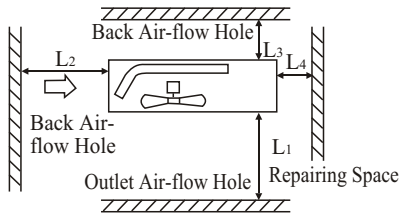
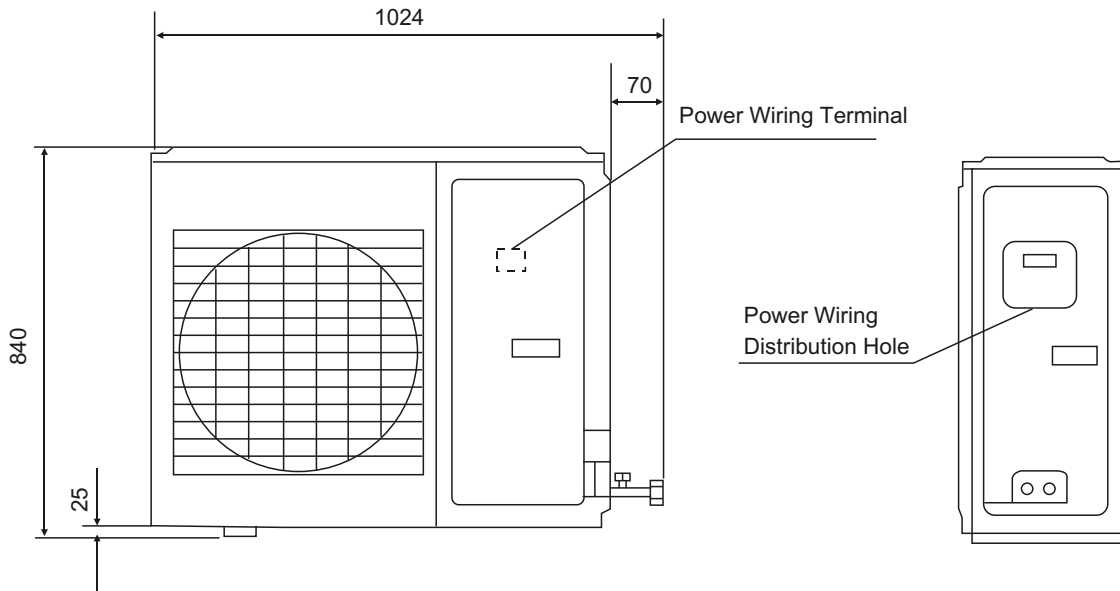
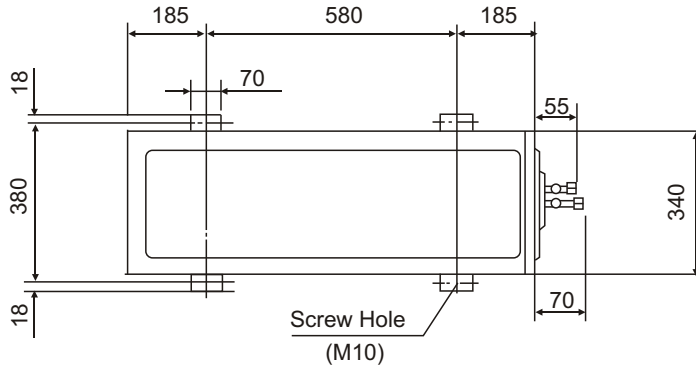

- Note (1) Fix the parts with screws  
 (2) Don't intake the strong wind directly to the outlet air-flow hole.  
 (3) A one meter distance should be kept from the unit top  
 (4) Don't block the surroundings of the unit with sundries.

### Installation Servicing Space(at Least)

Unit:mm

Installation Dimension	I	II	III
L <sub>1</sub>	Leave space	Leave space	500
L <sub>2</sub>	300	0	Leave space
L <sub>3</sub>	100	150	100
L <sub>4</sub>	0	0	0

# NET DIMENSIONS OF INDOOR AND OUTDOOR UNIT

Model: HCFU-36C03 HCFU-42CC03 Indoor unit

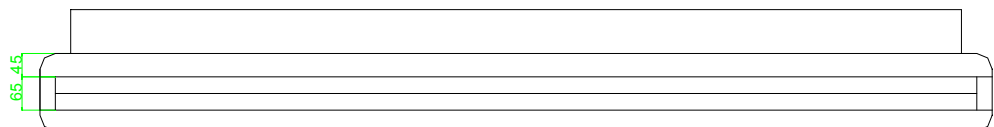
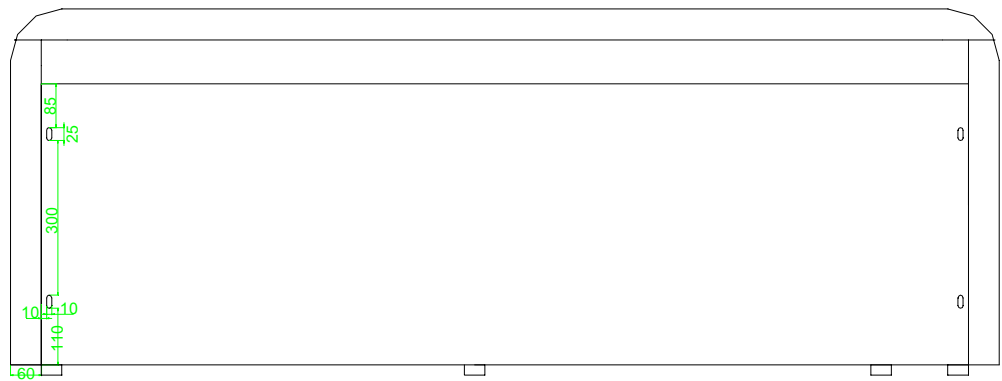
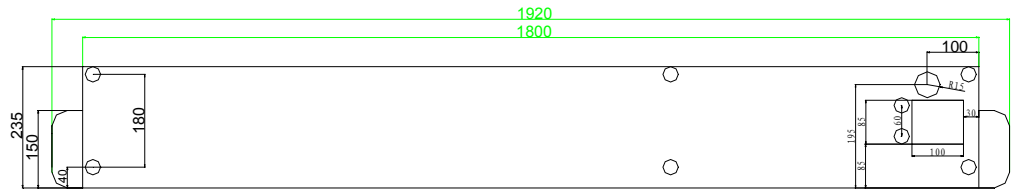
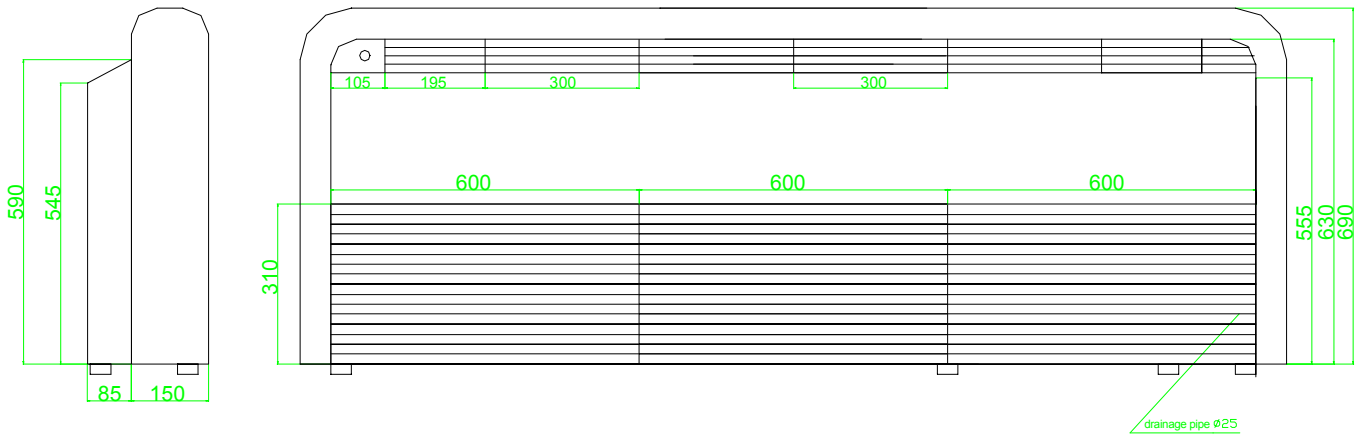

# NET DIMENSIONS OF INDOOR AND OUTDOOR UNIT

Model: HCFU-36C03 HCFU-42C03 Outdoor unit

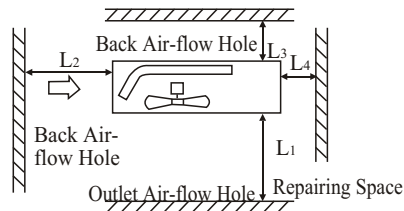
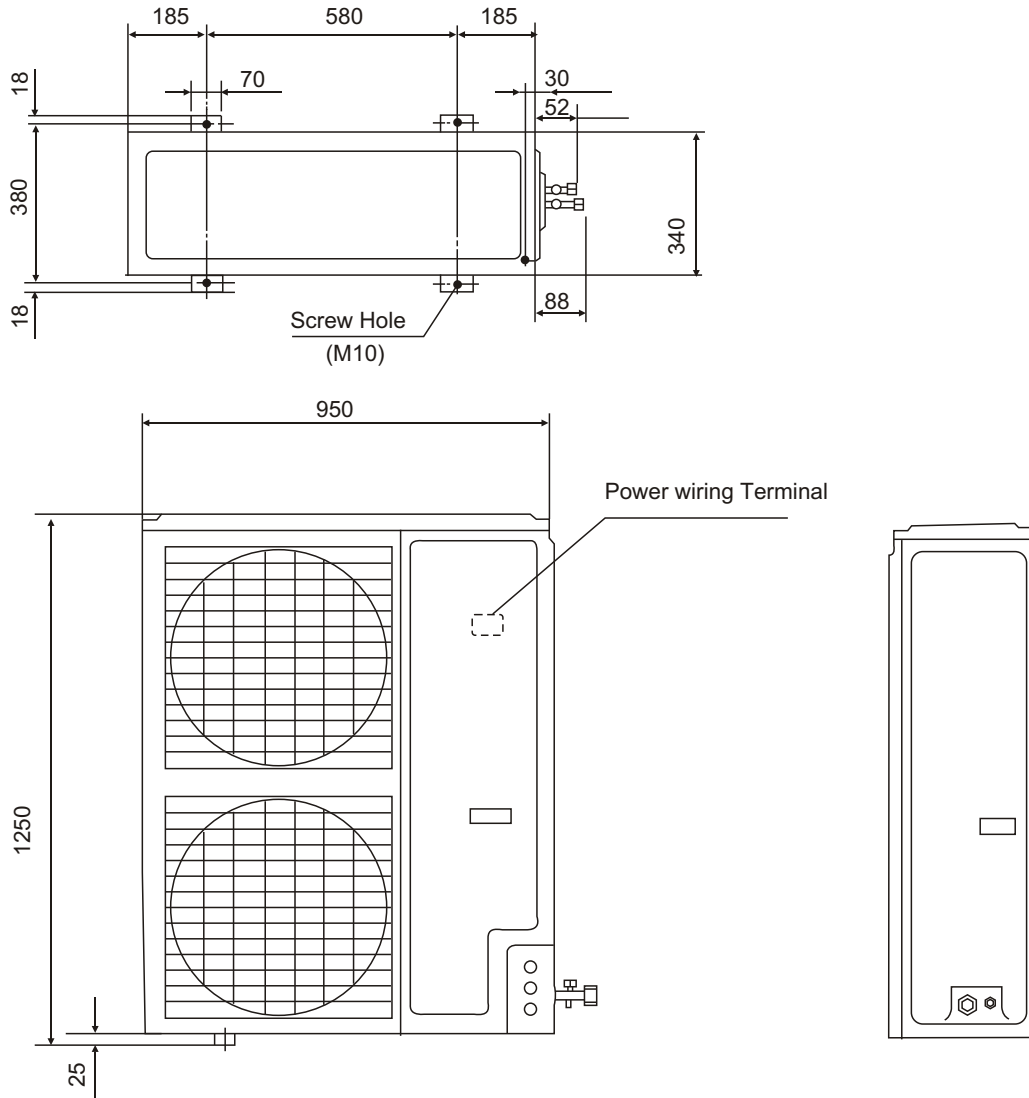

- Note :
- (1). Fix the parts with screws
  - (2). Don't intake the strong wind directly to the outlet air-flow hole.
  - (3). A one meter distance should be kept from the unit top
  - (4). Don't block the surroundings of the unit with sundries

Installation Servicing Space(at Least)

Unit:mm			
Installation Dimension	I	II	III
L <sub>1</sub>	Leave space	Leave space	500
L <sub>2</sub>	300	0	Leave space
L <sub>3</sub>	100	150	100
L <sub>4</sub>	0	0	0



## 5 INSTALLATION INSTRUCTIONS

For authorized service personnel only

⚠ WARNING
(1) For the room air conditioner to operate satisfactorily, install it as outlined in this installation manual.
(2) Connect the indoor unit and outdoor unit with the room air conditioner piping and cords available from our standard parts. This installation manual describes for the correct connections so that the installation set available from our standard parts should be used.
(3) Installation work must be performed in accordance with national wiring standards by authorized personnel only.
(4) Never cut the power cord, lengthen or shorten the cord, or change the plug.
(5) Also, do not use an extension cord.
(6) Plug in the power cord plug firmly. If the receptacle is loose, repair it before using the room air conditioner.
(7) Do not turn on the power until all installation work is done.

- Be careful not to scratch the room air conditioner when handling it.
- After installation, explain correct operation to the customer, according to the operating manual.
- Let the customer keep this installation manual because it will be used when the room air conditioner is serviced or moved.

### SELECTING THE MOUNTING POSITION

⚠ WARNING
Install at a place that can withstand the weight of the indoor and outdoor units and install positively so that the units will not topple or fall.

⚠ CAUTION
(1) Do not install where there is the danger of combustible gas leakage.
(2) Do not install near heat sources.
(3) If children under 10 years old may approach the unit, take preventive measures so that they cannot reach the unit.

Decide the mounting position with the customer as follows:

#### 1. INDOOR UNIT

- (1) Install the indoor unit level on a strong wall, floor, ceiling which is not subject to vibration.
- (2) The inlet and outlet ports should not be obstructed: the air should be able to blow all over the room.
- (3) Install the unit near an electric outlet or special branch circuit.
- (4) Do not install the unit where it will be exposed to direct sunlight.
- (5) Install the unit where connection to the outdoor unit is easy.
- (6) Install the unit where the drain pipe can be easily installed.
- (7) Take servicing, etc. into consideration and leave the spaces shown in Fig.1. Also install the unit where the filter can be removed.

NOTE: The appearance may be different from models.

#### 2. OUTDOOR UNIT

⚠ WARNING
(1) Install the unit where it will not be tilted by more than 5°
(2) When installing the outdoor unit where it may be exposed to the strong wind, fasten it securely.

- (1) If possible, do not install the unit where it will be exposed to direct sunlight. (If necessary, install a blind that does not interfere with the air flow.)
- (2) Install the outdoor unit in a place where it will be free from being dirty or getting wet by rain as much as possible.
- (3) Install the unit where connection to the indoor unit is easy.
- (4) During heating operation, drain water flows from the outdoor unit. Therefore, install the outdoor unit in a place where the drain water flow will not be obstructed. (Reverse cycle model only)
- (5) Do not place animals and plants in the path of the warm air.
- (6) Take the weight of the air conditioner into account and select a place where noise and vibration are small.
- (7) Select a place where the warm air and noise from the air conditioner do not disturb neighbors.
- (8) Provide the space shown in Fig.2 so that the air flow is not blocked. Also for efficient operation, leave open three of the four directions front, rear, and both sides.

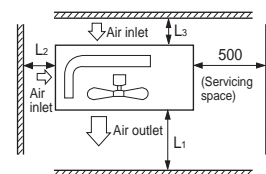

Series	14,18,28			36,42		
	I	II	III	I	II	III
Case Distance						
L <sub>1</sub>	open	open	500	open	open	500
L <sub>2</sub>	300	0	open	300	0	open
L <sub>3</sub>	100	150	100	150	300	150

# INSTALLATION INSTRUCTIONS

Fig. 1

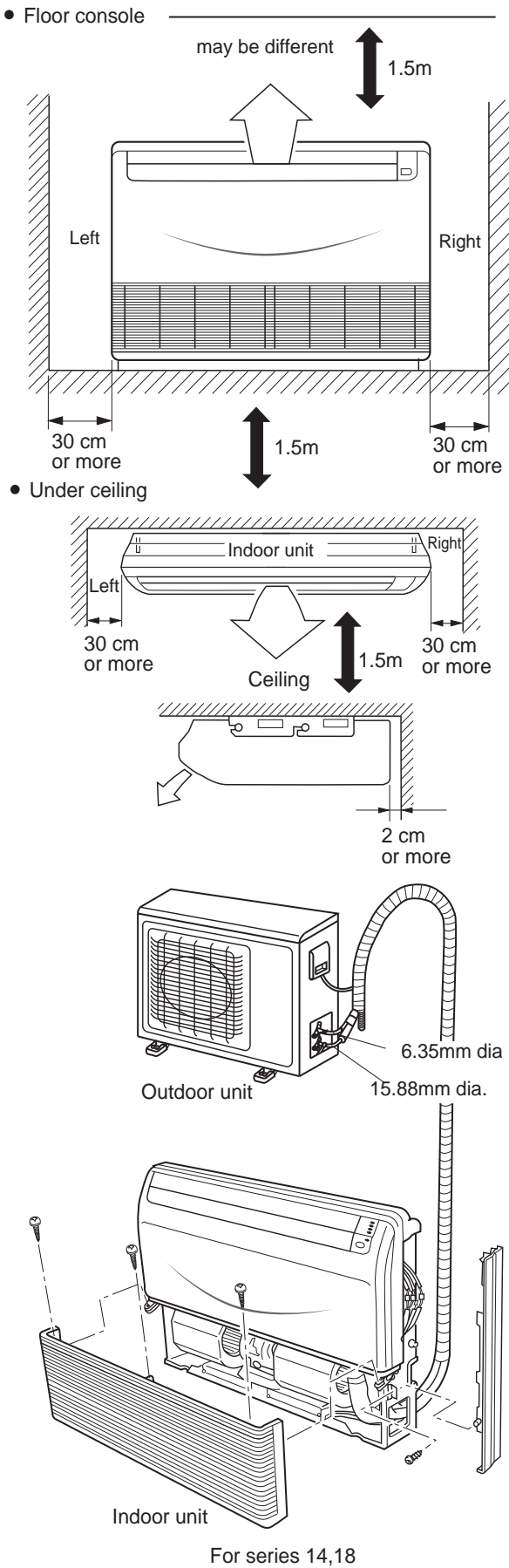
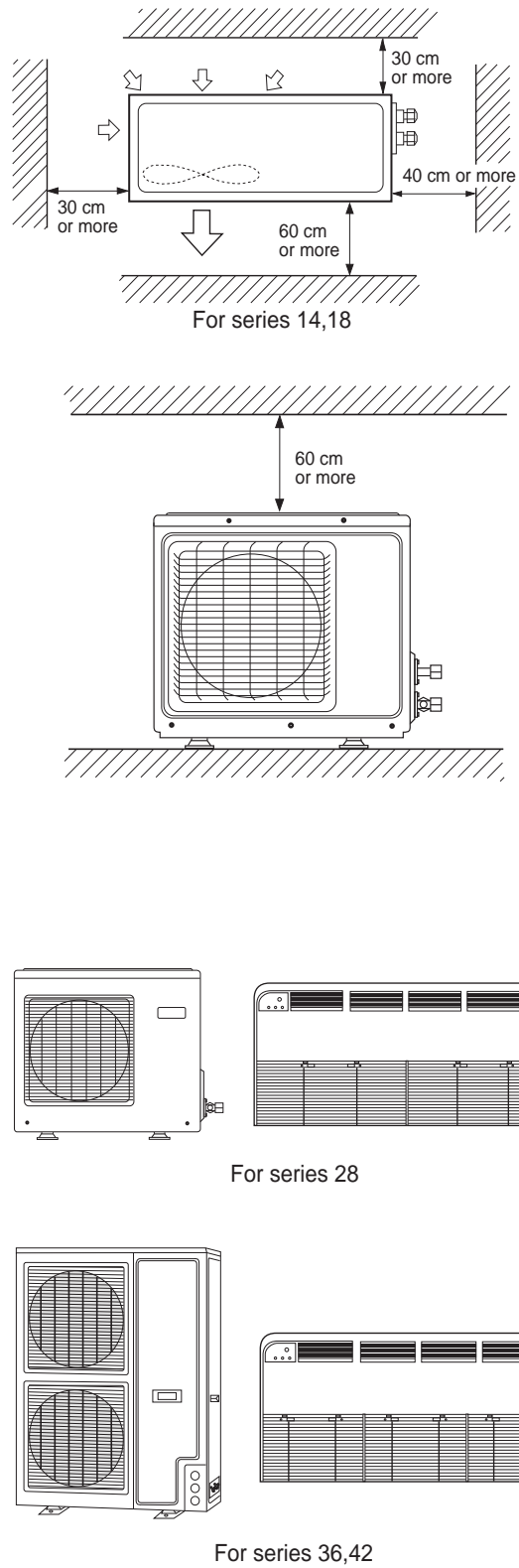

Fig. 2











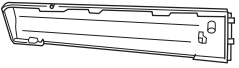
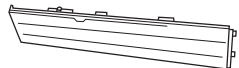

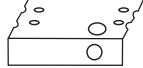
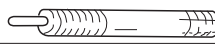



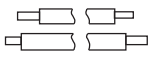
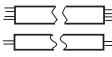

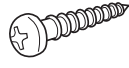

Note: For series 36, 42 no floor console type, the function below about floor console is invalid to the series.

## STANDARD PARTS

The following installation parts are furnished.  
Use them as required.

### ACCESSORIES

Name and shape	Q'ty	Application
Cover plate (left) 	1	For series 24,28, 36,42 the two cover plate are not available
Cover plate (right) 	1	
Tapping screw (∅ 4x10) 	2	
Installation template 	1	For positioning the indoor unit For under ceiling type.
Anchor bolt 	4	For suspending the indoor unit from ceiling
Spring washer 	4	
Special nut 	4	
Pipe hole cover 	1	
Wall hole cover 	1	
Main pipes 	1	
Connecting cables 	1	
Cushion 	4	
Drain-elbow 	1	Only for the heat pump type
Wall bracket 	2	For suspending the indoor unit on the wall. For series 28,36,42 no this part.

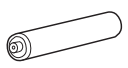
Name and shape	Q'ty	Application
Tapping screw (∅4x20) 	6	For fixing the wall bracket. For series 24,28,36,42 no this part.
Coupler heat insulator(large) 	1	For indoor side pipe joint (Large pipe)
Coupler heat insulator(small) 	1	For indoor side pipe joint (Small pipe)
Nylon fastener 	1	For fixing the drain hose
Drain hose 	1	
Non-adhesive tape 	1	
VT wire 	1	For fixing the drain hose L 280mm For series 24,28,36,42 VT wire is not available
Remote controller 	1	Use for air conditioner operation
Battery 	2	For remote controller unit

#### Optional parts

Mark	Parts name
(A)	Adhesive tape
(B)	Saddle (L.S) with screws
(C)	Connecting electric cable for indoor and outdoor
(D)	Drain hose
(E)	Heat insulation material
(F)	Piping hole cover
(G)	Putty
(H)	Plastic clamp

## CONNECTION PIPE REQUIREMENT

Table 1

Series	Diameter		Maximum length	Maximum height (between indoor and outdoor)
	Liquid side	Gas side		
14,18	6.35 mm	15.88 mm	15 m	5 m
28	9.52 mm	15.88 mm	30 m	15 m
36,42	9.52 mm	19.05mm	50 m	15 m

## INSTALLATION PROCEDURE

Install the room air conditioner as follows:

### PREPARING INDOOR UNIT INSTALLATION

#### 1. REMOVE THE INTAKE GRILL

Open the intake grill and remove the three or four or six screws.

(Fig. 3)

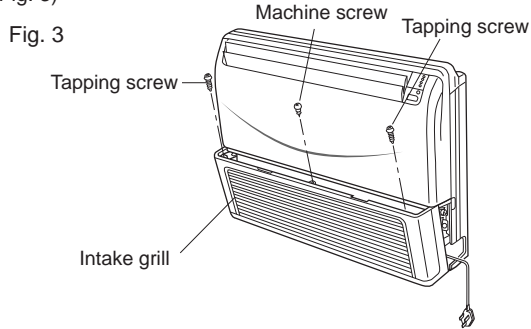

Remark: The main unit can be wired before the indoor unit is installed. Select the most appropriate installation order.

For series 24,28,36,42 not the power plug, but 3-core connecting cable.

#### A. FLOOR CONSOLE TYPE (For series 36,42 no this type)

##### 1. DRILLING FOR PIPING

Select piping and drain directions.(Fig.4) (For series 14,18)

The piping and drain can be made in three directions as shown below.For series 24,28,36,42 can be made rear and down two directions.

(Fig. 4)

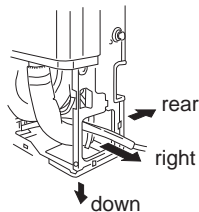

The drain hose can be connected to either the left or right side.(Fig.5)  
For series 24,28,36,42 only right side.

(Fig. 5)

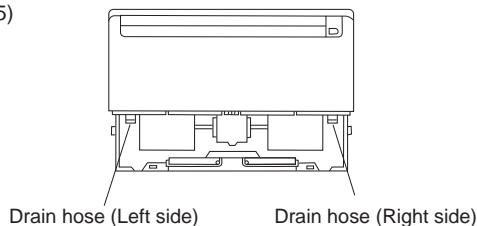

When the directions are selected, drill a 7 cm dia. hole on the wall so that the hole is tilted downward toward the outdoor for smooth water flow. When the pipe is led out from the rear, make a hole in Fig.6, at the position shown.

(Fig. 6)

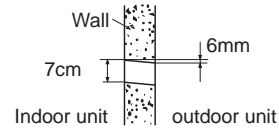

For series 14,18 when installing set to wall, install the accessory wall bracket at the position shown in Fig.7, and mount the set to it.

(Fig. 7)

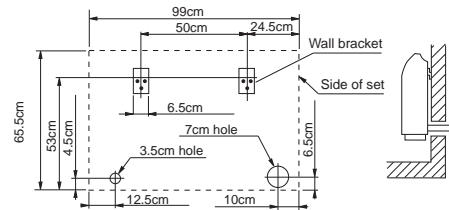

#### INSTALL THE DRAIN HOSE

##### 2. INSTALLING DRAIN HOSE

Select whether the drain hose will be connected to the left or right side.(for series 24,28,36,42 only the right side).(Fig.5)  
Insert the drain hose into the drain pan, then secure the drain hose with a nylon fastener. (Fig.8)

(Fig. 8)

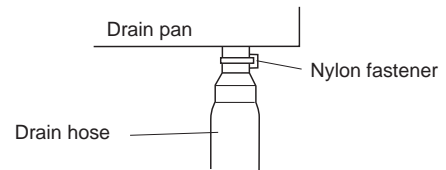

Wrap the insulation (drain hose) around the drain hose connection.(Fig.9)

(Fig. 9)

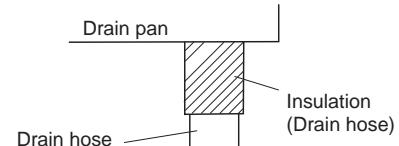

Be sure to arrange the drain hose correctly so that it is leveled lower than the drain hose connecting port of the indoor unit.

Fig. 10

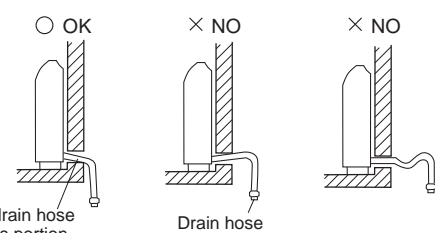

Arrange the drain hose lower than this portion.

### CAUTION

Do not install the unit drain hose side is too high. Height A should be less than 5 mm.(Fig.11)

Fig. 11

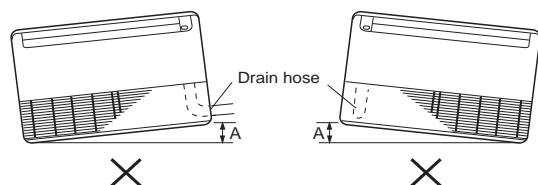

## B. UNDER CEILING TYPE

Using the installation template, drill holes for piping and anchor bolts (for holes). (Fig. 12)

Fig. 12

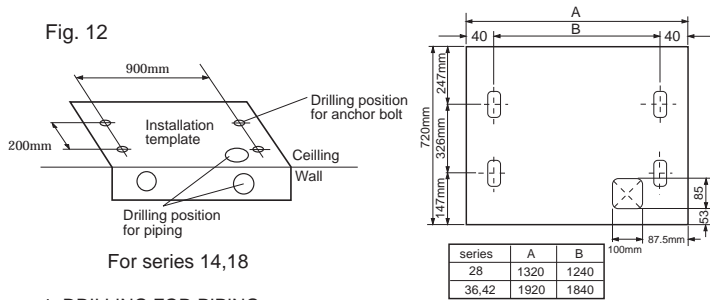

For series 14,18

### 1. DRILLING FOR PIPING

Select piping and drain directions. For series 24,28,36,42 only rear side (Fig. 13)

Fig. 13

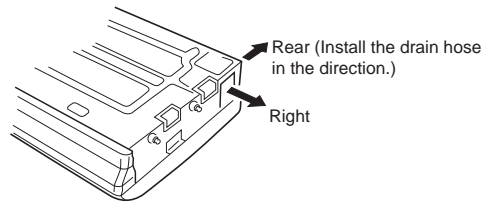

## ⚠ CAUTION

Install the drain hose at the rear; it should not be installed on the top or right side.

When the directions are selected, drill 80mm and 50mm or 150mm dia. hole on the wall so that the hole is tilted downward toward the outdoor for smooth water flow.

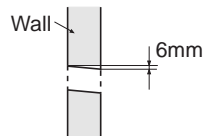

### 2. DRILLING HOLES FOR ANCHOR BOLTS AND INSTALLING THE ANCHOR BOLTS

With a concrete drill, drill four 12.7 mm dia. Holes. (Fig. 15)

Fig. 15

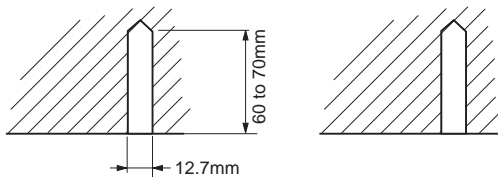

Insert the anchor bolts into the drilled holes, and drive the pins completely into the anchor bolts with a hammer. (Fig. 16)

Fig. 16

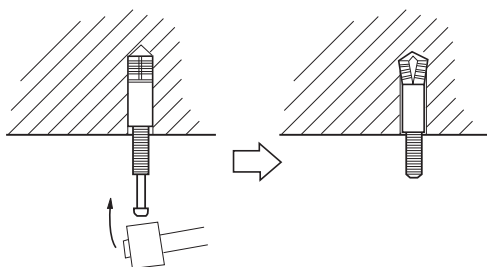

### 3. INSTALLING BRACKETS

Install the brackets with nuts, washers and spring washers. (Fig. 17)

Fig. 17

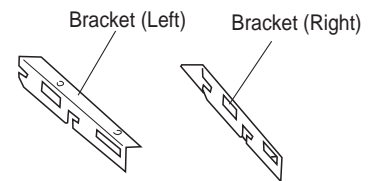
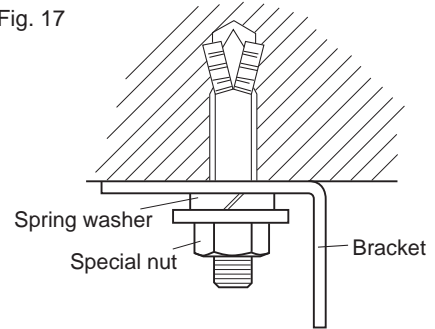

For series 14,18

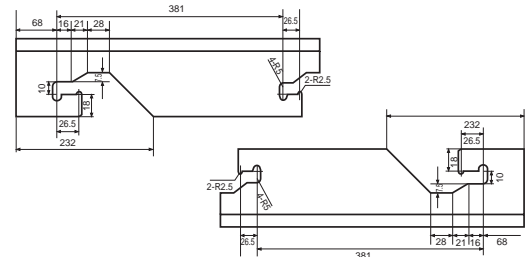

For series 24,28,36,42

### 4. INSTALLING INDOOR UNIT

Reset the hex bolts as shown in Fig. 18.

Fig. 18

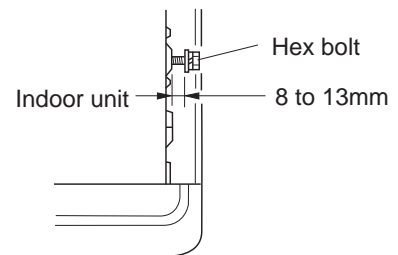

Apply the indoor unit to the brackets. (Fig. 19)

Fig. 19

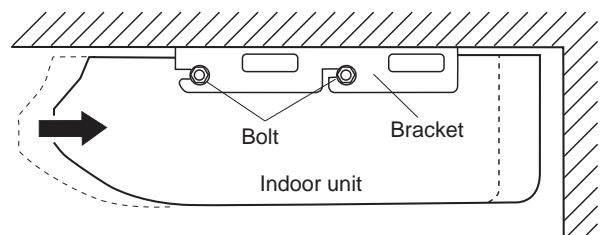

Now, securely tighten the hex bolts in both sides.

## 5. INSTALL THE DRAIN HOSE

Select whether the drain hose will be connected to the left or right side.(Fig.5)

Insert the drain hose into the drain pan, then secure the drain hose with a nylon fastener.(Fig.8)

Wrap the insulation (drain hose)around the drain hose connection. (Fig.9)

Be sure to arrange the drain hose correctly so that it is leveled lower than the drain hose connecting port of the indoor unit.(Fig.20)

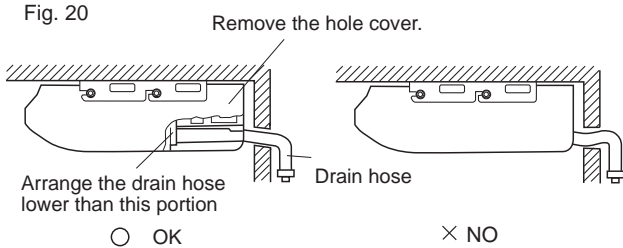

When drain hose is arranged backward.Secure the drain hose with the VT wire. (Fig. 21)

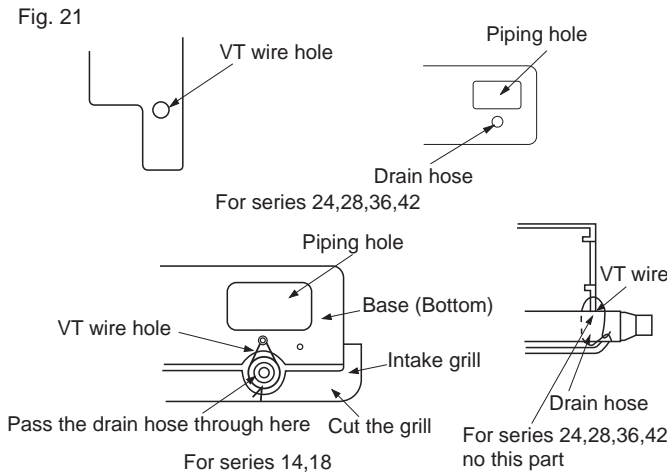

## OUTDOOR UNIT INSTALLATION CONNECTING THE PIPING

### 1. FLARE PROCESSING

- (1) Cut the connection pipe with pipe cutters so that the pipe is not deformed.
- (2) Holding the pipe downward so that cuttings cannot enter the pipe, remove the burrs.
- (3) Remove the flare nut from the indoor unit pipe and outdoor unit and assemble as shown in(Table1) and insert the flare nut onto the pipe, and flare with a flaring tool.
- (4) Check if the flared part "L" (Fig.22)is spread uniformly and that there are no cracks.

Table 1

Pipe	Flare nut
Small pipe	Small (width across flats 22mm)
Large pipe	Large (width across flats 24mm)

Fig. 22

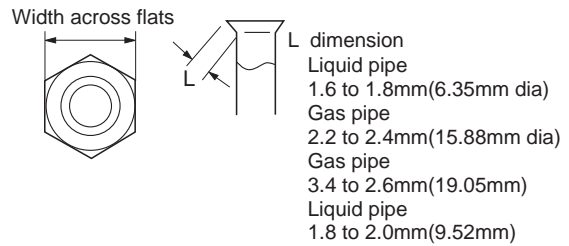

### 2. BENDING PIPES

The pipes are shaped by your hands. Be careful not to collapse them.

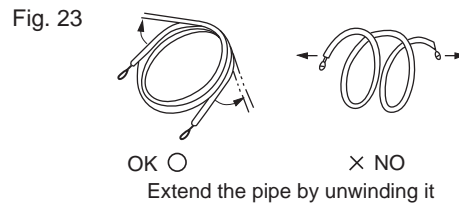

### ⚠ WARNING

BE SURE TO READ THESE INSTRUCTIONS. CAREFULLY BEFORE BEGINNING INSTALLATION. FAILURE TO FOLLOW THESE INSTRUCTIONS COULD CAUSE SERIOUS INJURY OR DEATH, EQUIPMENT MALFUNCTION AND /OR PROPERTY DAMAGE. BE SURE TO READ INSTALLATION MANUAL FOR INDOOR UNIT WITH THIS MANUAL.

### 1. Selection of the place of installation

Select the place of installation satisfying the following conditions and, at the same time, obtain consent from the client or user.

- Place where air circulates.
- Place free from heat radiation from other heat sources.
- Place where drain water may be discharged.
- Place where noise and hot air may not disturb the neighbors.
- Place where there is not heavy snowfall in winter.
- Place where obstacles do not exist near the inlet air port and outlet air port.
- Place where the outlet port may not be exposed to a strong wind.
- Place surrounded at four sides are not suitable for installation.  
A 1m or more of overhead space is needed for the unit.
- Mount guide-louvers to place where short-circuit is a possibility.
- When installing several units, secure sufficient suction space to avoid short circuiting.

### 2. Installation of outdoor unit

#### (1) Installation

Fix the unit in a proper way according to the condition of a place where it is installed by referring to the following.

Fig. 25

#### (a) Concrete foundation(Fig. 25)

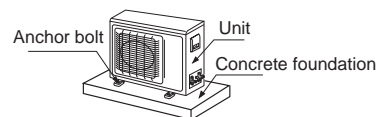

For series 14,18

#### (b) Foundation anchor

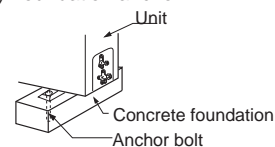
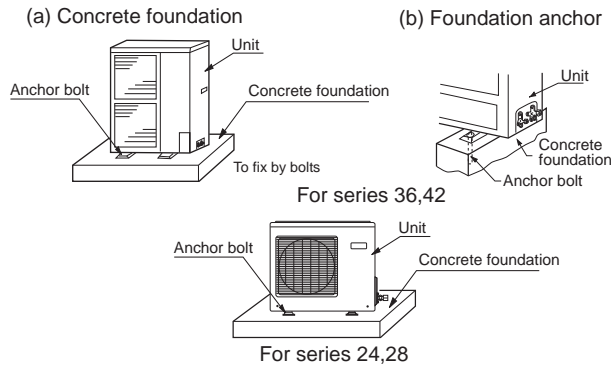

Fig. 25



Note (1) Give enough room for the concrete foundation to fix anchor bolts.

Note (1) Place the concrete foundation deep enough.

- Install the unit so that the angle of inclination must be less than 3 degrees.

### 3. Refrigerant piping

#### (1) Outline of piping

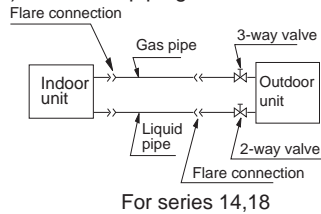

For series 14,18

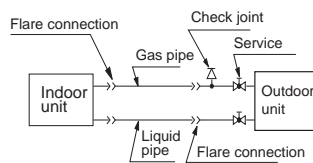

For series 24,28,36, 42

#### (2) Piping size

Series 14,18	Liquid pipe	$\phi$ 6.35x0.8mm
	Gas pipe	$\phi$ 15.88x1.0mm
Series 28	Liquid pipe	$\phi$ 9.52x0.8mm
	Gas pipe	$\phi$ 15.88x1.0mm
Series 36,42	Liquid pipe	$\phi$ 9.52x0.8mm
	Gas pipe	$\phi$ 19.05x1.0mm

- Install the removed flare nuts to the pipes to be connected, then flare the pipes.

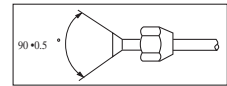

- (3) Limitations for one way piping length and vertical height difference.

- One way piping length: Less than 15 mm
- Vertical height difference: Less than 5 m

(Fig. 26)

#### Precautions for refrigerant piping

- Do not twist or crush piping.
- Be sure that no dust is mixed in piping.
- Bend piping with as wide angle as possible.
- Keep insulating both gas and liquid piping.
- Check flare-connected area for gas leakage.

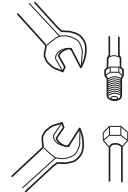

#### (4) Piping connection (Fig.26)

- Connecting method  
Apply refrigerant oil at half union as large and flare nut. To bend a pipe, give the roundness as possible not to crush the pipe. When connecting pipe, hold the pipe centre to centre then screw nut on by hand, refer to Fig. Be careful not to let foreign matters, such as sands enter the pipe.

Forced fastening without centering may damage the threads and cause a gas leakage.

Pipe dia	Fastening torque
Liquid pipe 6.35mm	18N·m
Gas pipe 15.88mm	60N·m
Liquid pipe 9.52mm	40N·m
Gas pipe 19.05mm	110N·m

#### (5) Purging method ( the refrigerant is R407C )

To use vacuum pump

① Detach the service port's cap of 3-way valve, the valve rod's cap for 2-way valve and 3-way's, connect the service port into the projection of charge hose (low) for gaugemanifold. Then connect the projection of charge hose (center) for gaugemanifold into vacuum pump.

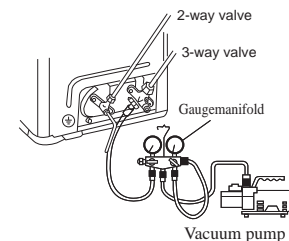
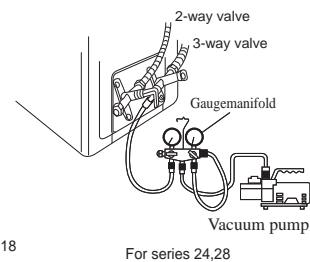
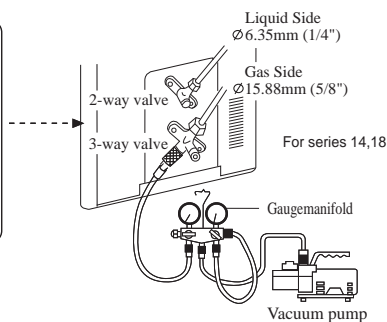

For series 36,42

# INSTALLATION INSTRUCTIONS

② Open the handle at low in gaugemanifold, operate vacuum pump. If the scale-moves of gauge (low) reach vacuum condition in a moment, check ① again.

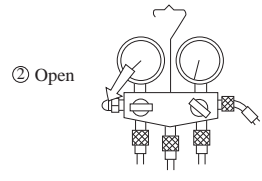

③ Vacuumize for over 15min. And check the level gauge which should read -0.1 MPa (-76 cm Hg) at low pressure side. After the completion of vacuumizing, close the handle 'Lo' in gaugemanifold and stop the operation of the vacuum pump. Check the condition of the scale and hold it for 1-2min. If the scale-moves back in spite of tightening, make flaring work again, the return to the beginning of ③.

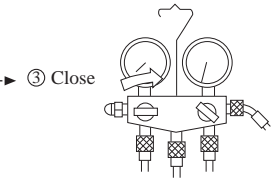

④ Open the valve rod for the 2-way valve to an angle of anticlockwise 90 degree. After 6 seconds later, close the 2-way valve and make the inspection of gas leakage.

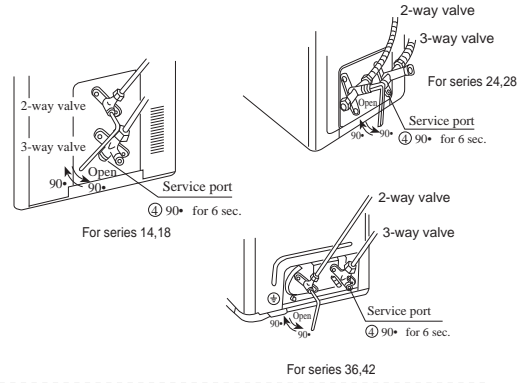

⑤ No gas leakage?

In case of gas leakage, tighten parts of pipe connection. If leakage stops, then proceed ⑥ steps.

If it does not stop gas leakage, discharge whole refrigerants from the service port. After flaring work again and vacuumize, fill up prescribed refrigerant from the gas cylinder.

⑥ Detach the charge hose from the service port, open 2-way valve and 3-way. Turn the valve rod anticlockwise until hitting lightly.

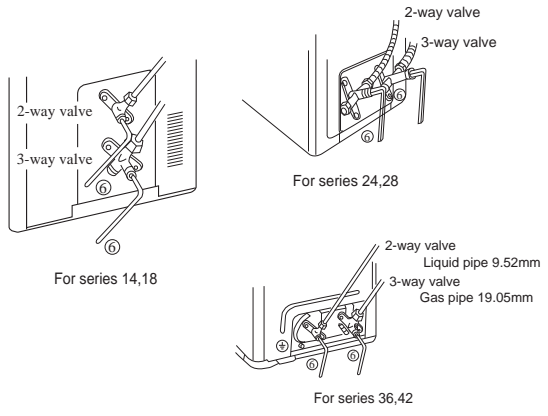

⑦ To prevent the gas leakage, turn the service port's cap, the valve rod's cap for 2-way valve and 3-way's a little more than the point where the torque increases suddenly.

⑧ After attaching the each caps, check the gas leakage around the caps.

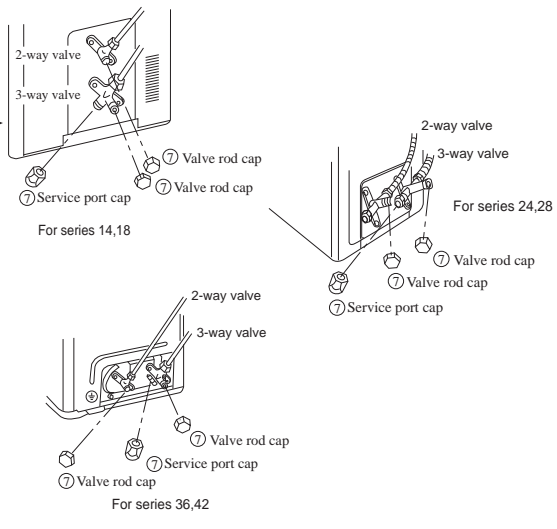

**CAUTION:**  
If the refrigerant of the air conditioner leaks, it is necessary to make all the refrigerant out, then charge the liquid refrigerant into air conditioner according to the amount marked on the name plate.



If needing to remove the refrigerant gas when installation or repair , please refer to the following procedures:

1. Cut off the power
2. (After confirming the power is cut off) pull the power cable plug terminals of the low-pressure pressure-switch out.
3. (After confirming the power cable terminals of the low-pressure pressure-switch is cut off) After powering on the unit again and switch to COOLING mode,perform refrigerant gas removing according to the normal refrigerant gas removing procedure.
4. After finishing refrigerant gas removing , cut off the power , then insert the power cable terminals of the low-pressure pressure-switch properly.

## GAS LEAKAGE INSPECTION

### ⚠ CAUTION

After connecting the piping, check the joints for gas leakage with gas leakage detector.

## HOW TO CONNECT WIRING TO THE TERMINALS

### A. For solid core wiring (or F-cable)(Fig.28A)

- (1) Cut the wire with a wire cutter or wire-cutting pliers, then strip the insulation to about 25mm of the exposed solid wire.
- (2) Using a screwdriver, remove the terminal screw(s) on the terminal board.
- (3) Using pliers, bend the solid wire to form a loop suitable for the terminal screw.
- (4) Shape the loop wire properly, place it on the terminal board and tighten securely with the terminal screw using a screw driver.

### B. For strand wiring(Fig.28B)

- (1) Cut the wire with a wire cutter or wire-cutting pliers, then strip the insulation to about 10mm of the exposed strand wiring.
- (2) Using a screwdriver, remove the terminal screw(s) on the terminal board.
- (3) Using a round terminal fastener or pliers, securely clamp a round terminal to each stripped wire end.
- (4) Position the round terminal wire, and replace and tighten the terminal screw using a screw driver.

Fig. 28

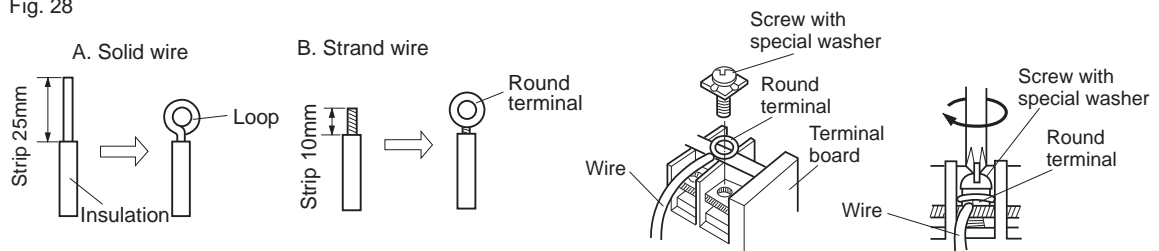

## HOW TO FIXED CONNECTION CORD AND POWER CABLE AT THE CORD CLAMP

After passing the connection cord and power cable through the insulation tube, fasten it with the cord clamp, as shown in Fig.29

Fig. 29

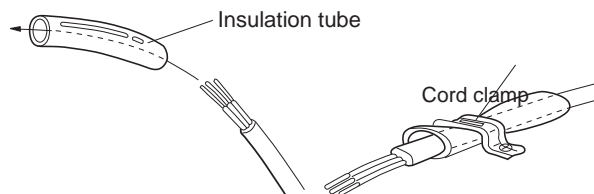

Use VW-1, 0.5 to 1.0 mm thick, PVC tube as the insulation tube.

# INSTALLATION INSTRUCTIONS

## ELECTRICAL REQUIREMENT

- Electric wire size and fuse capacity:

Table 5

Series		14,18		28	36,42
Connection cord (mm <sup>2</sup> )	MAX	3.5	3.5	3.5	3.5
	MIN	2.5	2.5	2.5	2.0
Fuse capacity(A)		20	30	30	30

## ELECTRICAL WIRING

### ⚠ CAUTION

- (1) Match the terminal block numbers and connection cord colors with those of the outdoor unit. Erroneous wiring may cause burning of the electric parts.
- (2) Connect the connection cords firmly to the terminal block. Imperfect installation may cause a fire.
- (3) Always fasten the outside covering of the connection cord with the cord clamp. (If the insulator is chafed, electric leakage may occur.)
- (4) Always connect the ground wire.

### 1. INDOOR UNIT SIDE

- (1) Remove the electric component box.

Fig. 30

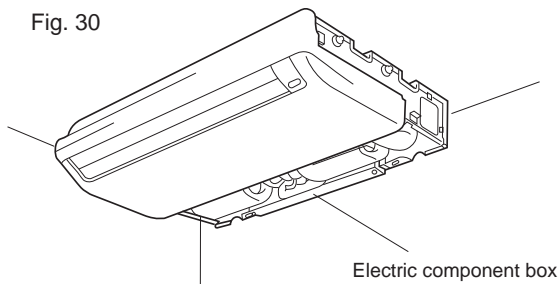

### INDOOR UNIT SIDE

Fig. 31

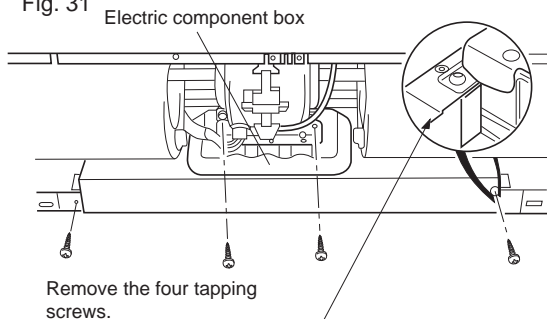

Remove the four tapping screws.

### ⚠ CAUTION

Do not remove the screws. If the screws are removed, the electric component box will fall.

- (2) Pull out the electric component box.

Fig. 32

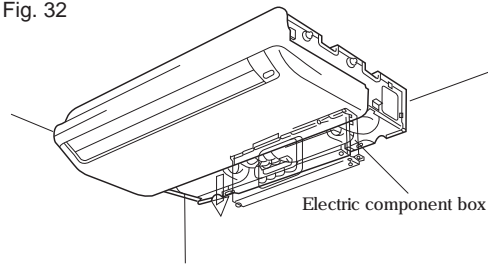

- (3) Remove the electric component box cover.

Fig. 33

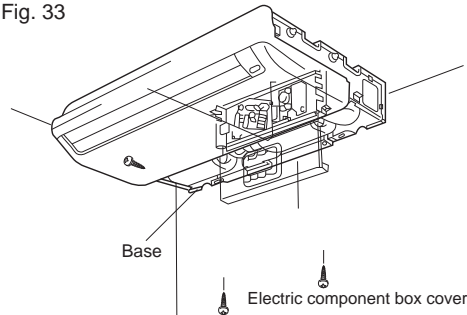

Remove the three tapping screws.

### ⚠ CAUTION

Be careful not to pinch the lead wires between the electric component box and base.

- (4) Wiring

- (1) Remove the cord clamp.
- (2) Process the end of the connection cords to the dimensions shown in Fig.34.
- (3) Connect the end of the connection cord fully into the terminal block.

Fig. 34 Cool model

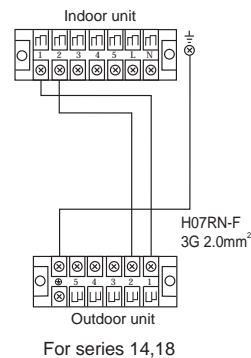

For series 14,18

- (4) Fasten the connection cord with a cord clamp.
- (5) Fasten the end of the connection cord with the screw.
- (6) For series 28,36,42, the power cable and connecting are self-provided.

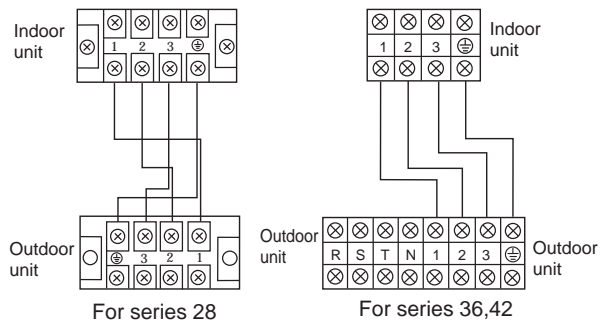

For series 28

For series 36,42

# INSTALLATION INSTRUCTIONS

## ELECTRICAL WIRING

### ⚠ WARNING

- (1) Always use a special branch circuit and install a special receptacle to supply power to the room air conditioner.
- (2) Use a circuit breaker and receptacle matched to the capacity of the room air conditioner.
- (3) The circuit breaker is installed in the permanent wiring. Always use a circuit that can trip all the poles of the wiring and has an isolation distance of at least 3mm between the contacts of each pole.
- (4) Perform wiring work in accordance with standards so that the room air conditioner can be operated safely and positively.
- (5) Install a leakage circuit breaker in accordance with the related laws and regulations and electric company standards.

### ⚠ CAUTION

- (1) The power source capacity must be the sum of the room air conditioner current and the current of other electrical appliances. When the current contracted capacity is insufficient, change the contracted capacity.
- (2) When the voltage is low and the air conditioner is difficult to start, contact the power company the voltage raised.

## TEST RUNNING

### 1. CHECK ITEMS

#### (1) INDOOR UNIT

- (1) Is operation of each button on the remote control unit normal?
- (2) Does each lamp light normally?
- (3) Do not air flow direction louvers operate normally?
- (4) Is the drain normal?

#### (2) OUTDOOR UNIT

- (1) Is there any abnormal noise and vibration during operation?
- (2) Will noise, wind, or drain water from the unit disturb the neighbors?
- (3) Is there any gas leakage?

## CUSTOMER GUIDANCE

Explain the following to the customer in accordance with the operating manual:

- (1) Starting and stopping method, operation switching, temperature adjustment, timer, air flow switching, and other remote control unit operations.
- (2) Air filter removal and cleaning, and how to use air louvers.
- (3) Give the operating and installation manuals to the customer.

## MOUNT THE COVER PLATE AND THE INTAKE GRILL

Note: The following installing procedure only for series 14,18

### 1. Mount the cover plate. (Right)

- (1) Cut a pipe exit hole in the right plate. This is only when the pipe exits from the right side. (This operation is not required when the protrusion is on the top or rear.)

Fig. 35

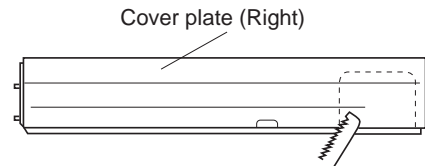

- (2) Join the cover plates (right) and mount with screws.

Fig. 36

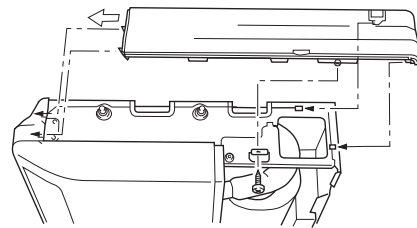

### 2. Mount the cover plate. (Left)

- (1) Join the cover plate (left) and mount with screws.

Fig. 37

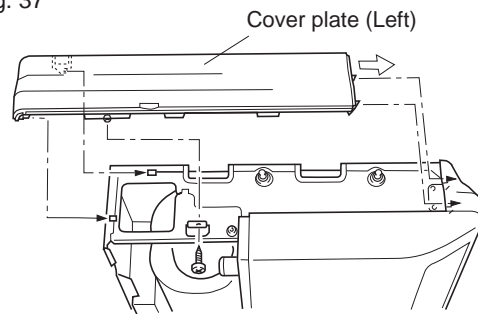

### 3. Mount the intake grill.

- (1) Cut the right side of the intake grill. This is only when the pipe exits from the right side

Fig. 38

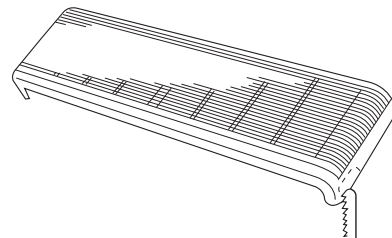

- (2) Insert the hinges on the bottom of the intake grill into the holes in the base assembly. Then mount the arms to the three areas on the top of the intake grill.

Fig. 39

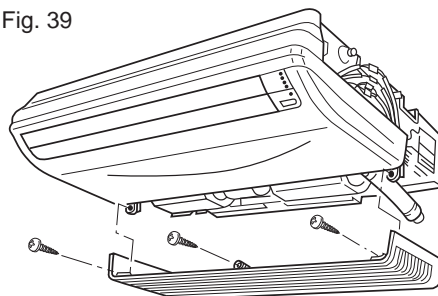

# 6 PARTS AND FUNCTIONS

## 6.1 Drawings

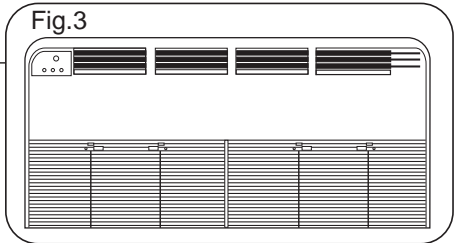
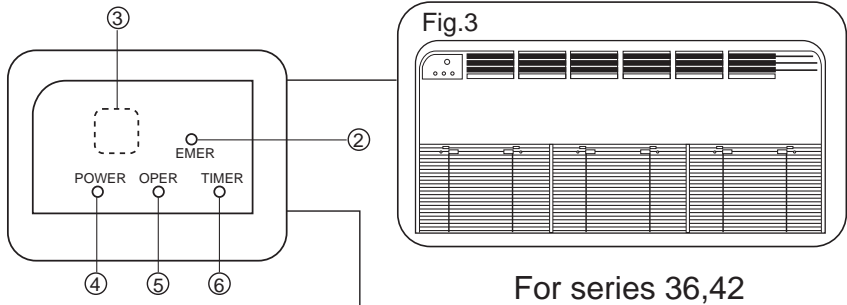
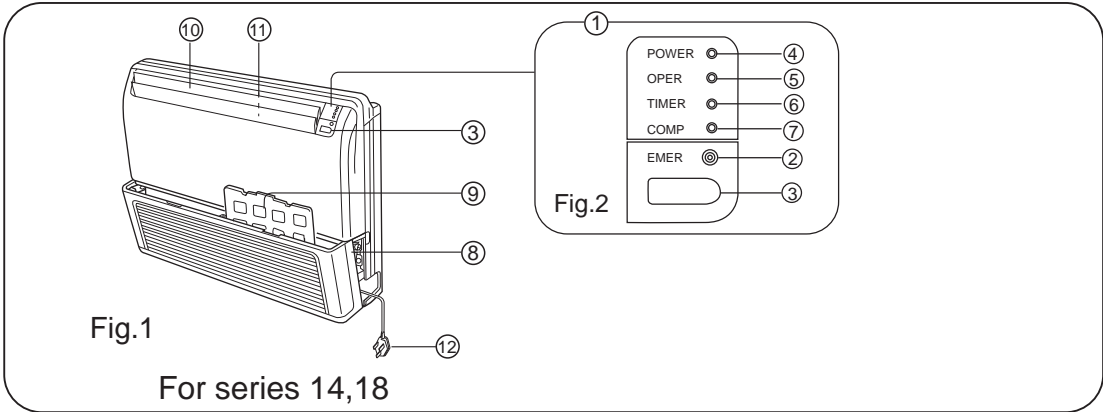
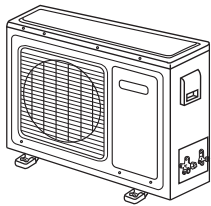
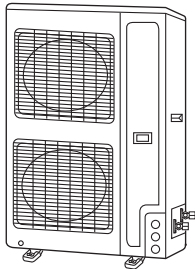

Fig.1 Indoor Unit

- ① Operating Control Panel (Fig.2)
- ② Emergency switch
- ③ Remote Control Signal Receiver
- ④ Power Indicator Lamp (Red)
- ⑤ OPERATION Indicator Lamp (Green)
- ⑥ TIMER Indicator Lamp (Yellow)
- ⑦ Compressor Run Lamp (Green)
- ⑧ Intake Grill (Fig.3)
- ⑨ Air Filter
- ⑩ UP/DOWN Air Direction Flaps
- ⑪ RIGHT/LEFT Air Direction Louvers (behind UP/DOWN Air Direction Flaps)
- ⑫ Power Plug



For series 28



For series 36,42

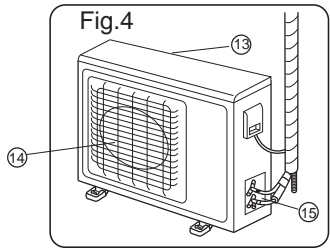

For series 14,18

Fig.4 Outdoor Unit

- ⑬ Intake grill
- ⑭ Outlet grill
- ⑮ Pipe Unit

## 7 REMOTE CONTROLLER FUNCTIONS

### INTRODUCTION TO SPARE PARTS

Buttons and display of the remote controller.

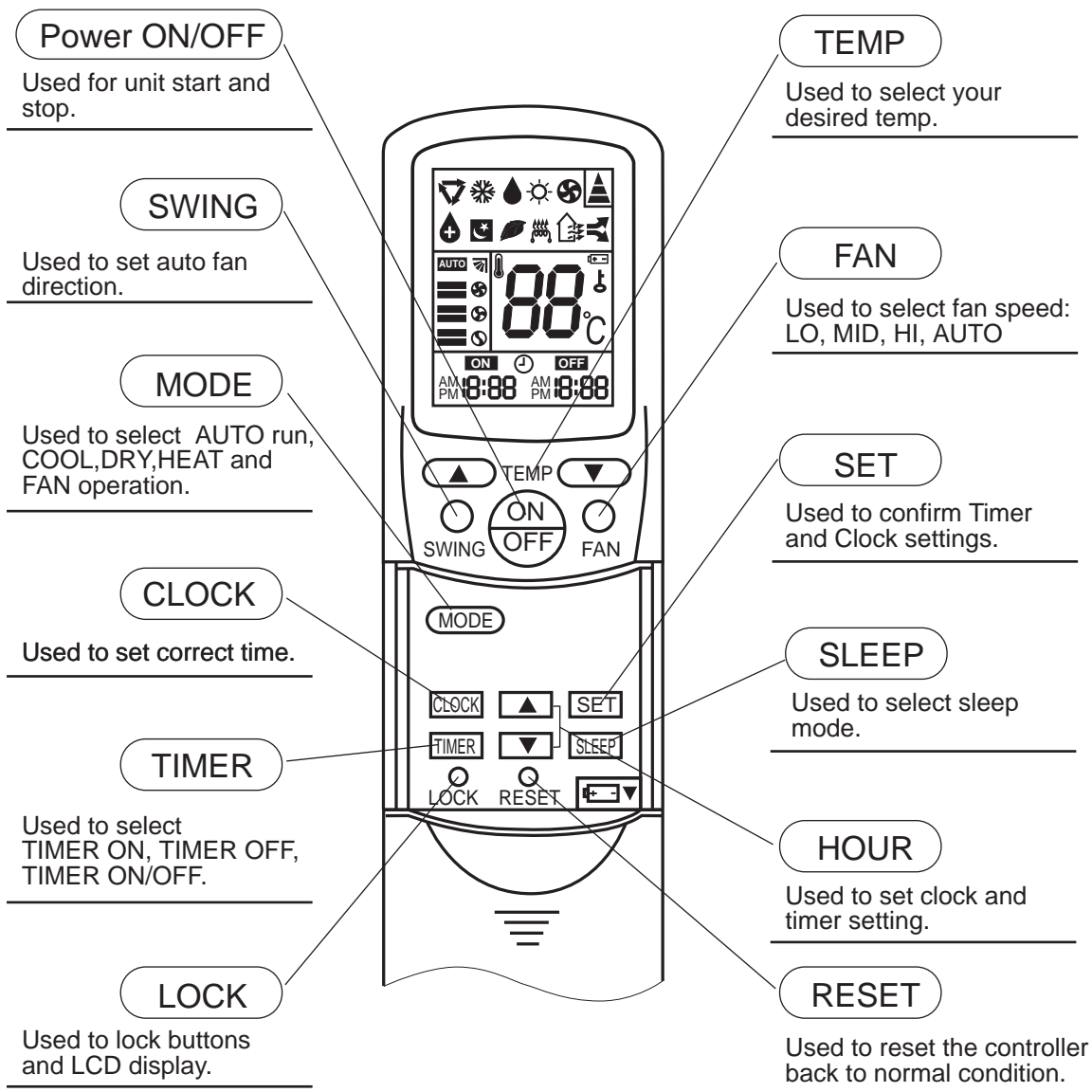

**Cautions:**

On cooling only unit, heating mode is not available.  
After replacing batteries, press ON/OFF, and display becomes as follows:  
Operation mode: AUTO, Temp: 24°C  
Timer mode: No, Fan speed: AUTO

**Note:**

1. The above information is the explanation of the displayed information therefore varies with those displayed in actual operation.
2. This type only has the relevant function and display as indicated in the above figure.

## INTRODUCTION TO SPARE PARTS

Buttons and display of the remote controller.

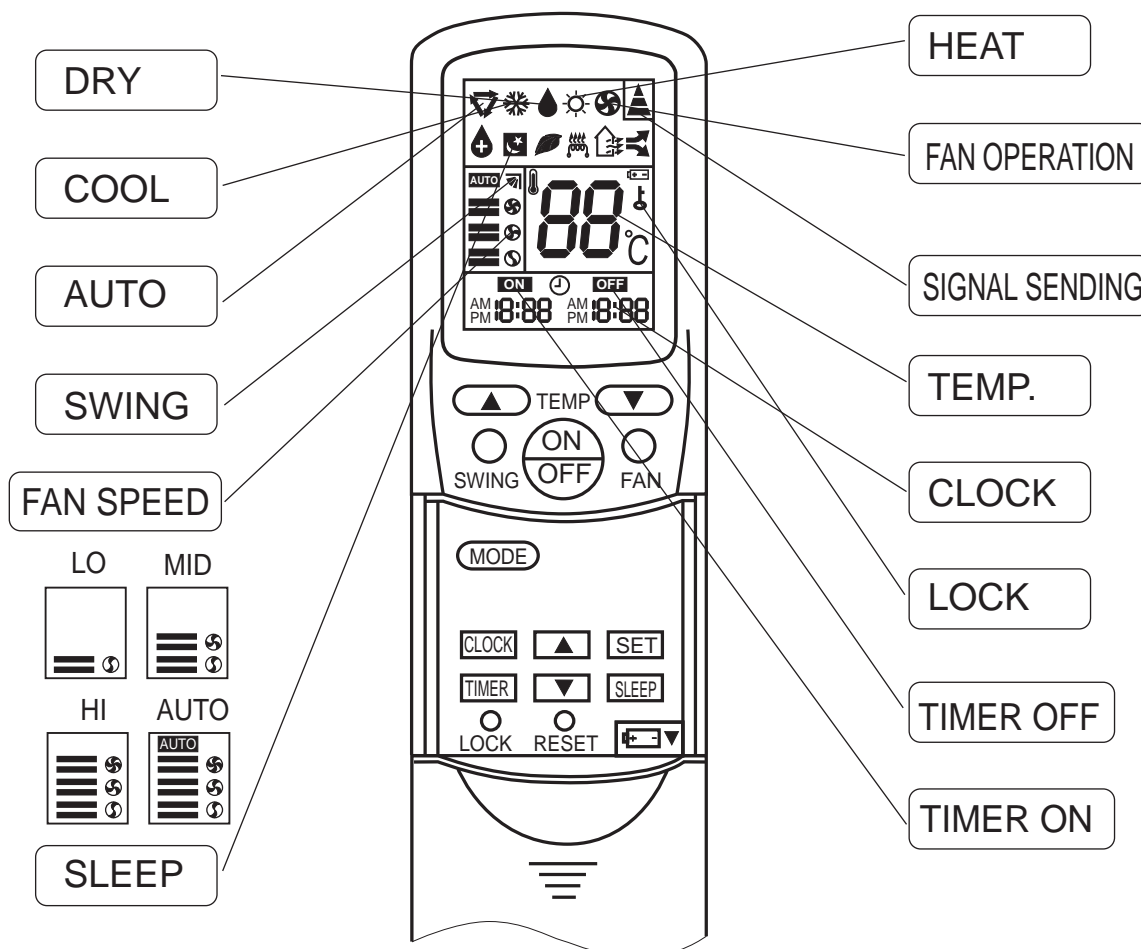

### Clock set

When unit is started for the first time and after replacing batteries in remote controller, clock should be adjusted as follows:

Press **CLOCK** button, "AM" or "PM" flashes.

Press **▲** or **▼** to set correct time. Each press will increase or decrease 1min. If the button is kept depressed, time will change quickly.

After time setting is confirmed, press **SET**, "AM" and "PM" stop flashing, while clock starts working.

### Hints

After replacing with new batteries, remote controller will conduct self-check, displaying all information on LCD. Then, it will become normal.

## REMOTE CONTROLLER OPERATION

### Remote controller's operation

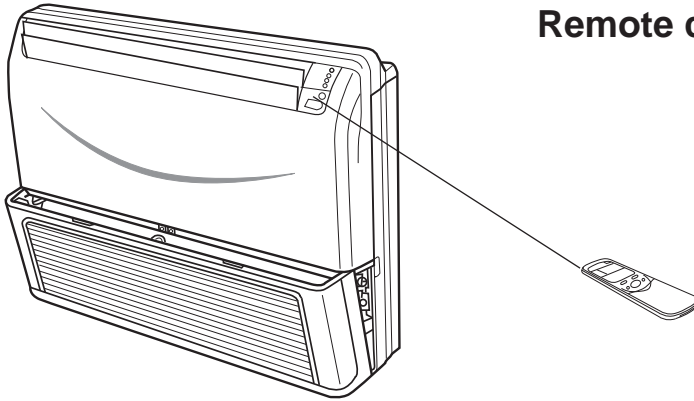

- When in use, put the signal transmission head directly to the receiver hole on the indoor unit.
- The distance between the signal transmission head and the receiver hole should be within 7m without any obstacle as well.
- Don't throw the controller, prevent it from being damaged.
- When electronic-started type fluorescent lamp or change-over type fluorescent lamp or wireless telephone is installed in the room, the receiver is apt to be disturbed in receiving the signals so the distance to the indoor unit should be shorter.

### Loading of the battery

Load the batteries as illustrated.  
2R-03 batteries, resetting key (cylinder)

### Remove the battery cover :

Slightly press "▼" and push down the cover.

### Load the battery :

Be sure that the loading is in line with the " + " / " - " pole request as illustrated.

### Put on the cover again

### Confirmation indicator :

In disordered, reload the batteries or load the new batteries after 5mins.

### Note :

Use two new same-typed batteries when loading.  
If the remote controller can't run normally or doesn't work at all, use a sharp pointed item to press the reset key.

**Hint :** Remove the batteries in case unit won't be in usage for a long period.  
If there is any display after taking-out just need to press reset key.

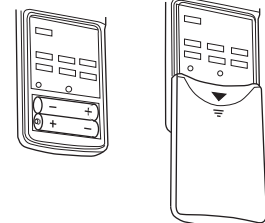
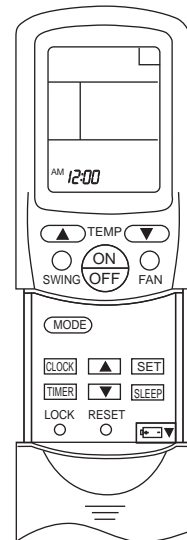

## GUIDE TO OPERATION

### FAN operation

#### (1) Unit start

Press ON/OFF button, unit starts.  
 Previous operation status appears on display.  
 (Not Timer setting)  
 Power indicator on indoor unit lights up.

#### (2) Select operation mode

Press MODE button. For each press, operation mode changes as follows:



Unit will run in selected mode.  
 stop display at " FAN " FAN.

#### (3) Fan

Press FAN button. For each press, fan speed changes as follows:



Unit will run at selected fan speed.  
 Adjust air flow direction if necessary, refer to page13.

#### (4) Unit stop

Press ON/OFF button.  
 Only time remains on LCD.  
 All indicators on indoor unit go out.  
 Vertical flap closed automatically.

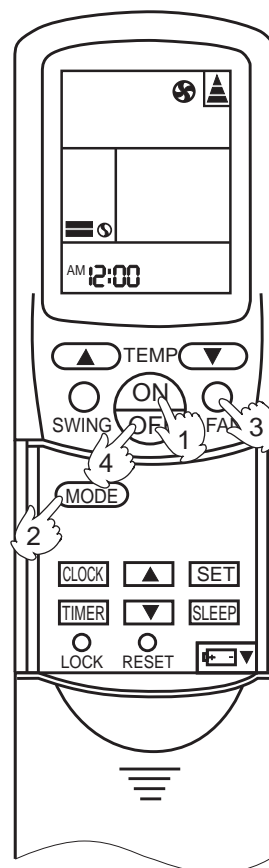

#### Hints

Remote controller can memorize settings in each operation mode. To run it next time just select the operation mode and it will start with the previous setting.  
 No reselecting is needed.(TIMER ON/OFF needs reselecting)



## GUIDE TO OPERATION

### AUTO run, COOL,HEAT and DRY operation

#### Recommendations

- Use COOL in summer.
- Use HEAT in winter.
- Use DRY in spring,autumn and in damp climate.

#### (1) Unit start

Press ON/OFF button, unit starts.

Previous operation status appears on display.(Not Timer setting)

Power indicator on indoor unit lights up.

#### (2) Select operation mode

Press MODE button. For each press, operation mode changes as follows:



Unit will run in operation mode displayed on LCD.

Stop display at your desired mode.

#### (3) Select temp.setting

Press TEMP button

▲ Every time the button is pressed, temp. setting increases 1°C

▼ Every time the button is pressed, temp. setting decreases 1°C

Unit will start running to reach the temp. setting on LCD.

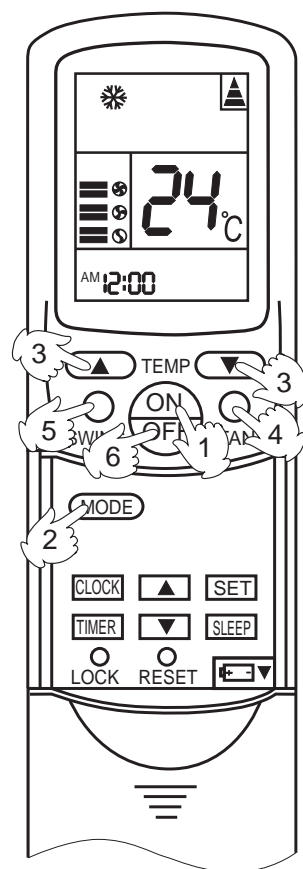

#### Hints

Remote controller can memorize each operation status. When starting it next time, just press ON/OFF button and unit will run in previous status.

## GUIDE TO OPERATION

### (4) Fan speed selection

Press FAN button. For each press, fan speed changes as follows:



Unit runs at the speed displayed on LCD.

In HEAT mode, warm air will blow out after a short period of time due to cold-draft prevention function.

In DRY mode, when room temp. becomes 2°C higher than temp. setting, unit will run intermittently at LO speed regardless of FAN setting.

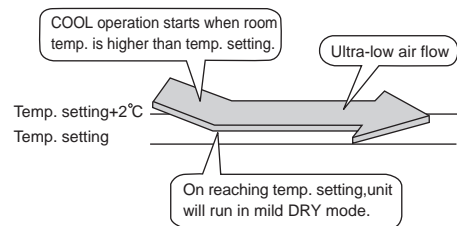

### (5) Air flow direction adjust

After operation mode is selected, vertical flap will open automatically according to the mode.

### (6) Unit stop

Press ON/OFF button.

Only time remains on LCD.

All indicators on indoor unit go out.

Vertical flap closes automatically.

#### Hints

As cold air flows downward in COOL mode, adjusting air flow horizontally will be much more helpful for a better air circulation.

As warm air flows upward in HEAT mode, adjusting air flow downward will be much more helpful for a better air circulation.

Be careful not to catch a cold when cold air blows downward.

It is harmful to your health in summer to go frequently in and out of places where temp. difference is above 7°C. Temp. difference of 3-5°C will remove your fatigue.

More than this, unit's load can be reduced and power consumption cut down as well. So, you'd better set a temp. diff of 3-5°C between indoor and outdoor temp. in COOL mode.

## GUIDE TO OPERATION

### TIMER operation

Set Clock correctly before starting Timer operation(refer to page 6)

You can let unit start or stop automatically at following times: Before you wake up in the morning, or get back from outside or after you fall asleep at night.

### TIMER ON/OFF

(1)After unit start, select your desired operation mode.

Operation mode will be displayed on LCD.

Power indicator on indoor unit lights up.

#### (2)TIMER mode selection

Press TIMER button to change TIMER mode.

Every time the button is pressed, display changes as follows:



Select your desired TIMER mode (TIMER ON or TIMER OFF) ON or OFF will flash.

#### (3)Timer setting

Press HOUR ▲/▼ button.

▲Every time the button is pressed, time increases 10min. If button is kept depressed, time will change quickly.

▼Every time the button is pressed, time decreases 10min. If button is kept depressed, time will change quickly. Time will be shown on LCD. It can be adjusted within 24hours.

#### (4)Confirming your setting

After setting correct time, press SET button to confirm "ON" or "OFF" stops flashing

Time displayed: Unit starts or stops at x hour x min (TIMER ON or TIMER OFF).

Timer mode indicator on indoor unit lights up.

### To cancel TIMER mode

Just press TIMER button several times until TIMER mode disappears.

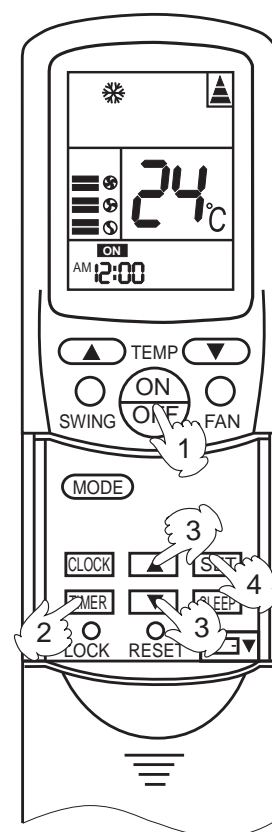

#### Hints

After replacing batteries or a power failure happens, Time setting should be reset. Remote controller possesses memory function, when use TIMER mode next time, just press SET button after mode selecting if timer setting is the same as previous one.

## GUIDE TO OPERATION

### TIMER ON-OFF

(1)After unit start, select your desired operation mode

Operation mode will be displayed on LCD.

Power indicator on indoor unit lights up.

(2)Press TIMER button to change TIMER mode

Every time the button is pressed, display changes as follows:



Select TIMER ON-OFF, "ON" will flash.

(3)Time setting for TIMER ON

Press HOUR button.

▲ Every time the button is pressed, time increases 10min.

If button is kept depressed, time will change quickly.

▼ Every time the button is pressed, time decreases 10min.

If button is kept depressed, time will change quickly. Time will be shown on LCD.

It can be adjusted within 24hours.

AM refers to morning and PM to afternoon.

(4)Time confirming for TIMER ON

After time setting, press TIMER button to confirm.

"ON" stops blinking, While "OFF" starts blinking.

Time displayed: Unit starts at X hour X min.

(5)Time confirming for TIMER OFF

Follow the same procedures in "Time setting for TIMER ON".

(6)Time setting for TIMER OFF

After time setting, press SET button to confirm "OFF" stops flashing.

Time displayed: Unit stops at X hour X min.

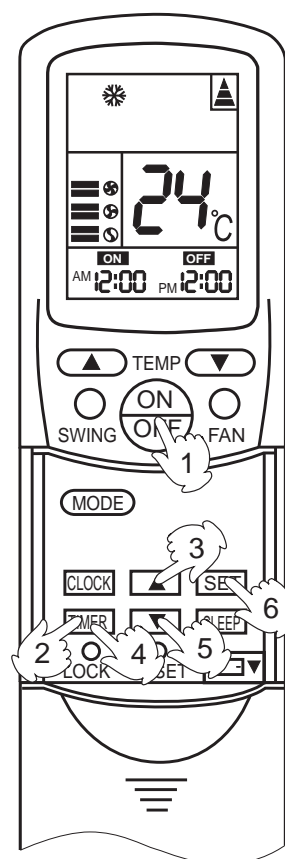

### To cancel TIMER mode

- Just press TIMER button several times until TIMER mode disappears.
- According to the Time setting sequence of TIMER ON or TIMER OFF, either Start-Stop or Stop-Start can be achieved.

### AIR FLOW DIRECTION ADJUSTMENT PROCEDURE

#### Adjusting up/down air flow direction

- Up/down direction can be adjusted by using the SWING button on the remote controller.

Each time pressing this button, the mode changes in the following sequence.

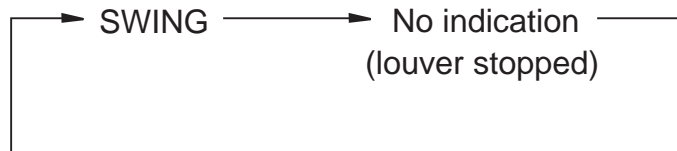

Change to the AIRFLOW mode.

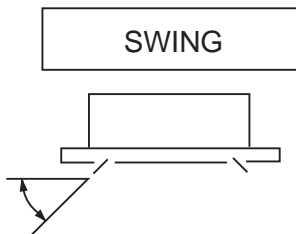

Louver moves in upward and downward directions continuously.

LOUVER STOPPED

When the LOUVER button is pushed during SWING mode, it stops swinging at the just angle.

#### ⚠ CAUTION

- Avoid direct air flow to the body for many hours.
- Avoid downward blowing operation of cooling mode for many hours.
- Do not touch the swing louver during swing operation.

## Comfortable Sleep

At night, before going to bed you can press down the SLEEP button on the controller and the air-conditioner will run by the comfortable sleeping mode to make you sleep more comfortable.

Press SLEEP button once to make the air conditioner have the previous-set sleep time (first power-on is "1h"), the sleep symbol will appear. Press time button▲/▼, you can choose the time in 1~8 hours. Each press of▲/▼, the time increases/reduces 1 hour and "xh" appears in the humidity setting part, "OFF" appears in "TIMER OFF" display part and timer-off time; press SLEEP button again to cancel sleep function, the sleep symbol disappears.

## In cooling, dehumidifying mode

One hour after sleeping operation start, the temp. is 1°C higher than the setting one. After another hour the temp. rises 1°C and then run continuously for another 6hrs' and then close. The actual temp. is higher than the setting one which is to prevent from being too cool to your sleep.

## In heating mode

One hour after start up, the temp. decrease 2°C lower than the setting one. After another hour decrease by more 2°C.

The temperature will automatically rise by 1°C after another 3hrs' operation, and then automatically close after 3hrs' continuous operation. The actual temperature is lower than the setting one which is to prevent from being too hot to your sleep.

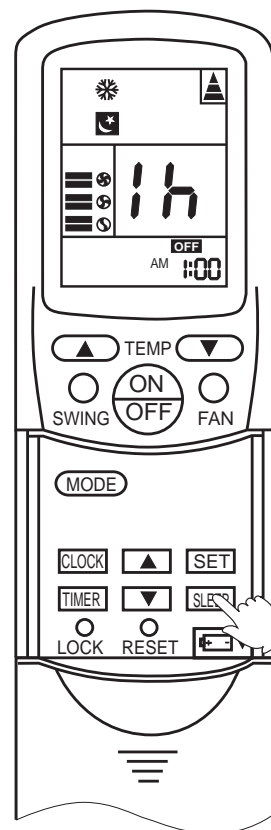

Note:

- In AUTO mode, unit will run in SLEEP function according to the operation mode.
- After setting SLEEP function, it is forbidden to calibrate clock.
- If the set sleep-time does not reach 8 hours, the unit will stop operation automatically after set time is complete.
- Set "TIMER-OFF" function first, then set SLEEP, and press the sleep-set-performance; set TIMER-ON function first, the sleep function can only be set before TIMER-ON; if set the SLEEP function first, the TIMER function can not be set.
- After setting SLEEP, press CLOCK button to show the time; press TEMP. button to show the temperature; press again to change temperature.
- When the set SLEEP time is 8 hours, connect it as shown in the following figure.

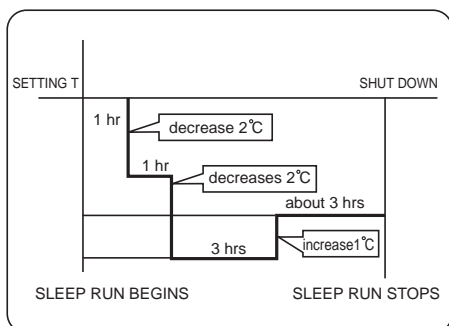

Heat mode

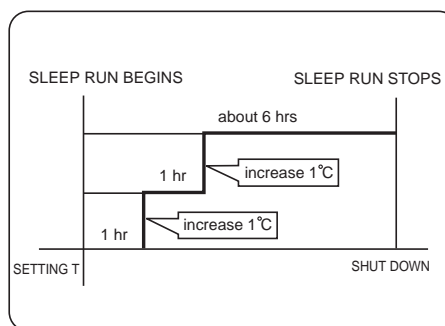

Cooling mode

### **Remote Control:**

There is a telecommunication interface for remote control on the control panel of the indoor unit. After the peripheral equipment have been installed in accordance with the instruction manual of the selected remote control detector, the air conditioner will be computerized and controlled from a far-away place.

### **Power Failure Resume (to be applied for a necessary situation):**

After the power failure compensation is set, if power failure suddenly occurs while the air conditioner is working, it will resume the previous working state when the power is supplied again.

**Setting Method:** When the remote controller is on (excluding timer mode and fan mode), press the "Sleeping" button on the remote controller 10 times within 5 seconds, and after the buzzer rings 4 times, the air conditioner will enter the state of power failure compensation.

**Cancel Method:** Press the "Sleeping" button on the remote controller 10 times within 5 seconds, and after the buzzer rings 2 times, the power failure compensation mode will be cancelled.

**Notes:** When a power failure suddenly occurs during the air conditioner is working after the power after the power failure compensation is set, if the air conditioner will not be used for a long time, please cut off the power supply to prevent its operation from being resumed after the power is supplied again, or press the "Switch On/Off" button after the power comes again.

# REMOTE CONTROLLER FUNCTIONS & REFRIGERANT DIAGRAM

## 7.2 Dimensions of the controller

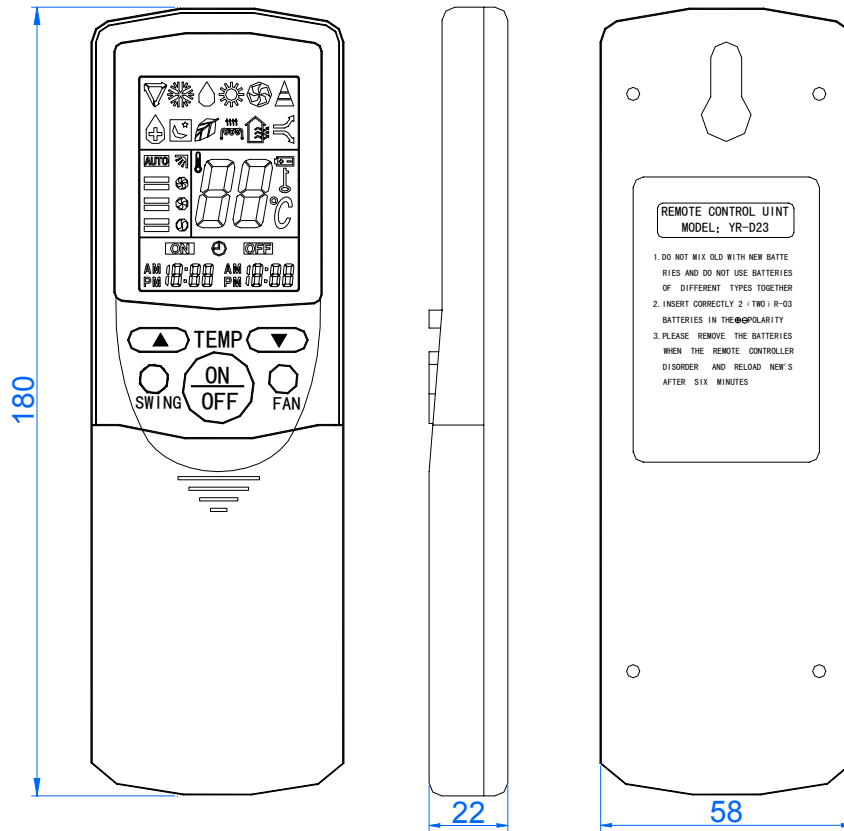

## 8 REFRIGERANT DIAGRAM

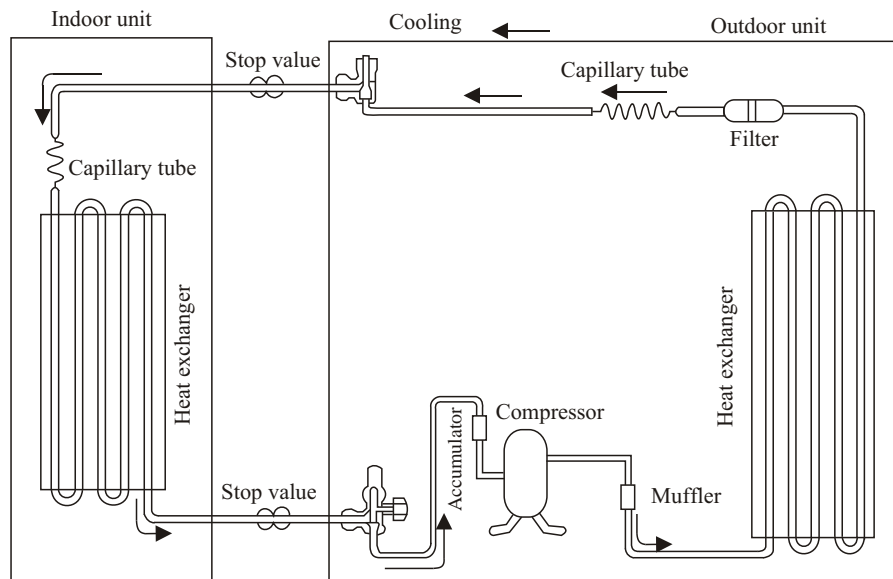



## 9 ELECTRICAL CONTROL FUNCTIONS

### 9.1 Control Features

The brief introduction includes those for each item of various types of air conditioners and their electric control functions.

#### 7.1 Brief introduction of electric control

##### (1) Automatic run

##### a. Cooling-heating type

After the machine being started and running mode changes to AUTO, the system will decide running mode according to difference between the present room temperature and setting temperature, then runs as the decided mode. In the following selections,  $T_r$  means room temperature and  $T_s$  means setting temperature.

Select running mode according to the following conditions at the first time to enter Auto mode:

- $T_r \geq T_s - 3^\circ\text{C}$  to select cooling mode (with setting temperature being  $T_s + 3$ )
- $T_r < T_s - 3^\circ\text{C}$  to select heating mode (with setting temperature being  $T_s$ )

After the system entering auto run mode, the running mode can convert automatically according to variation of room temperature between cooling, blowing and heating in the way shown as the chart below:

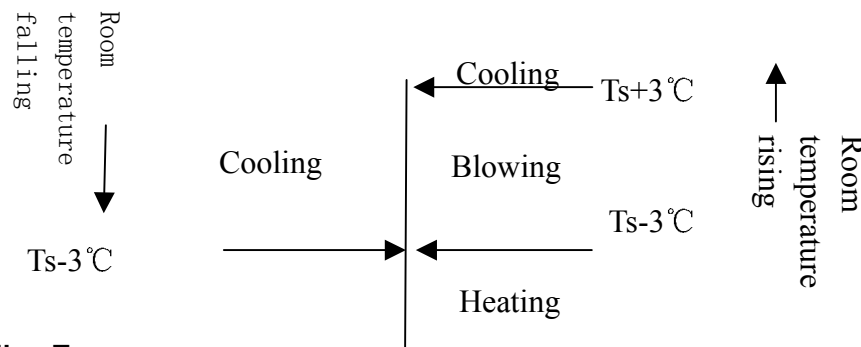

##### b. Single Cooling Type

Select running mode according to the following conditions at the first time to enter Auto mode:

- $T_r \geq T_s + 3^\circ\text{C}$  to select cooling mode
- $T_r < T_s + 3^\circ\text{C}$  to select blowing mode

After the system entering auto run, the running mode can convert automatically according to variation of room temperature between cooling and blowing functions in the way shown as the chart below:

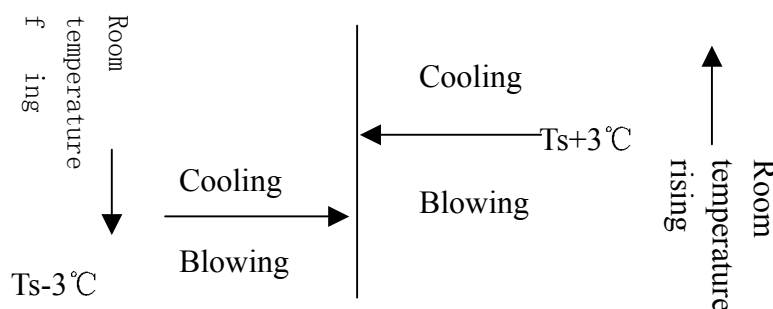

(2) Auto Selection of Wind Speed

In the following,  $T_r$  means room temperature while  $T_s$  means setting temperature.

**a. During cooling program**, conversion of wind speed from the low to high won't work until the present speed has continued for 3 minutes while conversion from the high to low needs no time delay. The chart below is the sketch map of conversion:

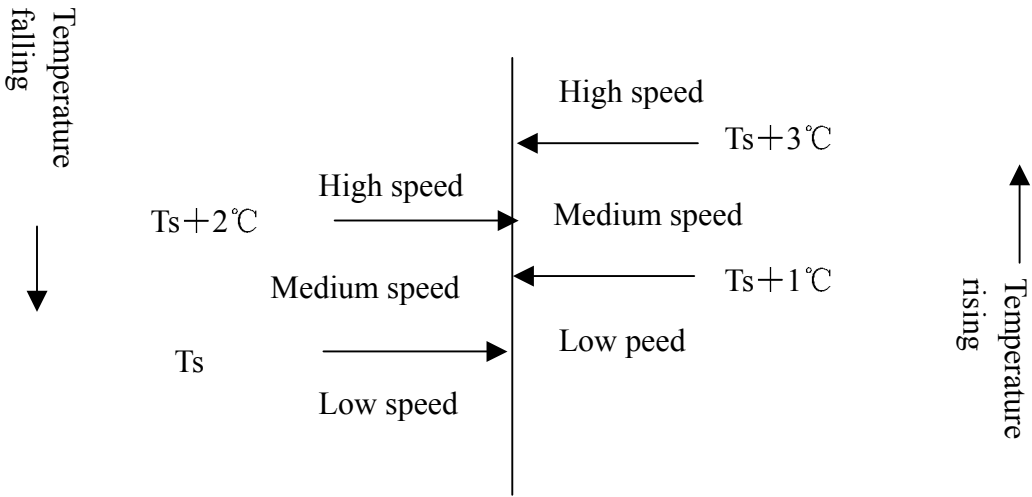

**b. During heating program** (applicable for cooling-heating type), conversion of wind speed from the low to high won't work until the present speed has continued for 3 minutes while conversion from the high to low needs no time delay. The chart below is the sketch map of conversion:

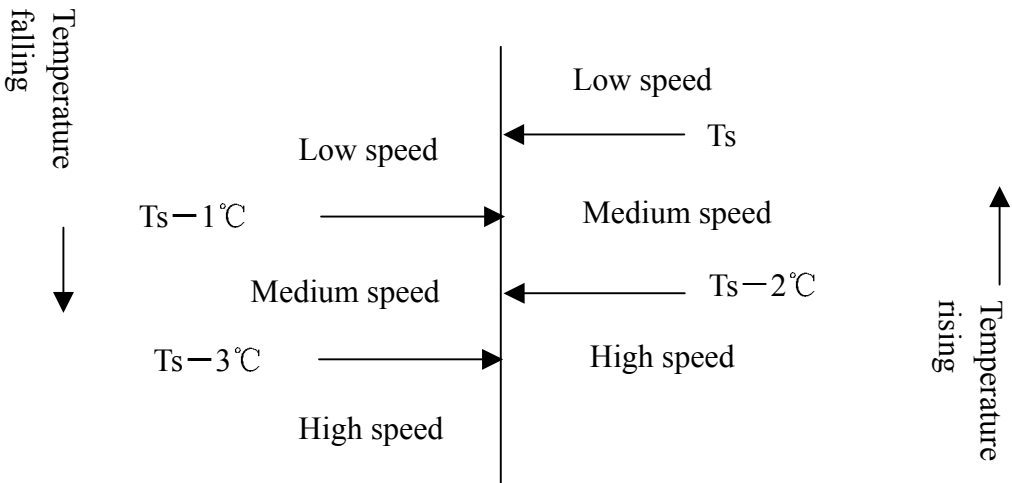

(3) Dehumidifying program

In the following,  $T_r$  means room temperature while  $T_s$  means setting temperature.

a. After the system entering dehumidifying program, the compressor, outdoor and indoor blowing fans run according to the following rules:

(1)  $T_r > T_s + 2^\circ\text{C}$ , the compressor and outdoor blowing fan run continuously while indoor

blowing fan runs at setting wind speed. This working area is defined as area A.

- (2)  $T_s \leq T_r \leq T_s + 2^\circ\text{C}$ , the compressor and outdoor blowing fan run for 10 minutes then pause for 6 minutes, while indoor blowing fan runs at low wind speed. This working area is defined as area B.
- (3)  $T_r < T_s$ , the compressor and outdoor blowing fan stop working while outdoor blowing fan runs at low wind speed. This working area is defined as area C.

a. After dehumidifying program starting, the system converts between A, B and C areas according to variations of room temperature with running mode being shown as the chart below:

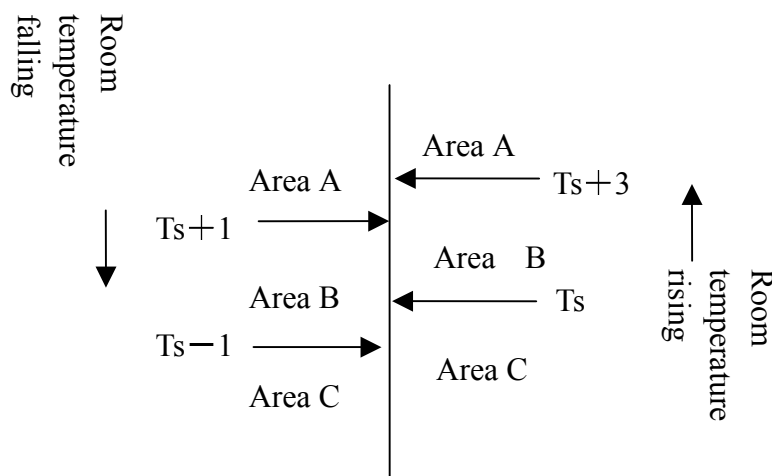

#### (4) Cutoff protection against overload and overheat

During heating program, if the indoor blowing fan has been started and the compressor has been running more than 2 minutes, and the **temperature of indoor coil pipe (Ticp)**  $> 64^\circ\text{C}$ , the outdoor blowing fan will stop running; If  $Ticp \leq 50^\circ\text{C}$  and the outdoor blowing fan has kept stop state for 45 seconds, then it will restore rotation; If  $Ticp > 67^\circ\text{C}$  and such temperature has last for 10 seconds, the compressor will stop running and indoor blowing fan run according to conditions as it reaches setting temperature. When  $Ticp < 58^\circ\text{C}$ , and the compressor has kept stop state over 3 minutes, then the compressor and outdoor blowing fan will restore normal running.

#### Cutoff protection for heating current

After 60 seconds from the compressor being started, if CT current exceeds I1 (9.2A) and such case has kept 5 seconds, the outdoor blowing fan will stop. If 45 seconds has passed after the outdoor blowing stops and the current of the compressor is less than I2 (7.5A), the blowing fan will restore running. If CT current exceeds I3 (14.3A) and such case lasts for 3 seconds, the compressor and outdoor blowing fan will stop. The compressor will not restore running until 3 minutes passes with CT current less than 12A.

#### (5) Cool wind prevention during heating program

At the first time entering heating program or after ending the latest frost removal, if the **temperature of indoor coil pipe (Ticp)**  $< 28^\circ\text{C}$ , the indoor blowing fan will stop running; If  $28^\circ\text{C} \leq Ticp < 38^\circ\text{C}$ , the indoor blowing fan will run at low speed; If  $Ticp > 38^\circ\text{C}$  or the compressor has been running for more than 4 minutes, the indoor blowing fan will run at

setting wind speed.

(6) Afterheat blowing during heating program

During heating program, the compressor will stop running (except overheat protection or frost removal) while the indoor blowing fan will firstly run for 50 seconds at low speed then stop.

(7) Frost removal control (applicable for cooling-heating type)

(1) Starting conditions for frost removal:

- A. The indoor unit is in overload protection and outdoor blowing fan stops. The outdoor blowing fan does not enter overheat mode in 10 minutes after it is restarted, the compressor has run over 45 minutes totally while 20 minutes continuously, and the temperature of indoor coil pipe is lower than 43°C;
- B. After the compressor continuously running for 20 minutes, the temperature of indoor coil pipe falls 1°C every 6 minutes and such case continuously appears three times, and the temperature of indoor coil pipe is less than 40°C, and 5 minutes have passed after the compressor is restarted;
- C. The compressor has run totally over 3 hours while 20 minutes continuously, and the temperature of indoor coil pipe is less than 40°C;
- D. The difference between room temperature and the one of indoor coil pipe is less than 16°C and the compressor has totally run over 45 minutes while 20 minutes continuously;

Frost removal will start if any one of the above conditions is satisfied.

(2) Ending conditions for frost removal:

- 1) Time of frost removal has exceeded 9 minutes;
- 2) CT current exceeds I<sub>4</sub>(8.2A);

(3) Actions of each load after the frost removal starts:

The compressor and outdoor blowing fan stop, and indoor blowing fan also stops. 55 seconds later the reversal valve is closed and next 5 seconds later the compressor is started.

(4) Actions of each load after the frost removal ends:

The compressor stops running while outdoor blowing fan immediately runs at high speed, 55 seconds later the reversal valve is opened and next 5 seconds later the compressor restores running and indoor blowing fan runs as conditions for cool wind prevention.

(8) Freeze protection

After the compressor has run for 9 minutes, the system will check **temperature of indoor coil pipe (Ticp)**. If Ticp is less than -1°C, the compressor and outdoor blowing fan will stop. They will run again after the compressor stops if both the following conditions are satisfied:

- 1) 3 minutes have passed since compressor stops.
- 2) Ticp exceeds 7°C.

(9) 3 minutes protection for compressor

After compressor stops, it cannot be started until 3 minutes later. During the machine's running, if time after losing power not exceeds 3 minutes, the compressor cannot be

restarted until 3 minutes later after it is reenergized.

### (10) Power breakdown memory

If the machine suddenly loses power while running, or stops for maintenance or trouble shooting, it will restart running as the status when it stops after the power is restored.

Note: 1. Function setting: Continuously press sleep button on the remote controller 10 times in 5 seconds and buzzer on control panel shall beep 4 times.

2. Memory content: Running mode, wind speed setting, temperature setting, swing status.

3. Cancel: Press sleep button on the remote controller 10 times and buzzer on control panel beeps 2 times.

### (11) Control of water pump

a. In cooling (including automatic cooling mode) and dehumidifying modes, the water pump works if the compressor runs while stops 5 minutes later after the compressor stops.

b. When water tank is fully filled, the float switch will be off. The water pump will start to work after a controller has detected this signal and it will continue working for 5 minutes after the float restores to normal state.

c. If the full water signal is detected continuously over 5 minutes, the water pump indicator lamp will flash to alarm and compressor stops running. The water pump will run 5 minutes, then pause for 5 seconds before next 5 minutes' running, ... until the float restores to normal state, after which the pump will run for 5 minutes then stop.

### (12) Monitoring of remote network

Through preset interface, the air conditioner is connected to remote control detector (made by Haier) with 2-core cables for wire communication, to execute instructions sent from computer or centralized controller via remote control detector and meanwhile send present running status and trouble information of the machine to remote control detector.

Connection between air conditioner and remote control detector:

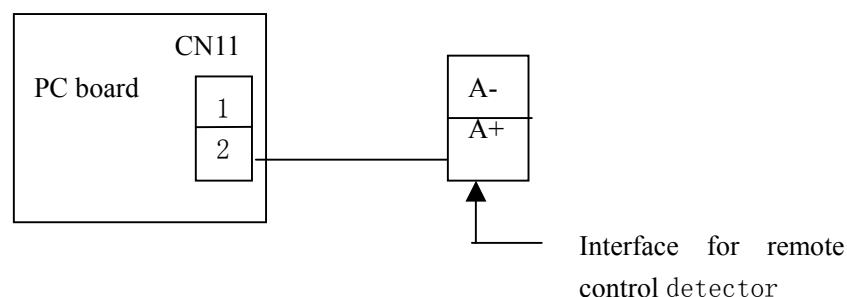

### (13) Trial run

Under shut-down state, hold pressing mandatory button. The buzzer will beep once, then twice after 5 seconds. Release the button to enter mandatory cooling mode, under which the indoor blowing fan runs at high speed with both the compressor and outdoor blowing fan working. Press the mandatory button again can end the mandatory mode.

9.3 Defrost operation flow chart

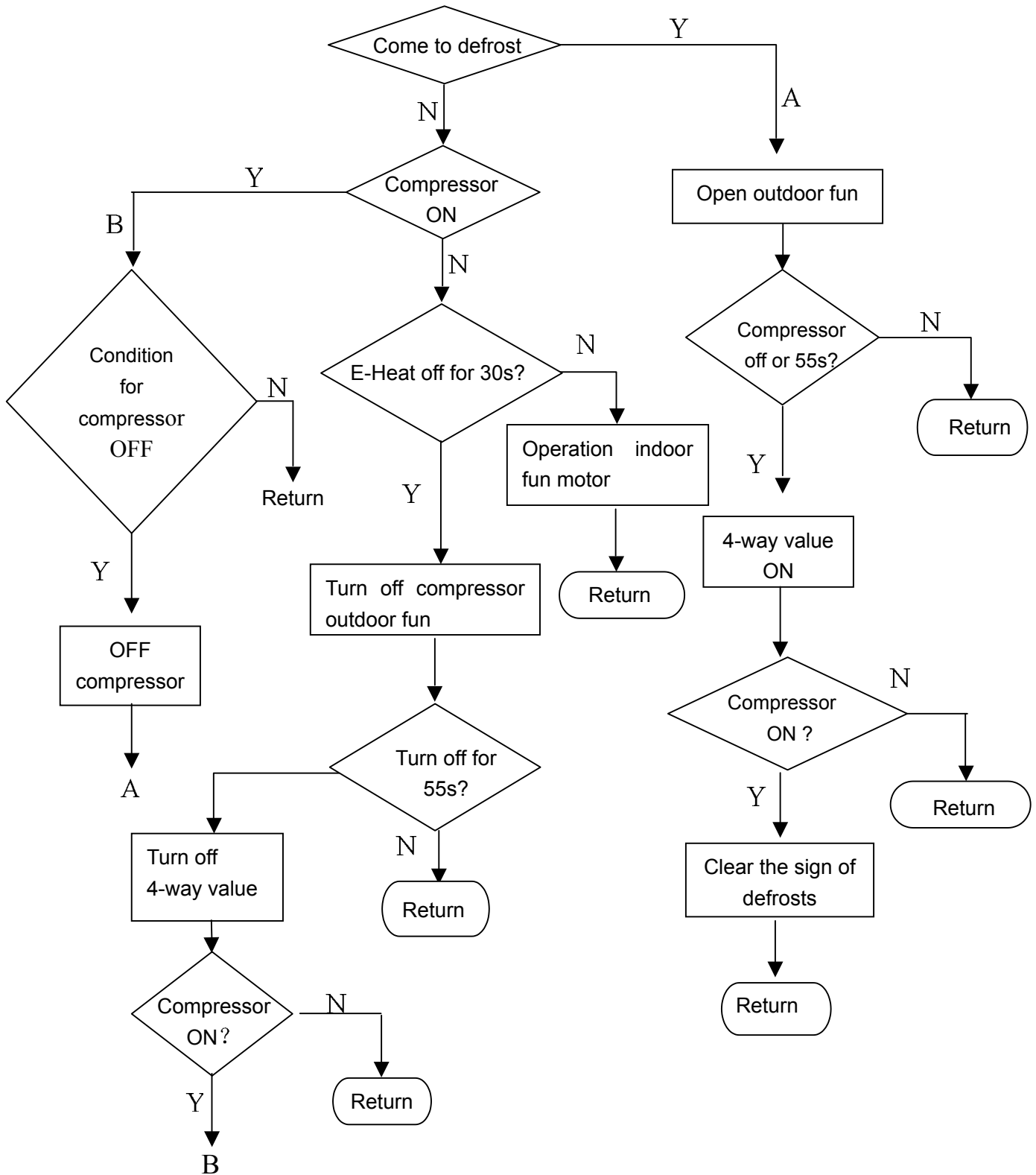

### 10 DIAGNOSTIC INFORMATION (TROUBLE SHOOTING)

#### 10.1 Fault codes

No.	Code	Flash time of compressor running indicate lamp	Trouble contents (new)
1	E0	10	drainage system trouble
2	E1	1	indoor temperature sensor broken
3	E2	2	indoor coil temperature sensor broken
4	E3	3	outdoor temperature sensor broken
5	E4	4	outdoor coil temperature sensor broken
6	E5	5	over current protect limit
7	E6	6	pressure protect
8	E7	7	three phase protect
9	E8	8	Communication trouble between wired remote controller and indoor unit
10	E9	9	communication trouble between indoor and outdoor unit

Indicate lamp of remote control receiver board:

Green----power lamp

Yellow----timer lamp

Red----running of compressor

Red----water pump

The faults are shown by lamp flashing or display on the remote controller

**10.2 Trouble shooting - Detailed for engineer**

<b>Trouble</b>	<b>Checkup result</b>	<b>Possible reasons</b>	<b>Corresponding solution</b>
No response after power being connected	Unavailable voltage at input part of circuit board	The power supply coil isn't plugged well	Plug the supply coil properly
	Unavailable voltage at one end of the fuse	Damaged wave filtering component	Return to the controller manufacturer for repair
	Unavailable output from the consequent pole of transformer	Damaged fuse	Replace with a good one
	Improper output of 7805	The transformer isn't plugged well or is damaged	Plug the transformer well or replace with a good one
	Normal power supply for major chip	Damaged component on power supply unit of indoor board	Return to the controller manufacturer for repair
		Damaged major chip	Return to the controller manufacturer for repair
Display board does not make normal response	Indicator lamps do not light	Damaged connection cable between display board and indoor board	Replace with a good connection cable
		Connection cable between display board and indoor board isn't connected well	Connect the cable well
	Remote control cannot be received	Damaged reception adaptor	Replace with a good one
		Damaged remote circuit or major chip	Return to the controller manufacturer for repair
The buzzer does not beep while making remote control	Unavailable square wave signal at two ends of the buzzer	Damaged dynatron Q1	Replace with a good one
	Available square signal at two ends of the buzzer	Damaged major chip	Return to the controller manufacturer for repair
	No output from 2803 on indoor board	Damaged buzzer	Replace with a good one
Indoor blowing fan does not run	Normal output of relays K1, JK2, JK3	Damaged 2803	Replace with a good 2803
	No output at 16 pin of 2803 on indoor board	CN8 on indoor board is not plugged well with connection cable	Connect connection parts well
Indoor blowing fan cannot generate low wind	Unavailable voltage on COM port of relay JK2 on indoor board	Damaged 2803	Replace with a good 2803
	No output at relay JK1 on indoor board	Damaged relay JK2	Replace with a good one
		Damaged relay JK1	Replace with a good one



## DIAGNOSTIC INFORMATION (TROUBLE SHOOTING)

Trouble	Checkup result	Possible reasons	Corresponding solution
Indoor blowing fan cannot generate medium wind	No output at 15 pin of 2803	Damaged 2803	Replace with a good 2803
	No voltage at COM of relay JK3 on indoor board	Damaged relay JK3	Replace with a good JK3e
Indoor blowing fan cannot generate high wind	No output at relay JK2 on indoor board	Damaged relay JK2	Replace with a good JK2
	No output at 14 pin of 2803	Damaged 2803	Replace with a good 2803
No output of swing	No output at relay JK3 on indoor board	Damaged relay JK3	Replace with a good JK3
	No output at 11 pin of 2803	Damaged 2803	Replace with a good 2803
Unavailable power breakdown memory	No output at relay JK6 of indoor board	Damaged relay JK6	Replace with a good JK6
		No setting has been made	Press sleep button 10 times within 5 seconds (and the buzzer will beep 4 times), the system is then set to power breakdown memory mode.
Unavailable power breakdown memory		Damaged chip IC6 of indoor board	Return to the controller manufacturer for repair
	No output at 18 pin of 2803	Damaged 2803	Replace with a good 2803
No output of four-way valve during heating program	No output of relay JK7 on indoor board	Damaged relay JK7	Replace with a good JK7
	Available output of relay JK7 on indoor board	Socket CN6 is not plugged well with connection cable	Plug CN6 and the connection cable well
No swing wind under swing mode	No output at 12 pin of 2803	Damaged 2803	Replace with a good 2803
	No output of relay JK5 on indoor board	Damaged relay JK5 on indoor board	Replace with a good JK5
	Available output of relay JK5 on indoor board	Socket CN4 is not plugged well with connection cable	Plug CN4 well with the connection cable

## DIAGNOSTIC INFORMATION (TROUBLE SHOOTING)

Trouble	Checkup result	Possible reasons	Corresponding solution
During cooling program, the compressor does not start when the temperature meets proper conditions		Three minutes' protection for compressor	The compressor will work normal after three minutes
		Too low temperature of indoor coil pipe causes overcooling protection	It will restore automatically when the temperature of indoor coil pipe rises to 7°C
	No output at 11 pin of 2803 on indoor board	Damaged 2803	Replace with a good 2803
	No output of relay JK6 on indoor board	Damaged relay JK6 on indoor board	Replace with a good JK6
	No output of relay JK6 on indoor board	Connection cable between the compressor and JK6 isn't plugged well	Plug the connection cable well
		3 minutes' delay protection for compressor	It will restore normally after 3
During heating program, the compressor does not start when the temperature meet proper conditions		Too high temperature of indoor coil pipe causes overheat protection	It will automatically restore when the temperature of indoor coil pipe falls to 57°C
	No output at 11 pin of 2803 of indoor board	Damaged 2803	Replace with a good 2803
	No output of relay JK6 on indoor board	Damaged relay JK6 on indoor board	Replace with a good JK6
During heating program, the compressor does not start when the temperature meet proper conditions	Available output of relay JK6 on indoor board	Connection cable between compressor and JK6 isn't plugged well	Plug the connection cable well
	No output at collector of Q2 on indoor board	Damaged Q2	Replace with a good Q2
	No output of relay JK8 on indoor board	Damaged relay JK8 on indoor board	Replace with a good JK8
During cooling program, the compressor works while outdoor blowing fan does not	Available output of relays on indoor board	Socket CN6 is not plugged well with connection cable	Plug the connection cable well

## DIAGNOSTIC INFORMATION (TROUBLE SHOOTING)

Trouble	Checkup result	Possible reasons	Corresponding solution
During heating program, the compressor work while outdoor blowing fan does not		Too high temperature of indoor coil pipe causes overheat protection	It will automatically restore when the temperature of indoor coil pipe falls to 57°C
During heating program, the compressor work while outdoor blowing fan does not	No output at collector of Q2 on indoor board	Damaged Q2	Replace with a good Q2
	No output of relay JK8 on indoor board	Damaged relay JK8 on indoor board	Replace with a good JK8
	Available output of relays on indoor board	Socket CN6 is not plugged well with connection cable	Plug the connection cable well
Abnormal overcurrent detection	Current transformer outputs normally	Damaged rectification diode D6-D7 etc.	Return to the controller manufacturer for repair
	Transformer CT1 outputs abnormally	Damaged transformer CT1	Replace with a good one
	Inaccurate protection current	Adjust the adjustable potentiometer	
With timing indicator and compressor indicator extinguishing, the operation indicator flashes every second		Damaged major chip	Return to the controller manufacturer for repair
With timing indicator and compressor indicator lighting, the operation indicator flashes every second		Damaged indoor temperature sensor	Replace with a good one
Water pump indicator flashes every second (trouble for water discharging)	No output at 13 pin of 2803 on indoor board	Damaged temperature sensor for indoor coil pipe	Replace with a good one
	No output of relay JK6 on indoor board	Damaged 2803	Replace with a good 2803
	Available output of relay JK6 on indoor board	Damaged relay JK4 on indoor board	Replace with a good JK4
		Socket CN5 is not plugged well with connection cable	Plug the connection cable well
		Faulty connection cable to transmit float feedback signal	Replace with a good one

# 11 ELECTRICAL DATA

## 11.1 Wiring diagram

HCFU-14C03 HCFU-18CC03

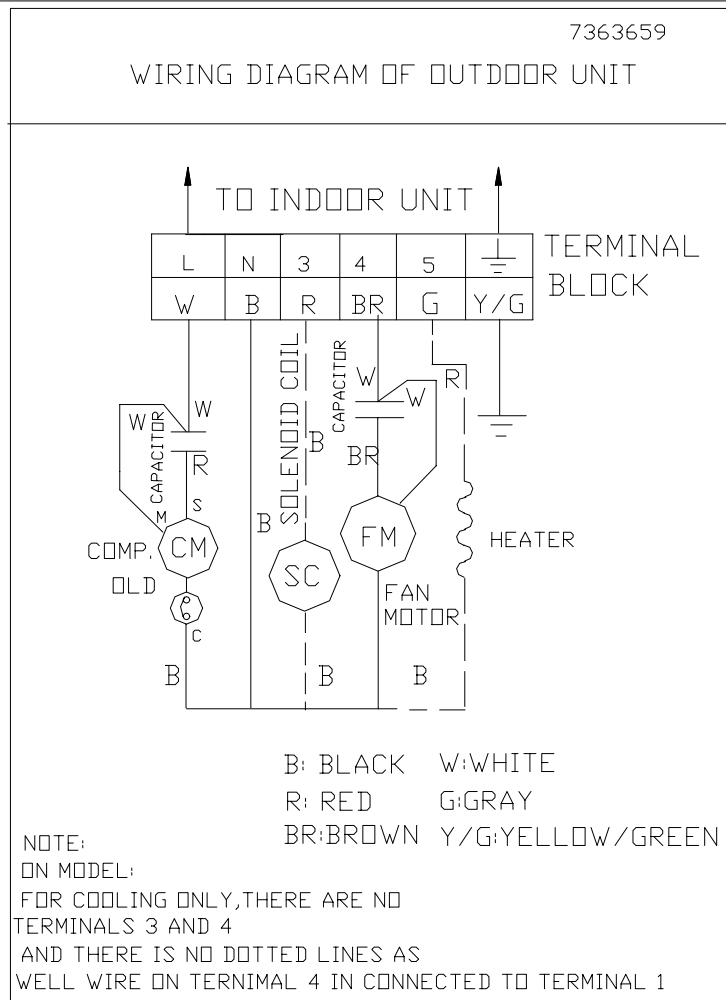
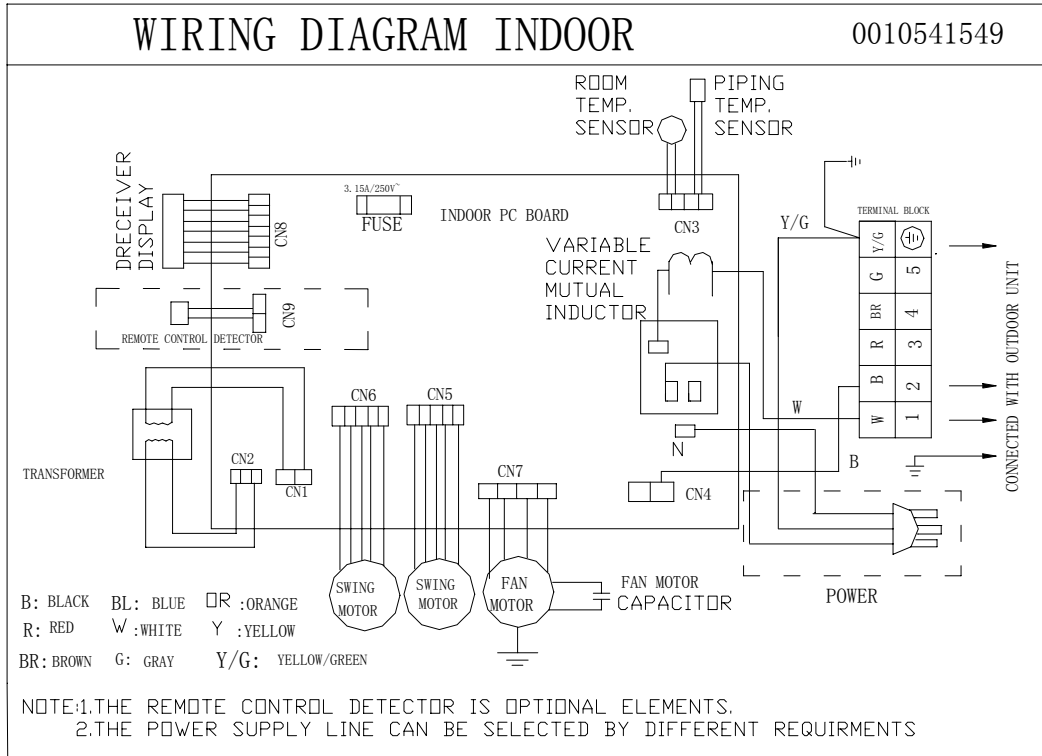

HCFU-28CC03

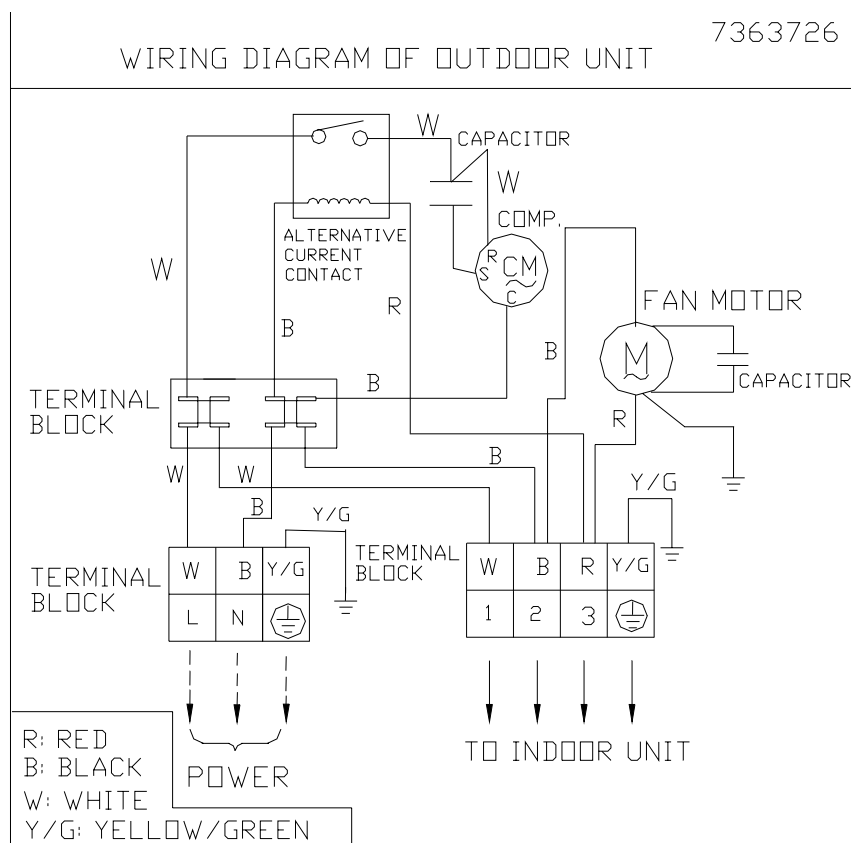
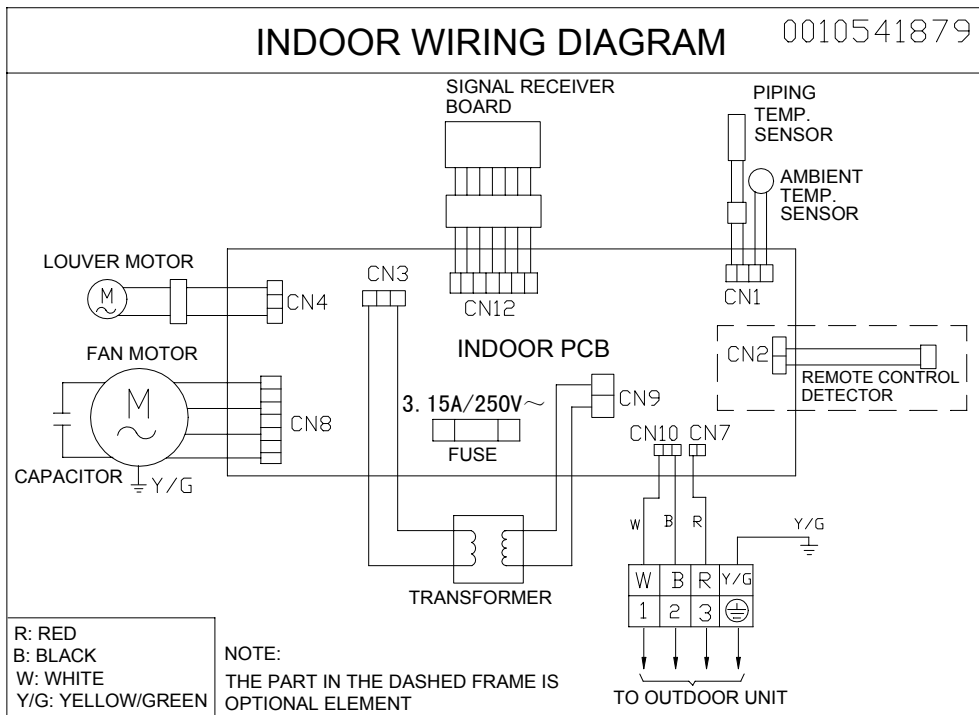

HCFU-36C03 HCFU-42CC03

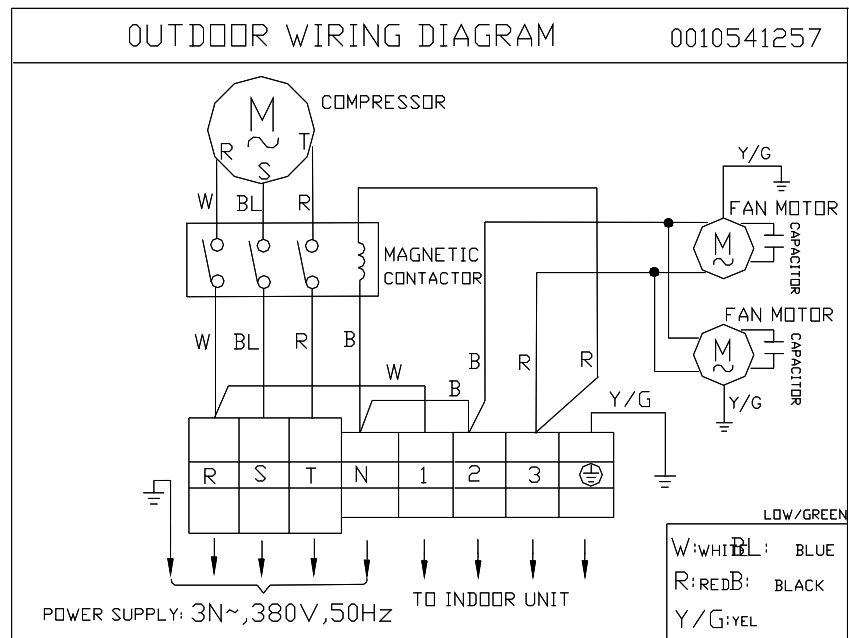
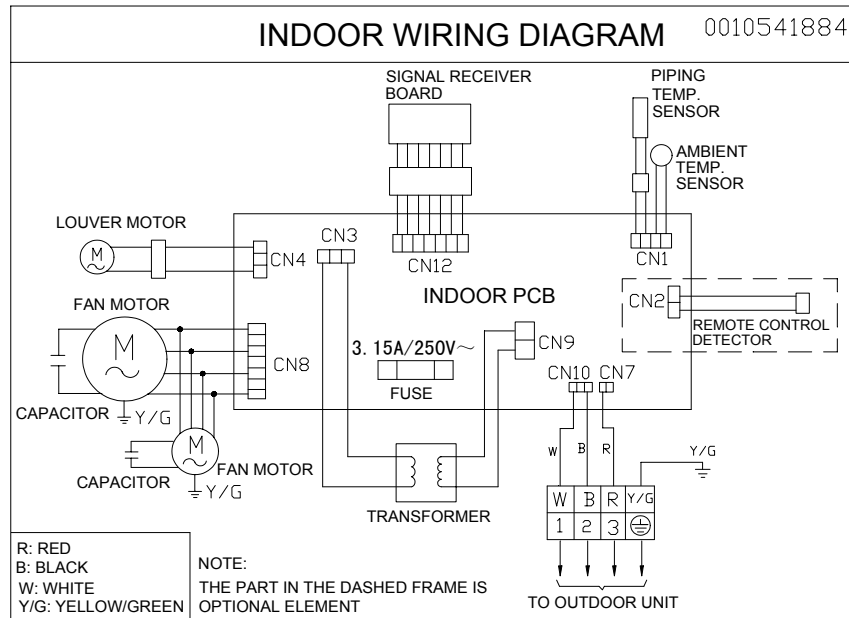

## 11.2 Circuit Diagram

### 11.2.1 Indoor unit HCFU-14CC03

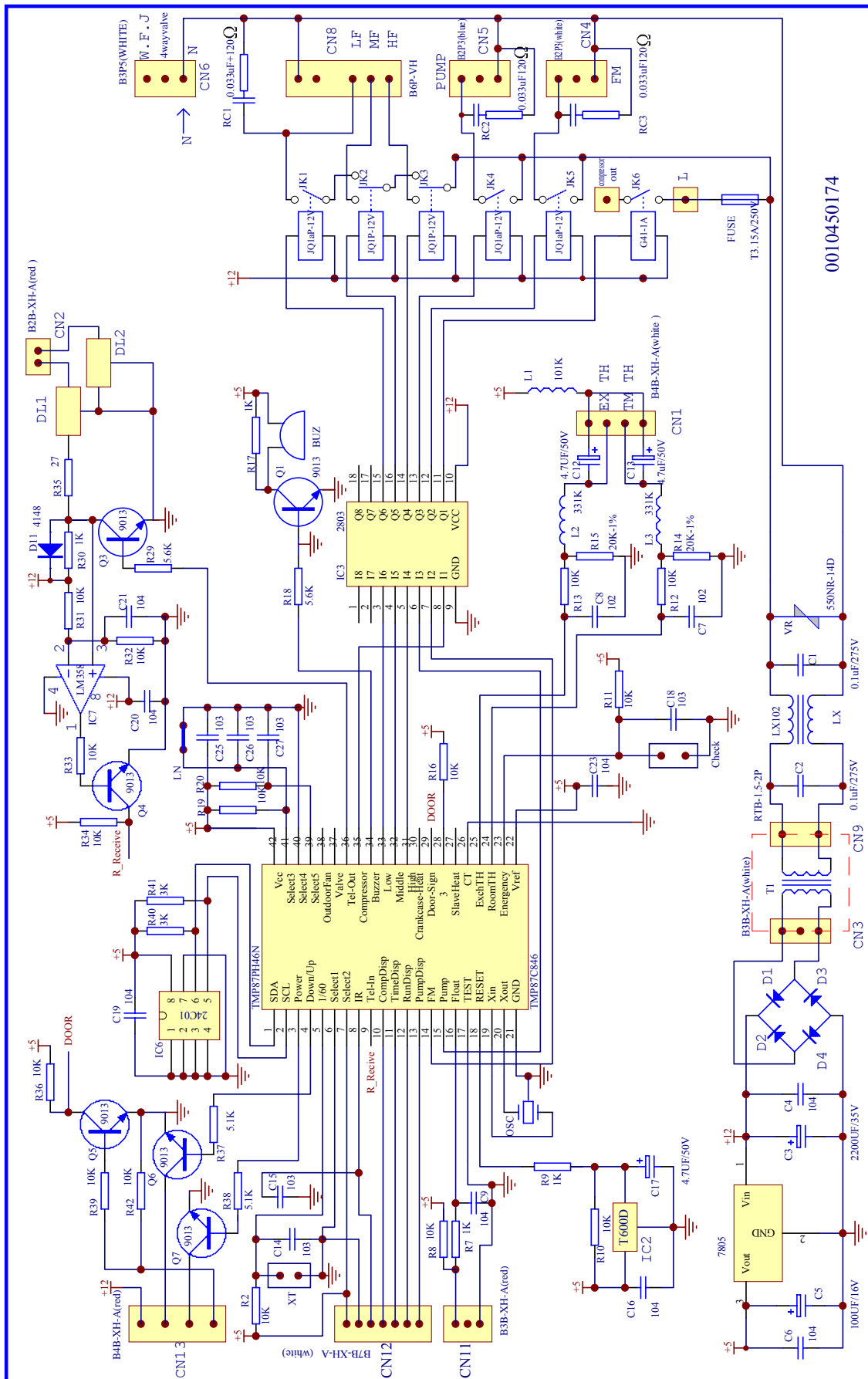

HCFU-18CC03

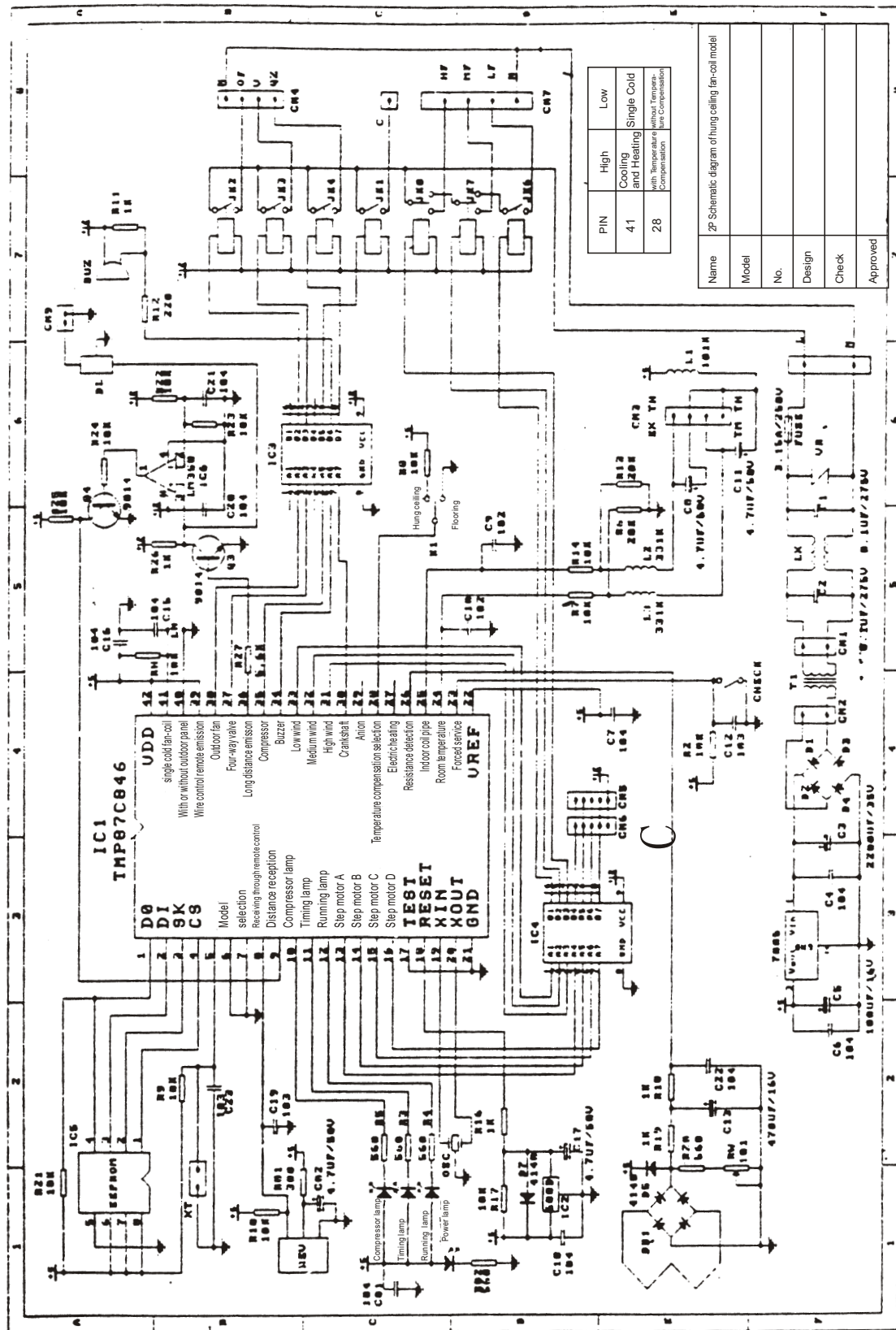





**11.3 Thermostat chart (Sensor resistance-temperature graph)**

Model: HCFU-14C03 HCFU-18CC03 HCFU-28CC03 HCFU-36C03 HCFU-42CC03

Indoor	Ambient temperature sensor	Coil temperature sensor	
	23K	10K	
Outdoor	Ambient temperature sensor	Coil temperature sensor	Fan speed controller sensor
	5K	5K	5k

R/T CHART OF SENSOR R25=23K  $\Omega$

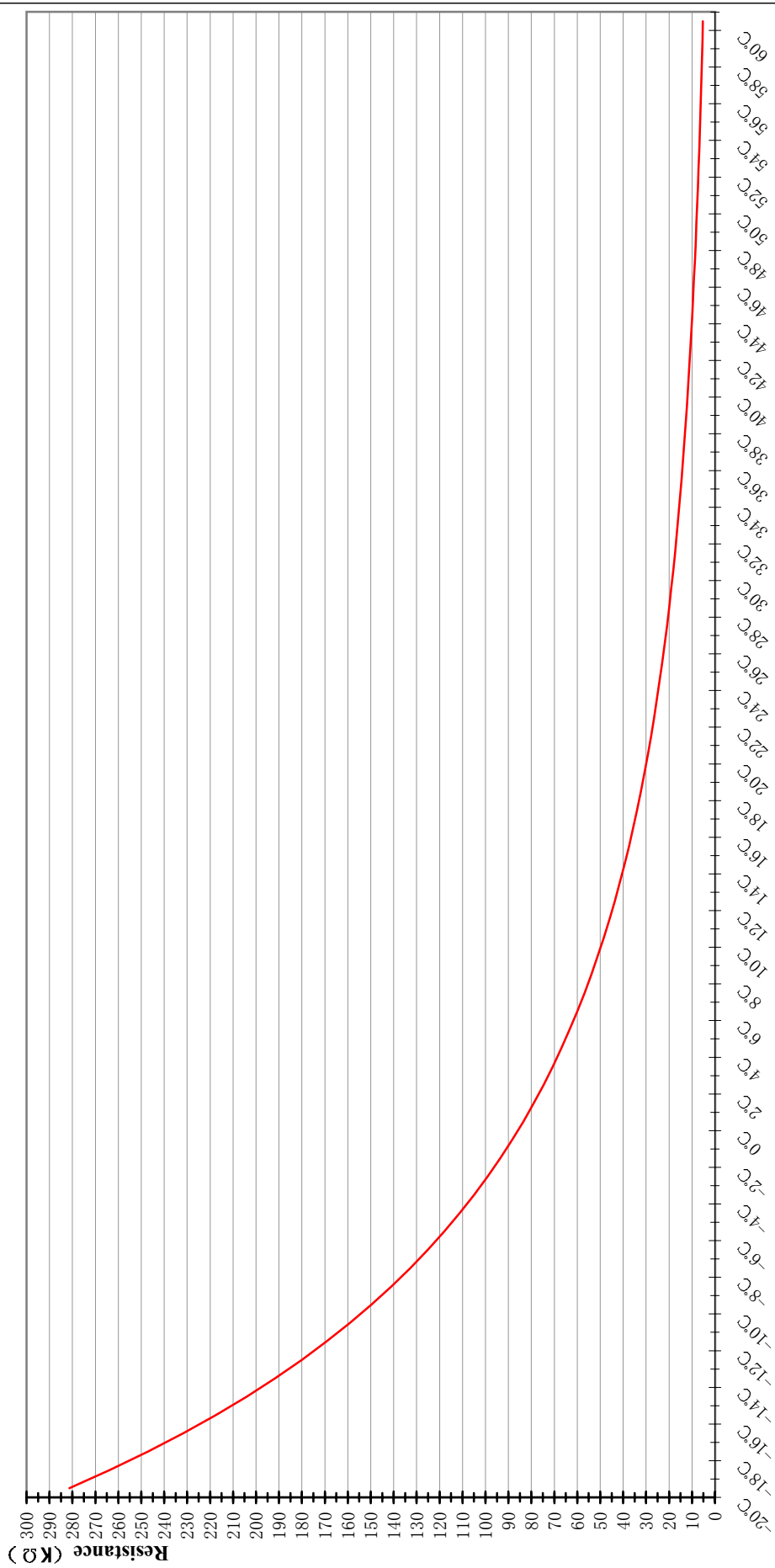

R/T CHART OF SENSOR R25 °C=5KΩ

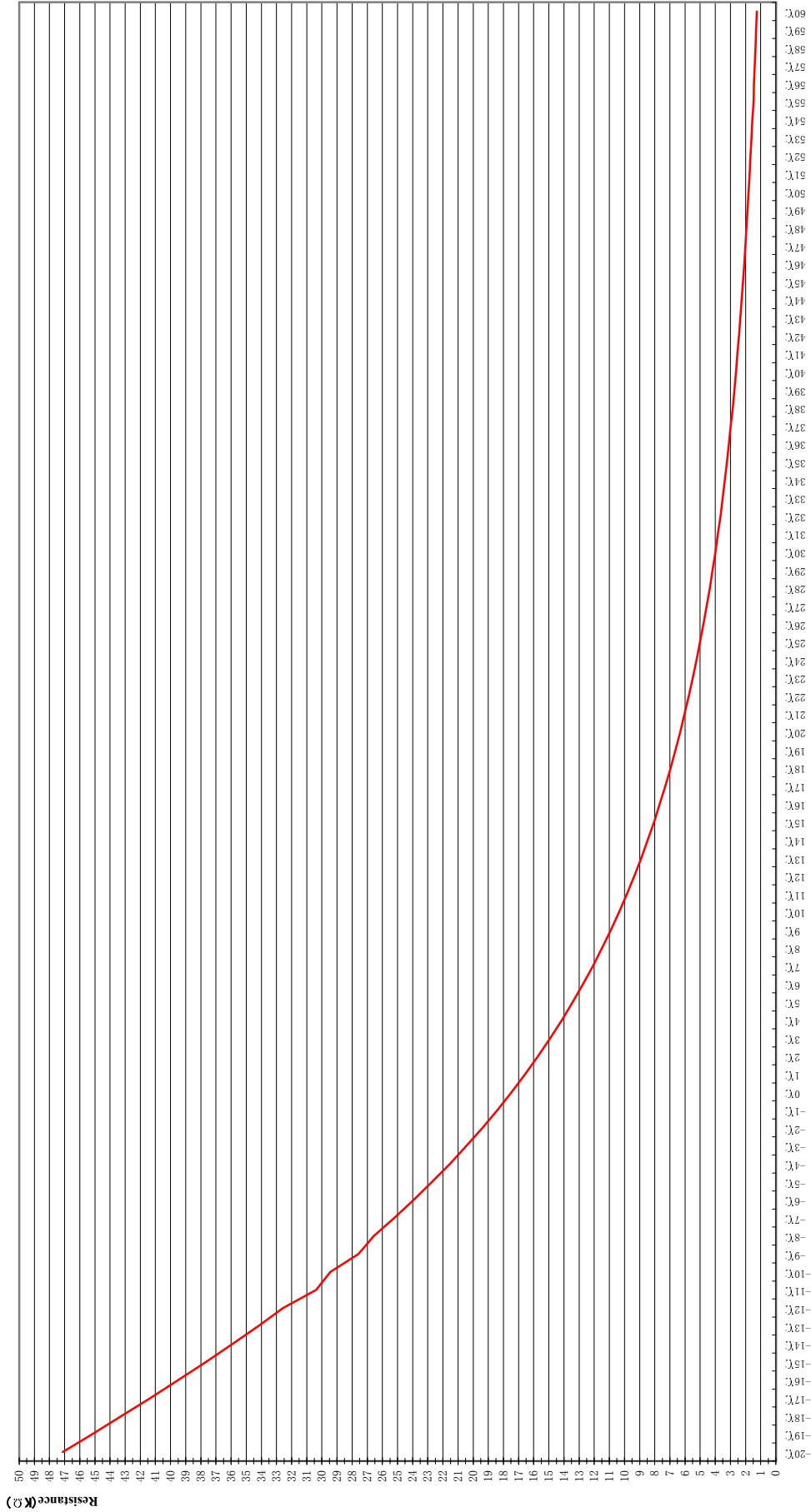

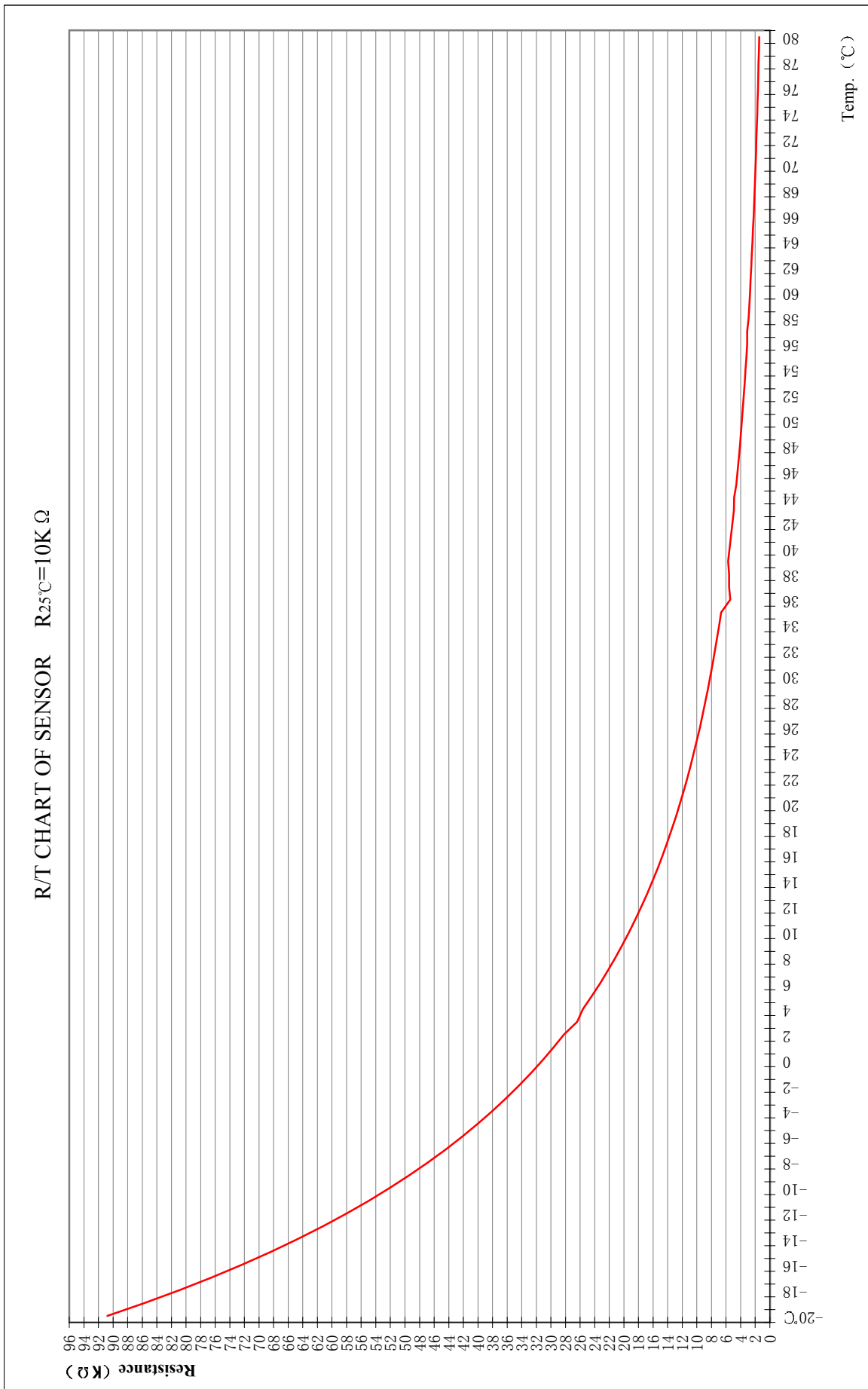

## 12 EXPLODED VIEWS & PART LISTS

### 12.1 Model HCFU-14C03 HCFU-18CC03 indoor unit

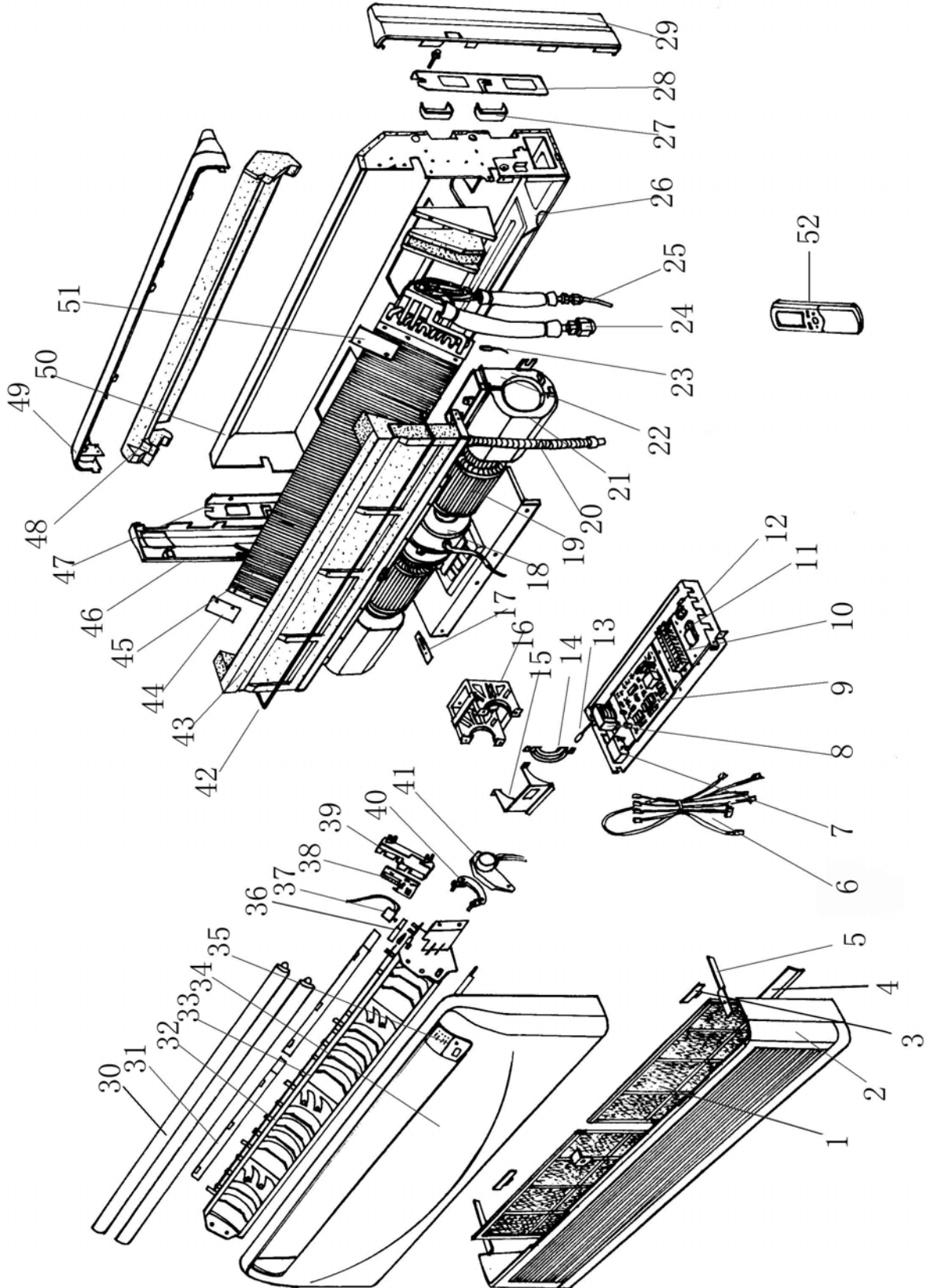

## EXPLODED VIEWS & PARTS LISTS

HCFU-14C03 HCFU-18CC03

Part list of indoor unit

No.	Name of part	specialized number	QTY.	Remark
1	air filter	001A2400087	2	
2	inlet grill assy	001A0100330	1	
3	fixing plate	001A1301398	2	
4	strengthen tendon	001A1301395	1	
5	pinch plate	001A1301399	2	
6	wiring assembly	001A4400509	1	
7	Fan motor capacitor 2uf	001A3600009B	1	
8	transformer	001A3800141	1	
9	indoor PCB	0010400020	1	
10	terminal block	001A4000084	1	
11	Power line clip	001A14311292	1	
12	wiring block	001A1431326	1	
13	environment temp. Sensor indoor	001A3900005	1	
14	clamp plate of motor	001A1301382	1	
15	connecting rod of motor	001A1301383	1	
16	Fan motor bracket	001A1301381	1	
17	small block	001A1443592	1	
18	Indoor fan motor	001A3000109	1	
19	centrifugal fan	001A2300042	2	
20	drainage elbow	001A1436664	1	
21	scroll case 1	001A1431608	2	
22	scroll case 2	001A1431609	2	
23	Pipe temp. sensor indoor	001A3900006	1	
24	Air inlet tube assy.	001A2111677	1	
25	liquid pipe	0010750130	1	
26	back framework	001A1734862	2	
27	handle	001A1436606	4	
28	right wallboard	001A1101104	1	
29	plate assy right	001A1101041	1	
30	long blade 1	001A1431593	1	
31	strengthen tendon	001A1301394	1	
32	outlet grill hold middle	001A1231180	1	
33	mini fan blade	001A1431599	1	
34	cover	001A0100329	1	
35	display panel	001A1431586	1	
36	Airflow oriented board affix	001A1431827	3	
37	curving connecting rod	001A1431598	1	
38	receive panel	001A0600249	1	
39	Indicator light base	001A1431587	1	
40	Motor bracket	001A1301133	2	
41	stepping motor	001A3000107	2	
42	fixing layering	001A1301396	1	
43	Drain pan	001A1233191	1	
44	Evaporator left holder	001A1301400	1	
45	Evaporator assembly	001A0400069	1	
46	plate assy left	001A1101099	1	
47	left wallboard	001A1101103	1	
48	assistant drain pan	001A1231192	1	
49	cover assy	001A1231182	1	
50	back framework	001A1101098	1	
51	Evaporator right holder	001A1301401	1	
52	Remote Controller	0010400256	1	

Model HCFU-14C03 HCFU-18CC03 outdoor unit

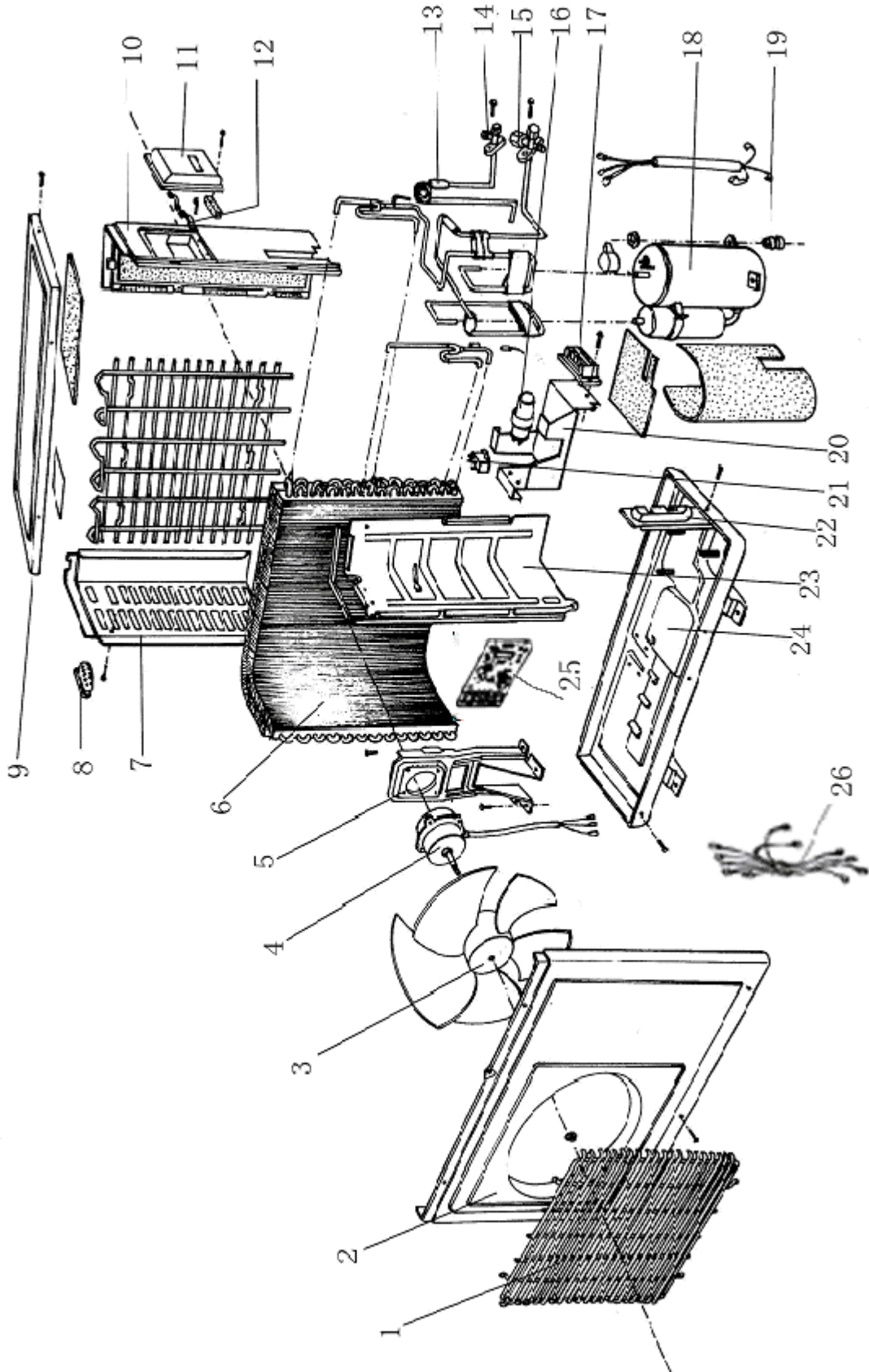



**EXPLODED VIEWS & PARTS LISTS**

HCFU-14C03 HCFU-18CCL03

Part list of outdoor unit

No.	Name of parts	Part specialized code	QTY.	Remark
1	Front guard assy.	001A0100122	1	
2	Front panel	001A1101038	1	
3	Axial fan	001A2331024	1	
4	Fan mortor	001A3000026	1	
5	Motor mounting plate	001A1301133	1	
6	Condenser assy.	001A0400130	1	
7	Slide plate(left)	001A0100356	1	
8	handle	001A1436182	2	
9	Top cover assy.	001A0100124	1	
10	Slide plate(right)	001A0100126	1	
11	Wire cover	001A0100125	1	
12	cable clamp	001A6645002	1	
13	filter	001A2411072	1	
14	2-way valve	0010700252	1	
15	3-way valve	0010700028	1	
16	Running capacitor	001A3600030	1	
17	Terminal block	001A4000107	1	
18	Compressor	0010700818	1	
19	damping mat	001A1752164	1	
20	Electrical box	001A1301129A	1	
21	fan mortor capacitor	001A3600098	1	
22	Valve pedestal	001A1301127	1	
23	Partition plate	001A0100127	1	
24	Bottom cover assy.	001A0100129	1	
25	Fan Speed Controller	0010450176	1	
26	Wiring assy.	0010450407	1	

12.2 Model HCFU-28CC03 indoor unit

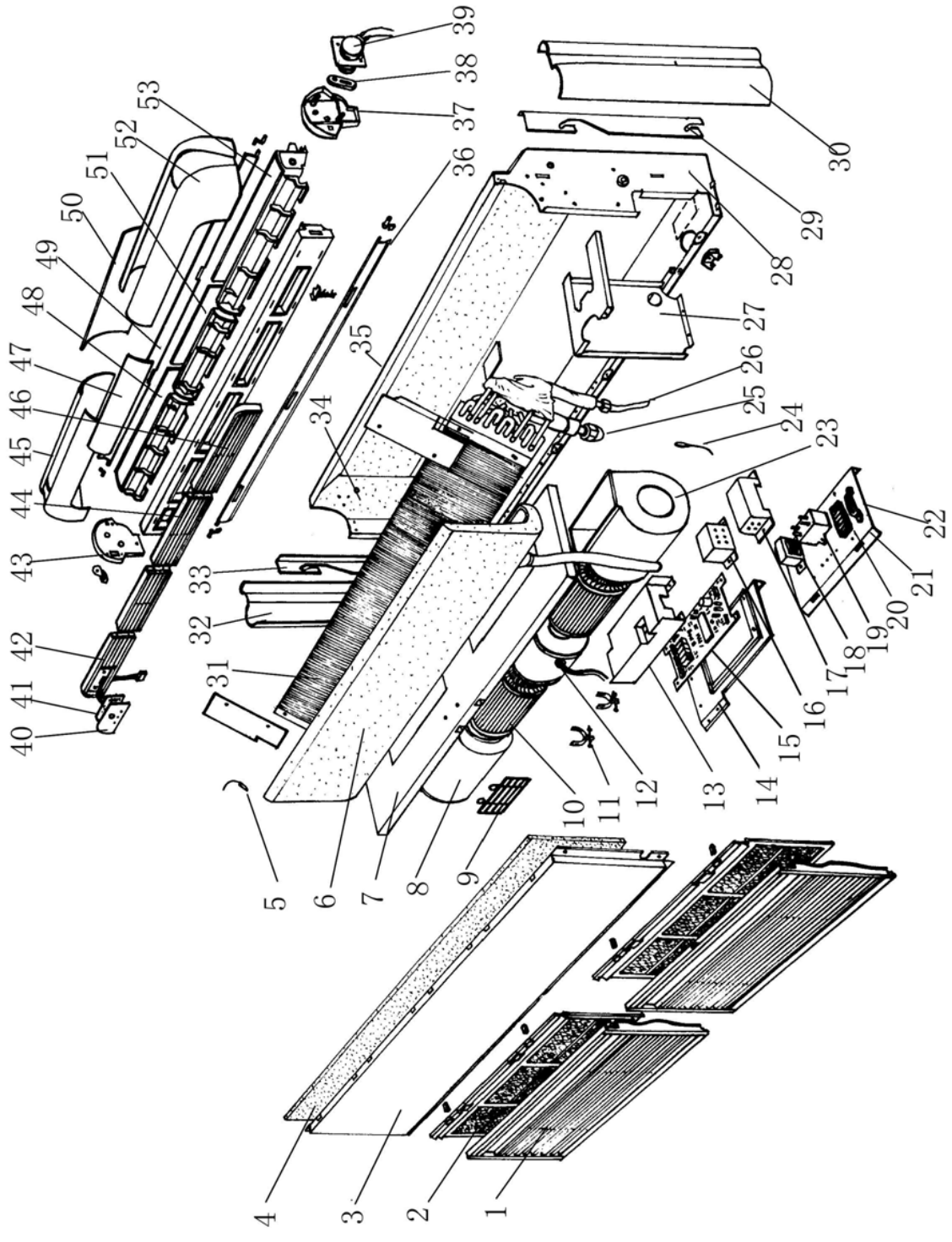

## EXPLODED VIEWS & PARTS LISTS

### HCFU-28CC03

No.	Name of parts	Part specialized code	QTY.	Remark
1	inlet grill assy	001A1231278	2	
2	air filter	001A2400108	2	
3	front panel assy	001A1101174	1	
4	pad	001A17341062	1	
5	Pipe temperature sensor	001A3900006	1	
6	drain pan assy	001A1200185	1	
7	mounting plate	001A1101179	1	
8	left scroll case	001A1301574	1	
9	motor holder	001A1301581	1	
10	centrifugal fan	001A2331071	2	
11	motor bracket	001A1301580	2	
12	motor	001A3000172	1	
13	electric box assy	001A1301379	1	
14	Eletrical box	001A13011280	1	
15	indoor PCB	0010400407	1	
18	transformer	001A3800066	1	
19	capacitor	001A3600018	1	
20	termonal block	001A4000151	1	
22	Power line clip	001A5701009	1	
23	scroll case right	001A1301582	1	
24	environment temperature sensor	001A3900159	1	
25	air pipe	001A2111028	1	
26	liquid pipe	001A2111033	1	
27	partition plate	001A1301588	1	
28	plate assy right	001A1301577	1	
29	right wallboard	001A1301579	1	
30	ornamental plate right	001A1231277	1	
31	evaportor	001A0400126	1	
32	ornamental plate left	001A1231276	1	
33	left wallboard	001A1301578	1	
34	plate assy left	001A1301575	1	
35	rear guard plate	001A1101178	1	
36	blade assy	001A1101176	1	
37	fixing bracket right	001A1431746	1	
38	prompting pole	001A1443745	1	
39	Synchromotor	001A3000198	1	
40	Indicator light cover	001A1431878	1	
41	receive panel	0010400410	1	
42	ornamental plate of panel(left)	001A1231279	1	
43	fixing bracket left	001A1431800	1	
44	middle ornamental plate	001A1231280	2	
45	left top cover assy	001A1231272	1	
46	Ornamental plate of panel right	001A1231281	1	
47	front top cover assy	001A1231274	1	
48	left fixing bracket	001A0100431	1	
49	blade assy2	001A1101177	1	
50	top cover assy	001A1231275	1	
51	middle outlet grill hold	001A1231284	1	
52	right top cover assy	001A1231273	1	
53	outlet grill hold right	001A0100432	1	
54	Remote Controller	0010400256	1	

Model HCFU-28CC03 outdoor unit

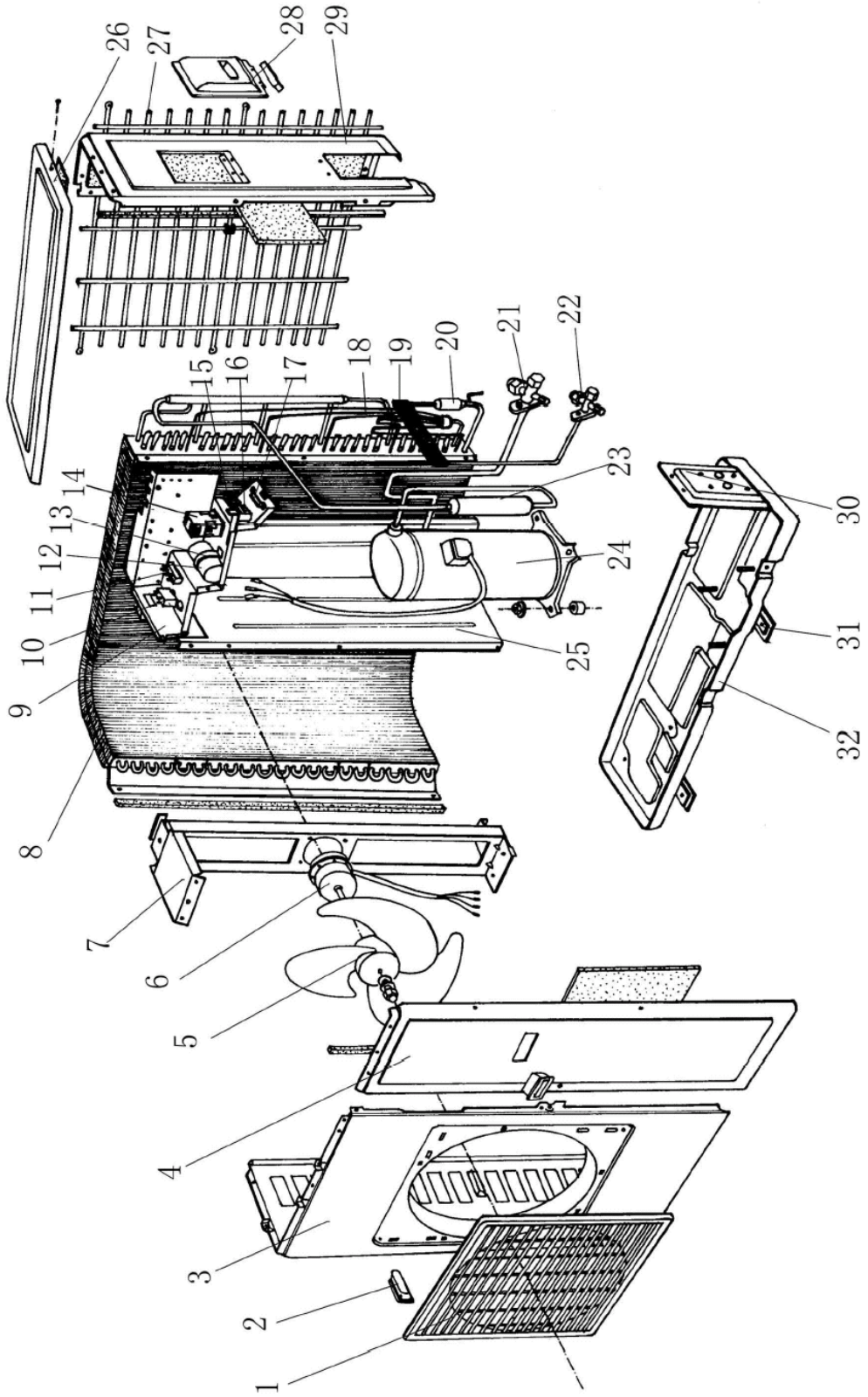

## EXPLODED VIEWS & PARTS LISTS

HCFU-28CC03

Part list of outdoor unit

No	Name of parts	Part specialized code	QTY.	Remark
1	Front grille	001A1236028	1	
2	handle	001A1436160	2	
3	Front panel	001A1101078	1	
4	service panel assy	001A0100524	1	
5	Axial fan	001A5402022	1	
6	Fan motor	001A3000082	1	
7	Bracket for fan motor	001A0100266	1	
8	Condenser assy.	001A0400119	1	
9	Electric box	001A1301453	1	
10	Capacitor for fan motor	001A3600018	1	
11	connection block	001A4000011	1	
12	Capacitor for compressor	001A3600030	1	
13	Capacitor clamp	0010100001	1	
14	AC contactor	001A3900161	1	
15	Terminal block	001A4000151	1	
16	electrical source connection block	001A4000110	1	
17	cable clamp	001A5731054	1	
18	outlet Air pipe assy.	001A0500368	1	
19	inlet Air pipe assy.	001A0500364	1	
20	filter	001A2411023	1	
21	3-way stop valve	001A2500154	1	
22	2-way stop valve	001A2500153	1	
23	muffle	001A2111911	1	
24	Compressor(ZR34K3E-PFJ-522)	001A2000201	1	
25	Partition plate	001A0100350	1	
26	Top cover assy.	001A0100264	1	
27	Back grille	001A0100109	1	
28	Junction box	001A0100394	1	
29	Slide plate(right)	001A0100390	1	
30	Valve pedestal	001A1301506	1	
31	branch triby	001A1301117	2	
32	Bottom cover assy.	001A0100351	1	
33	Wiring assy.	0010450408	1	
34	Fan Speed Controller	0010450176	1	

12.3 Model HCFU-36C03 HCFU-42CC03 indoor unit

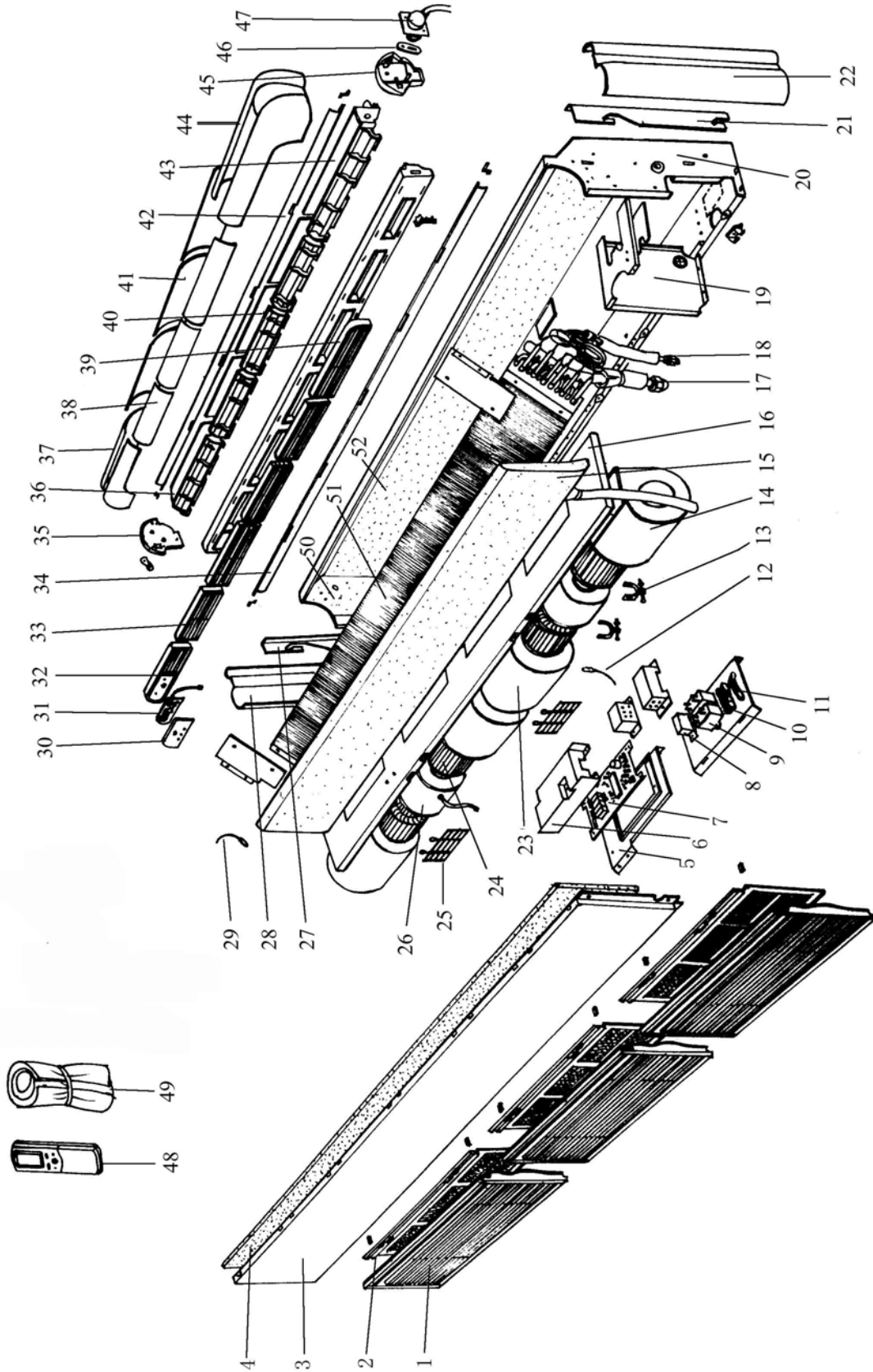

## EXPLODED VIEWS & PARTS LISTS

HCFU-36C031 HCFU-42CC03

Part list of indoor unit

No.	Name of parts	Part specialized code	QTY.	Remark
1	inlet grill assy	001A1231278	3	
2	air filter	001A2400108	3	
3	front panel assy	001A1101167	1	
4	pad	001A17341009	1	
5	Eletrical box	001A13011280	1	
6	Eletrical box cover	001A1301379	1	
7	PCB	0010400407	1	
8	transformer	001A3800066	1	
9	capacitor	01A3600018	2	
10	terminal block	001A4000151	1	
11	Power line clip	001A5701062	1	
12	environment temp. sensor indoor	001A3900159	1	
13	motor bracket	001A1301580	4	
14	scroll case right	001A1301582	2	
15	drain pan assy	001A1200325	1	
16	mounting plate	001A1101172	1	
17	air pipe	001A0500403	1	
18	liquid pipe	001A0500404	1	
19	partition plate	001A1301588	1	
20	plate assy right	001A1301577	1	
21	right wallboard	001A1301579	1	
22	Ornamental plate right	001A1231277	1	
23	left scroll case	001A1301574	2	
24	centrifugal fan	01A2331071	4	
25	motor bracket	001A1301581	2	
26	Indoor fan motor	001A3000172	2	
27	left wallboard	001A1301578	1	
28	ornamental plate (left)	001A1231276	1	
29	Pipe temp. sensor indoor	001A3900006	1	
30	Indicator light cover	001A1431878	1	
31	receive panel	0010400410	1	
32	ornamental plate of panel(left)	001A1231279	1	
33	middle ornamental plate	001A1231280	4	
34	Long blade assy	001A1101169	1	
35	fixing bracket left	001A1431800	1	
36	left fixing bracket	001A0100431	1	
37	left top cover assy	001A1231272	1	
38	front top cover assy	001A1231274	3	
39	Ornamental plate of panel right	001A1231281	1	
40	outlet grill hold middle	001A0100435	3	
41	top cover assy	001A1231275	3	
42	long blade 2	001A1101170	1	
43	outlet grill hold right	001A0100432	1	
44	right top cover assy	001A1231273	1	
45	fixing bracket right	001A1431746	1	
46	prompting pole	001A1443745	1	
47	Synchromotor	001A3000198	1	
48	Remote Controller	0010400256	1	
49	Heat insulation pipe1	001A1734260	1	
50	plate assy left	001A1301575	1	
51	evaporator	0010700388	1	
52	Rear guard plate	001A1101171	1	

HBU-36C03 HBU-42CC03 Outdoor Units

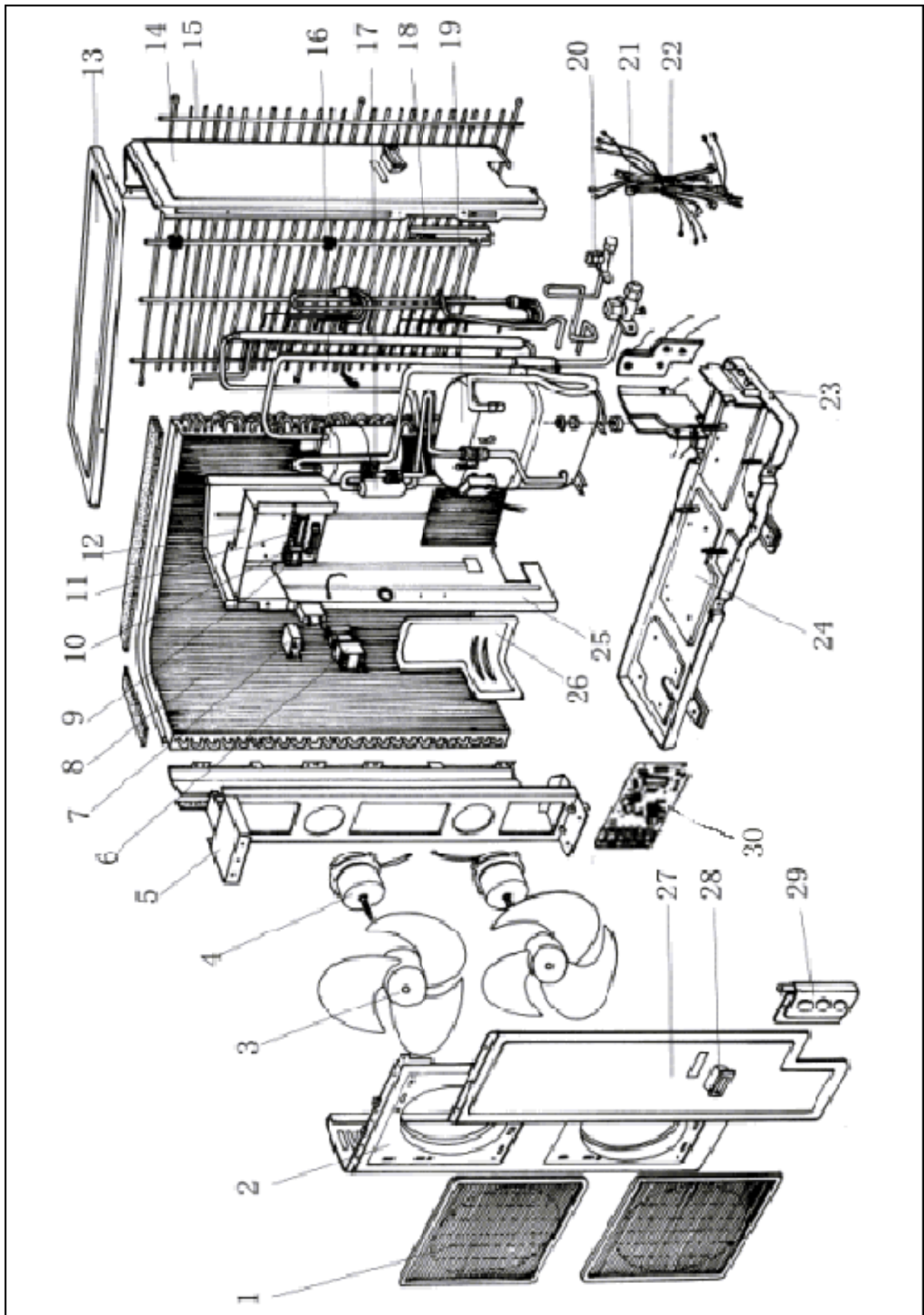



## EXPLODED VIEWS & PARTS LISTS

HCFU-36C03    HCFU-42CC03

Part list of indoor unit

No.	Name of parts	Part specialized code	QTY.	Remark
1	Front grille	001A1236028	2	
2	Front panel	001A0100492	1	
3	Axial fan	001A5402022	2	
4	Fan motor	001A3000244	2	
5	Bracket for fan motor	001A0100740	1	
6	AC contactor	001A3900161	1	
7	Capacitor for fan motor	001A3600018	2	
8	Condenser assy.	001A0400165	1	
9	connection block	001A4000011	1	
10	cable clip	001A5701062	1	
11	Terminal block	001A4000158	1	
12	Electric box	001A1301708	1	
13	Top cover assy.	001A0100827	1	
14	Slide plate(right)	001A0100733	1	
15	Back grille	001A0100495	1	
16	segregator	001A2000175	1	
17	muffle	001A2400128	1	
18	fix panel	001A1301465	1	
19	Compressor	001A2000200	1	
20	2-way stop valve	001A2500149	1	
21	3-way stop valve	001A2500150	1	
22	wiring harness	0010450409	1	
23	Valve pedestal	001A1301762	1	
24	Bottom cover assy.	001A0100735	1	
25	Partition plate	001A0100734	1	
26	Partition plate tray	001A17561212	1	
27	service panel assy	001A1301707	1	
28	handle	001A1436160	1	
29	cover	001A1301763	1	
30	Fan Speed Controller	0010450176	1	

### 13 PERFORMANCE CURVES

HCFU-14C03

Cool capacity graph

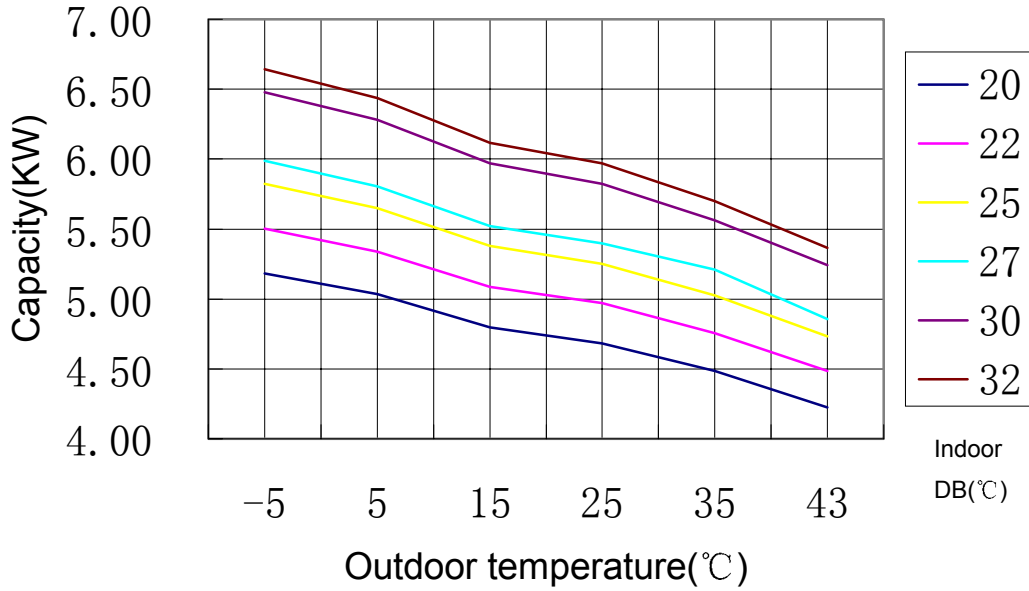

EER graph

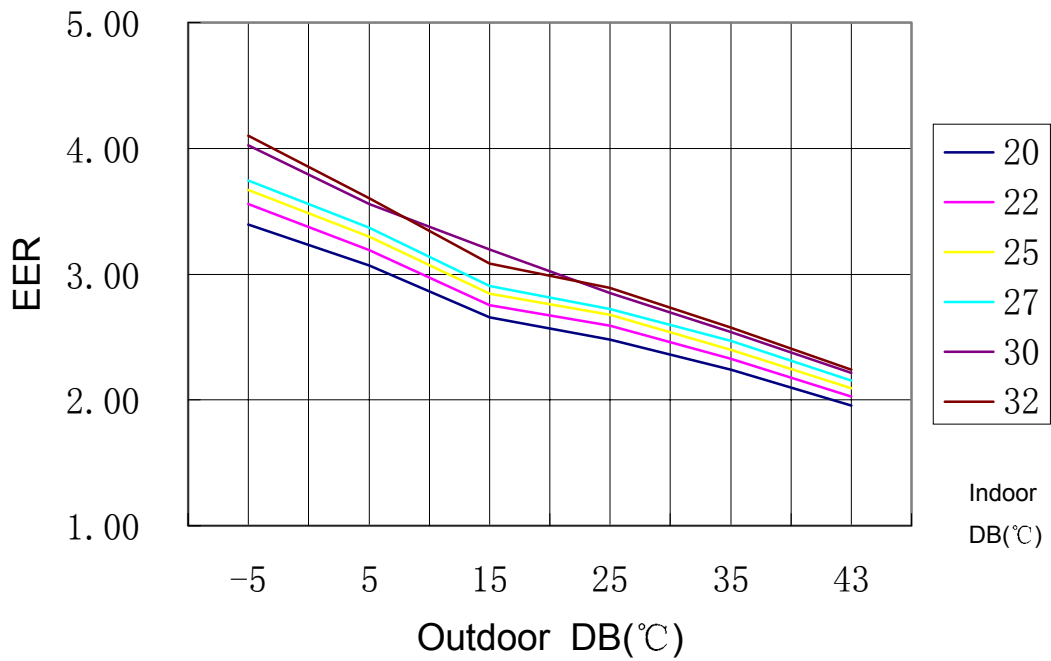

HCFU-18CC03

Cool capacity graph

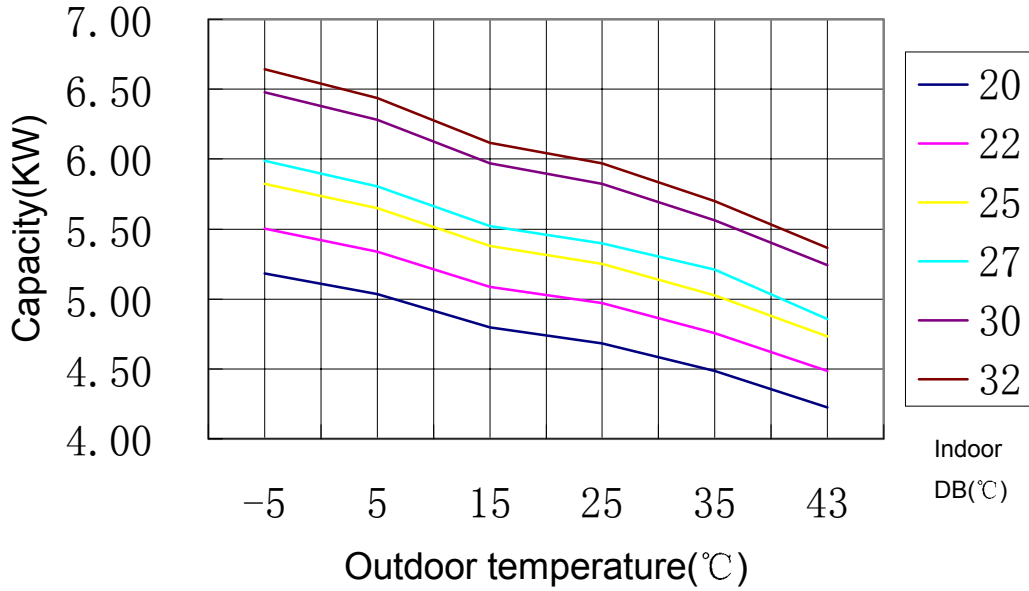

EER graph

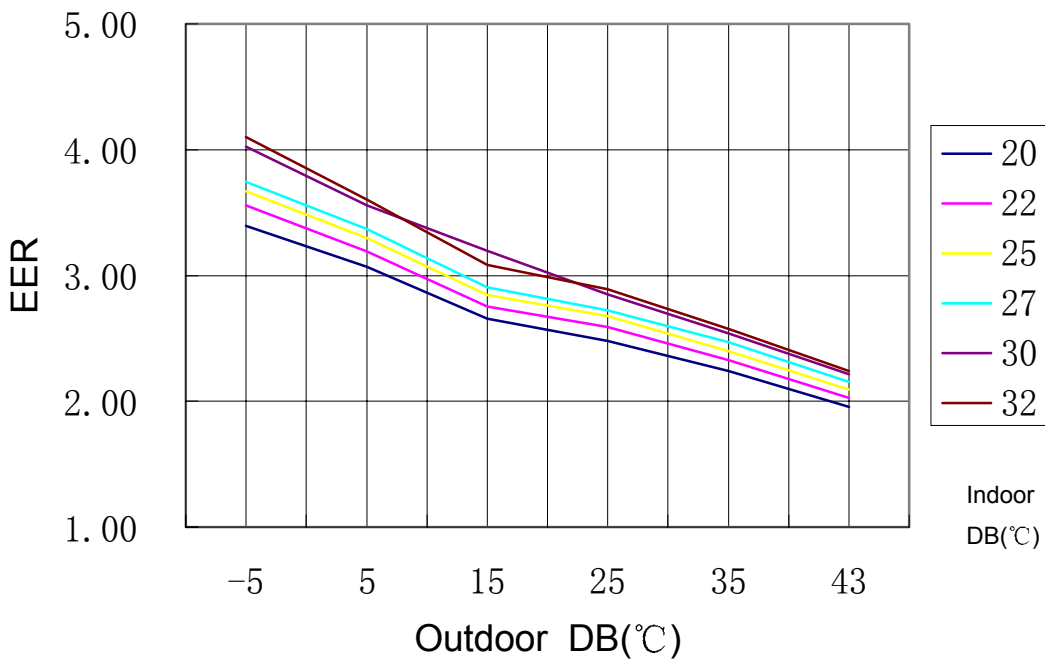

HCFU-28CC03

Cool capacity graph

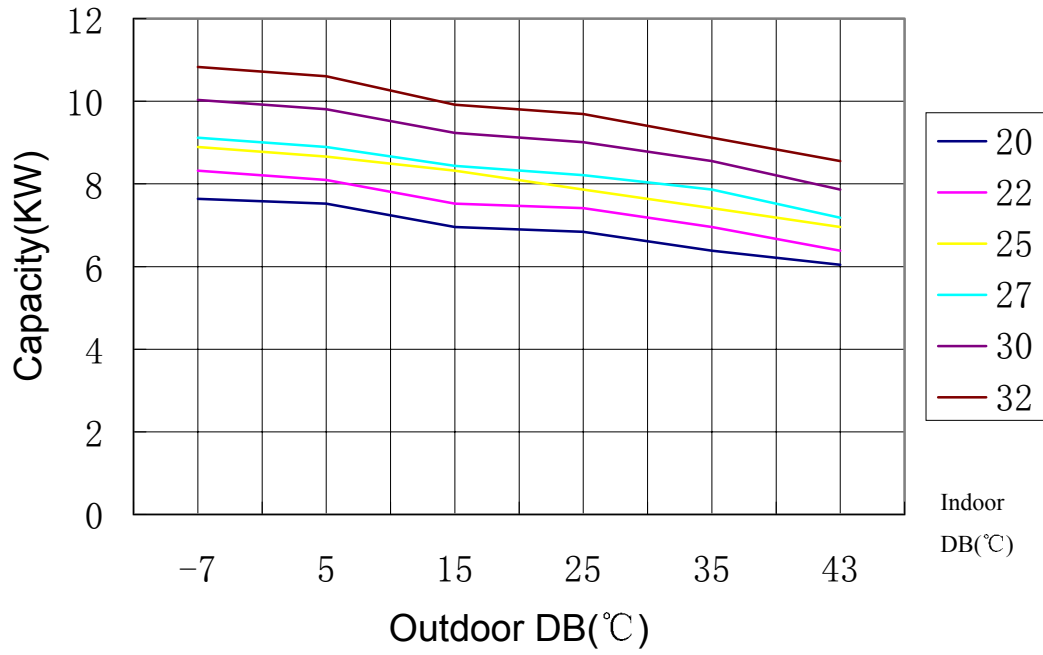

EER graph

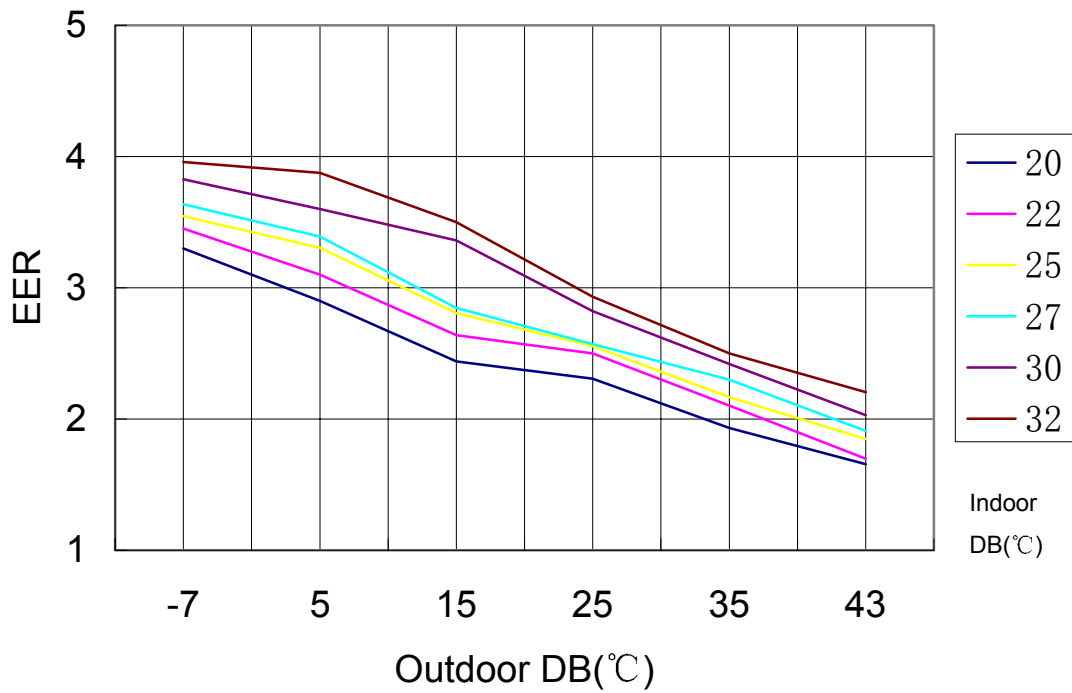

HCFU-36C03

Cool capacity graph

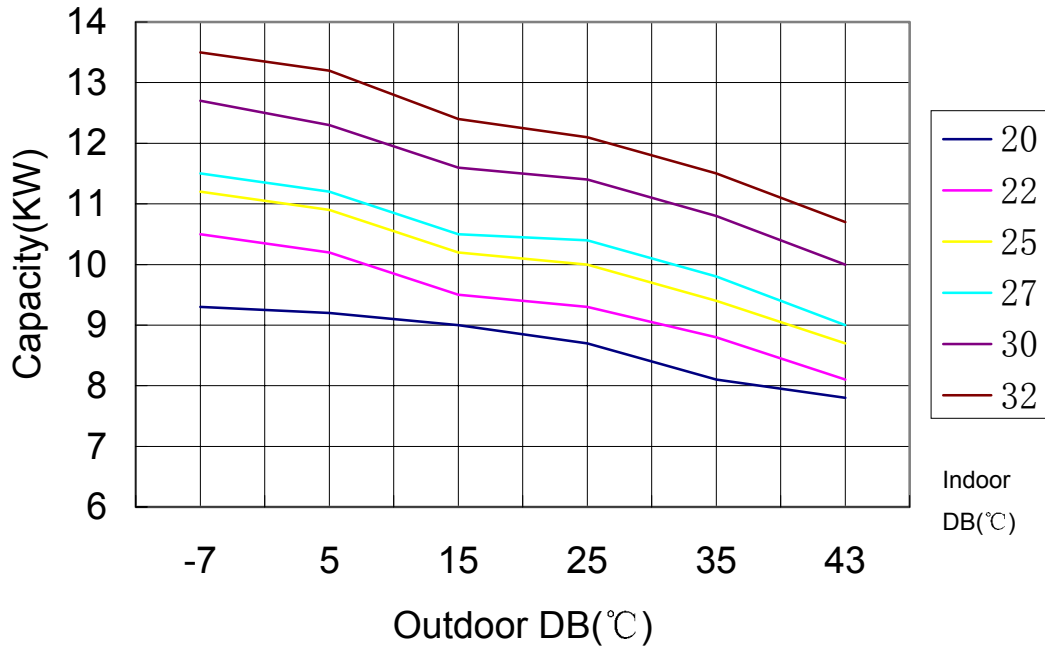

EER graph

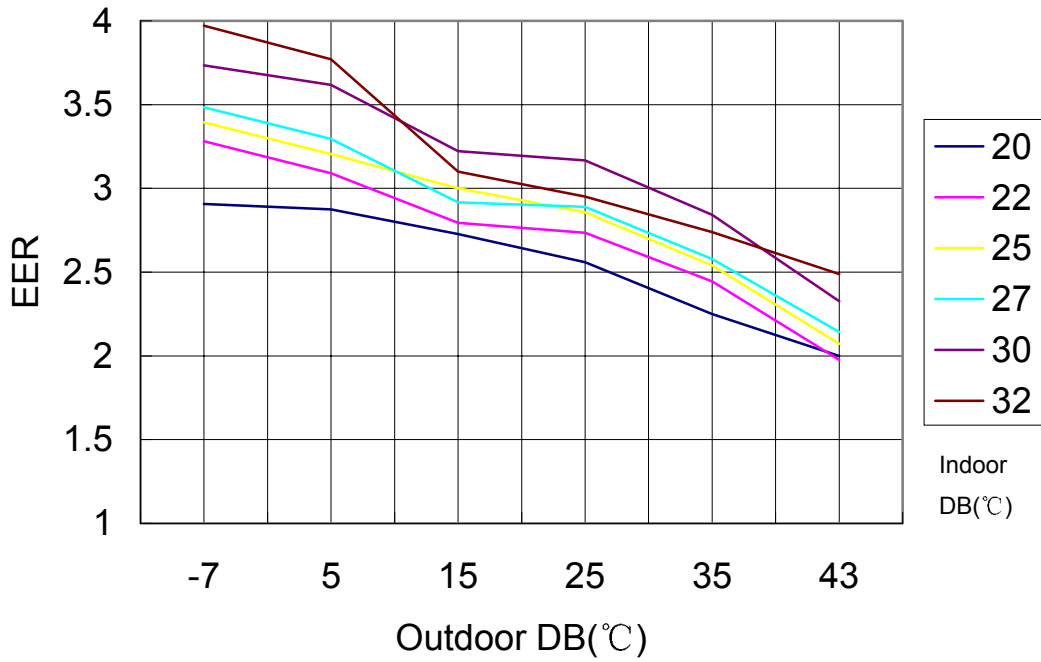

HCFU-42CC03

Cool capacity graph

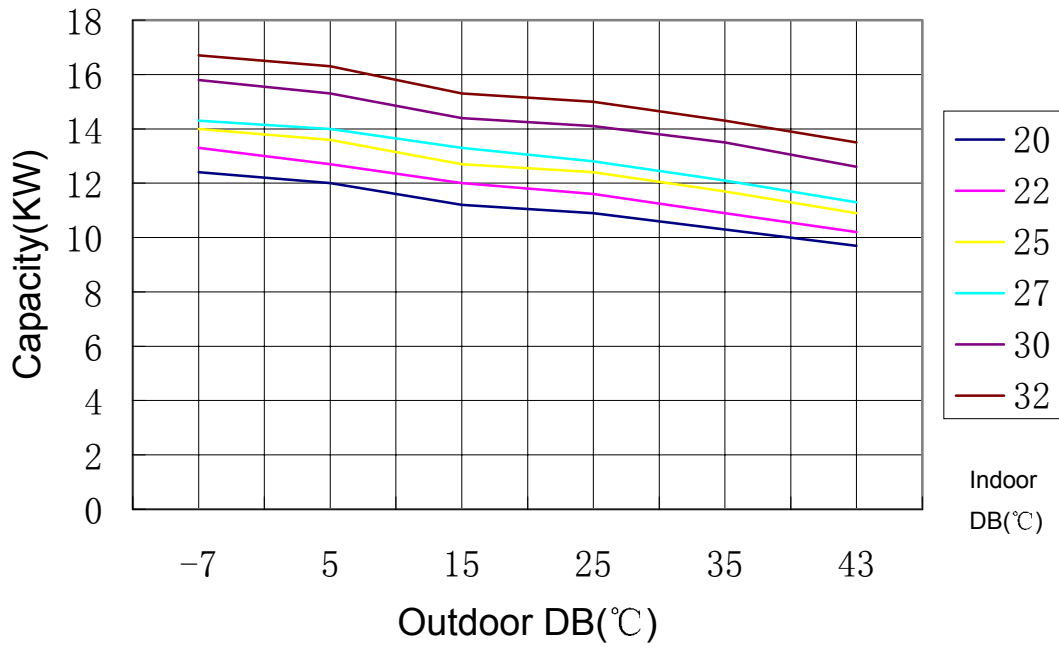

EER graph

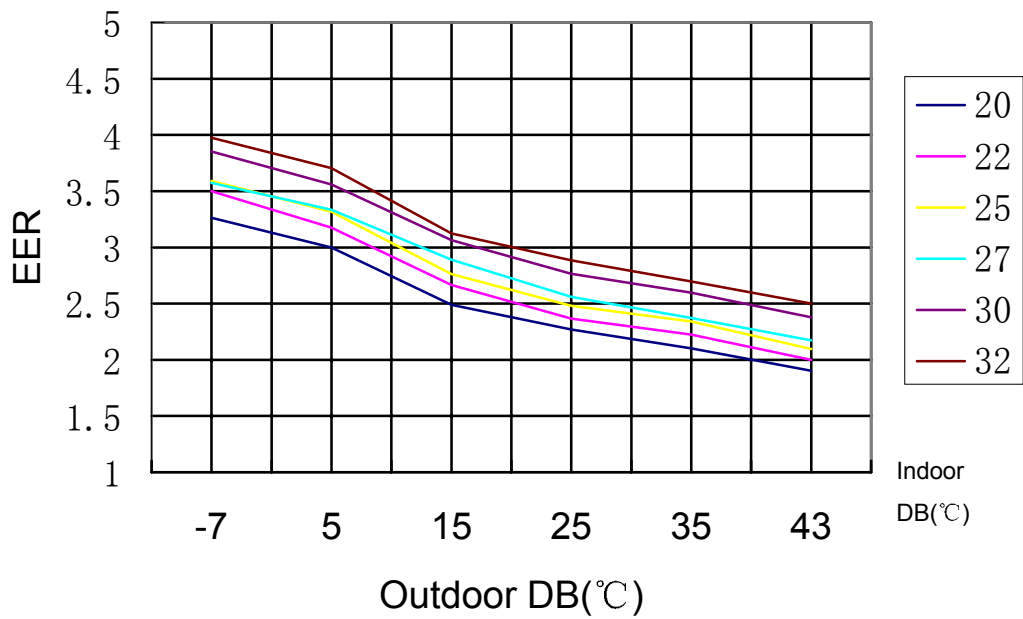

**14 NOISE LEVEL TEST CHART**

# 15 AIR VELOCITY DISTRIBUTION

Model: HCFU-14C03 HCFU-18CC03

a. Cooling / Air Velocity Distribution

Cooling  
Blow angle: 25  
Air Velocity Distribution

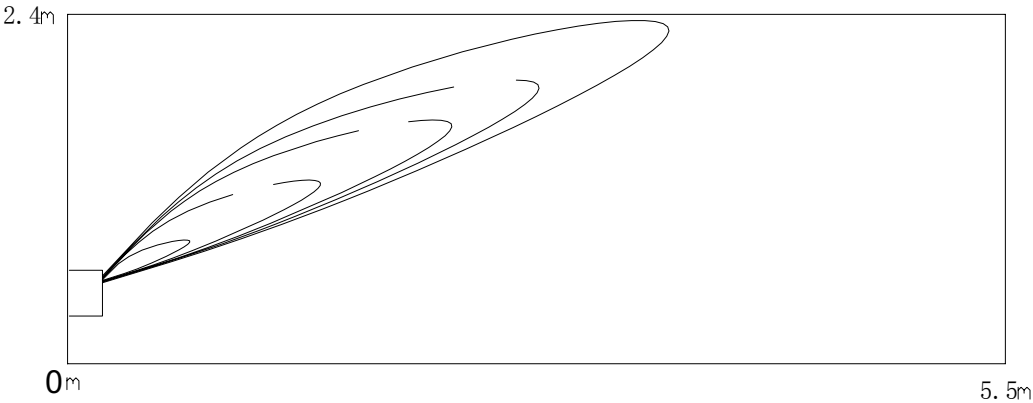

b. Cooling / Temperature Distribution

Cooling  
Blow angle:25  
Temperature Distribution

2

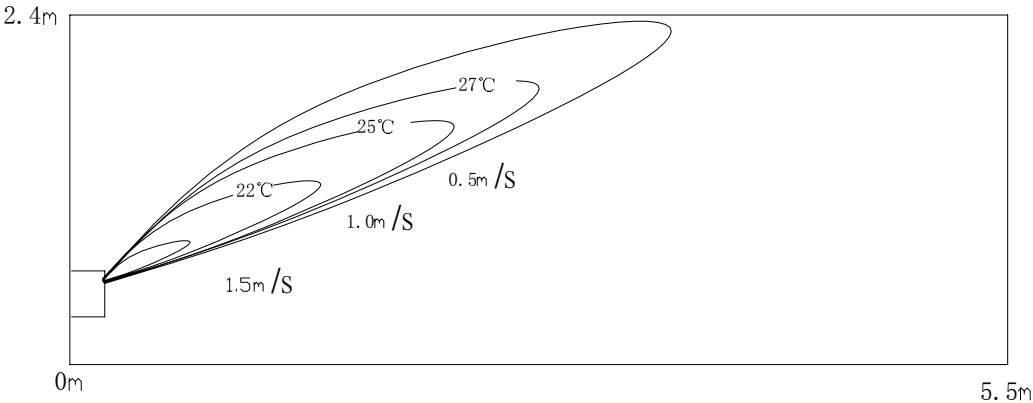



Model: HCFU-28CC03

a. Cooling / Air Velocity Distribution

Cooling  
Blow angle:25  
Air Velocity Distribution

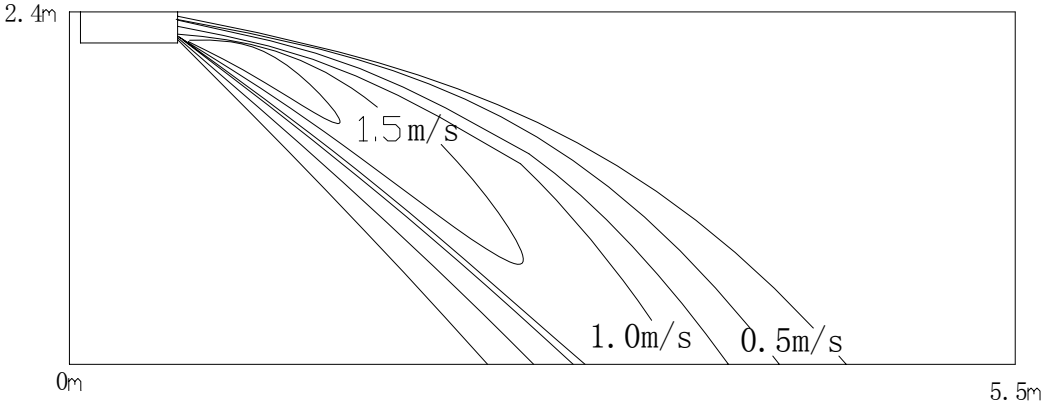

b. Cooling / Temperature Distribution

Cooling  
Blow angle:25  
Temperature Distribution

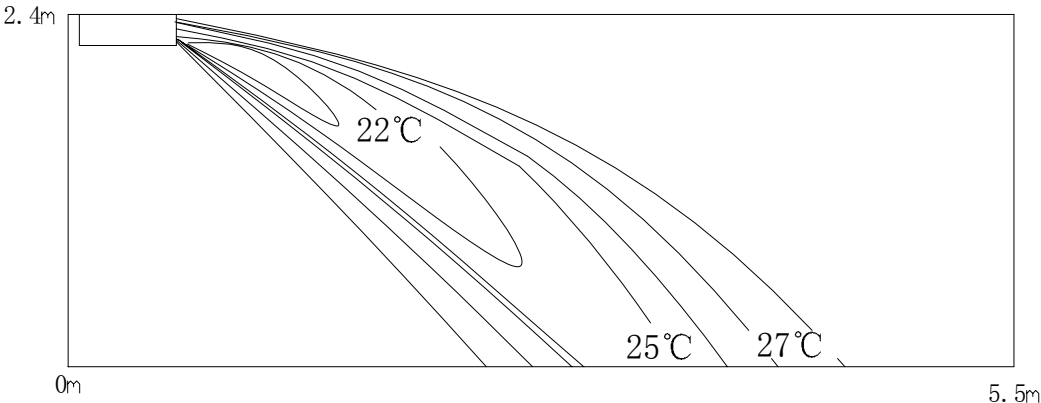

15.2 Ceiling type

Model: HCFU-36C03 HCFU-42CC03

a. Cooling / Air Velocity Distribution

Cooling

Blow angle: 25

Air Velocity Distribution

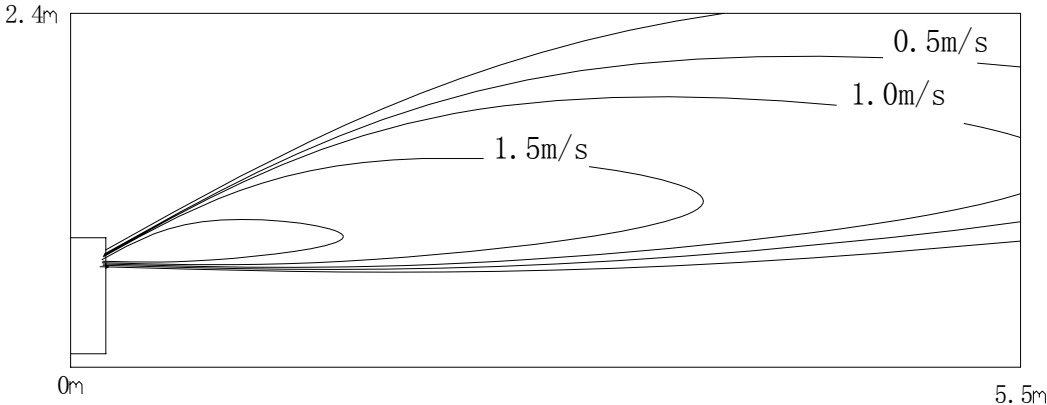

b. Cooling / Temperature Distribution

Cooling

Blow angle:25

Temperature Distribution

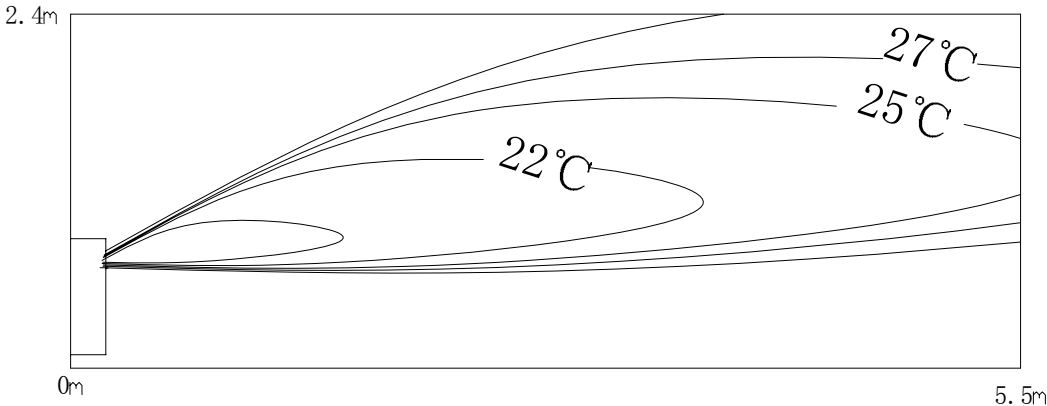

# Sincere Forever



Tel: 86-532-8938356

---

Web site: <http://www.haier.com>