

HBU-14H03(AB142ACAAA+AU142AFABA)  
HBU-18HC03(AB182ACACA+AU182AFACA)  
HBU-24H03(AB242ACAAA+AU242AHABA)  
HBU-28HD03(AB282ACACA+AU282AHADA)  
HBU-36H03(AB36NACAAA+AU36NAIAAA)  
HBU-42HD03(AB42NACACA+AU42NAIACA)

## ● Features

- Auto-restart function
- Group control(if connect with a group controller)
- Auto-changeover
- Compact design of indoor unit
- Weekly timing(if connect with a weekly timer)

## CONTENTS

Contents.....	1
1. Description of Products & Features.....	1
2. Specifications.....	3
3. Safety precaution.....	9
4. Net dimensions of indoor and outdoor unit.....	11
5. Installation instructions .....	17
6. Parts and functions .....	28
7. Remote controller functions.....	31
8. Refrigerant diagram.....	43
9. Electrical control functions.....	44
10. Diagnostic information(trouble shooting).....	51
11. Electrical data.....	56
12. Exploded views and parts lists.....	67
13. Performance curves.....	87
14. Noise level charts.....	93
15. Air velocity distribution .....	94

# 1 DESCRIPTION OF PRODUCTS & FEATURES

## 1.1 Products coding direction

Old code

H BU - 42 H D 03

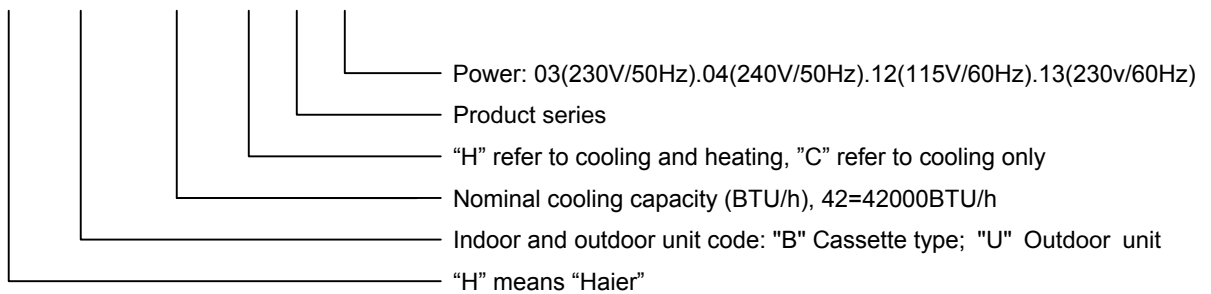

New code

A B 42 N A C A C A

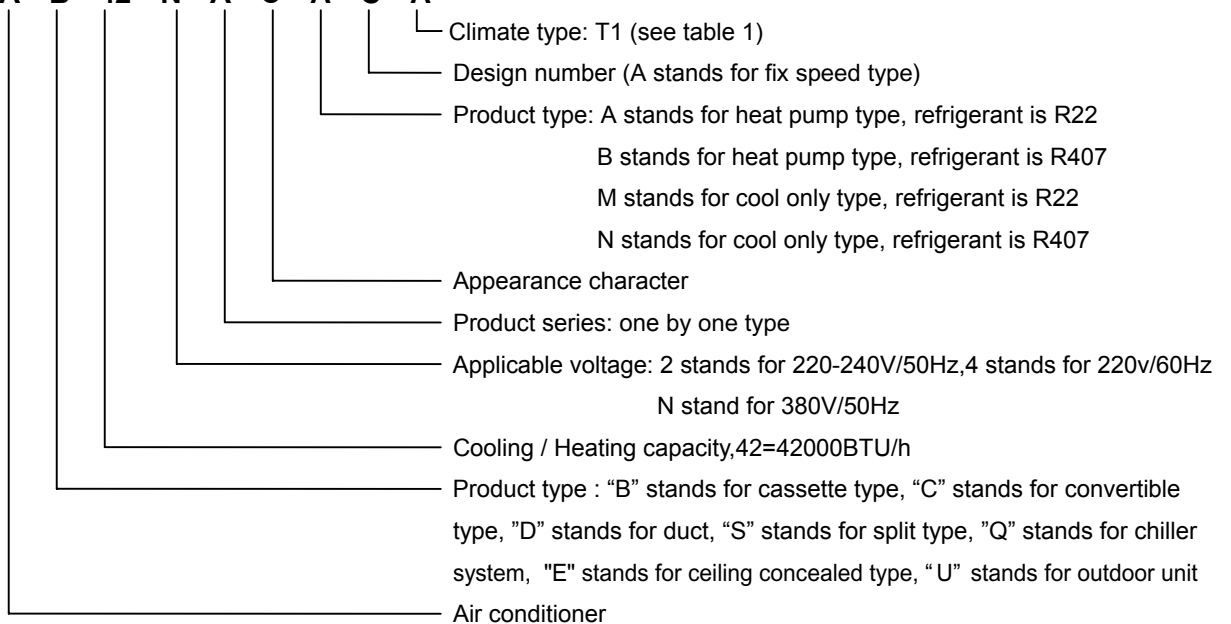

## 1.2 Brief Introduction to T1、T2、T3 working condition

Table 1

Type of Air Conditioner	Climate type		
	T1	T2	T3
Cool only	18°C~43°C	10°C~35°C	21°C~52°C
Heat pump	-7°C~43°C	-7°C~35°C	-7°C~52°C
Electricity heating	~43°C	~35°C	~52°C

## 1.3 Operating Range of air conditioners

Normal condition

Operation	Operation Range Outside / Inside
Cooling	15 <sup>0</sup> C – 43 <sup>0</sup> C
Drying	15 <sup>0</sup> C – 43 <sup>0</sup> C
Heating	-7 <sup>0</sup> C – 18 <sup>0</sup> C

### 1.4 Products characteristic

Completely invisible machine body

The whole machine body is completely concealed inside the ceiling. Due to its compact size it neither breaks the harmonization of indoor decoration nor occupies the indoor spaces. The stylish look of air conditioner allows it to blend right into ceiling.

Superbly efficient healthy filter

Superbly efficient antibiotic materials are utilized and can prevent germs from breeding efficiently.

Flexible and easy installation

Slim design with machine body, completely ceiling concealing and portable shape, all make it greatly easier to install. Moreover, it occupies least constructional spaces, which help to reduce constructional cost prices. It also features a specific drainage system with up to 600mm lift, which allows reducing installation spaces and ensures to drain smoothly. Thanks to its "smudge-free" mobile outlet grill, the ceiling can be protected from pollution effectively and allow the airflow to fit people's comfortable need much more.

Auto-Restart function

When meeting a power failure during running, no matter how long it will be, once the power is restored, air conditioner will automatic restart with the previous status.

Safety and reliable control due to various signal controls

- 1 Inputting with press buttons on the panel
- 2 Inputting with temperature sensors (indoor ambient temperature sensors, indoor coil pipe temperature sensors, outdoor ambient temperature sensors, outdoor coil pipe temperature sensors)
- 3 Piping pressure signals
- 4 Compressor current signals
- 5 Testing signals
- 6 System time-shorten signal
- 7 Water overflowing signal
- 8 Communication signals between indoor unit and front plate or between indoor unit and outdoor unit .

Precise convenient remote-controlling

When using remote-controlling mode, it is comfortable and convenient to operate.

Silent design

The use of radial outward flow turbine fan produces larger cycle airflow volume and acts to significantly decrease operating noise.

## 2 SPECIFICATIONS

Item		Model	HBU-14H03		
Function			Cooling	Heating	
Capacity		BTU/h	14000	16000	
Total power input		W	1500	1500	
EER or COP		BTU/W	9.3	10.6	
Dehumidifying capacity		10 <sup>-3</sup> ×m <sup>3</sup> /h	1		
Power source		PH-V-Hz	1PH, 220V-230V, 50HZ		
Running current/Starting current		A	9.52/48.5	/	
Power cable			/		
Indoor unit	Unit model (color)		AB142ACAAA/ WHITE		
	Fan	Type × Number		CENTRIFUGAL×1	
		Speed	r/min	840/650/560	
		Air-flow(H-M-L)	m <sup>3</sup> /h	830	
	Heat exchanger	Type / Diameter		TP2M/9.52	
		Flow		2/2	
		Total area	m <sup>2</sup>	0.297	
		Temp. scope	°C	2-7	
	Dimension (L×W×H)	External	mm×mm×mm	700×570×276	
		Package	mm×mm×mm	775×715×361	
	Drainage pipe (material , I.D./O.D.)			PVC 25	
	Control type (wireless/wired)			wireless	
	Fresh air hole dimension		mm	/	
Noise level (H-M-L)	dB(A)	41/39/35			
Weight (net / gross)	kg	26/28			
Panel	Dimension (L×W×H)	External	mm×mm×mm		630×630×95
		Package	mm×mm×mm		685×685×155
	Weight (net / gross)	kg	4.2 / 6.3		
Outdoor unit	Unit model (color)		AU142AFABA/ WHITE		
	Compressor	Model / Manufacture		HuaRunQX-26 / HUARUN	
		Type		scroll	
	Fan	Type × Number		Axial-flow×1	
		Speed	r/min	800	
		Air-flow(H-M-L)	m <sup>3</sup> /h	700/-/-	
	Heat exchanger	Type / Diameter		TP2M/9.52	
		Flow		2/2	
		Total area	m <sup>2</sup>	0.534	
		Temp. scope	°C	43-60	
	Dimension (L×W×H)	External	mm×mm×mm	780×250×660	
		Package	mm×mm×mm	907×344×690	
	Drainage pipe (material , I.D./O.D.)			PVC,32	
Refrigerant control method			Capillary		
Defrosting			Auto		
Noise level (H-M-L)	dB(A)	49/-/			
Four way valve			/		
Weight (net / gross)	kg	40/48			
Piping	Refrigerant	Type		R22	
		Charge	kg	1.95	
	Pipe	Liquid	mm	6.35	
		Gas	mm	15.88	
		Connect method		FLARED	
	Between I.U. & O.U.	Drop	m	MAX :5	
Piping length		m	MAX :15		

## SPECIFICATIONS

Item		Model	HBU-18HC03		
Function			Cooling	Heating	
Capacity		BTU/h	18000	21000	
Total power input		W	2000	2000	
EER or COP		BTU/W	9.00	10.5	
Dehumidifying capacity		10 <sup>-3</sup> ×m <sup>3</sup> /h	1		
Power source		PH-V-Hz	1PH, 220V-230V, 50HZ		
Running current/Starting current		A	8/46	/	
Power cable			/		
Indoor unit	Unit model (color)		AB42NACNAA/ WHITE		
	Fan	Type × Number		CENTRIFUGAL×1	
		Speed	r/min	500/450/380	
		Air-flow(H-M-L)	m <sup>3</sup> /h	1050	
	Heat exchanger	Type / Diameter		TP2M/9.52	
		Flow		2/2	
		Total area	m <sup>2</sup>	0.199	
		Temp. scope	°C	-7~43	
	Dimension (L×W×H)	External	mm×mm×mm	750×750×280	
		Package	mm×mm×mm	900×900×420	
	Drainage pipe (material , I.D./O.D.)			PVC 25/32	
	Control type (wireless/wired)			wireless	
	Fresh air hole dimension		mm	/	
Noise level (H-M-L)	dB(A)	43/42/40			
Weight (net / gross)	kg	29/39			
Panel	Dimension (L×W×H)	External	mm×mm×mm		
		Package	mm×mm×mm		
	Weight (net / gross)	kg	3.5/5.8		
Outdoor unit	Unit model (color)		AU42NAINAA / WHITE		
	Compressor	Model / Manufacture		SHW33TC4-U / HITACHI	
		Type	scroll		
	Fan	Type × Number		Axial-flow×1	
		Speed	r/min	820	
		Air-flow(H-M-L)	m <sup>3</sup> /h	700/-/-	
	Heat exchanger	Type / Diameter		TP2M/9.52	
		Flow		2/2	
		Total area	m <sup>2</sup>	0.297	
		Temp. scope	°C	43-60	
	Dimension (L×W×H)	External	mm×mm×mm	810×288×680	
		Package	mm×mm×mm	900×406×760	
	Drainage pipe (material , I.D./O.D.)			PVC,18/20	
	Refrigerant control method			Capillary	
	Defrosting			Auto	
Noise level (H-M-L)	dB(A)	52/-/46			
Four way valve			/		
Weight (net / gross)	kg	58/66			
Piping	Refrigerant	Type	R407C		
		Charge	kg	1.85	
	Pipe	Liquid	mm	6.35	
		Gas	mm	15.88	
		Connect method		FLARED	
	Between I.U. & O.U.	Drop	m	MAX :5	
Piping length		m	MAX :15		

## SPECIFICATIONS

Item		Model	HBU-24H03		
Function			Cooling	Heating	
Capacity		BTU/h	24000	27000	
Total power input		W	2800	2600	
EER or COP		BTU/W	8.57	10.3	
Dehumidifying capacity		10 <sup>-3</sup> ×m <sup>3</sup> /h	3		
Power source		PH-V-Hz	1PH,220V~230V,50Hz		
Running current		A	13/69	13/69	
Power cable			/		
Indoor unit	Unit model (color)		AB242ACAAA/ WHITE		
	Fan	Type × Number		CENTRIFUGAL×1	
		Speed	r/min	700/590/470	
		Air-flow(H-M-L)	m <sup>3</sup> /h	1300	
	Heat exchanger	Type / Diameter		TP2M/9.52	
		Flow		2/2	
		Total area	m <sup>2</sup>	0..326	
		Temp. scope	°C	2-7	
	Dimension (L×W×H)	External	mm×mm×mm	840×840×240	
		Package	mm×mm×mm	910×910×300	
	Drainage pipe (material , I.D./O.D.)			PVC 25/32	
	Control type (wireless/wired)			wireless	
	Fresh air hole dimension		mm	/	
Noise level (H-M-L)	dB(A)	39/37/35			
Weight (net / gross)	kg	28/30			
Panel	Dimension (L×W×H)	External	mm×mm×mm		
		Package	mm×mm×mm		
	Weight (net / gross)	kg	950×950×80		
			980×980×100		
			6/9		
Outdoor unit	Unit model (color)		AU242AHABA/ WHITE		
	Compressor	Model / Manufacture		TI 15HM1529 / Copeland	
		Type		scroll	
	Fan	Type × Number		Axial-flow×1	
		Speed	r/min	840/-/-	
		Air-flow(H-M-L)	m <sup>3</sup> /h	3240	
	Heat exchanger	Type / Diameter		TP2M/9.52	
		Flow		3/3	
		Total area	m <sup>2</sup>	0.62	
		Temp. scope	°C	43-60	
	Dimension (L×W×H)	External	mm×mm×mm	948×830×340	
		Package	mm×mm×mm	1050×979×440	
	Drainage pipe (material , I.D./O.D.)			PVC,18/20	
Refrigerant control method			Capillary		
Defrosting			Auto		
Noise level (H-M-L)	dB(A)	58/-/50			
Four way valve			/		
Weight (net / gross)	kg	74/89			
Piping	Refrigerant	Type	R22		
		Charge	kg	2.5	
	Pipe	Liquid	mm	9.52	
		Gas	mm	15.88	
		Connect method		FLARED	
	Between I.U. & O.U.	Drop	m	MAX :15	
Piping length		m	MAX : 30		

## SPECIFICATIONS

Item		Model	HBU-28HD03	
Function			Cooling	Heating
Capacity		BTU/h	28000	29000
Total power input		W	2800	2600
EER or COP		BTU/W	10.0	11.1
Dehumidifying capacity		10 <sup>-3</sup> ×m <sup>3</sup> /h	3	
Power source		PH-V-Hz	3N,380V~400V,50Hz	
Running current/Starting current			9/62	/
Power cable			/	
Indoor unit	Unit model (color)		AB282ACACA/WHITE	
	Fan	Type × Number		CENTRIFUGAL×1
		Speed	r/min	700/590/470
		Air-flow(H-M-L)	m <sup>3</sup> /h	1300
	Heat exchanger	Type / Diameter		TP2M/9.52
		Flow		2/2
		Total area	m <sup>2</sup>	0.199
		Temp. scope	°C	2-7
	Dimension (L×W×H)	External	mm×mm×mm	840×840×240
		Package	mm×mm×mm	910×910×300
	Drainage pipe (material , I.D./O.D.)			PVC 18/20
	Control type (wireless/wired)			wireless
	Fresh air hole dimension		mm	/
Noise level (H-M-L)	dB(A)	39/37/35		
Weight (net / gross)	kg	28/30		
Panel	Dimension (L×W×H)	External	mm×mm×mm	950×950×80
		Package	mm×mm×mm	980×980×100
	Weight (net / gross)	kg	6/9	
Outdoor unit	Unit model (color)		AU282AHADA/ WHITE	
	Compressor	Model / Manufacture		ZR34K3E-PFJ-522 / Copeland
		Type		scroll
	Fan	Type × Number		Axial-flow×1
		Speed	r/min	840/-/-
		Air-flow(H-M-L)	m <sup>3</sup> /h	3240
	Heat exchanger	Type / Diameter		TP2M/9.52
		Flow		3/3
		Total area	m <sup>2</sup>	0.62
		Temp. scope	°C	43-60
	Dimension (L×W×H)	External	mm×mm×mm	948×830×340
		Package	mm×mm×mm	1050×979×440
	Drainage pipe (material , I.D./O.D.)			PVC,18/20
	Refrigerant control method			Capillary
Defrosting			Auto	
Noise level (H-M-L)	dB(A)	58/-/50		
Four way valve			/	
Weight (net / gross)	kg	70/85		
Piping	Refrigerant	Type	R22	
		Charge	kg	2.5
	Pipe	Liquid	mm	9.52
		Gas	mm	15.88
		Connect method		FLARED
	Between I.U. & O.U.	Drop	m	MAX :15
Piping length		m	MAX : 30	



Type	HBU-36H03	Appearance color (indoor/outdoor unit)	White/white
Cold producing capacity	36000BTU	Heat producing capacity	39000BTU
Cold producing coefficient	2.85w/w	Heat producing coefficient	3.17w/w
Cold producing power	3700W	Heat producing power	3600W
Defrosting capacity	$4.5 \times 10^{-3} \text{ m}^3/\text{h}$	Ratio of energy generating to consuming	-----
New wind capacity	Attached at new air inlet	Negative hydronium quantity of negative hydronium type machine	-----
Operating voltage scope	380-400V	Operating current scope	5.1-9A
Operating temperature scope	-7~43℃	Operating fitting frequency	50HZ
Temperature adjustment difference	1℃	Type of refrigerant	R22
Climate type	T1	Anti-static protection type	I
Indoor unit noises (cold producing)	43/41/39 dB(A)	Outdoor unit noises (cold producing)	High/low 64 dB(A)
Indoor unit noises (heat producing)	----- dB(A)	Outdoor unit noises (heat producing)	High/low ---- dB(A)
External dimension of indoor unit	840x1230x280 mm	External dimension of outdoor unit	948x340x1225 mm
Package dimension of indoor unit	920x1325x370 mm	Package dimension of outdoor unit	1050x440x1375mm
Installation motherboard dimension	See to the installation figure	Layer restriction of laminated indoor and outdoor unit	4/2
Net weight/gross weight of indoor unit	46/53 kg	Net weight/gross weight of outdoor unit	88/108 kg
Maximum installation fall	30m	Current-in side (indoor/outdoor)	-----
Allowable infusing quantity of refrigerant	3200g	Maximum infusing quantity of refrigerant	-----
Cleanout frequency of filter	Once per month	Type of filter (filter screen)	-----
Filtration efficiency	-----	Dimension of filter (filter screen)	-----
Type of air compressor	H23A46QDBEA	Manufacturer of air compressor	Bristol
Oil impouring volume to air compressor	1480cc	Type of air compressor protector	32HM65-112
Cut off valve type	φ 9.52; φ 19.05	Four-way valve type	STF-0408
Dimension of air-in grid shaking flake	-----	Quantity /space of air-in grid shaking flake	4
Length of maximum connecting pipe of unit	50m	Total length of refrigerating pipe circuit (liquid /gas)	-----
Drainage pipe type	PVC	Length/ diameter of drainage pipe	φ 25(inside); φ 32(outside)
Flow value of evaporator and condensator	10/8	Type /diameter of evaporator and condensator pipe	TP2 M φ 9.52; φ 19.05
Total area of evaporator	0.575mm	Total area of condensator	0.92mm
Temperature scope of evaporator	2-7℃	Temperature scope of condensator	43-60℃
Total fin quantity /its row number	2/1320;2/446	Thickness /space of fin	0.11/1.9
Fin coefficient	-----	Fin material kind	Light foil
Type of capillary	TP2 Y	Diameter /length of capillary	-----
Protector type on control panel	3.25A	Temperature sensor type	10K Ω 23K Ω 5K Ω
Real-time adjustment scope	-----	Consumed power capacity	Indoor:130WOutdoor:60x2
Type of accessories on computer board	See to attachment	Type of segregator for gas and liquid	5.0L
Rotating speed of air fan	Indoor: 590/490/420 Outdoor:840	Type /quantity of air fan	Indoor: centrifugal/1 Outdoor:axial-flow/2
Type of muffle	φ 40x2	Kind of adopted noise reduction material	XPE
Type of desiccator	-----	Type of vibration absorbing material	Daub
Air-out grid flake's shaking frequency	-----	Angle /distance of air ventilation	Not adjusted/10m
Maximum work pressure on heated side	2.94Mpa	Maximum work pressure on cooled side	2.94Mpa
Indoor hygrometer temperature	See to Table 1	Outdoor hygrometer temperature	See to Table 1
Authentication certificate held	CE	Antisepsis screen(sterilization screen) type and dimension	Resin screen
Appearance feature of in and outdoor unit of the product	Nice and elegant	Shelter material	Dispersed electro-zinccoated sheet
Product peculiarities	1.Low noise 2.Convenient installation, simple operation	Product functions	See to attachment

## SPECIFICATIONS

Item		Model	HBU-42HD03		
Function			Cooling	Heating	
Capacity		BTU/h	42000	45000	
Total power input		W	4700	4600	
EER or COP		BTU/W	8.9	9.7	
Dehumidifying capacity		10 <sup>-3</sup> ×m <sup>3</sup> /h	5		
Power source		PH-V-Hz	3N, 380V-400V, 50HZ		
Running current/Starting current			9/62		
Power cable			/		
Indoor unit	Unit model (color)		AB42NACNAA/ WHITE		
	Fan	Type × Number		CENTRIFUGAL×3	
		Speed	r/min	980/880/820	
		Air-flow(H-M-L)	m <sup>3</sup> /h	2040	
	Heat exchanger	Type / Diameter		TP2M/9.52	
		Flow		3/3	
		Total area	m <sup>2</sup>	0.199	
		Temp. scope	°C	2-7	
	Dimension (L×W×H)	External	mm×mm×mm	840×1230×280	
		Package	mm×mm×mm	910×1320×300	
	Drainage pipe (material , I.D./O.D.)			PVC 25/32	
	Control type (wireless/wired)			wireless	
	Fresh air hole dimension		mm	/	
	Noise level (H-M-L)	dB(A)	43/41/39		
Weight (net / gross)	kg	46/53			
Panel	Dimension (L×W×H)	External	mm×mm×mm		
		Package	mm×mm×mm		
	Weight (net / gross)	kg	8.4/12		
Outdoor unit	Unit model (color)		AU42NAINAA / WHITE		
	Compressor	Model / Manufacture		H23A62QDBEA / Bristol	
		Type		scroll	
	Fan	Type × Number		Axial-flow×2	
		Speed	r/min	840/-/-	
		Air-flow(H-M-L)	m <sup>3</sup> /h	6000	
	Heat exchanger	Type / Diameter		TP2M/9.52	
		Flow		5/5	
		Total area	m <sup>2</sup>	0.92	
		Temp. scope	°C	43-60	
	Dimension (L×W×H)	External	mm×mm×mm	948×1225×340	
		Package	mm×mm×mm	1050×1375×440	
	Drainage pipe (material , I.D./O.D.)			PVC,25/32	
	Refrigerant control method			Capillary	
Defrosting			Auto		
Noise level (H-M-L)	dB(A)	64/-/-			
Four way valve			/		
Weight (net / gross)	kg	85/111			
Piping	Refrigerant	Type	R22		
		Charge	kg	3.82	
	Pipe	Liquid	mm	9.52	
		Gas	mm	19.05	
		Connect method		FLARED	
	Between I.U. & O.U.	Drop	m	MAX :30	
Piping length		m	MAX : 50		

### 3 SAFETY PRECAUTIONS

- Please read these "Safety Precautions" first then accurately execute the installation work.
- Though the precautionary points indicated herein are divided under two headings, **△WARNING** and **△CAUTION** those points which are related to the strong possibility of an installation done in error resulting in death or serious injury are listed in the **△WARNING** section. However, there is also a possibility of serious consequences in relationship to the points listed in the **△CAUTION** section as well. In either case, important safety related information is indicated, so by all means, properly observe all that is mentioned.
- After completing the installation, along with confirming that no abnormalities were seen from the operation tests, please explain operating methods as well as maintenance methods to the user (customer) of this equipment, based on the owner's manual.

Moreover, ask the customer to keep this sheet together with the owner's manual.

#### **△ WARNING**

- This system should be applied to places of office, restaurant, residence and the like. Application to inferior environment such as engineering shop could cause equipment malfunction.
- Please entrust installation to either the company which sold you the equipment or to a professional contractor. Defects from improper installations can be the cause of water leakage, electric shocks and fires.
- Execute the installation accurately, based on following the installation manual. Again, improper installations can result in water leakage, electric shocks and fires.
- When a large air-conditioning system is installed to a small room, it is necessary to have a prior planned countermeasure for the rare case of a refrigerant leakage, to prevent the exceeding of threshold concentration. In regards to preparing this countermeasure, consult with the company from which you purchased the equipment, and make the installation accordingly. In the rare event that a refrigerant leakage and exceeding of threshold concentration does occur, there is the danger of a resultant oxygen deficiency accident.
- For installation, confirm that the installation site can sufficiently support heavy weight. When strength is insufficient, injury can result from a falling of the unit.
- Execute the prescribed installation construction to prepare for earthquakes and the strong winds of typhoons and hurricanes, etc. Improper installations can result in accidents due to a violent falling over of the unit.
- For electrical work, please see that a licensed electrician executes the work while following the safety standards related to electrical equipment, and local regulations as well as the installation instructions, and that only exclusive use circuits are used.  
Insufficient power source circuit capacity and defective installment execution can be the cause of electric shocks and fires.
- Accurately connect wiring using the proper cable, and insure that the external force of the cable is not conducted to the terminal connection part, through properly securing it. Improper connection or securing can result in heat generation or fire.
- Take care that wiring does not rise upward, and accurately install the lid/service panel. Its improper installation can also result in heat generation or fire.

### △ WARNING

- When setting up or moving the location of the air conditioner, do not mix air etc. or anything other than the designated refrigerant (please see nameplate) within the refrigeration cycle.
- Rupture and injury caused by abnormal high pressure can result from such mixing.  
Always use accessory parts and authorized parts for installation construction. Using parts not authorized by this company can result in water leakage, electric shock, fire and refrigerant leakage.
- The position of indoor unit must be above the floor 2.5m.

### △ CAUTION

- Execute proper grounding. Do not connect the ground wire to a gas pipe, water pipe, lightning rod or a telephone ground wire.  
Improper placement of ground wires can result in electric shock.
- The installation of an earth leakage breaker is necessary depending on the established location of the unit. Not installing an earth leakage breaker may result in electric shock.
- Do not install the unit where there is a concern about leakage of combustible gas.  
The rare event of leaked gas collecting around the unit could result in an outbreak of fire.
- For the drain pipe, follow the installation manual to insure that it allows proper drainage and thermally insulate it to prevent condensation. Inadequate plumbing can result in water leakage and water damage to interior items.

## 4 NET DIMENSIONS OF INDOOR AND OUTDOOR UNIT

Model: HBU-14H03 Indoor unit

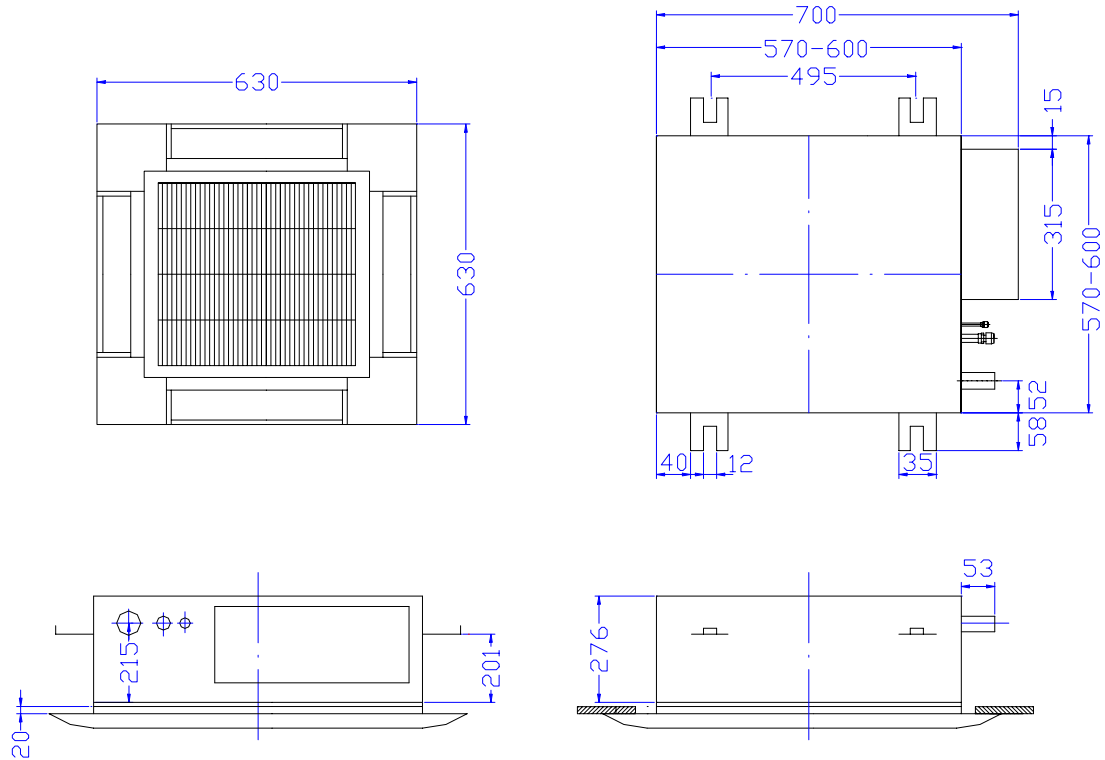

Model: HBU-14H03 Outdoor unit

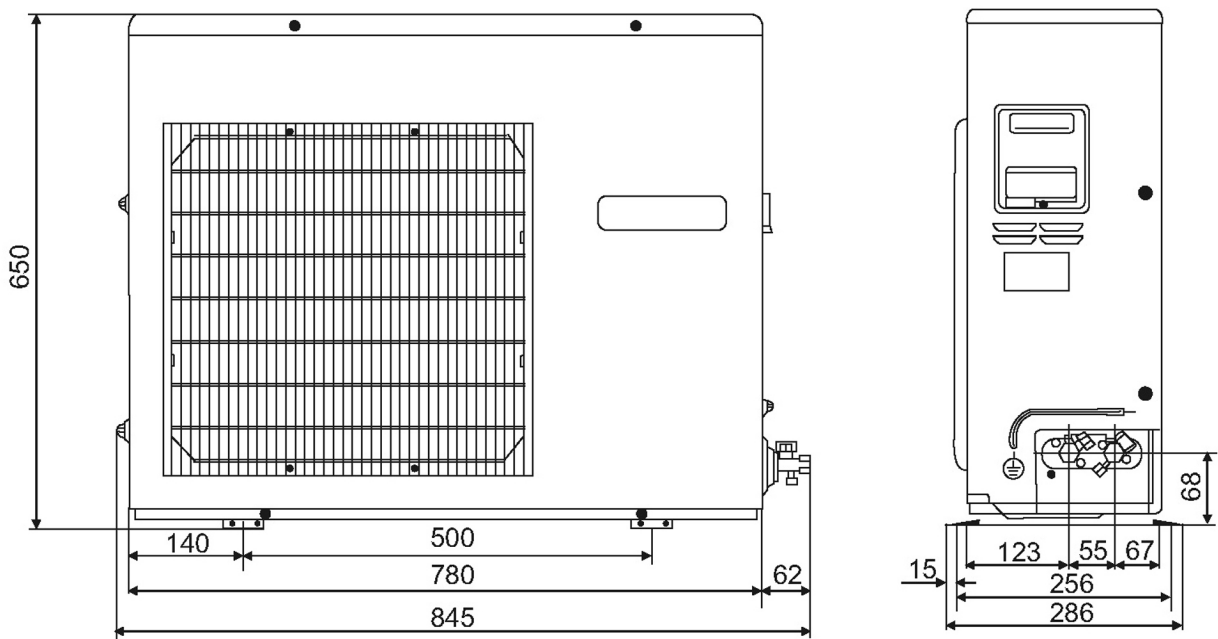

# NET DIMENSIONS OF INDOOR AND OUTDOOR UNIT

Model: HBU-18HC03 Indoor unit

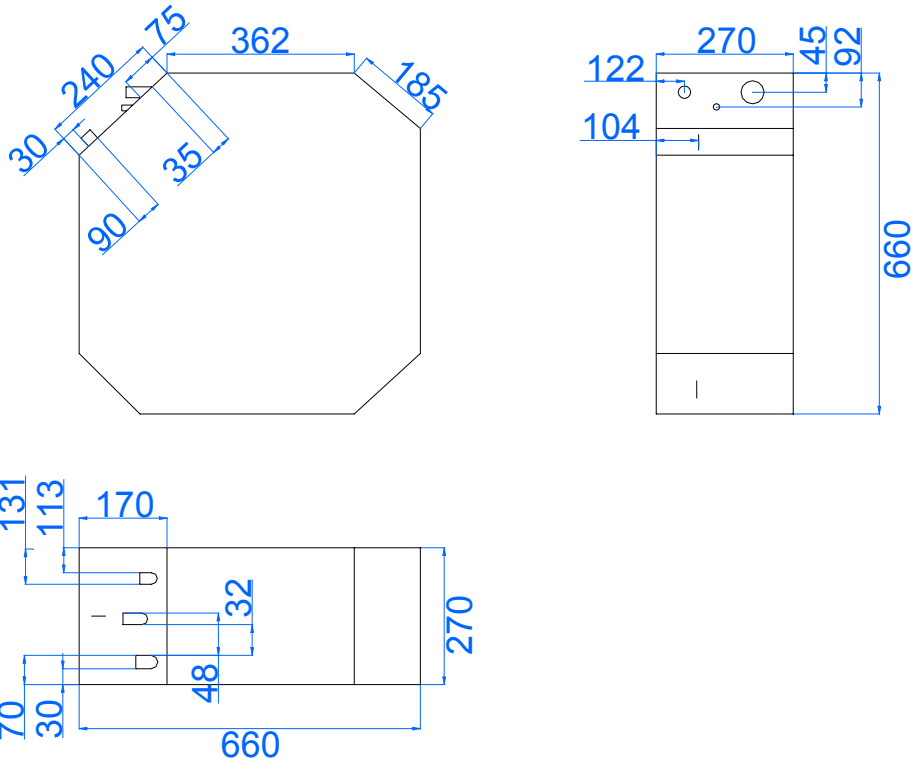

Model: HBU-18HC03 Outdoor unit

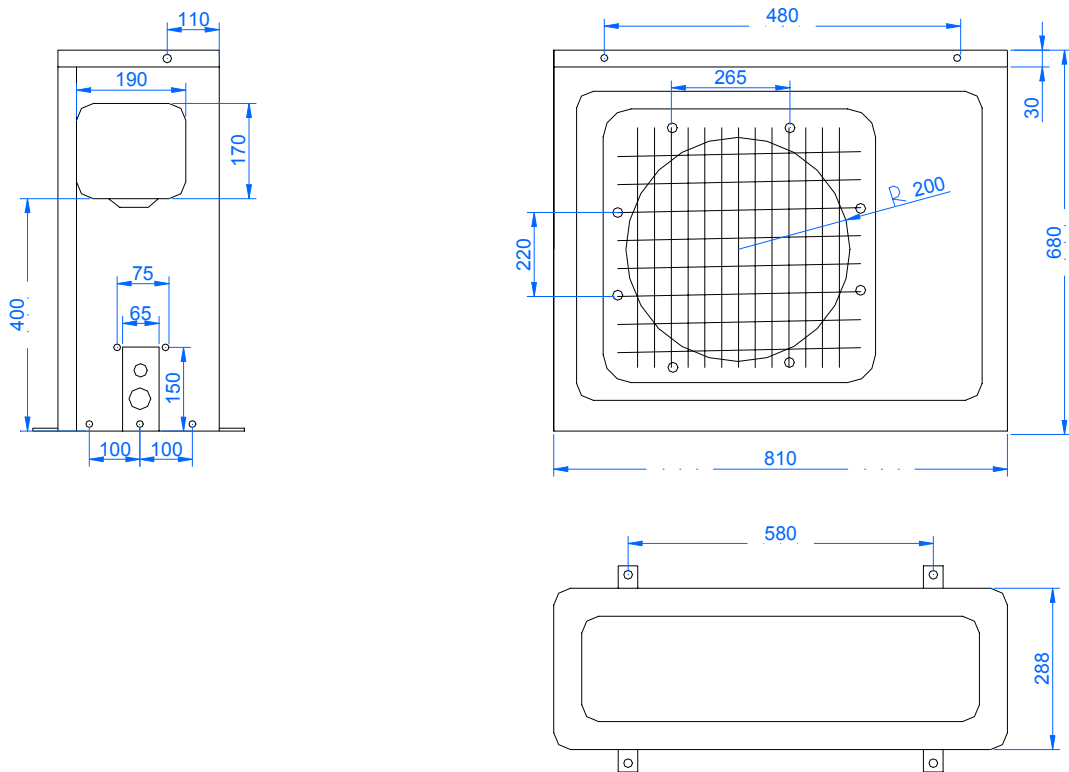

# NET DIMENSIONS OF INDOOR AND OUTDOOR UNIT

Model: HBU-24H03 HBU-28HD03 Indoor unit

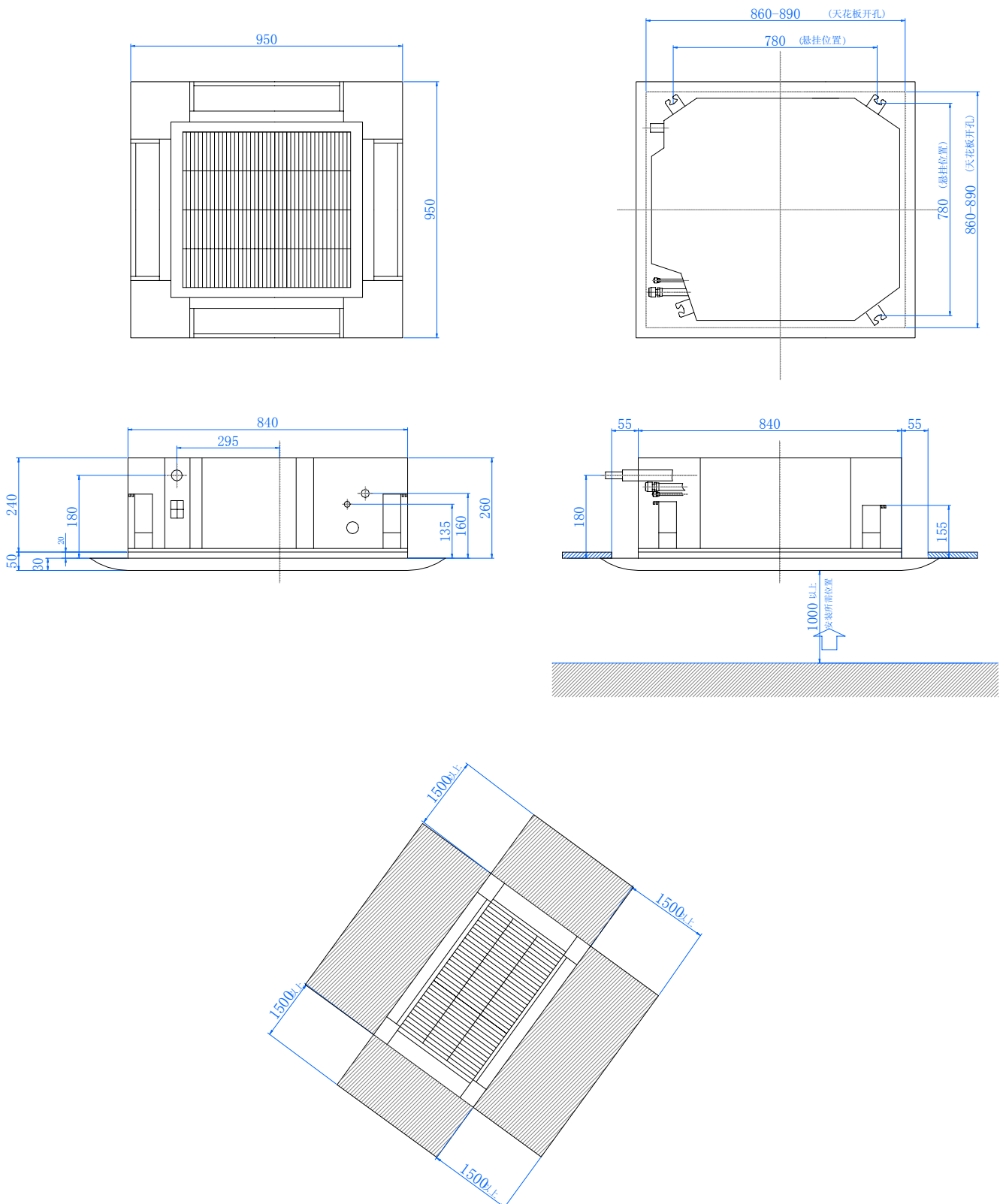

# NET DIMENSIONS OF INDOOR AND OUTDOOR UNIT

Model: HBU-24H03 HBU-28HD03 Outdoor unit

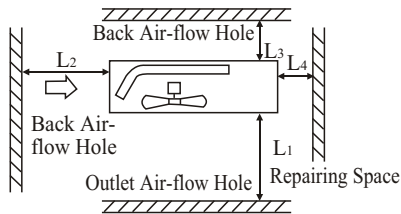
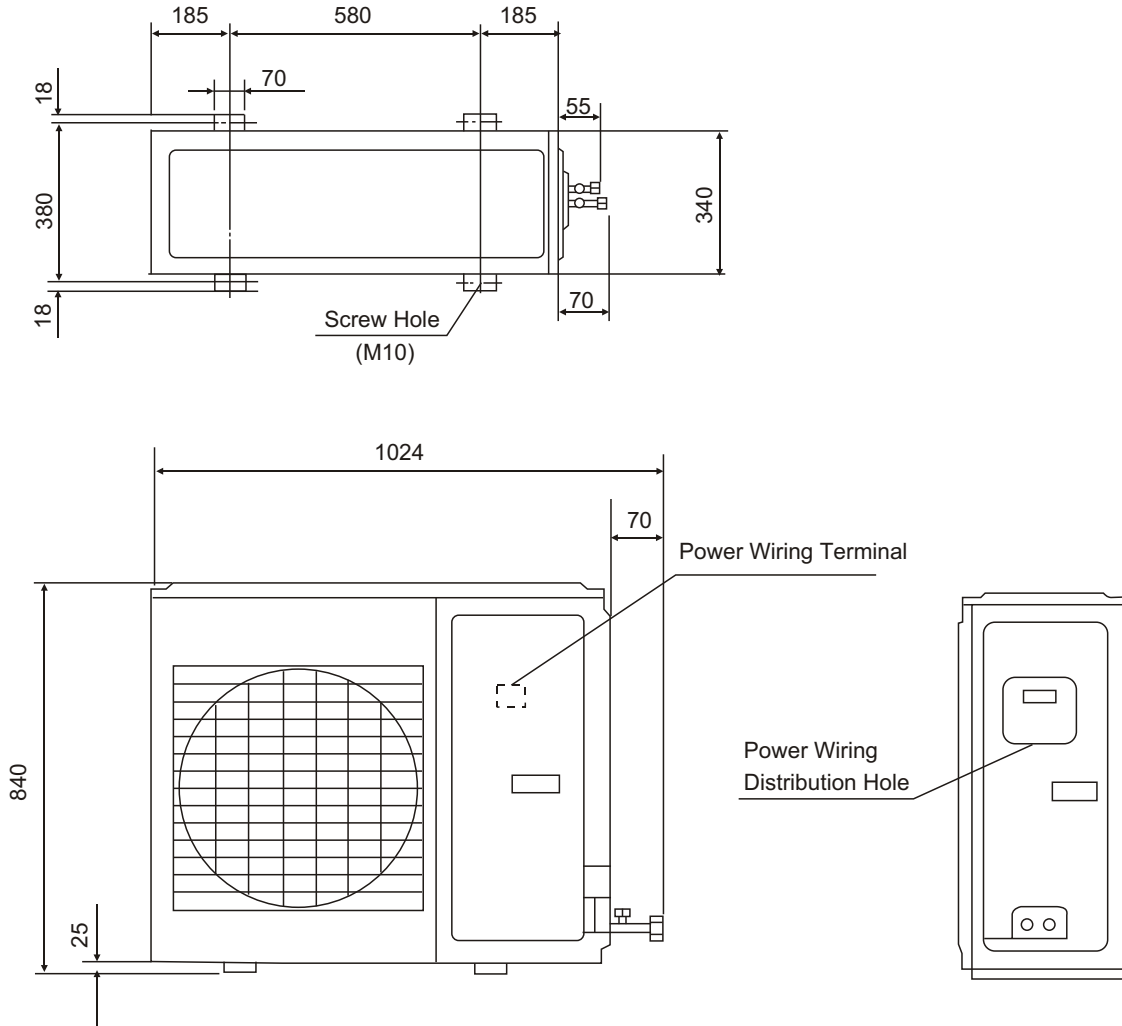

- Note (1) Fix the parts with screws  
 (2) Don't intake the strong wind directly to the outlet air-flow hole.  
 (3) A one meter distance should be kept from the unit top  
 (4) Don't block the surroundings of the unit with sundries.

Installation Servicing Space(at Least)

Unit:mm

Installation Dimension	Installation		
	I	II	III
L <sub>1</sub>	Leave space	Leave space	500
L <sub>2</sub>	300	0	Leave space
L <sub>3</sub>	100	150	100
L <sub>4</sub>	0	0	0



# NET DIMENSIONS OF INDOOR AND OUTDOOR UNIT

Model: HBU-36H03 HBU-42HD03 Indoor unit

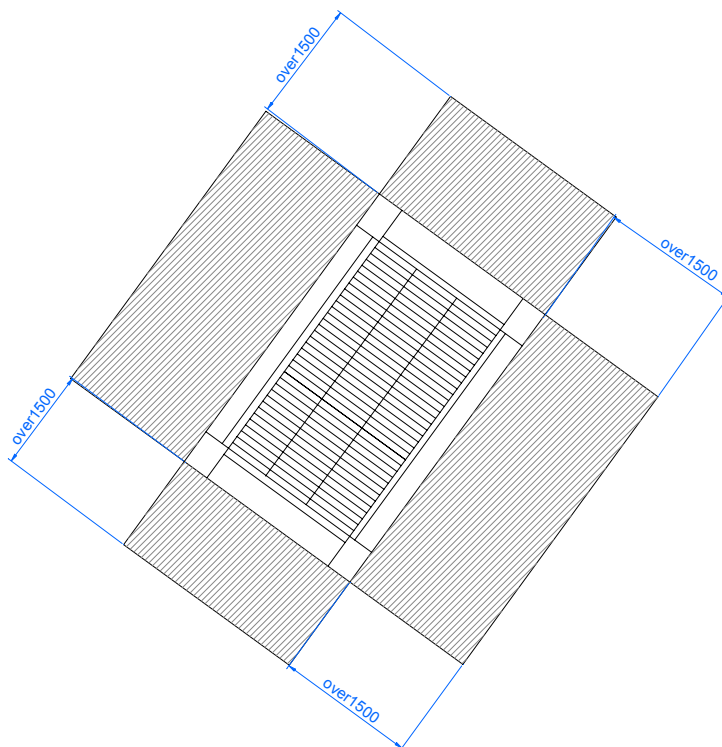
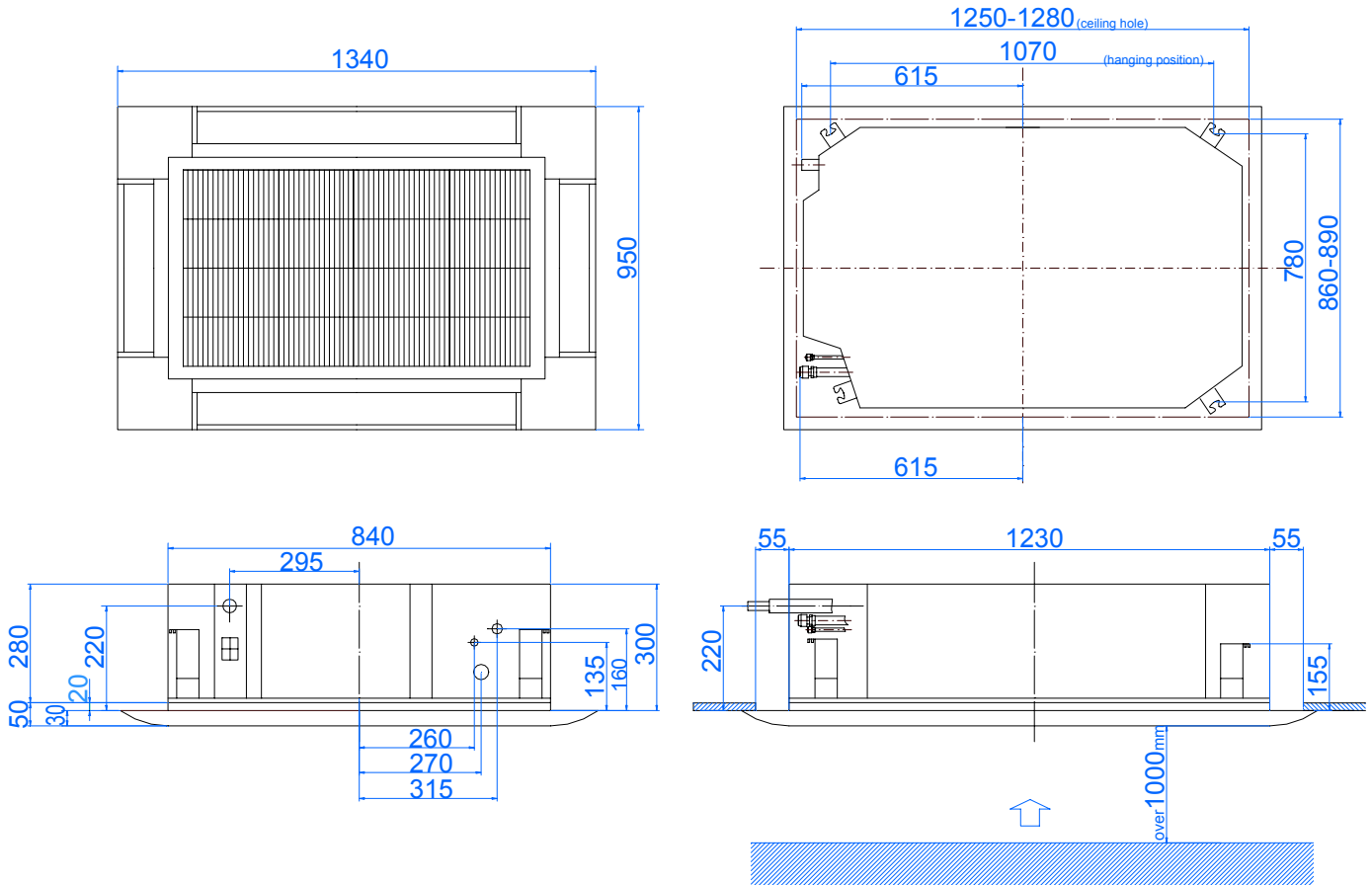

# NET DIMENSIONS OF INDOOR AND OUTDOOR UNIT

Model: HBU-36H03 HBU-42HD03 Outdoor unit

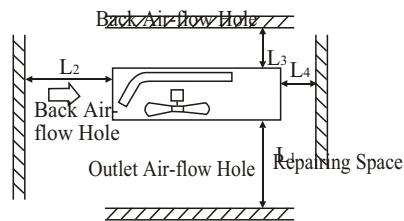
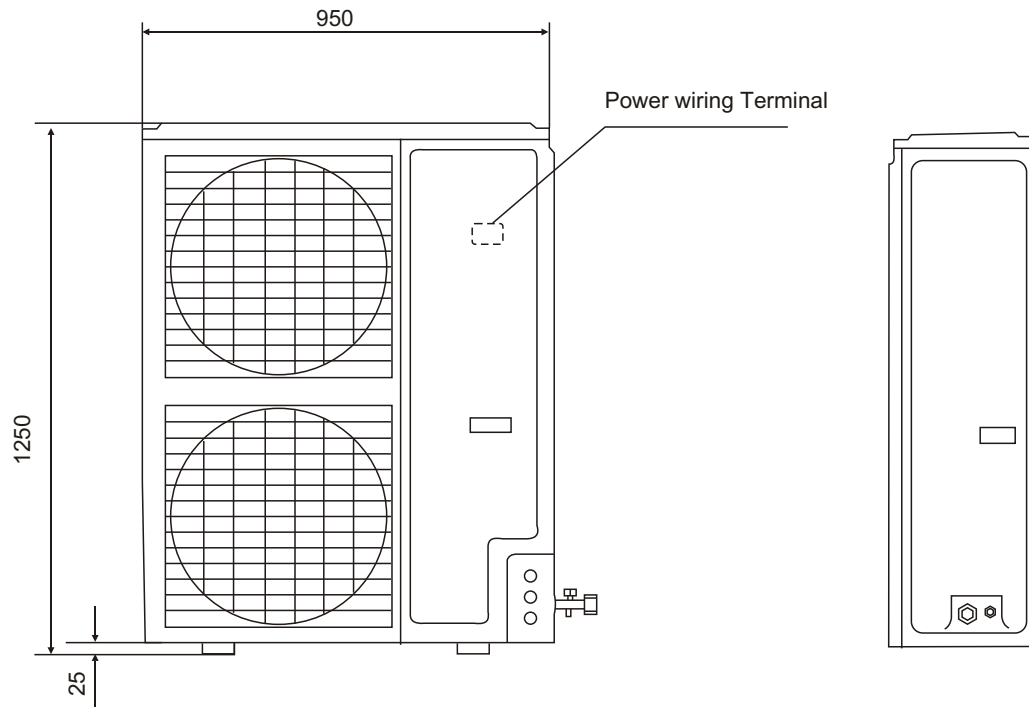
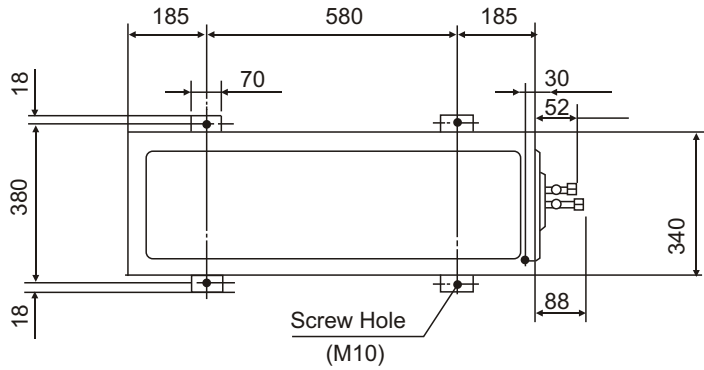

- Note :
- (1). Fix the parts with screws
  - (2). Don't intake the strong wind directly to the outlet air-flow hole.
  - (3). A one meter distance should be kept from the unit top
  - (4). Don't block the surroundings of the unit with sundries

Installation Servicing Space(at Least)

		Unit:mm		
Dimension	Installation	I	II	III
	L <sub>1</sub>	Leave space	Leave space	500
L <sub>2</sub>	300	0	Leave space	
L <sub>3</sub>	100	150	100	
L <sub>4</sub>	0	0	0	







## 5 INSTALLATION INSTRUCTIONS







### 5.1 Installation tools

1. Cross screwdriver 2 .Metal saw 3 .60,70mm drill 4. Inner hexagon spanner, shifting spanner 5 .Spanner(14, 17, 19,24,27mm diameter) 6. Pipe cutter  
7. Pipe expander 8. Knife 9 .Pliers 10. Leak detector or soap liquor  
11. Measuring tape 12 .Scraper 13. Refrigeration oil 14 .Vacuum pump  
15 .Flat screwdriver

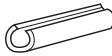
### 5.2 Standard accessories

Please check if your unit is delivered with following

Part name	① Clamp	② Washer	③ Clamp	④ Drain hose	⑤ Paper pattern	⑥ Screw(M5 size)
QTY	2 Piece	8 Piece	6 Piece	1 Piece	1 Set	3 Piece
Shape						For installation of paper pattern 

Part name	⑦ Insulator	⑧ Insulator	⑨ Dry battery	⑩ Sealing pad	⑪ Sealing pad	⑫ Sealing pad	[Other] ● Operation Manual ● Ornament panel ● Remote controller
QTY	1 Piece	1 Piece	2 Piece	1 Piece	1 Piece	2 Piece	
Shape	For gas pipe 	For liquid pipe 	R03, 7# 	Large size 	Medium size 	Small size 	

### 5.3 Installation of indoor unit

#### 5.3.1 Before installation

- Determine the way to carry unit to installation place.
- Don't remove packing until unit reaches installation place.  
If unpacking is unavoidable, protect unit properly.

#### 5.3.2 Selection of installation place

(1) Installation place shall meet the following and agreed by customers:

- Place where proper air flow can be ensured.
- No block to air flow.
- Water drainage is smooth.
- Place strong enough to support unit weight.
- Place where inclination is not evident on ceiling.
- Enough space for maintenance.
- Indoor and outdoor unit piping length is within limit. (Refer to Installation Manual for outdoor unit.)
- Indoor and outdoor unit, power cable, inter unit cable are at least 1 m away from T.V. radio. This is helpful to avoid picture disturbance and noise. (Even if 1 m is kept, noise can still appear if radio wave is strong)

- (2) Ceiling height  
Indoor unit can be installed on ceiling of 2.5-3m in height. (Refer to ⑧ Field setting and Installation Manual of ornament panel.)
- (3) Install suspending bolt. Check if the installation place is strong enough to hold weight. Take necessary measures in case it is not safe. (Distance between holes are marked on paper pattern. Refer to paper pattern for place need be reinforced)

Installation space

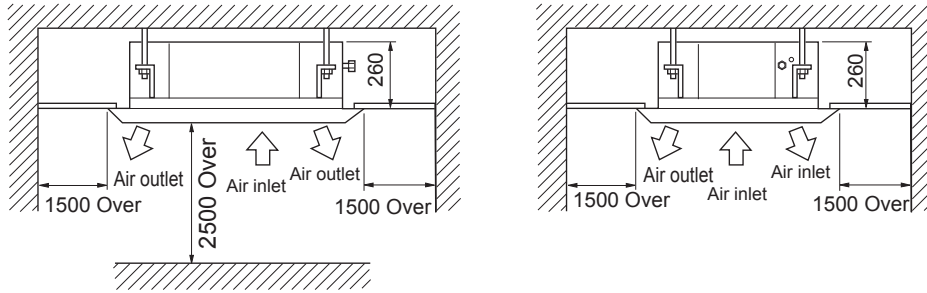

### 5.3.3 Preparation

- (1) Position of ceiling opening between unit and suspending bolt. Unit: mm

HBU-14

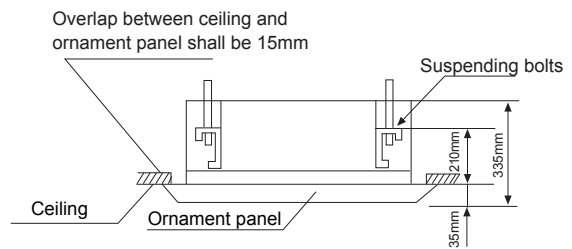
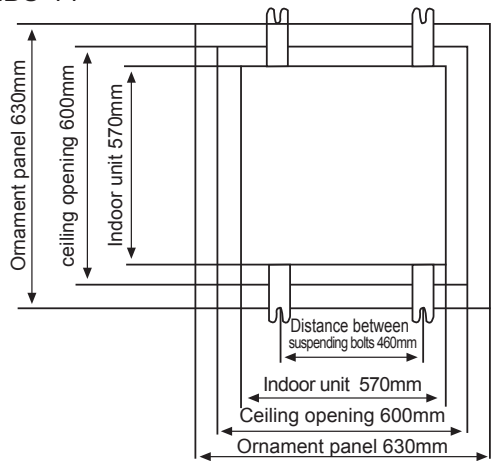

HBU-18

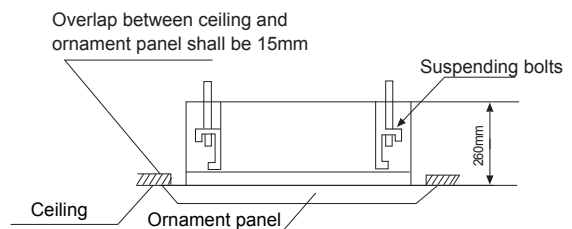
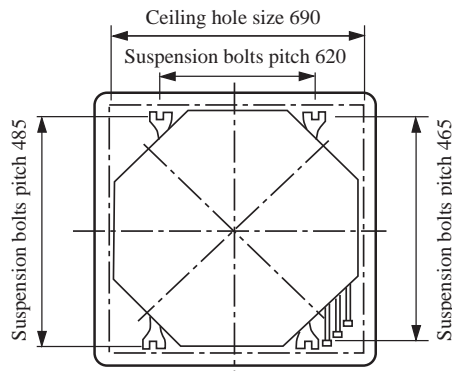

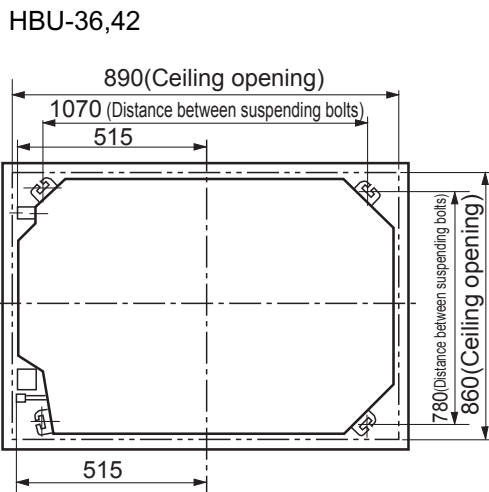
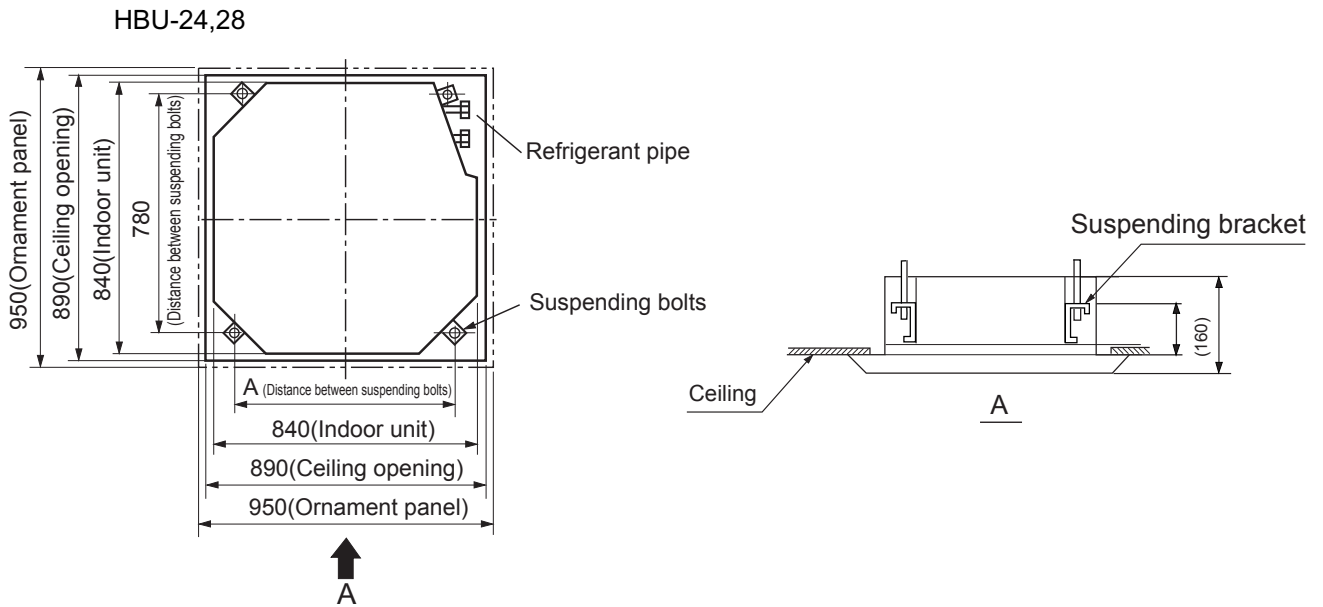

Note:  
 Dimension of ceiling opening marked with \* can be as large as 910mm, but the matching part of ceiling with ornament panel shall be over 20mm.

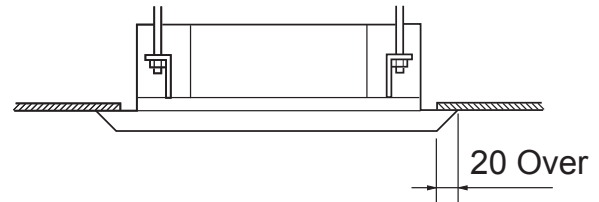

(2) Cut an opening in ceiling for installation if necessary. (when ceiling already exists.)

- Refer to paper pattern for dimension of ceiling hole.
- Connect all pipings (refrigerant, water drainage), wirings (inter unit cable) to indoor unit, before installation.
- Cut a hole in ceiling, may be a frame should be used to ensure a smooth surface and to prevent vibration. Contact your real estate dealer

(3) Install a suspending bolt.

(Use a M10 bolt)

To support the unit weight, anchor bolt shall be used in the case of already exists ceiling. For new ceiling, use built-in type bolt or parts prepared in the field.

Before going on installing adjust space between ceiling.

<Installation example>

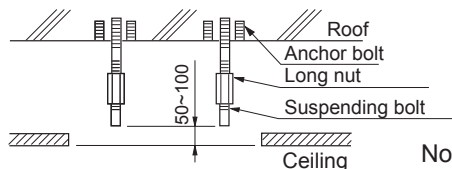

Note: All the above mentioned parts shall be prepared in field.

## 5.3.4 Installation

### In the case of new ceiling

(1) Install unit temporarily

- Put suspending bracket on the suspending bolt. Be sure to use nut and washer at both ends of the bracket.

(2) ● As for the dimensions of ceiling hole, see paper pattern. Ask your real estate dealer for details.

- Center of the hole is marked on the paper pattern.
- Center of the unit is marked on the card in the unit and on the paper pattern.

- Mount paper pattern ④ onto unit using 3 screws ⑤. Fix the corner of the drain pan at piping outlet.

< After installation on the ceiling >

(3) Adjust unit to its right position. (Refer to preparation for the installation-(1))

(4) Check unit's horizontal level.

- Water pump and flating switch is installed inside indoor unit, check four corners of the unit for its level using horizontal compartor or PVC tube with water. (If unit is tilting against the direction of water drainage, problem may occur on floating switch, causing water leakage.)

(5) Remove the washer mounlting ⑦, and tighten the nut above.

(6) Remove the paper pattern.

### In the case of ceiling already exists

(1) Install unit temporarily

- Put suspending bracket on the suspending bolt. Be sure to use nut and washer at both ends of the bracket. Fix the bracket firmly.

(2) Adjust the height and position of the unit. (Refer to preparation for the installation (1) ).

(3) Proceed with ③ and ④ of "In the case of new ceiling".

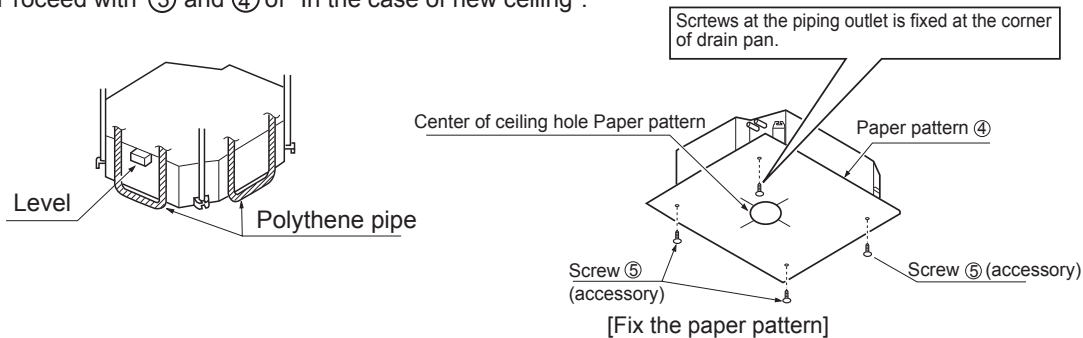

## 5.3.5 Refrigerant piping

As for outdoor piping, please refer to installation Manual of outdoor unit.

- Outdoor is precharged with refrigerant.
- Be sure to see the Fig.1, when connecting and removing piping from unit.
- For the size of the flare nut, please refer to Table 1.
- Apply refrigerant oil at both inside and outside of flare nut. Tighten it band tight 3-4 turns then tighten it.
- Use torque specified in Table 1. (Too much force may damage flare nut, causing gas leakage).
- Check piping joints for gas leakage. Insulate piping as shown in Fig. below.
- Cover joint of gas piping and insulator ⑥ with seal ⑨.

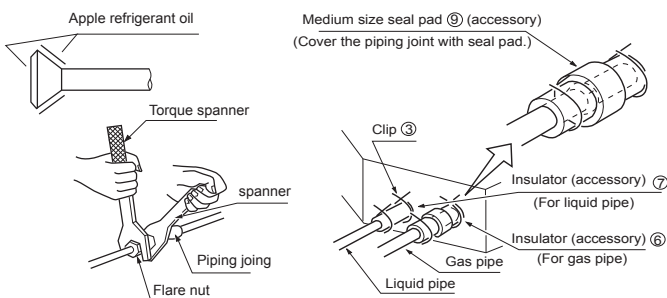

Table 1

Pipe size	Tighten torque	A(mm)	Flare shape
φ 9.52	3270~3990N·cm (333~407kgf·cm)	12.0~12.4	
φ 15.88	6180~7540N·cm (630~770kgf·cm)	18.6~19.0	
φ 19.05	9720~11860N·cm (990~1210kgf·cm)	22.9~23.3	
Diameter of Pipe		Tighten Torque	
Liquid Pipe 6.35mm		18N·m	
Gas Pipe 12.7mm		50N·m	

## 5.3.6 Installation of drainage pipe

### (1) Install water drainage pipe

- Pipe dia, shall be equal or larger than that of unit piping.(pipe of polyethylent; size: 25mm; O.D:32mm)
- Drain pipe should be short, with a downward slope at least 1/100 to prevent air bag from happening.
- If downward slope can't be made, take other measures to lift it up.
- Keep a distance of 1-1.5m between suspending brackets, to make water hose straight.

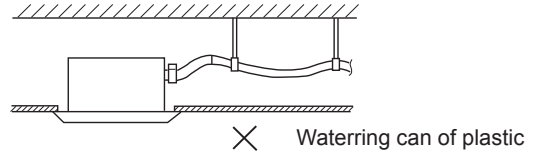
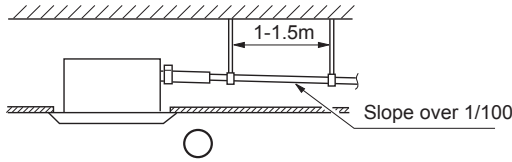

- Use the self-provided stiff pipe and clip ② with unit. Insert water pipe into water plug until it reaches the white tape. Tighten the clip until head of the screw is less than 4mm from hose.
- Wind the drain hose to the clip using seal pad ⑧. Insulate drain hose in the room.

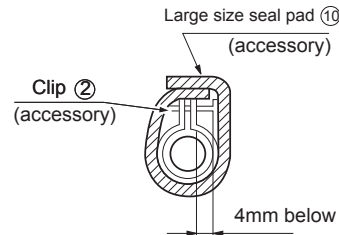
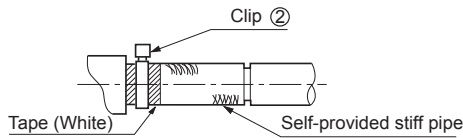

### <Cautions for the drain water lifting pipe>

- Installation height shall be less than 280mm.
- There should be a right angle with unit, 300mm from unit.

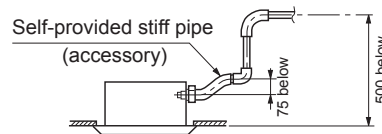
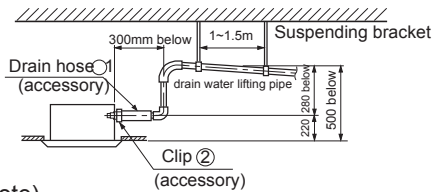

### (Note)

- The slope of water drain hose (1) shall be within 75mm, don't apply too much force on it.
- If several water hoses join together, do as per following procedures.

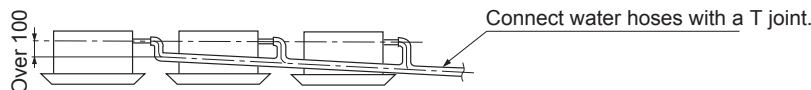

Specifications of the water hoses shall meet the requirements for the unit running.

### (2) Check if water drainage is smooth after installation.

- Charge, through air outlet or inspecting hole, 1200ccd water to see water drainage.

#### After wiring

- Check water drainage in cooling operation. See also ⑪ test run.

#### When wiring is not complete

- Remove cover of control box, short connect "CHECK" terminal of the indoor unit, which is on the upper part of indoor unit PCB. Connect 1PH power to terminal 1 and 2 on terminal block.
- Note, in this operation, fan will be running.
- Upon confirmation of a smooth water drainage, be sure to cut off power supply and remove short connection of "CHECK" terminal.

### Method of water charging

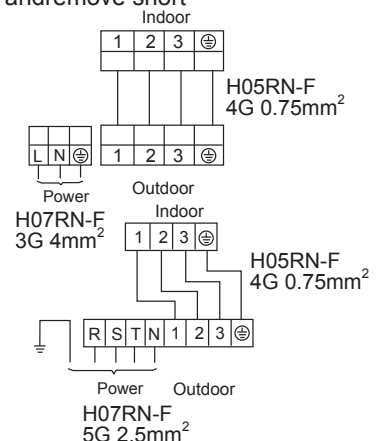
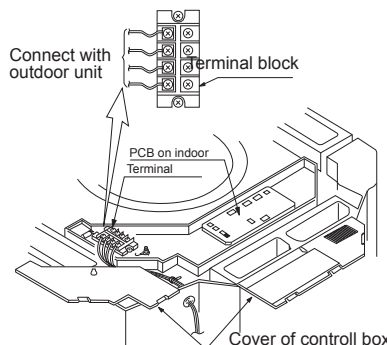
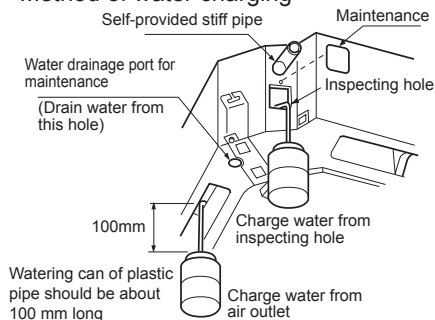

## 5.3.7 Wiring

- All supplied parts, materials and wiring operation must in appliance with local code and regulations.
- Use copper wire only.
- When make wiring, please refer to wiring diagram also.
- All wiring work must be done by qualified electricians.
- A circuit breaker must be installed, which can cut power supply to all system.
- See Installation Manual of outdoor unit for specifications of wires, circuit breaker, switches and wiring etc.
- Connecting of unit  
Remove cover of switch box (1), drag wires into rubber tube A, then, after proper wiring with other wires, tighten clamp A. Connect wires of correct pole to the terminal block inside.
- Wind seal (12) around wires. (Be sure to do that, or, dew may occur).
- Upon connecting, replace control box cover (1) and (2).

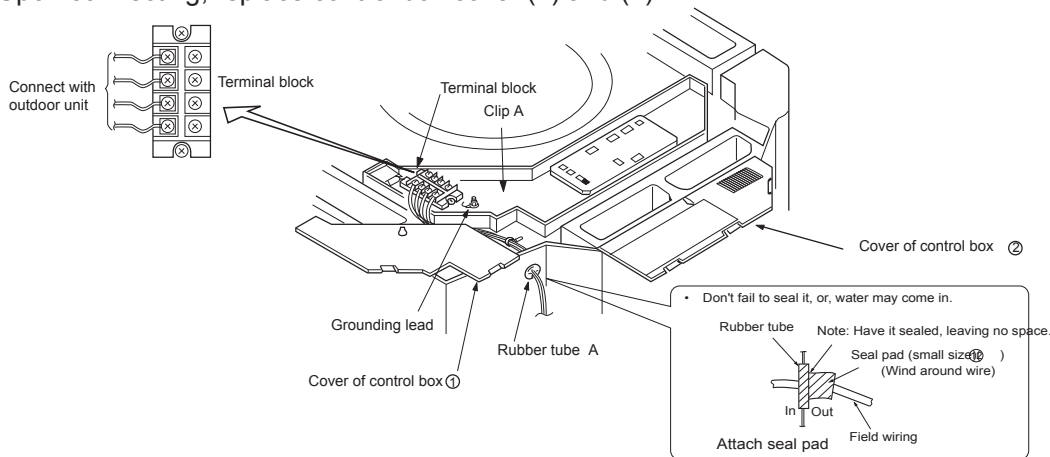

### <<WARNING>>

Observe the following when connecting power supply terminal block. Don't connect wires of different specifications to the same terminal block. (Loose wire may cause overheating of circuit) Connect wires of same specifications as shown in right Fig.

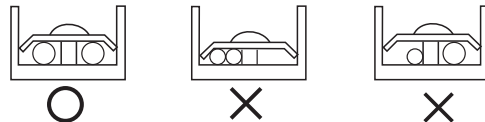

## 5.3.8 Wiring example

As for outdoor unit circuit, please see Installation Manual of outdoor unit.

Note: All electric wires have their own poles, poles must match that on terminal block.

## 5.3.9 Installation of ornament panel

### Cautions for the installation

- Be sure to show customers Operation Manual and guide them how to operate unit correctly. Before installation, read also the Installation Manual of indoor unit.
- With this ornament, 2 or 3 air flow direction is not available. Suitable height is 3 m.

Accessory Pad

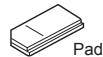

1. Prepare ornament panel  
Handling of ornament panel

- Ornament panel shall not be placed face down or against wall, neither on an uneven object.
- Don't bend carelessly the swing flap, or, problem may occur.

(1) Remove air inlet grill from ornament panel:

- ① Push in the bar on inlet grill and lift it up. (Refer to Fig. 1)
- ② Lift it up for about 45 degree and remove it from ornament.  
Tear off adhesive tape fixing air filter on the back of the air inlet grill. (Refer to Fig. 2)

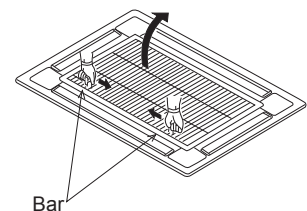



- (2) Remove cover plate at corner  
Tear off the adhesive tape,  
and slide it off.  
(Refer to Fig. 3)

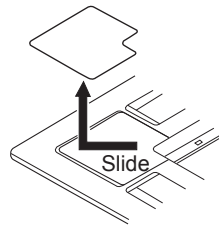

Fig. 3

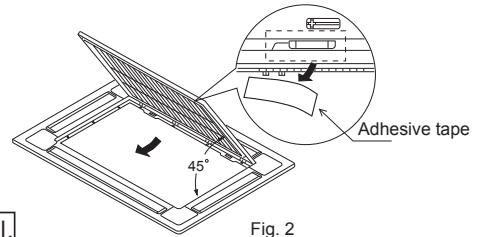

Fig. 2

## 2. Install ornament panel on indoor unit.

For indoor unit installation, please refer to Installation Manual.

- (1) As shown in Fig. 7, match the position of swing flap motor with that of the indoor unit piping hole, so that ornament panel can be placed on to indoor unit.
- (2) Installation of ornament panel
  - ① Place the holding ring on swing flap motor side temporarily on hooks of the indoor unit. (2 pcs)
  - ② Put the other two holding rings on the hooks at both side of the indoor unit. (Care should be taken not to push wiring of swing flap motor into seals).
  - ③ Screw in all 4 screws under holding ring for about 15mm. (Panel will rise).
  - ④ Adjust the ornament panel as per Fig. 7 to cover opening on the ceiling.
  - ⑤ Tighten screws to reduce the thickness of seals between ornament and indoor unit to 5-8mm.

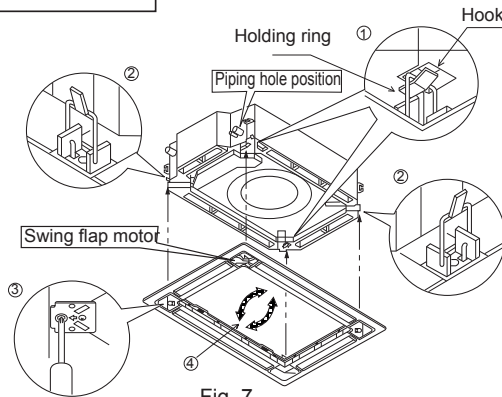
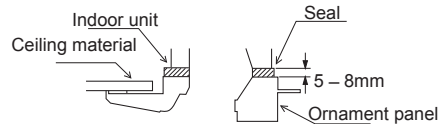

Fig. 7



### Caution

If screws are not tight, problems in Fig. 8 might occur. Tighten screws properly.

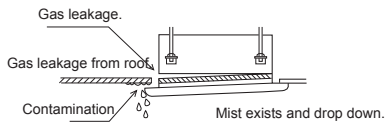

Fig. 8

If there are still space after tightening of screws, please readjust the height of indoor unit. (Refer to Fig. 9)

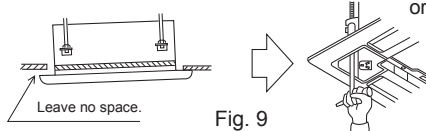

Fig. 9

If indoor unit is at horizontal level and water drainage is smooth, then, indoor unit height can be adjusted through holes at corners of ornament panel.

## 3. Mounting on high ceiling

- (1) Ornament panel can be mounted on ceiling as high as 3 m.
- (2) Please install pad as accessory.
  - ① Cut open the pad along cutting line. Use part (a) only and discard part (b). (Refer to Fig. 4)
  - ② Install part a of the pad on the place shown in Fig. 5. Refer to Fig. 6.

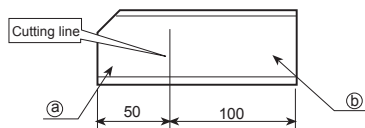

Fig. 4

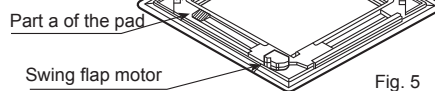

Fig. 5

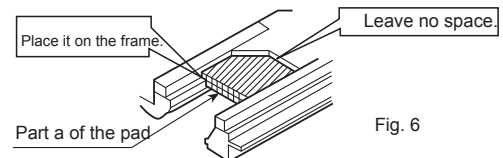

Fig. 6

- (3) Wiring on ornament panel  
Connecting of wiring of the swing flap motor on ornament panel. (2 places)  
(Refer to Fig. 10)

If connecting is not made, error code (A7) appears on remote controller. So, make proper connecting.

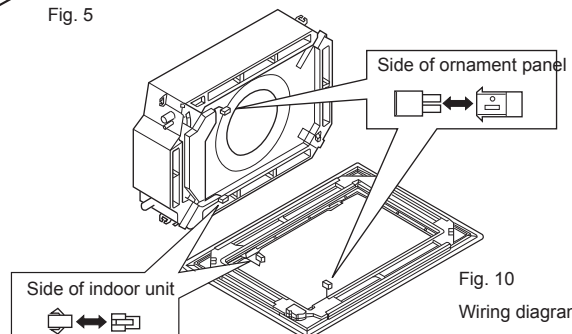

Fig. 10

Wiring diagram

## 4. Installation of inlet grill and cover plate

### (1) Installation of inlet grill

Install in reversed order of "Prepare ornament panel".

Inlet grill can be adjusted into four directions by turning inlet grill. Inlet grill position can be adjusted as per customers request.

When installing inlet grill, take care not to twist wiring of swing flap motor.

### (2) Install cover plate on the corner

- ① As shown in Fig. 11 tie the cover plate onto the bolt on ornament plate.
- ② Install cover plate onto ornament plate. (Refer to Fig. 12)

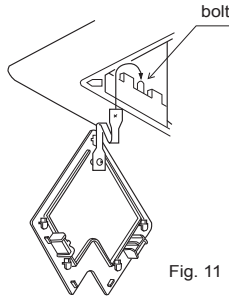

Fig. 11

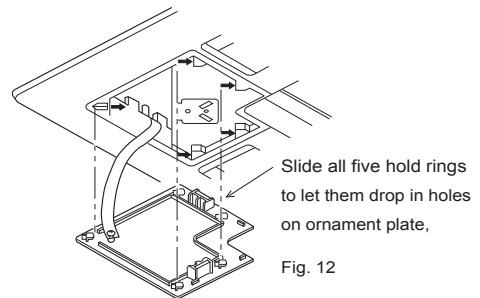

Fig. 12

## 5.3.10 Test running

Refer to

Take special care during installation, check after working

- Upon installation of piping, water drainage and wiring work, make test run to ensure proper unit operation.

Conduct test run after installation of ornament panel

Procedure	Operation
(1)	Open check valve on gas pipe.
(2)	Open check valve on liquid pipe.
(3)	Press ON/OFF button, select Cooling mode.
(4)	Let it run for 3 min.
(5)	Press air flow adjust button to make unit run properly
(6)	Confirm unit functions according to Operation Manual.

Conduct test run before installing ornament panel

Procedure	Operation
(1)	Open check valve on gas pipe.
(2)	Open check valve on liquid pipe.
(3)	Press ON/OFF button, select Cooling mode.
(4)	Let it run for 3 min.
(5)	Cut main power supply after operation.

Note:

If unit doesn't run due to certain problem, please see "Note to unit maintenance".

## 5.4 Installation of outdoor unit

### 5.4.1 Selection of installation place

- Place strong enough to support the unit and will not cause vibration and noise.
- Place where discharged wind and noise do not cause a nuisance to the neighbors.
- Place where is less affected by rain or direct sunlight and is sufficiently ventilated, or to install a shield.
- Place with enough space for smooth air flow.
- The unit shall not be installed on an unspecified metal frame (e.g. theft guard net).
- If the outdoor unit is installed close to a street, it shall be no less than 2.5m from the ground.

### 5.4.2 Fixing of the unit

- Fix outdoor unit using M10 bolt to concrete floor horizontally.
- If installed on the wall or on top of a roof, bracket should be fixed securely to resist earthquake or storms.
- Use rubber pad during installation against unit vibration.
- Install the unit so that the angle of inclination must be less than 3 degrees.

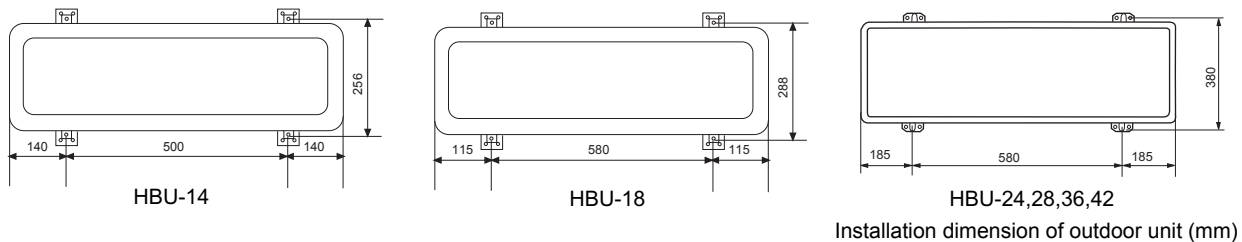

### 5.4.3 Air purging method: To use vacuum pump

For those models which adopt R407C refrigerant shall only use vacuum pump to purge air.

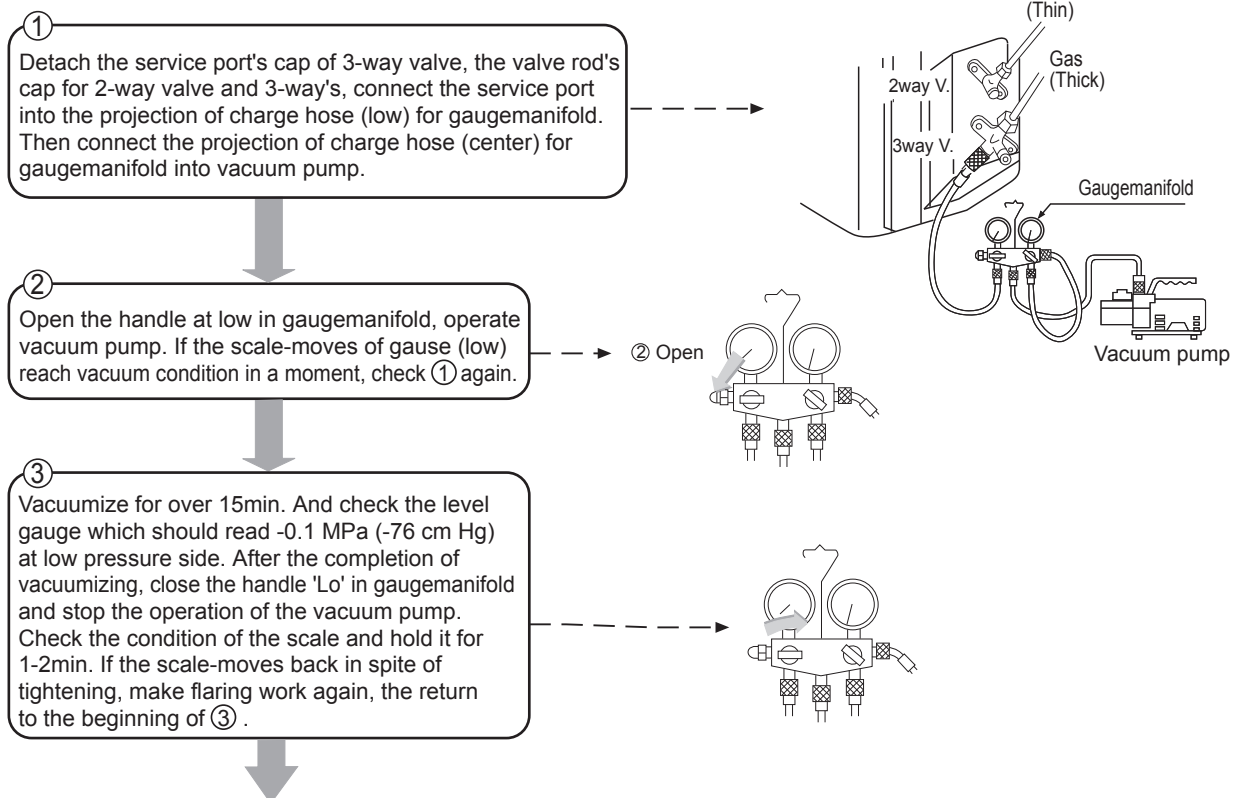

## INSTALLATION INSTRUCTIONS

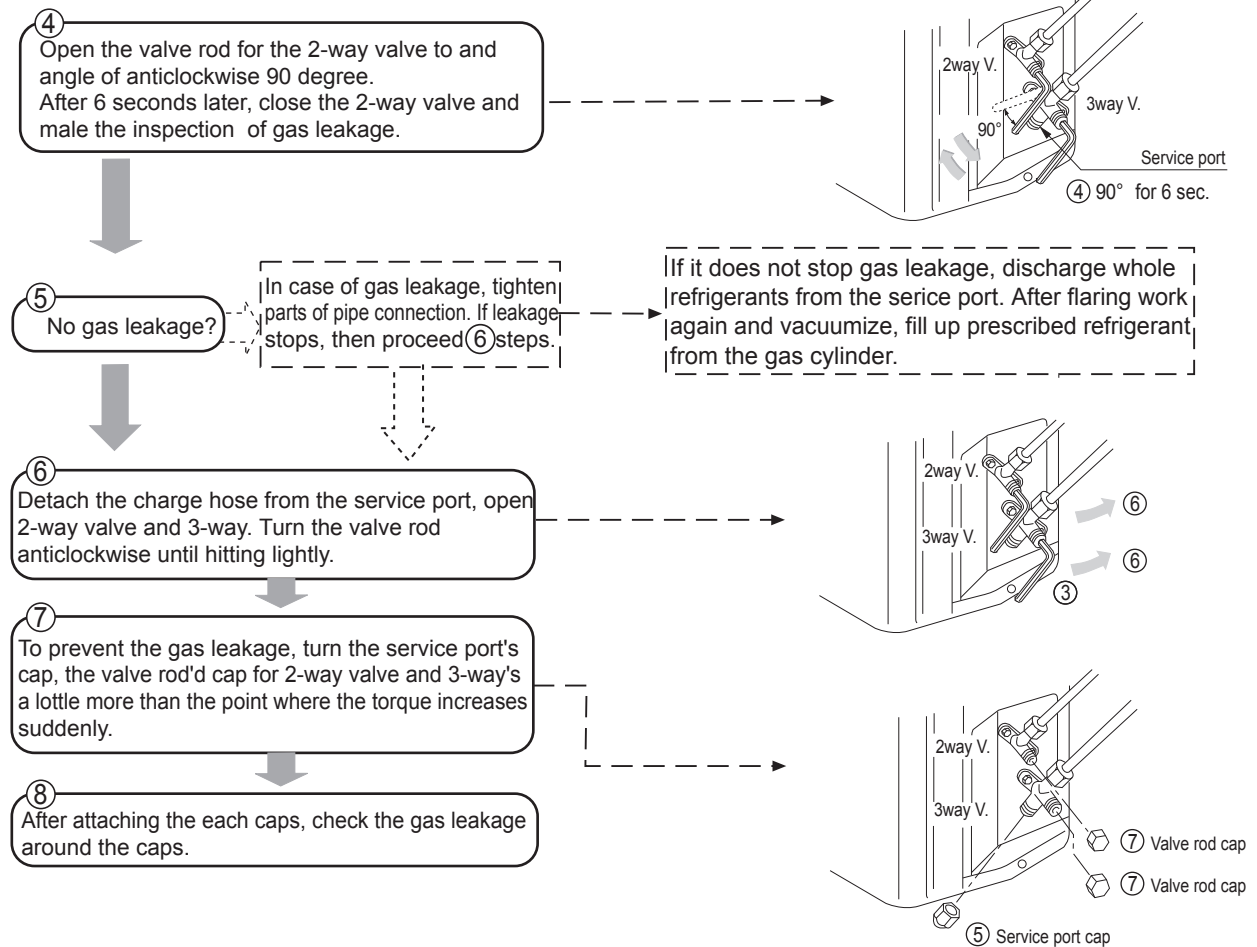

If needing to remove the refrigerant gas when installation or repair , please refer to the following procedures:

1. Cut off the power
2. (After confirming the power is cut off) pull the power cable plug terminals of the low-pressure pressure-switch out.
3. (After confirming the power cable terminals of the low-pressure pressure-switch is cut off) After powering on the unit again and switch to COOLING mode, perform refrigerant gas removing according to the normal refrigerant gas removing procedure.
4. After finishing refrigerant gas removing , cut off the power , then insert the power cable terminals of the low-pressure pressure-switch properly.

**5.5** Pay special care to the following and check after installation

Item to the checked	Unproper installation may cause	Check
Is indoor unit firmly installed?	Unit might fall down, make vibration or noise.	
Is gas leakage check performed?	This may lead to gas shortage.	
Is unit properly insulated?	Dew or water drop may occur.	
Is water drainage smooth?	Dew or water drop may occur.	
Is power voltage meet that stipulated on the nameplate?	Problem may occur or parts got burned.	
Is wiring and piping correctly arranged?	Problem may occur or parts got burned.	
Is unit safely grounded?	There might be a danger of electric shock.	
Is wire size correct?	Problem may occur or parts got burned.	
Are there any obstacles on air inlet and outlet grill of indoor and outdoor unit?	This may cause poor cooling.	
Is record made for piping length and refrigerant charging amount?	It is hard to control refrigerant charging amount.	

6 PARTS AND FUNCTIONS

6.1 Drawings

Indoor unit

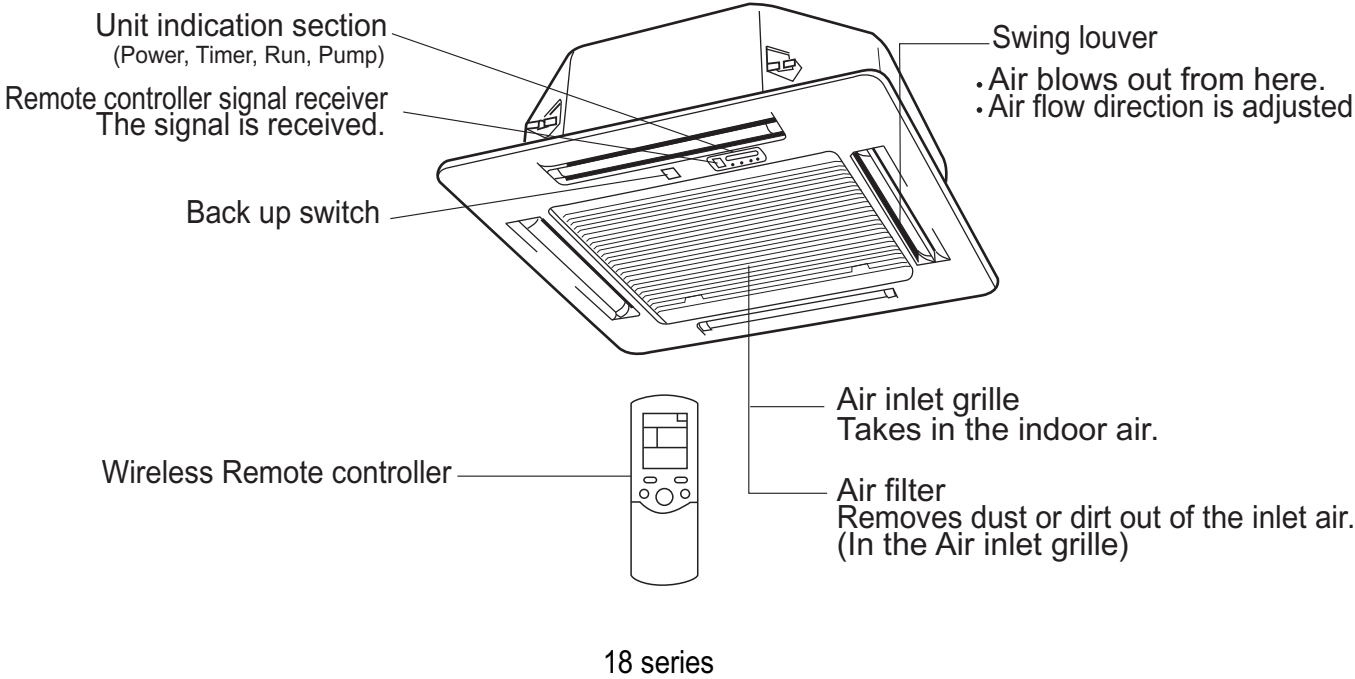
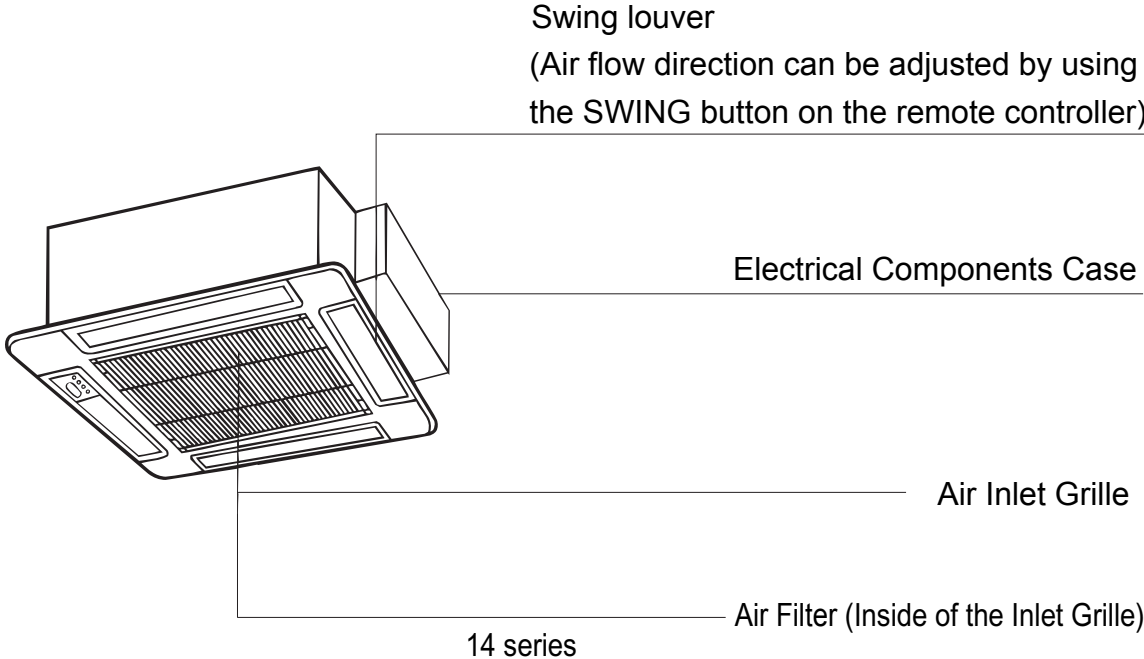

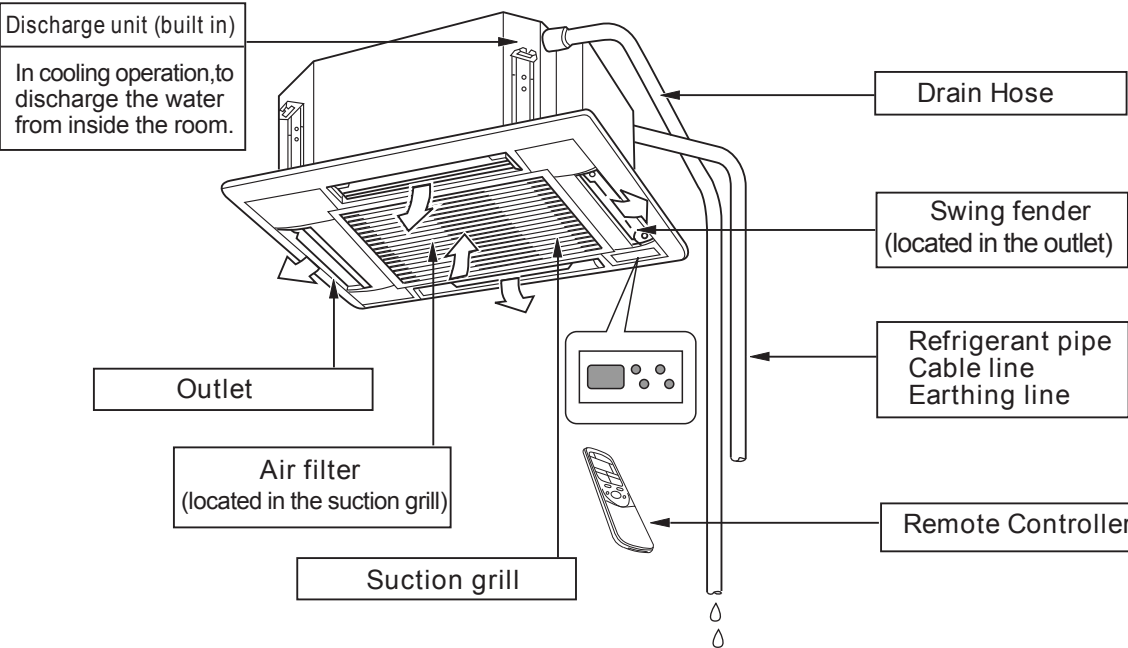

24,28,36,42 series

**Outdoor unit**

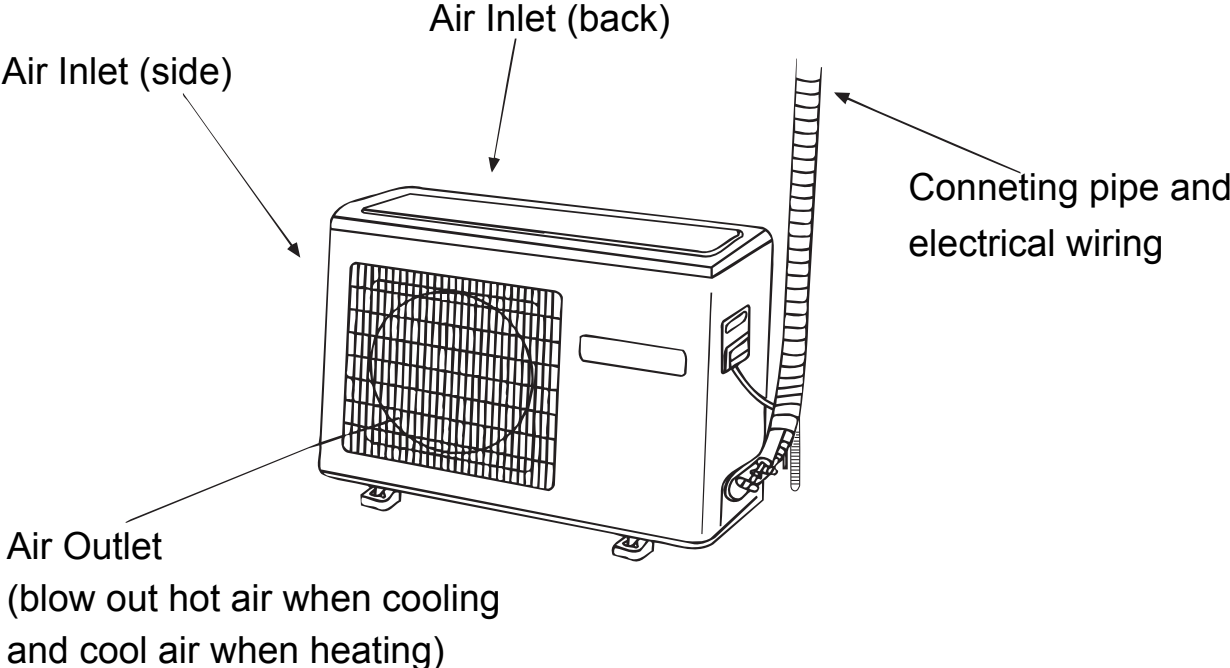

14 series

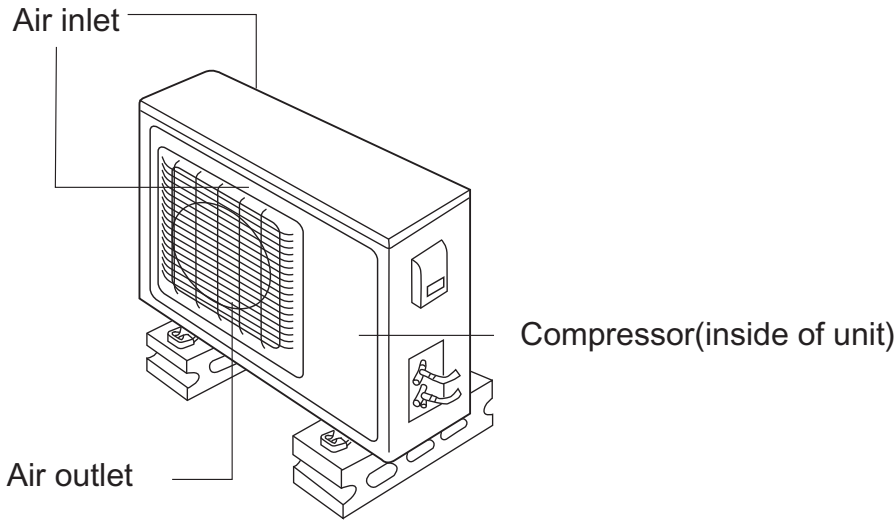

18 series

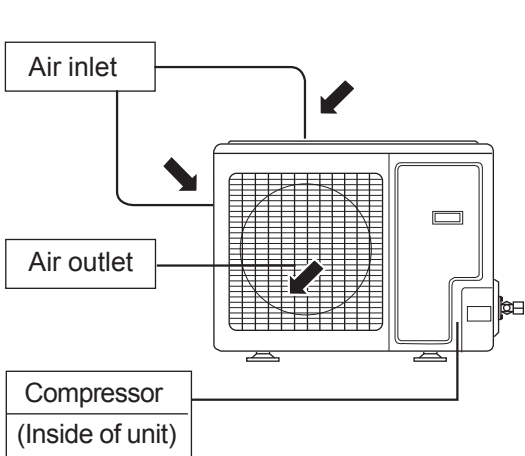

For series 24, 28

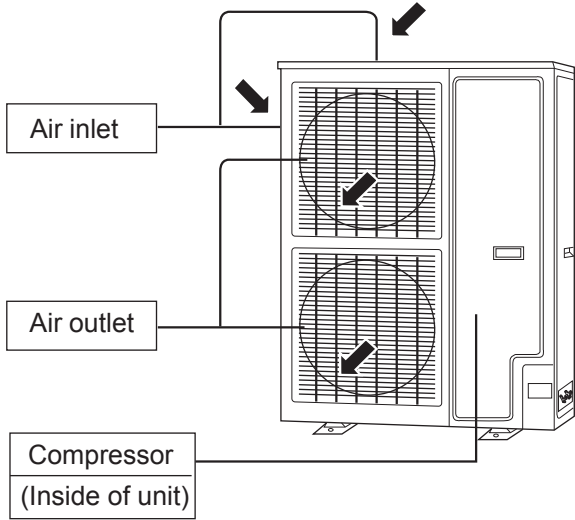

For series 36, 42



## 7 REMOTE CONTROLLER FUNCTIONS

### INTRODUCTION TO SPARE PARTS

Buttons and display of the remote controller.

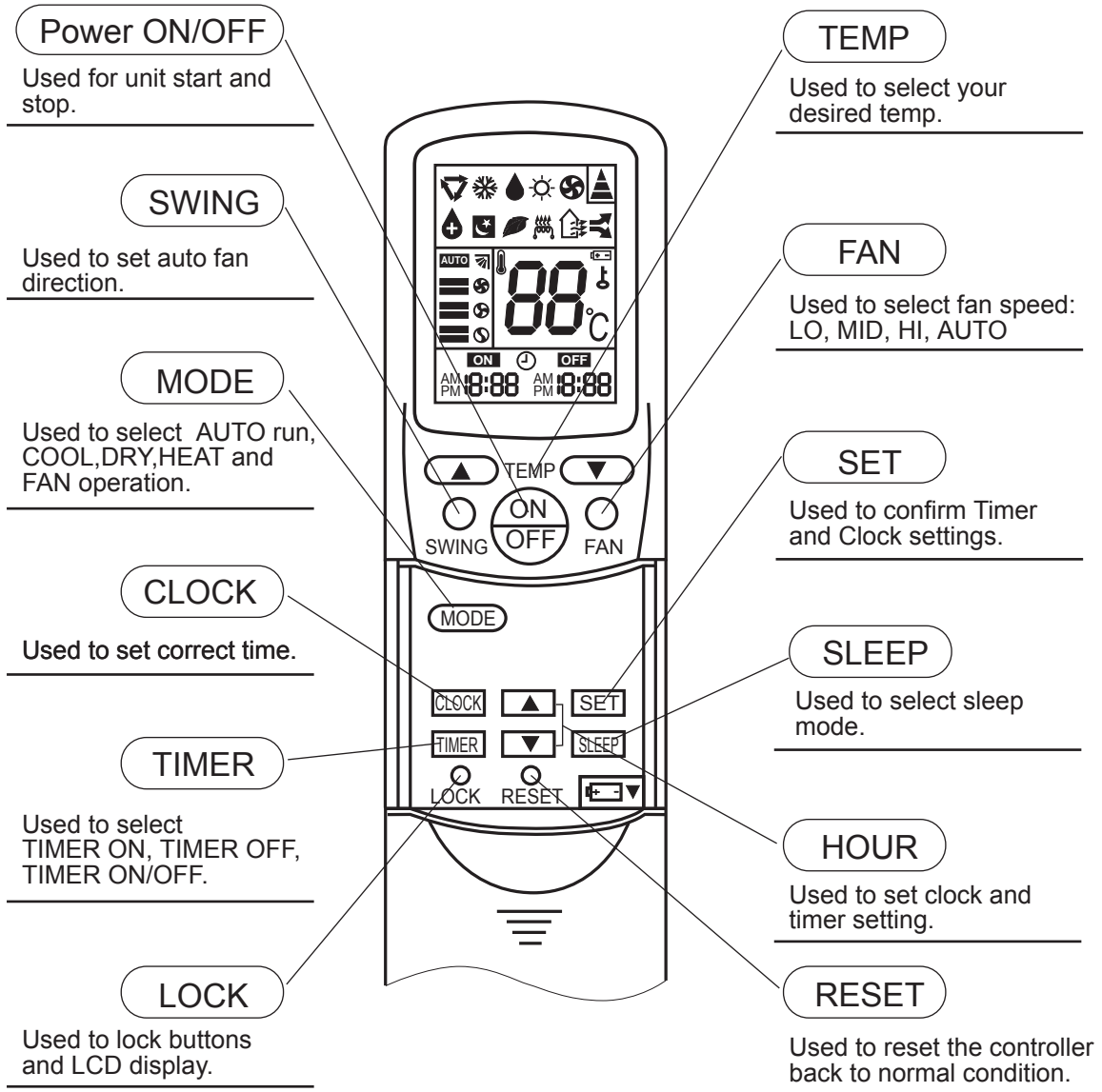

**Cautions:**

On cooling only unit, heating mode is not available.  
After replacing batteries, press ON/OFF, and display becomes as follows:  
Operation mode: AUTO, Temp: 24°C  
Timer mode: No, Fan speed: AUTO

**Note:**

1. The above information is the explanation of the displayed information therefore varies with those displayed in actual operation.
2. This type only has the relevant function and display as indicated in the above figure.

## INTRODUCTION TO SPARE PARTS

Buttons and display of the remote controller.

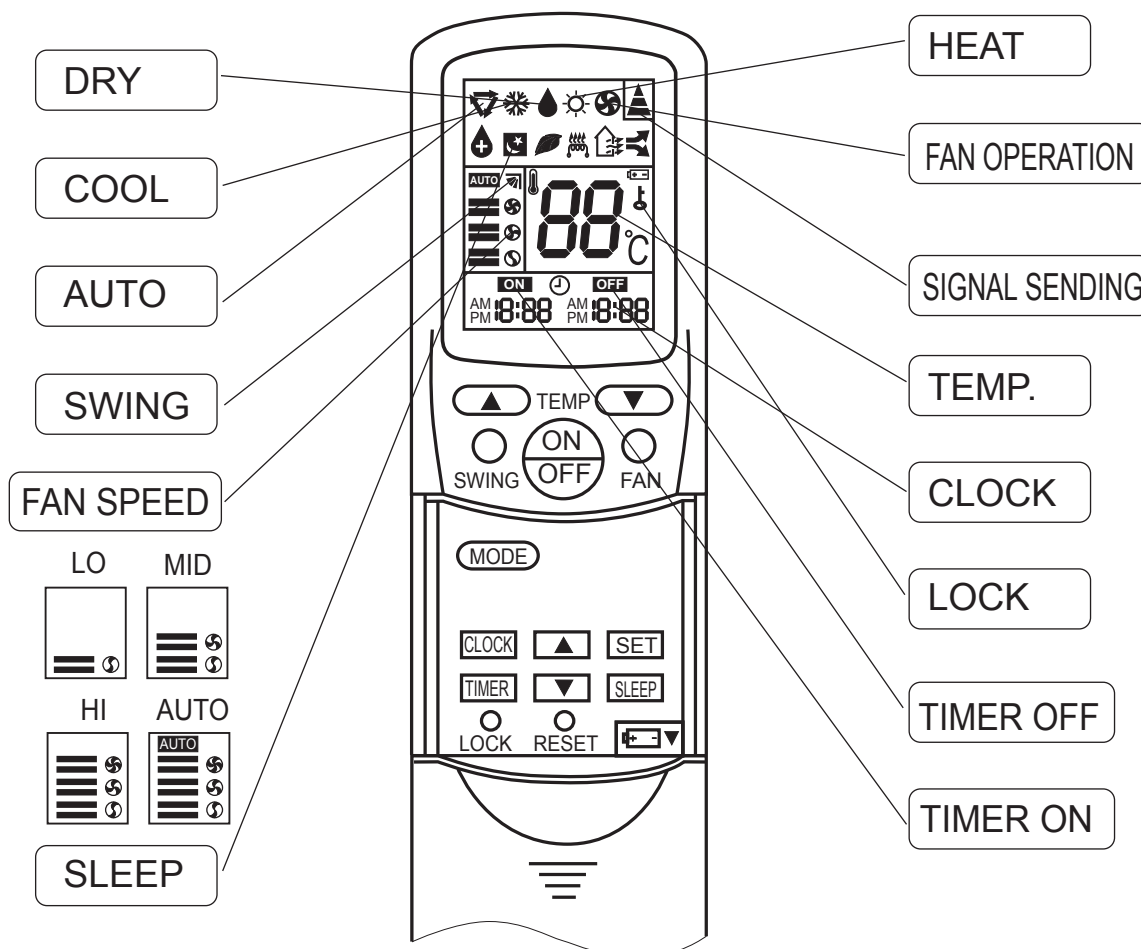

### Clock set

When unit is started for the first time and after replacing batteries in remote controller, clock should be adjusted as follows:

Press **CLOCK** button, "AM" or "PM" flashes.

Press **▲** or **▼** to set correct time. Each press will increase or decrease 1min. If the button is kept depressed, time will change quickly.

After time setting is confirmed, press **SET**, "AM" and "PM" stop flashing, while clock starts working.

### Hints

After replacing with new batteries, remote controller will conduct self-check, displaying all information on LCD. Then, it will become normal.

## REMOTE CONTROLLER OPERATION

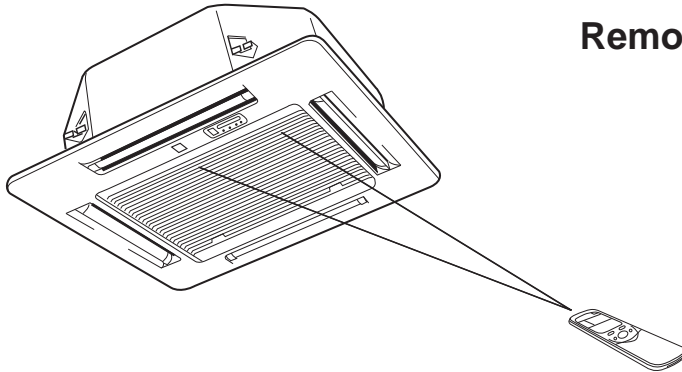

### Remote controller's operation

- When in use, put the signal transmission head directly to the receiver hole on the indoor unit.
- The distance between the signal transmission head and the receiver hole should be within 7m without any obstacle as well.
- Don't throw the controller, prevent it from being damaged.
- When electronic-started type fluorescent lamp or change-over type fluorescent lamp or wireless telephone is installed in the room, the receiver is apt to be disturbed in receiving the signals so the distance to the indoor unit should be shorter.

### Loading of the battery

Load the batteries as illustrated.  
2R-03 batteries, resetting key (cylinder)

### Remove the battery cover :

Slightly press "▼" and push down the cover.

### Load the battery :

Be sure that the loading is in line with the " + " / " - " pole request as illustrated.

### Put on the cover again

### Confirmation indicator :

In disorderation, reload the batteries or load the new batteries after 5mins.

### Note :

Use two new same-typed batteries when loading.  
If the remote controller can't run normally or doesn't work at all, use a sharp pointed item to press the reset key.

**Hint :** Remove the batteries in case unit won't be in usage for a long period.  
If there is any display after taking-out just need to press reset key.

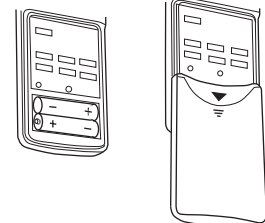
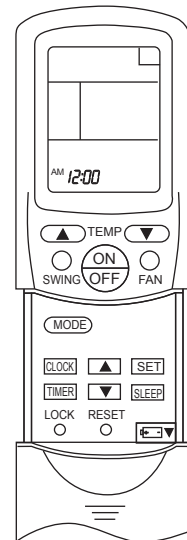

## GUIDE TO OPERATION

### FAN operation

#### (1) Unit start

Press ON/OFF button, unit starts.  
 Previous operation status appears on display.  
 (Not Timer setting)  
 Power indicator on indoor unit lights up.

#### (2) Select operation mode

Press MODE button. For each press, operation mode changes as follows:



Unit will run in selected mode.  
 stop display at " FAN " FAN.

#### (3) Fan

Press FAN button. For each press, fan speed changes as follows:

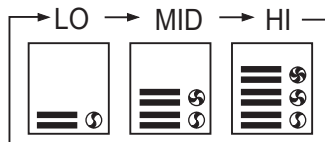

Unit will run at selected fan speed.  
 Adjust air flow direction if necessary, refer to page13.

#### (4) Unit stop

Press ON/OFF button.  
 Only time remains on LCD.  
 All indicators on indoor unit go out.  
 Vertical flap closed automatically.

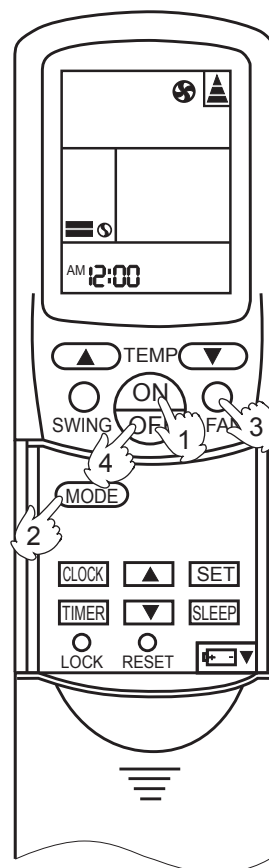

#### Hints

Remote controller can memorize settings in each operation mode. To run it next time just select the operation mode and it will start with the previous setting.  
 No reselecting is needed.(TIMER ON/OFF needs reselecting)

## GUIDE TO OPERATION

### AUTO run, COOL,HEAT and DRY operation

#### Recommendations

- Use COOL in summer.
- Use HEAT in winter.
- Use DRY in spring,autumn and in damp climate.

#### (1) Unit start

Press ON/OFF button, unit starts.

Previous operation status appears on display.(Not Timer setting)

Power indicator on indoor unit lights up.

#### (2) Select operation mode

Press MODE button. For each press, operation mode changes as follows:



Unit will run in operation mode displayed on LCD.

Stop display at your desired mode.

#### (3) Select temp.setting

Press TEMP button

▲ Every time the button is pressed, temp. setting increases 1°C

▼ Every time the button is pressed, temp. setting decreases 1°C

Unit will start running to reach the temp. setting on LCD.

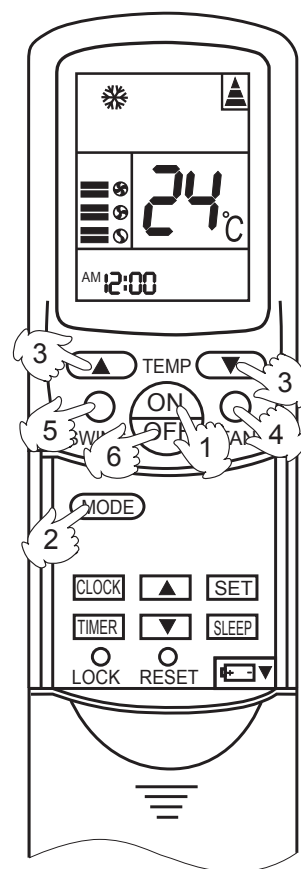

#### Hints

Remote controller can memorize each operation status. When starting it next time, just press ON/OFF button and unit will run in previous status.

## GUIDE TO OPERATION

### (4) Fan speed selection

Press FAN button. For each press, fan speed changes as follows:



Unit runs at the speed displayed on LCD.

In HEAT mode, warm air will blow out after a short period of time due to cold-draft prevention function.

In DRY mode, when room temp. becomes 2°C higher than temp. setting, unit will run intermittently at LO speed regardless of FAN setting.

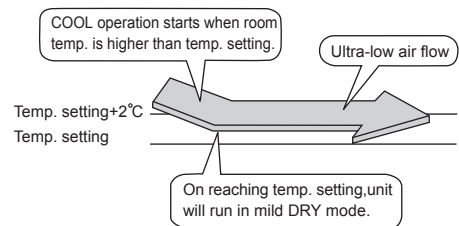

### (5) Air flow direction adjust

After operation mode is selected, vertical flap will open automatically according to the mode.

### (6) Unit stop

Press ON/OFF button.

Only time remains on LCD.

All indicators on indoor unit go out.

Vertical flap closes automatically.

#### Hints

As cold air flows downward in COOL mode, adjusting air flow horizontally will be much more helpful for a better air circulation.

As warm air flows upward in HEAT mode, adjusting air flow downward will be much more helpful for a better air circulation.

Be careful not to catch a cold when cold air blows downward.

It is harmful to your health in summer to go frequently in and out of places where temp. difference is above 7°C. Temp. difference of 3-5°C will remove your fatigue.

More than this, unit's load can be reduced and power consumption cut down as well. So, you'd better set a temp. diff of 3-5°C between indoor and outdoor temp. in COOL mode.

## GUIDE TO OPERATION

### TIMER operation

Set Clock correctly before starting Timer operation(refer to page 6)

You can let unit start or stop automatically at following times: Before you wake up in the morning, or get back from outside or after you fall asleep at night.

### TIMER ON/OFF

(1)After unit start, select your desired operation mode.

Operation mode will be displayed on LCD.

Power indicator on indoor unit lights up.

#### (2)TIMER mode selection

Press TIMER button to change TIMER mode.

Every time the button is pressed, display changes as follows:



Select your desired TIMER mode (TIMER ON or TIMER OFF) ON or OFF will flash.

#### (3)Timer setting

Press HOUR▲/▼ button.

▲Every time the button is pressed, time increases 10min.

If button is kept depressed, time will change quickly.

▼Every time the button is pressed, time decreases 10min.

If button is kept depressed, time will change quickly. Time will be shown on LCD. It can be adjusted within 24hours.

#### (4)Confirming your setting

After setting correct time, press SET button to confirm "ON" or "OFF" stops flashing

Time displayed: Unit starts or stops at x hour x min (TIMER ON or TIMER OFF).

Timer mode indicator on indoor unit lights up.

### To cancel TIMER mode

Just press TIMER button several times until TIMER mode disappears.

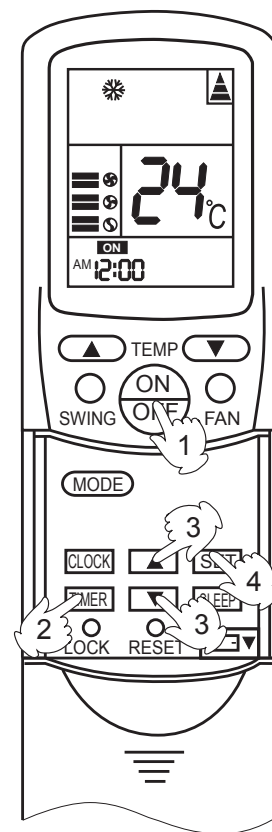

#### Hints

After replacing batteries or a power failure happens, Time setting should be reset. Remote controller possesses memory function, when use TIMER mode next time, just press SET button after mode selecting if timer setting is the same as previous one.

## GUIDE TO OPERATION

### TIMER ON-OFF

(1)After unit start, select your desired operation mode

Operation mode will be displayed on LCD.

Power indicator on indoor unit lights up.

(2)Press TIMER button to change TIMER mode

Every time the button is pressed, display changes as follows:



Select TIMER ON-OFF, "ON" will flash.

(3)Time setting for TIMER ON

Press HOUR button.

▲ Every time the button is pressed, time increases 10min.

If button is kept depressed, time will change quickly.

▼ Every time the button is pressed, time decreases 10min.

If button is kept depressed, time will change quickly. Time will be shown on LCD.

It can be adjusted within 24hours.

AM refers to morning and PM to afternoon.

(4)Time confirming for TIMER ON

After time setting, press TIMER button to confirm.

"ON" stops blinking, While "OFF" starts blinking.

Time displayed: Unit starts at X hour X min.

(5)Time confirming for TIMER OFF

Follow the same procedures in "Time setting for TIMER ON".

(6)Time setting for TIMER OFF

After time setting, press SET button to confirm "OFF" stops flashing.

Time displayed: Unit stops at X hour X min.

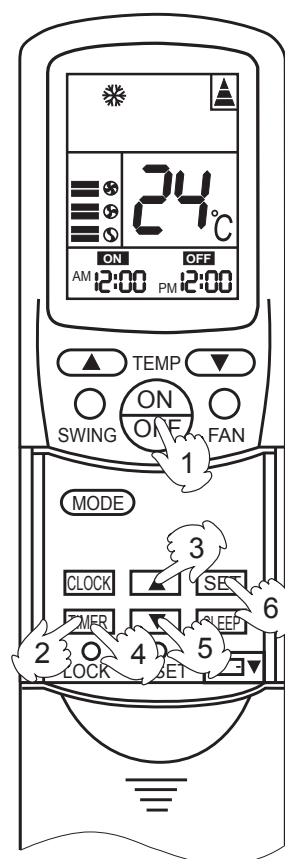

### To cancel TIMER mode

- Just press TIMER button several times until TIMER mode disappears.
- According to the Time setting sequence of TIMER ON or TIMER OFF, either Start-Stop or Stop-Start can be achieved.



### AIR FLOW DIRECTION ADJUSTMENT PROCEDURE

#### Adjusting up/down air flow direction

- Up/down direction can be adjusted by using the SWING button on the remote controller.

Each time pressing this button, the mode changes in the following sequence.

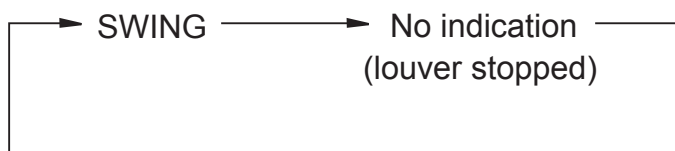

Change to the AIRFLOW mode.

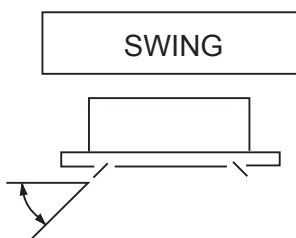

Louver moves in upward and downward directions continuously.



When the LOUVER button is pushed during SWING mode, it stops swinging at the just angle.

#### ⚠ CAUTION

- Avoid direct air flow to the body for many hours.
- Avoid downward blowing operation of cooling mode for many hours.
- Do not touch the swing louver during swing operation.

## Comfortable Sleep

At night, before going to bed you can press down the SLEEP button on the controller and the air-conditioner will run by the comfortable sleeping mode to make you sleep more comfortable.

Press SLEEP button once to make the air conditioner have the previous-set sleep time (first power-on is "1h"), the sleep symbol will appear. Press time button▲/▼, you can choose the time in 1~8 hours. Each press of▲/▼, the time increases/reduces 1 hour and "xh" appears in the humidity setting part, "OFF" appears in "TIMER OFF" display part and timer-off time; press SLEEP button again to cancel sleep function, the sleep symbol disappears.

## In cooling, dehumidifying mode

One hour after sleeping operation start, the temp. is 1°C higher than the setting one. After another hour the temp. rises 1°C and then run continuously for another 6hrs' and then close. The actual temp. is higher than the setting one which is to prevent from being too cool to your sleep.

## In heating mode

One hour after start up, the temp. decrease 2°C lower than the setting one. After another hour decrease by more 2°C.

The temperature will automatically rise by 1°C after another 3hrs' operation, and then automatically close after 3hrs' continuous operation. The actual temperature is lower than the setting one which is to prevent from being too hot to your sleep.

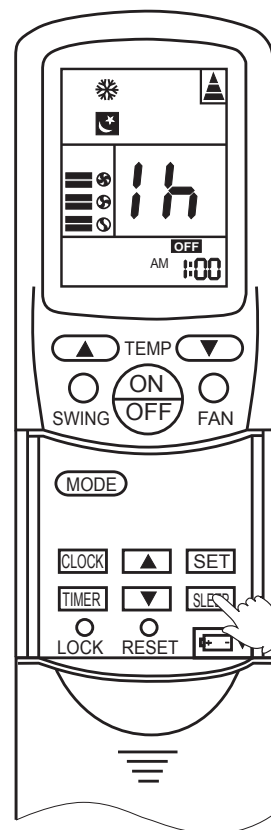

Note:

- In AUTO mode, unit will run in SLEEP function according to the operation mode.
- After setting SLEEP function, it is forbidden to calibrate clock.
- If the set sleep-time does not reach 8 hours, the unit will stop operation automatically after set time is complete.
- Set "TIMER-OFF" function first, then set SLEEP, and press the sleep-set-performance; set TIMER-ON function first, the sleep function can only be set before TIMER-ON; if set the SLEEP function first, the TIMER function can not be set.
- After setting SLEEP, press CLOCK button to show the time; press TEMP. button to show the temperature; press again to change temperature.
- When the set SLEEP time is 8 hours, connect it as shown in the following figure.

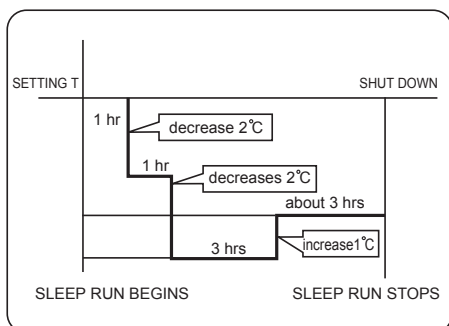

Heat mode

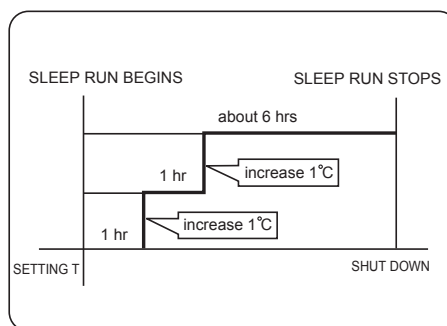

Cooling mode

### **Remote Control:**

There is a telecommunication interface for remote control on the control panel of the indoor unit. After the peripheral equipment have been installed in accordance with the instruction manual of the selected remote control detector, the air conditioner will be computerized and controlled from a far-away place.

### **Power Failure Resume (to be applied for a necessary situation):**

After the power failure compensation is set, if power failure suddenly occurs while the air conditioner is working, it will resume the previous working state when the power is supplied again.

**Setting Method:** When the remote controller is on (excluding timer mode and fan mode), press the "Sleeping" button on the remote controller 10 times within 5 seconds, and after the buzzer rings 4 times, the air conditioner will enter the state of power failure compensation.

**Cancel Method:** Press the "Sleeping" button on the remote controller 10 times within 5 seconds, and after the buzzer rings 2 times, the power failure compensation mode will be cancelled.

**Notes:** When a power failure suddenly occurs during the air conditioner is working after the power after the power failure compensation is set, if the air conditioner will not be used for a long time, please cut off the power supply to prevent its operation from being resumed after the power is supplied again, or press the "Switch On/Off" button after the power comes again.

## 7.2 Additional introduction to the remote controller for HBU-14 series

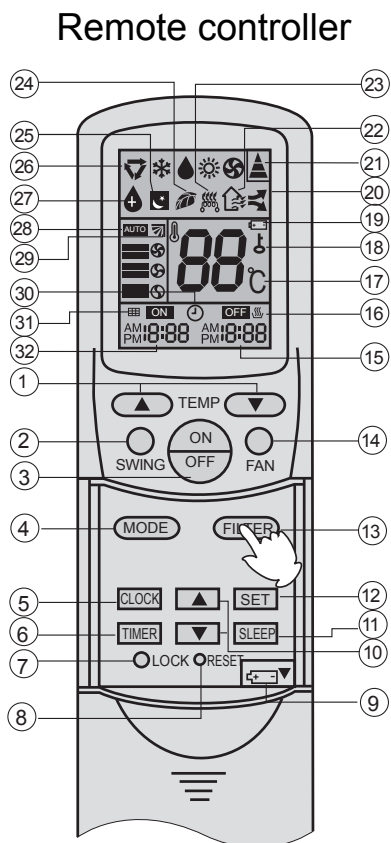

### 13. FILTER Button

Used to set up/down function of the filter.

After air conditioner operated for a period, dusts were gradually accumulated on the filter, and the filter up/down function can be used to clean the filter.

1. Whether unit start or stop, continuously press FILTER button 3 seconds, and enter into the filter up/down waiting status (when unit stops, the yellow TIMER indicator flashes, filter and clock displayed on the remote controller and no others. Only the FILTER button and the temperature button “▲” “▼” and time button “▲” “▼” are active).
2. Press temperature “▼” button or time “▼” button in filter up/down waiting status, the up/down mechanism makes the filter to move downward and do not stop until reach the maximum limit.
3. Press temperature “▲” button or time “▲” button in filter up/down waiting status, the up/down mechanism makes the filter to move upward till near to the surface board and then automatically adjust to reset (when adjusting to reset, it will not be controlled by the remote controller till the adjustment is finished, and the remote controller can control again).
4. During moving downward, press temperature “▲” button or time “▲” button, moving stops.
5. During moving downward, press temperature “▼” button or time “▼” button, moving stops.
6. Continuously press FILTER button 3 seconds again to cancel the filter up/down waiting mode (unit stops, the yellow timer indicator stops flashing, the filter backs to the original position, the remote controller backs to off status and only clock is displayed).

#### Note:

If the filter does not thoroughly back to the original position, only need to operate several times repeatedly.

# REMOTE CONTROLLER FUNCTIONS & REFRIGERANT DIAGRAM

## 7.3 Dimensions of the controller

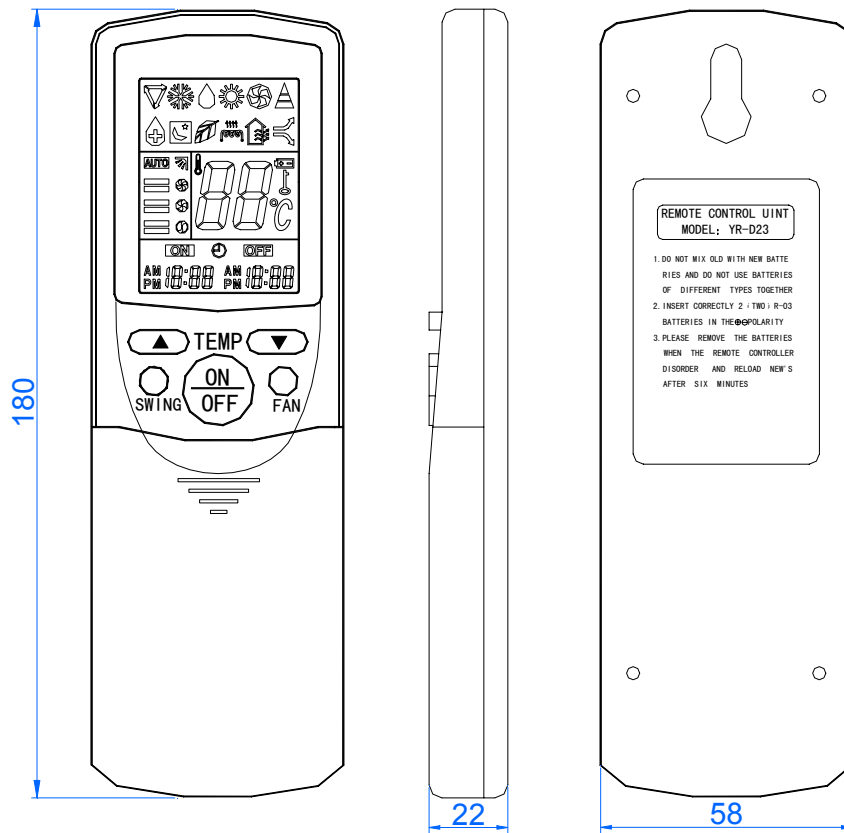

## 8 REFRIGERANT DIAGRAM

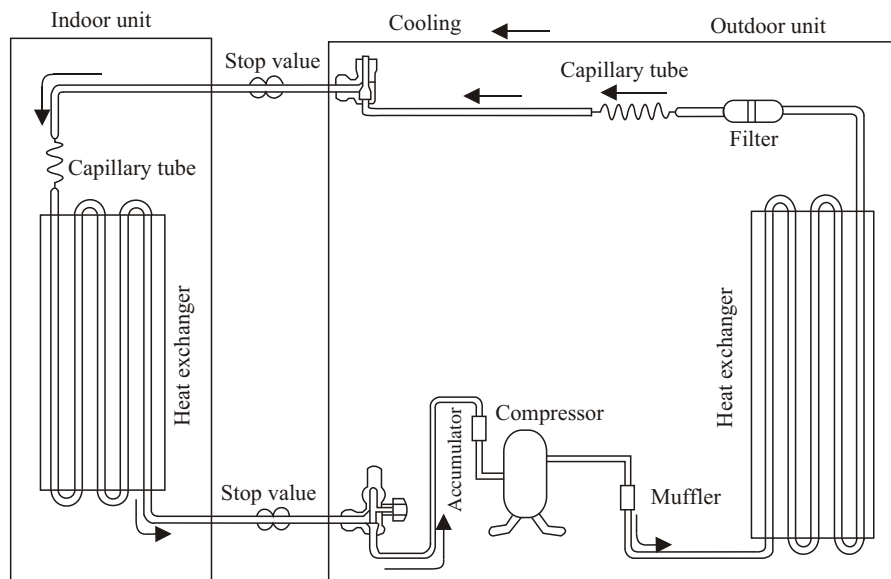

## 9 ELECTRICAL CONTROL FUNCTIONS

### 9.1 Control Features

The brief introduction includes those for each item of various types of air conditioners and their electric control functions.

#### 7.1 Brief introduction of electric control

##### (1) Automatic run

##### a. Cooling-heating type

After the machine being started and running mode changes to AUTO, the system will decide running mode according to difference between the present room temperature and setting temperature, then runs as the decided mode. In the following selections,  $T_r$  means room temperature and  $T_s$  means setting temperature.

Select running mode according to the following conditions at the first time to enter Auto mode:

- $T_r \geq T_s - 3^\circ\text{C}$  to select cooling mode (with setting temperature being  $T_s + 3$ )
- $T_r < T_s - 3^\circ\text{C}$  to select heating mode (with setting temperature being  $T_s$ )

After the system entering auto run mode, the running mode can convert automatically according to variation of room temperature between cooling, blowing and heating in the way shown as the chart below:

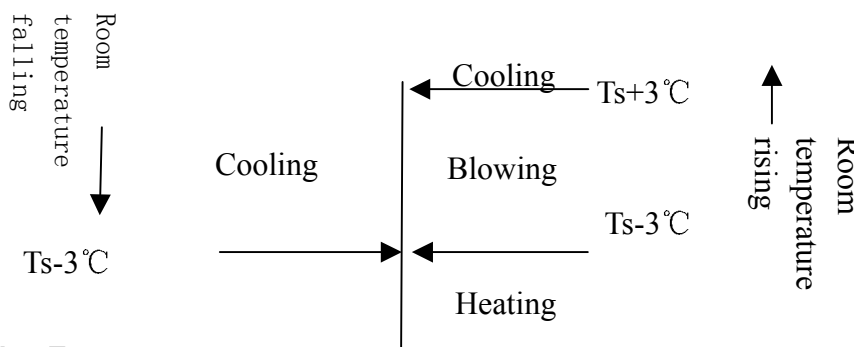

##### b. Single Cooling Type

Select running mode according to the following conditions at the first time to enter Auto mode:

- $T_r \geq T_s + 3^\circ\text{C}$  to select cooling mode
- $T_r < T_s + 3^\circ\text{C}$  to select blowing mode

After the system entering auto run, the running mode can convert automatically according to variation of room temperature between cooling and blowing functions in the way shown as the chart below:

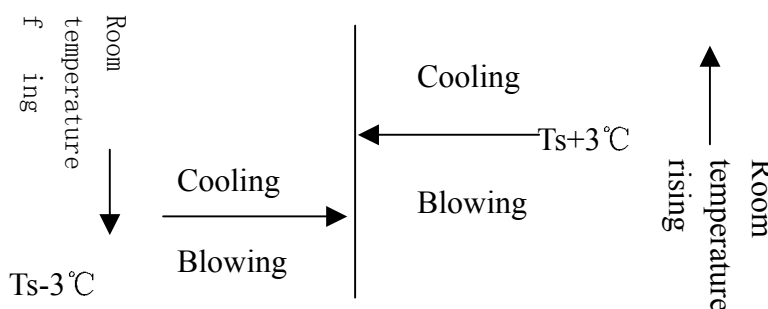

(2) Auto Selection of Wind Speed

In the following,  $T_r$  means room temperature while  $T_s$  means setting temperature.

**a. During cooling program**, conversion of wind speed from the low to high won't work until the present speed has continued for 3 minutes while conversion from the high to low needs no time delay. The chart below is the sketch map of conversion:

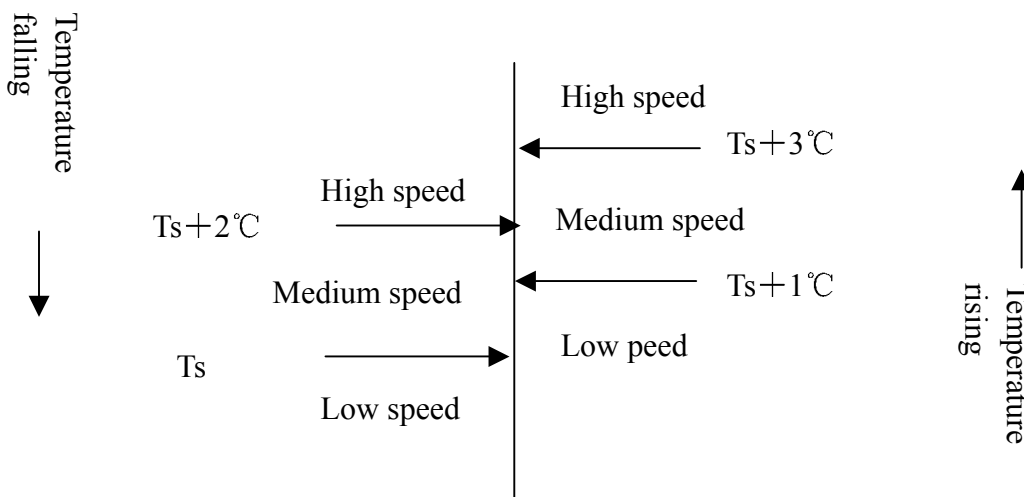

**b. During heating program** (applicable for cooling-heating type), conversion of wind speed from the low to high won't work until the present speed has continued for 3 minutes while conversion from the high to low needs no time delay. The chart below is the sketch map of conversion:

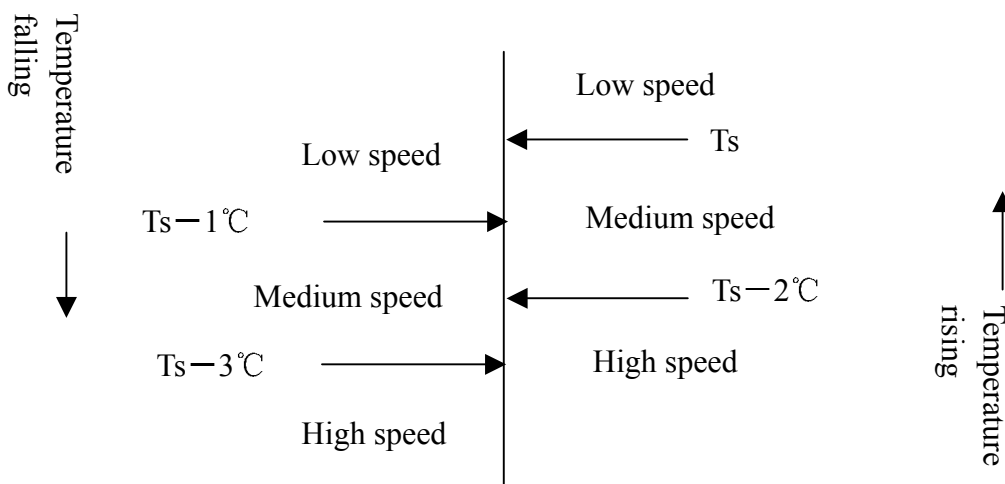

(3) Dehumidifying program

In the following,  $T_r$  means room temperature while  $T_s$  means setting temperature.

a. After the system entering dehumidifying program, the compressor, outdoor and indoor blowing fans run according to the following rules:

(1)  $T_r > T_s + 2^\circ\text{C}$ , the compressor and outdoor blowing fan run continuously while indoor

blowing fan runs at setting wind speed. This working area is defined as area A.

- (2)  $T_s \leq T_r \leq T_s + 2^\circ\text{C}$ , the compressor and outdoor blowing fan run for 10 minutes then pause for 6 minutes, while indoor blowing fan runs at low wind speed. This working area is defined as area B.
- (3)  $T_r < T_s$ , the compressor and outdoor blowing fan stop working while outdoor blowing fan runs at low wind speed. This working area is defined as area C.

a. After dehumidifying program starting, the system converts between A, B and C areas according to variations of room temperature with running mode being shown as the chart below:

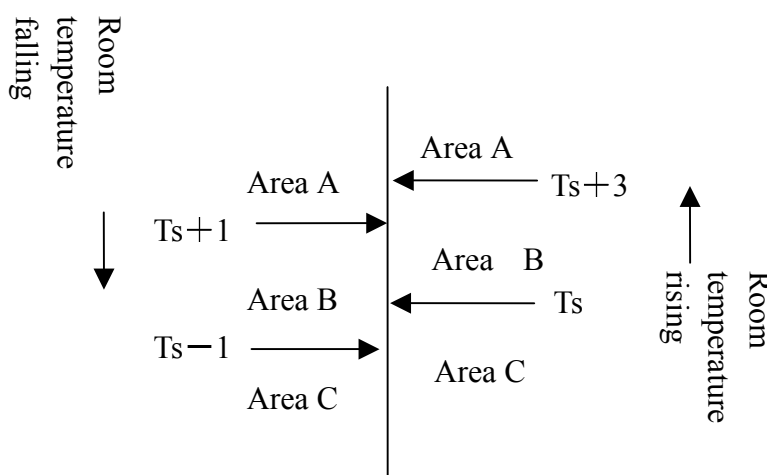

#### (4) Cutoff protection against overload and overheat

During heating program, if the indoor blowing fan has been started and the compressor has been running more than 2 minutes, and the **temperature of indoor coil pipe (Ticp)**  $> 64^\circ\text{C}$ , the outdoor blowing fan will stop running; If  $Ticp \leq 50^\circ\text{C}$  and the outdoor blowing fan has kept stop state for 45 seconds, then it will restore rotation; If  $Ticp > 67^\circ\text{C}$  and such temperature has last for 10 seconds, the compressor will stop running and indoor blowing fan run according to conditions as it reaches setting temperature. When  $Ticp < 58^\circ\text{C}$ , and the compressor has kept stop state over 3 minutes, then the compressor and outdoor blowing fan will restore normal running.

#### Cutoff protection for heating current

After 60 seconds from the compressor being started, if CT current exceeds I1 (9.2A) and such case has kept 5 seconds, the outdoor blowing fan will stop. If 45 seconds has passed after the outdoor blowing stops and the current of the compressor is less than I2 (7.5A), the blowing fan will restore running. If CT current exceeds I3 (14.3A) and such case lasts for 3 seconds, the compressor and outdoor blowing fan will stop. The compressor will not restore running until 3 minutes passes with CT current less than 12A.

#### (5) Cool wind prevention during heating program

At the first time entering heating program or after ending the latest frost removal, if the **temperature of indoor coil pipe (Ticp)**  $< 28^\circ\text{C}$ , the indoor blowing fan will stop running; If  $28^\circ\text{C} \leq Ticp < 38^\circ\text{C}$ , the indoor blowing fan will run at low speed; If  $Ticp > 38^\circ\text{C}$  or the compressor has been running for more than 4 minutes, the indoor blowing fan will run at



setting wind speed.

(6) Afterheat blowing during heating program

During heating program, the compressor will stop running (except overheat protection or frost removal) while the indoor blowing fan will firstly run for 50 seconds at low speed then stop.

(7) Frost removal control (applicable for cooling-heating type)

(1) Starting conditions for frost removal:

- A. The indoor unit is in overload protection and outdoor blowing fan stops. The outdoor blowing fan does not enter overheat mode in 10 minutes after it is restarted, the compressor has run over 45 minutes totally while 20 minutes continuously, and the temperature of indoor coil pipe is lower than 43°C;
- B. After the compressor continuously running for 20 minutes, the temperature of indoor coil pipe falls 1°C every 6 minutes and such case continuously appears three times, and the temperature of indoor coil pipe is less than 40°C, and 5 minutes have passed after the compressor is restarted;
- C. The compressor has run totally over 3 hours while 20 minutes continuously, and the temperature of indoor coil pipe is less than 40°C;
- D. The difference between room temperature and the one of indoor coil pipe is less than 16°C and the compressor has totally run over 45 minutes while 20 minutes continuously;

Frost removal will start if any one of the above conditions is satisfied.

(2) Ending conditions for frost removal:

- 1) Time of frost removal has exceeded 9 minutes;
- 2) CT current exceeds I<sub>4</sub>(8.2A);

(3) Actions of each load after the frost removal starts:

The compressor and outdoor blowing fan stop, and indoor blowing fan also stops. 55 seconds later the reversal valve is closed and next 5 seconds later the compressor is started.

(4) Actions of each load after the frost removal ends:

The compressor stops running while outdoor blowing fan immediately runs at high speed, 55 seconds later the reversal valve is opened and next 5 seconds later the compressor restores running and indoor blowing fan runs as conditions for cool wind prevention.

(8) Freeze protection

After the compressor has run for 9 minutes, the system will check **temperature of indoor coil pipe (Ticp)**. If Ticp is less than -1°C, the compressor and outdoor blowing fan will stop. They will run again after the compressor stops if both the following conditions are satisfied:

- 1) 3 minutes have passed since compressor stops.
- 2) Ticp exceeds 7°C.

(9) 3 minutes protection for compressor

After compressor stops, it cannot be started until 3 minutes later. During the machine's running, if time after losing power not exceeds 3 minutes, the compressor cannot be

restarted until 3 minutes later after it is reenergized.

### (10) Power breakdown memory

If the machine suddenly loses power while running, or stops for maintenance or trouble shooting, it will restart running as the status when it stops after the power is restored.

Note: 1. Function setting: Continuously press sleep button on the remote controller 10 times in 5 seconds and buzzer on control panel shall beep 4 times.

2. Memory content: Running mode, wind speed setting, temperature setting, swing status.

3. Cancel: Press sleep button on the remote controller 10 times and buzzer on control panel beeps 2 times.

### (11) Control of water pump

a. In cooling (including automatic cooling mode) and dehumidifying modes, the water pump works if the compressor runs while stops 5 minutes later after the compressor stops.

b. When water tank is fully filled, the float switch will be off. The water pump will start to work after a controller has detected this signal and it will continue working for 5 minutes after the float restores to normal state.

c. If the full water signal is detected continuously over 5 minutes, the water pump indicator lamp will flash to alarm and compressor stops running. The water pump will run 5 minutes, then pause for 5 seconds before next 5 minutes' running, ... until the float restores to normal state, after which the pump will run for 5 minutes then stop.

### (12) Monitoring of remote network

Through preset interface, the air conditioner is connected to remote control detector (made by Haier) with 2-core cables for wire communication, to execute instructions sent from computer or centralized controller via remote control detector and meanwhile send present running status and trouble information of the machine to remote control detector.

Connection between air conditioner and remote control detector:

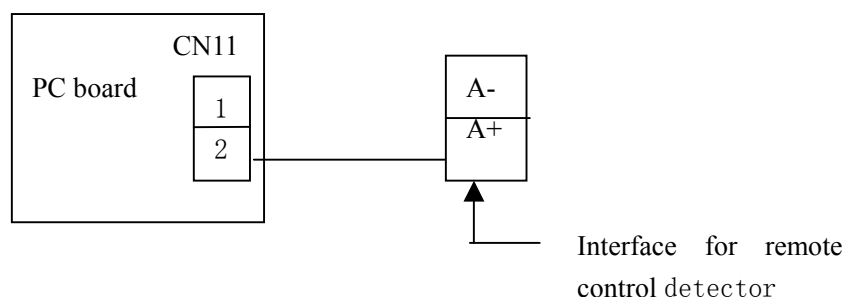

### (13) Trial run

Under shut-down state, hold pressing mandatory button. The buzzer will beep once, then twice after 5 seconds. Release the button to enter mandatory cooling mode, under which the indoor blowing fan runs at high speed with both the compressor and outdoor blowing fan working. Press the mandatory button again can end the mandatory mode.

9.2 Defrost operation flow chart

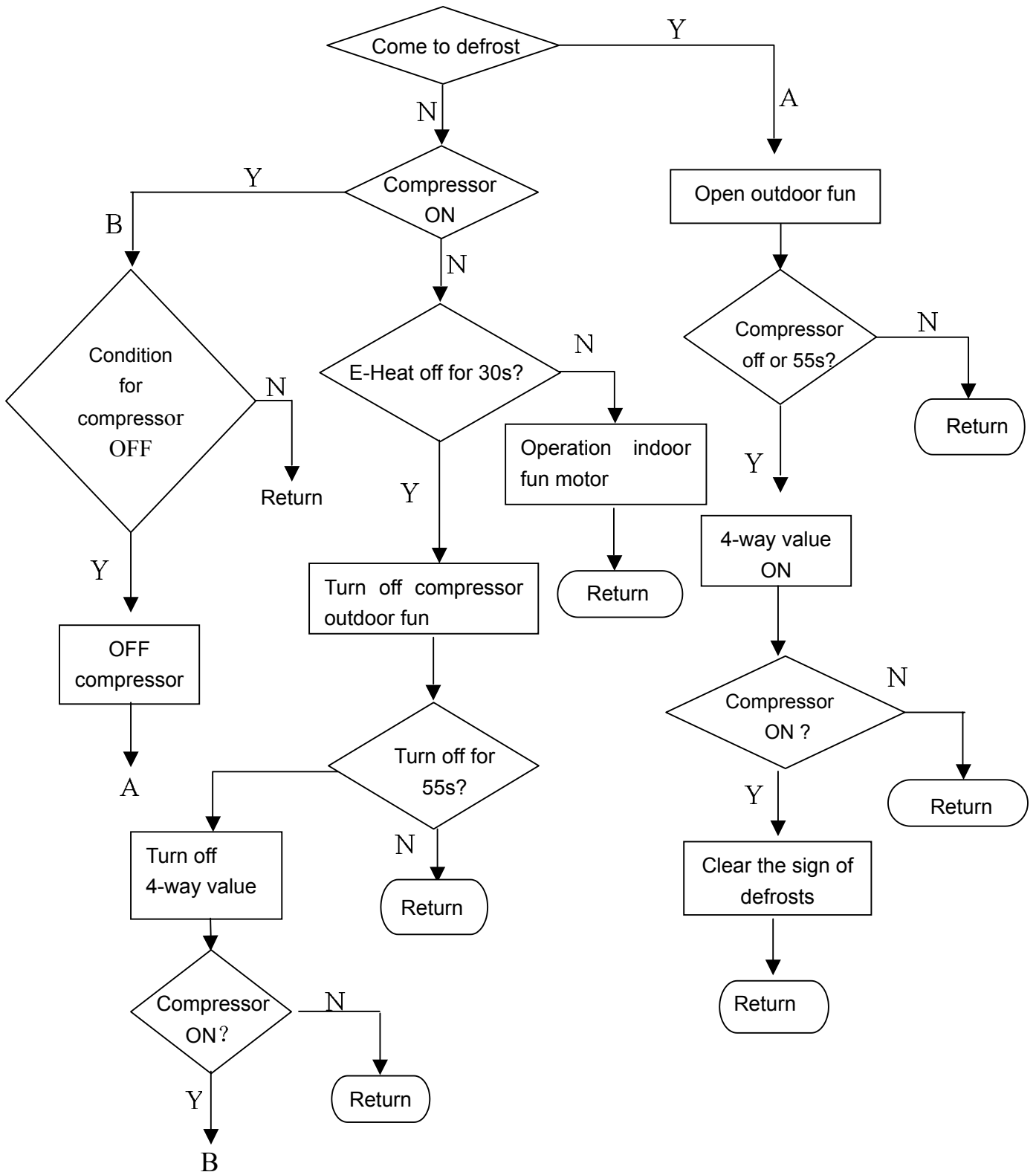

## **10 DIAGNOSTIC INFORMATION (TROUBLE SHOOTING)**

### **10.1 Fault codes**

No.	Code	Flash time of compressor running indicate lamp	Trouble contents (new)
1	E0	10	drainage system trouble
2	E1	1	indoor temperature sensor broken
3	E2	2	indoor coil temperature sensor broken
4	E3	3	outdoor temperature sensor broken
5	E4	4	outdoor coil temperature sensor broken
6	E5	5	over current protect limit
7	E6	6	pressure protect
8	E7	7	three phase protect
9	E8	8	Communication trouble between wired remote controller and indoor unit
10	E9	9	communication trouble between indoor and outdoor unit

Indicate lamp of remote control receiver board:

Green----power lamp

Yellow----timer lamp

Red----running of compressor (flashes to show the trouble)

Red----water pump

The faults are shown by lamp flashing or display on the remote controller

The code "Exx" only shows on the wired remote controller of the wired controlled unit.

**10.2 Trouble shooting - Detailed for engineer**

<b>Trouble</b>	<b>Checkup result</b>	<b>Possible reasons</b>	<b>Corresponding solution</b>
No response after power being connected	Unavailable voltage at input part of circuit board	The power supply coil isn't plugged well	Plug the supply coil properly
	Unavailable voltage at one end of the fuse	Damaged wave filtering component	Return to the controller manufacturer for repair
	Unavailable output from the consequent pole of transformer	Damaged fuse	Replace with a good one
	Improper output of 7805	The transformer isn't plugged well or is damaged	Plug the transformer well or replace with a good one
	Normal power supply for major chip	Damaged component on power supply unit of indoor board	Return to the controller manufacturer for repair
Display board does not make normal response	Indicator lamps do not light	Damaged major chip	Return to the controller manufacturer for repair
		Damaged connection cable between display board and indoor board	Replace with a good connection cable
	Remote control cannot be received	Connection cable between display board and indoor board isn't connected well	Connect the cable well
		Damaged reception adaptor	Replace with a good one
		Damaged remote circuit or major chip	Return to the controller manufacturer for repair
The buzzer does not beep while making remote control	Unavailable square wave signal at two ends of the buzzer	Damaged dynatron Q1	Replace with a good one
		Damaged major chip	Return to the controller manufacturer for repair
	Available square signal at two ends of the buzzer	Damaged buzzer	Replace with a good one
		No output from 2803 on indoor board	Replace with a good 2803
		Normal output of relays K1, JK2, JK3	Connect connection parts well
Indoor blowing fan does not run	No output at 16 pin of 2803 on indoor board	Replace with a good 2803	
	Unavailable voltage on COM port of relay JK2 on indoor board	Replace with a good one	
	No output at relay JK1 on indoor board	Replace with a good one	

## DIAGNOSTIC INFORMATION (TROUBLE SHOOTING)

Trouble	Checkup result	Possible reasons	Corresponding solution
Indoor blowing fan cannot generate medium wind	No output at 15 pin of 2803	Damaged 2803	Replace with a good 2803
	No voltage at COM of relay JK3 on indoor board	Damaged relay JK3	Replace with a good JK3e
Indoor blowing fan cannot generate high wind	No output at relay JK2 on indoor board	Damaged relay JK2	Replace with a good JK2
	No output at 14 pin of 2803	Damaged 2803	Replace with a good 2803
No output of swing	No output at relay JK3 on indoor board	Damaged relay JK3	Replace with a good JK3
	No output at 11 pin of 2803	Damaged 2803	Replace with a good 2803
Unavailable power breakdown memory	No output at relay JK6 of indoor board	Damaged relay JK6	Replace with a good JK6
		No setting has been made	Press sleep button 10 times within 5 seconds (and the buzzer will beep 4 times), the system is then set to power breakdown memory mode.
Unavailable power breakdown memory		Damaged chip IC6 of indoor board	Return to the controller manufacturer for repair
		Damaged 2803	Replace with a good 2803
No output of four-way valve during heating program	No output at 18 pin of 2803	Damaged 2803	Replace with a good 2803
	No output of relay JK7 on indoor board	Damaged relay JK7	Replace with a good JK7
No swing wind under swing mode	Available output of relay JK7 on indoor board	Socket CN6 is not plugged well with connection cable	Plug CN6 and the connection cable well
	No output at 12 pin of 2803	Damaged 2803	Replace with a good 2803
No swing wind under swing mode	No output of relay JK5 on indoor board	Damaged relay JK5 on indoor board	Replace with a good JK5
	Available output of relay JK5 on indoor board	Socket CN4 is not plugged well with connection cable	Plug CN4 well with the connection cable

## DIAGNOSTIC INFORMATION (TROUBLE SHOOTING)

Trouble	Checkup result	Possible reasons	Corresponding solution
During cooling program, the compressor does not start when the temperature meets proper conditions		Three minutes' protection for compressor	The compressor will work normal after three minutes
		Too low temperature of indoor coil pipe causes overcooling protection	It will restore automatically when the temperature of indoor coil pipe rises to 7°C
	No output at 11 pin of 2803 on indoor board	Damaged 2803	Replace with a good 2803
During heating program, the compressor does not start when the temperature meet proper conditions	No output of relay JK6 on indoor board	Damaged relay JK6 on indoor board	Replace with a good JK6
	No output of relay JK6 on indoor board	Connection cable between the compressor and JK6 isn't plugged well	Plug the connection cable well
		3 minutes' delay protection for compressor	It will restore normally after 3
During heating program, the compressor does not start when the temperature meet proper conditions		Too high temperature of indoor coil pipe causes overheat protection	It will automatically restore when the temperature of indoor coil pipe falls to 57°C
	No output at 11 pin of 2803 of indoor board	Damaged 2803	Replace with a good 2803
	No output of relay JK6 on indoor board	Damaged relay JK6 on indoor board	Replace with a good JK6
During heating program, the compressor does not start when the temperature meet proper conditions	Available output of relay JK6 on indoor board	Connection cable between compressor and JK6 isn't plugged well	Plug the connection cable well
	No output at collector of Q2 on indoor board	Damaged Q2	Replace with a good Q2
	No output of relay JK8 on indoor board	Damaged relay JK8 on indoor board	Replace with a good JK8
During cooling program, the compressor works while outdoor blowing fan does not	Available output of relays on indoor board	Socket CN6 is not plugged well with connection cable	Plug the connection cable well

## DIAGNOSTIC INFORMATION (TROUBLE SHOOTING)

Trouble	Checkup result	Possible reasons	Corresponding solution
During heating program, the compressor work while outdoor blowing fan does not		Too high temperature of indoor coil pipe causes overheat protection	It will automatically restore when the temperature of indoor coil pipe falls to 57°C
	No output at collector of Q2 on indoor board	Damaged Q2	Replace with a good Q2
During heating program, the compressor work while outdoor blowing fan does not	No output of relay JK8 on indoor board	Damaged relay JK8 on indoor board	Replace with a good JK8
	Available output of relays on indoor board	Socket CN6 is not plugged well with connection cable	Plug the connection cable well
Abnormal overcurrent detection	Current transformer outputs normally	Damaged rectification diode D6-D7 etc.	Return to the controller manufacturer for repair
	Transformer CT1 outputs abnormally	Damaged transformer CT1	Replace with a good one
	Inaccurate protection current	Adjust the adjustable potentiometer	
With timing indicator and compressor indicator extinguishing, the operation indicator flashes every second		Damaged major chip	Return to the controller manufacturer for repair
		Damaged indoor temperature sensor	Replace with a good one
With timing indicator and compressor indicator lighting, the operation indicator flashes every second		Damaged temperature sensor for indoor coil pipe	Replace with a good one
	No output at 13 pin of 2803 on indoor board	Damaged 2803	Replace with a good 2803
Water pump indicator flashes every second (trouble for water discharging)	No output of relay JK6 on indoor board	Damaged relay JK4 on indoor board	Replace with a good JK4
	Available output of relay JK6 on indoor board	Socket CN5 is not plugged well with connection cable	Plug the connection cable well
		Faulty connection cable to transmit float feedback signal	Replace with a good one



# 11 ELECTRICAL DATA

## 11.1 Wiring Diagram HBU-14H03

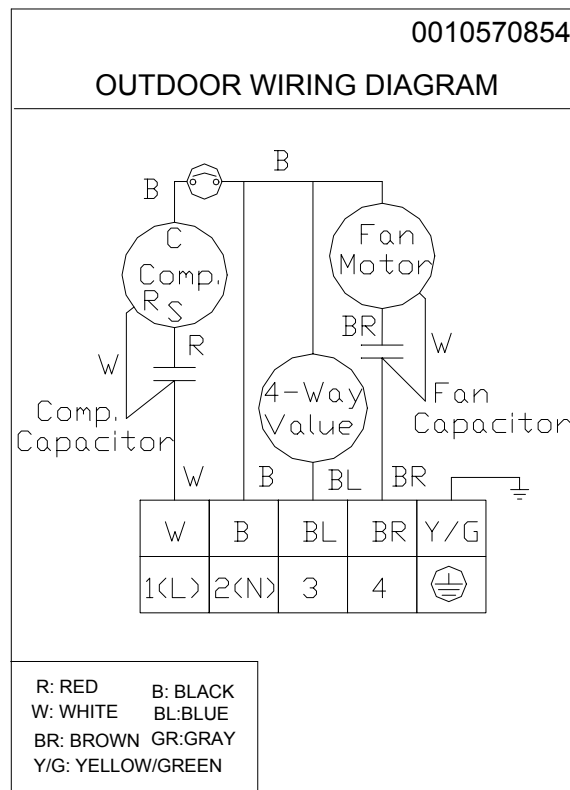
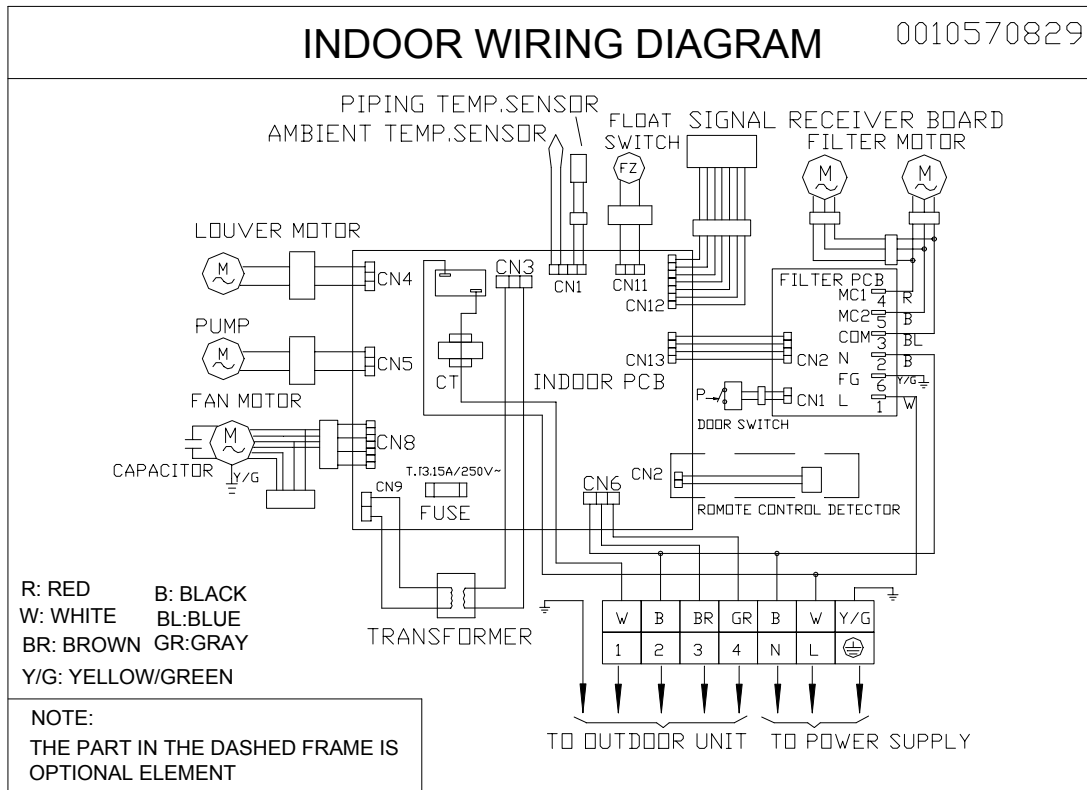

HBU-18HC03

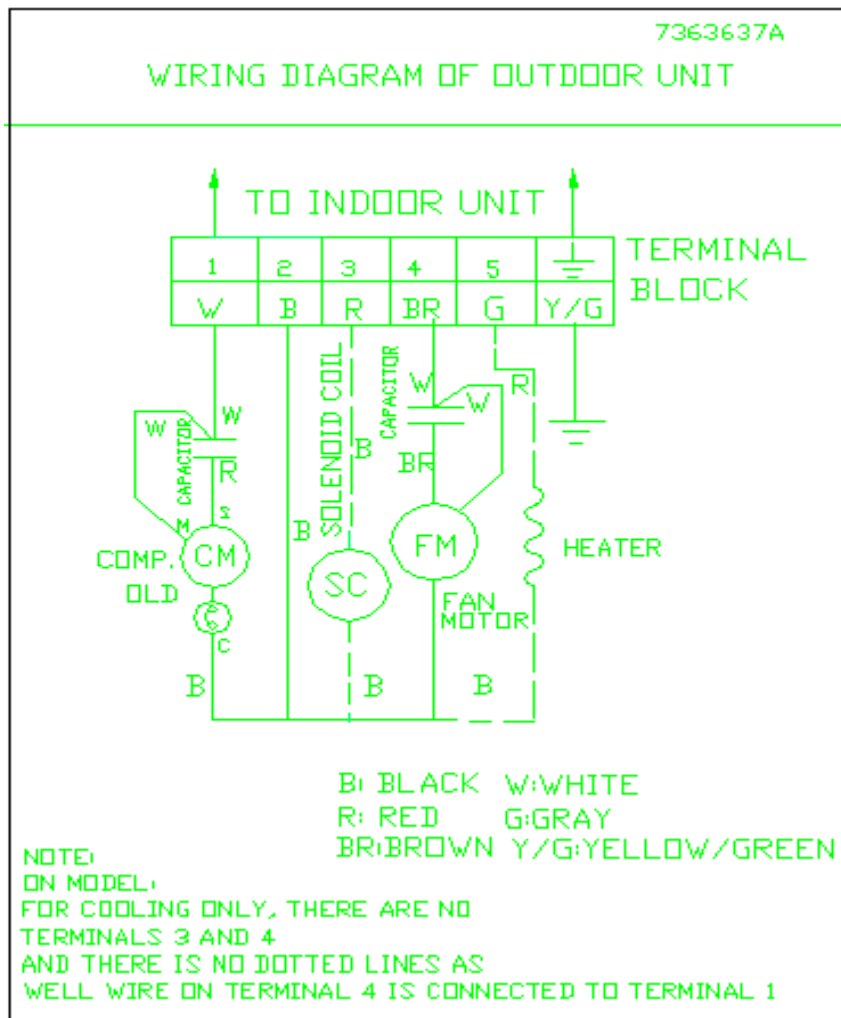
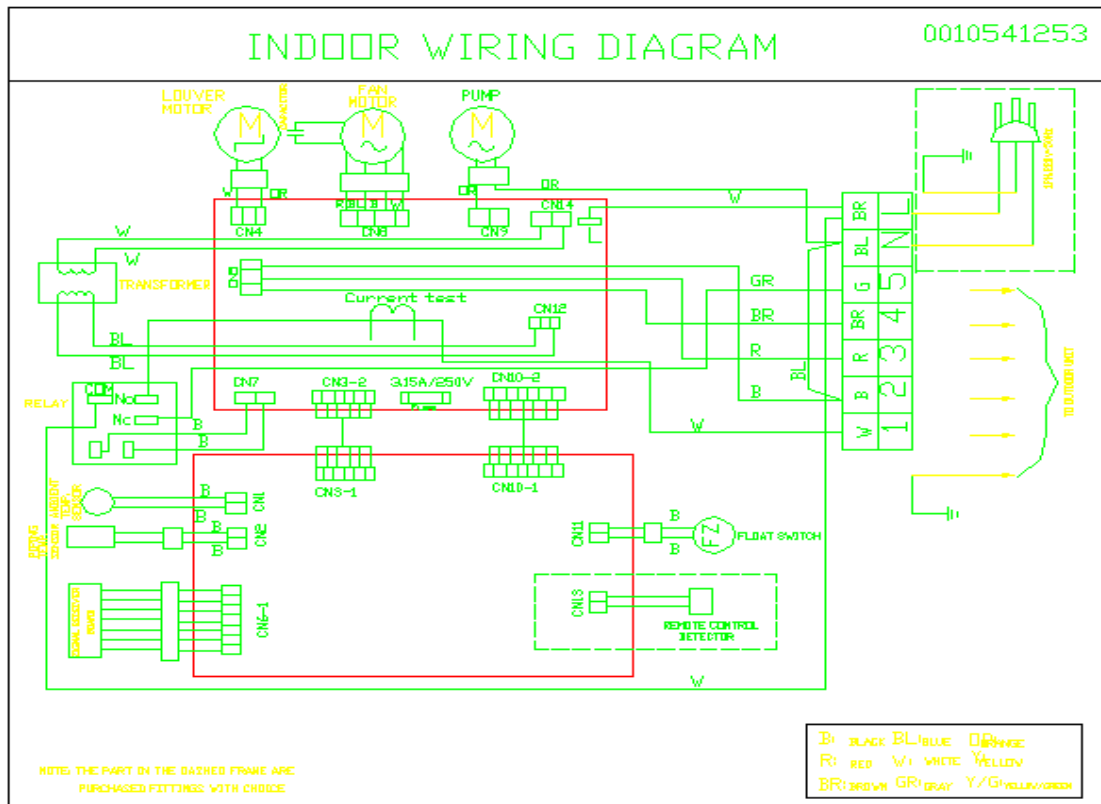

HBU-24H03

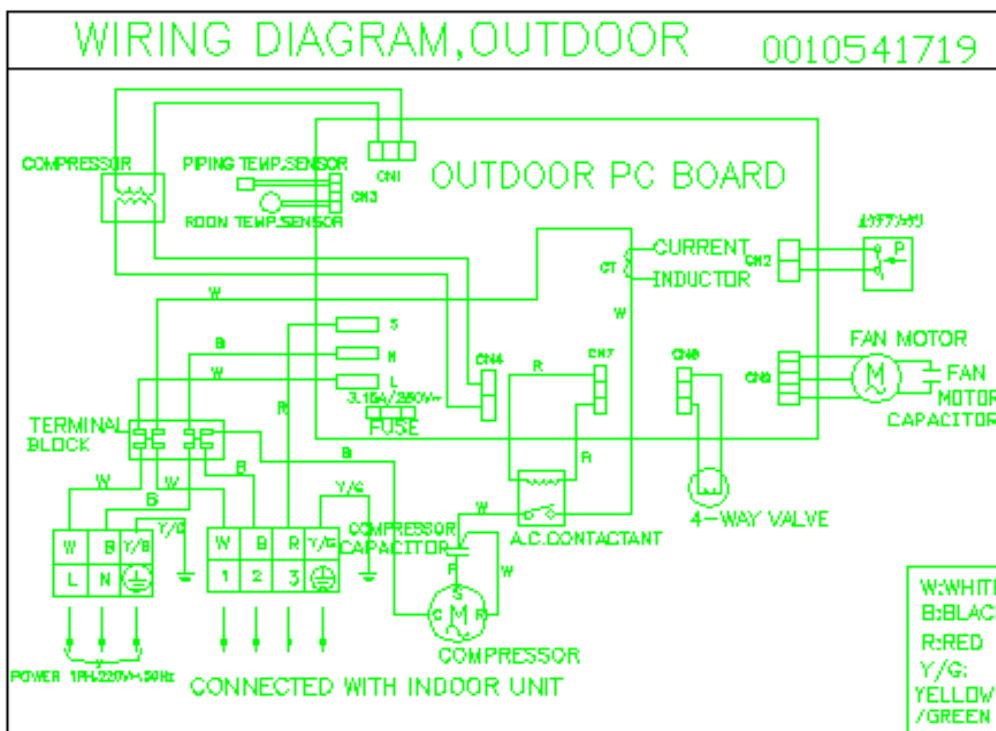
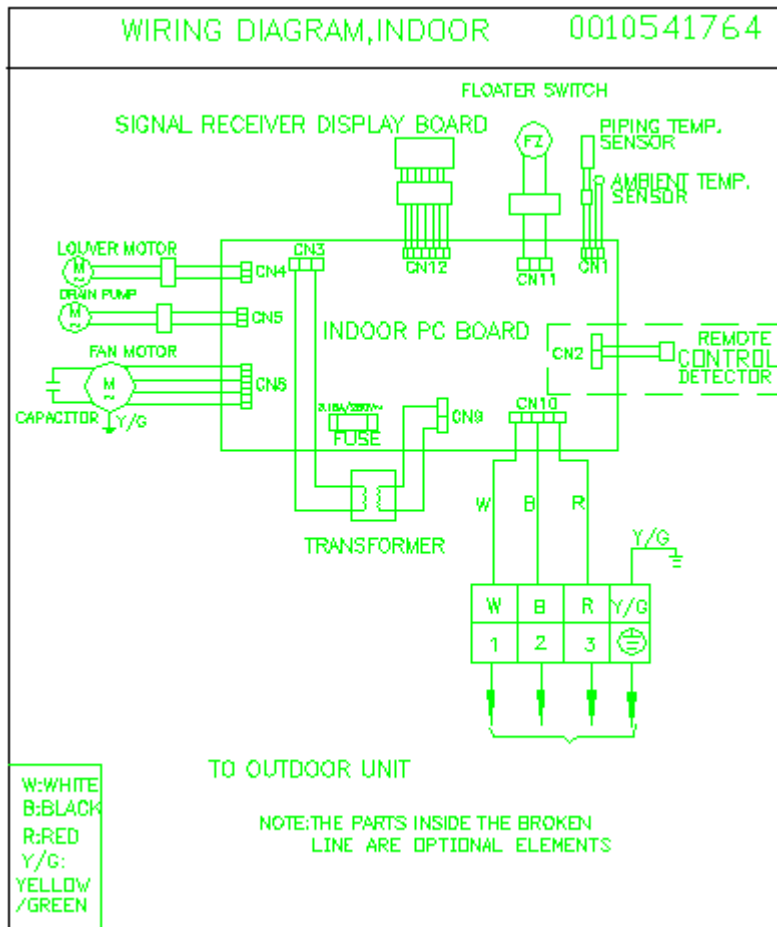

HBU-36H03 HBU-42HD03

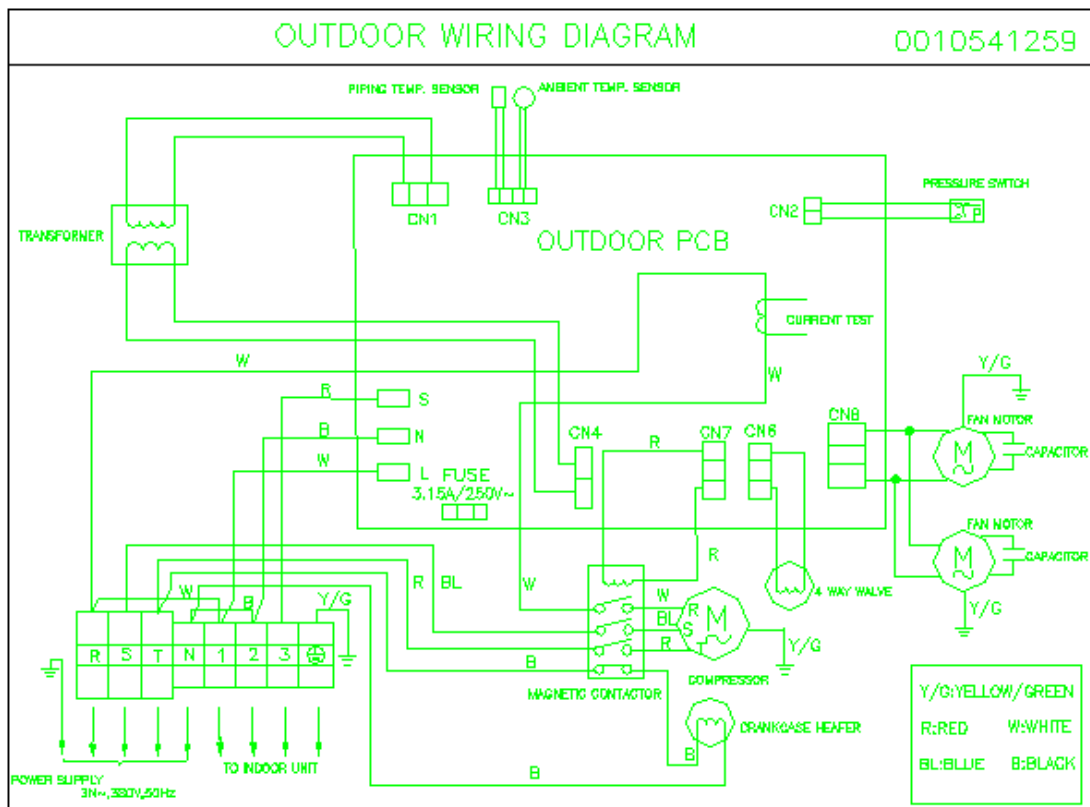
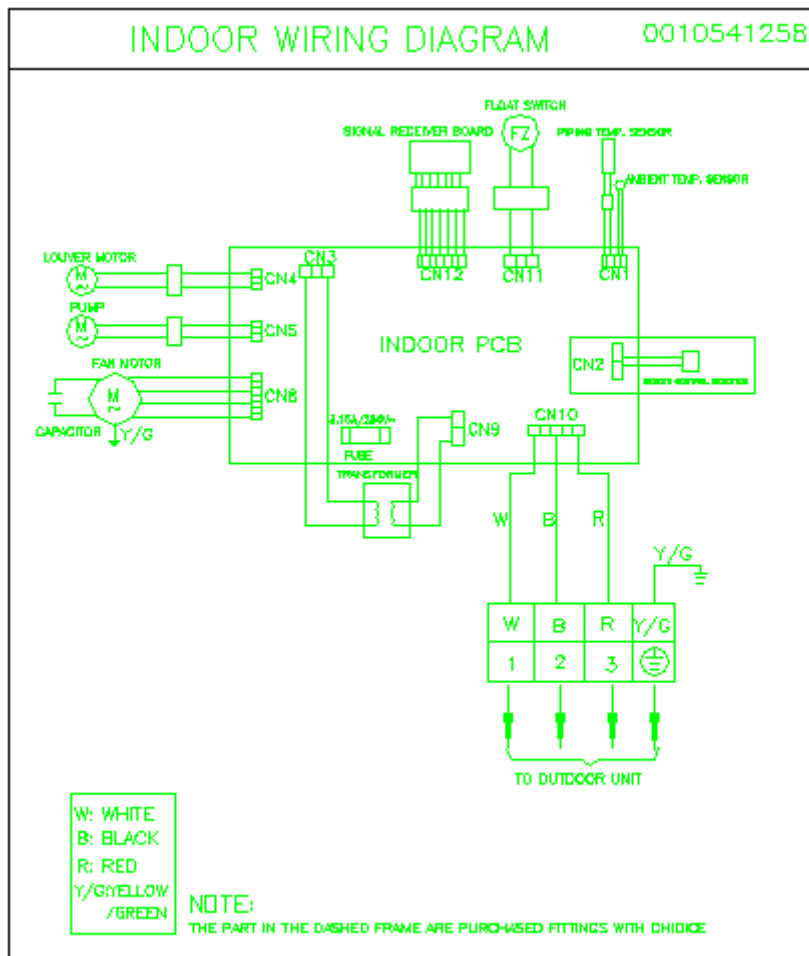

## 11.2 Circuit Diagram

### 11.2.1 Indoor unit Model: HBU-14H03

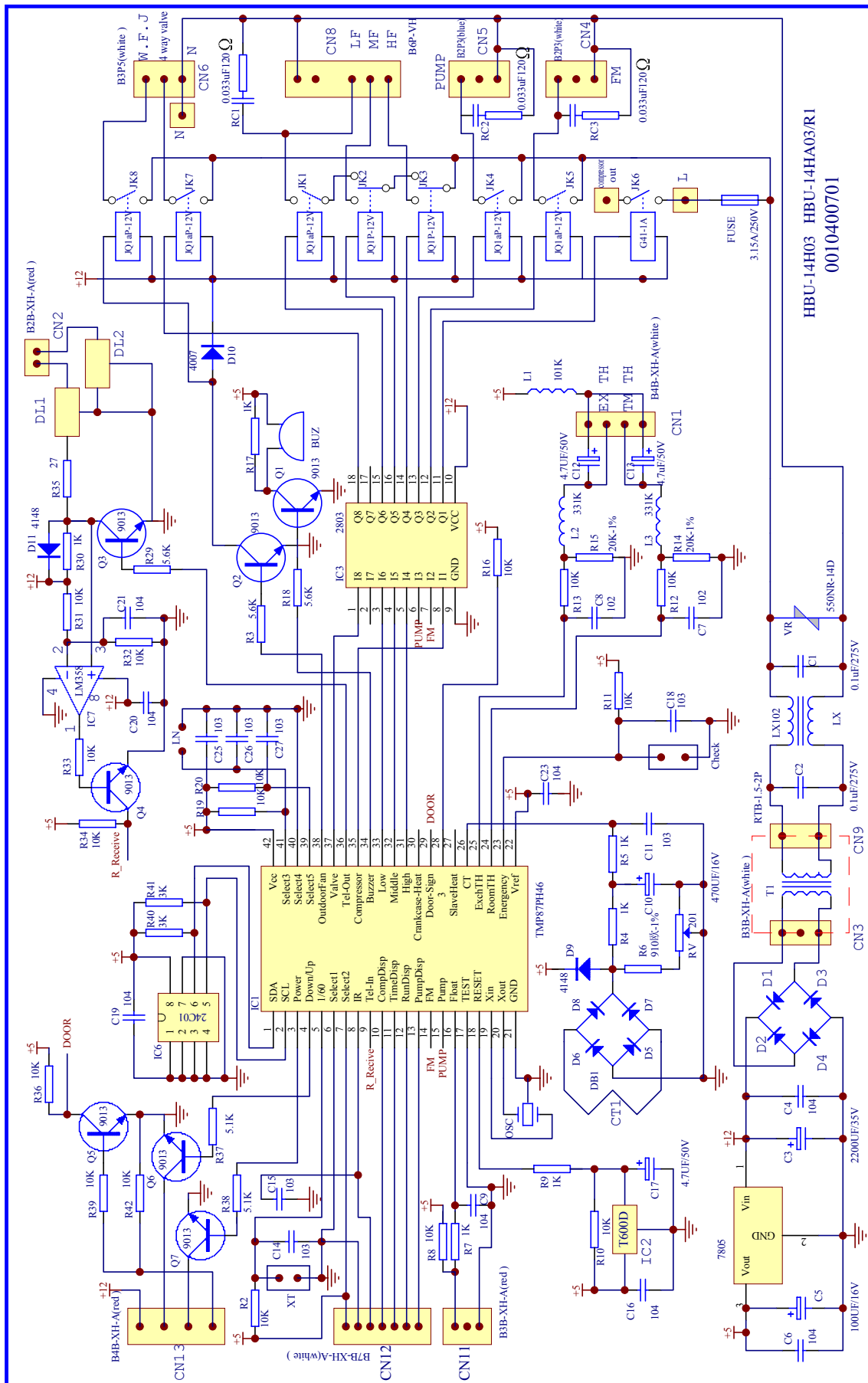

8. Electrical diagram

HBU-18HC03

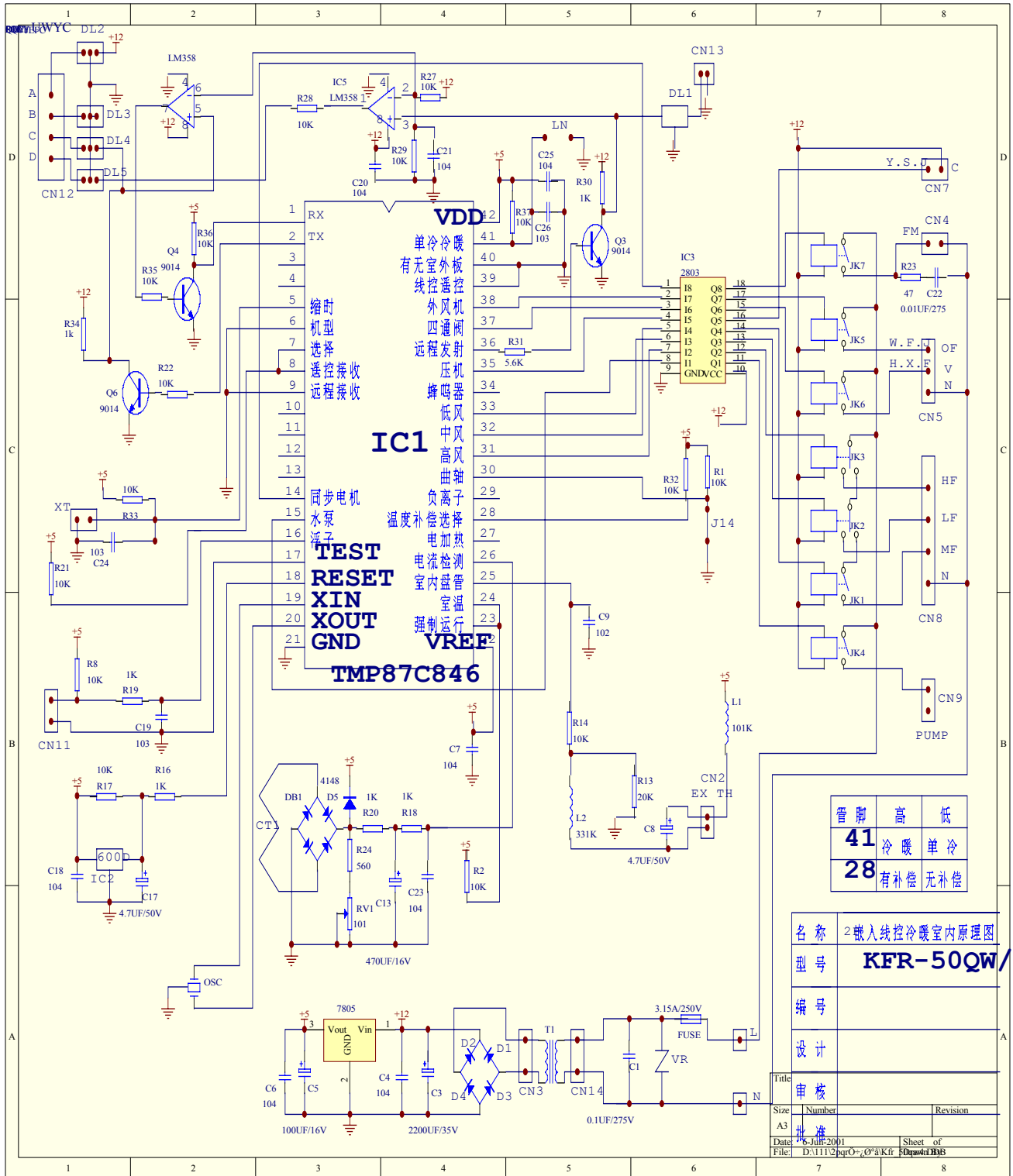

HBU-24H03 HBU-28HD03 HBU-36H03 HBU-42HD03

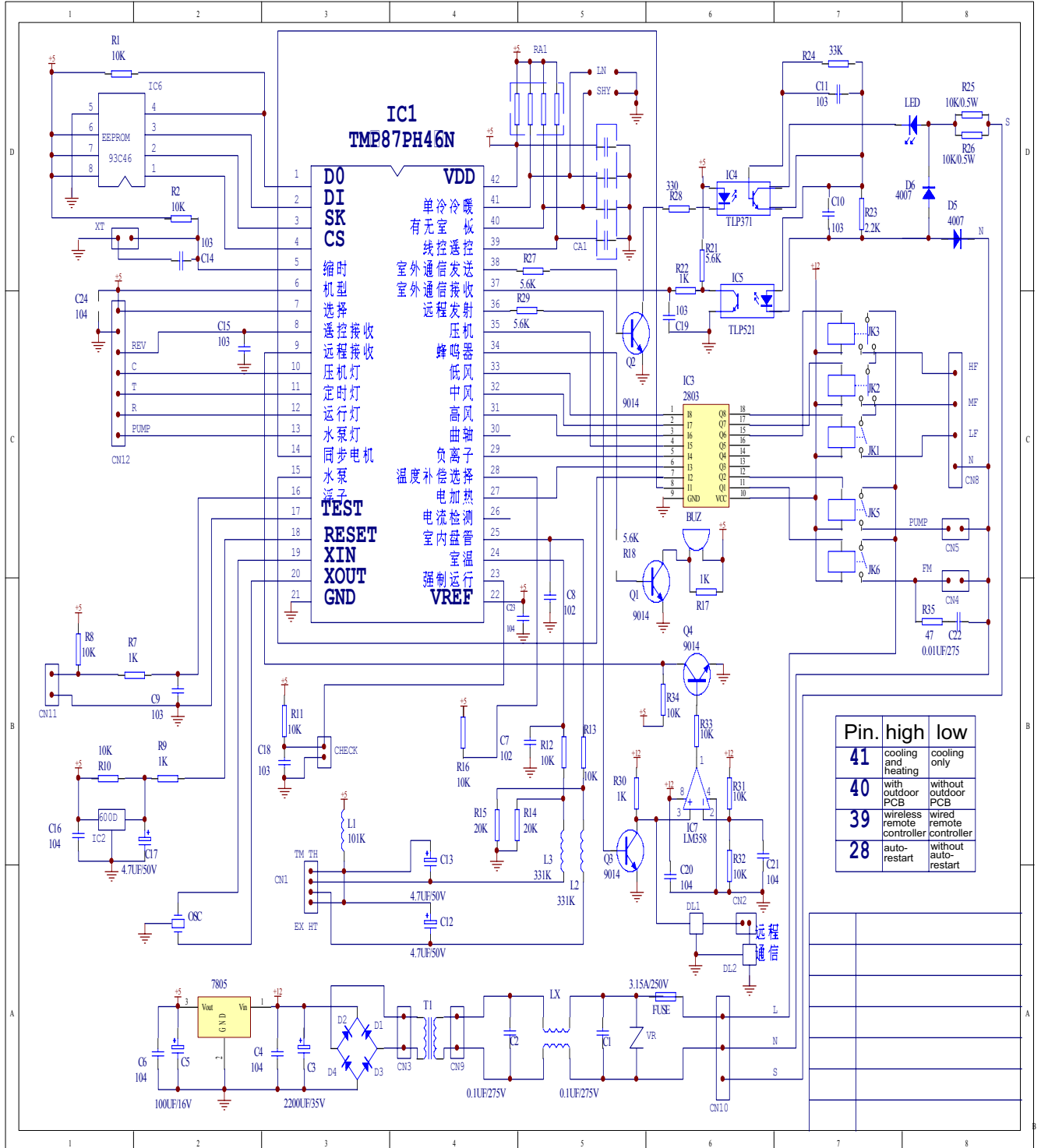

### 11.3 Thermostat chart (Sensor resistance-temperature graph)

Model: HBU-14H03 HBU-18HC03 HBU-24H03 HBU-28HD03  
HBU-36H03 HBU-42HD03

Indoor	Ambient temperature sensor	Coil temperature sensor
	23K	10K
Outdoor	Ambient temperature sensor	Coil temperature sensor
	5K	5K

The resistance-temperature charts are shown on the next pages.



R/T CHART OF SENSOR R25=23K  $\Omega$

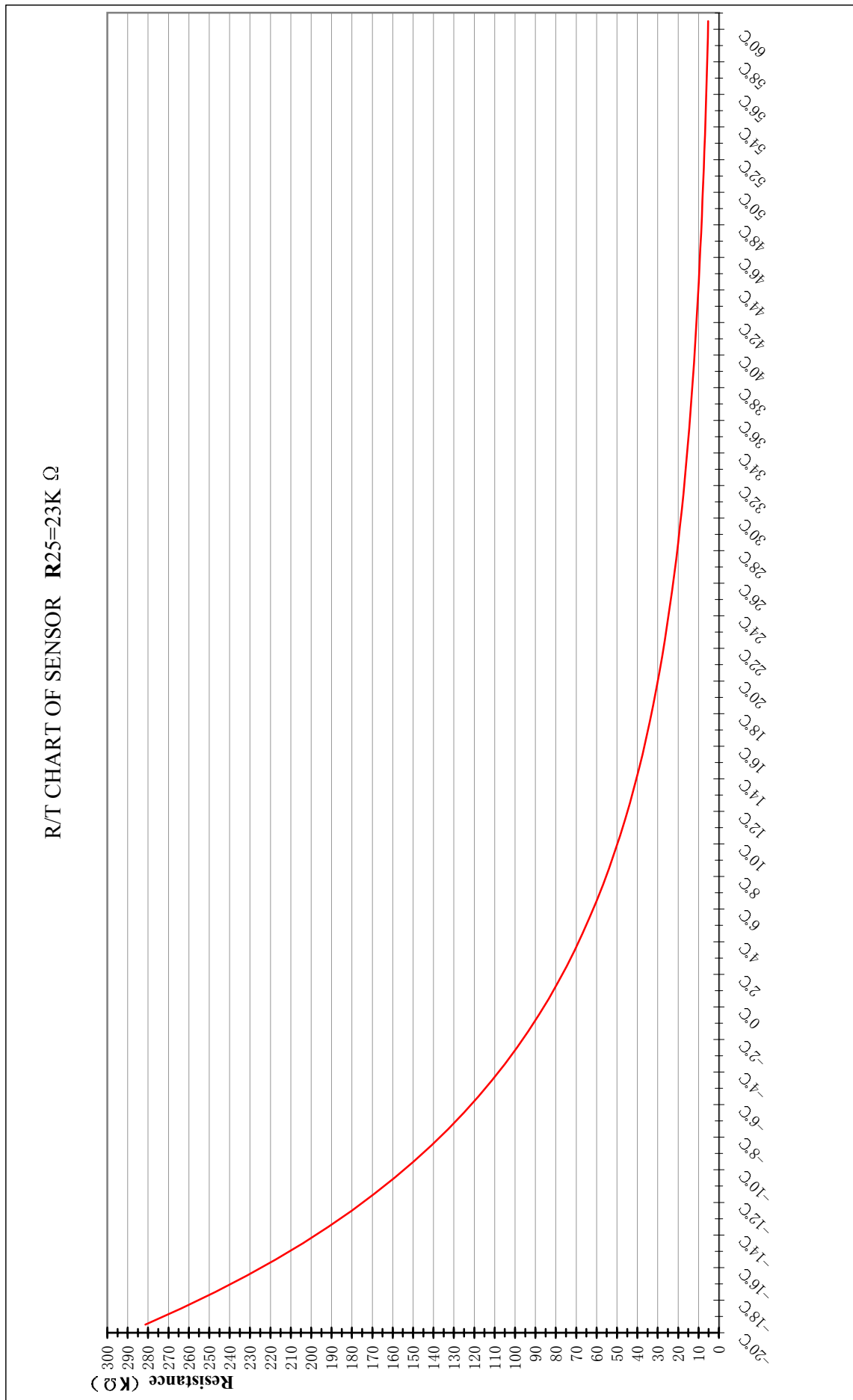

R/T CHART OF SENSOR R25 °C=5KΩ

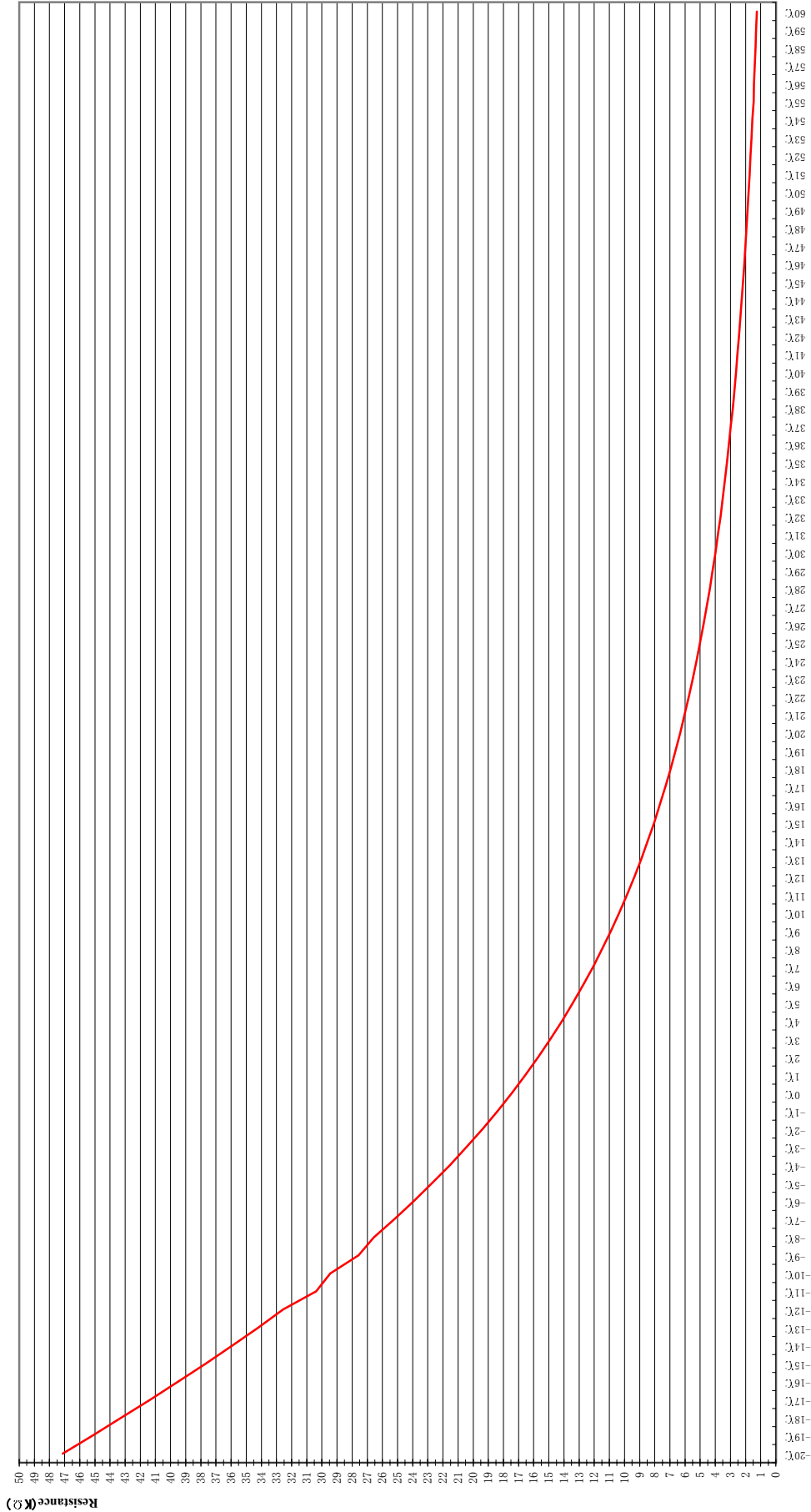

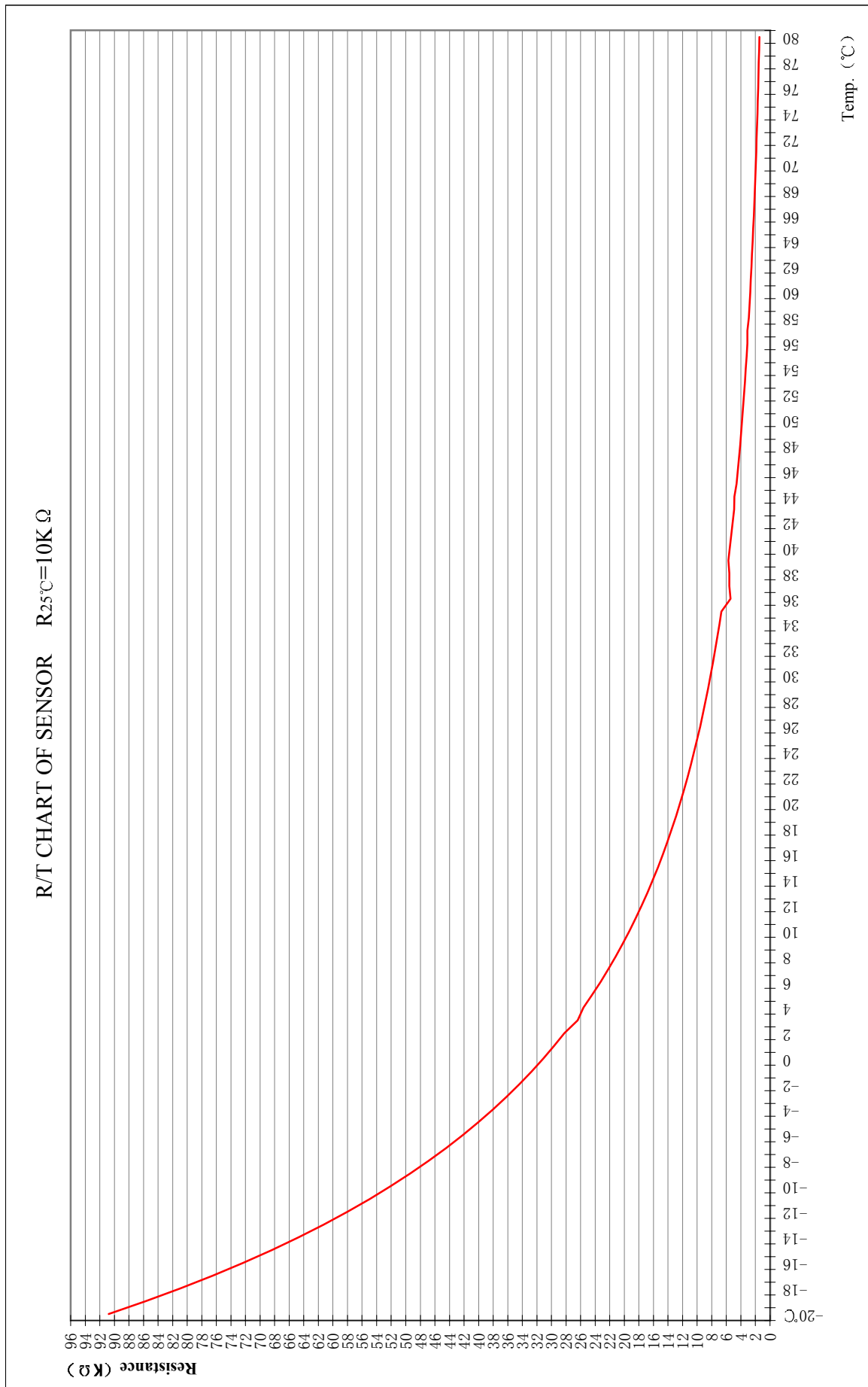

## 12 EXPLODED VIEWS & PARTS LISTS

### 12.1 Model HBU-14H03 indoor unit

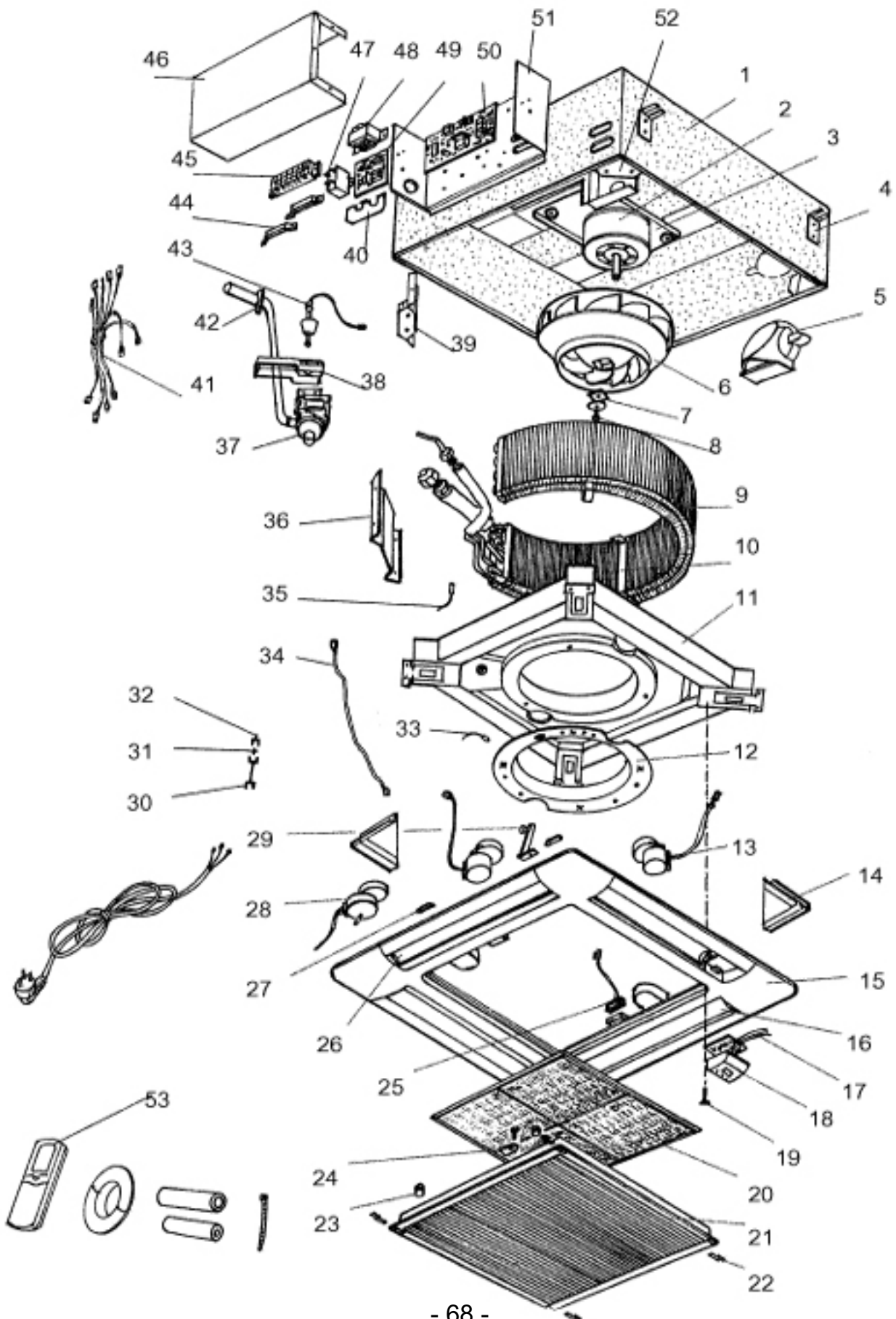

## EXPLODED VIEWS & PARTS LISTS

HBU-14H03

Part list of indoor unit

NO.	Name of part	Specialized Number	QTY	Remark
1	Guard assembly	0010800868	1	
2	Indoor fan motor	0010400705	1	*
3	Motor fix plate	0010100531	1	
4	Swing	001A13011049	4	
5	Ventilate duct	0010201129	1	
6	Centrifugal fan	0010250024	1	
7	Fan in-built part	0010250101	1	
8	Fix bolt	001A5002204A	1	
9	Evaporator assembly	0010800875	1	
10	Evaporator fix nip	0010100541	2	
11	Drain pan	0010201132	1	
12	Wind ring	0010201134	1	
13	Elevating motor	0010400706	2	*
14	Motor box cover	0010250066	4	
15	Panel	0010250049	1	
16	Airflow oriented board 1	0010250050	3	
17	PCB receiver	0010450083	1	*
18	Indicator light cover	0010250054	1	
19	Bolt 4*16 BTHC	001A5002088	4	
20	Air filter	0010250053	1	
21	Inlet grill	0010250052	1	
22	Fix bolt	0010250055	4	
23	Stationary rings	0010250058	4	
24	Axis sleeve	0010250065	8	
25	Switch fix clip	0010250060	1	
26	Airflow oriented board 2	0010250051	1	
27	Pull on line hole	0010250057	4	
28	Swing motor assembly	0010850097	1	*
29	Holding pole	0010250056	2	
30	Connecting rod	0010250062	3	
31	Coupler	0010250063	6	
32	Connection	0010250064	8	
33	Ambient temp. Sensor	001A3900159	1	*
34	Elevating wiring assembly	0010450032	1	
35	Pipe temp. sensor	001A3900006	1	*
36	Partition plate	0010100536	1	
37	Water pump motor	001A3000197	1	*
38	Water pump motor bracket	0010150041	1	
39	Fix plate	0010100532	1	
40	Lock plate	0010100528	1	
41	Indoor wiring assembly	0010450259	1	
42	Drainage pipe	001A14341141	1	
43	Level switch	001A3400160	1	*
44	Power line clip	001A14311292	2	
45	Terminal block	001A4000106	1	
46	Eletrical box cover	0010100538	1	
47	Fan motor capacitor 4 uf	001A3600018	1	*
48	Resumable transformer	001A3800141	1	*
49	Elevating control plate	0010400704	1	*
50	Indoor PCB	0010450174	1	*
51	Eletrical box	0010100537	1	
52	Wiring partition	0010800870	1	
53	Elevating remote controller	0010450042	1	*

Model HBU-14H03 outdoor unit

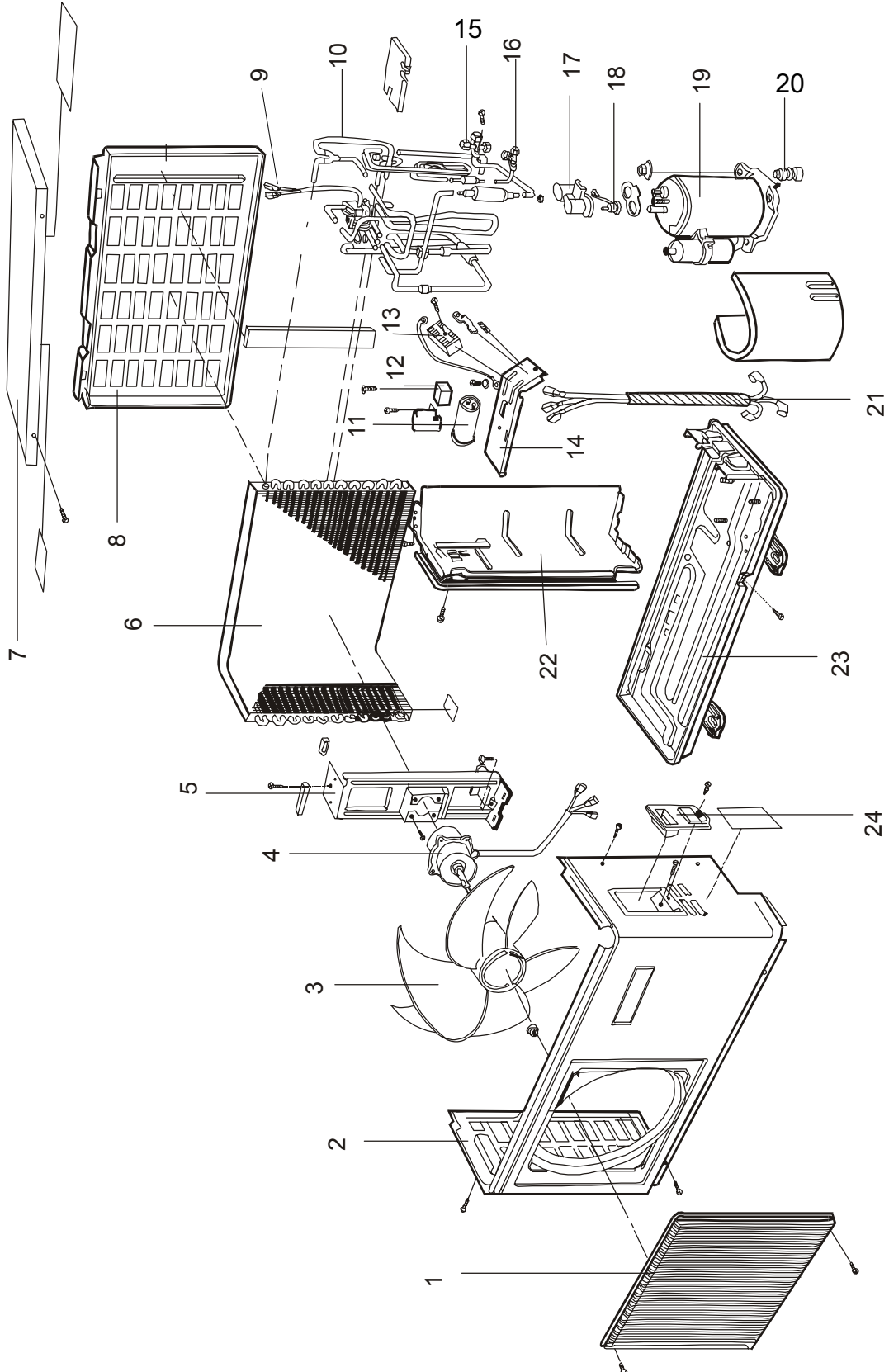

## EXPLODED VIEWS & PARTS LISTS

HBU-14H03

Part list of outdoor unit

NO.	Name of part	Part specialized code	QTY.	Remark
1	Front grille	001A1436043A	1	
2	Front panel	001A1101066	1	
3	Axial fan	001A2331030A	1	
4	Fan motor	001A3000089	1	*
5	Bracket for fan motor	001A1101068	1	
6	Condenser	0010750537	1	
7	Back grille	001A1101067	1	
8	Panel(top )	001A1101010	1	
9	4-way valve coil			
10	Tube assy.			
11	Capacitor for compressor	001A3600021	1	*
12	Capacitor for fan motor	001A3600007A	1	*
13	Terminal block	001A4000107	1	
14	Electric box	001A1301023	1	
15	Service valve	0010701913	1	*
16	Service valve	001A2500110	1	*
17	Service cover	001A1436042	1	
18	protector	001A3100117	1	
19	Compressor	0010750405	1	*
20	Rubber cushion	001A17561265	1	
21	Wire group	001A4400324	1	
22	Separating plate	001A1301429	1	
23	Bottom plate assy.	001A0100406	1	
24	Junction box	001A1436042	1	

12.2 Model HBU-18HC03 indoor unit

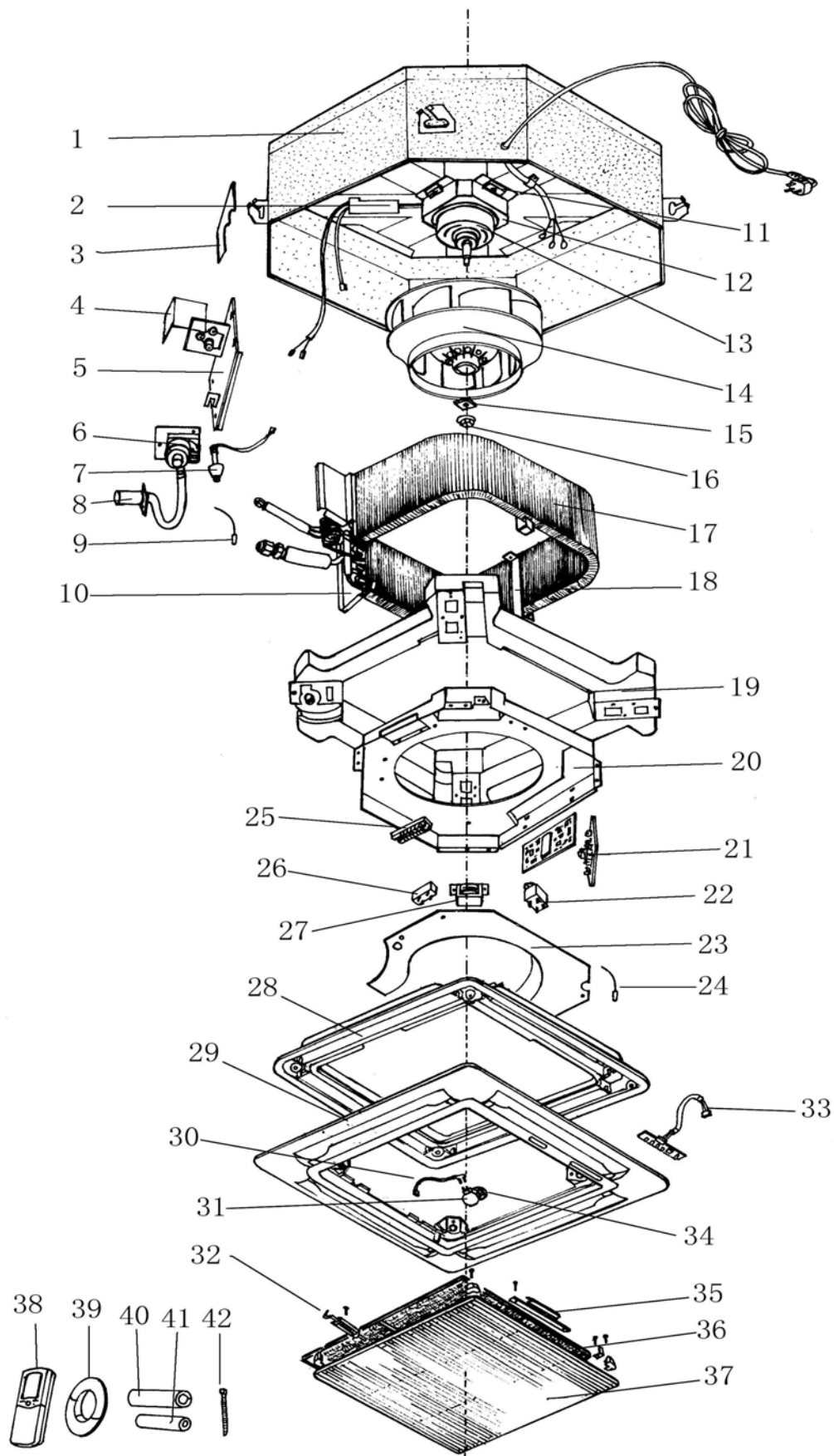



## EXPLODED VIEWS & PARTS LISTS

HBU-18HC03

Part list of indoor unit

No.	Part name	Specialized number	QTY.	Remark
1	Bottom plate assy.	10800033	1	
2	wiring fix plate	001A1301353	1	
3	baffle	001A1301367	1	
4	transparent plate	001A1439566A	1	
5	pump Bracket	001A1302753	1	
6	Water pump motor	0010450169	1	*
7	Float Switch	001A3400076	1	*
8	Drainage pipe	001A1439569	1	
9	Pipe temp. sensor	001A3900006	1	*
10	Evaporator Bracket	001A1301359	1	
11	Shock absorbing stud	001A1752763A	4	
12	Motor bracket	001A1301352	1	
13	Asynchronous Motor	001A3000093	1	*
14	Centrifugal fan	001A2300040	1	
15	Fan in-built part	001A1301966	1	
16	Flange screw nut	001A5102050	1	
17	Heat exchanger assy.	10750696	1	
18	Evaporator holder	001A1301356	2	
19	Drain pan assy.	001A0100306	1	
20	Electrical box	0010800499	1	
21	PCB	0010400018	1	*
22	Relay	001A3100073	1	*
23	Electrical box cover	001A1301448	1	
24	Ambient Temp. sensor	001A3900006	1	*
25	Terminal block	001A4000151	1	
26	Fan motor capacitor	001A3600018	1	*
27	Transformer	001A3800141	1	*
28	Panel pad	001A0100303	1	
29	Panel	001A1231163	1	
30	synchronous motor wire	0010400547	1	
31	synchronous motor	001A3000098	1	
32	Inlet grill bolt assy.	001A0100302	2	
33	Receive plate	10450229	1	*
34	Small cam	001A1436557	1	
35	Inlet grill bolt	001A1301344	1	
36	Air filter	001A2431057	1	
37	Inlet grill	001A1231165	1	
38	Remote Controller	0010400209	1	
39	Pipe hole cover	001A1752228A	1	
40	Heat insulation pipe1	001A1434575A	1	
41	Heat insulation pipe2	001A1434576A	1	
42	Cable clamp	001A6645001	1	

Model HBU-18HC03 outdoor unit

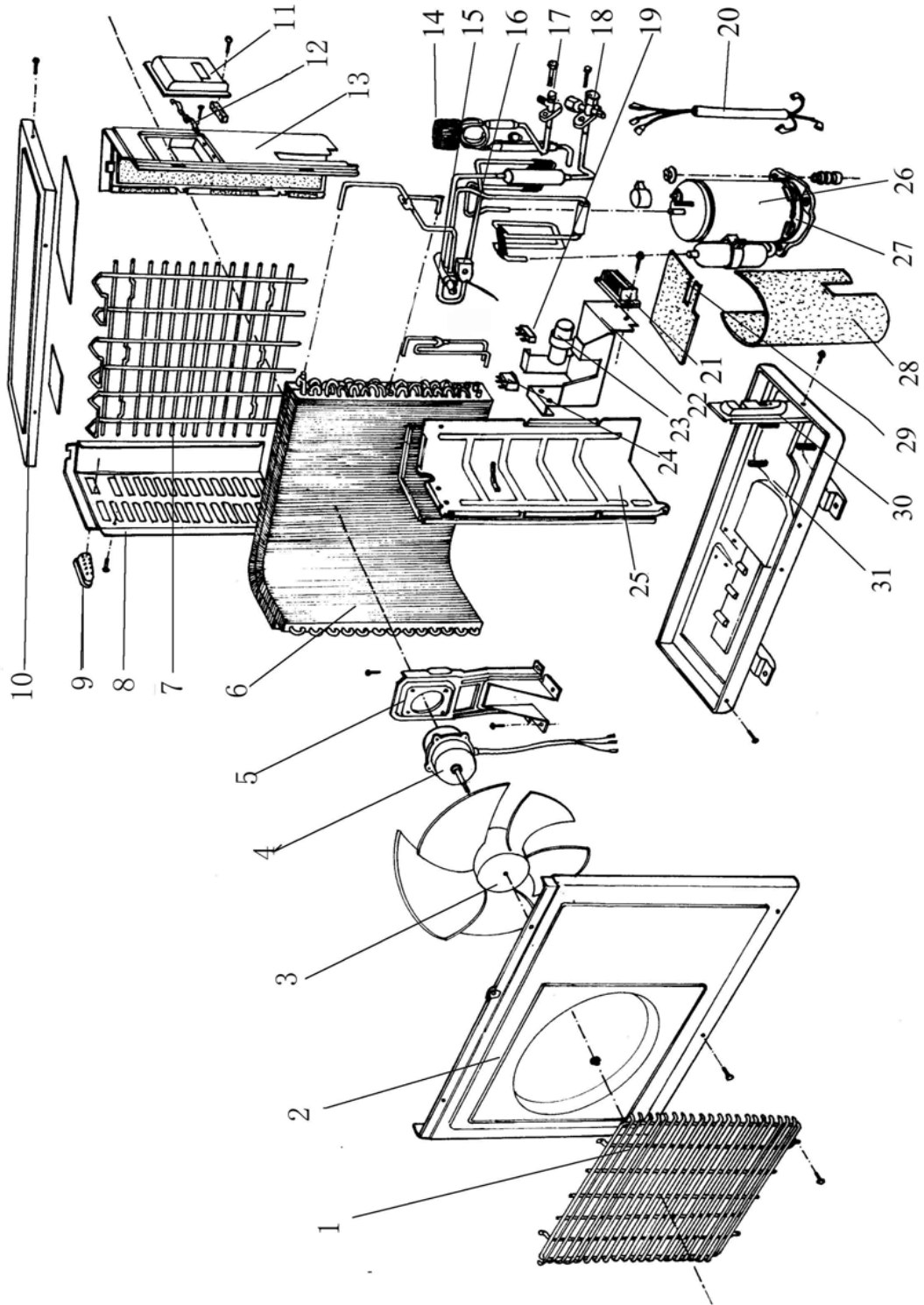

## EXPLODED VIEWS & PARTS LISTS

HBU-18HC03

Part list of outdoor unit

No.	Part name	Specialized number	QTY.	Remark
1	Front guard assy.	001A1303126A	1	
2	Front panel	001A0100123	1	
3	Axial fan	001A2331024	1	
4	Fan motor	001A3000069	1	*
5	Motor mounting plate	001A0100510	1	
6	Condenser assy.	0010750401	1	
7	Guard for heat exchanger	001A1303128	1	
8	Slide plate(left)	001A0100356	1	
9	Handle	001A1436182	1	
10	Top cover assy.	001A0100124	1	
11	Wire cover	001A0100125	1	
12	cable clamp	001A5731030 / 001A5731031	1/1	
13	Slide plate(right)	001A0100126	1	
14	Sensor	-----		
15	4-way valve	-----		
16	4-way valve winding	-----		
17	2-way valve	0010700027	1	*
18	3-way valve	0010700028	1	*
19	Connection block	001A4000011	1	
20	wire assy.	001A44000444	1	
21	Terminal block	001A4000115	1	
22	Electrical box	001A1301129A	1	
23	Running capacitor	001A3600030	1	*
24	Fan mortor capacitor	001A3600098	1	
25	Partition plate	001A0100127	1	
26	Compressor	0010700818	1	*
27	Heater	001A4500022A	1	
28	Sound insulation mat	001A1762340	1	
29	Heat insulation mat	001A1762341	1	
30	Valve pedestal	001A1301127	1	
31	Bottom cover assy.	001A0100237	1	

12.3 Model: HBU-24CA03/R1 HBU-28CA03/R1, indoor unit panel

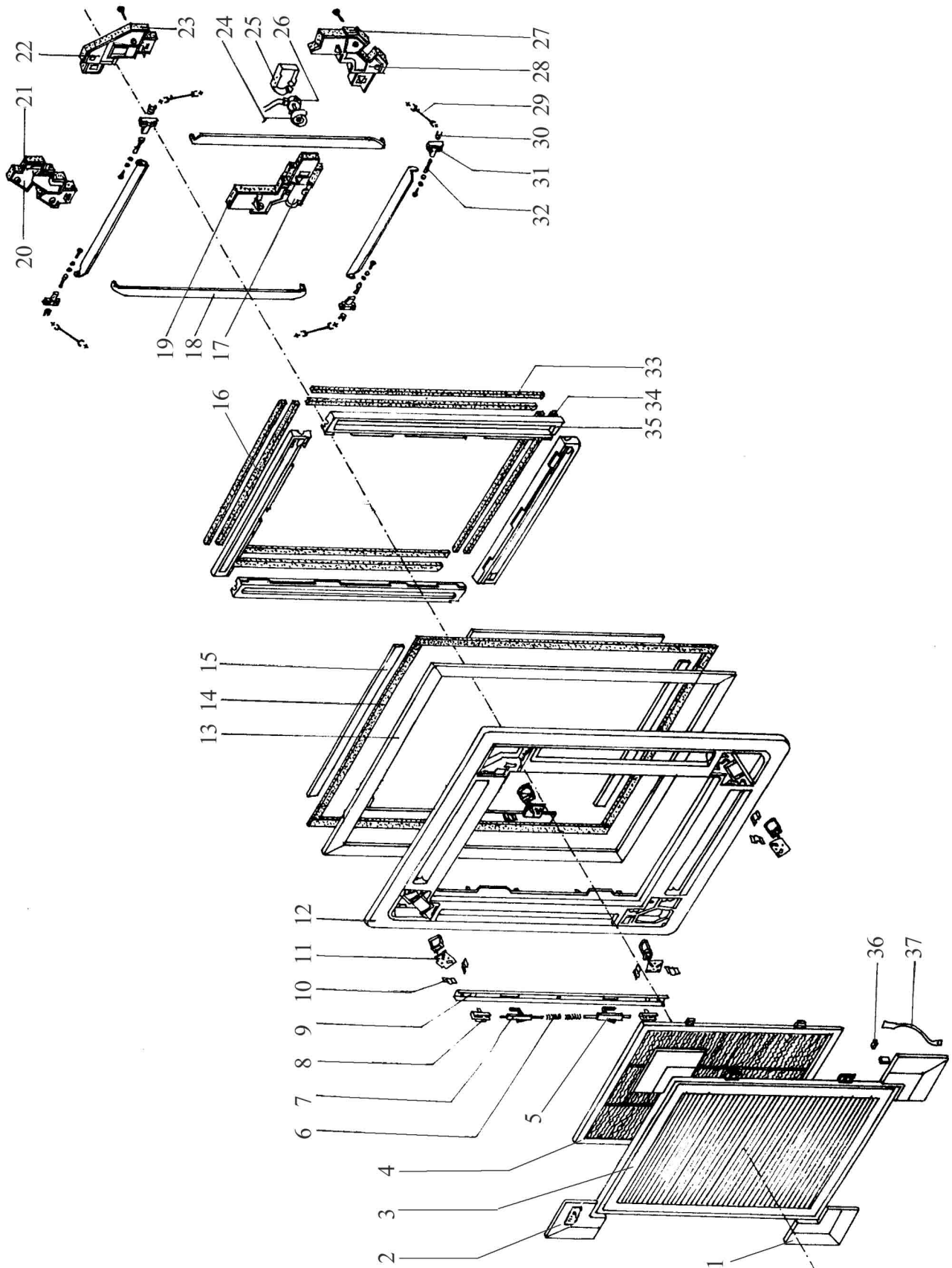

## EXPLODED VIEWS & PARTS LISTS

HBU-24H03 HBU-28HD03

Part list of the panel

No.	Part name	Specialized number	QTY.	Remark
1	corner cover	001A01001101	1	
2	corner cover(with indication lamp)	001A0100505	3	
3	inlet grill	001A1232228	1	
4	air filter	001A2400124	1	
5	lift switch(right)	001A1446847	1	*
6	spring	001A5501056	2	
7	lift switch(left)	001A1446846	1	*
8	fix clamp of air filter	001A1433845	2	
9	fortified tendon	001A1301740	1	
10	stator of corner cover	001A1301654	8	
11	stationary rings assy.	001A0100506	4	
12	panel	001A1232227	1	
13	cushion 1	001A17341107	4	
14	cushion 2	001A1742025	4	
15	cushion 3	001A17421163	4	
16	cushion 4	001A17561170	2	
17	inner corner cover assy.2	001A17421163	1	
18	fan blade assy.1	001A0100502	4	
19	cushion 5	001A17421016	1	
20	inner corner cover assy.3	001A0100665	1	
21	cushion 6	001A17421072	1	
22	inner corner cover assy.4	001A0100666	1	
23	cushion 7	001A1742018	1	
24	oriented cam	001A1431840	1	
25	box of synchronous motor	001A1436839	1	
26	synchronous motor	001A3000196	1	*
27	cushion 8	001A1742015	1	
28	inner corner cover assy.1	001A0100663	1	
29	connecting rod	001A1443834	3	*
30	link piece 2	001A1443837	6	
31	link piece 1	001A1431836	8	
32	link piece 3	001A1443838	8	
33	cushion 9	001A17561169	2	
34	cushion 10	001A17561281	2	
35	air outlet framework	001A1433850	4	
36	magnet	001A1300727	8	
37	nylon list	001A17451115	4	

Model HBU-24H03 HBU-28HD03 indoor unit

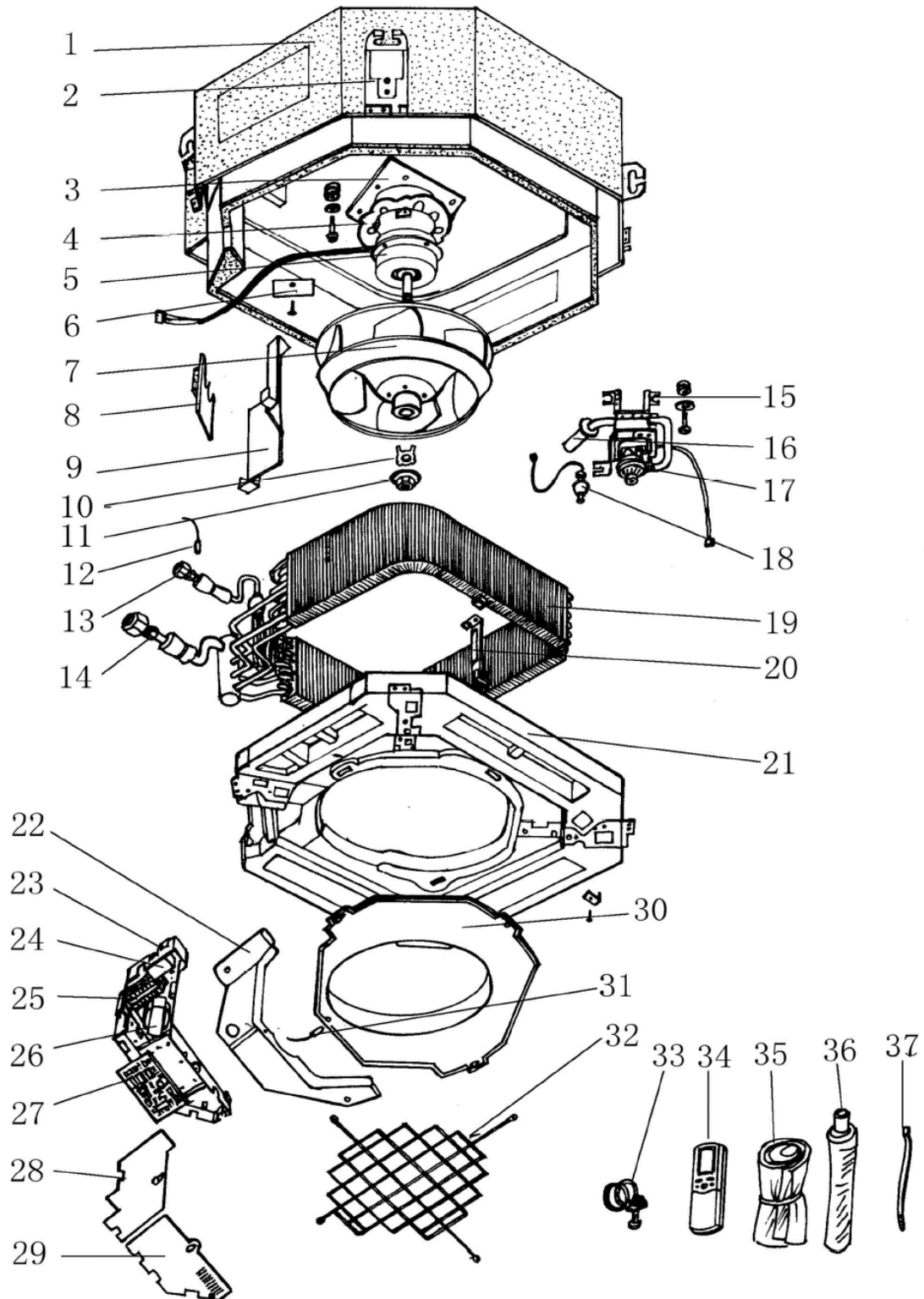

## EXPLODED VIEWS & PARTS LISTS

HBU-24H03 HBU-28HD03

Part list of indoor unit

No.	Part name	Specialized number	QTY.	Remark
1	bottom plate assy.	001A0100708	1	
2	swing	001A1301741	4	
3	fix plate of motor	001A1301743	1	
4	motor bracket	001A1301668	1	
5	indoor motor	001A3000219	1	*
6	press board	001A1301742	1	
7	indoor fan	001A2300088	1	
8	boarding	001A1301752	1	
9	fix plate of evaporator	001A1301751	1	
10	fan in-built part	001A1301710	1	
11	flange screw nut	001A5102015	1	
12	coil temp. sensor	001A3900159	1	*
13	liquid pipe assy.	001A0500498	1	
14	gas pipe assy.	001A0500497	1	
15	motor bracket of water pump	001A0100711	1	
16	drainage pipe	001A1434920	1	
17	motor of water pump	001A3000197	1	*
18	floating switch	001A3400160	1	*
19	evaporator assy.	001A0400154	1	
20	bracket of evaporator	001A1301750	2	
21	drain pan assy.	001A0900089	1	
22	bottom plate of electrical box	001A1301753	1	
23	electrical box	001A1232305	1	
24	fan capacitor	001A3600098	1	*
25	terminal block	001A4000151	1	
26	transformer	001A3800141	1	*
27	indoor PCB	0010400213	1	*
28	cover board (left)	001A1232306	1	
29	cover board (right)	001A1232307	1	
30	inlet fan circle	001A1431661	1	
31	ambient temp. sensor	001A3900158	1	*
32	guard grill	001A1301756	1	
33	block	001A13001077	1	
34	infrared remote controller	0010400256	1	*
35	heat preservation sleeve pipe 1	001A1434574A	1	
36	heat preservation sleeve pipe 2	001A1434925	1	
37	wire binding	001A6645007	6	

Model HBU-24H03 HBU-28HD03 outdoor unit

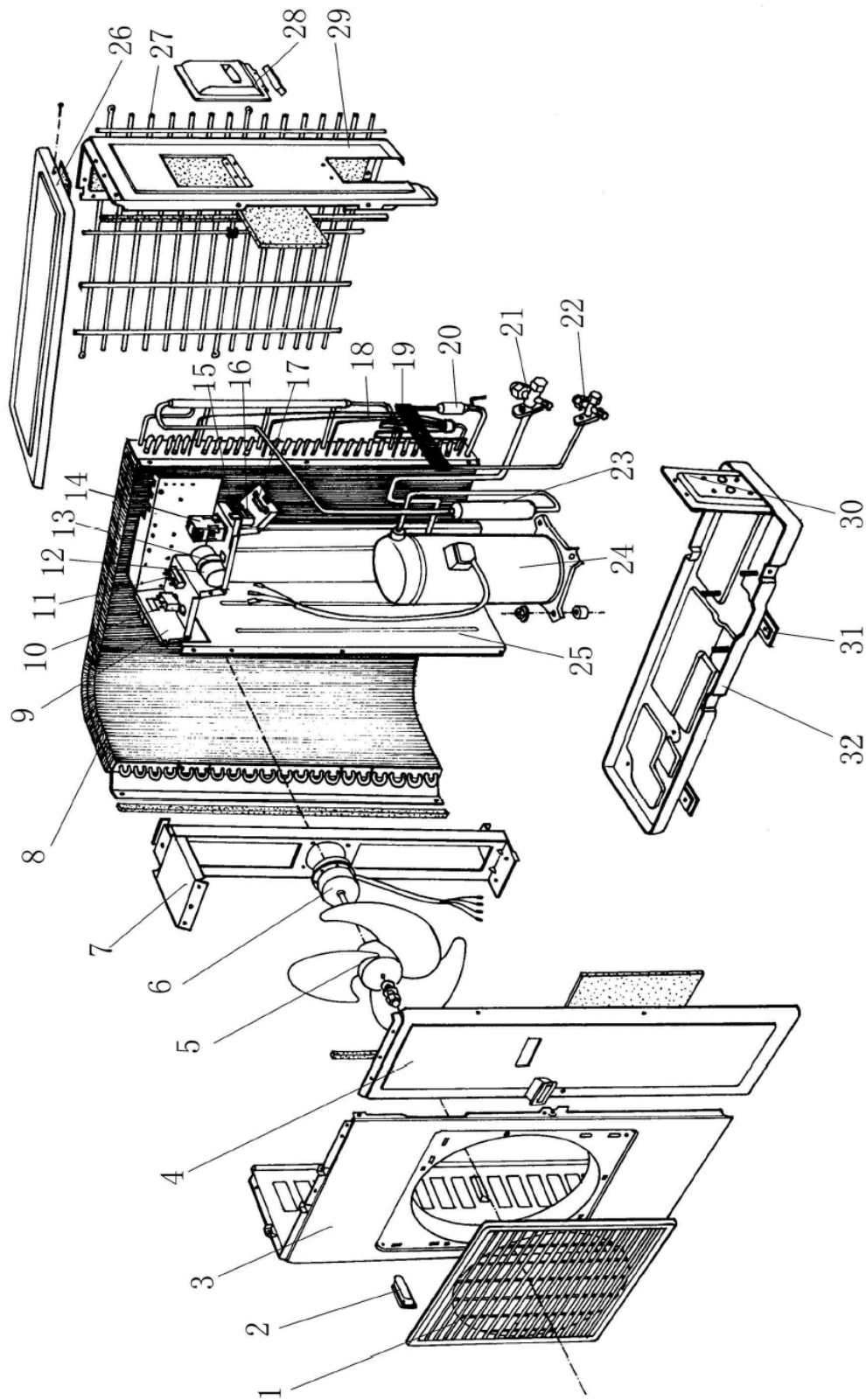



## EXPLODED VIEWS & PARTS LISTS

HBU-24H03 HBU-28HD03

Part I

ist of outdoor unit

No.	Part name	Specialized number	QTY.	Remark
1	front guard grill assy.	001A0100122	1	
2	handle	001A1436160	2	
3	front panel	001A0100261	1	
4	service panel	001A0100524	1	
5	axial fan	001A5402022	1	
6	outdoor motor	001A3000202	1	*
7	motor bracket	001A0100530	1	
8	condenser assy.	001A0400139	1	
9	electrical box	001A1301453	1	
10	fan capacitor	001A3600018	1	*
11	connection block	001A4000011	1	
12	runing capacitor	001A3600030	1	*
13	clip of capacitor	0010100001	1	
14	AC contactor	001A3900161	1	*
15	terminal block	001A4000151	1	
16	power connection block	001A4000110	1	
17	wire clip	001A5731054	1	
18	gas discharge tube assy.	001A0500368	1	
19	gas charge tube assy.	001A0500433	1	
20	filter	001A2411023	1	
21	3-way valve	001A2500083	1	*
22	2-way valve	001A2500082	1	*
23	muffle	001A2111911	1	
24	compressor	001A2000201	1	*
25	partition plate	001A0100350	1	
26	top cover plate	001A0100264	1	
27	back guard grill	001A0100109	1	
28	wiring box cover	001A0100394	1	
29	right plate assy.	001A0100390	1	
30	valve seat	001A1301506	1	
31	arm	001A1301117	2	
32	bottom plate assy.	001A0100351	1	
33	wiring harness	001A4400742	1	

HBU-28HD03

24	compressor	0010700989	1	
----	------------	------------	---	--

12.4 Model: HBU-36H03 HBU-42HD03, indoor unit panel

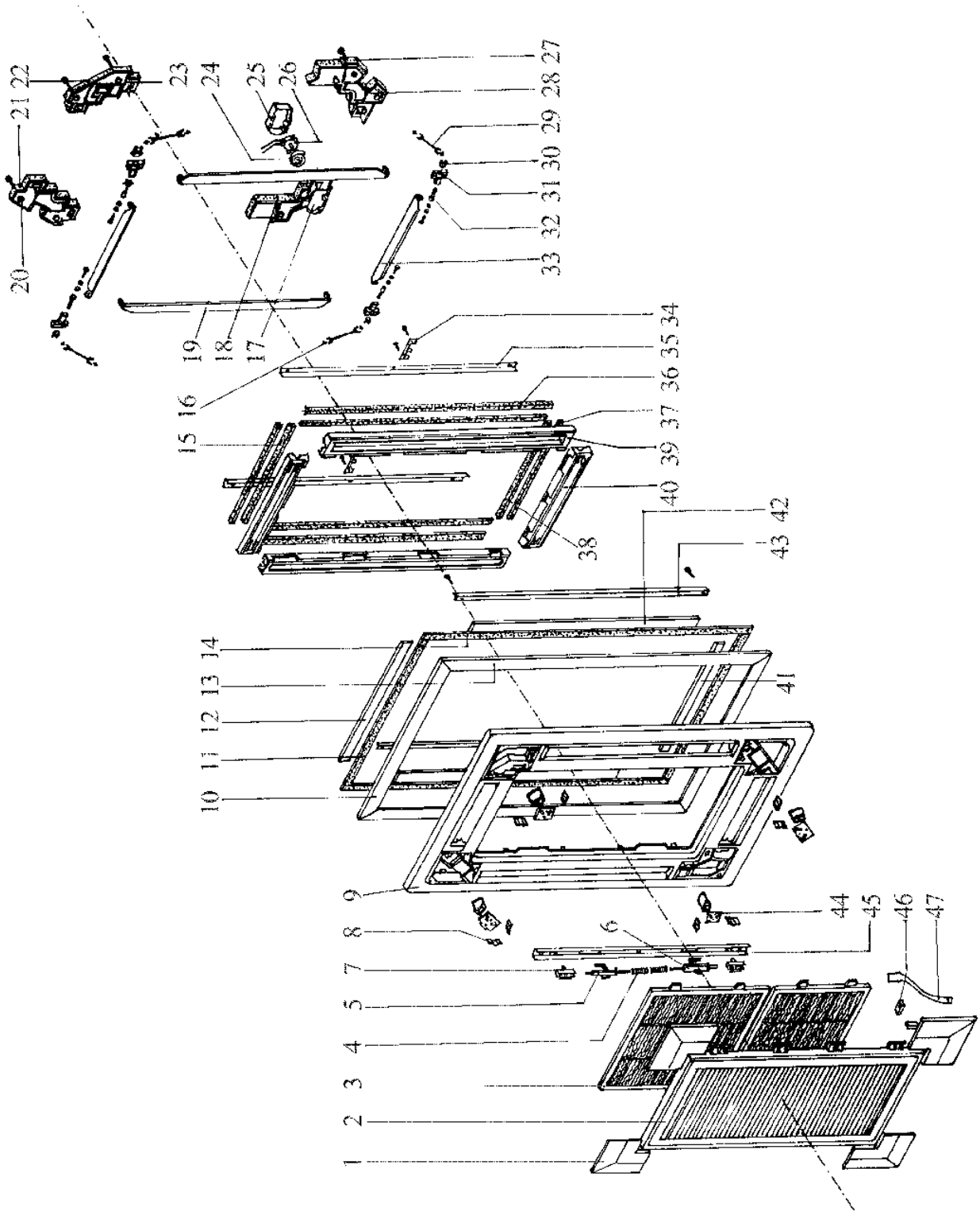

## EXPLODED VIEWS & PARTS LISTS

HBU-36H03 HBU-42HD03

Part list of panel

No.	Part name	Specialezed number	QTY.	Remark
1	corner cover	0100505	3	
2	inlet grill	1232241	1	
3	air filter	2400110	2	
4	spring	5501056	2	
5	lift switch(right)	1446847	1	*
6	lift switch(left)	1446846	1	*
7	fix clamp of air filter	1433845	4	
8	stator of corner cover	1301654	8	
9	panel	1232242	1	
10	cushion 1	17341107	2	
11	foamy cushion 1	1742025	6	
12	cushion 2	17341104	2	
13	cushion 3	17341106	2	
14	foamy cushion 2	1742026	2	
15	foamy cushion 3	17561169	2	
16	connection	1443835	6	
17	inner corner cover assy.2	17421163	1	
18	cushion 4	1742016	1	
19	fan blade assy.2	0100503	2	
20	inner corner cover assy.3	0100665	1	
21	cushion 5	17421072	1	
22	cushion 6	1742018	1	
23	inner corner cover assy.4	0100666	1	
24	oriented cam	1431840	1	
25	box of synchronous motor	1436839	1	
26	synchronous motor	3000196	1	
27	cushion 7	1742015	1	
28	inner corner cover assy.1	0100663	1	
29	connecting rod	1443834	3	
30	link piece 2	1443837	6	*
31	link piece 1	1431836	8	*
32	link piece 3	1443838	8	*
33	fan blade assy.1	0100502	2	
34	fix plate assy.	0100631	2	
35	fortified tendon 2	1301653	2	
36	cushion 8	17561167	2	
37	cushion 9	17561281	2	
38	cushion 10	17561168	2	
39	frame of outlet grill 2	1433851	2	
40	frame of outlet grill 1	1433850	2	
41	cushion 11	17561170	1	
42	cushion 12	17341105	2	
43	fortified tendon 1	1301652	2	
44	ring assy.	0100506	4	*
45	fortified tendon 3	1301655	1	
46	magnet	1300727	8	*
47	nylon list	17451115	4	

Model HBU-36H03 HBU-42HD03 indoor unit

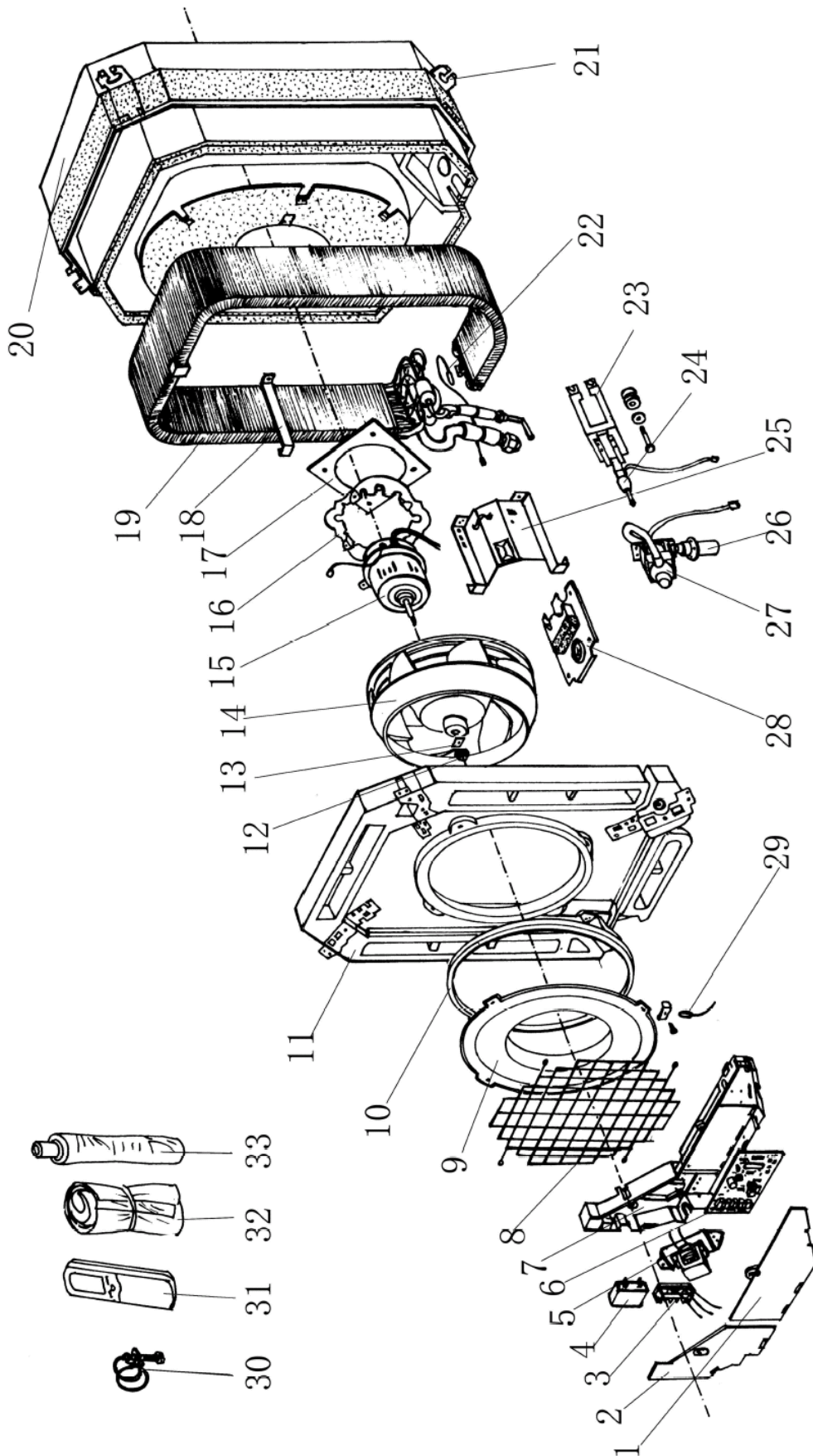

## EXPLODED VIEWS & PARTS LISTS

HBU-36H03 HBU-42HD03

Part list of indoor unit

No.	Part name	Specialized number	QTY.	Remark
1	electrical box cover2	001A1232307	1	
2	electrical box cover1	001A1232306	1	
3	terminal block	001A4000151	1	
4	fan mortor capacitor	001A3600232	1	*
5	transformer	001A3800141	1	*
6	PCB	0010400213	1	*
7	electrical box	001A1232305	1	
8	fan motor filter	001A1301815	1	
9	wind ring	001A1231308	1	
10	drain pan accessory	001A1434927	1	
11	drain pan assy.	001A0900066	1	
12	flange screw nut	001A5102015	1	
13	fan in-built part	001A1301710	1	
14	centrifugal fan	001A2300083	1	
15	motor	001A3000195	1	*
16	motor bracket	00A1301668	1	
17	motor holder	001A1301669	1	
18	evaporator holder	001A1301678	2	
19	heat exchanger assy.	001A0400151	1	
20	bottom plate assy.	001A0100507	1	
21	hanging	001A1101187	4	
22	pipe temp. sensor	001A3900006	1	*
23	pump bracket	001A1301677	1	
24	float switch	001A3400160	1	*
25	evaporator holded plate	001A01001096	1	
26	drainage hose	001A1434920	1	
27	water pump	001A3000197	1	*
28	pipe holder plate	001A1301659	1	
29	environment temperature sensor	001A3900159	1	*
30	clip	001A1439315	1	
31	remote controller	0010400256	1	
32	heat insulation pipe1	001A1734260	1	
33	heat insulation pipe2	001A1734261	1	

HBU-36H03 HBU-42HD03 Outdoor Units

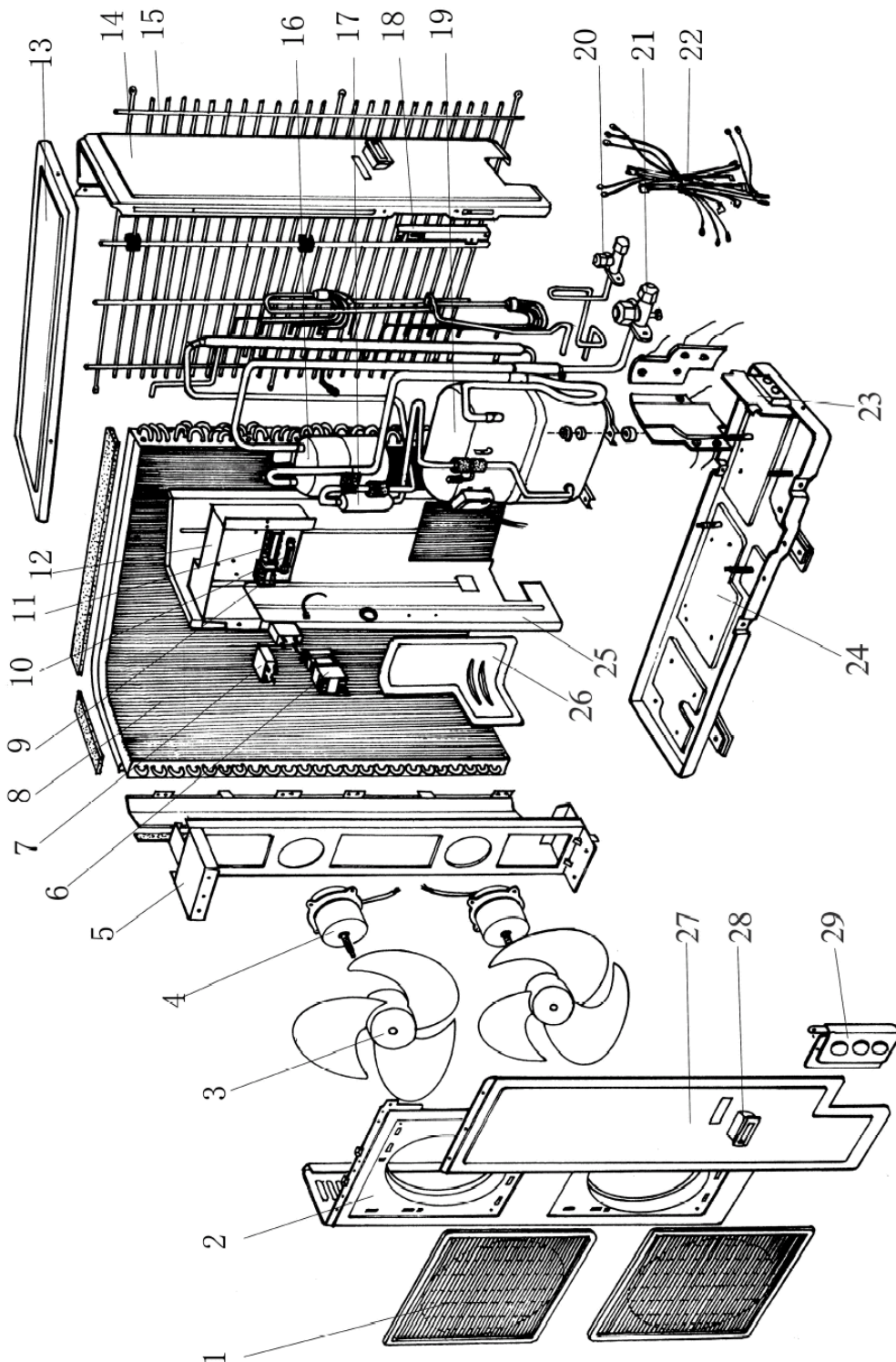

## EXPLODED VIEWS & PARTS LISTS

HBU-36H03 HBU-42HD03

Part list of outdoor unit

No.	Part name	Specialized number	QTY.	Remark
1	inlet grill	001A0100122	2	
2	front panel	001A0100492	1	
3	axial fan	001A5402022	2	
4	outdoor motor	0010450279	2	*
5	bracket of outdoor unit	001A0100740	1	
6	AC contactor	001A3100025	1	*
7	capacitor of fan motor	001A3600018	2	*
8	condenser	001A0400165	1	
9	wiring connection block	001A4000011	1	
10	wiring clamp	001A5701062	1	
11	terminal block	001A4000158	1	
12	electrical box	001A1301708	1	
13	top cover assy.	001A0100827	1	
14	right plate assy.	001A0100733	1	
15	back guard assy.	001A0100495	1	
16	liquid tank	001A2000175	1	
17	muffle	001A2400128	1	
18	fixing plate	001A1301465	1	
19	compressor	001A2000200	1	*
20	2-way valve	001A2500149	1	*
21	3-way valve	001A2500150	1	*
22	wiring	001A4400747	1	
23	valve seat	001A1301762	1	
24	bottom plate assy.	001A0100735	1	
25	partition plate	001A0100734	1	
26	cushion of partition plate	001A17561212	1	
27	service panel	001A1301707	1	
28	handle	001A1436160	1	
29	support panel	001A1301763	1	

HBU-36H03

19	compressor	0010750196	1	
----	------------	------------	---	--

### 13 PERFORMANCE CURVES

HBU-14H03

a Cooling capacity graph

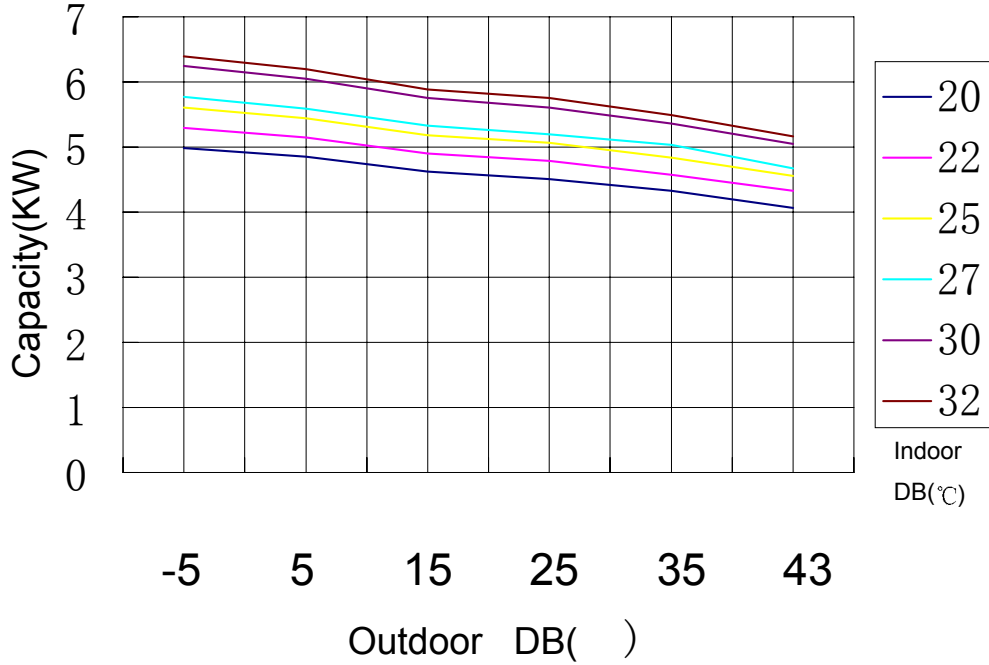

b EER graph

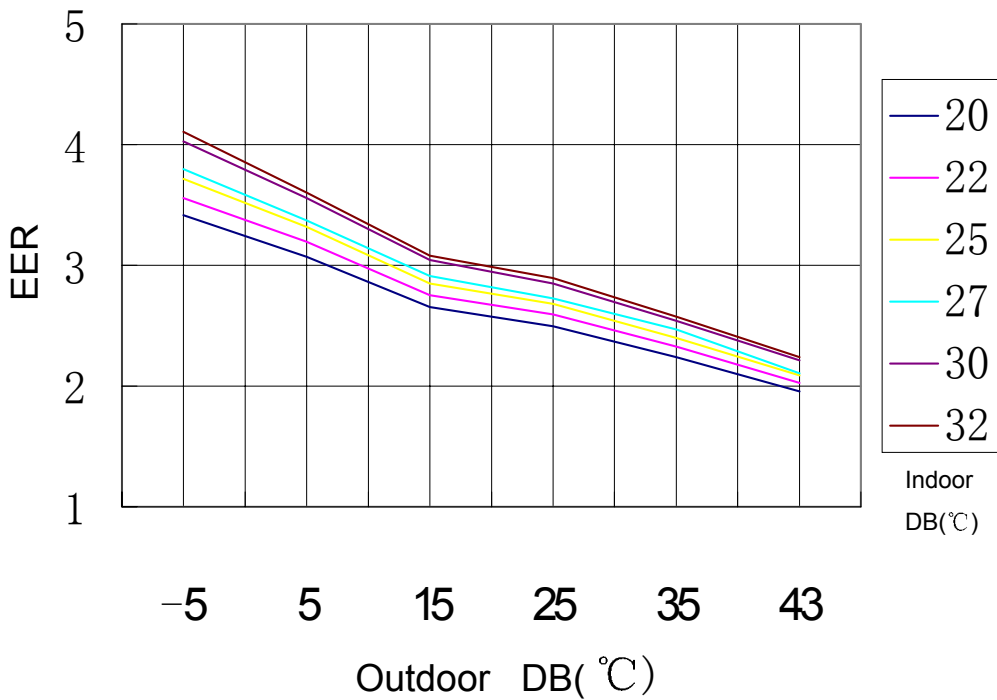



HBU-18HC03

Cooling capacity graph

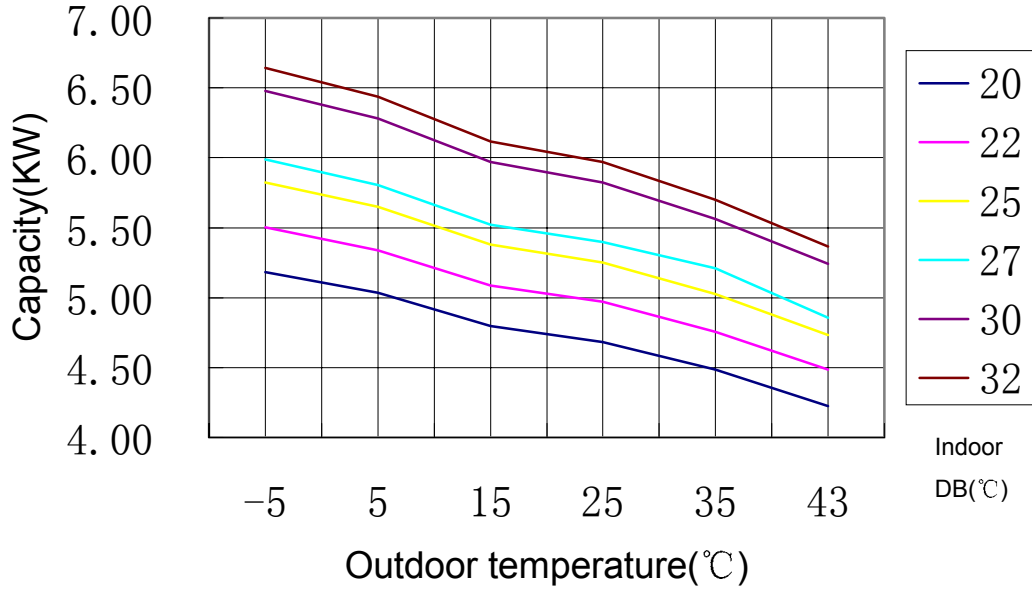

EER graph

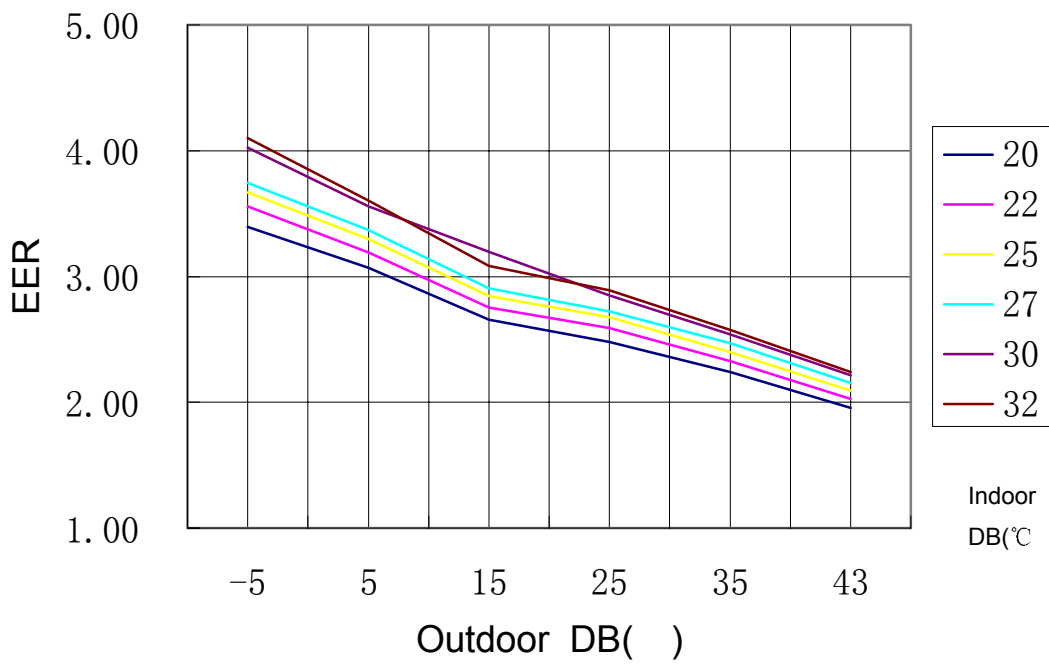

HBU-24H03

a Cooling capacity graph

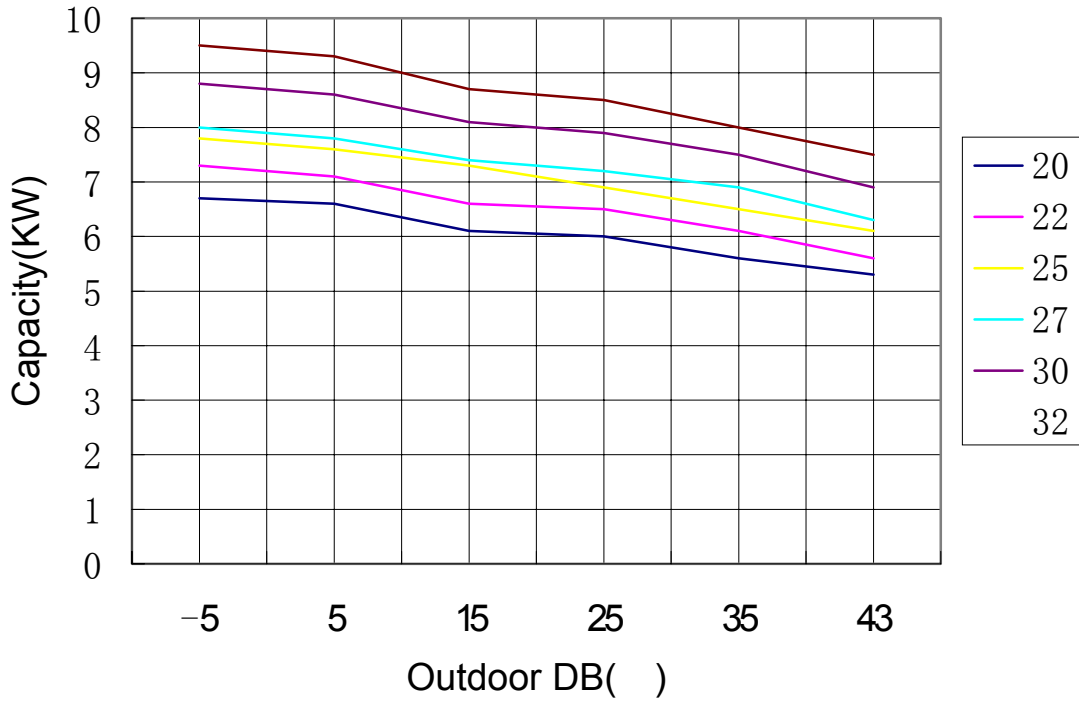

b

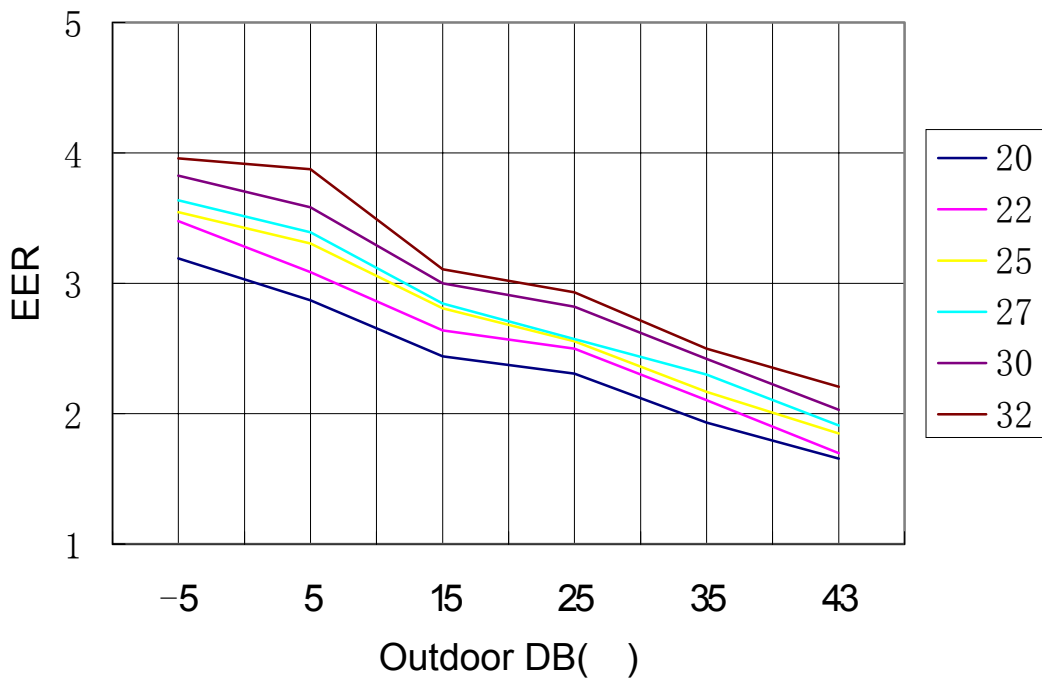

HBU-28HD03

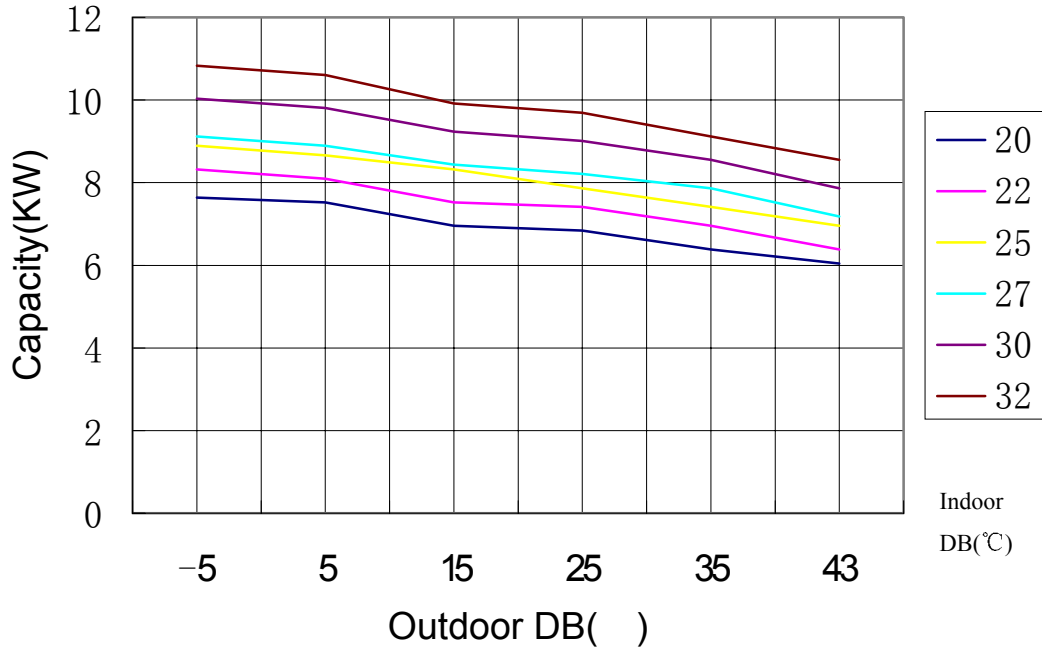

EER graph

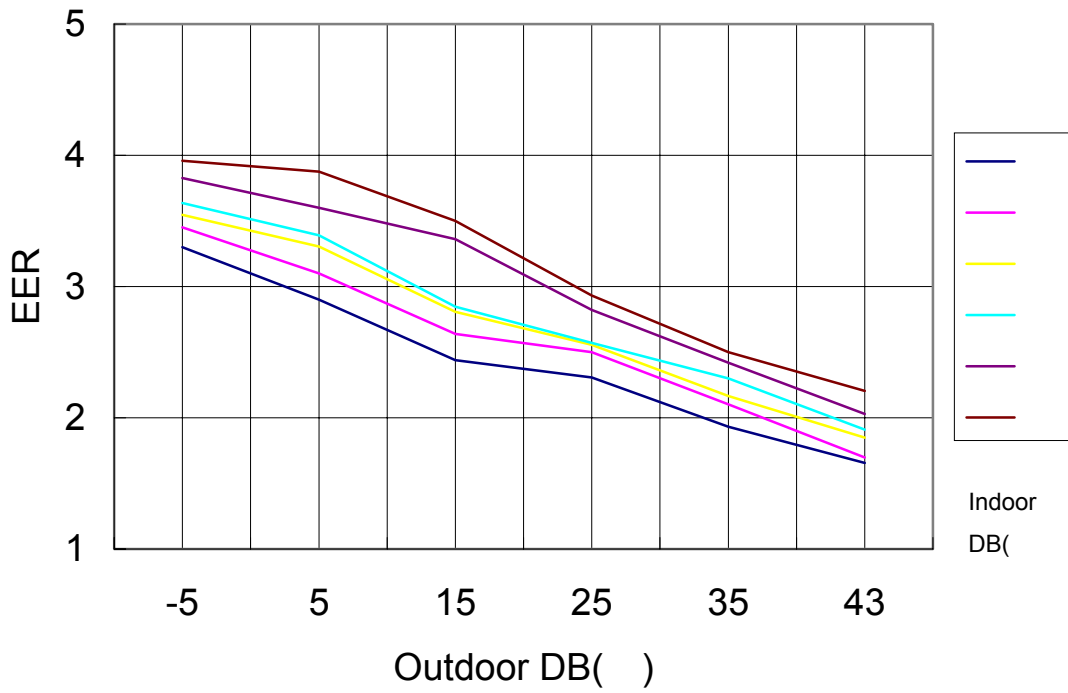

HBU-36H03

Cooling capacity graph

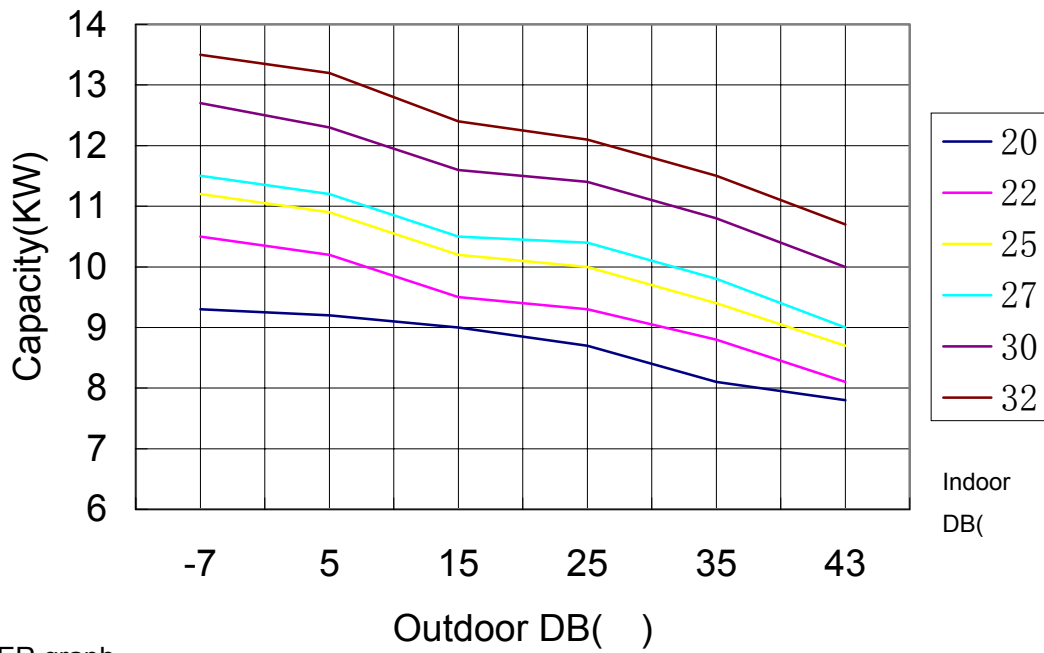

EER graph

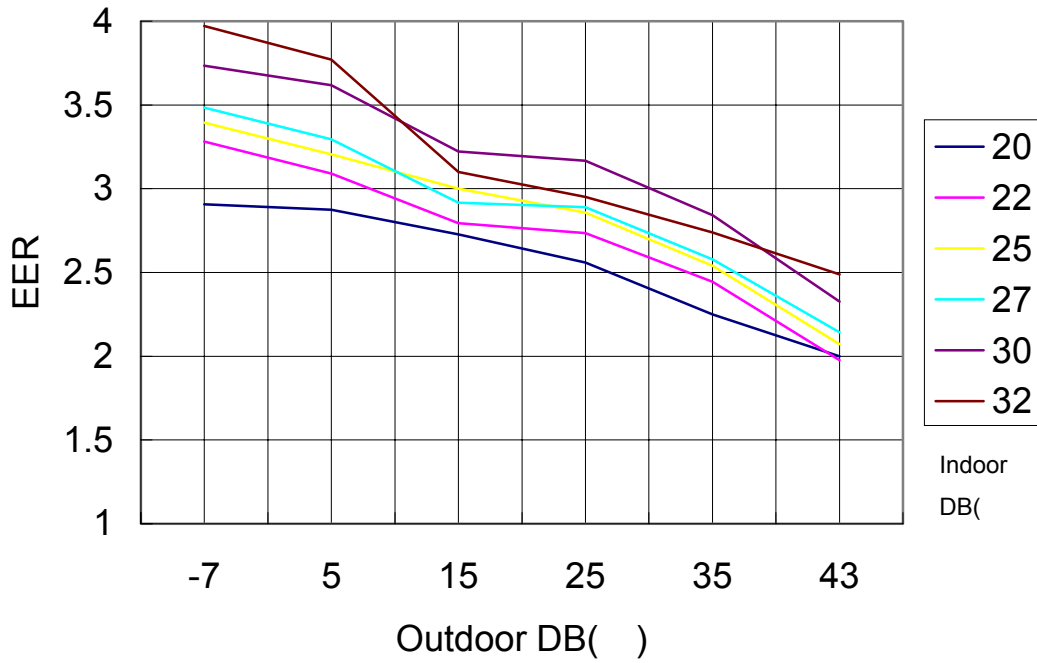

HBU-42HD03

a Cooling capacity graph

Cool capacity graph

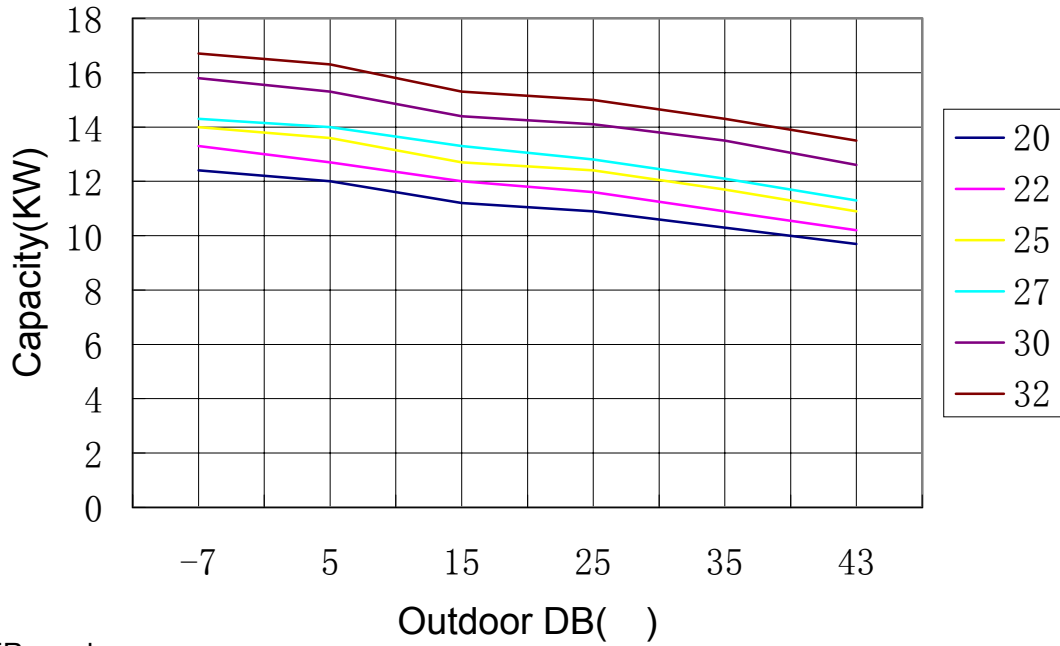

b EER graph

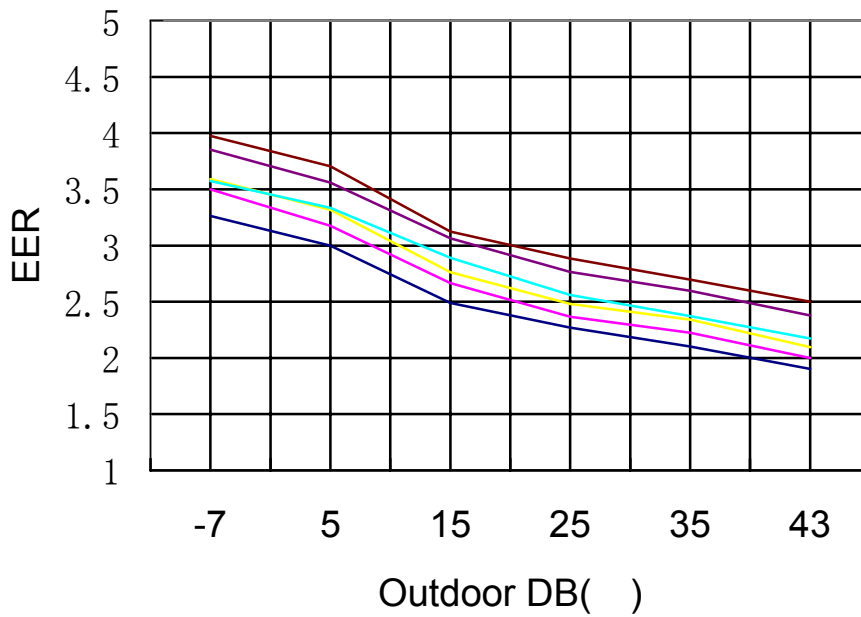

# 14 NOISE LEVEL TEST CHART

working mode: cooling

### HBU-14

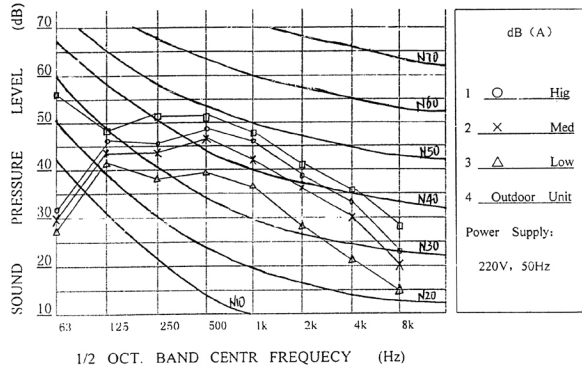

### HBU-18

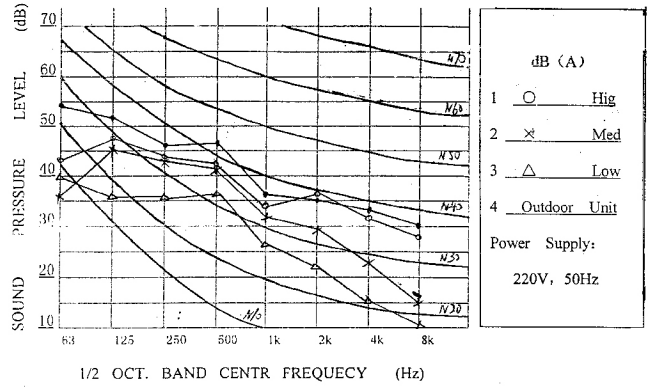

### HBU-24

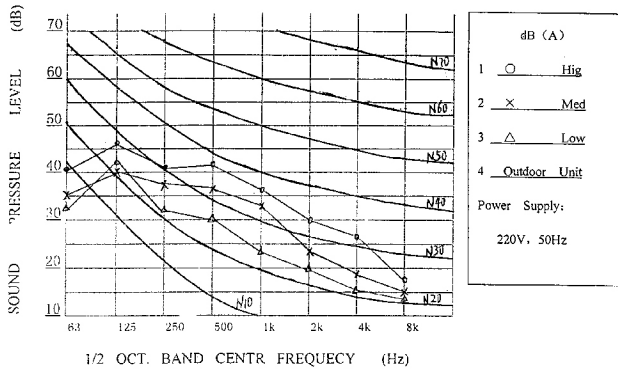

### HBU-28

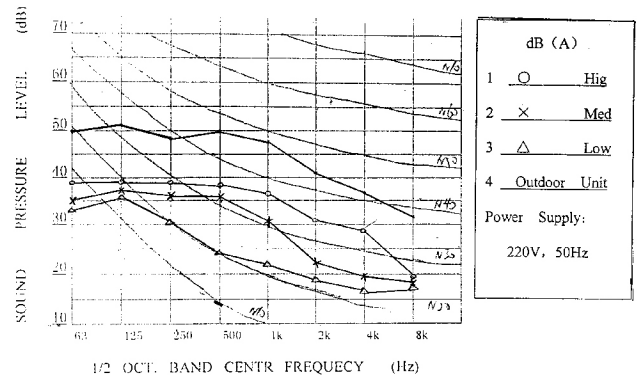

### HBU-36

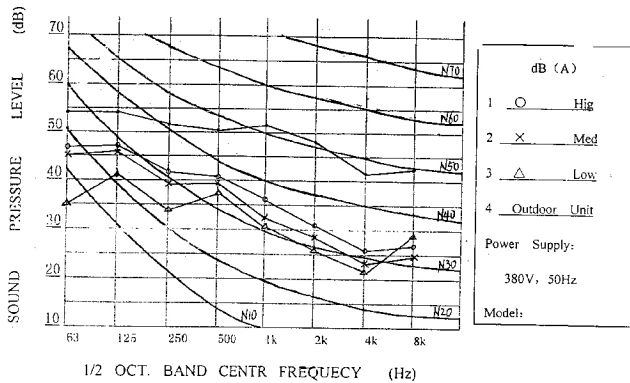

### HBU-42

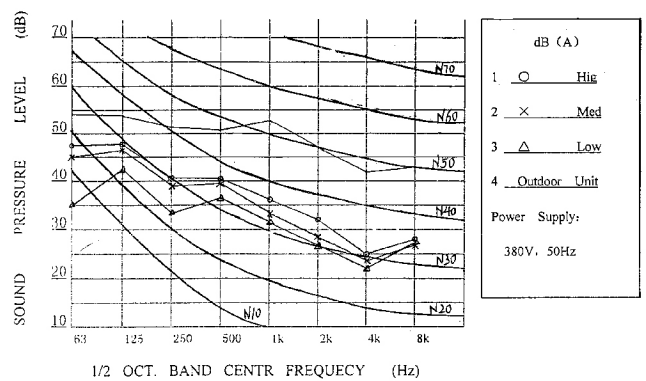

# 15 AIR VELOCITY DISTRIBUTION

Model: HBU-14H03 HBU-18HC03

a. Cooling / Air Velocity Distribution

Cooling

Blow angle:40

Air Velocity Distribution

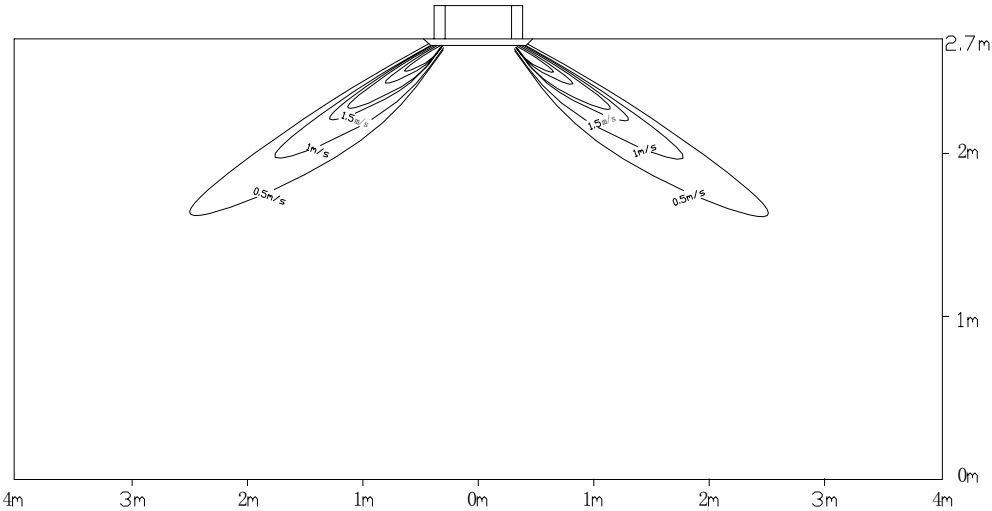

b. Cooling / Temperature Distribution

Cooling

Blow angle:40

Temperature Distribution

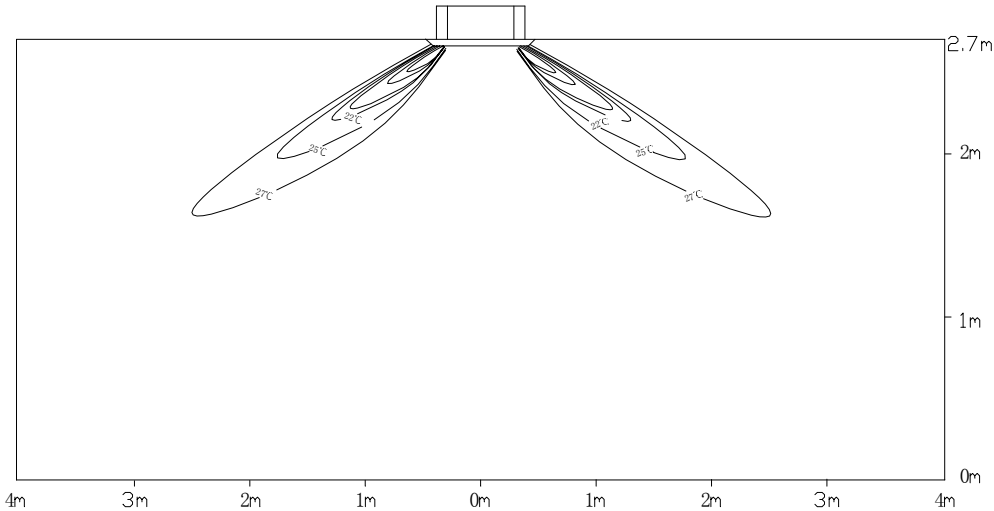

Model: HBU-24H03 HBU-28HD03

a. Cooling / Air Velocity Distribution

Cooling

Blow angle:40

Air Velocity Distribution

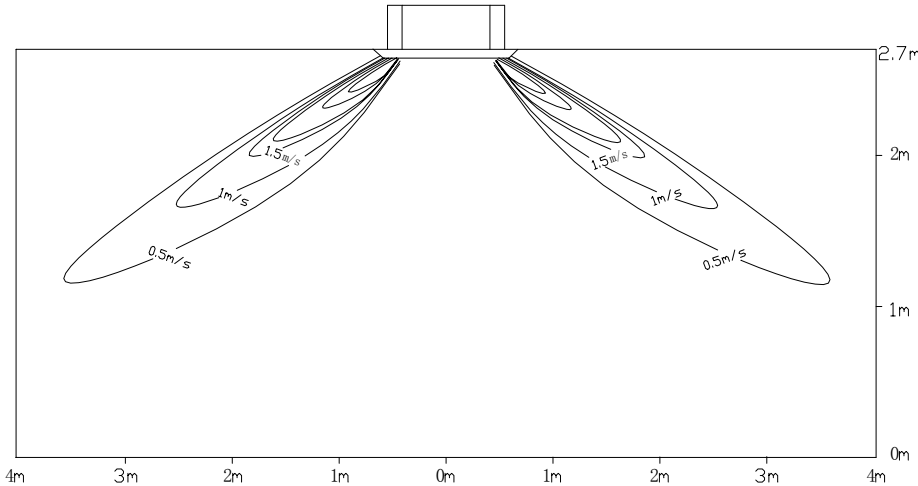

b. Cooling / Temperature Distribution

Cooling

Blow angle:40

Temperature Distribution

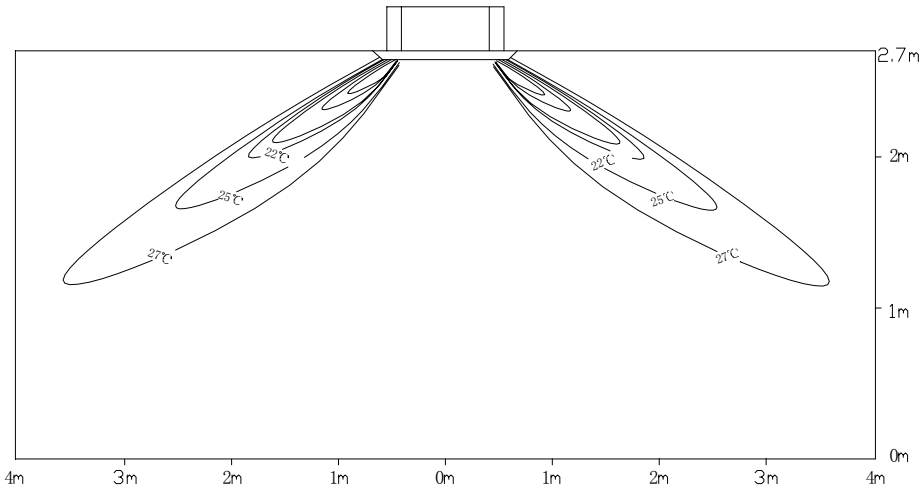



Model: HBU-36H03 HBU-42HD03

a. Cooling / Air Velocity Distribution

Cooling  
Blow angle:40  
Air Velocity Distribution

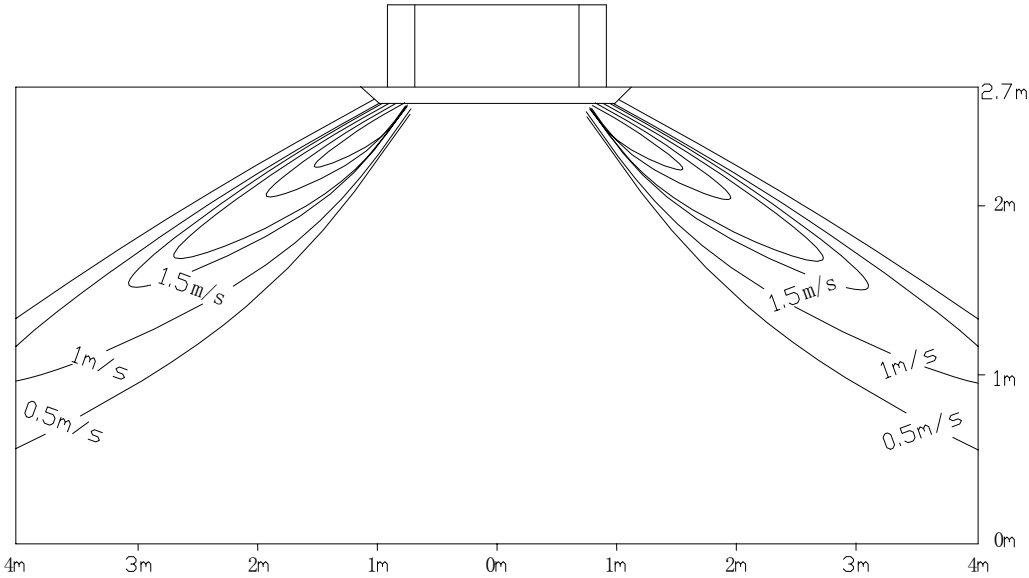

b. Cooling / Temperature Distribution

Cooling  
Blow angle:40  
Temperature Distribution

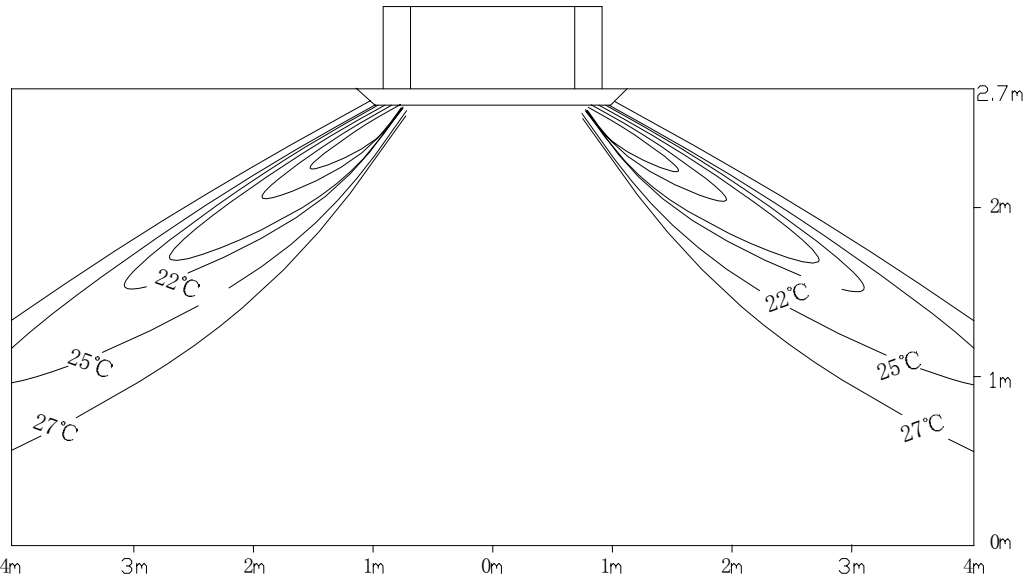

# Sincere Forever



Tel: 86-532-8938356

---

Web site: <http://www.haier.com>