



SIENBE37-704

R-410A

Service Manual

VRV[®] III

REYQ8-48PY1B

R-410 Heat Recovery 50HZ



VRV[®] III R-410A Heat Recovery 50Hz

1. Introduction	vi
1.1 Safety Cautions	vi
1.2 PREFACE	x

Part 1 General Information 1

1. Model Names of Indoor/Outdoor Units.....	2
2. External Appearance.....	3
2.1 Indoor Units	3
2.2 Outdoor Units	4
3. Combination of Outdoor Units.....	5
4. Model Selection.....	6

Part 2 Specifications 9

1. Specifications	10
1.1 Outdoor Units	10
1.2 Indoor Units	21
1.3 BS Units	56

Part 3 Refrigerant Circuit 57

1. Refrigerant Circuit	58
1.1 REYQ8P, 10P, 12P	58
1.2 REYQ14P, 16P	60
1.3 REMQ8P (Multi 8HP)	62
1.4 REMQ10P, 12P (Multi 10, 12HP).....	64
1.5 REMQ14P, 16P (Multi 14, 16HP).....	66
1.6 BS Unit Functional Parts	68
1.7 Indoor Units	69
2. Functional Parts Layout	70
2.1 REYQ8P, 10P, 12P	70
2.2 REYQ14P, 16P	71
2.3 REMQ8P	72
2.4 REMQ10P, 12P.....	73
2.5 REMQ14P, 16P.....	74
3. Refrigerant Flow for Each Operation Mode.....	75

Part 4 Function..... 103

1. Function General.....	104
1.1 Symbol	104
1.2 Operation Mode.....	106
2. Basic Control.....	107
2.1 Normal Operation	107
2.2 Compressor PI Control.....	108

2.3	Electronic Expansion Valve PI Control.....	116
2.4	Step Control of Outdoor Unit Fans	116
2.5	Outdoor Unit Fan Control in Cooling Operation	117
2.6	Heat Exchanger Control	118
3.	Special Control.....	119
3.1	Startup Control	119
3.2	Large Capacity Start Up Control (Heating).....	121
3.3	Oil Return Operation	122
3.4	Defrost Operation	126
3.5	Pump-down Residual Operation	128
3.6	Standby	130
3.7	Stopping Operation	131
4.	Protection Control	132
4.1	High Pressure Protection Control.....	132
4.2	Low Pressure Protection Control.....	134
4.3	Discharge Pipe Protection Control	136
4.4	Inverter Protection Control	137
4.5	STD Compressor Overload Protection.....	139
5.	Other Control.....	140
5.1	Backup Operation.....	140
5.2	Demand Operation	140
5.3	Heating Operation Prohibition	140
6.	Outline of Control (Indoor Unit)	141
6.1	Operation Flow Chart	141
6.2	Thermostat Control.....	143
6.3	Drain Pump Control.....	147
6.4	Control of Electronic Expansion Valve	149
6.5	Freeze Prevention	150
6.6	Heater Control (Optional PC Board KRP1B...is required.).....	151
6.7	List of Swing Flap Operations	152
6.8	Hot Start Control (In Heating Operation Only).....	153
6.9	Louver Control for Preventing Ceiling Dirt.....	154

Part 5 Test Operation 155

1.	Test Operation	156
1.1	Installation Process	156
1.2	Procedure and Outline	157
1.3	Operation when Power is Turned On	200
2.	Outdoor Unit PC Board Layout	201
3.	Field Setting	202
3.1	Field Setting from Remote Control	202
3.2	Field Setting from Outdoor Unit.....	215

Part 6 Troubleshooting	245
1. Symptom-based Troubleshooting	248
2. Troubleshooting by Remote Control	251
2.1 The INSPECTION / TEST Button.....	251
2.2 Self-diagnosis by Wired Remote Control	252
2.3 Self-diagnosis by Infrared Remote Control	253
2.4 Inspection Mode	256
2.5 Remote Control Service Mode	257
2.6 Test Run Mode.....	259
2.7 Remote Control Self-Diagnosis Function	259
3. Troubleshooting by Indication on the Remote Control	266
3.1 "R0" Indoor Unit: Error of External Protection Device	266
3.2 "R1" Indoor Unit: PC Board Defect.....	267
3.3 "R3" Indoor Unit: Malfunction of Drain Level Control System (S1L)	268
3.4 "R5" Indoor Unit: Fan Motor (M1F) Lock, Overload.....	270
"R5" Indoor Unit: Malfunction of Indoor Unit Fan Motor.....	272
"R5" Indoor Unit: Overload / Overcurrent /	
Lock of Indoor Unit Fan Motor	273
3.5 "R7" Indoor Unit: Malfunction of Swing Flap Motor (M1S).....	274
3.6 "R9" Electronic Expansion Valve Malfunction / Dust Clogging	276
"R9" Indoor Unit: Malfunction of Electronic Expansion Valve Coil.....	278
3.7 "RF" Indoor Unit: Drain Level above Limit.....	280
3.8 "RJ" Indoor Unit: Malfunction of Capacity Determination Device	281
3.9 "LY" Indoor Unit: Malfunction of Thermistor (R2T) for	
Heat Exchanger.....	282
3.10 "L5" Indoor Unit: Malfunction of Thermistor (R3T) for Gas Pipes.....	283
3.11 "L9" Indoor Unit: Malfunction of Thermistor (R1T) for Suction Air.....	284
3.12 "LJ" Indoor Unit: Malfunction of Thermostat Sensor	
in Remote Control	285
3.13 "E1" Outdoor Unit: PC Board Defect	286
3.14 "E3" Outdoor Unit: Actuation of High Pressure Switch	287
3.15 "E4" Outdoor Unit: Actuation of Low Pressure Sensor	289
3.16 "E5" Outdoor Unit: Inverter Compressor Motor Lock.....	291
3.17 "E6" Outdoor Unit: STD Compressor Motor Overcurrent/Lock.....	293
3.18 "E7" Outdoor Unit: Malfunction of Outdoor Unit Fan Motor	294
3.19 "E9" Outdoor Unit: Malfunction of Moving Part of Electronic Expansion	
Valve (Y1E~Y5E)	297
3.20 "F3" Outdoor Unit: Abnormal Discharge Pipe Temperature	299
3.21 "F5" Outdoor Unit: Refrigerant Overcharged.....	301
3.22 "F9" Outdoor Unit : Malfunction of	
BS Unit Electronic Expansion Valve.....	302
3.23 "H1" Outdoor Unit: Abnormal Outdoor Fan Motor Signal.....	304
3.24 "H9" Outdoor Unit: Malfunction of Thermistor (R1T) for Outdoor Air.....	306
3.25 "J2" Outdoor Unit: Current Sensor Malfunction	307
3.26 "J3" Outdoor Unit: Malfunction of Discharge Pipe Thermistor	
(R31T, R32T, R33T).....	308
3.27 "J4" Outdoor Unit: Malfunction of Temperature Sensor for	
Heat Exchanger Gas (R2T or R11T).....	309
3.28 "J5" Outdoor Unit: Malfunction of Thermistor (R8T or R10T) for	
Suction Pipe	310

3.29	“J5” Outdoor Unit: Malfunction of Thermistor (R4T or R12T) for Outdoor Unit Heat Exchanger	311
3.30	“J7” Outdoor Unit: Malfunction of Liquid Pipe Thermistor 1 (R6T, R9T or R14T)	312
3.31	“J8” Outdoor Unit: Malfunction of Liquid Pipe Thermistor 2 (R7T or R15T)	313
3.32	“J9” Outdoor Unit: Malfunction of Subcooling Heat Exchanger Gas Pipe Thermistor (R5T or R13T)	314
3.33	“JR” Outdoor Unit: Malfunction of High Pressure Sensor.....	315
3.34	“JC” Outdoor Unit: Malfunction of Low Pressure Sensor.....	317
3.35	“L1” Outdoor Unit: Defective Inverter PC Board	319
3.36	“L4” Outdoor Unit: Malfunction of Inverter Radiating Fin Temperature Rise.....	321
3.37	“L5” Outdoor Unit: Momentary Overcurrent of Inverter Compressor.....	324
3.38	“LB” Outdoor Unit: Momentary Overcurrent of Inverter Compressor.....	326
3.39	“L9” Outdoor Unit: Inverter Compressor Starting Failure	328
3.40	“LC” Outdoor Unit: Malfunction of Transmission between Inverter and Control PC Board	331
3.41	“P1” Outdoor Unit: Inverter Over-Ripple Protection	334
3.42	“P4” Outdoor Unit: Malfunction of Inverter Radiating Fin Temperature Rise Sensor	336
3.43	“PJ” Outdoor Unit: Faulty Field Setting after Replacing Main PC Board or Faulty Combination of PC Board.....	338
3.44	“UD” Outdoor Unit: Gas Shortage Alert	340
3.45	“U1” Reverse Phase, Open Phase.....	342
3.46	“U2” Outdoor Unit: Power Supply Insufficient or Instantaneous Failure	343
3.47	“U3” Outdoor Unit: Check Operation not Executed	346
3.48	“U4” Malfunction of Transmission between Indoor Units.....	347
3.49	“U5” Indoor Unit: Malfunction of Transmission between Remote Control and Indoor Unit.....	350
3.50	“U7” Outdoor Unit: Transmission Failure (Across Outdoor Units)	351
3.51	“UB” Indoor Unit: Malfunction of Transmission between Main and Sub Remote Controls	357
3.52	“U9” Indoor Unit: Malfunction of Transmission between Indoor and Outdoor Units in the Same System	358
3.53	“UR” Improper Combination of Indoor and Outdoor Units, Indoor Units and Remote Control.....	359
3.54	“UC” Address Duplication of Centralized Controller	365
3.55	“UE” Malfunction of Transmission between Centralized Controller and Indoor Unit.....	366
3.56	“UF” System is not Set yet.....	369
3.57	“UH” Malfunction of System, Refrigerant System Address Undefined	370
4.	Troubleshooting (OP: Central Remote Control)	372
4.1	“M1” PC Board Defect	372
4.2	“M8” Malfunction of Transmission between Optional Controllers for Centralized Control.....	373
4.3	“MR” Improper Combination of Optional Controllers for Centralized Control.....	374

- 4.4 “ μC ” Address Duplication, Improper Setting376
- 5. Troubleshooting (OP: Unified ON/OFF Controller)377
 - 5.1 Operation Lamp Blinks377
 - 5.2 Display “Under Centralized Control” Blinks
(Repeats Single Blink).....379
 - 5.3 Display “Under Centralized Control” Blinks
(Repeats Double Blink)382

Part 7 Appendix..... 397

- 1. Piping Diagrams398
 - 1.1 Outdoor Unit398
 - 1.2 Indoor Unit.....403
 - 1.3 BS Unit409
- 2. Wiring Diagrams for Reference410
 - 2.1 Outdoor Unit410
 - 2.2 Field Wiring415
 - 2.3 Indoor Unit.....418
 - 2.4 BS Unit434
- 3. List of Electrical and Functional Parts435
 - 3.1 Outdoor Unit435
 - 3.2 Indoor Side439
- 4. Option List445
 - 4.1 Option List of Controllers445
 - 4.2 Option Lists (Outdoor Unit).....447
- 5. Piping Installation Point448
 - 5.1 Piping Installation Point448
 - 5.2 The Example of a Wrong Pattern449
- 6. Example of connection (R-410A Type)451
- 7. Thermistor Resistance / Temperature Characteristics455
- 8. Pressure Sensor457
- 9. Method of Checking the Inverter’s Power Transistors and Diode Modules458
 - 9.1 Method of Checking the Inverter’s Power Transistors and Diode Modules458

Part 8 Precautions for New Refrigerant (R-410A) 461

- 1. Precautions for New Refrigerant (R-410A)462
 - 1.1 Outline462
 - 1.2 Refrigerant Cylinders.....464
 - 1.3 Service Tools.....465





Index i

Drawings & Flow Charts v







1. Introduction







1.1 Safety Cautions

Cautions and Warnings

- Be sure to read the following safety cautions before conducting repair work.
- The caution items are classified into “ **Warning**” and “ **Caution**”. The “ **Warning**” items are especially important since they can lead to death or serious injury if they are not followed closely. The “ **Caution**” items can also lead to serious accidents under some conditions if they are not followed. Therefore, be sure to observe all the safety caution items described below.
- About the pictograms
 - △ This symbol indicates an item for which caution must be exercised.
The pictogram shows the item to which attention must be paid.
 - This symbol indicates a prohibited action.
The prohibited item or action is shown inside or near the symbol.
 - This symbol indicates an action that must be taken, or an instruction.
The instruction is shown inside or near the symbol.
- After the repair work is complete, be sure to conduct a test operation to ensure that the equipment operates normally, and explain the cautions for operating the product to the customer



1.1.1 Caution in Repair



 Warning	
<p>Be sure to disconnect the power cable plug from the plug socket before disassembling the equipment for a repair. Working on the equipment that is connected to a power supply can cause an electrical shock. If it is necessary to supply power to the equipment to conduct the repair or inspecting the circuits, do not touch any electrically charged sections of the equipment.</p>	
<p>If the refrigerant gas discharges during the repair work, do not touch the discharging refrigerant gas. The refrigerant gas can cause frostbite.</p>	
<p>When disconnecting the suction or discharge pipe of the compressor at the welded section, release the refrigerant gas completely at a well-ventilated place first. If there is a gas remaining inside the compressor, the refrigerant gas or refrigerating machine oil discharges when the pipe is disconnected, and it can cause injury.</p>	
<p>If the refrigerant gas leaks during the repair work, ventilate the area. The refrigerant gas can generate toxic gases when it contacts flames.</p>	
<p>The step-up capacitor supplies high-voltage electricity to the electrical components of the outdoor unit. Be sure to discharge the capacitor completely before conducting repair work. A charged capacitor can cause an electrical shock.</p>	
<p>Do not start or stop the air conditioner operation by plugging or unplugging the power cable plug. Plugging or unplugging the power cable plug to operate the equipment can cause an electrical shock or fire.</p>	

 Caution	
Do not repair the electrical components with wet hands. Working on the equipment with wet hands can cause an electrical shock.	
Do not clean the air conditioner by splashing water. Washing the unit with water can cause an electrical shock.	
Be sure to provide the grounding when repairing the equipment in a humid or wet place, to avoid electrical shocks.	
Be sure to turn off the power switch and unplug the power cable when cleaning the equipment. The internal fan rotates at a high speed, and cause injury.	
Do not tilt the unit when removing it. The water inside the unit can spill and wet the furniture and floor.	
Be sure to check that the refrigerating cycle section has cooled down sufficiently before conducting repair work. Working on the unit when the refrigerating cycle section is hot can cause burns.	
Use the welder in a well-ventilated place. Using the welder in an enclosed room can cause oxygen deficiency.	





1.1.2 Cautions Regarding Products after Repair



 Warning	
Be sure to use parts listed in the service parts list of the applicable model and appropriate tools to conduct repair work. Never attempt to modify the equipment. The use of inappropriate parts or tools can cause an electrical shock, excessive heat generation or fire.	
When relocating the equipment, make sure that the new installation site has sufficient strength to withstand the weight of the equipment. If the installation site does not have sufficient strength and if the installation work is not conducted securely, the equipment can fall and cause injury.	
Be sure to install the product correctly by using the provided standard installation frame. Incorrect use of the installation frame and improper installation can cause the equipment to fall, resulting in injury.	For integral units only
Be sure to install the product securely in the installation frame mounted on a window frame. If the unit is not securely mounted, it can fall and cause injury.	For integral units only
Be sure to use an exclusive power circuit for the equipment, and follow the technical standards related to the electrical equipment, the internal wiring regulations and the instruction manual for installation when conducting electrical work. Insufficient power circuit capacity and improper electrical work can cause an electrical shock or fire.	

 Warning	
Be sure to use the specified cable to connect between the indoor and outdoor units. Make the connections securely and route the cable properly so that there is no force pulling the cable at the connection terminals. Improper connections can cause excessive heat generation or fire.	
When connecting the cable between the indoor and outdoor units, make sure that the terminal cover does not lift off or dismount because of the cable. If the cover is not mounted properly, the terminal connection section can cause an electrical shock, excessive heat generation or fire.	
Do not damage or modify the power cable. Damaged or modified power cable can cause an electrical shock or fire. Placing heavy items on the power cable, and heating or pulling the power cable can damage the cable.	
Do not mix air or gas other than the specified refrigerant (R-410A) in the refrigerant system. If air enters the refrigerating system, an excessively high pressure results, causing equipment damage and injury.	
If the refrigerant gas leaks, be sure to locate the leak and repair it before charging the refrigerant. After charging refrigerant, make sure that there is no refrigerant leak. If the leak cannot be located and the repair work must be stopped, be sure to perform pump-down and close the service valve, to prevent the refrigerant gas from leaking into the room. The refrigerant gas itself is harmless, but it can generate toxic gases when it contacts flames, such as fan and other heaters, stoves and ranges.	
When replacing the coin battery in the remote control, be sure to disposed of the old battery to prevent children from swallowing it. If a child swallows the coin battery, see a doctor immediately.	

 Caution	
Installation of a leakage breaker is necessary in some cases depending on the conditions of the installation site, to prevent electrical shocks.	
Do not install the equipment in a place where there is a possibility of combustible gas leaks. If a combustible gas leaks and remains around the unit, it can cause a fire.	
Be sure to install the packing and seal on the installation frame properly. If the packing and seal are not installed properly, water can enter the room and wet the furniture and floor.	For integral units only

1.1.3 Inspection after Repair





 Warning	
Check to make sure that the power cable plug is not dirty or loose, then insert the plug into a power outlet all the way. If the plug has dust or loose connection, it can cause an electrical shock or fire.	
If the power cable and lead wires have scratches or deteriorated, be sure to replace them. Damaged cable and wires can cause an electrical shock, excessive heat generation or fire.	
Do not use a joined power cable or extension cable, or share the same power outlet with other electrical appliances, since it can cause an electrical shock, excessive heat generation or fire.	

 Caution	
Check to see if the parts and wires are mounted and connected properly, and if the connections at the soldered or crimped terminals are secure. Improper installation and connections can cause excessive heat generation, fire or an electrical shock.	
If the installation platform or frame has corroded, replace it. Corroded installation platform or frame can cause the unit to fall, resulting in injury.	
Check the grounding, and repair it if the equipment is not properly grounded. Improper grounding can cause an electrical shock.	
Be sure to measure the insulation resistance after the repair, and make sure that the resistance is 1 Mohm or higher. Faulty insulation can cause an electrical shock.	
Be sure to check the drainage of the indoor unit after the repair. Faulty drainage can cause the water to enter the room and wet the furniture and floor.	

1.1.4 Using Icons

Icons are used to attract the attention of the reader to specific information. The meaning of each icon is described in the table below:

1.1.5 Using Icons List

Icon	Type of Information	Description
 Note:	Note	A “note” provides information that is not indispensable, but may nevertheless be valuable to the reader, such as tips and tricks.
 Caution	Caution	A “caution” is used when there is danger that the reader, through incorrect manipulation, may damage equipment, lose data, get an unexpected result or has to restart (part of) a procedure.
 Warning	Warning	A “warning” is used when there is danger of personal injury.
	Reference	A “reference” guides the reader to other places in this binder or in this manual, where he/she will find additional information on a specific topic.

1.2 PREFACE

Thank you for your continued patronage of Daikin products.

This is the new service manual for Daikin's Year 2007 VRVIII series Heat Recovery System. Daikin offers a wide range of models to respond to building and office air conditioning needs. We are confident that customers will be able to find the models that best suit their needs.

This service manual contains information regarding the servicing of VRVIII series R-410A Heat Recovery System.

Jan., 2008

After Sales Service Division

Part 1

General Information

1. Model Names of Indoor/Outdoor Units.....	2
2. External Appearance.....	3
2.1 Indoor Units.....	3
2.2 Outdoor Units.....	4
3. Combination of Outdoor Units.....	5
4. Model Selection.....	6

1. Model Names of Indoor/Outdoor Units

Indoor Units

Type		Model Name											Power Supply
Roundflow Ceiling Mounted Cassette	FXFQ	20P	25P	32P	40P	50P	63P	80P	100P	125P	—	—	VE
600×600 4-Way Blow Ceiling Mounted Cassette	FXZQ	20M	25M	32M	40M	50M	—	—	—	—	—	—	V1
2-Way Blow Ceiling Mounted Cassette	FXCQ	20M	25M	32M	40M	50M	63M	80M	—	125M	—	—	V3
Ceiling Mounted Corner Cassette	FXKQ	—	25MA	32MA	40MA	—	63MA	—	—	—	—	—	VE
Slim Concealed Ceiling Unit	FXDQ-PVE	20P	25P	32P	—	—	—	—	—	—	—	—	
	FXDQ-NAVE	—	—	—	40NA	50NA	63NA	—	—	—	—	—	
Concealed Ceiling Unit (Small)	FXDQ	20M	25M	—	—	—	—	—	—	—	—	—	V3
Concealed Ceiling Unit	FXSQ	20M	25M	32M	40M	50M	63M	80M	100M	125M	—	—	VE
Concealed Ceiling Unit (Large)	FXMQ	—	—	—	40MA	50MA	63MA	80MA	100MA	125MA	200MA	250MA	
Ceiling Suspended Unit	FXHQ	—	—	32MA	—	—	63MA	—	100MA	—	—	—	VE
Wall Mounted Unit	FXAQ	20MA	25MA	32MA	40MA	50MA	63MA	—	—	—	—	—	
Floor Standing Unit	FXLQ	20MA	25MA	32MA	40MA	50MA	63MA	—	—	—	—	—	
Concealed Floor Standing Unit	FXNQ	20MA	25MA	32MA	40MA	50MA	63MA	—	—	—	—	—	
4-way blow ceiling suspended unit	FXUQ	—	—	—	—	—	—	71MA	100MA	125MA	—	—	V1
Connection Unit for FXUQ	BEVQ	—	—	—	—	—	—	71MA	100MA	125MA	—	—	VE

Note: FXDQ has following 2 Series, as show below.

FXDQ-P, NAVE: with Drain Pump

BEV unit is required for FXUQ only.

MA, NA: RoHS Directive models; Specifications, Dimensions and other functions are not changed compared with M, N type.

BS Units

Type	Model Name			Power Supply	
Heat Recovery Series	BSVQ	100P	160P	250P	V1

Outdoor Units

Normal Series

Series	Model Name										Power Supply
Heat Recovery	REYQ	8P	10P	12P	14P	16P	18P	20P	22P	24P	Y1
		26P	28P	30P	32P	34P	36P	38P	40P	42P	
		44P	46P	48P							

Power Supply: VE : 1φ, 220~240V, 50Hz, 1φ, 220V, 60Hz

V1 : 1φ, 220~240V, 50Hz

V3 : 1φ, 230V, 50Hz







Y1 : 3φ, 380~415V, 50Hz

2. External Appearance

2.1 Indoor Units

<p>Roundflow Ceiling Mounted Cassette</p> <p>FXFQ20P FXFQ25P FXFQ32P FXFQ40P FXFQ50P FXFQ63P FXFQ80P FXFQ100P FXFQ125P</p> 	<p>Concealed Ceiling Unit (Large)</p> <p>FXMQ40MA FXMQ50MA FXMQ63MA FXMQ80MA FXMQ100MA FXMQ125MA FXMQ200MA FXMQ250MA</p>  <p>FXMQ40~125M FXMQ200 · 250M</p>
<p>600×600 4-Way Blow Ceiling Mounted Cassette</p> <p>FXZQ20M FXZQ25M FXZQ32M FXZQ40M FXZQ50M</p> 	<p>Ceiling Suspended Unit</p> <p>FXHQ32MA FXHQ63MA FXHQ100MA</p> 
<p>2-Way Blow Ceiling Mounted Cassette</p> <p>FXCQ20M FXCQ25M FXCQ32M FXCQ40M FXCQ50M FXCQ63M FXCQ80M FXCQ125M</p> 	<p>Wall Mounted Unit</p> <p>FXAQ20MA FXAQ25MA FXAQ32MA FXAQ40MA FXAQ50MA FXAQ63MA</p> 
<p>Ceiling Mounted Corner Cassette</p> <p>FXKQ25MA FXKQ32MA FXKQ40MA FXKQ63MA</p> 	<p>Floor Standing Unit</p> <p>FXLQ20MA FXLQ25MA FXLQ32MA FXLQ40MA FXLQ50MA FXLQ63MA</p> 
<p>Slim Concealed Ceiling Unit</p> <p>FXDQ20P FXDQ40NA FXDQ25P FXDQ50NA FXDQ32P FXDQ63NA with Drain Pump (VE)</p> 	<p>Concealed Floor Standing Unit</p> <p>FXNQ20MA FXNQ25MA FXNQ32MA FXNQ40MA FXNQ50MA FXNQ63MA</p> 
<p>Concealed Ceiling Unit (Small)</p> <p>FXDQ20M FXDQ25M</p> 	<p>BS Units</p> <p>BSVQ100P BSVQ160P BSVQ250P</p> 
<p>Concealed Ceiling Unit</p> <p>FXSQ20M FXSQ25M FXSQ32M FXSQ40M FXSQ50M FXSQ63M FXSQ80M FXSQ100M FXSQ125M</p> 	<p>4-way blow ceiling suspended unit (Connection Unit Series)</p> <p>FXUQ71MA + BEVQ71MA FXUQ100MA + BEVQ100MA FXUQ125MA + BEVQ125MA</p> <p>Connection Unit</p> 

2.2 Outdoor Units

REYQ8P, 10P, 12P, 14P, 16P		REYQ18P, 20P, 22P, 24P	
 <p>8, 10, 12, 14, 16 HP 22.4 ~ 40.0, 45.0 kW</p>		 <p>18, 20, 22, 24 HP 50.4 ~ 67.0 kW</p>	
REYQ26P, 28P	REYQ30P, 32P	REYQ34P, 36P, 38P, 40P	
 <p>26, 28 HP 73.0, 78.5 kW</p>	 <p>30, 32 HP 85.0, 90.0 kW</p>	 <p>34, 36, 38, 40 HP 95.4 ~ 112 kW</p>	
REYQ42P, 44P		REYQ46P, 48P	
 <p>42, 44 HP 118 ~ 124 kW</p>		 <p>46, 48 HP 130, 135 kW</p>	

3. Combination of Outdoor Units

Single Use

System Capacity	Number of units	Single Unit					Outdoor Unit Multi Connection Piping Kit (Option)
		8	10	12	14	16	
8HP	1	●					—
10HP	1		●				
12HP	1			●			
14HP	1				●		
16HP	1					●	

Multiple Use

System Capacity	Number of units	Multi Unit Module					Outdoor Unit Multi Connection Piping Kit (Option)
		8	10	12	14	16	
18HP	2	●	●				Heat Recovery: BHFP26P90
20HP	2	●		●			
22HP	2		●	●			
24HP	2			●●			
26HP	2		●			●	
28HP	2			●		●	
30HP	2				●	●	
32HP	2					●●	
34HP	3	●	●			●	Heat Recovery: BHFP26P136
36HP	3	●		●		●	
38HP	3		●	●		●	
40HP	3			●●		●	
42HP	3		●			●●	
44HP	3			●		●●	
46HP	3				●	●●	
48HP	3					●●●	



Note: For multiple connection of 18HP system or more, an optional Daikin Outdoor Unit Multi Connection Piping Kit is required.

4. Model Selection

VRV III Heat Recovery Series

Connectable indoor units number and capacity

Normal Series

HP	8HP	10HP	12HP	14HP	16HP	18HP	20HP
System name	REYQ8P	REYQ10P	REYQ12P	REYQ14P	REYQ16P	REYQ18P	REYQ20P
Outdoor unit 1	REYQ8P	REYQ10P	REYQ12P	REYQ14P	REYQ16P	REMQ8P	REMQ8P
Outdoor unit 2	–	–	–	–	–	REMQ10P	REMQ12P
Outdoor unit 3	–	–	–	–	–	–	–
Total number of connectable indoor units	13	16	19	22	26	29	32
Total capacity of connectable indoor units (kW)	10.0~26.0	12.5~32.5	15.0~39.0	17.5~45.5	20.0~52.0	22.5~58.5	25.0~65.0

HP	22HP	24HP	26HP	28HP	30HP	32HP	34HP
System name	REYQ22P	REYQ24P	REYQ26P	REYQ28P	REYQ30P	REYQ32P	REYQ34P
Outdoor unit 1	REMQ10P	REMQ12P	REMQ10P	REMQ12P	REMQ14P	REMQ16P	REMQ8P
Outdoor unit 2	REMQ12P	REMQ12P	REMQ16P	REMQ16P	REMQ16P	REMQ16P	REMQ10P
Outdoor unit 3	–	–	–	–	–	–	REMQ16P
Total number of connectable indoor units	35	39	42	45	48	52	55
Total capacity of connectable indoor units (kW)	27.5~71.5	30.0~78.0	32.5~84.5	35.0~91.0	37.5~97.5	40.0~104.0	42.5~110.5

HP	36HP	38HP	40HP	42HP	44HP	46HP	48HP
System name	REYQ36P	REYQ38P	REYQ40P	REYQ42P	REYQ44P	REYQ46P	REYQ48P
Outdoor unit 1	REMQ8P	REMQ10P	REMQ12P	REMQ10P	REMQ12P	REMQ14P	REMQ16P
Outdoor unit 2	REMQ12P	REMQ12P	REMQ12P	REMQ16P	REMQ16P	REMQ16P	REMQ16P
Outdoor unit 3	REMQ16P	REMQ16P	REMQ16P	REMQ16P	REMQ16P	REMQ16P	REMQ16P
Total number of connectable indoor units	58	61	64				
Total capacity of connectable indoor units (kW)	45.0~117.0	47.5~123.5	50.0~130.0	52.5~136.5	55.0~143.0	57.5~149.5	60.0~156.0

Connectable Indoor Unit

Type		Model Name											Power Supply
Roundflow Ceiling Mounted Cassette	FXFQ	20P	25P	32P	40P	50P	63P	80P	100P	125P	—	—	VE
600×600 4-Way Blow Ceiling Mounted Cassette	FXZQ	20M	25M	32M	40M	50M	—	—	—	—	—	—	V1
2-Way Blow Ceiling Mounted Cassette	FXCQ	20M	25M	32M	40M	50M	63M	80M	—	125M	—	—	V3
Ceiling Mounted Corner Cassette	FXKQ	—	25MA	32MA	40MA	—	63MA	—	—	—	—	—	VE
Slim Concealed Ceiling Unit	FXDQ-PVE	20P	25P	32P	—	—	—	—	—	—	—	—	
	FXDQ-NAVE	—	—	—	40NA	50NA	63NA	—	—	—	—	—	
Concealed Ceiling Unit (Small)	FXDQ	20M	25M	—	—	—	—	—	—	—	—	—	V3
Concealed Ceiling Unit	FXSQ	20M	25M	32M	40M	50M	63M	80M	100M	125M	—	—	VE
Concealed Ceiling Unit (Large)	FXMQ	—	—	—	40MA	50MA	63MA	80MA	100MA	125MA	200MA	250MA	
Ceiling Suspended Unit	FXHQ	—	—	32MA	—	—	63MA	—	100MA	—	—	—	VE
Wall Mounted Unit	FXAQ	20MA	25MA	32MA	40MA	50MA	63MA	—	—	—	—	—	
Floor Standing Unit	FXLQ	20MA	25MA	32MA	40MA	50MA	63MA	—	—	—	—	—	
Concealed Floor Standing Unit	FXNQ	20MA	25MA	32MA	40MA	50MA	63MA	—	—	—	—	—	
4-way blow ceiling suspended unit	FXUQ	—	—	—	—	—	—	71MA	100MA	125MA	—	—	V1
Connection Unit for FXUQ	BEVQ	—	—	—	—	—	—	71MA	100MA	125MA	—	—	VE

Note: FXDQ has following 2 Series, as shown below.

FXDQ-P, NAVE: with Drain Pump

BEV unit is required for FXUQ only.

Indoor unit capacity

New refrigerant model code	P20 type	P25 type	P32 type	P40 type	P50 type	P63 type	P80 type	P100 type	P125 type	P200 type	P250 type
Selecting model capacity	2.2 kW	2.8 kW	3.5 kW	4.5 kW	5.6 kW	7.0 kW	9.0 kW	11.2 kW	14.0 kW	22.4 kW	28.0 kW
Equivalent output	0.8HP	1HP	1.25HP	1.6HP	2.0HP	2.5HP	3.2HP	4HP	5HP	8HP	10HP

Use the above tables to determine the capacities of indoor units to be connected. Make sure the total capacity of indoor units connected to each outdoor unit is within the specified value (kW).

- The total capacity of connected indoor units must be within a range of 50 to 130% of the rated capacity of the outdoor unit.
- In some models, it is not possible to connect the maximum number of connectable indoor units. Select models so the total capacity of connected indoor units conforms to the specification.

Differences from Conventional Models

Item	Differences		
	Object	New model (P Model)	Conventional model (M Model)
Compressor	Connection of equalizer oil pipe	<ul style="list-style-type: none"> ● NONE (No particular changes in terms of service) 	<ul style="list-style-type: none"> ● YES
Workability	Equalizer oil pipe for multi-outdoor-unit system	<ul style="list-style-type: none"> ● NONE 	<ul style="list-style-type: none"> ● YES
	Procedure for calculating refrigerant refilling quantity	<ul style="list-style-type: none"> ● Refilling quantity due to piping length + Adjustment quantity according to models of outdoor units 	<ul style="list-style-type: none"> ● Refilling quantity due to piping length - Adjustment quantity according to models of outdoor units
Optional accessories	Branch pipe for outdoor unit connection	<ul style="list-style-type: none"> ● Y branch Type: BHFP26P90/136 	<ul style="list-style-type: none"> ● T branch Type: BHFP26M90+BHFP22M90P BHFP26M135+BHFP22M135P

Part 2

Specifications

1. Specifications	10
1.1 Outdoor Units	10
1.2 Indoor Units	21
1.3 BS Units	56

1. Specifications

1.1 Outdoor Units

Heat Recovery 50Hz <REYQ-P>

Model Name		REYQ8P8Y1B		REYQ10P8Y1B		
★1 Cooling Capacity (19.5°CWB)	kcal / h	19,400		24,300		
	Btu / h	76,800		96,200		
	kW	22.5		28.2		
★2 Cooling Capacity (19.0°CWB)	kW	22.4		28.0		
★3 Heating Capacity	kcal / h	21,500		27,100		
	Btu / h	85,300		107,000		
	kW	25.0		31.5		
Casing Color	Y1 Type	Ivory White 5Y7.5/1		Ivory White 5Y7.5/1		
	Y1E Type	Light Camel 2.5Y6.5/1.5		Light Camel 2.5Y6.5/1.5		
Dimensions: (H×W×D)	mm	1680×1300×765		1680×1300×765		
Heat Exchanger		Cross Fin Coil		Cross Fin Coil		
Comp.	Type	Hermetically Sealed Scroll Type		Hermetically Sealed Scroll Type		
	Piston Displacement	m ³ /h	7.88+10.53		13.34+10.53	
	Number of Revolutions	r.p.m	3720, 2900		6300, 2900	
	Motor Output×Number of Units	kW	1.0+4.5		2.2+4.5	
	Starting Method		Soft Start		Soft Start	
Fan	Type	Propellor Fan		Propellor Fan		
	Motor Output	kW	0.35×2		0.35×2	
	Air Flow Rate	l/s	3,166		3,166	
		m ³ /min	190		190	
Drive		Direct Drive		Direct Drive		
Connecting Pipes	Liquid Pipe	φ9.5 C1220T (Brazing Connection)		φ9.5 C1220T (Brazing Connection)		
	Suction Gas Pipe	φ19.1 C1220T (Brazing Connection)		φ22.2 C1220T (Brazing Connection)		
	High and Low Pressure Gas Pipe	φ15.9 C1220T (Brazing Connection)		φ19.1 C1220T (Brazing Connection)		
	Pressure Equalizer Tube	—		—		
Mass (Weight)	kg	331		331		
Safety Devices		High Pressure Switch, Fan Driver Overload Protector, Over Current Relay, Inverter Overload Protector		High Pressure Switch, Fan Driver Overload Protector, Over Current Relay, Inverter Overload Protector		
Defrost Method		Deicer		Deicer		
Capacity Control	%	20~100		14~100		
Refrigerant	Refrigerant Name	R-410A		R-410A		
	Charge	kg	10.3		10.6	
	Control	Electronic Expansion Valve		Electronic Expansion Valve		
Refrigerator Oil		Refer to the nameplate of compressor		Refer to the nameplate of compressor		
Standard Accessories		Installation Manual, Operation Manual, Connection Pipes, Clamps		Installation Manual, Operation Manual, Connection Pipes, Clamps		
Drawing No.		4D057563B		4D057564B		

Notes:

- ★1 Indoor temp. : 27°CDB, 19.5°CWB / outdoor temp. : 35°CDB / Equivalent piping length : 7.5m, level difference : 0m.
- ★2 Indoor temp. : 27°CDB, 19.0°CWB / outdoor temp. : 35°CDB / Equivalent piping length : 7.5m, level difference : 0m.
- ★3 Indoor temp. : 20°CDB / outdoor temp. : 7°CDB, 6°CWB / Equivalent piping length : 7.5m, level difference : 0m.

Conversion Formulae
kcal/h=kW×860
Btu/h=kW×3412
cfm=m ³ /min×35.3

The Reference Number
 C~: Partly corrected drawings.
 J~: Original drawing is Japanese
 V~: Printing Convenience

Model Name		REYQ12P8Y1B	REYQ14P8Y1B	
★1 Cooling Capacity (19.5°CWB)	kcal / h	29,000	35,500	
	Btu / h	115,000	141,000	
	kW	33.7	41.3	
★2 Cooling Capacity (19.0°CWB)	kW	33.5	40.0	
★3 Heating Capacity	kcal / h	32,300	38,700	
	Btu / h	128,000	154,000	
	kW	37.5	45.0	
Casing Color	Y1 Type	Ivory White 5Y7.5/1	Ivory White 5Y7.5/1	
	Y1E Type	Light Camel 2.5Y6.5/1.5	Light Camel 2.5Y6.5/1.5	
Dimensions: (H×W×D)	mm	1680×1300×765	1680×1300×765	
Heat Exchanger		Cross Fin Coil	Cross Fin Coil	
Comp.	Type	Hermetically Sealed Scroll Type	Hermetically Sealed Scroll Type	
	Piston Displacement	m³/h	13.34+10.53	16.90+16.90
	Number of Revolutions	r.p.m	6300, 2900	7980, 7980
	Motor Output×Number of Units	kW	3.3+4.5	3.8+3.8
	Starting Method		Soft Start	Soft Start
Fan	Type	Propellor Fan	Propellor Fan	
	Motor Output	kW	0.35×2	0.75×2
	Air Flow Rate	l/s	3,500	3,916
		m³/min	210	235
Drive		Direct Drive	Direct Drive	
Connecting Pipes	Liquid Pipe	φ12.7 C1220T (Brazing Connection)	φ12.7 C1220T (Brazing Connection)	
	Suction Gas Pipe	φ28.6 C1220T (Brazing Connection)	φ28.6 C1220T (Brazing Connection)	
	High and Low Pressure Gas Pipe	φ19.1 C1220T (Brazing Connection)	φ22.2 C1220T (Brazing Connection)	
	Pressure Equalizer Tube	—	—	
Mass (Weight)	kg	331	339	
Safety Devices		High Pressure Switch, Fan Driver Overload Protector, Over Current Relay, Inverter Overload Protector	High Pressure Switch, Fan Driver Overload Protector, Over Current Relay, Inverter Overload Protector	
Defrost Method		Deicer	Deicer	
Capacity Control	%	14~100	10~100	
Refrigerant	Refrigerant Name	R-410A	R-410A	
	Charge	kg	10.8	11.1
	Control		Electronic Expansion Valve	Electronic Expansion Valve
Refrigerator Oil		Refer to the nameplate of compressor	Refer to the nameplate of compressor	
Standard Accessories		Installation Manual, Operation Manual, Connection Pipes, Clamps	Installation Manual, Operation Manual, Connection Pipes, Clamps	
Drawing No.		4D057565B	4D057566B	

Notes:

- ★1 Indoor temp. : 27°CDB, 19.5°CWB / outdoor temp. : 35°CDB / Equivalent piping length : 7.5m, level difference : 0m.
- ★2 Indoor temp. : 27°CDB, 19.0°CWB / outdoor temp. : 35°CDB / Equivalent piping length : 7.5m, level difference : 0m.
- ★3 Indoor temp. : 20°CDB / outdoor temp. : 7°CDB, 6°CWB / Equivalent piping length : 7.5m, level difference : 0m.

Conversion Formulae
kcal/h=kW×860
Btu/h=kW×3412
cfm=m³/min×35.3

Model Name		REYQ16P8Y1B	
★1 Cooling Capacity (19.5°CWB)	kcal / h	40,000	
	Btu / h	159,000	
	kW	46.5	
★2 Cooling Capacity (19.0°CWB)	kW	45.0	
★3 Heating Capacity	kcal / h	43,000	
	Btu / h	171,000	
	kW	50.0	
Casing Color	Y1 Type	Ivory White 5Y7.5/1	
	Y1E Type	Light Camel 2.5Y6.5/1.5	
Dimensions: (H×W×D)	mm	1680×1300×765	
Heat Exchanger		Cross Fin Coil	
Comp.	Type	Hermetically Sealed Scroll Type	
	Piston Displacement	m³/h	16.90+16.90
	Number of Revolutions	r.p.m	7980, 7980
	Motor Output×Number of Units	kW	4.4+4.4
	Starting Method	Soft Start	
Fan	Type	Propellor Fan	
	Motor Output	kW	0.75×2
	Air Flow Rate	l/s	4,000
		m³/min	240
	Drive	Direct Drive	
Connecting Pipes	Liquid Pipe	φ12.7 C1220T (Brazing Connection)	
	Suction Gas Pipe	φ28.6 C1220T (Brazing Connection)	
	High and Low Pressure Gas Pipe	φ22.2 C1220T (Brazing Connection)	
	Pressure Equalizer Tube	—	
Mass (Weight)	kg	339	
Safety Devices		High Pressure Switch, Fan Driver Overload Protector, Over Current Relay, Inverter Overload Protector	
Defrost Method		Deicer	
Capacity Control	%	10~100	
Refrigerant	Refrigerant Name	R-410A	
	Charge	kg	11.1
	Control	Electronic Expansion Valve	
Refrigerator Oil		Refer to the nameplate of compressor	
Standard Accessories		Installation Manual, Operation Manual, Connection Pipes, Clamps	
Drawing No.		4D057567B	

Notes:

- ★1 Indoor temp. : 27°CDB, 19.5°CWB / outdoor temp. : 35°CDB / Equivalent piping length : 7.5m, level difference : 0m.
- ★2 Indoor temp. : 27°CDB, 19.0°CWB / outdoor temp. : 35°CDB / Equivalent piping length : 7.5m, level difference : 0m.
- ★3 Indoor temp. : 20°CDB / outdoor temp. : 7°CDB, 6°CWB / Equivalent piping length : 7.5m, level difference : 0m.

Conversion Formulae
kcal/h=kW×860
Btu/h=kW×3412
cfm=m³/min×35.3

Model Name (Combination Unit)		REYQ18P8Y1B		REYQ20P8Y1B		
Model Name (Independent Unit)		REMQ8P8Y1B+REMQ10P8Y1B		REMQ8P8Y1B+REMQ12P8Y1B		
★1 Cooling Capacity (19.5°CWB)	kcal / h	43,600		48,300		
	Btu / h	173,000		192,000		
	kW	50.7		56.2		
★2 Cooling Capacity (19.0°CWB)	kW	50.4		55.9		
★3 Heating Capacity	kcal / h	48,600		53,800		
	Btu / h	193,000		213,000		
	kW	56.5		62.5		
Casing Color	Y1 Type	Ivory White 5Y7.5/1		Ivory White 5Y7.5/1		
	Y1E Type	Light Camel 2.5Y6.5/1.5		Light Camel 2.5Y6.5/1.5		
Dimensions: (H×W×D)	mm	1680×930×765+1680×930×765		1680×930×765+1680×930×765		
Heat Exchanger		Cross fin coil		Cross fin coil		
Comp.	Type	Hermetically sealed scroll type		Hermetically sealed scroll type		
	Piston Displacement	m ³ /h	(13.34+10.53)+16.90		(13.34+10.53)+16.90	
	Number of Revolutions	r.p.m	(6300, 2900), 7980		(6300, 2900), 7980	
	Motor Output×Number of Units	kW	(2.2+4.5)×1+4.7×1		(3.5+4.5)×1+4.7×1	
	Starting Method		Soft start		Soft start	
Fan	Type	Propellor fan		Propellor fan		
	Motor Output	kW	(0.75×1)+(0.75×1)		(0.75×1)+(0.75×1)	
	Air Flow Rate	l/s	3,000+3,083		3,000+3,333	
		m ³ /min	180+185		180+200	
Drive		Direct drive		Direct drive		
Connecting Pipes	Liquid Pipe	φ15.9 C1220T (Brazing connection)		φ15.9 C1220T (Brazing connection)		
	Suction Gas Pipe	φ28.6 C1220T (Brazing connection)		φ28.6 C1220T (Brazing connection)		
	High and Low Pressure Gas Pipe	φ22.2 C1220T (Brazing connection)		φ28.6 C1220T (Brazing connection)		
	Pressure Equalizer Tube	φ19.1 C1220T (Brazing connection)		φ19.1 C1220T (Brazing connection)		
Mass (Weight)	kg	204+254		204+254		
Safety Devices		High pressure switch, fan driver overload protector, overcurrent relay, inverter overload protector		High pressure switch, fan driver overload protector, overcurrent relay, inverter overload protector		
Defrost Method		Deicer		Deicer		
Capacity Control	%	9~100		7~100		
Refrigerant	Refrigerant Name		R-410A		R-410A	
	Charge	kg	8.2+9.0		8.2+9.1	
	Control		Electronic expansion valve		Electronic expansion valve	
Refrigerator Oil		Refer to the nameplate of compressor		Refer to the nameplate of compressor		
Standard Accessories		Installation manual, Operation manual, Connection pipes, Cramps		Installation manual, Operation manual, Connection pipes, Cramps		
Drawing No.		4D057568A		4D057569A		

Notes:

- ★1 Indoor temp. : 27°CDB, 19.5°CWB / outdoor temp. : 35°CDB / Equivalent piping length : 7.5m, level difference : 0m.
- ★2 Indoor temp. : 27°CDB, 19.0°CWB / outdoor temp. : 35°CDB / Equivalent piping length : 7.5m, level difference : 0m.
- ★3 Indoor temp. : 20°CDB / outdoor temp. : 7°CDB, 6°CWB / Equivalent piping length : 7.5m, level difference : 0m.

Conversion Formulae
kcal/h=kW×860
Btu/h=kW×3412
cfm=m ³ /min×35.3

Model Name (Combination Unit)		REYQ22P8Y1B		REYQ24P8Y1B		
Model Name (Independent Unit)		REMQ10P8Y1B+REMQ12P8Y1B		REMQ12P8Y1B+REMQ12P8Y1B		
★1 Cooling Capacity (19.5°CWB)	kcal / h	53,200		58,000		
	Btu / h	211,000		230,000		
	kW	61.9		67.4		
★2 Cooling Capacity (19.0°CWB)	kW	61.5		67.0		
★3 Heating Capacity	kcal / h	59,300		64,500		
	Btu / h	235,000		256,000		
	kW	69.0		75.0		
Casing Color	Y1 Type	Ivory White 5Y7.5/1		Ivory White 5Y7.5/1		
	Y1E Type	Light Camel 2.5Y6.5/1.5		Light Camel 2.5Y6.5/1.5		
Dimensions: (H×W×D)	mm	1680×930×765+1680×930×765		1680×930×765+1680×930×765		
Heat Exchanger		Cross fin coil		Cross fin coil		
Comp.	Type	Hermetically sealed scroll type		Hermetically sealed scroll type		
	Piston Displacement	m ³ /h	(13.34+10.53)×2		(13.34+10.53)×2	
	Number of Revolutions	r.p.m	(6300, 2900)×2		(6300, 2900)×2	
	Motor Output×Number of Units	kW	(3.5+4.5)×1+(2.2+4.5)×1		(3.5+4.5)×2	
	Starting Method		Soft start		Soft start	
Fan	Type	Propellor fan		Propellor fan		
	Motor Output	kW	(0.75×1)+(0.75×1)		0.75×2	
	Air Flow Rate	l/s	3,083+3,333		3,333+3,333	
		m ³ /min	185+200		200+200	
Drive		Direct drive		Direct drive		
Connecting Pipes	Liquid Pipe	φ15.9 C1220T (Brazing connection)		φ15.9 C1220T (Brazing connection)		
	Suction Gas Pipe	φ28.6 C1220T (Brazing connection)		φ34.9 C1220T (Brazing connection)		
	High and Low Pressure Gas Pipe	φ28.6 C1220T (Brazing connection)		φ28.6 C1220T (Brazing connection)		
	Pressure Equalizer Tube	φ19.1 C1220T (Brazing connection)		φ19.1 C1220T (Brazing connection)		
Mass (Weight)	kg	254+254		254+254		
Safety Devices		High pressure switch, fan driver overload protector, overcurrent relay, inverter overload protector		High pressure switch, fan driver overload protector, overcurrent relay, inverter overload protector		
Defrost Method		Deicer		Deicer		
Capacity Control	%	7~100		6~100		
Refrigerant	Refrigerant Name		R-410A		R-410A	
	Charge	kg	9.0+9.1		9.1+9.1	
	Control		Electronic expansion valve		Electronic expansion valve	
Refrigerator Oil		Refer to the nameplate of compressor		Refer to the nameplate of compressor		
Standard Accessories		Installation manual, Operation manual, Connection pipes, Cramps		Installation manual, Operation manual, Connection pipes, Cramps		
Drawing No.		4D057570A		4D057571A		

Notes:

- ★1 Indoor temp. : 27°CDB, 19.5°CWB / outdoor temp. : 35°CDB / Equivalent piping length : 7.5m, level difference : 0m.
- ★2 Indoor temp. : 27°CDB, 19.0°CWB / outdoor temp. : 35°CDB / Equivalent piping length : 7.5m, level difference : 0m.
- ★3 Indoor temp. : 20°CDB / outdoor temp. : 7°CDB, 6°CWB / Equivalent piping length : 7.5m, level difference : 0m.

Conversion Formulae
kcal/h=kW×860
Btu/h=kW×3412
cfm=m ³ /min×35.3

Model Name (Combination Unit)		REYQ26P8Y1B		REYQ28P8Y1B		
Model Name (Independent Unit)		REMQ10P8Y1B+REMQ16P8Y1B		REMQ12P8Y1B+REMQ16P8Y1B		
★1 Cooling Capacity (19.5°CWB)	kcal / h	63,100		67,900		
	Btu / h	250,000		270,000		
	kW	73.4		79.0		
★2 Cooling Capacity (19.0°CWB)	kW	73.0		78.5		
★3 Heating Capacity	kcal / h	70,100		75,300		
	Btu / h	278,000		299,000		
	kW	81.5		87.5		
Casing Color	Y1 Type	Ivory White 5Y7.5/1		Ivory White 5Y7.5/1		
	Y1E Type	Light Camel 2.5Y6.5/1.5		Light Camel 2.5Y6.5/1.5		
Dimensions: (H×W×D)	mm	1680×930×765+1680×1240×765		1680×930×765+1680×1240×765		
Heat Exchanger		Cross fin coil		Cross fin coil		
Comp.	Type		Hermetically sealed scroll type		Hermetically sealed scroll type	
	Piston Displacement	m³/h	(13.34+10.53+10.53)+(13.34+10.53)		(13.34+10.53+10.53)+(13.34+10.53)	
	Number of Revolutions	r.p.m	(6300, 2900, 2900)+(6300, 2900)		(6300, 2900, 2900)+(6300, 2900)	
	Motor Output×Number of Units	kW	(3.2+4.5+4.5)×1+(2.2+4.5)×1		(3.2+4.5+4.5)×1+(3.5+4.5)×1	
	Starting Method		Soft start		Soft start	
Fan	Type		Propellor fan		Propellor fan	
	Motor Output	kW	(0.75×1)+(0.35×2)		(0.75×1)+(0.35×2)	
	Air Flow Rate	l/s	3,083+3,833		3,333+3,833	
		m³/min	185+230		200+230	
Drive		Direct drive		Direct drive		
Connecting Pipes	Liquid Pipe		φ19.1 C1220T (Brazing connection)		φ19.1 C1220T (Brazing connection)	
	Suction Gas Pipe		φ34.9 C1220T (Brazing connection)		φ34.9 C1220T (Brazing connection)	
	High and Low Pressure Gas Pipe		φ28.6 C1220T (Brazing connection)		φ28.6 C1220T (Brazing connection)	
	Pressure Equalizer Tube		φ19.1 C1220T (Brazing connection)		φ19.1 C1220T (Brazing connection)	
Mass (Weight)	kg	254+334		254+334		
Safety Devices		High pressure switch, fan driver overload protector, overcurrent relay, inverter overload protector		High pressure switch, fan driver overload protector, overcurrent relay, inverter overload protector		
Defrost Method		Deicer		Deicer		
Capacity Control	%	6~100		6~100		
Refrigerant	Refrigerant Name		R-410A		R-410A	
	Charge	kg	9.0+11.7		9.1+11.7	
	Control		Electronic expansion valve		Electronic expansion valve	
Refrigerator Oil		Refer to the nameplate of compressor		Refer to the nameplate of compressor		
Standard Accessories		Installation manual, Operation manual, Connection pipes, Cramps		Installation manual, Operation manual, Connection pipes, Cramps		
Drawing No.		4D057572A		4D057808A		

Notes:

- ★1 Indoor temp. : 27°CDB, 19.5°CWB / outdoor temp. : 35°CDB / Equivalent piping length : 7.5m, level difference : 0m.
- ★2 Indoor temp. : 27°CDB, 19.0°CWB / outdoor temp. : 35°CDB / Equivalent piping length : 7.5m, level difference : 0m.
- ★3 Indoor temp. : 20°CDB / outdoor temp. : 7°CDB, 6°CWB / Equivalent piping length : 7.5m, level difference : 0m.

Conversion Formulae
kcal/h=kW×860
Btu/h=kW×3412
cfm=m³/min×35.3

Model Name (Combination Unit)		REYQ30P8Y1B		REYQ32P8Y1B		
Model Name (Independent Unit)		REMQ14P8Y1B+REMQ16P8Y1B		REMQ16P8Y1B+REMQ16P8Y1B		
★1 Cooling Capacity (19.5°CWB)	kcal / h	73,500		77,800		
	Btu / h	292,000		309,000		
	kW	85.5		90.5		
★2 Cooling Capacity (19.0°CWB)	kW	85.0		90.0		
★3 Heating Capacity	kcal / h	81,700		86,000		
	Btu / h	324,000		341,000		
	kW	95.0		100		
Casing Color	Y1 Type	Ivory White 5Y7.5/1		Ivory White 5Y7.5/1		
	Y1E Type	Light Camel 2.5Y6.5/1.5		Light Camel 2.5Y6.5/1.5		
Dimensions: (H×W×D)	mm	1680×1240×765+1680×1240×765		1680×1240×765+1680×1240×765		
Heat Exchanger		Cross fin coil		Cross fin coil		
Comp.	Type		Hermetically sealed scroll type		Hermetically sealed scroll type	
	Piston Displacement	m ³ /h	(13.34+10.53+10.53)×2		(13.34+10.53+10.53)×2	
	Number of Revolutions	r.p.m	(6300, 2900, 2900)×2		(6300, 2900, 2900)×2	
	Motor Output×Number of Units	kW	(3.2+4.5+4.5)×1+(1.9+4.5+4.5)×1		(3.2+4.5+4.5)×2	
	Starting Method		Soft start		Soft start	
Fan	Type		Propellor fan		Propellor fan	
	Motor Output	kW	(0.35×2)+(0.35×2)		(0.35×2)×2	
	Air Flow Rate	l/s	3,833+3,833		3,833+3,833	
		m ³ /min	230+230		230+230	
Drive		Direct drive		Direct drive		
Connecting Pipes	Liquid Pipe		φ19.1 C1220T (Brazing connection)		φ19.1 C1220T (Brazing connection)	
	Suction Gas Pipe		φ34.9 C1220T (Brazing connection)		φ34.9 C1220T (Brazing connection)	
	High and Low Pressure Gas Pipe		φ28.6 C1220T (Brazing connection)		φ28.6 C1220T (Brazing connection)	
	Pressure Equalizer Tube		φ19.1 C1220T (Brazing connection)		φ19.1 C1220T (Brazing connection)	
Mass (Weight)	kg	334+334		334+334		
Safety Devices		High pressure switch, fan driver overload protector, overcurrent relay, inverter overload protector		High pressure switch, fan driver overload protector, overcurrent relay, inverter overload protector		
Defrost Method		Deicer		Deicer		
Capacity Control	%	5~100		5~100		
Refrigerant	Refrigerant Name		R-410A		R-410A	
	Charge	kg	11.7+11.7		11.7+11.7	
	Control		Electronic expansion valve		Electronic expansion valve	
Refrigerator Oil		Refer to the nameplate of compressor		Refer to the nameplate of compressor		
Standard Accessories		Installation manual, Operation manual, Connection pipes, Cramps		Installation manual, Operation manual, Connection pipes, Cramps		
Drawing No.		4D057809A		4D057810A		

Notes:

- ★1 Indoor temp. : 27°CDB, 19.5°CWB / outdoor temp. : 35°CDB / Equivalent piping length : 7.5m, level difference : 0m.
- ★2 Indoor temp. : 27°CDB, 19.0°CWB / outdoor temp. : 35°CDB / Equivalent piping length : 7.5m, level difference : 0m.
- ★3 Indoor temp. : 20°CDB / outdoor temp. : 7°CDB, 6°CWB / Equivalent piping length : 7.5m, level difference : 0m.

Conversion Formulae
kcal/h=kW×860
Btu/h=kW×3412
cfm=m ³ /min×35.3

Model Name (Combination Unit)		REYQ34P8Y1B		REYQ36P8Y1B		
Model Name (Independent Unit)		REM8P8Y1B+REM10P8Y1B+REM16P8Y1B		REM8P8Y1B+REM12P8Y1B+REM16P8Y1B		
★1 Cooling Capacity (19.5°CWB)	kcal / h	82,600		87,700		
	Btu / h	328,000		348,000		
	kW	96.0		102		
★2 Cooling Capacity (19.0°CWB)	kW	95.4		101		
★3 Heating Capacity	kcal / h	92,000		97,200		
	Btu / h	365,000		386,000		
	kW	107		113		
Casing Color	Y1 Type	Ivory White 5Y7.5/1		Ivory White 5Y7.5/1		
	Y1E Type	Light Camel 2.5Y6.5/1.5		Light Camel 2.5Y6.5/1.5		
Dimensions: (H×W×D)	mm	1680×930×765+1680×930×765+1680×1240×765		1680×930×765+1680×930×765+1680×1240×765		
Heat Exchanger		Cross fin coil		Cross fin coil		
Comp.	Type	Hermetically sealed scroll type		Hermetically sealed scroll type		
	Piston Displacement	m ³ /h	(13.34+10.53+10.53)+(13.34+10.53)+16.90		(13.34+10.53+10.53)+(13.34+10.53)+16.90	
	Number of Revolutions	r.p.m	(6300, 2900, 2900)+(6300, 2900)+7980		(6300, 2900, 2900)+(6300, 2900)+7980	
	Motor Output×Number of Units	kW	(3.2+4.5+4.5)×1+(2.2+4.5)×1+4.7×1		(3.2+4.5+4.5)×1+(3.5+4.5)×1+4.7×1	
	Starting Method		Soft start		Soft start	
Fan	Type	Propellor fan		Propellor fan		
	Motor Output	kW	(0.75×1)+(0.75×1)+(0.35×2)		(0.75×1)+(0.75×1)+(0.35×2)	
	Air Flow Rate	l/s	3,000+3,083+3,833		3,000+3,333+3,833	
		m ³ /min	180+185+230		180+200+230	
Drive		Direct drive		Direct drive		
Connecting Pipes	Liquid Pipe	φ19.1 C1220T (Brazing connection)		φ19.1 C1220T (Brazing connection)		
	Suction Gas Pipe	φ34.9 C1220T (Brazing connection)		φ41.3 C1220T (Brazing connection)		
	High and Low Pressure Gas Pipe	φ28.6 C1220T (Brazing connection)		φ28.6 C1220T (Brazing connection)		
	Pressure Equalizer Tube	φ19.1 C1220T (Brazing connection)		φ19.1 C1220T (Brazing connection)		
Mass (Weight)	kg	204+254+334		204+254+334		
Safety Devices		High pressure switch, fan driver overload protector, overcurrent relay, inverter overload protector		High pressure switch, fan driver overload protector, overcurrent relay, inverter overload protector		
Defrost Method		Deicer		Deicer		
Capacity Control	%	5~100		5~100		
Refrigerant	Refrigerant Name		R-410A		R-410A	
	Charge	kg	8.2+9.0+11.7		8.2+9.1+11.7	
	Control		Electronic expansion valve		Electronic expansion valve	
Refrigerator Oil		Refer to the nameplate of compressor		Refer to the nameplate of compressor		
Standard Accessories		Installation manual, Operation manual, Connection pipes, Cramps		Installation manual, Operation manual, Connection pipes, Cramps		
Drawing No.		4D057811A		4D057812A		

Notes:

- ★1 Indoor temp. : 27°CDB, 19.5°CWB / outdoor temp. : 35°CDB / Equivalent piping length : 7.5m, level difference : 0m.
- ★2 Indoor temp. : 27°CDB, 19.0°CWB / outdoor temp. : 35°CDB / Equivalent piping length : 7.5m, level difference : 0m.
- ★3 Indoor temp. : 20°CDB / outdoor temp. : 7°CDB, 6°CWB / Equivalent piping length : 7.5m, level difference : 0m.

Conversion Formulae
kcal/h=kW×860
Btu/h=kW×3412
cfm=m ³ /min×35.3

Model Name (Combination Unit)		REYQ38P8Y1B		REYQ40P8Y1B		
Model Name (Independent Unit)		REMQ10P8Y1B+REMQ12P8Y1B+REMQ16P8Y1B		REMQ12P8Y1B+REMQ12P8Y1B+REMQ16P8Y1B		
★1 Cooling Capacity (19.5°CWB)	kcal / h	92,900		97,200		
	Btu / h	368,000		386,000		
	kW	108		113		
★2 Cooling Capacity (19.0°CWB)	kW	107		112		
★3 Heating Capacity	kcal / h	102,000		108,000		
	Btu / h	406,000		427,000		
	kW	119		125		
Casing Color	Y1 Type	Ivory White 5Y7.5/1		Ivory White 5Y7.5/1		
	Y1E Type	Light Camel 2.5Y6.5/1.5		Light Camel 2.5Y6.5/1.5		
Dimensions: (H×W×D)	mm	1680×930×765+1680×930×765+1680×1240×765		1680×930×765+1680×930×765+1680×1240×765		
Heat Exchanger		Cross fin coil		Cross fin coil		
Comp.	Type		Hermetically sealed scroll type		Hermetically sealed scroll type	
	Piston Displacement	m ³ /h	(13.34+10.53+10.53)+(13.34+10.53)×2		(13.34+10.53+10.53)+(13.34+10.53)×2	
	Number of Revolutions	r.p.m	(6300, 2900, 2900)+(6300, 2900)×2		(6300, 2900, 2900)+(6300, 2900)×2	
	Motor Output×Number of Units	kW	(3.2+4.5+4.5)×1+(3.5+4.5)×1+(2.2+4.5)×1		(3.2+4.5+4.5)×1+(3.5+4.5)×2	
	Starting Method		Soft start		Soft start	
Fan	Type		Propellor fan		Propellor fan	
	Motor Output	kW	(0.75×1)+(0.75×1)+(0.35×2)		(0.75×2)+(0.35×2)	
	Air Flow Rate	l/s	3,083+3,333+3,833		3,333+3,333+3,833	
		m ³ /min	185+200+230		200+200+230	
Drive		Direct drive		Direct drive		
Connecting Pipes	Liquid Pipe		φ19.1 C1220T (Brazing connection)		φ19.1 C1220T (Brazing connection)	
	Suction Gas Pipe		φ41.3 C1220T (Brazing connection)		φ41.3 C1220T (Brazing connection)	
	High and Low Pressure Gas Pipe		φ34.9 C1220T (Brazing connection)		φ34.9 C1220T (Brazing connection)	
	Pressure Equalizer Tube		φ19.1 C1220T (Brazing connection)		φ19.1 C1220T (Brazing connection)	
Mass (Weight)	kg	254+254+334		254+254+334		
Safety Devices		High pressure switch, fan driver overload protector, overcurrent relay, inverter overload protector		High pressure switch, fan driver overload protector, overcurrent relay, inverter overload protector		
Defrost Method		Deicer		Deicer		
Capacity Control	%	5~100		4~100		
Refrigerant	Refrigerant Name		R-410A		R-410A	
	Charge	kg	9.0+9.1+11.7		9.1+9.1+11.7	
	Control		Electronic expansion valve		Electronic expansion valve	
Refrigerator Oil		Refer to the nameplate of compressor		Refer to the nameplate of compressor		
Standard Accessories		Installation manual, Operation manual, Connection pipes, Cramps		Installation manual, Operation manual, Connection pipes, Cramps		
Drawing No.		4D057813A		4D057814A		

Notes:

- ★1 Indoor temp. : 27°CDB, 19.5°CWB / outdoor temp. : 35°CDB / Equivalent piping length : 7.5m, level difference : 0m.
- ★2 Indoor temp. : 27°CDB, 19.0°CWB / outdoor temp. : 35°CDB / Equivalent piping length : 7.5m, level difference : 0m.
- ★3 Indoor temp. : 20°CDB / outdoor temp. : 7°CDB, 6°CWB / Equivalent piping length : 7.5m, level difference : 0m.

Conversion Formulae
kcal/h=kW×860
Btu/h=kW×3412
cfm=m ³ /min×35.3

Model Name (Combination Unit)		REYQ42P8Y1B		REYQ44P8Y1B		
Model Name (Independent Unit)		REMQR10P8Y1B+REMQR16P8Y1B+REMQR16P8Y1B		REMQR12P8Y1B+REMQR16P8Y1B+REMQR16P8Y1B		
★1 Cooling Capacity (19.5°CWB)	kcal / h	102,000		108,000		
	Btu / h	406,000		427,000		
	kW	119		125		
★2 Cooling Capacity (19.0°CWB)	kW	118		124		
★3 Heating Capacity	kcal / h	114,000		119,000		
	Btu / h	450,000		471,000		
	kW	132		138		
Casing Color	Y1 Type	Ivory White 5Y7.5/1		Ivory White 5Y7.5/1		
	Y1E Type	Light Camel 2.5Y6.5/1.5		Light Camel 2.5Y6.5/1.5		
Dimensions: (H×W×D)	mm	1680×930×765+1680×1240×765+1680×1240×765		1680×930×765+1680×1240×765+1680×1240×765		
Heat Exchanger		Cross fin coil		Cross fin coil		
Comp.	Type	Hermetically sealed scroll type		Hermetically sealed scroll type		
	Piston Displacement	m ³ /h	(13.34+10.53+10.53)×2+(13.34+10.53)		(13.34+10.53+10.53)×2+(13.34+10.53)	
	Number of Revolutions	r.p.m	(6300, 2900, 2900)×2+(6300, 2900)		(6300, 2900, 2900)×2+(6300, 2900)	
	Motor Output×Number of Units	kW	(3.2+4.5+4.5)×1+(2.2+4.5)×1		(3.2+4.5+4.5)×2+(3.5+4.5)×1	
	Starting Method		Soft start		Soft start	
Fan	Type	Propellor fan		Propellor fan		
	Motor Output	kW	(0.75×1)+(0.35×2)×2		(0.75×1)+(0.35×2)×2	
	Air Flow Rate	l/s	3,083+3,833+3,833		3,333+3,833+3,833	
		m ³ /min	185+230+230		200+230+230	
Drive		Direct drive		Direct drive		
Connecting Pipes	Liquid Pipe	φ19.1 C1220T (Brazing connection)		φ19.1 C1220T (Brazing connection)		
	Suction Gas Pipe	φ41.3 C1220T (Brazing connection)		φ41.3 C1220T (Brazing connection)		
	High and Low Pressure Gas Pipe	φ34.9 C1220T (Brazing connection)		φ34.9 C1220T (Brazing connection)		
	Pressure Equalizer Tube	φ19.1 C1220T (Brazing connection)		φ19.1 C1220T (Brazing connection)		
Mass (Weight)	kg	254+334+334		254+334+334		
Safety Devices		High pressure switch, fan driver overload protector, overcurrent relay, inverter overload protector		High pressure switch, fan driver overload protector, overcurrent relay, inverter overload protector		
Defrost Method		Deicer		Deicer		
Capacity Control	%	4~100		4~100		
Refrigerant	Refrigerant Name		R-410A		R-410A	
	Charge	kg	9.0+11.7+11.7		9.1+11.7+11.7	
	Control		Electronic expansion valve		Electronic expansion valve	
Refrigerator Oil		Refer to the nameplate of compressor		Refer to the nameplate of compressor		
Standard Accessories		Installation manual, Operation manual, Connection pipes, Cramps		Installation manual, Operation manual, Connection pipes, Cramps		
Drawing No.		4D057815A		4D057816A		

Notes:

- ★1 Indoor temp. : 27°CDB, 19.5°CWB / outdoor temp. : 35°CDB / Equivalent piping length : 7.5m, level difference : 0m.
- ★2 Indoor temp. : 27°CDB, 19.0°CWB / outdoor temp. : 35°CDB / Equivalent piping length : 7.5m, level difference : 0m.
- ★3 Indoor temp. : 20°CDB / outdoor temp. : 7°CDB, 6°CWB / Equivalent piping length : 7.5m, level difference : 0m.

Conversion Formulae
kcal/h=kW×860
Btu/h=kW×3412
cfm=m ³ /min×35.3

Model Name (Combination Unit)		REYQ46P8Y1B		REYQ48P8Y1B		
Model Name (Independent Unit)		REMQR14P8Y1B+REMQR16P8Y1B+REMQR16P8Y1B		REMQR16P8Y1B+REMQR16P8Y1B+REMQR16P8Y1B		
★1 Cooling Capacity (19.5°CWB)	kcal / h	113,000		117,000		
	Btu / h	447,000		464,000		
	kW	131		136		
★2 Cooling Capacity (19.0°CWB)	kW	130		135		
★3 Heating Capacity	kcal / h	124,000		129,000		
	Btu / h	495,000		512,000		
	kW	145		150		
Casing Color	Y1 Type	Ivory White 5Y7.5/1		Ivory White 5Y7.5/1		
	Y1E Type	Light Camel 2.5Y6.5/1.5		Light Camel 2.5Y6.5/1.5		
Dimensions: (H×W×D)	mm	1680×1240×765+1680×1240×765+1680×1240×765		1680×1240×765+1680×1240×765+1680×1240×765		
Heat Exchanger		Cross fin coil		Cross fin coil		
Comp.	Type	Hermetically sealed scroll type		Hermetically sealed scroll type		
	Piston Displacement	m ³ /h	(13.34+10.53+10.53)×3		(13.34+10.53+10.53)×3	
	Number of Revolutions	r.p.m	(6300, 2900, 2900)×3		(6300, 2900, 2900)×3	
	Motor Output×Number of Units	kW	(3.2+4.5+4.5)×2+(1.9+4.5+4.5)×1		(3.2+4.5+4.5)×3	
	Starting Method		Soft start		Soft start	
Fan	Type	Propellor fan		Propellor fan		
	Motor Output	kW	(0.35×2)+(0.35×2)×2		(0.35×2)×3	
	Air Flow Rate	l/s	3,833+3,833+3,833		3,833+3,833+3,833	
		m ³ /min	230+230+230		230+230+230	
Drive		Direct drive		Direct drive		
Connecting Pipes	Liquid Pipe	φ19.1 C1220T (Brazing connection)		φ19.1 C1220T (Brazing connection)		
	Suction Gas Pipe	φ41.3 C1220T (Brazing connection)		φ41.3 C1220T (Brazing connection)		
	High and Low Pressure Gas Pipe	φ34.9 C1220T (Brazing connection)		φ34.9 C1220T (Brazing connection)		
	Pressure Equalizer Tube	φ19.1 C1220T (Brazing connection)		φ19.1 C1220T (Brazing connection)		
Mass (Weight)	kg	334+334+334		334+334+334		
Safety Devices		High pressure switch, fan driver overload protector, overcurrent relay, inverter overload protector		High pressure switch, fan driver overload protector, overcurrent relay, inverter overload protector		
Defrost Method		Deicer		Deicer		
Capacity Control	%	4~100		4~100		
Refrigerant	Refrigerant Name		R-410A		R-410A	
	Charge	kg	11.7+11.7+11.7		11.7+11.7+11.7	
	Control		Electronic expansion valve		Electronic expansion valve	
Refrigerator Oil		Refer to the nameplate of compressor		Refer to the nameplate of compressor		
Standard Accessories		Installation manual, Operation manual, Connection pipes, Cramps		Installation manual, Operation manual, Connection pipes, Cramps		
Drawing No.		4D057817A		4D057818A		

Notes:

- ★1 Indoor temp. : 27°CDB, 19.5°CWB / outdoor temp. : 35°CDB / Equivalent piping length : 7.5m, level difference : 0m.
- ★2 Indoor temp. : 27°CDB, 19.0°CWB / outdoor temp. : 35°CDB / Equivalent piping length : 7.5m, level difference : 0m.
- ★3 Indoor temp. : 20°CDB / outdoor temp. : 7°CDB, 6°CWB / Equivalent piping length : 7.5m, level difference : 0m.

Conversion Formulae
kcal/h=kW×860
Btu/h=kW×3412
cfm=m ³ /min×35.3

1.2 Indoor Units

Roundflow Ceiling Mounted Cassette

1-1 TECHNICAL SPECIFICATIONS				FXFQ20PVEB	FXFQ25PVEB	FXFQ32PVEB	FXFQ40PVEB	FXFQ50PVEB	
Capacity	Cooling	kW	2.2	2.8	3.6	4.5	5.6		
	Heating	kW	2.5	3.2	4.0	5.0	6.3		
Power Input	Cooling	kW	0.053	0.053	0.053	0.063	0.083		
	Heating	kW	0.045	0.045	0.045	0.055	0.067		
Casing	Material		Galvanised steel						
Dimensions	Packing	Height	mm	220	220	220	220	220	
		Width	mm	882	882	882	882	882	
		Depth	mm	882	882	882	882	882	
	Unit	Height	mm	204	204	204	204	204	
		Width	mm	840	840	840	840	840	
		Depth	mm	840	840	840	840	840	
Weight	Unit	kg	20.0	20.0	20.0	20.0	21.0		
	Packed Unit	kg	24.0	24.0	24.0	24.0	26.0		
Dimensions	Length	Inside	mm	2,096					
		Outside	mm	2,152					
Heat Exchanger	Dimensions	Nr of Rows		2	2	2	2	2	
		Fin Pitch	mm	1.2	1.2	1.2	1.2	1.2	
		Nr of Passes		2	2	3	3	7	
		Face Area	m ²	0.267	0.267	0.267	0.267	0.357	
		Nr of Stages		6	6	6	6	8	
	Empty Tubeplate Hole		4	4					
Fin	Fin type		Cross fin coil (Multi louver fins and Hi-XSS tubes)						
Fan	Type		Turbo fan						
	Quantity		1	1	1	1	1		
Air Flow Rate	Cooling	High	m ³ /min	12.5	12.5	12.5	13.5	15.5	
		Low	m ³ /min	9.0	9.0	9.0	9.0	10.0	
	Heating	High	m ³ /min	12.5	12.5	12.5	13.5	15.0	
		Low	m ³ /min	9.0	9.0	9.0	9.0	9.5	
Fan	Motor	Model		QTS48D11M					
		Steps		2	2	2	2	2	
		Output (high)	W	56	56	56	56	56	
Refrigerant	Name		R-410A						
Sound Level	Cooling	Sound power (nominal)	dBA	49	49	49	50	51	
Cooling	Sound Pressure	High	dBA	31	31	31	32	33	
		Low	dBA	28	28	28	28	28	
Heating	Sound Pressure	High	dBA	31	31	31	32	33	
		Low	dBA	28	28	28	28	28	
Piping connections	Liquid (OD)	Type		Flare connection					
		Diameter	mm	6.35	6.4	6.4	6.4	6.4	
	Gas	Type		Flare connection					
		Diameter	mm	12.7	12.7	12.7	12.7	12.7	
	Drain	Diameter		VP25 (I.D. 25/O.D. 32)					
	Heat Insulation		Foamed polystyrene/polyethylene						
Sound absorbing insulation		(Foamed Polyurethane)							
Decoration Panel	Model		BYCQ140CW1						
	Colour		RAL9010						
	Dimensions	Height	mm	50	50	50	50	50	
		Width	mm	950	950	950	950	950	
		Depth	mm	950	950	950	950	950	
Weight		kg	5.5	5.5	5.5	5.5	5.5		
Air Filter	Resin net with mold resistance								

Roundflow Ceiling Mounted Cassette

1-1 TECHNICAL SPECIFICATIONS				FXFQ20PVEB	FXFQ25PVEB	FXFQ32PVEB	FXFQ40PVEB	FXFQ50PVEB		
Standard Accessories	Standard Accessories			Installation and operation manual						
				Drain hose						
				Washer for hanging bracket						
				Screws						
				Sealing Pads						
				Insulation for fitting						
				Clamp for drain hose						
				Installation guide						
				Drain sealing pad						
Notes				The sound pressure values are mentioned for a unit installed with rear suction						
				The sound power level is an absolute value indicating the power with a sound source generates.						
				Nominal cooling capacities are based on: indoor temperature: 27°CDB, 19°CWB, outdoor temperature: 35°CDB, equivalent refrigerant piping: 5m, level difference: 0m.						
				Nominal heating capacities are based on: indoor temperature: 20°CDB, outdoor temperature: 7°CDB, 6°CWB, equivalent refrigerant piping : 5m (horizontal)						
				Capacities are net, including a deduction for cooling (an addition for heating) for indoor fan motor heat.						

1-1 TECHNICAL SPECIFICATIONS				FXFQ63PVEB	FXFQ80PVEB	FXFQ100PVEB	FXFQ125PVEB
Capacity	Cooling	kW		7.1	9.0	11.2	14.0
	Heating	kW		8.0	10.0	12.5	16.0
Power Input	Cooling	kW		0.095	0.120	0.173	0.258
	Heating	kW		0.114	0.108	0.176	0.246
Casing	Material			Galvanised steel			
Dimensions	Packing	Height	mm	220	262	262	304
		Width	mm	882	882	882	882
		Depth	mm	882	882	882	882
	Unit	Height	mm	204	246	246	288
		Width	mm	840	840	840	840
	Depth	mm	840	840	840	840	
Weight	Unit	kg		21.0	24.0	24.0	26.0
	Packed Unit	kg		26.0	28.0	28.0	31.0
Dimensions	Length	Inside	mm	2,096			
		Outside	mm	2,152			
Heat Exchanger	Dimensions	Nr of Rows		2	2	2	2
		Fin Pitch	mm	1.2	1.2	1.2	1.2
		Nr of Passes		7	9	9	11
		Face Area	m ²	0.357	0.446	0.446	0.535
	Nr of Stages		8	10	10	12	
	Fin	Fin type					
	Cross fin coil (Multi louver fins and Hi-XSS tubes)						
Fan	Type			Turbo fan			
	Quantity			1	1	1	1
Air Flow Rate	Cooling	High	m ³ /min	16.5	23.5	26.5	33.0
		Low	m ³ /min	11.0	14.5	17.0	20.0
	Heating	High	m ³ /min	17.5	23.5	28.0	33.0
		Low	m ³ /min	12.0	14.5	17.5	20.0
Fan	Motor	Model		QTS48D11M	QTS48C15M	QTS48C15M	QTS48C15M
		Steps		2	2	2	2
		Output (high)	W	56	120	120	120
Refrigerant	Name			R-410A			
Sound Level	Cooling	Sound power (nominal)	dB(A)	52	55	58	61
Cooling	Sound Pressure	High	dB(A)	34	38	41	44
		Low	dB(A)	29	32	33	34
Heating	Sound Pressure	High	dB(A)	36	38	42	44
		Low	dB(A)	30	32	34	34

Roundflow Ceiling Mounted Cassette

1-1 TECHNICAL SPECIFICATIONS				FXFQ63PVEB	FXFQ80PVEB	FXFQ100PVEB	FXFQ125PVEB
Piping connections	Liquid (OD)	Type		Flare connection			
		Diameter	mm	9.5	9.5	9.5	9.5
	Gas	Type		Flare connection			
		Diameter	mm	15.9	15.9	15.9	15.9
	Drain	Diameter	mm	VP25 (I.D. 25/O.D. 32)			
Heat Insulation		Foamed polystyrene/polyethylene					
Sound absorbing insulation		(Foamed Polyurethane)					
Decoration Panel	Model			BYCQ140CW1			
	Colour			RAL9010			
	Dimensions	Height	mm	50	50	50	50
		Width	mm	950	950	950	950
		Depth	mm	950	950	950	950
Weight		kg	5.5	5.5	5.5	5.5	
Air Filter				Resin net with mold resistance			
Standard Accessories	Standard Accessories			Installation and operation manual			
				Drain hose			
				Washer for hanging bracket			
				Screws			
				Sealing Pads			
				Insulation for fitting			
				Clamp for drain hose			
				Installation guide			
				Drain sealing pad			
				Notes			

1-2 ELECTRICAL SPECIFICATIONS			FXFQ20PVEB	FXFQ25PVEB	FXFQ32PVEB	FXFQ40PVEB	FXFQ50PVEB
Power Supply	Name		VE				
	Frequency	Hz	50/60				
	Voltage	V	220-240/220				
Current	Minimum circuit amps (MCA)	A	0.4	0.4	0.4	0.5	0.6
	Maximum fuse amps (MFA)	A	16	16	16	16	16
	Full load amps (FLA)	A	0.3	0.3	0.3	0.4	0.5
Voltage range	Minimum	V	-10%				
	Maximum	V	+10%				
Notes			Voltage range : units are suitable for use on electrical systems where voltage supplied to unit terminals is not below or above listed range limits.				
			Maximum allowable voltage range variation between phases is 2%.				
			MCA/MFA : MCA = 1.25 × FLA				
			MFA <= 4 × FLA				
			next lower standard fuse rating minimum 16A				
			select wire size based on the MCA				
			instead of a fuse, use a circuit breaker				

1-2 ELECTRICAL SPECIFICATIONS			FXFQ63PVEB	FXFQ80PVEB	FXFQ100PVEB	FXFQ125PVEB
Power Supply	Name		VE			
	Frequency	Hz	50/60			
	Voltage	V	220-240/220			
Current	Minimum circuit amps (MCA)	A	0.9	0.9	1.4	1.9
	Maximum fuse amps (MFA)	A	16	16	16	16
	Full load amps (FLA)	A	0.7	0.7	1.1	1.5
Voltage range	Minimum	V	-10%			
	Maximum	V	+10%			
Notes			Voltage range : units are suitable for use on electrical systems where voltage supplied to unit terminals is not below or above listed range limits.			
			Maximum allowable voltage range variation between phases is 2%.			
			MCA/MFA : MCA = 1.25 × FLA			
			MFA <= 4 × FLA			
			next lower standard fuse rating minimum 16A			
			select wire size based on the MCA			
			instead of a fuse, use a circuit breaker			

600×600 4-Way Blow Ceiling Mounted Cassette

1-1 TECHNICAL SPECIFICATIONS				FXZQ20MV1B	FXZQ25MV1B	FXZQ32MV1B	FXZQ40MV1B	FXZQ50MV1B
Nominal Capacity	Cooling		kW	2.20	2.80	3.60	4.50	5.60
	Heating		kW	2.50	3.20	4.00	5.00	6.30
Power input (Nominal)	Cooling		kW	0.073	0.073	0.076	0.089	0.115
	Heating		kW	0.064	0.064	0.068	0.080	0.107
Casing	Material			Galvanised steel				
Dimensions	Unit	Height	mm	286	286	286	286	286
		Width	mm	575	575	575	575	575
		Depth	mm	575	575	575	575	575
Weight	Unit		kg	18	18	18	18	18
Heat Exchanger	Dimensions	Nr of Rows		2	2	2	2	2
		Fin Pitch	mm	1.50	1.50	1.50	1.50	1.50
		Face Area	m ²	0.269	0.269	0.269	0.269	0.269
		Nr of Stages		10	10	10	10	10
Fan	Type			Turbo fan				
	Quantity			1	1	1	1	1
Air Flow Rate	Cooling	High	m ³ /min	9.00	9.00	9.50	11.00	14.00
		Low	m ³ /min	7.00	7.00	7.50	8.00	10.00
Fan	Motor	Quantity		1	1	1	1	1
		Model			QTS32C15M			
	Output (high)	W	55	55	55	55	55	
	Drive			Direct drive				
Refrigerant	Name			R-410A				
Sound Level	Cooling	Sound power (nominal)	dBa	47.0	47.0	49.0	53.0	58.0
Cooling	Sound Pressure	High	dBa	30.0	30.0	32.0	36.0	41.0
		Low	dBa	25.0	25.0	26.0	28.0	33.0
Piping connections	Liquid (OD)	Type		Flare connection				
		Diameter	mm	6.4	6.4	6.4	6.4	6.4
	Gas	Type		Flare connection				
		Diameter	mm	12.7	12.7	12.7	12.7	12.7
	Drain	Diameter	mm	26	26	26	26	26
Heat Insulation			Foamed polystyrene/polyethylene					
Decoration Panel	Model			BYFQ60B7W1				
	Colour			White (Ral 9010)				
	Dimensions	Height	mm	55	55	55	55	55
		Width	mm	700	700	700	700	700
		Depth	mm	700	700	700	700	700
Weight		kg	2.7	2.7	2.7	2.7	2.7	
Air Filter	Resin net with mold resistance							
Refrigerant control	Electronic expansion valve							
Temperature control	Microprocessor thermostat for cooling and heating							
Safety devices			PC board fuse					
			Fan motor thermal protector					
Standard Accessories	Standard Accessories		Installation and operation manual					
			Paper pattern for installation					
			Drain hose					
			Clamp metal					
			Washer fixing plate					
			Sealing Pads					
			Clamps					
			Screws					
			Washer for hanger bracket					
			Insulation for fitting					

1-1 TECHNICAL SPECIFICATIONS	FXZQ20MV1B	FXZQ25MV1B	FXZQ32MV1B	FXZQ40MV1B	FXZQ50MV1B
Notes	Nominal cooling capacities are based on : indoor temperature : 27°CDB, 19°CWB, outdoor temperature : 35°CDB, equivalent refrigerant piping : 7.5m (horizontal)				
	Nominal heating capacities are based on : indoor temperature : 20°CDB, outdoor temperature : 7°CDB, 6°CWB, equivalent refrigerant piping : 7.5m (horizontal)				
	Capacities are net, including a deduction for cooling (an addition for heating) for indoor fan motor heat.				

1-2 ELECTRICAL SPECIFICATIONS			FXZQ20MV1B	FXZQ25MV1B	FXZQ32MV1B	FXZQ40MV1B	FXZQ50MV1B
Power Supply	Name		V1				
	Phase		1	1	1	1	1
	Frequency	Hz	50	50	50	50	50
	Voltage	V	220-240				
Current	Minimum circuit amps (MCA)	A	0.80	0.80	0.80	0.80	0.90
	Maximum fuse amps (MFA)	A	15.00	15.00	15.00	15.00	15.00
	Full load amps (FLA)	A	0.60	0.60	0.60	0.60	0.70
Voltage range	Minimum	V	-10%				
	Maximum	V	+10%				
Notes	Voltage range : units are suitable for use on electrical systems where voltage supplied to unit terminals is not below or above listed range limits.						
	Maximum allowable voltage range variation between phases is 2%.						
	MCA/MFA : MCA = 1.25 × FLA						
	MFA <= 4 × FLA						
	next lower standard fuse rating minimum 15A						
	select wire size based on the MCA						
	instead of a fuse, use a circuit breaker						
	For more details concerning conditional connections, see http://extranet.daikineurope.com , select "E-Data Books". Finally, click on the document title of your choice.						

2-Way Blow Ceiling Mounted Cassette

1-1 TECHNICAL SPECIFICATIONS				FXCQ20MV3B	FXCQ25MV3B	FXCQ32MV3B	FXCQ40MV3B	FXCQ50MV3B	
Nominal Capacity	Cooling	kW	2.20	2.80	3.60	4.50	5.60		
	Heating	kW	2.50	3.20	4.00	5.00	6.30		
Power input (Nominal)	Cooling	kW	0.077	0.092	0.092	0.130	0.130		
	Heating	kW	0.044	0.059	0.059	0.097	0.097		
Casing	Colour	Non painted							
	Material	Galvanised steel							
Dimensions	Packing	Height	mm	405	405	405	405	405	
		Width	mm	1,060	1,060	1,060	1,280	1,280	
		Depth	mm	665	665	665	665	665	
	Unit	Height	mm	305	305	305	305	305	
		Width	mm	780	780	780	995	995	
		Depth	mm	600	600	600	600	600	
Weight	Unit	kg	26	26	26	31	32		
	Packed Unit	kg	30	30	30	37	38		
Required Ceiling Void		mm	350	350	350	350	350		
Heat Exchanger	Dimensions	Length	mm	475 × 2	475 × 2	475 × 2	690 × 2	475 × 2	
		Nr of Rows	2 × 2						
		Fin Pitch	mm	1.50	1.50	1.50	1.50	1.50	
		Nr of Passes	3 × 2						
		Face Area	m ²	0.1 × 2	0.1 × 2	0.1 × 2	0.145 × 2	0.145 × 2	
		Nr of Stages	10 × 2						
	Empty Tubeplate Hole	6							
	Tube type	Hi-XSS (7)							
	Fin	Fin type	Symmetric waffle louvre						
		Treatment	Hydrophilic						
Fan	Type	Sirocco fan							
	Quantity			1	1	1	2	2	
Air Flow Rate	Cooling	High	m ³ /min	7.0	9.0	9.0	12.0	12.0	
		Low	m ³ /min	5.0	6.5	6.5	9.0	9.0	
	Heating	High	m ³ /min	7.0	9.0	9.0	12.0	12.0	
		Low	m ³ /min	5.0	6.5	6.5	9.0	9.0	
Fan	Motor	Quantity			1	1	1	1	
		Steps	Phase cut control						
	Output (high)	W	10	15	15	20	20		
	Drive	Direct drive							
Refrigerant	Name	R-410A							
Sound Level	Cooling	Sound power (nominal)	dBa	45.0	50.0	50.0	50.0	50.0	
Cooling	Sound Pressure	High	dBa	33.0	35.0	35.0	35.5	35.5	
		Low	dBa	28.0	29.0	29.0	30.5	30.5	
Heating	Sound Pressure	High	dBa	33.0	35.0	35.0	35.5	35.5	
		Low	dBa	28.0	29.0	29.0	30.5	30.5	
Piping connections	Liquid (OD)	Type	Flare connection						
		Diameter	mm	6.35	6.35	6.35	6.35	6.35	
	Gas	Type	Flare connection						
		Diameter	mm	12.7	12.7	12.7	12.7	12.7	
	Drain	Diameter	mm	32	32	32	32	32	
	Heat Insulation	Both liquid and gas pipes							
Decoration Panel	Model			BYBC32GJW1	BYBC32GJW1	BYBC32GJW1	BYBC50GJW1	BYBC50GJW1	
	Colour	White (10Y9/0,5)							
	Dimensions	Height	mm	53	53	53	53	53	
		Width	mm	1,030	1,030	1,030	1,245	1,245	
		Depth	mm	680	680	680	680	680	
Weight	kg	8.0	8.0	8.0	8.5	8.5			
Drain-up Height		mm	600	600	600	600	600		

2-Way Blow Ceiling Mounted Cassette

1-1 TECHNICAL SPECIFICATIONS		FXCQ20MV3B	FXCQ25MV3B	FXCQ32MV3B	FXCQ40MV3B	FXCQ50MV3B
Air Filter		Resin net with mold resistance				
Air direction control		Up and downwards				
Refrigerant control		Electronic expansion valve				
Temperature control		Microprocessor thermostat for cooling and heating				
Safety devices		PC board fuse				
		Fan motor thermal fuse				
		Drain pump fuse				
Standard Accessories	Standard Accessories	Screws for fixing the paper pattern for installation				
	Quantity	4	4	4	4	4
	Standard Accessories	Washer for hanging bracket				
	Quantity	8	8	8	8	8
	Standard Accessories	Clamps				
	Quantity	1	1	1	1	1
	Standard Accessories	Installation and operation manual				
	Quantity	1	1	1	1	1
	Standard Accessories	Paper pattern for installation				
	Quantity	1	1	1	1	1
	Standard Accessories	Insulation for fitting				
	Quantity	2	2	2	2	2
	Standard Accessories	Drain hose				
	Quantity	1	1	1	1	1
Notes		Nominal cooling capacities are based on : indoor temperature : 27°CDB, 19°CWB, outdoor temperature : 35°CDB, equivalent refrigerant piping : 8m, level difference : 0m.				
		Nominal heating capacities are based on : indoor temperature : 20°CDB, outdoor temperature : 7°CDB, 6°CWB, equivalent refrigerant piping : 8m, level difference : 0m.				
		Capacities are net, including a deduction for cooling (an addition for heating) for indoor fan motor heat.				

1-1 TECHNICAL SPECIFICATIONS				FXCQ63MV3B	FXCQ80MV3B	FXCQ125MV3B
Nominal Capacity	Cooling		kW	7.10	9.00	14.00
	Heating		kW	8.00	10.00	16.00
Power input (Nominal)	Cooling		kW	0.161	0.209	0.256
	Heating		kW	0.126	0.176	0.223
Casing	Colour			Non painted		
	Material			Galvanised steel		
Dimensions	Packing	Height	mm	405	405	405
		Width	mm	1,460	1,808	1,808
		Depth	mm	665	645	645
	Unit	Height	mm	305	305	305
		Width	mm	1,180	1,670	1,670
		Depth	mm	600	600	600
Weight	Unit		kg	35	47	48
	Packed Unit		kg	42	55	56
Required Ceiling Void			mm	350	350	350
Heat Exchanger	Dimensions	Length	mm	875 × 2	1,365	1,365
		Nr of Rows			2 × 2	
		Fin Pitch	mm	1.50	1.50	1.50
		Nr of Passes			6 × 2	6
		Face Area	m ²	0.184 × 2	0.287 × 2	0.287 × 2
		Nr of Stages			10 × 2	
		Empty Tubeplate Hole			8	
	Tube type			Hi-XSS (7)		
	Fin	Fin type		Symmetric waffle louver		
		Treatment		Hydrophilic		
Fan	Type			Sirocco fan		
	Quantity			2	3	3
Air Flow Rate	Cooling	High	m ³ /min	16.5	26.0	33.0
		Low	m ³ /min	13.0	21.0	25.0
	Heating	High	m ³ /min	16.5	26.0	33.0
		Low	m ³ /min	13.0	21.0	25.0
Fan	Motor	Quantity		1	1	1
		Steps		Phase cut control		
	Output (high)	W	30	50	85	
	Drive			Direct drive		
Refrigerant	Name			R-410A		
Sound Level	Cooling	Sound power (nominal)	dBa	52.0	54.0	60.0
Cooling	Sound Pressure	High	dBa	38.0	40.0	45.0
		Low	dBa	33.0	35.0	39.0
Heating	Sound Pressure	High	dBa	38.0	40.0	45.0
		Low	dBa	33.0	35.0	39.0
Piping connections	Liquid (OD)	Type		Flare connection		
		Diameter	mm	9.5	9.5	9.5
	Gas	Type		Flare connection		
		Diameter	mm	15.9	15.9	15.9
	Drain	Diameter	mm	32	32	32
Heat Insulation			Both liquid and gas pipes			
Decoration Panel	Model			BYBC63GJW1	BYBC125GJW1	BYBC125GJW1
	Colour			White (10Y9/0,5)		
	Dimensions	Height	mm	53	53	53
		Width	mm	1,430	1,920	1,920
		Depth	mm	680	680	680
	Weight		kg	9.5	12.0	12.0
Drain-up Height			mm	600	600	600

1-1 TECHNICAL SPECIFICATIONS		FXCQ63MV3B	FXCQ80MV3B	FXCQ125MV3B
Air Filter		Resin net with mold resistance		
Air direction control		Up and downwards		
Refrigerant control		Electronic expansion valve		
Temperature control		Microprocessor thermostat for cooling and heating		
Safety devices		PC board fuse		
		Fan motor thermal fuse	Fan motor thermal protector	Fan motor thermal protector
		Drain pump fuse		
Standard Accessories	Standard Accessories	Screws for fixing the paper pattern for installation		
	Quantity	4	4	4
	Standard Accessories	Washer for hanging bracket		
	Quantity	8	8	8
	Standard Accessories	Clamps		
	Quantity	1	1	1
	Standard Accessories	Installation and operation manual		
	Quantity	1	1	1
	Standard Accessories	Paper pattern for installation		
	Quantity	1	1	1
	Standard Accessories	Insulation for fitting		
	Quantity	2	2	2
	Standard Accessories	Drain hose		
Quantity	1	1	1	
Notes		Nominal cooling capacities are based on : indoor temperature : 27°CDB, 19°CWB, outdoor temperature : 35°CDB, equivalent refrigerant piping : 8m, level difference : 0m.		
		Nominal heating capacities are based on : indoor temperature : 20°CDB, outdoor temperature : 7°CDB, 6°CWB, equivalent refrigerant piping : 8m, level difference : 0m.		
		Capacities are net, including a deduction for cooling (an addition for heating) for indoor fan motor heat.		

1-2 ELECTRICAL SPECIFICATIONS			FXCQ20MV3B	FXCQ25MV3B	FXCQ32MV3B	FXCQ40MV3B	FXCQ50MV3B
Power Supply	Name		V3				
	Phase		1	1	1	1	1
	Frequency	Hz	50	50	50	50	50
	Voltage	V	230	230	230	230	230
Current	Minimum circuit amps (MCA)	A	0.50	0.50	0.50	0.80	0.80
	Maximum fuse amps (MFA)	A	16.00	16.00	16.00	16.00	16.00
	Full load amps (FLA)	A	0.40	0.40	0.40	0.60	0.60
Voltage range	Minimum	V	-10%				
	Maximum	V	+10%				
Power Supply Intake			Both indoor and outdoor unit				
Notes			Voltage range: units are suitable for use on electrical systems where voltage supplied to unit terminals is not below or above listed range limits.				
			Maximum allowable voltage range variation between phases is 2%.				
			MCA/MFA : MCA = 1.25 × FLA				
			MFA <= 4 × FLA				
			select wire size based on the MCA				
			instead of a fuse, use a circuit breaker				
			For more details concerning conditional connections, see http://extranet.daikineurope.com , select "E-Data Books". Finally click on the document title of your choice.				

1-2 ELECTRICAL SPECIFICATIONS			FXCQ63MV3B	FXCQ80MV3B	FXCQ125MV3B
Power Supply	Name		V3		
	Phase		1	1	1
	Frequency	Hz	50	50	50
	Voltage	V	230	230	230
Current	Minimum circuit amps (MCA)	A	0.90	1.10	1.30
	Maximum fuse amps (MFA)	A	16.00	16.00	16.00
	Full load amps (FLA)	A	0.70	0.90	1.00
Voltage range	Minimum	V	-10%		
	Maximum	V	+10%		
Power Supply Intake			Both indoor and outdoor unit		
Notes			Voltage range : units are suitable for use on electrical systems where voltage supplied to unit terminals is not below or above listed range limits.		
			Maximum allowable voltage range variation between phases is 2%.		
			MCA/MFA : MCA = 1.25 × FLA		
			MFA <= 4 × FLA		
			select wire size based on the MCA		
			instead of a fuse, use a circuit breaker		
			For more details concerning conditional connections, see http://extranet.daikineurope.com , select "E-Data Books". Finally click on the document title of your choice.		

Ceiling Mounted Corner Cassette

1-1 TECHNICAL SPECIFICATIONS				FXKQ25MAVE	FXKQ32MAVE	FXKQ40MAVE	FXKQ63MAVE
Nominal Capacity	Cooling		kW	2.80	3.60	4.50	7.10
	Heating		kW	3.20	4.00	5.00	8.00
Power input (Nominal)	Cooling		kW	0.066	0.066	0.076	0.105
	Heating		kW	0.046	0.046	0.056	0.085
Casing	Material			Galvanised steel			
Dimensions	Unit	Height	mm	215	215	215	215
		Width	mm	1,110	1,110	1,110	1,310
		Depth	mm	710	710	710	710
Weight	Unit		kg	31	31	31	34
Heat Exchanger	Dimensions	Nr of Rows		2	2	2	3
		Fin Pitch	mm	1.75	1.75	1.75	1.75
		Face Area	m ²	0.180	0.180	0.180	0.226
		Nr of Stages		11	11	11	11
Fan	Type			Sirocco fan			
	Quantity			1	1	1	1
Air Flow Rate	Cooling	High	m ³ /min	11.00	11.00	13.00	18.00
		Low	m ³ /min	9.00	9.00	10.00	15.00
Fan	Motor	Quantity		1	1	1	1
		Model		3D12H1AN1V1	3D12H1AN1V1	3D12H1AP1V1	4D12H1AJ1V1
		Output (high)	W	15	15	20	45
		Drive			Direct drive		
Refrigerant	Name			R-410A			
Cooling	Sound Pressure	High	dBA	38.0	38.0	40.0	42.0
		Low	dBA	33.0	33.0	34.0	37.0
Piping connections	Liquid (OD)	Type		Flare connection			
		Diameter	mm	6.4	6.4	6.4	9.5
	Gas	Type		Flare connection			
		Diameter	mm	12.7	12.7	12.7	15.9
	Drain	Diameter	mm	32	32	32	32
Heat Insulation			Foamed Polyethylene				
Decoration Panel	Model			BYK45FJW1	BYK45FJW1	BYK45FJW1	BYK71FJW1
	Colour			White			
	Dimensions	Height	mm	70	70	70	70
		Width	mm	1,240	1,240	1,240	1,440
		Depth	mm	800	800	800	800
Weight		kg	8.5	8.5	8.5	9.5	
Air Filter	Resin net with mold resistance						
Refrigerant control	Electronic expansion valve						
Temperature control	Microprocessor thermostat for cooling and heating						
Safety devices	PC board fuse						
	Drain pump fuse						
	Fan motor thermal fuse			Fan motor thermal protector			
Standard Accessories	Installation and operation manual						
	Metal clamp for drain hose						
	Clamps						
	Insulation for hangar bracket						
	Positioning Jig for Installation						
	Paper pattern for installation						
	Drain hose						
	Insulation for fitting						
	Sealing Pads						
	Screws						
	Washer						
Air Outlet blocking pad							

1-1 TECHNICAL SPECIFICATIONS	FXKQ25MAVE	FXKQ32MAVE	FXKQ40MAVE	FXKQ63MAVE
Notes	Nominal cooling capacities are based on : indoor temperature : 27°CDB, 19°CWB, outdoor temperature : 35°CDB, equivalent refrigerant piping : 7.5m (horizontal)			
	Nominal heating capacities are based on: indoor temperature : 20°CDB, outdoor temperature : 7°CDB, 6°CWB, equivalent refrigerant piping : 7.5m (horizontal)			
	Capacities are net, including a deduction for cooling (an addition for heating) for indoor fan motor heat.			
	Sound pressure levels are measured at 220V			

1-2 ELECTRICAL SPECIFICATIONS			FXKQ25MAVE	FXKQ32MAVE	FXKQ40MAVE	FXKQ63MAVE
Power Supply	Name	VE				
	Phase		1	1	1	1
	Frequency	Hz	50	50	50	50
	Voltage	V	220-240			
Current	Minimum circuit amps (MCA)	A	0.30	0.30	0.30	0.50
	Maximum fuse amps (MFA)	A	15.00	15.00	15.00	15.00
	Full load amps (FLA)	A	0.20	0.20	0.20	0.40
Voltage range	Minimum	V	-10%			
	Maximum	V	+10%			
Notes	Voltage range : units are suitable for use on electrical systems where voltage supplied to unit terminals is not below or above listed range limits.					
	Maximum allowable voltage range variation between phases is 2%.					
	MCA/MFA : MCA = 1.25 × FLA					
	MFA <= 4 × FLA					
	next lower standard fuse rating minimum 15A					
	select wire size based on the MCA					
	instead of a fuse, use a circuit breaker					
For more details concerning conditional connections, see http://extranet.daikineurope.com , select "E-Data Books". Finally, click on the document title of your choice.						

Slim Concealed Ceiling Unit (with Drain Pump)

1-1 TECHNICAL SPECIFICATIONS				FXDQ20PVE	FXDQ25PVE	FXDQ32PVE	FXDQ40NAVE	FXDQ50NAVE	FXDQ63NAVE
Nominal Capacity	Cooling	kW		2.20	2.80	3.60	4.50	5.60	7.10
	Heating	kW		2.50	3.20	4.00	5.00	6.30	8.00
Power input (Nominal)	Cooling	kW		0.086	0.086	0.089	0.160	0.165	0.181
	Heating	kW		0.067	0.067	0.070	0.147	0.152	0.168
Casing	Material			Galvanised steel plate					
Dimensions	Unit	Height	mm	200	200	200	200	200	200
		Width	mm	700	700	700	900	900	1,100
		Depth	mm	620	620	620	620	620	620
Weight	Unit		kg	23.0	23.0	23.0	27.0	28.0	31.0
Heat Exchanger	Dimensions	Nr of Rows		2	2	3	3	3	3
		Fin Pitch	mm	1.50	1.50	1.50	1.50	1.50	1.50
		Face Area	m ²	0.126	0.126	0.126	0.176	0.176	0.227
		Nr of Stages		12	12	12	12	12	12
	Fin	Fin type			Cross fin coil				
Fan	Type			Sirocco fan					
	Quantity			1	1	1	1	1	1
Air Flow Rate	Cooling	High	m ³ /min	8.0	8.0	8.0	10.50	12.50	16.50
		Low	m ³ /min	6.4	6.4	6.4	8.50	10.00	13.00
Fan	External static pressure	High	Pa	30	30	30	44	44	44
		Standard	Pa	10	10	10	15	15	15
	Motor	Output (high)	W	62	62	62	62	130	130
		Drive			Direct drive				
Refrigerant	Name			R-410A					
Cooling	Sound Pressure	High	dBA	33.0	33.0	33.0	34.0	35.0	36.0
		Low	dBA	29.0	29.0	29.0	30.0	31.0	32.0
Piping connections	Liquid (OD)	Type		Flare connection					
		Diameter	mm	6.4	6.4	6.4	6.4	6.4	9.5
	Gas	Type		Flare connection					
		Diameter	mm	12.7	12.7	12.7	12.7	12.7	15.9
Drain	Diameter		VP20 (I.D. 20/O.D. 26)						
Air Filter				Removable/washable/Mildew proof					
Refrigerant control				Electronic expansion valve					
Temperature control				Microprocessor thermostat for cooling and heating					
Safety devices				Fuse					
				Fan motor thermal protector					
Standard Accessories	Standard Accessories			Installation and operation manual					
				Drain hose					
				Sealing Pads					
				Clamps					
				Washer					
				Insulation for fitting					
				Clamp metal					
				Washer fixing plate					
				Screws for duct flanges					
				Air filter					
Notes				Nominal cooling capacities are based on : indoor temperature : 27°CDB, 19°CWB, outdoor temperature : 35°CDB, equivalent refrigerant piping : 7.5m (horizontal)					
				Nominal heating capacities are based on : indoor temperature : 20°CDB, outdoor temperature : 7°CDB, 6°CWB, equivalent refrigerant piping : 7.5m (horizontal)					
				Capacities are net, including a deduction for cooling (an addition for heating) for indoor fan motor heat.					
				External static pressure can be changed by the remote control.					
				The operation sound levels are conversion values in anechoic chamber. In practice, sound levels tend to be higher than the specified values due to ambient noise or reflection. When the suction place is changed to bottom suction, sound level will increase by approximately 5dBA.					

Slim Concealed Ceiling Unit (with Drain Pump)

1-2 ELECTRICAL SPECIFICATIONS			FXDQ20PVE	FXDQ25PVE	FXDQ32PVE	FXDQ40NAVE	FXDQ50NAVE	FXDQ63NAVE
Power Supply	Name		VE					
	Phase		1	1	1	1	1	1
	Frequency	Hz	50	50	50	50	50	50
	Voltage	V	220-240					
Current	Minimum circuit amps (MCA)	A	0.80	0.80	0.80	1.00	1.00	1.10
	Maximum fuse amps (MFA)	A	15.00	15.00	15.00	15.00	15.00	15.00
	Full load amps (FLA)	A	0.60	0.60	0.60	0.80	0.80	0.90
Voltage range	Minimum	V	-10%					
	Maximum	V	+10%					
Notes			Voltage range : units are suitable for use on electrical systems where voltage supplied to unit terminals is not below or above listed range limits.					
			Maximum allowable voltage range variation between phases is 2%.					
			MCA/MFA : MCA = 1.25 × FLA					
			MFA ≤ 4 × FLA					
			next lower standard fuse rating minimum 15A					
			select wire size based on the MCA					
			instead of a fuse, use a circuit breaker					
			For more details concerning conditional connections, see http://extranet.daikineurope.com , select "E-Data Books". Finally, click on the document title of your choice.					

Concealed Ceiling Unit (Small)

1-1 TECHNICAL SPECIFICATIONS				FXDQ20MV3B		FXDQ25MV3B		
Nominal Capacity	Cooling		kW	2.20		2.80		
	Heating		kW	2.50		3.20		
Power input (Nominal)	Cooling		kW	0.050		0.050		
	Heating		kW	0.050		0.050		
Casing	Colour			Non painted				
	Material			Galvanised steel				
Dimensions	Packing	Height	mm	301		301		
		Width	mm	584		584		
		Depth	mm	753		753		
	Unit	Height	mm	230		230		
		Width	mm	502		502		
		Depth	mm	652		652		
Weight	Unit		kg	17		17		
	Packed unit		kg	18		18		
Required Ceiling Void			mm	250		250		
Heat Exchanger	Dimensions	Length	mm	430		430		
		Nr of Rows			2		2	
		Fin Pitch	mm	1.40		1.40		
		Nr of Passes			2		2	
		Face Area	m ²	0.108		0.108		
		Nr of Stages			12		12	
	Empty Tubeplate Hole			4				
	Tube type			Hi-XSS (7)				
Fin	Fin type			Symmetric waffle louvre				
	Treatment			Hydrophilic				
Fan	Type			Sirocco fan				
	Quantity			1		1		
Air Flow Rate	Cooling	High	m ³ /min	6.70		7.40		
		Low	m ³ /min	5.20		5.80		
	Heating	High	m ³ /min	6.70		7.40		
		Low	m ³ /min	5.20		5.80		
Fan	Motor	Quantity		1		1		
		Steps		step motor				
	Output (high)	W	10		10			
	Drive			Direct drive				
Refrigerant	Name			R-410A				
Sound Level	Cooling	Sound power (nominal)	dBa	50.0		50.0		
Cooling	Sound Pressure	High	dBa	37.0		37.0		
		Low	dBa	32.0		32.0		
Heating	Sound Pressure	High	dBa	37.0		37.0		
		Low	dBa	32.0		32.0		
Piping connections	Liquid (OD)	Type		Flare connection				
		Diameter	mm	6.4		6.4		
	Gas	Type		Flare connection				
		Diameter	mm	12.7		12.7		
Drain	Diameter	mm	27.2		27.2			
Air Filter				Resin net with mold resistance				
Air direction control				Up and downwards				
Refrigerant control				Electronic expansion valve				
Temperature control				Microprocessor thermostat for cooling and heating				
Safety devices				PC board fuse				
				Fan motor thermal protector				

1-1 TECHNICAL SPECIFICATIONS		FXDQ20MV3B	FXDQ25MV3B
Standard Accessories	Standard Accessories	Installation and operation manual	
		Fuse	
		Caution for servicing sticker	
		Suction air filter	
Notes		Nominal cooling capacities are based on : indoor temperature : 27°CDB, 19°CWB, outdoor temperature : 35°CDB, equivalent refrigerant piping : 8m, level difference : 0m.	
		Nominal heating capacities are based on : indoor temperature : 20°CDB, outdoor temperature : 7°CDB, 6°CWB, equivalent refrigerant piping : 8m, level difference : 0m.	
		Capacities are net, including a deduction for cooling (an addition for heating) for indoor fan motor heat.	

1-2 ELECTRICAL SPECIFICATIONS			FXDQ20MV3B	FXDQ25MV3B
Power Supply	Name		V1	
	Phase		1	1
	Frequency	Hz	50	50
	Voltage	V	230	230
Current	Minimum circuit amps (MCA)	A	0.20	0.20
	Maximum fuse amps (MFA)	A	16.00	16.00
	Full load amps (FLA)	A	0.10	0.10
Voltage range	Minimum	V	-10%	
	Maximum	V	+10%	
Power Supply Intake			Both indoor and outdoor unit	
Notes			Voltage range : units are suitable for use on electrical systems where voltage supplied to unit terminals is not below or above listed range limits.	
			Maximum allowable voltage range variation between phases is 2%.	
			MCA/MFA : MCA = 1.25 × FLA	
			MFA < 4 × FLA	
			next lower standard fuse rating minimum 16A	
			select wire size based on the MCA	
			instead of a fuse, use a circuit breaker	
			For more details concerning conditional connections, see http://extranet.daikineurope.com , select "E-Data Books". Finally, click on the document title of your choice.	

Concealed Ceiling Unit

1-1 TECHNICAL SPECIFICATIONS				FXSQ20MV3B	FXSQ25MV3B	FXSQ32MV3B	FXSQ40MV3B	FXSQ50MV3B	
Capacity (Conditions specified in 1)	Cooling		kW	2.20	2.80	3.60	4.50	5.60	
	Heating		kW	2.50	3.20	4.00	5.00	6.30	
Power input (Nominal)	Cooling		kW	0.110	0.110	0.114	0.127	0.143	
	Heating		kW	0.090	0.090	0.094	0.107	0.123	
Casing	Colour			Non painted					
	Material			Galvanised steel					
Dimensions	Packing	Height	mm	354	354	354	354	354	
		Width	mm	742	742	742	892	892	
		Depth	mm	936	936	936	936	936	
	Unit	Height	mm	300	300	300	300	300	
		Width	mm	550	550	550	700	700	
		Depth	mm	800	800	800	800	800	
Weight	Unit		kg	30	30	30	30	31	
	Packed Unit		kg	34	34	34	34	35	
Required Ceiling Void			mm	350	350	350	350	350	
Heat Exchanger	Dimensions	Length	mm	300	300	300	450	450	
		Nr of Rows			3	3	3	3	3
		Fin Pitch	mm	1.75	1.75	1.75	1.75	1.75	
		Nr of Passes			3	3	3	4	4
		Face Area	m ²	0.088	0.088	0.088	0.132	0.132	
		Nr of Stages			14	14	14	14	14
	Empty Tubeplate Hole			14					
	Tube type			Hi-XSS (7)					
	Fin	Fin type		Symmetric waffle louvre					
		Treatment		Hydrophilic					
Fan	Type			Sirocco fan					
	Quantity			1	1	1	1	1	
Air Flow Rate	Cooling	High	m ³ /min	9.00	9.00	9.50	11.50	15.00	
		Low	m ³ /min	6.50	6.50	7.00	9.00	11.00	
	Heating	High	m ³ /min	9.00	9.00	9.50	11.50	15.00	
		Low	m ³ /min	6.50	6.50	7.00	9.00	11.00	
Fan	External static pressure	High	Pa	125	125	104	116	136	
		Standard	Pa	105	105	88	98	114	
		Low	Pa	96	96	78	85	99	
	Motor	Quantity			1	1	1	1	1
		Model			D18H3AA1V1	D18H3AA1V1	D18H3AA1V1	D18H2AC1V1	D18H2AB1V1
		Steps			step motor				
		Output (high)	W	50	50	50	65	85	
	Drive			Direct drive					
Refrigerant	Name			R-410A					
Sound Level	Cooling	Sound power (nominal)	dBA	50.0	50.0	51.0	56.0	58.0	
		Sound Pressure	High	dBA	32.0	32.0	33.0	33.0	35.0
Heating	Low		dBA	28.0	28.0	28.0	29.0	31.0	
	Sound Pressure	High	dBA	32.0	32.0	33.0	33.0	35.0	
Low		dBA	28.0	28.0	28.0	29.0	31.0		
Piping connections	Liquid (OD)	Type		Flare connection					
		Diameter	mm	6.35	6.35	6.35	6.35	6.35	
	Gas	Type		Flare connection					
		Diameter	mm	12.7	12.7	12.7	12.7	12.7	
	Drain	Diameter	mm	32	32	32	32	32	
	Heat Insulation			Both liquid and gas pipes					

Concealed Ceiling Unit

1-1 TECHNICAL SPECIFICATIONS			FXSQ20MV3B	FXSQ25MV3B	FXSQ32MV3B	FXSQ40MV3B	FXSQ50MV3B	
Decoration Panel	Model		BYBS32DJW1	BYBS32DJW1	BYBS32DJW1	BYBS45DJW1	BYBS45DJW1	
	Colour		White (10Y9/0,5)					
	Dimensions	Height	mm	55	55	55	55	55
		Width	mm	650	650	650	800	800
		Depth	mm	500	500	500	500	500
Weight		kg	3	3	3	3.5	3.5	
Drain-up Height		mm	600	600	600	600	600	
Air Filter		Resin net with mold resistance						
Air direction control		Up and downwards						
Refrigerant control		Electronic expansion valve						
Temperature control		Microprocessor thermostat for cooling and heating						
Safety devices		PC board fuse						
		Drain pump fuse						
		Fan motor thermal fuse						
Standard Accessories	Standard Accessories		Metal clamp for drain hose					
	Quantity		1	1	1	1	1	
	Standard Accessories		Paper pattern for installation					
	Quantity		1	1	1	1	1	
	Standard Accessories		Drain hose					
	Quantity		1	1	1	1	1	
	Standard Accessories		Insulation for fitting					
	Quantity		2	2	2	2	2	
	Standard Accessories		Washer for hanger bracket					
	Quantity		8	8	8	8	8	
	Standard Accessories		Screws for duct flanges					
	Quantity		6	6	6	8	8	
	Standard Accessories		Screws for fixing the paper pattern for installation					
	Quantity		6	6	6	6	6	
	Standard Accessories		Fuse					
Quantity		Installation and operation manual						
Quantity		1	1	1	1	1		
Notes		Nominal cooling capacities are based on : indoor temperature : 27°CDB, 19°CWB, outdoor temperature : 35°CDB, equivalent refrigerant piping : 8m, level difference : 0m.						
		Nominal heating capacities are based on : indoor temperature : 20°CDB, outdoor temperature : 7°CDB, 6°CWB, equivalent refrigerant piping : 8m, level difference : 0m.						
		The external static pressure is changeable : change the connectors inside the electrical box, this pressure means : High static pressure-standard-low static pressure						
		The external static pressure is changeable : change the connectors inside the electrical box, this pressure means : High static pressure-standard						
		Capacities are net, including a deduction for cooling (an addition for heating) for indoor fan motor heat.						
		The sound pressure values are mentioned for a unit installed with rear suction						

Concealed Ceiling Unit

1-1 TECHNICAL SPECIFICATIONS				FXSQ63MV3B	FXSQ80MV3B	FXSQ100MV3B	FXSQ125MV3B	
Capacity (Conditions specified in 1)	Cooling		kW	7.10	9.00	11.20	14.00	
	Heating		kW	8.00	10.00	12.50	16.00	
Power input (Nominal)	Cooling		kW	0.189	0.234	0.242	0.321	
	Heating		kW	0.169	0.214	0.222	0.301	
Casing	Colour	Non painted						
	Material	Galvanised steel						
Dimensions	Packing	Height	mm	354	356	356	356	
		Width	mm	1,192	1,596	1,596	1,596	
		Depth	mm	936	938	938	938	
	Unit	Height	mm	300	300	300	300	
		Width	mm	1,000	1,400	1,400	1,400	
		Depth	mm	800	800	800	800	
Weight	Unit		kg	41	51	51	52	
	Packed Unit		kg	47	58	58	59	
Required Ceiling Void			mm	350	350	350	350	
Heat Exchanger	Dimensions	Length	mm	750	1,150	1,150	1,150	
		Nr of Rows		3	3	3	3	
		Fin Pitch	mm	1.75	1.75	1.75	1.75	
		Nr of Passes		7	10	10	10	
		Face Area	m ²	0.221	0.338	0.338	0.338	
		Nr of Stages		14	14	14	14	
	Tube type	Hi-XSS (7)						
Fin	Fin type	Symmetric waffle louvre						
	Treatment	Hydrophilic						
Fan	Type	Sirocco fan						
	Quantity			2	3	3	3	
Air Flow Rate	Cooling	High	m ³ /min	21.00	27.00	28.00	38.00	
		Low	m ³ /min	15.50	20.00	20.50	28.00	
	Heating	High	m ³ /min	21.00	27.00	28.00	38.00	
		Low	m ³ /min	15.50	20.00	20.50	28.00	
Fan	External static pressure	High	Pa	123	141	141	109	
		Standard	Pa	111	125	125	93	
		Low	Pa	98				
		Motor	Quantity		1	1	1	1
	Model			2D18H2AB1V1	3D18H2AH1V1	3D18H2AH1V1	3D18H2AG1V1	
	Steps		step motor					
	Output (high)	W		125	135	135	225	
Drive	Direct drive							
Refrigerant	Name	R-410A						
Sound Level	Cooling	Sound power (nominal)	dBa	56.0	55.0	56.0	65.0	
Cooling	Sound Pressure	High	dBa	35.0	37.0	38.0	40.0	
		Low	dBa	30.0	31.0	33.0	35.0	
Heating	Sound Pressure	High	dBa	35.0	37.0	38.0	40.0	
		Low	dBa	30.0	31.0	33.0	35.0	
Piping connections	Liquid (OD)	Type	Flare connection					
		Diameter	mm	9.5	9.5	9.5	9.5	
	Gas	Type	Flare connection					
		Diameter	mm	15.9	15.9	15.9	15.9	
	Drain	Diameter	mm	32	32	32	32	
Heat Insulation	Both liquid and gas pipes							

1-1 TECHNICAL SPECIFICATIONS			FXSQ63MV3B	FXSQ80MV3B	FXSQ100MV3B	FXSQ125MV3B	
Decoration Panel	Model		BYBS71DJW1	BYBS125DJW1	BYBS125DJW1	BYBS125DJW1	
	Colour		White (10Y9/0,5)				
	Dimensions	Height	mm	55	55	55	55
		Width	mm	1,100	1,500	1,500	1,500
		Depth	mm	500	500	500	500
	Weight	kg	4.5	6.5	6.5	6.5	
Drain-up Height		mm	600	600	600	600	
Air Filter			Resin net with mold resistance				
Air direction control			Up and downwards				
Refrigerant control			Electronic expansion valve				
Temperature control			Microprocessor thermostat for cooling and heating				
Safety devices			PC board fuse				
			Drain pump fuse				
			Fan motor thermal fuse	Fan motor thermal protector	Fan motor thermal protector	Fan motor thermal protector	
Standard Accessories	Standard Accessories		Metal clamp for drain hose				
	Quantity		1	1	1	1	
	Standard Accessories		Paper pattern for installation				
	Quantity		1	1	1	1	
	Standard Accessories		Drain hose				
	Quantity		1	1	1	1	
	Standard Accessories		Insulation for fitting				
	Quantity		2	2	2	2	
	Standard Accessories		Washer for hanger bracket				
	Quantity		8	8	8	8	
	Standard Accessories		Screws for duct flanges				
	Quantity		12	16	16	16	
	Standard Accessories		Screws for fixing the paper pattern for installation				
	Quantity		6	6	6	6	
Standard Accessories		Fuse					
Quantity		1	1	1	1		
Notes			Nominal cooling capacities are based on : indoor temperature : 27°CDB, 19°CWB, outdoor temperature : 35°CDB, equivalent refrigerant piping : 8m, level difference : 0m.				
			Nominal heating capacities are based on : indoor temperature : 20°CDB, 19°CWB, outdoor temperature : 7°CDB, 6°CWB, equivalent refrigerant piping : 8m, level difference : 0m.				
			The external static pressure is changeable : change the connectors inside the electrical box, this pressure means : High static pressure - standard - low static pressure				
			The external static pressure is changeable : change the connectors inside the electrical box, this pressure means : High static pressure - standard				
			Capacities are net, including a deduction for cooling (an addition for heating) for indoor fan motor heat.				
			The sound pressure values are mentioned for a unit installed with rear suction				

1-2 ELECTRICAL SPECIFICATIONS			FXSQ20MV3B	FXSQ25MV3B	FXSQ32MV3B	FXSQ40MV3B	FXSQ50MV3B
Power Supply	Name		V3				
	Phase		1	1	1	1	1
	Frequency	Hz	50	50	50	50	50
	Voltage	V	230	230	230	230	230
Current	Minimum circuit amps (MCA)	A	0.50	0.50	0.50	0.60	0.90
	Maximum fuse amps (MFA)	A	16.00	16.00	16.00	16.00	16.00
	Full load amps (FLA)	A	0.40	0.40	0.40	0.50	0.70
Voltage range	Minimum	V	-10%				
	Maximum	V	+10%				
Notes			Voltage range: units are suitable for use on electrical systems where voltage supplied to unit terminals is not below or above listed range limits.				
			Maximum allowable voltage range variation between phases is 2%				
			MCA/MFA : MCA = 1.25 × FLA				
			MFA < 4 × FLA				
			next lower standard fuse rating minimum 16A				
			select wire size based on the MCA				
			instead of a fuse, use a circuit breaker				
			For more details concerning conditional connections, see http://extranet.daikineurope.com , select "E-Data Books". Finally, click on the document title of your choice.				

1-2 ELECTRICAL SPECIFICATIONS			FXSQ63MV3B	FXSQ80MV3B	FXSQ100MV3B	FXSQ125MV3B
Power Supply	Name		V3			
	Phase		1	1	1	1
	Frequency	Hz	50	50	50	50
	Voltage	V	230	230	230	230
Current	Minimum circuit amps (MCA)	A	1.10	1.40	1.50	2.00
	Maximum fuse amps (MFA)	A	16.00	16.00	16.00	16.00
	Full load amps (FLA)	A	0.90	1.10	1.20	1.60
Voltage range	Minimum	V	-10%			
	Maximum	V	+10%			
Notes			Voltage range : units are suitable for use on electrical systems where voltage supplied to unit terminals is not below or above listed range limits.			
			Maximum allowable voltage range variation between phases is 2%.			
			MCA/MFA : MCA = 1.25 × FLA			
			MFA < 4 × FLA			
			next lower standard fuse rating minimum 16A			
			select wire size based on the MCA			
			instead of a fuse, use a circuit breaker			
			For more details concerning conditional connections, see http://extranet.daikineurope.com , select "E-Data Books". Finally, click on the document title of your choice.			

Concealed Ceiling Unit (Large)

1-1 TECHNICAL SPECIFICATIONS				FXMQ40MAVE	FXMQ50MAVE	FXMQ63MAVE	FXMQ80MAVE
Nominal Capacity	Cooling		kW	4.50	5.60	7.10	9.00
	Heating		kW	5.00	6.30	8.00	10.00
Power input (Nominal)	Cooling		kW	0.211	0.211	0.211	0.284
	Heating		kW	0.211	0.211	0.211	0.284
Casing	Material			Galvanised steel			
Dimensions	Unit	Height	mm	390	390	390	390
		Width	mm	720	720	720	720
		Depth	mm	690	690	690	690
Weight	Unit		kg	44	44	44	45
Heat Exchanger	Dimensions	Nr of Rows		3	3	3	3
		Fin Pitch	mm	2.00	2.00	2.00	2.00
		Face Area	m ²	0.181	0.181	0.181	0.181
		Nr of Stages		16	16	16	16
Fan	Type			Sirocco fan			
	Quantity			1	1	1	1
Air Flow Rate	Cooling	High	m ³ /min	14.00	14.00	14.00	19.50
		Low	m ³ /min	11.50	11.50	11.50	16.00
Fan	External static pressure	High	Pa	157	157	157	157
		Standard	Pa	118	118	118	108
	Motor	Quantity		1	1	1	1
		Model		D11/2D3AB1VE	D11/2D3AB1VE	D11/2D3AB1VE	D11/2D3AA1VE
		Output (high)	W	100	100	100	160
		Drive			Direct drive		
Refrigerant	Name			R-410A			
Cooling	Sound Pressure	High	dB(A)	39.0	39.0	39.0	42.0
		Low	dB(A)	35.0	35.0	35.0	38.0
Piping connections	Liquid (OD)	Type		Flare connection			
		Diameter	mm	6.4	6.4	9.5	9.5
	Gas	Type		Flare connection			
		Diameter	mm	12.7	12.7	15.9	15.9
	Drain	Diameter	mm	32	32	32	32
Heat Insulation			Glass fiber				
Refrigerant control			Electronic expansion valve				
Temperature control			Microprocessor thermostat for cooling and heating				
Safety devices			PC board fuse				
			Fan motor thermal protector				
Standard Accessories	Standard Accessories			Installation and operation manual			
				Drain hose			
				Sealing Pads			
				Clamps			
				Screws			
				Insulation for fitting			
				Clamp metal			
				Notes			Nominal cooling capacities are based on : indoor temperature : 27°CDB, 19°CWB, outdoor temperature : 35°CDB, equivalent refrigerant piping : 7.5m (horizontal)
			Nominal heating capacities are based on : indoor temperature : 20°CDB, outdoor temperature : 7°CDB, 6°CWB, equivalent refrigerant piping : 7.5m (horizontal)				
			Capacities are net, including a deduction for cooling (an addition for heating) for indoor fan motor heat.				
			The external static pressure is changeable : change the connectors inside the electrical box, this pressure means : High static pressure-standard				
			Air filter is not standard accessory, but please mount it in the duct system of the suction side. Select its colorimetric method (gravity method) 50% or more.				
			Sound pressure levels are measured at 220V				

Concealed Ceiling Unit (Large)

1-1 TECHNICAL SPECIFICATIONS				FXMQ100MAVE	FXMQ125MAVE	FXMQ200MAVE	FXMQ250MAVE
Nominal Capacity	Cooling	kW		11.20	14.00	22.40	28.00
	Heating	kW		12.50	16.00	25.00	31.50
Power input (Nominal)	Cooling	kW		0.411	0.619	1.294	1.465
	Heating	kW		0.411	0.619	1.294	1.465
Casing	Material			Galvanised steel			
Dimensions	Unit	Height	mm	390	390	470	470
		Width	mm	1,110	1,110	1,380	1,380
		Depth	mm	690	690	1,100	1,100
Weight	Unit		kg	63	65	137	137
Heat Exchanger	Dimensions	Nr of Rows		3	3	3	3
		Fin Pitch	mm	2.00	2.00	2.00	2.00
		Face Area	m ²	0.319	0.319	0.68	0.68
		Nr of Stages		16	16	26	26
Fan	Type			Sirocco fan			
	Quantity			1	1	2	2
Air Flow Rate	Cooling	High	m ³ /min	29.00	36.00	58.00	72.00
		Low	m ³ /min	23.00	29.00	50.00	62.00
Fan	External static pressure	High	Pa	157	191	221	270
		Standard	Pa	98	152	132	147
	Motor	Quantity		1	1	2	2
		Model		2D11/2D3AG1VE	2D11/2D3AF1VE	D13/4G2DA1	D13/4G2DA1
		Output (high)	W	270	430	380	380
		Drive			Direct drive		
Refrigerant	Name			R-410A			
Cooling	Sound Pressure	High	dBA	43.0	45.0	48.0	48.0
		Low	dBA	39.0	42.0	45.0	45.0
Piping connections	Liquid (OD)	Type		Flare connection			
		Diameter	mm	9.5	9.5	9.5	9.5
	Gas	Type		Flare connection	Flare connection	Braze connection	Braze connection
		Diameter	mm	15.9	15.9	19.1	22.2
	Drain	Diameter	mm	32	32	PS1B	PS1B
Heat Insulation			Glass fiber				
Refrigerant control			Electronic expansion valve				
Temperature control			Microprocessor thermostat for cooling and heating				
Safety devices			PC board fuse				
			Fan motor thermal protector				
Standard Accessories	Standard Accessories			Installation and operation manual			
				Drain hose		Connection pipes	
				Sealing Pads			
				Clamps			
				Screws			
				Insulation for fitting			
				Clamp metal			
				Notes			Nominal cooling capacities are based on : indoor temperature : 27°CDB, 19°CWB, outdoor temperature : 35°CDB, equivalent refrigerant piping : 7.5m (horizontal)
			Nominal heating capacities are based on : indoor temperature : 20°CDB, outdoor temperature : 7°CDB, 6°CWB, equivalent refrigerant piping : 7.5m (horizontal)				
			Capacities are net, including a deduction for cooling (an addition for heating) for indoor fan motor heat.				
			The external static pressure is changeable : change the connectors inside the electrical box, this pressure means : High static pressure-standard				
			Air filter is not standard accessory, but please mount it in the duct system of the suction side. Select its colorimetric method (gravity method) 50% or more.				
			Sound pressure levels are measured at 220V				
			FXMQ200, 250MAVE cannot be connected to VRVIII-S				

1-2 ELECTRICAL SPECIFICATIONS			FXMQ40MAVE	FXMQ50MAVE	FXMQ63MAVE	FXMQ80MAVE
Power Supply	Name		VE			
	Phase		1	1	1	1
	Frequency	Hz	50	50	50	50
	Voltage		220-240			
Current	Minimum circuit amps (MCA)	A	1.30	1.30	1.30	1.50
	Maximum fuse amps (MFA)	A	15.00	15.00	15.00	15.00
	Full load amps (FLA)	A	1.00	1.00	1.00	1.20
Voltage range	Minimum	V	-10%			
	Maximum	V	+10%			
Notes			Voltage range : units are suitable for use on electrical systems where voltage supplied to unit terminals is not below or above listed range limits.			
			Maximum allowable voltage rang variation between phases is 2%.			
			MCA/MFA : MCA = 1.25 × FLA			
			MFA <= 4 × FLA			
			next lower standard fuse rating minimum 15A			
			select wire size based on the MCA			
			instead of a fuse, use a circuit breaker			
			For more details concerning conditional connections, see http://extranet.daikineurope.com , select "E-Data Books". Finally, click on the document title of your choice.			

1-2 ELECTRICAL SPECIFICATIONS			FXMQ100MAVE	FXMQ125MAVE	FXMQ200MAVE	FXMQ250MAVE
Power Supply	Name		VE			
	Phase		1	1	1	1
	Frequency	Hz	50	50	50	50
	Voltage		220-240			
Current	Minimum circuit amps (MCA)	A	2.50	3.80	8.10	9.00
	Maximum fuse amps (MFA)	A	15.00	15.00	15.00	15.00
	Full load amps (FLA)	A	2.00	3.00	6.50	7.20
Voltage range	Minimum	V	-10%			
	Maximum	V	+10%			
Notes			Voltage range : units are suitable for use on electrical systems where voltage supplied to unit terminals is not below or above listed range limits.			
			Maximum allowable voltage range variation between phases is 2%.			
			MCA/MFA : MCA = 1.25 × FLA			
			MFA <= 4 × FLA			
			next lower standard fuse rating minimum 15A			
			select wire size based on the MCA			
			instead of a fuse, use a circuit breaker			
			For more details concerning conditional connections, see http://extranet.daikineurope.com , select "E-Data Books". Finally, click on the document title of your choice.			

Ceiling Suspended Unit

1-1 TECHNICAL SPECIFICATIONS				FXHQ32MAVE	FXHQ63MAVE	FXHQ100MAVE
Nominal Capacity	Cooling		kW	3.60	7.10	11.20
	Heating		kW	4.00	8.00	12.50
Power input (Nominal)	Cooling		kW	0.111	0.115	0.135
	Heating		kW	0.111	0.115	0.135
Casing	Colour			White (10Y9/0.5)		
Dimensions	Unit	Height	mm	195	195	195
		Width	mm	960	1,160	1,400
		Depth	mm	680	680	680
Weight	Unit		kg	24	28	33
Heat Exchanger	Dimensions	Nr of Rows		2	3	3
		Fin Pitch	mm	1.75	1.75	1.75
		Face Area	m ²	0.182	0.233	0.293
		Nr of Stages		12	12	12
Fan	Type			Sirocco fan		
	Quantity			1	1	1
Air Flow Rate	Cooling	High	m ³ /min	12.00	17.50	25.00
		Low	m ³ /min	10.00	14.00	19.50
Fan	Motor	Quantity		1	1	1
		Model		3D12K1AA1	4D12K1AA1	3D12K2AA1
		Output (high)	W	62	62	130
		Drive			Direct drive	
Refrigerant	Name			R-410A		
Cooling	Sound Pressure	High	dBA	36.0	39.0	45.0
		Low	dBA	31.0	34.0	37.0
Piping connections	Liquid (OD)	Type		Flare connection		
		Diameter	mm	6.4	9.5	9.5
	Gas	Type		Flare connection		
		Diameter	mm	12.7	15.9	15.9
	Drain	Diameter	mm	26	26	26
Heat Insulation			Glass wool			
Air Filter				Resin net with mold resistance		
Refrigerant control				Electronic expansion valve		
Temperature control				Microprocessor thermostat for cooling and heating		
Safety devices				PC board fuse		
				Fan motor thermal protector		
Standard Accessories	Standard Accessories			Installation and operation manual		
				Drain hose		
				Paper pattern for installation		
				Clamp metal		
				Insulation for fitting		
				Clamps		
				Washer		
Notes				Nominal cooling capacities are based on : indoor temperature : 27°CDB, 19°CWB, outdoor temperature : 35°CDB, equivalent refrigerant piping : 7.5m (horizontal)		
				Nominal heating capacities are based on : indoor temperature : 20°CDB, outdoor temperature : 7°CDB, 6°CWB, equivalent refrigerant piping : 7.5m (horizontal)		
				Capacities are net, including a deduction for cooling (an addition for heating) for indoor fan motor heat.		

1-2 ELECTRICAL SPECIFICATIONS			FXHQ32MAVE	FXHQ63MAVE	FXHQ100MAVE
Power Supply	Name		VE		
	Phase		1	1	1
	Frequency	Hz	50	50	50
	Voltage		220-240		
Current	Minimum circuit amps (MCA)	A	0.80	0.80	0.90
	Maximum fuse amps (MFA)	A	15.00	15.00	15.00
	Full load amps (FLA)	A	0.60	0.60	0.70
Voltage range	Minimum	V	-10%		
	Maximum	V	+10%		
Notes			Voltage range : units are suitable for use on electrical systems where voltage supplied to unit terminals is not below or above listed range limits.		
			Maximum allowable voltage range variation between phases is 2%		
			MCA/MFA : MCA = 1.25 × FLA		
			MFA ≤ 4 × FLA		
			next lower standard fuse rating minimum 15A		
			select wire size based on the MCA		
			instead of a fuse, use a circuit breaker		
			For more details concerning conditional connections, see http://extranet.daikineurope.com , select "E-Data Books". Finally, click on the document title of your choice.		

Wall Mounted Unit

1-1 TECHNICAL SPECIFICATIONS			FXAQ20MAVE	FXAQ25MAVE	FXAQ32MAVE	FXAQ40MAVE	FXAQ50MAVE	FXAQ63MAVE	
Nominal Capacity	Cooling	kW	2.20	2.80	3.60	4.50	5.60	7.10	
	Heating	kW	2.50	3.20	4.00	5.00	6.30	8.00	
Power input (Nominal)	Cooling	kW	0.016	0.022	0.027	0.020	0.027	0.050	
	Heating	kW	0.024	0.027	0.032	0.020	0.032	0.060	
Casing	Colour	white (3.0Y8.5/0.5)							
Dimensions	Unit	Height	mm	290	290	290	290	290	
		Width	mm	795	795	795	1,050	1,050	
		Depth	mm	230	230	230	230	230	
Weight	Unit	kg	11	11	11	14	14	14	
Heat Exchanger	Dimensions	Nr of Rows		2	2	2	2	2	
		Fin Pitch	mm	1.40	1.40	1.40	1.40	1.40	
		Face Area	m ²	0.161	0.161	0.161	0.213	0.213	
		Nr of Stages		14	14	14	14	14	
Fan	Type		Cross flow fan						
	Quantity		1	1	1	1			
Air Flow Rate	Cooling	High	m ³ /min	7.50	8.00	9.00	12.00	15.00	
		Low	m ³ /min	4.50	5.00	5.50	9.00	12.00	
Fan	Motor	Quantity		1	1	1	1	1	
		Model		QCL9661M	QCL9661M	QCL9661M	QCL9686M	QCL9686M	
		Output (high)	W	40	40	40	43	43	
		Drive		Direct drive					
Refrigerant	Name		R-410A						
Cooling	Sound Pressure	High	dBA	35.0	36.0	37.0	39.0	42.0	
		Low	dBA	29.0	29.0	29.0	34.0	36.0	
Piping connections	Liquid (OD)	Type		Flare connection					
		Diameter	mm	6.4	6.4	6.4	6.4	6.35	
	Gas	Type		Flare connection					
		Diameter	mm	12.7	12.7	12.7	12.7	12.7	
	Drain	Diameter	mm	18	18	18	18	18	
Heat Insulation		Foamed polystyrene/polyethylene							
Air Filter			Washable resin net						
Refrigerant control			Electronic expansion valve						
Temperature control			Microprocessor thermostat for cooling and heating						
Safety devices			PC board fuse						
Standard Accessories	Standard Accessories		Installation and operation manual						
			Installation panel						
			Paper pattern for installation						
			Insulation tape						
			Clamps						
			Screws						
Notes			Nominal cooling capacities are based on : indoor temperature : 27°CDB, 19°CWB, outdoor temperature : 35°CDB, equivalent refrigerant piping : 5m (horizontal)						
			Nominal heating capacities are based on : indoor temperature : 20°CDB, outdoor temperature : 7°CDB, 6°CWB, equivalent refrigerant piping : 5m (horizontal)						
			Capacities are net, including a deduction for cooling (an addition for heating) for indoor fan motor heat.						

Wall Mounted Unit

1-2 ELECTRICAL SPECIFICATIONS			FXAQ20MAVE	FXAQ25MAVE	FXAQ32MAVE	FXAQ40MAVE	FXAQ50MAVE	FXAQ63MAVE
Power Supply	Name		VE					
	Phase		1	1	1	1	1	1
	Frequency	Hz	50	50	50	50	50	50
	Voltage	V	220-240					
Current	Minimum circuit amps (MCA)	A	0.30	0.40	0.40	0.40	0.40	0.60
	Maximum fuse amps (MFA)	A	15.00	15.00	15.00	15.00	15.00	15.00
	Full load amps (FLA)	A	0.20	0.30	0.30	0.30	0.30	0.50
Voltage range	Minimum	V	-10%					
	Maximum	V	+10%					
Notes			Voltage range : units are suitable for use on electrical systems where voltage supplied to unit terminals is not below or above listed range limits.					
			Maximum allowable voltage range variation between phases is 2%.					
			MCA/MFA : $MCA = 1.25 \times FLA$					
			$MFA \leq 4 \times FLA$					
			next lower standard fuse rating minimum 15A					
			select wire size based on the MCA					
			instead of a fuse, use a circuit breaker					
			For more details concerning conditional connections, see http://extranet.daikineurope.com , select "E-Data Books". Finally, click on the document title of your choice.					

Floor Standing Unit

1-1 TECHNICAL SPECIFICATIONS				FXLQ20MAVE	FXLQ25MAVE	FXLQ32MAVE	FXLQ40MAVE	FXLQ50MAVE	FXLQ63MAVE	
Nominal Capacity	Cooling		kW	2.20	2.80	3.60	4.50	5.60	7.10	
	Heating		kW	2.50	3.20	4.00	5.00	6.30	8.00	
Power input (Nominal)	Cooling		kW	0.049	0.049	0.090	0.090	0.110	0.110	
	Heating		kW	0.049	0.049	0.090	0.090	0.110	0.110	
Casing	Colour			Ivory white (5Y7, 5/1)						
Dimensions	Unit	Height	mm	600	600	600	600	600	600	
		Width	mm	1,000	1,000	1,140	1,140	1,420	1,420	
		Depth	mm	222	222	222	222	222	222	
Weight	Unit		kg	25	25	30	30	36	36	
Heat Exchanger	Dimensions	Nr of Rows		3	3	3	3	3	3	
		Fin Pitch	mm	1.50	1.50	1.50	1.50	1.50	1.50	
		Face Area	m ²	0.159	0.159	0.200	0.200	0.282	0.282	
		Nr of Stages		14	14	14	14	14	14	
Fan	Type			Sirocco fan						
	Quantity			1	1	1	1	1	1	
Air Flow Rate	Cooling	High	m ³ /min	7.00	7.00	8.00	11.00	14.00	16.00	
		Low	m ³ /min	6.00	6.00	6.00	8.50	11.00	12.00	
Fan	Motor	Quantity		1	1	1	1	1	1	
		Model		D14B20	D14B20	2D14B13	2D14B13	2D14B20	2D14B20	
		Output (high)	W	15	15	25	25	35	35	
		Drive			Direct drive					
Refrigerant	Name			R-410A						
Cooling	Sound Pressure	High	dBA	35.0	35.0	35.0	38.0	39.0	40.0	
		Low	dBA	32.0	32.0	32.0	33.0	34.0	35.0	
Piping connections	Liquid (OD)	Type		Flare connection						
		Diameter	mm	6.4	6.4	6.4	6.4	6.4	9.5	
	Gas	Type		Flare connection						
		Diameter	mm	12.7	12.7	12.7	12.7	12.7	15.9	
	Drain	Diameter	mm	O. D. 21						
Heat Insulation			Glass Fiber/Urethane Foam							
Air Filter				Resin net with mold resistance						
Refrigerant control				Electronic expansion valve						
Temperature control				Microprocessor thermostat for cooling and heating						
Safety devices				PC board fuse						
				Fan motor thermal protector						
				Installation and operation manual						
				Insulation for fitting						
Standard Accessories	Standard Accessories				Drain hose					
					Clamps					
					Screws					
					Level adjustment screw					
					Washer					
Notes				Nominal cooling capacities are based on : indoor temperature : 27°CDB, 19°CWB, outdoor temperature : 35°CDB, equivalent refrigerant piping : 7.5m (horizontal)						
				Nominal heating capacities are based on : indoor temperature : 20°CDB, outdoor temperature : 7°CDB, 6°CWB, equivalent refrigerant piping : 7.5m (horizontal)						
				Capacities are net, including a deduction for cooling (an addition for heating) for indoor fan motor heat.						
				Sound pressure levels are measured at 220V						

Floor Standing Unit

1-2 ELECTRICAL SPECIFICATIONS			FXLQ20MAVE	FXLQ25MAVE	FXLQ32MAVE	FXLQ40MAVE	FXLQ50MAVE	FXLQ63MAVE
Power Supply	Name		VE					
	Phase		1	1	1	1	1	1
	Frequency	Hz	50	50	50	50	50	50
	Voltage	V	220-240					
Current	Minimum circuit amps (MCA)	A	0.30	0.30	0.60	0.60	0.60	0.60
	Maximum fuse amps (MFA)	A	15.00	15.00	15.00	15.00	15.00	15.00
	Full load amps (FLA)	A	0.20	0.20	0.50	0.50	0.50	0.50
Voltage range	Minimum	V	-10%					
	Maximum	V	+10%					
Notes			Voltage range : units are suitable for use on electrical systems where voltage supplied to unit terminals is not below or above listed range limits.					
			Maximum allowable voltage range variation between phases is 2%.					
			MCA/MFA : MCA = 1.25 × FLA					
			MFA ≤ 4 × FLA					
			next lower standard fuse rating minimum 15A					
			select wire size based on the MCA					
			instead of a fuse, use a circuit breaker					
			For more details concerning conditional connections, see http://extranet.daikineurope.com , select "E-Data Books". Finally, click on the document title of your choice.					

Concealed Floor Standing Unit

1-1 TECHNICAL SPECIFICATIONS			FXNQ20MAVE	FXNQ25MAVE	FXNQ32MAVE	FXNQ40MAVE	FXNQ50MAVE	FXNQ63MAVE	
Nominal Capacity	Cooling	kW	2.20	2.80	3.60	4.50	5.60	7.10	
	Heating	kW	2.50	3.20	4.00	5.00	6.30	8.00	
Power input (Nominal)	Cooling	kW	0.049	0.049	0.090	0.090	0.110	0.110	
	Heating	kW	0.049	0.049	0.090	0.090	0.110	0.110	
Casing	Material		Galvanised steel						
Dimensions	Unit	Height	mm	610	610	610	610	610	610
		Width	mm	930	930	1,070	1,070	1,350	1,350
		Depth	mm	220	220	220	220	220	220
Weight	Unit		kg	19	19	23	23	27	27
Heat Exchanger	Dimensions	Nr of Rows		3	3	3	3	3	3
		Fin Pitch	mm	1.50	1.50	1.50	1.50	1.50	1.50
		Face Area	m ²	0.159	0.159	0.200	0.200	0.282	0.282
		Nr of Stages		14	14	14	14	14	14
Fan	Type		Sirocco fan						
	Quantity		1	1	1	1	1	1	
Air Flow Rate	Cooling	High	m ³ /min	7.00	7.00	8.00	11.00	14.00	16.00
		Low	m ³ /min	6.00	6.00	6.00	8.50	11.00	12.00
Fan	Motor	Quantity		1	1	1	1	1	1
		Model		D14B20	D14B20	2D14B13	2D14B13	2D14B20	2D14B20
		Output (high)	W	15	15	25	25	35	35
		Drive		Direct drive					
Refrigerant	Name		R-410A						
Cooling	Sound Pressure	High	dBA	35.0	35.0	35.0	38.0	39.0	40.0
		Low	dBA	32.0	32.0	32.0	33.0	34.0	35.0
Piping connections	Liquid (OD)	Type		Flare connection					
		Diameter	mm	6.4	6.4	6.4	6.4	6.4	9.5
	Gas	Type		Flare connection					
		Diameter	mm	12.7	12.7	12.7	12.7	12.7	15.9
	Drain	Diameter	mm	O.D. 21					
Heat Insulation		Glass Fiber/Urethane Foam							
Air Filter			Resin net with mold resistance						
Refrigerant control			Electronic expansion valve						
Temperature control			Microprocessor thermostat for cooling and heating						
Safety devices			PC board fuse						
			Fan motor thermal protector						
			Installation and operation manual						
Standard Accessories	Standard Accessories			Insulation for fitting					
				Drain hose					
				Clamps					
				Screws					
				Washer					
				Level adjustment screw					
Notes			Nominal cooling capacities are based on : indoor temperature : 27°CDB, 19°CWB, outdoor temperature : 35°CDB, equivalent refrigerant piping : 7.5m (horizontal)						
			Nominal heating capacities are based on : indoor temperature : 20°CDB, outdoor temperature : 7°CDB, 6°CWB, equivalent refrigerant piping : 7.5m (horizontal)						
			Capacities are net, including a deduction for cooling (an addition for heating) for indoor fan motor heat.						
			Sound pressure levels are measured at 220V						

Concealed Floor Standing Unit

1-2 ELECTRICAL SPECIFICATIONS			FXNQ20MAVE	FXNQ25MAVE	FXNQ32MAVE	FXNQ40MAVE	FXNQ50MAVE	FXNQ63MAVE
Power Supply	Name		VE					
	Phase		1	1	1	1	1	1
	Frequency	Hz	50	50	50	50	50	50
	Voltage	V	220-240					
Current	Minimum circuit amps (MCA)	A	0.30	0.30	0.60	0.60	0.60	0.60
	Maximum fuse amps (MFA)	A	15.00	15.00	15.00	15.00	15.00	15.00
	Full load amps (FLA)	A	0.20	0.20	0.50	0.50	0.50	0.50
Voltage range	Minimum	V	-10%					
	Maximum	V	+10%					
Notes			Voltage range : units are suitable for use on electrical systems where voltage supplied to unit terminals is not below or above listed range limits.					
			Maximum allowable voltage range variation between phases is 2%					
			MCA/MFA : MCA = 1.25 × FLA					
			MFA ≤ 4 × FLA					
			next lower standard fuse rating minimum 15A					
			select wire size based on the MCA					
			instead of a fuse, use a circuit breaker					
			For more details concerning conditional connections, see http://extranet.daikineurope.com , select "E-Data Books". Finally, click on the document title of your choice.					

4-way Blow Ceiling Suspended Unit

Model	Indoor Unit		FXUQ71MAV1	FXUQ100MAV1	FXUQ125MAV1
	Connection	Unit	BEVQ71MAVE	BEVQ100MAVE	BEVQ125MAVE
★1 Cooling Capacity (19.5°CWB)		kcal/h	7,100	10,000	12,500
		Btu/h	28,300	39,600	49,500
		kW	8.3	11.6	14.5
★2 Cooling Capacity (19.0°CWB)		kW	8.0	11.2	14.0
★3 Heating Capacity		kcal/h	7,700	10,800	12,000
		Btu/h	30,700	42,700	47,800
		kW	9.0	12.5	14.0
Casing Color			White (10Y9/0.5)	White (10Y9/0.5)	White (10Y9/0.5)
Dimensions: (H×W×D)		mm	165×895×895	230×895×895	230×895×895
Coil (Cross Fin Coil)	Rows×Stages×Fin Pitch	mm	3×6×1.5	3×8×1.5	3×8×1.5
	Face Area	m ²	0.265	0.353	0.353
Fan	Model		QTS48A10M	QTS50B15M	QTS50B15M
	Type		Turbo Fan	Turbo Fan	Turbo Fan
	Motor Output × Number of Units	W	45×1	90×1	90×1
	Air Flow Rate (H/L)	m ³ /min	19/14	29/21	32/23
		cfm	671/494	1,024/741	1,130/812
Drive		Direct Drive	Direct Drive	Direct Drive	
Temperature Control			Microprocessor Thermostat for Cooling and Heating	Microprocessor Thermostat for Cooling and Heating	Microprocessor Thermostat for Cooling and Heating
Sound Absorbing Thermal Insulation Material			Heat Resistant Foamed Polyethylene, Regular Foamed Polyethylene	Heat Resistant Foamed Polyethylene, Regular Foamed Polyethylene	Heat Resistant Foamed Polyethylene, Regular Foamed Polyethylene
Piping Connections	Liquid Pipes	mm	φ9.5 (Flare Connection)	φ9.5 (Flare Connection)	φ9.5 (Flare Connection)
	Gas Pipes	mm	φ15.9 (Flare Connection)	φ15.9 (Flare Connection)	φ15.9 (Flare Connection)
	Drain Pipe	mm	I.Dφ20×O.Dφ26	I.Dφ20×O.Dφ26	I.Dφ20×O.Dφ26
Machine Weight (Mass)		kg	25	31	31
★5 Sound Level (H/L)		dBA	40/35	43/38	44/39
Safety Devices			Thermal Protector for Fan Motor	Thermal Protector for Fan Motor	Thermal Protector for Fan Motor
Standard Accessories			Operation Manual, Installation Manual, Drain Hose, Clamp Metal, Insulation for Fitting, Sealing Pads, Clamps, Screws, Washers, Holding Plate.	Operation Manual, Installation Manual, Drain Hose, Clamp Metal, Insulation for Fitting, Sealing Pads, Clamps, Screws, Washers, Holding Plate.	Operation Manual, Installation Manual, Drain Hose, Clamp Metal, Insulation for Fitting, Sealing Pads, Clamps, Screws, Washers, Holding Plate.
Drawing No.			C:4D045395A		

Notes:

- ★1 Indoor temp. : 27°CDB, 19.5°CWB / outdoor temp.: 35°CDB / Equivalent piping length: 7.5m, level difference: 0m.
- ★2 Indoor temp. : 27°CDB, 19.0°CWB / outdoor temp.: 35°CDB / Equivalent piping length: 7.5m, level difference: 0m.
- ★3 Indoor temp. : 20°CDB / outdoor temp.: 7°CDB, 6°CWB / Equivalent piping length: 7.5m, level difference: 0m. (Heat pump only)
- 4 Capacities are net, including a deduction for cooling (an additional for heating) for indoor fan motor heat.
- ★5 Anechoic chamber conversion value, measured at a point 1.5m downward from the unit center. These values are normally somewhat higher during actual operation as a result of ambient conditions.

Conversion Formulae
kcal/h=kW×860
Btu/h=kW×3412
cfm=m ³ /min×35.3

BEV Units

Model		BEVQ71MAVE	BEVQ100MAVE	BEVQ125MAVE
Power Supply		1 Phase 50Hz 220~240V	1 Phase 50Hz 220~240V	1 Phase 50Hz 220~240V
Casing		Galvanized Steel Plate	Galvanized Steel Plate	Galvanized Steel Plate
Dimensions: (H×W×D)		mm	100×350×225	100×350×225
Sound Absorbing Thermal Insulation Material		Flame and Heat Resistant Foamed Polyethylene	Flame and Heat Resistant Foamed Polyethylene	Flame and Heat Resistant Foamed Polyethylene
Piping Connection	Indoor Unit	Liquid Pipes	9.5mm (Flare Connection)	9.5mm (Flare Connection)
		Gas Pipes	15.9mm (Flare Connection)	15.9mm (Flare Connection)
	Outdoor Unit	Liquid Pipes	9.5mm (Flare Connection)	9.5mm (Flare Connection)
		Suction Gas Pipes	15.9mm (Flare Connection)	15.9mm (Flare Connection)
Machine Weight (Mass)		kg	3.0	3.5
Standard Accessories		Installation manual, Gas piping connections, Insulation for fitting, Sealing material, Clamps	Installation manual, Gas piping connections, Insulation for fitting, Sealing material, Clamps	Installation manual, Gas piping connections, Insulation for fitting, Sealing material, Clamps
Drawing No.		4D045387A	4D045387A	4D045388A

1.3 BS Units

Model		BSVQ100PV1	BSVQ160PV1	BSVQ250PV1	
Power Supply		1 Phase 50Hz 200-240V	1 Phase 50Hz 200-240V	1 Phase 50Hz 200-240V	
Total Capacity Index of Indoor Unit		20 to 100	More than 100 but 160 or less	More than 160 but 250 or less	
No. of Connectable Indoor Units		Max. 5	Max. 8	Max. 8	
Casing		Galvanized steel plate	Galvanized steel plate	Galvanized steel plate	
Dimensions: (H×W×D)		mm 207×388×326	207×388×326	207×388×326	
Sound Absorbing Thermal Insulation Material		Foamed polyurethane, Flame resistant needle felt	Foamed polyurethane, Flame resistant needle felt	Foamed polyurethane, Flame resistant needle felt	
Piping Connection	Indoor Unit	Liquid Pipes	9.5mm C1220T (brazing connection) ★1	9.5mm C1220T (brazing connection)	9.5mm C1220T (brazing connection)
		Gas Pipes	15.9mm C1220T (brazing connection) ★1	15.9mm C1220T (brazing connection) ★2	22.2mm C1220T (brazing connection) ★3
	Outdoor Unit	Liquid Pipes	9.5mm C1220T (brazing connection)	9.5mm C1220T (brazing connection)	9.5mm C1220T (brazing connection)
		Suction Gas Pipes	15.9mm C1220T (brazing connection)	15.9mm C1220T (brazing connection) ★2	22.2mm C1220T (brazing connection) ★3
	HP/LP Gas Pipes	12.7mm C1220T (brazing connection)	12.7mm C1220T (brazing connection) ★2	19.1mm C1220T (brazing connection) ★3	
Weight		kg 14	14	15	
Standard Accessories		Installation manual, Attached pipe Insulation pipe cover, Clamps	Installation manual, Attached pipe Insulation pipe cover, Clamps	Installation manual, Attached pipe Insulation pipe cover, Clamps	
Drawing No.		C: 4D057926	C: 4D057927	C: 4D057928	

- Note:**
- ★1 When connecting with a 20 to 50 class indoor unit, connect to the attached pipe to the field pipe. (Braze the connection between the attached and field pipe.)
 - ★2 When connecting with an indoor unit of 150 or more and 160 or less, connect to the attached pipe to the field pipe. (Braze the connection between the attached and field pipe.)
 - ★3 When connecting with a 200 class, or more than 160 and less than 200 class indoor unit, connect to the attached pipe to the field pipe. (Braze the connection between the attached and field pipe.)

Connection Range for BS Unit

Components	Outdoor unit model name	Total capacity of connectable indoor units	Number of connectable indoor units
Indoor unit total capacity	REYQ8P	100 to 260 (400)	13 (20)
	REYQ10P	125 to 325 (500)	16 (25)
	REYQ12P	150 to 390 (600)	19 (30)
	REYQ14P	175 to 455 (700)	22 (35)
	REYQ16P	200 to 520 (800)	26 (40)
	REYQ18P	225 to 585 (720)	29 (36)
	REYQ20P	250 to 650 (800)	32 (40)
	REYQ22P	275 to 715 (880)	35 (44)
	REYQ24P	300 to 780 (960)	39 (48)
	REYQ26P	325 to 845 (1,040)	42 (52)
	REYQ28P	350 to 910 (1,120)	45 (56)
	REYQ30P	375 to 975 (1,200)	48 (60)
	REYQ32P	400 to 1,040 (1,280)	52 (64)
	REYQ34P	425 to 1,105 (1,105)	55 (55)
	REYQ36P	450 to 1,170 (1,170)	58 (58)
	REYQ38P	475 to 1,235 (1,235)	61 (61)
	REYQ40P	500 to 1,300 (1,300)	64 (64)
	REYQ42P	525 to 1,365 (1,365)	
REYQ44P	550 to 1,430 (1,430)		
REYQ46P	575 to 1,495 (1,495)		
REYQ48P	600 to 1,560 (1,560)		

- Note:**
- ★ Values inside brackets are based on connection of indoor units rated at maximum capacity, 200% from single outdoor units, 160% from double outdoor units, 130% from triple outdoor units.

Part 3

Refrigerant Circuit

- 1. Refrigerant Circuit50
 - 1.1 REYQ8P, 10P, 12P50
 - 1.2 REYQ14P, 16P52
 - 1.3 REMQ8PY1 (Multi 8HP).....54
 - 1.4 REMQ10PY1, 12PY1 (Multi 10, 12HP).....56
 - 1.5 REMQ14PY1, 16PY1 (Multi 14, 16HP).....58
 - 1.6 BS Unit Functional Parts60
 - 1.7 Indoor Units61
- 2. Functional Parts Layout62
 - 2.1 REYQ8P, 10P, 12P62
 - 2.2 REYQ14P, 16P63
 - 2.3 REMQ8P64
 - 2.4 REMQ10P, 12P.....65
 - 2.5 REMQ14P, 16P.....66
- 3. Refrigerant Flow for Each Operation Mode.....67

1. Refrigerant Circuit

1.1 REYQ8P, 10P, 12P

No. in refrigerant system diagram	Symbol	Name	Major Function
1	M1C	Inverter compressor (INV)	Inverter compressor is operated on frequencies between 52Hz and 210Hz by using the inverter, while Standard compressor is operated with commercial power supply only. The number of operating steps is as follows when Inverter compressor is operated in combination with Standard compressor. REYQ8, 10, 12P : 37 steps
2	M2C	Standard compressor 1 (STD1)	
3	M1F	Inverter fan	Since the system is of air heat exchanging type, the fan is operated at 9-step rotation speed by using the inverter.
4	M2F	Inverter fan	Since the system is of air heat exchanging type, the fan is operated at 9-step rotation speed by using the inverter.
5(6)	Y1E (Y3E)	Electronic expansion valve (Main1 (Main2))	While in heating operation, PI control is applied to keep the outlet superheated degree of air heat exchanger constant.
7(8)	Y2E (Y5E)	Electronic expansion valve (Subcool1 (Subcool2))	PI control is applied to keep the outlet superheated degree of subcooling heat exchanger constant.
9	Y4E	Electronic expansion valve (Refrigerant charge EVJ)	This is used to open/close refrigerant charge port.
10(11)	Y5S (Y10S)	Solenoid valve (Main bypass1 (Main bypass2))	This opens in cooling operation.
12	Y4S	Solenoid valve (Hot gas: SVP)	Used to prevent the low pressure from transient falling.
13	Y3S	Solenoid valve (Refrigerant regulator liquid pipe SVL)	This is used to collect refrigerant to the refrigerant regulator.
14	Y1S	Solenoid valve (Refrigerant regulator gas purging pipe SVG)	This is used to collect refrigerant to the refrigerant regulator.
15	Y7S	Solenoid valve (Refrigerant regulator discharge pipe SVO)	This is used to discharge refrigerant from the refrigerant regulator.
16	Y6S	Solenoid valve (Discharge pipe of refrigerant regulator)	Bypass the high pressure gas to the refrigerant regulator.
17(18)	Y2S (Y9S)	4 way valve (Heat exchanger switch 20SA)	This is used to switch outdoor heat exchanger to evaporator or condenser.
19	Y8S	4 way valve (Dual pressure gas pipe switch 20SB)	This is used to switch dual pressure gas pipe to high pressure or low pressure.
20	S1NPH	High pressure sensor	Used to detect high pressure.
21	S2NPL	Low pressure sensor	Used to detect low pressure.
22	S1PH	HP pressure switch (For INV)	This functions when pressure increases to stop operation and avoid high pressure increase in the fault operation.
23	S2PH	HP pressure switch (For STD)	
24	—	Pressure regulating valve (Liquid pipe)	This is used when pressure increases, to prevent any damage on components caused by pressure increase in transport or storage.
25	—	Pressure regulating valve (Refrigerant regulator)	This is used when pressure increases, to prevent any damage on components caused by pressure increase in transport or storage.
26	—	Subcooling heat exchanger	Apply subcooling to liquid refrigerant.
27	—	Refrigerant regulator	Surplus refrigerant is held according to the operation conditions.
28	—	Capillary tube	Used to return the refrigerating oil separated through the oil separator to the INV compressor.
29	—	Capillary tube	Used to return the refrigerating oil separated through the oil separator to the STD1 compressor.
30	—	Capillary tube	This is used to discharge refrigerant from the refrigerant regulator.
31	R1T	Thermistor (Outdoor air: Ta)	Used to detect outdoor temperature, correct discharge pipe temperature, and others.
32(42)	R8T (R10T)	Thermistor (Suction pipe: TsA)	Used to detect suction pipe temperature.
33	R31T	Thermistor (INV discharge pipe: Tdi)	Used to detect discharge pipe temperature. Used for compressor temperature protection control.
34	R32T	Thermistor (STD1 discharge pipe: Tds1)	
35(45)	R4T (R12T)	Thermistor (Heat exchanger deicer: Tb)	Used to detect liquid pipe temperature of air heat exchanger. Used to make judgments on defrosting operation.
36(46)	R2T (R11T)	Thermistor (Heat exchanger gas pipe Tg)	This detects temperature of gas pipe for air heat exchanger. Used to exercise the constant control of superheated degree when an evaporator is used for outdoor unit heat exchanging.
37(47)	R7T (R15T)	Thermistor (Heat exchanger liquid pipe Tf)	This detects temperature of liquid pipe between the air heat exchanger and main electronic expansion valve. Used to make judgments on the recover or discharge refrigerants to the refrigerant regulator.
38(48)	R5T (R13T)	Thermistor (Subcooling heat exchanger gas pipe: Tsh)	Used to detect gas pipe temperature on the evaporation side of subcooling heat exchanger. Used to exercise the constant control of superheated degree at the outlet of supercooled heat exchanger.
39	R6T	Thermistor (Subcooling heat exchanger liquid pipe Tl)	This detects temperature of liquid pipe between the main expansion valve and subcooling heat exchanger.
40(50)	R9T (R14T)	Thermistor (Liquid pipe Tsc)	This detects temperature of liquid pipe between the liquid stop valve and subcooling heat exchanger.

REYQ8P, 10P, 12P
(8HP, 10HP, 12HP Single Type)
(INV Unit + STD Unit)

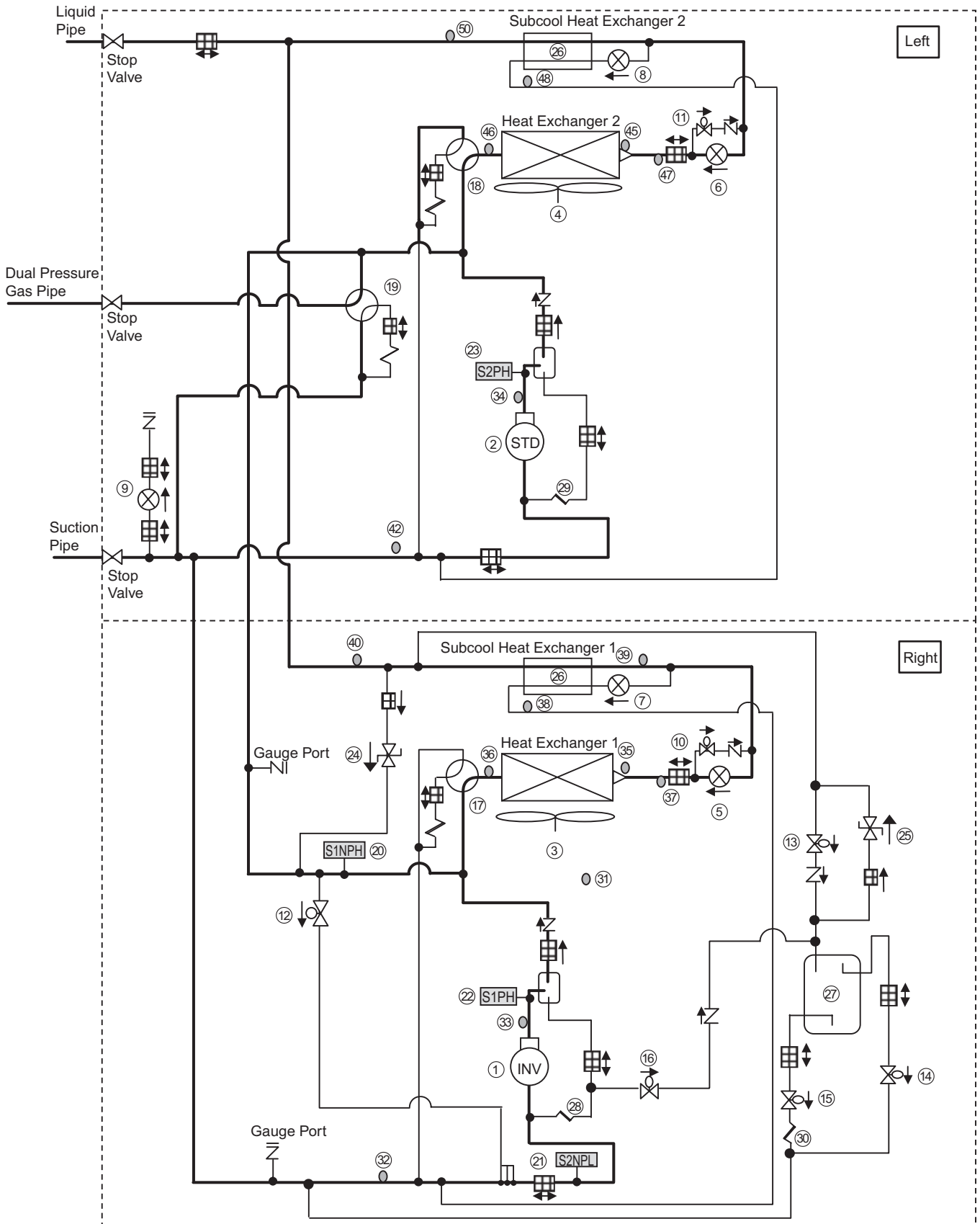

1.2 REYQ14P, 16P

No. in refrigerant system diagram	Symbol	Name	Major Function
1	M1C	Inverter compressor (INV1)	Inverter compressor is operated on frequencies between 52Hz and 266Hz by using the inverter. The number of operating steps is as follows. REYQ14P or 16P : 26 step
2	M2C	Standard compressor 1 (INV2)	
3	M1F	Inverter fan	Since the system is of air heat exchanging type, the fan is operated at 9-step rotation speed by using the inverter.
4	M2F	Inverter fan	Since the system is of air heat exchanging type, the fan is operated at 9-step rotation speed by using the inverter.
5(6)	Y1E (Y3E)	Electronic expansion valve (Main1 (Main2))	While in heating operation, PI control is applied to keep the outlet superheated degree of air heat exchanger constant.
7(8)	Y2E (Y5E)	Electronic expansion valve (Subcool1 (Subcool2))	PI control is applied to keep the outlet superheated degree of subcooling heat exchanger constant.
9	Y4E	Electronic expansion valve (Refrigerant charge EVJ)	This is used to open/close refrigerant charge port.
10(11)	Y5S (Y10S)	Solenoid valve (Main bypass1 (Main bypass2))	This opens in cooling operation.
12	Y4S	Solenoid valve (Hot gas: SVP)	Used to prevent the low pressure from transient falling.
13	Y3S	Solenoid valve (Refrigerant regulator liquid pipe SVL)	This is used to collect refrigerant to the refrigerant regulator.
14	Y1S	Solenoid valve (Refrigerant regulator gas purging pipe SVG)	This is used to collect refrigerant to the refrigerant regulator.
15	Y7S	Solenoid valve (Refrigerant regulator discharge pipe SVO)	This is used to discharge refrigerant from the refrigerant regulator.
16	Y6S	Solenoid valve (Discharge pipe of refrigerant regulator)	Bypass the high pressure gas to the refrigerant regulator.
17(18)	Y2S (Y9S)	4 way valve (Heat exchanger switch 20SA)	This is used to switch outdoor heat exchanger to evaporator or condenser.
19	Y8S	4 way valve (Dual pressure gas pipe switch 20SB)	This is used to switch dual pressure gas pipe to high pressure or low pressure.
20	S1NPH	High pressure sensor	Used to detect high pressure.
21	S2NPL	Low pressure sensor	Used to detect low pressure.
22(23)	S1PH (S2PH)	HP pressure switch (For INV compressor)	This functions when pressure increases to stop operation and avoid high pressure increase in the fault operation.
24	—	Pressure regulating valve (Liquid pipe)	This is used when pressure increases, to prevent any damage on components caused by pressure increase in transport or storage.
25	—	Pressure regulating valve (Refrigerant regulator)	This is used when pressure increases, to prevent any damage on components caused by pressure increase in transport or storage.
26	—	Subcooling heat exchanger	Apply subcooling to liquid refrigerant.
27	—	Refrigerant regulator	Surplus refrigerant is held according to the operation conditions.
28	—	Capillary tube	Used to return the refrigerating oil separated through the oil separator to the INV compressor.
29	—	Capillary tube	This is used to discharge refrigerant from the refrigerant regulator.
30	R1T	Thermistor (Outdoor air: Ta)	Used to detect outdoor temperature, correct discharge pipe temperature, and others.
31(41)	R8T (R10T)	Thermistor (Suction pipe: TsA)	Used to detect suction pipe temperature.
32	R31T	Thermistor (INV1 discharge pipe: Tdi)	Used to detect discharge pipe temperature. Used for compressor temperature protection control.
33	R32T	Thermistor (INV2 discharge pipe: Tds1)	
35(45)	R4T (R12T)	Thermistor (Heat exchanger deicer: Tb)	Used to detect liquid pipe temperature of air heat exchanger. Used to make judgments on defrosting operation.
36(46)	R2T (R11T)	Thermistor (Heat exchanger gas pipe Tg)	This detects temperature of gas pipe for air heat exchanger. Used to exercise the constant control of superheated degree when an evaporator is used for outdoor unit heat exchanging.
37(47)	R7T (R15T)	Thermistor (Heat exchanger liquid pipe Tf)	This detects temperature of liquid pipe between the air heat exchanger and main electronic expansion valve. Used to make judgments on the recover or discharge refrigerants to the refrigerant regulator.
38(48)	R5T (R13T)	Thermistor (Subcooling heat exchanger gas pipe: Tsh)	This detects temperature of gas pipe on the evaporator side for the subcooling heat exchanger. Used to exercise the constant control of superheated degree at the outlet of supercooled heat exchanger.
39	R6T	Thermistor (Subcooling heat exchanger liquid pipe Tl)	This detects temperature of liquid pipe between the main expansion valve and subcooling heat exchanger.
40(50)	R9T (R14T)	Thermistor (Liquid pipe Tsc)	This detects temperature of liquid pipe between the liquid stop valve and subcooling heat exchanger.

REYQ14P, 16P
(14HP, 16HP Single Type)
(INV Unit × 2)

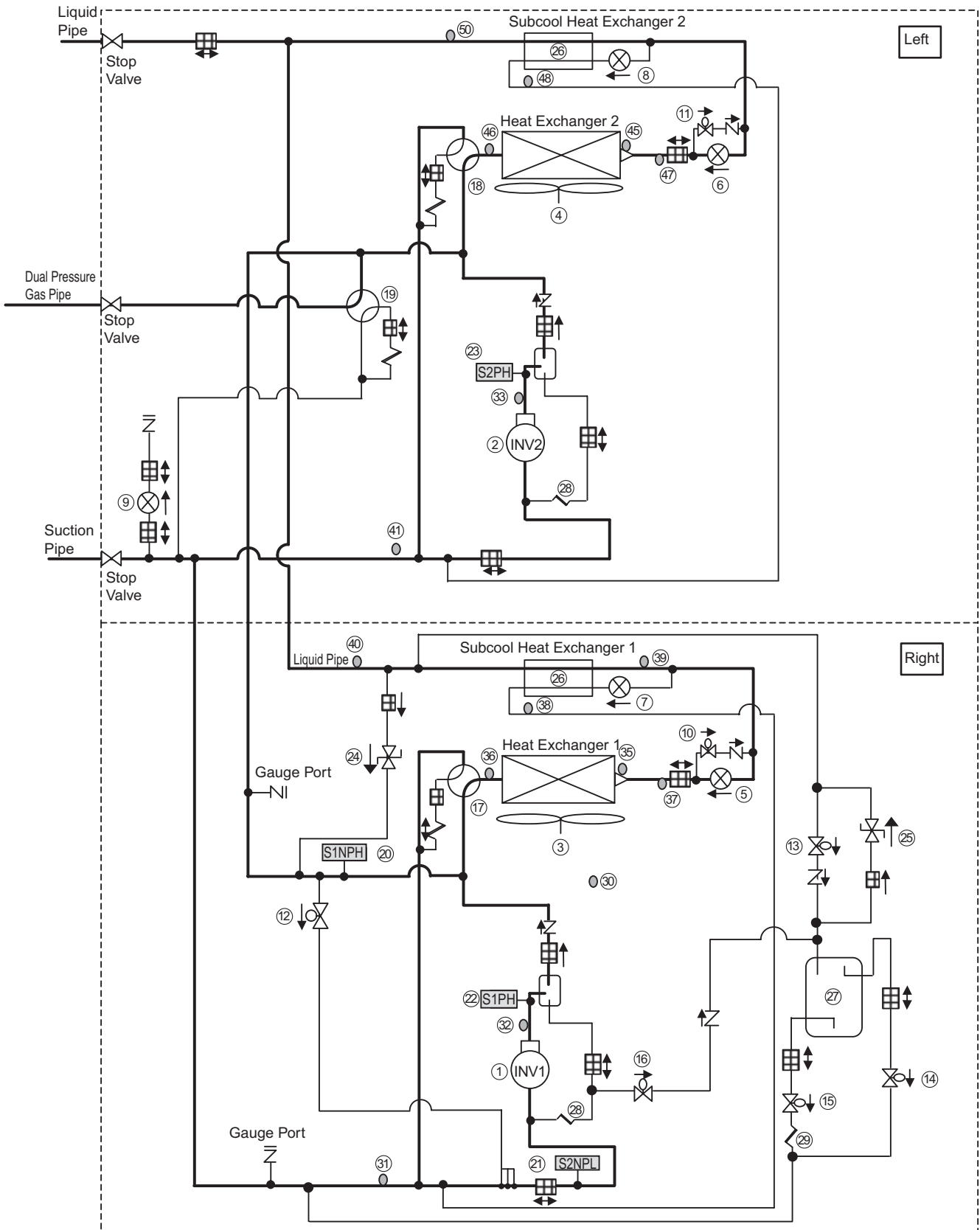

1.3 REMQ8PY1 (Multi 8HP)

No. in refrigerant system diagram	Symbol	Name	Major Function
1	M1C	Inverter compressor (INV)	Inverter compressor is operated on frequencies between 52Hz and 210Hz by using the inverter. Compressor operation steps : Refer to page 112~115.
4	M1F	Inverter fan	Since the system is of air heat exchanging type, the fan is operated at 9-step rotation speed by using the inverter.
6	Y1E	Electronic expansion valve (Main: EVM)	While in heating operation, PI control is applied to keep the outlet superheated degree of air heat exchanger constant.
7	Y3E	Electronic expansion valve (Subcool: EVT)	PI control is applied to keep the outlet superheated degree of subcooling heat exchanger constant.
8	Y2E	Electronic expansion valve (Refrigerant charge EVJ)	This is used to open/close refrigerant charge port.
9	Y6S	Solenoid valve (Main bypass SVE)	This opens in cooling operation.
10	Y5S	Solenoid valve (Hot gas: SVP)	Used to prevent the low pressure from transient falling.
11	Y4S	Solenoid valve (Refrigerant regulator liquid pipe SVL)	This is used to collect refrigerant to the refrigerant regulator.
12	Y1S	Solenoid valve (Refrigerant regulator gas purging pipe SVG)	This is used to collect refrigerant to the refrigerant regulator.
13	Y7S	Solenoid valve (Refrigerant regulator discharge pipe SVO)	This is used to discharge refrigerant from the refrigerant regulator.
14	Y8S	Solenoid valve (Discharge pipe of refrigerant regulator)	Bypass the high pressure gas to the refrigerant regulator.
15	Y3S	4 way valve (Heat exchanger switch 20SA)	This is used to switch outdoor heat exchanger to evaporator or condenser.
16	Y2S	4 way valve (Dual pressure gas pipe switch 20SB)	This is used to switch dual pressure gas pipe to high pressure or low pressure.
17	S1NPH	High pressure sensor	Used to detect high pressure.
18	S2NPL	Low pressure sensor	Used to detect low pressure.
19	S1PH	HP pressure switch (For INV compressor)	This functions when pressure increases to stop operation and avoid high pressure increase in the fault operation.
22	—	Pressure regulating valve (Liquid pipe)	This is used when pressure increases, to prevent any damage on components caused by pressure increase in transport or storage.
23	—	Pressure regulating valve (Refrigerant regulator)	This is used when pressure increases, to prevent any damage on components caused by pressure increase in transport or storage.
24	—	Subcooling heat exchanger	Apply subcooling to liquid refrigerant.
25	—	Refrigerant regulator	Surplus refrigerant is held according to the operation conditions.
26	—	Capillary tube	Used to return the refrigerating oil separated through the oil separator to the INV compressor.
29	—	Capillary tube	This is used to discharge refrigerant from the refrigerant regulator.
30	R1T	Thermistor (Outdoor air: Ta)	Used to detect outdoor temperature.
31	R8T	Thermistor (Suction pipe: TsA)	Used to detect suction pipe temperature.
32	R31T	Thermistor (INV discharge pipe: Tdi)	Used to detect discharge pipe temperature. Used for compressor temperature protection control.
35	R4T	Thermistor (Heat exchanger deicer Tb)	This detects temperature of some of the liquid pipes for air heat exchanger. Used to make judgments on defrosting operation.
36	R2T	Thermistor (Heat exchanger gas pipe Tg)	This detects temperature of gas pipe for air heat exchanger. Used to exercise the constant control of superheated degree when an evaporator is used for outdoor unit heat exchanging.
37	R7T	Thermistor (Heat exchanger liquid pipe Tf)	This detects temperature of liquid pipe between the air heat exchanger and main electronic expansion valve. Used to make judgments on the recover or discharge refrigerants to the refrigerant regulator.
38	R5T	Thermistor (Subcooling heat exchanger gas pipe Tsh)	This detects temperature of gas pipe on the evaporator side for the subcooling heat exchanger. Used to exercise the constant control of superheated degree at the outlet of supercooled heat exchanger.
39	R6T	Thermistor (Subcooling heat exchanger liquid pipe Tl)	This detects temperature of liquid pipe between the main expansion valve and subcooling heat exchanger.
40	R9T	Thermistor (Liquid pipe Tsc)	This detects temperature of liquid pipe between the liquid stop valve and subcooling heat exchanger.

REMQ8PY1

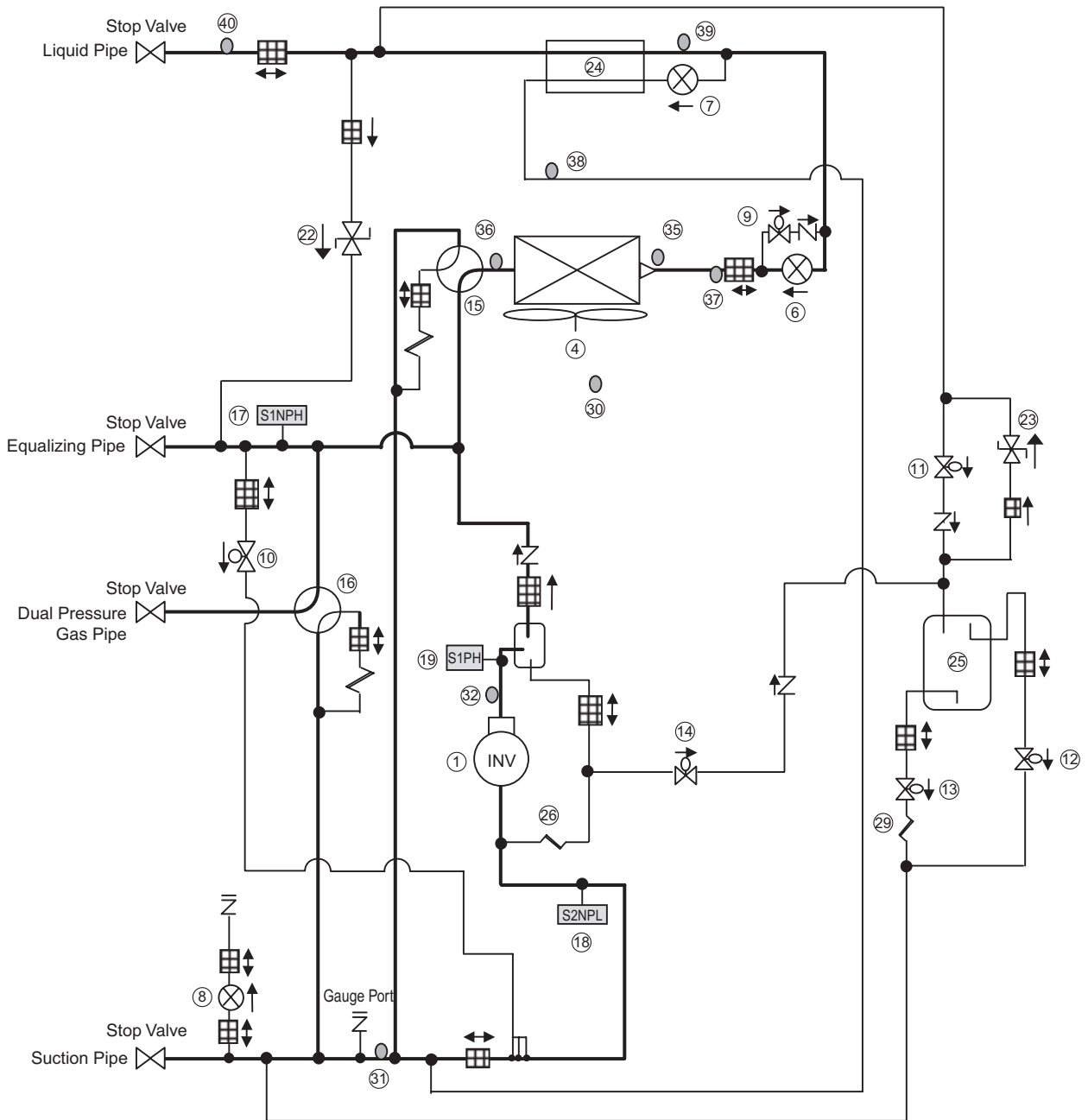

1.4 REMQ10PY1, 12PY1 (Multi 10, 12HP)

No. in refrigerant system diagram	Symbol	Name	Major Function
1	M1C	Inverter compressor (INV)	Inverter compressor is operated on frequencies between 52Hz and 210Hz by using the inverter, while Standard compressor is operated with commercial power supply only. The number of operating steps is as follows when Inverter compressor is operated in combination with Standard compressor. Compressor operation steps : Refer to page 112~115.
2	M2C	Standard compressor 1 (STD1)	
4	M1F	Inverter fan	Since the system is of air heat exchanging type, the fan is operated at 9-step rotation speed by using the inverter.
6	Y1E	Electronic expansion valve (Main: EVM)	While in heating operation, PI control is applied to keep the outlet superheated degree of air heat exchanger constant.
7	Y3E	Electronic expansion valve (Subcool: EVT)	PI control is applied to keep the outlet superheated degree of subcooling heat exchanger constant.
8	Y2E	Electronic expansion valve (Refrigerant charge EVJ)	This is used to open/close refrigerant charge port.
9	Y6S	Solenoid valve (Main bypass SVE)	This opens in cooling operation.
10	Y5S	Solenoid valve (Hot gas: SVP)	Used to prevent the low pressure from transient falling.
11	Y4S	Solenoid valve (Refrigerant regulator liquid pipe SVL)	This is used to collect refrigerant to the refrigerant regulator.
12	Y1S	Solenoid valve (Refrigerant regulator gas purging pipe SVG)	This is used to collect refrigerant to the refrigerant regulator.
13	Y7S	Solenoid valve (Refrigerant regulator discharge pipe SVO)	This is used to discharge refrigerant from the refrigerant regulator.
14	Y8S	Solenoid valve (Discharge pipe of refrigerant regulator)	Bypass the high pressure gas to the refrigerant regulator.
15	Y3S	4 way valve (Heat exchanger switch 20SA)	This is used to switch outdoor heat exchanger to evaporator or condenser.
16	Y2S	4 way valve (Dual pressure gas pipe switch 20SB)	This is used to switch dual pressure gas pipe to high pressure or low pressure.
17	S1NPH	High pressure sensor	Used to detect high pressure.
18	S2NPL	Low pressure sensor	Used to detect low pressure.
19	S1PH	HP pressure switch (For INV compressor)	This functions when pressure increases to stop operation and avoid high pressure increase in the fault operation.
20	S2PH	HP pressure switch (For STD compressor 1)	
22	—	Pressure regulating valve (Liquid pipe)	This is used when pressure increases, to prevent any damage on components caused by pressure increase in transport or storage.
23	—	Pressure regulating valve (Refrigerant regulator)	This is used when pressure increases, to prevent any damage on components caused by pressure increase in transport or storage.
24	—	Subcooling heat exchanger	Apply subcooling to liquid refrigerant.
25	—	Refrigerant regulator	Surplus refrigerant is held according to the operation conditions.
26	—	Capillary tube	Used to return the refrigerating oil separated through the oil separator to the INV compressor.
27	—	Capillary tube	Used to return the refrigerating oil separated through the oil separator to the STD1 compressor.
29	—	Capillary tube	This is used to discharge refrigerant from the refrigerant regulator.
30	R1T	Thermistor (Outdoor air: Ta)	Used to detect outdoor temperature, correct discharge pipe temperature, and others.
31	R8T	Thermistor (Suction pipe: TsA)	Used to detect suction pipe temperature.
32	R31T	Thermistor (INV discharge pipe: Tdi)	Used to detect discharge pipe temperature. Used for compressor temperature protection control.
33	R32T	Thermistor (STD1 discharge pipe: Tds1)	
35	R4T	Thermistor (Heat exchanger deicer: Tb)	Used to detect liquid pipe temperature of air heat exchanger. Used to make judgments on defrosting operation.
36	R2T	Thermistor (Heat exchanger gas pipe Tg)	This detects temperature of gas pipe for air heat exchanger. Used to exercise the constant control of superheated degree when an evaporator is used for outdoor unit heat exchanging.
37	R7T	Thermistor (Heat exchanger liquid pipe Tf)	This detects temperature of liquid pipe between the air heat exchanger and main electronic expansion valve. Used to make judgments on the recover or discharge refrigerants to the refrigerant regulator.
38	R5T	Thermistor (Subcooling heat exchanger gas pipe: Tsh)	Used to detect gas pipe temperature on the evaporation side of subcooling heat exchanger. Used to exercise the constant control of superheated degree at the outlet of supercooled heat exchanger.
39	R6T	Thermistor (Subcooling heat exchanger liquid pipe Tl)	This detects temperature of liquid pipe between the main expansion valve and subcooling heat exchanger.
40	R9T	Thermistor (Liquid pipe Tsc)	This detects temperature of liquid pipe between the liquid stop valve and subcooling heat exchanger.

REMQU10PY1, 12PY1

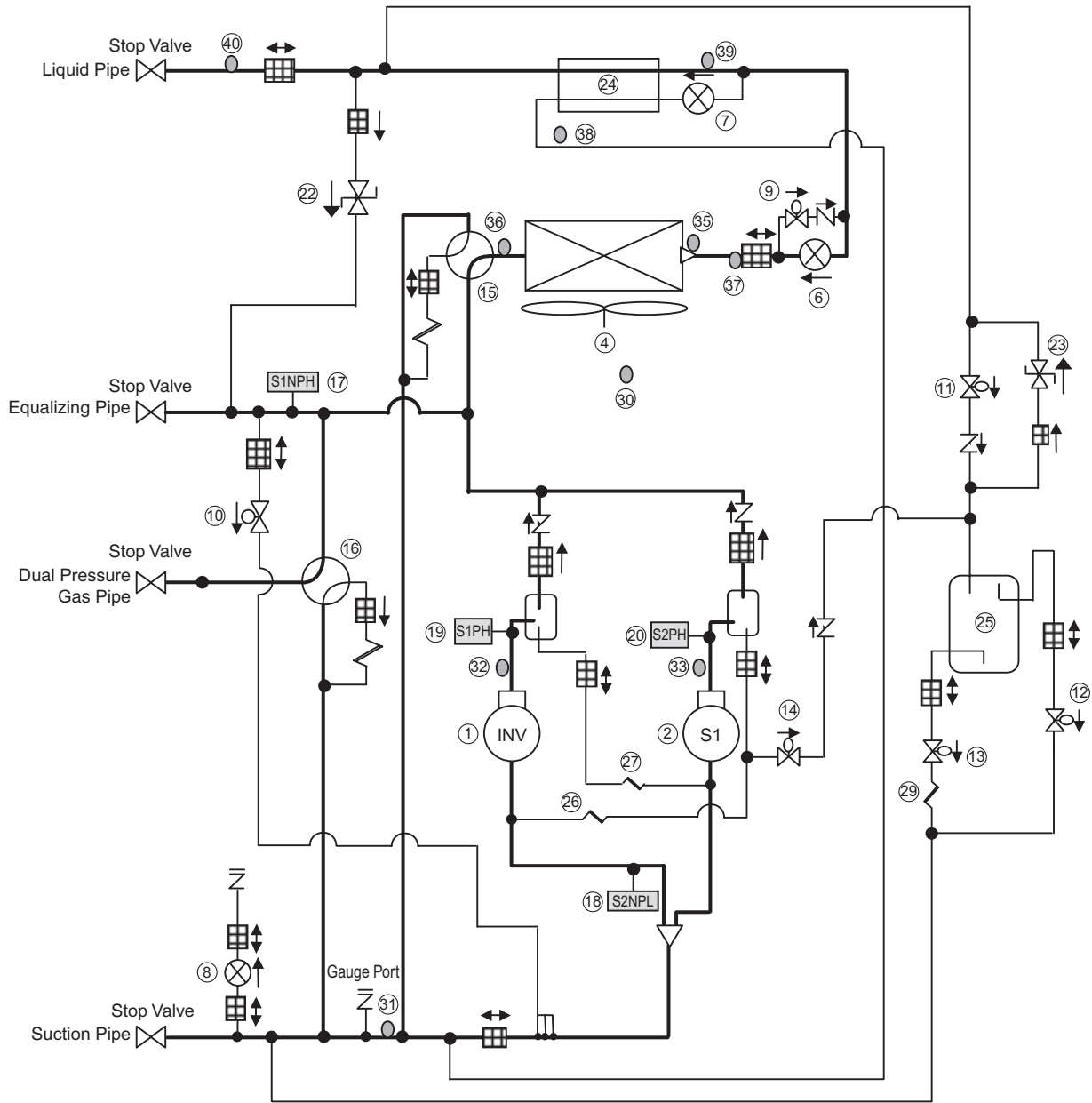

1.5 REMQ14PY1, 16PY1 (Multi 14, 16HP)

No. in refrigerant system diagram	Symbol	Name	Major Function
1	M1C	Inverter compressor (INV)	Inverter compressor is operated on frequencies between 52Hz and 210Hz by using the inverter, while Standard compressor is operated with commercial power supply only. The number of operating steps is as follows when Inverter compressor is operated in combination with Standard compressor. Compressor operation steps : Refer to page 112~115.
2	M2C	Standard compressor 1 (STD1)	
3	M3C	Standard compressor 2 (STD2)	
4	M1F	Inverter fan	Since the system is of air heat exchanging type, the fan is operated at 9-step rotation speed by using the inverter.
5	M2F	Inverter fan	Since the system is of air heat exchanging type, the fan is operated at 9-step rotation speed by using the inverter.
6	Y1E	Electronic expansion valve (Main: EVM)	While in heating operation, PI control is applied to keep the outlet superheated degree of air heat exchanger constant.
7	Y3E	Electronic expansion valve (Subcool: EVT)	PI control is applied to keep the outlet superheated degree of subcooling heat exchanger constant.
8	Y2E	Electronic expansion valve (Refrigerant charge EVJ)	This is used to open/close refrigerant charge port.
9	Y6S	Solenoid valve (Main bypass SVE)	This opens in cooling operation.
10	Y5S	Solenoid valve (Hot gas: SVP)	Used to prevent the low pressure from transient falling.
11	Y4S	Solenoid valve (Refrigerant regulator liquid pipe SVL)	This is used to collect refrigerant to the refrigerant regulator.
12	Y1S	Solenoid valve (Refrigerant regulator gas purging pipe SVG)	This is used to collect refrigerant to the refrigerant regulator.
13	Y7S	Solenoid valve (Refrigerant regulator discharge pipe SVO)	This is used to discharge refrigerant from the refrigerant regulator.
14	Y8S	Solenoid valve (Discharge pipe of refrigerant regulator)	Bypass the high pressure gas to the refrigerant regulator.
15	Y3S	4 way valve (Heat exchanger switch 20SA)	This is used to switch outdoor heat exchanger to evaporator or condenser.
16	Y2S	4 way valve (Dual pressure gas pipe switch 20SB)	This is used to switch dual pressure gas pipe to high pressure or low pressure.
17	S1NPH	High pressure sensor	Used to detect high pressure.
18	S2NPL	Low pressure sensor	Used to detect low pressure.
19	S1PH	HP pressure switch (For INV compressor)	This functions when pressure increases to stop operation and avoid high pressure increase in the fault operation.
20	S2PH	HP pressure switch (For STD compressor 1)	
21	S3PH	HP pressure switch (For STD compressor 2)	
22	—	Pressure regulating valve (Liquid pipe)	This is used when pressure increases, to prevent any damage on components caused by pressure increase in transport or storage.
23	—	Pressure regulating valve (Refrigerant regulator)	This is used when pressure increases, to prevent any damage on components caused by pressure increase in transport or storage.
24	—	Subcooling heat exchanger	Apply subcooling to liquid refrigerant.
25	—	Refrigerant regulator	Surplus refrigerant is held according to the operation conditions.
26	—	Capillary tube	Used to return the refrigerating oil separated through the oil separator to the INV compressor.
27	—	Capillary tube	Used to return the refrigerating oil separated through the oil separator to the STD1 compressor.
28	—	Capillary tube	Used to return the refrigerating oil separated through the oil separator to the STD2 compressor.
29	—	Capillary tube	This is used to discharge refrigerant from the refrigerant regulator.
30	R1T	Thermistor (Outdoor air: Ta)	Used to detect outdoor temperature, correct discharge pipe temperature, and others.
31	R8T	Thermistor (Suction pipe: TsA)	Used to detect suction pipe temperature.
32	R31T	Thermistor (INV discharge pipe: Tdi)	Used to detect discharge pipe temperature. Used for compressor temperature protection control.
33	R32T	Thermistor (STD1 discharge pipe: Tds1)	
34	R33T	Thermistor (STD2 discharge pipe: Tds2)	
35	R4T	Thermistor (Heat exchanger deicer: Tb)	Used to detect liquid pipe temperature of air heat exchanger. Used to make judgments on defrosting operation.
36	R2T	Thermistor (Heat exchanger gas pipe Tg)	This detects temperature of gas pipe for air heat exchanger. Used to exercise the constant control of superheated degree when an evaporator is used for outdoor unit heat exchanging.
37	R7T	Thermistor (Heat exchanger liquid pipe Tf)	This detects temperature of liquid pipe between the air heat exchanger and main electronic expansion valve. Used to make judgments on the recover or discharge refrigerants to the refrigerant regulator.
38	R5T	Thermistor (Subcooling heat exchanger gas pipe: Tsh)	This detects temperature of gas pipe on the evaporator side for the subcooling heat exchanger. Used to exercise the constant control of superheated degree at the outlet of supercooled heat exchanger.
39	R6T	Thermistor (Subcooling heat exchanger liquid pipe Tl)	This detects temperature of liquid pipe between the main expansion valve and subcooling heat exchanger.
40	R9T	Thermistor (Liquid pipe Tsc)	This detects temperature of liquid pipe between the liquid stop valve and subcooling heat exchanger.

REMQR14PY1, 16PY1

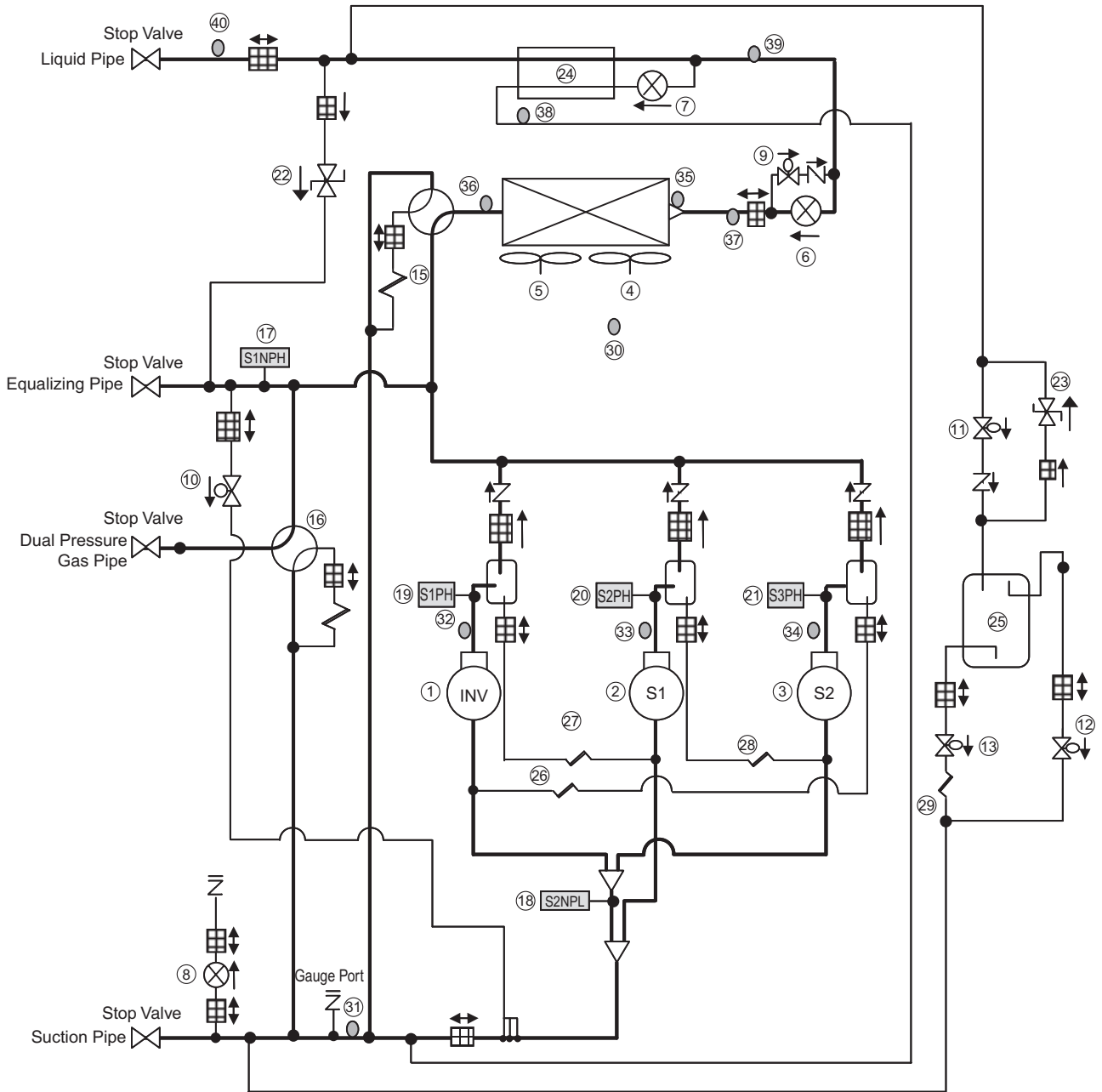

1.6 BS Unit Functional Parts

BSVQ100,160,250PV1

No.	Name	Symbol	Function
1	Electronic expansion valve (EVH)	Y4E	Opens while in heating operation or all indoor units are in cooling operation. (Max : 760pls)
2	Electronic expansion valve (EVL)	Y5E	Opens while in cooling operation. (Max : 760pls)
3	Electronic expansion valve (EVHS)	Y2E	Opens while in heating operation or all indoor units are in cooling operation. (Max : 480pls)
4	Electronic expansion valve (EVLS)	Y3E	Opens while in cooling operation. (Max : 480pls)
5	Electronic expansion valve (EVSC)	Y1E	In simultaneous cooling and heating operation, it is used to subcool liquid refrigerants when an indoor unit downstream of this BS unit is in heating operation.(Max : 480pls)
6	Capillary tube		Used to bypass high pressure gas to low pressure side to protect "Refrigerant accumulation" in high and low pressure gas pipes.

Note : Factory set of all EV opening : 60pls

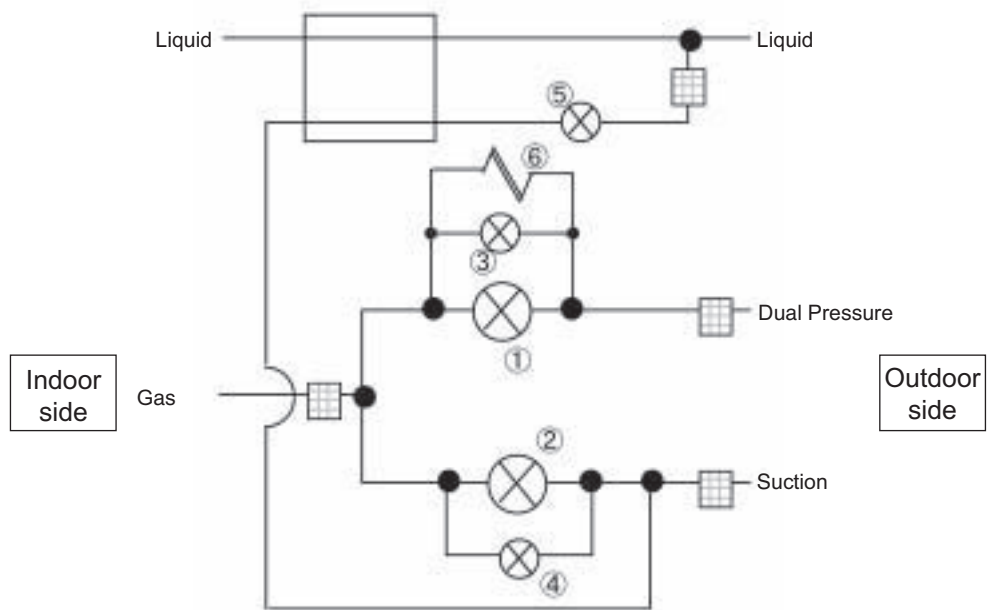

1.7 Indoor Units

FXCQ, FXFQ, FXZQ, FXKQ, FXDQ, FXDYQ, FXSQ, FXMQ, FXHQ, FXAQ, FXLQ, FXNQ

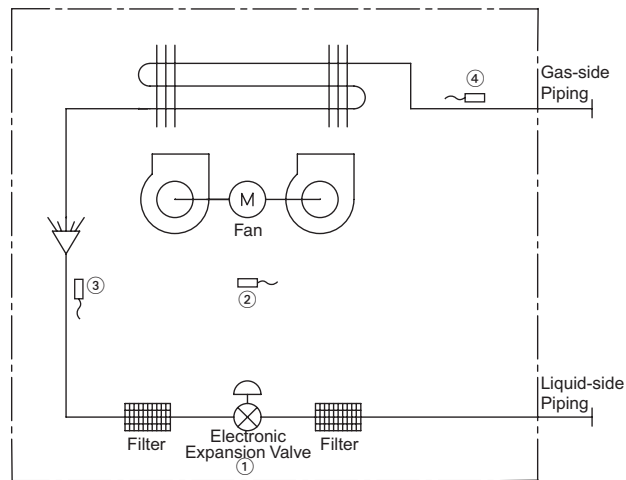

No.	Name	Symbol	Function
①	Electronic expansion valve	Y1E	Used to control superheated degree of gas when cooling and subcooled degree when heating. (Max. 2000 pls)
②	Suction air thermistor	R1T	Used for thermostat control.
③	Liquid pipe thermistor	R2T	Used to control superheated degree of gas when cooling and subcooled degree when heating.
④	Gas pipe thermistor	R3T	Used for gas superheated degree control when cooling.

2. Functional Parts Layout

2.1 REYQ8P, 10P, 12P

Plan

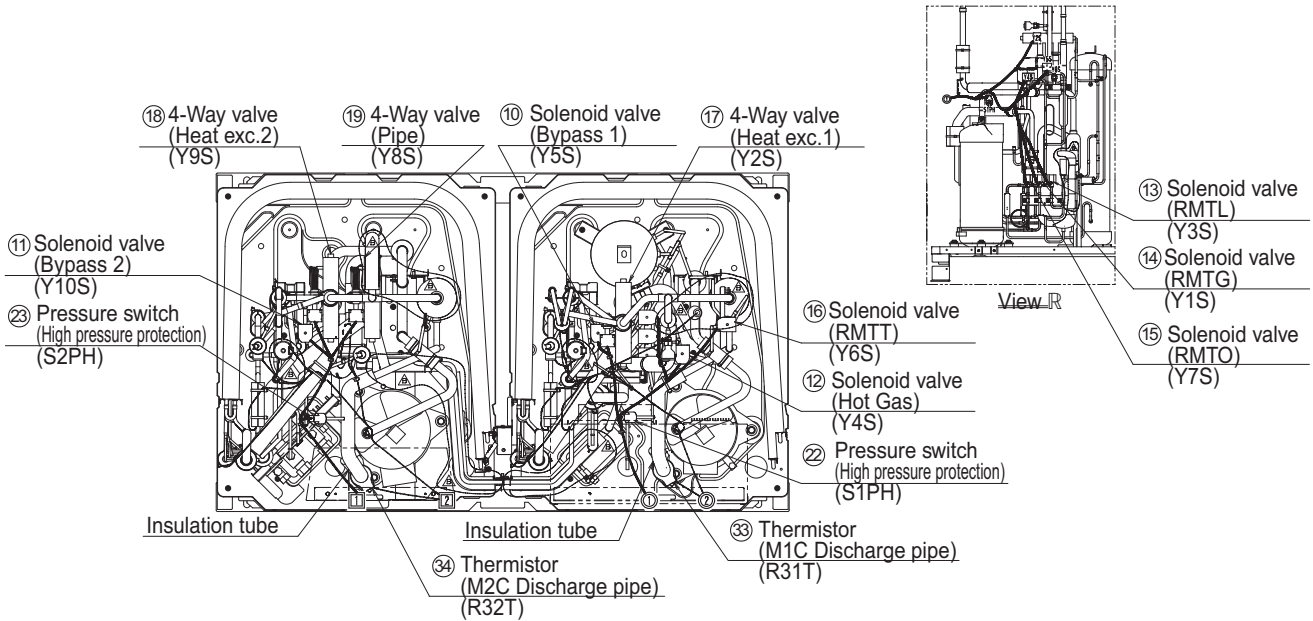

Front View

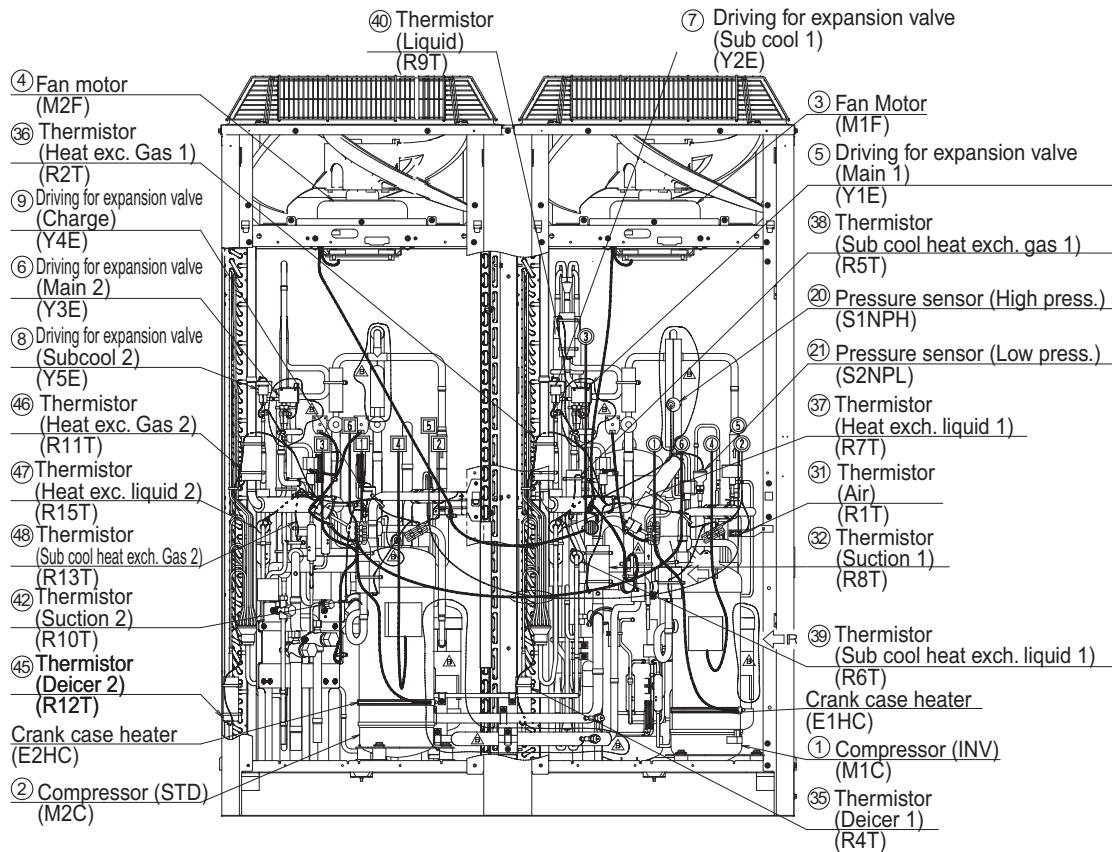

Note: For reference numbers, refer to page 58.

2.2 REYQ14P, 16P

Plan

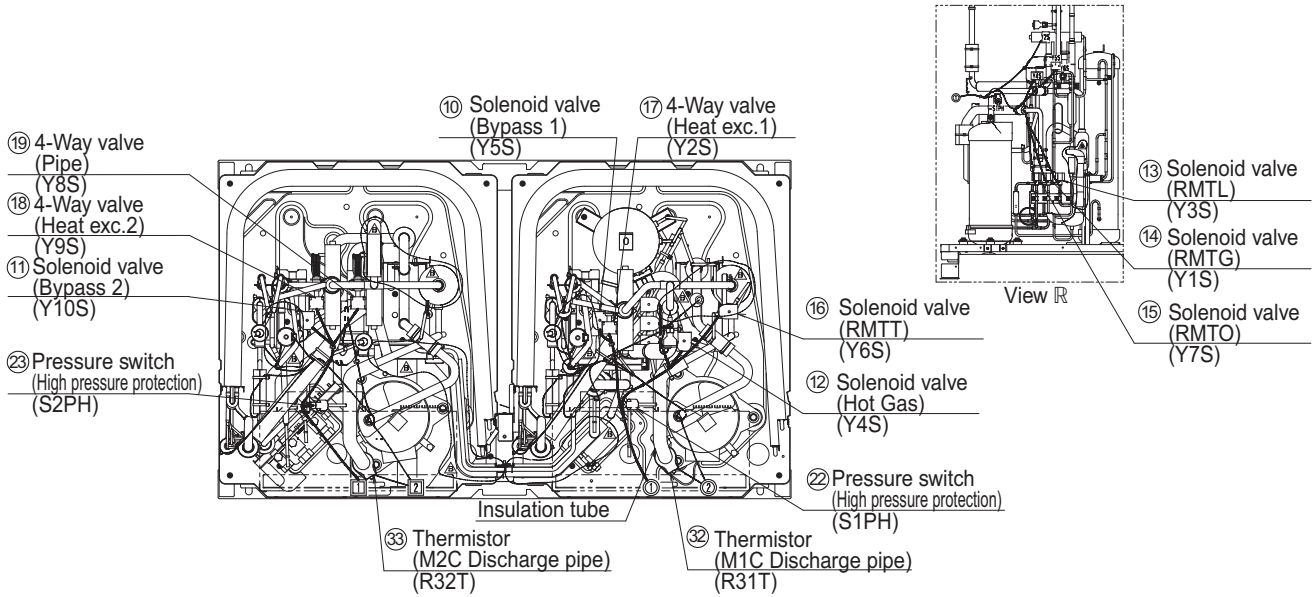

Front View

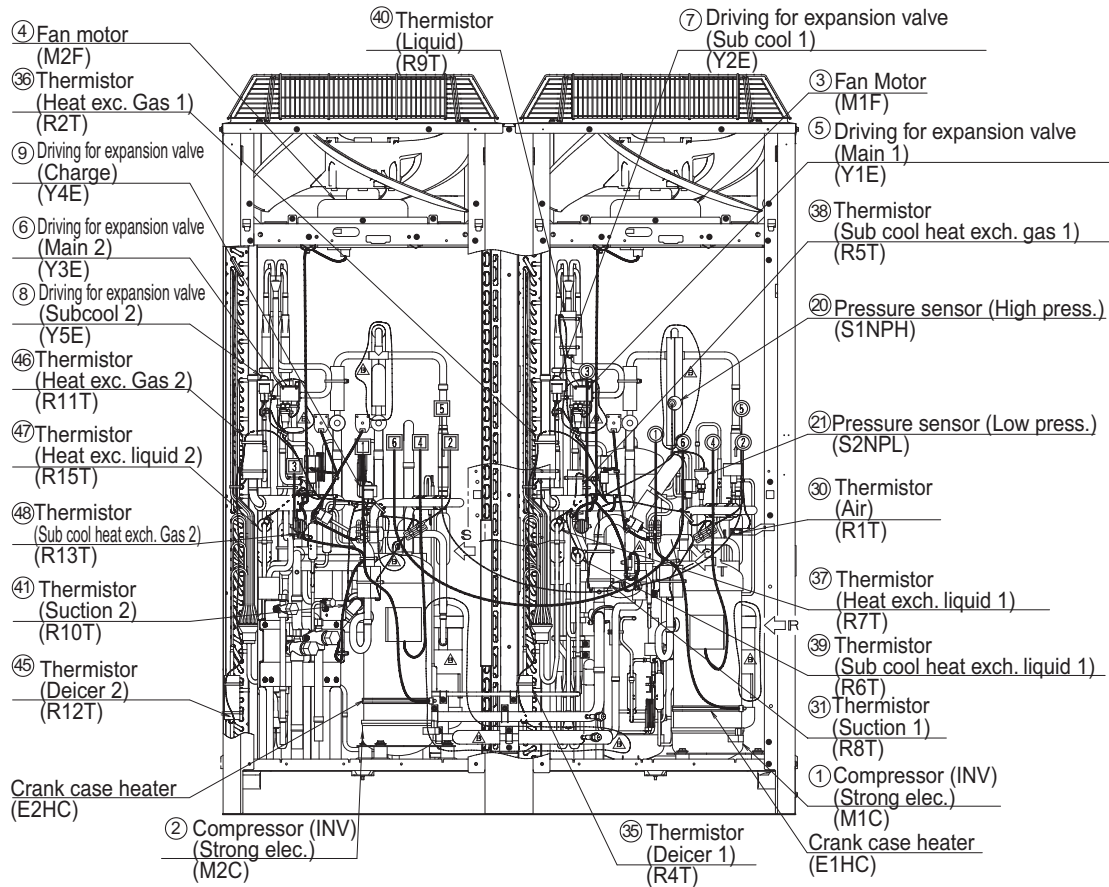

Note: For reference numbers, refer to page 60.

2.3 REMQ8P

Plan

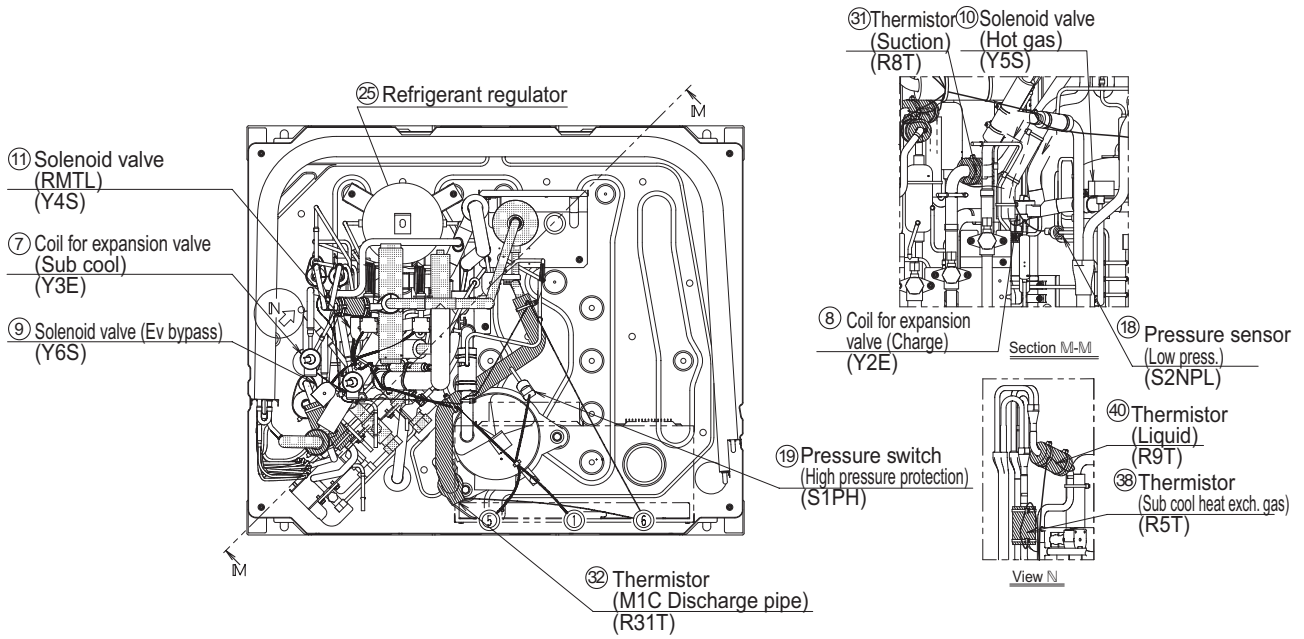

Front View

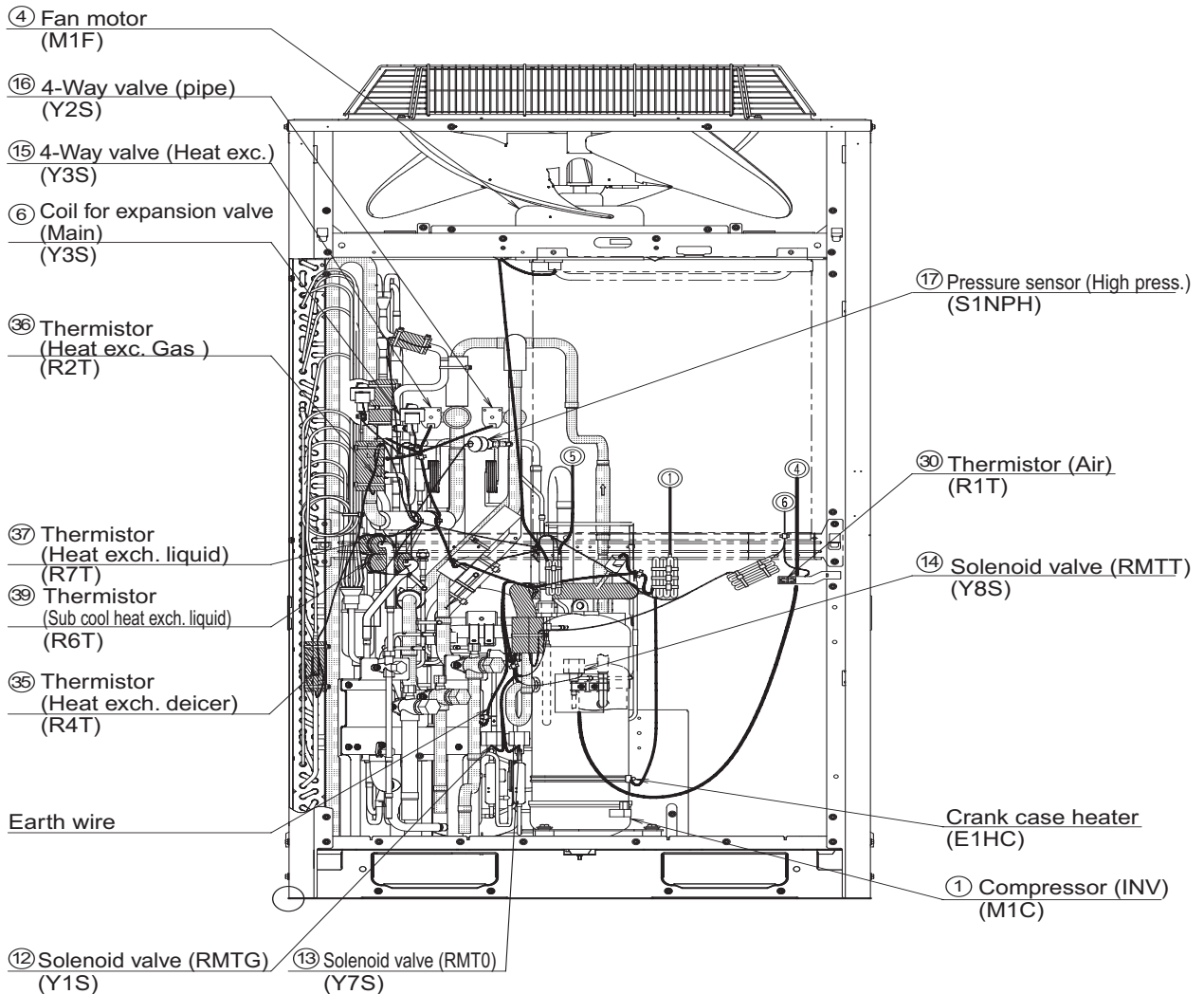

Note: For reference numbers, refer to page 62.

2.4 REMQ10P, 12P

Plan

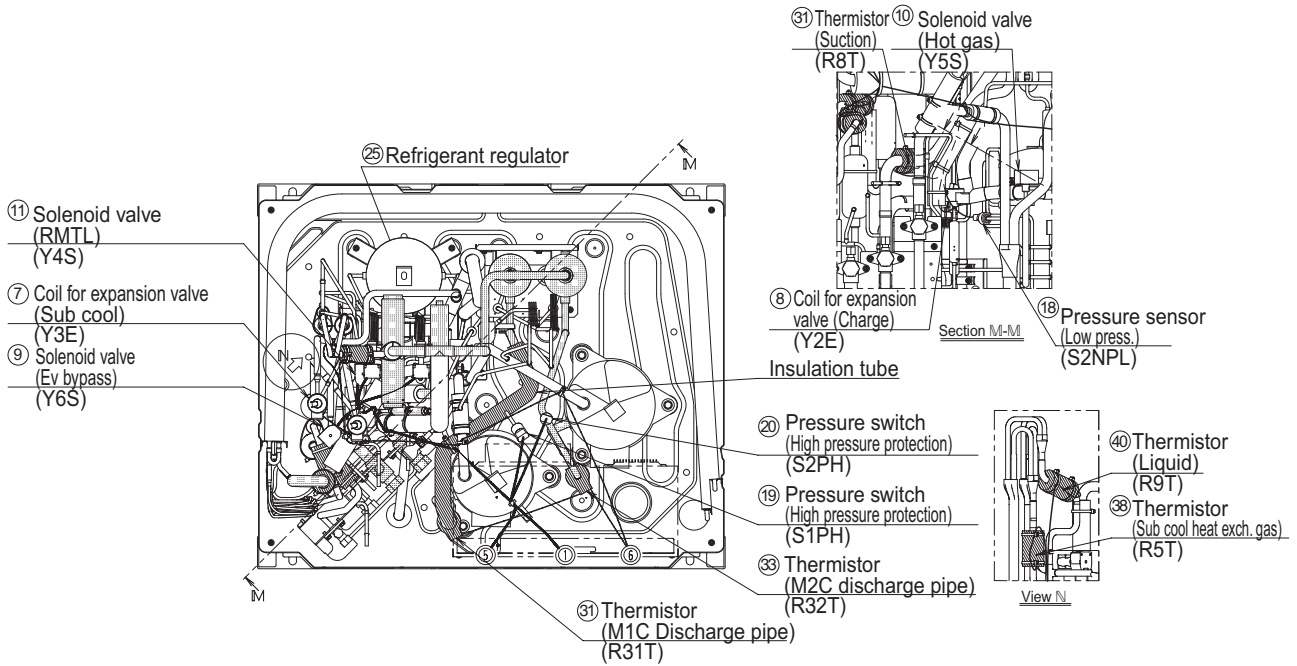

Front View

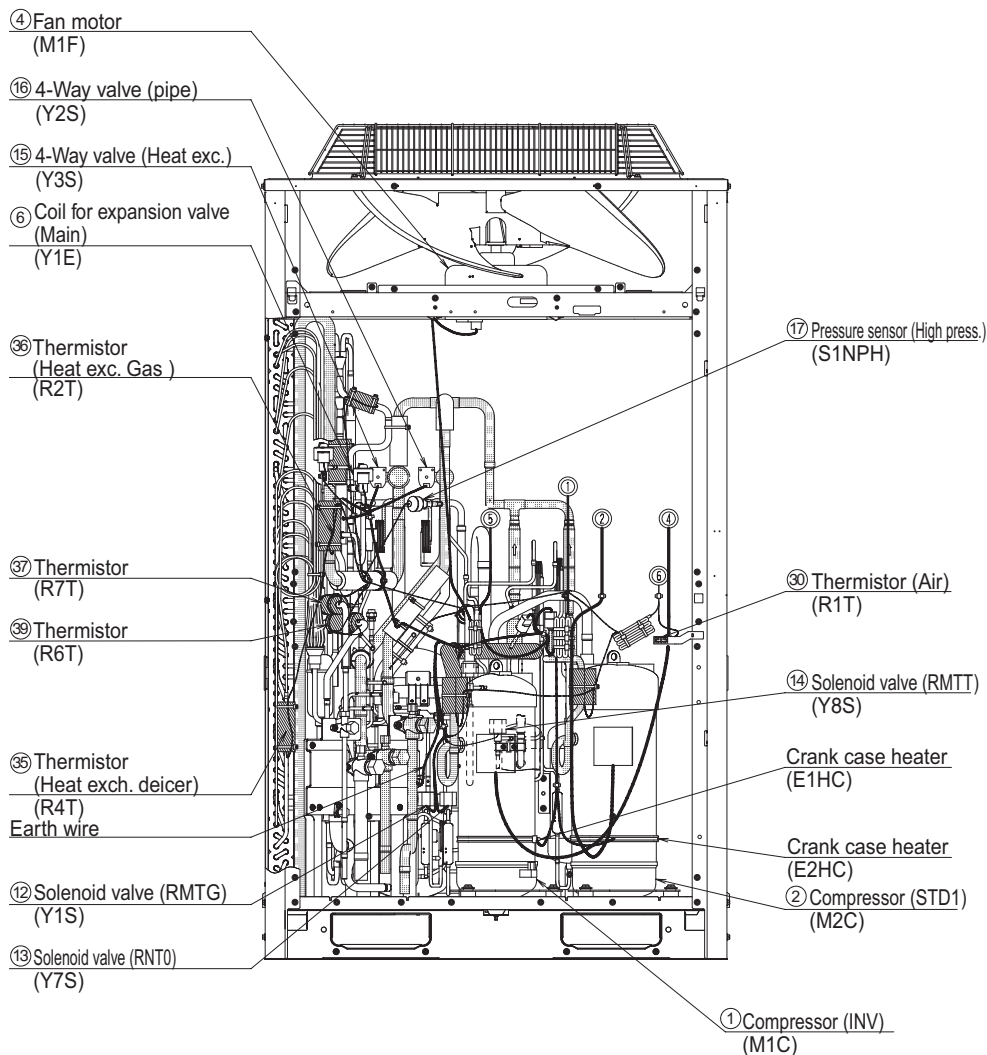

Note: For reference number, refer to page 64.

2.5 REMQ14P, 16P

Plan

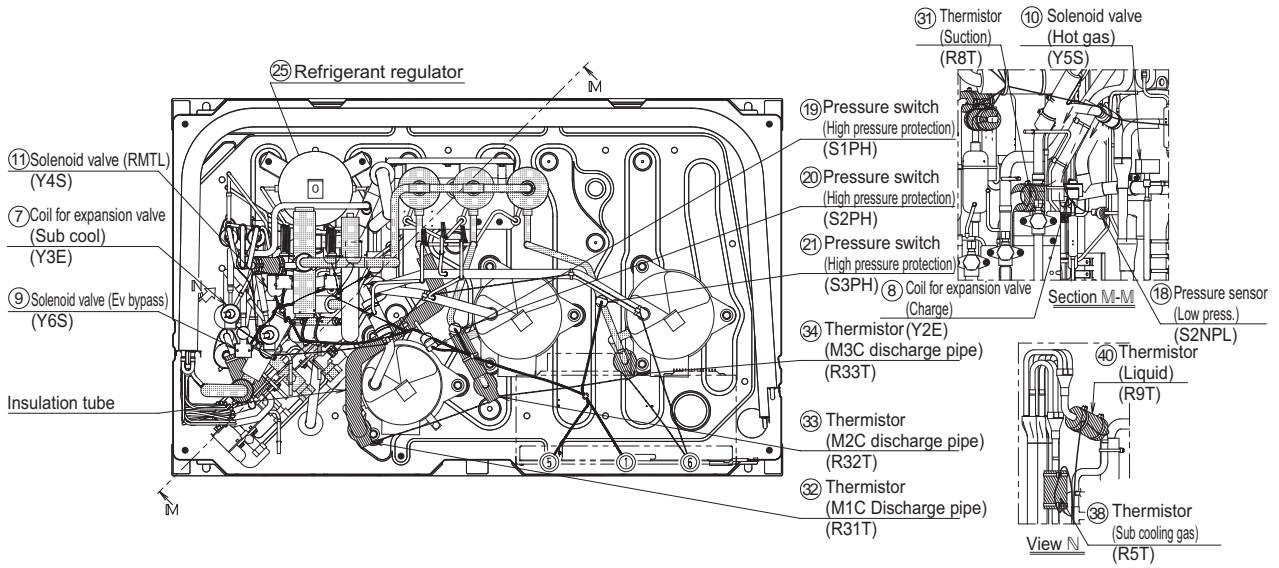

Front View

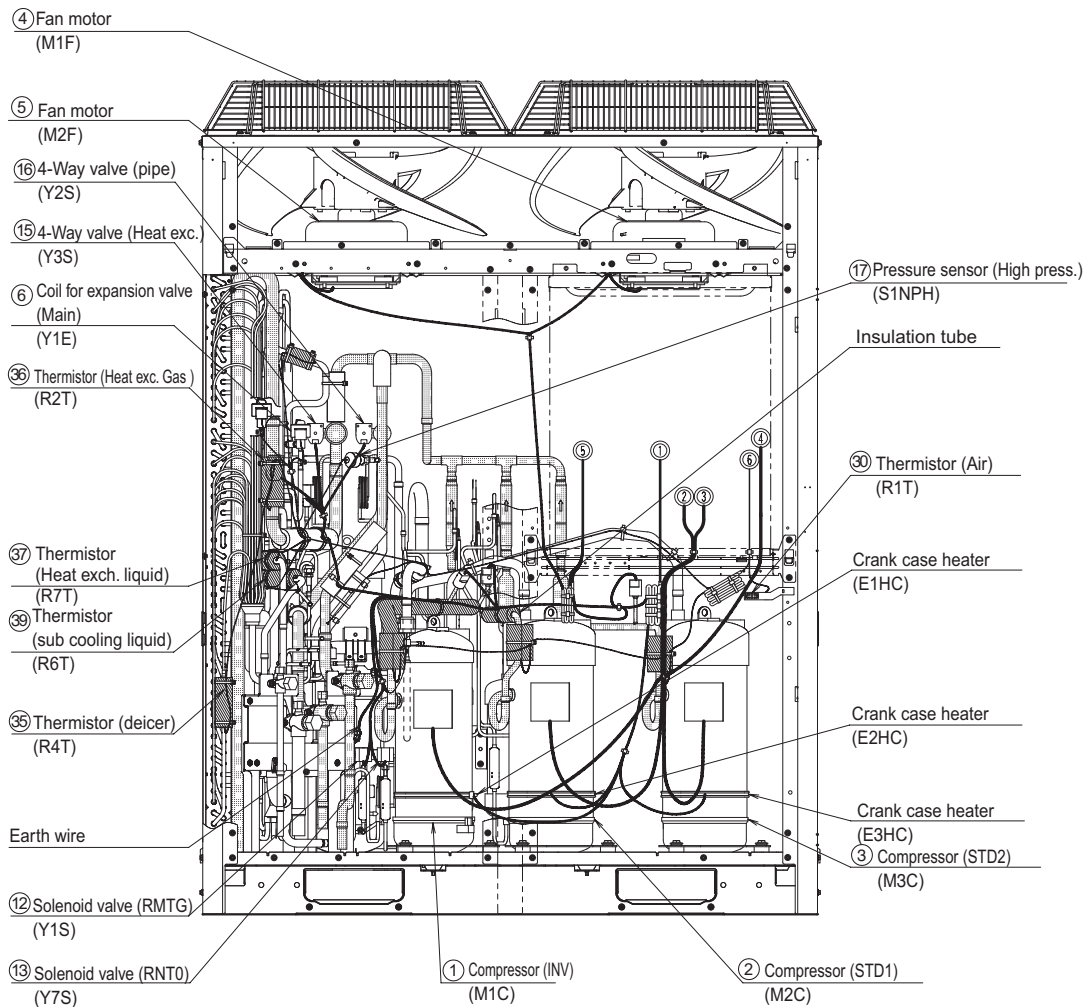

Note: For reference number, refer to page 66.

3. Refrigerant Flow for Each Operation Mode

REYQ8P, 10P, 12P
Cooling Operation

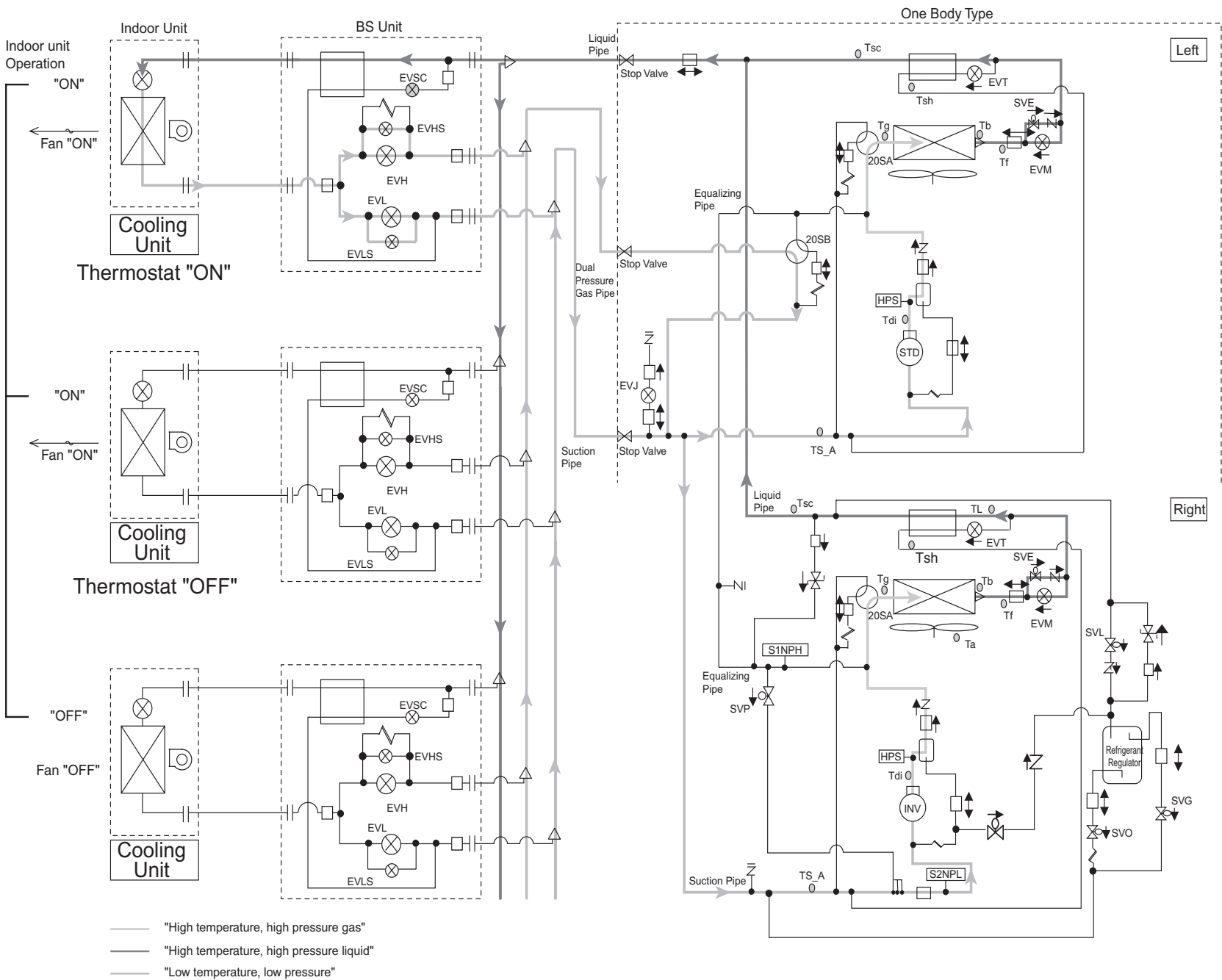

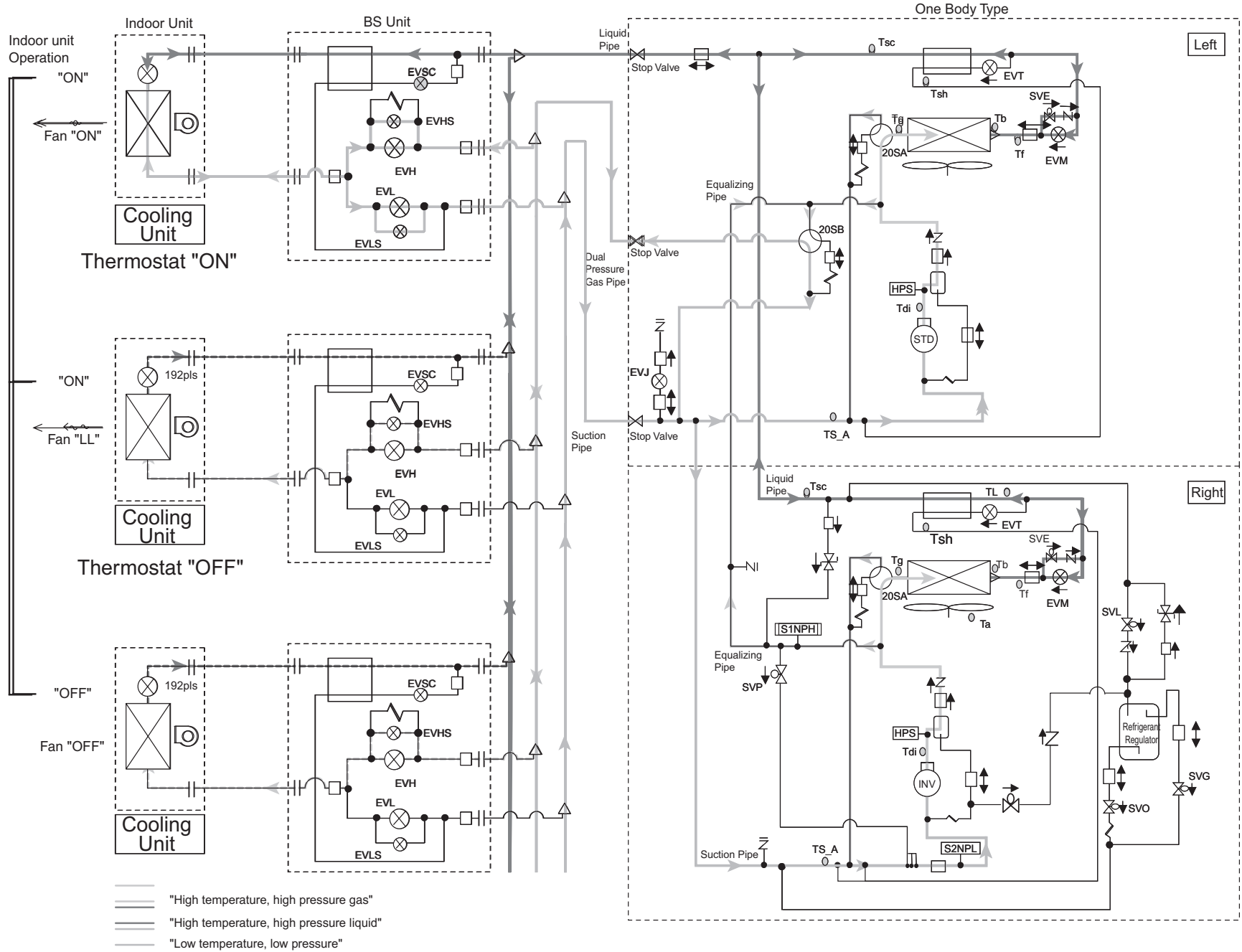

Heating Operation

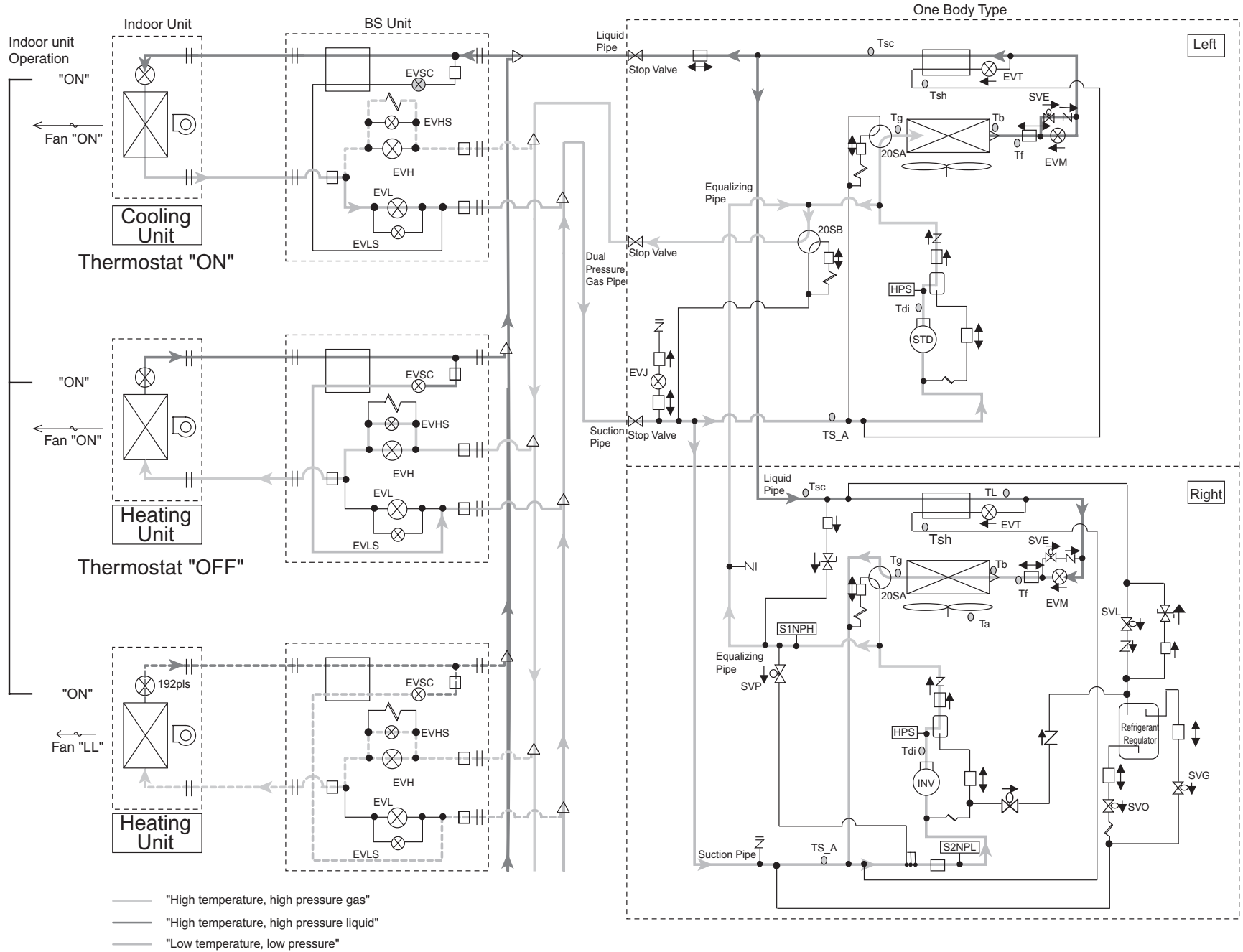

Simultaneous Cooling / Heating Operation

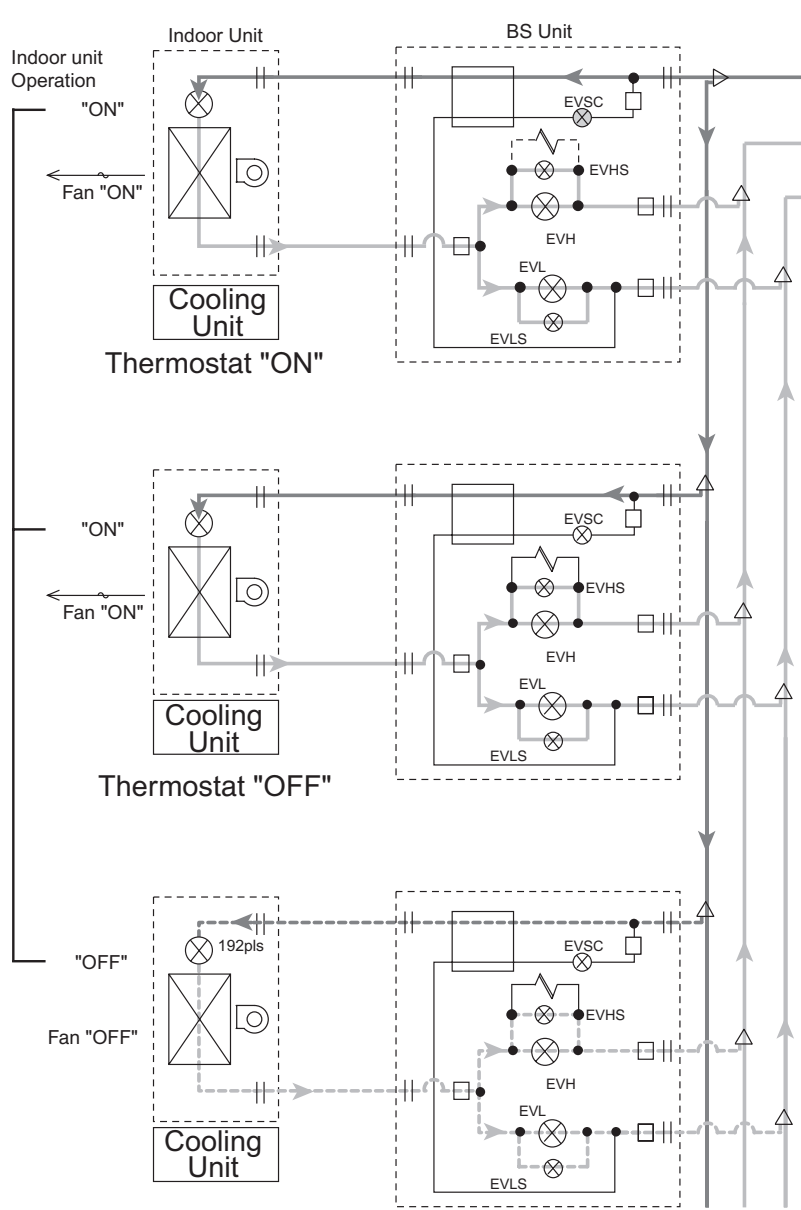

- "High temperature, high pressure gas"
- "High temperature, high pressure liquid"
- "Low temperature, low pressure"

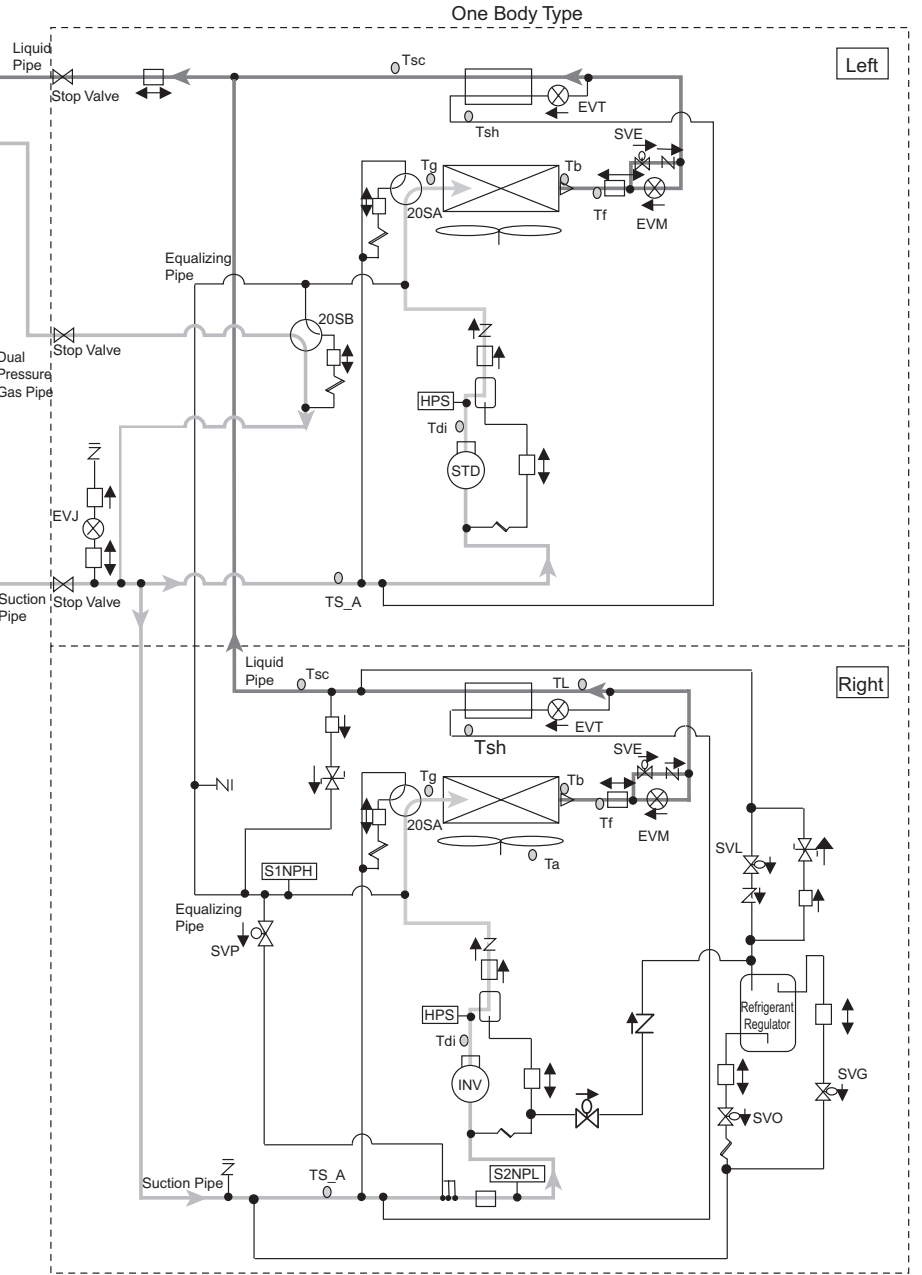

Cooling Oil Return Operation

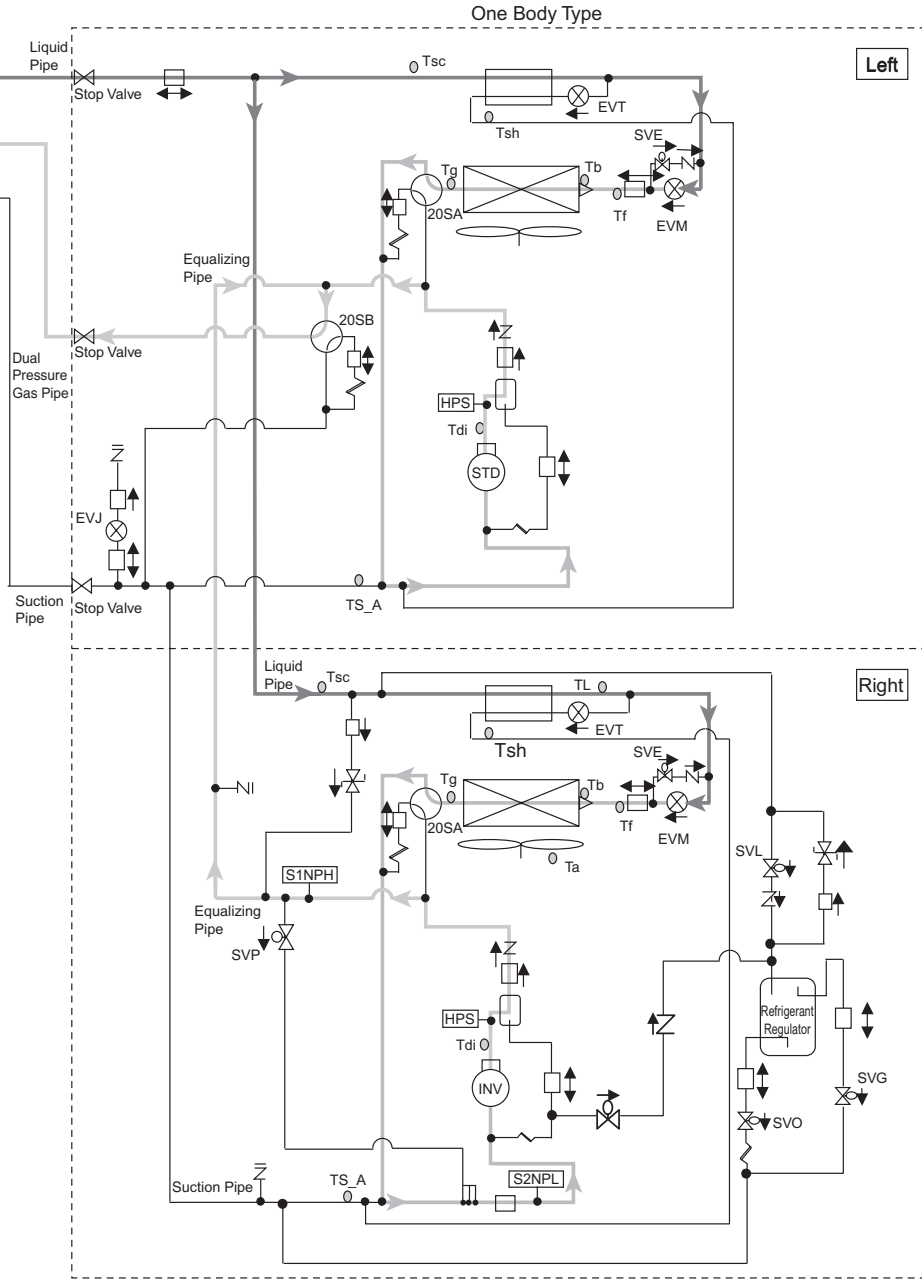
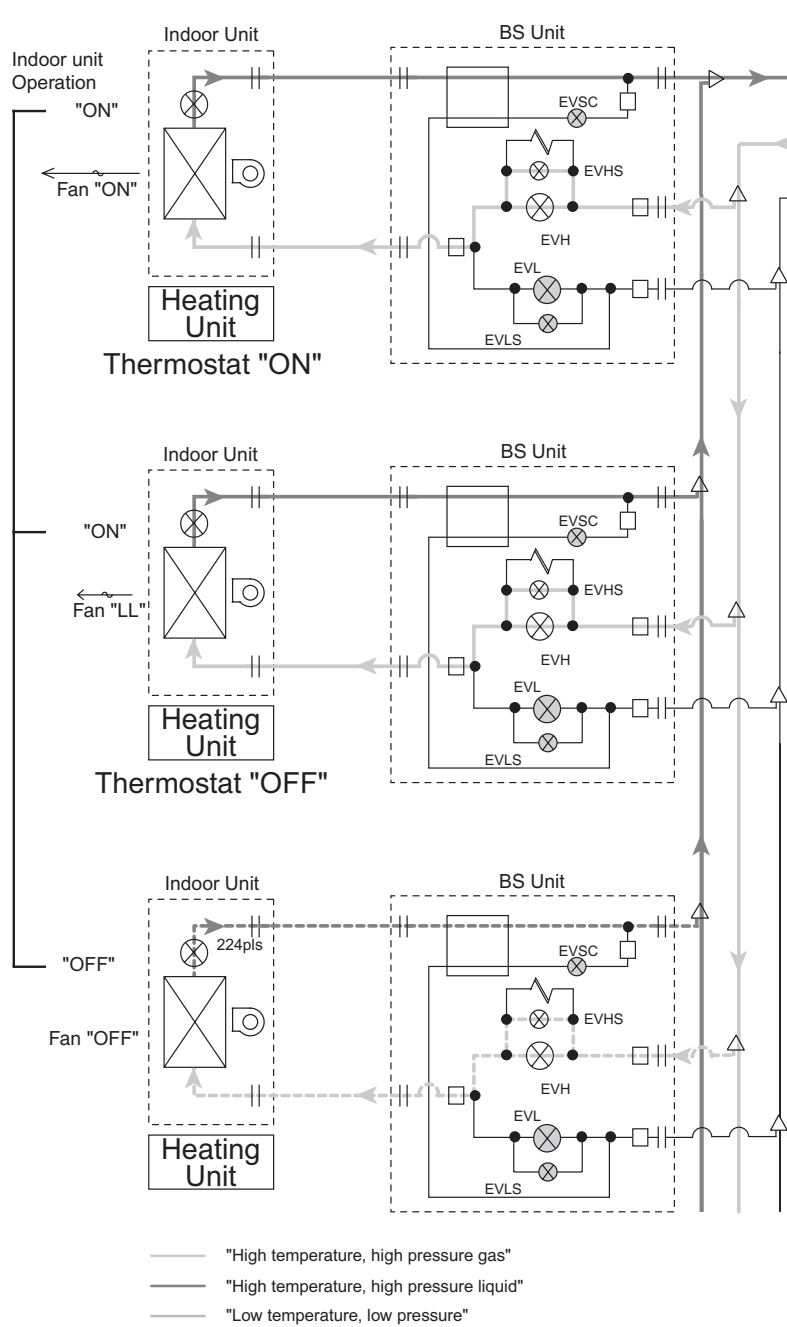

Heating Oil Return Operation

Oil Return Operation at Simultaneous Cooling / Heating Operation

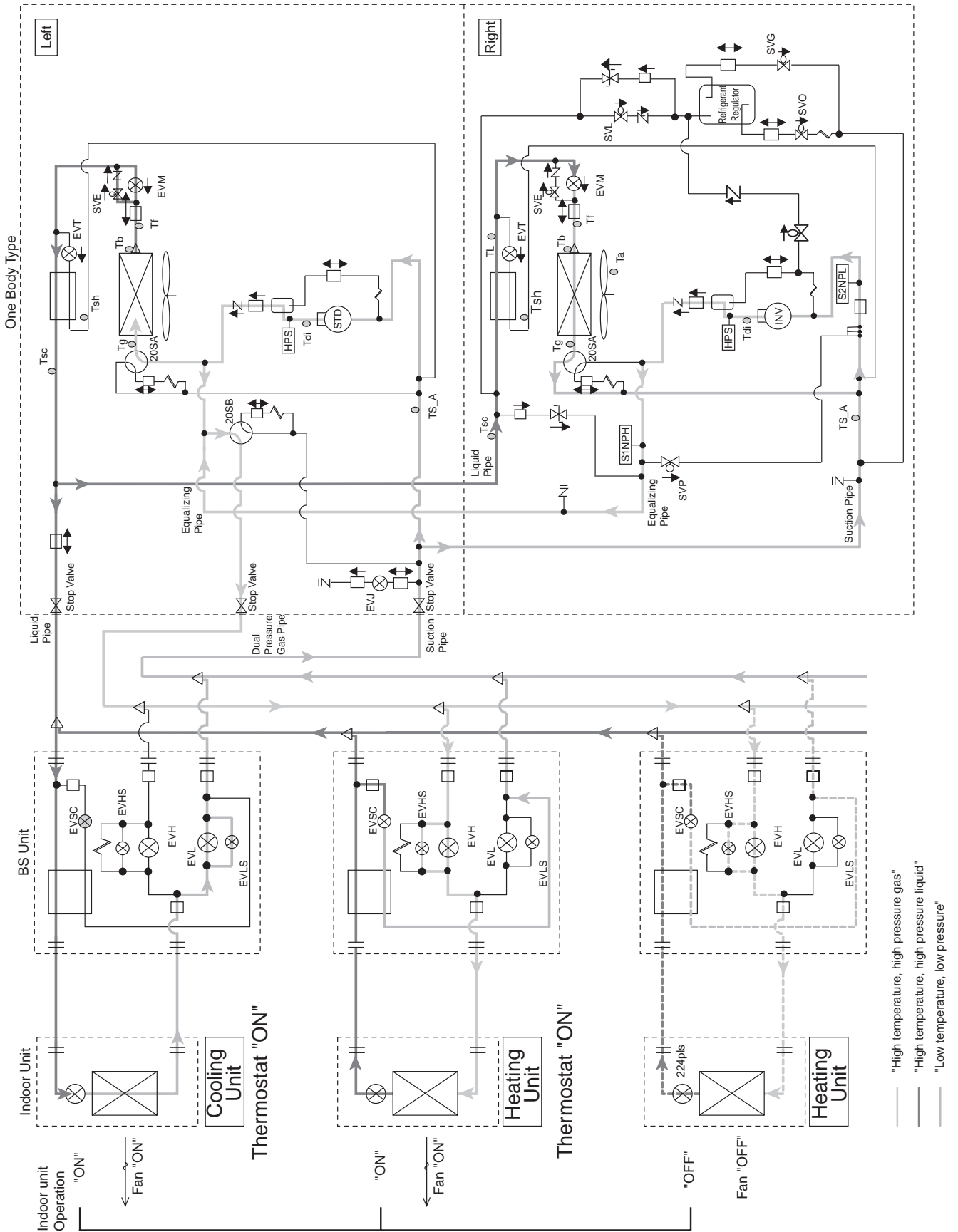

Partial Defrosting 2 (Defrosting in the Left Unit)

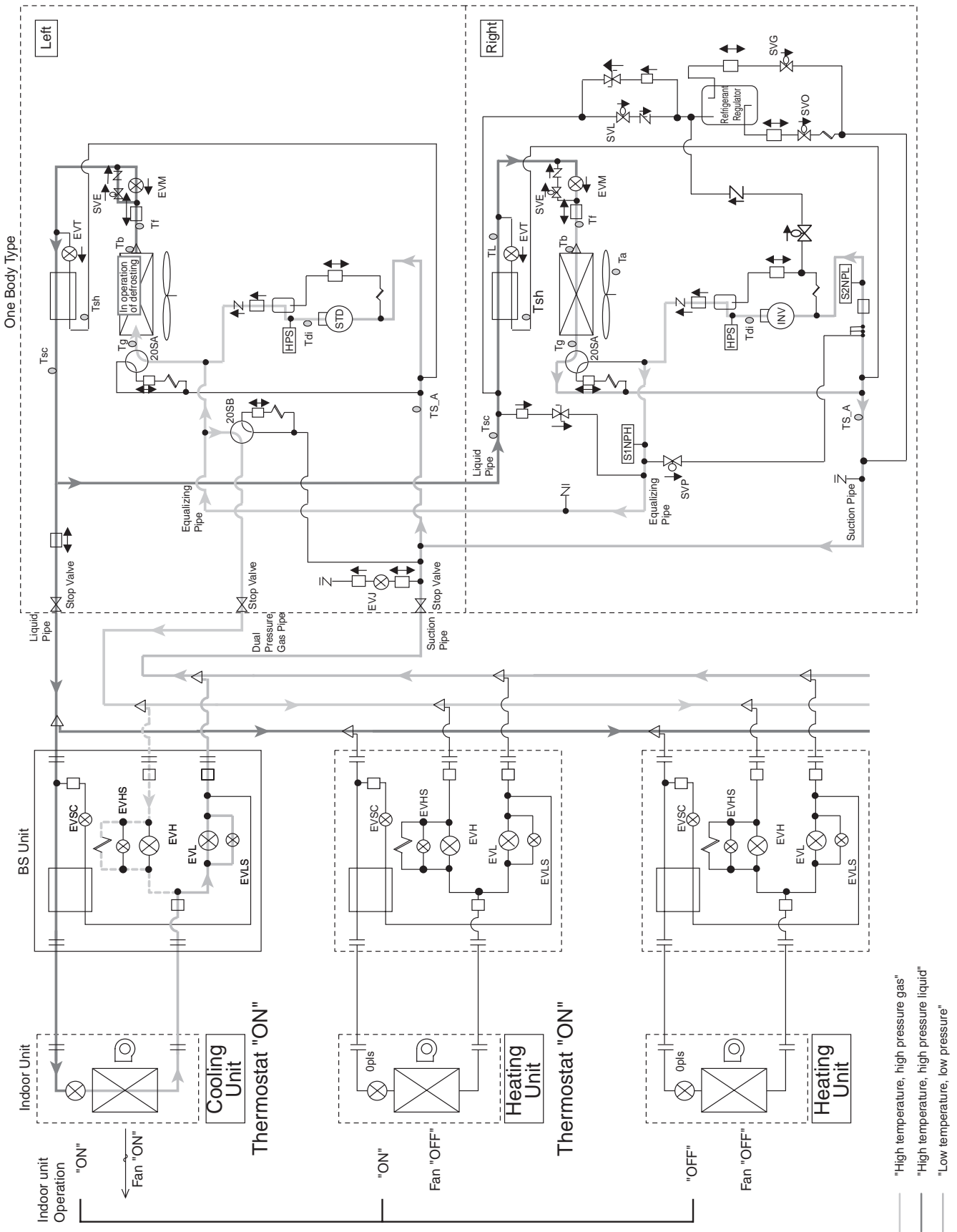

REYQ14P, 16P
Cooling Operation

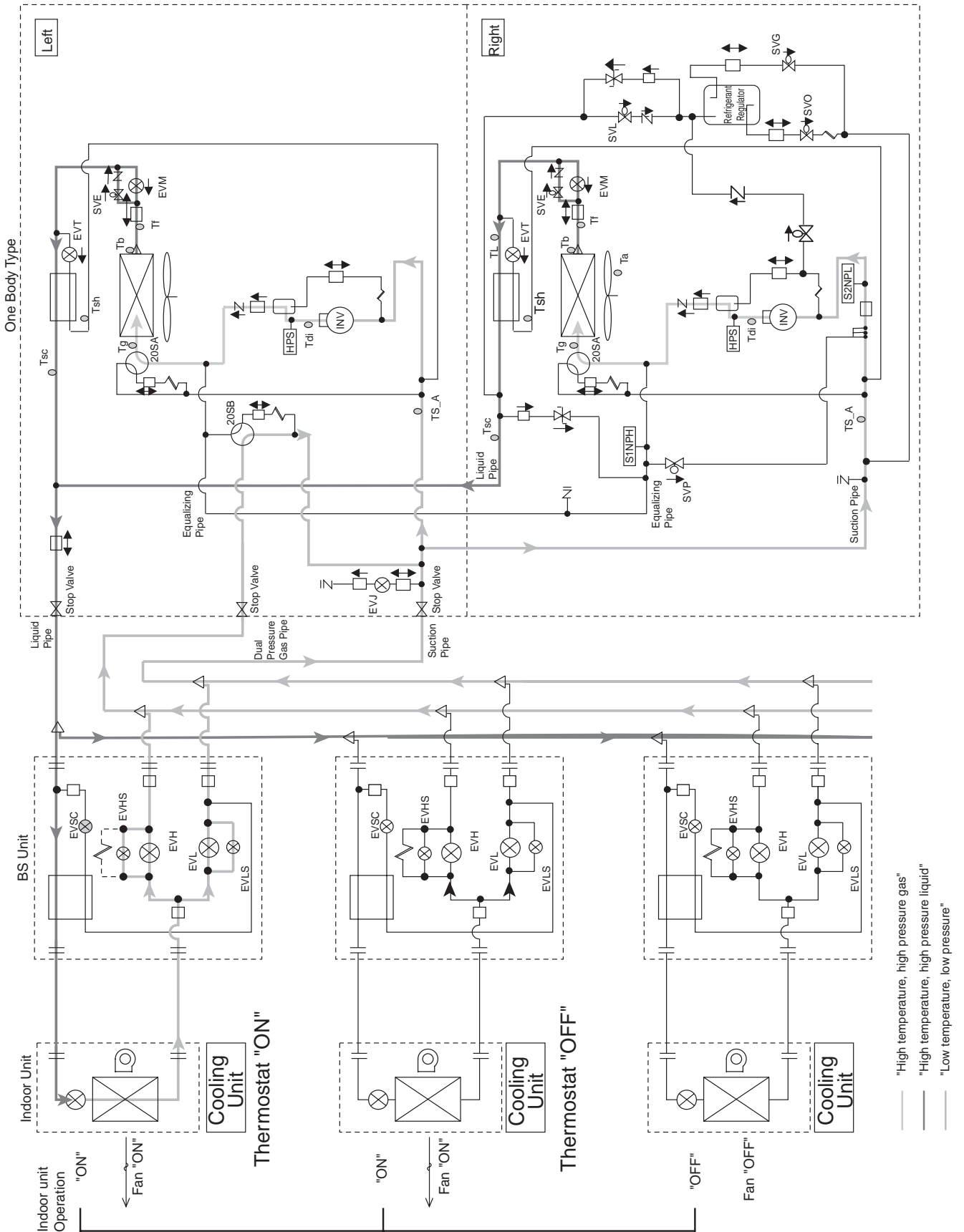

Heating Operation

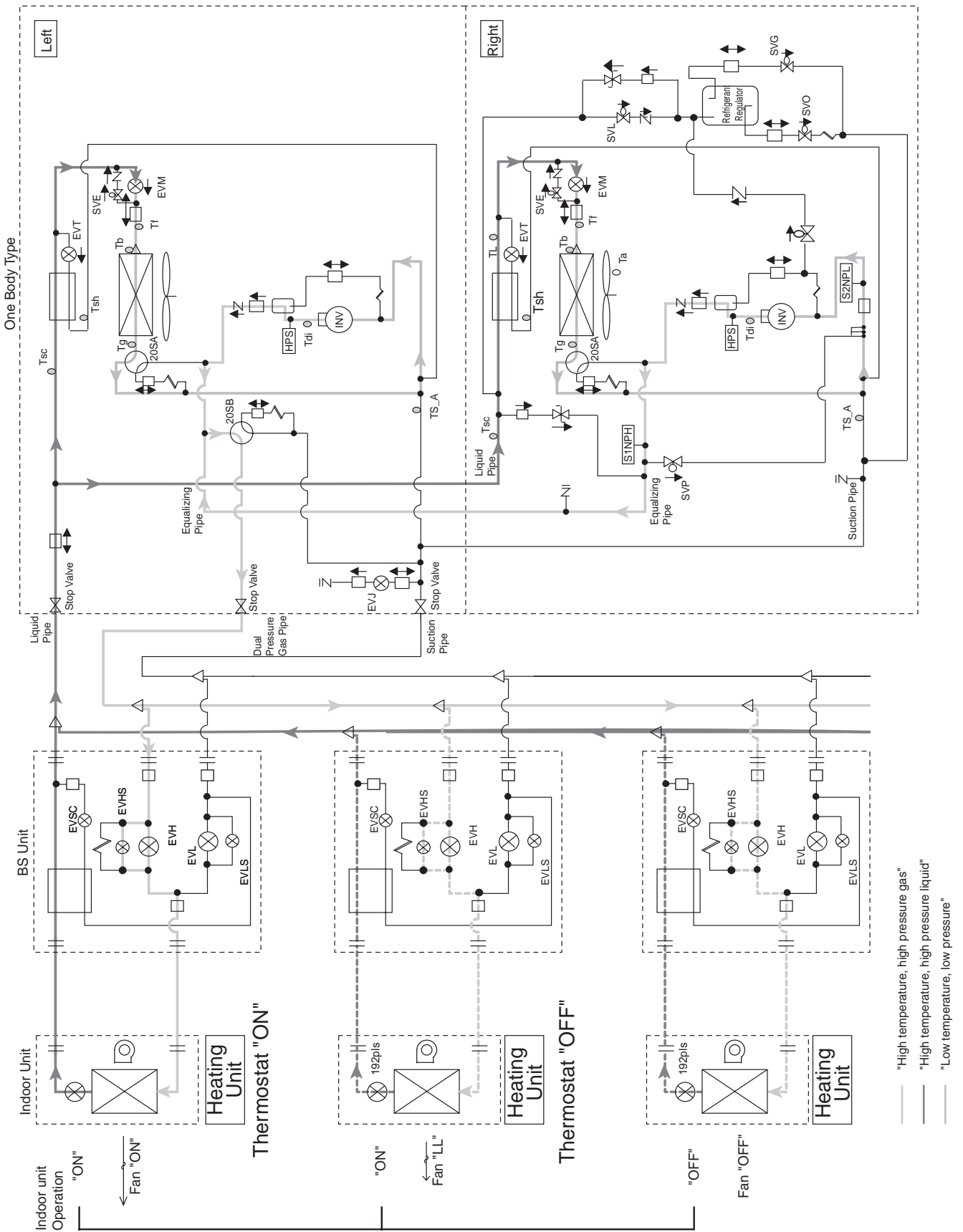

Cooling Oil Return Operation

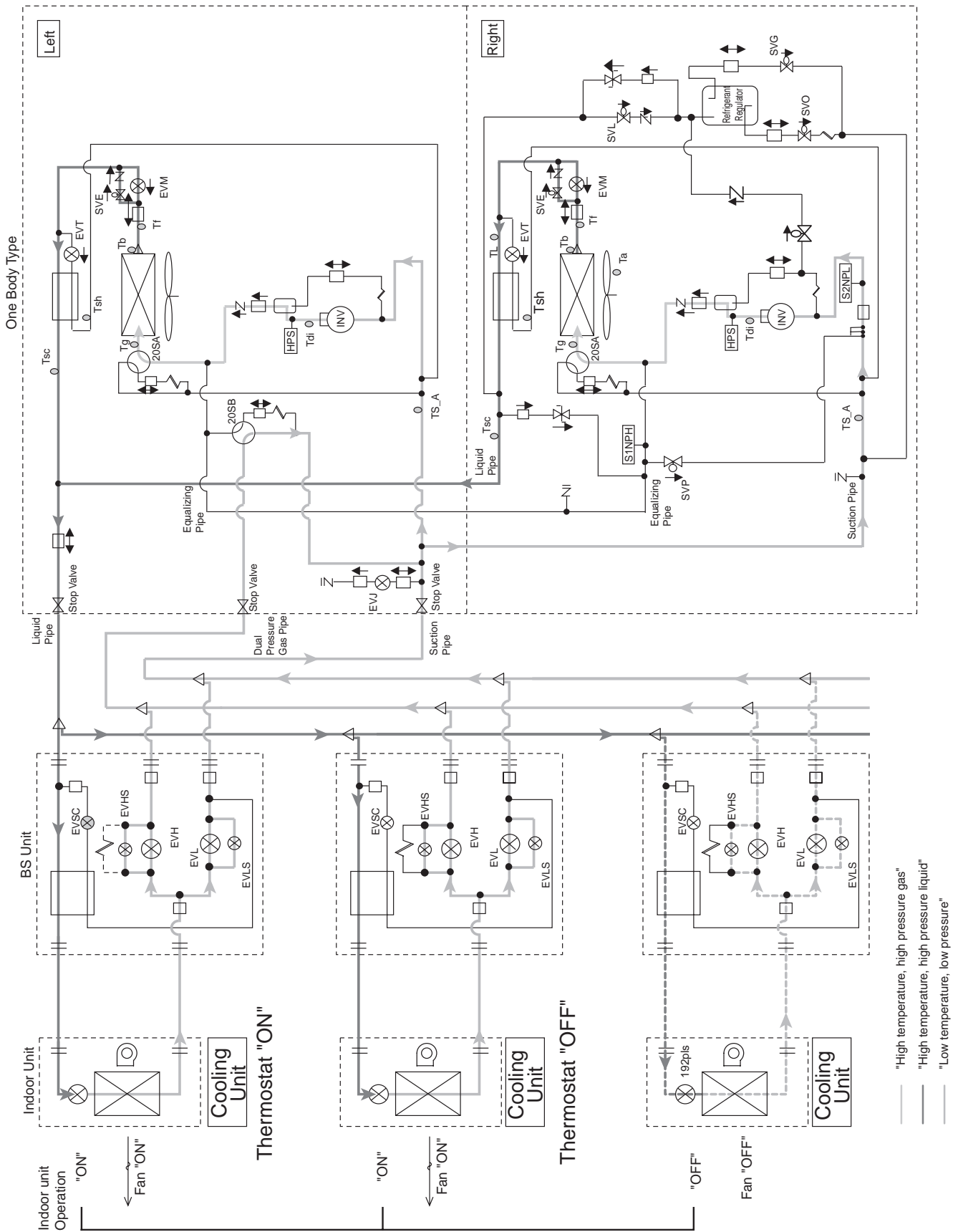

Heating Oil Return Operation

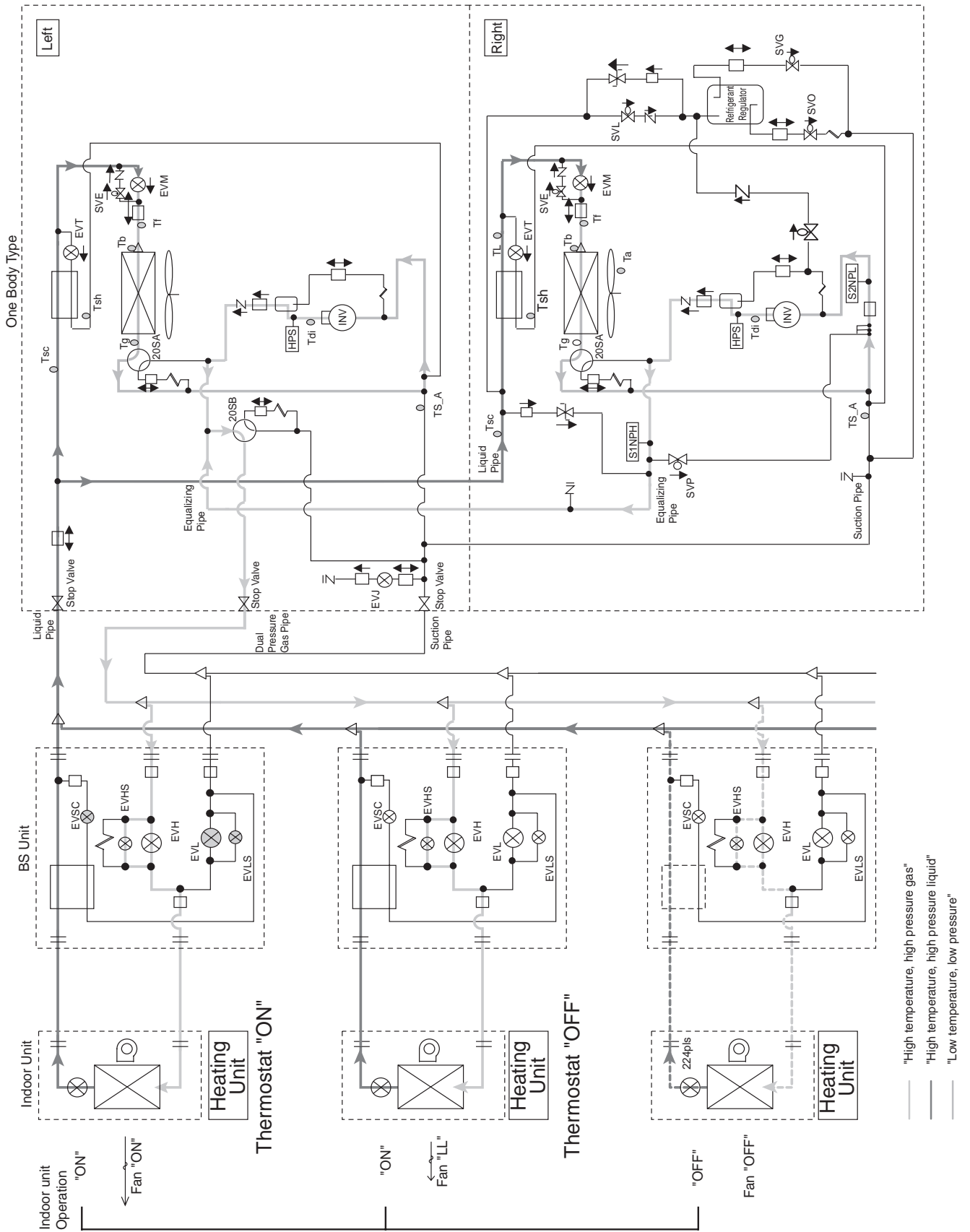

Oil Return Operation at Simultaneous Cooling / Heating Operation

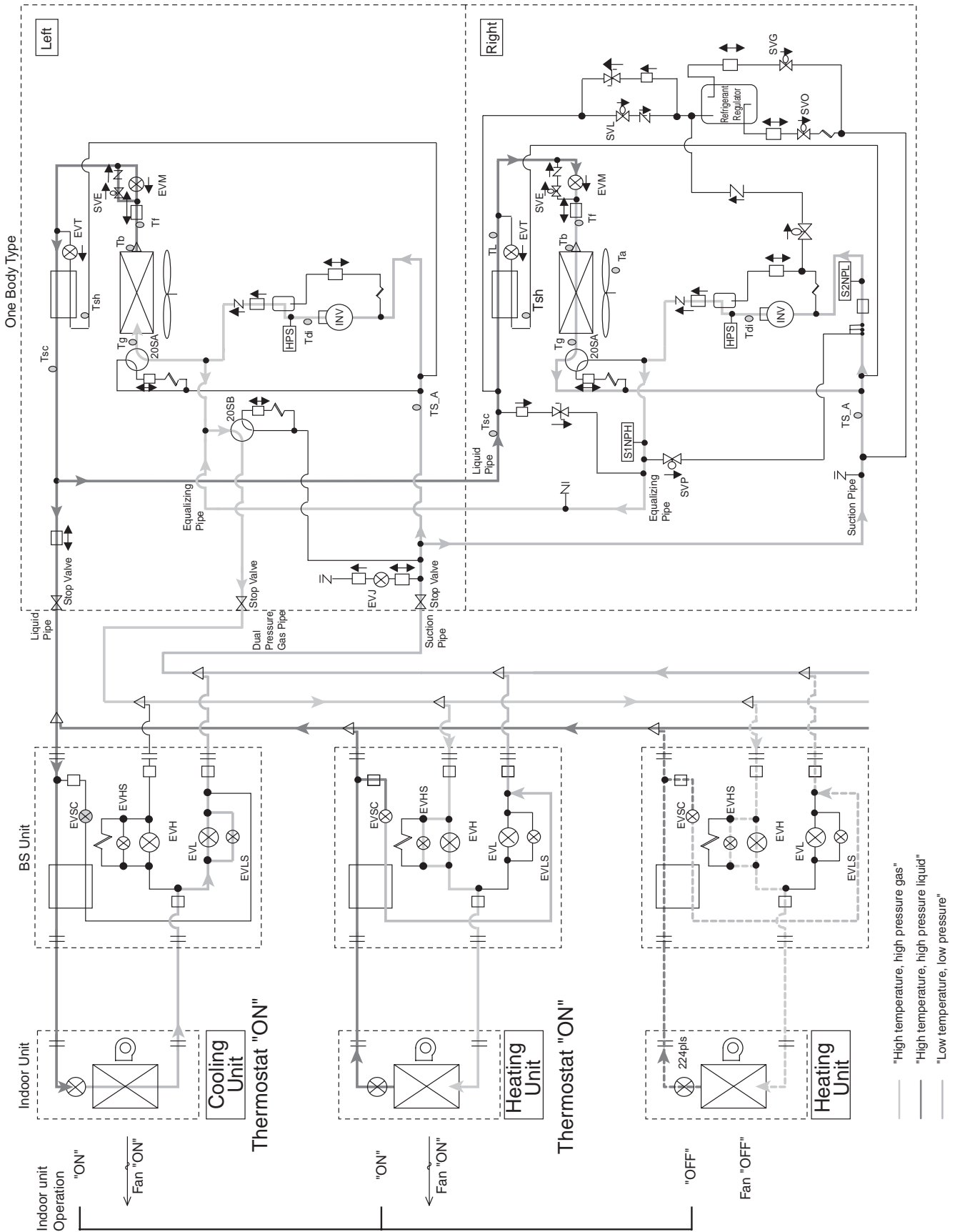

Partial Defrosting 1 (Defrosting in the Right Unit)

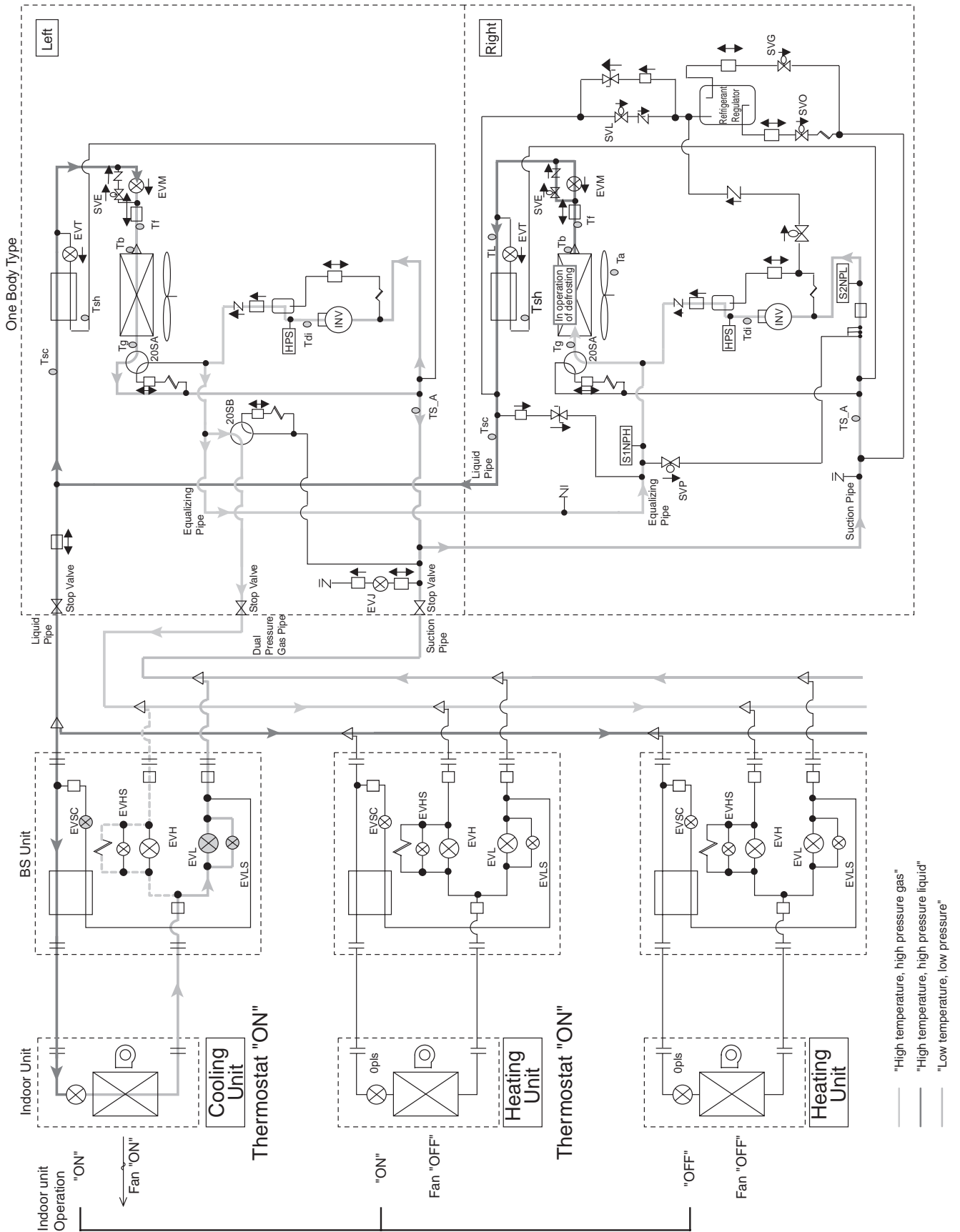

Partial Defrosting 2 (Defrosting in the Left Unit)

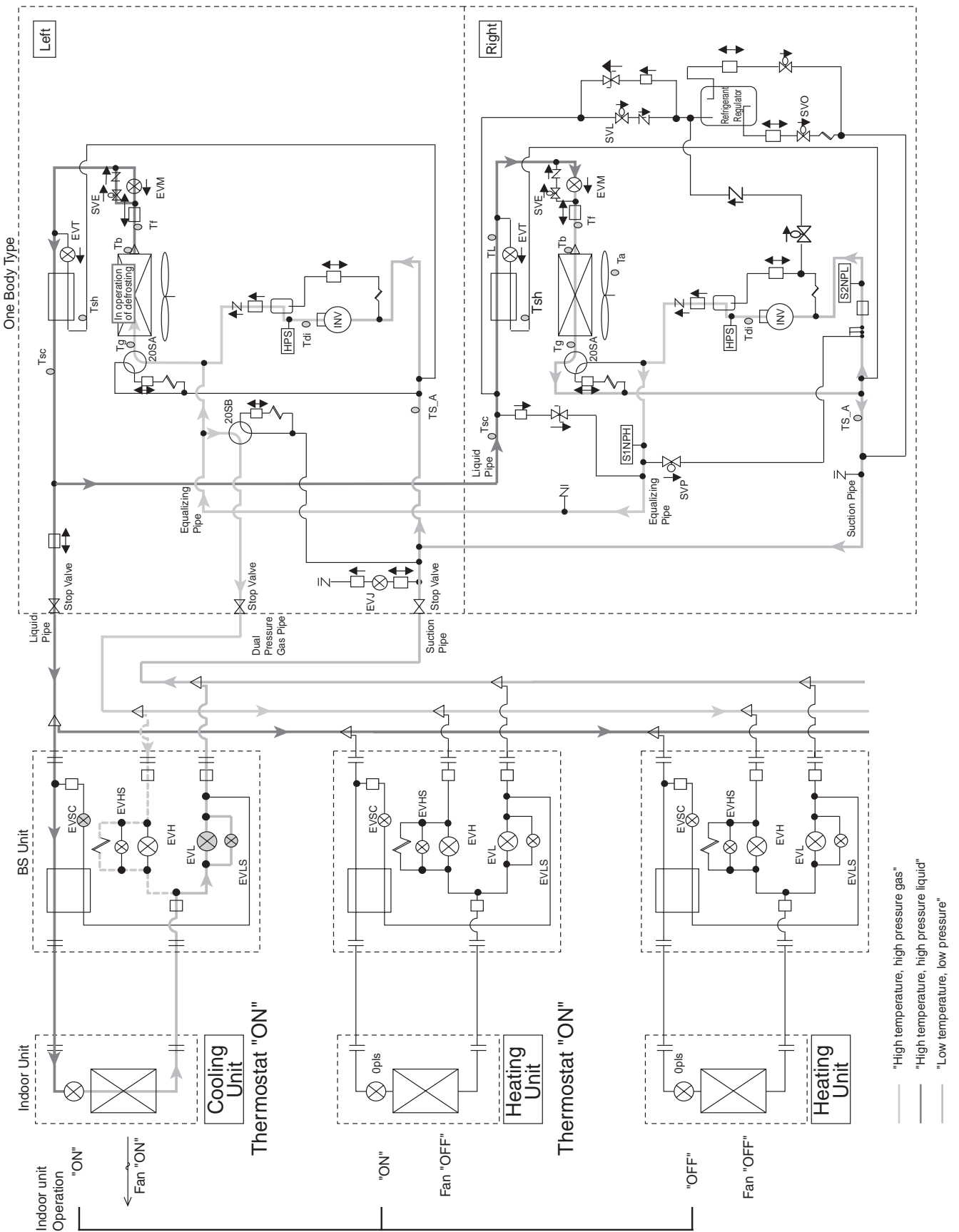

Cooling Oil Return Operation

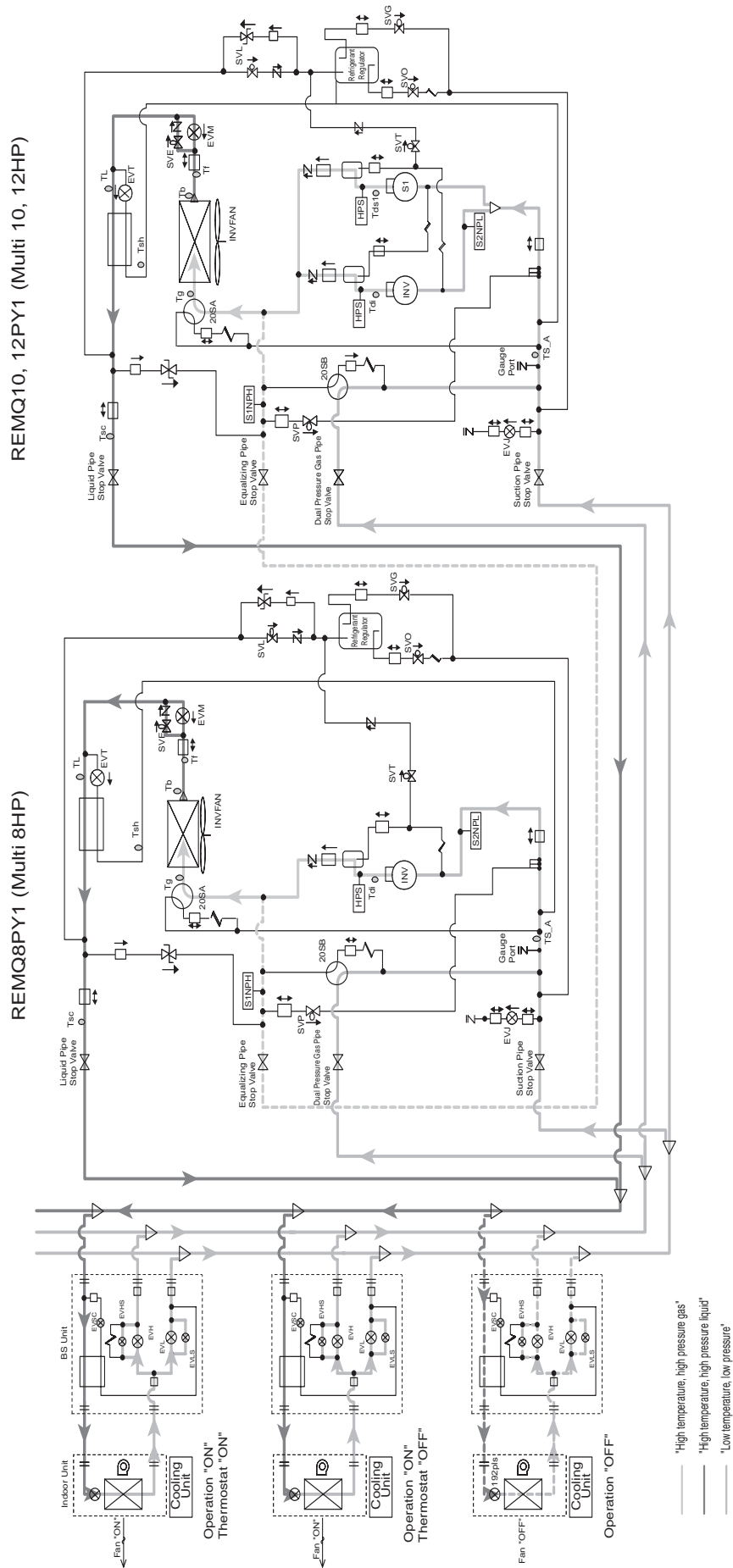

Partial Defrosting 1 (Defrosting in the Right Unit)

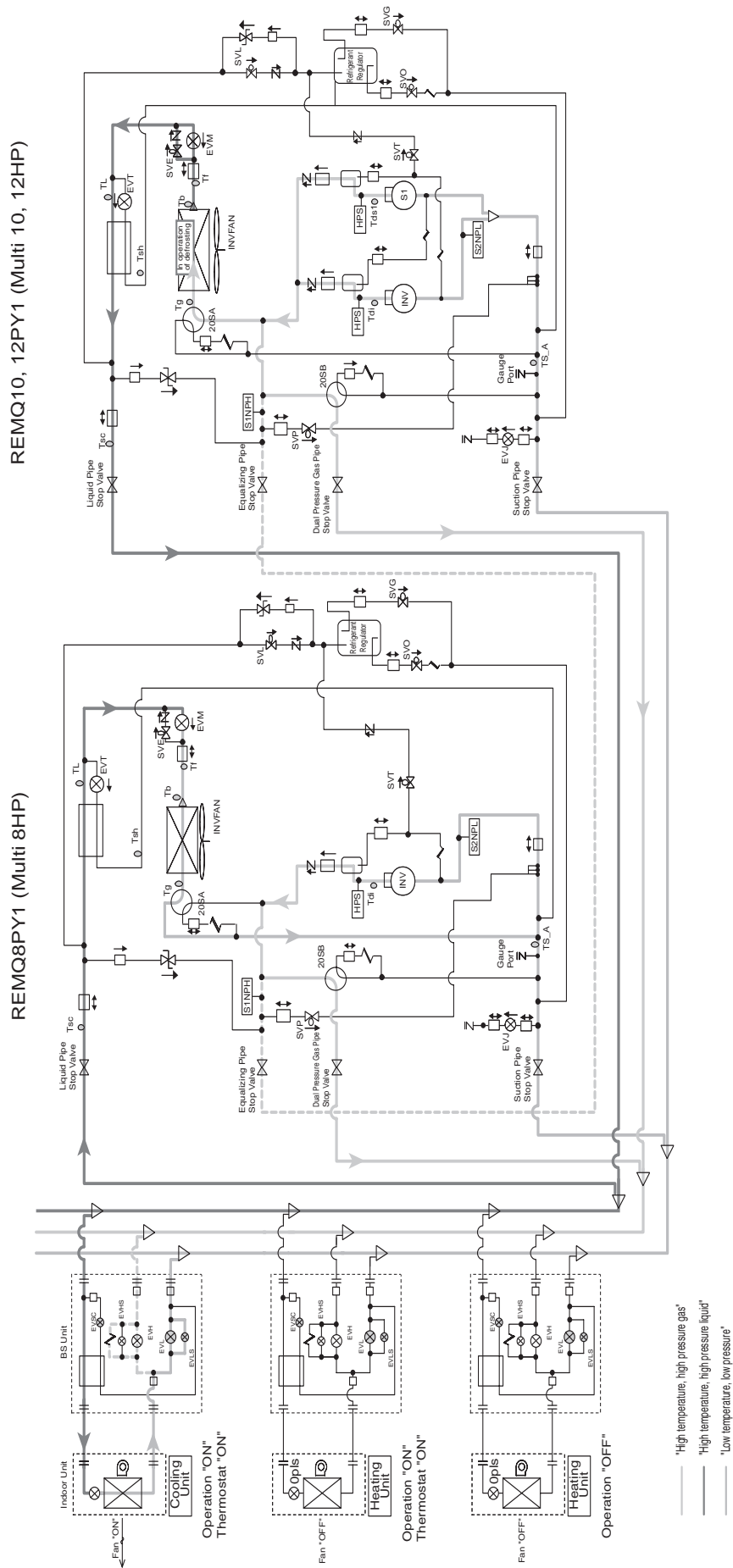

Partial Defrosting 2 (Defrosting in the Left Unit)

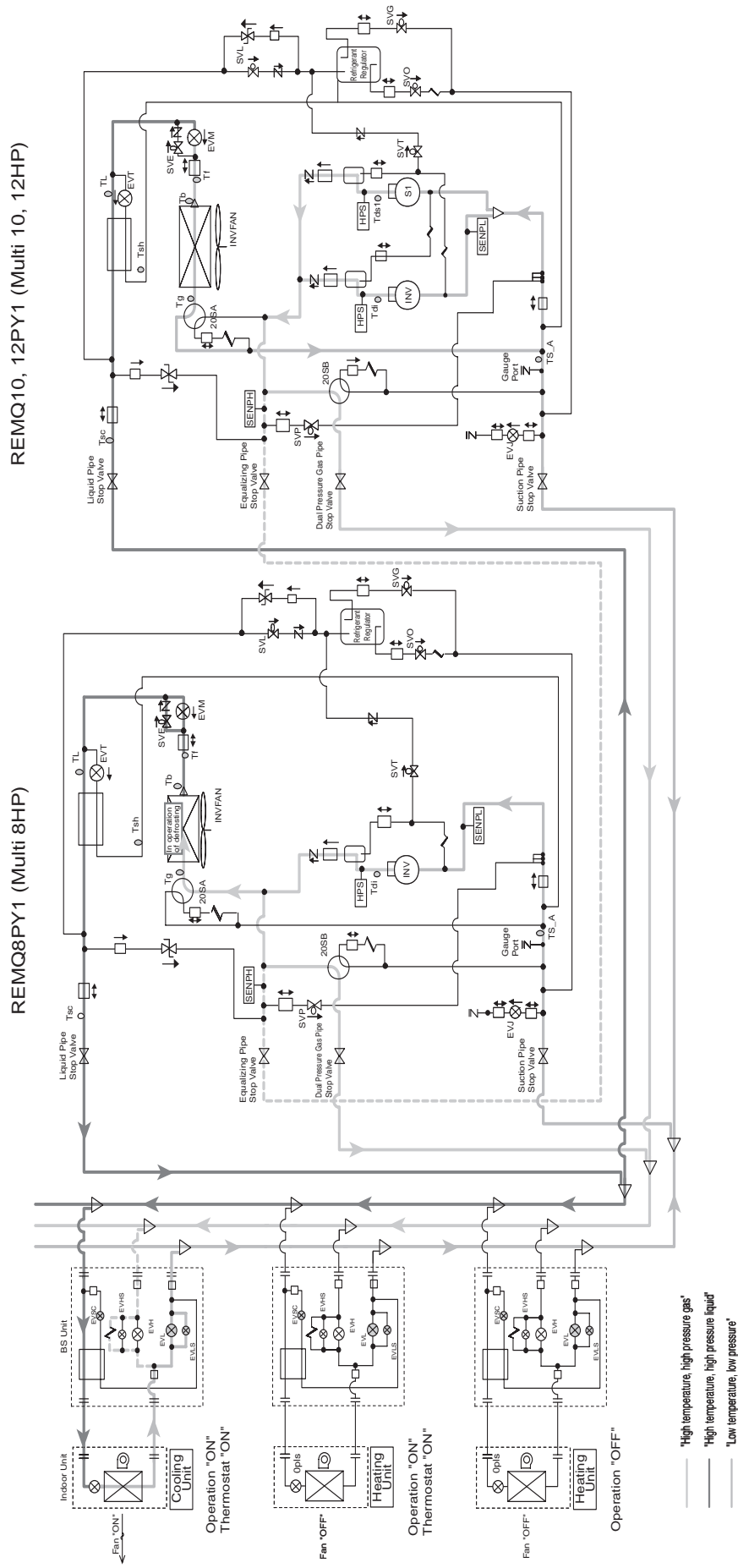

Operation of refrigerant regulator

1. Recovery of refrigerant

Surplus refrigerant is recovered to refrigerant regulator by opening of SVL and SVG when the indoor unit load is small.

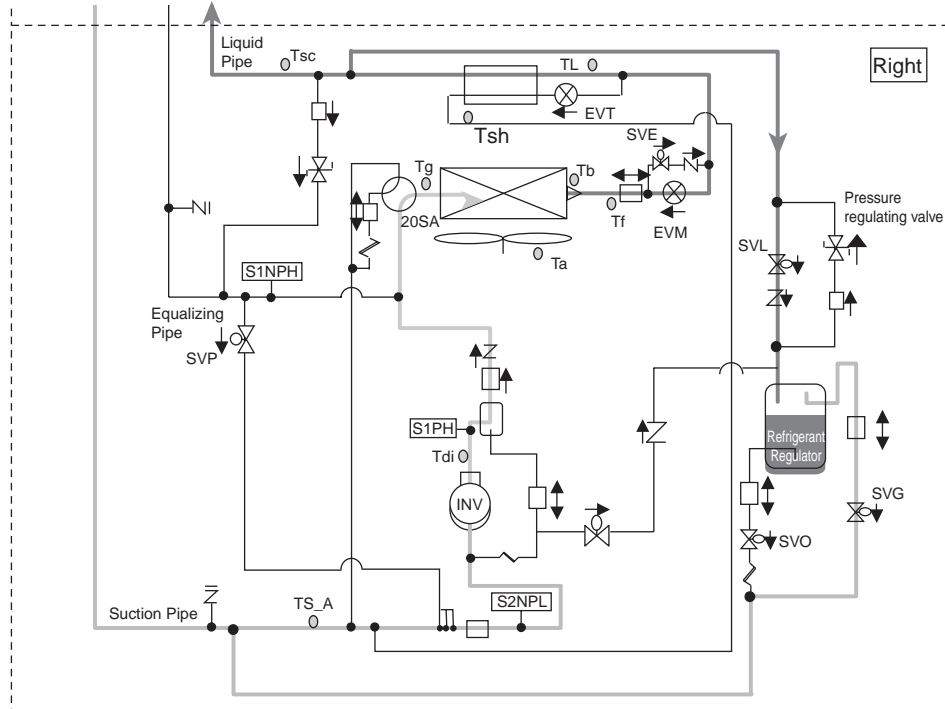

2. Discharge of refrigerant

Discharge refrigerant from refrigerant regulator by opening of SVC when the load of the outdoor unit is large.

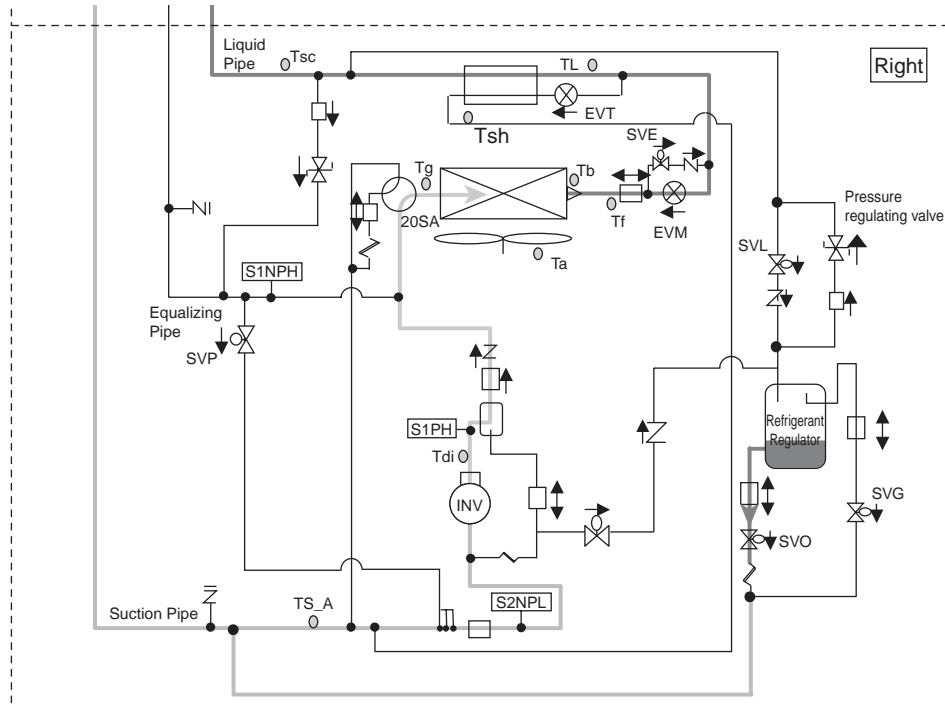

3. Pressure regulating valve (Refrigerant regulator)

The circuit will be closed when SVL, SVO, SVG are all closed. In this case, the increased pressure in the refrigerant regulator will be transferred to the liquid refrigerant pipe side, to regulate the pressure.

Pressure equalizing when switching operation cooling/ heating

1. When switching operation from to cooling to heating

First, the electric expansion valves for EVHS, EVH, EVL and EVLS of the indoor unit will be closed.

Next, open the EVHS, and it makes to balance the system pressure.

Finally, EVH and EVHS are opened and the electric expansion valve of the indoor unit is opened to start the operation as a heating circuit.

In cooling operation

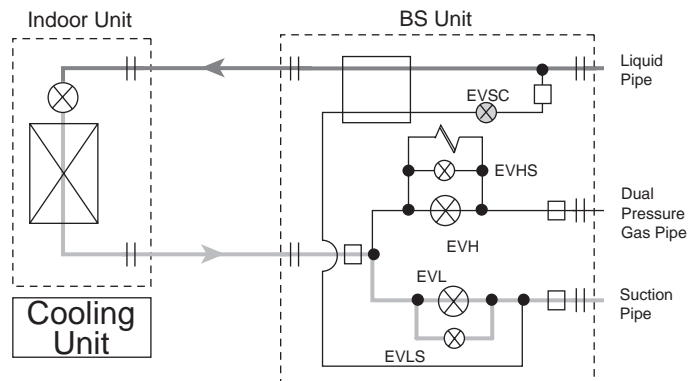

In equalization

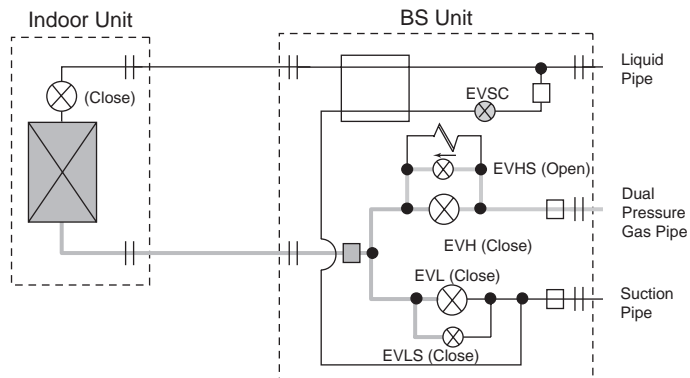

To heating operation

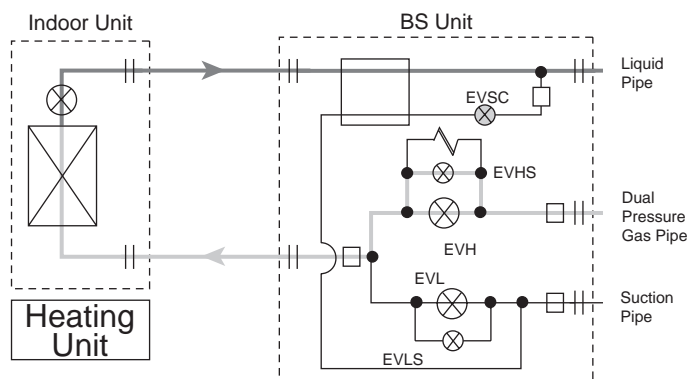

2. When switching operation from heating to cooling

First, the electric expansion valve and the solenoid valve for EVHS, EVH, EVL and EVLS of the indoor unit will be closed.

Next, open the EVLS, and it makes to balance the system pressure.

Finally, EVL and EVLS are opened and the electric expansion valve of the indoor unit is opened to start the operation as a cooling circuit.

In heating operation

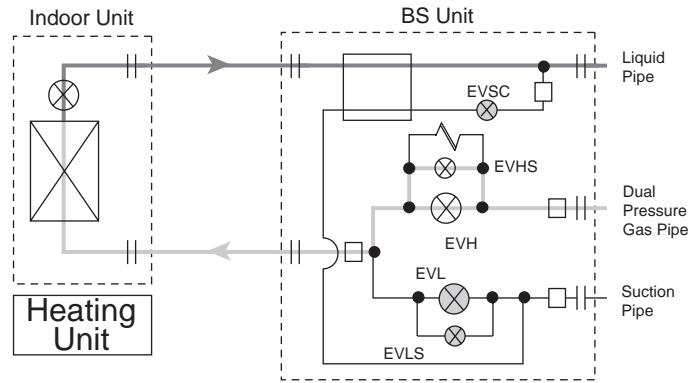

In equalization

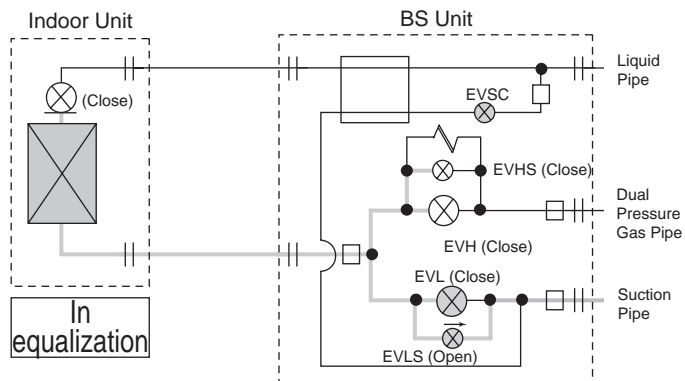

To cooling operation

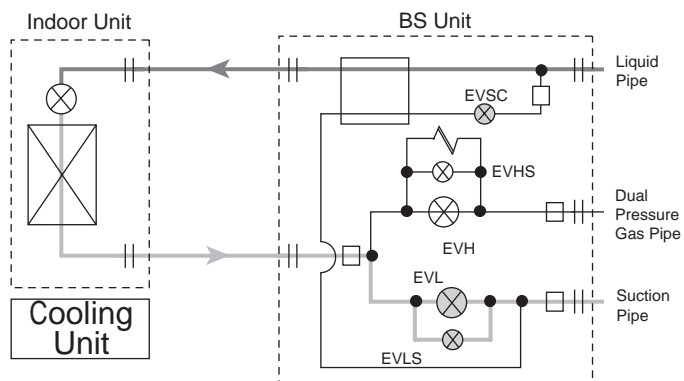

Part 4

Function

1. Function General.....	96
1.1 Symbol	96
1.2 Operation Mode.....	98
2. Basic Control	99
2.1 Normal Operation	99
2.2 Compressor PI Control	100
2.3 Electronic Expansion Valve PI Control.....	108
2.4 Step Control of Outdoor Unit Fans	108
2.5 Outdoor Unit Fan Control in Cooling Operation	109
2.6 Heat Exchanger Control	110
3. Special Control.....	111
3.1 Startup Control	111
3.2 Large Capacity Start Up Control (Heating).....	113
3.3 Oil Return Operation	114
3.4 Defrost Operation	118
3.5 Pump-down Residual Operation	120
3.6 Standby	122
3.7 Stopping Operation	123
4. Protection Control	124
4.1 High Pressure Protection Control.....	124
4.2 Low Pressure Protection Control.....	126
4.3 Discharge Pipe Protection Control	128
4.4 Inverter Protection Control	129
4.5 STD Compressor Overload Protection.....	131
5. Other Control.....	132
5.1 Backup Operation.....	132
5.2 Demand Operation	132
5.3 Heating Operation Prohibition	132
6. Outline of Control (Indoor Unit)	133
6.1 Operation Flow Chart	133
6.2 Thermostat Control.....	135
6.3 Drain Pump Control.....	139
6.4 Control of Electronic Expansion Valve	141
6.5 Freeze Prevention	142
6.6 Heater Control (Optional PC Board KRP1B...is required.).....	143
6.7 List of Swing Flap Operations	144
6.8 Hot Start Control (In Heating Operation Only).....	145
6.9 Louver Control for Preventing Ceiling Dirt.....	146

1. Function General

1.1 Symbol

Symbol	Electric symbol		Description or function
	REYQ8~16P	REMQ8~16P	
20SA	Y2S (Heat exchanger1)	Y3S	Four way valve (Heat exchanger switch)
	Y9S (Heat exchanger2)		
20SB	Y8S	Y2S	Four way valve (High/low pressure gas pipe switch)
DSH	–	–	Discharge pipe superheated degree
DSHi	–	–	Discharge pipe superheat of inverter compressor
DSHs	–	–	Discharge pipe superheat of standard compressor
EV	–	–	Opening of electronic expansion valve
EVM	Y1E (Main1)	Y1E	Electronic expansion valve for main heat exchanger
	Y3E (Main2)		
EVT	Y2E (Subcooling1)	Y3E	Electronic expansion valve for subcooling heat exchanger
	Y5E (Subcooling2)		
EVJ	Y4E	Y2E	Electronic expansion valve at the refrigerant charge port
HTDi	–	–	Value of INV compressor discharge pipe temperature compensated with outdoor air temperature
HTDs	–	–	Value of STD compressor discharge pipe temperature compensated with outdoor air temperature
Pc	S1NPH	S1NPH	Value detected by high pressure sensor
Pe	S2NPL	S2NPL	Value detected by low pressure sensor
SH	–	–	Evaporator outlet superheat
SHS	–	–	Target evaporator outlet superheat
SVE	Y5S (Bypass1)	Y6S	Main bypass solenoid valve
	Y10S (Bypass2)		
SVP	Y4S	Y5S	Solenoid valve for hot gas
SVL	Y3S	Y4S	Refrigerant regulator liquid pipe solenoid valve
SVG	Y1S	Y1S	Refrigerant regulator gas pipe solenoid valve
SVO	Y7S	Y7S	Refrigerant regulator exhaust pipe solenoid valve
SVT	Y6S	Y8S	Refrigerant regulator discharge pipe solenoid valve

Symbol	Electric symbol		Description or function
	REYQ8~16P	REMQ8~16P	
Ta	R1T (A1P)	R1T (A1P)	Outdoor air temperature
TsA	R8T (Suction pipe1)	R8T	Suction pipe temperature
	R10T (Suction pipe2)		
Tb	R4T (Deicer1)	R4T	Heat exchanger outlet temperature at cooling
	R12T (Deicer2)		
Tg	R2T (Gas pipe1)	R2T	Heat exchanger gas pipe temperature
	R11T (Gas pipe2)		
Tf	R7T (Liquid pipe1)	R7T	Temperature of liquid pipe between heat exchanger and main electronic expansion valve
	R15T (Liquid pipe2)		
Tsh	R5T (Gas pipe1)	R5T	Temperature detected with the subcooling heat exchanger outlet thermistor
	R13T (Gas pipe2)		
Tl	R6T (Liquid pipe1)	R6T	Liquid pipe temperature detected with the liquid pipe thermistor
	R14T (Liquid pipe2)		
Tsc	R9T	R9T	Temperature of liquid pipe between liquid shutoff valve and supercooled heat exchanger
Tc	–	–	High pressure equivalent saturation temperature
TcS	–	–	Target temperature of Tc
Te	–	–	Low pressure equivalent saturation temperature
TeS	–	–	Target temperature of Te
Tfin	R1T (A4P) (A5P)	R1T (A3P)	Inverter fin temperature
Tp	–	–	Calculated value of compressor port temperature
Tdi	R31T (R32T)	R31T	Discharge pipe temperature of inverter compressor
Tds	R32T	R32T, R33T	Discharge pipe temperature of standard compressor

1.2 Operation Mode

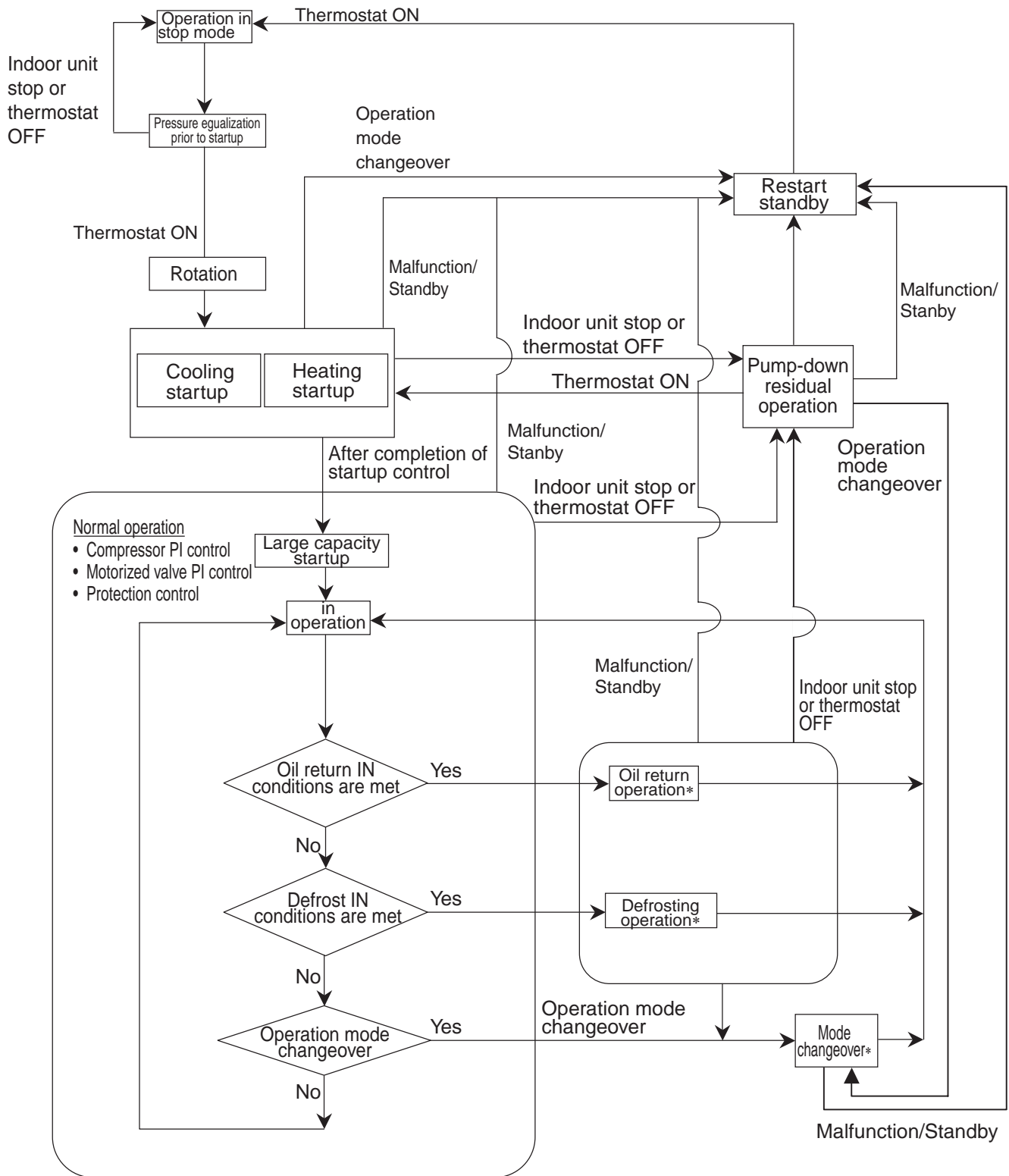

* "Oil return", "Defrost" and "Mode changeover" move on to the next process after the completion of above function in progress even if the thermostat is OFF during the operation.

2. Basic Control

2.1 Normal Operation

2.1.1 List of Functions in Normal Operation

Part Name	Symbol	(Electric Symbol)		Function of Functional Part		
		REYQ	REMQ	Normal Cooling	Normal Heating	Normal Simultaneous Cooling / Heating
Compressor 1	—	M1C	M1C	PI control, High pressure protection, Low pressure protection, Td protection, INV protection,	PI control, High pressure protection, Low pressure protection, Td protection, INV protection,	PI control, High pressure protection, Low pressure protection, Td protection, INV protection,
Compressor 2		M2C	M2C			
Compressor 3		—	M3C			
Outdoor unit fan 1	—	M1F	M1F	Cooling fan control	Outdoor unit heat exchanger: Condenser / Cooling fan control Outdoor unit heat exchanger: Evaporator / Fan step	Outdoor unit heat exchanger: Condenser / Cooling fan control Outdoor unit heat exchanger: Evaporator / Fan step
Outdoor unit fan 2		M2F	M2F			
Electronic expansion valve (Main)	EVM	Y1E	Y1E	1375 pls	Outdoor unit heat exchanger: Condenser / Liquid pressure control Outdoor unit heat exchanger: Evaporator / PI control	Outdoor unit heat exchanger: Condenser / Liquid pressure control Outdoor unit heat exchanger: Evaporator / PI control
		Y3E				
Electronic expansion valve (Supercooling)	EVT	Y2E Y5E	Y3E	PI control	PI control	PI control
Electronic expansion valve (Refrigerant charge)	EVJ	Y4E	Y2E	80 pls	80 pls	80 pls
Four way valve (Heat exchanger switch)	20SA	Y2S	Y3S	OFF	Outdoor unit heat exchanger: Condenser / OFF Outdoor unit heat exchanger: Evaporator / ON	Outdoor unit heat exchanger: Condenser / OFF Outdoor unit heat exchanger: Evaporator / ON
		Y9S				
Four way valve (High/low pressure gas pipe switch)	20SB	Y8S	Y2S	ON	OFF	OFF
Solenoid valve (Main bypass)	SVE	Y5S	Y6S	ON	OFF	OFF
		Y10S				
Solenoid valve (Hot gas)	SVP	Y4S	Y5S	OFF	OFF	OFF
Solenoid valve (Refrigerant regulator liquid pipe)	SVL	Y3S	Y4S	ON for refrigerant recovery	ON for refrigerant recovery	ON for refrigerant recovery
Solenoid valve (Refrigerant regulator gas vent pipe)	SVG	Y1S	Y1S	ON for refrigerant recovery	ON for refrigerant recovery	ON for refrigerant recovery
Solenoid valve (Refrigerant regulator exhaust pipe)	SVO	Y7S	Y7S	ON for refrigerant discharge	ON for refrigerant discharge	ON for refrigerant discharge
Solenoid valve (Refrigerant regulator discharge pipe)	SVT	Y6S	Y8S	ON for oil level control	ON for oil level control	ON for oil level control

Indoor unit actuator		Normal cooling	Normal heating
Fan	Thermostat ON unit	Remote control setting	Remote control setting
	Stopping unit	OFF	OFF
	Thermostat OFF unit	Remote control setting	LL
Electronic expansion valve	Thermostat ON unit	Normal opening *1	Normal opening *2
	Stopping unit	0 pls	192 pls
	Thermostat OFF unit	0 pls	192 pls

*1. PI control : Evaporator outlet superheated degree (SH) constant.

*2. PI control : Condenser outlet subcooled degree (SC) constant.

*1 and 2 : Refer to "6.4 Control of Electronic Expansion Valve" on page 141.

BS unit actuator	Electric symbol	Normal cooling	Normal heating / Normal simultaneous Cooling / Heating operation
Electronic expansion valve (EVH)	Y4E	760 pls (fully opened)	760 pls (fully opened)
Electronic expansion valve (EVL)	Y5E	760 pls (fully opened)	0 pls
Electronic expansion valve (EVHS)	Y2E	480 pls (fully opened)	480 pls (fully opened)
Electronic expansion valve (EVLS)	Y3E	480 pls (fully opened)	0 pls
Electronic expansion valve (EVSC)	Y1E	0 pls	0 pls (simultaneous Cooling / Heating operation : PI control)

2.2 Compressor PI Control

Compressor PI Control

Carries out the compressor capacity PI control to maintain Te at constant during cooling operation and Tc at constant during heating operation to ensure stable unit performance.

[Cooling operation]

Controls compressor capacity to adjust Te to achieve target value (TeS).

Te set value (Make this setting while in Setting mode 2.)

Te setting

L	M (Normal) (factory setting)	H				
3	6	7	8	9	10	11

Te : Low pressure equivalent saturation temperature (°C)

TeS : Target Te value
(Varies depending on Te setting, operating frequency, etc.)

*On multi-outdoor-unit systems, this control is made according to values of the first-priority unit, which is detected with the pressure sensor.

[Heating operation]

Controls compressor capacity to adjust Tc to achieve target value (TcS).

Tc set value (Make this setting while in Setting mode 2.)

Tc setting

L	M (Normal) (factory setting)	H
43	46	48

Tc : High pressure equivalent saturation temperature (°C)

TcS : Target Tc value
(Varies depending on Tc setting, operating frequency, etc.)

*On multi-outdoor-unit systems, this control is made according to values of the first-priority unit, which is detected with the pressure sensor.

Rotation of outdoor units

In order to make operating time equal for each compressor of multi connection outdoor units, outdoor units are used in rotation.

However this is not applicable to single units.

[Rotation of outdoor units]

[System with two outdoor units]

	Outdoor Unit 1	Outdoor Unit 2
Previous time	Priority 1	Priority 2
This time	Priority 2	Priority 1
Next time	Priority 1	Priority 2

[System with three outdoor units]

	Outdoor Unit 1	Outdoor Unit 2	Outdoor Unit 3
Previous time	Priority 1	Priority 2	Priority 3
This time	Priority 3	Priority 1	Priority 2
Next time	Priority 2	Priority 3	Priority 1
One time after the next	Priority 1	Priority 2	Priority 3

[Timing of outdoor rotation]

In start of startup control

■ Operating Priority and Rotation of Compressors

Each compressor operates in the following order of priority. In the case of multi-outdoor-unit system, each compressor operates in any of Pattern 1 through Pattern 3 according to the rotation of outdoor units.

INV: Inverter compressor
 STD1: Standard compressor 1
 STD2: Standard compressor 2

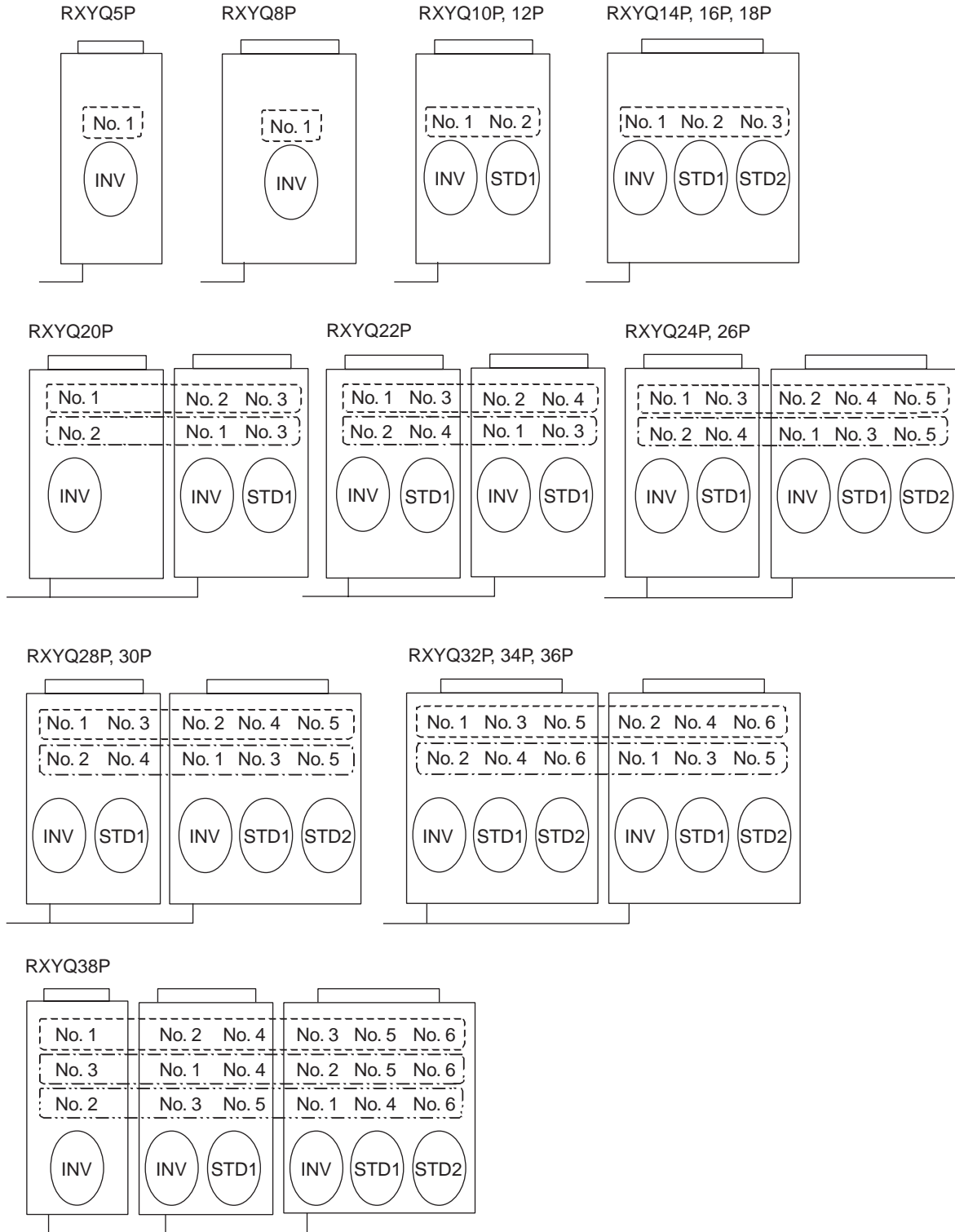

REYQ38P, 40P

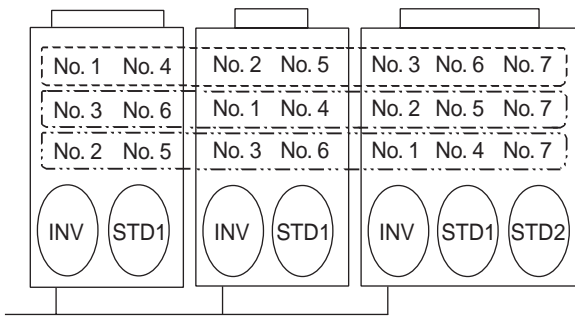

REYQ42P, 44P

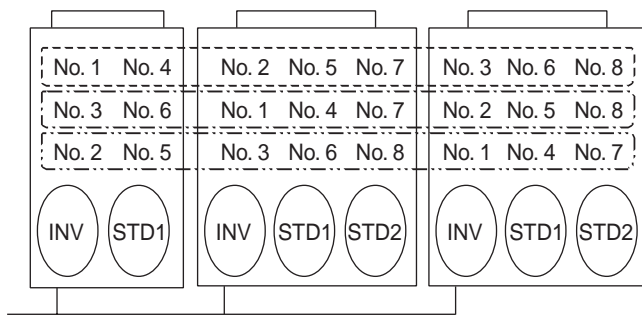

REYQ46P, 48P

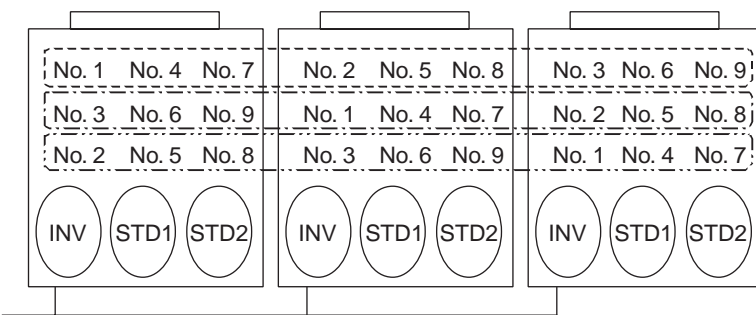

- *
- In the case of combination of 3 outdoor units, the above diagram shows master unit, slave unit 1, and slave unit 2 from left to right.
 - Compressors may operate in any pattern other than those mentioned above according to the operating status.

■ Compressor Step Control

Compressor operations vary with the following steps according to information in "2.2 Compressor PI Control".

Furthermore, the operating priority of compressors is subject to information in "■ Operating Priority and Rotation of Compressors".

Single unit installation

REYQ8PY1, 10PY1, 12PY1

STEP No.	INV	STD1
1	52Hz	
2	56Hz	
3	62Hz	
4	68Hz	
5	74Hz	
6	80Hz	
7	88Hz	
8	96Hz	
9	104Hz	
10	110Hz	
11	116Hz	
12	124Hz	
13	132Hz	
14	144Hz	
15	158Hz	
16	166Hz	
17	176Hz	
18	188Hz	
19	202Hz	
20	210Hz	
21	52Hz	ON
22	62Hz	ON
23	68Hz	ON
24	74Hz	ON
25	80Hz	ON
26	88Hz	ON
27	96Hz	ON
28	104Hz	ON
29	116Hz	ON
30	124Hz	ON
31	132Hz	ON
32	144Hz	ON
33	158Hz	ON
34	176Hz	ON
35	188Hz	ON
36	202Hz	ON
37	210Hz	ON

← Initial step

←REYQ8PY1 upper limit

REYQ14PY1, 16PY1

STEP No.	INV1	INV2
1	52Hz	52Hz
2	56Hz	56Hz
3	62Hz	62Hz
4	66Hz	66Hz
5	70Hz	70Hz
6	74Hz	74Hz
7	80Hz	80Hz
8	88Hz	88Hz
9	92Hz	92Hz
10	96Hz	96Hz
11	104Hz	104Hz
12	110Hz	110Hz
13	116Hz	116Hz
14	124Hz	124Hz
15	132Hz	132Hz
16	144Hz	144Hz
17	158Hz	158Hz
18	166Hz	166Hz
19	176Hz	176Hz
20	188Hz	188Hz
21	202Hz	202Hz
22	210Hz	210Hz
23	218Hz	218Hz
24	232Hz	232Hz
25	248Hz	248Hz
26	266Hz	266Hz

← Initial step

Notes:

1. INV : Inverter compressor
STD1 : Standard compressor 1
STD2 : Standard compressor 2
2. Depending on the operating conditions of compressors, the compressors may run in patterns other than those aforementioned.

Two-unit multi system

REYQ18PY1, 20PY1 (8+10/12HP)

(To increase Step No.)

STEP No.	unit 1 INV	unit 2 INV	STD
1	52Hz	52Hz	←Initial step
2	56Hz	56Hz	
3	62Hz	62Hz	
4	66Hz	66Hz	
5	70Hz	70Hz	
6	74Hz	74Hz	
7	80Hz	80Hz	
8	88Hz	88Hz	
9	92Hz	92Hz	
10	96Hz	96Hz	
11	104Hz	104Hz	
12	110Hz	110Hz	
13	116Hz	116Hz	
14	124Hz	124Hz	
15	132Hz	132Hz	
16	144Hz	144Hz	
17	158Hz	158Hz	
18	166Hz	166Hz	
19	176Hz	176Hz	
20	80Hz	80Hz	ON
21	88Hz	88Hz	ON
22	96Hz	96Hz	ON
23	104Hz	104Hz	ON
24	116Hz	116Hz	ON
25	124Hz	124Hz	ON
26	132Hz	132Hz	ON
27	144Hz	144Hz	ON
28	158Hz	158Hz	ON
29	176Hz	176Hz	ON
30	188Hz	188Hz	ON
31	202Hz	202Hz	ON
32	210Hz	210Hz	ON

(To decrease Step No.)

STEP No.	unit 1 INV	unit 2 INV	STD
1	52Hz		
2	56Hz		
3	62Hz		
4	68Hz		
5	74Hz		
6	80Hz		
7	88Hz		
8	96Hz		
9	104Hz		
10	52Hz	52Hz	
11	56Hz	56Hz	
12	62Hz	62Hz	
13	66Hz	66Hz	
14	70Hz	70Hz	
15	74Hz	74Hz	
16	80Hz	80Hz	
17	88Hz	88Hz	
18	92Hz	92Hz	
19	96Hz	96Hz	
20	104Hz	104Hz	
21	110Hz	110Hz	
22	116Hz	116Hz	
23	124Hz	124Hz	
24	132Hz	132Hz	
25	52Hz	52Hz	ON
26	62Hz	62Hz	ON
27	68Hz	68Hz	ON
28	74Hz	74Hz	ON
29	80Hz	80Hz	ON
30	88Hz	88Hz	ON
31	96Hz	96Hz	ON
32	104Hz	104Hz	ON
33	116Hz	116Hz	ON
34	124Hz	124Hz	ON
35	132Hz	132Hz	ON
36	144Hz	144Hz	ON
37	158Hz	158Hz	ON
38	176Hz	176Hz	ON
39	188Hz	188Hz	ON
40	202Hz	202Hz	ON
41	210Hz	210Hz	ON

REYQ22PY1, 24PY1 (10/12+12HP)

(To increase Step No.)

STEP No.	unit 1 INV	unit 2 INV	STD
1	52Hz	52Hz	←Initial step
2	56Hz	56Hz	
3	62Hz	62Hz	
4	66Hz	66Hz	
5	70Hz	70Hz	
6	74Hz	74Hz	
7	80Hz	80Hz	
8	88Hz	88Hz	
9	92Hz	92Hz	
10	96Hz	96Hz	
11	104Hz	104Hz	
12	110Hz	110Hz	
13	116Hz	116Hz	
14	124Hz	124Hz	
15	132Hz	132Hz	
16	144Hz	144Hz	
17	158Hz	158Hz	
18	166Hz	166Hz	
19	176Hz	176Hz	
20	80Hz	80Hz	ON1
21	88Hz	88Hz	ON1
22	96Hz	96Hz	ON1
23	104Hz	104Hz	ON1
24	116Hz	116Hz	ON1
25	124Hz	124Hz	ON1
26	132Hz	132Hz	ON1
27	88Hz	88Hz	ON2
28	96Hz	96Hz	ON2
29	104Hz	104Hz	ON2
30	124Hz	124Hz	ON2
31	144Hz	144Hz	ON2
32	158Hz	158Hz	ON2
33	166Hz	176Hz	ON2
34	176Hz	158Hz	ON2
35	188Hz	188Hz	ON2
36	202Hz	202Hz	ON2
37	210Hz	210Hz	ON2
38	202Hz	202Hz	ON2
39	210Hz	210Hz	ON2

(To decrease Step No.)

STEP No.	unit 1 INV	unit 2 INV	STD
1	52Hz		
2	56Hz		
3	62Hz		
4	68Hz		
5	74Hz		
6	80Hz		
7	88Hz		
8	96Hz		
9	104Hz		
10	52Hz	52Hz	
11	56Hz	56Hz	
12	62Hz	62Hz	
13	66Hz	66Hz	
14	70Hz	70Hz	
15	74Hz	74Hz	
16	80Hz	80Hz	
17	88Hz	88Hz	
18	92Hz	92Hz	
19	96Hz	96Hz	
20	104Hz	104Hz	
21	110Hz	110Hz	
22	116Hz	116Hz	
23	124Hz	124Hz	
24	132Hz	132Hz	
25	52Hz	52Hz	ON1
26	62Hz	62Hz	ON1
27	68Hz	68Hz	ON1
28	74Hz	74Hz	ON1
29	80Hz	80Hz	ON1
30	88Hz	88Hz	ON1
31	96Hz	96Hz	ON1
32	104Hz	104Hz	ON1
33	52Hz	52Hz	ON2
34	62Hz	62Hz	ON2
35	74Hz	74Hz	ON2
36	88Hz	88Hz	ON2
37	96Hz	96Hz	ON2
38	104Hz	104Hz	ON2
39	124Hz	124Hz	ON2
40	144Hz	144Hz	ON2
41	158Hz	158Hz	ON2
42	166Hz	166Hz	ON2
43	176Hz	176Hz	ON2
44	188Hz	188Hz	ON2
45	202Hz	202Hz	ON2
46	210Hz	210Hz	ON2
47	202Hz	202Hz	ON2
48	210Hz	210Hz	ON2

Notes:

1. INV : Inverter compressor
 STD : Standard compressor
 Figures after ON represent the number of STD compressors in operation.
2. "Master unit", and "slave unit" in this section are the names for control, and they will be transferred according to the priority of rotation system.
3. Depending on the operating conditions of compressors, the compressors may run in patterns other than those aforementioned.

Three-unit multi system

REYQ26PY1, 28PY1 (10/12+16HP)

REYQ 32PY1 (16+16HP)

(To increase Step No.)

(To decrease Step No.)

(To increase Step No.)

(To decrease Step No.)

STEP No.	unit 1 INV	unit 2 INV	STD
1	52Hz	52Hz	◀ Initial step
2	56Hz	56Hz	
3	62Hz	62Hz	
4	66Hz	66Hz	
5	70Hz	70Hz	
6	74Hz	74Hz	
7	80Hz	80Hz	
8	88Hz	88Hz	
9	92Hz	92Hz	
10	96Hz	96Hz	
11	104Hz	104Hz	
12	110Hz	110Hz	
13	116Hz	116Hz	
14	124Hz	124Hz	
15	132Hz	132Hz	
16	144Hz	144Hz	
17	158Hz	158Hz	
18	166Hz	166Hz	
19	176Hz	176Hz	
20	80Hz	80Hz	ON1
21	88Hz	88Hz	ON1
22	96Hz	96Hz	ON1
23	104Hz	104Hz	ON1
24	116Hz	116Hz	ON1
25	124Hz	124Hz	ON1
26	132Hz	132Hz	ON1
27	88Hz	88Hz	ON2
28	96Hz	96Hz	ON2
29	104Hz	104Hz	ON2
30	124Hz	124Hz	ON2
31	144Hz	144Hz	ON2
32	92Hz	92Hz	ON3
33	104Hz	104Hz	ON3
34	116Hz	116Hz	ON3
35	124Hz	124Hz	ON3
36	144Hz	144Hz	ON3
37	158Hz	158Hz	ON3
38	166Hz	166Hz	ON3
39	176Hz	176Hz	ON3
40	188Hz	188Hz	ON3
41	202Hz	202Hz	ON3
42	210Hz	210Hz	ON3

STEP No.	unit 1 INV	unit 2 INV	STD
1	52Hz		
2	56Hz		
3	62Hz		
4	66Hz		
5	74Hz		
6	80Hz		
7	88Hz		
8	96Hz		
9	104Hz		
10	52Hz	52Hz	
11	56Hz	56Hz	
12	62Hz	62Hz	
13	66Hz	66Hz	
14	70Hz	70Hz	
15	74Hz	74Hz	
16	80Hz	80Hz	
17	88Hz	88Hz	
18	92Hz	92Hz	
19	96Hz	96Hz	
20	104Hz	104Hz	
21	110Hz	110Hz	
22	116Hz	116Hz	
23	124Hz	124Hz	
24	132Hz	132Hz	
25	52Hz	52Hz	ON1
26	62Hz	62Hz	ON1
27	68Hz	68Hz	ON1
28	74Hz	74Hz	ON1
29	80Hz	80Hz	ON1
30	88Hz	88Hz	ON1
31	96Hz	96Hz	ON1
32	104Hz	104Hz	ON1
33	52Hz	52Hz	ON2
34	62Hz	62Hz	ON2
35	74Hz	74Hz	ON2
36	88Hz	88Hz	ON2
37	96Hz	96Hz	ON2
38	52Hz	52Hz	ON3
39	62Hz	62Hz	ON3
40	74Hz	74Hz	ON3
41	92Hz	92Hz	ON3
42	104Hz	104Hz	ON3
43	116Hz	116Hz	ON3
44	124Hz	124Hz	ON3
45	144Hz	144Hz	ON3
46	158Hz	158Hz	ON3
47	166Hz	166Hz	ON3
48	176Hz	176Hz	ON3
49	188Hz	188Hz	ON3
50	202Hz	202Hz	ON3
51	210Hz	210Hz	ON3

STEP No.	unit 1 INV	unit 2 INV	STD
1	52Hz	52Hz	◀ Initial step
2	56Hz	56Hz	
3	62Hz	62Hz	
4	66Hz	66Hz	
5	70Hz	70Hz	
6	74Hz	74Hz	
7	80Hz	80Hz	
8	88Hz	88Hz	
9	92Hz	92Hz	
10	96Hz	96Hz	
11	104Hz	104Hz	
12	110Hz	110Hz	
13	116Hz	116Hz	
14	124Hz	124Hz	
15	132Hz	132Hz	
16	144Hz	144Hz	
17	158Hz	158Hz	
18	166Hz	166Hz	
19	176Hz	176Hz	
20	80Hz	80Hz	ON1
21	88Hz	88Hz	ON1
22	96Hz	96Hz	ON1
23	104Hz	104Hz	ON1
24	116Hz	116Hz	ON1
25	124Hz	124Hz	ON1
26	132Hz	132Hz	ON1
27	88Hz	88Hz	ON2
28	96Hz	96Hz	ON2
29	104Hz	104Hz	ON2
30	124Hz	124Hz	ON2
31	144Hz	144Hz	ON2
32	92Hz	92Hz	ON3
33	104Hz	104Hz	ON3
34	116Hz	116Hz	ON3
35	124Hz	124Hz	ON3
36	144Hz	144Hz	ON3
37	96Hz	96Hz	ON4
38	104Hz	104Hz	ON4
39	116Hz	116Hz	ON4
40	124Hz	124Hz	ON4
41	144Hz	144Hz	ON4
42	158Hz	158Hz	ON4
43	166Hz	166Hz	ON4
44	176Hz	176Hz	ON4
45	188Hz	188Hz	ON4
46	202Hz	202Hz	ON4
47	210Hz	210Hz	ON4

STEP No.	unit 1 INV	unit 2 INV	STD
1	52Hz		
2	56Hz		
3	62Hz		
4	66Hz		
5	74Hz		
6	80Hz		
7	88Hz		
8	96Hz		
9	104Hz		
10	52Hz	52Hz	
11	56Hz	56Hz	
12	62Hz	62Hz	
13	66Hz	66Hz	
14	70Hz	70Hz	
15	74Hz	74Hz	
16	80Hz	80Hz	
17	88Hz	88Hz	
18	92Hz	92Hz	
19	96Hz	96Hz	
20	104Hz	104Hz	
21	110Hz	110Hz	
22	116Hz	116Hz	
23	124Hz	124Hz	
24	132Hz	132Hz	
25	52Hz	52Hz	ON1
26	62Hz	62Hz	ON1
27	68Hz	68Hz	ON1
28	74Hz	74Hz	ON1
29	80Hz	80Hz	ON1
30	88Hz	88Hz	ON1
31	96Hz	96Hz	ON1
32	104Hz	104Hz	ON1
33	52Hz	52Hz	ON2
34	62Hz	62Hz	ON2
35	74Hz	74Hz	ON2
36	88Hz	88Hz	ON2
37	96Hz	96Hz	ON2
38	52Hz	52Hz	ON3
39	62Hz	62Hz	ON3
40	74Hz	74Hz	ON3
41	96Hz	96Hz	ON3
42	104Hz	104Hz	ON3
43	52Hz	52Hz	ON4
44	62Hz	62Hz	ON4
45	74Hz	74Hz	ON4
46	96Hz	96Hz	ON4
47	104Hz	104Hz	ON4
48	116Hz	116Hz	ON4
49	124Hz	124Hz	ON4
50	144Hz	144Hz	ON4
51	158Hz	158Hz	ON4
52	166Hz	166Hz	ON4
53	176Hz	176Hz	ON4
54	188Hz	188Hz	ON4
55	202Hz	202Hz	ON4
56	210Hz	210Hz	ON4

Notes:

- INV : Inverter compressor
STD : Standard compressor
Figures after ON represent the number of STD compressors in operation.
- “Master unit”, and “slave unit” in this section are the names for control, and they will be transferred according to the priority of rotation system.
- Depending on the operating conditions of compressors, the compressors may run in patterns other than those aforementioned.

REYQ34PY1, 36PY1 (8+10/12+16HP)

REYQ38PY1, 40PY1 (10/12+12+16HP)

(To increase Step No.)

STEP No.	unit 1 INV	unit 2 INV	unit 3 INV	STD
1	52Hz	52Hz	52Hz	◀Initial step
2	56Hz	56Hz	56Hz	
3	62Hz	62Hz	62Hz	
4	66Hz	66Hz	66Hz	
5	68Hz	68Hz	68Hz	
6	70Hz	70Hz	70Hz	
7	74Hz	74Hz	74Hz	
8	80Hz	80Hz	80Hz	
9	88Hz	88Hz	88Hz	
10	96Hz	96Hz	96Hz	
11	104Hz	104Hz	104Hz	
12	110Hz	110Hz	110Hz	
13	116Hz	116Hz	116Hz	
14	124Hz	124Hz	124Hz	
15	80Hz	80Hz	80Hz	ON1
16	88Hz	88Hz	88Hz	ON1
17	96Hz	96Hz	96Hz	ON1
18	104Hz	104Hz	104Hz	ON1
19	116Hz	116Hz	116Hz	ON1
20	124Hz	124Hz	124Hz	ON1
21	132Hz	132Hz	132Hz	ON1
22	88Hz	88Hz	88Hz	ON2
23	96Hz	96Hz	96Hz	ON2
24	104Hz	104Hz	104Hz	ON2
25	124Hz	124Hz	124Hz	ON2
26	144Hz	144Hz	144Hz	ON2
27	92Hz	92Hz	92Hz	ON3
28	104Hz	104Hz	104Hz	ON3
29	116Hz	116Hz	116Hz	ON3
30	124Hz	124Hz	124Hz	ON3
31	144Hz	144Hz	144Hz	ON3
32	158Hz	158Hz	158Hz	ON3
33	166Hz	166Hz	166Hz	ON3
34	176Hz	176Hz	176Hz	ON3
35	188Hz	188Hz	188Hz	ON3
36	202Hz	202Hz	202Hz	ON3
37	210Hz	210Hz	210Hz	ON3

(To decrease Step No.)

STEP No.	unit 1 INV	unit 2 INV	unit 3 INV	STD
1	52Hz			
2	56Hz			
3	62Hz			
4	68Hz			
5	74Hz			
6	80Hz			
7	88Hz			
8	96Hz			
9	104Hz			
10	52Hz	52Hz		
11	56Hz	56Hz		
12	62Hz	62Hz		
13	66Hz	66Hz		
14	70Hz	70Hz		
15	74Hz	74Hz		
16	52Hz	52Hz	52Hz	
17	56Hz	56Hz	56Hz	
18	62Hz	62Hz	62Hz	
19	66Hz	66Hz	66Hz	
20	68Hz	68Hz	68Hz	
21	70Hz	70Hz	70Hz	
22	74Hz	74Hz	74Hz	
23	80Hz	80Hz	80Hz	
24	88Hz	88Hz	88Hz	
25	96Hz	96Hz	96Hz	
26	52Hz	52Hz	52Hz	ON1
27	62Hz	62Hz	62Hz	ON1
28	68Hz	68Hz	68Hz	ON1
29	74Hz	74Hz	74Hz	ON1
30	80Hz	80Hz	80Hz	ON1
31	88Hz	88Hz	88Hz	ON1
32	96Hz	96Hz	96Hz	ON1
33	104Hz	104Hz	104Hz	ON1
34	52Hz	52Hz	52Hz	ON2
35	62Hz	62Hz	62Hz	ON2
36	74Hz	74Hz	74Hz	ON2
37	88Hz	88Hz	88Hz	ON2
38	96Hz	96Hz	96Hz	ON2
39	52Hz	52Hz	52Hz	ON3
40	62Hz	62Hz	62Hz	ON3
41	74Hz	74Hz	74Hz	ON3
42	92Hz	92Hz	92Hz	ON3
43	104Hz	104Hz	104Hz	ON3
44	116Hz	116Hz	116Hz	ON3
45	124Hz	124Hz	124Hz	ON3
46	144Hz	144Hz	144Hz	ON3
47	158Hz	158Hz	158Hz	ON3
48	166Hz	166Hz	166Hz	ON3
49	176Hz	176Hz	176Hz	ON3
50	188Hz	188Hz	188Hz	ON3
51	202Hz	202Hz	202Hz	ON3
52	210Hz	210Hz	210Hz	ON3

(To increase Step No.)

STEP No.	unit 1 INV	unit 2 INV	unit 3 INV	STD
1	52Hz	52Hz	52Hz	◀Initial step
2	56Hz	56Hz	56Hz	
3	62Hz	62Hz	62Hz	
4	66Hz	66Hz	66Hz	
5	68Hz	68Hz	68Hz	
6	70Hz	70Hz	70Hz	
7	74Hz	74Hz	74Hz	
8	80Hz	80Hz	80Hz	
9	88Hz	88Hz	88Hz	
10	96Hz	96Hz	96Hz	
11	104Hz	104Hz	104Hz	
12	110Hz	110Hz	110Hz	
13	116Hz	116Hz	116Hz	
14	124Hz	124Hz	124Hz	
15	80Hz	80Hz	80Hz	ON1
16	88Hz	88Hz	88Hz	ON1
17	96Hz	96Hz	96Hz	ON1
18	104Hz	104Hz	104Hz	ON1
19	116Hz	116Hz	116Hz	ON1
20	124Hz	124Hz	124Hz	ON1
21	132Hz	132Hz	132Hz	ON1
22	88Hz	88Hz	88Hz	ON2
23	96Hz	96Hz	96Hz	ON2
24	104Hz	104Hz	104Hz	ON2
25	124Hz	124Hz	124Hz	ON2
26	144Hz	144Hz	144Hz	ON2
27	92Hz	92Hz	92Hz	ON3
28	104Hz	104Hz	104Hz	ON3
29	116Hz	116Hz	116Hz	ON3
30	124Hz	124Hz	124Hz	ON3
31	144Hz	144Hz	144Hz	ON3
32	96Hz	96Hz	96Hz	ON4
33	104Hz	104Hz	104Hz	ON4
34	116Hz	116Hz	116Hz	ON4
35	124Hz	124Hz	124Hz	ON4
36	144Hz	144Hz	144Hz	ON4
37	158Hz	158Hz	158Hz	ON4
38	166Hz	166Hz	166Hz	ON4
39	176Hz	176Hz	176Hz	ON4
40	188Hz	188Hz	188Hz	ON4
41	202Hz	202Hz	202Hz	ON4
42	210Hz	210Hz	210Hz	ON4

(To decrease Step No.)

STEP No.	unit 1 INV	unit 2 INV	unit 3 INV	STD
1	52Hz			
2	56Hz			
3	62Hz			
4	68Hz			
5	74Hz			
6	80Hz			
7	88Hz			
8	96Hz			
9	104Hz			
10	52Hz	52Hz		
11	56Hz	56Hz		
12	62Hz	62Hz		
13	66Hz	66Hz		
14	70Hz	70Hz		
15	74Hz	74Hz		
16	52Hz	52Hz	52Hz	
17	56Hz	56Hz	56Hz	
18	62Hz	62Hz	62Hz	
19	66Hz	66Hz	66Hz	
20	68Hz	68Hz	68Hz	
21	70Hz	70Hz	70Hz	
22	74Hz	74Hz	74Hz	
23	80Hz	80Hz	80Hz	
24	88Hz	88Hz	88Hz	
25	96Hz	96Hz	96Hz	
26	52Hz	52Hz	52Hz	ON1
27	62Hz	62Hz	62Hz	ON1
28	68Hz	68Hz	68Hz	ON1
29	74Hz	74Hz	74Hz	ON1
30	80Hz	80Hz	80Hz	ON1
31	88Hz	88Hz	88Hz	ON1
32	96Hz	96Hz	96Hz	ON1
33	104Hz	104Hz	104Hz	ON1
34	52Hz	52Hz	52Hz	ON2
35	62Hz	62Hz	62Hz	ON2
36	74Hz	74Hz	74Hz	ON2
37	88Hz	88Hz	88Hz	ON2
38	96Hz	96Hz	96Hz	ON2
39	52Hz	52Hz	52Hz	ON3
40	62Hz	62Hz	62Hz	ON3
41	74Hz	74Hz	74Hz	ON3
42	92Hz	92Hz	92Hz	ON3
43	104Hz	104Hz	104Hz	ON3
44	52Hz	52Hz	52Hz	ON4
45	62Hz	62Hz	62Hz	ON4
46	74Hz	74Hz	74Hz	ON4
47	96Hz	96Hz	96Hz	ON4
48	104Hz	104Hz	104Hz	ON4
49	116Hz	116Hz	116Hz	ON4
50	124Hz	124Hz	124Hz	ON4
51	144Hz	144Hz	144Hz	ON4
52	158Hz	158Hz	158Hz	ON4
53	166Hz	166Hz	166Hz	ON4
54	176Hz	176Hz	176Hz	ON4
55	188Hz	188Hz	188Hz	ON4
56	202Hz	202Hz	202Hz	ON4
57	210Hz	210Hz	210Hz	ON4

Notes:

- INV : Inverter compressor
STD : Standard compressor
Figures after ON represent the number of STD compressors in operation.
- "Master unit", and "slave unit" in this section are the names for control, and they will be transferred according to the priority of rotation system.
- Depending on the operating conditions of compressors, the compressors may run in patterns other than those aforementioned.

REYQ42PY1, 44PY1 (10/12+16+16HP)

REYQ46PY1, 48PY1 (14/16+16+16HP)

(To increase Step No.)					(To decrease Step No.)				
STEP No.	unit 1 INV	unit 2 INV	unit 3 INV	STD	STEP No.	unit 1 INV	unit 2 INV	unit 3 INV	STD
1	52Hz	52Hz	52Hz	◀Initial step	1	52Hz			
2	56Hz	56Hz	56Hz		2	56Hz			
3	62Hz	62Hz	62Hz		3	62Hz			
4	66Hz	66Hz	66Hz		4	68Hz			
5	68Hz	68Hz	68Hz		5	74Hz			
6	70Hz	70Hz	70Hz		6	80Hz			
7	74Hz	74Hz	74Hz		7	88Hz			
8	80Hz	80Hz	80Hz		8	96Hz			
9	88Hz	88Hz	88Hz		9	104Hz			
10	96Hz	96Hz	96Hz		10	52Hz	52Hz		
11	104Hz	104Hz	104Hz		11	56Hz	56Hz		
12	110Hz	110Hz	110Hz		12	62Hz	62Hz		
13	116Hz	116Hz	116Hz		13	66Hz	66Hz		
14	124Hz	124Hz	124Hz		14	70Hz	70Hz		
15	80Hz	80Hz	80Hz	ON1	15	74Hz	74Hz		
16	88Hz	88Hz	88Hz	ON1	16	52Hz	52Hz	52Hz	
17	96Hz	96Hz	96Hz	ON1	17	56Hz	56Hz	56Hz	
18	104Hz	104Hz	104Hz	ON1	18	62Hz	62Hz	62Hz	
19	116Hz	116Hz	116Hz	ON1	19	66Hz	66Hz	66Hz	
20	124Hz	124Hz	124Hz	ON1	20	68Hz	68Hz	68Hz	
21	132Hz	132Hz	132Hz	ON1	21	70Hz	70Hz	70Hz	
22	88Hz	88Hz	88Hz	ON2	22	74Hz	74Hz	74Hz	
23	96Hz	96Hz	96Hz	ON2	23	80Hz	80Hz	80Hz	
24	104Hz	104Hz	104Hz	ON2	24	88Hz	88Hz	88Hz	
25	124Hz	124Hz	124Hz	ON2	25	96Hz	96Hz	96Hz	
26	144Hz	144Hz	144Hz	ON2	26	52Hz	52Hz	52Hz	ON1
27	92Hz	92Hz	92Hz	ON3	27	62Hz	62Hz	62Hz	ON1
28	104Hz	104Hz	104Hz	ON3	28	68Hz	68Hz	68Hz	ON1
29	116Hz	116Hz	116Hz	ON3	29	74Hz	74Hz	74Hz	ON1
30	124Hz	124Hz	124Hz	ON3	30	80Hz	80Hz	80Hz	ON1
31	144Hz	144Hz	144Hz	ON3	31	88Hz	88Hz	88Hz	ON1
32	96Hz	96Hz	96Hz	ON4	32	96Hz	96Hz	96Hz	ON1
33	104Hz	104Hz	104Hz	ON4	33	104Hz	104Hz	104Hz	ON1
34	116Hz	116Hz	116Hz	ON4	34	52Hz	52Hz	52Hz	ON2
35	124Hz	124Hz	124Hz	ON4	35	62Hz	62Hz	62Hz	ON2
36	144Hz	144Hz	144Hz	ON4	36	74Hz	74Hz	74Hz	ON2
37	96Hz	96Hz	96Hz	ON5	37	88Hz	88Hz	88Hz	ON2
38	104Hz	104Hz	104Hz	ON5	38	96Hz	96Hz	96Hz	ON2
39	116Hz	116Hz	116Hz	ON5	39	52Hz	52Hz	52Hz	ON3
40	124Hz	124Hz	124Hz	ON5	40	62Hz	62Hz	62Hz	ON3
41	144Hz	144Hz	144Hz	ON5	41	74Hz	74Hz	74Hz	ON3
42	158Hz	158Hz	158Hz	ON5	42	92Hz	92Hz	92Hz	ON3
43	166Hz	166Hz	166Hz	ON5	43	104Hz	104Hz	104Hz	ON3
44	176Hz	176Hz	176Hz	ON5	44	52Hz	52Hz	52Hz	ON4
45	188Hz	188Hz	188Hz	ON5	45	62Hz	62Hz	62Hz	ON4
46	202Hz	202Hz	202Hz	ON5	46	74Hz	74Hz	74Hz	ON4
47	210Hz	210Hz	210Hz	ON5	47	96Hz	96Hz	96Hz	ON4
					48	52Hz	52Hz	52Hz	ON5
					49	68Hz	68Hz	68Hz	ON5
					50	80Hz	80Hz	80Hz	ON5
					51	96Hz	96Hz	96Hz	ON5
					52	104Hz	104Hz	104Hz	ON5
					53	116Hz	116Hz	116Hz	ON5
					54	124Hz	124Hz	124Hz	ON5
					55	144Hz	144Hz	144Hz	ON5
					56	158Hz	158Hz	158Hz	ON5
					57	166Hz	166Hz	166Hz	ON5
					58	176Hz	176Hz	176Hz	ON5
					59	188Hz	188Hz	188Hz	ON5
					60	202Hz	202Hz	202Hz	ON5
					61	210Hz	210Hz	210Hz	ON5

(To increase Step No.)					(To decrease Step No.)				
STEP No.	unit 1 INV	unit 2 INV	unit 3 INV	STD	STEP No.	unit 1 INV	unit 2 INV	unit 3 INV	STD
1	52Hz	52Hz	52Hz	◀Initial step	1	52Hz			
2	56Hz	56Hz	56Hz		2	56Hz			
3	62Hz	62Hz	62Hz		3	62Hz			
4	66Hz	66Hz	66Hz		4	68Hz			
5	68Hz	68Hz	68Hz		5	74Hz			
6	70Hz	70Hz	70Hz		6	80Hz			
7	74Hz	74Hz	74Hz		7	88Hz			
8	80Hz	80Hz	80Hz		8	96Hz			
9	88Hz	88Hz	88Hz		9	104Hz			
10	96Hz	96Hz	96Hz		10	52Hz	52Hz		
11	104Hz	104Hz	104Hz		11	56Hz	56Hz		
12	110Hz	110Hz	110Hz		12	62Hz	62Hz		
13	116Hz	116Hz	116Hz		13	66Hz	66Hz		
14	124Hz	124Hz	124Hz		14	70Hz	70Hz		
15	80Hz	80Hz	80Hz	ON1	15	74Hz	74Hz		
16	88Hz	88Hz	88Hz	ON1	16	52Hz	52Hz	52Hz	
17	96Hz	96Hz	96Hz	ON1	17	56Hz	56Hz	56Hz	
18	104Hz	104Hz	104Hz	ON1	18	62Hz	62Hz	62Hz	
19	116Hz	116Hz	116Hz	ON1	19	66Hz	66Hz	66Hz	
20	124Hz	124Hz	124Hz	ON1	20	68Hz	68Hz	68Hz	
21	132Hz	132Hz	132Hz	ON1	21	70Hz	70Hz	70Hz	
22	88Hz	88Hz	88Hz	ON2	22	74Hz	74Hz	74Hz	
23	96Hz	96Hz	96Hz	ON2	23	80Hz	80Hz	80Hz	
24	104Hz	104Hz	104Hz	ON2	24	88Hz	88Hz	88Hz	
25	124Hz	124Hz	124Hz	ON2	25	96Hz	96Hz	96Hz	
26	144Hz	144Hz	144Hz	ON2	26	52Hz	52Hz	52Hz	ON1
27	92Hz	92Hz	92Hz	ON3	27	62Hz	62Hz	62Hz	ON1
28	104Hz	104Hz	104Hz	ON3	28	68Hz	68Hz	68Hz	ON1
29	116Hz	116Hz	116Hz	ON3	29	74Hz	74Hz	74Hz	ON1
30	124Hz	124Hz	124Hz	ON3	30	80Hz	80Hz	80Hz	ON1
31	144Hz	144Hz	144Hz	ON3	31	88Hz	88Hz	88Hz	ON1
32	96Hz	96Hz	96Hz	ON4	32	96Hz	96Hz	96Hz	ON1
33	104Hz	104Hz	104Hz	ON4	33	104Hz	104Hz	104Hz	ON1
34	116Hz	116Hz	116Hz	ON4	34	52Hz	52Hz	52Hz	ON2
35	124Hz	124Hz	124Hz	ON4	35	62Hz	62Hz	62Hz	ON2
36	144Hz	144Hz	144Hz	ON4	36	74Hz	74Hz	74Hz	ON2
37	96Hz	96Hz	96Hz	ON5	37	88Hz	88Hz	88Hz	ON2
38	104Hz	104Hz	104Hz	ON5	38	96Hz	96Hz	96Hz	ON2
39	116Hz	116Hz	116Hz	ON5	39	52Hz	52Hz	52Hz	ON3
40	124Hz	124Hz	124Hz	ON5	40	62Hz	62Hz	62Hz	ON3
41	144Hz	144Hz	144Hz	ON5	41	74Hz	74Hz	74Hz	ON3
42	96Hz	96Hz	96Hz	ON6	42	92Hz	92Hz	92Hz	ON3
43	104Hz	104Hz	104Hz	ON6	43	104Hz	104Hz	104Hz	ON3
44	116Hz	116Hz	116Hz	ON6	44	52Hz	52Hz	52Hz	ON4
45	124Hz	124Hz	124Hz	ON6	45	62Hz	62Hz	62Hz	ON4
46	144Hz	144Hz	144Hz	ON6	46	74Hz	74Hz	74Hz	ON4
47	158Hz	158Hz	158Hz	ON6	47	96Hz	96Hz	96Hz	ON4
48	166Hz	166Hz	166Hz	ON6	48	104Hz	104Hz	104Hz	ON4
49	176Hz	176Hz	176Hz	ON6	49	52Hz	52Hz	52Hz	ON5
50	188Hz	188Hz	188Hz	ON6	50	68Hz	68Hz	68Hz	ON5
51	202Hz	202Hz	202Hz	ON6	51	80Hz	80Hz	80Hz	ON5
52	210Hz	210Hz	210Hz	ON6	52	96Hz	96Hz	96Hz	ON5
					53	104Hz	104Hz	104Hz	ON5
					54	52Hz	52Hz	52Hz	ON6
					55	68Hz	68Hz	68Hz	ON6
					56	80Hz	80Hz	80Hz	ON6
					57	96Hz	96Hz	96Hz	ON6
					58	104Hz	104Hz	104Hz	ON6
					59	116Hz	116Hz	116Hz	ON6
					60	124Hz	124Hz	124Hz	ON6
					61	144Hz	144Hz	144Hz	ON6
					62	158Hz	158Hz	158Hz	ON6
					63	166Hz	166Hz	166Hz	ON6
					64	176Hz	176Hz	176Hz	ON6
					65	188Hz	188Hz	188Hz	ON6
					66	202Hz	202Hz	202Hz	ON6
					67	210Hz	210Hz	210Hz	ON6

Notes:

- INV : Inverter compressor
STD : Standard compressor
Figures after ON represent the number of STD compressors in operation.
- "Master unit", and "slave unit" in this section are the names for control, and they will be transferred according to the priority of rotation system.
- Depending on the operating conditions of compressors, the compressors may run in patterns other than those aforementioned.

2.3 Electronic Expansion Valve PI Control

Main electronic expansion valve EVM control

When the outdoor unit heat exchanging is performed via the evaporator (20SA is set to ON), this function is used to exert PI control on the electronic expansion valve (Y1E or Y3E) so that the evaporator outlet superheated degree (SH) will become constant.

$$SH = T_g - T_e$$

SH: Evaporator outlet superheated degree (°C)

T_g : Suction pipe temperature (°C) detected by the heat exchanger gas pipe thermistor R2T.

T_e : Low pressure equivalent saturated temperature (°C)

Subcooling electronic expansion valve EVT control

In order to make the maximum use of the subcool heat exchanger, this function is used to exert PI control on the electronic expansion valve (Y2E, Y5E or Y3E) so that the evaporator-side gas pipe superheated degree (SH) will become constant.

$$SH = T_{sh} - T_e$$

SH: Evaporator outlet superheated degree (°C)

T_{sh}: Suction pipe temperature (°C) detected by the subcool heat exchanger outlet thermistor R5T

T_e: Low pressure equivalent saturated temperature (°C)

Refrigerant charge electronic expansion valve EVJ control

While in automatic refrigerant charge mode, this function is used to exert PI control on the opening degree of the electronic expansion valve (Y2E or Y4E) in response to outdoor temperature and close the valve after the completion of refrigerant charge.

For normal operation, fully open this electronic expansion valve.

2.4 Step Control of Outdoor Unit Fans

Used to control the revolutions of outdoor unit fans in the steps listed in table below, according to condition changes.

STEP No.	Fan revolutions (rpm)									
	Single type					Multiple type				
	8HP	10HP	12HP	14HP	16HP	M8	M10	M12	M14	M16
0	0	0	0	0	0	0	0	0	0/0	0/0
1	285/255	285/255	285/255	285/255	285/255	350	350	350	230/0	230/0
2	315/285	315/285	315/285	360/315	360/315	370	370	370	380/0	380/0
3	360/330	360/330	360/330	395/365	395/365	400	400	400	290/260	290/260
4	430/400	430/400	430/400	480/440	480/440	450	450	450	375/345	375/345
5	590/560	590/560	590/560	560/530	560/530	540	560	560	570/540	570/540
6	690/660	690/660	690/660	760/730	760/730	610	680	680	720/690	720/690
7	820/790	820/790	820/790	960/930	960/930	680	710	710	910/880	910/880
8	920/890	920/890	951/931	1125/1095	1155/1125	710	750	775	1091/1061	1091/1061
9	920/890	920/890	1020/990	1125/1095	1200/1170	796	821	870	1136/1106	1136/1106
	Fan1/Fan2	Fan1/Fan2	Fan1/Fan2	Fan1/Fan2	Fan1/Fan2				Fan1/Fan2	Fan1/Fan2

* Figures listed above are all those controlled while in standard mode, which vary when the system is set to high static pressure or capacity precedence mode.

2.5 Outdoor Unit Fan Control in Cooling Operation

While in cooling operation, if the outdoor temperature is low, this mode provides high-pressure control using the outdoor unit fan to retain appropriate liquid pressure, thus ensuring refrigerant circulation rate to be supplied to indoor units.

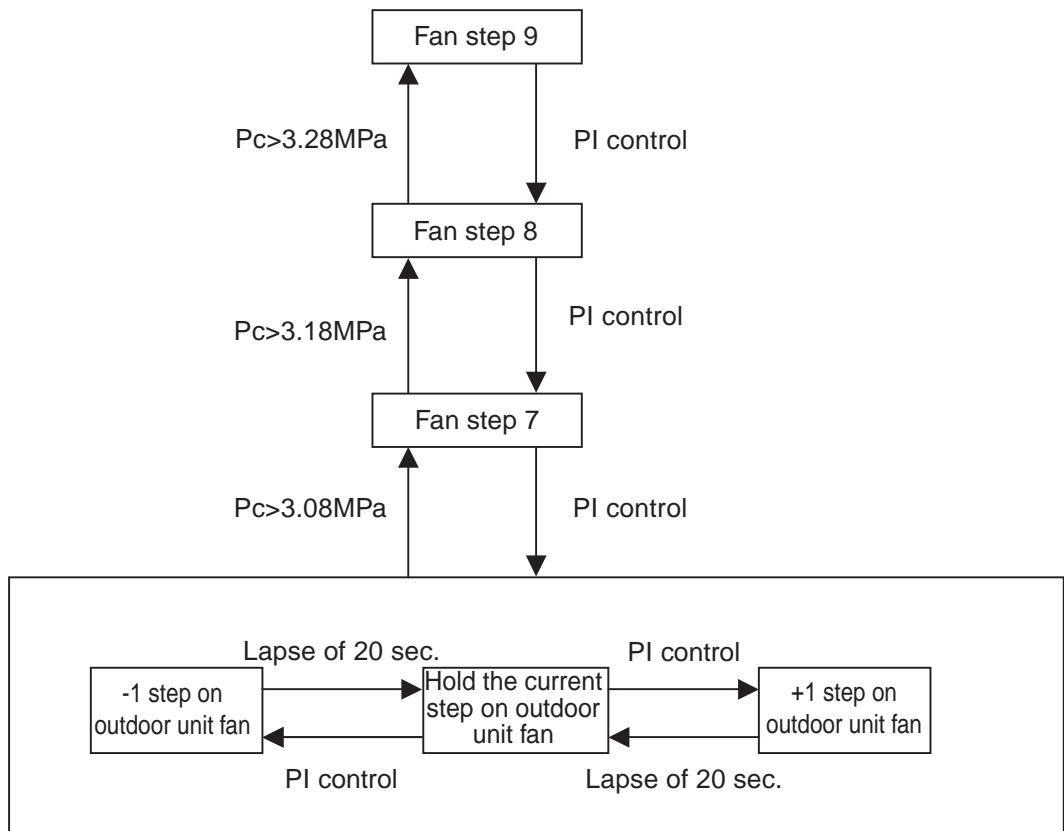

2.6 Heat Exchanger Control

While in heating or cool/heat simultaneous operation, ensure target condensing and evaporating temperature by changing over the air heat exchange of outdoor unit to the evaporator or the condenser in response to loads.

[Single system]

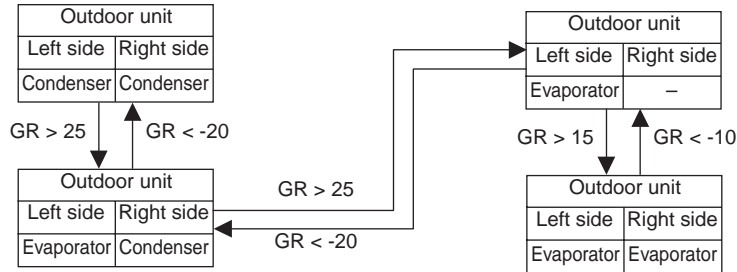

Note 1. "GR" is a numeric value representing the current balanced condition and calculated from target condensing temperature, target evaporating temperature, current condensing temperature, and current evaporating temperature.

[Multi outdoor unit system]

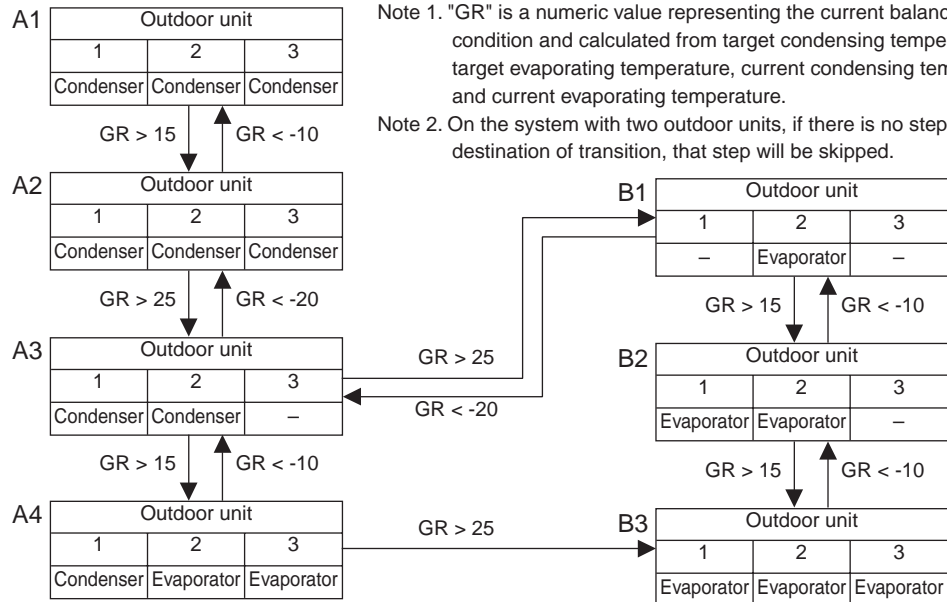

Note 1. "GR" is a numeric value representing the current balanced condition and calculated from target condensing temperature, target evaporating temperature, current condensing temperature, and current evaporating temperature.

Note 2. On the system with two outdoor units, if there is no step for the destination of transition, that step will be skipped.

3. Special Control

3.1 Startup Control

This control is used to equalize the pressure in the front and back of the compressor prior to the startup of the compressor, thus reducing startup loads. Furthermore, the inverter is turned ON to charge the capacitor.

In addition, to avoid stresses to the compressor due to oil return or else after the startup, the following control is made and the position of the four way valve is also determined. To position the four way valve, the master and slave units simultaneously start up.

3.1.1 Startup Control in Cooling Operation

Actuator	Symbol	Elect. symbol		Control before startup	Startup control	
		REYQ	REMQ		STEP1	STEP2
Compressor 1	—	M1C	M1C	0 Hz	52 Hz+OFF+OFF	52Hz+OFF+OFF+2STEP / 20 sec. (Until it reaches Pc-Pe>0.39 MPa)
Compressor 2		M2C	M2C			
Compressor 3		—	M3C			
Outdoor unit fan 1	—	M1F	M1F	STEP4	Ta<20°C: OFF Ta≥20°C: STEP4	+1step/15 sec. (When Pc_max>2.16 MPa) -1step/15 sec. (When Pc_max<1.77 MPa)
Outdoor unit fan 2		M2F	M2F			
Electronic expansion valve (Main)	EVM	Y1E Y3E	Y1E	0 pls	1375 pls	1375 pls
Electronic expansion valve (Supercooling)	EVT	Y2E Y5E	Y3E	0 pls	0 pls	0 pls
Electronic expansion valve (Refrigerant charge)	EVJ	Y4E	Y2E	80 pls	80 pls	80 pls
Four way valve (Heat exchanger switch)	20SA	Y2S Y9S	Y3S	OFF	OFF	OFF
Four way valve (High/low pressure gas pipe switch)	20SB	Y8S	Y2S	ON	ON	ON
Solenoid valve (Main bypass)	SVE	Y5S Y10S	Y6S	OFF	ON	ON
Solenoid valve (Hot gas)	SVP	Y4S	Y5S	OFF	OFF	OFF
Solenoid valve (Refrigerant regulator liquid pipe)	SVL	Y3S	Y4S	OFF	OFF	OFF
Solenoid valve (Refrigerant regulator gas vent pipe)	SVG	Y1S	Y1S	OFF	OFF	OFF
Solenoid valve (Refrigerant regulator exhaust pipe)	SVO	Y7S	Y7S	OFF	OFF	OFF
Solenoid valve (Refrigerant regulator discharge pipe)	SVT	Y6S	Y8S	OFF	OFF	OFF
Ending conditions				A lapse of 60 sec.	A lapse of 15 sec.	OR { <ul style="list-style-type: none"> • A lapse of 90 sec. • Pc - Pe>0.39 MPa

3.1.2 Startup Control in Heating Operation

Actuator	Symbol	Elect. symbol		Control before startup	Startup control	
		REYQ	REMQ		STEP1	STEP2
Compressor 1	—	M1C	M1C	0 Hz	52 Hz+OFF+OFF	52Hz+OFF+OFF+2STEP / 20 sec. (Until it reaches Pc-Pe>0.39 MPa)
Compressor 2		M2C	M2C			
Compressor 3		—	M3C			
Outdoor unit fan 1	—	M1F	M1F	STEP4	20SA=ON: STEP7 20SA=OFF +1step/15 sec. (When Pc_max>2.16 MPa) -1step/15 sec. (When Pc_max<1.77 MPa)	20SA=ON: STEP7 20SA=OFF +1step/15 sec. (When Pc_max>2.16 MPa) -1step/15 sec. (When Pc_max<1.77 MPa)
Outdoor unit fan 2		M2F	M2F			
Electronic expansion valve (Main)	EVM	Y1E Y3E	Y1E	0 pls	20SA=ON: SH Control 20SA=OFF: 1375 pls	20SA=ON: SH Control 20SA=OFF: 1375 pls
Electronic expansion valve (Supercooling)	EVT	Y2E Y5E	Y3E	0 pls	0 pls	0 pls
Electronic expansion valve (Refrigerant charge)	EVJ	Y4E	Y2E	80 pls	80 pls	80 pls
Four way valve (Heat exchanger switch)	20SA	Y2S Y9S	Y3S	When outdoor heat exchanger is evaporator: ON When outdoor heat exchanger is condenser: OFF	When outdoor heat exchanger is evaporator: ON When outdoor heat exchanger is condenser: OFF	When outdoor heat exchanger is evaporator: ON When outdoor heat exchanger is condenser: OFF
Four way valve (High/low pressure gas pipe switch)	20SB	Y8S	Y2S	OFF	OFF	OFF
Solenoid valve (Main bypass)	SVE	Y5S Y10S	Y6S	OFF	OFF	OFF
Solenoid valve (Hot gas)	SVP	Y4S	Y5S	OFF	OFF	OFF
Solenoid valve (Refrigerant regulator liquid pipe)	SVL	Y3S	Y4S	OFF	OFF	OFF
Solenoid valve (Refrigerant regulator gas vent pipe)	SVG	Y1S	Y1S	OFF	OFF	OFF
Solenoid valve (Refrigerant regulator exhaust pipe)	SVO	Y7S	Y7S	OFF	OFF	OFF
Solenoid valve (Refrigerant regulator discharge pipe)	SVT	Y6S	Y8S	OFF	OFF	OFF
Ending conditions				A lapse of 60 sec.	A lapse of 15 sec.	OR { • A lapse of 90 sec. • Pc - Pe>0.39 MPa

3.2 Large Capacity Start Up Control (Heating)

For startup, oil return operation, or setup after defrosting, start up multiple compressors at a high speed according to the conditions of indoor units with thermostat ON, thus maximizing the equipment capacity.

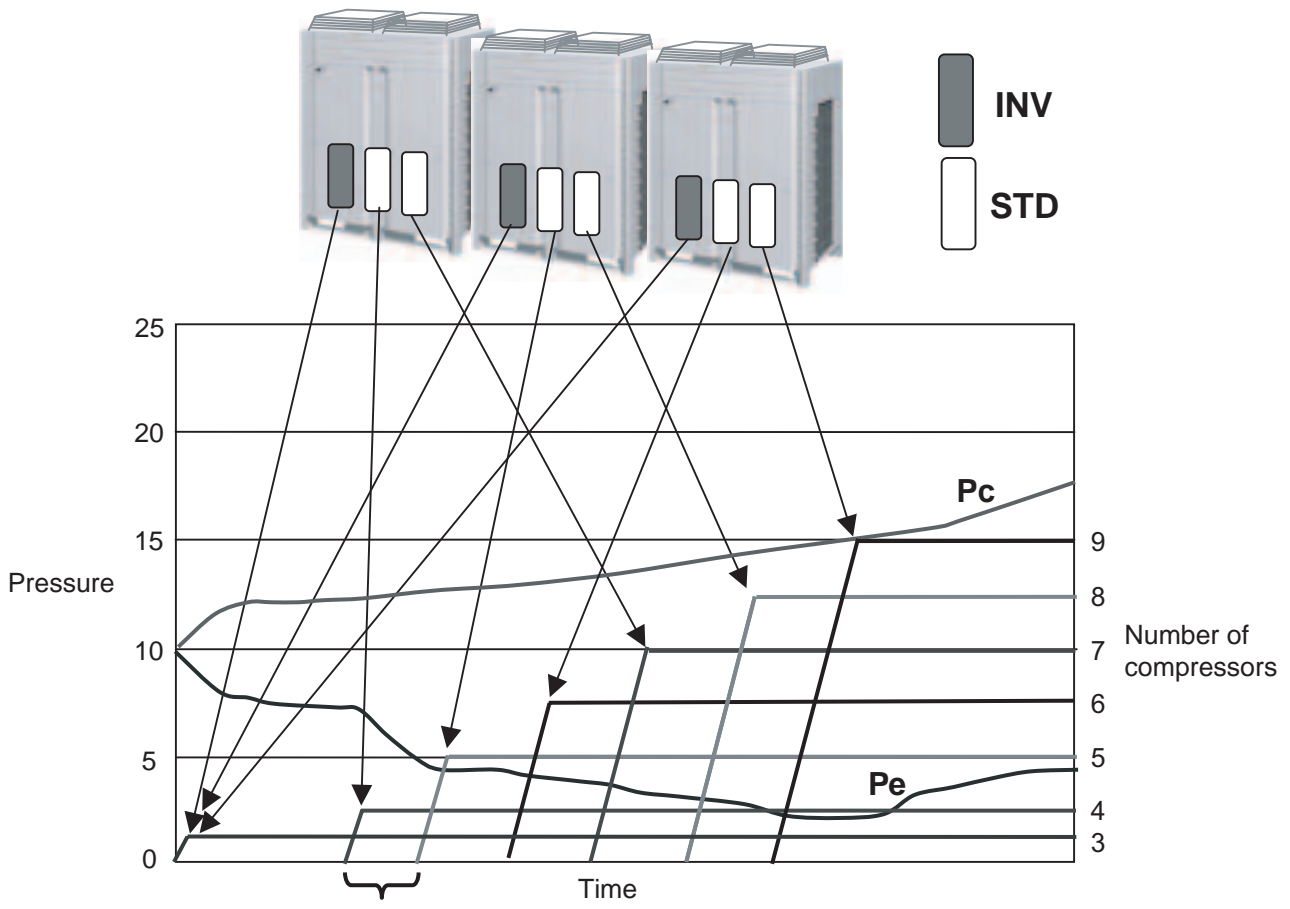

Start up STD compressors at intervals of 15 seconds.

[Starting conditions]

- OR
- The system starts heating operation with thermostat ON at a high load.
 - The system completes defrosting operation.
 - The system switches the operation mode from cooling to heating or simultaneous cooling and heating operation.

[Control]

1. Start multiple INV compressors in the system at one time.
2. Start multiple STD compressors in the system at intervals of 15 seconds.

3.3 Oil Return Operation

This function is used to recover refrigerant oil that flows out from the compressor to the system side by conducting oil return operation in order to prevent the compressor from running out of refrigerant oil.

3.3.1 Cooling Oil Return Operation

[Start conditions]

Referring to the following conditions, start cooling oil return operation.

- OR
- Integral oil rise rate is reached to specified level.
 - When cumulative compressor operating time exceeds 8 hours (2 hours when the power supply turns ON for the first time)

Furthermore, the integral oil rise rate is calculated by Tc, Te, and compressor loads.

The higher the compressor operating step No., the cumulative refrigerant oil consumption increases.

Outdoor unit actuator	Symbol	Elect. symbol		Oil return operation	Operation after oil return		
		REYQ	REMQ				
Compressor 1	—	M1C	M1C	52Hz+ON+ON (Subsequently, constant low pressure control) Maintain the number of compressors that were used before oil return operation)	52Hz+ON+ON (Subsequently, constant low pressure control) Maintain the number of compressors that were used before oil return operation)		
Compressor 2		M2C	M2C				
Compressor 3		—	M3C				
Outdoor unit fan 1	—	M1F	M1F	Cooling fan control	Cooling fan control		
Outdoor unit fan 2		M2F	M2F				
Four way valve (for heat exchanger selection)	20SA	Y2S Y9S	Y3S	OFF	OFF		
Four way valve (for high- and low-pressure gas pipe selection)	20SB	Y8S	Y2S	ON	ON		
Electronic expansion valve (main)	EVM	Y1E Y3E	Y1E	1375pls	1375pls		
Electronic expansion valve (subcooling)	EVT	Y2E Y5E	Y3E	SH control	SH control		
Electronic expansion valve (refilling refrigerant)	EVJ	Y4E	Y2E	80pls	80pls		
Solenoid valve (main bypass)	SVE	Y5S Y10S	Y6S	ON	ON		
Solenoid valve (hot gas)	SVP	Y4S	Y5S	OFF	OFF		
Solenoid valve (liquid pipe of refrigerant regulator)	SVL	Y3S	Y4S	0pls	0pls		
Solenoid valve (gas discharge pipe of refrigerant regulator)	SVG	Y1S	Y1S	0pls	0pls		
Solenoid valve (drain pipe of refrigerant regulator)	SVO	Y7S	Y7S	0pls	0pls		
Solenoid valve (discharge pipe of refrigerant regulator)	SVT	Y6S	Y8S	0pls	0pls		
End conditions				or	<ul style="list-style-type: none"> • After a lapse of 5 min. • TsA - Te<5°C 	or	<ul style="list-style-type: none"> • After a lapse of 3 min. • Pe_min<5°C • Pc_max>3.63MPa • HTdmax>100°C

*1: In case of multi outdoor unit system:

Master unit: It conducts the operation listed in the table above.

Slave units: Operating units conduct the operation listed in the table above.

Non-operating units conduct the operation listed in the table above after the "Oil returning" process.
(Non-operating units stop while in "Preparation" mode.)

Cooling indoor unit actuator		Oil return operation
Fan	Thermo ON unit	Remote control setting
	Unit not in operation	OFF
	Thermo OFF unit	Remote control setting
Motorized valve	Thermo ON unit	Normal opening degree
	Unit not in operation	192pls
	Thermo OFF unit	Normal opening degree for forced thermostat ON

Cooling BS unit actuator	Elect. symbol	Oil return operation
Electronic expansion vale (EVH)	Y4E	600pls
Electronic expansion vale (EVL)	Y5E	760pls
Electronic expansion vale (EVHS)	Y2E	480pls
Electronic expansion vale (EVLS)	Y3E	480pls
Electronic expansion vale (EVSC)	Y1E	0pls

3.3.2 Heating Oil Return Operation (including cooling / heating simultaneous operation)

[Start conditions]

Referring to the following conditions, start heating oil return operation.

- OR
- Integral oil rise rate is reached to specified level.
 - When cumulative compressor operating time exceeds 8 hours (2 hours when the power supply turns ON for the first time)

Furthermore, the integral oil rise rate is calculated by Tc, Te, and compressor loads.

The higher the compressor operating step No., the cumulative refrigerant oil consumption increases.

Actuator	Symbol	Elect. symbol		Oil return operation
		REYQ	REMQ	
Compressor 1	—	M1C	M1C	Maintain load that was applied before oil return operation. When current circulation rate < circulation rate required for oil return operation, turn ON the STD compressor every 10 seconds (up to 3 units at maximum).
Compressor 2		M2C	M2C	
Compressor 3		—	M3C	
Outdoor unit fan 1	—	M1F	M1F	When outdoor unit heat exchanger is condenser, the fan will run under cooling fan control. When outdoor unit heat exchanger is evaporator, the fan will run at the fan step 7 or 8.
Outdoor unit fan 2		M2F	M2F	
Electronic expansion valve (main)	EVM	Y1E Y3E	Y1E	20SA=ON : PI control 20SA=OFF : 418pls
Electronic expansion valve (subcooling)	EVT	Y2E Y5E	Y3E	PI control
Electronic expansion valve (refilling refrigerant)	EVJ	Y4E	Y2E	80pls
Four way valve (for heat changer selection)	20SA	Y2S Y9S	Y3S	When outdoor unit heat exchanger is condenser, the valve will turn OFF. When outdoor unit heat exchanger is evaporator, the valve will turn ON.
Four way valve (for high- and low-pressure gas pipe selection)	20SB	Y8S	Y2S	OFF
Solenoid valve (main bypass)	SVE	Y5S Y10S	Y6S	OFF
Solenoid valve (hot gas)	SVP	Y4S	Y5S	0pls
Solenoid valve (liquid pipe of refrigerant regulator)	SVL	Y3S	Y4S	0pls
Solenoid valve (gas discharge pipe of refrigerant regulator)	SVG	Y1S	Y1S	0pls
Solenoid valve (drain pipe of refrigerant regulator)	SVO	Y7S	Y7S	0pls
Solenoid valve (discharge pipe of refrigerant regulator)	SVT	Y6S	Y8S	0pls
End conditions				or <ul style="list-style-type: none"> • Pe_min<0.22MPa • After a lapse of 9 min.

*1: In case of multi outdoor unit system:

Master unit: It conducts the operation listed in the table above.

Slave units: Operating units conduct the operation listed in the table above.

Non-operating units conduct the operation listed in the table above after the "Oil returning" process.
(Non-operating units stop while in "Preparation" mode.)

Cooling indoor unit actuator		Oil return operation
Fan	Thermo ON unit	Remote control setting
	Unit not in operation	OFF
	Thermo OFF unit	Remote control setting
Motorized valve	Thermo ON unit	Normal opening degree
	Unit not in operation	192pls
	Thermo OFF unit	Normal opening degree for forced thermostat ON

Heating indoor unit actuator		Oil return operation
Fan	Thermo ON unit	Remote control setting
	Unit not in operation	OFF
	Thermo OFF unit	LL
Motorized valve	Thermo ON unit	Normal opening degree
	Unit not in operation	224 pls
	Thermo OFF unit	Normal opening degree for forced thermostat ON

Cooling BS unit actuator	Elect. symbol	Oil return operation
Electronic expansion vale (EVH)	Y4E	0pls
Electronic expansion vale (EVL)	Y5E	760pls
Electronic expansion vale (EVHS)	Y2E	0pls (60pls when Pc_max>2.85MPa)
Electronic expansion vale (EVLS)	Y3E	480pls
Electronic expansion vale (EVSC)	Y1E	PI control

Heating BS unit actuator	Elect. symbol	Oil return operation
Electronic expansion vale (EVH)	Y4E	760pls
Electronic expansion vale (EVL)	Y5E	0pls
Electronic expansion vale (EVHS)	Y2E	60pls
Electronic expansion vale (EVLS)	Y3E	0pls (60pls when Pc_max>2.85MPa)
Electronic expansion vale (EVSC)	Y1E	0pls (PI control at simultaneous cooling / heating operation)

3.4 Defrost Operation

[Start conditions]

Referring to the following conditions, start defrost operation.

- & {
 - When there is a decrease in the coefficient of heat transfer of outdoor unit heat exchanger
 - When there is a drop in the temperature of outdoor unit heat exchanger outlet (Tb)
 - When the low pressure stays low for a certain amount of time (2 hours minimum)

Furthermore, the thermal conductivity of outdoor unit heat exchanger is calculated by Tc, Te, and compressor loads.

Defrosting outdoor unit actuator	Symbol	Elect. symbol		Defrost operation	Operation after defrost
		REYQ	REMQ		
Compressor 1	—	M1C	M1C	REYQ8•10•12P: 232Hz+ON REYQ14•16P: 232Hz+232Hz REMQ8P: 210Hz REMQ10•12P: 210Hz+ON REMQ14•16P: 202Hz+ON+ON	REYQ8•10•12P: upper limit 124Hz(STD Holds) REYQ14•16P: 232Hz+232Hz REMQ8P: 210Hz REMQ10•12P: 210Hz+ON REMQ14•16P: 210Hz+ON+ON
Compressor 2		M2C	M2C		
Compressor 3		—	M3C		
Outdoor unit fan 1	—	M1F	M1F	Pcmax>2.45MPa ↓ ↑ Pcmax<2.36MPa OFF FANSTEP4	Pcmax>2.45MPa ↓ ↑ Pcmax<2.36MPa OFF FANSTEP4
Outdoor unit fan 2		M2F	M2F	Pcmax>3.04MPa ↓ ↑ Pcmax<2.95MPa OFF FANSTEP6	Pcmax>3.04MPa ↓ ↑ Pcmax<2.95MPa OFF FANSTEP6
Four way valve (for heat changer selection)	20SA	Y2S Y9S	Y3S	OFF	OFF
Four way valve (for high- and low-pressure gas pipe selection)	20SB	Y8S	Y2S	Holds	Holds
Electronic expansion valve (main)	EVM	Y1E Y3E	Y1E	1375pls	0pls
Electronic expansion valve (subcooling)	EVT	Y2E Y5E	Y3E	SH control	0pls
Electronic expansion valve (refilling refrigerant)	EVJ	Y4E	Y2E	80pls	80pls
Solenoid valve (main bypass)	SVE	Y5S Y10S	Y6S	ON	OFF
Solenoid valve (hot gas)	SVP	Y4S	Y5S	OFF	OFF
Solenoid valve (liquid pipe of refrigerant regulator)	SVL	Y3S	Y4S	0pls	0pls
Solenoid valve (gas discharge pipe of refrigerant regulator)	SVG	Y1S	Y1S	0pls	0pls
Solenoid valve (drain pipe of refrigerant regulator)	SVO	Y7S	Y7S	0pls	0pls
Solenoid valve (discharge pipe of refrigerant regulator)	SVT	Y6S	Y8S	0pls	0pls
End conditions				REYP8 to 16P (by unit) or { <ul style="list-style-type: none"> • 6 min. and 30 sec. • Tb > 11°C continues for a period of 90 consecutive sec. • Pc_max > 3.04MP REMQ8 to 12P (by unit) or { <ul style="list-style-type: none"> • 5 min. and 30 sec. • Tb > 11°C for a period of 10 consecutive sec. • Pc_max > 3.04MPa REMQ14 and 16P (by unit) or { <ul style="list-style-type: none"> • 5 min. and 30 sec. • Tb > 11°C for a period of 30 consecutive sec. • Pc_max > 3.04MPa 	or { <ul style="list-style-type: none"> • 30 sec. • Pc_max>3.04MPa

Evaporating outdoor unit actuator	Symbol	Elect. symbol		Defrost operation	Operation after defrost
		REYQ	REMQ		
Compressor 1	—	M1C	M1C	REYQ8•10•12P: 232Hz+ON REYQ14•16P: 232Hz+232Hz REMQ8P: 210Hz REMQ10•12P: 210Hz+ON REMQ14•16P: 210Hz+ON+ON	Upper limit 124Hz (STD Holds) REYP400•480A: 232Hz+232Hz REMP224A: 210Hz REMP280•335A: 210Hz+ON REMP400•450A: 210Hz+ON+ON
Compressor 2		M2C	M2C		
Compressor 3		M3C	M3C		
Outdoor unit fan 1	—	M1F	M1F	Fan control	Fan control
Outdoor unit fan 2		M2F	M2F		
Four way valve (for heat changer selection)	20SA	Y2S Y9S	Y3S	ON	ON
Four way valve (for high- and low-pressure gas pipe selection)	20SB	Y8S	Y2S	Holds	Holds
Electronic expansion valve (main)	EVM	Y1E Y3E	Y1E	PI control	PI control
Electronic expansion valve (subcooling)	EVT	Y2E Y5E	Y3E	SH control	0pls
Electronic expansion valve (refilling refrigerant)	EVJ	Y4E	Y2E	80pls	80pls
Solenoid valve (main bypass)	SVE	Y5S Y10S	Y6S	OFF	OFF
Solenoid valve (hot gas)	SVP	Y4S	Y5S	OFF	OFF
Solenoid valve (liquid pipe of refrigerant regulator)	SVL	Y3S	Y4S	0pls	0pls
Solenoid valve (gas discharge pipe of refrigerant regulator)	SVG	Y1S	Y1S	0pls	0pls
Solenoid valve (drain pipe of refrigerant regulator)	SVO	Y7S	Y7S	0pls	0pls
Solenoid valve (discharge pipe of refrigerant regulator)	SVT	Y6S	Y8S	0pls	0pls

Cooling indoor unit actuator		Defrost operation	
Fan	Thermo ON unit	Remote control setting	
	Unit not in operation	OFF	
	Thermo OFF unit	Remote control setting	
Motorized valve	Thermo ON unit	Normal opening degree	
	Unit not in operation	0pls	
	Thermo OFF unit	0pls	

Heating indoor unit actuator		Defrost operation	
		REYQ	REMQ
Fan	Thermo ON unit	OFF	LL
	Unit not in operation	OFF	LL
	Thermo OFF unit	OFF	LL
Motorized valve	Thermo ON unit	0pls	224pls
	Unit not in operation	0pls	0pls
	Thermo OFF unit	0pls	224pls

Cooling BS unit actuator	Elect. symbol	Defrost operation
Electronic expansion vale (EVH)	Y4E	0pls
Electronic expansion vale (EVL)	Y5E	760pls
Electronic expansion vale (EVHS)	Y2E	0pls
Electronic expansion vale (EVLS)	Y3E	480pls
Electronic expansion vale (EVSC)	Y1E	0pls

Heating BS unit actuator	Elect. symbol	Defrost operation
Electronic expansion vale (EVH)	Y4E	760pls
Electronic expansion vale (EVL)	Y5E	0pls
Electronic expansion vale (EVHS)	Y2E	60pls
Electronic expansion vale (EVLS)	Y3E	0pls (REYQ8~16P) 60pls (REMQ8~16P)
Electronic expansion vale (EVSC)	Y1E	0pls (PI control for cool/heat concurrent operation)

3.5 Pump-down Residual Operation

3.5.1 Pump-down Residual Operation in Cooling Operation

If the liquid refrigerant stays in the Evaporator at the startup of a compressor, this liquid refrigerant enters the compressor, thus resulting in diluted oil in the compressor and then degraded lubrication performance.

Consequently, in order to recover the refrigerant in the Evaporator while the compressor stops, the pump-down residual operation is conducted.

Actuator	Symbol	Elect. symbol		Master unit operation	Slave unit operation
		REYQ	REMQ		
Compressor 1	—	M1C	M1C	124 Hz+OFF+OFF	OFF
Compressor 2		M2C	M2C		
Compressor 3		M3C	M3C		
Outdoor unit fan 1	—	M1F	M1F	Fan control	Fan control
Outdoor unit fan 2		M2F	M2F		
Electronic expansion valve (Main)	EVM	Y1E Y3E	Y1E	1375 pls	1375 pls
Electronic expansion valve (Supercooling)	EVT	Y2E Y5E	Y3E	0 pls	0 pls
Electronic expansion valve (Refrigerant charge)	EVJ	Y4E	Y2E	80 pls	80 pls
Four way valve (Heat exchanger switch)	20SA	Y2S Y9S	Y3S	OFF	OFF
Four way valve (High/low pressure gas pipe switch)	20SB	Y8S	Y2S	ON	ON
Solenoid valve (Main bypass)	SVE	Y5S Y10S	Y6S	ON	ON
Solenoid valve (Hot gas)	SVP	Y4S	Y5S	OFF	OFF
Solenoid valve (Refrigerant regulator liquid pipe)	SVL	Y3S	Y4S	OFF	OFF
Solenoid valve (Refrigerant regulator gas vent pipe)	SVG	Y1S	Y1S	OFF	OFF
Solenoid valve (Refrigerant regulator exhaust pipe)	SVO	Y7S	Y7S	OFF	OFF
Solenoid valve (Refrigerant regulator discharge pipe)	SVT	Y6S	Y8S	OFF	OFF
Ending conditions	or <ul style="list-style-type: none"> • 5 min. • Pe_min<0.49 MPa * • Pc_max<2.94 MPa * • Master unit Tdi>110°C • Master unit Tp>125°C 				

* Pe_min and Pc_max indicate the minimum and maximum values in the system, respectively.

3.5.2 Pump-down Residual Operation in Heating Operation and Simultaneous Cooling / Heating Operation

Actuator	Symbol	Elect. symbol		Master unit operation	Slave unit operation
		REYQ	REMQ		
Compressor 1	—	M1C	M1C	124 Hz+OFF+OFF	OFF
Compressor 2		M2C	M2C		
Compressor 3		M3C	M3C		
Outdoor unit fan 1	—	M1F	M1F	Fan control	Fan control
Outdoor unit fan 2		M2F	M2F		
Electronic expansion valve (Main)	EVM	Y1E Y3E	Y1E	When 20SA=ON: 0 pls When 20SA=OFF: 1375 pls	When 20SA=ON: 0 pls When 20SA=OFF: 1375 pls
Electronic expansion valve (Supercooling)	EVT	Y2E Y5E	Y3E	0 pls	0 pls
Electronic expansion valve (Refrigerant charge)	EVJ	Y4E	Y2E	80 pls	80 pls
Four way valve (Heat exchanger switch)	20SA	Y2S Y9S	Y3S	When outdoor heat exchanger is evaporator: ON When outdoor heat exchanger is condenser: OFF	When outdoor heat exchanger is evaporator: ON When outdoor heat exchanger is condenser: OFF
Four way valve (High/low pressure gas pipe switch)	20SB	Y8S	Y2S	OFF	OFF
Solenoid valve (Main bypass)	SVE	Y5S Y10S	Y6S	OFF	OFF
Solenoid valve (Hot gas)	SVP	Y4S	Y5S	OFF	OFF
Solenoid valve (Refrigerant regulator liquid pipe)	SVL	Y3S	Y4S	OFF	OFF
Solenoid valve (Refrigerant regulator gas vent pipe)	SVG	Y1S	Y1S	OFF	OFF
Solenoid valve (Refrigerant regulator exhaust pipe)	SVO	Y7S	Y7S	OFF	OFF
Solenoid valve (Refrigerant regulator discharge pipe)	SVT	Y6S	Y8S	OFF	OFF
Ending conditions				or <ul style="list-style-type: none"> • 3 min. • Pe_min<0.25 MPa * • Pc_max<3.13 MPa * • Master unit Tdi>110°C • Master unit Tp>140°C 	

* Pe_min and Pc_max indicate the minimum and maximum values in the system, respectively.

3.6 Standby

3.6.1 Restart Standby

Used to forcedly stop the compressor for a period of 2 minutes, in order to prevent the frequent ON/OFF of the compressor and equalize the pressure within the refrigerant system.

Actuator	Symbol	Elect. symbol		Operation			
		REYQ	REMQ	REYQ8~16P	REMQ8P	REMQ10•12P	REMQ14•16P
Compressor1	—	M1C	M1C	OFF	OFF	OFF	OFF
Compressor2	—	M2C	M2C	OFF	—	OFF	OFF
Compressor3	—	M3C	M3C	—	—	—	OFF
Outdoor unit fan1	—	MF1	MF1	Ta>30°C: STEP4 Ta≤30°C: OFF	Ta>30°C: STEP4 Ta≤30°C: OFF	Ta>30°C: STEP4 Ta≤30°C: OFF	Ta>30°C: STEP4 Ta≤30°C: OFF
Outdoor unit fan2	—	MF2	MF2	Ta>30°C: STEP4 Ta≤30°C: OFF	—	—	Ta>30°C: STEP4 Ta≤30°C: OFF
Electronic expansion valve (Main)	EVM	Y1E Y3E	Y1E	0 pls			
Electronic expansion valve (Supercooling)	EVT	Y2E Y5E	Y3E	0 pls			
Electronic expansion valve (Refrigerant charge)	EVJ	Y4E	Y2E	80 pls			
Four way valve (Heat exchanger switch)	20SA	Y2S Y9S	Y3S	Holds			
Four way valve (High/low pressure gas pipe switch)	20SB	Y8S	Y2S	Holds			
Solenoid valve (Main bypass)	SVE	Y5S Y10S	Y6S	OFF			
Solenoid valve (Hot gas)	SVP	Y4S	Y5S	OFF			
Solenoid valve (Refrigerant regulator liquid pipe)	SVL	Y3S	Y4S	OFF			
Solenoid valve (Refrigerant regulator gas vent pipe)	SVG	Y1S	Y1S	OFF			
Solenoid valve (Refrigerant regulator exhaust pipe)	SVO	Y7S	Y7S	OFF			
Solenoid valve (Refrigerant regulator discharge pipe)	SVT	Y6S	Y8S	OFF			
Ending conditions	—			2 min.			

3.6.2 Crankcase Heater Control

In order to prevent the refrigerant from melting in the compressor oil in the stopped mode, this mode is used to control the crankcase heater.

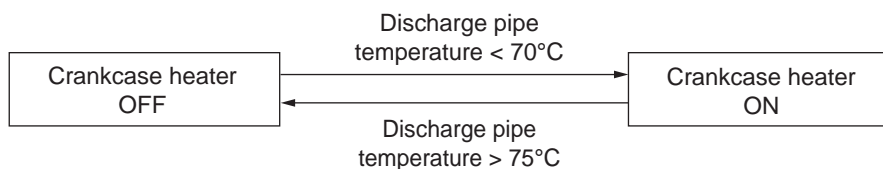

3.7 Stopping Operation

3.7.1 When System is in Stop Mode (Normal operation stop)

This mode is used to define actuator operations when the system stops.

Actuator	Symbol	Elect. symbol		Operation			
		REYQ	REMQ	REYQ8~16P	REMQ8P	REMQ10•12P	REMQ14•16P
Compressor1	—	M1C	M1C	OFF	OFF	OFF	OFF
Compressor2	—	M2C	M2C	OFF	—	OFF	OFF
Compressor3	—	M3C	M3C	—	—	—	OFF
Outdoor unit fan1	—	M1F	M1F	OFF	OFF	OFF	OFF
Outdoor unit fan2	—	M2F	M2F	OFF	—	—	OFF
Electronic expansion valve (Main)	EVM	Y1E Y3E	Y1E	0 pls			
Electronic expansion valve (Supercooling)	EVT	Y2E Y5E	Y3E	0 pls			
Electronic expansion valve (Refrigerant charge)	EVJ	Y4E	Y2E	80 pls			
Four way valve (Heat exchanger switch)	20SA	Y2S Y9S	Y3S	Holds			
Four way valve (High/low pressure gas pipe switch)	20SB	Y8S	Y2S	Holds			
Solenoid valve (Main bypass)	SVE	Y5S Y10S	Y6S	OFF			
Solenoid valve (Hot gas)	SVP	Y4S	Y5S	OFF			
Solenoid valve (Refrigerant regulator liquid pipe)	SVL	Y3S	Y4S	OFF			
Solenoid valve (Refrigerant regulator gas vent pipe)	SVG	Y1S	Y1S	OFF			
Solenoid valve (Refrigerant regulator exhaust pipe)	SVO	Y7S	Y7S	OFF			
Solenoid valve (Refrigerant regulator discharge pipe)	SVT	Y6S	Y8S	OFF			
Ending conditions	—	Indoor unit thermostat is turned ON.					

3.7.2 Stop due to Malfunction

In order to protect compressors, if any of the following items has an abnormal value, the system will make "stop with thermostat OFF" and the malfunction will be determined according to the number of retry times.

Item	Judgment Criteria	Malfunction Code
1. Abnormal low pressure level	0.07MPa	E4
2. Abnormal high pressure level	4.0MPa	E3
3. Abnormal discharge pipe temperature level	135°C	F3
4. Abnormal power supply voltage	Reverse-phase power supply	U1
5. Abnormal inverter current level	16.1A: 260 sec.	L8
6. Abnormal radiator fin temperature level	93°C	L4

4. Protection Control

4.1 High Pressure Protection Control

This high pressure protection control is used to prevent the activation of protection devices due to abnormal increase of high pressure and to protect compressors against the transient increase of high pressure.

[In cooling operation]

- ★ The following control is performed in the entire system.
Pc_max indicates the maximum value within the system.

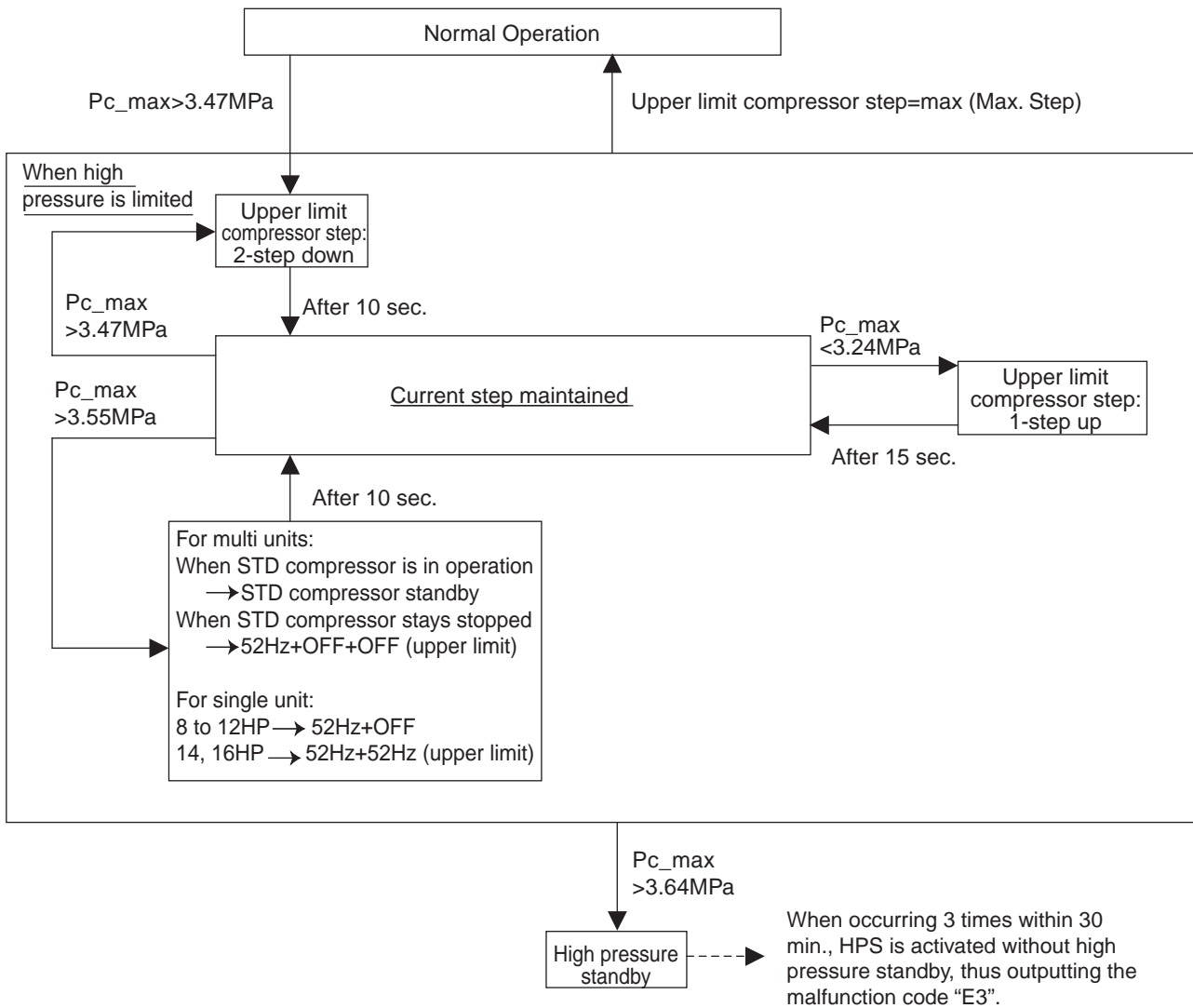

[Heating Operation and Simultaneous Cooling / Heating Operation]

- ★ The following control is performed in the entire system.
Pc_max indicates the maximum value within the system.

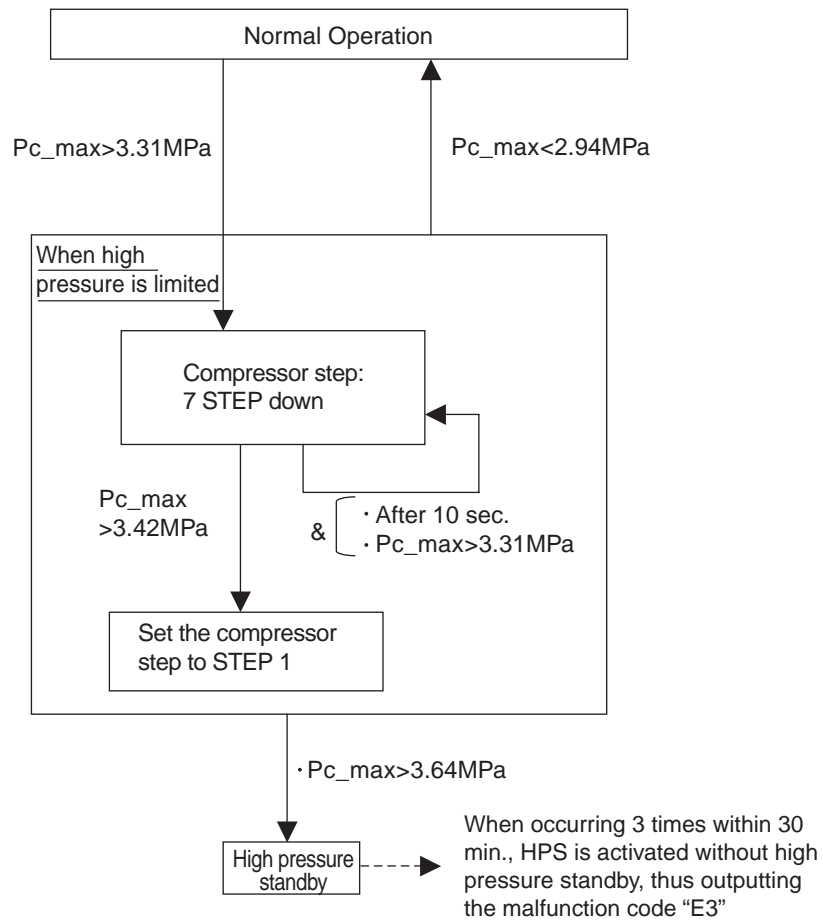

4.2 Low Pressure Protection Control

This low pressure protection control is used to protect compressors against the transient decrease of low pressure.

[In cooling operation]

- ★ Because of common low pressure, the following control is performed in the system.
Pe_min indicates the minimum value within the system.

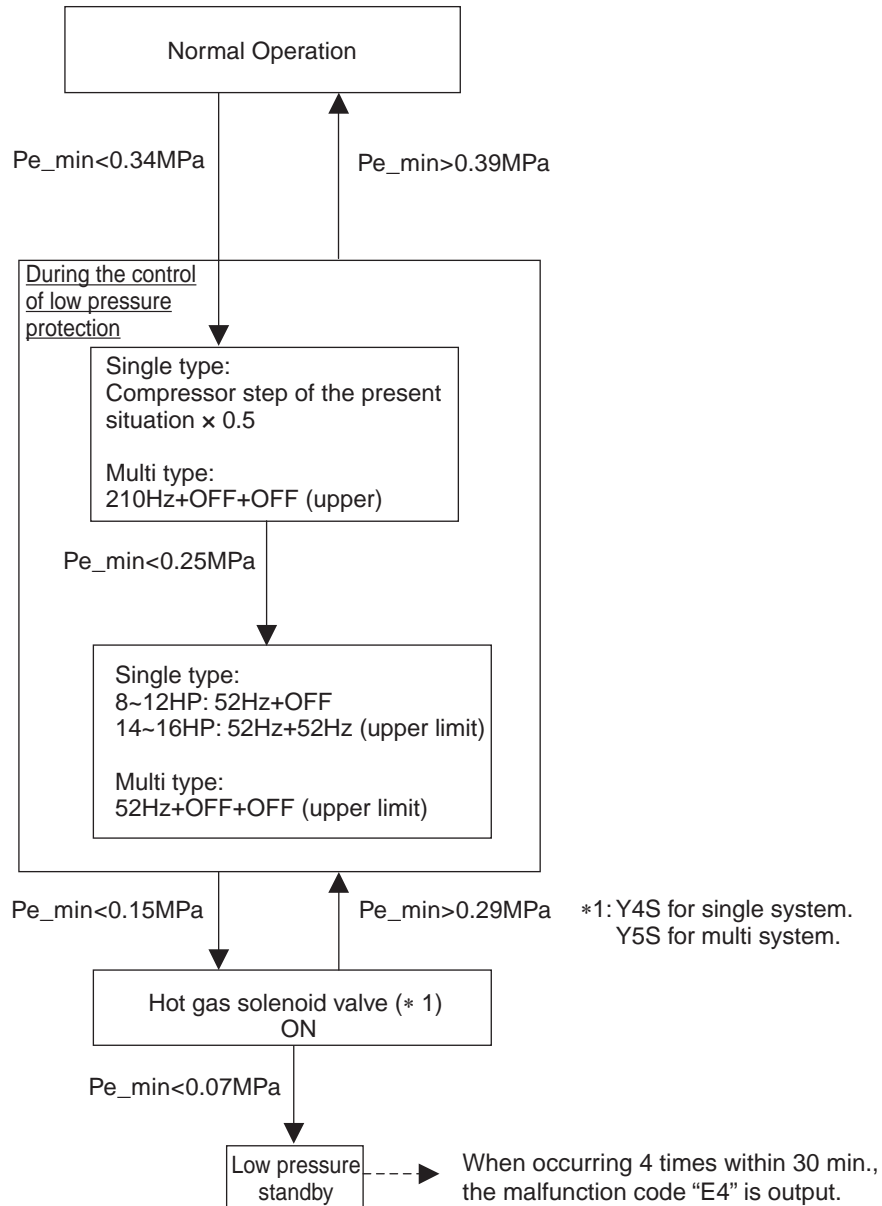

[In heating operation and Simultaneous Cooling / Heating Operation]

- ★ The following control is performed in the system.
 Pe_{min} indicates the minimum value within the system.

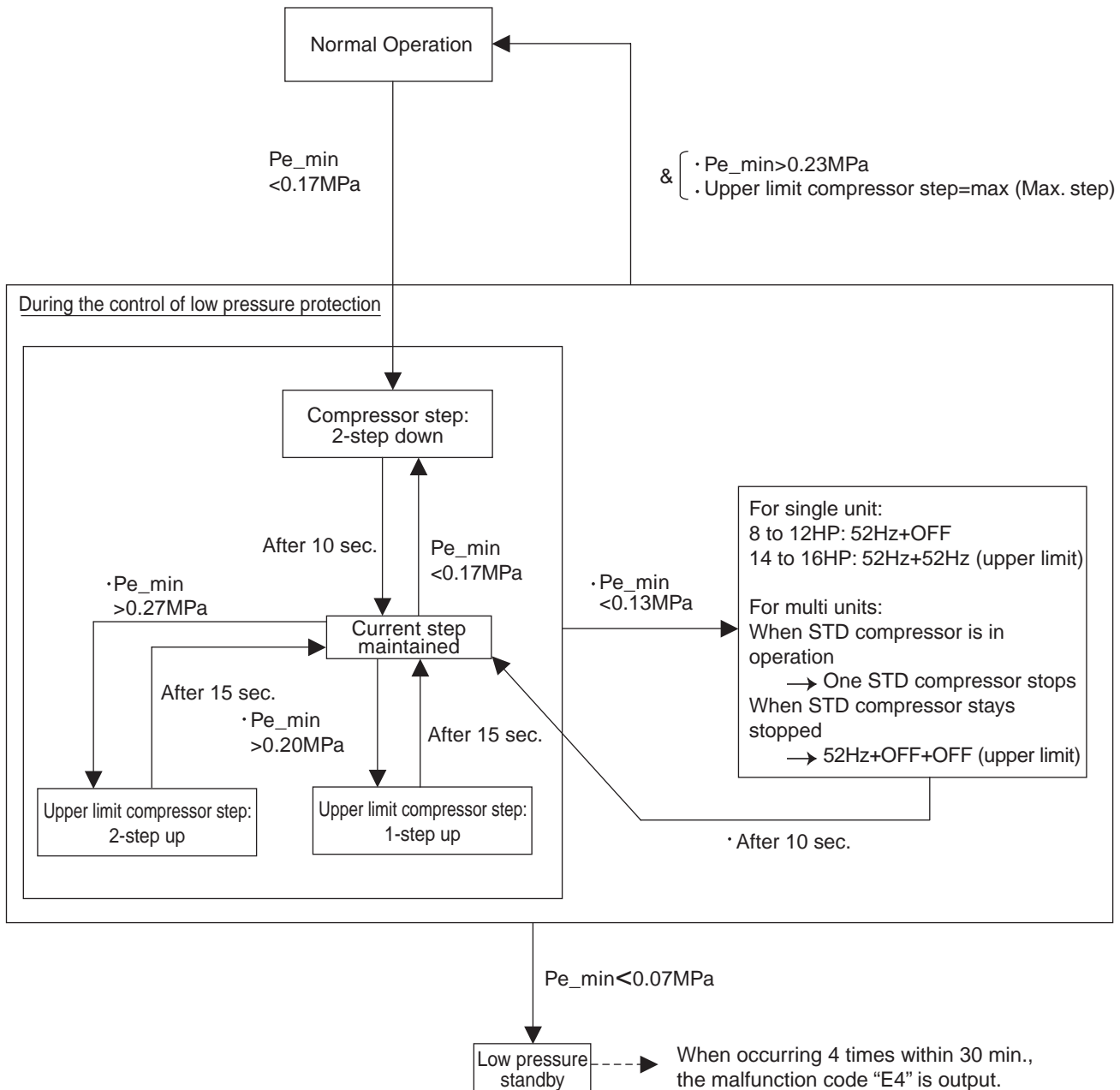

4.3 Discharge Pipe Protection Control

This discharge pipe protection control is used to protect the compressor internal temperature against a malfunction or transient increase of discharge pipe temperature.

[Contents]

★ The following control is performed for each compressor of single unit as well as multi units.

[INV compressor]

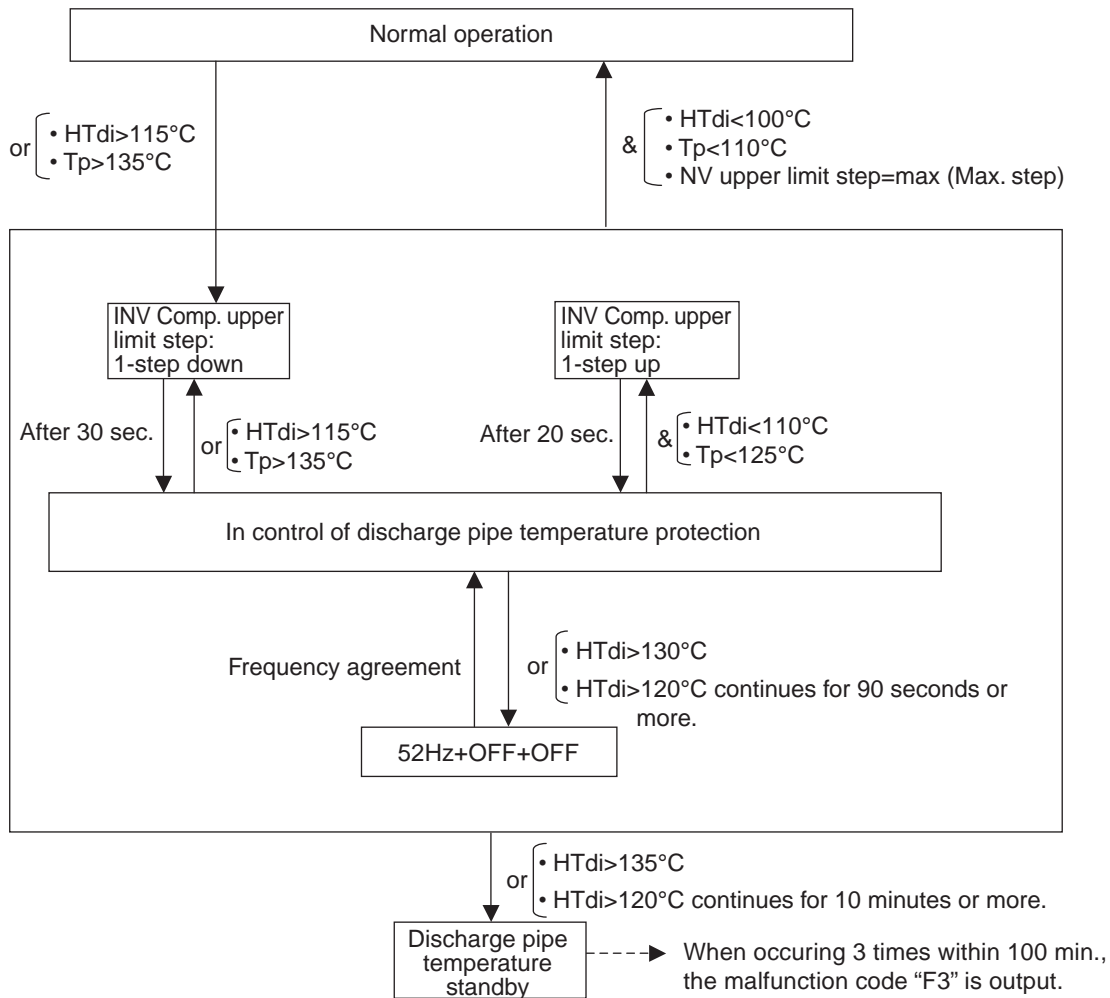

[STD compressor]

HTds: Value of STD compressor discharge pipe temperature (Tds) compensated with outdoor air temperature.

Tp : Value of compressor port temperature calculated by Tc and Te, and suction superheated degree.

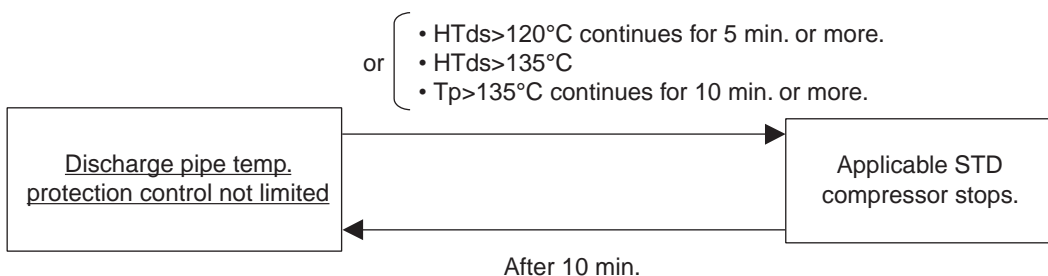

4.4 Inverter Protection Control

Inverter current protection control and inverter fin temperature control are performed to prevent tripping due to a malfunction, or transient inverter overcurrent, and fin temperature increase.

- ★ In the case of multi-outdoor-unit system, each INV compressor performs these controls in the following sequence.

[Inverter overcurrent protection control]

- ★ Perform the following control of integrated as well as multi units for each INV compressor.

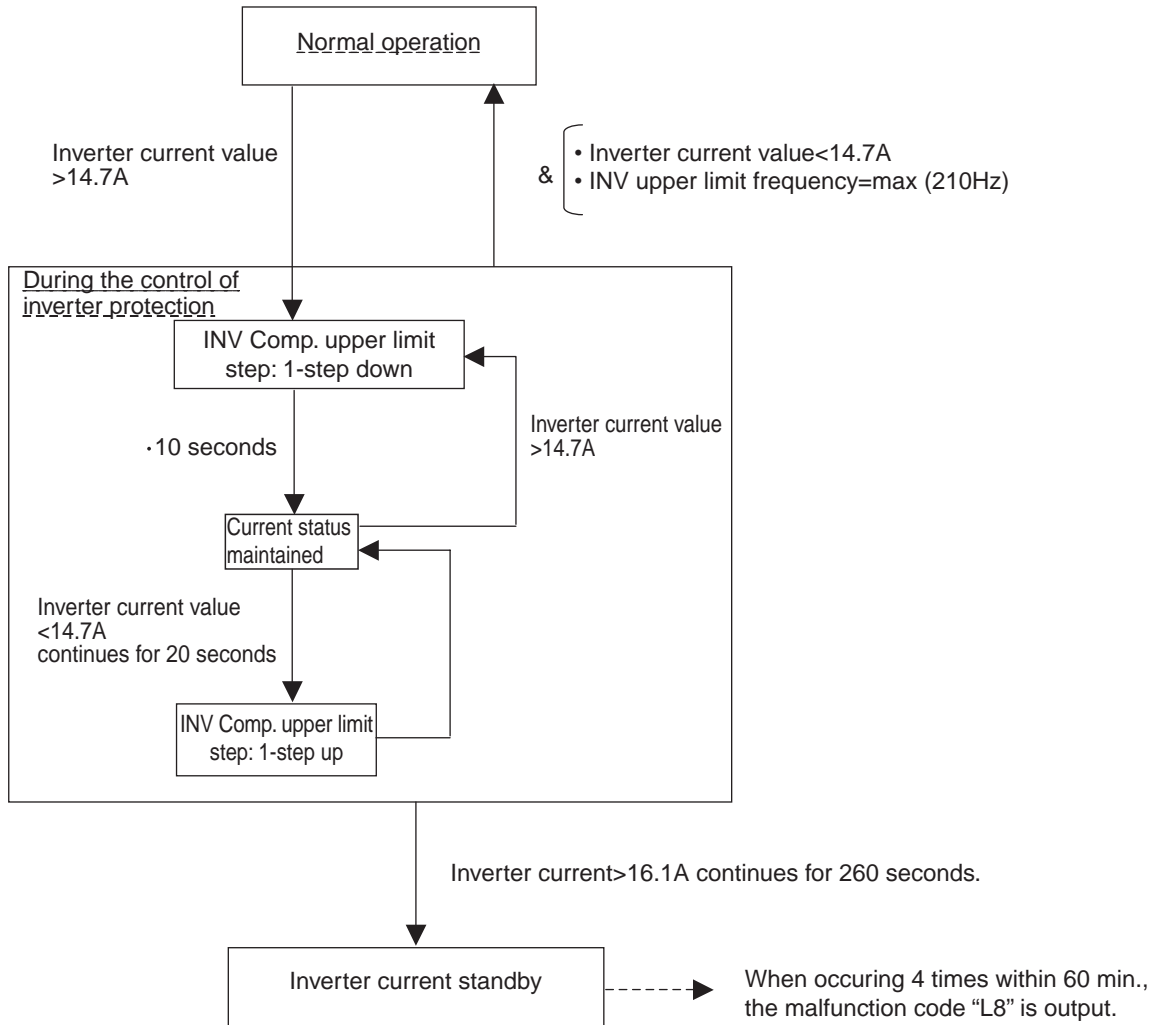

[Inverter fin temperature control]

★ Perform the following control of integrated as well as multi units for each INV compressor.

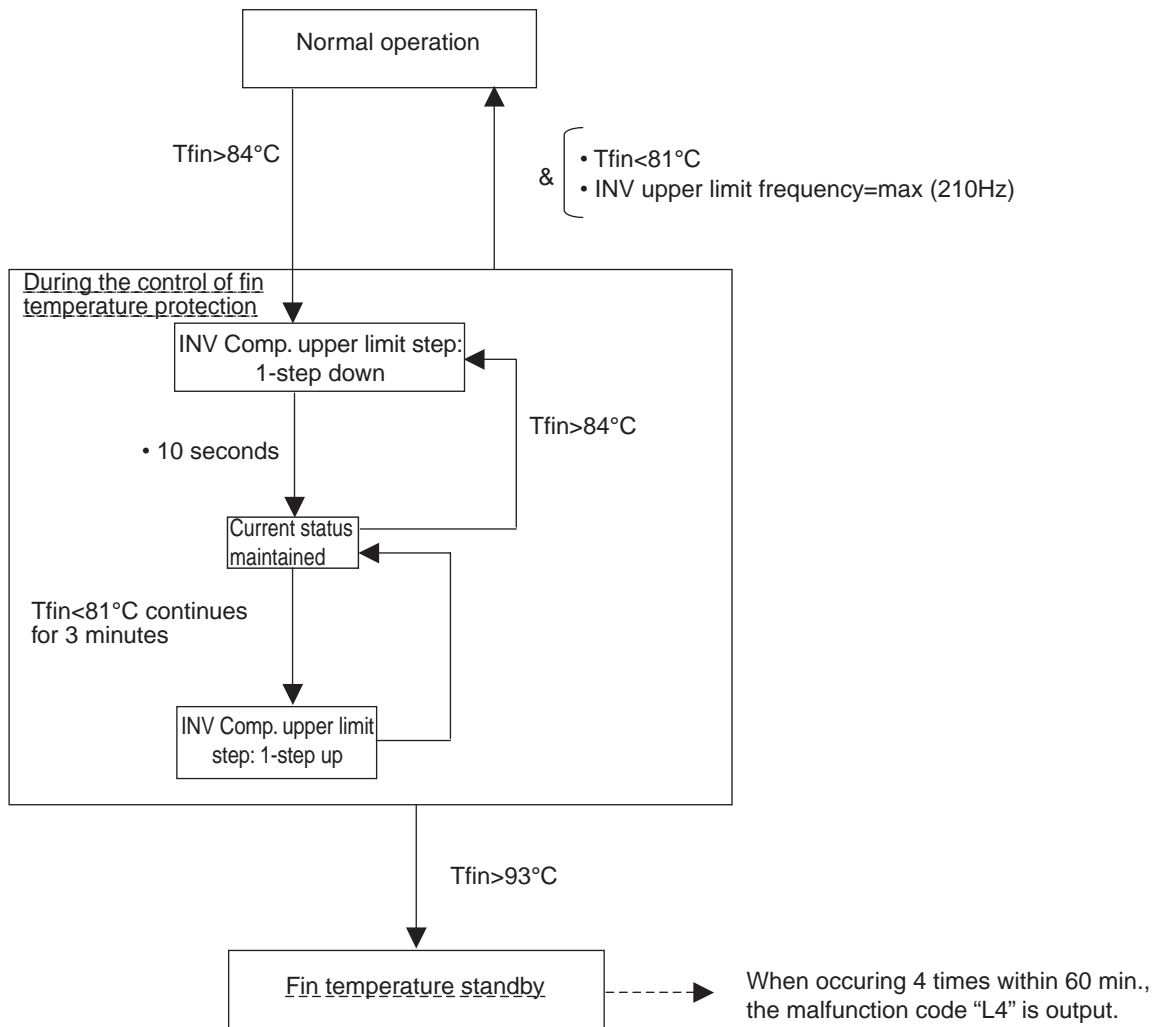

4.5 STD Compressor Overload Protection

This control is used to prevent abnormal heating due to overcurrent to the compressor resulting from failures of STD compressor such as locking.

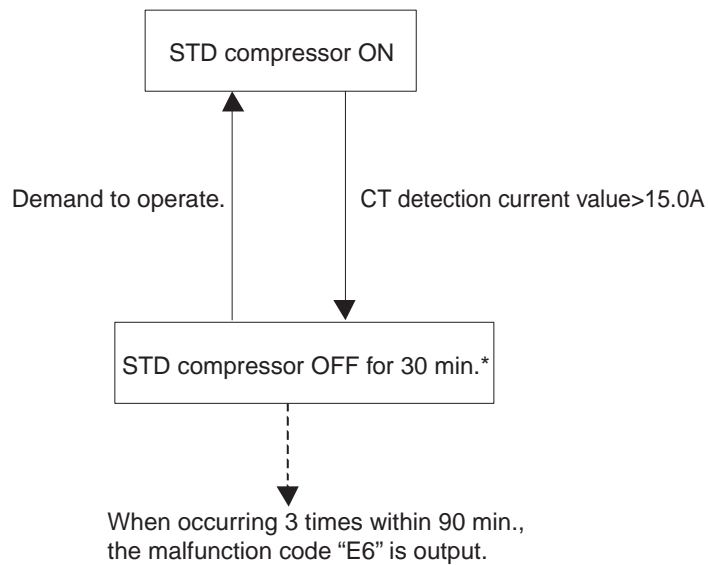

*If the power supply is reset while in operation prohibition mode, the prohibition timer will continue counting when the power supply is turned ON.

5. Other Control

5.1 Backup Operation

If any of the compressors goes wrong, disable the relevant compressor or the relevant outdoor unit from operating, and then conduct emergency operation only with operational compressors or outdoor units.

"Emergency operation with remote control reset" and "Emergency operation with outdoor unit PC board setting" are available

Applicable model \ Operating method	(1) Emergency operation with remote control reset (Auto backup operation)	(2) Emergency operation with outdoor unit PC board setting (Manual backup operation)
REYQ8 ~ 16PY1	—	Backup operation by the compressor
REYQ18 ~ 48PY1	Backup operation by the indoor unit	Backup operation by the outdoor unit

(1) Emergency operation with remote control reset

[Operating method]

Reset the remote control. (Press the **RUN/STOP** button for 4 seconds or more.)

[Details of operation]

Disable the defective outdoor unit from operating, and then only operate other outdoor units.

(On systems with 1 outdoor unit, this emergency operation is not available.)

(2) Emergency operation with outdoor unit PC board setting

[Setting method]

Make setting of the compressor, "the operation of which is to be disabled", in field setting mode (setting mode 2).

(For detail of the setting method, refer to page 204.)

[Details of operation]

Disable the compressor with "operation disable setting" made from operating and only operate other compressors.

(On the system with 1 compressor "REYQ8PY1", this emergency operation is not available.)

5.2 Demand Operation

In order to save the power consumption, the capacity of outdoor unit is saved with control forcibly by using "Demand 1 Setting" or "Demand 2 Setting".

To operate the unit with this mode, additional setting of "Continuous Demand Setting" or external input by external control adapter is required.

Set item	Condition	Content
Demand 1	Mode 1	The compressor operates at approx. 60% or less of rating.
	Mode 2	The compressor operates at approx. 70% or less of rating.
	Mode 3	The compressor operates at approx. 80% or less of rating.
Demand 2	—	The compressor operates at approx. 40% or less of rating.

5.3 Heating Operation Prohibition

Heating operation is prohibited above 24°C ambient temperature.

6. Outline of Control (Indoor Unit)

6.1 Operation Flow Chart

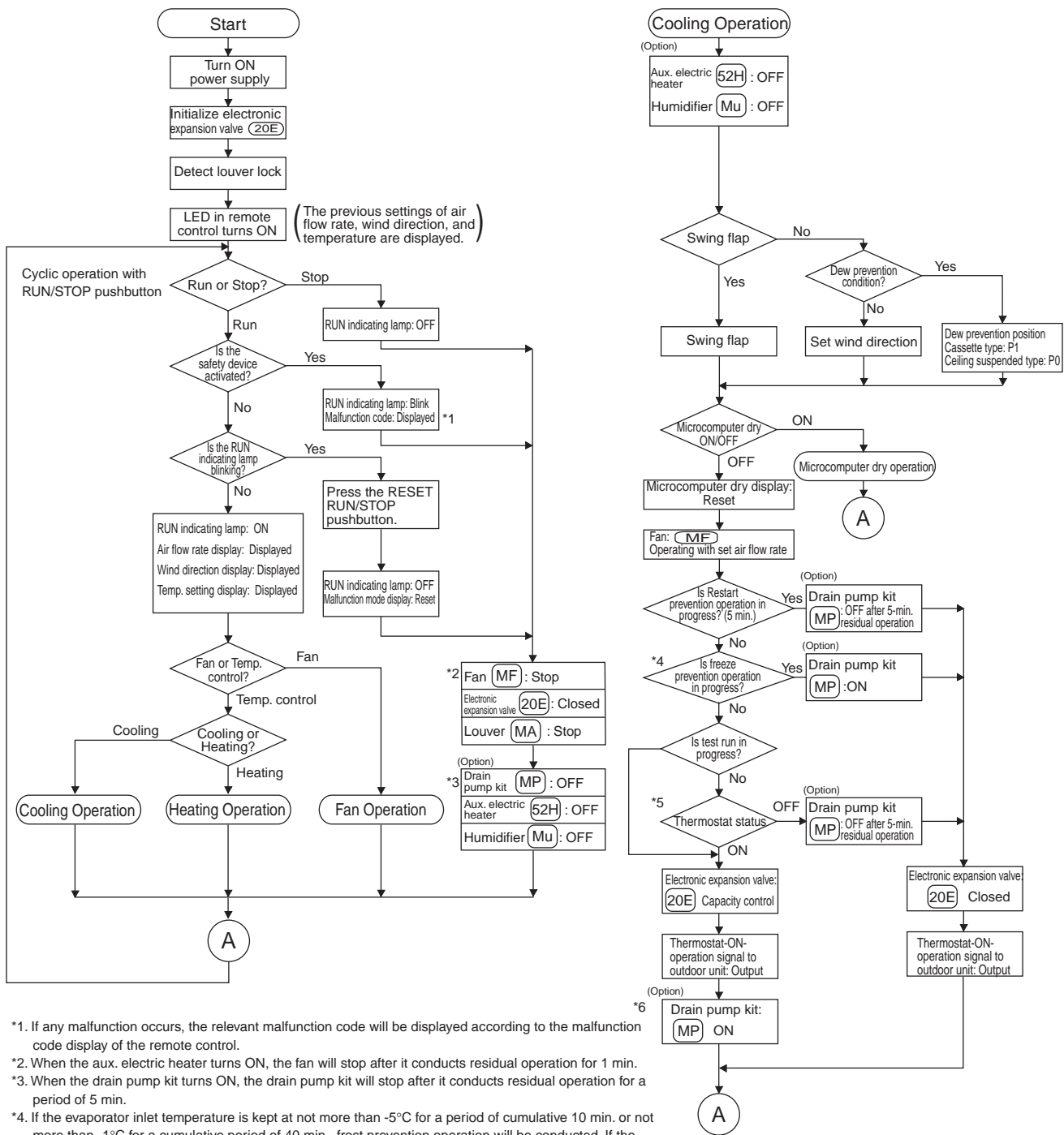

- *1. If any malfunction occurs, the relevant malfunction code will be displayed according to the malfunction code display of the remote control.
- *2. When the aux. electric heater turns ON, the fan will stop after it conducts residual operation for 1 min.
- *3. When the drain pump kit turns ON, the drain pump kit will stop after it conducts residual operation for a period of 5 min.
- *4. If the evaporator inlet temperature is kept at not more than -5°C for a period of cumulative 10 min. or not more than -1°C for a cumulative period of 40 min., frost prevention operation will be conducted. If the evaporator inlet temperature is kept at not less than 7°C for a consecutive period of 10 min., the frost prevention operation will be reset.
- *5. Thermostat status

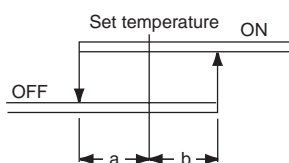

Suction air temperature
 a=b=1
 (a=b=0.5 is only available for the FXCQ, FXFQ, FXHQ, and FXKQ series.)

*6. The FXCQ, FXFQ, FXKQ, and FXSQ series have the drain pump as standard equipment.

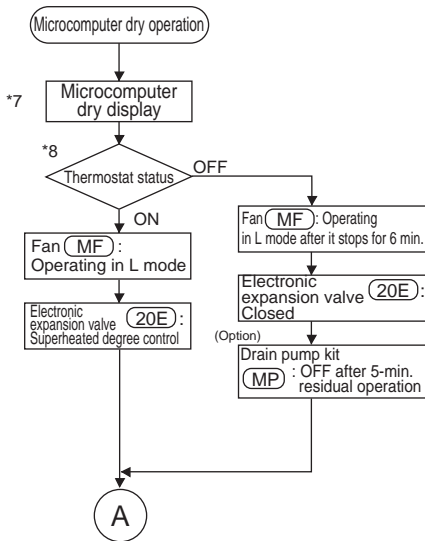

- *7. Microcomputer dry display
No set temperature and air flow rate of the remote controller are displayed.
- *8. Thermostat status
Set temperature when operating the microcomputer dry mechanism.

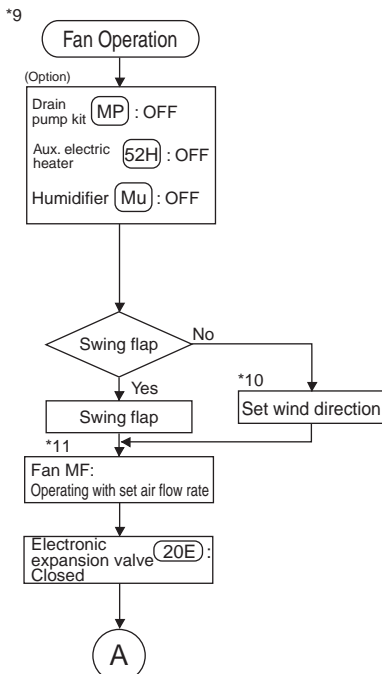
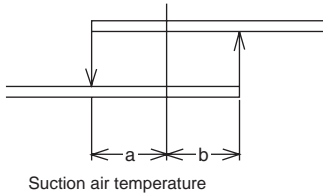

- *9. Fan operation
By setting the remote controller to Fan, the fan will operate with thermostat OFF in set temperature control operation mode.
- *10. Set wind direction
According to wind direction instruction from the remote controller, the wind direction is set to 100% horizontal while in heating operation.
- *11. Fan
According to fan speed instruction from the remote controller, the fan is put into operation in LL mode while in heating operation.

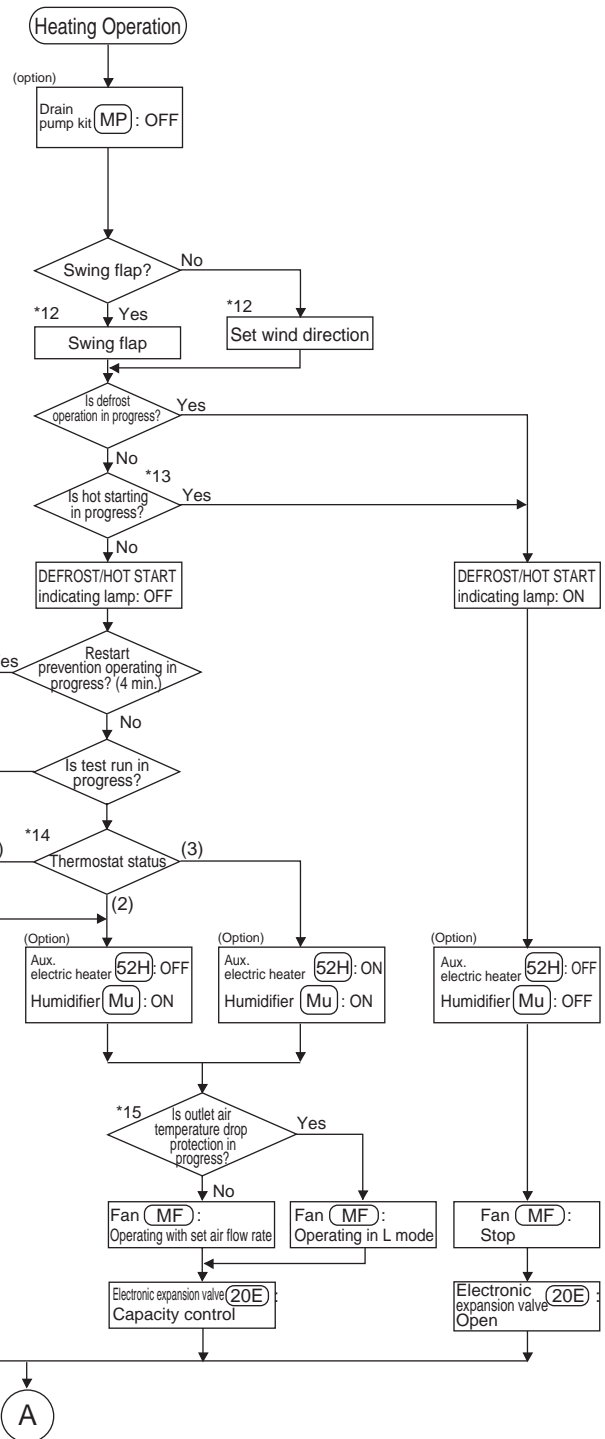

- *12. Wind direction
When the heating thermostat turns OFF, the wind direction will be set to 100% horizontal.
 - *13. Hot start
If the condenser inlet temperature exceeds 34°C at the time of starting operation or after the completion of defrost operation, or until 3 minutes pass or Tc is above 52°C, hot starting will be conducted.
 - *14. Thermostat status
-
- *15. Outlet air temperature drop protection
When the set temperature is below 24°C or the electronic expansion valve opening is small, the protection will be activated.

6.2 Thermostat Control

6.2.1 Thermostat Sensor in Remote Control

Temperature is controlled by both the thermostat sensor in remote control and air suction thermostat in the indoor unit. (This is however limited to when the field setting for the thermostat sensor in remote control is set to "Use" .)

Cooling

If there is a significant difference in the preset temperature and the suction temperature, fine adjustment control is carried out using a body thermostat sensor, or using the sensor in the remote control near the position of the user when the suction temperature is near the preset temperature.

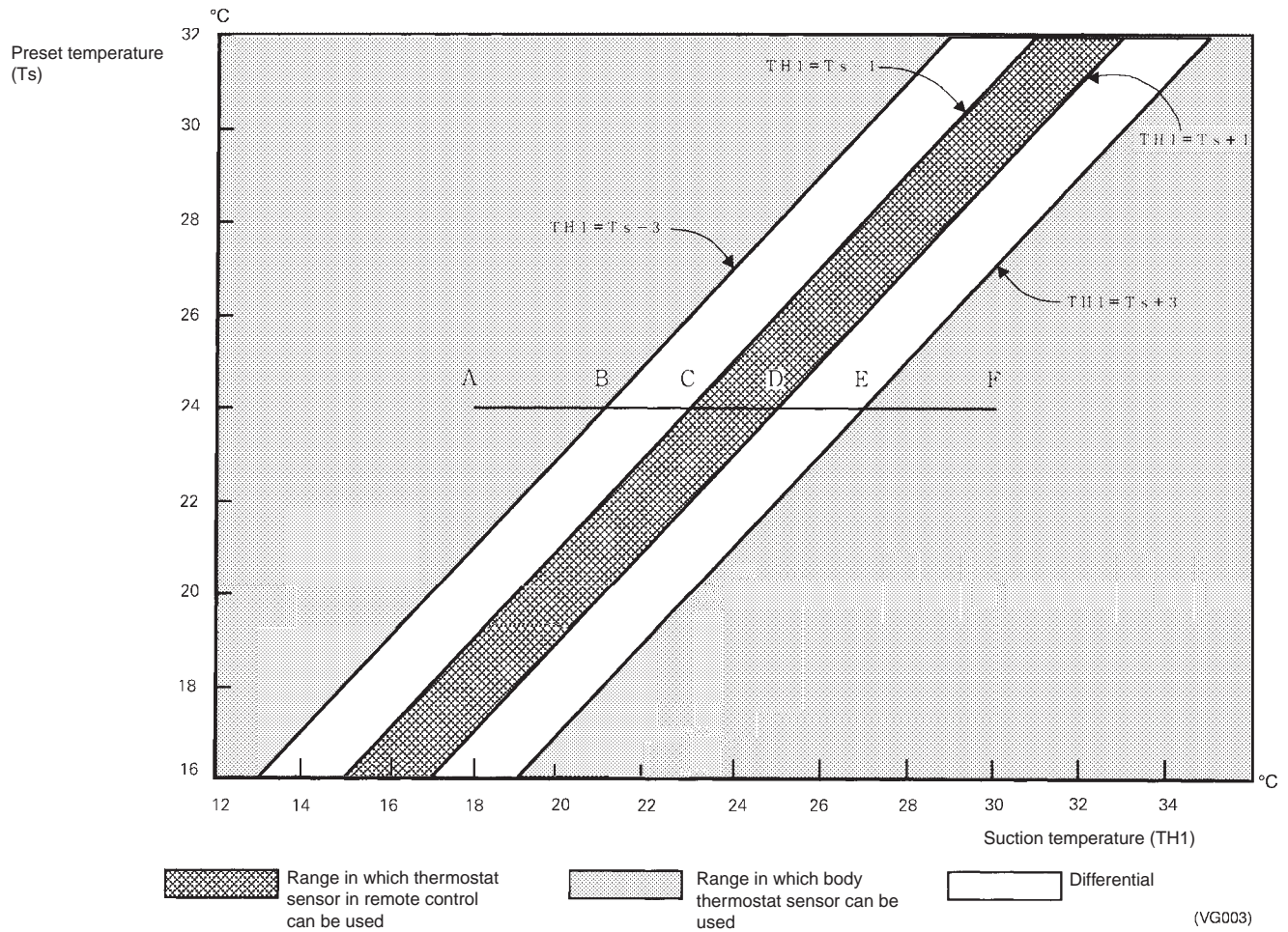

■ **Ex: When cooling**

Assuming the preset temperature in the figure above is 24°C, and the suction temperature has changed from 18°C to 30°C (A → F):

(This example also assumes there are several other air conditioners, the VRV system is off, and that temperature changes even when the thermostat sensor is off.)

Body thermostat sensor is used for temperatures from 18°C to 23°C (A → C).

Remote control thermostat sensor is used for temperatures from 23°C to 27°C (C → E).

Body thermostat sensor is used for temperatures from 27°C to 30°C (E → F).

And, assuming suction temperature has changed from 30°C to 18°C (F → A):

Body thermostat sensor is used for temperatures from 30°C to 25°C (F → D).

Remote control thermostat sensor is used for temperatures from 25°C to 21°C (D → B).

Body thermostat sensor is used for temperatures from 21°C to 18°C (B → A).

Heating

When heating, the hot air rises to the top of the room, resulting in the temperature being lower near the floor where the occupants are. When controlling by body thermostat sensor only, the unit may therefore be turned off by the thermostat before the lower part of the room reaches the preset temperature. The temperature can be controlled so the lower part of the room where the occupants are doesn't become cold by widening the range in which thermostat sensor in remote control can be used so that suction temperature is higher than the preset temperature.

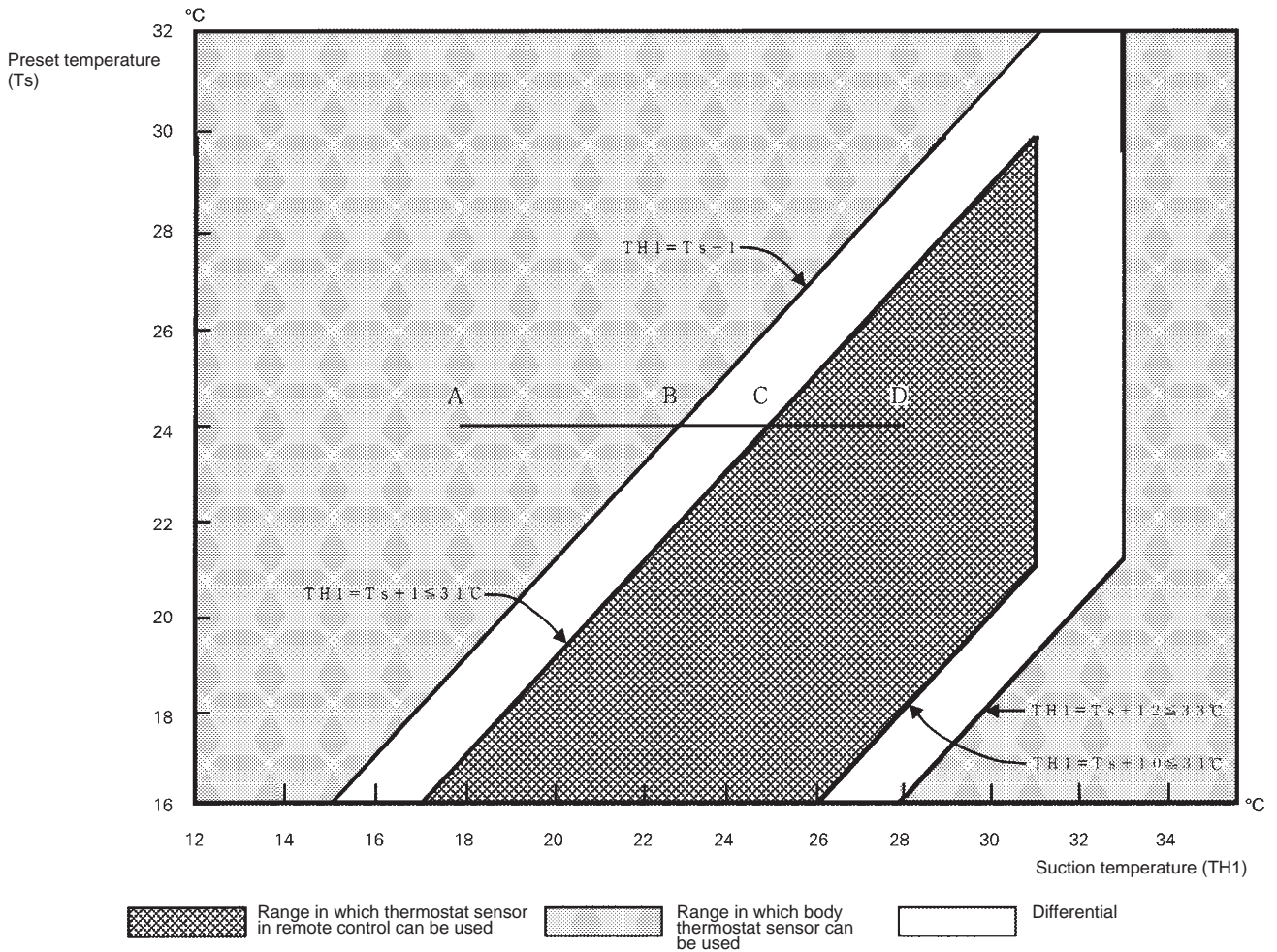

- **Ex: When heating Assuming the preset temperature in the figure above is 24°C, and the suction temperature has changed from 18°C to 28°C (A → D):**
 (This example also assumes there are several other air conditioners, the VRV system is off, and that temperature changes even when the thermostat sensor is off.)
 Body thermostat sensor is used for temperatures from 18°C to 25°C (A → C).
 Remote control thermostat sensor is used for temperatures from 25°C to 28°C (C → D).
- And, assuming suction temperature has changed from 28°C to 18°C (D → A):**
 Remote control thermostat sensor is used for temperatures from 28°C to 23°C (D → B).
 Body thermostat sensor is used for temperatures from 23°C to 18°C (B → A).

6.2.2 Thermostat Control while in Normal Operation

VRV multi systems are set at factory to thermostat control mode using the remote control. While in normal thermostat differential control mode (i.e., factory set mode), the thermostat turns OFF when the system reaches a temperature of -1°C from the set temperature while in cooling operation or of $+1^{\circ}\text{C}$ from that while in heating operation.

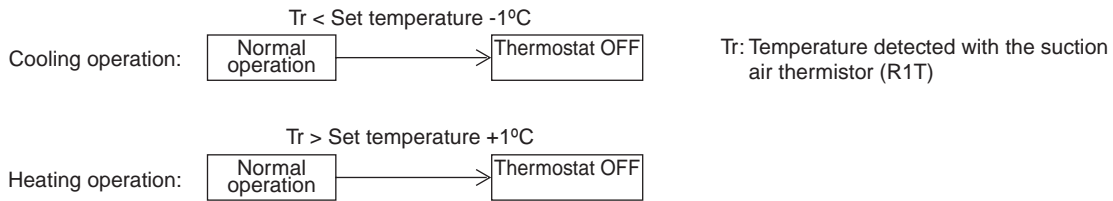

While in a single remote control group control, the body thermostat is only used for this control. Furthermore, while in heating operation, cassette-mounted indoor units conduct the thermostat control by a value compensated by -2°C for the value detected with the body thermostat. (Through field settings, the thermostat differential setting can be changed from 1°C to 0.5°C . For details on the changing procedure, refer to information on page onward.)

6.2.3 Thermostat Control in Dry Operation

While in dry operation, the thermostat control is conducted according to a suction temperature at the time of starting the dry operation.

Assuming that the suction air temperature at the time of starting the dry operation is T_{ro} and the suction air temperature in operation is T_r ,

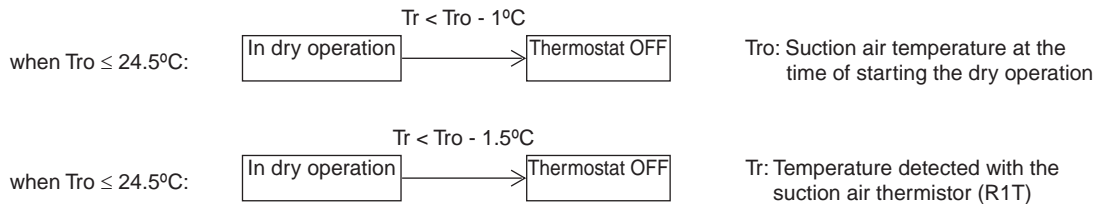

Furthermore, while in dry operation mode, fans operate at L flow rate, stops for a period of six minutes while the thermostat is OFF, and then return to operation at L flow rate. (This control is used to prevent a rise in indoor temperature while in thermostat OFF mode.)

6.2.4 Thermostat Control with Operation Mode Set to "AUTO"

When the operation mode is set to "AUTO" on the remote control, the system will conduct the temperature control shown below.

Furthermore, setting changes of the differential value (D°C) can be made according to information in the "Field settings with remote control (p. 172 and later)" section.

Mode No.	Setting switch No.	Contents of setting	Setting position No.							
			01	02	03	04	05	06	07	08
12	4	Differential value while in "AUTO" operation mode	0°C	1°C	2°C	3°C	4°C	5°C	6°C	7°C

01: Factory setting

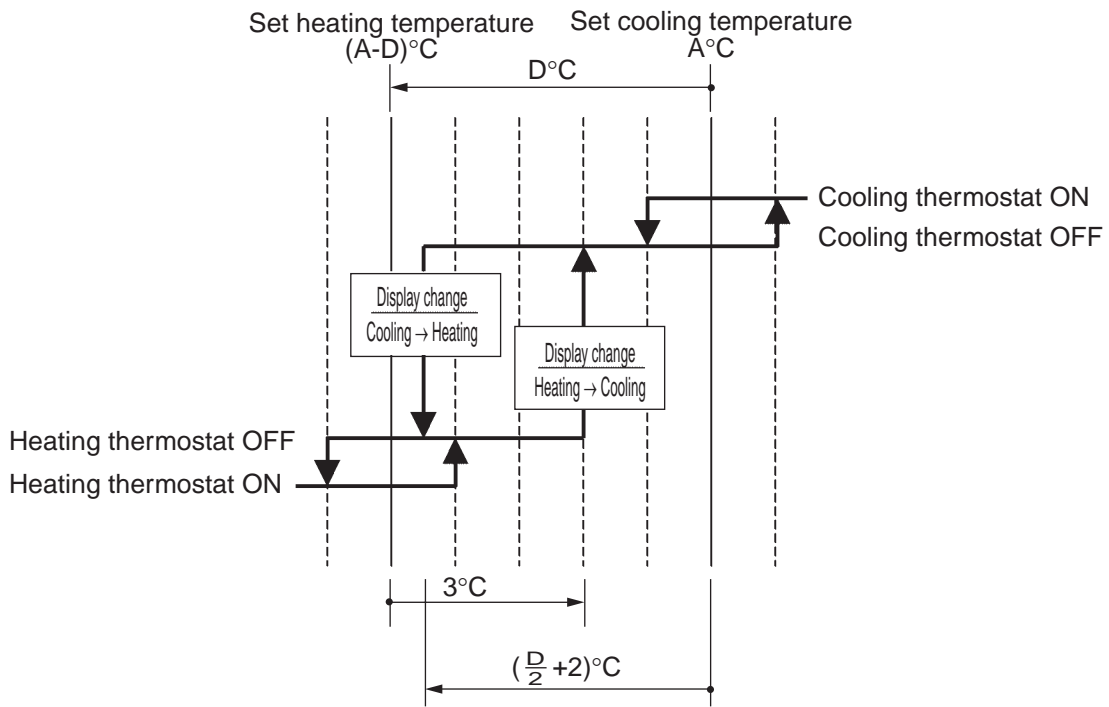

(Ex.) When automatic cooling temperature is set to 27°C:

Differential value :0°C

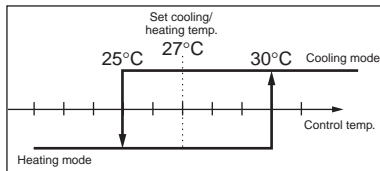

Differential value set to 4°C

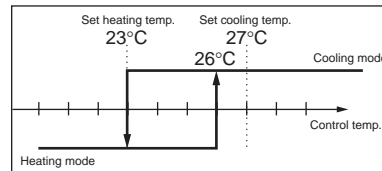

Differential value set to 1°C

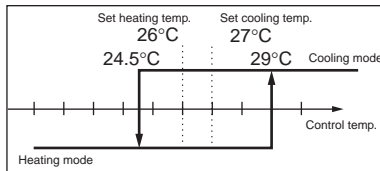

Differential value set to 5°C

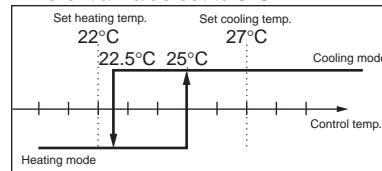

Differential value set to 2°C

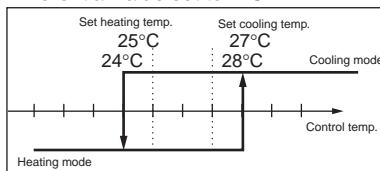

Differential value set to 6°C

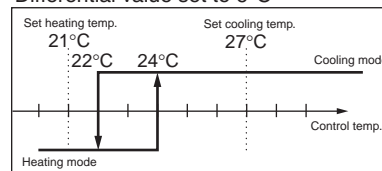

Differential value set to 3°C

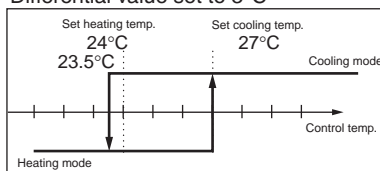

Differential value set to 7°C

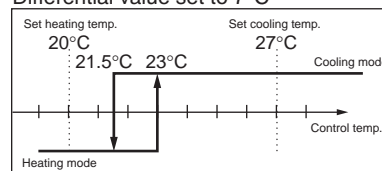

6.3 Drain Pump Control

1. The drain pump is controlled by the ON/OFF buttons (4 button (1) - (4) given in the figure below).

6.3.1 When the Float Switch is Tripped while the Cooling Thermostat is ON:

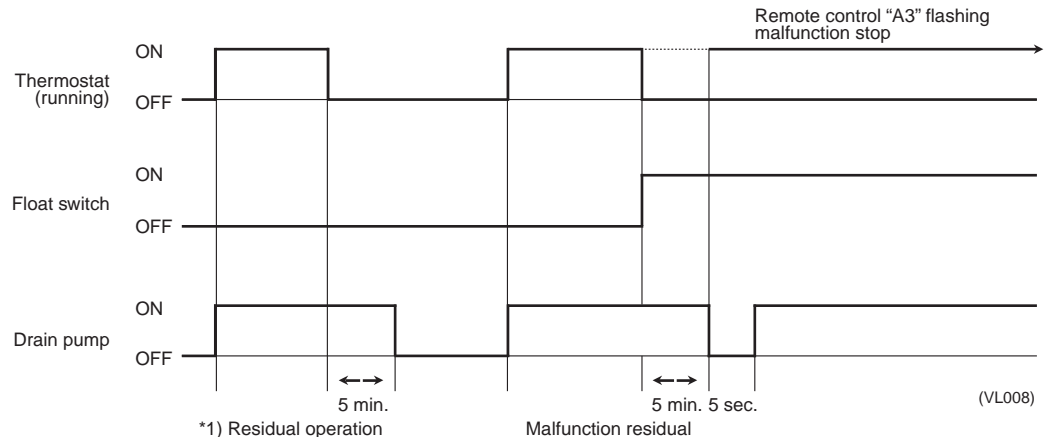

* 1. The objective of residual operation is to completely drain any moisture adhering to the fin of the indoor unit heat exchanger when the thermostat goes off during cooling operation.

6.3.2 When the Float Switch is Tripped while the Cooling Thermostat is OFF :

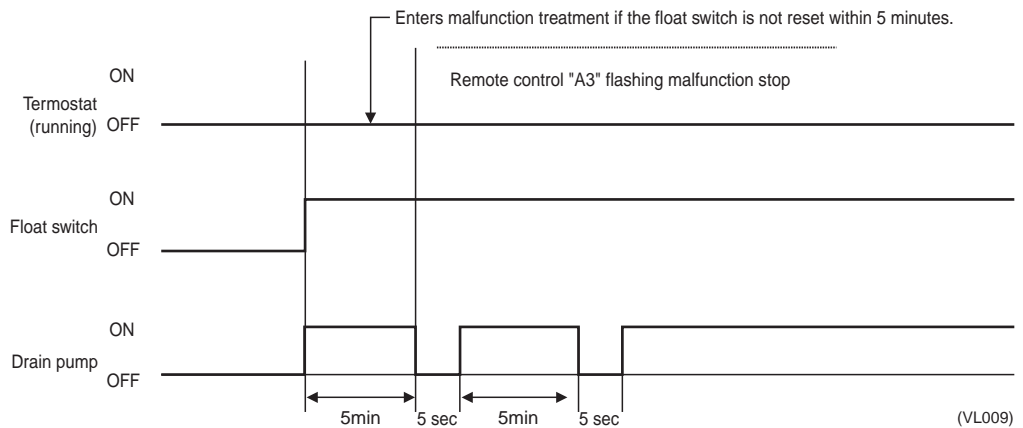

6.3.3 When the Float Switch is Tripped During Heating Operation:

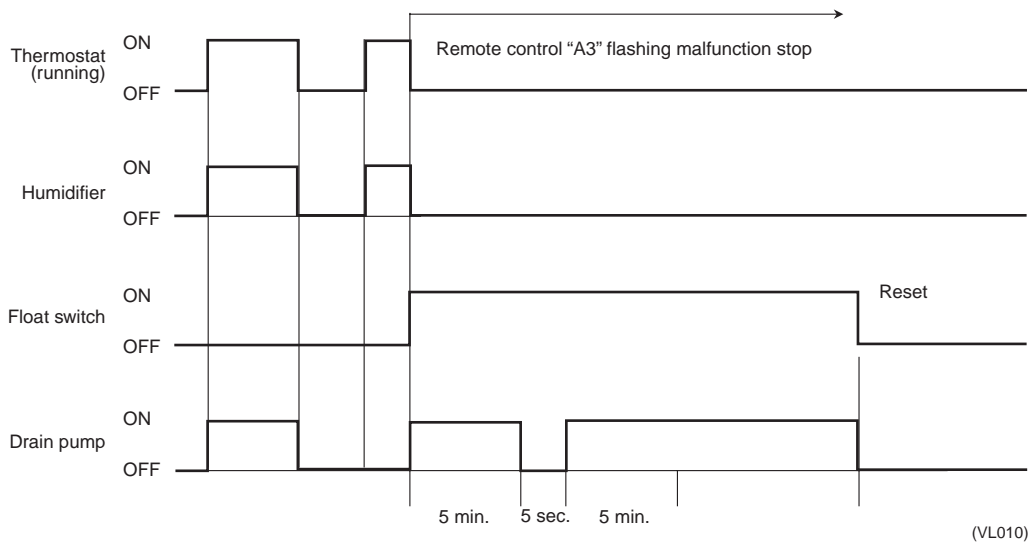

During heating operation, if the float switch is not reset even after the 5 minutes operation, 5 seconds stop, 5 minutes operation cycle ends, operation continues until the switch is reset.

6.3.4 When the Float Switch is Tripped and "AF" is Displayed on the Remote Control:

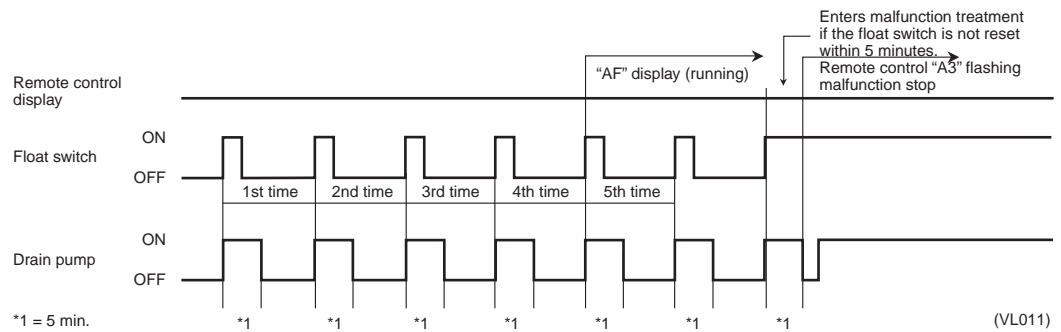

Note: If the float switch is tripped five times in succession, a drain malfunction is determined to have occurred. "AF" is then displayed as operation continues.

6.4 Control of Electronic Expansion Valve

Electronic expansion valves in indoor units have the functions of conducting superheated degree control in cooling operation and subcooled degree control in heating operation. However, if the indoor units receive any control command such as a protection control command or a special control command from the outdoor unit, the units will give a priority to the control command.

- Superheated degree control in cooling operation

This function is used to adjust the opening of the electronic expansion valve so that superheated degree (SH), which is calculated from the detection temperature (T_g) of the gas pipe thermistor (R3T) and the detection temperature (T_1) of the liquid temperature thermistor (R2T) of the indoor unit, will come close to a target superheated degree (SHS).

At that time, correction to the superheated degree is made according to the differences (ΔT) between set temperature and suction air thermistor temperature.

$$SH = T_g - T_1$$

SH:Evaporator outlet superheated degree (°C)

T_g :Indoor unit gas pipe temperature (R3T)

T_1 :Indoor unit liquid pipe temperature (R2T)

SHS (Target SH value)

SHS:Target superheated degree

- Normally 5°C.
- As ΔT (Remote control set temp. - Suction air temp.) becomes larger, SHS becomes lower.
- As ΔT (Remote control set temp. - Suction air temp.) becomes smaller, SHS becomes higher.

- Sub cooled degree control in heating operation

This function is used to adjust the opening of the electronic expansion valve so that the high-pressure equivalent saturated temperature (T_c), which is converted from the detected pressure of the high pressure sensor in the outdoor unit, and the subcooled degree (SC), which is calculated from the detected temperature (T_1) of the liquid temperature thermistor (R2T) in the indoor unit, will come close to the target subcooled degree (SCS).

At that time, corrections to the subcooled degree are made according to differences (ΔT) between set temperature and suction air thermistor temperatures.

$$SC = T_c - T_1$$

SC:Condenser outlet subcooled degree (°C)

T_c :High pressure equivalent saturated temperature detected by the high pressure sensor (S1NPH)

T_1 :Indoor unit liquid pipe temperature (R2T)

SCS (Target SC value)

SCS:Target supercooled degree

- Normally 5°C.
- As ΔT (Remote control set temp. - Suction air temp.) becomes larger, SCS becomes lower.
- As ΔT (Remote control set temp. - Suction air temp.) becomes lower, SCS becomes larger.

6.5 Freeze Prevention

Freeze Prevention by Off Cycle (Indoor Unit)

When the temperature detected by liquid pipe temperature thermistor (R2T) of the indoor unit heat exchanger drops too low, the unit enters freeze prevention operation in accordance with the following conditions, and is also set in accordance with the conditions given below.

When freeze prevention is activated, the electronic expansion valve is closed, the drain pump turns ON and the fan tap is fixed to L air flow. When the following conditions for stopping are satisfied, it returns.

Conditions for starting freeze prevention: Temperature is -1°C or less for total of 40 min., or temperature is -5°C or less for total of 10 min.

Conditions for stopping freeze prevention: Temperature is $+7^{\circ}\text{C}$ or more for 10 min. continuously

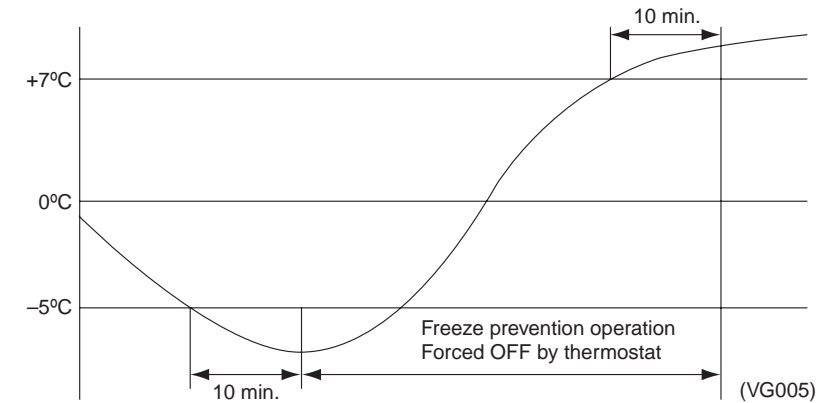

OR

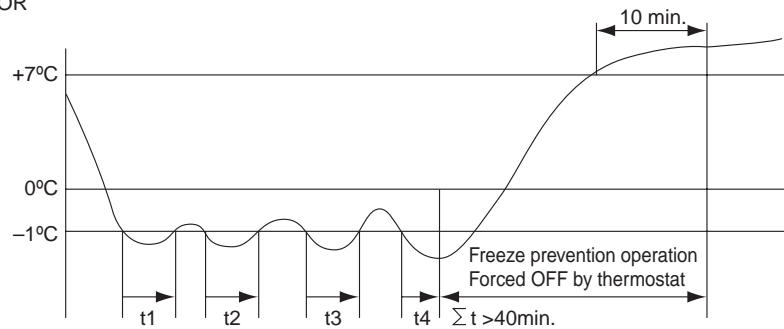

[Conditions for starting when air flow direction is two-way or three-way]

Conditions for starting: Temperature is 1°C or less for a total of 15 minutes or 0°C or less for 1 minute continuously.

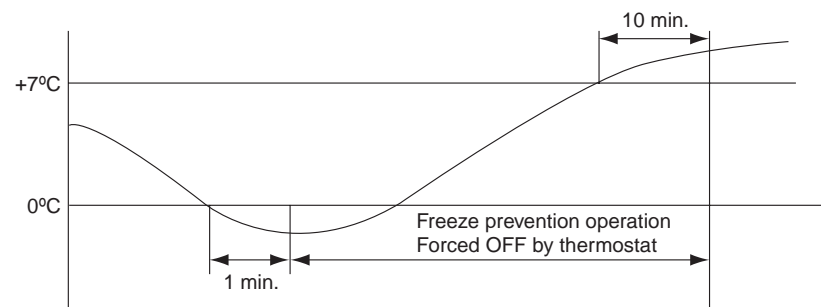

OR

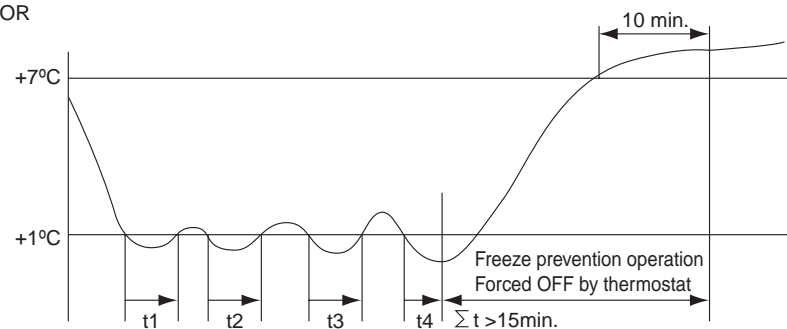

6.6 Heater Control (Optional PC Board KRP1B...is required.)

The heater control is conducted in the following manner.

[Normal control]

While in heating operation, the heater control (ON/OFF) is conducted as shown on the right.

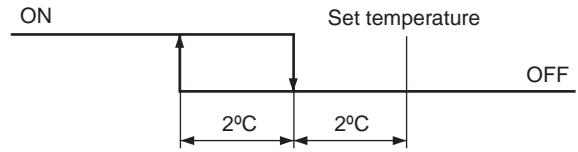

[Overload control]

When the system is overloaded in heating operation, the heater will be turned OFF in the following two manners.

- (1) The heater control (ON/OFF) is conducted through the liquid pipe temperature (R2T) of the indoor unit.
- (2) The heater control (ON/OFF) is conducted by converting the heater temperature into the condensing pressure equivalent saturated temperature (Tc) according to the temperature detection through the high pressure sensor (SINPH) of the outdoor unit.

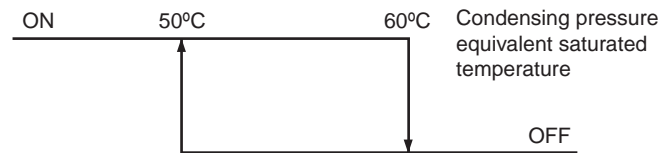
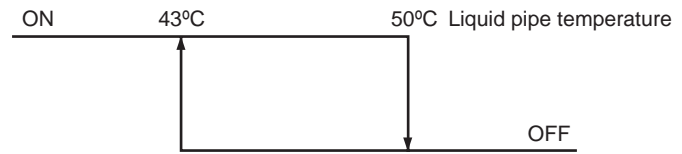

[Fan residual operation]

While the heater turns OFF, in order to prevent the activation of the thermal protector, the fan conducts residual operation for a given period of time after the heater turns OFF. (This operation is conducted regardless of with or without heater equipped.)

Residual operation time = 100 seconds on ceiling suspended type or 60 seconds on other types

6.7 List of Swing Flap Operations

Swing flaps operate as shown in table below.

			Fan	Flap		
				FXFQ	FXCQ FXHQ FXKQ	FXAQ
Heating	Hot start from defrosting operation	Swing	OFF	Horizontal	Horizontal	Horizontal
		Wind direction set	OFF	Horizontal	Horizontal	Horizontal
	Defrosting operation	Swing	OFF	Horizontal	Horizontal	Horizontal
		Wind direction set	OFF	Horizontal	Horizontal	Horizontal
	Thermostat OFF	Swing	LL	Horizontal	Horizontal	Horizontal
		Wind direction set	LL	Horizontal	Horizontal	Horizontal
	Hot start from thermostat OFF mode (for prevention of cold air)	Swing	LL	Horizontal	Horizontal	Horizontal
		Wind direction set	LL	Horizontal	Horizontal	Horizontal
	Stop	Swing	OFF	Horizontal	Horizontal	Totally closed
		Wind direction set	OFF	Horizontal	Horizontal	Totally closed
Cooling	Thermostat ON in dry operation using micro computer	Swing	L* ¹	Swing	Swing	Swing
		Wind direction set	L* ¹	Set	Set	Set
	Thermostat OFF in dry operation using micro computer	Swing	OFF or L	Swing	Swing	Swing
		Wind direction set		Set	Set	Set
	Thermostat OFF in cooling	Swing	Set	Swing	Swing	Swing
		Wind direction set	Set	Set	Set	Set
	Stop	Swing	OFF	Horizontal	Horizontal	Totally closed
		Wind direction set	OFF	Set	Horizontal	Totally closed
	Micro computer control (including cooling operation)	Swing	L	Swing	Swing	Swing
		Wind direction set	L	Set	Set	Set

*1. L or LL only on FXFQ models

6.8 Hot Start Control (In Heating Operation Only)

At startup with thermostat ON or after the completion of defrosting in heating operation, the indoor unit fan is controlled to prevent cold air from blasting out and ensure startup capacity.

[Detail of operation]

When either the **start condition 1** or the **start condition 2** is established, the operations shown below will be conducted.

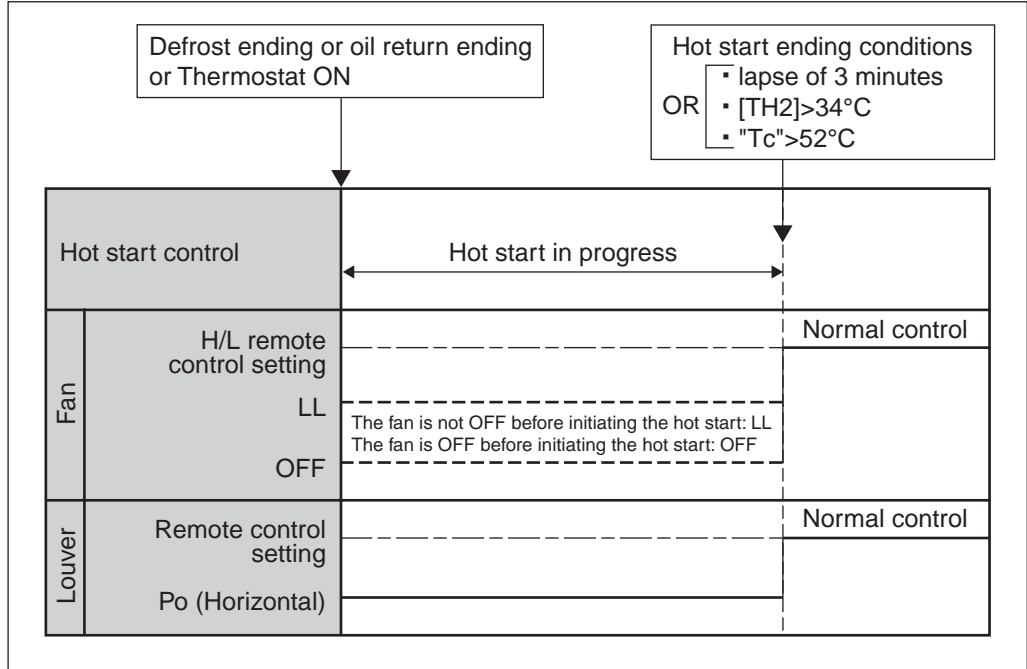

TH₂: Temperature (°C) detected with the gas thermistor

TC : High pressure equivalent saturated temperature

6.9 Louver Control for Preventing Ceiling Dirt

We have added a control feature that allows you to select the range of in which air direction can be adjusted in order to prevent the ceiling surrounding the air discharge outlet of ceiling mounted cassette type units from being soiled. (This feature is available on double flow, multi-flow and corner types.)

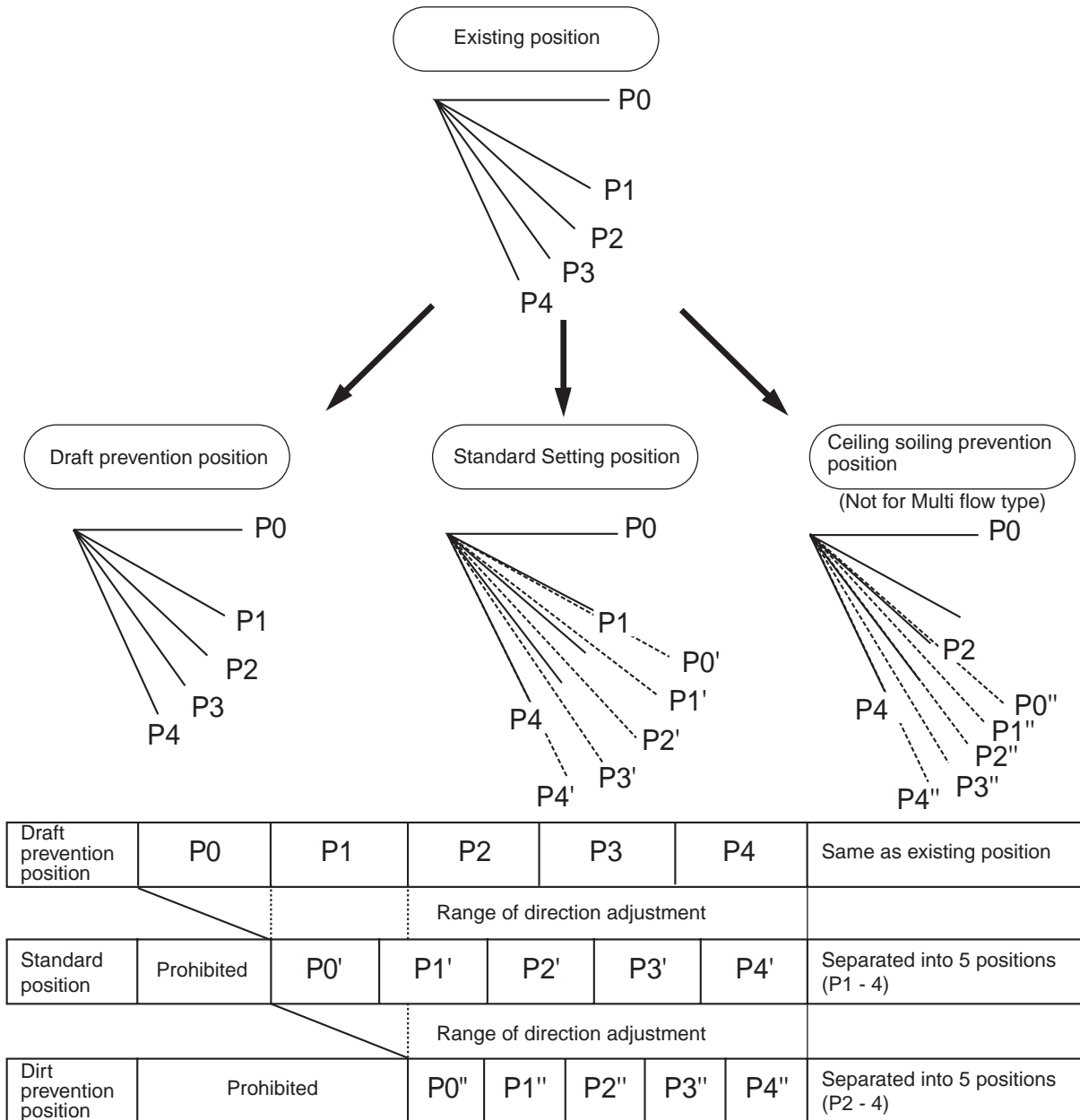

The factory set position is standard position.

(VL012)

Part 5

Test Operation

1. Test Operation	156
1.1 Installation Process	156
1.2 Procedure and Outline	157
1.3 Operation when Power is Turned On	200
2. Outdoor Unit PC Board Layout	201
3. Field Setting	202
3.1 Field Setting from Remote Control	202
3.2 Field Setting from Outdoor Unit.....	215

1. Test Operation

1.1 Installation Process

Below Figure shows the installation process. Install in the order of the steps shown.

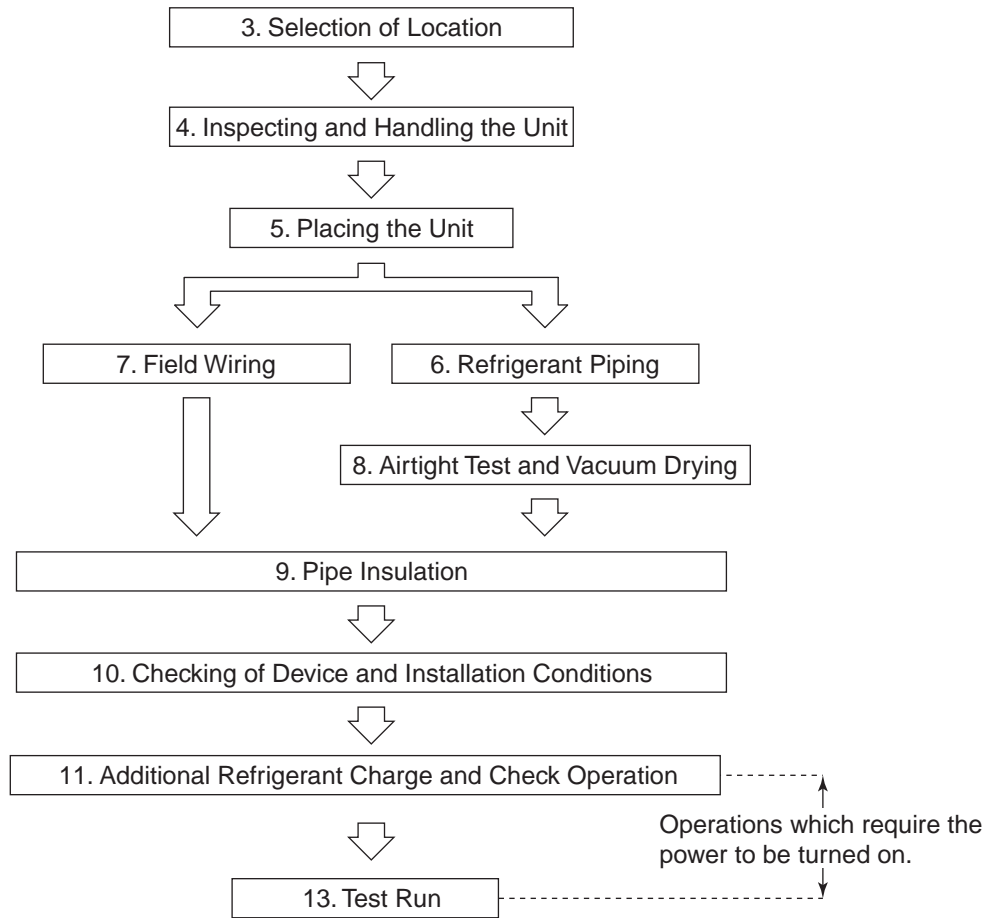

1.2 Procedure and Outline

Follow the following procedure to conduct the initial test operation after installation.

1.2.1 Check Work Prior to Turn Power Supply On

Check the below items.

- Power wiring
- Control transmission wiring between units
- Earth wire



- Is the wiring performed as specified?
- Is the designated wire used?
- Is the wiring screw of wiring not loose?
- Is the grounding work completed?
- Is the insulation of the main power supply circuit deteriorated?
Use a 500V megger tester to measure the insulation. (*1)
 - Do not use a megger tester for other circuits than 200V (or 240V) circuit.

*1: Measure to be taken against decreased insulation resistance in the compressor

If the compressor is left to stand for an extended period of time after the refrigerant charge with the stop valve open and the power supply OFF, the refrigerant may be mixed in the compressor, thus decreasing the insulation resistance.

Heat the compressor as shown on the right and then recheck the insulation.

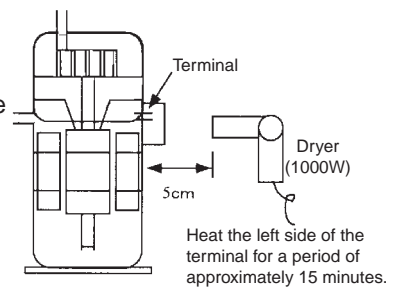

Check on refrigerant piping / insulation materials



- Is the pipe size proper?
- Are the design pressures for the liquid pipe, suction pipe, dual pressure gas pipe, and pressure equalizer pipe (in case of multi units) all not less than 4.0 MPa?
- Is the pipe insulation material installed securely?
Liquid, suction and high & low pressure gas pipe need to be insulated. (Otherwise causes water leak.)

Check airtight test and vacuum drying.



- Have the airtight test and the vacuum drying been conducted according to the procedure in the Installation Manual?

Check on amount of refrigerant charge



- Is a proper quantity of refrigerant charged?
The following method is available for additional charging of refrigerant.
(1) Calculate additional refrigerant quantity.

- Calculate a necessary additional refrigerant charging amount according to the procedure for calculation shown below.
- * Procedure for calculating additional refrigerant charging amount (Unit: 0.1 kg)

Correction amount with indoor unit

System name	Correction amount
Model REYQ8-16P8Y1B	3.6 kg
Model REYQ18-20P8Y1B	1.0kg
Model REYQ22-24P8Y1B	1.5kg
Model REYQ26P8Y1B	2.0kg
+ Model REYQ28-30P8Y1B	2.5kg
Model REYQ32-40P8Y1B	3.0kg
Model REYQ42P8Y1B	3.5kg
Model REYQ44-46P8Y1B	4.0kg
Model REYQ48P8Y1B	4.5kg

Correction amount with a total capacity of indoor units

Ratio of total capacity of the connected indoor units to the rated capacity of the outdoor unit (A)	Correction amount	
	Model REYQ18 - 32P8Y1B	Model REYQ34 - 48P8Y1B
100% < A ≤ 120%	0.5kg	
120% < A ≤ 130%	0.5kg	1.0kg

- If there is a refrigerant shortage, charge a liquid refrigerant through the stop valve service port with the stop valves of liquid and those of gas closes after the completion of vacuum drying.
- If the refrigerant charging is still insufficient, "turn ON the power supply" following the information on the page 162 ~.

- Has the additional refrigerant charging amount been recorded on the "Precautions for servicing" label?

Check the stop valves for conditions.

- Check to be sure the stop valves are under the following conditions.

Liquid-pipe stop valve	Equalizing pipe stop valve	Dual pressure gas pipe stop valve	Suction pipe stop valve
Open	Open	Open	Open

1.2.2 Turn Power On

Turn outdoor unit and indoor unit power on.



Check the LED display of the outdoor unit PC board.



Make field settings with outdoor unit PC board.



<REYQ8~16P8Y1B>

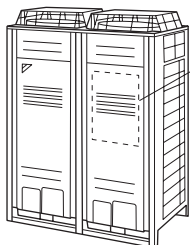

Inside a switch box "A1P" PC board

<REMQ8~12P8Y1B>

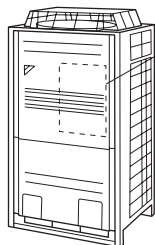

Inside a switch box "A1P" PC board

<REMQ14, 16P8Y1B>



Inside a switch box "A1P" PC board

* Another switch box is provided on the front left side of the unit, but it requires no field settings.

Conduct check operations.



Check for normal operation.

○ Be sure to turn the power on 6 hours before starting operation to protect compressors. (to power on clankcase heater)

○ Check to be sure the transmission is normal. The transmission is normal if the LEDs display conditions as shown in table below.

LED display ☼ ON ● OFF ⚡ Blinking

LED display (Default status before delivery)	Micro-computer operation monitor	MODE	TEST	COOL / HEAT select			Low noise	Demand	Multi
				IND	MASTER	SLAVE			
				HAP	H1P	H2P			
One outdoor unit installed	⚡	●	●	☼	●	●	●	●	●
When multiple outdoor unit installed (*)	Master	⚡	●	●	☼	●	●	●	☼
	Slave 1	⚡	●	●	●	●	●	●	⚡
	Slave 2	⚡	●	●	●	●	●	●	●

(*) The master unit is the outdoor unit to which the transmission wiring for the indoor units is conncted. The other outdoor units are slave units.

○ Make field settings if needed. (For the setting procedure, refer to information in "3.2. Field Setting from Outdoor Unit" on page 215 onward.) For the outdoor-multi system, make field settings with the master unit. (Field settings made with the slave unit will be all invalid.)

The check operations shown below will be automatically initiated.

- Check for erroneous wirings
- Check for failure to open stop valves
- Check for excessive refrigerant refilling
- Automatic judgment of piping length

○ Before starting the normal operation after the completion of check operations, make sure indoor and outdoor units normally operate.

1.2.3 Air Tight Test and Vacuum Drying

Note:

- Always use nitrogen gas for the airtightness test.
- Absolutely do not open the shutoff valve until the main power circuit insulation measurement has been completed. (measuring after the shutoff valve is opened will cause the insulation value to drop.)

<Needed tools>

Gauge manifold Charge hose valve	<ul style="list-style-type: none"> • To prevent entry of any impurities and insure sufficient pressure resistance, always use the special tools dedicated for R-410A. • Use charge hose that have pushing stick for connecting to service port of shutoff valves or refrigerant charge port.
Vacuum pump	<ul style="list-style-type: none"> • The vacuum pump for vacuum drying should be able to lower the pressure to -100.7kPa (5 Torr -755mm Hg). • Take care the pump oil never flow backward into the refrigerant pipe during the pump stops.

<The system for air tight test and vacuum drying>

- Referring to next figure, connect an nitrogen tank, refrigerant tank, and a vacuum pump to the outdoor unit.

The refrigerant tank and the charge hose connection to refrigerant charge port or the valve A in next figure are needed in “1.2.5 Additional Refrigerant Charge and Check Operation”.

REYQ8~16P8Y1

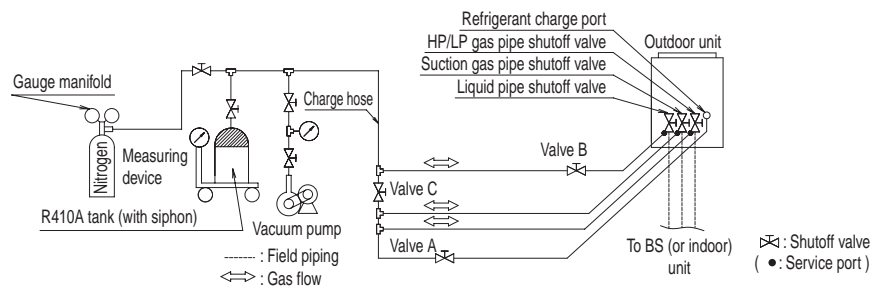

REYQ18~48P8Y1

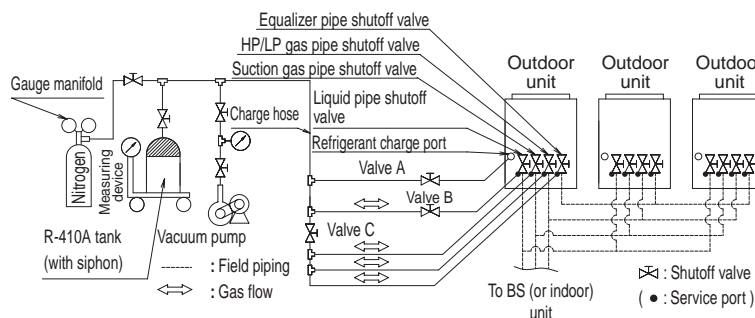

Note:

- The airtightness test and vacuum drying should be done using the service ports of equalizer pipe, HP/LP gas pipe, suction gas pipe and liquid pipe shutoff valve.
See the [R-410A] Label attached to the front plate of the outdoor unit for details on the location of the service port (see figure at right)
- See [Shutoff valve operation procedure] in “1.2.5.1 Before Working” for details on handling the shutoff valve.
- The refrigerant charge port is connected to unit pipe.
When shipped, the unit contains the refrigerant, so use caution when attaching the charge hose.

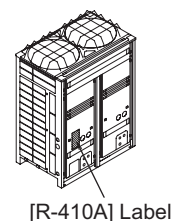

<Air tight test>

Pressurize the liquid pipe, suction gas pipe, HP/LP gas pipe and equalizer pipe from the service ports of each shutoff valve to 4.0MPa (40bar) (do not pressurize more than 4.0MPa (40bar)). If the pressure does not drop within 24 hours, the system passes the test.

If there is a pressure drop, check for leaks, make repairs and perform the airtight test again.

<Vacuum drying>

Evacuate the system from the liquid and gas pipes by using a vacuum pump for more than 2 hours and bring the system to -100.7kPa or less. After keeping the system under that condition for more than 1 hour, check if the vacuum gauge rises or not. If it rises, the system may either contain moisture inside or have leaks.

Note:

■ **If moisture might enter the piping, follow below.**

(i.e., if doing work during the rainy season, if the actual work takes long enough that condensation may form on the inside of the pipes, if rain might enter the pipes during work, etc.)

1. After performing the vacuum drying for two hours, pressurize to 0.05 MPa (i.e., vacuum breakdown) with nitrogen gas, then depressurize down to -100.7 kPa for an hour using the vacuum pump (vacuum drying).
2. If the pressure does not reach -100.7 kPa even after depressurizing for at least two hours, repeat the vacuum breakdown - vacuum drying process.

After vacuum drying, maintain the vacuum for an hour and make sure the pressure does not rise by monitoring with a vacuum gauge.

1.2.4 Pipe Insulation

- Insulation of pipes should be done after performing “1.2.3. Air Tight Test and Vacuum Drying”.
- Always insulate the liquid piping, the HP/LP gas piping, the gas piping, the equalizer pipe (between the outdoor units for the outdoor multi system) and these pipe connections. Failing to insulate the pipes may cause leaking or burns. Especially, be sure to insulate the HP/LP gas piping as withstanding as the suction pipe because the suction gas follows in the HP/LP gas piping when the system is whole cooling mode. And be sure to use the insulation which can withstand such temperatures of 120°C or more for the HP/LP gas piping, the equalizer pipe and the gas piping because the HP/LP gas follows in these pipings.
- Reinforce the insulation on the refrigerant piping according to the installation environment. Condensation might form on the surface of the insulation. Refer to the below.
 - Ambient temperature : 30°C , humidity : 75% to 80% RH : min. thickness : 15mm.
 - If the ambient temperature exceeds 30°C and the humidity 80% RH, then the min. thickness is 20mm.

See the Engineering data book for detail.
- If there is a possibility that condensation on the shutoff valve might drip down into the indoor unit through gaps in the insulation and piping because the outdoor unit is located higher than the indoor unit, etc., this must be prevented by caulking the connections, etc. **(Refer to next figure)**
- The piping lead-out hole lid should be attached after opening a knock hole. **(Refer to next figure)**
- If small animals and the like might enter the unit through the piping lead-out hole, close the hole with blocking material (procured on site) after completion of “1.2.5 Additional Refrigerant Charge and Check Operation”. **(Refer to next figure)**

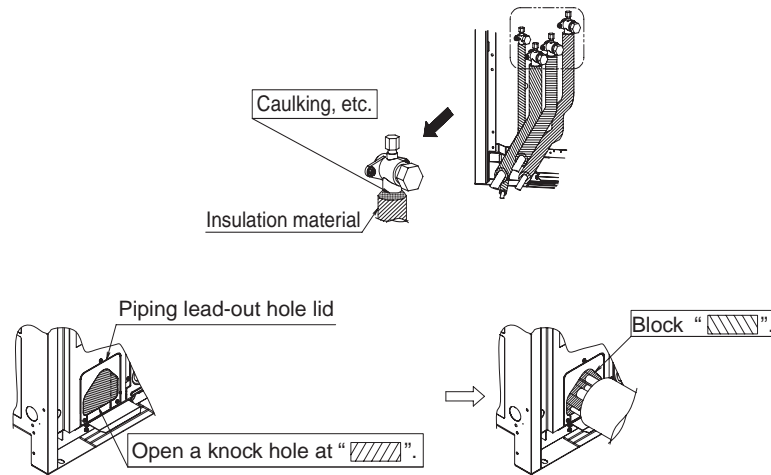

Note:

- After knocking out the holes, we recommend you remove burrs in the knock holes (**See above figure**) and paint the edges and areas around the edges using the repair paint.

1.2.5 Charging Refrigerant - REYQ8~16P8Y1B

The outdoor unit is factory charged, but depending on the length of the piping when installed, the outdoor unit may require additional charging.

For charging the additional refrigerant follow the procedure as described in this chapter.



Refrigerant cannot be charged until all field wiring and field piping has been completed. Refrigerant may only be charged after performing the leak test and the vacuum drying.

1.2.5.1 Important information regarding the refrigerant used

This product contains fluorinated greenhouse gases covered by the Kyoto Protocol. Do not vent gases into the atmosphere.

Refrigerant type : R-410A

GWP⁽¹⁾ value : 1975

(1) GWP = global warming potential

Please fill in with indelible ink,

- ① the factory refrigerant charge of the product,
- ② the additional refrigerant amount charged in the field and
- ① + ② the total refrigerant charge

on the refrigerant charge label supplied with the product.

The filled out label must be adhered in the proximity of the product charging port (e.g. onto the inside of the service cover).

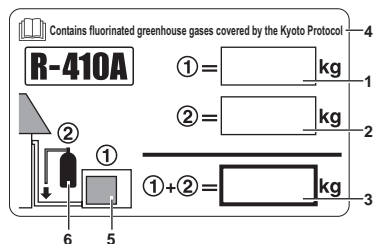

- 1 factory refrigerant charge of the product: see unit name plate
- 2 additional refrigerant amount charged in the field
- 3 total refrigerant charge
- 4 contains fluorinated greenhouse gases covered by the Kyoto Protocol
- 5 outdoor unit
- 6 refrigerant cylinder and manifold for charging

1.2.5.2 Precautions when adding R-410A

Be sure to charge the specified amount of refrigerant in liquid state.

Since this refrigerant is a mixed refrigerant, adding it in gas form may cause the refrigerant composition to change, preventing normal operation.

- Before charging, check whether the refrigerant cylinder is equipped with a siphon tube or not.

Charge the liquid refrigerant with the cylinder in upright position.

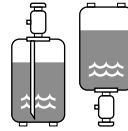

Charge the liquid refrigerant with the cylinder in up-side-down position.

- Be sure to use tools exclusively for R-410A to ensure required pressure resistance and to prevent foreign materials from mixing into the system.



Charging with an unsuitable substance may cause explosions and accidents, so always make sure that the appropriate refrigerant (R-410A) is charged. Refrigerant containers must be opened slowly.

1.2.5.3 Stop valve operation procedure

Size of stop valve

The sizes of the stop valves connected to the system are as listed in the table below.

Type of stop valve	8 Hp	10 Hp	12 Hp	14 Hp	16 Hp
Liquid pipe		$\phi 9.5^{(a)}$			$\phi 12.7$
Suction gas pipe			$\phi 25.4^{(b)}$		
High pressure/low pressure gas pipe			$\phi 19.1^{(c)}$		

(a) The 12 Hp model supports field piping of $\phi 12.7$ on the accessory pipe supplied with the unit.

(b) The 8 Hp model supports field piping of $\phi 19.1$ on the accessory pipe supplied with the unit.

The 10 Hp model supports field piping of $\phi 22.2$ on the accessory pipe supplied with the unit.

The 12~16 Hp models support field piping of $\phi 28.6$ on the accessory pipe supplied with the unit.

(c) The 8 Hp model supports field piping of $\phi 15.9$ on the accessory pipe supplied with the unit.

The 14 and 16 Hp models support field piping of $\phi 22.2$ on the accessory pipe supplied with the unit.



- Do not open the stop valve until all piping and electrical steps of “1.2.4 Pipe Insulation” on page 161 are completed. If the stop valve is left open without turning on the power, it may cause refrigerant to build up in the compressor, leading to insulation degradation.
- Always use a charge hose for service port connection.
- After tightening the cap, check that no refrigerant leaks are present.

Opening stop valve (See figure 19)

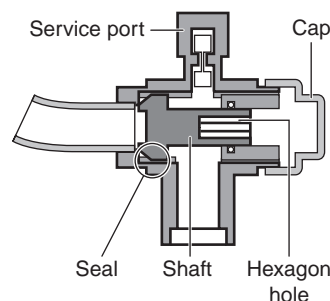

figure 19

1. Remove the cap and turn the valve counterclockwise with the hexagon wrench.
2. Turn it until the shaft stops.



Do not apply excessive force to the stop valve. Doing so may break the valve body.

3. Make sure to tighten the cap securely. Refer to the table below.

Stop valve size	Tightening torque N•m (Turn clockwise to close)			
	Shaft		Cap (valve lid)	Service port
	Valve body	Hexagonal wrench		
φ9.5	5.4~6.6	4 mm	13.5~16.5	11.5~13.9
φ12.7	8.1~9.9		18.0~22.0	
φ22.2	27.0~33.0	8 mm	22.5~27.5	
φ25.4				

Closing stop valve (See figure 19)

1. Remove the cap and turn the valve clockwise with the hexagon wrench.
2. Securely tighten the valve until the shaft contacts the main body seal.
3. Make sure to tighten the cap securely.

For the tightening torque, refer to the table above.

1.2.5.4 How to check how many units are connected

It is possible to find out how many indoor units are active and connected by operating the push-button switch on the printed circuit board (A1P) of the working outdoor unit. Make sure that all the indoor units connected to the outdoor unit are active.

Follow the 5-step procedure as explained below.

- The LEDs on the A1P shows the operating status of the outdoor unit and the number of indoor units that are active.

● OFF ☀ ON ⚡ Blinking

- The number of units that are active can be read from the LED display in the "Monitor Mode" procedure below.

Example: in the following procedure there are 22 units active:



Note: Wherever during this procedure, press the **BS1 MODE** button if something becomes unclear. You will return to setting mode 1 (H1P= ● "OFF").

1 Setting mode 1 (default system status)



Press the **BS1 MODE** button to switch from setting mode 1 to monitor mode.

2 Monitor mode

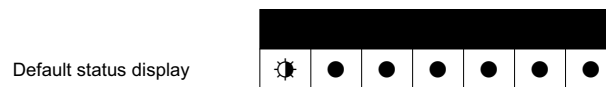

To check the number of indoor units, press the **BS2 SET** button 5 times.

3 Monitor mode



Pressing the **BS3 RETURN** button causes the LED display to show the data on the number of indoor units that are connected.

4 Monitor mode

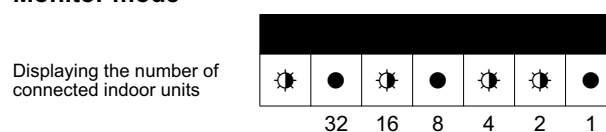

Calculate the number of connected indoor units by adding the values of all (H2P~H7P) blinking (☀) LEDs together.

In this example: 16+4+2=22 units

Press the **BS1 MODE** button to return to step 1, setting mode 1 (H1P= ● "OFF").

1.2.5.5 Additional refrigerant charge



Adding refrigerant using the automatic refrigerant charging function is recommended.

Follow the procedures below.



- When charging a system, charging over the permissible quantity can cause liquid hammer.
- Always use protective gloves and protect your eyes when charging refrigerant.
- When the refrigerant charging procedure is done or when pausing, close the valve of the refrigerant tank immediately.
 - The refrigerant charge port has a electric expansion valve and will be closed at the end of the refrigerant charging. However, the valve will be opened when operating the unit after refrigerant charging.
 - If the tank is left with the valve open, the amount of refrigerant which is properly charged may get off point. More refrigerant may be charged by any remaining pressure after the unit has stopped.



Electric shock warning

- Close the electric component box lid before turning on the main power.
 - Perform the settings on the circuit board (A1P) of the outdoor unit and check the LED display after the power is on via the service lid which is in the lid of the electric component box.
- Operate switches with an insulated stick (such as a ball-point pen) to avoid touching the life parts.
- Make sure to re-attach the inspection cover into the switch box cover after the job is finished.



- If the power of some units is turned off, the charging procedure can not be finished properly.
- Make sure to turn ON the power 6 hours before starting the operation. This is necessary to warm the crankcase by the electric heater.
- If operation is performed within 12 minutes after the indoor units, BS units and outdoor unit are turned on, the H2P-LED will be lit and the compressor will not operate.



Note:

- See " 1.2.5.3 Stop valve operation procedure" on page 163 for details on how to handle stop valves.
- The refrigerant charging port is connected to the piping inside the unit. The unit's internal piping is already factory charged with refrigerant, so be careful when connecting the charge hose.
- After adding the refrigerant, do not forget to close the lid of the refrigerant charging port. The tightening torque for the lid is 11.5 to 13.9 N•m.
- In order to ensure uniform refrigerant distribution, it may take the compressor ± 10 minutes to start up after the unit has started operation. This is not a malfunction.

1. Procedure for additional refrigerant charge

The automatic refrigerant charging has limits as described below.

At out of limit, the system can not operate the automatic refrigerant charging.

Outdoor temperature	: 0°C DB~43°C DB
Indoor temperature	: 10°C DB~32°C DB
Total indoor unit capacity	: $\geq 80\%$

Pre-charging

To speed up the process of charging refrigerant for large systems, it is recommended to first manually charge a portion of the refrigerant first before performing automatic charging.

1. Calculate how much refrigerant to be added using the formula explained in the chapter "How to calculate the additional refrigerant to be charged" on page 158.
2. The amount of pre-charging is 10 kg less than the calculated amount.

3. Open valve B (the valves A and C, the liquid pipe, the suction gas pipe and the high pressure/low pressure gas pipe stop valves must be left closed) and charge the refrigerant in liquid form via the liquid pipe stop valve service port. (See figure 23)

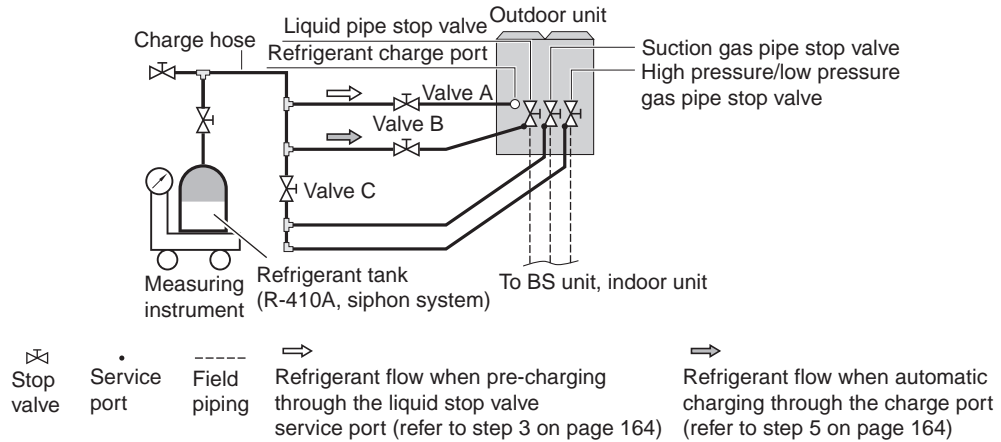

figure 23

4. If the calculated amount of pre-charging is reached, close valve B.



At least the unit should be charged with its original amount of refrigerant (refer to the nameplate on the unit), before starting the automatic charging.



Note:

When the leak detection function is not required, complete charging when using the previous described method (unit is not operating) can be done. If it is not possible to charge the entire quantity through the service port of the liquid pipe stop valve with the unit not operating, refer to " 1.2.5.8.7 Additional refrigerant charging method" on page 180.

5. After pre-charging, perform the refrigerant charge operation as shown below and charge the remaining refrigerant of the additional charging amount through valve A. (See figure 23)



Note:

The refrigerant will be charged with ± 30 kg in 1 hour time at an outdoor temperature of 30°C DB or with ± 12 kg at an outdoor temperature of 0°C DB. During the automatic charging operation, you can force the operation to a halt by pushing the **BS1 MODE** button.

1. Start of automatic charging refrigerant

- Open the liquid pipe, suction gas pipe and high pressure/low pressure gas pipe stop valves and the service port stop valve. (Valves A, B and C must be closed.)
- Close all front panels except the electric component box front panel and turn the power ON.
- Make sure all indoor units are connected, refer to " 1.2.5.4 How to check how many units are connected" on page 164.
- If the H2P LED is not flashing (in 12 minutes time after turning on the power), make sure it is displayed as shown in the "2. Normal system display" on page 169. If the H2P LED is flashing, check the malfunction code on the remote control "3. Remote control malfunction code display" on page 170.



- If you perform the refrigerant charging operation within the refrigerant system with one or more units with power OFF, the refrigerant charging operation can not be accomplished properly. For confirming the number of indoor units with power ON, refer to " 1.2.5.4 How to check how many units are connected" on page 164.

- To energize the crankcase heater, make sure to turn the power ON at least 6 hours before starting operation.
2. Press the **BS1 MODE** button once if the LEDs combination is not as in the figure below.



3. Press the **BS4 TEST** button once.

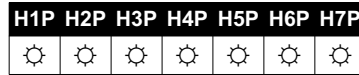

4. Hold the **BS4 TEST** button down for 5 seconds or more.

5. Charging mode judgement

However, if the indoor temperature is 10°C DB or lower, in some cases the unit will charge in heating mode to increase the indoor temperature.

The unit will automatically select the cooling mode or heating mode for charging.



- When charging in cooling mode, the unit will stop operating when the required amount of refrigerant is charged.
- During charging in heating mode, a person must manually close valve A before complete charging is finished. The required amount is the calculated amount (see "6. Example of connection" on page 450), therefore, the weight must be monitored constantly.

<Charging in heating mode >

6. Start up

Wait while the unit is preparing for charging in heating mode.

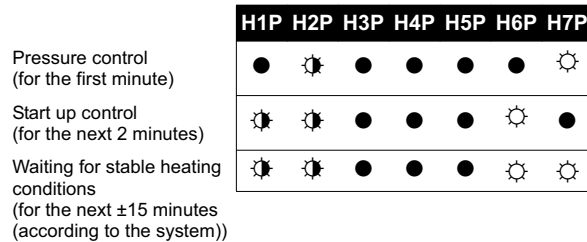

It takes about 2 to 10 minutes for the system to become stable.

In case of a small charging amount, the system will start charging the refrigerant before the system reaches the stable state. It may disturb a correct decision and may cause overcharging.

7. Ready



Press the **BS4 TEST** button once within 5 minutes.

If the **BS4 TEST** button is not pushed within 5 minutes, *P2* will be displayed on the remote control. Refer to "3. Remote control malfunction code display" on page 170.

8. Operation

When the following LED display is shown, open valve A and close the front panel. If the front panel is left open, the system can not operate properly during the refrigerant charging.



When the refrigerant tank is not connected or is left with the valve closed for 30 minutes or more, the outdoor unit will stop operation and the *P2* code will be displayed on the remote control of the indoor unit. Follow the procedure as described in "3. Remote control malfunction code display" on page 170.



* = The state of this LED is not important.



When a malfunction occurs, check the display of the remote control and refer to "3. Remote control malfunction code display" on page 170.

9. Complete

If the calculated amount of refrigerant is reached, close valve A and press the **BS3 RETURN** button once.



Note: Always close valve A and remove the refrigerant tank immediately after finishing the refrigerant charge operation.



Beware of the fan blades when you open the frontpanel. The fan may still rotate for a while after unit operation has stopped.

10. In case leak detection function is required

Press the **BS4 TEST** button once for post-processing with regard to the leak detection function and press the **BS1 MODE** button to confirm that charging is completed. Record the amount that was added on the additional refrigerant charge label provided with the unit and attach it on the back side of the front panel. Perform the procedure " 1.2.5.6 Procedure for inputting the additional refrigerant charge weight into the PC board" as described on page 170.

10. In case leak detection function is not required

Press the **BS1 MODE** button once and the charging is complete. Record the amount that was added on the additional refrigerant charge label provided with the unit and attach it on the back side of the front panel. Perform the procedure " 1.2.5.6 Procedure for inputting the additional refrigerant charge weight into the PC board" as described on page 170.

<Charging in cooling mode>

6. Start up

Wait while the unit is preparing for charging in cooling mode.

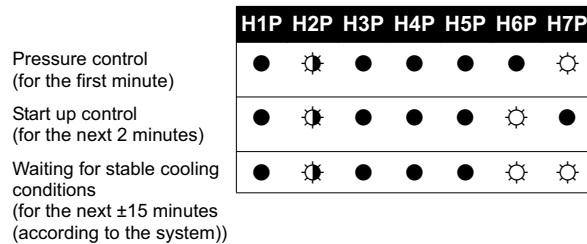

It takes about 2 to 10 minutes for the system to become stable. In case of a small charging amount, the system will start charging the refrigerant before the system reaches the stable state. It may disturb a correct decision and may cause overcharging.

7. Ready



Press the **BS4 TEST** button once within 5 minutes. If the **BS4 TEST** button is not pushed within 5 minutes, **P2** will be displayed on the remote control. Refer to "3. Remote control malfunction code display" on page 170.

8. Operation

When the following LED display is shown, open valve A and close the front panel. If the front panel is left open, the system can not operate properly during the refrigerant charging.



When the refrigerant tank is not connected or is left with the valve closed for 30 minutes or more, the outdoor unit will stop operation and the **P2** code will be displayed on the remote control of the indoor unit. Follow the procedure as described in "3. Remote control malfunction code display" on page 170.



* = The state of this LED is not important.



When a malfunction occurs, check the display of the remote control and refer to "3. Remote control malfunction code display" on page 170.

9. Complete



The display on the remote control shows a flashing *PE* code for signalling that automatic charging will be finished in about 10 minutes.

When the unit stops operating, close valve A immediately and check the LEDs and check if the *PS* code is displayed on the remote control.



Note: Always close valve A and remove the refrigerant tank immediately after finishing the refrigerant charge operation.

The refrigerant charge port of these units have electric expansion valves that will close automatically when refrigerant charging operation has finished. However, the electric expansion valves will be opened when other operations start after finishing refrigerant charging operation. If the refrigerant tank is left with the valve open, the amount of refrigerant which is properly charged may be off the point.



If the LED indication is not as shown above, correct the malfunction (as indicated in the display of the remote control) and restart the complete charging procedure. When the charging amount is little, the *PE* code may not be displayed, but instead the *PS* code will be displayed immediately.



Beware of the fan blades when you open the front panel. The fan may still rotate for a while after unit operation has stopped.

10. In case leak detection function required

Press the **BS4 TEST** button once for post-processing with regard to the leak detection function and press the **BS1 MODE** button to confirm that charging is completed. Record the amount that was added on the additional refrigerant charge label provided with the unit and attach it on the back side of the front panel. Perform the procedure " 1.2.5.6 Procedure for inputting the additional refrigerant charge weight into the PC board" as described on page 170.

10. In case leak detection function not required

Press the **BS1 MODE** button once and the charging is complete. Record the amount that was added on the additional refrigerant charge label provided with the unit and attach it on the back side of the front panel. Perform the procedure " 1.2.5.6 Procedure for inputting the additional refrigerant charge weight into the PC board" as described on page 170.

2. Normal system display

LED display (Default status before delivery)	Micro- computer operation monitor	Mode	Ready/ Error	Cooling/Heating changeover			Low noise	Demand
				Indivi- dual	Bulk (master)	Bulk (slave)		
	HAP	H1P	H2P	H3P	H4P	H5P	H6P	H7P
Outdoor unit system								

3. Remote control malfunction code display

Remote control heating mode malfunction codes

Error code	
<i>P8</i> recharge operation	Close valve A immediately and press the TEST OPERATION button once. The operation will restart from the charging mode judgement onwards.
<i>P2</i> charge hold	Close valve A immediately. Check following items: - Check if the gas stop valve is opened correctly - Check if the valve of the refrigerant cylinder is opened - Check if the air inlet and outlet of the indoor unit are not obstructed After correcting the abnormality, restart the automatic charging procedure again.

Remote control cooling mode malfunction codes

Error code	
<i>PE</i>	Charging is almost finished. Ready to close valve A.
<i>P9</i>	Charging is finished. Close valve A and remove the refrigerant tank.
<i>PR, PH</i> replace cylinder	Close valve A and replace the empty cylinder. After replacing the cylinder, open valve A again and continue the work (the outdoor unit will not stop operating).
<i>P8</i> recharge operation	Close valve A immediately. Restart the automatic charging procedure again.
<i>P2</i> charge hold	Close valve A immediately. Check following items: - Check if the high pressure/low pressure gas pipe, suction gas pipe and liquid pipe stop valves are opened correctly - Check if the valve of the refrigerant cylinder is opened - Check if the air inlet and outlet of the indoor unit are not obstructed After correcting the abnormality, restart the automatic charging procedure again.
*	abnormal stop Close valve A immediately. Confirm the malfunction code by the remote control and correct the abnormality by following the "Correcting after abnormal completion of the test operation" on page 178.

1.2.5.6 Procedure for inputting the additional refrigerant charge weight into the PC board

Availability of the leak detection function feature requires input of the additional refrigerant charge amount immediately after finishing the automatic charging. The input must be executed before performing the test operation.



If a wrong value is input for the additional charged refrigerant weight, the accuracy of the leak detection function will decrease.

Procedure

1. Close the electric box lid and all front panels except the one on the side of the electric box.
2. Press and hold the **BS1 MODE** button for 5 seconds to enter into setting mode 2.

The H1P LED is on ☼.

3. Press the **BS2 SET** button 14 times.

The LED display must be as follows:



Press the **BS3 RETURN** button once as confirmation of the LEDs combination. LEDs will be blinking in function of the last entered setting (factory setting = 0 kg).

4. The weighed and already recorded amount of additional refrigerant charge (not the total amount of refrigerant present in the system) must be entered by selecting the corresponding LED display.

Scroll through the possible LED combinations by pressing the **BS2 SET** button until the LED combination corresponds to the weight of additional refrigerant charge you must input.

Select the required input by pressing the **BS3 RETURN** button and confirm the input into the PCB by pressing the **BS3 RETURN** button again.

Possible LED combinations in function of weight of additional refrigerant charge (= x) to input;

	kg	H1P	H2P	H3P	H4P	H5P	H6P	H7P
0	x=0	☀	●	●	●	●	●	●
1	0<x<5	☀	●	●	●	●	●	☀
2	5≤x<10	☀	●	●	●	●	☀	●
3	10≤x<15	☀	●	●	●	●	☀	☀
4	15≤x<20	☀	●	●	●	☀	●	●
5	20≤x<25	☀	●	●	●	☀	●	☀
6	25≤x<30	☀	●	●	●	☀	☀	●
7	30≤x<35	☀	●	●	●	☀	☀	☀
8	35≤x<40	☀	●	●	☀	●	●	●
9	40≤x<45	☀	●	●	☀	●	●	☀
10	45≤x<50	☀	●	●	☀	●	☀	●
11	50≤x<55	☀	●	●	☀	●	☀	☀
12	55≤x<60	☀	●	●	☀	☀	●	●
13	60≤x<65	☀	●	●	☀	☀	●	☀
14	65≤x<70	☀	●	●	☀	☀	☀	●
15	70≤x<75	☀	●	●	☀	☀	☀	☀
16	75≤x<80	☀	●	☀	●	●	●	●
17	80≤x<85	☀	●	☀	●	●	●	☀
18	85≤x<90	☀	●	☀	●	●	☀	●
19	90≤x<95	☀	●	☀	●	●	☀	☀
20	95≤x<100	☀	●	☀	●	☀	●	●
21	100≤x	☀	●	☀	●	☀	●	☀

5. Return to setting mode 1 (= initial state) by pressing the **BS1 MODE** button.



Note: If you get confused in the middle of the input process, press the **BS1 MODE** button to return to setting mode 1 (= initial state).

The H1P LED is off ●.

Resume the input procedure from step 2 onwards.

Perform a test operation as described in " 1.2.5.8.4 Test operation" on page 177.

1.2.5.7 Checks after adding refrigerant

- Are the stop valves for both liquid and gas open?
- Is the amount of refrigerant, that has been added, recorded on the refrigerant charge label?



Make sure to open the stop valves after charging the refrigerant.

Operating with the stop valves closed will damage the compressor.

1.2.5.8 Before operation

1.2.5.8.1 Service precautions



WARNING: ELECTRIC SHOCK



Caution when performing service to inverter equipment

1. Do not open the electric component box cover for 10 minutes after the power supply is turned off.
2. Measure the voltage between terminals on the terminal block for power supply with a tester and confirm that the power supply is shut off.
In addition, measure the points, as shown in the figure below, with a tester and confirm that the voltage of the capacitor in the main circuit is less than 50 V DC.

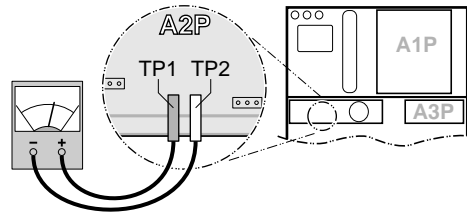

3. To prevent damaging the PC-board, touch a non-coated metal part to eliminate static electricity before pulling out or plugging in connectors.
4. Pull out junction connectors X1A, X2A, X3A, X4A (X3A and X4A of REYQ14+16P are inside the electric component box (2), refer to the wiring diagram) for the fan motors in the outdoor unit before starting service operation on the inverter equipment. Be careful not to touch the live parts.
(If a fan rotates due to strong wind, it may store electricity in the capacitor or in the main circuit and cause electric shock.)
5. After the service is finished, plug the junction connector back in. Otherwise the error code *E7* will be displayed on the remote control and normal operation will not be performed.

For details refer to the wiring diagram labelled on the back of the electric component box cover.

Pay attention to the fan. It is dangerous to inspect the unit while the fan is running. Be sure to turn off the main switch and to remove the fuses from the control circuit located in the outdoor unit.



Note: Play it safe!

For protection of the PC board, touch the switch box casing by hand in order to eliminate static electricity from your body before performing service.

1.2.5.8.2 Checks before initial start-up



Note: Remark that during the first running period of the unit, required power input may be higher than stated on the nameplate of the unit. This phenomenon originates from the compressor that needs elapse of a 50 hours run in period before reaching smooth operation and stable power consumption.



- Make sure that the circuit breaker on the power supply panel of the installation is switched off.
- Attach the power wire securely.
- Introducing power with a missing N-phase or with a mistaken N-phase will break the equipment.

After the installation, check the following before switching on the circuit breaker:

1. The position of the switches that require an initial setting
Make sure that switches are set according to your application needs before turning the power supply on.
2. Power supply wiring and transmission wiring
Use a designated power supply and transmission wiring and make sure that it has been carried out according to the instructions described in this manual, according to the wiring diagrams and according to local and national regulations.
3. Pipe sizes and pipe insulation
Make sure that correct pipe sizes are installed and that the insulation work is properly executed.
4. Air tight test and vacuum drying
Make sure the air tight test and vacuum drying were completed.
5. Additional refrigerant charge
The amount of refrigerant to be added to the unit should be written on the included "Added Refrigerant" plate and attached to the rear side of the front cover.
6. Insulation test of the main power circuit
Measure the insulation resistance and check if the value is in accordance with relevant local and national regulations..
7. Installation date and field setting
Be sure to keep record of the installation date on the sticker on the rear of the upper front panel according to EN60335-2-40. and keep record of the contents of the field setting.

1.2.5.8.3 Field setting

If required, carry out field settings according to the following instructions. Refer to the service manual for more details.

Opening the switch box and handling the switches

When carrying out field settings, remove the inspection cover (1).

Operate the switches with an insulated stick (such as a ball-point pen) to avoid touching live parts.

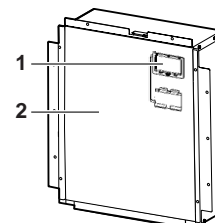

Make sure to re-attach the inspection cover (1) into the switch box cover (2) after the job is finished.



Note: Make sure that all outside panels, except for the panel on the electric component box (1), are closed while working.
Close the lid of the electric component box firmly before turning on the power.

Location of the DIP switches, LEDs and buttons

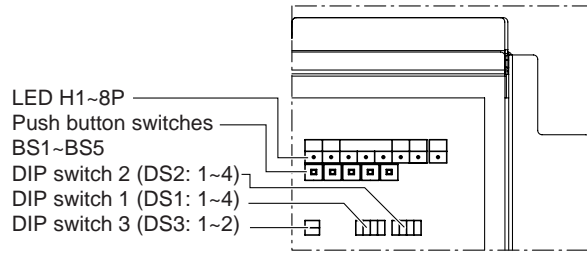

LED state

Throughout the manual the state of the LEDs is indicated as follows:

- OFF
- ☀ ON
- ⦿ Blinking

Setting the push button switch (BS1~5)

Function of the push button switch which is located on the outdoor unit PC board (A1P):

MODE	TEST: ⦿	C/H SELECT			L.N.O.P	DEMAND	MULTI
	HWL: ☀	IND	MASTER	SLAVE			
● H1P	● H2P	☀ H3P	● H4P	● H5P	● H6P	● H7P	● H8P

BS1 MODE	BS2 SET	BS3 RETURN	BS4 TEST	BS5 RESET
-------------	------------	---------------	-------------	--------------

- BS1 MODE** For changing the set mode
- BS2 SET** For field setting
- BS3 RETURN** For field setting
- BS4 TEST** For test operation
- BS5 RESET** For resetting the address when the wiring is changed or when an additional indoor unit is installed

The figure shows state of the LED indications when the unit is shipped from the factory.

Check operation procedure

1. Turn the power on for the outdoor unit and the indoor unit.
 Be sure to turn the power on at least 6 hours before operation in order to have power running to the crankcase heater.
2. Make sure that transmission is normal by checking the LED display on the outdoor unit circuit board (A1P). (If transmission is normal, each LED will be displayed as shown below.)

LED display (Default status before delivery)	Micro-computer operation monitor	Mode	Ready/Error	Cooling/Heating changeover			Low noise	Demand
				Individual	Bulk (master)	Bulk (slave)		
	HAP	H1P	H2P	H3P	H4P	H5P	H6P	H7P
Outdoor unit system	⦿	●	●	☀	●	●	●	●

Setting the mode

The set mode can be changed with the **BS1 MODE** button according to the following procedure:

- **For setting mode 1:** Press the **BS1 MODE** button once, the H1P LED is off ●. This mode is not available for heat recovery units.
- **For setting mode 2:** Press the **BS1 MODE** button for 5 seconds, the H1P LED is on ☀. If the H1P LED is blinking ⚡ and the **BS1 MODE** button is pushed once, the setting mode will change to setting mode 1.



Note: If you get confused in the middle of the setting process, push the **BS1 MODE** button. Then it returns to setting mode 1 (H1P LED is off).

Setting mode 2

The H1P LED is on.

Setting procedure

1. Push the **BS2 SET** button according to the required function (A~H). The LED indication that matches the required function is shown below in the field marked :

Possible functions

- A** additional refrigerant charging operation.
- B** refrigerant recovery operation/vacuuming operation.
- C** automatic low noise operation setting at nighttime.
- D** low noise operation level setting (**L.N.O.P**) via the external control adapter.
- E** power consumption limitation setting (**DEMAND**) via the external control adapter.
- F** enabling function of the low noise operation level setting (**L.N.O.P**) and/or power consumption limitation setting (**DEMAND**) via the external control adapter (DTA104A61/62).
- G** high static pressure setting
- H** evaporating temperature setting

	H1P	H2P	H3P	H4P	H5P	H6P	H7P
A	☀	●	☀	●	☀	●	●
B	☀	●	☀	●	☀	●	☀
C	☀	●	☀	●	☀	☀	●
D	☀	●	☀	☀	●	●	☀
E	☀	●	☀	☀	☀	☀	●
F	☀	●	●	☀	☀	●	●
G	☀	●	☀	●	●	☀	●
H	☀	●	●	☀	●	●	●

2. When the **BS3 RETURN** button is pushed, the current setting is defined.
 3. Push the **BS2 SET** button according to the required setting possibility as shown below in the field marked .
- 3.1 Possible settings for function A, B, F, and G are **ON** (ON) or **OFF** (OFF).

	H1P	H2P	H3P	H4P	H5P	H6P	H7P
ON	☀	●	●	●	●	☀	●
OFF^(a)	☀	●	●	●	●	●	☀

(a) This setting = factory setting

3.2 Possible settings for function C

The noise of level 3 < level 2 < level 1 (▲1).

	H1P	H2P	H3P	H4P	H5P	H6P	H7P
OFF^(a)	☀	●	●	●	●	●	●
▲1	☀	●	●	●	●	●	☀
▲2	☀	●	●	●	●	☀	●
▲3	☀	●	●	●	●	☀	☀

(a) This setting = factory setting

3.3 Possible settings for function D and E

For function D (**L.N.O.P**) only: the noise of level 3 < level 2 < level 1 (▲1).

For function E (**DEMAND**) only: the power consumption of level 1 < level 2 < level 3 (▲3).

	H1P	H2P	H3P	H4P	H5P	H6P	H7P
▲1	☀	●	●	●	●	●	☀
▲2 ^(a)	☀	●	●	●	●	☀	●
▲3	☀	●	●	●	☀	●	●

(a) This setting = factory setting

3.4 Possible settings for function H

The evaporating temperature level H (high) < level M (medium) < level L (low) (▲L).

	H1P	H2P	H3P	H4P	H5P	H6P	H7P
▲H	☀	●	●	●	●	●	☀
▲M ^(a)	☀	●	●	●	●	☀	●
▲L	☀	●	☀	●	●	●	●

(a) This setting = factory setting

4. Push the **BS3 RETURN** button and the setting is defined.
5. When the **BS3 RETURN** button is pushed again, the operation starts according to the setting.

Refer to the service manual for more details and for other settings.

Confirmation of the set mode

The following items can be confirmed by setting mode 1 (H1P LED is off)

Check the LED indication in the field marked .

1. Indication of the present operation state
 - ●, normal
 - ☀, abnormal
 - ☀, under preparation or under test operation

H1P	H2P	H3P	H4P	H5P	H6P	H7P
●	●	☀	●	●	●	●

2. Indication of low noise operation state **L.N.O.P**
 - ● standard operation (= factory setting)
 - ☀ **L.N.O.P** operation

H1P	H2P	H3P	H4P	H5P	H6P	H7P
●	●	☀	●	●	●	●

3. Indication of power consumption limitation setting **DEMAND**
 - ● standard operation (= factory setting)
 - ☀ **DEMAND** operation

H1P	H2P	H3P	H4P	H5P	H6P	H7P
●	●	☀	●	●	●	●

1.2.5.8.4 Test operation



Do not insert fingers, rods or other objects into the air inlet or outlet. When the fan is rotating at high speed, it will cause injury.



Do not perform the test operation while working on the indoor units.

When performing the test operation, not only the outdoor unit, but the connected indoor unit will operate as well. Working on a indoor unit while performing a test operation is dangerous.

- In case the unit is operated with the leak detection function available:
 - the outdoor temperature must be 0°C DB~43°C DB
 - the indoor temperature must be 20°C DB~32°C DB

In case the unit is operated out of the temperature range as instructed above, the display of the remote control shows *U3* and the unit operates without the availability of the leak detection function.
- In the test operation, the following checks and judgement will be performed:
 - Check of the stop valve opening
 - Check for wrong wiring
 - Check of refrigerant overcharge
 - Initial refrigerant detection
- In case the leak detection function is available, the check operation will last 2 hours, otherwise it takes between 40 and 60 minutes to complete the check operation.
- Make sure to carry out the test operation after the first installation. Otherwise, the malfunction code *U3* will be displayed on the remote control and normal operation can not be carried out.
- Abnormalities on indoor units can not be checked for each unit individual. After the test operation is finished, check the indoor units one by one by performing a normal operation using the remote control.



Note: A test operation can not be carried out when the outdoor temperature is less than -5°C.

Test operation procedure

1. Close all front panels except the front panel of the electric component box.
2. Turn ON the power to the outdoor unit and the connected indoor units.
Be sure to turn on the power 6 hours before operation in order to have power running to the crankcase heater and to protect the compressor.
3. Make the field setting as described in the paragraph " 1.2.5.8.3 Field setting" on page 173.
4. Press the **BS1 MODE** button once, and set to the SETTING MODE (H1P LED = OFF).
5. **In case the leak detection function is required,**
press and hold the BS4 TEST button down for 5 seconds or more. The unit will start the test operation.

In case the leak detection function is not required,

go into setting mode 2 by pressing the **BS1 MODE** button for 5 seconds. The H1P LED is on

☼. Perform following steps.

1. Press the **BS2 SET** button 3 times.



2. Press the **BS3 RETURN** button once to confirm.



3. Press the **BS2 SET** button in order to change the LED display to the following display.



4. Press the **BS3 RETURN** button once to confirm.

5. Press the **BS3 RETURN** button a second time to start the test operation. The unit will start the test operation.
 - The test operation is automatically carried out in cooling mode, the H2P LED will light up and the messages "Test operation" and "Under centralized control" will display on the remote control.
 - It may take 10 minutes to bring the state of the refrigerant uniform before the compressor starts.
 - During the test operation, the refrigerant running sound or the magnetic sound of a solenoid valve may become loud and the LED display may change, but these are not malfunctions.
 - During the test operation, it is not possible to stop the unit operation from a remote control. To abort the operation, press the **BS3 RETURN** button. The unit will stop after ±30 seconds.
6. Close the front panel in order to let it not be the cause of misjudgement.
7. Check the test operation results by the LED display on the outdoor unit.

	H1P	H2P	H3P	H4P	H5P	H6P	H7P
Normal completion	●	●	☉	●	●	●	●
Abnormal completion	●	☉	☉	●	●	●	●

8. When the test operation is fully completed, normal operation will be possible after 5 minutes. Otherwise, refer to "Correcting after abnormal completion of the test operation" on page 178 to take actions for correcting the abnormality.

Correcting after abnormal completion of the test operation

The test operation is only completed if there is no malfunction code displayed on the remote control. In case of a displayed malfunction code, perform the following actions to correct the abnormality:

- Confirm the malfunction code on the remote control

Installation error		
The stop valve of an outdoor unit is left closed.	<i>E3</i> <i>E4</i> <i>F3</i> <i>F6</i> <i>UF</i>	Open the stop valve.
The phases of the power to the outdoor unit is reversed.	<i>U1</i>	Exchange two of the three phases (L1, L2, L3) to make a positive phase connection.
No power is supplied to an outdoor or indoor unit (including phase interruption).	<i>LC</i> <i>U1</i> <i>U4</i>	Check if the power wiring for the outdoor units are connected correctly.
Incorrect interconnections between units.	<i>UF</i>	Check if the refrigerant line piping and the unit wiring are consistent with each other.
Refrigerant overcharge.	<i>E3</i> <i>F6</i> <i>UF</i>	Recalculate the required amount of refrigerant from the piping length and correct the refrigerant charge level by recovering any excessive refrigerant with a refrigerant recovery machine.
Insufficient refrigerant.	<i>E4</i> <i>F3</i>	Check if the additional refrigerant charge has been finished correctly. Recalculate the required amount of refrigerant from the piping length and add an adequate amount of refrigerant.
The added amount of refrigerant was not inputted after automatic charging.	<i>PF</i>	Availability of the leak detection function feature requires input of the additional refrigerant charge amount immediately after finishing the automatic charging. Refer to " 1.2.5.6 Procedure for inputting the additional refrigerant charge weight into the PC board" on page 170.
In case the test operation was interrupted or the unit was operating out of the instructed temperature range, the initial refrigerant detection has failed.	<i>U3</i>	In case the test operation was interrupted, perform the test operation again. In case the unit was operating out of the instructed temperature range, the unit can still be operated normally, but the leak detection function will not be available. Perform the test operation again within the instructed temperature range.

- After correcting the abnormality, press the **BS3 RETURN** button and reset the malfunction code.
- Carry out the test operation again and confirm that the abnormality is properly corrected.

1.2.5.8.5 Final check after installation

After all installation works are completed, operate the unit normally and check the following:

- Make sure the indoor units and outdoor unit are operating normally.
- Operate each indoor unit separately and make sure the corresponding outdoor unit is also operating properly.
- Check if cold or hot air is coming out from the indoor unit.
- Push the fan direction and fan strength buttons on the remote control to check if they are operating properly.



Note:

- Heating is not possible if the outdoor temperature is 24°C or higher. Refer to the operation manual.
- If a knocking sound is heard in the liquid compression of the compressor, stop the unit immediately and then energize the crankcase heater for a sufficient length of time before restarting the operation.
- Once stopped, the compressor will not restart in about 5 minutes, even if the ON/OFF button on the remote control is pushed.
- When the system operation is stopped by the remote control, the outdoor unit may continue operation for a maximum of 5 minutes.
- The outdoor fan may rotate at low speeds in the night-time low noise setting or the external low noise level setting is made; but this is not a malfunction.

1.2.5.8.6 Service mode operation



Note:

Do not shut off the power and do not reset the setting of mode 2 when vacuuming or recovering refrigerant. Otherwise the expansion valves will close making it impossible to vacuum the system or to recover the refrigerant.

Vacuumping method

At the first installation, this vacuuming is not required. It is required only for repair purposes.

1. When the unit is at standstill and under the setting mode 2, set the required function B (refrigerant recovery operation/vacuumping operation) to **ON** (ON).
 - The indoor unit, BS units and the outdoor unit expansion valves will fully open.
 - The H1P LED is on and the remote control indicates **TEST** (test operation) and  (external control) and the operation will be prohibited.
2. Evacuate the system with a vacuum pump.
3. Press the **BS1 MODE** button and reset the setting mode 2.

Refrigerant recovery operation method

by a refrigerant reclaimer

1. When the unit is at standstill and under the setting mode 2, set the required function B (refrigerant recovery operation/vacuumping operation) to **ON** (ON).
 - The indoor unit, BS unit and the outdoor unit expansion valves will fully open.
 - The H1P LED is on and the remote control indicates **TEST** (test operation) and  (external control) and the operation will be prohibited.
2. Recover the refrigerant by a refrigerant reclaimer. For details, see the operation manual delivered with the refrigerant reclaimer.
3. Press the **BS1 MODE** button and reset the setting mode 2.

1.2.5.8.7 Additional refrigerant charging method

When the leak detection function is not required and the entire refrigerant quantity can not be charged through the liquid pipe stop valve service port with the unit not operating (refer to "Pre-charging" on page 165), make sure to charge the remaining charging quantity using the following procedure:

1. Turn the power of the indoor unit, the BS unit and the outdoor unit on.
2. Make sure to open the stop valves of the suction gas pipe, the high pressure/low pressure gas pipe and the liquid pipe completely.
3. Connect the refrigerant charge hose to the refrigerant charging port (for additional charging).
4. When the unit is not operating, push the **BS2 SET** button until the additional refrigerant charging operation function A in setting mode 2 can be defined (refer to "Setting the mode" on page 175), the H1P LED is on (☼).
5. The operation starts automatically.
The H2P LED will start flashing (⚡) and the messages "Test operation" and "Under centralized control" will display on the remote control.
6. After charging the specified quantity of refrigerant, press the **BS3 RETURN** button to stop the operation.
The operation will stop within 30 minutes.
 - If charging is not completed after 30 minutes, set and perform the additional refrigerant charging operation again.
 - If the additional refrigerant charging operation stops before the passing of 30 minutes, the system may be overcharged.



Never charge extra refrigerant.

7. Disconnect the refrigerant charge hose.
8. Perform " 1.2.5.7 Checks after adding refrigerant" as explained on page 171.

1.2.6 Charging Refrigerant - REMQ8~16P8Y1B

The outdoor unit is factory charged, but depending on the length of the piping when installed, the outdoor unit may require additional charging.

For charging the additional refrigerant follow the procedure as described in this chapter.



Refrigerant cannot be charged until all field wiring and field piping has been completed. Refrigerant may only be charged after performing the leak test and the vacuum drying.



The refrigerant charge of the system must be less than 100 kg. This means that in case the calculated refrigerant charge is equal to or more than 95 kg you must divide your multiple outdoor system into smaller independent systems, each containing less than 95 kg refrigerant charge.

For factory charge, refer to the unit name plate.

1.2.6.1 Important information regarding the refrigerant used

This product contains fluorinated greenhouse gases covered by the Kyoto Protocol. Do not vent gases into the atmosphere.

Refrigerant type : R-410A

GWP⁽¹⁾ value : 1975

⁽¹⁾ GWP = global warming potential

Please fill in with indelible ink,

- ① the factory refrigerant charge of the product,
- ② the additional refrigerant amount charged in the field and
- ① + ② the total refrigerant charge

on the refrigerant charge label supplied with the product.

The filled out label must be adhered in the proximity of the product charging port (e.g. onto the inside of the service cover).

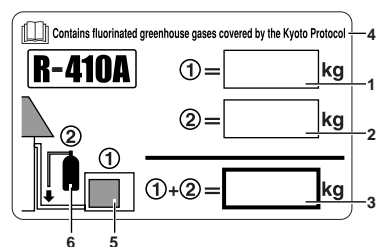

- 1 factory refrigerant charge of the product: see unit name plate⁽²⁾
- 2 additional refrigerant amount charged in the field
- 3 total refrigerant charge
- 4 contains fluorinated greenhouse gases covered by the Kyoto Protocol
- 5 outdoor unit
- 6 refrigerant cylinder and manifold for charging

⁽²⁾ In case of multiple outdoor systems, only 1 label must be adhered, mentioning the total factory refrigerant charge of all outdoor units connected on the refrigerant system.

1.2.6.2 Precautions when adding R-410A

Be sure to charge the specified amount of refrigerant in liquid state to the liquid pipe.

Since this refrigerant is a mixed refrigerant, adding it in gas form may cause the refrigerant composition to change, preventing normal operation.

- Before charging, check whether the refrigerant cylinder is equipped with a siphon tube or not.

Charge the liquid refrigerant with the cylinder in upright position.

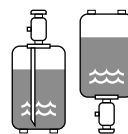

Charge the liquid refrigerant with the cylinder in up-side-down position.

- Be sure to use tools exclusively for R-410A to ensure required pressure resistance and to prevent foreign materials from mixing into the system.



Charging with an unsuitable substance may cause explosions and accidents, so always make sure that the appropriate refrigerant (R-410A) is charged.

Refrigerant containers must be opened slowly.

1.2.6.3 Stop valve operation procedure

Size of stop valve

The sizes of the stop valves connected to the system are as listed in the table below.

Type of stop valve	8 Hp	10 Hp	12 Hp	14 Hp	16 Hp
Liquid pipe		φ9.5 ^(a)		φ12.7	
Suction gas pipe		φ25.4 ^(b)			
HP/LP gas pipe		φ19.1 ^(c)			
Equalizer pipe		φ19.1			

(a) The 12 Hp model supports field piping of φ12.7 on the accessory pipe supplied with the unit.

(b) The 8 and 10 Hp models support field piping of φ22.2 on the accessory pipe supplied with the unit.

The 12~16 Hp models support field piping of φ28.6 on the accessory pipe supplied with the unit.

(c) The 14 and 16 Hp models support field piping of φ22.2 on the accessory pipe supplied with the unit.



- Do not open the stop valve until all piping and electrical steps of “1.2.4 Pipe Insulation” on page 161 are completed. If the stop valve is left open without turning on the power, it may cause refrigerant to build up in the compressor, leading to insulation degradation.
- Always use a charge hose for service port connection.
- After tightening the cap, check that no refrigerant leaks are present.

Opening stop valve (See figure 13)

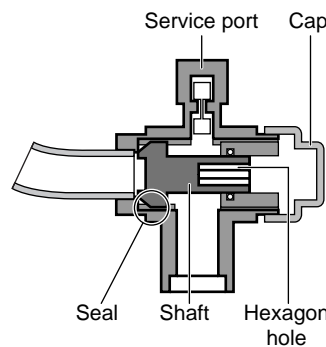

figure 13

1. Remove the cap and turn the valve counterclockwise with the hexagon wrench.
2. Turn it until the shaft stops.



Do not apply excessive force to the stop valve. Doing so may break the valve body.

3. Make sure to tighten the cap securely. Refer to the table below.

Stop valve size	Tightening torque N•m (Turn clockwise to close)			
	Shaft		Cap (valve lid)	Service port
	Valve body	Hexagonal wrench		
φ9.5	5.4~6.6	4 mm	13.5~16.5	11.5~13.9
φ12.7	8.1~9.9		18.0~22.0	
φ22.2	27.0~33.0	8 mm	22.5~27.5	
φ25.4				

Closing stop valve (See figure 13)

1. Remove the cap and turn the valve clockwise with the hexagon wrench.
2. Securely tighten the valve until the shaft contacts the main body seal.
3. Make sure to tighten the cap securely.

For the tightening torque, refer to the table above.

1.2.6.4 How to check how many units are connected

It is possible to find out how many indoor units are active and connected by operating the push-button switch on the printed circuit board (A1P) of the working outdoor unit. In a multiple outdoor unit system, you can find out how many outdoor units are connected to the system by using the same procedure.

Make sure that all the indoor units connected to the outdoor unit are active.

Follow the 5-step procedure as explained below.

- The LEDs on the A1P shows the operating status of the outdoor unit and the number of indoor units that are active.

● OFF ☀ ON ⚡ Blinking

- The number of units that are active can be read from the LED display in the "Monitor Mode" procedure below.

Example: in the following procedure there are 22 units active:



Note: Wherever during this procedure, press the **BS1 MODE** button if something becomes unclear. You will return to setting mode 1 (H1P= ● "OFF").

1 Setting mode 1 (default system status)

	H1P	H2P	H3P	H4P	H5P	H6P	H7P
Default status (normal)	●	●	☀	●	●	●	●

Press the **BS1 MODE** button to switch from setting mode 1 to monitor mode.

2 Monitor mode

	H1P	H2P	H3P	H4P	H5P	H6P	H7P
Default status display	⚡	●	●	●	●	●	●

To check the number of indoor units, press the **BS2 SET** button 5 times.
To check the number of outdoor units, press the **BS2 SET** button 8 times.

3 Monitor mode

	H1P	H2P	H3P	H4P	H5P	H6P	H7P
Selection status of how many connected indoor units to display.	⚡	●	●	●	☀	●	☀
OR							
	H1P	H2P	H3P	H4P	H5P	H6P	H7P
Selection status of how many connected outdoor units to display.	⚡	●	●	☀	●	●	●

Pressing the **BS3 RETURN** button causes the LED display to show the data on the number of indoor units that are connected or how many outdoor units that are connected in a multiple outdoor unit system.

4 Monitor mode

	H1P	H2P	H3P	H4P	H5P	H6P	H7P	
Displaying the number of connected indoor units	⚡	●	⚡	●	⚡	⚡	●	
			32	16	8	4	2	1

Calculate the number of connected indoor units by adding the values of all (H2P~H7P) blinking (⚡) LEDs together.

In this example: 16+4+2=22 units

Press the **BS1 MODE** button to return to step 1, setting mode 1 (H1P= ● "OFF").

1.2.6.5 Additional refrigerant charge



Adding refrigerant using the automatic refrigerant charging function is recommended.

Follow the procedures below.



- When charging a system, charging over the permissible quantity can cause liquid hammer.
- Always use protective gloves and protect your eyes when charging refrigerant.
- When the refrigerant charging procedure is done or when pausing, close the valve of the refrigerant tank immediately.
 - The refrigerant charge port has a electric expansion valve and will be closed at the end of the refrigerant charging. However, the valve will be opened when operating the unit after refrigerant charging.
 - If the tank is left with the valve open, the amount of refrigerant which is properly charged may get off point. More refrigerant may be charged by any remaining pressure after the unit has stopped.



Electric shock warning

- Close the electric box lid before turning on the main power.
 - Perform the settings on the circuit board (A1P) of the outdoor unit and check the LED display after the power is on via the service lid which is in the lid of the electric box.
- Operate switches with an insulated stick (such as a ball-point pen) to avoid touching the life parts.
- Make sure to re-attach the inspection cover into the switch box cover after the job is finished.



- If the power of some units is turned off, the charging procedure can not be finished properly.
- In case of a multiple outdoor system, turn on the power of all outdoor units.
- Make sure to turn ON the power 6 hours before starting the operation. This is necessary to warm the crankcase by the electric heater.
- If operation is performed within 12 minutes after the indoor, BS unit and outdoor units are turned on, the H2P-LED will be lit and the compressor will not operate.



Note:

- See " 1.2.6.3 Stop valve operation procedure" on page 182 for details on how to handle stop valves.
- The refrigerant charging port is connected to the piping inside the unit. The unit's internal piping is already factory charged with refrigerant, so be careful when connecting the charge hose.
- After adding the refrigerant, do not forget to close the lid of the refrigerant charging port. The tightening torque for the lid is 11.5 to 13.9 N•m.
- In order to ensure uniform refrigerant distribution, it may take the compressor ±10 minutes to start up after the unit has started operation. This is not a malfunction.

1. Procedure for additional refrigerant charge

The automatic refrigerant charging has limits as described below.

At out of limit, the system can not operate the automatic refrigerant charging.

Outdoor temperature	: 0°C DB~43°C DB
Indoor temperature	: 10°C DB~32°C DB
Total indoor unit capacity	: ≥80%

Pre-charging

To speed up the proces of charging refrigerant for large systems, it is recommended to first manually charge a portion of the refrigerant first before performing automatic charging.

1. Calculate how much refrigerant to be added using the formula explained in the chapter "How to calculate the additional refrigerant to be charged" on page 158.
2. The amount of pre-charging is 10 kg less than the calculated amount.

3. Open valve B (the valves A and C, the liquid pipe, the suction gas pipe, the high pressure/ low pressure gas pipe and the equalizer pipe stop valves must be left closed) and charge the refrigerant in liquid form via the liquid pipe stop valve service port. (See figure 24)

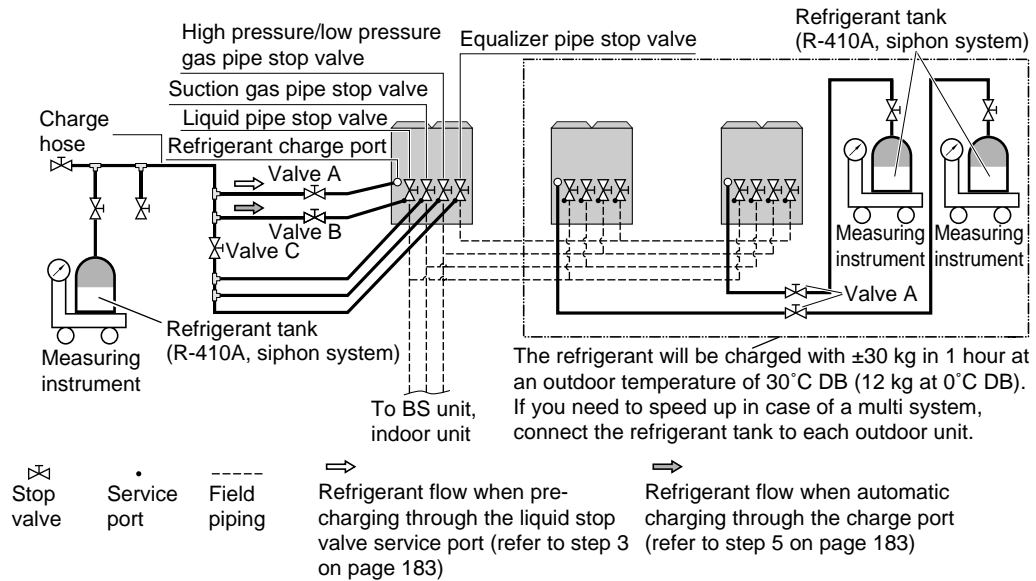

figure 24

4. If the calculated amount of pre-charging is reached, close valve B.



At least the unit should be charged with its original amount of refrigerant (refer to the nameplate on the unit), before starting the automatic charging.

**Note:**

When the leak detection function is not required, complete charging when using the previous described method (unit is not operating) can be done. If it is not possible to charge the entire quantity through the service port of the liquid pipe stop valve with the unit not operating, refer to "1.2.6.8.7 Additional refrigerant charging method" on page 199.

5. After pre-charging, perform the refrigerant charge operation as shown below and charge the remaining refrigerant of the additional charging amount through valve A. (See figure 24)

**Note:**

For a multi outdoor unit system, it is not required to connect all charge ports to a refrigerant tank. The refrigerant will be charged with ± 30 kg in 1 hour time at an outdoor temperature of 30°C DB or with ± 12 kg at an outdoor temperature of 0°C DB. If you need to speed up in case of a multiple outdoor system, connect the refrigerant tanks to each outdoor unit as shown in figure 24.

1. Start of automatic charging refrigerant

- Open the liquid pipe, suction gas pipe, high pressure/low pressure gas pipe and equalizer pipe stop valves and the service port stop valve. (Valves A, B and C must be closed.)
- Close all front panels except the electric box front panel and turn the power ON.
- Make sure all indoor units are connected, refer to "1.2.6.4 How to check how many units are connected" on page 183.
- If the H2P LED is not flashing (in 12 minutes time after turning on the power), make sure it is displayed as shown in the "2. Normal system display" on page 188. If the H2P LED is flashing, check the malfunction code on the remote control "3. Remote control malfunction code display" on page 189.



- If you perform the refrigerant charging operation within the refrigerant system with one or more units with power OFF, the refrigerant charging operation can not be accomplished properly. For confirming the number of outdoor units and indoor units with power ON, refer to "1.2.6.4 How to check how many units are connected" on page 183. In case of a multi system, turn the power ON to all outdoor units in the refrigerant system.

- To energize the crankcase heater, make sure to turn the power ON at least 6 hours before starting operation.
2. Press the **BS1 MODE** button once if the LEDs combination is not as in the figure below.



3. Press the **BS4 TEST** button once.



4. Hold the **BS4 TEST** button down for 5 seconds or more.

5. Charging mode judgement

However, if the indoor temperature is 10°C DB or lower, in some cases the unit will charge in heating mode to increase the indoor temperature.

The unit will automatically select the cooling mode or heating mode for charging.



- When charging in cooling mode, the unit will stop operating when the required amount of refrigerant is charged.
- During charging in heating mode, a person must manually close valve A before complete charging is finished. The required amount is the calculated amount (see "6. Example of connection" on page 450), therefore, the weight must be monitored constantly.

■ Charging in heating mode

6. Start up

Wait while the unit is preparing for charging in heating mode.

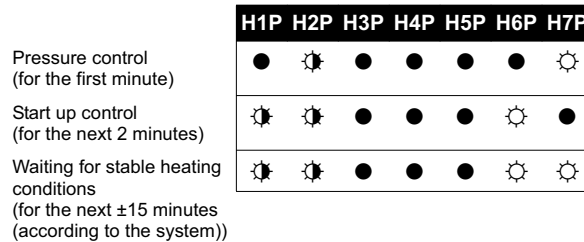

It takes about 2 to 10 minutes for the system to become stable.

In case of a small charging amount, the system will start charging the refrigerant before the system reaches the stable state. It may disturb a correct decision and may cause overcharging.

7. Ready



Press the **BS4 TEST** button once within 5 minutes.

If the **BS4 TEST** button is not pushed within 5 minutes, **P2** will be displayed on the remote control. Refer to "3. Remote control malfunction code display" on page 189.

8. Operation

When the following LED display is shown, open valve A and close the front panel. If the front panel is left open, the system can not operate properly during the refrigerant charging.



When the refrigerant tank is not connected or is left with the valve closed for 30 minutes or more, the outdoor unit will stop operation and the **P2** code will be displayed on the remote control of the indoor unit. Follow the procedure as described in "3. Remote control malfunction code display" on page 189.



* = The state of this LED is not important.



When a malfunction occurs, check the display of the remote control and refer to "3. Remote control malfunction code display" on page 189.

9. Complete

If the calculated amount of refrigerant is reached, close valve A and press the **BS3 RETURN** button once.



Note: Always close valve A and remove the refrigerant tank immediately after finishing the refrigerant charge operation.



10. In case leak detection function is required

Press the **BS4 TEST** button once for post-processing with regard to the leak detection function and press the **BS1 MODE** button to confirm that charging is completed. Record the amount that was added on the additional refrigerant charge label provided with the unit and attach it on the back side of the front panel. Perform the procedure " 1.2.6.6 Procedure for inputting the additional refrigerant charge weight into the PC board" as described on page 189.

10. In case leak detection function is not required

Press the **BS1 MODE** button once and the charging is complete. Record the amount that was added on the additional refrigerant charge label provided with the unit and attach it on the back side of the front panel. Perform the procedure " 1.2.6.6 Procedure for inputting the additional refrigerant charge weight into the PC board" as described on page 189.

■ **Charging in cooling mode**

6. Start up

Wait while the unit is preparing for charging in cooling mode.

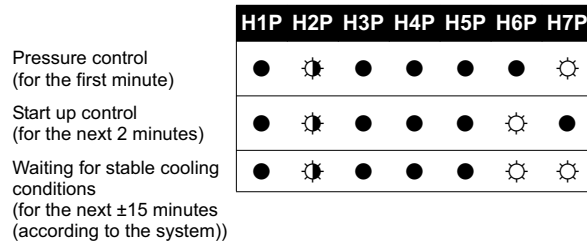

It takes about 2 to 10 minutes for the system to become stable.

In case of a small charging amount, the system will start charging the refrigerant before the system reaches the stable state. It may disturb a correct decision and may cause overcharging.

7. Ready



Press the **BS4 TEST** button once within 5 minutes.

If the **BS4 TEST** button is not pushed within 5 minutes, **P2** will be displayed on the remote control. Refer to "3. Remote control malfunction code display" on page 189.

8. Operation

When the following LED display is shown, open valve A and close the front panel. If the front panel is left open, the system can not operate properly during the refrigerant charging.



When the refrigerant tank is not connected or is left with the valve closed for 30 minutes or more, the outdoor unit will stop operation and the **P2** code will be displayed on the remote control of the indoor unit. Follow the procedure as described in "3. Remote control malfunction code display" on page 189.



* = The state of this LED is not important.



When a malfunction occurs, check the display of the remote control and refer to "3. Remote control malfunction code display" on page 189.

9. Complete



The display on the remote control shows a flashing *PE* code for signalling that automatic charging will be finished in about 10 minutes.

When the unit stops operating, close valve A immediately and check the LEDs and check if the *PS* code is displayed on the remote control.



Note: Always close valve A and remove the refrigerant tank immediately after finishing the refrigerant charge operation.

The refrigerant charge port of these units have electric expansion valves that will close automatically when refrigerant charging operation has finished. However, the electric expansion valves will be opened when other operations start after finishing refrigerant charging operation. If the refrigerant tank is left with the valve open, the amount of refrigerant which is properly charged may be off the point.



If it is not as shown above, correct the malfunction (as indicated in the display of the remote control) and restart the complete charging procedure. When the charging amount is little, the *PE* code may not be displayed, but instead the *PS* code will be displayed immediately.

10. In case leak detection function required

Press the **BS4 TEST** button once for post-processing with regard to the leak detection function and press the **BS1 MODE** button to confirm that charging is completed.

Record the amount that was added on the additional refrigerant charge label provided with the unit and attach it on the back side of the front panel.

Perform the procedure " 1.2.6.6 Procedure for inputting the additional refrigerant charge weight into the PC board" as described on page 189.

10. In case leak detection function not required

Press the **BS1 MODE** button once and the charging is complete.

Record the amount that was added on the additional refrigerant charge label provided with the unit and attach it on the back side of the front panel.

Perform the procedure " 1.2.6.6 Procedure for inputting the additional refrigerant charge weight into the PC board" as described on page 189.

2. Normal system display

LED display (Default status before delivery)	Micro- computer operation monitor	Mode	Ready/ Error	Cooling/Heating changeover			Low noise	Demand	Multi
				Indivi- dual	Bulk (master)	Bulk (slave)			
	HAP	H1P	H2P	H3P	H4P	H5P	H6P	H7P	H8P
Single outdoor unit system									
Multiple outdoor unit system	Master unit ^(a)								
	Slave unit 1 ^(a)								
	Slave unit 2 ^(a)								

(a) The state of the H8P (multi) LED in a multi-system shows which unit is the master unit (), slave 1 unit () or slave 2 unit ()

Only the master unit is connected to the indoor units with interunit wiring.

3. Remote control malfunction code display

Remote control heating mode malfunction codes

Error code	
<i>PB</i> recharge operation	Close valve A immediately and press the TEST OPERATION button once. The operation will restart from the charging mode judgement onwards.
<i>P2</i> charge hold	Close valve A immediately. Check following items: - Check if the gas side stop valve is opened correctly - Check if the valve of the refrigerant cylinder is opened - Check if the air inlet and outlet of the indoor unit are not obstructed After correcting the abnormality, restart the automatic charging procedure again.

Remote control cooling mode malfunction codes

Error code	
<i>PR, PH, PC</i> replace cylinder	Close valve A and replace the empty cylinder. When renewed, open valve A (the outdoor unit will not stop operating). The code on the display shows the unit where a cylinder is to be renewed: <i>PR</i> = master unit, <i>PH</i> = slave unit 1, <i>PC</i> = slave unit 2, flashing <i>PR</i> , <i>PH</i> and <i>PC</i> = all units After replacing the cylinder, open valve A again and continue the work.  In case of an outdoor multi system, replacing the refrigerant tank of the outdoor unit during the refrigerant charging operation when the display on the remote control is not showing <i>PR</i> , <i>PH</i> or <i>PC</i> , may cause an abnormal stop of the refrigerant charging operation.
<i>PB</i> recharge operation	Close valve A immediately. Restart the automatic charging procedure again.
<i>P2</i> charge hold	Close valve A immediately. Check following items: - Check if the high pressure/low pressure gas pipe, suction gas pipe, liquid pipes and equalizer pipe stop valves are opened correctly - Check if the valve of the refrigerant cylinder is opened - Check if the air inlet and outlet of the indoor unit are not obstructed After correcting the abnormality, restart the automatic charging procedure again.
* abnormal stop	Close valve A immediately. Confirm the malfunction code by the remote control and correct the abnormality by following the "Correcting after abnormal completion of the test operation" on page 197.

1.2.6.6 Procedure for inputting the additional refrigerant charge weight into the PC board

Availability of the leak detection function feature requires input of the additional refrigerant charge amount immediately after finishing the automatic charging. The input must be executed before performing the test operation.



If a wrong value is inputted for the additional charged refrigerant weight, the accuracy of the leak detection function will decrease.

Procedure

1. Close the electric box lid and all front panels except the one on the side of the electric box.
2. Press and hold the **BS1 MODE** button for 5 seconds to enter into setting mode 2.

The H1P LED is on .

3. Press the **BS2 SET** button 14 times.

The LED display must be as follows:

H1P	H2P	H3P	H4P	H5P	H6P	H7P
						

Press the **BS3 RETURN** button once as confirmation of the LEDs combination.

LEDs will be blinking in function of the last entered setting (factory setting = 0 kg).

4. The weighed and already recorded amount of additional refrigerant charge (not the total amount of refrigerant present in the system) must be entered by selecting the corresponding LED display.

Scroll through the possible LED combinations by pressing the **BS2 SET** button until the LED

combination corresponds to the weight of additional refrigerant charge you must input. Select the required input by pressing the **BS3 RETURN** button and confirm the input into the PCB by pressing the **BS3 RETURN** button again.

Possible LED combinations in function of weight of additional refrigerant charge (= x) to input;

	kg	H1P	H2P	H3P	H4P	H5P	H6P	H7P
0	x=0	☀	●	●	●	●	●	●
1	0<x<5	☀	●	●	●	●	●	☀
2	5≤x<10	☀	●	●	●	●	☀	●
3	10≤x<15	☀	●	●	●	●	☀	☀
4	15≤x<20	☀	●	●	●	☀	●	●
5	20≤x<25	☀	●	●	●	☀	●	☀
6	25≤x<30	☀	●	●	●	☀	☀	●
7	30≤x<35	☀	●	●	●	☀	☀	☀
8	35≤x<40	☀	●	●	☀	●	●	●
9	40≤x<45	☀	●	●	☀	●	●	☀
10	45≤x<50	☀	●	●	☀	●	☀	●
11	50≤x<55	☀	●	●	☀	●	☀	☀
12	55≤x<60	☀	●	●	☀	☀	●	●
13	60≤x<65	☀	●	●	☀	☀	●	☀
14	65≤x<70	☀	●	●	☀	☀	☀	●
15	70≤x<75	☀	●	●	☀	☀	☀	☀
16	75≤x<80	☀	●	☀	●	●	●	●
17	80≤x<85	☀	●	☀	●	●	●	☀
18	85≤x<90	☀	●	☀	●	●	☀	●
19	90≤x<95	☀	●	☀	●	●	☀	☀
20	95≤x<100	☀	●	☀	●	☀	●	●
21	100≤x	☀	●	☀	●	☀	●	☀

5. Return to setting mode 1 (= initial state) by pressing the **BS1 MODE** button.



Note: If you get confused in the middle of the input process, press the **BS1 MODE** button to return to setting mode 1 (= initial state).

The H1P LED is off ●.

Resume the input procedure from step 2 onwards.

Perform a test operation as described in " 1.2.6.8.4 Test operation" on page 196.

1.2.6.7 Checks after adding refrigerant

- Are the stop valves for both liquid and gas open?
- Is the amount of refrigerant, that has been added, recorded?



Make sure to open the stop valves after charging the refrigerant. Operating with the stop valves closed will damage the compressor.

1.2.6.8 Before operation

1.2.6.8.1 Service precautions



WARNING: ELECTRIC SHOCK



Caution when performing service to inverter equipment

1. Do not open the electric box cover for 10 minutes after the power supply is turned off.
2. Measure the voltage between terminals on the terminal block for power supply with a tester and confirm that the power supply is shut off.

In addition, measure the points, as shown in the figure below, with a tester and confirm that the voltage of the capacitor in the main circuit is less than 50 V DC.

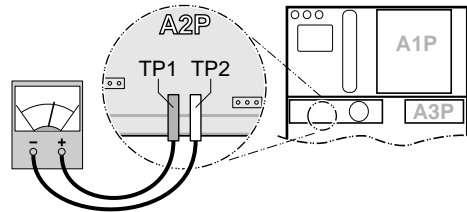

3. To prevent damaging the PC-board, touch a noncoated metal part to eliminate static electricity before pulling out or plugging in connectors.
4. The performing of the service to the inverter equipment must be started after the junction connectors X1A, X2A, X3A, X4A (X3A and X4A are for 14+16 unit type only) for the fan motors in the outdoor unit are been pulled out. Be careful not to touch the live parts. (If a fan rotates due to strong wind, it may store electricity in the capacitor or in the main circuit and cause electric shock.)
5. After the service is finished, plug the junction connector back in. Otherwise the error code *E7* will be displayed on the remote control and normal operation will not be performed. For details refer to the wiring diagram labelled on the back of the electric box cover.

Pay attention to the fan. It is dangerous to inspect the unit while the fan is running. Be sure to turn off the main switch and to remove the fuses from the control circuit located in the outdoor unit.



Note: Play it safe!

For protection of the PC board, touch the switch box casing by hand in order to eliminate static electricity from your body before performing service.

1.2.6.8.2 Checks before initial start-up



Note: Remark that during the first running period of the unit, required power input may be higher than stated on the nameplate of the unit. This phenomenon originates from the compressor that needs elapse of a 50 hours run in period before reaching smooth operation and stable power consumption.



- Make sure that the circuit breaker on the power supply panel of the installation is switched off.
- Attach the power wire securely.
- Introducing power with a missing N-phase or with a mistaken N-phase will break the equipment.

After the installation, check the following before switching on the circuit breaker:

1. The position of the switches that require an initial setting
Make sure that switches are set according to your application needs before turning the power supply on.
2. Power supply wiring and transmission wiring
Use a designated power supply and transmission wiring and make sure that it has been carried out according to the instructions described in this manual, according to the wiring diagrams and according to local and national regulations.
3. Pipe sizes and pipe insulation
Make sure that correct pipe sizes are installed and that the insulation work is properly executed.
4. Air tight test and vacuum drying
Make sure the air tight test and vacuum drying were completed.
5. Additional refrigerant charge
The amount of refrigerant to be added to the unit should be written on the included "Added Refrigerant" plate and attached to the rear side of the front cover.
6. Insulation test of the main power circuit
Measure the insulation resistance and check if the value is in accordance with relevant local and national regulations.
7. Installation date and field setting
Be sure to keep record of the installation date on the sticker on the rear of the upper front panel according to EN60335-2-40. and keep record of the contents of the field setting.

1.2.6.8.3 Field setting

If required, carry out field settings according to the following instructions. Refer to the service manual for more details.

Opening the switch box and handling the switches

When carrying out field settings, remove the inspection cover (1).

Operate the switches with an insulated stick (such as a ball-point pen) to avoid touching live parts.

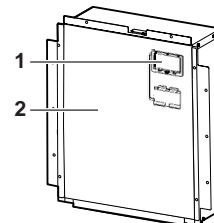

Make sure to re-attach the inspection cover (1) into the switch box cover (2) after the job is finished.



Note: Make sure that all outside panels, except for the panel on the electric box, are closed while working.
Close the lid of the electric box firmly before turning on the power.

Location of the dip switches, LEDs and buttons

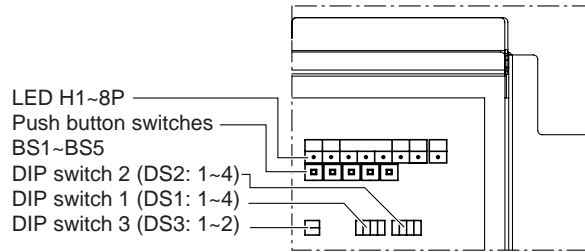

LED state

Throughout the manual the state of the LEDs is indicated as follows:

- OFF
- ☀ ON
- ⚡ Blinking

Setting the push button switch (BS1~5)

Function of the push button switch which is located on the outdoor unit PC board (A1P):

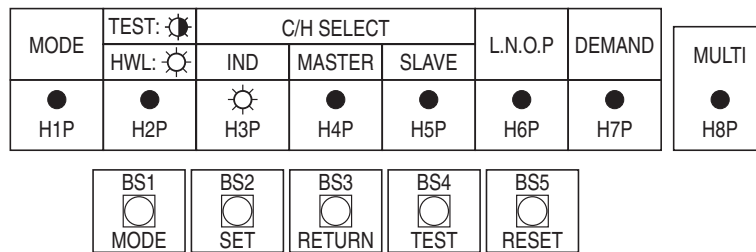

- BS1 MODE** For changing the set mode
- BS2 SET** For field setting
- BS3 RETURN** For field setting
- BS4 TEST** For test operation
- BS5 RESET** For resetting the address when the wiring is changed or when an additional indoor unit is installed

The figure shows state of the LED indications when the unit is shipped from the factory.

Check operation procedure

1. Turn the power on for the outdoor unit and the indoor unit.
Be sure to turn the power on at least 6 hours before operation in order to have power running to the crankcase heater.
2. Make sure that transmission is normal by checking the LED display on the outdoor unit circuit board (A1P). (If transmission is normal, each LED will be displayed as shown below.)

LED display (Default status before delivery)	Micro-computer operation monitor	Mode	Ready/Error	Cooling/Heating changeover			Low noise	Demand	Multi
				Individual	Bulk (master)	Bulk (slave)			
	HAP	H1P	H2P	H3P	H4P	H5P	H6P	H7P	H8P
Single outdoor unit system	⚡	●	●	☀	●	●	●	●	●
Multiple outdoor unit system	Master unit ^(a)	⚡	●	●	☀	●	●	●	☀
	Slave unit 1 ^(a)	⚡	●	●	●	●	●	●	⚡
	Slave unit 2 ^(a)	⚡	●	●	●	●	●	●	●

(a) The state of the H8P (multi) LED in a multi-system shows which unit is the master unit (☀), slave 1 unit (⚡) or slave 2 unit (●).

Only the master unit is connected to the indoor units with interunit wiring.

Setting the mode

The set mode can be changed with the **BS1 MODE** button according to the following procedure:

- **For setting mode 1:** Press the **BS1 MODE** button once, the H1P LED is off ●. This mode is not available for heat recovery units.
- **For setting mode 2:** Press the **BS1 MODE** button for 5 seconds, the H1P LED is on ☀. If the H1P LED is blinking ☀ and the **BS1 MODE** button is pushed once, the setting mode will change to setting mode 1.



Note: If you get confused in the middle of the setting process, push the **BS1 MODE** button. Then it returns to setting mode 1 (H1P LED is off).

Setting mode 2

The H1P LED is on.

Setting procedure

1. Push the **BS2 SET** button according to the required function (A~H). The LED indication that matches the required function is shown below in the field marked :

Possible functions

- A** additional refrigerant charging operation.
- B** refrigerant recovery operation/vacuumping operation.
- C** automatic low noise operation setting at nighttime.
- D** low noise operation level setting (**L.N.O.P**) via the external control adapter.
- E** power consumption limitation setting (**DEMAND**) via the external control adapter.
- F** enabling function of the low noise operation level setting (**L.N.O.P**) and/or power consumption limitation setting (**DEMAND**) via the external control adapter (DTA104A61/62).
- G** high static pressure setting
- H** evaporating temperature setting

	H1P	H2P	H3P	H4P	H5P	H6P	H7P
A	☀	●	☀	●	☀	●	●
B	☀	●	☀	●	☀	●	☀
C	☀	●	☀	●	☀	☀	●
D	☀	●	☀	☀	●	●	☀
E	☀	●	☀	☀	☀	☀	●
F	☀	●	●	☀	☀	●	●
G	☀	●	☀	●	●	☀	●
H	☀	●	●	☀	●	●	●

2. When the **BS3 RETURN** button is pushed, the current setting is defined.
 3. Push the **BS2 SET** button according to the required setting possibility as shown below in the field marked .
- 3.1 Possible settings for function A, B, F, and G are **ON** (ON) or **OFF** (OFF).

	H1P	H2P	H3P	H4P	H5P	H6P	H7P
ON	☀	●	●	●	●	☀	●
OFF^(a)	☀	●	●	●	●	●	☀

(a) This setting = factory setting

3.2 Possible settings for function C

The noise of level 3 < level 2 < level 1 (▲1).

	H1P	H2P	H3P	H4P	H5P	H6P	H7P
OFF^(a)	☀	●	●	●	●	●	●
▲1	☀	●	●	●	●	●	☀
▲2	☀	●	●	●	●	☀	●
▲3	☀	●	●	●	●	☀	☀

(a) This setting = factory setting

3.3 Possible settings for function D and E

For function D (**L.N.O.P**) only: the noise of level 3 < level 2 < level 1 (▲1).

For function E (**DEMAND**) only: the power consumption of level 1 < level 2 < level 3 (▲3).

	H1P	H2P	H3P	H4P	H5P	H6P	H7P
▲1	☀	●	●	●	●	●	☀
▲2 ^(a)	☀	●	●	●	●	☀	●
▲3	☀	●	●	●	☀	●	●

(a) This setting = factory setting

3.4 Possible settings for function H

The evaporating temperature level H (high) < level M (medium) < level L (low) (▲L).

	H1P	H2P	H3P	H4P	H5P	H6P	H7P
▲H	☀	●	●	●	●	●	☀
▲M ^(a)	☀	●	●	●	●	☀	●
▲L	☀	●	☀	●	●	●	●

(a) This setting = factory setting

4. Push the **BS3 RETURN** button and the setting is defined.
5. When the **BS3 RETURN** button is pushed again, the operation starts according to the setting.

Refer to the service manual for more details and for other settings.

Confirmation of the set mode

The following items can be confirmed by setting mode 1 (H1P LED is off)

Check the LED indication in the field marked .

1. Indication of the present operation state
 - ●, normal
 - ☀, abnormal
 - ☀, under preparation or under test operation

H1P	H2P	H3P	H4P	H5P	H6P	H7P
●	●	☀	●	●	●	●

2. Indication of low noise operation state **L.N.O.P**
 - ● standard operation (= factory setting)
 - ☀ **L.N.O.P** operation

H1P	H2P	H3P	H4P	H5P	H6P	H7P
●	●	☀	●	●	●	●

3. Indication of power consumption limitation setting **DEMAND**
 - ● standard operation (= factory setting)
 - ☀ **DEMAND** operation

H1P	H2P	H3P	H4P	H5P	H6P	H7P
●	●	☀	●	●	●	●

1.2.6.8.4 Test operation



Do not insert fingers, rods or other objects into the air inlet or outlet. When the fan is rotating at high speed, it will cause injury.



Do not perform the test operation while working on the indoor units.

When performing the test operation, not only the outdoor unit, but the connected indoor unit will operate as well. Working on a indoor unit while performing a test operation is dangerous.

- In case the unit is operated with the leak detection function available:
 - the outdoor temperature must be 0°C DB~43°C DB
 - the indoor temperature must be 20°C DB~32°C DB

In case the unit is operated out of the temperature range as instructed above, the display of the remote control shows *U3* and the unit operates without the availability of the leak detection function.
- In the test operation, the following checks and judgement will be performed:
 - Check of the stop valve opening
 - Check for wrong wiring
 - Check of refrigerant overcharge
 - Initial refrigerant detection
- In case the leak detection function is available, the check operation will last 2 hours, otherwise it takes between 40 and 60 minutes to complete the check operation.
- Make sure to carry out the test operation after the first installation. Otherwise, the malfunction code *U3* will be displayed on the remote control and normal operation can not be carried out.
- In case of a multi system, check the settings and results on the master unit.
- Abnormalities on indoor units can not be checked for each unit individual. After the test operation is finished, check the indoor units one by one by performing a normal operation using the remote control.



Note: A test operation can not be carried out when the outdoor temperature is less than -5°C.

Test operation procedure

1. Close all front panels except the front panel of the electric box.
2. Turn ON the power to all outdoor units and the connected indoor units.
Be sure to turn on the power 6 hours before operation in order to have power running to the crank case heater and to protect the compressor.
3. Make the field setting as described in the paragraph " 1.2.6.8.3 Field setting" on page 192.
4. Press the **BS1 MODE** button once, and set to the SETTING MODE (H1P LED = OFF).
5. **In case the leak detection function is required,**
press and hold the **BS4 TEST** button down for 5 seconds or more. The unit will start the test operation.

In case the leak detection function is not required,

go into setting mode 2 by pressing the **BS1 MODE** button for 5 seconds. The H1P LED is on Perform following steps.

1. Press the **BS2 SET** button 3 times.



2. Press the **BS3 RETURN** button once to confirm.



3. Press the **BS2 SET** button in order to change the LED display to the following display.



4. Press the **BS3 RETURN** button once to confirm.

5. Press the **BS3 RETURN** button a second time to start the test operation. The unit will start the test operation.
 - The test operation is automatically carried out in cooling mode, the H2P LED will light up and the messages "Test operation" and "Under centralized control" will display on the remote control.
 - It may take 10 minutes to bring the state of the refrigerant uniform before the compressor starts.
 - During the test operation, the refrigerant running sound or the magnetic sound of a solenoid valve may become loud and the LED display may change, but these are not malfunctions.
 - During the test operation, it is not possible to stop the unit operation from a remote control. To abort the operation, press the **BS3 RETURN** button. The unit will stop after ±30 seconds.
6. Close the front panel in order to let it not be the cause of misjudgement.
7. Check the test operation results by the LED display on the outdoor unit.

	H1P	H2P	H3P	H4P	H5P	H6P	H7P
Normal completion	●	●	☼	●	●	●	●
Abnormal completion	●	☼	☼	●	●	●	●

8. When the test operation is fully completed, normal operation will be possible after 5 minutes. Otherwise, refer to "Correcting after abnormal completion of the test operation" on page 197 to take actions for correcting the abnormality.

Correcting after abnormal completion of the test operation

The test operation is only completed if there is no malfunction code displayed on the remote control. In case of a displayed malfunction code, perform the following actions to correct the abnormality:

- Confirm the malfunction code on the remote control

Installation error	Error code	Remedial action
The stop valve of an outdoor unit is left closed.	<i>E3</i> <i>E4</i> <i>F3</i> <i>F6</i> <i>UF</i>	Open the stop valve.
The phases of the power to the outdoor units are reversed.	<i>U1</i>	Exchange two of the three phases (L1, L2, L3) to make a positive phase connection.
No power is supplied to an outdoor or indoor unit (including phase interruption).	<i>LC</i> <i>U1</i> <i>U4</i>	Check if the power wiring for the outdoor units are connected correctly.
Incorrect interconnections between units	<i>UF</i>	Check if the refrigerant line piping and the unit wiring are consistent with each other.
Refrigerant overcharge	<i>E3</i> <i>F6</i> <i>UF</i>	Recalculate the required amount of refrigerant from the piping length and correct the refrigerant charge level by recovering any excessive refrigerant with a refrigerant recovery machine.
Insufficient refrigerant	<i>E4</i> <i>F3</i>	Check if the additional refrigerant charge has been finished correctly. Recalculate the required amount of refrigerant from the piping length and add an adequate amount of refrigerant.
The added amount of refrigerant was not inputted after automatic charging.	<i>PF</i>	Availability of the leak detection function feature requires input of the additional refrigerant charge amount immediately after finishing the automatic charging. Refer to " 1.2.6.6 Procedure for inputting the additional refrigerant charge weight into the PC board" on page 189.
In case the test operation was interrupted or the unit was operating out of the instructed temperature range, the initial refrigerant detection has failed.	<i>U3</i>	In case the test operation was interrupted, perform the test operation again. In case the unit was operating out of the instructed temperature range, the unit can still be operated normally, but the leak detection function will not be available. Perform the test operation again within the instructed temperature range.

- After correcting the abnormality, press the **BS3 RETURN** button and reset the malfunction code.
- Carry out the test operation again and confirm that the abnormality is properly corrected.

1.2.6.8.5 Final check after installation

After all installation works are completed, operate the unit normally and check the following:

- Make sure the indoor units and outdoor unit are operating normally.
- Operate each indoor unit separately and make sure the corresponding outdoor unit is also operating properly.
- Check if cold or hot air is coming out from the indoor unit.
- Push the fan direction and fan strength buttons on the remote control to check if they are operating properly.



Note:

- Heating is not possible if the outdoor temperature is 24°C or higher. Refer to the operation manual.
- If a knocking sound is heard in the liquid compression of the compressor, stop the unit immediately and then energize the crankcase heater for a sufficient length of time before restarting the operation.
- Once stopped, the compressor will not restart in about 5 minutes, even if the ON/OFF button on the remote control is pushed.
- When the system operation is stopped by the remote control, the outdoor unit may continue operation for a maximum of 5 minutes.
- The outdoor fan may rotate at low speeds in the night-time low noise setting or the external low noise level setting is made; but this is not a malfunction.

1.2.6.8.6 Service mode operation



Note:

Do not shut off the power and do not reset the setting of mode 2 when vacuuming or recovering refrigerant. Otherwise the expansion valves will close making it impossible to vacuum the system or to recover the refrigerant.

Vacuumping method

At the first installation, this vacuuming is not required. It is required only for repair purposes.

1. When the unit is at standstill and under the setting mode 2, set the required function B (refrigerant recovery operation/vacuumping operation) to **ON** (ON).
 - The indoor unit, BS unit and the outdoor unit expansion valves will fully open.
 - The H1P LED is on and the remote control indicates **TEST** (test operation) and  (external control) and the operation will be prohibited.
2. Evacuate the system with a vacuum pump.
3. Press the **BS1 MODE** button and reset the setting mode 2.

Refrigerant recovery operation method

by a refrigerant reclaimer

1. When the unit is at standstill and under the setting mode 2, set the required function B (refrigerant recovery operation/vacuumping operation) to **ON** (ON).
 - The indoor unit, BS unit and the outdoor unit expansion valves will fully open.
 - The H1P LED is on and the remote control indicates **TEST** (test operation) and  (external control) and the operation will be prohibited.
2. Recover the refrigerant by a refrigerant reclaimer. For details, see the operation manual delivered with the refrigerant reclaimer.
3. Press the **BS1 MODE** button and reset the setting mode 2.

1.2.6.8.7 Additional refrigerant charging method

When the leak detection function is not required and the entire refrigerant quantity can not be charged through the liquid pipe stop valve service port with the unit not operating (refer to "Pre-charging" on page 184), make sure to charge the remaining charging quantity using the following procedure:

1. Turn the power of the indoor unit, the BS unit and the outdoor unit on.
2. Make sure to open the stop valves of the suction gas pipe, the high pressure/low pressure gas pipe and the liquid pipe completely.
3. Connect the refrigerant charge hose to the refrigerant charging port (for additional charging).
4. When the unit is not operating, push the **BS2 SET** button until the additional refrigerant charging operation function A in setting mode 2 can be defined (refer to "Setting the mode" on page 194), the H1P LED is on (☼).
5. The operation starts automatically.
The H2P LED will start flashing (⚡) and the messages "Test operation" and "Under centralized control" will display on the remote control.
6. After charging the specified quantity of refrigerant, press the **BS3 RETURN** button to stop the operation.
The operation will stop within 30 minutes.
 - If charging is not completed after 30 minutes, set and perform the additional refrigerant charging operation again.
 - If the additional refrigerant charging operation stops before the passing of 30 minutes, the system may be overcharged.



Never charge extra refrigerant.

7. Disconnect the refrigerant charge hose.
8. Perform " 1.2.6.7 Checks after adding refrigerant" as explained on page 190.

1.3 Operation when Power is Turned On

1.3.1 When Turning On Power First Time

The unit cannot be run for up to 12 minutes to automatically set the master power and address (indoor-outdoor address, etc.).

Status

Outdoor unit

Test lamp H2P Blinks
Can also be set during operation described above.

Indoor unit

If ON button is pushed during operation described above, the "UH" malfunction indicator blinks.
(Returns to normal when automatic setting is complete.)

1.3.2 When Turning On Power the Second Time and Subsequent

Tap the RESET button on the outdoor unit PC board. Operation becomes possible for about 2 minutes. If you do not push the RESET button, the unit cannot be run for up to 10 minutes to automatically set master power.

Status

Outdoor unit

Test lamp H2P Blinks
Can also be set during operation described above.

Indoor unit

If ON button is pushed during operation described above, the operation lamp lights but the compressor does not operate. (Returns to normal when automatic setting is complete.)

1.3.3 When an Indoor Unit or Outdoor Unit has been Added, or Indoor or Outdoor Unit PC Board has been Changed

Be sure to push and hold the RESET button for 5 seconds. If not, the addition cannot be recognized. In this case, the unit cannot be run for up to 12 minutes to automatically set the address (indoor-outdoor address, etc.)

Status

Outdoor unit

Test lamp H2P ON
Can also be set during operation described above.

Indoor unit

If ON button is pushed during operation described above, the "UH" or "U4" malfunction indicator blinks. (Returns to normal when automatic setting is complete.)

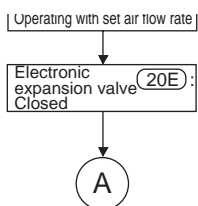

- *9. Fan operation
By setting the remote controller to Fan, the fan will operate with thermostat OFF in set temperature control operation mode.
- *10. Set wind direction
According to wind direction instruction from the remote controller, the wind direction is set to 100% horizontal while in heating operation.
- *11. Fan
According to fan speed instruction from the remote controller, the fan is put into operation in LL mode while in heating operation.

- *12. Wind direction
When the heating thermostat turns OFF, the wind direction will be set to 100% horizontal.
- *13. Hot start
If the condenser inlet temperature exceeds 34°C at the time of starting operation or after the completion of defrost operation, or until 3 minutes pass or Tc is above 52°C, hot starting will be conducted.
- *14. Thermostat status

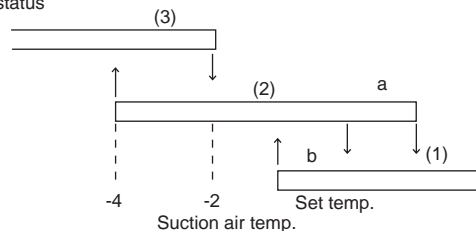

- *15. Outlet air temperature drop protection
When the set temperature is below 24°C or the electronic expansion valve opening is small, the protection will be activated.



Caution When the 400 volt power supply is applied to "N" phase by mistake, replace Inverter PC board (A2P) and control transformer (T1R, T2R) in switch box together.

2. Outdoor Unit PC Board Layout

Outdoor unit PC board

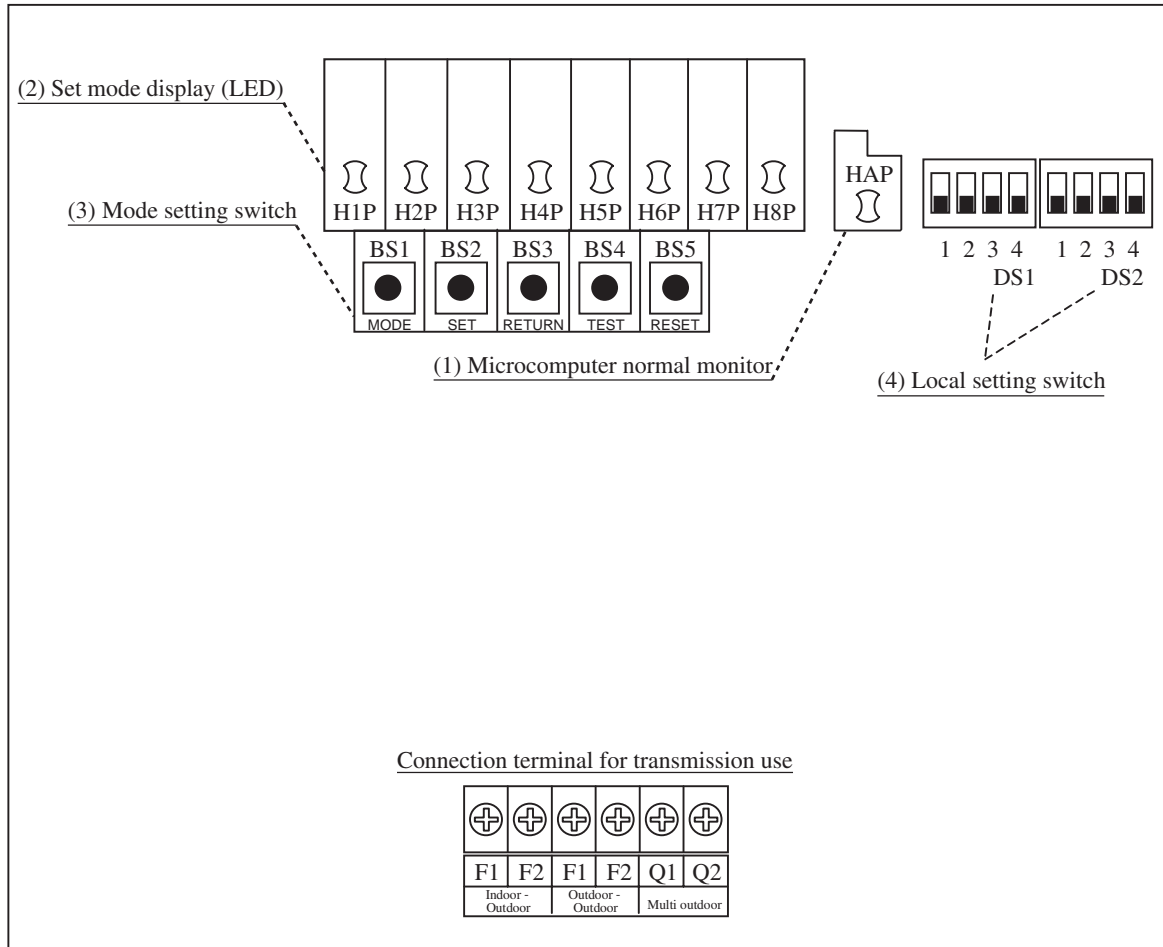

(V3054)

- (1) Microcomputer normal monitor
This monitor blinks while in normal operation, and turns on or off when a malfunction occurs.
- (2) Set mode display (LED)
LEDs display mode according to the setting.
- (3) Mode setting switch
Used to change mode.
- (4) Local setting switch
Used to make field settings.

3. Field Setting

3.1 Field Setting from Remote Control





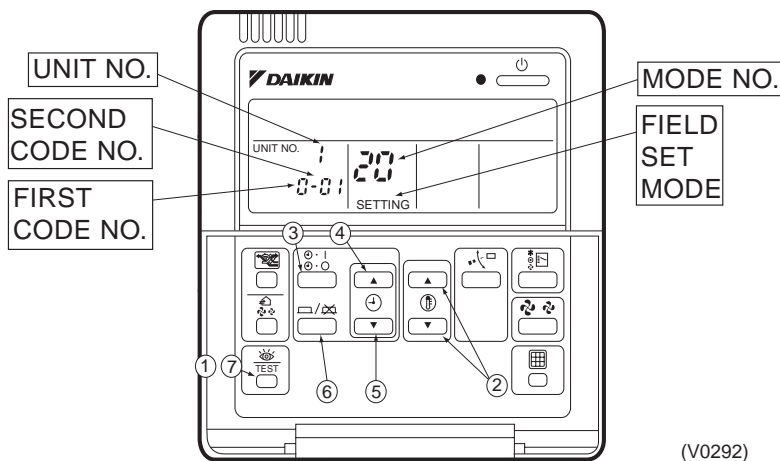

Individual function of indoor unit can be changed from the remote control. At the time of installation or after service inspection / repair, make the local setting in accordance with the following description.

Wrong setting may cause malfunction.

(When optional accessory is mounted on the indoor unit, setting for the indoor unit may be required to change. Refer to information in the option handbook.)

3.1.1 Wired Remote Control <BRC1C61, 62>



1. When in the normal mode, press the “” button for a minimum of four seconds, and the FIELD SET MODE is entered.
2. Select the desired MODE NO. with the “” button (②).
3. During group control, when setting by each indoor unit (mode No. 20, 22 and 23 have been selected), push the “” button (③) and select the INDOOR UNIT NO to be set. (This operation is unnecessary when setting by group.)
4. Push the “” upper button (④) and select FIRST CODE NO.
5. Push the “” lower button (⑤) and select the SECOND CODE NO.
6. Push the “” button (⑥) once and the present settings are SET.
7. Push the “” button (⑦) to return to the NORMAL MODE.

(Example)





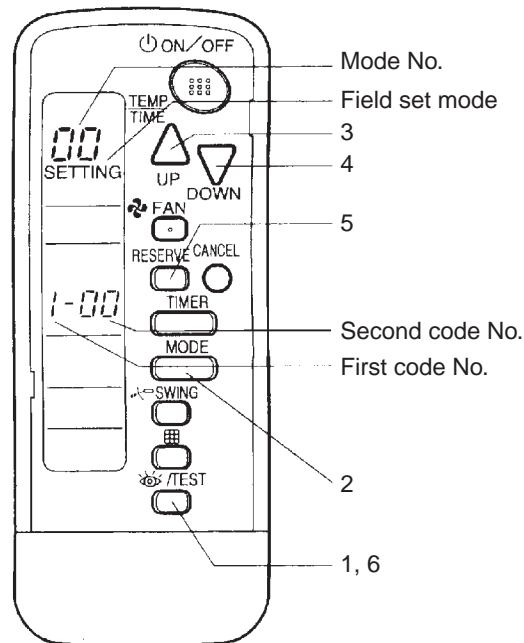

If during group setting and the time to clean air filter is set to FILTER CONTAMINATION, HEAVY, SET MODE NO. to “10” FIRST CODE NO. to “0”, and SECOND CODE NO. to “02”.

3.1.2 Wireless Remote Control - Indoor Unit

BRC7C type
BRC7E type
BRC4C type



(V2770)

1. When in the normal mode, push the “” button for 4 seconds or more, and operation then enters the “field set mode.”
2. Select the desired “mode No.” with the “” button.
3. Pushing the “” button, select the first code No.
4. Pushing the “” button, select the second code No.
5. Push the timer “” button and check the settings.
6. Push the “” button to return to the normal mode.

(Example)

When setting the filter sign time to “Filter Dirtiness-High” in all group unit setting, set the Mode No. to “10”, Mode setting No. to “0” and setting position No. to “02”.

3.1.3 Simplified Remote Control

BRC2A51
BRC2C51

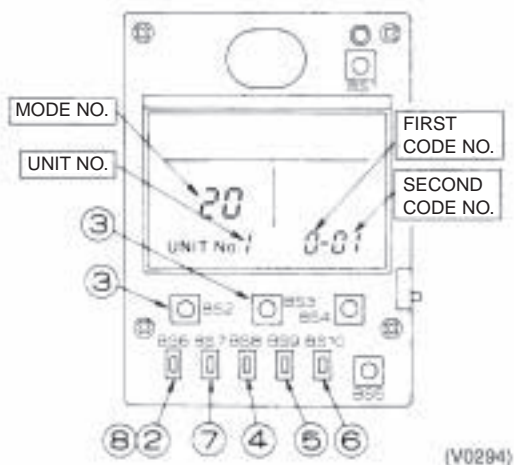

1. Remove the upper part of remote control.
2. When in the normal mode, press the [BS6] BUTTON (②) (field set), and the FIELD SET MODE is entered.
3. Select the desired MODE No. with the [BS2] BUTTON (③) (temperature setting ▲) and the [BS3] BUTTON (③) (temperature setting ▼).
4. During group control, when setting by each indoor unit (mode No. 20, 22, and 23 have been selected), push the [BS8] (④) BUTTON (unit No.) and select the INDOOR UNIT NO. to be set. (This operation is unnecessary when setting by group.)
5. Push the [BS9] BUTTON (⑤) (set A) and select FIRST CODE NO.
6. Push the [BS10] BUTTON (⑥) (set B) and select SECOND CODE NO.
7. Push the [BS7] BUTTON (⑦) (set/cancel) once and the present settings are SET.
8. Push the [BS6] BUTTON (⑧) (field set) to return to the NORMAL MODE.
9. (Example) If during group setting and the time to clean air filter is set to FILTER CONTAMINATION - HEAVY, SET MODE NO. to "10", FIRST CODE NO. to "0", and SECOND CODE NO. to "02".

3.1.4 Setting Contents and Code No. – VRV Indoor unit

VRV system indoor unit settings	Mode No. Note 2	Setting Switch No.	Setting Contents	Second Code No.(Note 3)								Details No	
				01		02		03		04			
10(20)	0		Filter contamination heavy/light (Setting for display time to clean air filter) (Sets display time to clean air filter to half when there is heavy filter contamination.)	Super long life filter	Light	Approx. 10,000 hrs.	Heavy	Approx. 5,000 hrs.	—		—		(1)
				Long life filter		Approx. 2,500 hrs.		Approx. 1,250 hrs.					
				Standard filter		Approx. 200 hrs.		Approx. 100 hrs.					
	1		Long life filter type	Long life filter		Super long life filter		—		—		(2)	
2		Thermostat sensor in remote control	remote control + Body thermostat		Only body thermostat		Only remote control thermostat		—		(3)		
3		Display time to clean air filter calculation (Set when filter sign is not to be displayed.)	Display		No display		—		—		(4)		
12(22)	0		Optional accessories output selection (field selection of output for adaptor for wiring)	Indoor unit turned ON by thermostat		—		Operation output		Malfunction output		(5)	
	1		ON/OFF input from outside (Set when ON/OFF is to be controlled from outside.)	Forced OFF		ON/OFF control		External protection device input		—		(6)	
	2		Thermostat differential changeover (Set when remote sensor is to be used.)	1°C		0.5°C		—		—		(7)	
	3		Air flow setting when heating thermostat is OFF	LL		Set fan speed		—		—		(8)	
	4		Automatic mode differential (automatic temperature differential setting for VRV system heat recovery series cool/heat)	01:0	02:1	03:2	04:3	05:4	06:5	07:6	08:7	—	
	5		Power failure automatic reset	Not equipped		Equipped		—		—		(9)	
	6		Air flow setting when Cooling thermostat is OFF	LL		Set fan speed		—		—		(10)	
13(23)	0		Setting of normal air flow	N		H		S		—		(11)	
	1		Selection of air flow direction (Set when a blocking pad kit has been installed.)	F (4 directions)		T (3 directions)		W (2 directions)		—		(12)	
	3		Operation of downward flow flap: Yes/No	Equipped		Not equipped		—		—		(13)	
	4		Field set air flow position setting	Draft prevention		Standard		Ceiling Soiling prevention		—		(14)	
	5		Setting of static pressure selection	Standard		High static pressure		—		—		(15)	
15(25)	1		Thermostat OFF excess humidity	Not equipped		Equipped		—		—		(16)	
	2		Direct duct connection (when the indoor unit and heat reclaim ventilation unit are connected by duct directly.) *Note 6	Not equipped		Equipped		—		—		(17)	
	3		Drain pump humidifier interlock selection	Not equipped		Equipped		—		—		(18)	
	5		Field set selection for individual ventilation setting by remote control	Not equipped		Equipped		—		—		(19)	



- Notes :**
- Settings are made simultaneously for the entire group, however, if you select the mode No. inside parentheses, you can also set by each individual unit. Setting changes however cannot be checked except in the individual mode for those in parentheses.
 - The mode numbers inside parentheses cannot be used by wireless remote controls, so they cannot be set individually. Setting changes also cannot be checked.
 - Marked are factory set.
 - Do not make settings other than those described above. Nothing is displayed for functions the indoor unit is not equipped with.
 - “88” may be displayed to indicate the remote control is resetting when returning to the normal mode.
 - If the setting mode to “Equipped”, heat reclaim ventilation fan conducts the fan residual operation by linking to indoor unit.

3.1.5 Applicable Range of Field Setting

	Ceiling mounted cassette				Slim concealed ceiling unit	Concealed ceiling unit (small)	Concealed ceiling unit	Concealed ceiling unit (large)	Ceiling suspended unit	Wall mounted unit	Floor standing unit	Concealed floor standing unit	4-way blow ceiling suspended unit
	Round-flow	4-way blow	2-way blow	Corner type									
	FXFQ	FXZQ	FXCQ	FXKQ									
Filter sign	○	○	○	○	○	○	○	○	○	○	○	○	○
Ultra long life filter sign	○	○	○	—	—	—	—	—	—	—	—	—	—
remote control thermostat sensor	○	○	○	○	○	○	○	○	○	○	○	○	○
Set fan speed when thermostat OFF	○	○	○	○	○	○	○	○	○	○	○	○	○
Air flow adjustment Ceiling height	○	—	—	—	—	—	—	—	○	—	—	—	○
Air flow direction	○	○	—	—	—	—	—	—	—	—	—	—	○
Air flow direction adjustment (Down flow operation)	—	—	—	○	—	—	—	—	—	—	—	—	—
Air flow direction adjustment range	○	○	○	○	—	—	—	—	—	—	—	—	—
Field set fan speed selection	○	—	—	—	○*1	—	—	—	○	—	—	—	—
Discharge air temp. (Cooling)	—	—	—	—	—	—	—	—	—	—	—	—	—
Discharge air temp. (Heating)	—	—	—	—	—	—	—	—	—	—	—	—	—

*1 Static pressure selection

3.1.6 Detailed Explanation of Setting Modes

(1) Filter Sign Setting

If switching the filter sign ON time, set as given in the table below.

Set Time

Setting	Filter Specs.	Standard	Long Life	Ultra Long Life Filter
Contamination Light		200 hrs.	2,500 hrs.	10,000 hrs.
Contamination Heavy		100 hrs.	1,250 hrs.	5,000 hrs.

(2) Ultra-Long-Life Filter Sign Setting

When a Ultra-long-life filter is installed, the filter sign timer setting must be changed.

Setting Table

Mode No.	Setting Switch No.	Setting Position No.	Setting
10 (20)	1	01	Long-Life Filter
		02	Ultra-Long-Life Filter (1)
		03	—

(3) Selection of Thermistor

Select the thermistor to control room temperature.

Mode No.	First Code No.	Second Code No.	Thermistor that controls room temperature
10 (20)	2	01	Indoor air thermistor for remote control and suction air thermistor for indoor unit
		02	Suction air thermistor for indoor unit
		03	Thermistor for remote control

The factory setting for the Second Code No. is "01" and room temperature is controlled by the indoor unit suction air thermistor and remote control thermistor.

When the Second Code No. is set to "02", room temperature is controlled by the suction air thermistor.

When the Second Code No. is set to "03", room temperature is controlled by the remote control thermistor.

(4) "Filter Cleaning" Displayed or Not Displayed

Whether or not to display "Filter Cleaning" after operation of certain duration can be selected.

Mode No.	First Code No.	Second Code No.	"Filter Cleaning" display
10 (20)	3	01	Display
		02	No display

(5) Optional Output Switching

Using this setting, "operation output signal" and "abnormal output signal" can be provided.

Output signal is output between terminals K1 and K2 of "customized wiring adapter," an optional accessory.

Mode No.	First Code No.	Second Code No.	Remarks
12 (22)	0	01	Indoor unit thermostat ON/OFF signal is provided.
		03	Output linked with "Start/Stop" of remote control is provided.
		04	In case of "Malfunction Display" appears on the remote control, output is provided.

(6) External ON/OFF input

This input is used for "ON / OFF operation" and "Protection device input" from the outside. The input is performed from the T1-T1 terminal of the operation terminal block (X1A) in the electric component box.

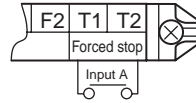

Setting Table

Mode No.	Setting Switch No.	Setting Position No.	Operation by input of the signal A
12 (22)	1	01	ON: Forced stop (prohibition of using the remote control) OFF: Permission of using the remote control
		02	OFF → ON: Permission of operation ON → OFF: Stop
		03	ON: Operation OFF: The system stops, then the applicable unit indicates "A0". The other indoor units indicate "U9".

(7) Thermostat Switching

Differential value during thermostat ON/OFF control can be changed. (For details, refer to "6.4 Thermostat Control while in Normal Operation" on page 149.)

Mode No.	First Code No.	Second Code No.	Differential value
12(22)	2	01	1°C
		02	0.5°C

(8) Air Flow Setting When Heating Thermostat is OFF

This setting is used to set air flow when heating thermostat is OFF.

* When thermostat OFF air flow volume up mode is used, careful consideration is required before deciding installation location. During heating operation, this setting takes precedence over "(7) Fan Stop When Thermostat is OFF."

Mode No.	First Code No.	Second Code No.	Contents
12 (22)	3	01	LL air flow
		02	Preset air flow

(9) Setting of operation mode to "AUTO"

This setting makes it possible to change differential values for mode selection while in automatic operation mode.

Mode No.	Setting switch No.	Setting position No.							
		01	02	03	04	05	06	07	08
12 (22)	4	0°C	1°C	2°C	3°C	4°C	5°C	6°C	7°C

The automatic operation mode setting is made by the use of the "Operation Mode Selector" button.

(10) Auto Restart after Power Failure Reset

For the air conditioners with no setting for the function (same as factory setting), the units will be left in the stop condition when the power supply is reset automatically after power failure reset or the main power supply is turned on again after once turned off. However, for the air conditioners with the setting, the units may start automatically after power failure reset or the main power supply turned on again (return to the same operation condition as that of before power failure).

For the above reasons, when the unit is set enabling to utilize "Auto restart function after power failure reset", utmost care should be paid for the occurrence of the following situation.



- Caution**
- 1. The air conditioner starts operation suddenly after power failure reset or the main power supply turned on again. Consequently, the user might be surprised (with question for the reason why).**
 - 2. In the service work, for example, turning off the main power switch during the unit is in operation, and turning on the switch again after the work is completed start the unit operation (the fan rotates).**

(11) Air Flow When Cooling Thermostat is OFF

This is used to set air flow to "LL air flow" when cooling thermostat is OFF.

Mode No.	First Code No.	Second Code No.	Contents
12 (22)	6	01	LL air flow
		02	Preset air flow

(12) Setting of Normal Air Flow

Make the following setting according to the ceiling height. The setting position No. is set to "01" at the factory.

■ **In the Case of FXAQ, FXHQ**

Mode No.	Setting Switch No.	Setting Position No.	Setting
13(23)	0	01	Wall-mounted type: Standard
		02	Wall-mounted type: Slight increase
		03	Wall-mounted type: Normal increase

■ **In the Case of FXFQ25~80**

Mode No.	First code No.	Second code No.	Setting	Ceiling height		
				4-way Outlets	3-way Outlets	2-way Outlets
13 (23)	0	01	Standard (N)	Lower than 2.7 m	Lower than 3.0 m	Lower than 3.5 m
		02	High Ceiling (H)	Lower than 3.0 m	Lower than 3.3 m	Lower than 3.8 m
		03	Higher Ceiling (S)	Lower than 3.5 m	Lower than 3.5 m	—

■ **In the Case of FXFQ100~125**

Mode No.	First code No.	Second code No.	Setting	Ceiling height		
				4-way Outlets	3-way Outlets	2-way Outlets
13 (23)	0	01	Standard (N)	Lower than 3.2 m	Lower than 3.6 m	Lower than 4.2 m
		02	High Ceiling (H)	Lower than 3.6 m	Lower than 4.0 m	Lower than 4.2 m
		03	Higher Ceiling (S)	Lower than 4.2 m	Lower than 4.2 m	—

■ In the Case of FXUQ71~125

Mode No.	First code No.	Second code No.	Setting	Ceiling height		
				4-way Outlets	3-way Outlets	2-way Outlets
13 (23)	0	01	Standard (N)	Lower than 2.7 m	Lower than 3.0 m	Lower than 3.5 m
		02	High Ceiling (H)	Lower than 3.0 m	Lower than 3.5 m	Lower than 3.8 m
		03	Higher Ceiling (S)	Lower than 3.5 m	Lower than 3.8 m	—

(13) Air Flow Direction Setting

Set the air flow direction of indoor units as given in the table below. (Set when optional air outlet blocking pad has been installed.) The second code No. is factory set to "01."

Setting Table

Mode No.	First Code No.	Second Code No.	Setting
13 (23)	1	01	F : 4-direction air flow
		02	T : 3-direction air flow
		03	W : 2-direction air flow

(14) Operation of Downward Flow Flap: Yes/No

Only the model FXKQ has the function.

When only the front-flow is used, sets yes/no of the swing flap operation of down-flow.

Setting Table

Mode No.	First Code No.	Second Code No.	Setting
13 (23)	3	01	Down-flow operation: Yes
		02	Down-flow operation: No

(15) Setting of Air Flow Direction Adjustment Range

Make the following air flow direction setting according to the respective purpose.



(S2537)

Setting Table

Mode No.	First Code No.	Second Code No.	Setting
13 (23)	4	01	Upward (Draft prevention)
		02	Standard
		03	Downward (Ceiling soiling prevention)

* Some indoor unit models are not equipped with draft prevention (upward) function.

(16) Setting of the Static Pressure Selection (for FXDQ model)

Model No.	First Code No.	Second Code No.	External static pressure
13 (23)	5	01	Standard (15Pa)
		02	High static pressure (44Pa)

(17) Humidification When Heating Thermostat is OFF

Setting to "Humidification Setting" turns ON the humidifier if suction temperature is 20°C or above and turns OFF the humidifier if suction temperature is 18°C or below when the heating thermostat is OFF.

Mode No.	First Code No.	Second Code No.	Setting
15 (25)	1	01	—
		02	Setting of humidifier

(18) Setting of Direct Duct Connection

This is used when "fresh air intake kit equipped with fan" is connected. The indoor fan carries out residual operation for one minute after the thermostat is stopped. (For the purpose of preventing dust on the air filter from falling off.)

Mode No.	First Code No.	Second Code No.	Contents
15 (25)	2	01	Without direct duct connection
		02	With direct duct connection equipped with fan

(19) Interlocked Operation between Humidifier and Drain Pump

This is used to interlock the humidifier with the drain pump. When water is drained out of the unit, this setting is unnecessary.

Mode No.	First Code No.	Second Code No.	Contents
15 (25)	3	01	Individual operation of humidifier
		02	Interlocked operation between humidifier and drain pump

(20) Individual Setting of Ventilation

This is set to perform individual operation of heat reclaim ventilation using the remote control/central unit when heat reclaim ventilation is built in.
(Switch only when heat reclaim ventilation is built in.)





Mode No.	First Code No.	Second Code No.	Contents
15 (25)	5	01	—
		02	Individual operation of ventilation

3.1.7 Centralized Control Group No. Setting

BRC1C Type

In order to conduct the central remote control using the central remote control and the unified ON/OFF controller, Group No. settings should be made by group using the operating remote control.

Make Group No. settings for central remote control using the operating remote control.

1. While in normal mode, press and hold the “” switch for a period of four seconds or more to set the system to “Field Setting Mode”.
2. Select the MODE No. “00” with the “” button.
3. Use the “” button to select the group No. for each group.
(Group numbers increase in the order of 1-00, 1-01, ... 1-15, 2-00, ... 4-15.)
4. Press “” to set the selected group No.
5. Press “” to return to the NORMAL MODE.

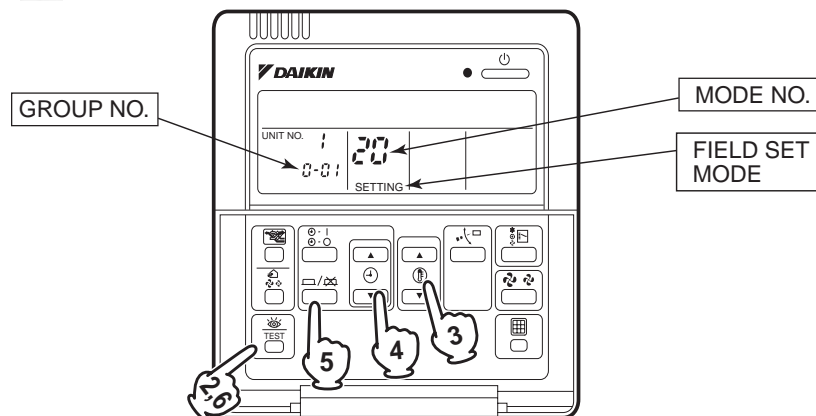







Note:

- For wireless remote control, see the following.
- For setting group No. of HRV and wiring adaptor for other air conditioners, etc., refer to the instruction manual attached.

NOTICE

Enter the group No. and installation place of the indoor unit into the attached installation table. Be sure to keep the installation table with the operation manual for maintenance.

BRC7C Type BRC7E Type BRC4C Type

- Group No. setting by wireless remote control for centralized control
1. When in the normal mode, push “” button for 4 seconds or more, and operation then enters the “field set mode.”
 2. Set mode No. “00” with “” button.
 3. Set the group No. for each group with “” “” button (advance/backward).
 4. Enter the selected group numbers by pushing “” button.
 5. Push “” button and return to the normal mode.

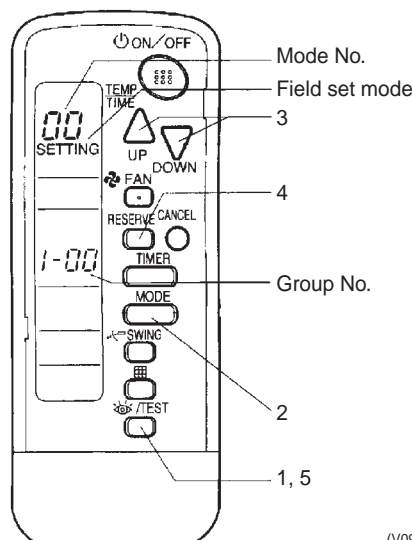

(V0916)

Group No. Setting Example

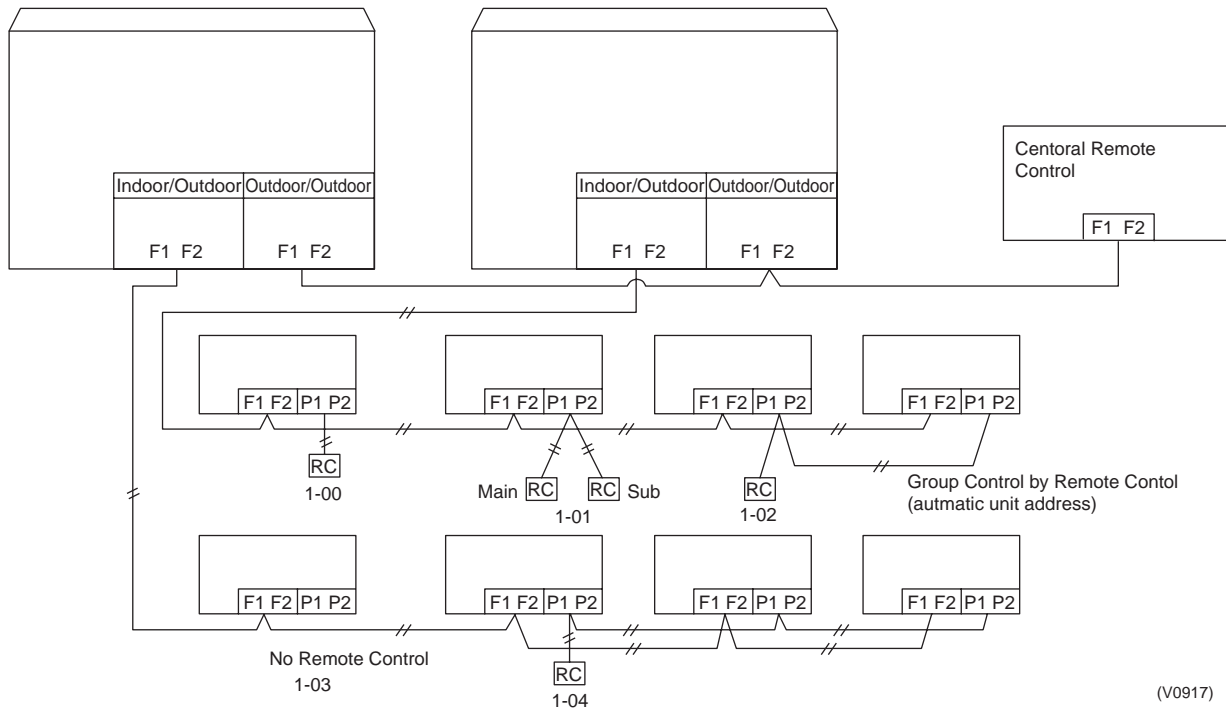

Caution When turning the power supply on, the unit may often not accept any operation while "88" is displaying after all indications were displayed once for about 1 minute on the liquid crystal display. This is not an operative fault.

3.1.8 Setting of Operation Control Mode from Remote Control (Local Setting)

The operation control mode is compatible with a variety of controls and operations by limiting the functions of the operation remote control. Furthermore, operations such as remote control ON/OFF can be limited in accordance with the combination conditions. (Refer to information in the next page.)

Central remote control is normally available for operations. (Except when centralized monitor is connected)

3.1.9 Contents of Control Modes

Twenty modes consisting of combinations of the following five operation modes with temperature and operation mode setting by remote control can be set and displayed by operation modes 0 through 19.

- ◆ ON/OFF control impossible by remote control
Used when you want to turn on/off by central remote control only.
(Cannot be turned on/off by remote control.)
- ◆ OFF control only possible by remote control
Used when you want to turn on by central remote control only, and off by remote control only.
- ◆ Centralized
Used when you want to turn on by central remote control only, and turn on/off freely by remote control during set time.
- ◆ Individual
Used when you want to turn on/off by both central remote control and remote control.
- ◆ Timer operation possible by remote control
Used when you want to turn on/off by remote control during set time and you do not want to start operation by central remote control when time of system start is programmed.

How to Select Operation Mode

Whether operation by remote control will be possible or not for turning on/off, controlling temperature or setting operation mode is selected and decided by the operation mode given on the right edge of the table below.

Example

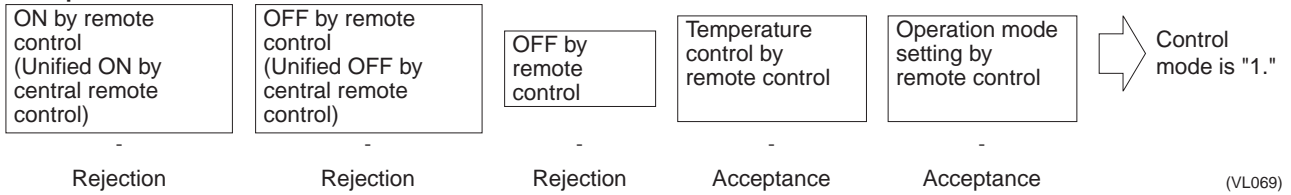

(VL069)

Control mode	Control by remote control					Control mode			
	Operation		OFF	Temperature control	Operation mode setting				
	Unified operation, individual operation by central remote control, or operation controlled by timer	Unified OFF, individual stop by central remote control, or timer stop							
ON/OFF control impossible by remote control	Rejection (Example)	Rejection (Example)	Rejection (Example)	Rejection	Acceptance	0			
OFF control only possible by remote control				Acceptance (Example)	Rejection	10			
Centralized	Acceptance	Acceptance	Acceptance	Acceptance (Example)	Acceptance (Example)	1(Example)			
Individual				Rejection	Rejection	11			
Timer operation possible by remote control				Acceptance (During timer at ON position only)	Acceptance (During timer at ON position only)	Acceptance	Rejection	Acceptance	2
							Acceptance	Rejection	12
Centralized	Acceptance	Acceptance	Acceptance	Acceptance	Acceptance	3			
				Rejection	Rejection	13			
Individual	Acceptance	Acceptance	Acceptance	Rejection	Acceptance	4			
				Acceptance	Rejection	14			
Timer operation possible by remote control	Acceptance (During timer at ON position only)	Acceptance (During timer at ON position only)	Acceptance	Acceptance	Acceptance	5			
				Rejection	Rejection	15			
Centralized	Acceptance	Acceptance	Acceptance	Rejection	Acceptance	6			
				Acceptance	Rejection	16			
Individual	Acceptance	Acceptance	Acceptance	Acceptance	Acceptance	7 *1			
				Rejection	Rejection	17			
Timer operation possible by remote control	Acceptance (During timer at ON position only)	Acceptance (During timer at ON position only)	Acceptance	Rejection	Acceptance	8			
				Acceptance	Rejection	18			
Centralized	Acceptance	Acceptance	Acceptance	Acceptance	Acceptance	9			
				Rejection	Rejection	19			

Do not select "timer operation possible by remote control" if not using a remote control. Operation by timer is impossible in this case.

*1. Factory setting

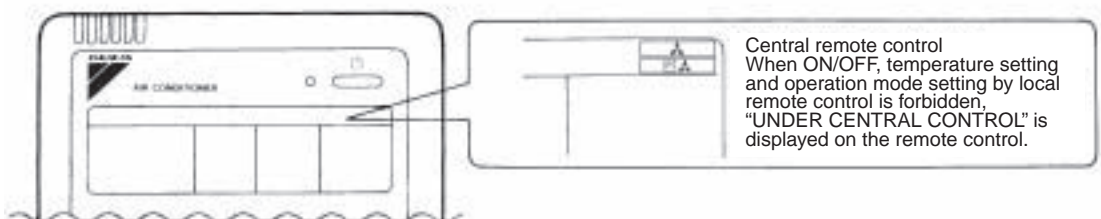

3.2 Field Setting from Outdoor Unit

3.2.1 Field Setting from Outdoor Unit

■ List of Field Setting Items

This following section indicates the list of field setting items. For the lists of dip switch contents, Setting mode 1, and Setting mode 2, refer to information in tables shown on the following page onward.

For setting items of (*1), refer to detailed information provided on page 232 onward.

Setting item		Content and objective of setting	Overview of setting procedure	Reference page	
Function setting	2	A. Use external input to step down the upper limit of the fan (factory set to Step 8), providing low noise level. (1) Mode 1: Step 5 or lower (2) Mode 2: Step 4 or lower (3) Mode 3: Step 3 or lower	■ Use the "External control adaptor for outdoor unit". Set to "External control adaptor for outdoor unit" with No. 12 of "Setting mode 2" and select the mode with No. 25. If necessary, set the "Capacity priority setting" to ON with No. 29.	231~235	
		B. The low noise operation aforementioned is enabled in nighttime automatic low noise operation mode. Start time: Possible to select in the range of 20:00 to 24:00 hours. End time: Possible to select in the range of 06:00 to 08:00 hours. (Use the said time as a guide since the start time and the end time are estimated according to outdoor temperatures.)	■ Make this setting while in "Setting mode 2". Select a mode with No. 22 of "Setting mode 2". Select the start time with No. 26 and the end time with No. 27. If necessary, set the "Capacity priority setting" to ON with No. 29.	231~235	
	3	Setting of demand operation (*1)	■ Used to place limits on the compressor operating frequency to control the upper limit of power consumption. (1) Mode 1 of Demand 1: 60% or less of rating (2) Mode 2 of Demand 1: 70% or less of rating (3) Mode 3 of Demand 1: 80% or less of rating (4) Demand 2: 40% or less of rating	■ For setting with the use of "external control adapter": Set the system to "External control adaptor for outdoor unit" with No. 12 of "Setting mode 2" and select the mode with No. 30.	231~235
			■ For setting only in "Setting mode 2": Set the system to Normal demand mode with No. 32 of "Setting mode 2" and select the mode with No. 30.	231~235	
	4	Setting of AirNet address	■ Used to make address setting with AirNet connected.	■ Set the AirNet to an intended address using binary numbers with No. 13 of "Setting mode 2".	224~227
	6	Setting of high static pressure	■ Make this setting to operate a system with diffuser duct while in high static pressure mode. (Use this setting mode when shields are installed on upper floors or balconies.) * In order to mount the diffuser duct, remove the cover from the outdoor unit fan.	■ Set No. 18 of "Setting mode 2" to ON.	224~227
	7	Prevention of minute heating operation by heating thermostat OFF unit or non-heating-operation unit	■ Make this setting to prevent a rise in room temperature due to minute heating capacity generated by heating thermostat OFF unit or non-heating-operation unit while in heating operation.	■ Set the Setting item No. 41 of "Setting mode 2" to heating thermostat OFF unit or non-heating-operation unit. (Overseas unit: Default set to "ON")	224~227
	8	Setting of BS Cool-Heat selection control time	■ Make this setting to shorten the BS Cool-Heat selection control time.	■ Set the Setting item No. 42 of "Setting mode 2" to "ON".	224~227

Setting item		Content and objective of setting	Overview of setting procedure	Reference page	
Service setting	1	Indoor unit fan forced H operation	<ul style="list-style-type: none"> Used to operate the indoor unit in the stopped state in forced H operation mode. 	<ul style="list-style-type: none"> Set No. 5 of "Setting mode 2" to indoor unit forced fan H. 	224~227
	2	Indoor unit forced operation	<ul style="list-style-type: none"> Used to operate the indoor unit in forced operation mode. 	<ul style="list-style-type: none"> Set No. 6 of "Setting mode 2" to indoor unit forced operation mode. 	224~227
	3	Change of targeted evaporating temperature (in cooling)	<ul style="list-style-type: none"> In cooling operation, used to change the targeted evaporating temperature for compressor capacity control. 	<ul style="list-style-type: none"> Select high side or low side with No. 8 of "Setting mode 2". 	224~227
	4	Change of targeted condensing temperature (in heating)	<ul style="list-style-type: none"> In heating operation, used to change the targeted condensing temperature for compressor capacity control. 	<ul style="list-style-type: none"> Select high side or low side with No. 9 of "Setting mode 2". 	224~227
	5	Setting of defrost selection	<ul style="list-style-type: none"> Used to change a temperature at which the defrost operation is initiated, thus making the initiation easy or hard. 	<ul style="list-style-type: none"> Select fast side or slow side with No. 10 of "Setting mode 2". 	224~227
	6	Setting of sequential startup	<ul style="list-style-type: none"> Used to start units not in sequence but simultaneously. 	<ul style="list-style-type: none"> Set No. 11 of "Setting mode 2" to NONE. 	224~227
	7	Emergency operation (*1)	<ul style="list-style-type: none"> If the compressor has a failure, used to prohibit the operation of outdoor unit(s) concerned and to conduct emergency operation of the system only with operable or outdoor unit(s). 	<ul style="list-style-type: none"> Make this setting while in "Setting mode 2". For system with multiple outdoor units: Set with No. 38, 39, or 40. 	239~242
	8	Additional refrigerant charging (*1)	<ul style="list-style-type: none"> If a necessary amount of refrigerant cannot be charged due to the stop of outdoor unit, operate the outdoor unit and then refill refrigerant. 	<ul style="list-style-type: none"> Set No. 20 of "Setting mode 2" to ON and then charge refrigerant. 	165~170
	9	Refrigerant recovery mode (*1)	<ul style="list-style-type: none"> Used to recover refrigerant on site. With operations of indoor and outdoor units prohibited, open the outdoor/indoor expansion valve fully while indoor/outdoor operation is prohibited and turn ON some of the solenoid valves. 	<ul style="list-style-type: none"> Set No. 21 of "Setting mode 2" to ON. 	237
	10	Vacuumping mode (*1)	<ul style="list-style-type: none"> Used to conduct vacuuming on site. Open the outdoor/indoor expansion valve fully while indoor/outdoor operation is prohibited and turn ON some of the solenoid valves. Use a vacuum pump to conduct vacuuming. 	<ul style="list-style-type: none"> Set No. 21 of "Setting mode 2" to ON. 	238
	11	ENECUT test operation	<ul style="list-style-type: none"> Used to forcedly turn ON the ENECUT. (Be noted this mode is not functional with the indoor unit remote control turned ON.) 	<ul style="list-style-type: none"> Set No. 24 of "Setting mode 2" to ON. 	224~227
	12	Power transistor check mode	<ul style="list-style-type: none"> Used for the troubleshooting of DC compressors. Inverter waveform output makes it possible to judge whether a malfunction results from the compressor or the PC board. 	<ul style="list-style-type: none"> Set No. 28 of "Setting mode 2" to ON. 	224~227
	13	Setting of model with spare PC board	<ul style="list-style-type: none"> In order to replace the PC board by a spare one, be sure to make model setting. 	<ul style="list-style-type: none"> For this setting, set the DS2-2, -3, and-4 switches on the PC board to the model concerned. 	217~220

For setting items of (*1), refer to detailed information provided on page 223 onward.

3.2.2 Setting by Dip Switches

(1) Factory setting of initial PC board.

Do not make any changes in all factory settings of the DIP switches on the control PC board.

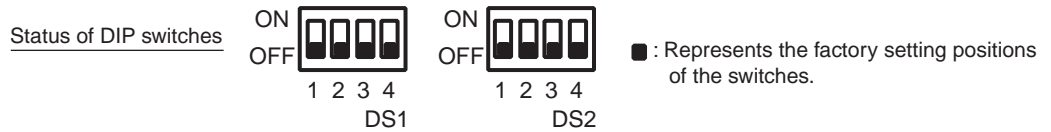

Setting at replacement by spare PC board



Caution DIP switch Setting after changing the main PC board(A1P) to spare parts PC board

After the replacement by the spare PC board, be sure to make settings shown below. When you change the main PC board(A1P) to spare parts PC board, please carry out the following setting.



DIP Switch Detail

DS No.	Item	Contents					
DS1-2	Power supply specification	ON	200V class (220V)				
		OFF (Factory setting of spare PC board)	400V class (380V)				
DS1-3 Except Multiple use	Cooling only/Heat-pump setting	ON	Cooling only setting				
		OFF (Factory setting of spare PC board)	Heat pump setting				
DS1-4	Unit allocation setting	ON	Make the following settings according to allocation of unit. (All models are set to OFF at factory.)				
DS2-1		OFF (Factory setting of spare PC board)	Multiple use Single use (Main)	Single use (sab)	Domestic Japan	Overseas General	Europe
			DS1-4	DS1-3	OFF	OFF	ON
DS2-1		DS2-1	DS1-4	OFF	ON	OFF	
DS2-2	Model setting	Make the following settings according to models of outdoor units. (All models are set to OFF at factory.) * Refer to following pages for setting detail.					
DS2-3							
DS2-4							

* For detail of the setting procedure, refer to information on the following pages. While the PC board assembly is replaced, the "U3" malfunction (Test run not carried out yet) code is displayed. In this case, carry out the test run again. If the "PJ", "UA", or "U7" malfunction code is displayed, recheck for DIP switch settings. After the completion of rechecking for the settings, turn ON the power supply again.

“Detail of DS1-1~4, DS2-1~4 setting”

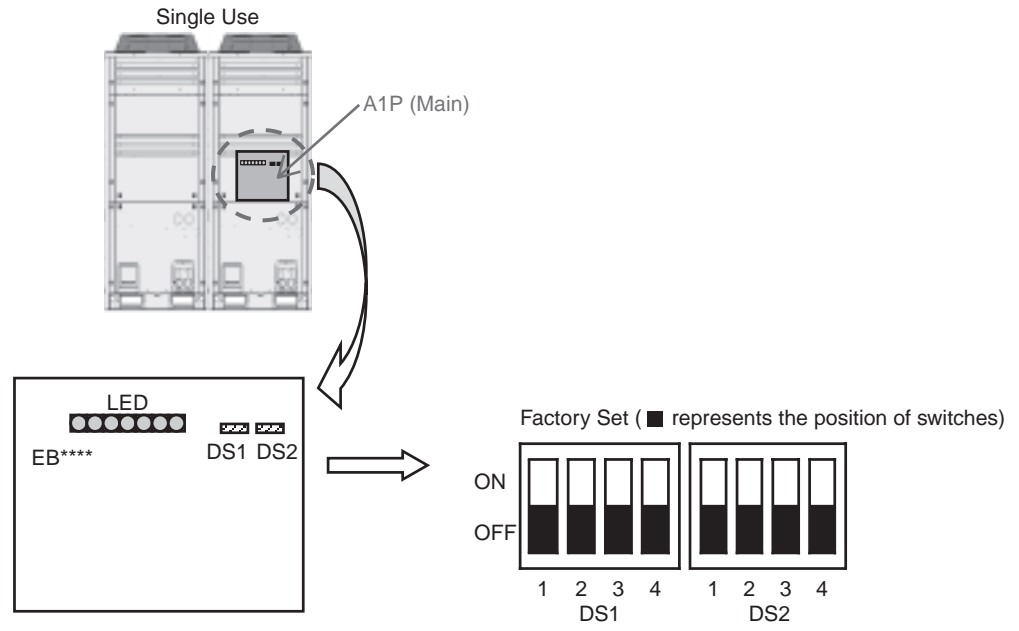

Allocation	Application model	Setting method (■ represents the position of switches)		
For Europe	HEAT RECOVERY(8HP) REYQ8P8Y1B	ON OFF	 DS1 DS2	Set DS1-4 and DS2-3 to ON.
	HEAT RECOVERY(10HP) REYQ10P8Y1B	ON OFF	 DS1 DS2	Set DS1-4 to ON.
	HEAT RECOVERY(12HP) REYQ12P8Y1B	ON OFF	 DS1 DS2	Set DS1-4 and DS2-2 to ON.
	HEAT RECOVERY(14HP) REYQ14P8Y1B	ON OFF	 DS1 DS2	Set DS1-3, DS1-4 and DS2-2 to ON.
	HEAT RECOVERY(16HP) REYQ16P8Y1B	ON OFF	 DS1 DS2	Set DS1-3, DS1-4 and DS2-3 to ON.

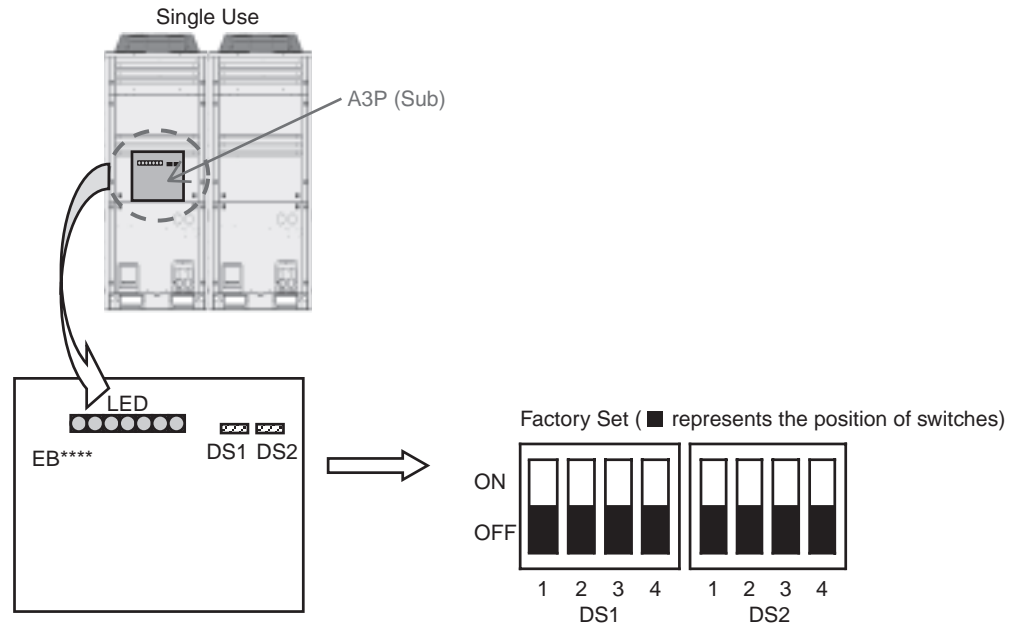

Allocation	Application model	Setting method (■ represents the position of switches)		
For Europe	HEAT RECOVERY(8HP) REYQ8PY1B	ON	DS1 DS2	Set DS1-3 and DS2-2 to ON.
	HEAT RECOVERY(10HP) REYQ10PY1B	ON	DS1 DS2	Set DS1-3 and DS2-2 to ON.
	HEAT RECOVERY(12HP) REYQ12PY1B	ON	DS1 DS2	Set DS1-3 and DS2-2 to ON.
	HEAT RECOVERY(14HP) REYQ14PY1B	ON	DS1 DS2	Set DS1-3, DS2-1 and DS2-4 to ON.
	HEAT RECOVERY(16HP) REYQ16PY1B	ON	DS1 DS2	Set DS1-3, DS2-1 and DS2-3 to ON.

A

Multiple Type

Allocation	Application model	Setting method (■ represents the position of switches)		
For Europe	HEAT RECOVERY(8HP) REMQ8P8Y1B	 ON OFF	 ON OFF	Set DS1-4, DS2-2 and DS2-3 to ON.
	HEAT RECOVERY(10HP) REMQ10P8Y1B	 ON OFF	 ON OFF	Set DS1-4 and DS2-4 to ON.
	HEAT RECOVERY(12HP) REMQ12P8Y1B	 ON OFF	 ON OFF	Set DS1-4, DS2-2 and DS2-4 to ON.
	HEAT RECOVERY(14HP) REMQ14P8Y1B	 ON OFF	 ON OFF	Set DS1-4, DS2-3 and DS2-4 to ON.
	HEAT RECOVERY(16HP) REMQ16P8Y1B	 ON OFF	 ON OFF	Set DS1-4, DS2-2, DS2-3 and DS2-4 to ON.

3.2.3 Setting by Push Button Switches

The following settings are made by push button switches on PC board.
 In case of multi-outdoor unit system, various items should be set with the master unit.
 (Setting with the slave unit is disabled.)

The master unit and slave unit can be discriminated with the LED display as shown below.

LED display

		MODE H1P	TEST H2P	COOL/HEAT select			Low noise H6P	Demand H7P	Multi; H8P
				IND H3P	MASTER H4P	SLAVE H5P			
Single-outdoor-unit system		●	●	☀	●	●	●	●	●
Outdoor-multi system	Master	●	●	☀	●	●	●	●	☀
	Slave 1	●	●	●	●	●	●	●	☀
	Slave 2	●	●	●	●	●	●	●	●

(Factory setting)

Pushbutton switches

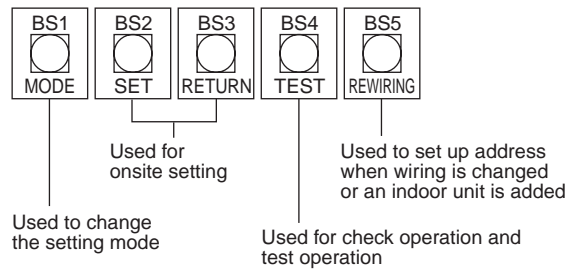

There are the following three setting modes.

① **Setting mode 1 (H1P off)**

Initial status (when normal) : Used to select the cool/heat setting. Also indicates during “abnormal”, “low noise control” and “demand control”.

② **Setting mode 2 (H1P on)**

Used to modify the operating status and to set program addresses, etc. Usually used in servicing the system.

③ **Monitor mode (H1P blinks)**

Used to check the program made in Setting mode 2.

■ **Mode changing procedure 1**

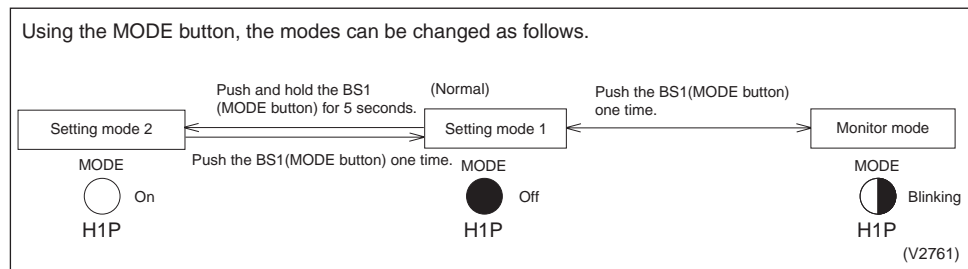

■ Mode changing procedure 2

(Set): Select mode with BS2 (SET button) in each selection step.

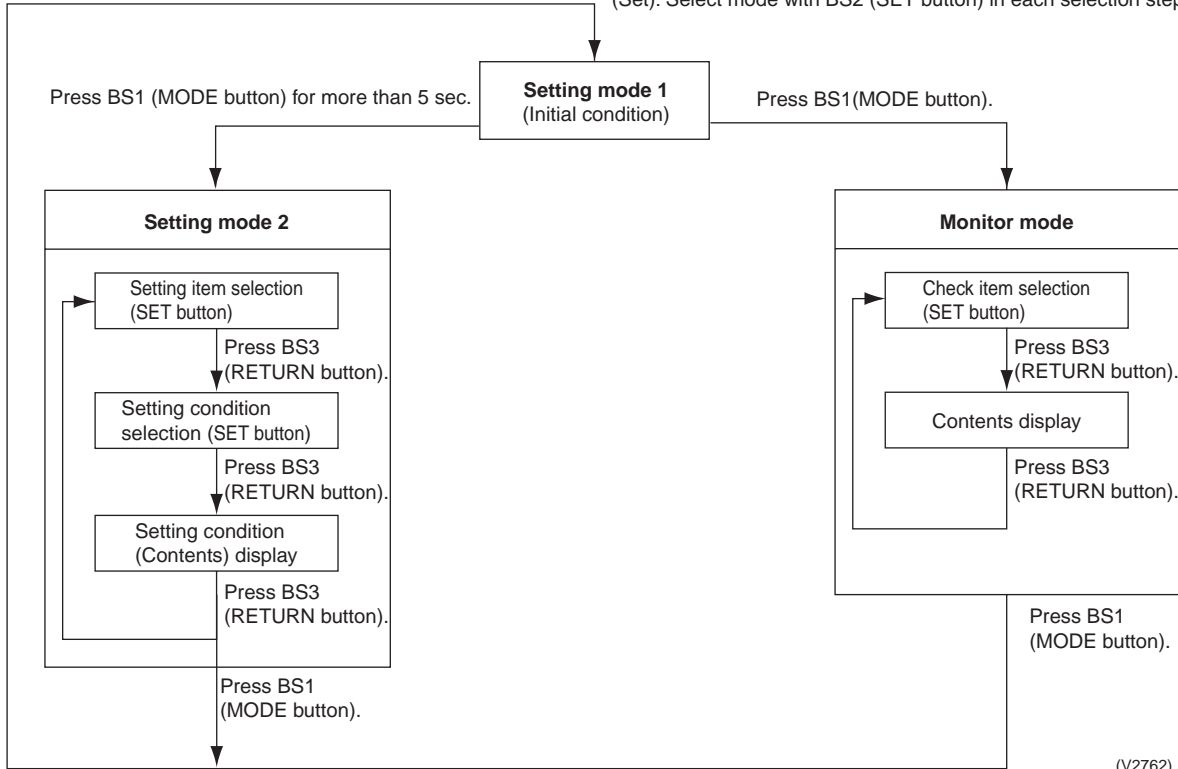

(V2762)

a. "Setting mode 1"

This mode is used to set and check the following items.

Check items The following items can be checked.

- (1) Current operating conditions (Normal / Abnormal / In check operation)
- (2) Low noise operating conditions (In normal operation / In low noise operation)
- (3) Demand operating conditions (In normal operation / In demand operation)

Procedure for checking check items

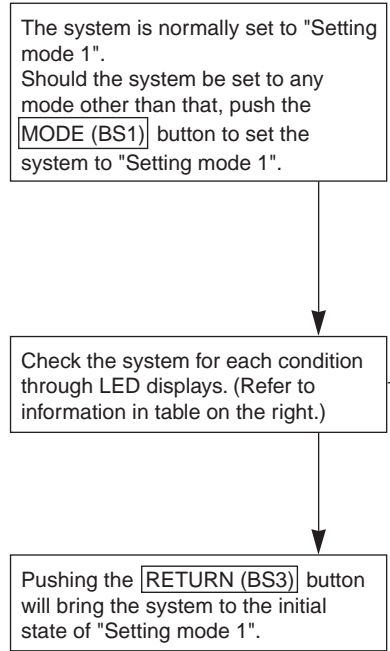

MODE H1P	TEST H2P	COOL/HEAT select			Low noise H6P	Demand H7P
		IND H3P	MASTER H4P	SLAVE H5P		
●	●	○	●	●	●	●

- Current operating conditions
 - Normal ○ Abnormal
 - In preparation or in check operation
- Low noise operating conditions
 - In normal operation
 - In low noise operation
- Demand operating conditions
 - In normal operation
 - In demand operation

(V2763)

b. "Setting mode 2"

Push and hold the **MODE (BS1)** button for 5 seconds and set to "Setting mode 2".

<Selection of setting items>

Push the **SET (BS2)** button and set the LED display to a setting item shown in the table on the right.
 ↓
 Push the **RETURN (BS3)** button and decide the item. (The present setting condition is blinked.)

<Selection of setting conditions>

Push the **SET (BS2)** button and set to the setting condition you want.
 ↓
 Push the **RETURN (BS3)** button and decide the condition.

Push the **RETURN (BS3)** button and set to the initial status of "Setting mode 2".

* If you become unsure of how to proceed, push the **MODE (BS1)** button and return to setting mode 1.

(V2764)

No.	Setting item	Description
0	Digital pressure gauge kit display	Used to make setting of contents to display on the digital pressure gauges (e.g. pressure sensors and temperature sensors)
1	Cool/heat unified address	Sets address for cool/heat unified operation.
2	Low noise/demand address	Address for low noise/demand operation
3	Test operation settings	Used to conduct test operation without making changes to the PC board and replacing the refrigerant, after the completion of maintenance.
5	Indoor unit forced fan H	Allows forced operation of indoor unit fan while unit is stopped. (H tap)
6	Indoor unit forced operation	Allows forced operation of indoor unit. (Forced thermostat ON)
8	Te setting	Target evaporation temperature for cooling
9	Tc setting	Target condensation temperature for heating
10	Defrost changeover setting	Changes the temperature condition for defrost and sets to quick defrost or slow defrost.
11	Sequential operation setting	Sets sequential operation (Factory set to ON)
12	External low noise setting / Demand setting	Reception of external low noise or demand signal
13	AIRNET address	Set address for AIRNET.
18	High static pressure setting	Make this setting in the case of operating in high static pressure mode with diffuser duct mounted. (In order to mount the diffuser duct, remove the cover from the outdoor unit fan.)
20	Additional refrigerant charge operation setting	Carries out additional refrigerant charge operation.
21	Refrigerant recovery/vacuuming mode setting	Sets to refrigerant recovery or vacuuming mode.
22	Night-time low noise setting	Sets automatic nighttime low noise operation in a simple way. The operating time is based on "Starting set" and "Ending set".
24	ENECUT test operation	Used to forcedly turn ON the ENECUT. (Be noted that the ENECUT is only functional with outdoor unit in the stopped state - Japanese domestic model only.)
25	Setting of external low noise level	Sets low noise level when the low noise signal is input from outside.
26	Night-time low noise operation start setting	Sets starting time of nighttime low noise operation. (Night-time low noise setting is also required.)
27	Night-time low noise operation end setting	Sets ending time of nighttime low noise operation. (Night-time low noise setting is also required.)
28	Power transistor check mode *Check after disconnection of compressor wires	Used for trouble diagnosis of DC compressor. Since the waveform of inverter is output without wiring to the compressor, it is convenient to probe whether the trouble comes from the compressor or PC board.
29	Capacity precedence setting	If the capacity control is required, the low noise control is automatically released by this setting during carrying out low noise operation and nighttime low noise operation.
30	Demand setting 1	Changes target value of power consumption when demand control 1 is input.
32	Normal demand setting	Normally enables demand control 1 without external input. (Effective to prevent a problem that circuit breaker of small capacity is shut down due to large load.)

No.	Setting item	Description
38	Emergency operation (Setting for the unit 1 operation prohibition in multi-outdoor-unit system)	Used to temporarily prohibit the applicable outdoor unit from operating should there be any faulty part in multi-outdoor-unit system. Since the comfortable environment is extremely impaired, prompt replacement of the part is required.
39	Emergency operation (Setting for the unit 2 operation prohibition in multi-outdoor-unit system)	
40	Emergency operation (Setting for the unit 3 operation prohibition in multi-outdoor-unit system)	
41	Prevention of minute heating operation by heating thermostat OFF unit or non-heating-operation unit	<p>Make this setting to shorten the BS Cool-Heat selection control time. However, make the setting, pay careful attention to the following:</p> <ul style="list-style-type: none"> • If the refrigerant piping between each BS unit connected to outdoor unit and indoor unit is not more than 10 m in length, this setting will be enabled. • If the refrigerant piping between BS unit and indoor unit is long in length, refrigerant passing sounds may become louder at the time of BS Cool-Heat selection. • This setting shortens the Cool-Heat selection time of all BS units provided in the same refrigerant system.
42	Setting of BS Cool-Heat selection control time	<p>Make this setting to prevent a rise in room temperature due to minute heating capacity generated by heating thermostat OFF unit or non-heating-operation unit while in heating operation.</p> <ul style="list-style-type: none"> • Used to prevent minute heating operation by setting the BS unit to COOL while in heating thermostat OFF or non-heating-operation mode. • With the BS unit set to default, enabling the minute heating prevention setting of outdoor unit will enable the minute heating prevention setting of all BS units connected to the outdoor unit. (BS unit default setting) • To make this setting by BS unit, make a change to the minute heating prevention setting of the BS unit. (In this case, enable the outdoor unit setting.)
51	Set-up of master and slave units for multi outdoor units	<p>Set up master and slave units for multi-connection outdoor units. After setting up, press the BS5 (REWIRING) button for 5 seconds or more.</p>

↑ The numbers in the "No." column represent the number of times to press the SET (BS2) button.

No.	Setting item display								Setting condition display			
	Setting item	MODE H1P	TEST H2P	C/H selection			Low noise H6P	Demand H7P			* Factory set	
				IND H3P	Master H4P	Slave H5P						
0	Digital pressure gauge kit display	☀	●	●	●	●	●	●	Address	0	☀ ● ● ● ● ● ● *	
									Binary number	1	☀ ● ● ● ● ● ☀	
									(4 digits)	~		
									15	☀ ● ● ☀ ☀ ☀ ☀		
1	Cool / Heat Unified address	☀	●	●	●	●	●	●	☀	Address	0	☀ ● ● ● ● ● ● *
										Binary number	1	☀ ● ● ● ● ● ☀
										(6 digits)	~	
									31	☀ ● ● ☀ ☀ ☀ ☀		
2	Low noise/demand address	☀	●	●	●	●	●	☀	●	Address	0	☀ ● ● ● ● ● ● *
										Binary number	1	☀ ● ● ● ● ● ☀
										(6 digits)	~	
									31	☀ ● ● ☀ ☀ ☀ ☀		
3	Test operation	☀	●	●	●	●	●	☀	☀	Test operation: OFF	☀ ● ● ● ● ● ☀ *	
										Test operation: ON	☀ ● ● ● ● ● ☀	
5	Indoor forced fan H	☀	●	●	●	☀	●	●	☀	Normal operation	☀ ● ● ● ● ● ☀ *	
										Indoor forced fan H	☀ ● ● ● ● ● ☀	
6	Indoor forced operation	☀	●	●	●	☀	☀	●	●	Normal operation	☀ ● ● ● ● ● ☀ *	
										Indoor forced operation	☀ ● ● ● ● ● ☀	
8	Te setting	☀	●	●	☀	●	●	●	●	Low (Level L)	☀ ● ● ● ● ● ☀	
										Normal (Level M)	☀ ● ● ● ● ● ☀ *	
										High ^①	☀ ● ● ● ● ● ☀	
										High ^②	☀ ● ● ● ● ● ☀	
										High ^③	☀ ● ● ● ● ● ☀	
										High ^④	☀ ● ● ● ● ● ☀	
High ^⑤	☀ ● ● ● ● ● ☀											
9	Tc setting	☀	●	●	☀	●	●	●	☀	Low	☀ ● ● ● ● ● ☀	
										Normal (factory setting)	☀ ● ● ● ● ● ☀ *	
										High	☀ ● ● ● ● ● ☀	
10	Defrost changeover setting	☀	●	●	☀	●	☀	●	●	Slow defrost	☀ ● ● ● ● ● ☀	
										Normal (factory setting)	☀ ● ● ● ● ● ☀ *	
										Quick defrost	☀ ● ● ● ● ● ☀	
11	Sequential operation setting	☀	●	●	☀	●	☀	☀	OFF	☀ ● ● ● ● ● ☀		
									ON	☀ ● ● ● ● ● ☀ *		
12	External low noise/demand setting	☀	●	●	☀	☀	●	●	●	External low noise/demand: NO	☀ ● ● ● ● ● ☀ *	
										External low noise/demand: YES	☀ ● ● ● ● ● ☀	
13	Aimet address	☀	●	●	☀	☀	●	●	☀	Address	0	☀ ● ● ● ● ● ● *
										Binary number	1	☀ ● ● ● ● ● ☀
										(6 digits)	~	
									63	☀ ☀ ☀ ☀ ☀ ☀		
18	High static pressure setting	☀	●	☀	●	●	☀	●	●	High static pressure setting: OFF	☀ ● ● ● ● ● ☀ *	
										High static pressure setting: ON	☀ ● ● ● ● ● ☀	
20	Additional refrigerant charging operation setting	☀	●	☀	●	☀	●	●	●	Refrigerant charging: OFF	☀ ● ● ● ● ● ☀ *	
										Refrigerant charging: ON	☀ ● ● ● ● ● ☀	
21	Refrigerant recovery/vacuuming mode setting	☀	●	☀	●	☀	●	☀	●	Refrigerant recovery / vacuuming: OFF	☀ ● ● ● ● ● ☀ *	
										Refrigerant recovery / vacuuming: ON	☀ ● ● ● ● ● ☀	
22	Night-time low noise setting	☀	●	☀	●	☀	☀	☀	●	OFF	☀ ● ● ● ● ● ● *	
										Level 1 (outdoor fan with 6 step or lower)	☀ ● ● ● ● ● ☀	
										Level 2 (outdoor fan with 5 step or lower)	☀ ● ● ● ● ● ☀	
										Level 3 (outdoor fan with 4 step or lower)	☀ ● ● ● ● ● ☀	

No.	Setting item display								Setting condition display * Factory set
	Setting item	MODE H1P	TEST H2P	C/H selection			Low noise H6P	Demand H7P	
				IND H3P	Master H4P	Slave H5P			
24	ENECUT test operation (Domestic Japan only)	☀	●	☀	☀	●	●	●	ENECUT output OFF ☀ ● ● ● ● ● ● ● ● * ENECUT output forced ON ☀ ● ● ● ● ● ● ● ●
25	Low noise setting	☀	●	☀	☀	●	●	☀	Level 1 (outdoor fan with 6 step or lower) ☀ ● ● ● ● ● ● ● ● Level 2 (outdoor fan with 5 step or lower) ☀ ● ● ● ● ● ● ● ● * Level 3 (outdoor fan with 4 step or lower) ☀ ● ● ● ● ● ● ● ●
26	Night-time low noise operation start setting	☀	●	☀	☀	●	☀	●	About 20:00 ☀ ● ● ● ● ● ● ● ● About 22:00 (factory setting) ☀ ● ● ● ● ● ● ● ● * About 24:00 ☀ ● ● ● ● ● ● ● ●
27	Night-time low noise operation end setting	☀	●	☀	☀	●	☀	☀	About 6:00 ☀ ● ● ● ● ● ● ● ● About 7:00 ☀ ● ● ● ● ● ● ● ● About 8:00 (factory setting) ☀ ● ● ● ● ● ● ● ● *
28	Power transistor check mode	☀	●	☀	☀	☀	●	●	OFF ☀ ● ● ● ● ● ● ● ● * ON ☀ ● ● ● ● ● ● ● ●
29	Capacity precedence setting	☀	●	☀	☀	☀	●	☀	OFF ☀ ● ● ● ● ● ● ● ● * ON ☀ ● ● ● ● ● ● ● ●
30	Demand setting 1	☀	●	☀	☀	☀	☀	●	60 % demand ☀ ● ● ● ● ● ● ● ● 70 % demand ☀ ● ● ● ● ● ● ● ● * 80 % demand ☀ ● ● ● ● ● ● ● ●
32	Normal demand setting	☀	☀	●	●	●	●	●	OFF ☀ ● ● ● ● ● ● ● ● * Demand 1 ☀ ● ● ● ● ● ● ● ● Demand 2 ☀ ● ● ● ● ● ● ● ●
38	Emergency operation (Master unit is inhibited to operate.)	☀	☀	●	●	☀	☀	●	OFF ☀ ● ● ● ● ● ● ● ● * Master unit operation: Inhibited ☀ ● ● ● ● ● ● ● ●
39	Emergency operation (Slave unit 1 is inhibited to operate.)	☀	☀	●	●	☀	☀	☀	OFF ☀ ● ● ● ● ● ● ● ● * Slave unit 1 operation: Inhibited ☀ ● ● ● ● ● ● ● ●
40	Emergency operation (Slave unit 2 is inhibited to operate.)	☀	☀	●	☀	●	●	●	OFF ☀ ● ● ● ● ● ● ● ● * Slave unit 2 operation: Inhibited ☀ ● ● ● ● ● ● ● ●
41	Prevention of minute heating operation by heating thermostat OFF unit or non-heating-operation unit	☀	☀	●	☀	●	●	☀	OFF ☀ ● ● ● ● ● ● ● ● Non-heating-operation unit ☀ ● ● ● ● ● ● ● ● Heating thermostat OFF unit ☀ ● ● ● ● ● ● ● ● Non-heating-operation + Thermostat OFF unit ☀ ● ● ● ● ● ● ● ● *
42	Setting of BS Cool-Heat selection control time	☀	☀	●	☀	●	☀	●	6 min. ☀ ● ● ● ● ● ● ● ● * 4 min. ☀ ● ● ● ● ● ● ● ●
51	Master-slave set-up for multi outdoor units	☀	☀	☀	●	●	☀	☀	Automatic judgment ☀ ● ● ● ● ● ● ● ● * Master ☀ ● ● ● ● ● ● ● ● Slave 1 ☀ ● ● ● ● ● ● ● ● Slave 2 ☀ ● ● ● ● ● ● ● ●

↑ The numbers in the "No." column represent the number of times to press the SET (BS2) button.

c. Monitor mode

To enter the monitor mode, push the **MODE (BS1)** button when in "Setting mode 1".

<Selection of setting item>

Push the **SET (BS2)** button and set the LED display to a setting item.

<Confirmation on setting contents>

Push the **RETURN (BS3)** button to display different data of set items.

Push the **RETURN (BS3)** button and switches to the initial status of "Monitor mode".

* Push the **MODE (BS1)** button and returns to "Setting mode 1".

(V2765)

No.	Setting item	LED display							Data display
		H1P	H2P	H3P	H4P	H5P	H6P	H7P	
0	Various settings	☀	●	●	●	●	●	●	Lower 4 digits
1	C/H unified address	☀	●	●	●	●	●	☀	Lower 6 digits
2	Low noise/demand address	☀	●	●	●	●	☀	●	
3	Not used	☀	●	●	●	●	☀	☀	
4	Airnet address	☀	●	●	●	☀	●	●	
5	Number of connected indoor units *1	☀	●	●	●	☀	●	☀	
6	Number of connected BS units *2	☀	●	●	●	☀	☀	●	
7	Number of connected zone units (Fixed to "0")	☀	●	●	●	☀	☀	☀	Lower 4 digits: upper
8	Number of outdoor units *3	☀	●	●	☀	●	●	●	
9	Number of BS units *4	☀	●	●	☀	●	●	☀	
10	Number of BS units *4	☀	●	●	☀	●	☀	●	
11	Number of zone units	☀	●	●	☀	●	☀	☀	
12	Number of terminal units *5	☀	●	●	☀	☀	●	●	
13	Number of terminal units *5	☀	●	●	☀	☀	●	☀	Lower 4 digits: lower
14	Contents of malfunction (the latest)	☀	●	●	☀	☀	☀	●	Malfunction code table
15	Contents of malfunction (1 cycle before)	☀	●	●	☀	☀	☀	☀	
16	Contents of malfunction (2 cycle before)	☀	●	☀	●	●	●	●	
20	Contents of retry (the latest)	☀	●	☀	●	☀	●	●	
21	Contents of retry (1 cycle before)	☀	●	☀	●	☀	●	☀	
22	Contents of retry (2 cycle before)	☀	●	☀	●	☀	☀	●	Refer page 262.
25	Number of multi connection outdoor units	☀	●	☀	☀	●	●	☀	

The numbers in the "No." column represent the number of times to press the SET (BS2) button.

- *1: Number of connected indoor units
Used to make setting of the number of indoor units connected to an outdoor unit.
- *2: Number of connected BS units
Used to make setting of the number of BS units connected to an outdoor unit.
- *3: Number of outdoor units
Used to make setting of the number of outdoor units connected to DIII-NET that is one of the communication lines.
- *4: Number of BS units
Used to make setting of the number of BS units connected to DIII-NET that is one of the communication lines.
- *5: Number of terminal units
Used to make setting of the number of indoor units connected to DIII-NET that is one of the communication lines.
(Only available for VRV indoor units)

Setting item 0 Display contents of “Number of units for various settings”

EMG operation / backup operation setting	ON	☼	●	●	☼	●	●	●
	OFF	☼	●	●	●	●	●	●
Defrost select setting	Short	☼	●	●	●	☼	●	●
	Medium	☼	●	●	●	☼	●	●
	Long	☼	●	●	●	●	●	●
Te setting	L	☼	●	●	●	●	●	●
	M	☼	●	●	●	●	☼	●
	H ①~⑤	☼	●	●	●	●	☼	●
Tc setting	L	☼	●	●	●	●	●	●
	M	☼	●	●	●	●	●	☼
	H	☼	●	●	●	●	●	☼

★ Data such as addresses and number of units is expressed as binary numbers; the two ways of expressing are as follows:

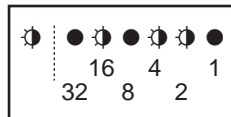

The No. 1 cool/heat unified address is expressed as a binary number consisting of the lower 6 digits. (0 - 63)

In ① the address is 010110 (binary number), which translates to $16 + 4 + 2 = 22$ (base 10 number). In other words, the address is 22.

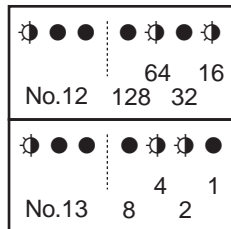

The number of terminal blocks for No. 12 and 13 is expressed as an 8-digit binary number, which is the combination of four upper, and four lower digits for No. 12 and 13 respectively. (0 - 128)
 In ② the address for No. 12 is 0101, the address for No. 13 is 0110, and the combination of the two is 01010110 (binary number), which translates to $64 + 16 + 4 + 2 = 86$ (base 10 number). In other words, the number of terminal block is 86.

★ See the preceding page for a list of data, etc. for No. 0 - 25.

3.2.4 Cool / Heat Mode Switching

Set Cool/Heat Separately for Each BS Unit by Cool/Heat Selector.

Set remote control change over switch (SS1, SS2) as following:

- When using COOL/HEAT selector, turn this switch to the BS side.



NOTE: This setting must be completed before turning power supply ON.

When using cool/heat selector, connect to the terminal A, B and C on the EC of the electric parts box.

EXAMPLE OF TRANSMISSION LINE CONNECTION

- Example of connecting transmission wiring.
Connect the transmission wirings as shown in the Fig. 1.

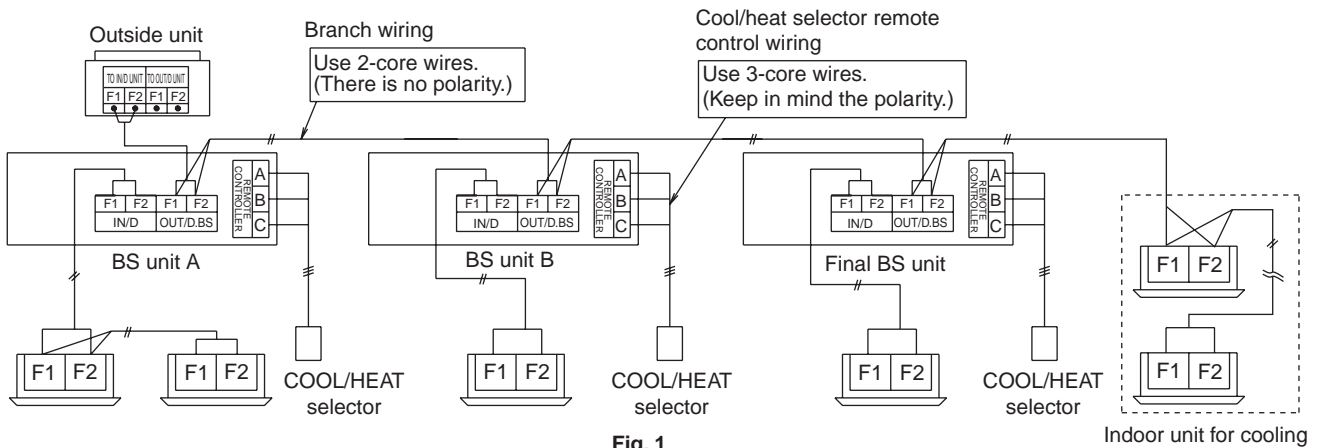
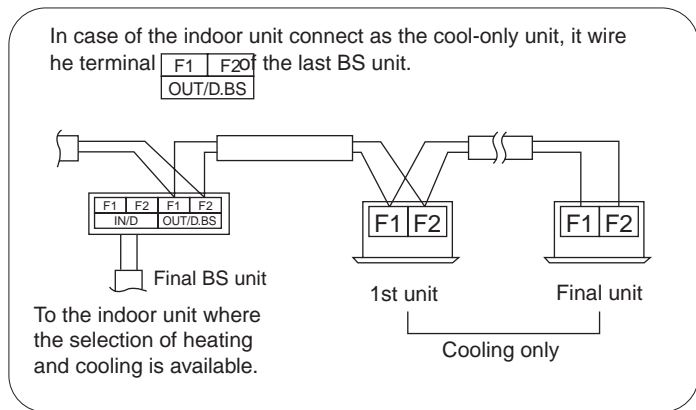

Fig. 1

3.2.5 Setting of Low Noise Operation and Demand Operation

Setting of Low Noise Operation

By connecting the external contact input to the low noise input of the outdoor unit external control adaptor (optional), you can lower operating noise.

Setting	Content
Level 1	Set the outdoor unit fan to Step 5 or lower.
Level 2	Set the outdoor unit fan to Step 4 or lower.
Level 3	Set the outdoor unit fan to Step 3 or lower.

A. When the low noise operation is carried out by external instructions (with the use of the external control adaptor for outdoor unit)

1. Connect the external adaptor for the outdoor unit, and then connect the external input wiring to the low-noise operation input terminal on the terminal block (X1M). (Refer to the figure shown below.)
2. While in "Setting mode 2", set the setting condition for set item No. 12 (Setting of external low noise/demand operation) to "YES".
3. If necessary, while in "Setting mode 2", select the setting condition (i.e., "Level 1", "Level 2", or "Level 3") for set item No. 25 (Setting of external low noise level).
4. If necessary, while in "Setting mode 2", set the setting condition for the set item No. 29 (Setting of capacity precedence) to "ON".
(If the condition is set to "ON", when the air-conditioning load reaches a high level, the low noise operation command will be ignored to put the system into normal operation mode.)

B. When the low noise operation is carried out automatically at night (The external control adaptor for outdoor unit is not required)

1. While in "Setting mode 2", select the setting condition (i.e., "Level 1", "Level 2", or "Level 3") for set item No. 22 (Setting of nighttime low noise level).
2. If necessary, while in "Setting mode 2", select the setting condition (i.e., "20:00", "22:00", or "24:00") for set item No. 26 (Setting of start time of nighttime low noise operation).
(Use the start time as a guide since it is estimated according to outdoor temperatures.)
3. If necessary, while in "Setting mode 2", select the setting condition (i.e., "06:00", "07:00", or "08:00") for set item No. 27 (Setting of end time of nighttime low noise operation).
(Use the end time as a guide since it is estimated according to outdoor temperatures.)
4. If necessary, while in "Setting mode 2", set the setting condition for set item No. 29 (Setting of capacity precedence) to "ON".
(If the condition is set to "ON", when the air-conditioning load reaches a high level, the system will be put into normal operation mode even during nighttime.)

If carrying out demand or low-noise input, connect the terminals of the external control adaptor for outdoor unit as shown below.

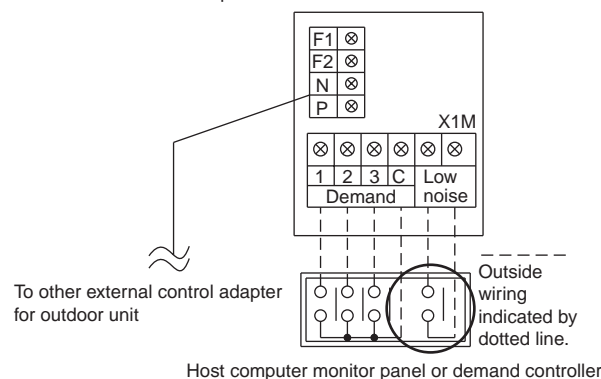

Image of operation in the case of A

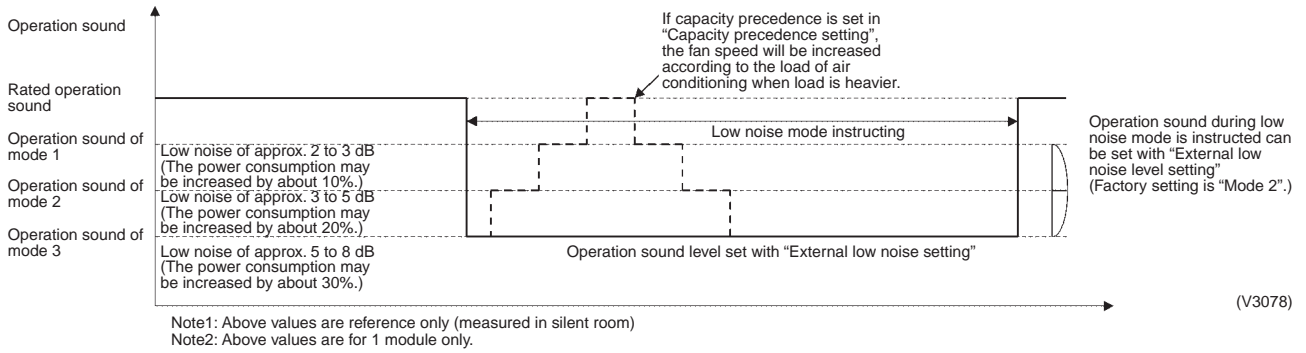

Image of operation in the case of B

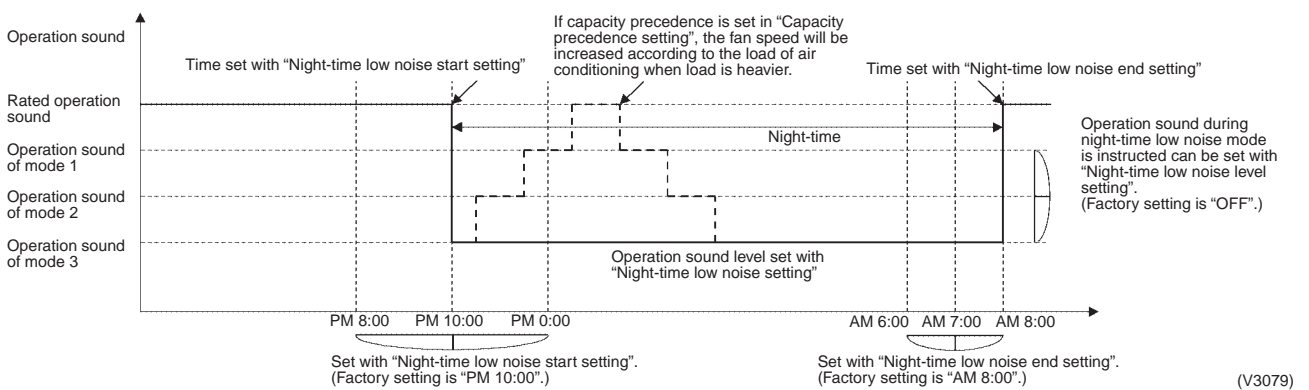
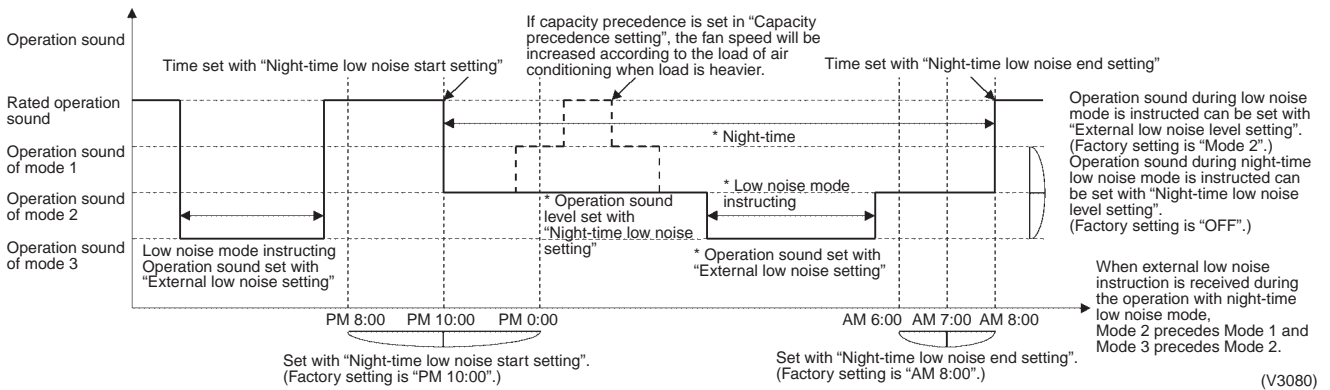

Image of operation in the case of A and B



Setting of Demand Operation

By connecting the external contact input to the demand input of the outdoor unit external control adaptor (optional), the power consumption of unit operation can be saved suppressing the compressor operating condition.

Description of setting			Setting procedure	
Setting item	Condition	Description	External control adaptor	Outdoor unit PC board
Demand 1	Level 1	Operate with power of approx. 60% or less of the rating.	Short-circuit between "1" and "C" of the terminal block (TeS1).	Set the setting item No. 32 to "Demand 1" and the setting item No. 30 to "Level 1".
	Level 2	Operate with power of approx. 70% or less of the rating.		Set the setting item No. 32 to "Demand 1" and the setting item No. 30 to "Level 2".
	Level 3	Operate with power of approx. 80% or less of the rating.		Set the setting item No. 32 to "Demand1" and the setting item No. 30 to "Level 3".
Demand 2	—	Operate with power of approx. 40% or less of the rating.	Short-circuit between "2" and "C".	Set the setting item No. 32 to "Demand 2".
Demand 3	—	Operate with forced thermostat OFF	Short-circuit between "3" and "C"	—

A. When the demand operation is carried out by external instructions (with the use of the external control adaptor for outdoor unit).

1. Connect the external adaptor of the outdoor unit, and then connect the external input wiring to the low-noise operation input terminal on the terminal block (X1M). (Refer to the figure shown below.)
2. While in "Setting mode 2", set the setting condition for set item No. 12 (Setting of external low noise/demand operation) to "YES".
3. If necessary, while in "Setting mode 2", select the set item No. 30 (Setting of Demand 1 level) and then set the setting condition to targeted mode.

B. When the Normal demand operation is carried out. (Use of the external control adaptor for outdoor unit is not required.)

1. While in "Setting mode 2", make setting of the set item No. 32 (Setting of constant demand) to "ON".
2. While in "Setting mode 2", select the set item No. 30 (Setting of Demand 1 level) and then set the setting condition to targeted mode.

If carrying out demand or low-noise input, connect the terminals of the external control adaptor for outdoor unit as shown below.

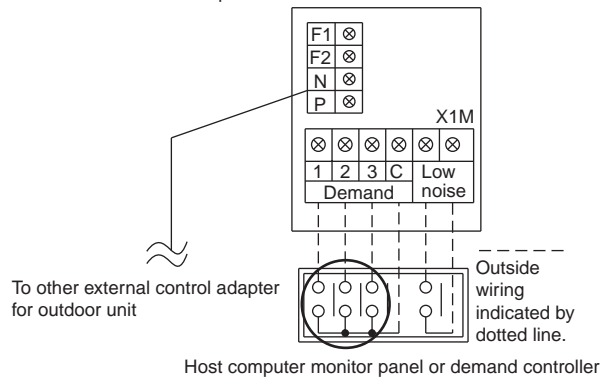

Image of operation in the case of A

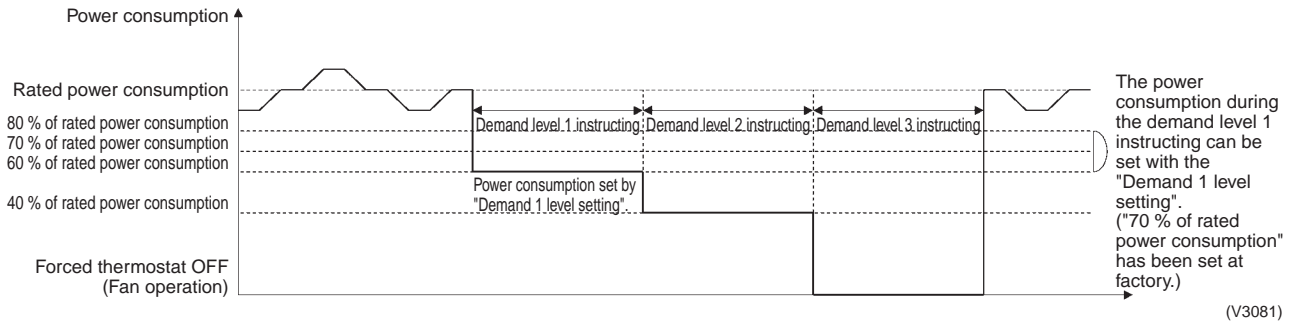

Image of operation in the case of B

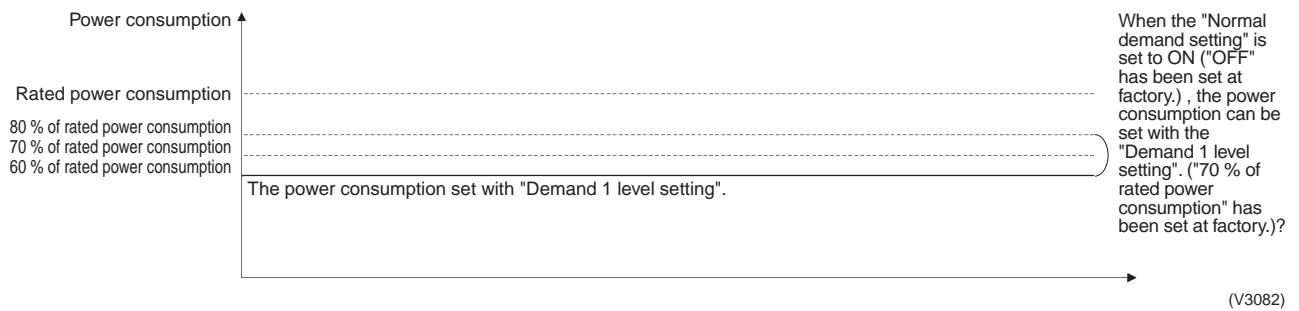
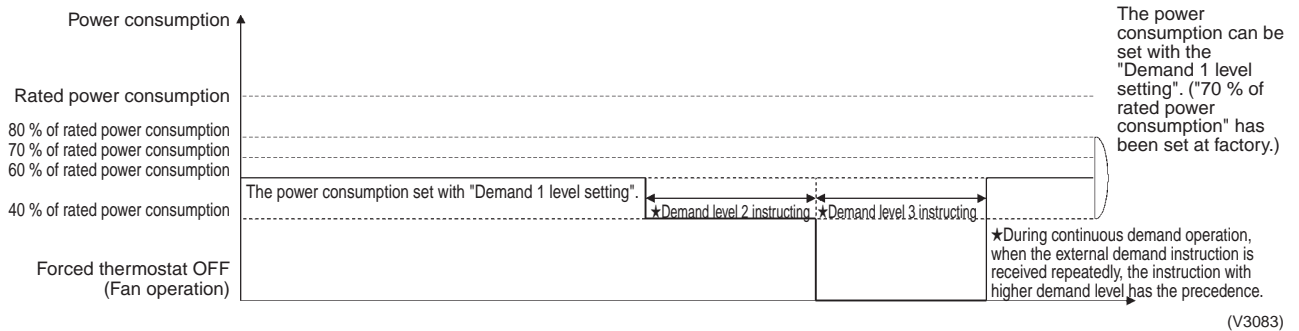

Image of operation in the case of A and B



Detailed Setting Procedure of Low Noise Operation and Demand Control

1. Setting mode 1 (H1P off)

- ① In setting mode 2, push the BS1 (MODE button) one time. → Setting mode 2 is entered and H1P lights.
During the setting mode 1 is displayed, "In low noise operation" and "In demand control" are displayed.

2. Setting mode 2 (H1P on)

- ① In setting 1, push and hold the BS1 (MODE button) for more than 5 seconds. → Setting mode 2 is entered and H1P lights.
- ② Push the BS2 (SET button) several times and match the LED display with the Setting No. you want.
- ③ Push the BS3 (RETURN button) one time, and the present setting content is displayed.
→ Push the BS2 (SET button) several times and match the LED display with the setting content (as shown below) you want.
- ④ Push the BS3 (RETURN button) two times. → Returns to ①.
- ⑤ Push the BS1 (MODE button) one time. → Returns to the setting mode 1 and turns H1P off.

O: ON ●: OFF ☼: Blink

Setting No.	Setting contents	① Setting No. indication							② Setting No. indication							Setting contents	③ Setting contents indication (Initial setting)							
		H1P	H2P	H3P	H4P	H5P	H6P	H7P	H1P	H2P	H3P	H4P	H5P	H6P	H7P		H1P	H2P	H3P	H4P	H5P	H6P	H7P	
		12	External low noise / Demand setting	☼	●	●	●	●	●	●	☼	●	●	☼	☼		●	●	NO (Factory setting)	☼	●	●	●	●
22	Night-time low noise setting								☼	●	☼	●	☼	☼	●	YES	☼	●	●	●	●	●	☼	●
															OFF (Factory setting)	☼	●	●	●	●	●	●	●	
															Mode 1	☼	●	●	●	●	●	●	☼	
															Mode 2	☼	●	●	●	●	●	☼	●	
														Mode 3	☼	●	●	●	●	●	☼	☼		
25	External low noise setting							☼	●	☼	☼	●	●	☼	Mode 1	☼	●	●	●	●	●	●	☼	
															Mode 2 (Factory setting)	☼	●	●	●	●	●	☼	●	
															Mode 3	☼	●	●	●	☼	●	●		
26	Night-time low noise start setting							☼	●	☼	☼	●	☼	●	PM 8:00	☼	●	●	●	●	●	●	☼	
															PM 10:00 (Factory setting)	☼	●	●	●	●	●	☼	●	
															PM 0:00	☼	●	●	●	☼	●	●		
27	Night-time low noise end setting							☼	●	☼	☼	●	☼	☼	AM 6:00	☼	●	●	●	●	●	●	☼	
															AM 7:00	☼	●	●	●	●	●	☼	●	
															AM 8:00 (Factory setting)	☼	●	●	●	☼	●	●		
29	Capacity precedence setting							☼	●	☼	☼	☼	●	☼	Low noise precedence (Factory setting)	☼	●	●	●	●	●	●	☼	
															Capacity precedence	☼	●	●	●	●	●	☼	●	
30	Demand setting 1							☼	●	☼	☼	☼	☼	●	60 % of rated power consumption	☼	●	●	●	●	●	●	☼	
															70 % of rated power consumption (Factory setting)	☼	●	●	●	●	●	☼	●	
															80 % of rated power consumption	☼	●	●	●	☼	●	●		
32	Normal demand setting							☼	●	●	●	●	●	●	OFF (Factory setting)	☼	●	●	●	●	●	●	☼	
															ON	☼	●	●	●	●	●	☼	●	

Setting mode indication section

Setting No. indication section

Set contents indication section

3.2.6 Setting of Refrigerant Recovery Mode

When carrying out the refrigerant collection on site, fully open the respective expansion valve of indoor and outdoor units.

All indoor and outdoor unit's operation are prohibited.

[Operation procedure]

① In **setting mode 2** with units in stop mode, set "Refrigerant Recovery / Vacuuming mode" to ON. The respective expansion valve of indoor and outdoor units are fully opened. (H2P turns to display "TEST OPERATION" (blinks), "TEST OPERATION" and "UNDER CENTRALIZED CONTROL" are displayed on the remote control, and the all indoor / outdoor unit operation is prohibited.

After setting, do not cancel "Setting Mode 2" until completion of refrigerant recovery operation.

② Collect the refrigerant using a refrigerant recovery unit. (See the instruction attached to the refrigerant recovery unit for more detail.)

③ Press Mode button "BS1" once and reset "Setting Mode 2".

3.2.7 Setting of Vacuuming Mode

In order to perform vacuuming operation at site, fully open the expansion valves of indoor and outdoor units and turn on some solenoid valves.

[Operating procedure]

- ① With **Setting Mode 2** while the unit stops, set "Refrigerant recovery / Vacuuming mode" to ON. The expansion valves of indoor and outdoor units fully open and some of solenoid valves open.
(H2P blinks to indicate the test operation, and the remote control displays "Test Operation" and "Under centralized control", thus prohibiting operation.)
After setting, do not cancel "Setting Mode 2" until completion of Vacuuming operation.
- ② Use the vacuum pump to perform vacuuming operation.
- ③ Press Mode button "BS1" once and reset "Setting Mode 2".

3.2.8 Check Operation Detail

CHECK OPERATION FUNCTION

(Press the MODE button BS1 once and set to SETTING MODE 1 (H1P: OFF))

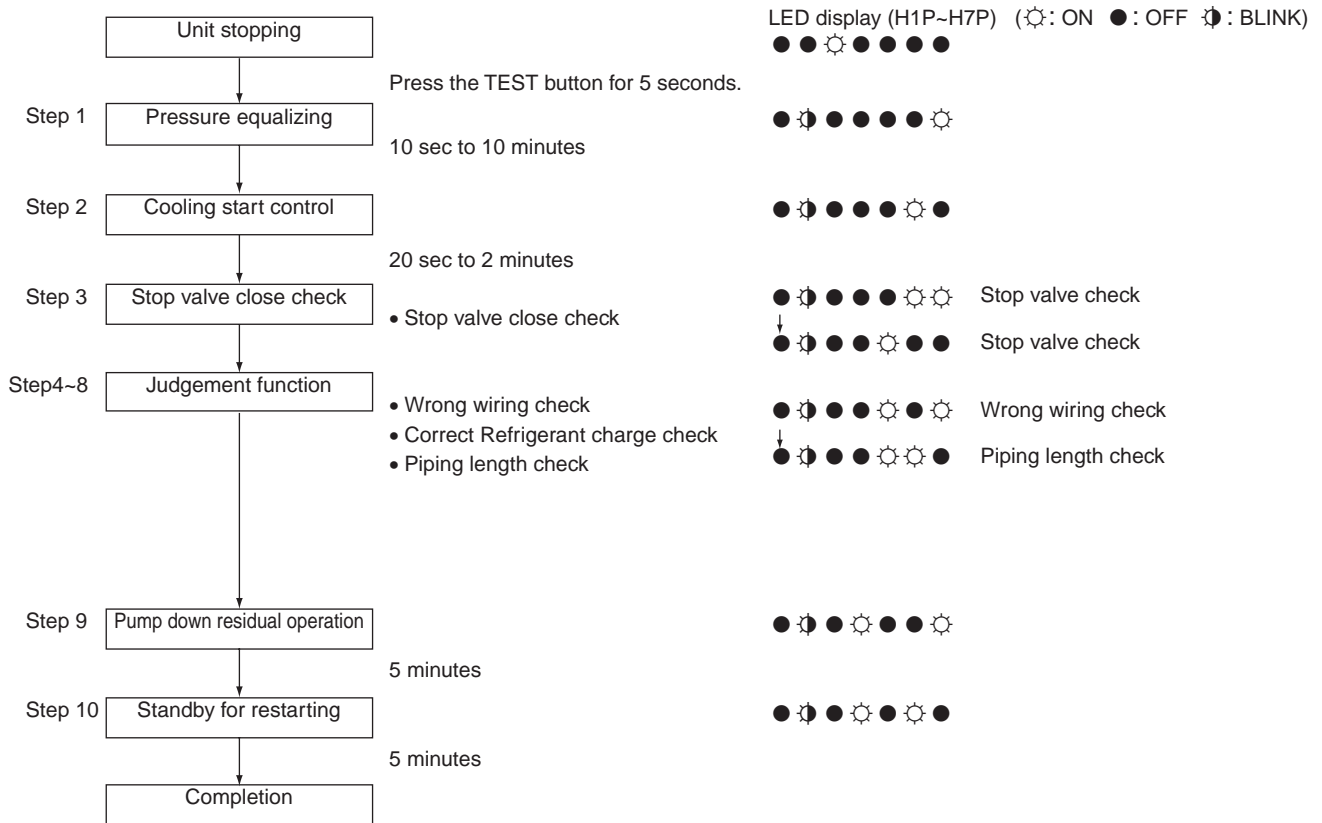

3.2.9 Emergency Operation

If any of the compressors goes wrong, disable the relevant compressor or the relevant outdoor unit from operating, and then conduct emergency operation only with operational compressors or outdoor units.

There are two ways of conducting the Emergency operation : ① with remote control reset and ② by setting outdoor unit PC board.

Operating method	① Emergency operation with remote control reset (Auto backup operation)	② Emergency operation with outdoor unit PC board setting (Manual backup operation)
Applicable model		
REYQ8 to 16PY1	–	Backup operation by the compressor
REYQ18 to 48PY1	Backup operation by the indoor unit	Backup operation by the outdoor unit

① Emergency operation with remote control reset

On the multi outdoor unit system, if any of the outdoor unit line causes a malfunction (in this case, the system will stop and the relevant malfunction code will be displayed on the indoor remote control), disable only the relevant outdoor unit from operating for a 8 hours using the indoor remote control, and then conduct emergency operation with operational outdoor units.

[Emergency operation method]

- Reset the remote control (i.e., press the **RUN/STOP** button on the remote control for 4 seconds or more) when the outdoor unit stops because of malfunction state.

[Details of operation]

- Automatically disable the defective outdoor unit from operating, and then operate other outdoor units.
- The following section shows malfunction codes on which this emergency operation is possible.

E3, E4, E5, E7 (*1)
 F3
 H7 (*1), H9
 J2, J3, J5, J6, J7, J9, JA, JC
 L1, L4, L5, L8, L9, LC
 U2, UJ

*1: When malfunction codes E7 and H7 are shown, the possibility of emergency operation is decided as follows.

While in heating or cooling-heating concurrent operation

- One out of three connected outdoor units malfunctions. → Emergency operation is possible.
- Two out of three connected outdoor units malfunction. → Emergency operation is not possible.
- One out of two connected outdoor units malfunctions. → Emergency operation is not possible.

② Emergency operation by setting outdoor unit PC board

In malfunction stop state of the outdoor unit due to defective compressor, by setting the relevant compressor or relevant outdoor unit to "Disabling operation setting", the emergency operation is conducted with operational compressors or outdoor units.

<REYQ8 to 16PY1>

○ Disabling the compressor 1 (on the right side) from operating:

Set No. 38 of setting mode 2 to "Disable-compressor-1 operation".

LED display (☉: ON, ●: OFF, ⚡: Blink)

(Step)

- H1P-----H7P
- (1) Press and hold the PAGE button (BS1) for 5 sec. or more. ☉ ● ● ● ● ● ● ●
 - (2) Press the OPERATE button (BS2) 38 times. ☉ ☉ ● ● ☉ ☉ ●
 - (3) Press the CHECK button (BS3) once. ☉ ● ● ● ● ● ● ⚡ (Factory setting)
 - (4) Press the OPERATE button (BS2) once. ☉ ● ● ● ● ● ● ⚡
 - (5) Press the CHECK button (BS3) twice. ☉ ● ● ● ● ● ● ●

- (6) Press the PAGE button (BS1) once. ●●●●●●●●
- Disabling the compressor 2 (on the left side) from operating:
Set No. 39 of setting mode 2 to "Disable-compressor-2 operation".

	LED display (☼: ON, ●: OFF, ⚡: Blink)
	H1P-----H7P
(Step)	
(1) Press the PAGE button (BS1) for 5 seconds or more.	☼●●●●●●●●
(2) Press the OPERATE button (BS2) 39 times.	☼☼●●●●☼☼
(3) Press the CHECK button (BS3) once.	☼●●●●●●●●⚡ (Factory setting)
(4) Press the OPERATE button (BS2) once.	☼●●●●●●●●⚡
(5) Press the CHECK button (BS3) twice.	☼●●●●●●●●
(6) Press the PAGE button (BS1) once.	●●●●☼●●●●

<REYQ18 to 48PY1>

Make disable-operation setting by each outdoor unit.
Make the following setting on the outdoor unit 1. (If this setting is made on an outdoor unit other than the outdoor unit 2, the setting will become invalid.)

* It is possible to tell the outdoor units 1, 2, and 3 according to the LED displays shown below.

	LED display (☼: ON, ●: OFF, ⚡: Blink)
	H1P-----H7P H8P
Outdoor unit 1:	●●●●☼●●●●☼
Outdoor unit 2:	●●●●●●●●●●⚡
Outdoor unit 3:	●●●●●●●●●●● (Factory setting)

- Disabling the outdoor unit 1 to operate:
Set No. 38 of setting mode 2 to "Disable outdoor unit 1 operation".

	LED display (☼: ON, ●: OFF, ⚡: Blink)
	H1P-----H7P
(Step)	
(1) Press and hold the PAGE button (BS1) for 5 sec. or more.	☼●●●●●●●●
(2) Press the OPERATE button (BS2) 38 times.	☼☼●●●●☼☼●
(3) Press the CHECK button (BS3) once.	☼●●●●●●●●⚡ (Factory setting)
(4) Press the OPERATE button (BS2) once.	☼●●●●●●●●⚡
(5) Press the CHECK button (BS3) twice.	☼●●●●●●●●
(6) Press the PAGE button (BS1) once.	●●●●☼●●●●

- Disabling the outdoor unit 2 from operating:
Set No. 39 of setting mode 2 to "Disable-outdoor-unit-2 operation".

	LED display (☼: ON, ●: OFF, ⚡: Blink)
	H1P-----H7P
(Step)	
(1) Press the PAGE button (BS1) for 5 seconds or more.	☼●●●●●●●●
(2) Press the OPERATE button (BS2) 39 times.	☼☼●●●●☼☼
(3) Press the CHECK button (BS3) once.	☼●●●●●●●●⚡ (Factory setting)
(4) Press the OPERATE button (BS2) once.	☼●●●●●●●●⚡
(5) Press the CHECK button (BS3) twice.	☼●●●●●●●●
(6) Press the PAGE button (BS1) once.	●●●●☼●●●●

- Disabling the outdoor unit 3 from operating:
Set No. 40 of setting mode 2 to "Disable-outdoor-unit-1 operation".

	LED display (☼: ON, ●: OFF, ⚡: Blink)
	H1P-----H7P
(Step)	
(1) Press the PAGE button (BS1) for 5 seconds or more.	☼●●●●●●●●
(2) Press the OPERATE button (BS2) 40 times.	☼☼●●☼●●●●
(3) Press the CHECK button (BS3) once.	☼●●●●●●●●⚡ (Factory setting)
(4) Press the OPERATE button (BS2) once.	☼●●●●●●●●⚡

- (5) Press the CHECK button (BS3) twice. ☀ ● ● ● ● ● ●
- (6) Press the PAGE button (BS1) once. ● ● ☀ ● ● ● ● ●

[Cancel of Emergency Operation]

To cancel the emergency operation, conduct the following setting. (Return to Factory setting.)

<REYQ8 to 16PY1>

○ Cancel disabling the compressor 1 (on the right side) from operating:

Set No. 38 "Disable-compressor-1 operation" of setting mode 2 to "OFF".

- LED display (☀: ON, ●: OFF, ⚡: Blink)
- H1P-----H7P
- (Step)
 - (1) Press and hold the PAGE button (BS1) for 5 sec. or more. ☀ ● ● ● ● ● ●
 - (2) Press the OPERATE button (BS2) 38 times. ☀ ☀ ● ● ☀ ☀ ● ●
 - (3) Press the CHECK button (BS3) once. ☀ ● ● ● ● ● ⚡
 - (4) Press the OPERATE button (BS2) once. ☀ ● ● ● ● ● ⚡ (Factory setting)
 - (5) Press the CHECK button (BS3) twice. ☀ ● ● ● ● ● ●
 - (6) Press the PAGE button (BS1) once. ● ● ☀ ● ● ● ● ●

○ Cancel disabling the compressor 2 (on the left side) from operating:

Set No. 39 "Disable-compressor-2 operation" of setting mode 2 to "OFF".

- LED display (☀: ON, ●: OFF, ⚡: Blink)
- H1P-----H7P
- (Step)
 - (1) Press the PAGE button (BS1) for 5 seconds or more. ☀ ● ● ● ● ● ●
 - (2) Press the OPERATE button (BS2) 39 times. ☀ ☀ ● ● ☀ ☀ ● ●
 - (3) Press the CHECK button (BS3) once. ☀ ● ● ● ● ● ⚡
 - (4) Press the OPERATE button (BS2) once. ☀ ● ● ● ● ● ⚡ (Factory setting)
 - (5) Press the CHECK button (BS3) twice. ☀ ● ● ● ● ● ●
 - (6) Press the PAGE button (BS1) once. ● ● ☀ ● ● ● ● ●

<REYQ18 to 48PY1>

Cancel the disable-operation setting by each outdoor unit.

Make the following setting on the outdoor unit 1. (If this setting is made on an outdoor unit other than the outdoor unit 2, the setting will become invalid.)

*It is possible to tell the outdoor units 1, 2, and 3 according to the LED displays shown below.

- LED display (☀: ON, ●: OFF, ⚡: Blink)
- H1P-----H7P H8P
- Outdoor unit 1: ● ● ☀ ● ● ● ● ● ☀
 - Outdoor unit 2: ● ● ● ● ● ● ● ⚡
 - Outdoor unit 3: ● ● ● ● ● ● ● ● (Factory setting)

○ Cancel disabling the outdoor unit 1 from operating:

Set No. 38 "Disable outdoor unit 1 operation" of setting mode 2 to "OFF".

- LED display (☀: ON, ●: OFF, ⚡: Blink)
- H1P-----H7P
- (Step)
 - (1) Press and hold the PAGE button (BS1) for 5 sec. or more. ☀ ● ● ● ● ● ●
 - (2) Press the OPERATE button (BS2) 38 times. ☀ ☀ ● ● ☀ ☀ ● ●
 - (3) Press the CHECK button (BS3) once. ☀ ● ● ● ● ● ⚡
 - (4) Press the OPERATE button (BS2) once. ☀ ● ● ● ● ● ⚡ (Factory setting)
 - (5) Press the CHECK button (BS3) twice. ☀ ● ● ● ● ● ●
 - (6) Press the PAGE button (BS1) once. ● ● ☀ ● ● ● ● ●

○ Cancel disabling the outdoor unit 2 from operating:

Set No. 39 "Disable-outdoor-unit-2 operation" of setting mode 2 to "OFF".

(Step)	LED display (☀: ON, ●: OFF, ⚡: Blink)
	H1P-----H7P
(1) Press the PAGE button (BS1) for 5 seconds or more.	☀ ● ● ● ● ● ●
(2) Press the OPERATE button (BS2) 39 times.	☀ ☀ ● ● ☀ ☀ ☀
(3) Press the CHECK button (BS3) once.	☀ ● ● ● ● ● ⚡ ●
(4) Press the OPERATE button (BS2) once.	☀ ● ● ● ● ● ● ⚡ (Factory setting)
(5) Press the CHECK button (BS3) twice.	☀ ● ● ● ● ● ● ●
(6) Press the PAGE button (BS1) once.	● ● ☀ ● ● ● ● ●

○ Cancel disabling the outdoor unit 3 from operating:

Set No. 40 "Disable-outdoor-unit-3 operation" of setting mode 2 to "OFF".

(Step)	LED display (☀: ON, ●: OFF, ⚡: Blink)
	H1P-----H7P
(1) Press the PAGE button (BS1) for 5 seconds or more.	☀ ● ● ● ● ● ●
(2) Press the OPERATE button (BS2) 40 times.	☀ ☀ ● ● ☀ ● ● ●
(3) Press the CHECK button (BS3) once.	☀ ● ● ● ● ● ⚡ ●
(4) Press the OPERATE button (BS2) once.	☀ ● ● ● ● ● ● ⚡ (Factory setting)
(5) Press the CHECK button (BS3) twice.	☀ ● ● ● ● ● ● ●
(6) Press the PAGE button (BS1) once.	● ● ☀ ● ● ● ● ●

3.2.10 Prevention of Micro Heating in Non-operating Unit

In heating operation, this setting is made to prevent room temperature from rising due to micro heating capacity generated in the unit with its heating thermostat OFF or in the unit with its heating operation stopped.

- By switching the BS units to cooling when the system turns OFF the heating thermostat or stops heating operation, micro heating is prevented.
- By enabling the micro heating prevention setting of the outdoor unit, prevention of micro heating of all BS units connected to the outdoor unit is enabled. (Default setting of BS unit)
- Setting by BS unit is enabled by changing the micro heating prevention setting of every BS unit. (In this case, enable the outdoor unit setting.)

3.2.11 Reduction of Cooling/Heating Selection Time of BS Units

Make this setting to reduce selection time between cooling and heating of the BS units, with careful attention paid to the following points.

- This setting is only enabled in case the refrigerant piping length between every BS unit connected to the outdoor unit and the indoor unit is not more than 10 m. (Refer to the figure shown below: $(a) \leq 10$ m and $(b)+(c) \leq 10$ m and ...)
- In case the refrigerant piping length between the BS units and the indoor units is long, refrigerant passing sounds may become louder when the BS unit selects operation mode between cooling and heating.
- This setting reduces the operation mode selection time in all the BS units within the same refrigerant circuit.

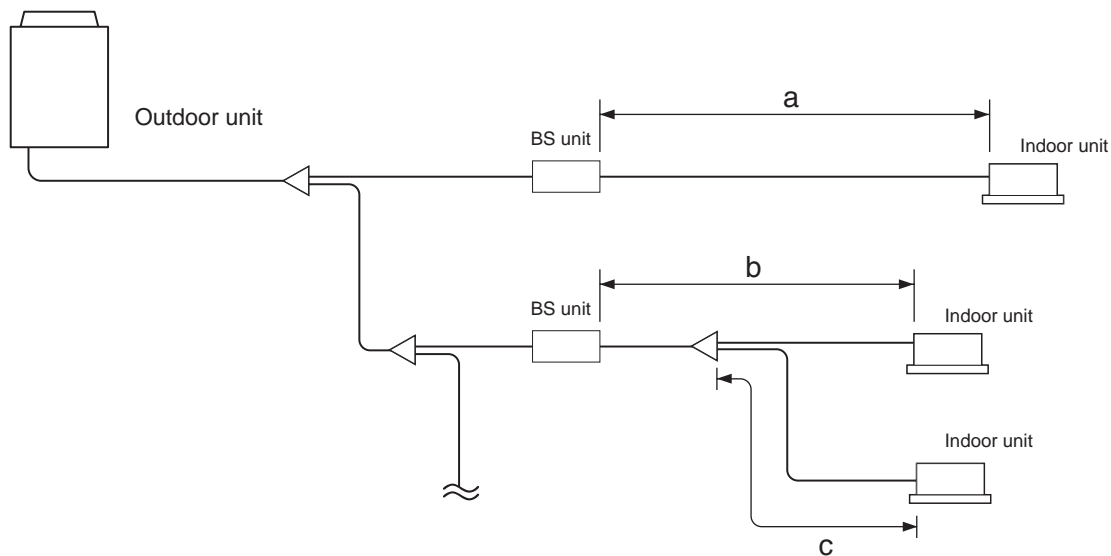

Part 6

Troubleshooting

1. Symptom-based Troubleshooting	212
2. Troubleshooting by Remote Control	215
2.1 The INSPECTION / TEST Button.....	215
2.2 Self-diagnosis by Wired Remote Control	216
2.3 Self-diagnosis by Infrared Remote Control	217
2.4 Inspection Mode	220
2.5 Remote Control Service Mode	221
2.6 Test Run Mode.....	223
2.7 Remote Control Self-Diagnosis Function	223
3. Troubleshooting by Indication on the Remote Control	230
3.1 "R0" Indoor Unit: Error of External Protection Device	230
3.2 "R1" Indoor Unit: PC Board Defect.....	231
3.3 "R3" Indoor Unit: Malfunction of Drain Level Control System (S1L)	232
3.4 "R5" Indoor Unit: Fan Motor (M1F) Lock, Overload.....	234
"R5" Indoor Unit: Malfunction of Indoor Unit Fan Motor.....	236
"R5" Indoor Unit: Overload / Overcurrent /	
Lock of Indoor Unit Fan Motor	237
3.5 "R7" Indoor Unit: Malfunction of Swing Flap Motor (M1S)	238
3.6 "R9" Indoor Unit: Electronic Expansion Valve Malfunction /	
Dust Clogging.....	240
"R9" Indoor Unit: Malfunction of Electronic Expansion Valve Coil.....	242
3.7 "RF" Indoor Unit: Drain Level above Limit.....	244
3.8 "RJ" Indoor Unit: Malfunction of Capacity Determination Device	245
3.9 "C4" Indoor Unit: Malfunction of Thermistor (R2T) for	
Heat Exchanger.....	246
3.10 "C5" Indoor Unit: Malfunction of Thermistor (R3T) for Gas Pipes.....	247
3.11 "C9" Indoor Unit: Malfunction of Thermistor (R1T) for Suction Air.....	248
3.12 "CJ" Indoor Unit: Malfunction of Thermostat Sensor in	
Remote Control	249
3.13 "E1" Outdoor Unit: PC Board Defect	250
3.14 "E3" Outdoor Unit: Actuation of High Pressure Switch	251
3.15 "E4" Outdoor Unit: Actuation of Low Pressure Sensor	253
3.16 "E5" Outdoor Unit: Inverter Compressor Motor Lock.....	255
3.17 "E6" Outdoor Unit: STD Compressor Motor Overcurrent/Lock.....	257
3.18 "E7" Outdoor Unit: Malfunction of Outdoor Unit Fan Motor	258
3.19 "E9" Outdoor Unit: Malfunction of Moving Part of	
Electronic Expansion Valve (Y1E~Y5E).....	261
3.20 "F3" Outdoor Unit: Abnormal Discharge Pipe Temperature	263
3.21 "F6" Outdoor Unit: Refrigerant Overcharged.....	265
3.22 "F9" Outdoor Unit: Malfunction of BS Unit Electronic	
Expansion Valve.....	266
3.23 "H7" Outdoor Unit: Abnormal Outdoor Fan Motor Signal.....	268
3.24 "H9" Outdoor Unit: Malfunction of Thermistor (R1T) for	
Outdoor Air	270
3.25 "J2" Outdoor Unit: Current Sensor Malfunction	271

3.26 “J3” Outdoor Unit: Malfunction of Discharge Pipe Thermistor (R31, 32T, 33T).....	272
3.27 “J4” Outdoor Unit: Malfunction of Temperature Sensor for Heat Exchanger Gas (R2T or R11T).....	273
3.28 “J5” Outdoor Unit: Malfunction of Thermistor (R8T or R10T) for Suction Pipe	274
3.29 “J6” Outdoor Unit: Malfunction of Thermistor (R4T or R12T) for Outdoor Unit Heat Exchanger	275
3.30 “J7” Outdoor Unit: Malfunction of Liquid Pipe Thermistor 1 (R6T), (R9T) or (R14T).....	276
3.31 “J8” Outdoor Unit: Malfunction of Liquid Pipe Thermistor 2 (R7T or R15T)	277
3.32 “J9” Outdoor Unit: Malfunction of Subcooling Heat Exchanger Gas Pipe Thermistor (R5T or R13T)	278
3.33 “JR” Outdoor Unit: Malfunction of High Pressure Sensor.....	279
3.34 “JL” Outdoor Unit: Malfunction of Low Pressure Sensor.....	281
3.35 “L1” Outdoor Unit: Defective Inverter PC Board	283
3.36 “L4” Outdoor Unit: Malfunction of Inverter Radiating Fin Temperature Rise.....	285
3.37 “L5” Outdoor Unit: Momentary Overcurrent of Inverter Compressor.....	288
3.38 “L8” Outdoor Unit: Momentary Overcurrent of Inverter Compressor.....	290
3.39 “L9” Outdoor Unit: Inverter Compressor Starting Failure	292
3.40 “LL” Outdoor Unit: Malfunction of Transmission between Inverter and Control PC Board	295
3.41 “P1” Outdoor Unit: Inverter Over-Ripple Protection	298
3.42 “P4” Outdoor Unit: Malfunction of Inverter Radiating Fin Temperature Rise Sensor	300
3.43 “PJ” Outdoor Unit: Faulty Field Setting after Replacing Main PC Board or Faulty Combination of PC Board	302
3.44 “UD” Outdoor Unit: Gas Shortage Alert	304
3.45 “U1” Reverse Phase, Open Phase.....	306
3.46 “U2” Outdoor Unit: Power Supply Insufficient or Instantaneous Failure.....	307
3.47 “U3” Outdoor Unit: Check Operation not Executed	310
3.48 “U4” Malfunction of Transmission between Indoor Units.....	311
3.49 “U5” Indoor Unit: Malfunction of Transmission between Remote Control and Indoor Unit.....	314
3.50 “U7” Outdoor Unit: Transmission Failure (Across Outdoor Units)	315
3.51 “UB” Indoor Unit: Malfunction of Transmission between Main and Sub Remote Controls	321
3.52 “US” Indoor Unit: Malfunction of Transmission between Indoor and Outdoor Units in the Same System	322
3.53 “UR” Improper Combination of Indoor and Outdoor Units, Indoor Units and Remote Control.....	323
3.54 “UL” Address Duplication of Centralized Controller	329
3.55 “UE” Malfunction of Transmission between Centralized Controller and Indoor Unit.....	330
3.56 “UF” System is not Set yet.....	333
3.57 “UH” Malfunction of System, Refrigerant System Address Undefined	334

4. Troubleshooting (OP: Central Remote Control)	336
4.1 “77” PC Board Defect	336
4.2 “78” Malfunction of Transmission between Optional Controllers for Centralized Control.....	337
4.3 “79” Improper Combination of Optional Controllers for Centralized Control.....	338
4.4 “7C” Address Duplication, Improper Setting	340
5. Troubleshooting (OP: Unified ON/OFF Controller)	341
5.1 Operation Lamp Blinks	341
5.2 Display “Under Centralized Control” Blinks (Repeats Single Blink)	343
5.3 Display “Under Centralized Control” Blinks (Repeats Double Blink)	346

1. Symptom-based Troubleshooting

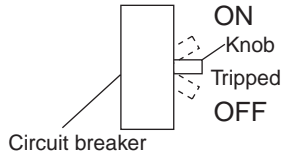
	Symptom	Supposed Cause	Countermeasure	
1	The system does not start operation at all.	Blowout of fuse(s)	Turn Off the power supply and then replace the fuse(s).	
		Cutout of breaker(s)	<ul style="list-style-type: none"> If the knob of any breaker is in its OFF position, turn ON the power supply. If the knob of any circuit breaker is in its tripped position, do not turn ON the power supply.  <p>The diagram shows a vertical rectangular circuit breaker. To its right is a horizontal knob. Three dashed arrows point to the knob's positions: 'ON' at the top, 'Tripped' in the middle, and 'OFF' at the bottom. A label 'Circuit breaker' points to the main body of the breaker.</p>	
		Power failure	After the power failure is reset, restart the system.	
2	The system starts operation but makes an immediate stop.	Blocked air inlet or outlet of indoor or outdoor unit	Remove obstacle(s).	
		Clogged air filter(s)	Clean the air filter(s).	
3	The system does not cool or heat air well.	Blocked air inlet or outlet of indoor or outdoor unit	Remove obstacle(s).	
		Clogged air filter(s)	Clean the air filter(s).	
		Enclosed outdoor unit(s)	Remove the enclosure.	
		Improper set temperature	Set the temperature to a proper degree.	
		Airflow rate set to "LOW"	Set it to a proper airflow rate.	
		Improper direction of air diffusion	Set it to a proper direction.	
		Open window(s) or door(s)	Shut it tightly.	
		[In cooling] Direct sunlight received	Hang curtains or shades on windows.	
		[In cooling] Too many persons staying in a room		
[In cooling] Too many heat sources (e.g. OA equipment) located in a room				
4	The system does not operate.	The system stops and immediately restarts operation.	If the OPERATION lamp on the remote control turns ON, the system will be normal. These symptoms indicate that the system is controlled so as not to put unreasonable loads on the system.	
		Pressing the TEMP ADJUST button immediately resets the system.		
		The remote control displays "UNDER CENTRALIZED CONTROL", which blinks for a period of several seconds when the OPERATION button is depressed.	The system is controlled with centralized controller. Blinking display indicates that the system cannot be operated using the remote control.	Operate the system using the COOL/HEAT centralized remote control.
		The system stops immediately after turning ON the power supply.	The system is in preparation mode of micro computer operation.	Wait for a period of approximately one minute.
5	The system makes intermittent stops.	The remote control displays malfunction codes "U4" and "U5", and the system stops but restarts after a lapse of several minutes.	The system stops due to an interruption in communication between units caused by electrical noises coming from equipment other than air conditioners.	Remove causes of electrical noises. If these causes are removed, the system will automatically restart operation.
6	COOL-HEAT selection is disabled.	The remote control displays "UNDER CENTRALIZED CONTROL".	This remote control has no option to select cooling operation.	Use a remote control with option to select cooling operation.
		The remote control displays "UNDER CENTRALIZED CONTROL", and the COOL-HEAT selection remote control is provided.	COOL-HEAT selection is made using the COOL-HEAT selection remote control.	Use the COOL-HEAT selection remote control to select cool or heat.

	Symptom		Supposed Cause	Countermeasure
7	The system conducts fan operation but not cooling or heating operation.	This symptom occurs immediately after turning ON the power supply.	The system is in preparation mode of operation.	Wait for a period of approximately 10 minutes.
8	The airflow rate is not reproduced according to the setting.	Even pressing the AIRFLOW RATE SET button makes no changes in the airflow rate.	In heating operation, when the room temperature reaches the set degree, the outdoor unit will stop while the indoor unit is brought to fan LL operation so that no one gets cold air. Furthermore, if fan operation mode is selected when other indoor unit is in heating operation, the system will be brought to fan LL operation. (The fan LL operation is also enabled while in oil return mode in cooling operation.)	Normal operation.
9	The airflow direction is not reproduced according to the setting.	The airflow direction is not corresponding to that displayed on the remote control. The flap does not swing.	Automatic control	Normal operation.
10	A white mist comes out from the system.	<Indoor unit> In cooling operation, the ambient humidity is high. (This indoor unit is installed in a place with much oil or dust.)	Uneven temperature distribution due to heavy stain of the inside of the indoor unit	Clean the inside of the indoor unit.
		<Indoor unit> Immediately after cooling operation stopping, the ambient temperature and humidity are low.	Hot gas (refrigerant) flown in the indoor unit results to be vapor from the unit.	Normal operation.
		<Indoor and outdoor units> After the completion of defrosting operation, the system is switched to heating operation.	Defrosted moisture turns to be vapor and comes out from the units.	Normal operation.
11	The system produces sounds.	<Indoor unit> Immediately after turning ON the power supply, indoor unit produces "ringing" sounds.	These are operating sounds of the electronic expansion valve of the indoor unit.	Normal operation. This sound becomes low after a lapse of approximately one minute.
		<Indoor and outdoor units> "Hissing" sounds are continuously produced while in cooling or defrosting operation.	These sounds are produced from gas (refrigerant) flowing respectively through the indoor and outdoor units.	Normal operation.
		<Indoor and outdoor units> "Hissing" sounds are produced immediately after the startup or stop of the system, or the startup or stop of defrosting operation.	These sounds are produced when the gas (refrigerant) stops or changes flowing.	Normal operation.
		<Indoor unit> Faint sounds are continuously produced while in cooling operation or after stopping the operation.	These sounds are produced from the drain discharge device in operation.	Normal operation.
		<Indoor unit> "Creaking" sounds are produced while in heating operation or after stopping the operation.	These sounds are produced from resin parts expanding and contracting with temperature changes.	Normal operation.
		<Indoor unit> Sounds like "trickling" or the like are produced from indoor units in the stopped state.	On VRV systems, these sounds are produced when other indoor units in operation. The reason is that the system runs in order to prevent oil or refrigerant from dwelling.	Normal operation.
		<Outdoor unit> Pitch of operating sounds changes.	The reason is that the compressor changes the operating frequency.	Normal operation.

	Symptom		Supposed Cause	Countermeasure
12	Dust comes out from the system.	Dust comes out from the system when it restarts after the stop for an extended period of time.	Dust, which has deposited on the inside of indoor unit, is blown out from the system.	Normal operation.
13	Odors come out from the system.	In operation	Odors of room, cigarettes or else adsorbed to the inside of indoor unit are blown out.	The inside of the indoor unit should be cleaned.
14	Outdoor unit fan does not rotate.	In operation	The reason is that fan revolutions are controlled to put the operation to the optimum state.	Normal operation.
15	LCD display "88" appears on the remote control.	Immediately after turning ON the power supply	The reason is that the system is checking to be sure the remote control is normal.	Normal operation. This code is displayed for a period of approximately one minute at maximum.
16	The outdoor unit compressor or the outdoor unit fan does not stop.	After stopping operation	It stops in order to prevent oil or refrigerant from dwelling.	Normal operation. It stops after a lapse of approximately 5 to 10 minutes.
17	The outdoor gets hot.	While stopping operation	The reason is that the compressor is warmed up to provide smooth startup of the system.	Normal operation.
18	Hot air comes out from the system even though it stops.	Hot air is felt while the system stops.	On VRV systems, small quantity of refrigerant is fed to indoor units in the stopped state when other indoor units are in operation.	Normal operation.
19	The system does not cool air well.	The system is in dry operation.	The reason is that the dry operation serves not to reduce the room temperature where possible.	Change the system to cooling operation.

2. Troubleshooting by Remote Control

2.1 The INSPECTION / TEST Button

The following modes can be selected by using the [Inspection/Test Operation] button on the remote control.

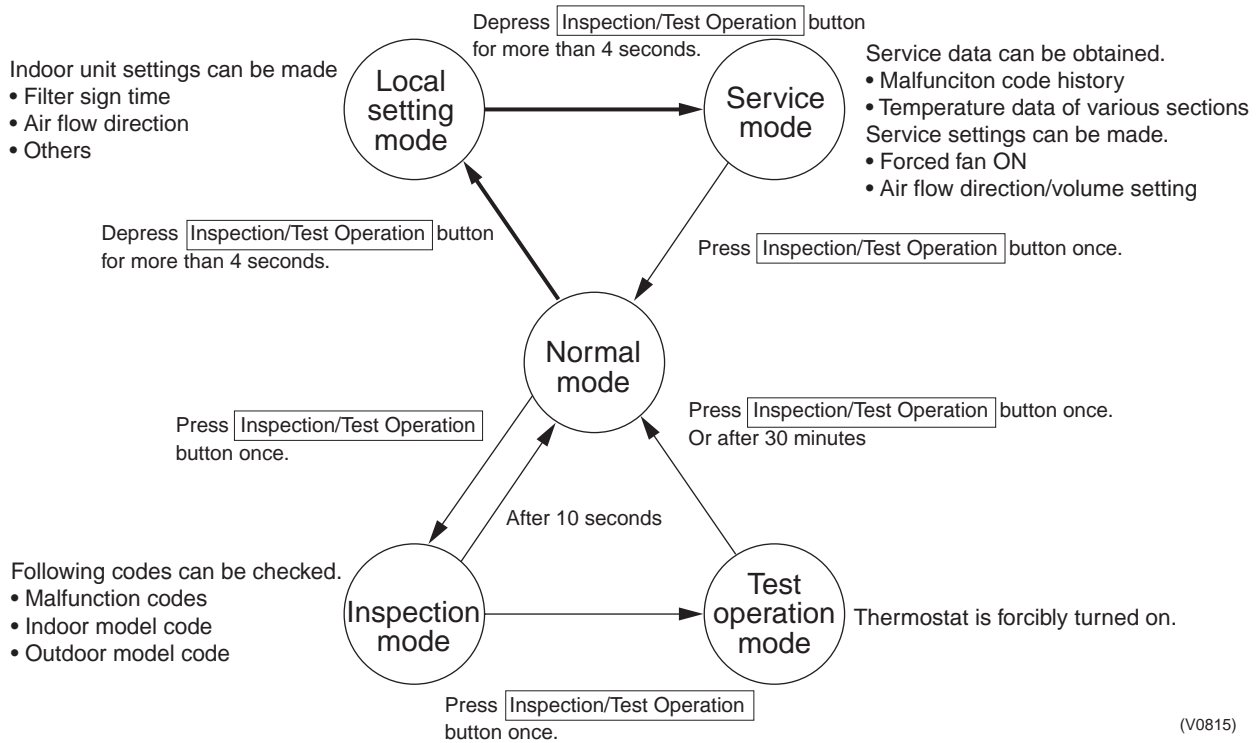

2.2 Self-diagnosis by Wired Remote Control

Explanation

If operation stops due to malfunction, the remote control's operation LED blinks, and malfunction code is displayed. (Even if stop operation is carried out, malfunction contents are displayed when the inspection mode is entered.) The malfunction code enables you to tell what kind of malfunction caused operation to stop. See page 224 for malfunction code and malfunction contents.

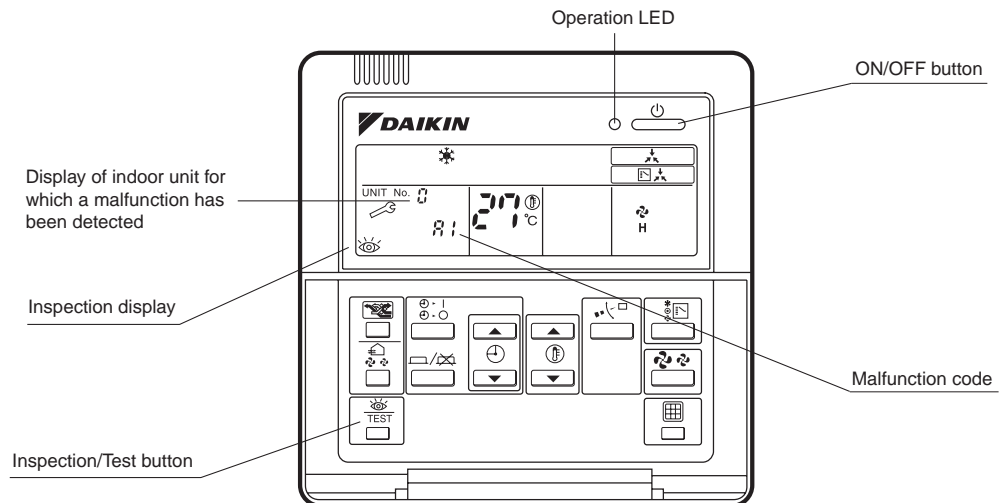

Note:

1. Pressing the INSPECTION/TEST button will blink the check indication.
2. While in check mode, pressing and holding the ON/OFF button for a period of five seconds or more will clear the failure history indication shown above. In this case, on the codes display, the malfunction code will blink twice and then change to "00" (=Normal), the Unit No. will change to "0", and the operation mode will automatically switch from check mode to normal mode (displaying the set temperature).

2.3 Self-diagnosis by Infrared Remote Control

**In the Case of
BRC7C Type
BRC7E Type
BRC4C Type**

If equipment stops due to a malfunction, the operation indicating LED on the light reception section flashes.

The malfunction code can be determined by following the procedure described below. (The malfunction code is displayed when an operation error has occurred. In normal condition, the malfunction code of the last problem is displayed.)

1. Press the INSPECTION/TEST button to select "Inspection."
The equipment enters the inspection mode. The "Unit" indication lights and the Unit No. display shows flashing "0" indication.
2. Set the Unit No.
Press the UP or DOWN button and change the Unit No. display until the buzzer (*1) is generated from the indoor unit.
*1 Number of beeps
3 short beeps : Conduct all of the following operations.
1 short beep : Conduct steps 3 and 4.
Continue the operation in step 4 until a buzzer remains ON. The continuous buzzer indicates that the malfunction code is confirmed.
Continuous beep : No abnormality.
3. Press the MODE selector button.
The left "0" (upper digit) indication of the malfunction code flashes.
4. Malfunction code upper digit diagnosis
Press the UP or DOWN button and change the malfunction code upper digit until the malfunction code matching buzzer (*2) is generated.

- The upper digit of the code changes as shown below when the UP and DOWN buttons are pressed.



*2 Number of beeps

Continuous beep : Both upper and lower digits matched. (Malfunction code confirmed)

2 short beeps : Upper digit matched.

1 short beep : Lower digit matched.

5. Press the MODE selector button.
The right "0" (lower digit) indication of the malfunction code flashes.
6. Malfunction code lower digit diagnosis
Press the UP or DOWN button and change the malfunction code lower digit until the continuous malfunction code matching buzzer (*2) is generated.

- The lower digit of the code changes as shown below when the UP and DOWN buttons are pressed.



⇒ “Advance” button ← “Backward” button (SE007)

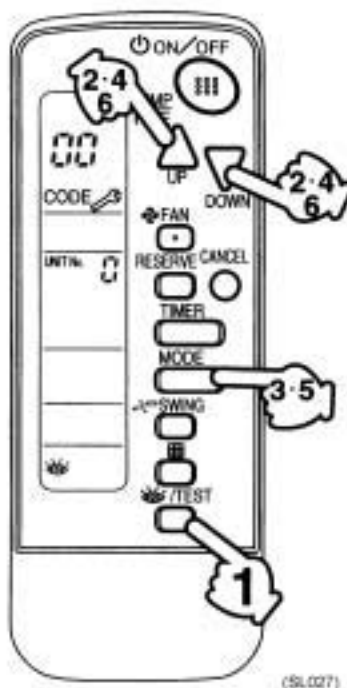

(SL027)

Normal status
Enters inspection mode from normal status when the INSPECTION/TEST button is pressed.

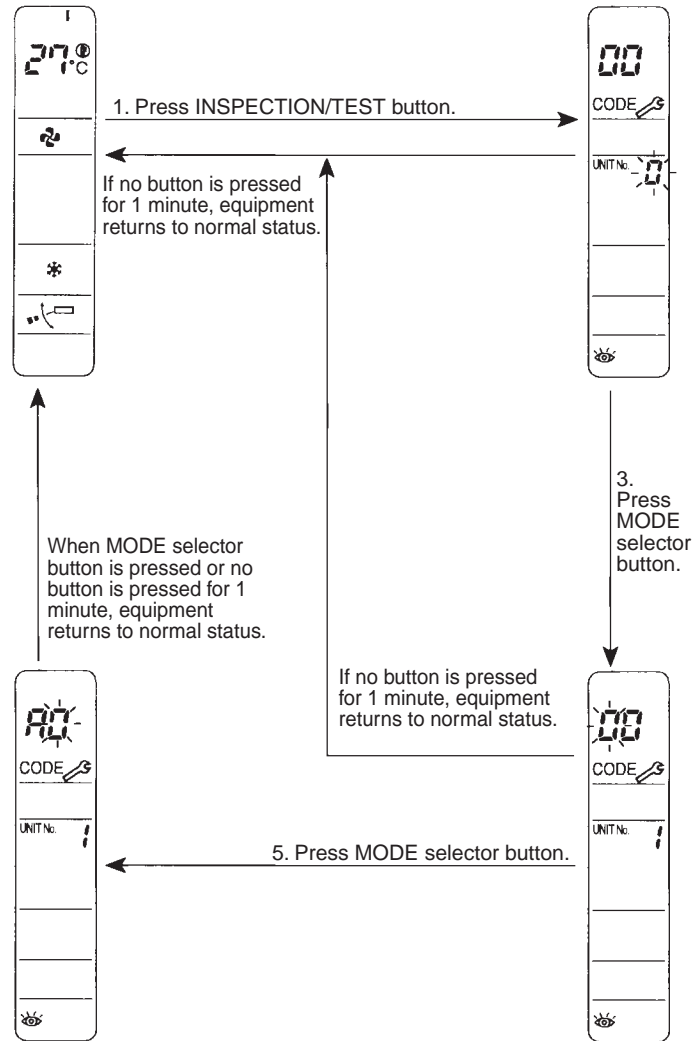

(SF008)

2.4 Inspection Mode

Operating the **INSPECTION/TEST** button on the remote control will make it possible to check the malfunction codes, indoor unit model codes, and outdoor unit model codes while in inspection mode.

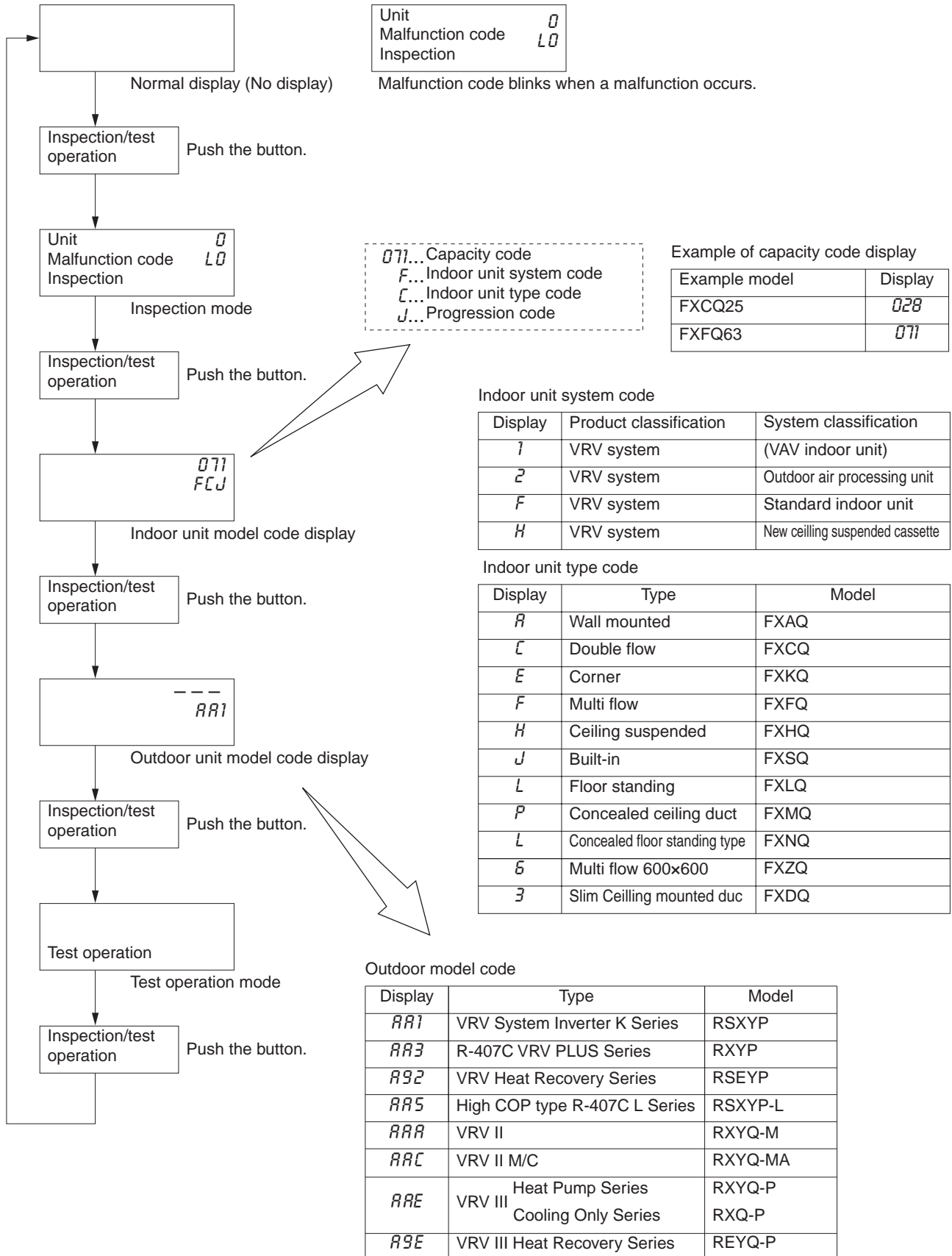

(V2775)

2.5 Remote Control Service Mode

Operating the **CHECK/TEST** button on the remote control will make it possible to obtain "service data" and change "service setting" while in service mode.

How to Enter the Service Mode

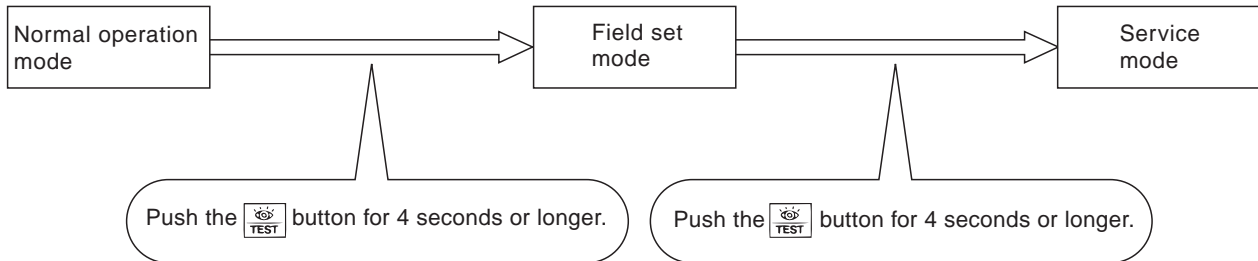

(VF020)

Service Mode Operation Method

1. Select the mode No.

Set the desired mode No. with the **MODE** button.
(For infrared remote control, Mode 43 only can be set.)

2. Select the unit No. (For group control only)

Select the indoor unit No. to be set with the time mode **TIME** button.)

3. Make the settings required for each mode. (Modes 41, 44, 45)

In case of Mode 44, 45, push **ENTER** button to be able to change setting before setting work.
(LCD "code" blinks.)









For details, refer to the table in next page.

4. Define the setting contents. (Modes 44, 45)

Define by pushing the timer **TIMER** button.
After defining, LCD "code" changes blinking to ON.

5. Return to the normal operation mode.

Push the **CHECK/TEST** button one time.

Mode No	Function	Contents and operation method	Remote control display example
40	Malfunction hysteresis display	<p>Display malfunction hysteresis.</p> <p>The history No. can be changed with the  button.</p>	<p>Unit 1 Malfunction code 40</p> <p>2-04 Malfunction code</p> <p>History No: 1 - 9 1: Latest</p> <p>(VE007)</p>
41	Display of sensor and address data	<p>Display various types of data.</p> <p>Select the data to be displayed with the  button. Sensor data 0: Thermostat sensor in remote control. 1: Suction 2: Liquid pipe 3: Gas pipe</p> <p>Address data 4: Indoor unit address 5: Outdoor unit address 6: BS unit address 7: Zone control address 8: Cool/heat group address 9: Demand / low noise address</p>	<p>Sensor data display</p> <p>Unit No. Sensor type</p> <p>1 1</p> <p>2 7 41</p> <p>Temperature °C</p> <p>Address display</p> <p>Unit No. Address type</p> <p>1 8</p> <p>41</p> <p>Address</p> <p>(VE008)</p>
43	Forced fan ON	<p>Manually turn the fan ON by each unit. (When you want to search for the unit No.)</p> <p>By selecting the unit No. with the  button, you can turn the fan of each indoor unit on (forced ON) individually.</p>	<p>Unit 1</p> <p>43</p> <p>(VE009)</p>
44	Individual setting	<p>Set the fan speed and air flow direction by each unit</p> <p>Select the unit No. with the time mode  button. Set the fan speed with the  button.</p> <p>Set the air flow direction with the  button.</p>	<p>Unit 1</p> <p>Code 44</p> <p>13</p> <p>Fan speed 1: Low 3: High</p> <p>Air flow direction P0 - P4</p> <p>(VE010)</p>
45	Unit No. transfer	<p>Transfer unit No.</p> <p>Select the unit No. with the  button. Set the unit No. after transfer with the  button.</p>	<p>Present unit No.</p> <p>Unit 1 Code 45</p> <p>02</p> <p>Unit No. after transfer</p> <p>(VE011)</p>
46	This function is not used by VRV III R-410A Heat Recovery 50Hz.		
47			

2.6 Test Run Mode

Operating the **INSPECTION/TEST** button on the remote control will make it possible to put the system into test run mode.

(1) Test run mode setting

The test run mode setting can be made by conducting the following operation.

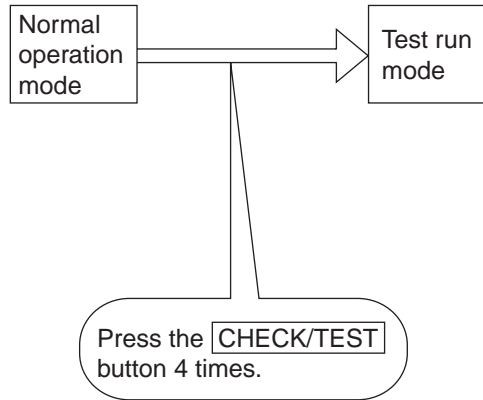

Press the **RUN/STOP** button after the completion of test run mode setting, and a test run starts.

(The remote control will display "TEST RUN" on it.)

2.7 Remote Control Self-Diagnosis Function

The remote control switches are equipped with a self diagnosis function so that more appropriate maintenance can be carried out. If a malfunction occurs during operation, the operation lamp, malfunction code and display of malfunctioning unit No. let you know the contents and location of the malfunction.

When there is a stop due to malfunction, the contents of the malfunction given below can be diagnosed by a combination of operation lamp, INSPECTION display of the liquid crystal display and display of malfunction code. It also lets you know the unit No. during group control.

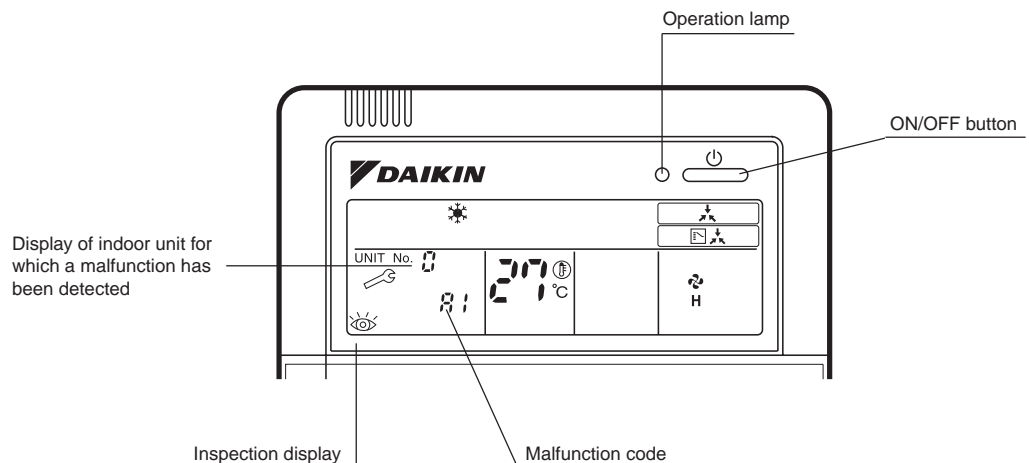

(VL050)

○: ON ●: OFF ◐: Blink

	Malfunction code	Operation lamp	Inspection display	Unit No.	Malfunction contents	Page Referred
Indoor Unit	A0	◐	◐	◐	Error of external protection device	230
	A1	◐	◐	◐	PC board defect, E ² PROM defect	231
	A3	◐	◐	◐	Malfunction of drain level control system (S1L)	232
	A6	◐	◐	◐	Fan motor (M1F) lock, overload	234 236 237
	A7	○	●	◐	Malfunction of swing flap motor (M1S)	238
	A9	◐	◐	◐	Malfunction of moving part of electronic expansion valve / Dust clogging	240 242
	AF	○	●	◐	Drain level about limit	244
	AH	○	●	◐	Malfunction of air filter maintenance	—
	AJ	◐	◐	◐	Malfunction of capacity setting	245
	C4	◐	◐	◐	Malfunction of thermistor (R2T) for heat exchange (loose connection, disconnection, short circuit, failure)	246
	C5	◐	◐	◐	Malfunction of thermistor (R3T) for gas pipes (loose connection, disconnection, short circuit, failure)	247
	C9	◐	◐	◐	Malfunction of thermistor (R1T) for air inlet (loose connection, disconnection, short circuit, failure)	248
	CJ	○	○	○	Malfunction of thermostat sensor in remote control	249
	Outdoor Unit	E1	◐	◐	◐	PC board defect
E3		◐	◐	◐	Actuation of high pressure switch	251
E4		◐	◐	◐	Actuation of low pressure sensor	253
E5		◐	◐	◐	Compressor motor lock	255
E6		◐	◐	◐	Standard compressor lock or over current	257
E7		◐	◐	◐	Malfunction of outdoor unit fan motor	258
E9		◐	◐	◐	Malfunction of moving part of electronic expansion valve (Y1E, Y2E, Y3E)	261
F3		◐	◐	◐	Abnormal discharge pipe temperature	263
F6		◐	◐	◐	Refrigerant overcharged	265
F9		◐	◐	◐	Malfunction of BS unit electronic expansion valve	266
H7		◐	◐	◐	Abnormal outdoor fan motor signal	268
H9		◐	◐	◐	Malfunction of thermistor (R1T) for outdoor air (loose connection, disconnection, short circuit, failure)	270
J2		◐	◐	◐	Current sensor malfunction	271
J3		◐	◐	◐	Malfunction of discharge pipe thermistor (R31, 32T, 33T) (loose connection, disconnection, short circuit, failure)	272
J4		◐	◐	◐	Malfunction of temperature sensor for heat exchanger gas (R2T)	273
J5		◐	◐	◐	Malfunction of thermistor (R8T) for suction pipe (loose connection, disconnection, short circuit, failure)	274
J6		◐	◐	◐	Malfunction of thermistor (R4T) for heat exchanger (loose connection, disconnection, short circuit, failure)	275
J7		◐	◐	◐	Malfunction of receiver outlet liquid pipe thermistor (R6T), (9T)	276
J8		◐	◐	◐	Malfunction of liquid pipe thermistor 2 (R7T)	277
J9		◐	◐	◐	Malfunction of subcooling heat exchanger gas pipe thermistor (R5T)	278
JA		◐	◐	◐	Malfunction of high pressure sensor	279
JC		◐	◐	◐	Malfunction of low pressure sensor	281
L1		◐	◐	◐	Malfunction of inverter PC board	283
L4		◐	◐	◐	Malfunction of inverter radiating fin temperature rise	285
L5		◐	◐	◐	DC output overcurrent of inverter compressor	288
L8		◐	◐	◐	Inverter current abnormal	290
L9		◐	◐	◐	Inverter start up error	292

○: ON ●: OFF ◐: Blink

	Malfunction code	Operation lamp	Inspection display	Unit No.	Malfunction contents	Page Referred
Outdoor Unit	LA	◐	◐	◐	Malfunction of power unit	—
	LC	◐	◐	◐	Malfunction of transmission between inverter and control PC board	295
	P1	◐	◐	◐	Inverter over-ripple protection	298
	P4	◐	◐	◐	Malfunction of inverter radiating fin temperature rise sensor	300
	PJ	◐	◐	◐	Faulty field setting after replacing main PC board or faulty combination of PC board	302
System	U0	○	●	◐	Gas shortage alert	304
	U1	◐	◐	◐	Reverse phase / open phase	306
	U2	◐	◐	◐	Power supply insufficient or instantaneous failure	307
	U3	◐	◐	◐	Check operation is not completed.	310
	U4	◐	◐	◐	Malfunction of transmission between indoor and outdoor units	311
	U5	◐	◐	◐	Malfunction of transmission between remote control and indoor unit	314
	U5	●	○	●	Failure of remote control PC board or setting during control by remote control	314
	U7	◐	◐	◐	Malfunction of transmission between outdoor units	315
	U8	◐	◐	●	Malfunction of transmission between main and sub remote controls (malfunction of sub remote control)	321
	U9	◐	◐	◐	Malfunction of transmission between indoor unit and outdoor unit in the same system	322
	UA	◐	◐	◐	Improper combination of indoor and outdoor units, indoor units and remote control	323
	UC	○	○	○	Address duplication of central remote control	329
	UE	◐	◐	◐	Malfunction of transmission between central remote control and indoor unit	330
	UF	◐	◐	◐	Refrigerant system not set, incompatible wiring / piping	333
	UH	◐	◐	◐	Malfunction of system, refrigerant system address undefined	334
Central Remote Control and Schedule Timer	M1	○ or ●	◐	◐	Central remote control PC board defect Schedule timer PC board defect	336
	M8	○ or ●	◐	◐	Malfunction of transmission between optional controllers for centralized control	337
	MA	○ or ●	◐	◐	Improper combination of optional controllers for centralized control	338
	MC	○ or ●	◐	◐	Address duplication, improper setting	340
Heat Reclaim Ventilation	64	○	●	◐	Indoor unit's air thermistor error	—
	65	○	●	◐	Outside air thermistor error	—
	6A	○	●	◐	Damper system alarm	—
	6A	◐	◐	◐	Damper system + thermistor error	—
	6F	○	●	◐	Malfunction of simple remote control	—
	6H	○	●	◐	Malfunction of door switch or connector	—
	94	◐	◐	◐	Internal transmission error	—

 The system operates for malfunction codes indicated in black squares, however, be sure to check and repair.

Malfunction code indication by outdoor unit PC board

<Monitor mode>

To enter the monitor mode, push the **MODE (BS1)** button when in "Setting mode 1".

* Refer to Page 195 for Monitor mode.

<Selection of setting item>

Push the **SET (BS2)** button and set the LED display to a setting item.

* Refer to Page 195 for Monitor mode.

<Confirmation of malfunction 1>

Push the **RETURN (BS3)** button once to display "First digit" of malfunction code.

<Confirmation of malfunction 2>

Push the **SET (BS2)** button once to display "Second digit" of malfunction code.

<Confirmation of malfunction 3>

Push the **SET (BS2)** button once to display "malfunction location".

<Confirmation of malfunction 4>

Push the **SET (BS2)** button once to display "master or slave 1 or slave 2" and "malfunction location".

Push the **RETURN (BS3)** button and switches to the initial status of "Monitor mode".

* Push the **MODE (BS1)** button and returns to "Setting mode 1".

Detail description on next page.

Malfunctions		Malfunction code
Description of malfunction	Description of malfunction (PGF)	Remote control
PC board malfunction	PC board malfunction	E1
	Faulty PC board	
Abnormal discharge pressure	HPS activated	E3
Abnormal suction pressure	Pe malfunction	E4
Compressor lock	INV compressor lock detected	E5
OC activation	STD1 compressor lock detected	E6
	STD2 compressor lock detected	
Overload, overcurrent and abnormal lock of outdoor unit fan motor	Instantaneous overcurrent of 1DC fan motor	E7
	1DC fan motor lock detected	
	Fan 1 IPM faulty protection detected	
	Instantaneous overcurrent of 2DC fan motor	
	2DC fan motor lock detected	
Electronic expansion valve malfunction	EVM (main)	E9
	EVJ (refrigerant charging)	
	EVT (subcool heat exchanger)	
Positioning signal malfunction of outdoor unit fan motor	1DC fan motor positioning signal malfunction	H7
	2DC fan motor positioning signal malfunction	
Abnormal outdoor temperature	Ta sensor malfunction (short-circuited or open)	H9
Abnormal discharge pipe temperature	Td malfunction	F3
Abnormal heat exchanger temperature	Refrigerant overcharged	F6
BS unit electronic expansion valve malfunction	BS EVH disconnected (Y4E)	F9
	BS EVL disconnected (Y5E)	
	BS EVHS disconnected (Y2E)	
	BS EVLS disconnected (Y3E)	
	BS EVSC disconnected (Y1E)	
Current sensor malfunction	CT1 sensor malfunction (STD compressor 1)	J2
	CT2 sensor malfunction (STD compressor 2)	
	CT sensor malfunction (system)	
Discharge pipe temperature sensor malfunction	Tdi sensor malfunction (R31T)	J3
	Tds1 sensor malfunction (short-circuited) (R32T)	
	Tds2 sensor malfunction (short-circuited) (R33T)	
Heat exchanger gas temperature sensor malfunction	Tg sensor malfunction (R2T, R11T)	J4
Suction pipe temperature sensor malfunction	TsA sensor malfunction (short-circuited) (R8T, R10T)	J5
Heat exchanger temperature sensor malfunction	Tb sensor malfunction (R4T, R12T)	J6
Liquid pipe temperature sensor malfunction	Tsc sensor malfunction (R6T, R14T)	J7
	TL sensor malfunction (R9T)	
Heat exchanger liquid pipe temperature sensor malfunction	Tf sensor malfunction (R7T, R15T)	J8
Subcool heat exchanger temperature sensor malfunction	Tsh sensor malfunction (R5T, R13T)	J9
Discharge pressure sensor malfunction	Pc sensor malfunction (S1NPH)	JA
Suction pressure sensor malfunction	Pe sensor malfunction (S1NPL)	JC
INV PC board malfunction	Faulty IPM Current sensor failure confirmation 1 Current sensor failure confirmation 2 IGBT malfunction	L1
Rise in INV radiation fin temperature	Overheat of INV radiation fin temperature	L4
DC output overcurrent	Instantaneous overcurrent of INV	L5
	IGBT malfunction	
Electronic thermal	Electronic thermal 1	L8
	Electronic thermal 2	
	Loss of synchronization	
	Speed degradation after startup	
	Thunder detected	
Stall prevention (time limit)	Stall prevention (increased current)	L9
	Stall prevention (startup failure)	
	Abnormal starting waveform	
	Loss of synchronization	
INV transmission malfunction	INV transmission data malfunction	LC
	INV transmission malfunction	

○ : ON
 ● : Blink
 ● : OFF

○: ON ●: OFF ◐: Blink

Malfunction code	Confirmation of malfunction 1 (Check 1)							Confirmation of malfunction 2 (Check 2)							Confirmation of malfunction 3 (Check 3)							Confirmation of malfunction 4 (Check 4)						
	H1P	H2P	H3P	H4P	H5P	H6P	H7P	H1P	H2P	H3P	H4P	H5P	H6P	H7P	H1P	H2P	H3P	H4P	H5P	H6P	H7P	H1P	H2P	H3P	H4P	H5P	H6P	H7P
E1	○			●	●	○	○	○			●	●	●	○	○			●	●	●	●	○			●	●	○	○
E3								○			●	●	○	○	○			●	●	●	●	○			●	●	○	○
E4								○			●	○	○	○	○			●	●	●	●	○			●	●	○	○
E5								○			●	○	○	○	○			●	●	●	●	○			●	●	○	○
E6								○			●	○	○	○	○			●	●	●	●	○			●	●	○	○
E7								○			●	○	○	○	○			●	●	●	●	○			●	●	○	○
E9								○			○	●	●	○	○			●	●	●	●	○			○	○	○	○
H7	○			●	○	●	●	○			●	○	○	○	○			●	●	●	●	○			●	●	○	○
H9								○			○	●	●	○	○			●	●	●	●	○			○	○	○	○
F3	○			●	○	●	○	○			●	●	○	○	○			●	●	●	●	○			●	●	○	○
F6								○			○	○	○	○	○			●	●	●	●	○			○	○	○	○
F9								○			○	○	○	○	○			●	●	●	●	○			○	○	○	○
J2	○			●	○	○	●	○			●	●	○	○	○			●	●	●	●	○			○	○	○	○
J3								○			●	●	○	○	○			●	●	●	●	○			○	○	○	○
J4								○			●	○	○	○	○			●	●	●	●	○			○	○	○	○
J5								○			●	○	○	○	○			●	●	●	●	○			○	○	○	○
J6								○			●	○	○	○	○			●	●	●	●	○			○	○	○	○
J7								○			●	○	○	○	○			●	●	●	●	○			○	○	○	○
J8								○			○	○	○	○	○			●	●	●	●	○			○	○	○	○
J9								○			○	○	○	○	○			●	●	●	●	○			○	○	○	○
JA								○			○	○	○	○	○			●	●	●	●	○			○	○	○	○
JC								○			○	○	○	○	○			●	●	●	●	○			○	○	○	○
L1	○			●	○	○	○	○			●	●	○	○	○			●	●	●	●	○			○	○	○	○
L4								○			●	○	○	○	○			●	●	●	●	○			○	○	○	○
L5								○			●	○	○	○	○			●	●	●	●	○			○	○	○	○
L8								○			○	○	○	○	○			●	●	●	●	○			○	○	○	○
L9								○			○	○	○	○	○			●	●	●	●	○			○	○	○	○
LC								○			○	○	○	○	○			●	●	●	●	○			○	○	○	○

Display of contents of malfunction (first digit)

Display of contents of malfunction (second digit)

Display 1 of malfunction in detail

Display 2 of malfunction in detail

*1: Faulty system

<table border="1"> <tr><td>●</td><td>○</td></tr> <tr><td>○</td><td>○</td></tr> <tr><td>○</td><td>●</td></tr> <tr><td>○</td><td>○</td></tr> </table>	●	○	○	○	○	●	○	○	→ Individual system	<table border="1"> <tr><td>○</td><td>○</td></tr> <tr><td>○</td><td>○</td></tr> <tr><td>○</td><td>○</td></tr> <tr><td>○</td><td>○</td></tr> </table>	○	○	○	○	○	○	○	○	→ Multi system
●	○																		
○	○																		
○	●																		
○	○																		
○	○																		
○	○																		
○	○																		
○	○																		
<table border="1"> <tr><td>○</td><td>○</td></tr> <tr><td>○</td><td>○</td></tr> <tr><td>○</td><td>○</td></tr> <tr><td>○</td><td>○</td></tr> </table>	○	○	○	○	○	○	○	○	→ Right-hand system	<table border="1"> <tr><td>○</td><td>○</td></tr> <tr><td>○</td><td>○</td></tr> <tr><td>○</td><td>○</td></tr> <tr><td>○</td><td>○</td></tr> </table>	○	○	○	○	○	○	○	○	→ Master
○	○																		
○	○																		
○	○																		
○	○																		
○	○																		
○	○																		
○	○																		
○	○																		
<table border="1"> <tr><td>○</td><td>○</td></tr> <tr><td>○</td><td>○</td></tr> <tr><td>○</td><td>○</td></tr> <tr><td>○</td><td>○</td></tr> </table>	○	○	○	○	○	○	○	○	→ Left-hand system	<table border="1"> <tr><td>○</td><td>○</td></tr> <tr><td>○</td><td>○</td></tr> <tr><td>○</td><td>○</td></tr> <tr><td>○</td><td>○</td></tr> </table>	○	○	○	○	○	○	○	○	→ Slave 1
○	○																		
○	○																		
○	○																		
○	○																		
○	○																		
○	○																		
○	○																		
○	○																		
<table border="1"> <tr><td>○</td><td>○</td></tr> <tr><td>○</td><td>○</td></tr> <tr><td>○</td><td>○</td></tr> <tr><td>○</td><td>○</td></tr> </table>	○	○	○	○	○	○	○	○	→ —	<table border="1"> <tr><td>○</td><td>○</td></tr> <tr><td>○</td><td>○</td></tr> <tr><td>○</td><td>○</td></tr> <tr><td>○</td><td>○</td></tr> </table>	○	○	○	○	○	○	○	○	→ Slave 2
○	○																		
○	○																		
○	○																		
○	○																		
○	○																		
○	○																		
○	○																		
○	○																		
<table border="1"> <tr><td>○</td><td>○</td></tr> <tr><td>○</td><td>○</td></tr> <tr><td>○</td><td>○</td></tr> <tr><td>○</td><td>○</td></tr> </table>	○	○	○	○	○	○	○	○	→ All systems	<table border="1"> <tr><td>○</td><td>○</td></tr> <tr><td>○</td><td>○</td></tr> <tr><td>○</td><td>○</td></tr> <tr><td>○</td><td>○</td></tr> </table>	○	○	○	○	○	○	○	○	→ System
○	○																		
○	○																		
○	○																		
○	○																		
○	○																		
○	○																		
○	○																		
○	○																		

<Monitor mode>

To enter the monitor mode, push the **MODE (BS1)** button when in "Setting mode 1".

* Refer to Page 195 for Monitor mode.

<Selection of setting item>

Push the **SET (BS2)** button and set the LED display to a setting item.

* Refer to Page 195 for Monitor mode.

<Confirmation of malfunction 1>

Push the **RETURN (BS3)** button once to display "First digit" of malfunction code.

<Confirmation of malfunction 2>

Push the **SET (BS2)** button once to display "Second digit" of malfunction code.

<Confirmation of malfunction 3>

Push the **SET (BS2)** button once to display "malfunction location".

<Confirmation of malfunction 4>

Push the **SET (BS2)** button once to display "master or slave 1 or slave 2" and "malfunction location".

Push the **RETURN (BS3)** button and switches to the initial status of "Monitor mode".

* Push the **MODE (BS1)** button and returns to "Setting mode 1".

Detail description on next page.

Malfunctions		Malfunction code
Description of malfunction	Description of malfunction (PGF)	Remote control
Open phase and unbalanced power supply	Unbalanced INV power supply voltage	P1
INV radiation fin temperature sensor malfunction	INV fin thermistor malfunction	P4
Faulty combination of INV and fan driver	Faulty combination of INV	PJ
Out of gas	Out-of-gas alarm	U0
Reversed phase	Reversed phase malfunction	U1
	Reversed phase malfunction (ON)	
Abnormal power supply voltage	Insufficient INV voltage	U2
	INV open phase (single phase)	
	Abnormal charge of capacitor of INV main circuit	
Test run not carried out yet	Test run not carried out yet	U3
Faulty transmission between indoor and outdoor units	IN-OUT transmission malfunction	U4
	System malfunction	
Faulty transmission between outdoor units	Malfunction caused when mounting the external control adapter	U7
	Alarm given when mounting the external control adapter	
	Malfunction caused between the master and the slave 1	
	Malfunction caused between the master and the slave 2	
	Multi REYQ models connected	
	Faulty address setting of slaves 1 and 2	
	4 or more outdoor units connected in the same system	
Erroneous address of slaves 1 and 2		
Faulty transmission with other systems	Other system or other unit in the same system	U9
Faulty field setting	Excess indoor units connected	UA
	Erroneous refrigerant used for indoor unit	
	Faulty combination of outdoor units	
	Faulty independent installation	
	Faulty connection of former BS unit	
	Faulty connection between outdoor and BS unit	
	Faulty connection between BS units	
Wrong number of indoor units connected to BS unit		
Faulty system line	Wrong wiring (auto address error)	UH
Faulty transmission with accessory equipment	Multi level converter malfunction	UJ
	Multi level converter alarm	
	Multi level converter data malfunction	
	Multi level converter transmission malfunction	
Unmatched wiring/piping, no system settings	Unmatched wiring/piping	UF

○ : ON
 ● : Blink
 ● : OFF

○ : ON ● : OFF ◐ : Blink

Malfunction code	Confirmation of malfunction 1 (Check 1)							Confirmation of malfunction 2 (Check 2)							Confirmation of malfunction 3 (Check 3)							Confirmation of malfunction 4 (Check 4)						
	H1P	H2P	H3P	H4P	H5P	H6P	H7P	H1P	H2P	H3P	H4P	H5P	H6P	H7P	H1P	H2P	H3P	H4P	H5P	H6P	H7P	H1P	H2P	H3P	H4P	H5P	H6P	H7P
P1	◐	◐	●	◐	●	●	●	◐			●	●	●	◐	◐			●	●	●	●	◐			●	●		
P4								◐			●	◐	●	●	◐			●	●	●	●	◐			●	●		
PJ								◐			◐	◐	●	◐	◐			●	●	●	●	◐			●	●		
U0	◐	◐	●	◐	●	●	◐	◐			●	●	●	●	◐			●	●	●	●	◐			●	●	◐	◐
U1								◐			●	●	●	◐	◐			●	●	●	●	◐			●	●	●	●
U2								◐			●	●	◐	●	◐			●	●	●	●	◐			●	●	●	●
U3								◐			●	●	◐	◐	◐			●	●	●	●	◐			●	●	◐	◐
U4								◐			●	◐	●	●	◐			●	●	●	●	◐			●	●	◐	◐
U7								◐			●	◐	◐	◐	◐			●	●	●	●	◐			●	●	◐	◐
U9								◐			◐	●	●	◐	◐			●	●	●	●	◐			●	●	◐	◐
UA								◐			◐	●	◐	●	◐			●	●	●	●	◐			◐	●	◐	◐
UH								◐			◐	●	◐	◐	◐			●	●	●	●	◐			◐	●	◐	◐
UJ								◐			◐	◐	●	◐	◐			●	●	●	●	◐			◐	●	●	●
UF		◐	●					◐			◐	◐	◐	◐	◐			●	●	●	●	◐			●	●	◐	◐

Display of contents of malfunction (first digit)

Display of contents of malfunction (second digit)

Display 1 of malfunction in detail

Display 2 of malfunction in detail

*1: Faulty system

◐ ◐	→	Individual system	Multi system
● ●	→	Right-hand system	Master
● ◐	→	Left-hand system	Slave 1
◐ ●	→	—	Slave 2
◐ ◐	→	All systems	System

3. Troubleshooting by Indication on the Remote Control

3.1 "RD" Indoor Unit: Error of External Protection Device

Remote Control Display	RD
Applicable Models	All indoor unit models
Method of Malfunction Detection	Detect open or short circuit between external input terminals in indoor unit.
Malfunction Decision Conditions	When an open circuit occurs between external input terminals with the remote control set to "external ON/OFF terminal".
Supposed Causes	<ul style="list-style-type: none"> ■ Actuation of external protection device ■ Improper field set ■ Defect of indoor unit PC board

Troubleshooting



Caution

Be sure to turn off power switch before connect or disconnect connector, or parts damage may be occurred.

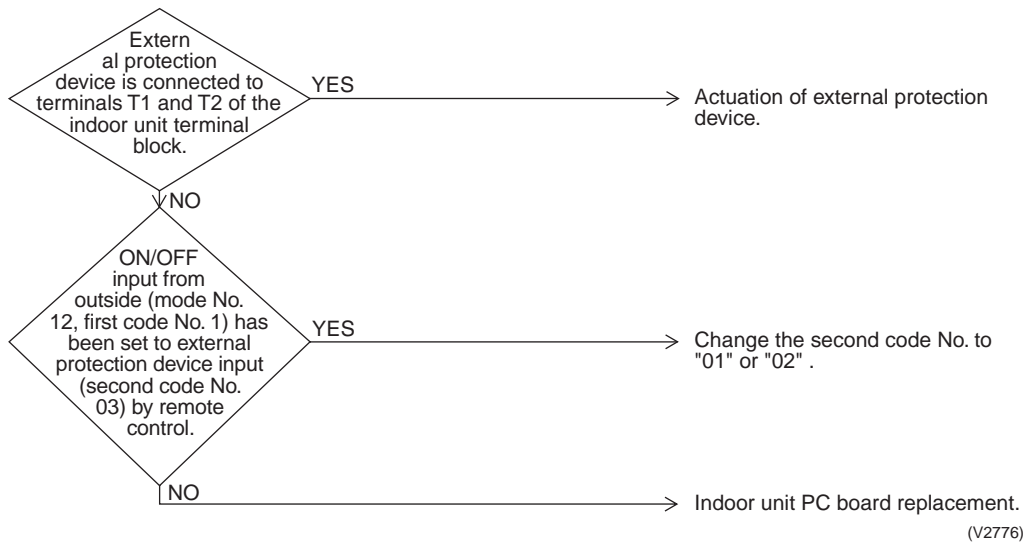

3.2 “A1” Indoor Unit: PC Board Defect

Remote Control Display	<i>A1</i>
Applicable Models	All indoor unit models
Method of Malfunction Detection	Check data from E ² PROM.
Malfunction Decision Conditions	When data could not be correctly received from the E ² PROM E ² PROM : Type of nonvolatile memory. Maintains memory contents even when the power supply is turned off.
Supposed Causes	<ul style="list-style-type: none"> ■ Defect of indoor unit PC board
Troubleshooting	<div style="text-align: center;">  <p>Caution Be sure to turn off power switch before connect or disconnect connector, or parts damage may be occurred.</p> </div> <pre> graph TD Start[Turn power supply OFF, then power ON again.] --> Decision{Does the system return to normal?} Decision -- YES --> YesOut[The indoor unit PC board is normal. External factor other than malfunction (for example, noise etc.).] Decision -- NO --> NoOut[Replace the indoor unit PC board.] </pre>

(V2777)

3.3 “R3” Indoor Unit: Malfunction of Drain Level Control System (S1L)

Remote Control Display	R3
Applicable Models	FXCQ, FXFQ, FXSQ, FXKQ, FXDQ, FXMQ, FXHQ (Option), FXMQ200,250M (Option), FXAQ (Option), FXMQ-MF (Option)
Method of Malfunction Detection	By float switch OFF detection
Malfunction Decision Conditions	When rise of water level is not a condition and the float switch goes OFF.
Supposed Causes	<ul style="list-style-type: none"> ■ 220~240V power supply is not provided ■ Defect of float switch or short circuit connector ■ Defect of drain pump ■ Drain clogging, upward slope, etc. ■ Defect of indoor unit PC board ■ Loose connection of connector

Troubleshooting



Caution Be sure to turn off power switch before connect or disconnect connector, or parts damage may be occurred.

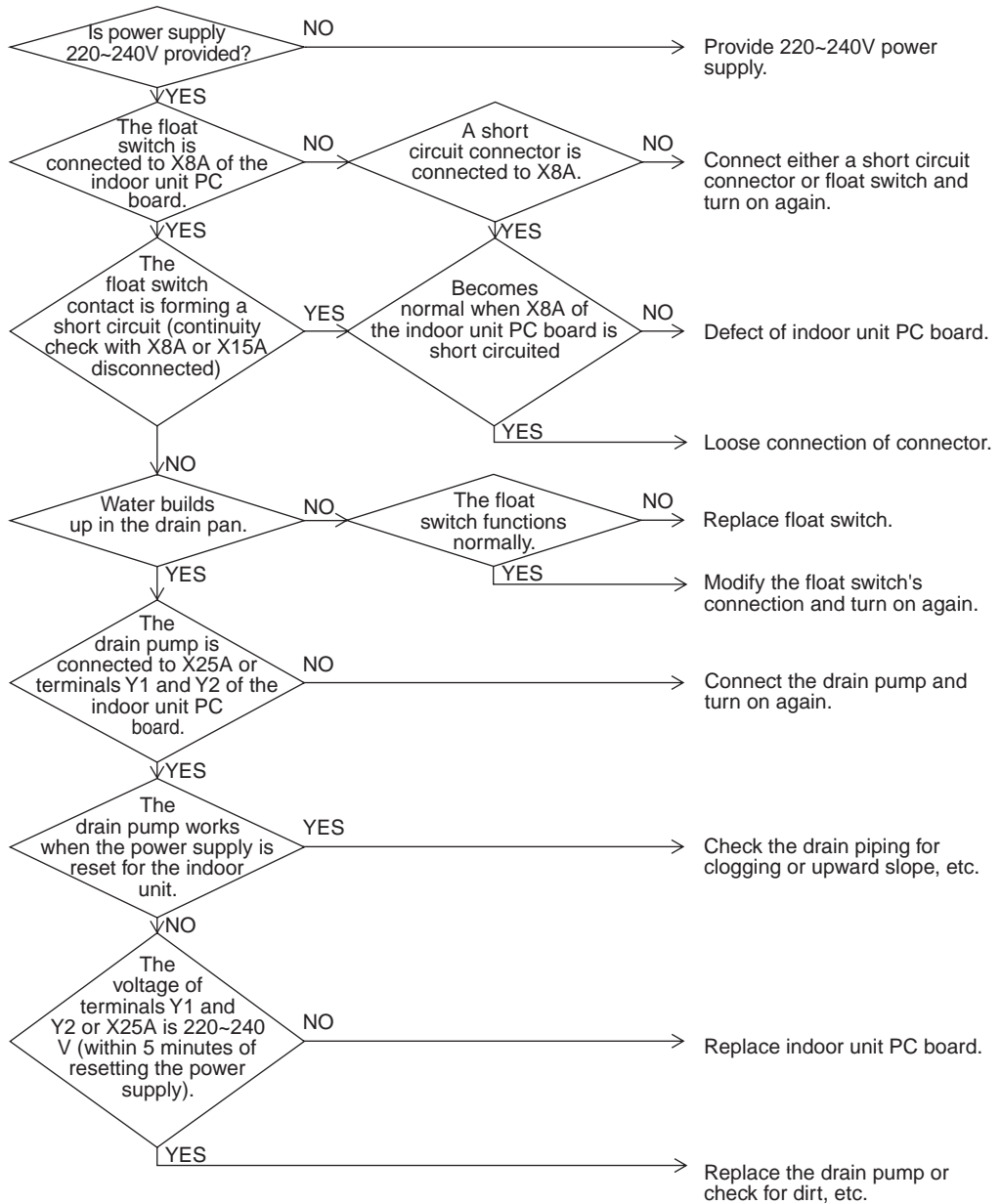

(V2778)

3.4 “R6” Indoor Unit: Fan Motor (M1F) Lock, Overload

Remote Control Display	<i>R6</i>
Applicable Models	FXAQ20~63MAVE, FXFQ25~125MVE
Method of Malfunction Detection	Abnormal fan revolutions are detected by a signal output from the fan motor.
Malfunction Decision Conditions	When the fan revolutions do not increase
Supposed Causes	<ul style="list-style-type: none"> ■ Broken wires in, short circuit of, or disconnection of connectors from the fan motor harness ■ Faulty fan motor (Broken wires or faulty insulation) ■ Abnormal signal output from the fan motor (Faulty circuit) ■ Faulty PC board ■ Instantaneous disturbance in the power supply voltage ■ Fan motor lock (Due to motor or external causes) ■ The fan does not rotate due to foreign matters blocking the fan. ■ Disconnection of the connector between the high-power PC board (A1P) and the low-power PC board (A2P).

Troubleshooting



Caution Be sure to turn off power switch before connect or disconnect connector, or parts damage may be occurred.

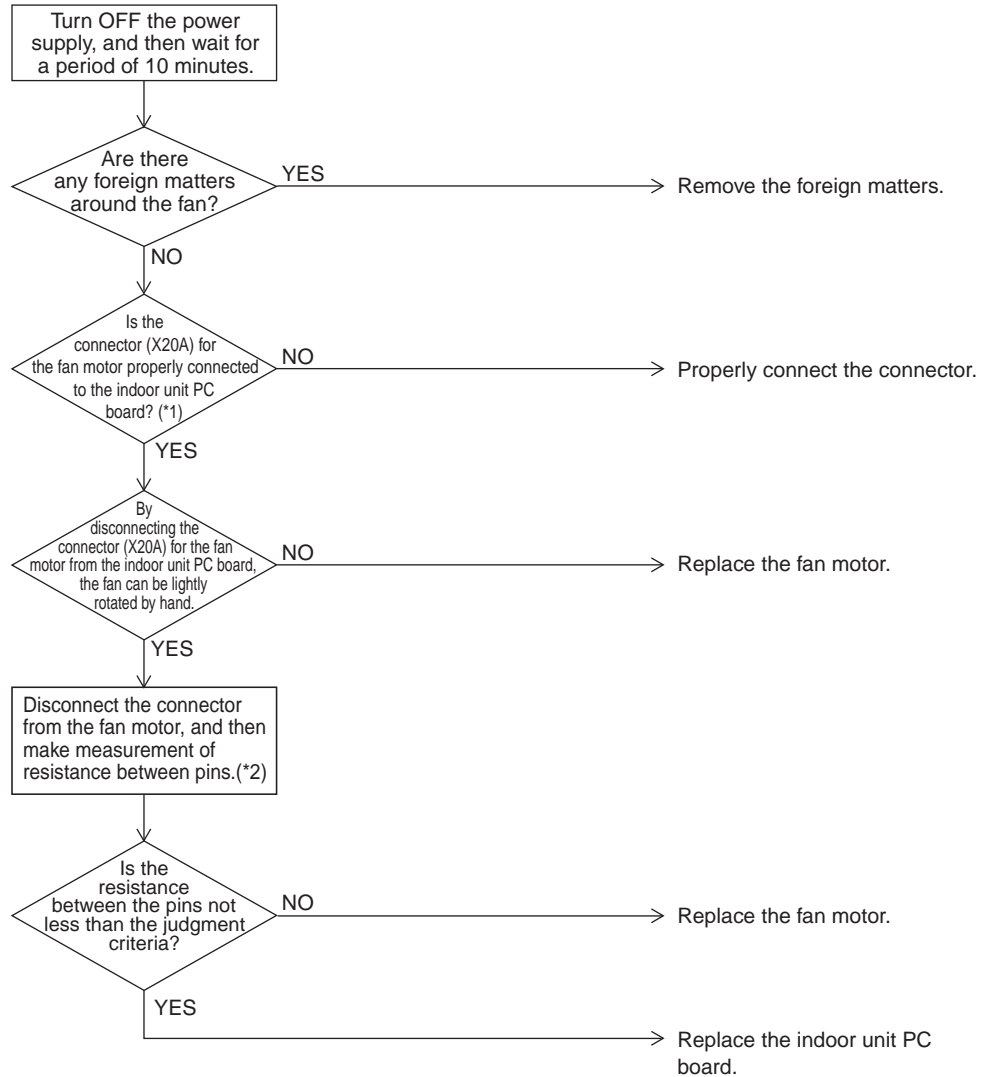

*1. If any junction connector is provided between the connector (X20A) on the indoor unit PC board and the fan motor, also check whether or not the junction connector is properly connected.

*2. All resistance measuring points and judgment criteria

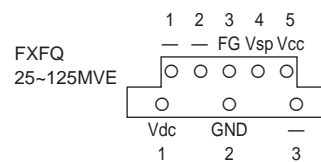
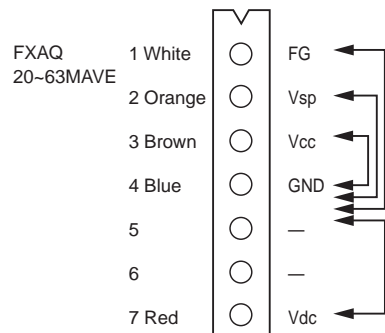

Judgment Criteria

Measuring point	Criteria
FG-GND	Not less than 1MΩ
Vsp-GND	Not less than 100kΩ
Vcc-GND	Not less than 100Ω
Vdc-GND	Not less than 100kΩ

“R6” Indoor Unit: Malfunction of Indoor Unit Fan Motor

Remote Control Display	R6
Applicable Models	FXHQ32~100MAVE, FXDQ20~63NVET, FXDQ20~63NAVE
Method of Malfunction Detection	This malfunction is detected if there is no revolutions detection signal output from the fan motor.
Malfunction Decision Conditions	When no revolutions can be detected even at the maximum output voltage to the fan
Supposed Causes	<ul style="list-style-type: none"> ■ Faulty indoor fan motor ■ Broken wires ■ Faulty contact

Troubleshooting



Caution

Be sure to turn off power switch before connect or disconnect connector, or parts damage may be occurred.

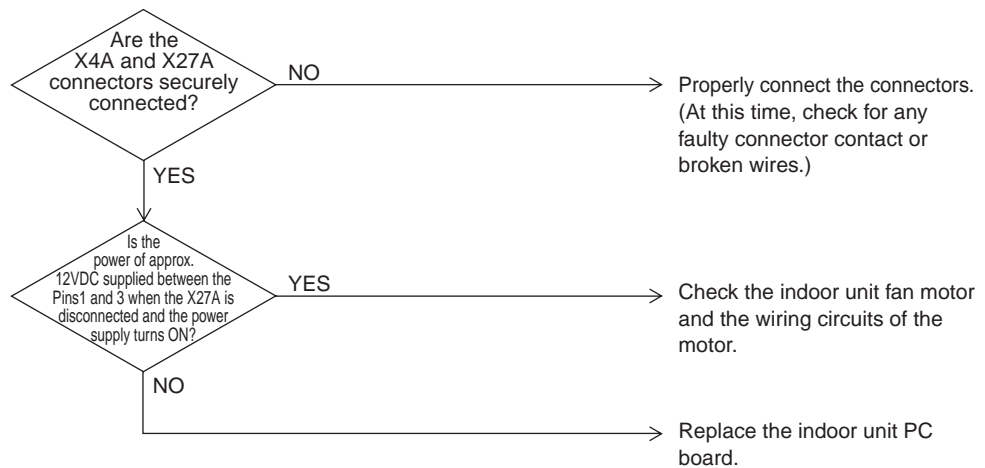

“R6” Indoor Unit: Overload / Overcurrent / Lock of Indoor Unit Fan Motor

Remote Control Display	R6
Applicable Models	FXMQ40~125MAVE
Method of Malfunction Detection	This malfunction is detected by detecting that the individual power supply for the fan turns OFF.
Malfunction Decision Conditions	When it is not detected that the individual power supply for the indoor unit fan turns ON while in operation.
Supposed Causes	<ul style="list-style-type: none"> ■ Faulty power supply for the indoor unit fan motor ■ Clogged drain piping ■ Actuation of the indoor unit safety device ■ Faulty contact in the fan wiring circuit

Troubleshooting



Caution

Be sure to turn off power switch before connect or disconnect connector, or parts damage may be occurred.

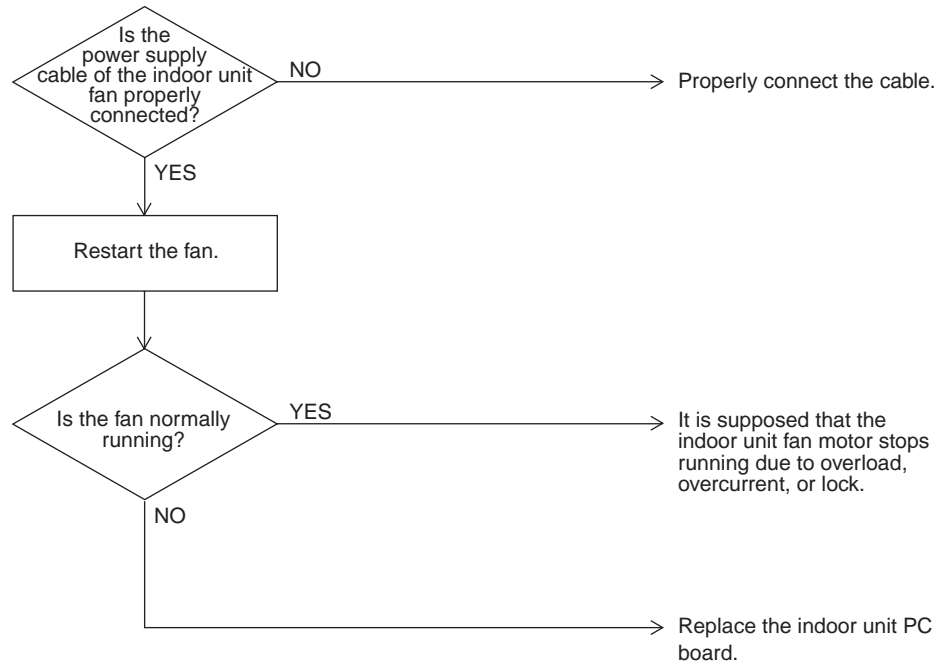

3.5 “A7” Indoor Unit: Malfunction of Swing Flap Motor (M1S)

Remote Control Display	A7
Applicable Models	FXCQ, FXHQ, FXKQ
Method of Malfunction Detection	Utilizes ON/OFF of the limit switch when the motor turns.
Malfunction Decision Conditions	When ON/OFF of the microswitch for positioning cannot be reversed even though the swing flap motor is energized for a specified amount of time (about 30 seconds). ★ Error code is displayed but the system operates continuously.
Supposed Causes	<ul style="list-style-type: none"> ■ Defect of swing motor ■ Defect of connection cable (power supply and limit switch) ■ Defect of air flow direction adjusting flap-cam ■ Defect of indoor unit PC board

Troubleshooting



Caution

Be sure to turn off power switch before connect or disconnect connector, or parts damage may be occurred.

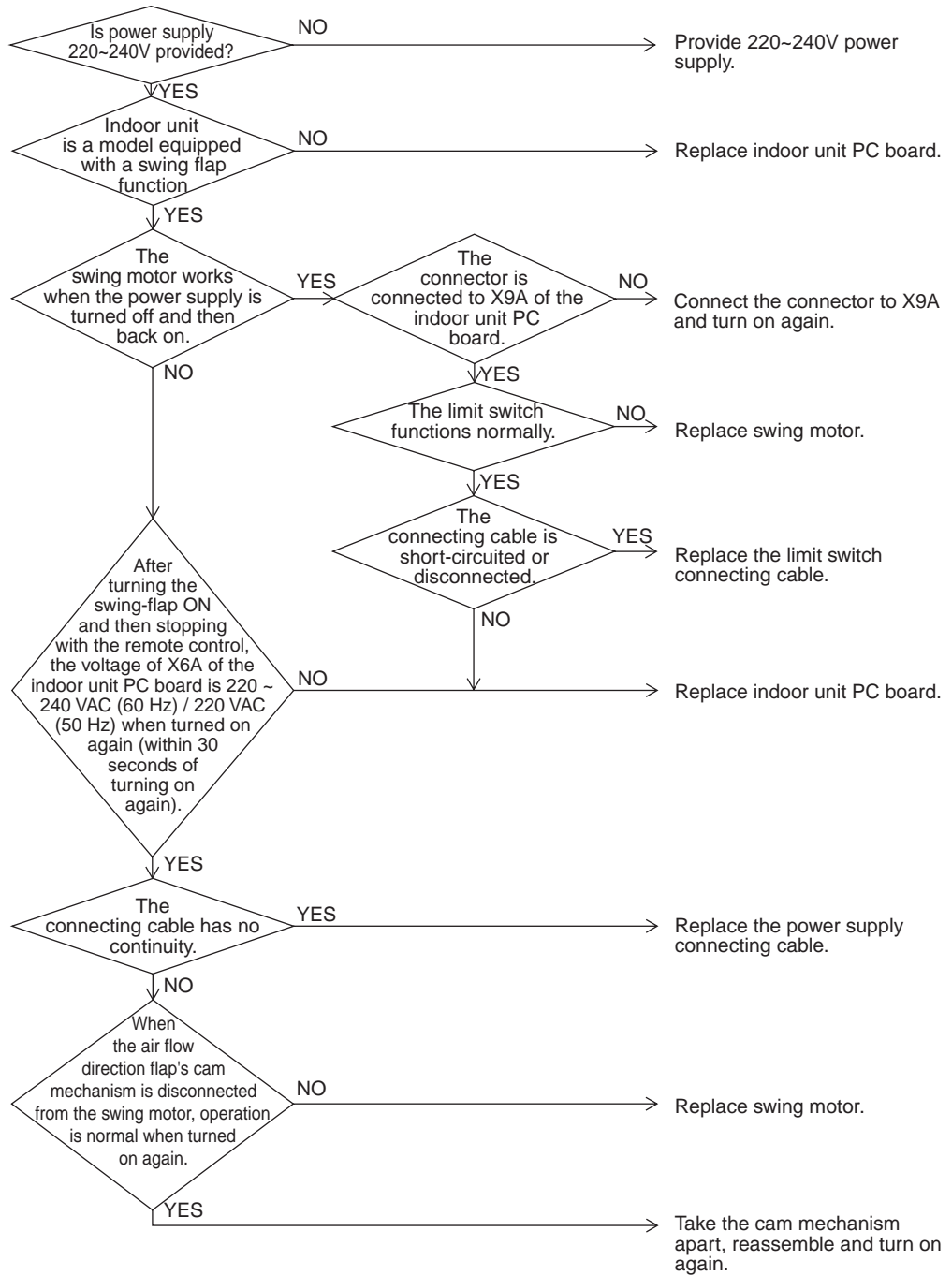

(V2780)

3.6 “R9” Indoor Unit: Electronic Expansion Valve Malfunction / Dust Clogging

Remote Control Display	R9
Applicable Models	FXFQ25~125M
Method of Malfunction Detection	<p>Check coil condition of electronic expansion valve by using microcomputer.</p> <p>Check dust clogging condition of electronic expansion valve main body by using microcomputer.</p>
Malfunction Decision Conditions	<p>Pin input for electronic expansion valve coil is abnormal when initializing microcomputer.</p> <p>Either of the following conditions is seen/caused/ occurs while the unit stops operation.</p> <ul style="list-style-type: none"> ● Temperature of suction air (R1T) – temperature of liquid pipe of heat exchanger (R2T)>8°C. ● Temperature of liquid pipe of heat exchanger (R2T) shows fixed degrees or below.
Supposed Causes	<ul style="list-style-type: none"> ■ Defective drive of electronic expansion valve ■ Defective PC board of indoor unit ■ Defective relay cables

Troubleshooting



Caution

Be sure to turn off power switch before connect or disconnect connector, or parts damage may be occurred.

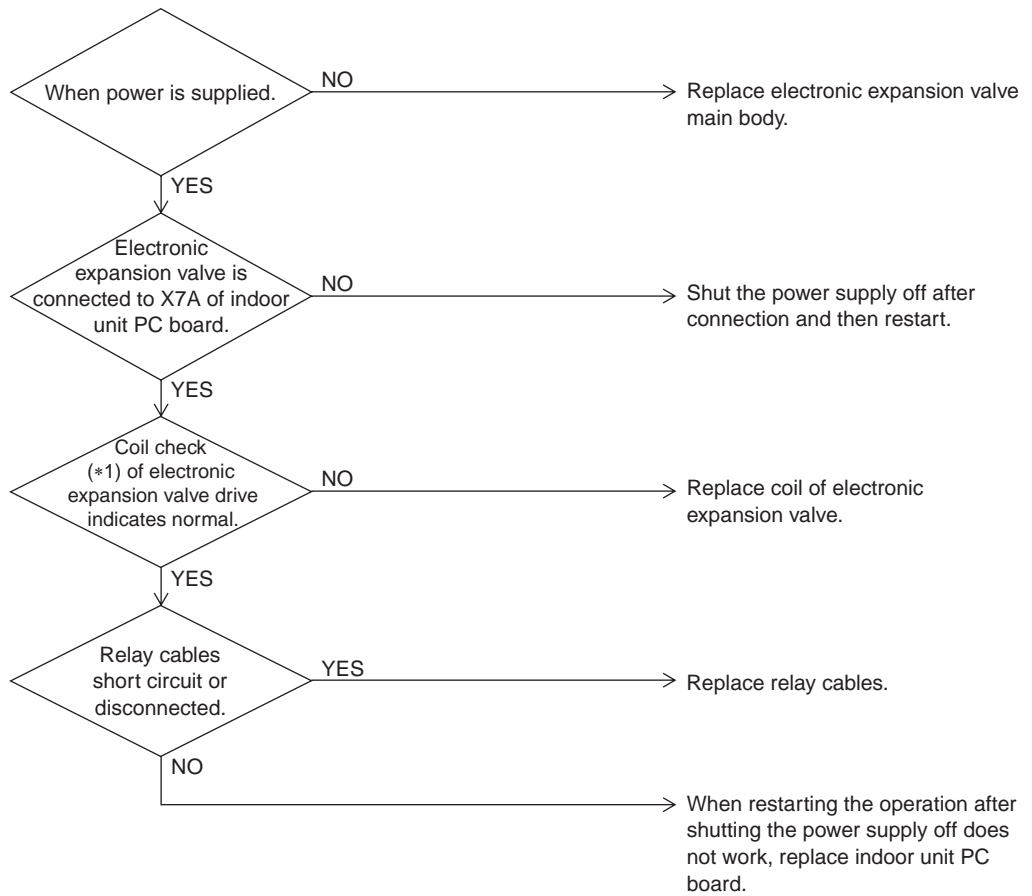

*1: How to check the coil of electronic expansion valve drive

Remove the connector for electronic expansion valve (X7A) from PC board. Measure the resistance value between pins and check the continuity to judge the condition.

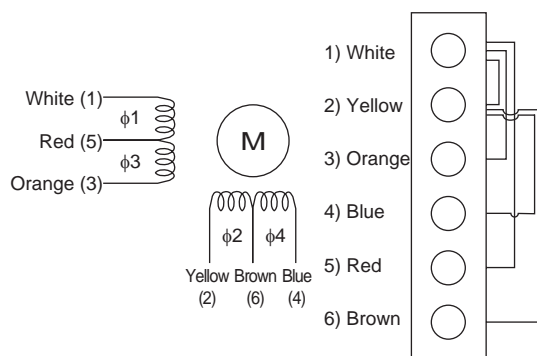

The normal products will show the following conditions:

- ① No continuity between (1) and (2)
- ② Resistance value between (1) and (3) is approx. 300 Ω
- ③ Resistance value between (1) and (5) is approx. 150 Ω
- ④ Resistance value between (2) and (4) is approx. 300 Ω
- ⑤ Resistance value between (2) and (6) is approx. 150 Ω

“A9” Indoor Unit: Malfunction of Electronic Expansion Valve Coil

Remote Control Display	<i>A9</i>
Applicable Models	Indoor units except FXFQ models
Method of Malfunction Detection	Check coil condition of electronic expansion valve by using microcomputer.
Malfunction Decision Conditions	Pin input for electronic expansion valve coil is abnormal when initializing microcomputer.
Supposed Causes	<ul style="list-style-type: none"> ■ Defective drive of electronic expansion valve ■ Defective PC board of indoor unit ■ Defective relay cables

Troubleshooting



Caution Be sure to turn off power switch before connect or disconnect connector, or parts damage may be occurred.

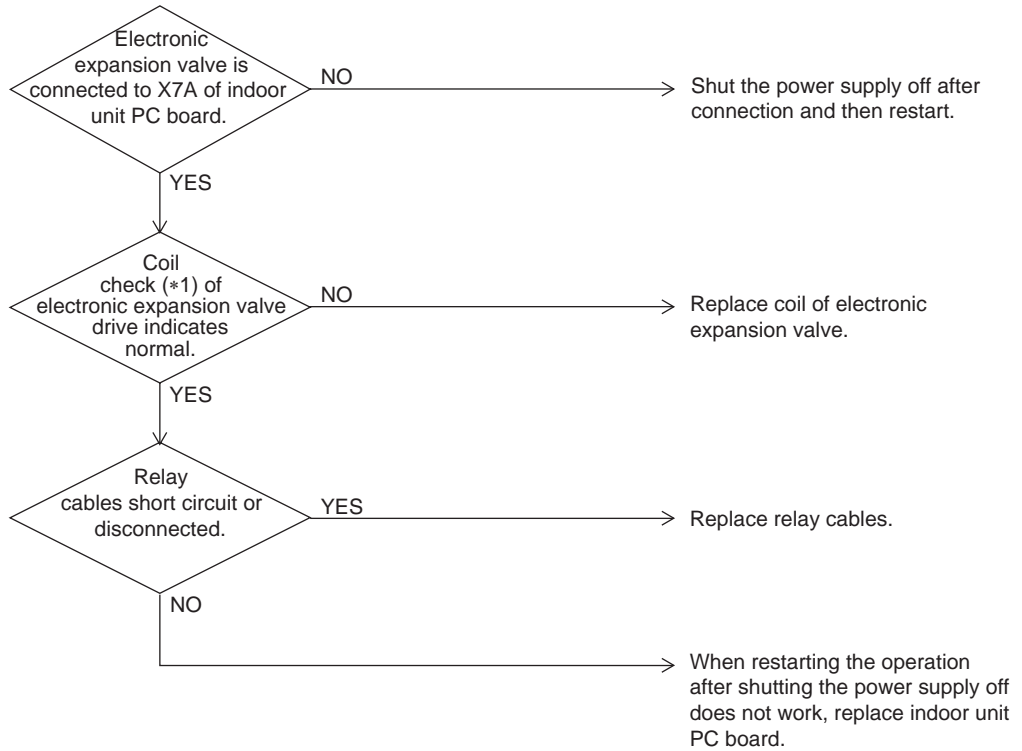

*1: How to check the coil of electronic expansion valve drive

Remove the connector for electronic expansion valve (X7A) from PC board. Measure the resistance value between pins and check the continuity to judge the condition.

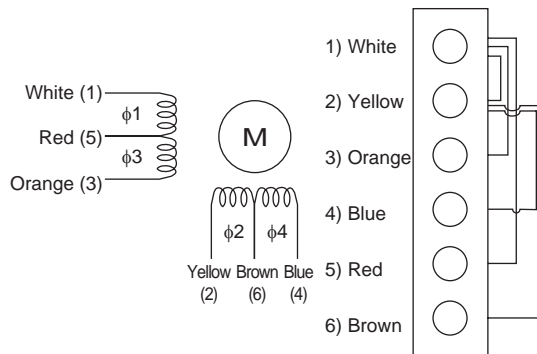

The normal products will show the following conditions:

- ① No continuity between (1) and (2)
- ② Resistance value between (1) and (3) is approx. 300 Ω
- ③ Resistance value between (1) and (5) is approx. 150 Ω
- ④ Resistance value between (2) and (4) is approx. 300 Ω
- ⑤ Resistance value between (2) and (6) is approx. 150 Ω

3.7 “AF” Indoor Unit: Drain Level above Limit

Remote Control Display	<i>AF</i>
Applicable Models	FXCQ, FXFQ, FXSQ, FXKQ, FXMQ, FXDQ, FXMQ-MF
Method of Malfunction Detection	Water leakage is detected based on float switch ON/OFF operation while the compressor is in non-operation.
Malfunction Decision Conditions	When the float switch changes from ON to OFF while the compressor is in non-operation. ★ Error code is displayed but the system operates continuously.
Supposed Causes	<ul style="list-style-type: none"> ■ Humidifier unit (optional accessory) leaking ■ Defect of drain pipe (upward slope, etc.) ■ Defect of indoor unit PC board

Troubleshooting

 **Caution** Be sure to turn off power switch before connect or disconnect connector, or parts damage may be occurred.

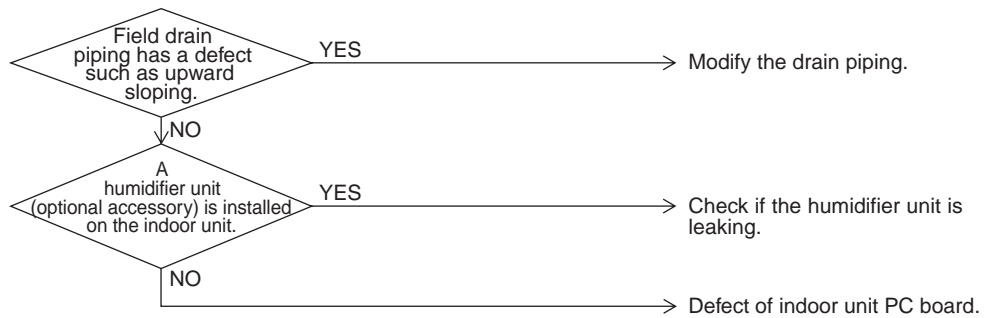

(V2782)

3.8 “AU” Indoor Unit: Malfunction of Capacity Determination Device

Remote Control display	AU
Applicable Models	All indoor unit models
Method of Malfunction Detection	Capacity is determined according to resistance of the capacity setting adapter and the memory inside the IC memory on the indoor unit PC board, and whether the value is normal or abnormal is determined.
Malfunction Decision Conditions	When the capacity code is not contained in the PC board's memory, and the capacity setting adapter is not connected.
Supposed Causes	<ul style="list-style-type: none"> ■ The capacity setting adapter was not installed. ■ Defect of indoor unit PC board

Troubleshooting



Caution

Be sure to turn off power switch before connect or disconnect connector, or parts damage may be occurred.

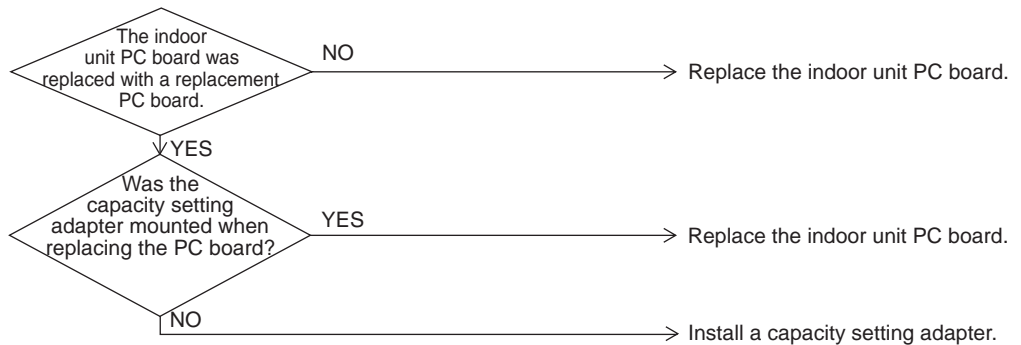

(V2783)

3.9 “E4” Indoor Unit: Malfunction of Thermistor (R2T) for Heat Exchanger

Remote Control Display	E4
Applicable Models	All indoor unit models
Method of Malfunction Detection	Malfunction detection is carried out by temperature detected by heat exchanger thermistor.
Malfunction Decision Conditions	When the heat exchanger thermistor becomes disconnected or shorted while the unit is running.
Supposed Causes	<ul style="list-style-type: none"> ■ Defect of thermistor (R2T) for liquid pipe ■ Defect of indoor unit PC board

Troubleshooting



Caution

Be sure to turn off power switch before connect or disconnect connector, or parts damage may be occurred.

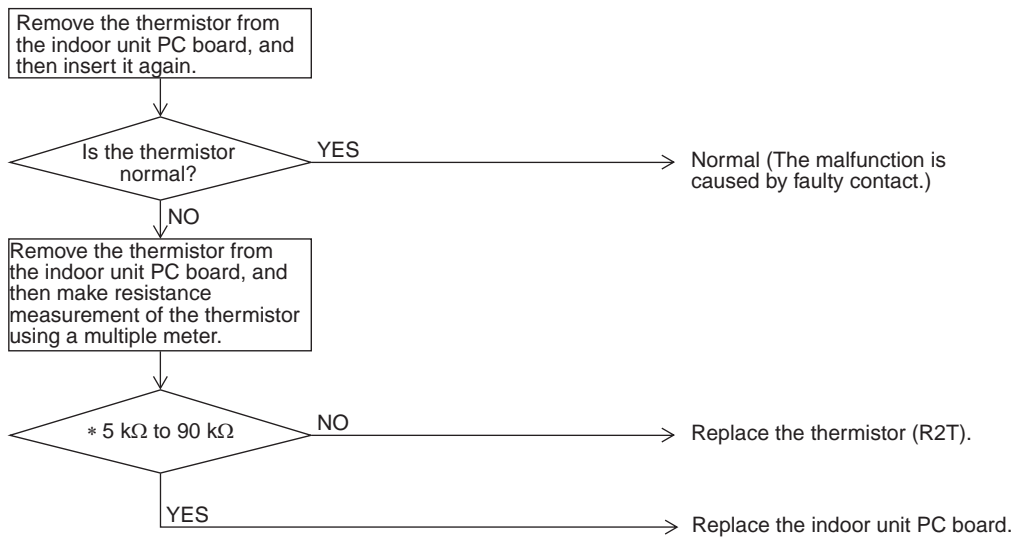

* Refer to “Thermistor Resistance / Temperature Characteristics” table on P417.

3.10 “E5” Indoor Unit: Malfunction of Thermistor (R3T) for Gas Pipes

Remote Control Display

E5

Applicable Models

All indoor unit models

Method of Malfunction Detection

Malfunction detection is carried out by temperature detected by gas pipe thermistor.

Malfunction Decision Conditions

When the gas pipe thermistor becomes disconnected or shorted while the unit is running.

Supposed Causes

- Defect of indoor unit thermistor (R3T) for gas pipe
- Defect of indoor unit PC board

Troubleshooting



Caution

Be sure to turn off power switch before connect or disconnect connector, or parts damage may be occurred.

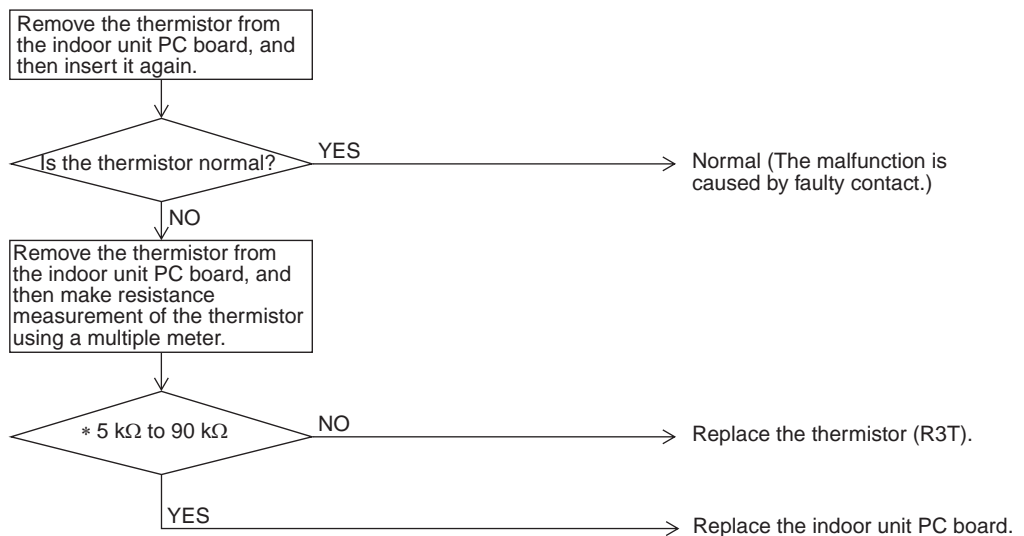

* Refer to “Thermistor Resistance / Temperature Characteristics” table on P417.

3.11 “E9” Indoor Unit: Malfunction of Thermistor (R1T) for Suction Air

Remote Control Display	E9
Applicable Models	All indoor unit models
Method of Malfunction Detection	Malfunction detection is carried out by temperature detected by suction air temperature thermistor.
Malfunction Decision Conditions	When the suction air temperature thermistor becomes disconnected or shorted while the unit is running.
Supposed Causes	<ul style="list-style-type: none"> ■ Defect of indoor unit thermistor (R1T) for air inlet ■ Defect of indoor unit PC board

Troubleshooting

 **Caution** Be sure to turn off power switch before connect or disconnect connector, or parts damage may be occurred.

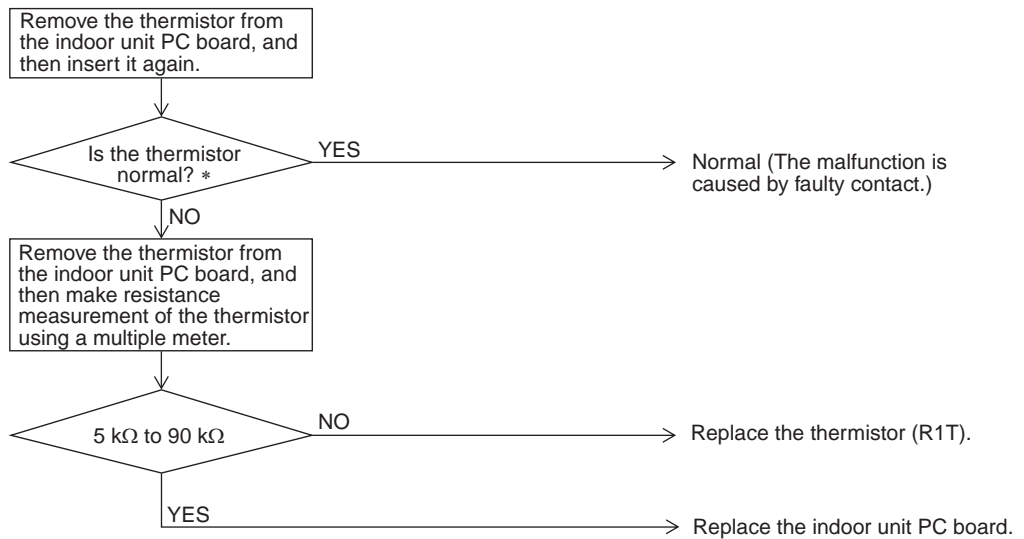

* Refer to “Thermistor Resistance / Temperature Characteristics” table on P417.

3.12 “EJ” Indoor Unit: Malfunction of Thermostat Sensor in Remote Control

Remote Control Display	EJ
Applicable Models	All indoor unit models
Method of Malfunction Detection	Malfunction detection is carried out by temperature detected by remote control air temperature thermistor. (Note:)
Malfunction Decision Conditions	When the remote control air temperature thermistor becomes disconnected or shorted while the unit is running.
Supposed Causes	<ul style="list-style-type: none"> ■ Defect of remote control thermistor ■ Defect of remote control PC board

Troubleshooting

 **Caution** Be sure to turn off power switch before connect or disconnect connector, or parts damage may be occurred.

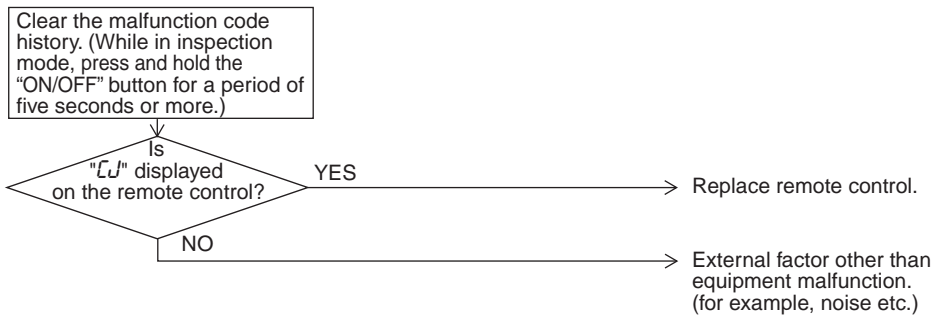

(V2787)

 **Note:** *1: How to delete “the record of malfunction codes”. Press the “Operate/ Stop” button for 4 seconds and more while the malfunction code is displayed in the inspection mode.

 * Refer to “Thermistor Resistance / Temperature Characteristics” table on P417.

3.13 “E1” Outdoor Unit: PC Board Defect

Remote Control Display	E1
Applicable Models	REYQ8P~48P
Method of Malfunction Detection	Abnormality is detected under the communication conditions in the hardware section between the indoor unit and outdoor unit.
Malfunction Decision Conditions	When the communication conditions in the hardware section between the indoor unit and the outdoor unit are not normal.
Supposed Causes	<ul style="list-style-type: none"> ■ Defect of outdoor unit PC board (A1P) ■ Defective connection of inside/ outside relay wires

Troubleshooting

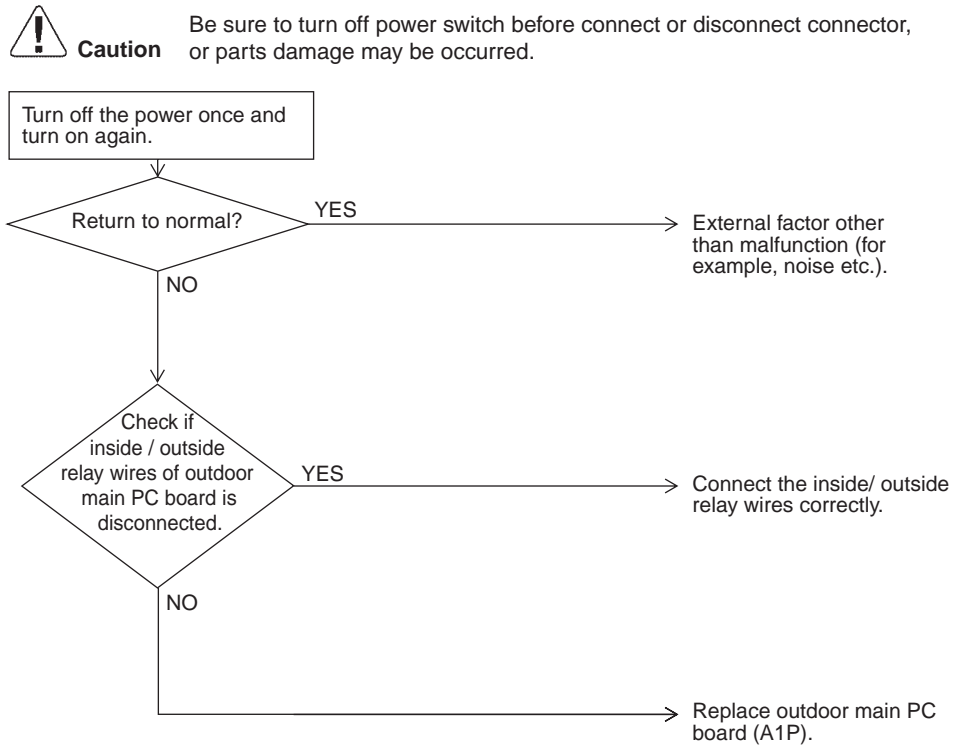

(V3064)

3.14 “E3” Outdoor Unit: Actuation of High Pressure Switch

Remote Control Display	<i>E3</i>
Applicable Models	REYQ8P~48P
Method of Malfunction Detection	Abnormality is detected when the contact of the high pressure protection switch opens.
Malfunction Decision Conditions	Error is generated when the HPS activation count reaches the number specific to the operation mode. (Reference) Operating pressure of high pressure switch Operating pressure: 4.0MPa Reset pressure: 2.85MPa
Supposed Causes	<ul style="list-style-type: none">■ Actuation of outdoor unit high pressure switch■ Defect of High pressure switch■ Defect of outdoor unit main PC board (A1P)■ Instantaneous power failure■ Faulty high pressure sensor

Troubleshooting

 **Caution** Be sure to turn off power switch before connect or disconnect connector, or parts damage may be occurred.

Check for the points shown below.
 ① Is the stop valve open?
 ② Is the HPS connector properly connected to the main PC board?
 ③ Does the high pressure switch have continuity?



① Mount a pressure gauge on the high-pressure service port.
 ② Reset the operation using the remote control, and then restart the operation.

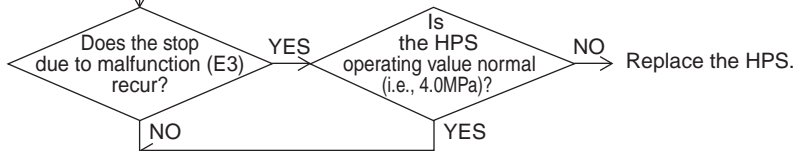

Service Checker
 Connect the service checker to compare the "high pressure" value and the actual measurement value by pressure sensor (Refer to *1) by using the service checker.



· The high pressure sensor is normal, and the pressure detected with the PC board is also normal.
 · The high pressure has really become high.

CHECK 5 Referring to information on P350, remove the causes by which the high pressure has become high.

- *1: Make a comparison between the voltage of the pressure sensor and that read by the pressure gauge.
 (As to the voltage of the pressure sensor, make measurement of voltage at the connector, and then convert it to pressure according to information on P419.)
- *2: Make measurement of voltage of the pressure sensor.

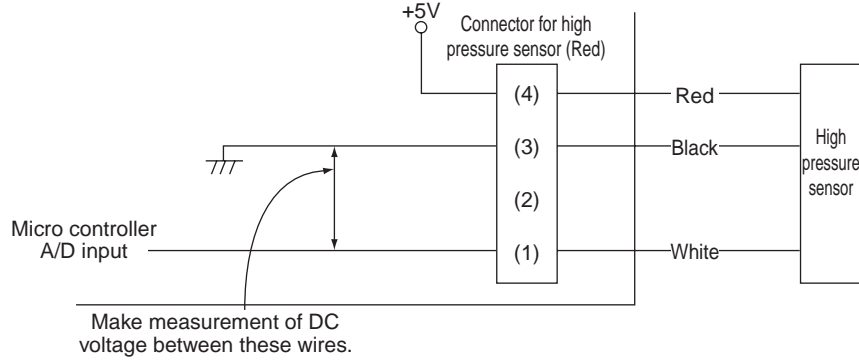

3.15 “E4” Outdoor Unit: Actuation of Low Pressure Sensor

Remote Control Display	<i>E4</i>
Applicable Models	REYQ8P~48P
Method of Malfunction Detection	Abnormality is detected by the pressure value with the low pressure sensor.
Malfunction Decision Conditions	Error is generated when the low pressure is dropped under compressor operation. Operating pressure:0.07MPa
Supposed Causes	<ul style="list-style-type: none">■ Abnormal drop of low pressure (Lower than 0.07MPa)■ Defect of low pressure sensor■ Defect of outdoor unit PC board■ Stop valve is not opened.

Troubleshooting



Caution Be sure to turn off power switch before connect or disconnect connector, or parts damage may be occurred.

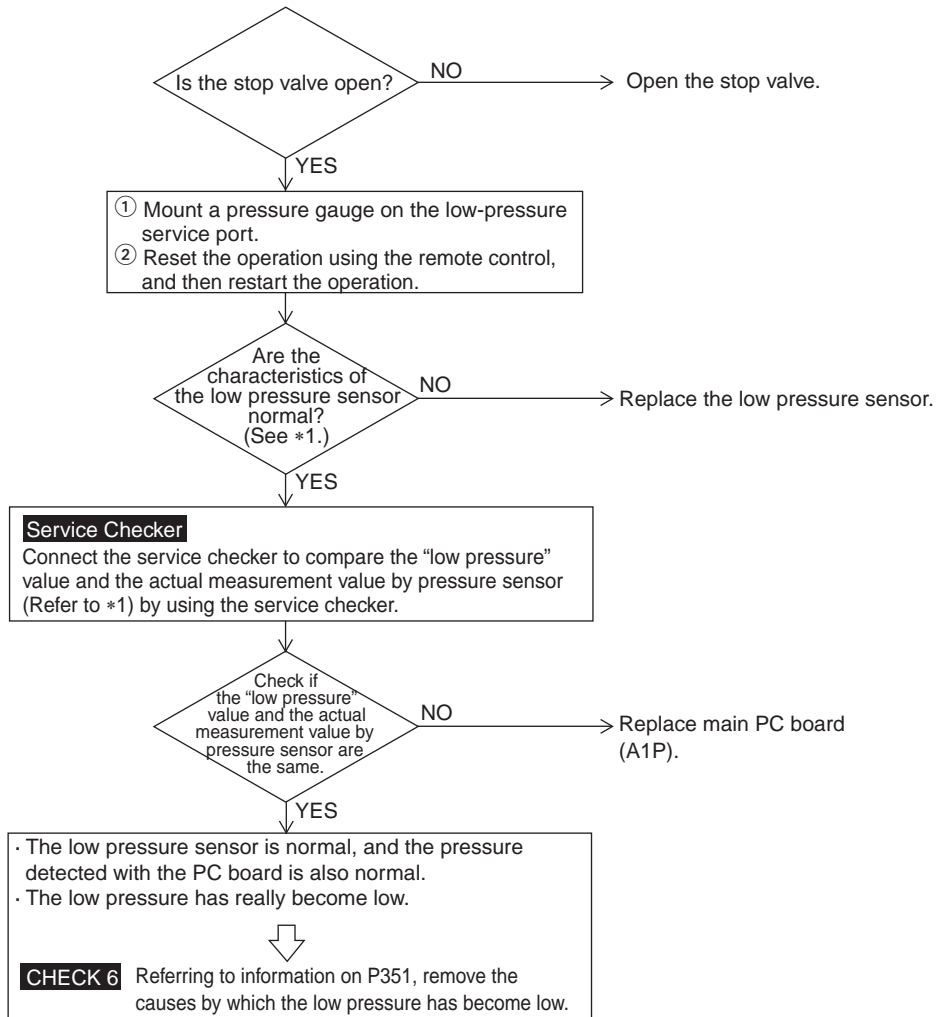

*1: Make a comparison between the voltage of the pressure sensor and that read by the pressure gauge.

(As to the voltage of the pressure sensor, make measurement of voltage at the connector, and then convert it to pressure according to information on P419.)

*2: Make measurement of voltage of the pressure sensor.

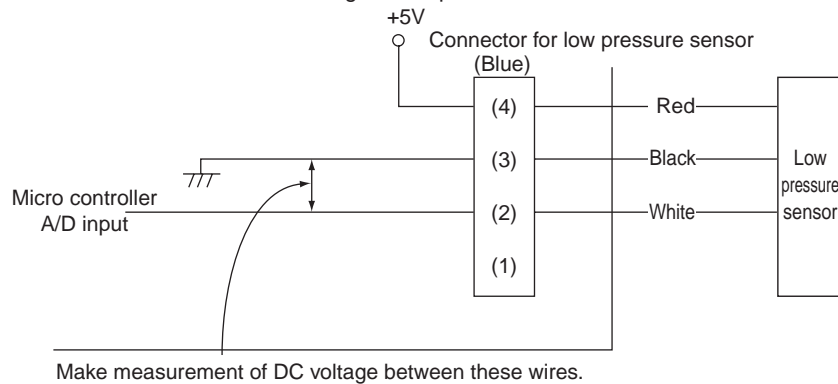

3.16 “E5” Outdoor Unit: Inverter Compressor Motor Lock

Remote Control Display	<i>E5</i>
Applicable Models	REYQ8P~48P
Method of Malfunction Detection	Inverter PC board takes the position signal from UVW line connected between the inverter and compressor, and the malfunction is detected when any abnormality is observed in the phase-current waveform.
Malfunction Decision Conditions	This malfunction will be output when the inverter compressor motor does not start up even in forced startup mode.
Supposed Causes	<ul style="list-style-type: none">■ Inverter compressor lock■ High differential pressure (0.5MPa or more)■ Incorrect UVW wiring■ Faulty inverter PC board■ Stop valve is left in closed.

Troubleshooting



Caution Be sure to turn off power switch before connect or disconnect connector, or parts damage may be occurred.

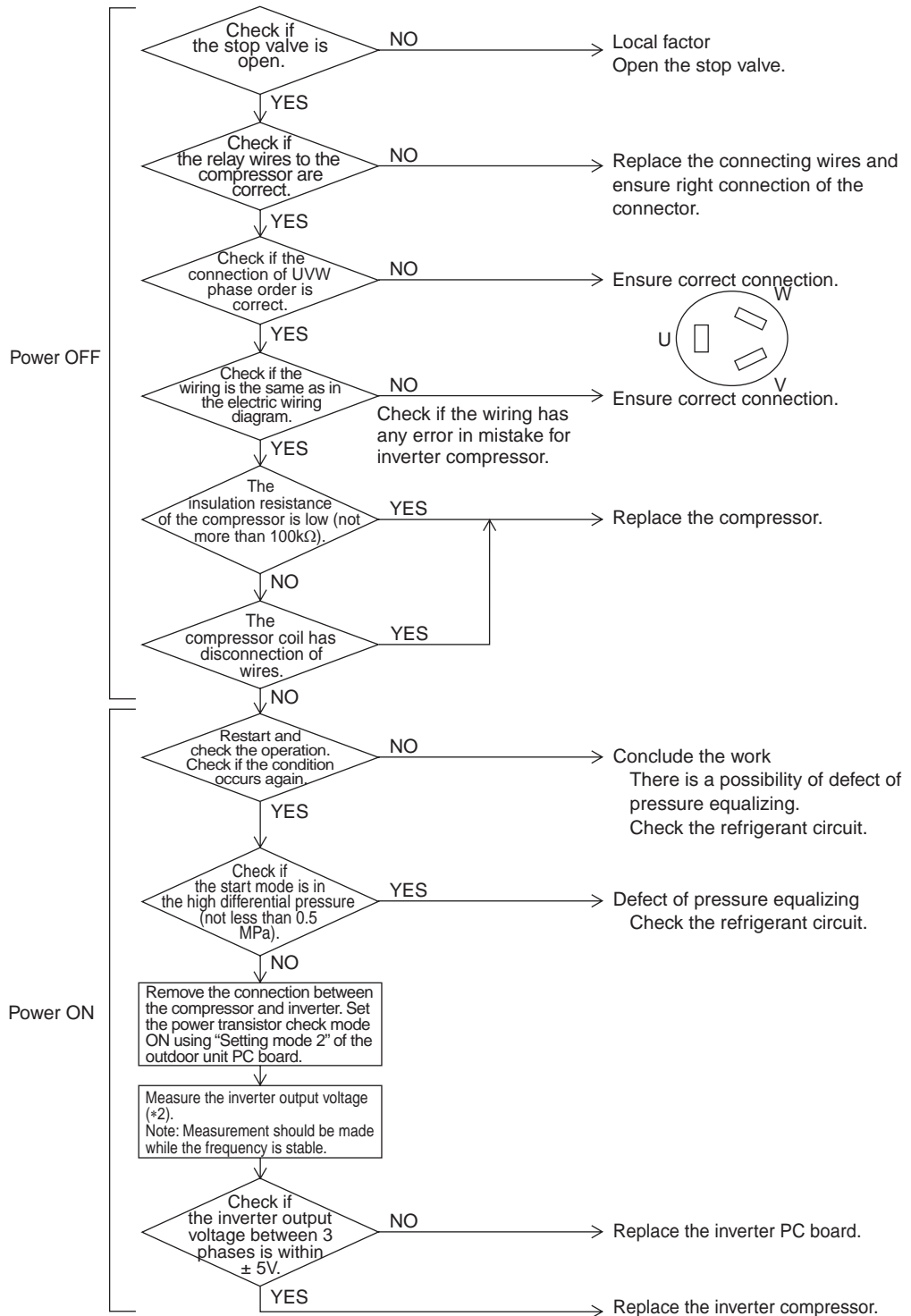

*1: Pressure difference between high pressure and low pressure before starting.

*2: The quality of power transistors/ diode modules can be judged by executing **Check 4** (P349).

3.17 “E6” Outdoor Unit: STD Compressor Motor Overcurrent/ Lock

Remote Control Display	E6
Applicable Models	REYQ8P~48P
Method of Malfunction Detection	Detects the overcurrent with current sensor (CT).
Malfunction Decision Conditions	Malfunction is decided when the detected current value exceeds the below mentioned value for 2 seconds. <ul style="list-style-type: none"> ■ 400 V unit : 15.0 A
Supposed Causes	<ul style="list-style-type: none"> ■ Closed stop valve ■ Obstacles at the air outlet ■ Improper power voltage ■ Faulty magnetic switch ■ Faulty compressor ■ Faulty current sensor (A6P, A7P)

Troubleshooting

 **Caution** Be sure to turn off power switch before connect or disconnect connector, or parts damage may be occurred.

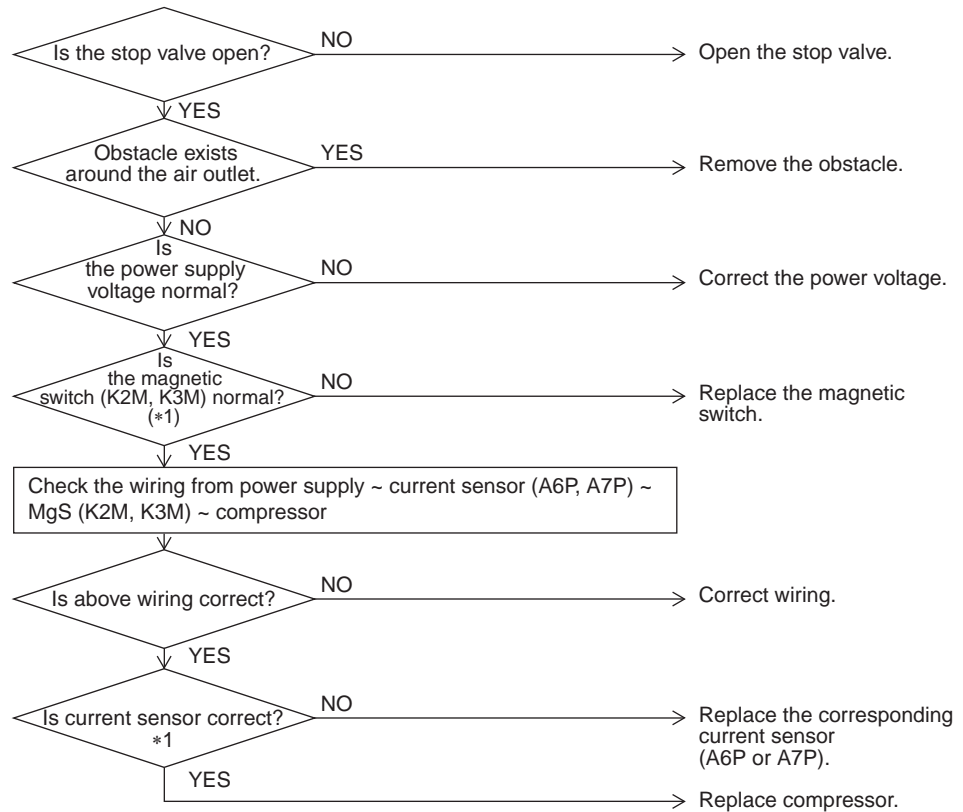

(V3051)



Note:

- *1 One of the possible factors may be chattering due to rough MgS contact.
- *2 Abnormal case
 - The current sensor value is 0 during STD compressor operation.
 - The current sensor value is more than 15.0A during STD compressor stop.

3.18 “E7” Outdoor Unit: Malfunction of Outdoor Unit Fan Motor

Remote Control Display	E7
Applicable Models	REYQ8P~48P
Method of Malfunction Detection	<p>Detect a malfunction based on the current value in the INVERTER PC board (as for motor 2, current value in the fan PC board).</p> <p>Detect a malfunction for the fan motor circuit based on the number of rotation detected by hole IC during the fan motor operation.</p>
Malfunction Decision Conditions	<ul style="list-style-type: none"> ■ Overcurrent is detected for INVERTER PC board (A2P) or fan INVERTER PC board (A5P) (System down is caused by 4 times of detection.) ■ In the condition of fan motor rotation, the number of rotation is below the fixed number for more than 6 seconds. (System down is caused by 4 times of detection.)
Supposed Causes	<ul style="list-style-type: none"> ■ Failure of fan motor ■ Defect or connect ion error of the connectors/ harness between the fan motor and PC board ■ The fan can not rotate due to any foreign substances entangled. ■ Clear condition: Continue normal operation for 5 minutes

Troubleshooting

 **Caution** Be sure to turn off power switch before connect or disconnect connector, or parts damage may be occurred.

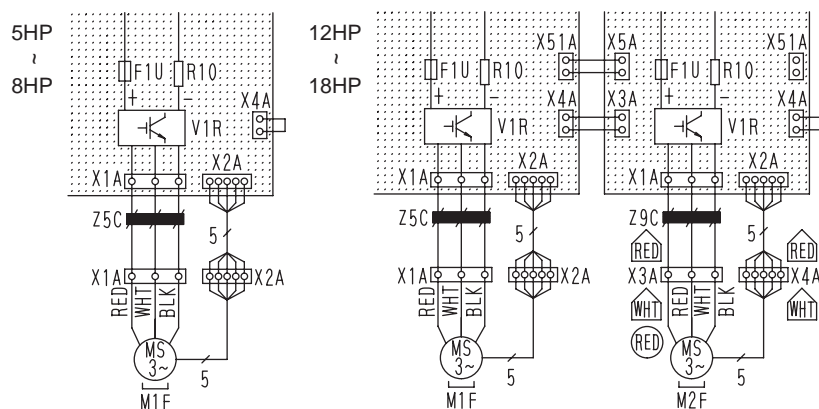
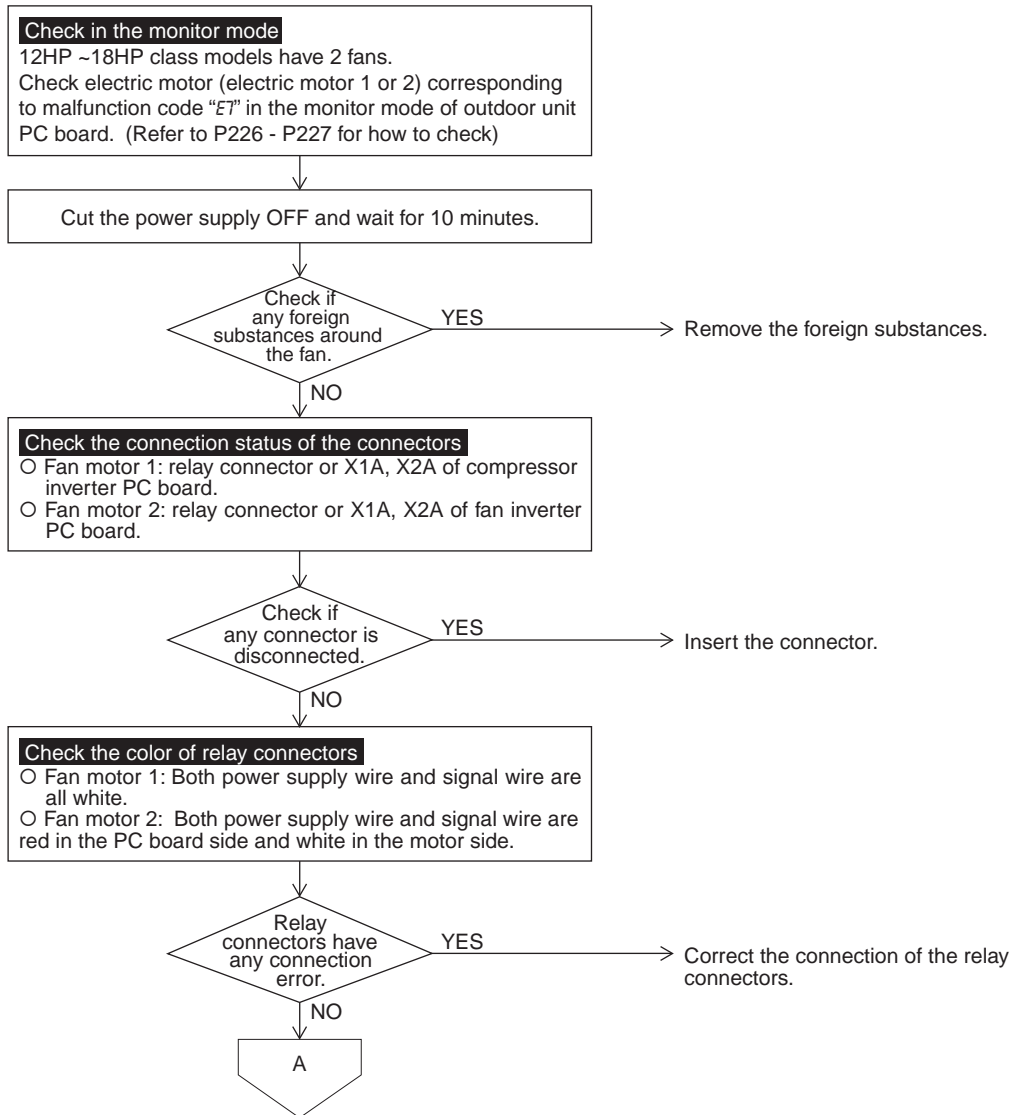

Troubleshooting

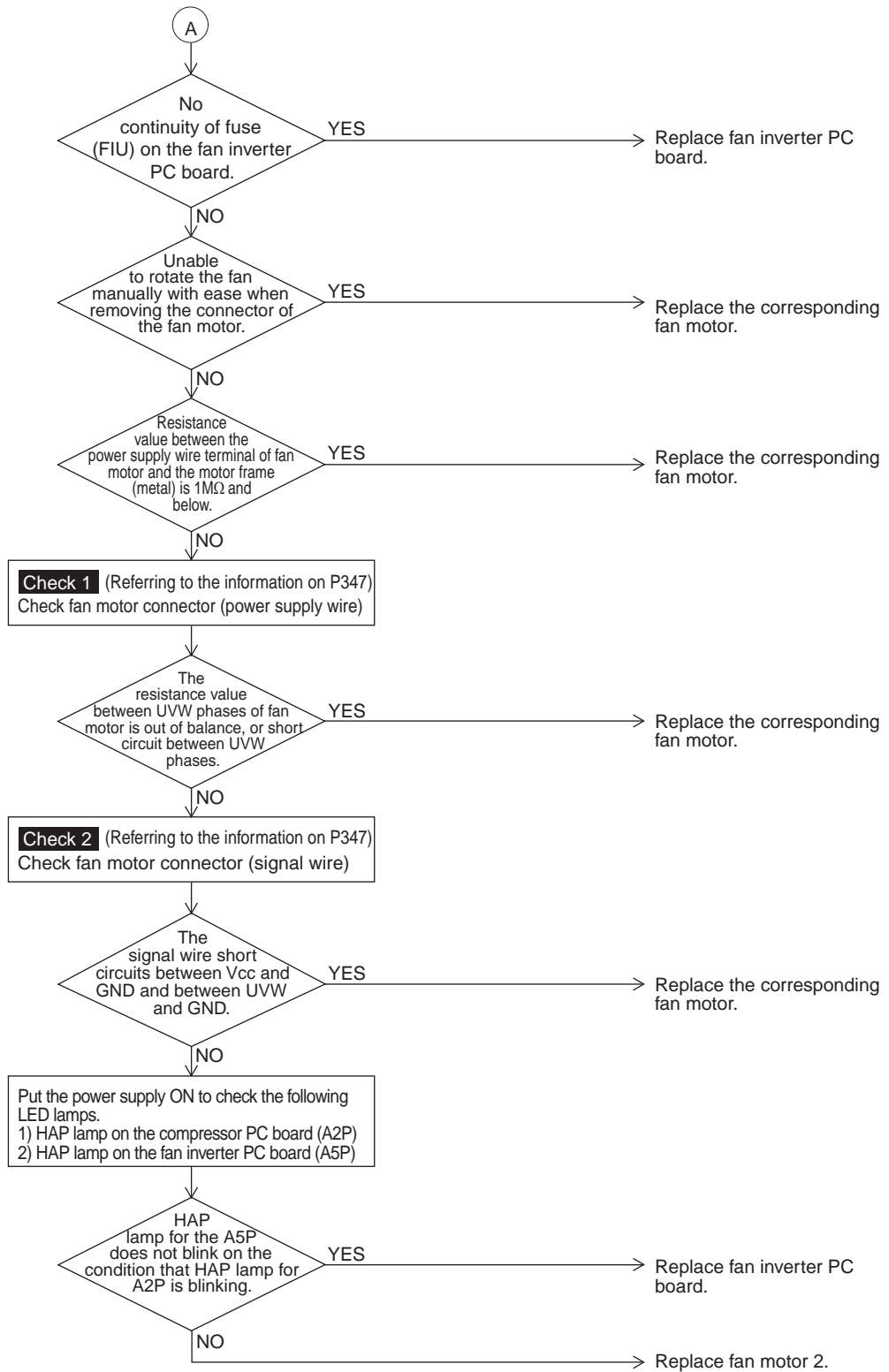

3.19 “E9” Outdoor Unit: Malfunction of Moving Part of Electronic Expansion Valve (Y1E~Y5E)

Remote Control Display	E9
Applicable Models	REYQ8P~48P
Method of Malfunction Detection	Check disconnection of connector To be detected based on continuity existence of coil of electronic expansion valve
Malfunction Decision Conditions	No current is detected in the common (COM [+]) when power supply is ON.
Supposed Causes	<ul style="list-style-type: none"> ■ Disconnection of connectors for electronic expansion valve (Y1E) ■ Defect of moving part of electronic expansion valve ■ Defect of outdoor unit main PC board (A1P)

Troubleshooting



Caution Be sure to turn off power switch before connect or disconnect connector, or parts damage may be occurred.

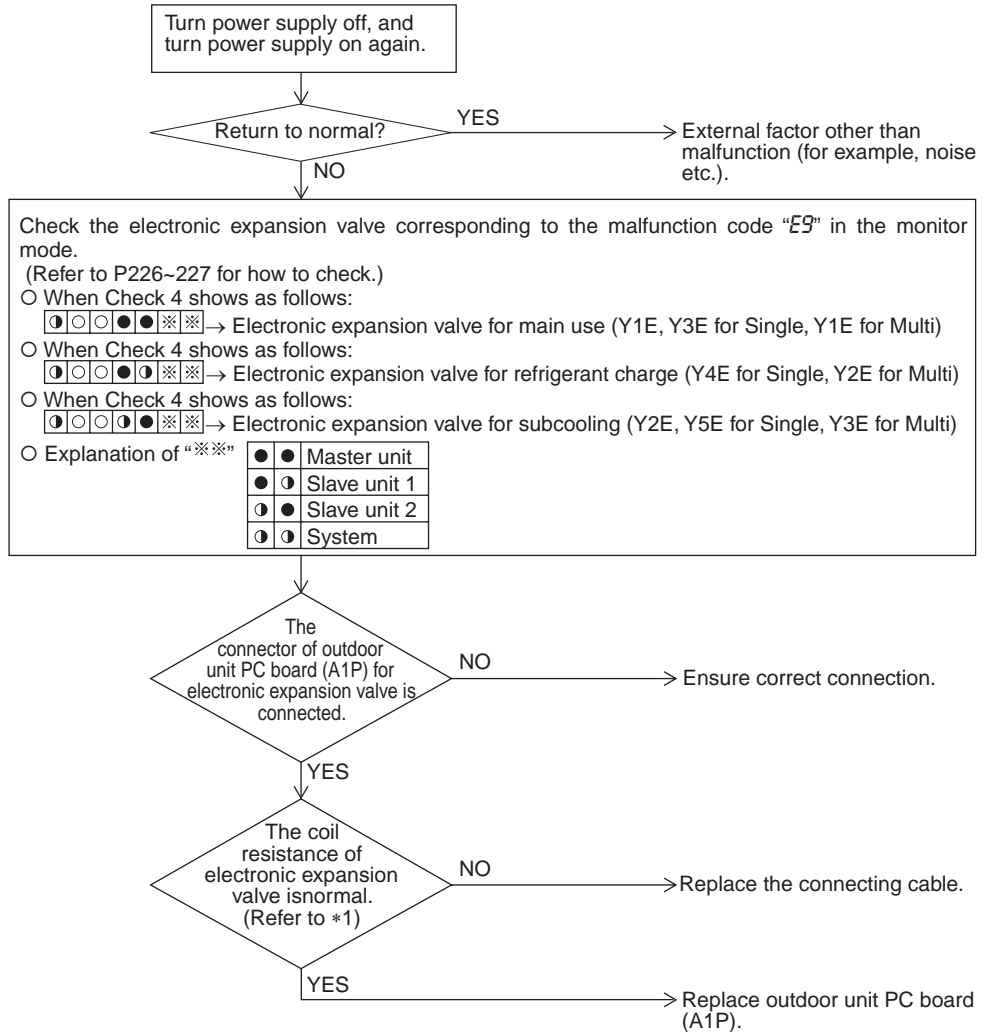

(V3067)

* Make measurement of resistance between the connector pins, and then make sure the resistance falls in the range of 40 to 50Ω.

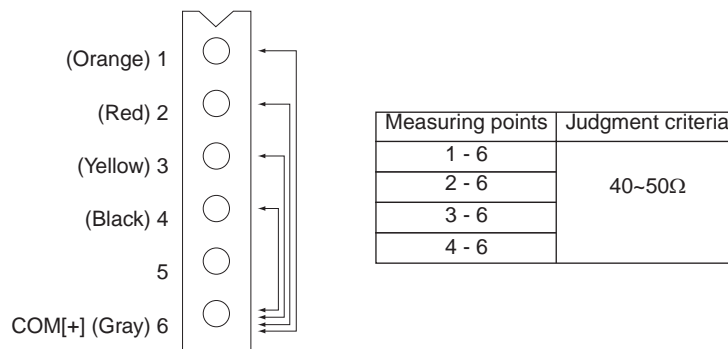

(V3067)

3.20 “F3” Outdoor Unit: Abnormal Discharge Pipe Temperature

Remote Control Display **F3**

Applicable Models REYQ8P~48P

Method of Malfunction Detection Abnormality is detected according to the temperature detected by the discharge pipe temperature sensor.

Malfunction Decision Conditions
 When the discharge pipe temperature rises to an abnormally high level (135 °C and above)
 When the discharge pipe temperature rises suddenly (120 °C and above for 10 successive minutes)

Supposed Causes

- Faulty discharge pipe temperature sensor
- Faulty connection of discharge pipe temperature sensor
- Faulty outdoor unit PC board

Troubleshooting



Caution Be sure to turn off power switch before connect or disconnect connector, or parts damage may be occurred.

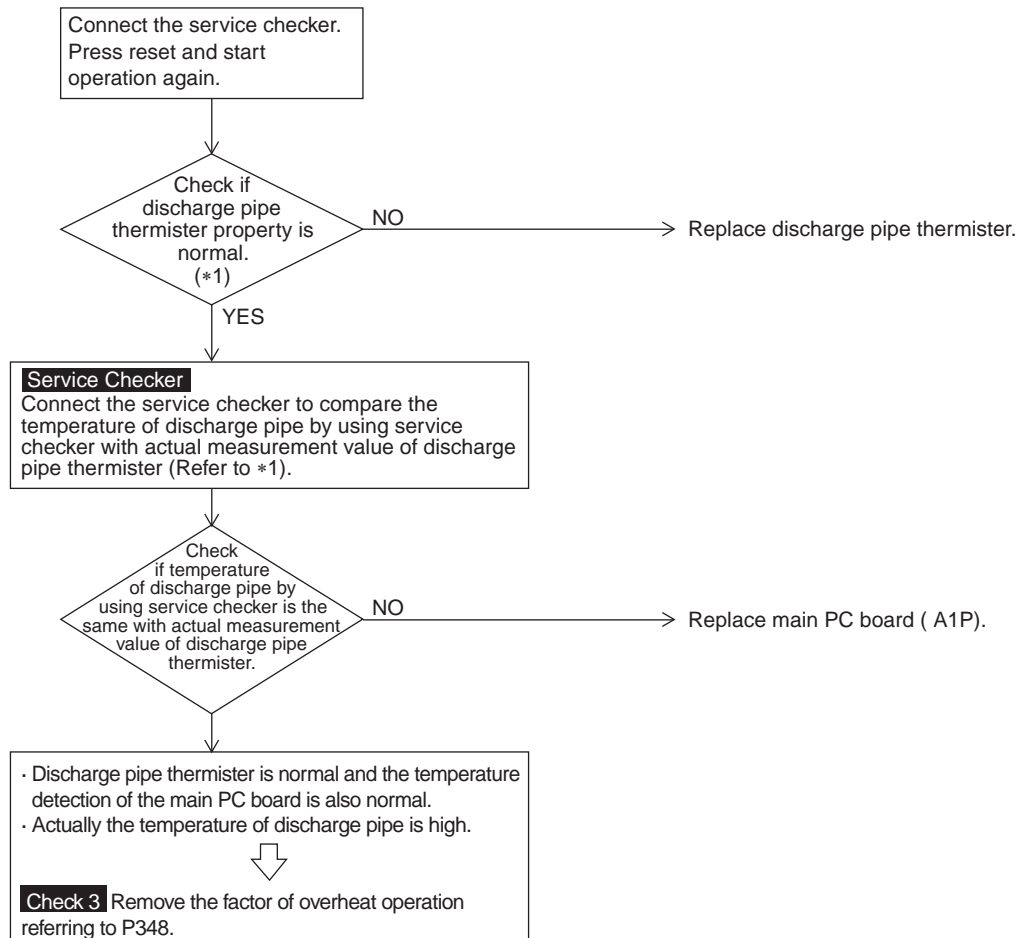

*1: Compare the resistance value of discharge pipe thermister and the value based on the surface thermometer.
(Refer to P417 for the temperature of thermister and the resistance property)



* Refer to “Thermistor Resistance / Temperature Characteristics” table on P417.

3.21 “F6” Outdoor Unit: Refrigerant Overcharged

Remote Control Display	F6
Applicable Models	REYQ8P~48P
Method of Malfunction Detection	Excessive charging of refrigerant is detected by using the outside air temperature, heat exchanging deicer temperature and liquid pipe temperature during a check run.
Malfunction Decision Conditions	When the amount of refrigerant, which is calculated by using the outside air temperature, heat exchanging deicer temperature and liquid pipe temperature during a check run, exceeds the standard.
Supposed Causes	<ul style="list-style-type: none"> ■ Refrigerant overcharge ■ Misalignment of the outside air thermistor ■ Misalignment of the heat exchanging deicer thermistor ■ Misalignment of the liquid pipe thermistor

Troubleshooting

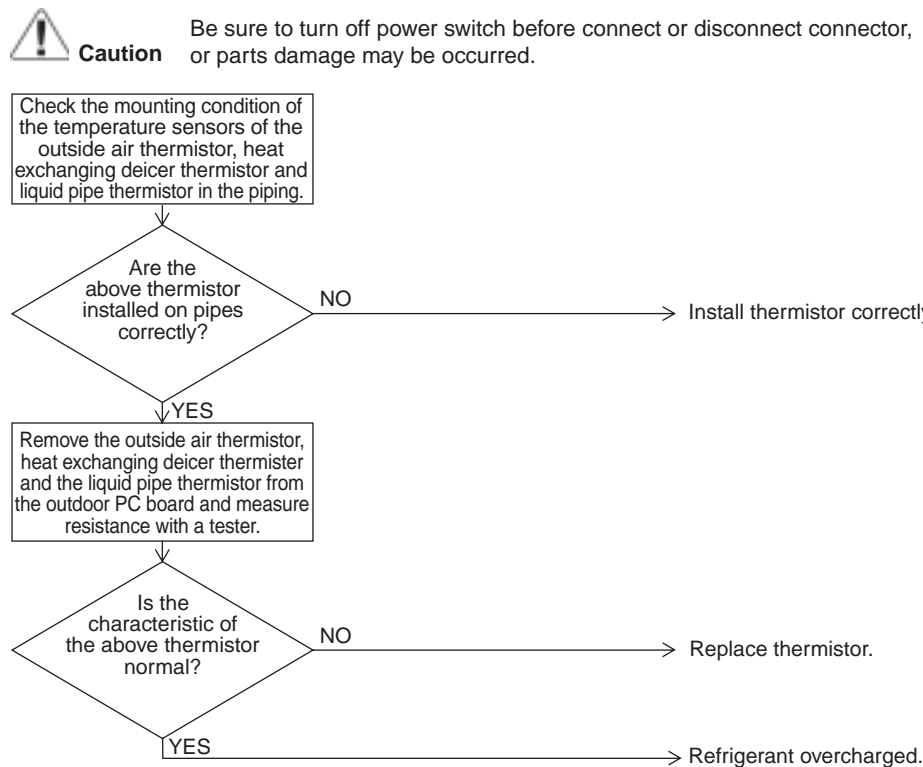

(V2797)



* Refer to “Thermistor Resistance / Temperature Characteristics” table on P417.

3.22 “F9” Outdoor Unit: Malfunction of BS Unit Electronic Expansion Valve

Remote Control Display	<i>F9</i>
Applicable Models	BS unit
Method of Malfunction Detection	This malfunction is detected by whether or not all coils of the electronic expansion valve have continuity.
Malfunction Decision Conditions	When the power supply turns ON, there is no currents pass through the common (COM[+]).
Supposed Causes	<ul style="list-style-type: none">■ Connector disconnected from the electronic expansion valve■ Faulty coil of the electronic expansion valve■ Faulty PC board of the BS unit

Troubleshooting



Caution

Be sure to turn off power switch before connect or disconnect connector, or parts damage may be occurred.

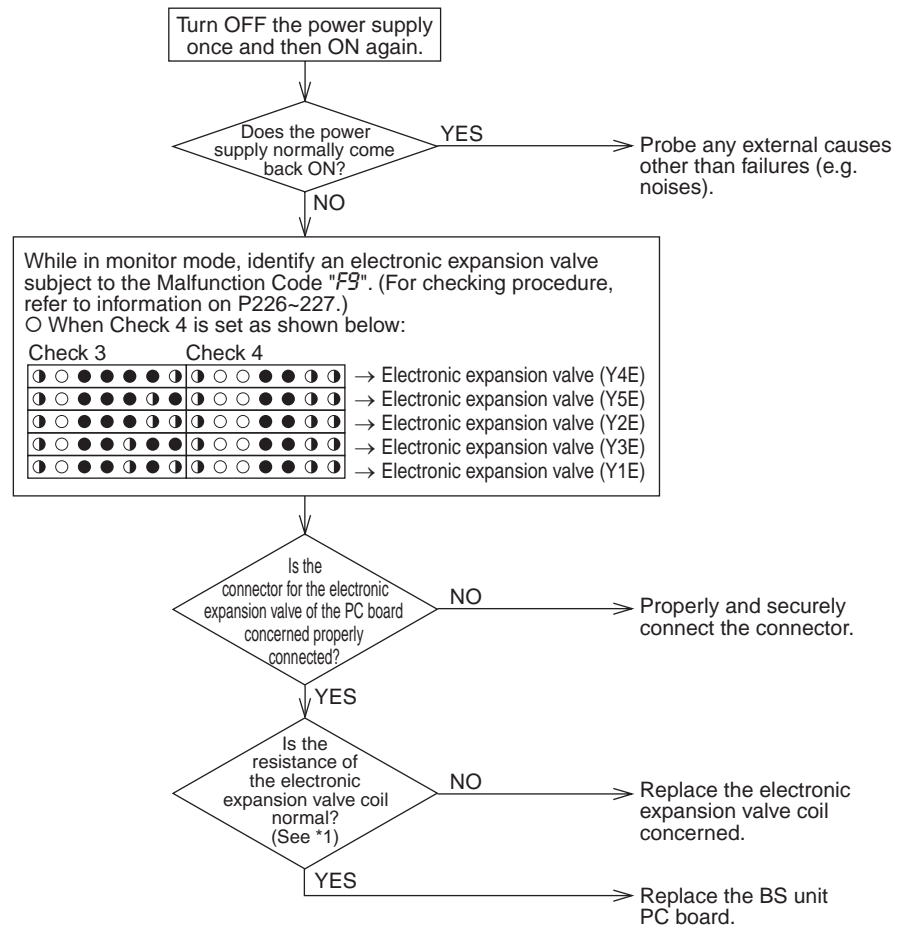

*1: Procedure for checking the electronic expansion valve for the drive unit coil.
 Disconnect the electronic expansion valve connector (X7A) from the PC board, and then make measurement of resistance and check for continuity between the connector pins to make judgment.

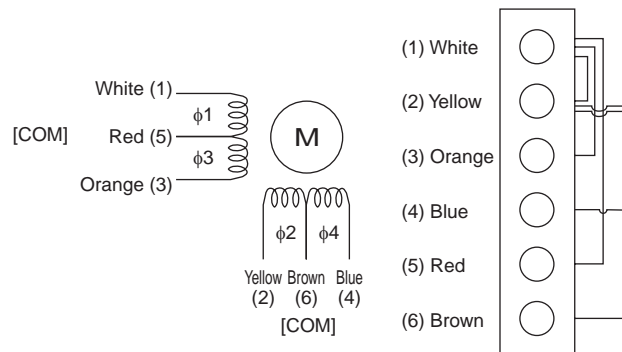

- The normal states are as follows:
- ① No continuity between Pins (1) and (2)
 - ② Approx. 300Ω resistance between Pins (1) and (3)
 - ③ Approx. 150Ω resistance between Pins (1) and (5)
 - ④ Approx. 300Ω resistance between Pins (2) and (4)
 - ⑤ Approx. 150Ω resistance between Pins (2) and (6)

3.23 “H7” Outdoor Unit: Abnormal Outdoor Fan Motor Signal

Remote Control Display	<i>H7</i>
Applicable Models	REYQ8P~48P
Method of Malfunction Detection	Detection of abnormal signal from fan motor.
Malfunction Decision Conditions	In case of detection of abnormal signal at starting fan motor.
Supposed Causes	<ul style="list-style-type: none">■ Abnormal fan motor signal (circuit malfunction)■ Broken, short or disconnection connector of fan motor connection cable■ Fan Inverter PC board malfunction (A2P)

Troubleshooting



Caution

Be sure to turn off power switch before connect or disconnect connector, or parts damage may be occurred.

Check the fan motor corresponding to the malfunction code "H7" in the monitor mode.
 (Refer to P226~227 for how to check)
 When check 3 shows as follows:
 [●][○][●][●][●][●] ? Fan motor 1 (M1F)
 When check 3 shows as follows:
 [○][○][●][●][●][○] ? Fan motor 2 (M2F)
 Identify outdoor unit based on Check 4.
 [○][○][○][●][●][※][※]
 Explanation for "※※"

● ●	Master unit
● ○	Slave unit 1
○ ●	Slave unit 2
○ ○	System

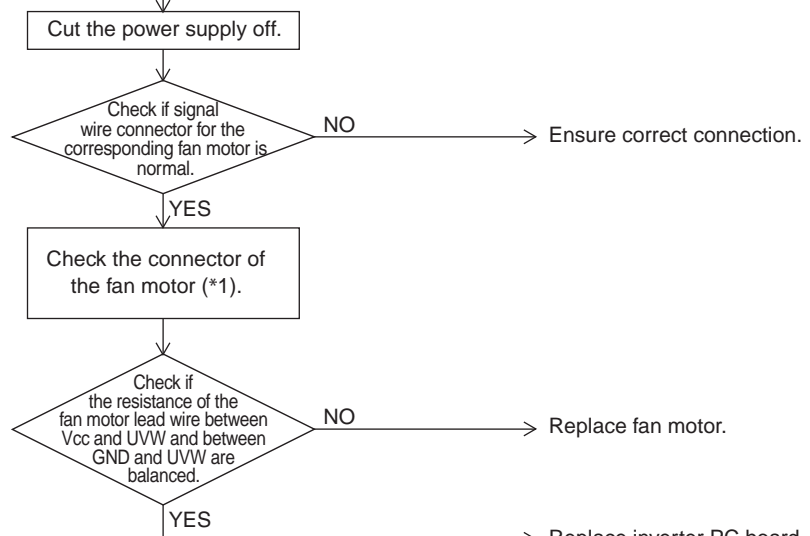

*1. Check procedure for fan motor connector

- (1) Power OFF the fan motor.
- (2) Remove the connector (X2A or X4A) on the PC board to measure the following resistance value.
 Judgment criteria: resistance value between each phase is within ±20%

- For fan motor 1: replace inverter PC board (A2P)
- For fan motor 2: replace fan inverter PC board (A5P)

Connector for signal wires (X2A or X4A)

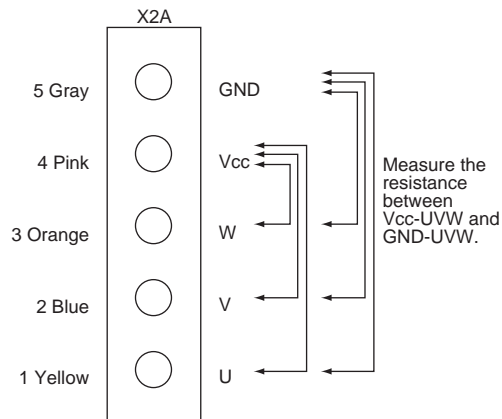

(V2799)

3.24 “H9” Outdoor Unit: Malfunction of Thermistor (R1T) for Outdoor Air

Remote Control Display	H9
Applicable Models	REYQ8P~48P
Method of Malfunction Detection	Malfunction is detected from the temperature detected by the outdoor air thermistor.
Malfunction Decision Conditions	When the outside air temperature thermistor has short circuit or open circuit.
Supposed Causes	<ul style="list-style-type: none"> ■ Defective thermistor connection ■ Defect of thermistor (R1T) for outdoor air ■ Defect of outdoor unit PC board (A1P)

Troubleshooting

 **Caution** Be sure to turn off power switch before connect or disconnect connector, or parts damage may be occurred.

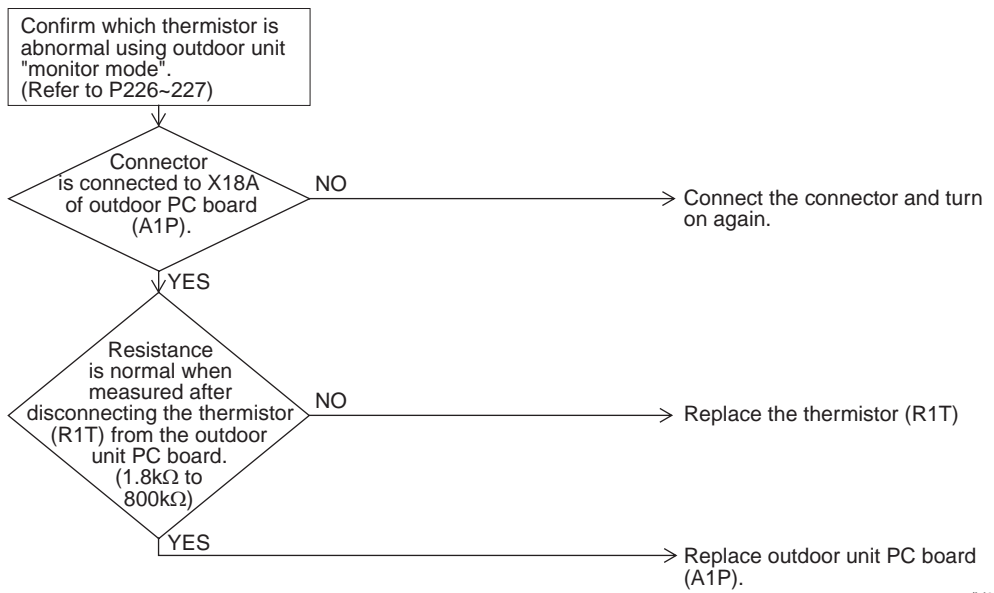

(V3070)



* Refer to “Thermistor Resistance / Temperature Characteristics” table on P417.

3.25 “J2” Outdoor Unit: Current Sensor Malfunction

Remote Control Display	J2
Applicable Models	REYQ8P~48P
Method of Malfunction Detection	Malfunction is detected according to the current value detected by current sensor.
Malfunction Decision Conditions	When the current value detected by current sensor becomes 5A or lower, or 40A or more during standard compressor operation.
Supposed Causes	<ul style="list-style-type: none"> ■ Faulty current sensor (A6P, A8P) ■ Faulty outdoor unit PC board ■ Defective compressor

Troubleshooting

 **Caution** Be sure to turn off power switch before connect or disconnect connector, or parts damage may be occurred.

Check the current sensor corresponding to the malfunction code “J2” in the monitor mode.
 (Refer to P226~227 for how to check)

○ Check 4 shows as follows:
 → Current sensor for constant rate compressor 1

○ Check 4 shows as follows:
 → Current sensor for constant rate compressor 2

○ Explanation for “※※”

● ●	Master unit
● ○	Slave unit 1
○ ●	Slave unit 2
○ ○	System

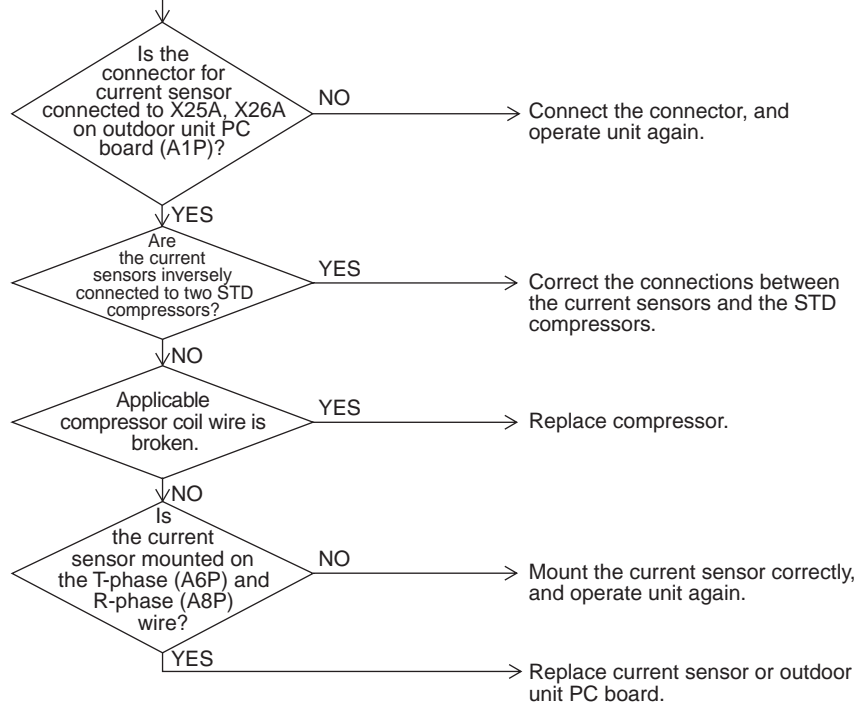

(V3071)

3.26 “J3” Outdoor Unit: Malfunction of Discharge Pipe Thermistor (R31, 32T, 33T)

Remote Control Display	J3
Applicable Models	REYQ8P~48P
Method of Malfunction Detection	Malfunction is detected from the temperature detected by discharge pipe temperature thermistor.
Malfunction Decision Conditions	When a short circuit or an open circuit in the discharge pipe temperature thermistor is detected.
Supposed Causes	<ul style="list-style-type: none"> ■ Defect of thermistor (R31T, R32T, R33T) for outdoor unit discharge pipe ■ Defect of outdoor unit PC board (A1P) ■ Defect of thermistor connection

Troubleshooting

 **Caution** Be sure to turn off power switch before connect or disconnect connector, or parts damage may be occurred.

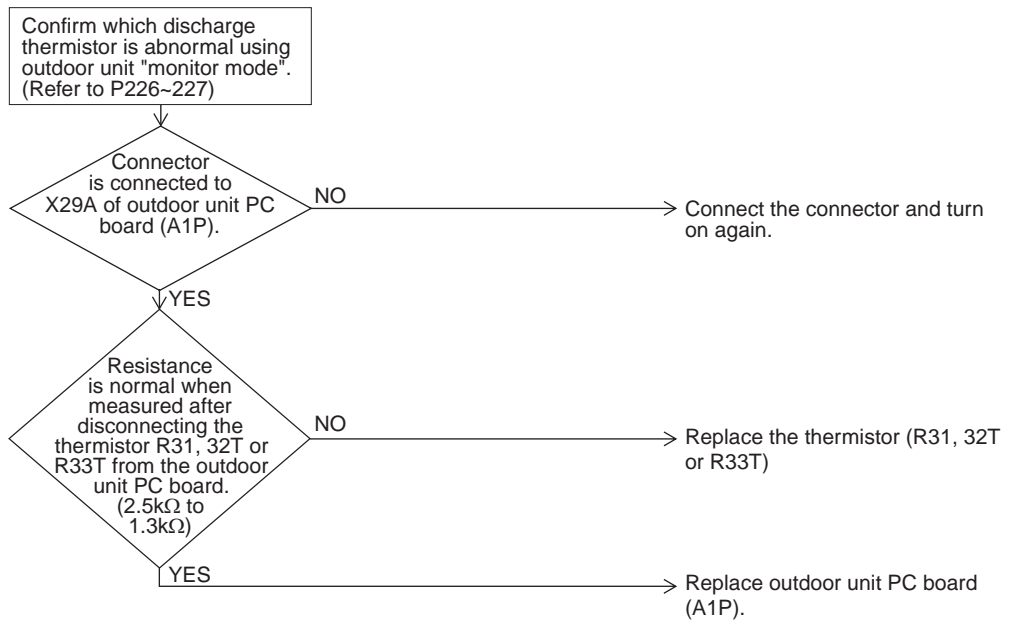

(V3072)

The alarm indicator is displayed when the fan is being used also.



* Refer to “Thermistor Resistance / Temperature Characteristics” table on P418.

3.27 “J4” Outdoor Unit: Malfunction of Temperature Sensor for Heat Exchanger Gas (R2T or R11T)

Remote Control Display	J4
Applicable Models	REYQ8P~48P
Method of Malfunction Detection	Detect malfunction based on the temperature detected by each thermistor.
Malfunction Decision Conditions	In operation, when a thermistor is disconnected or short circuits.
Supposed Causes	<ul style="list-style-type: none"> ■ Defective connection of thermistor ■ Defective thermistor ■ Defective outdoor unit PC board

Troubleshooting

 **Caution** Be sure to turn off power switch before connect or disconnect connector, or parts damage may be occurred.

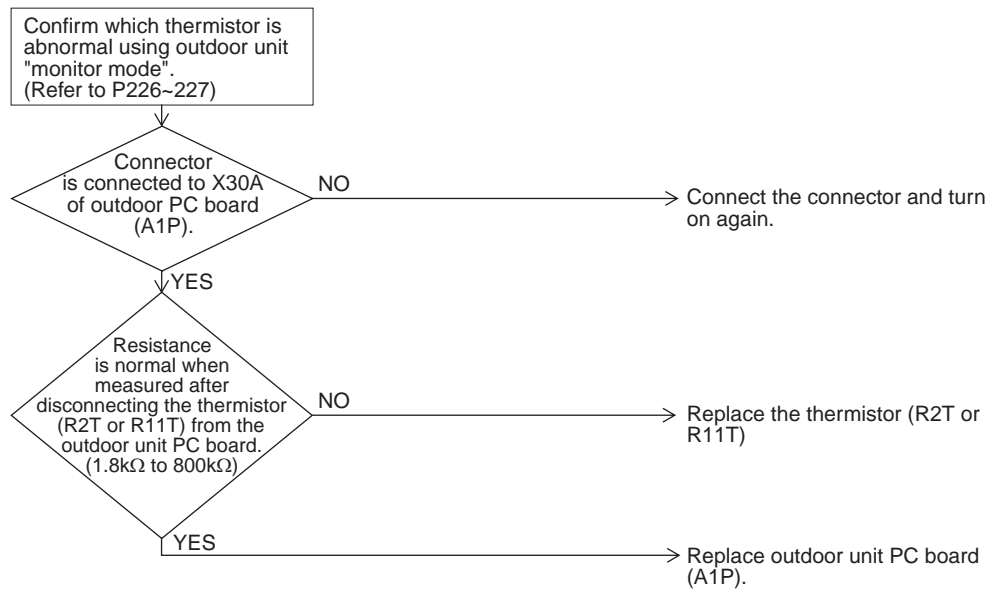

(V3070)



* Refer to “Thermistor Resistance / Temperature Characteristics” table on P417.

3.28 “J5” Outdoor Unit: Malfunction of Thermistor (R8T or R10T) for Suction Pipe

Remote Control Display	J5
Applicable Models	REYQ8P~48P
Method of Malfunction Detection	Malfunction is detected from the temperature detected by the suction pipe temperature thermistor.
Malfunction Decision Conditions	When a short circuit or an open circuit in the suction pipe temperature thermistor is detected.
Supposed Causes	<ul style="list-style-type: none"> ■ Defect of thermistor (R8T or R10T) for outdoor unit suction pipe ■ Defect of outdoor unit PC board (A1P) ■ Defect of thermistor connection

Troubleshooting



Caution Be sure to turn off power switch before connect or disconnect connector, or parts damage may be occurred.

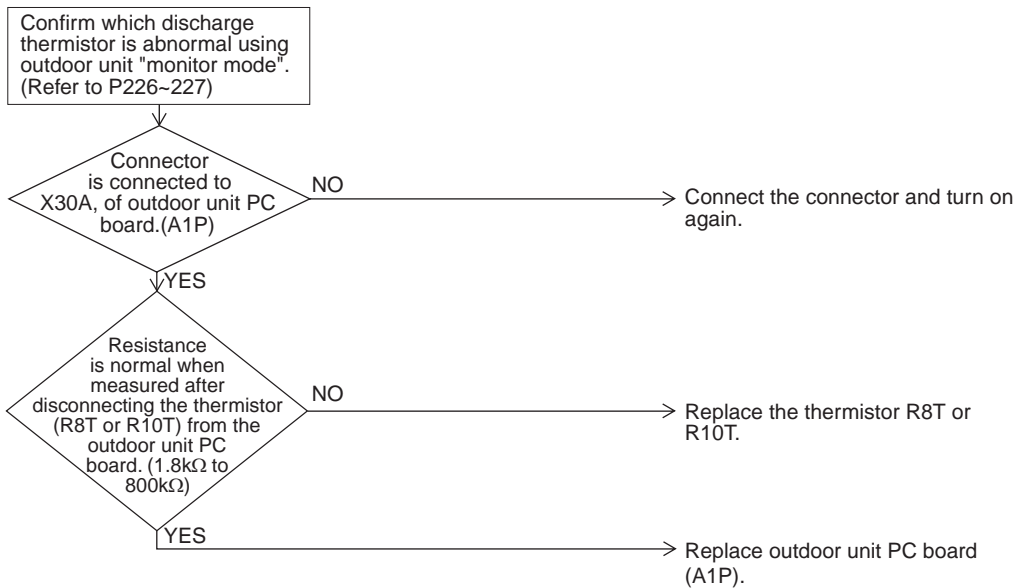

(V3073)



* Refer to “Thermistor Resistance / Temperature Characteristics” table on P417.

3.29 “J5” Outdoor Unit: Malfunction of Thermistor (R4T or R12T) for Outdoor Unit Heat Exchanger

Remote Control Display	J5
Applicable Models	REYQ8P~48P
Method of Malfunction Detection	Malfunction is detected from the temperature detected by the heat exchanger thermistor.
Malfunction Decision Conditions	When a short circuit or an open circuit in the heat exchange thermistor is detected.
Supposed Causes	<ul style="list-style-type: none"> ■ Defect of thermistor (R4T or R12T) for outdoor unit coil ■ Defect of outdoor unit PC board (A1P) ■ Defect of thermistor connection

Troubleshooting

 **Caution** Be sure to turn off power switch before connect or disconnect connector, or parts damage may be occurred.

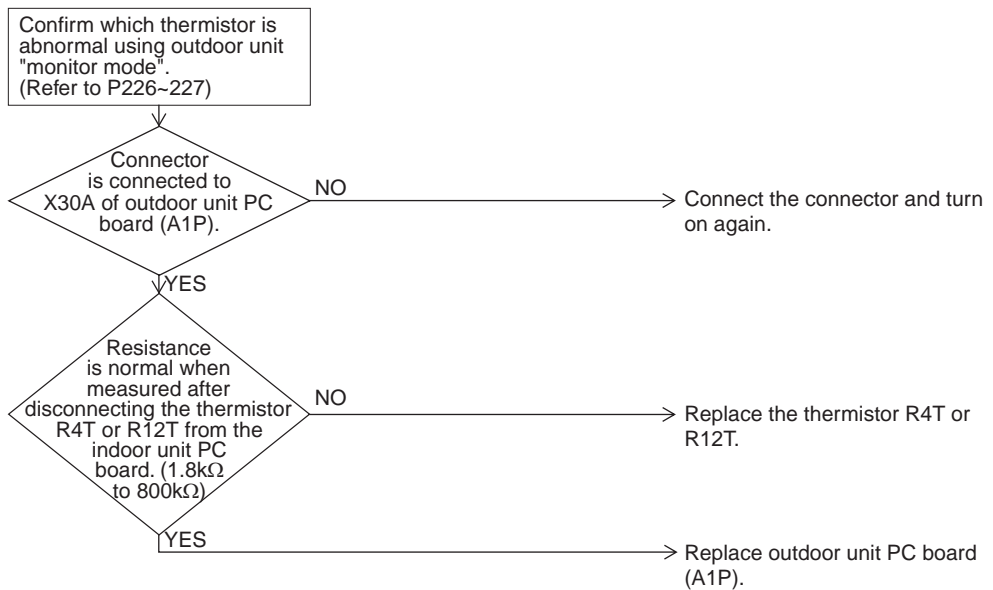

(V3074)



* Refer to “Thermistor Resistance / Temperature Characteristics” table on P417.

3.30 “J7” Outdoor Unit: Malfunction of Liquid Pipe Thermistor 1 (R6T), (R9T) or (R14T)

Remote Control Display	J7
Applicable Models	REYQ8P~48P
Method of Malfunction Detection	Malfunction is detected according to the temperature detected by liquid pipe thermistor.
Malfunction Decision Conditions	When the liquid pipe thermistor is short circuited or open.
Supposed Causes	<ul style="list-style-type: none"> ■ Faulty liquid pipe thermistor 1 (R6T), (R9T) or (R14T) ■ Faulty outdoor unit PC board ■ Defect of thermistor connection

Troubleshooting

 **Caution** Be sure to turn off power switch before connect or disconnect connector, or parts damage may be occurred.

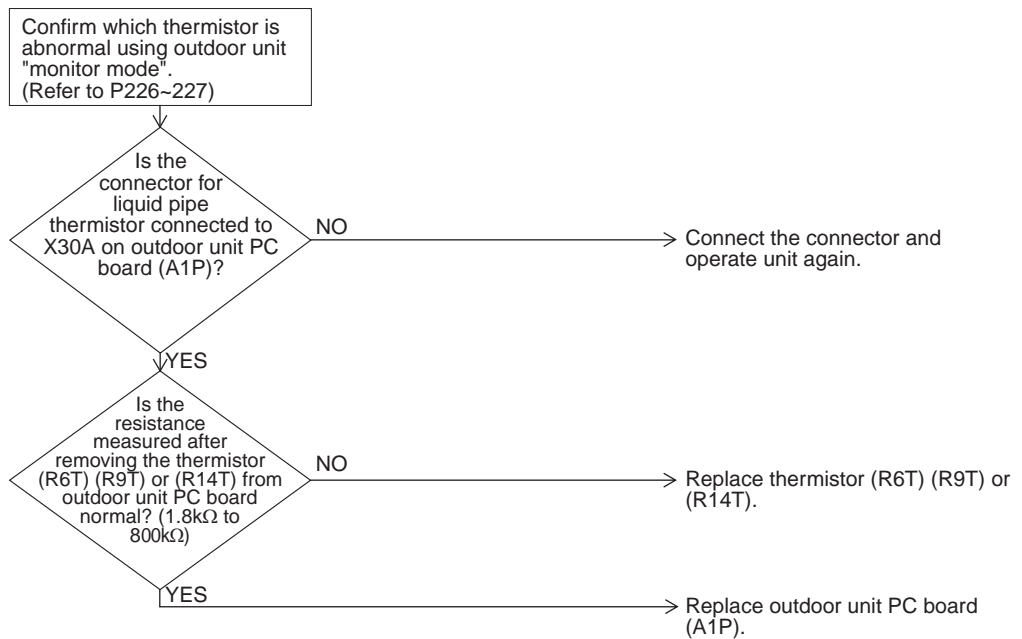

(V3075)



* Refer to “Thermistor Resistance / Temperature Characteristics” table on P417.

3.31 “JB” Outdoor Unit: Malfunction of Liquid Pipe Thermistor 2 (R7T or R15T)

Remote Control Display	JB
Applicable Models	REYQ8P~48P
Method of Malfunction Detection	Malfunction is detected according to the temperature detected by liquid pipe thermistor.
Malfunction Decision Conditions	When the liquid pipe thermistor is short circuited or open.
Supposed Causes	<ul style="list-style-type: none"> ■ Faulty liquid pipe thermistor 2 (R7T or R15T) ■ Faulty outdoor unit PC board ■ Defect of thermistor connection

Troubleshooting

 **Caution** Be sure to turn off power switch before connect or disconnect connector, or parts damage may be occurred.

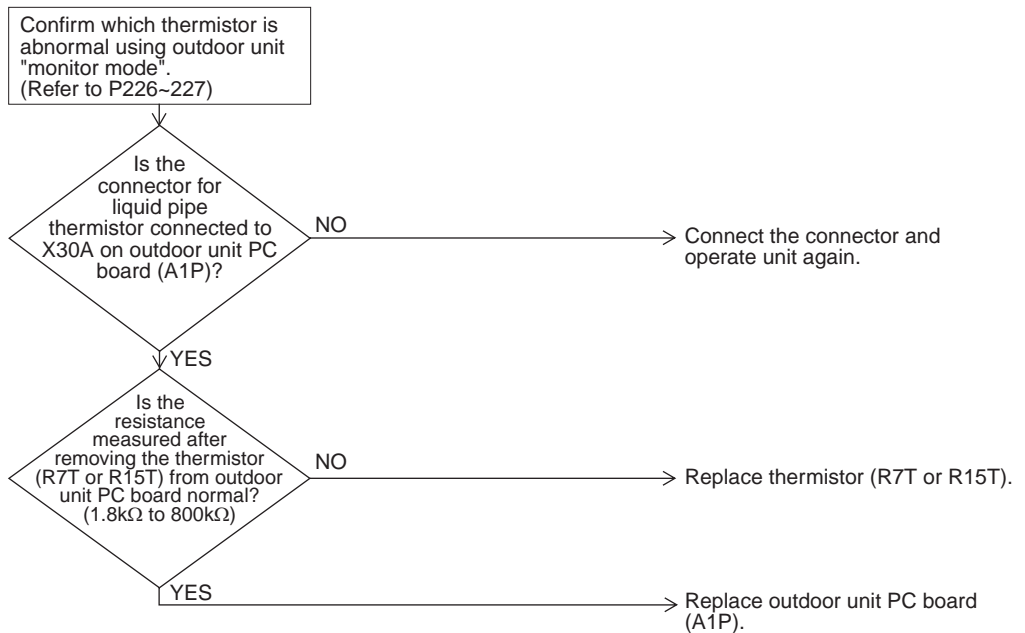

(V3075)



* Refer to “Thermistor Resistance / Temperature Characteristics” table on P417.

3.32 “J9” Outdoor Unit: Malfunction of Subcooling Heat Exchanger Gas Pipe Thermistor (R5T or R13T)

Remote Control Display	J9
Applicable Models	REYQ8P~48P
Method of Malfunction Detection	Malfunction is detected according to the temperature detected by subcooling heat exchanger gas pipe thermistor.
Malfunction Decision Conditions	When the subcooling heat exchanger gas pipe thermistor is short circuited or open.
Supposed Causes	<ul style="list-style-type: none"> ■ Faulty subcooling heat exchanger gas pipe thermistor (R5T or R13T) ■ Faulty outdoor unit PC board

Troubleshooting

 **Caution** Be sure to turn off power switch before connect or disconnect connector, or parts damage may be occurred.

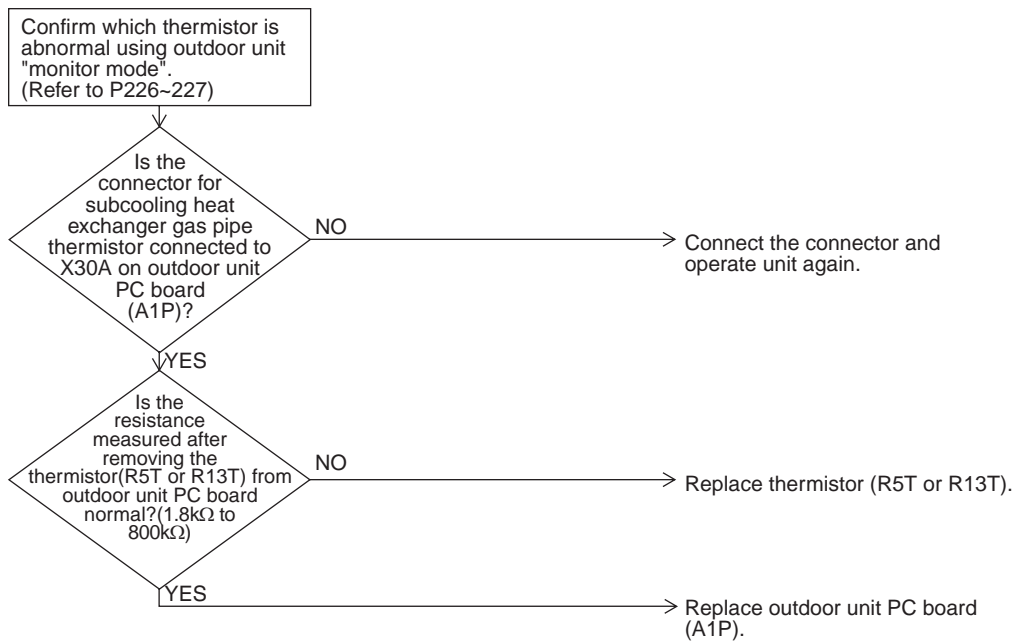

(V3075)



* Refer to “Thermistor Resistance / Temperature Characteristics” table on P417.

3.33 “JA” Outdoor Unit: Malfunction of High Pressure Sensor

Remote Control Display	<i>JA</i>
Applicable Models	REYQ8P~48P
Method of Malfunction Detection	Malfunction is detected from the pressure detected by the high pressure sensor.
Malfunction Decision Conditions	When the high pressure sensor is short circuit or open circuit. (Not less than 4.22MPa, or 0.01MPa and below)
Supposed Causes	<ul style="list-style-type: none">■ Defect of high pressure sensor system■ Connection of low pressure sensor with wrong connection.■ Defect of outdoor unit PC board.■ Defective connection of high pressure sensor

Troubleshooting



Caution Be sure to turn off power switch before connect or disconnect connector, or parts damage may be occurred.

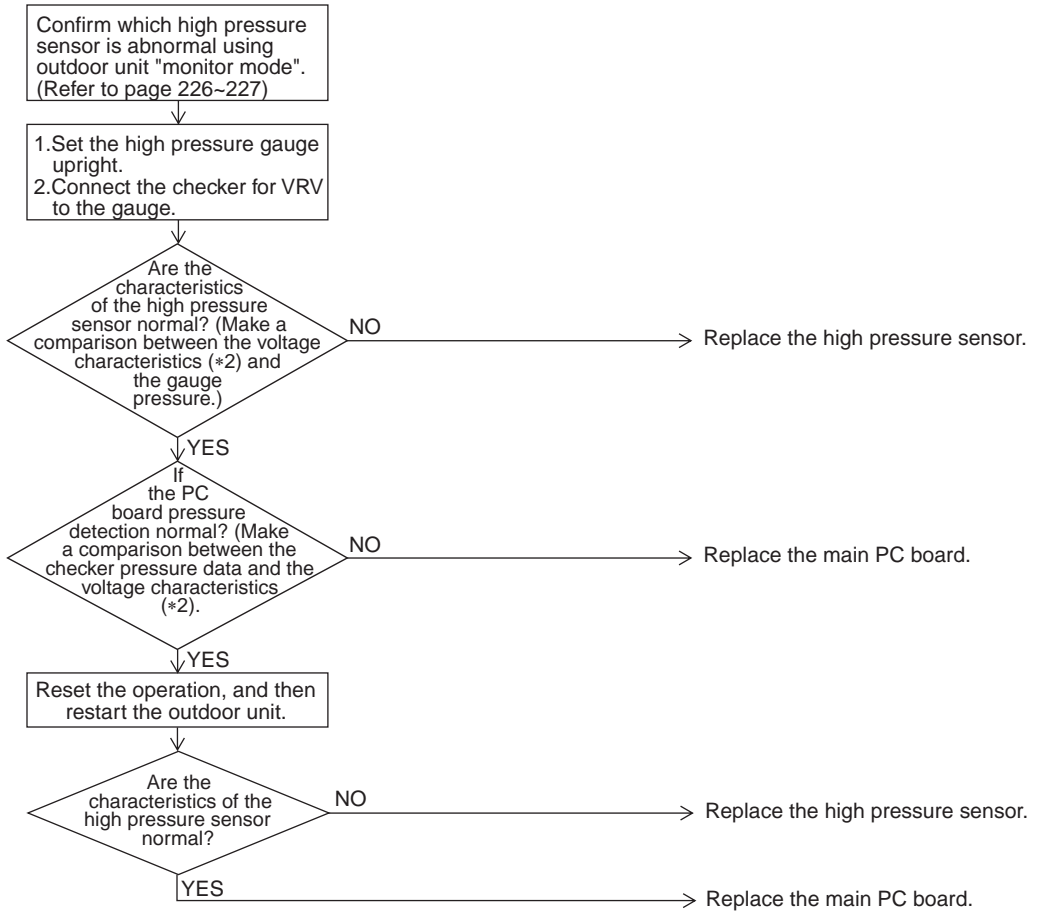

*1: Pressure sensor subject to malfunction code

Malfunction code	Pressure sensor subject to malfunction code	Electric symbol
JA	High pressure sensor	S1NPH

(V2806)

*2: Voltage measurement point

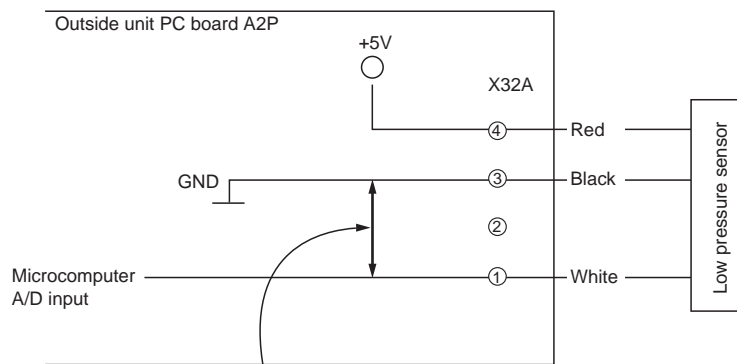

(V2807)



*2: Refer to "Pressure Sensor, Pressure / Voltage Characteristics" table on P419.

3.34 “JL” Outdoor Unit: Malfunction of Low Pressure Sensor

Remote Control Display	JL
Applicable Models	REYQ8P~48P
Method of Malfunction Detection	Malfunction is detected from pressure detected by low pressure sensor.
Malfunction Decision Conditions	When the low pressure sensor is short circuit or open circuit. (Not less than 1.77MPa, or -0.01MPa and below)
Supposed Causes	<ul style="list-style-type: none"> ■ Defect of low pressure sensor system ■ Connection of high pressure sensor with wrong connection. ■ Defect of outdoor unit PC board. ■ Defective connection of low pressure sensor

Troubleshooting



Caution Be sure to turn off power switch before connect or disconnect connector, or parts damage may be occurred.

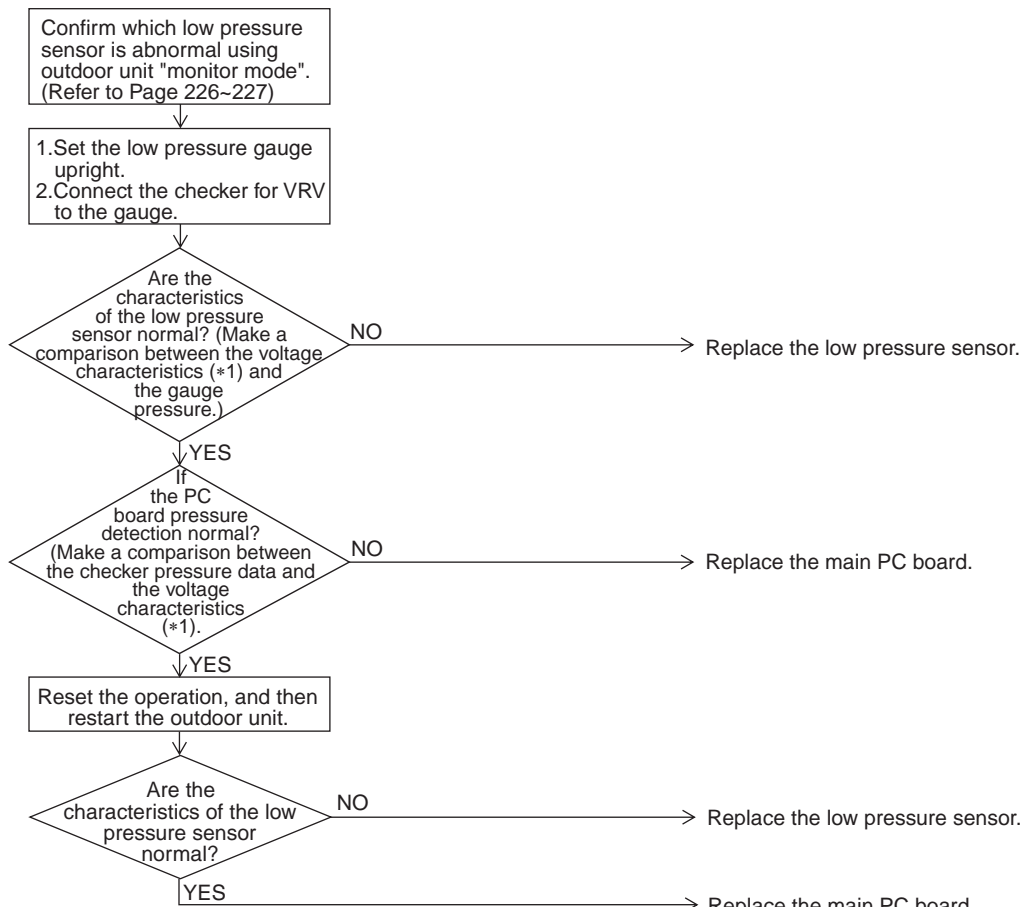

(V2808)

*1: Voltage measurement point

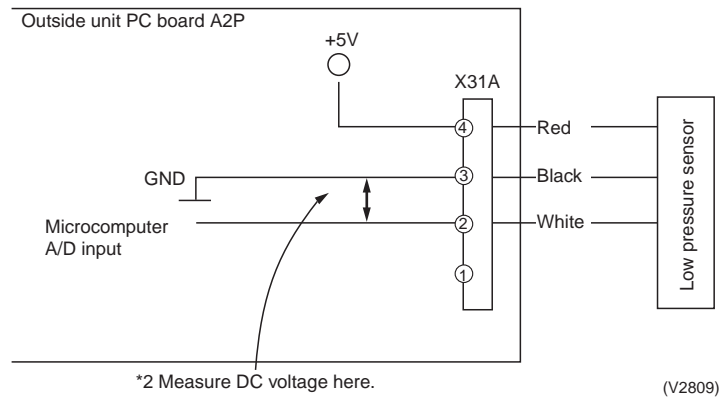

*2: Refer to "Pressure Sensor, Pressure / Voltage Characteristics" table on P419.

3.35 “L1” Outdoor Unit: Defective Inverter PC Board

Remote Control Display	L1
Applicable Models	REYQ8P~48P
Method of Malfunction Detection	Malfunction is detected based on the current value during waveform output before starting compressor. Malfunction is detected based on the value from current sensor during synchronous operation when starting the unit.
Malfunction Decision Conditions	Overcurrent (OCP) flows during waveform output. Malfunction of current sensor during synchronous operation. IPM failure.
Supposed Causes	<ul style="list-style-type: none">■ Inverter PC board (A2P)<ul style="list-style-type: none">● IPM failure● Current sensor failure● Drive circuit failure

Troubleshooting



Caution

Be sure to turn off power switch before connect or disconnect connector, or parts damage may be occurred.

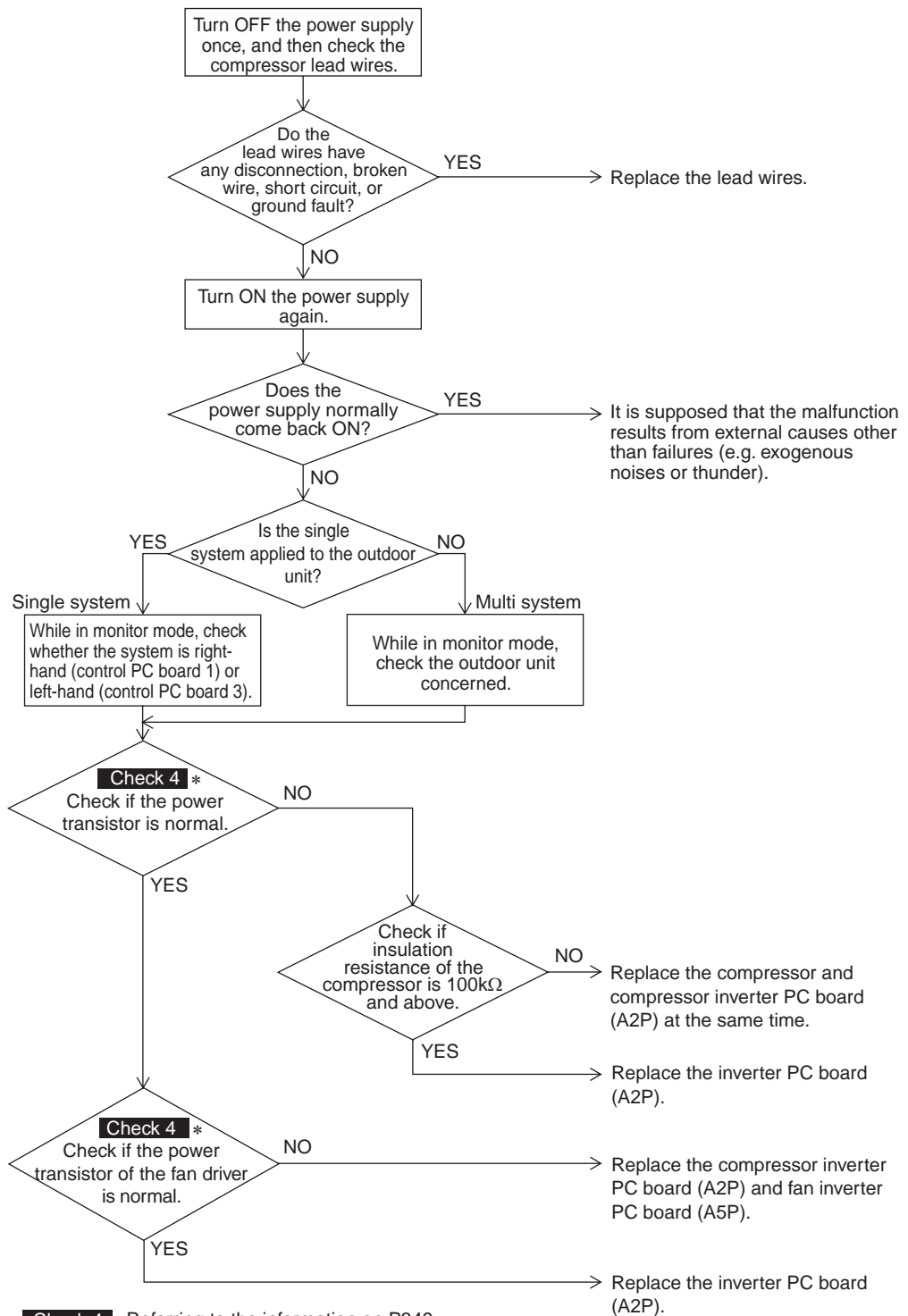

* **Check 4** : Referring to the information on P349.

*1. List of Inverter PC boards

Model	Name	Electric symbol
REYQ 8, 10,12P	Compressor inverter PC board	A5P
	Fan inverter PC board	A6P, A7P
REYQ 14, 16P	Compressor inverter PC board	A4P, A7P
	Fan inverter PC board	A6P, A9P
REMQ 8, 10, 12P	Compressor inverter PC board	A4P
	Fan inverter PC board	A5P
REMQ 14, 16P	Compressor inverter PC board	A4P
	Fan inverter PC board	A5P, A7P

3.36 “L4” Outdoor Unit: Malfunction of Inverter Radiating Fin Temperature Rise

Remote Control
Display

L4

Applicable
Models

REYQ8P~48P

Method of
Malfunction
Detection

Fin temperature is detected by the thermistor of the radiation fin.

Malfunction
Decision
Conditions

When the temperature of the inverter radiation fin increases above 87°C.

Supposed
Causes

- Actuation of fin thermal (Actuates above 87°C)
- Defect of inverter PC board
- Defect of fin thermistor

Troubleshooting



Caution

Be sure to turn off power switch before connect or disconnect connector, or parts damage may be occurred.

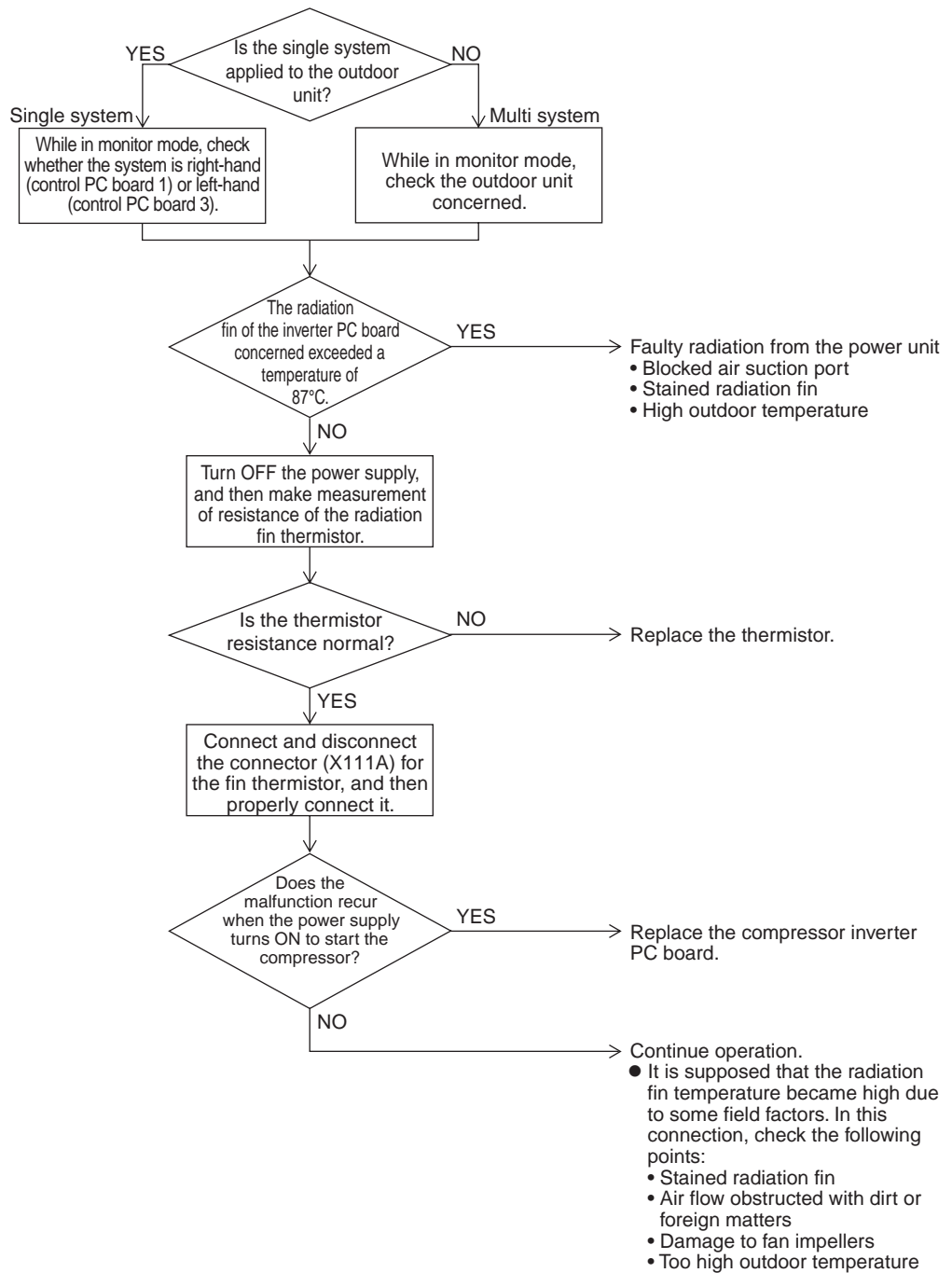

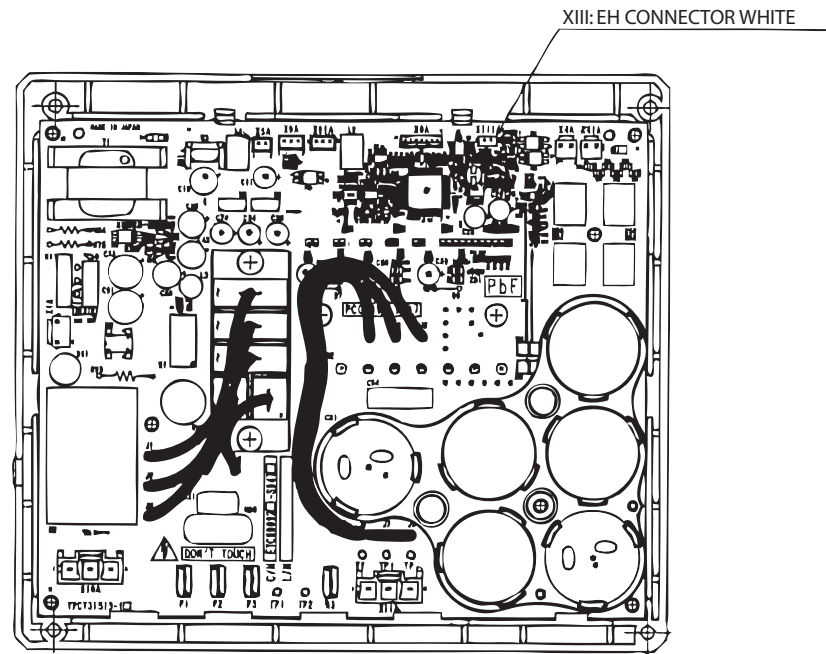

Inverter PC board for compressor



* Refer to "Thermistor Resistance / Temperature Characteristics" table on P417.

3.37 “L5” Outdoor Unit: Momentary Overcurrent of Inverter Compressor

Remote Control Display	L5
Applicable Models	REYQ8P~48P
Method of Malfunction Detection	Malfunction is detected from current flowing in the power transistor.
Malfunction Decision Conditions	When an excessive current flows in the power transistor. (Instantaneous overcurrent also causes activation.)
Supposed Causes	<ul style="list-style-type: none"> ■ Defect of compressor coil (disconnected, defective insulation) ■ Compressor start-up malfunction (mechanical lock) ■ Defect of inverter PC board

Troubleshooting

Compressor inspection



Caution

Be sure to turn off power switch before connect or disconnect connector, or parts damage may be occurred.

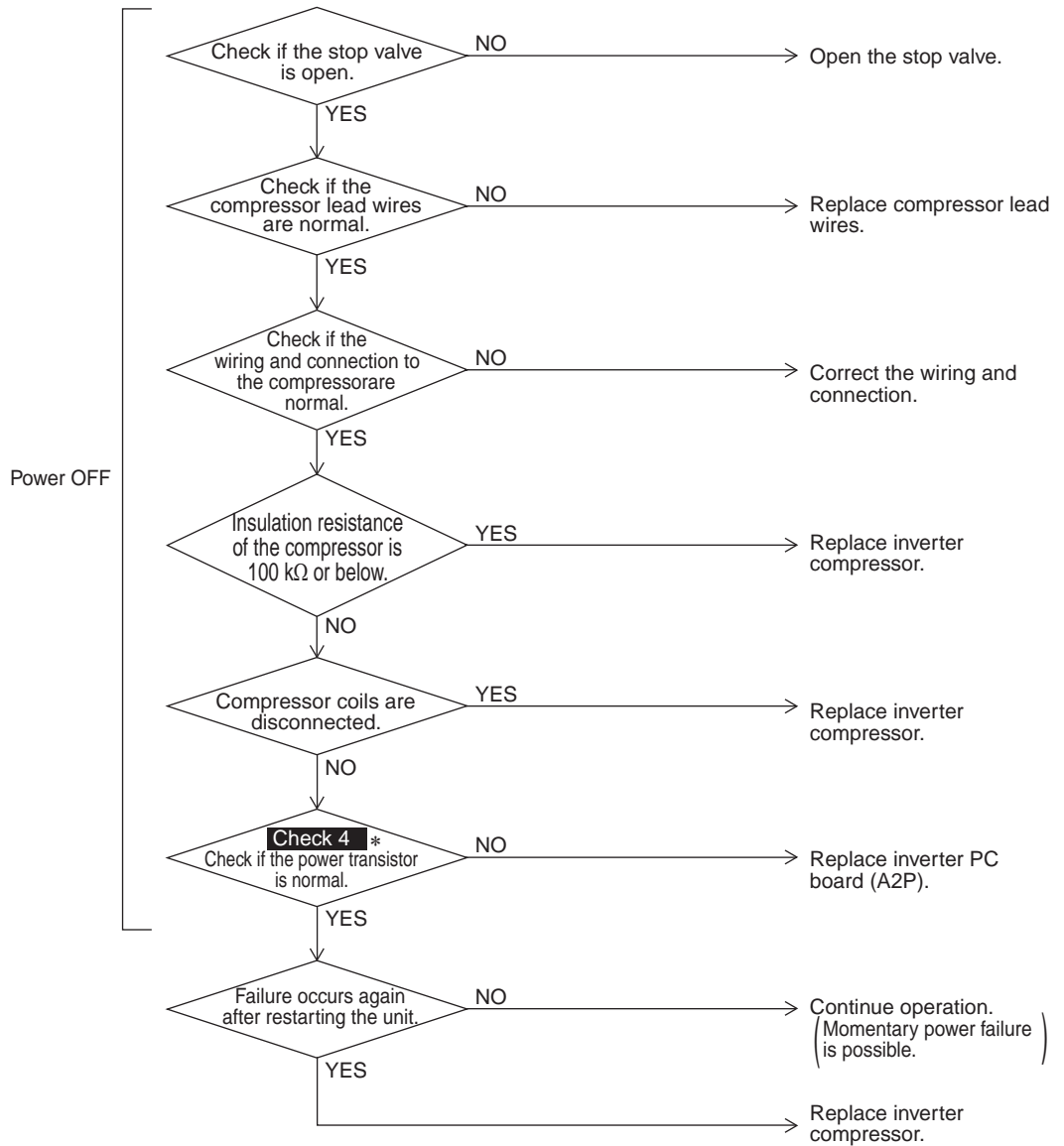

* **Check 4** : Referring to the information on P349.

3.38 “LB” Outdoor Unit: Momentary Overcurrent of Inverter Compressor

Remote Control Display	LB
Applicable Models	REYQ8P~48P
Method of Malfunction Detection	Malfunction is detected by current flowing in the power transistor.
Malfunction Decision Conditions	When overload in the compressor is detected. (Inverter secondary current 16.1A) (1) 19.0A and over continues for 5 seconds. (2) 16.1A and over continues for 260 seconds.
Supposed Causes	<ul style="list-style-type: none"> ■ Compressor overload ■ Compressor coil disconnected ■ Defect of inverter PC board ■ Faulty compressor

Troubleshooting

Output current check



Caution

Be sure to turn off power switch before connect or disconnect connector, or parts damage may be occurred.

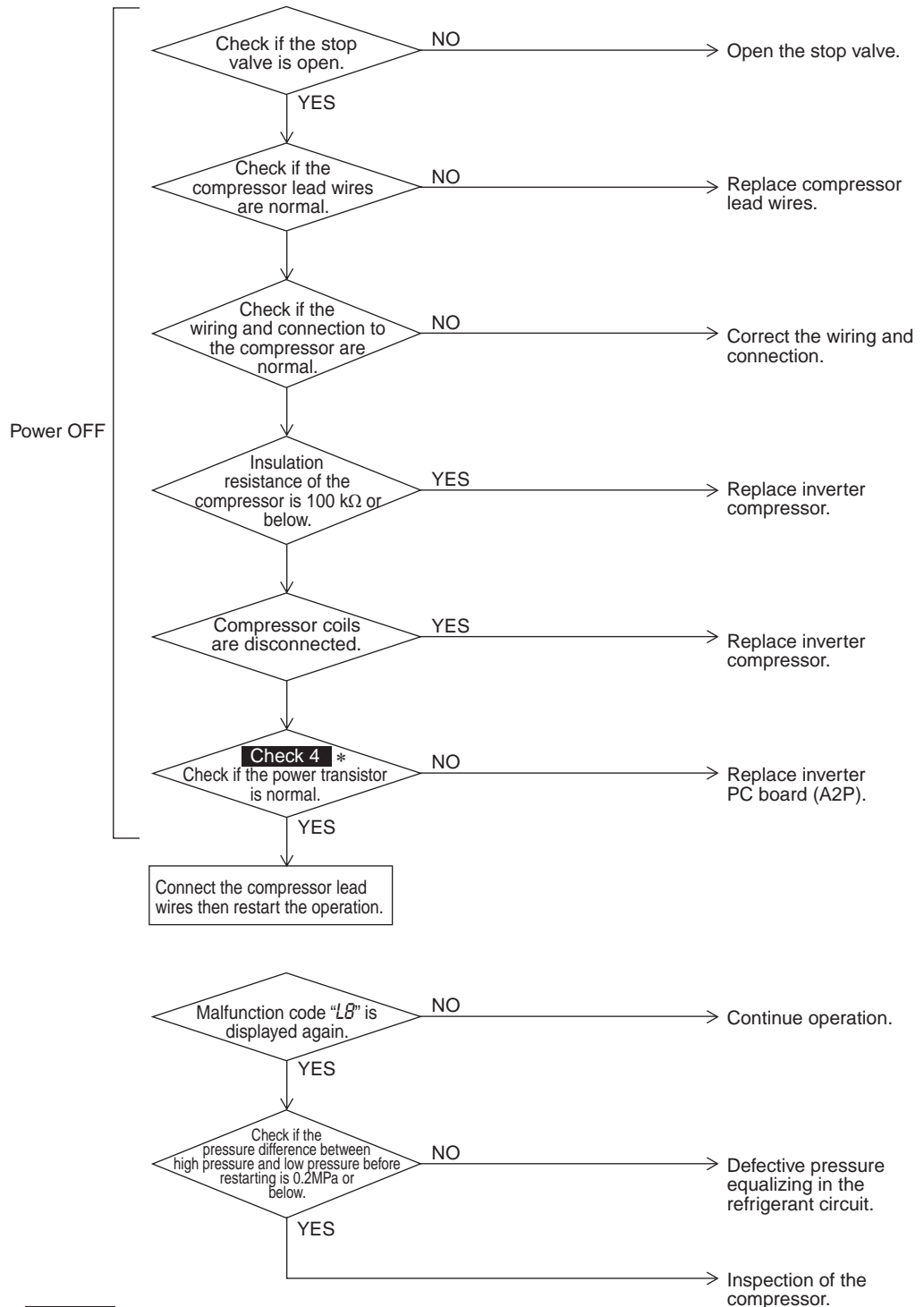

* **Check 4** : Referring to the information on P349.

3.39 “L9” Outdoor Unit: Inverter Compressor Starting Failure

Remote Control Display	L9
Applicable Models	REYQ8P~48P
Method of Malfunction Detection	Detect the failure based on the signal waveform of the compressor.
Malfunction Decision Conditions	Starting the compressor does not complete.
Supposed Causes	<ul style="list-style-type: none">■ Failure to open the stop valve■ Defective compressor■ Wiring connection error to the compressor■ Large pressure difference before starting the compressor■ Defective inverter PC board

Troubleshooting



Caution

Be sure to turn off power switch before connect or disconnect connector, or parts damage may be occurred.

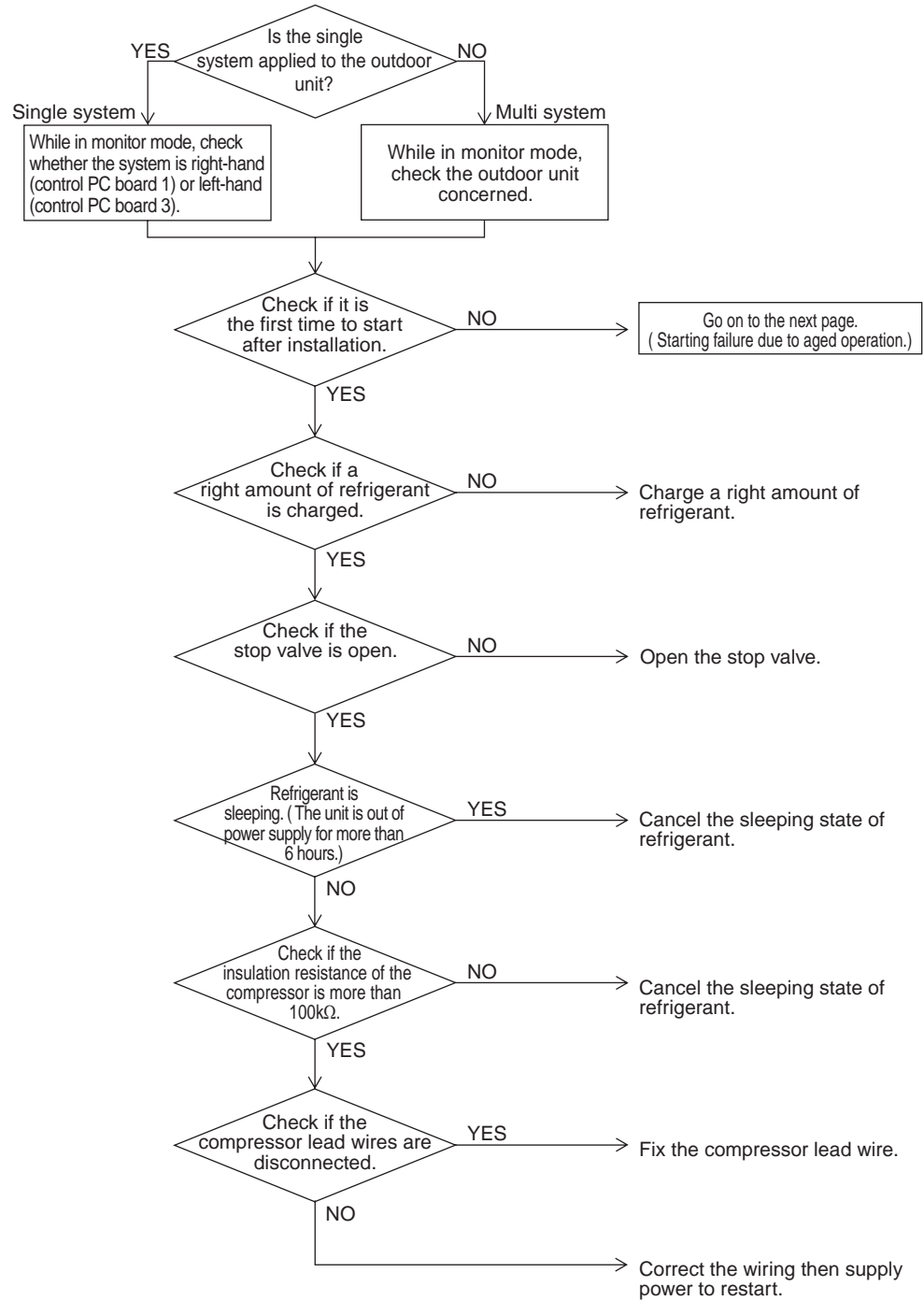

Troubleshooting

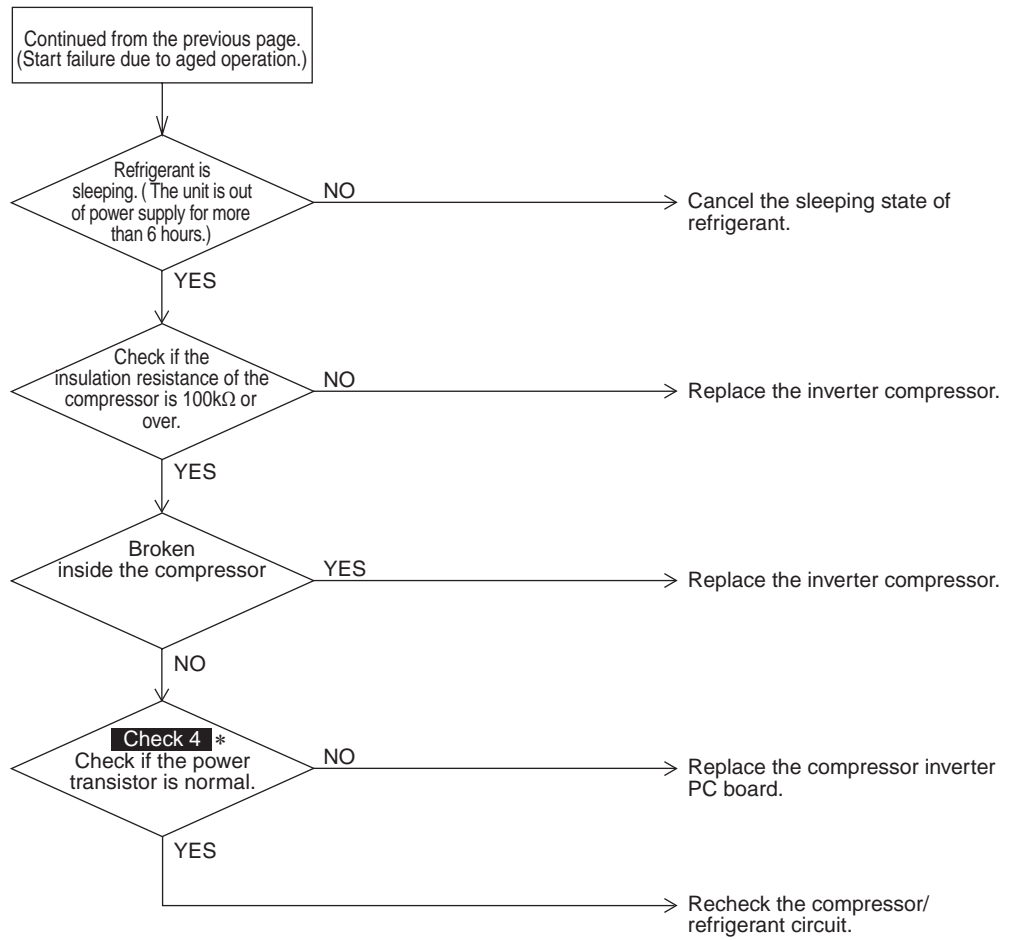

3.40 “LC” Outdoor Unit: Malfunction of Transmission between Inverter and Control PC Board

Remote Control Display	LC
Applicable Models	REYQ8P~48P
Method of Malfunction Detection	Check the communication state between inverter PC board and control PC board by micro-computer.
Malfunction Decision Conditions	When the correct communication is not conducted in certain period.
Supposed Causes	<ul style="list-style-type: none"> ■ Malfunction of connection between the inverter PC board and outdoor main PC board ■ Defect of outdoor main PC board (transmission section) ■ Defect of inverter PC board ■ Defect of noise filter ■ Faulty fan inverter ■ Incorrect type of inverter PC board ■ Faulty inverter compressor ■ Faulty fan motor ■ External factor (noise etc.)

Troubleshooting

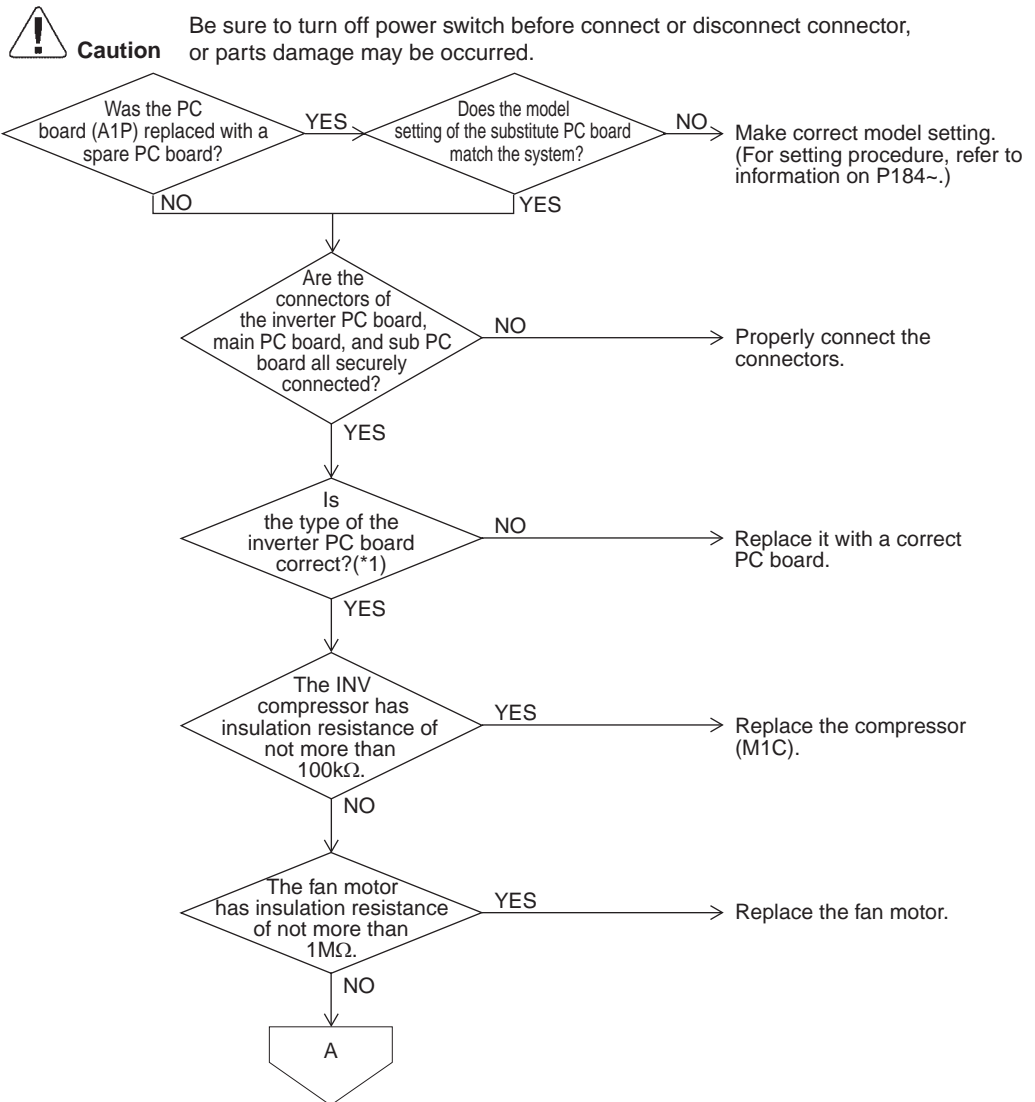

*1. List of Inverter PC boards

	Comp1	Comp2	FAN1	FAN2
REYQ8PY1	PC0509-1	—	PC0511-3	PC0511-4
REYQ10PY1	PC0509-1	—	PC0511-3	PC0511-4
REYQ12PY1	PC0509-1	—	PC0511-3	PC0511-4
REYQ14PY1	PC0509-1	PC0509-1	PC0511-1	PC0511-1
REYQ16PY1	PC0509-1	PC0509-1	PC0511-1	PC0511-1
REMQ8PY1	PC0509-1	—	PC0511-1	—
REMQ10PY1	PC0509-1	—	PC0511-1	—
REMQ12PY1	PC0509-1	—	PC0511-1	—
REMQ14PY1	PC0509-1	—	PC0511-3	PC0511-4
REMQ16PY1	PC0509-1	—	PC0511-3	PC0511-4

Troubleshooting

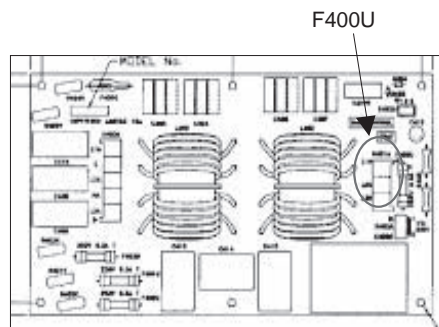
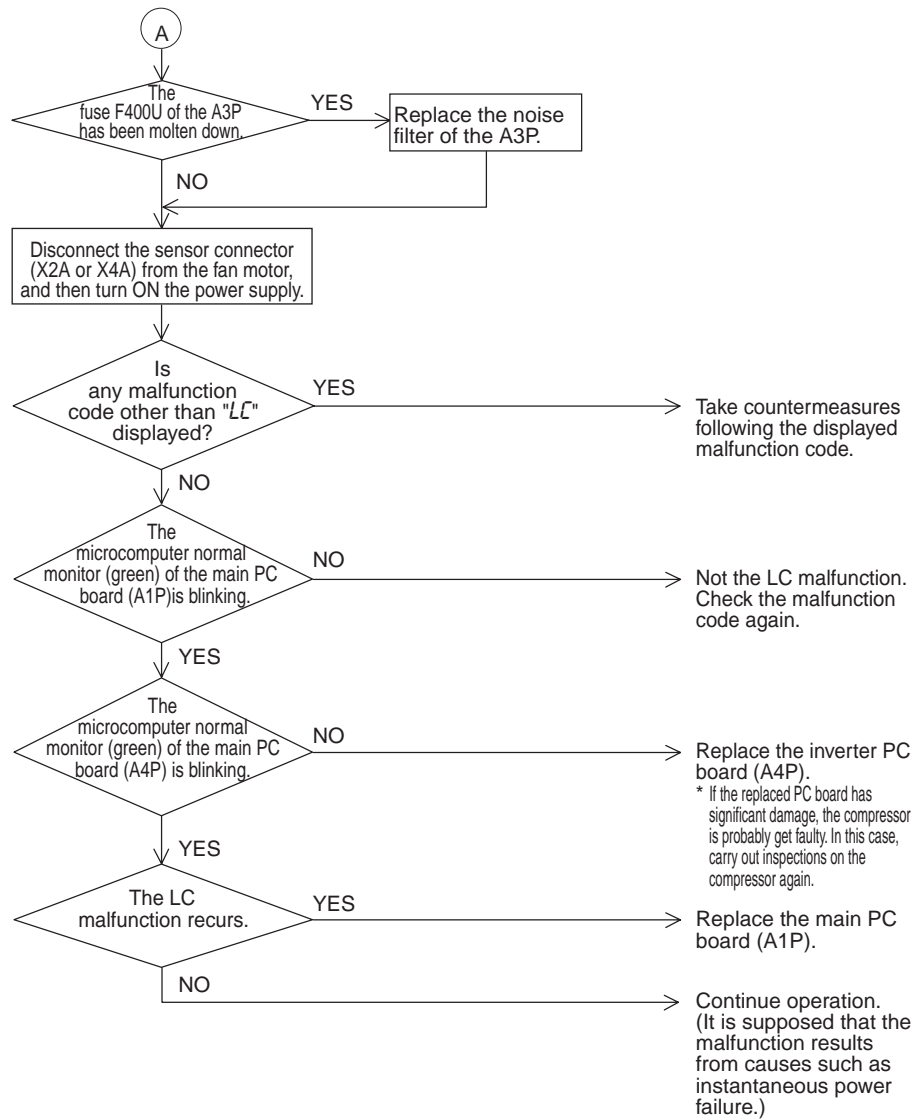

3.41 "P1" Outdoor Unit: Inverter Over-Ripple Protection

Remote Control Display	<i>P1</i>
Applicable Models	REYQ8P~48P
Method of Malfunction Detection	<p>Imbalance in supply voltage is detected in PC board.</p> <p>Imbalance in the power supply voltage causes increased ripple of voltage of the main circuit capacitor in the inverter. Consequently, the increased ripple is detected.</p>
Malfunction Decision Conditions	<p>When the resistance value of thermistor becomes a value equivalent to open or short circuited status.</p> <p>★ Malfunction is not decided while the unit operation is continued. "P1" will be displayed by pressing the inspection button.</p> <p>When the amplitude of the ripple exceeding a certain value is detected for consecutive 4 minutes.</p>
Supposed Causes	<ul style="list-style-type: none"> ■ Open phase ■ Voltage imbalance between phases ■ Defect of main circuit capacitor ■ Defect of inverter PC board ■ Defect of K2 relay in inverter PC board ■ Improper main circuit wiring

Troubleshooting



Caution

Be sure to turn off power switch before connect or disconnect connector, or parts damage may be occurred.

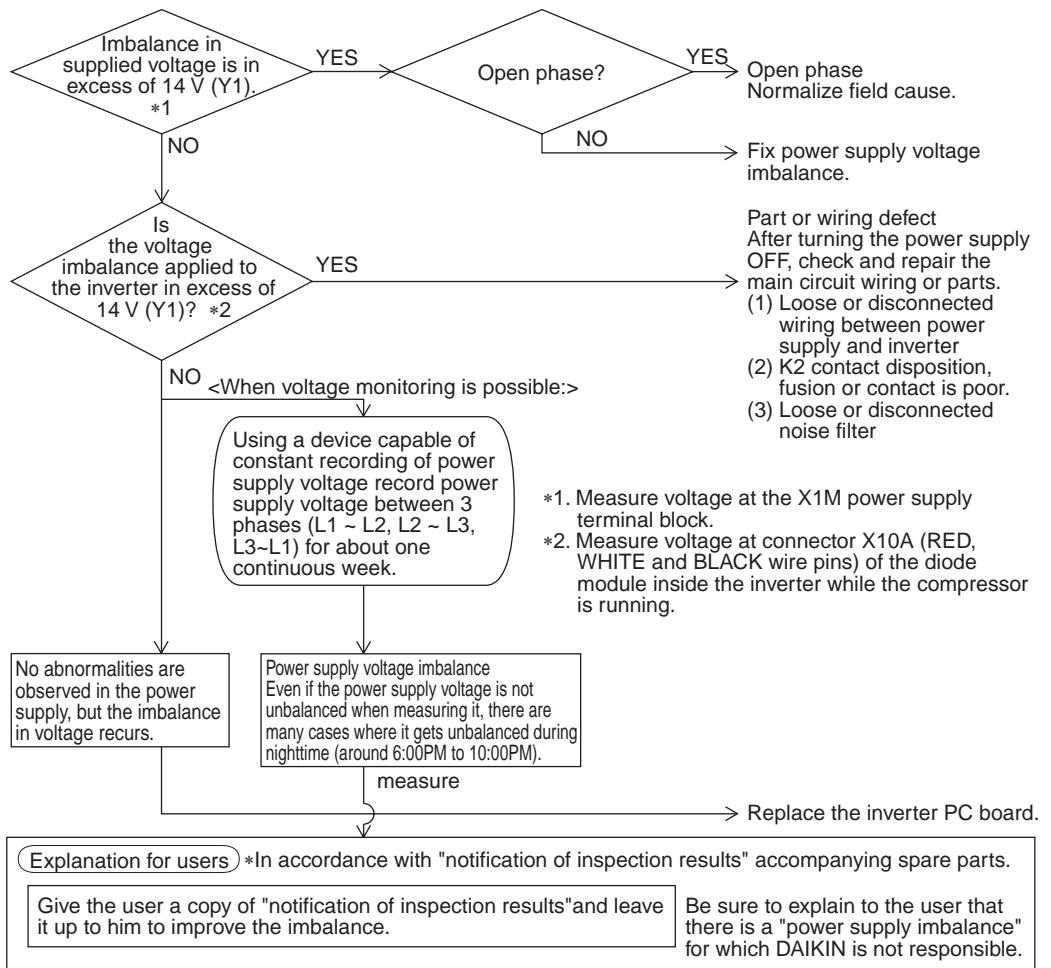

(V2816)

3.42 "P4" Outdoor Unit: Malfunction of Inverter Radiating Fin Temperature Rise Sensor

Remote Control Display	P4
Applicable Models	REYQ8P~48P
Method of Malfunction Detection	Resistance of radiation fin thermistor is detected when the compressor is not operating.
Malfunction Decision Conditions	When the resistance value of thermistor becomes a value equivalent to open or short circuited status. ★ Malfunction is not decided while the unit operation is continued. "P4" will be displayed by pressing the inspection button.
Supposed Causes	<ul style="list-style-type: none"> ■ Defect of radiator fin temperature sensor ■ Defect of inverter PC board ■ Faulty inverter compressor ■ Faulty fan motor

Troubleshooting

 **Caution** Be sure to turn off power switch before connect or disconnect connector, or parts damage may be occurred.

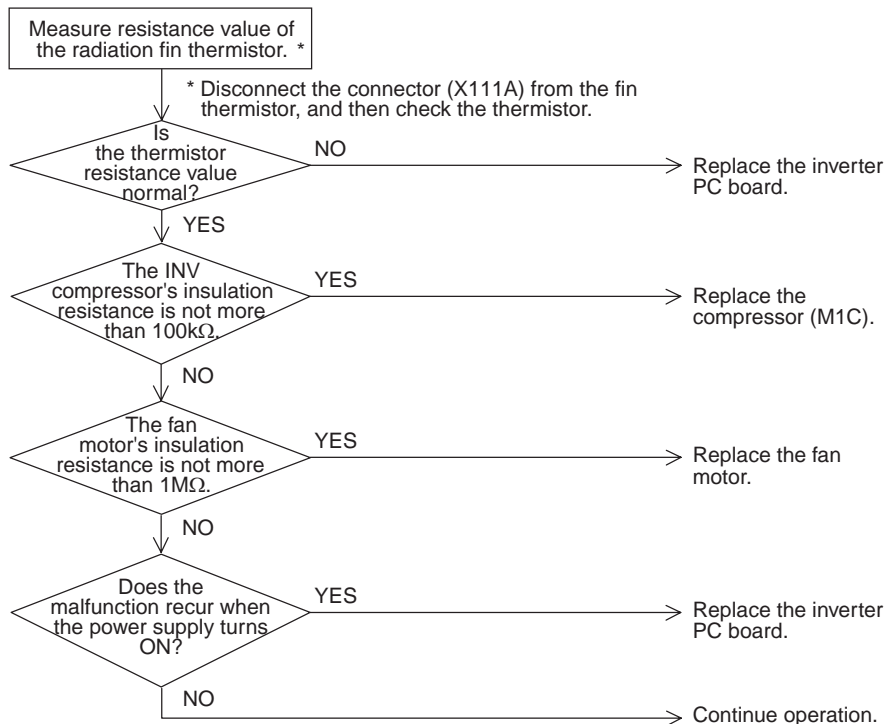

3.43 “PU” Outdoor Unit: Faulty Field Setting after Replacing Main PC Board or Faulty Combination of PC Board

Remote Control Display	<i>PU</i>
Applicable Models	REYQ8P~48P
Method of Malfunction Detection	This malfunction is detected according to communications with the inverter.
Malfunction Decision Conditions	Make judgment according to communication data on whether or not the type of the inverter PC board is correct.
Supposed Causes	<ul style="list-style-type: none"> ■ Faulty (or no) field setting after replacing main PC board ■ Mismatching of type of PC board

Troubleshooting



Caution

Be sure to turn off power switch before connect or disconnect connector, or parts damage may be occurred.

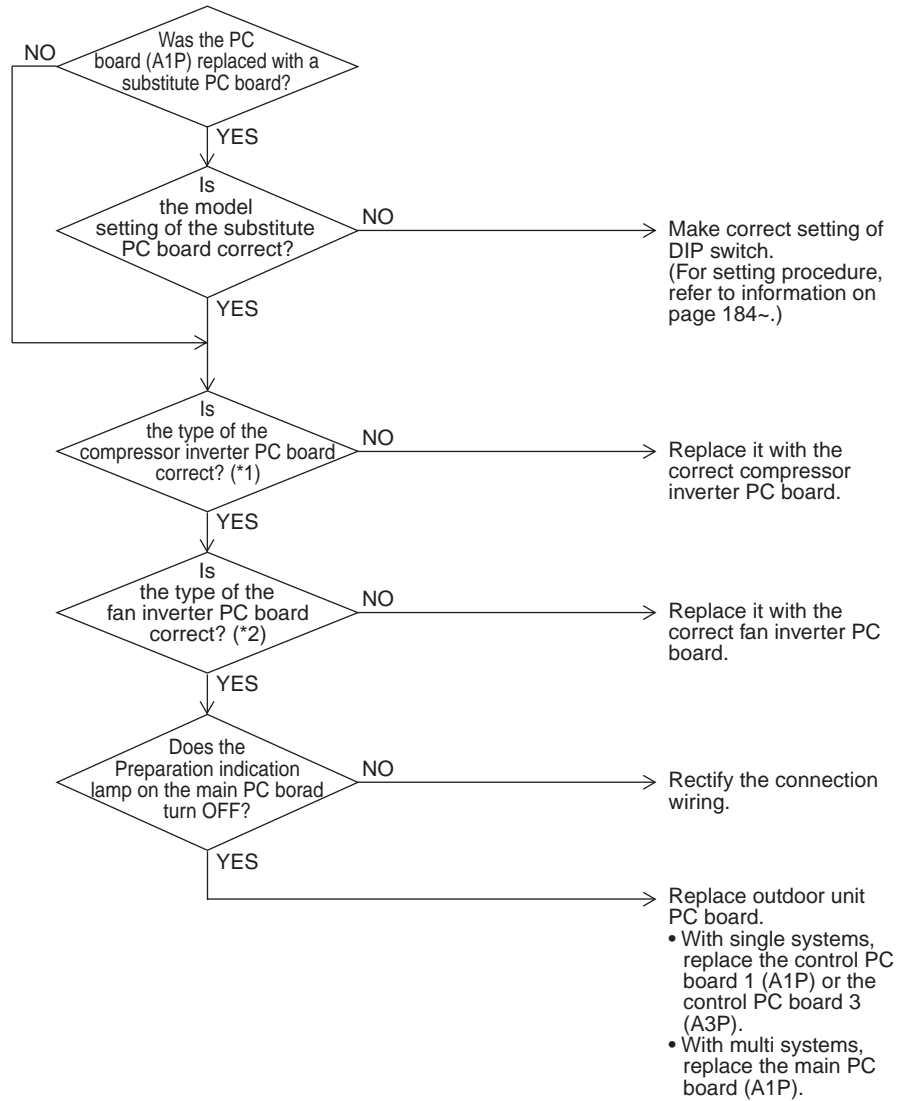

*1. List of Inverter PC boards

	Comp1	Comp2	FAN1	FAN2
REYQ8PY1	PC0509-1	—	PC0511-3	PC0511-4
REYQ10PY1	PC0509-1	—	PC0511-3	PC0511-4
REYQ12PY1	PC0509-1	—	PC0511-3	PC0511-4
REYQ14PY1	PC0509-1	PC0509-1	PC0511-1	PC0511-1
REYQ16PY1	PC0509-1	PC0509-1	PC0511-1	PC0511-1
REMQ8PY1	PC0509-1	—	PC0511-1	—
REMQ10PY1	PC0509-1	—	PC0511-1	—
REMQ12PY1	PC0509-1	—	PC0511-1	—
REMQ14PY1	PC0509-1	—	PC0511-3	PC0511-4
REMQ16PY1	PC0509-1	—	PC0511-3	PC0511-4

3.44 “U0” Outdoor Unit: Gas Shortage Alert

Remote Control Display	U0
Applicable Models	REYQ8P~48P
Method of Malfunction Detection	Detect gas shortage based on the temperature difference between low pressure or suction pipe and heat exchanger.
Malfunction Decision Conditions	<p>[In cooling mode] Low pressure becomes 0.1MPa or below.</p> <p>[In heating mode] The degree of superheat of suction gas becomes 20 degrees and over. $SH = Ts1 - Te$ $Ts1$: Suction pipe temperature detected by thermistor Te : Saturated temperature corresponding to low pressure ★Malfunction is not determined. The unit continues operation.</p>
Supposed Causes	<ul style="list-style-type: none"> ■ Gas shortage or refrigerant clogging (piping error) ■ Defective thermistor (R4T, R7T, R12T, R15T) ■ Defective low pressure sensor ■ Defective outdoor unit PC board (A1P)

Troubleshooting



Caution

Be sure to turn off power switch before connect or disconnect connector, or parts damage may be occurred.

In cooling mode

- ① Set up a pressure gauge at the service port on the low pressure side.
- ② Reset the operation using the remote controller then restart.

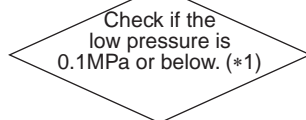

NO

YES

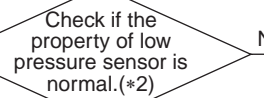

NO

YES

Replace the low pressure sensor.

Replace the main PC board (A1P).

Remove the factor of decreasing low pressure by referring to **Check 6**.

- *1: Check the low pressure value by using pressure gauge in operation.
- *2: Compare the actual measurement value by pressure sensor with the value by the pressure gauge.
(To gain actual measurement value by pressure sensor, measure the voltage at the connector [between (2)-(3)] and then convert the value into pressure referring to P419.)

*1

In heating mode

Reset the operation using the remote control then restart.

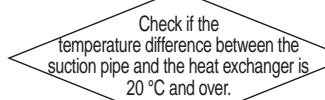

NO

YES

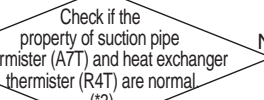

NO

Replace the thermister.

- Replace the main PC board.
- With individual systems, replace the control PC board 1 (A1P) or the control PC board 3 (A3P).
- With multi systems, replace the main PC board (A1P).



Remove the factor of superheating by referring to **Check 3**.

- *3: Compare the thermister resistance value with the value on the surface thermometer.

*2

*1 **Check 6** : Referring to the information on P351.

*2 **Check 3** : Referring to the information on P348.

3.45 “U1” Reverse Phase, Open Phase

Remote Control Display	U1
Applicable Models	REYQ8P~48P
Method of Malfunction Detection	The phase of each phase are detected by reverse phase detection circuit and right phase or reverse phase are judged.
Malfunction Decision Conditions	When a significant phase difference is made between phases.
Supposed Causes	<ul style="list-style-type: none"> ■ Power supply reverse phase ■ Power supply open phase ■ Defect of outdoor PC board (A1P)

Troubleshooting

 **Caution** Be sure to turn off power switch before connect or disconnect connector, or parts damage may be occurred.

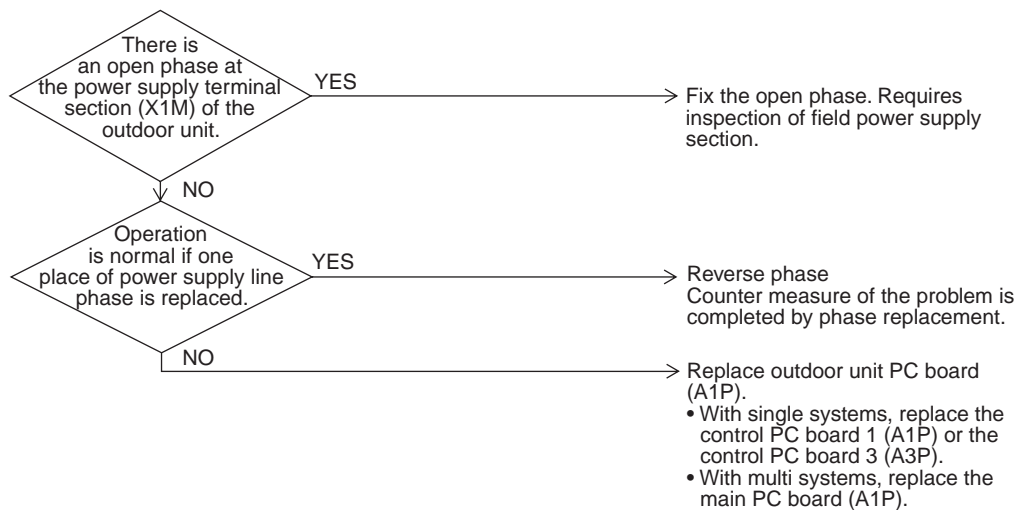

(V2820)

3.46 “U2” Outdoor Unit: Power Supply Insufficient or Instantaneous Failure

Remote Control Display	U2
Applicable Models	REYQ8P~48P
Method of Malfunction Detection	Detection of voltage of main circuit capacitor built in the inverter and power supply voltage.
Malfunction Decision Conditions	When the voltage aforementioned is not less than 780V or not more than 320V, or when the current-limiting voltage does not reach 200V or more or exceeds 740V.
Supposed Causes	<ul style="list-style-type: none"> ■ Power supply insufficient ■ Instantaneous power failure ■ Open phase ■ Defect of inverter PC board ■ Defect of outdoor control PC board ■ Main circuit wiring defect ■ Faulty compressor ■ Faulty fan motor ■ Faulty connection of signal cable

Troubleshooting



Caution Be sure to turn off power switch before connect or disconnect connector, or parts damage may be occurred.

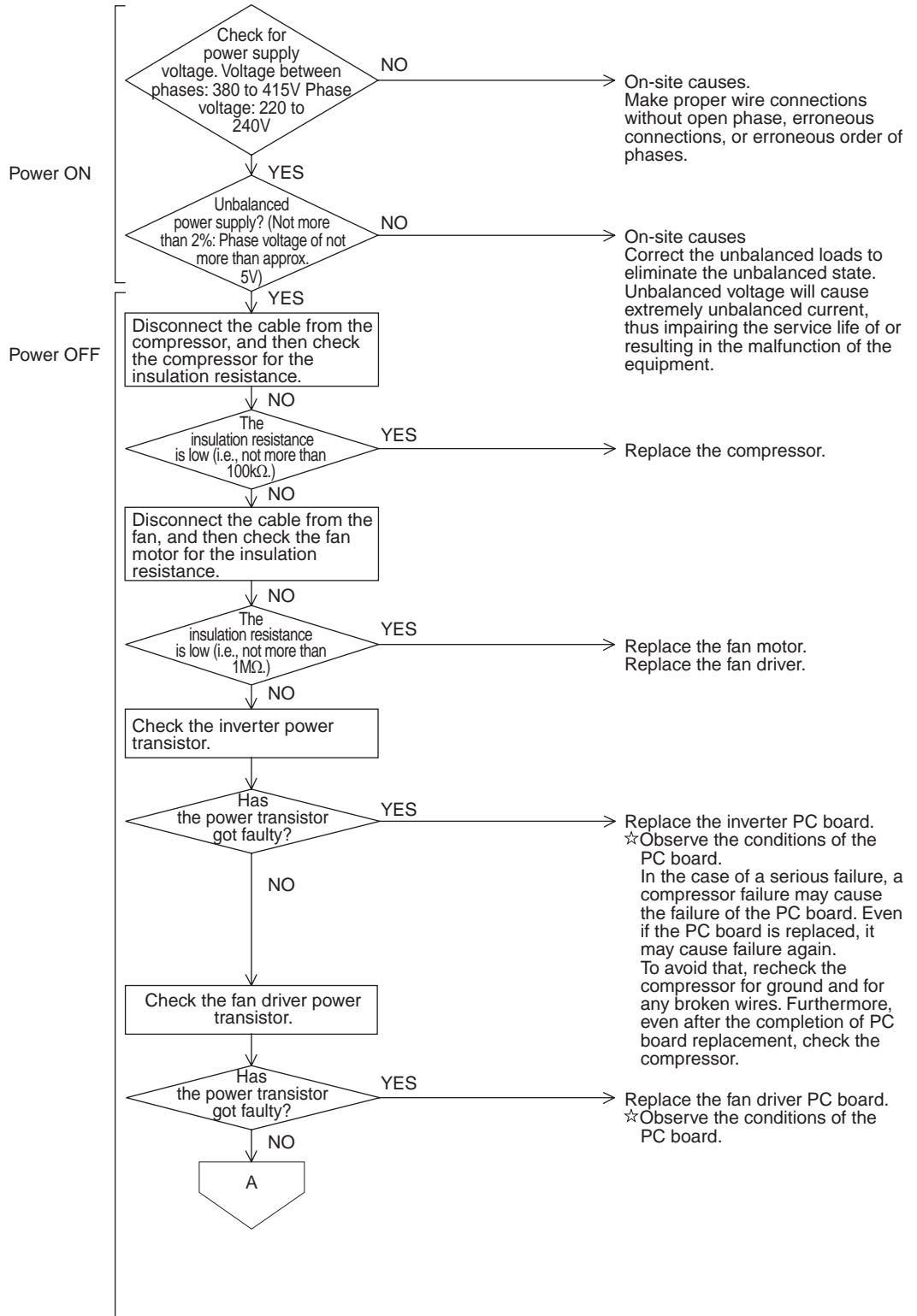

Troubleshooting

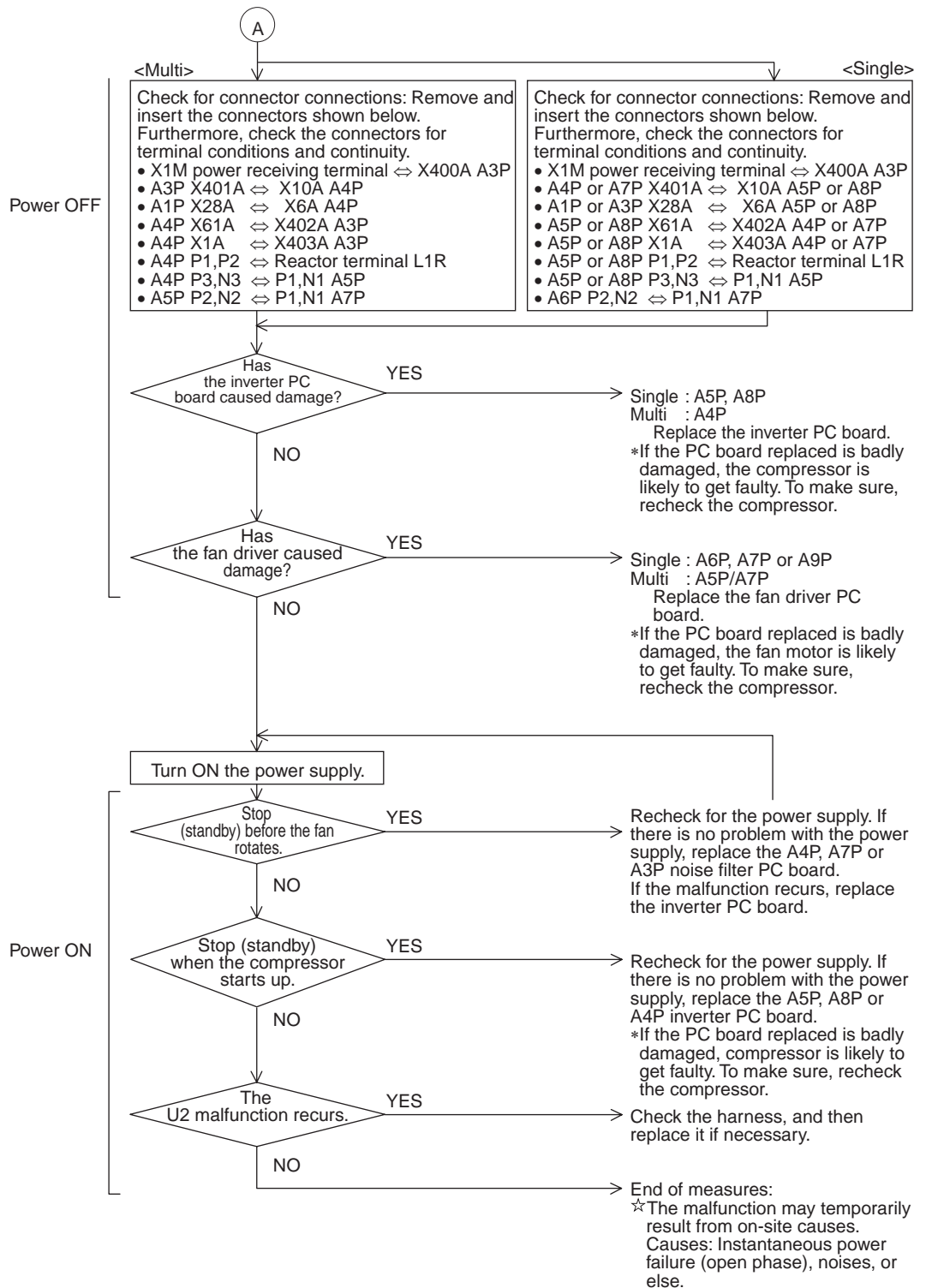

3.47 “U3” Outdoor Unit: Check Operation not Executed

Remote Control Display	U3
Applicable Models	REYQ8P~48P
Method of Malfunction Detection	Check operation is executed or not
Malfunction Decision Conditions	Malfunction is decided when the unit starts operation without check operation.
Supposed Causes	<ul style="list-style-type: none"> ■ Check operation is not executed.
Troubleshooting	

 **Caution** Be sure to turn off power switch before connect or disconnect connector, or parts damage may be occurred.

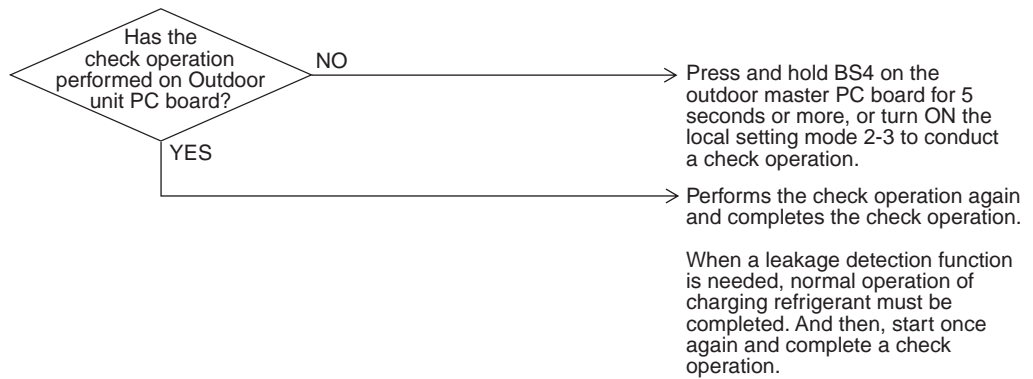

(V3052)

3.48 “U4” Malfunction of Transmission between Indoor Units

Remote Control Display	U4
Applicable Models	All model of indoor unit REYQ8P~48P
Method of Malfunction Detection	Check if the transmission between indoor unit and outdoor unit is correctly executed using microcomputer.
Malfunction Decision Conditions	When transmission is not carried out normally for a certain amount of time
Supposed Causes	<ul style="list-style-type: none">■ Indoor to outdoor, outdoor to outdoor transmission wiring F1, F2 disconnection, short circuit or wrong wiring■ Outdoor unit power supply is OFF■ System address doesn't match■ Defect of indoor unit PC board■ Defect of outdoor unit PC board

Troubleshooting



Caution Be sure to turn off power switch before connect or disconnect connector, or parts damage may be occurred.

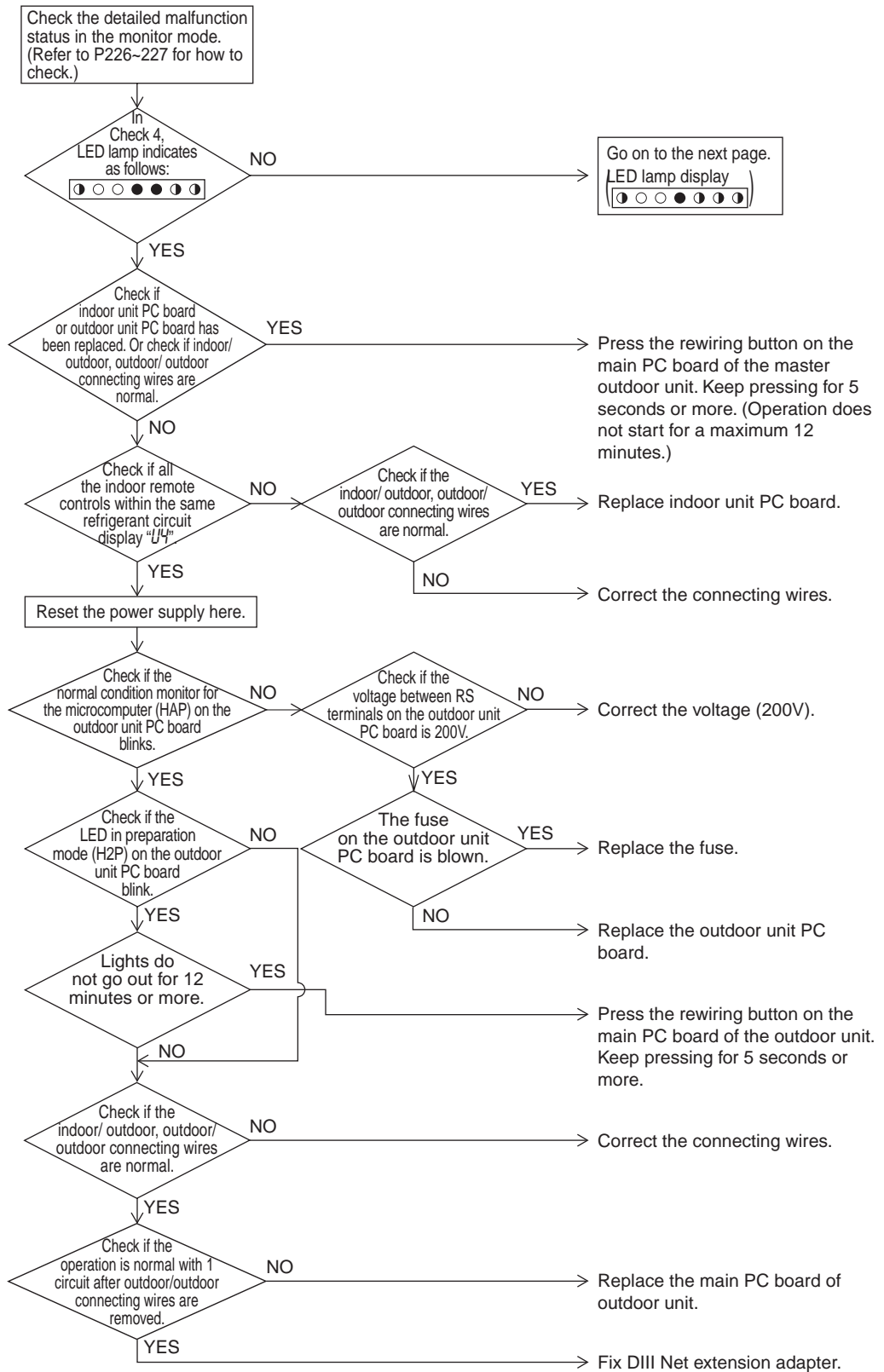

Troubleshooting



Caution

Be sure to turn off power switch before connect or disconnect connector, or parts damage may be occurred.

Continued from the previous page
 In Check 4, LED lamp indicates as follows:
 (● ○ ○ ● ● ● ●)

Start operation of all the indoor units.

Check if all the units indicate "U9".

NO

Continue operation.

YES

Check if more than 2 minutes passed since "U9" was indicated.

NO

Make a diagnosis again based on the indication in 2 minutes and over.

YES

The indoor units PC board indicating "U9" are normal. Check the indoor units in the other circuits to diagnose failure according to the corresponding malfunction codes.

3.49 "U5" Indoor Unit: Malfunction of Transmission between Remote Control and Indoor Unit

Remote Control Display	U5
Applicable Models	All models of indoor units
Method of Malfunction Detection	In case of controlling with 2-remote control, check the system using microcomputer is signal transmission between indoor unit and remote control (main and sub) is normal.
Malfunction Decision Conditions	Normal transmission does not continue for specified period.
Supposed Causes	<ul style="list-style-type: none"> ■ Malfunction of indoor unit remote control transmission ■ Connection of two main remote controls (when using 2 remote controls) ■ Defect of indoor unit PC board ■ Defect of remote control PC board ■ Malfunction of transmission caused by noise

Troubleshooting

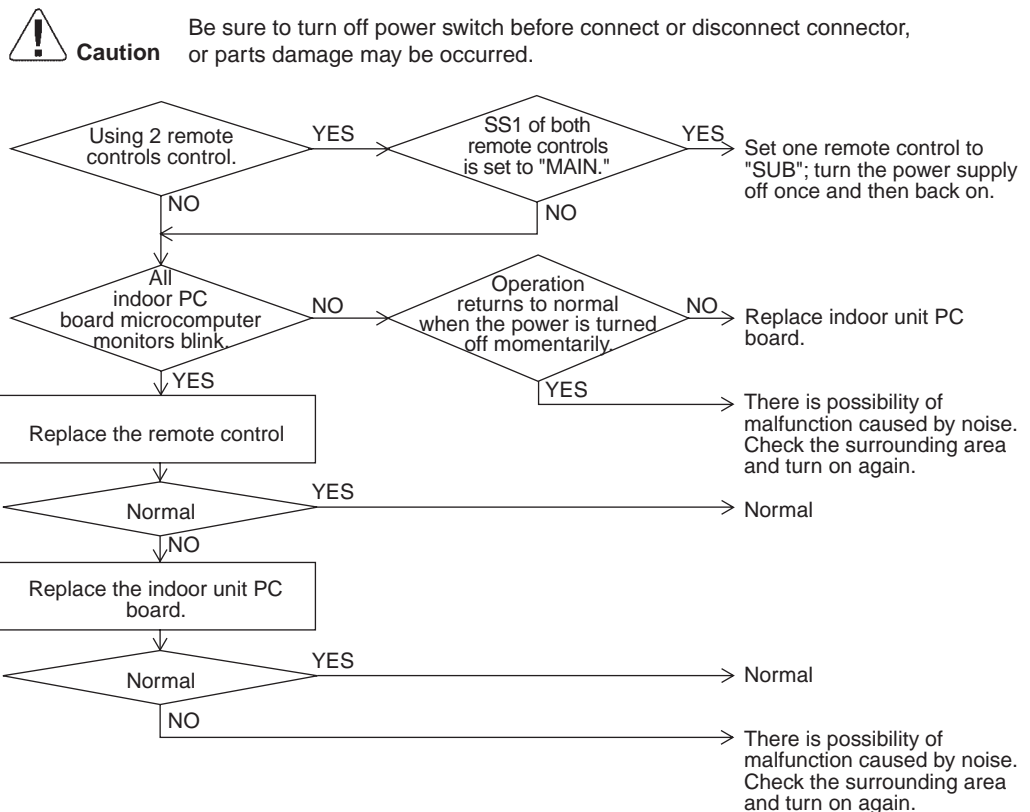

(V2823)

3.50 “U7” Outdoor Unit: Transmission Failure (Across Outdoor Units)

Remote Control Display	U7
Applicable Models	All models of outdoor units
Method of Malfunction Detection	Microcomputer checks if transmission between outdoor units.
Malfunction Decision Conditions	When transmission is not carried out normally for a certain amount of time
Supposed Causes	<ul style="list-style-type: none"> ■ Connection error in connecting wires between outdoor unit and outdoor unit outside control adapter ■ Connection error in connecting wires across outdoor units ■ Setting error in switching cooling/ heating ■ Integrated address setting error for cooling/ heating (function unit, outdoor unit outside control adapter) ■ Defective outdoor unit PC board (A1P or A3P) ■ Defective outdoor unit outside control adapter

Troubleshooting

 **Caution** Be sure to turn off power switch before connect or disconnect connector, or parts damage may be occurred.

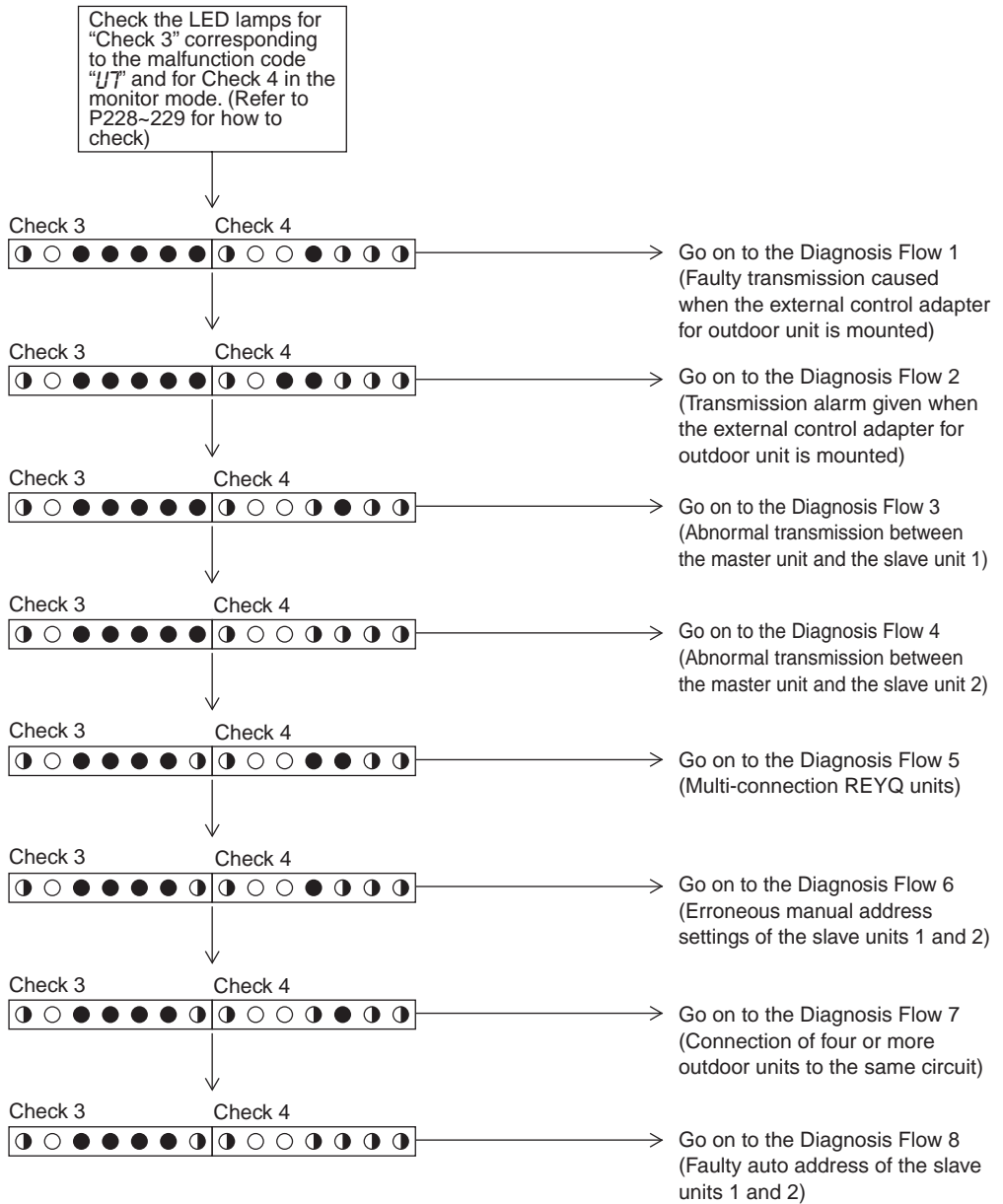

Troubleshooting

 **Caution** Be sure to turn off power switch before connect or disconnect connector, or parts damage may be occurred.

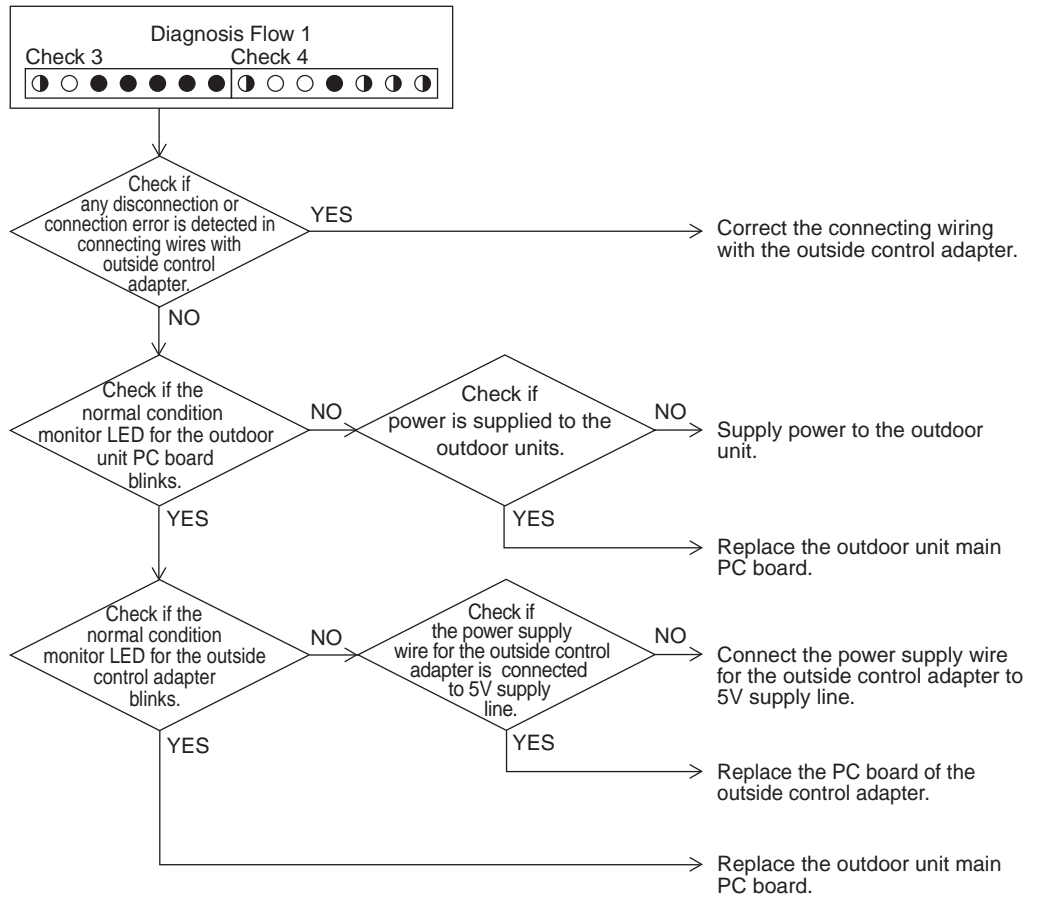

Troubleshooting



Caution Be sure to turn off power switch before connect or disconnect connector, or parts damage may be occurred.

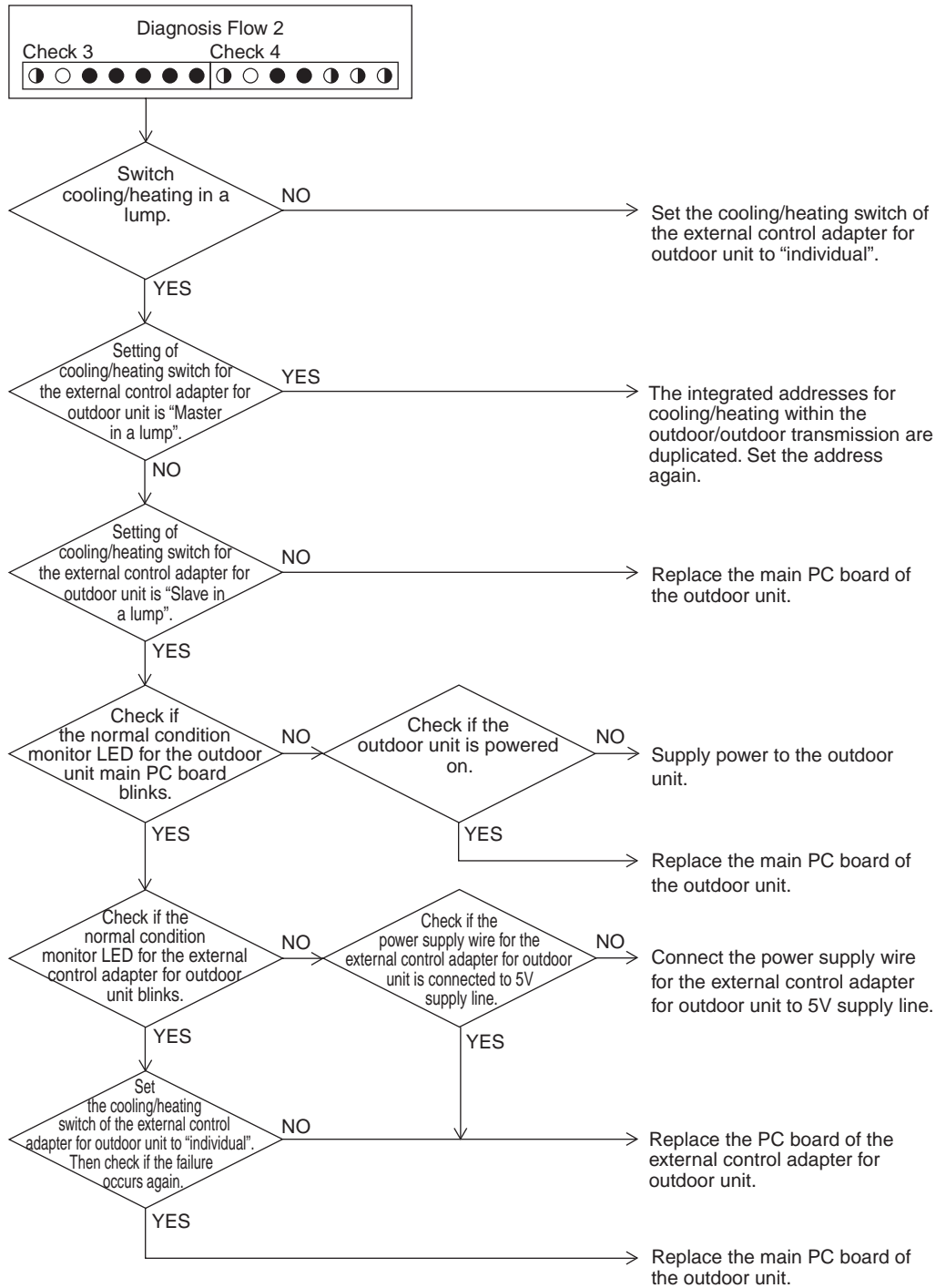

Troubleshooting

 **Caution** Be sure to turn off power switch before connect or disconnect connector, or parts damage may be occurred.

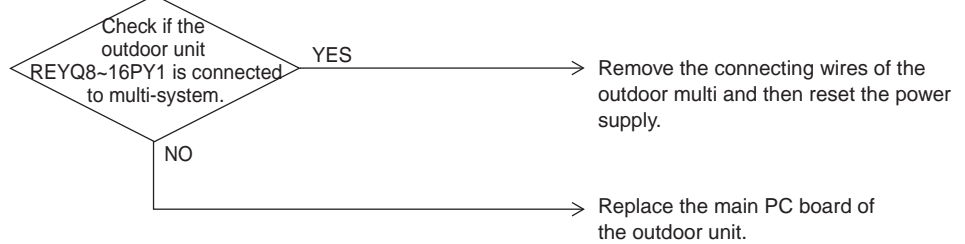
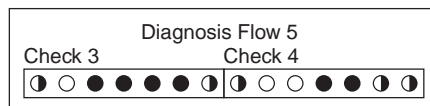
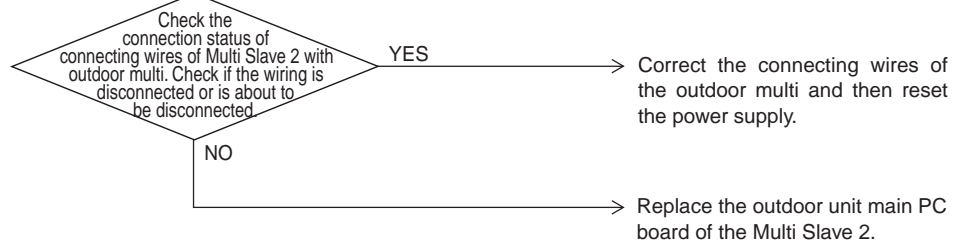
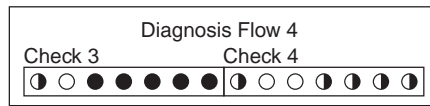
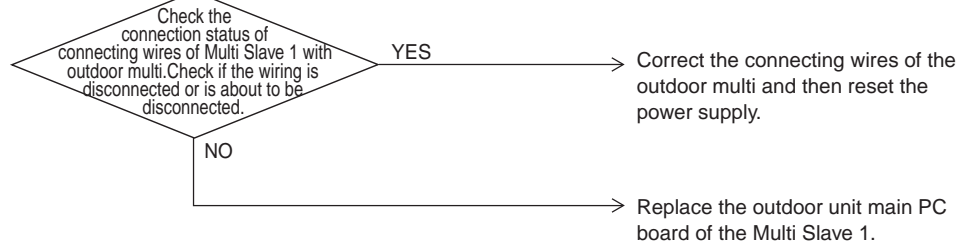
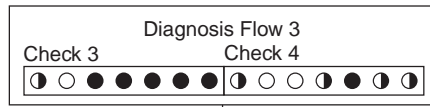

Troubleshooting



Caution

Be sure to turn off power switch before connect or disconnect connector, or parts damage may be occurred.

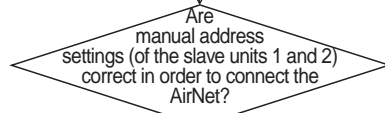
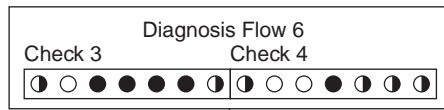

NO

Correct the manual address settings.
(For detail, refer to information in the "AirNet Installation Manual".)

YES

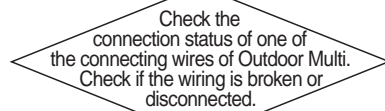

YES

Correct the connecting wires of the outdoor multi and then reset the power supply.

NO

Replace the main PC board of the outdoor unit.

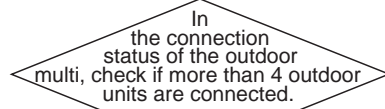
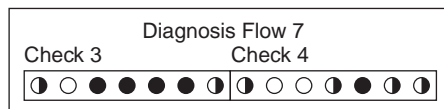

YES

Correct the connecting wires of the outdoor multi and then reset the power supply.

NO

Replace the main PC board of the outdoor unit.

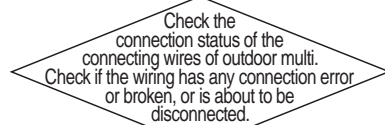
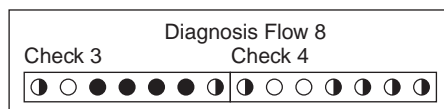

YES

Correct the connecting wires of the outdoor multi and then reset the power supply.

NO

Replace the main PC board of the outdoor unit.

3.51 “UB” Indoor Unit: Malfunction of Transmission between Main and Sub Remote Controls

Remote Control Display	UB
Applicable Models	All models of indoor units
Method of Malfunction Detection	In case of controlling with 2-remote control, check the system using microcomputer if signal transmission between indoor unit and remote control (main and sub) is normal.
Malfunction Decision Conditions	Normal transmission does not continue for specified period.
Supposed Causes	<ul style="list-style-type: none"> ■ Malfunction of transmission between main and sub remote control ■ Connection between sub remote controls ■ Defect of remote control PC board

Troubleshooting

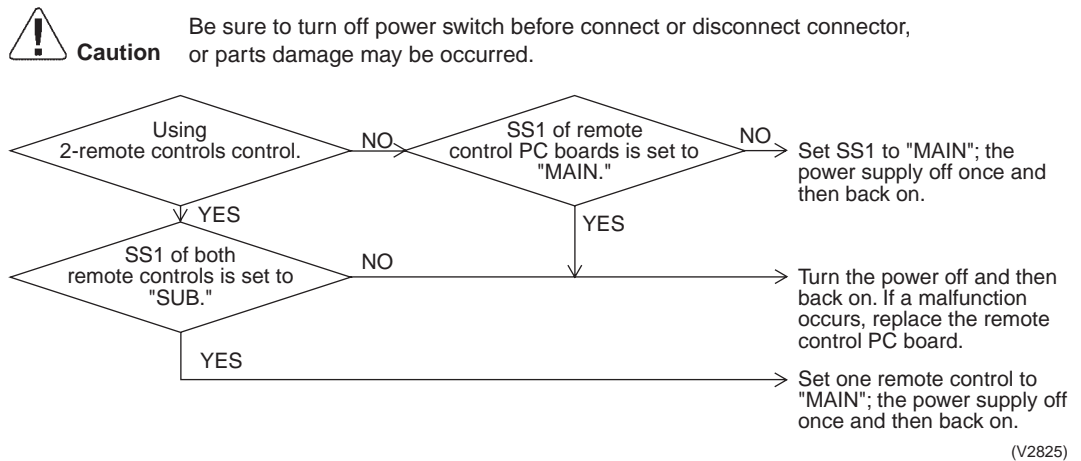

3.52 “U9” Indoor Unit: Malfunction of Transmission between Indoor and Outdoor Units in the Same System

Remote Control Display	U9
Applicable Models	All models of indoor units REYQ8P~48P
Method of Malfunction Detection	Detect malfunction signal for the other indoor units within the circuit by outdoor unit PC board.
Malfunction Decision Conditions	When the malfunction decision is made on any other indoor unit within the system concerned.
Supposed Causes	<ul style="list-style-type: none"> ■ Malfunction of transmission within or outside of other system ■ Malfunction of electronic expansion valve in indoor unit of other system ■ Defect of PC board of indoor unit in other system ■ Improper connection of transmission wiring between indoor and outdoor unit

Troubleshooting

 **Caution** Be sure to turn off power switch before connect or disconnect connector, or parts damage may be occurred.

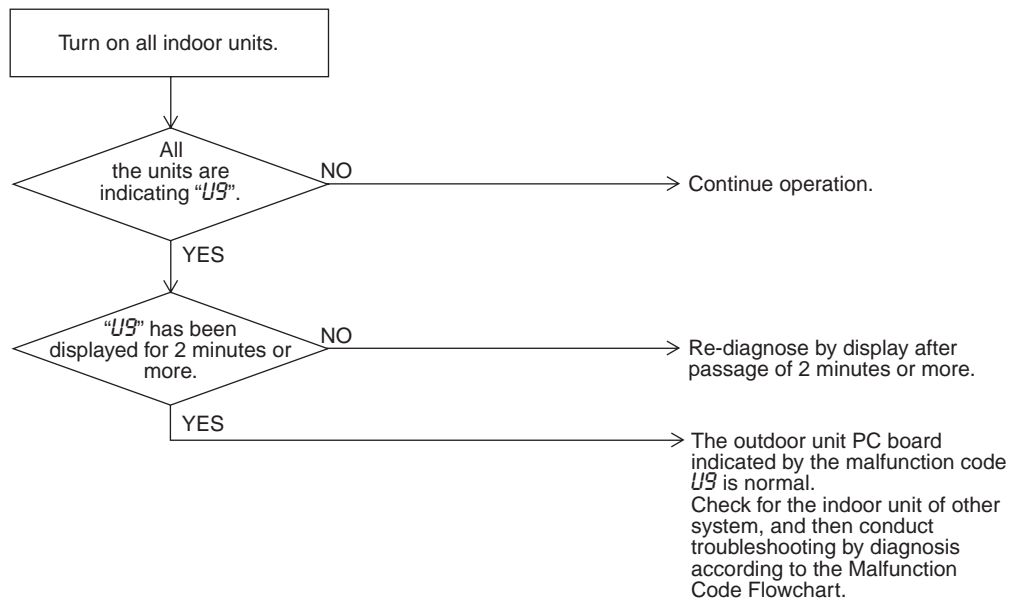

3.53 “UR” Improper Combination of Indoor and Outdoor Units, Indoor Units and Remote Control

Remote Control Display	<i>UR</i>
Applicable Models	All models of indoor unit REYQ8P~48P
Method of Malfunction Detection	A difference occurs in data by the type of refrigerant between indoor and outdoor units. The number of indoor units is out of the allowable range. Incorrect signals are transmitted among the indoor unit, BS unit, and outdoor unit.
Malfunction Decision Conditions	The malfunction decision is made as soon as either of the abnormalities aforementioned is detected.
Supposed Causes	<ul style="list-style-type: none"> ■ Excess of connected indoor units ■ Defect of outdoor unit PC board (A1P) ■ Mismatching of the refrigerant type of indoor and outdoor unit. ■ Setting of outdoor PC board was not conducted after replacing to spare parts PC board.

Troubleshooting



Caution Be sure to turn off power switch before connect or disconnect connector, or parts damage may be occurred.

Check the LED lamps for "Check 3" corresponding to the malfunction code "UP" and for Check 4 in the monitor mode. (Refer to P228-229 for how to check.)

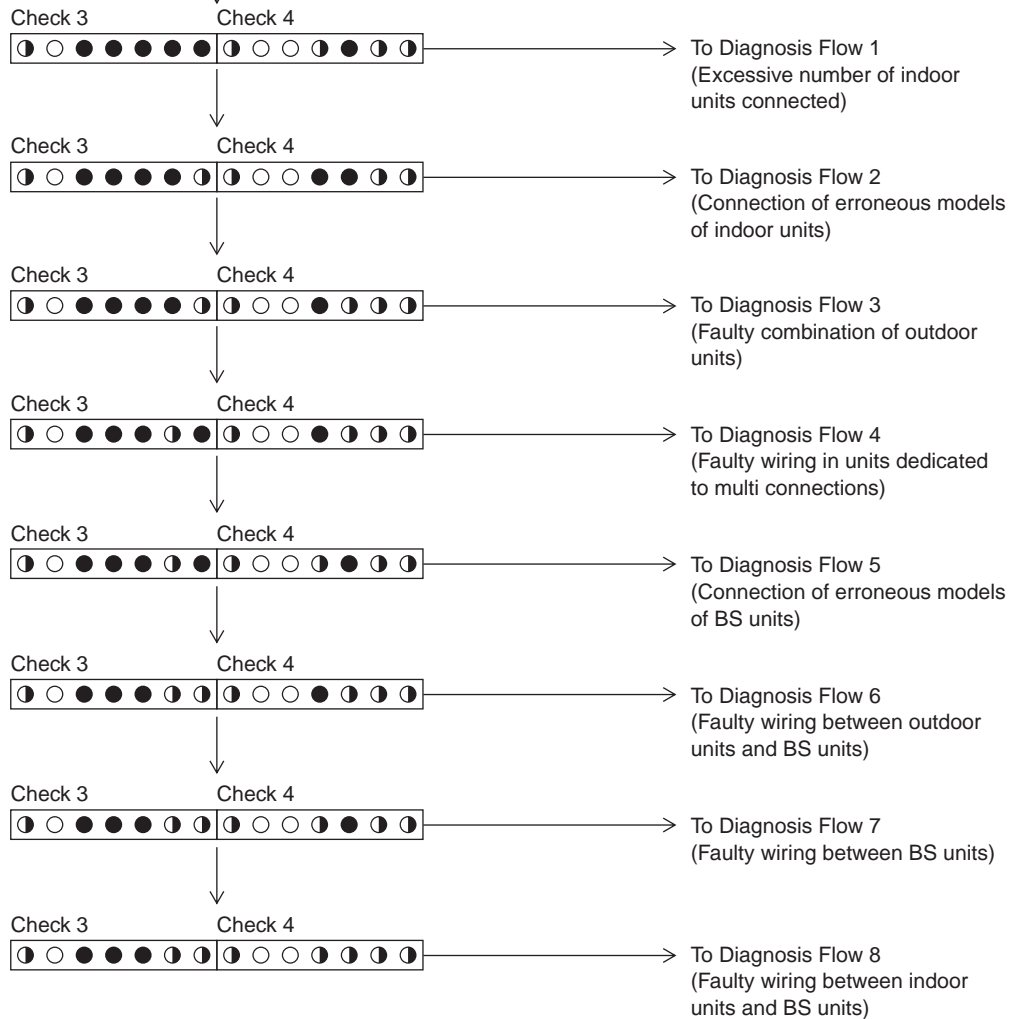

Troubleshooting



Caution

Be sure to turn off power switch before connect or disconnect connector, or parts damage may be occurred.

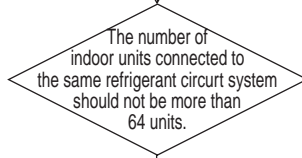
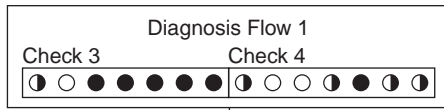

YES

Replace the main PC board of the outdoor unit.

- With single systems, replace the control PC board 1 (A1P) or the control PC board 3 (A3P).
- With multi systems, replace the main PC board (A1P).

NO

The number of indoor units exceeds the standard. Check the connection to correct.

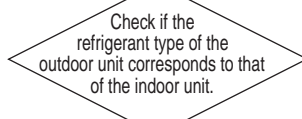
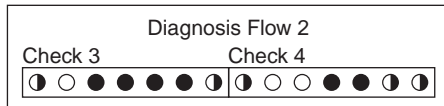

YES

Replace the main PC board of the outdoor unit.

- With single systems, replace the control PC board 1 (A1P).
- With multi systems, replace the main PC board (A1P).

NO

Match the refrigerant types of the outdoor unit and the indoor unit.

Troubleshooting



Caution Be sure to turn off power switch before connect or disconnect connector, or parts damage may be occurred.

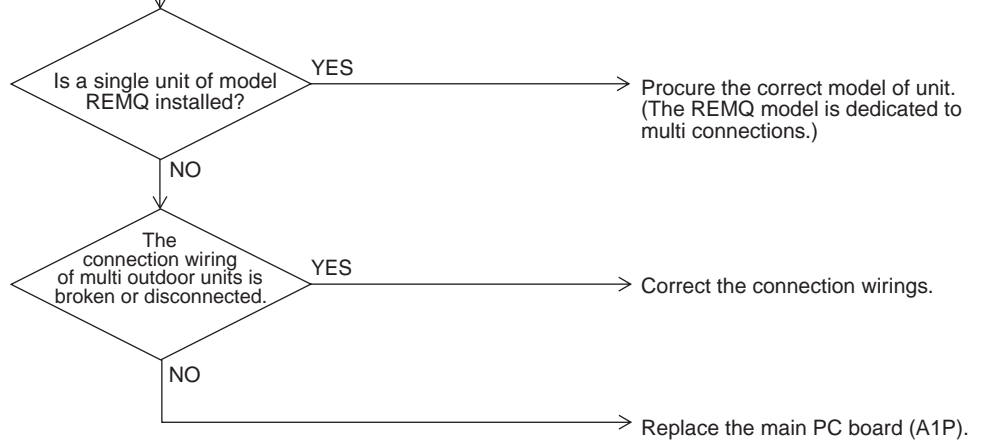
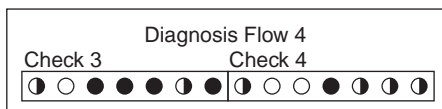
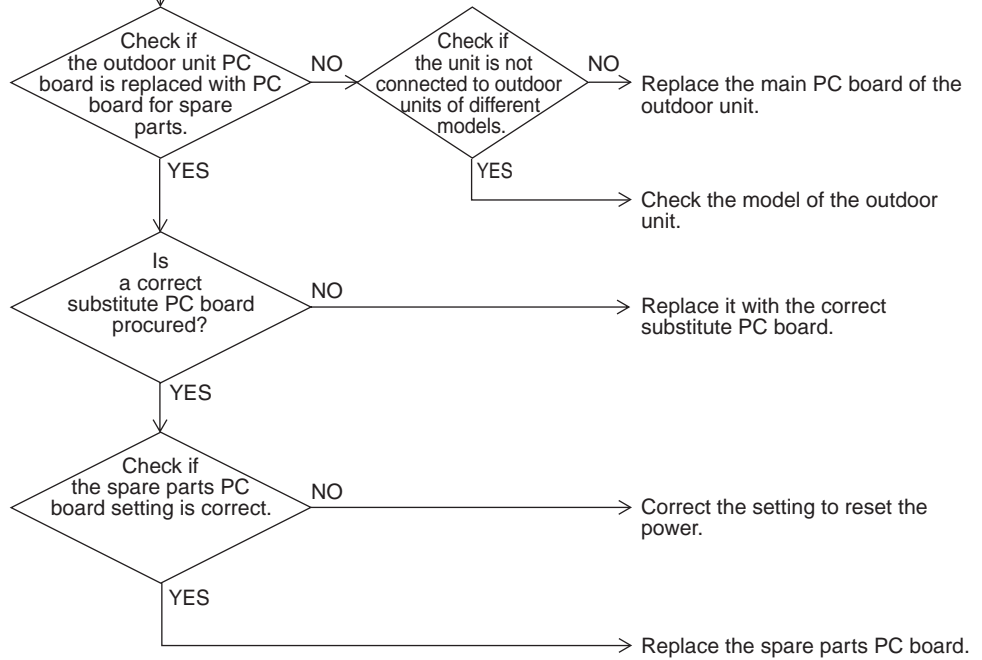
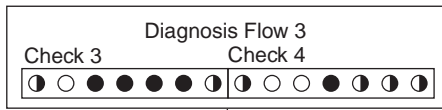

Troubleshooting



Caution

Be sure to turn off power switch before connect or disconnect connector, or parts damage may be occurred.

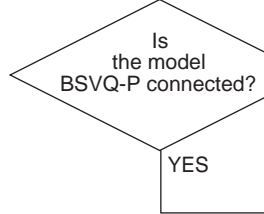
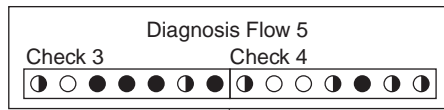

- Connect the model BSVQ-P.
- Replace the outdoor unit PC board as shown below.
 - With single systems, replace the control PC board 1 (A1P).
 - With multi systems, replace the main PC board (A1P).

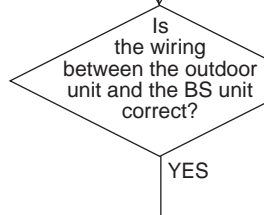
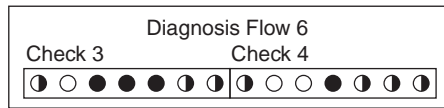

- Correct the wiring.
- Replace the outdoor unit PC board as shown below.
 - With single systems, replace the control PC board 1 (A1P).
 - With multi systems, replace the main PC board (A1P).

Troubleshooting



Caution

Be sure to turn off power switch before connect or disconnect connector, or parts damage may be occurred.

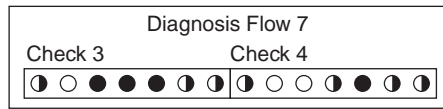

Is the wiring between the BS units correct?

NO

→ Correct the connection wiring.

YES

→ Replace the BS unit PC board concerned.

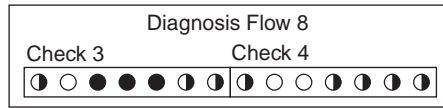

Is the connection wiring between the indoor unit and the BS unit correct?

NO

→ Correct the connection wiring.

YES

→ Replace the indoor unit or BS unit PC board.

3.54 “UC” Address Duplication of Centralized Controller

Remote Control Display	UC
Applicable Models	All models of indoor unit Centralized controller
Method of Malfunction Detection	The principal indoor unit detects the same address as that of its own on any other indoor unit.
Malfunction Decision Conditions	The malfunction decision is made as soon as the abnormality aforementioned is detected.
Supposed Causes	<ul style="list-style-type: none"> ■ Address duplication of centralized controller
Troubleshooting	<div style="display: flex; align-items: center;"> <div style="text-align: center; margin-right: 10px;">  <p>Caution</p> </div> <div style="margin-right: 20px;"> <p>Be sure to turn off power switch before connect or disconnect connector, or parts damage may be occurred.</p> </div> <div style="border: 1px solid black; padding: 5px; width: fit-content;"> <p>The centralized address is duplicated.</p> </div> <div style="margin-left: 20px; align-self: center;"> <p>→</p> </div> <div style="margin-left: 20px;"> <p>Make setting change so that the centralized address will not be duplicated.</p> </div> </div>

3.55 “UE” Malfunction of Transmission between Centralized Controller and Indoor Unit

Remote Control Display	<i>UE</i>
Applicable Models	All models of indoor units Intelligent Touch Controller Centralized controller Schedule timer
Method of Malfunction Detection	Microcomputer checks if transmission between indoor unit and centralized controller is normal.
Malfunction Decision Conditions	When transmission is not carried out normally for a certain amount of time
Supposed Causes	<ul style="list-style-type: none"> ■ Malfunction of transmission between optional controllers for centralized control and indoor unit ■ Connector for setting master controller is disconnected. (or disconnection of connector for independent / combined use changeover switch.) ■ Failure of PC board for central remote control ■ Defect of indoor unit PC board

Troubleshooting



Caution Be sure to turn off power switch before connect or disconnect connector, or parts damage may be occurred.

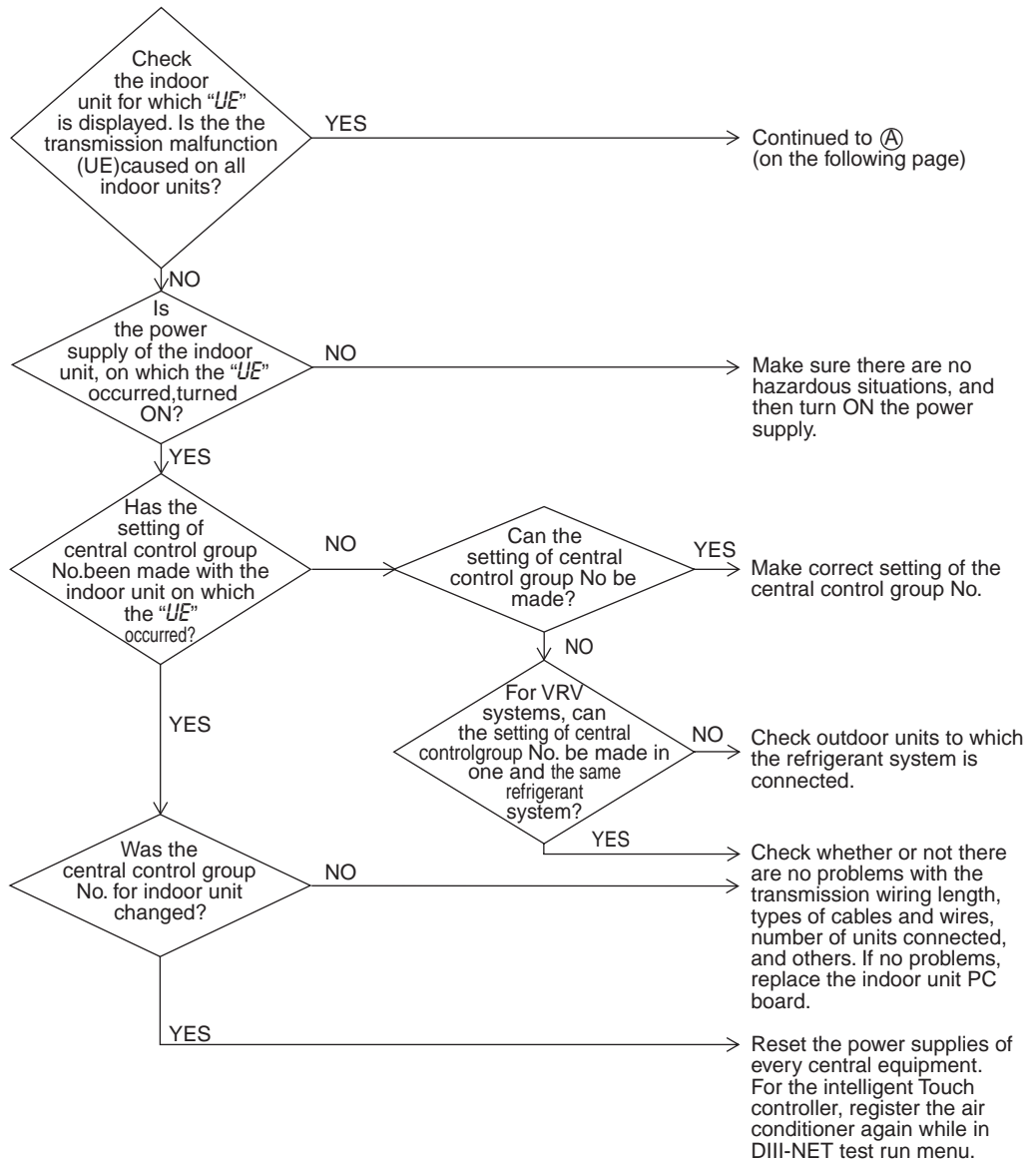

(V2822)

Troubleshooting

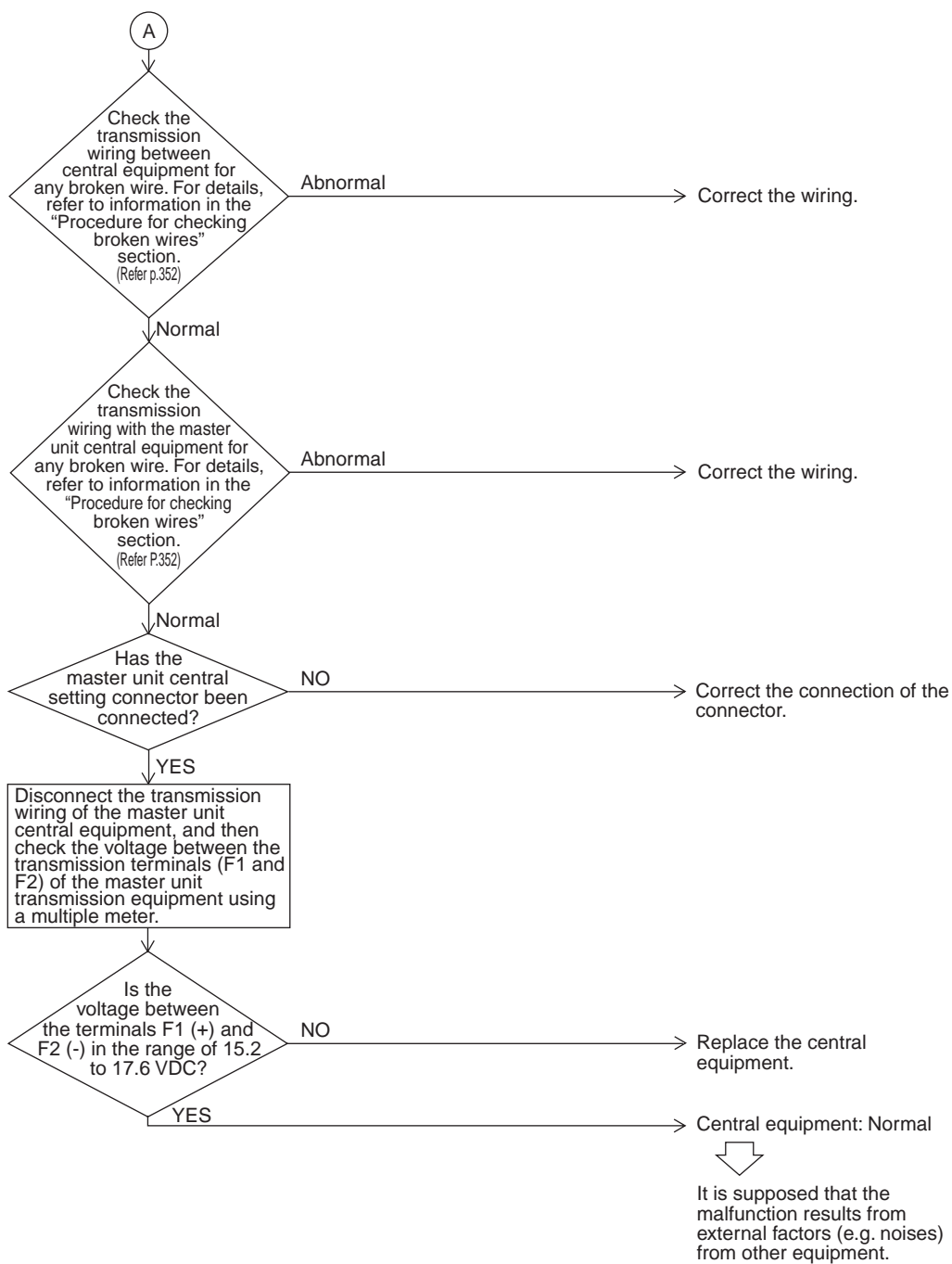

3.56 “UF” System is not Set yet

Remote Control Display	UF
Applicable Models	All models of indoor units REYQ8P~48P
Method of Malfunction Detection	On check operation, the number of indoor units in terms of transmission is not corresponding to that of indoor units that have made changes in temperature.
Malfunction Decision Conditions	The malfunction is determined as soon as the abnormality aforementioned is detected through checking the system for any erroneous connection of units on the check operation.
Supposed Causes	<ul style="list-style-type: none"> ■ Improper connection of transmission wiring between indoor-outdoor units and outdoor-outdoor units ■ Failure to execute check operation ■ Defect of indoor unit PC board ■ Stop valve is left in closed

Troubleshooting



Caution Be sure to turn off power switch before connect or disconnect connector, or parts damage may be occurred.

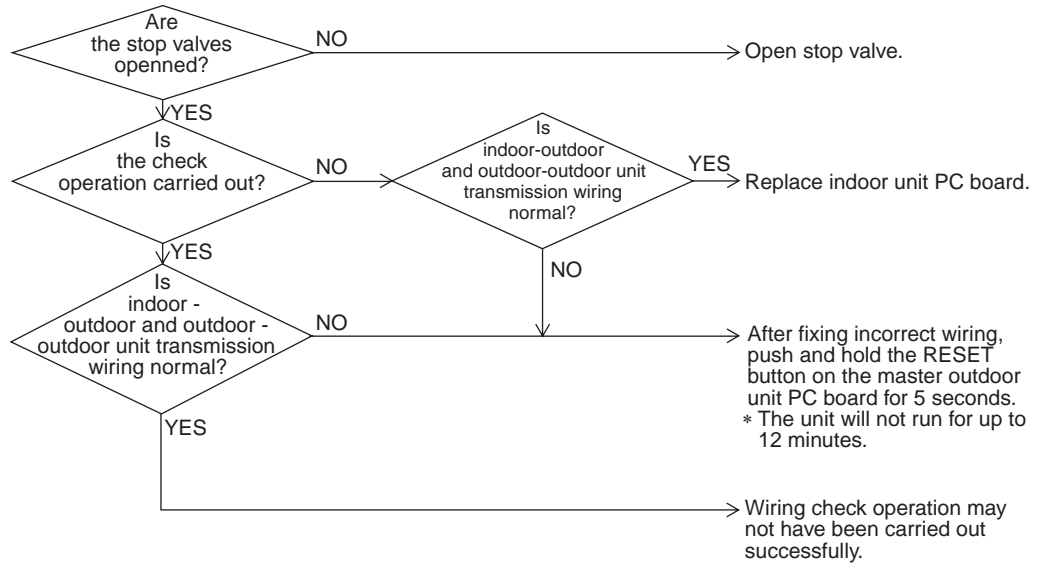

(V2830)



Note: Wiring check operation may not be successful if carried out after the outdoor unit has been off for more than 12 hours, or if it is not carried out after running all connected indoor units in the fan mode for at least an hour.

3.57 “UH” Malfunction of System, Refrigerant System Address Undefined

Remote Control Display	UH
Applicable Models	All models of indoor units REYQ8P~48P
Method of Malfunction Detection	Detect an indoor unit with no address setting.
Malfunction Decision Conditions	The malfunction decision is made as soon as the abnormality aforementioned is detected.
Supposed Causes	<ul style="list-style-type: none"> ■ Improper connection of transmission wiring between indoor-outdoor units and outdoor-outdoor units ■ Defect of indoor unit PC board ■ Defect of outdoor unit main PC board (A1P or A3P)

Troubleshooting



Caution Be sure to turn off power switch before connect or disconnect connector, or parts damage may be occurred.

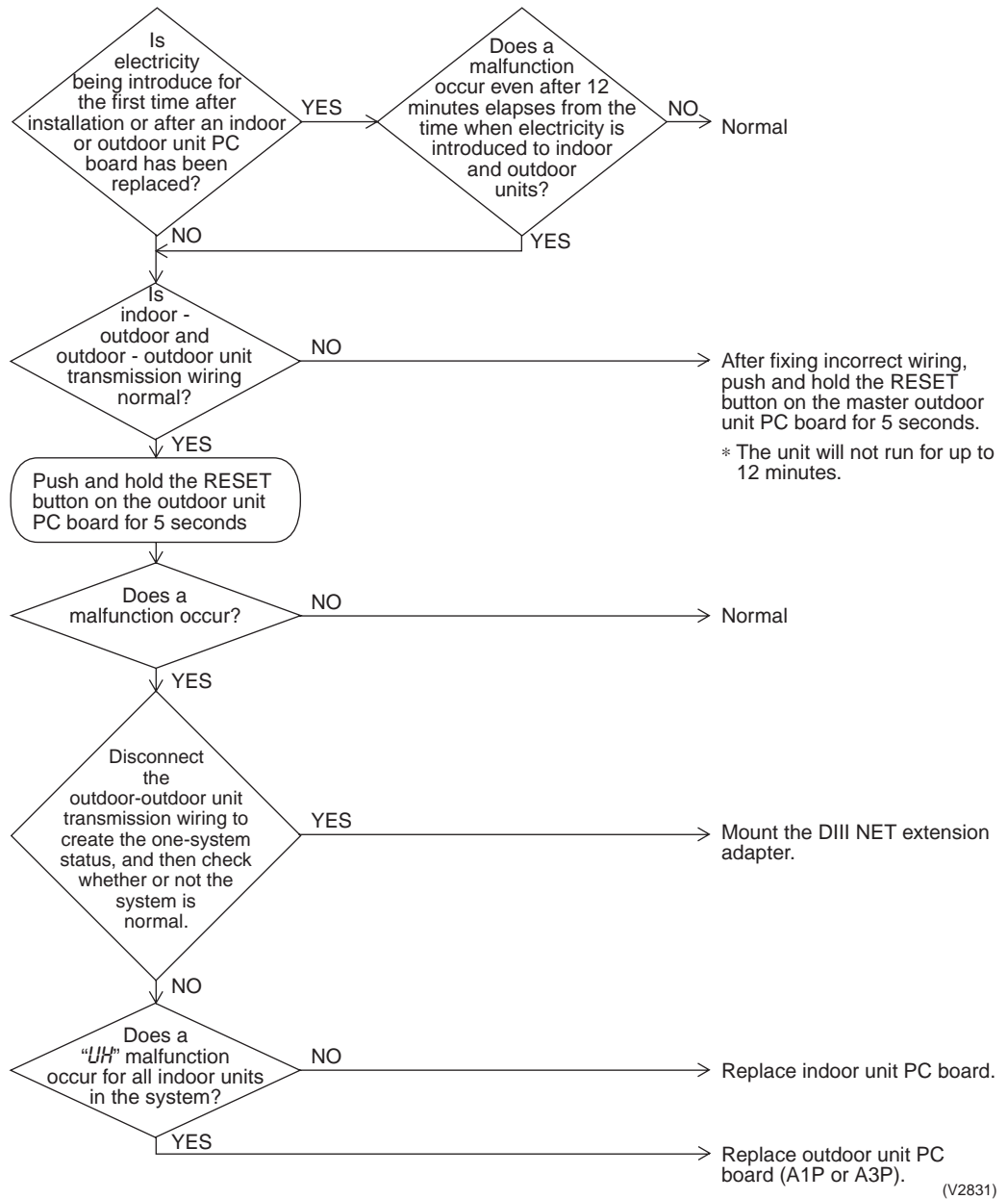

*1: Check the correct wiring "indoor-outdoor" and "outdoor-outdoor" by Installation Instruction.

*2: What is Auto Address?

This is the address automatically assigned to indoor units and outdoor units after initial power supply upon installation, or after executing rewiring (Keep pressing the **[rewiring]** button for more than 4 seconds).

(V2831)

4. Troubleshooting (OP: Central Remote Control)

4.1 “M1” PC Board Defect

Remote Control Display	M1
Applicable Models	Central remote control Intelligent Touch Controller Schedule timer
Method of Malfunction Detection	Detect an abnormality in the DIII-NET polarity circuit.
Malfunction Decision Conditions	When + polarity and - polarity are detected at the same time.
Supposed Causes	<ul style="list-style-type: none"> ■ Defect of central remote control PC board ■ Defect of Intelligent Touch Controller PC board ■ Defect of Schedule timer PC board

Troubleshooting Replace the central remote control.

 **Caution** Be sure to turn off power switch before connect or disconnect connector, or parts damage may be occurred.

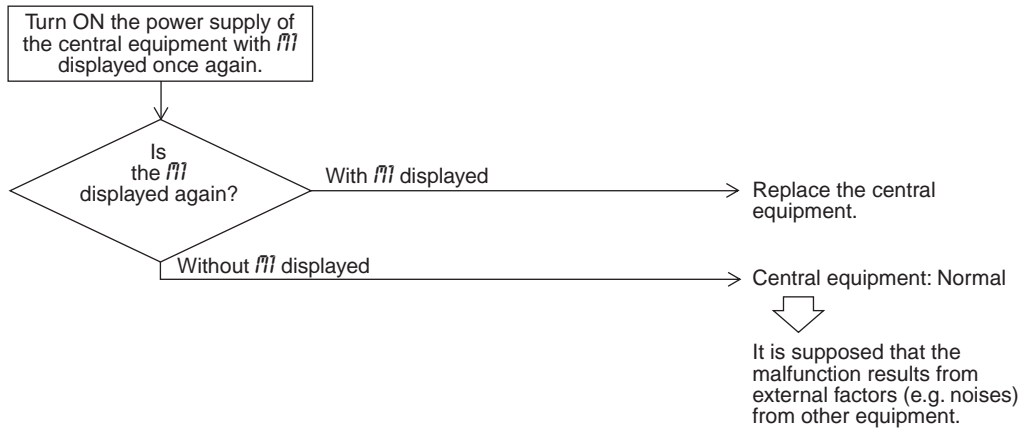

4.2 “M8” Malfunction of Transmission between Optional Controllers for Centralized Control

Remote Control Display	M8	
Applicable Models	Central remote control	Intelligent Touch Controller
Method of Malfunction Detection	Detect the malfunction according to DIII-NET transmission data. (The system will be automatically reset.)	
Malfunction Decision Conditions	When no master controller is present at the time of the startup of slave controller. When the centralized controller, which was connected once, shows no response.	
Supposed Causes	<ul style="list-style-type: none"> ■ Malfunction of transmission between optional controllers for centralized control ■ Defect of PC board of optional controllers for centralized control 	

Troubleshooting

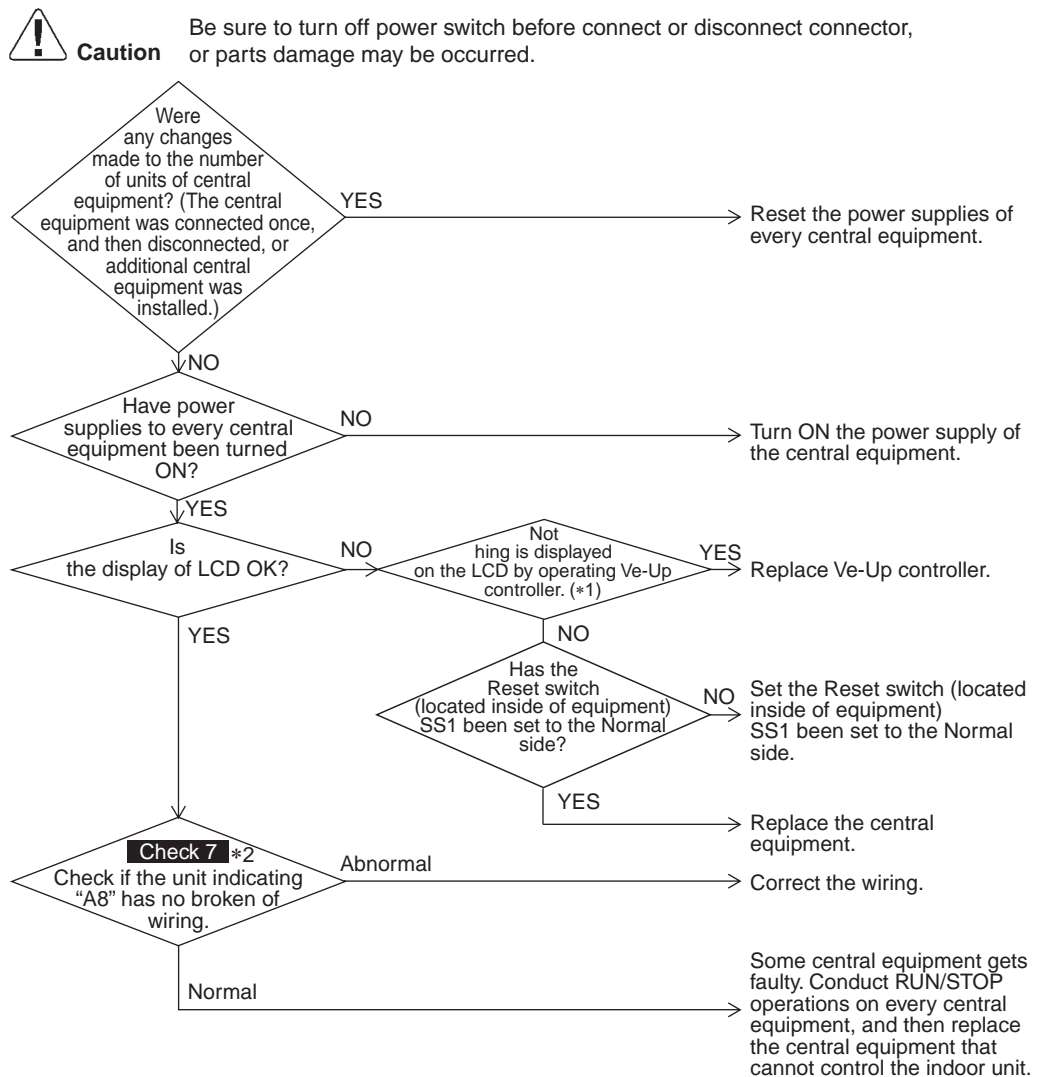

*1: Display screen control using Ve-Up controller:
When the screen displays nothing by touching the screen, adjust the contrast volume.

*2: **Check 7**: Referring to the information on P352.

4.3 “MR” Improper Combination of Optional Controllers for Centralized Control

Remote Control Display	<i>MR</i>
Applicable Models	Central remote control Intelligent touch controller Schedule timer
Method of Malfunction Detection	Detect the malfunction according to DIII-NET transmission data.
Malfunction Decision Conditions	When the schedule timer is set to individual use mode, other central component is present. When multiple master controller are present. When the remote control adapter is present.
Supposed Causes	<ul style="list-style-type: none"> ■ Improper combination of optional controllers for centralized control ■ More than one master controller is connected ■ Defect of PC board of optional controller for centralized control

Troubleshooting



Caution

Be sure to turn off power switch before connect or disconnect connector, or parts damage may be occurred.

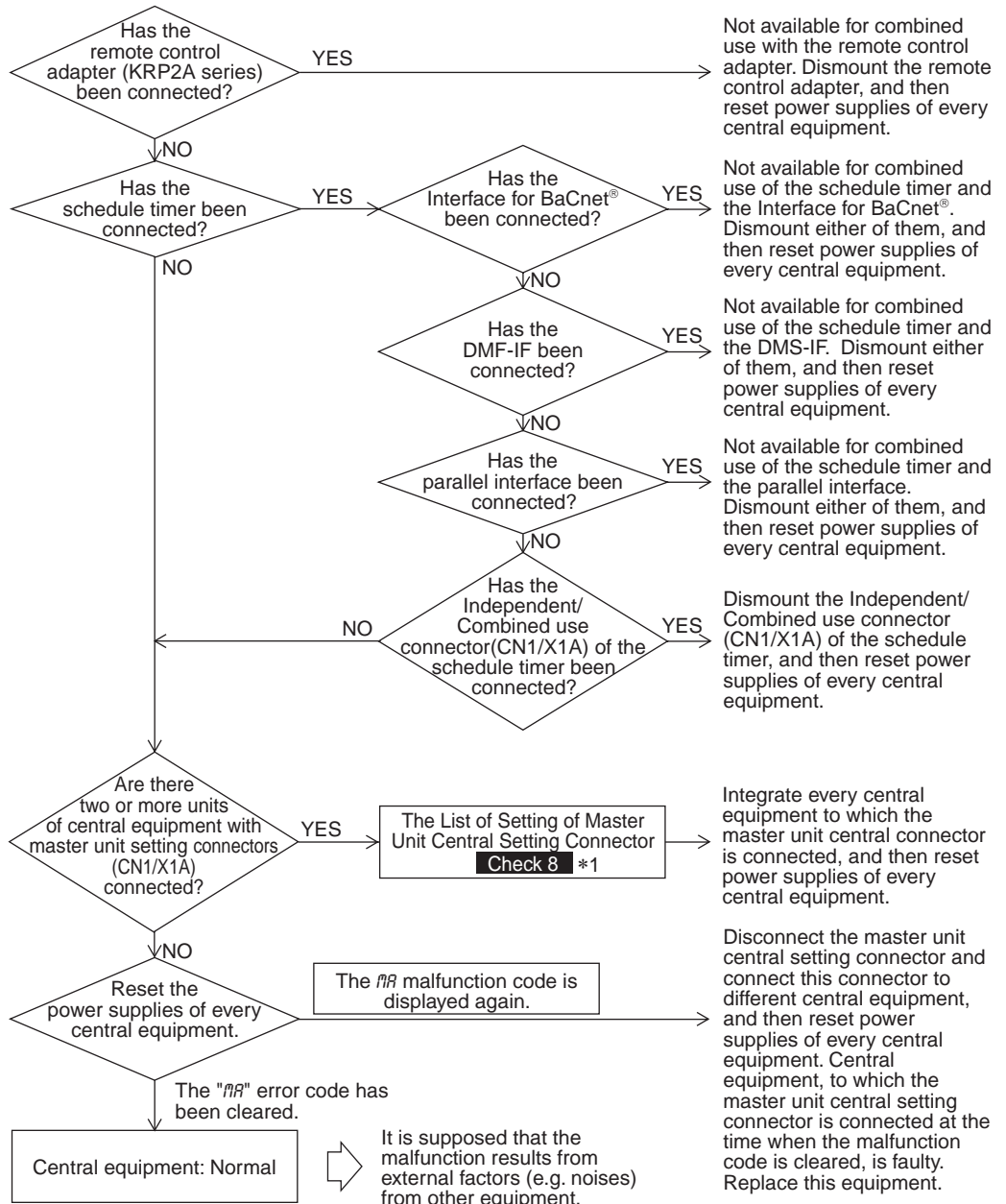

*1 **Check 8**: Referring to the information on P353.

4.4 "MC" Address Duplication, Improper Setting

Remote Control Display	MC	
Applicable Models	Central remote control	Intelligent Touch Controller
Method of Malfunction Detection	Detect the malfunction according to DIII-NET transmission data.	
Malfunction Decision Conditions	<ul style="list-style-type: none"> ■ Two or more units of central remote controls and Intelligent Touch Controllers are connected, and all of them are set to master unit central setting or slave unit central setting. ■ Two units of schedule timers are connected. 	
Supposed Causes	<ul style="list-style-type: none"> ■ Address duplication of centralized controller 	
Troubleshooting		

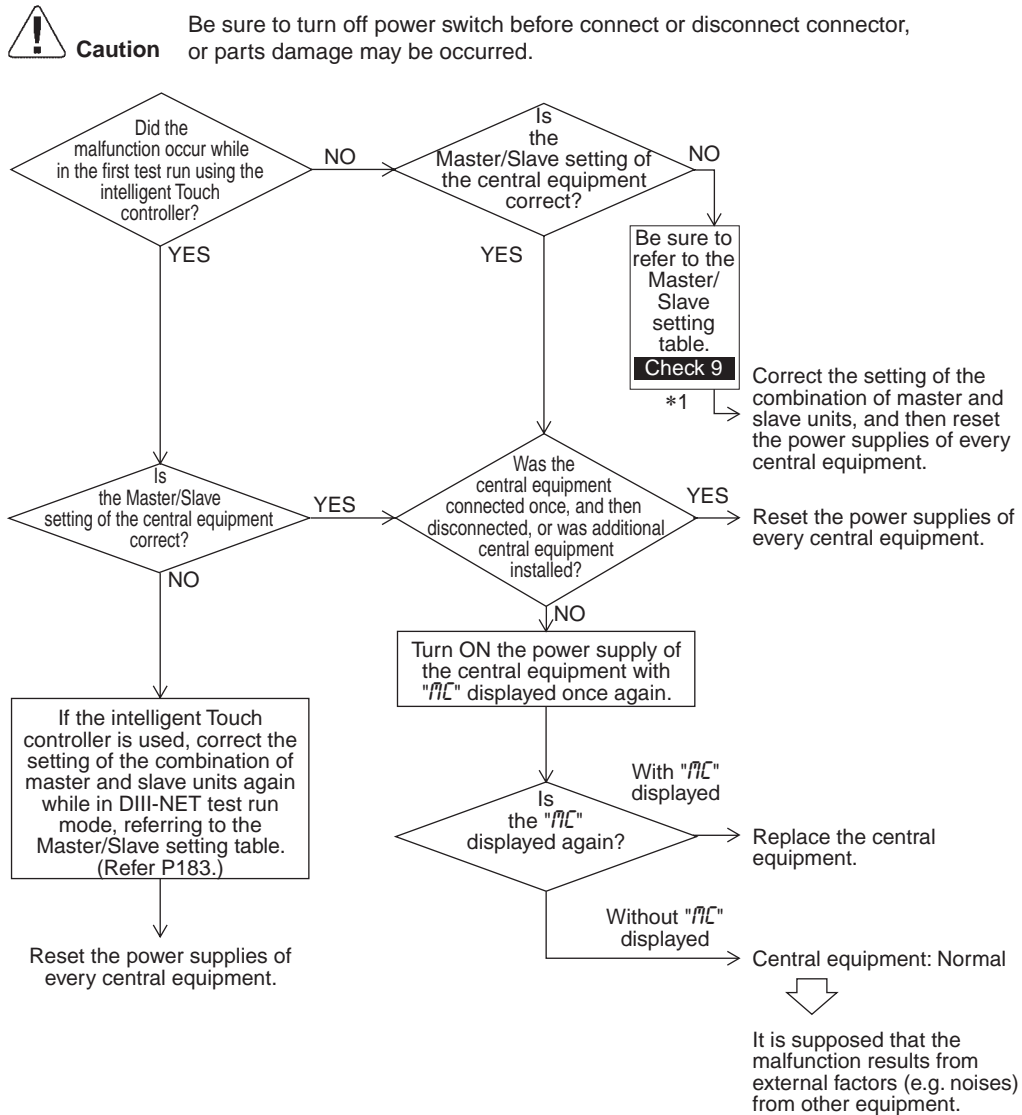

*1 **Check 9** : Referring to the information on P354.

5. Troubleshooting (OP: Unified ON/OFF Controller)

5.1 Operation Lamp Blinks

Remote Control Display

Operation lamp blinks

Applicable Models

All model of indoor units
Unified ON/OFF controller

Method of Malfunction Detection

Detect the malfunction according to DIII-NET transmission data.

Malfunction Decision Conditions**Supposed Causes**

- Malfunction of transmission between optional central controller and indoor unit
- Connector for setting master controller is disconnected
- Defect of unified ON/OFF controller PC board
- Defect of indoor unit PC board
- Malfunction of air conditioner

Troubleshooting



Caution

Be sure to turn off power switch before connect or disconnect connector, or parts damage may be occurred.

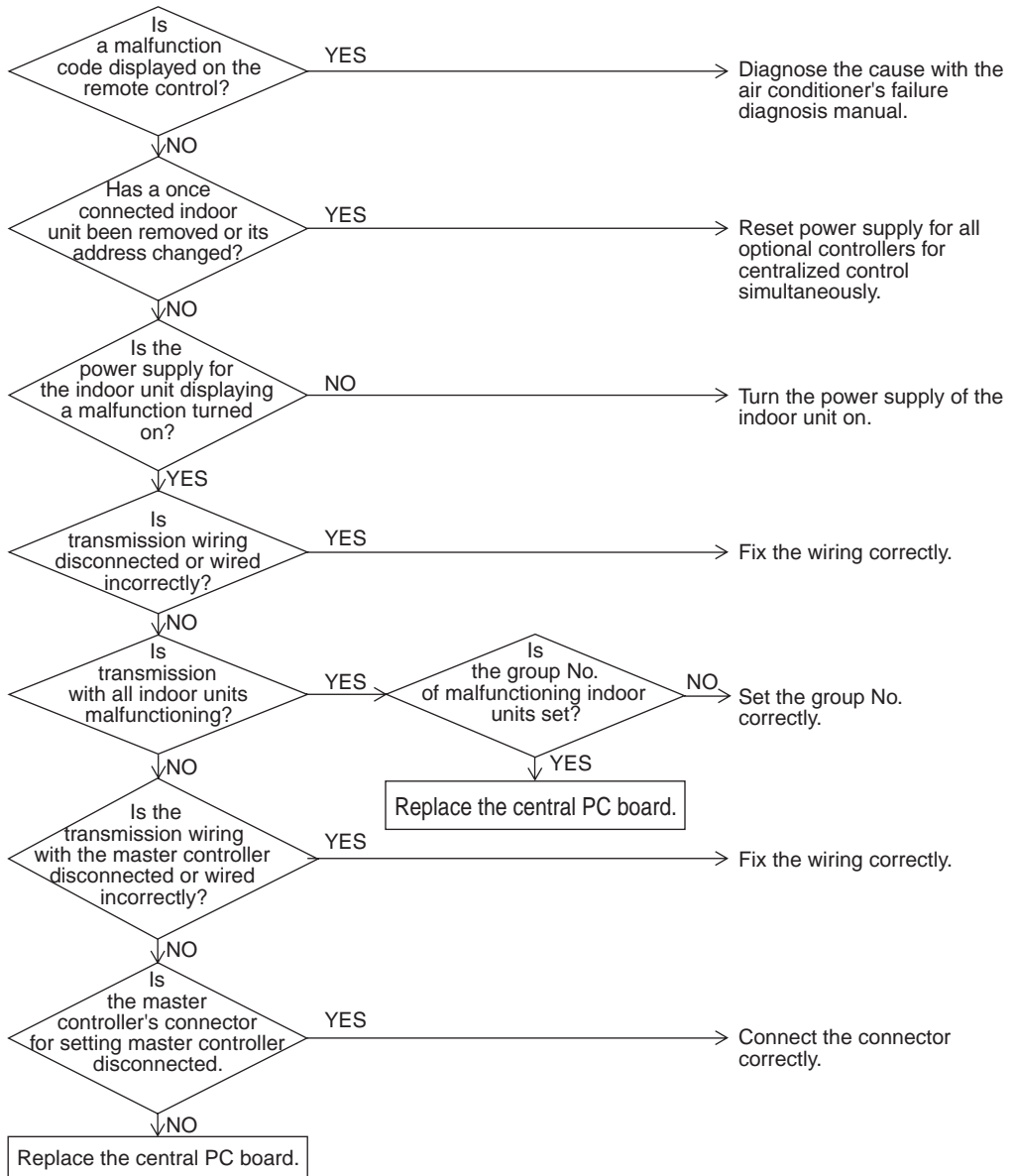

(V2841)

5.2 Display “Under Centralized Control” Blinks (Repeats Single Blink)

Remote Control Display	 “under centralized control” (Repeats single blink)
Applicable Models	Unified ON/OFF controller Central remote control, Schedule timer
Method of Malfunction Detection	Detect the malfunction according to DIII-NET transmission data.
Malfunction Decision Conditions	When the centralized controller, which was connected once, shows no response. The control ranges are overlapped. When multiple master central controller are present. When the schedule timer is set to individual use mode, other central controller is present. When the wiring adapter for electrical appendices is present.
Supposed Causes	<ul style="list-style-type: none"> ■ Address duplication of optional controllers for centralized control ■ Improper combination of optional controllers for centralized control ■ Connection of more than one master controller ■ Malfunction of transmission between optional controllers for centralized control ■ Defect of PC board of optional controllers for centralized control

Troubleshooting



Caution

Be sure to turn off power switch before connect or disconnect connector, or parts damage may be occurred.

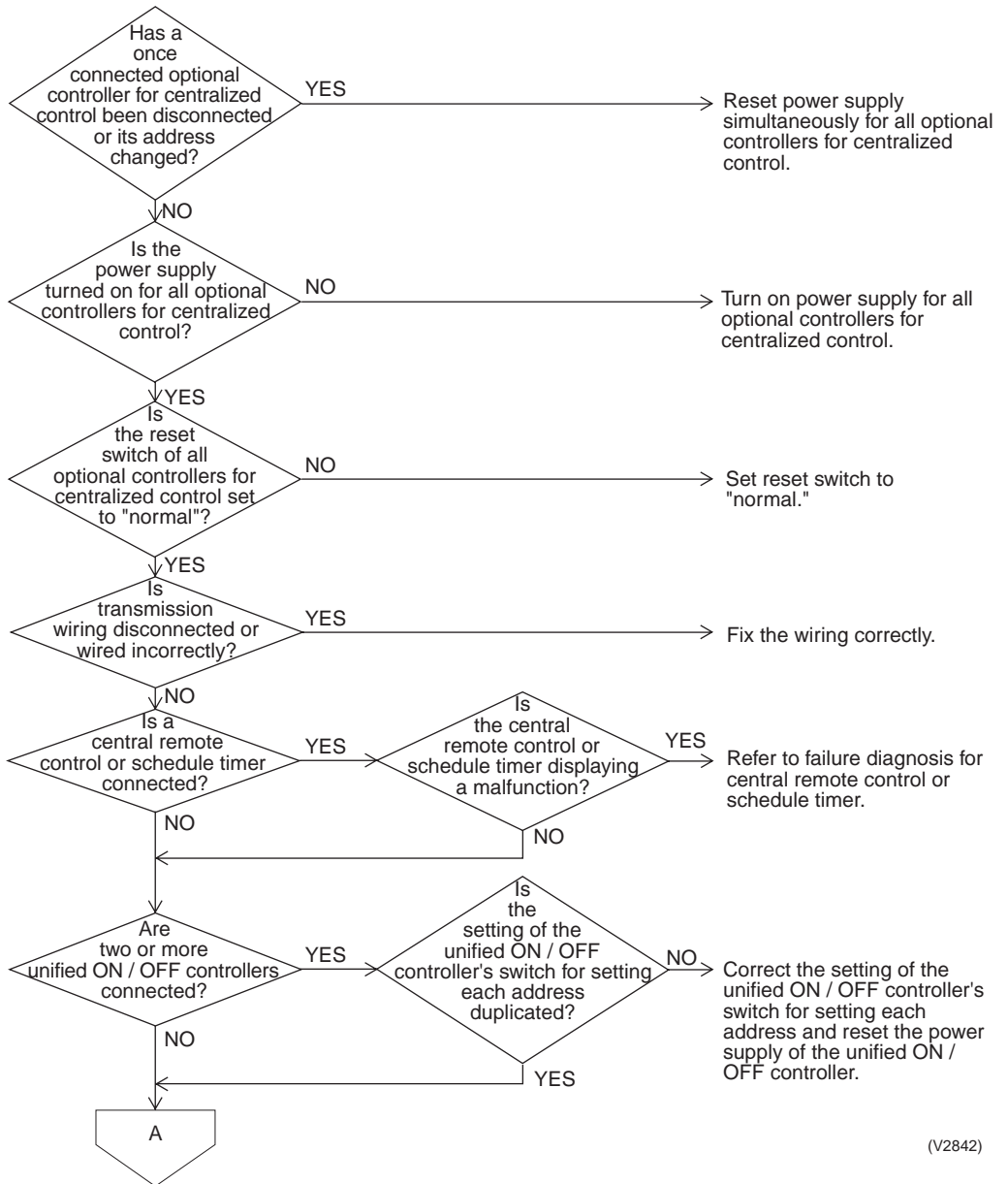

(V2842)

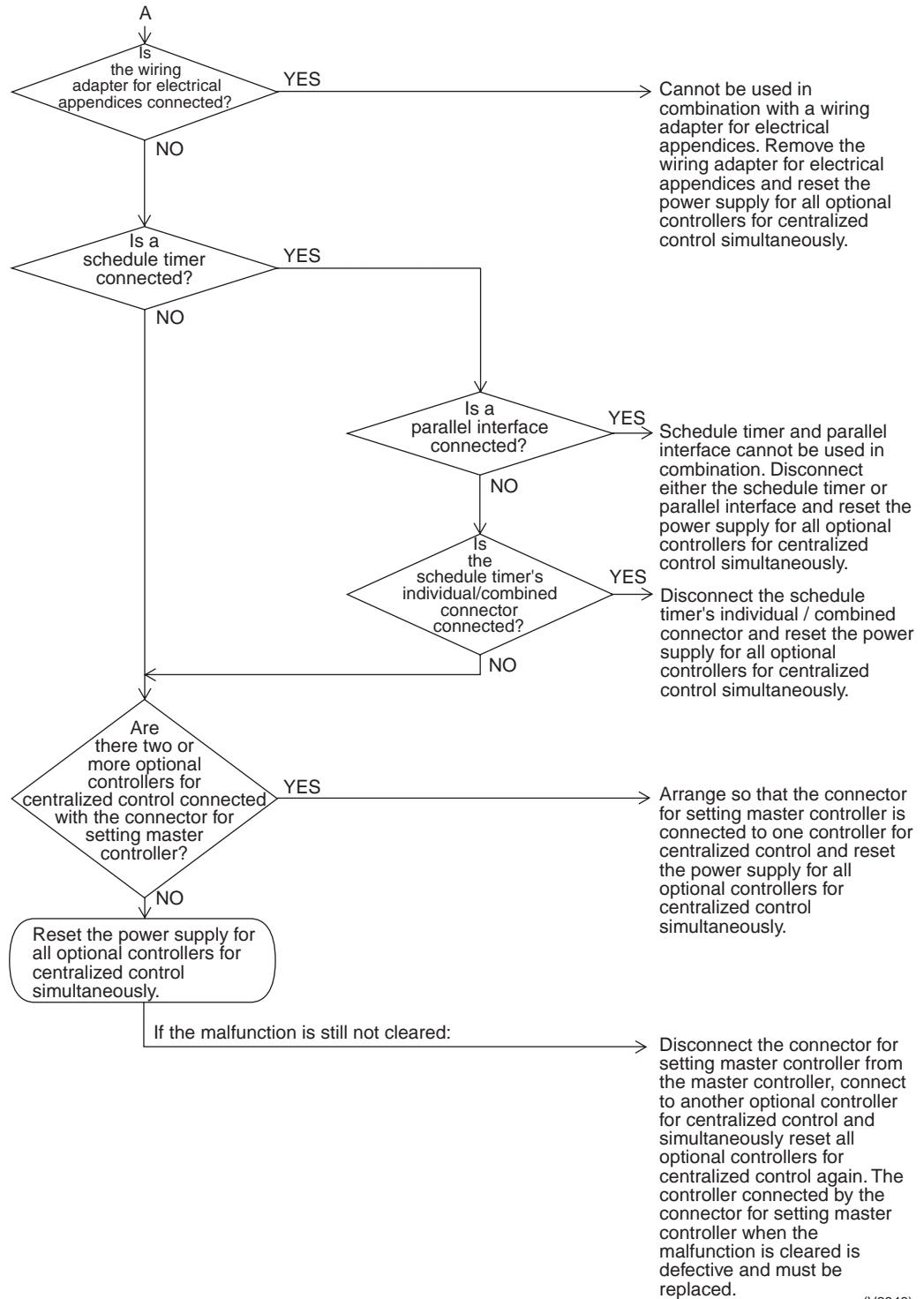

(V2843)

5.3 Display “Under Centralized Control” Blinks (Repeats Double Blink)

Remote Control Display	 “under centralized control” (Repeats double blink)
Applicable Models	Unified ON/OFF controller
Method of Malfunction Detection	Detect the malfunction according to DIII-NET transmission data.
Malfunction Decision Conditions	When no central control addresses are set to indoor units. When no indoor units are connected within the control range.
Supposed Causes	<ul style="list-style-type: none"> ■ Central control address (group No.) is not set for indoor unit. ■ Improper control range setting switch ■ Improper wiring of transmission wiring

Troubleshooting

 **Caution** Be sure to turn off power switch before connect or disconnect connector, or parts damage may be occurred.

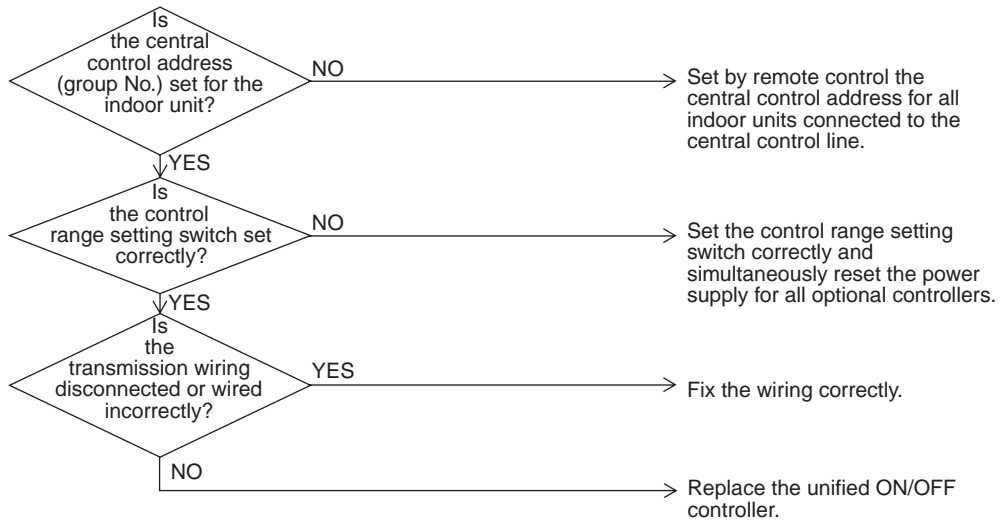

(V2844)

[CHECK 1]

Check on connector of fan motor (Power supply cable)

(1) Turn off the power supply.

Measure the resistance between phases of U,V,W at the motor side connectors (three-core wire) to check that the values are balanced and there is no short circuiting, while connector or relay connector is disconnected.

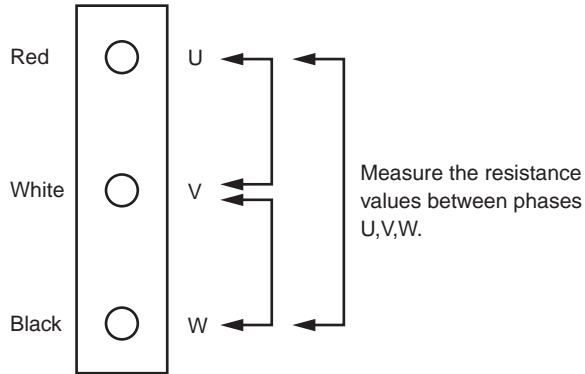

[CHECK 2]

(1) Turn off the power supply.

(2) Measure the resistance between Vcc and each phase of U,V,W, and GND and each phase at the motor side connectors (five-core wire) to check that the values are balanced within the range of $\pm 20\%$, while connector or relay connector is disconnected.

Furthermore, to use a multiple meter for measurement, connect the probe of negative pole to Vcc and that of positive pole to GND.

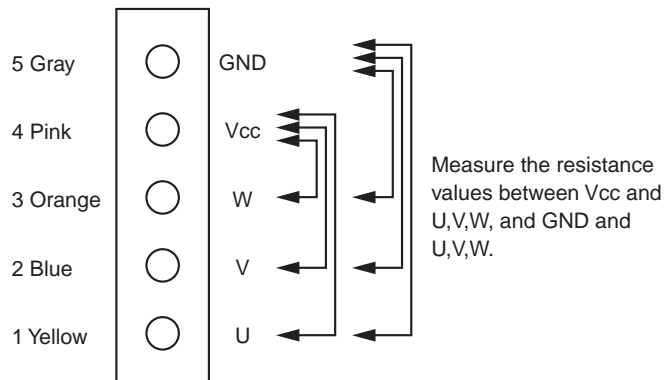

[CHECK 3] Check the Factors of Overheat Operation

Identify the defective points referring to the failure factor analysis (FTA) as follows.

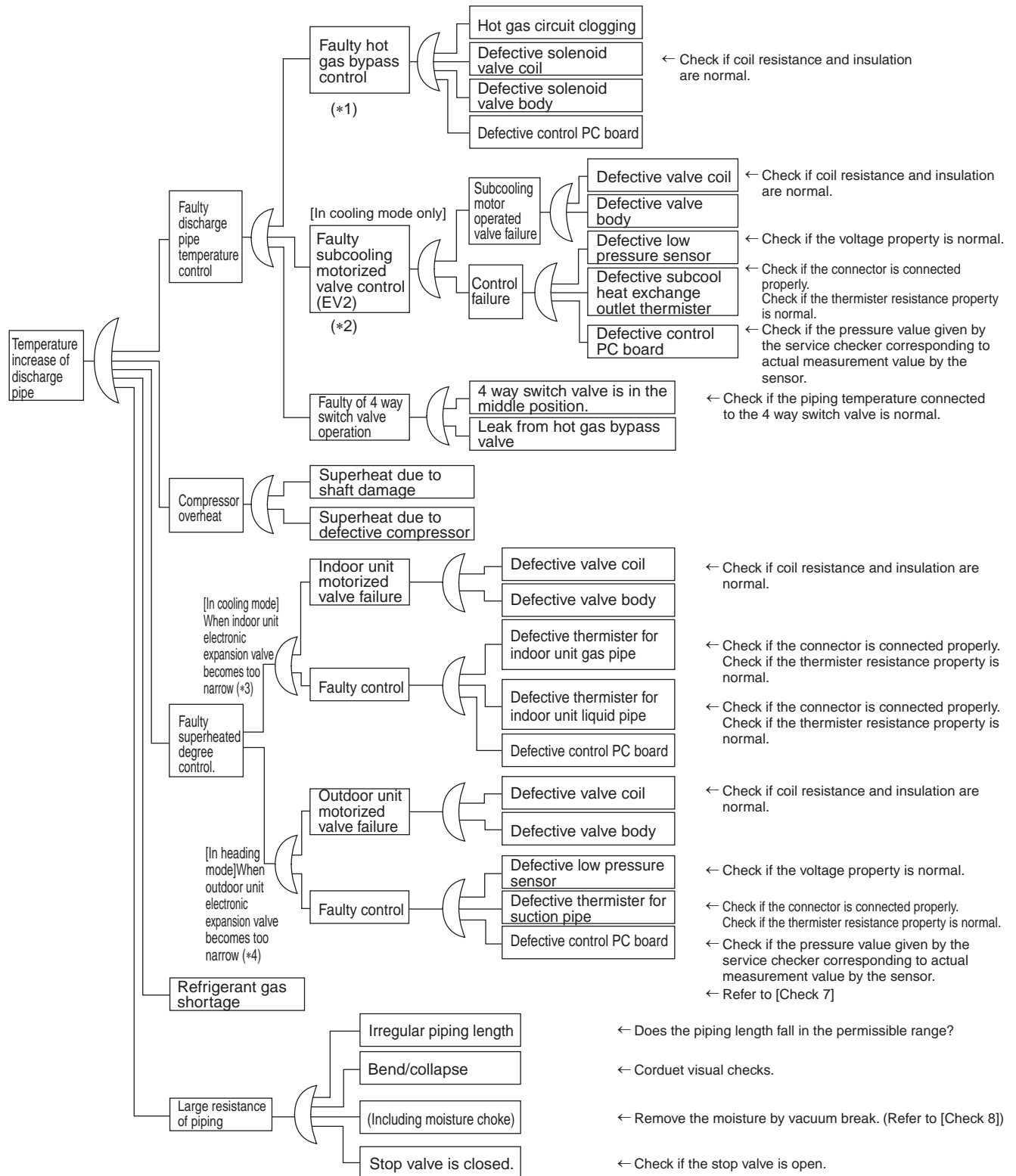

- *1: Refer to "Low pressure protective control" (P126) for hot gas bypass control.
- *2: Refer to P108 for subcooling electronic expansion valve control.
- *3: "Superheating temperature control" in cooling mode is conducted by indoor unit electronic expansion valve. (Refer to P141)
- *4: Superheating temperature control in heating mode is conducted by outdoor unit electronic expansion valve (EVM). (Refer to P108).
- *5: Judgment criteria of superheat operation:
 - ① Suction gas superheating temperature: 10 degrees and over. ② Discharge gas superheating temperature: 45 degrees and over, except for immediately after starting and drooping control, etc..
 - (Use the above stated values as a guide. Depending on the other conditions, the unit may be normal despite the values within the above scope.)

[CHECK 4] Power Transistor Check

Perform the following procedures prior to check.

- (1) Power Off.
- (2) Remove all the wiring connected to the PC board where power transistors are mounted on.

[Preparation]

· Tester

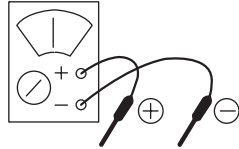

* Preparing a tester in the analog system is recommended. A tester in the digital system with diode check function will be usable.

[Point of Measurement and Judgment Criteria]

· Measure the resistance value using a tester at each point of measurement below, 10 minutes later after power OFF.

To use analog tester:

Measurement in the resistance value mode in the range of multiplying 1kΩ.

No.	Point of Measurement		Judgment Criteria	Remarks
	+	-		
1	P2	U	2 ~ 15kΩ	Due to condenser charge and so on, resistance measurement may require some time.
2	P2	V		
3	P2	W		
4	U	P2	15kΩ and above (including ∞)	
5	V	P2		
6	W	P2		
7	N3	U		
8	N3	V		
9	N3	W		
10	U	N3	2 ~ 15kΩ	
11	V	N3		
12	W	N3		

To use digital tester:

Measurement is executed in the diode check mode. (→|←)

No.	Point of Measurement		Judgment Criteria	Remarks
	+	-		
1	P2	U	1.2V and over	Due to condenser charge and so on, resistance measurement may require some time.
2	P2	V		
3	P2	W		
4	U	P2	0.3 ~ 0.7V	
5	V	P2		
6	W	P2		
7	N3	U		
8	N3	V		
9	N3	W		
10	U	N3	1.2V and over	
11	V	N3		
12	W	N3		

[PC board and Circuit Diagram]

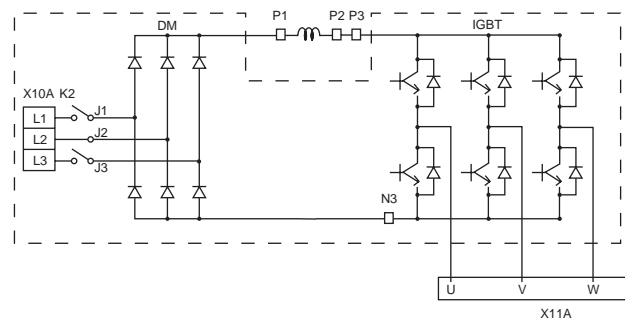
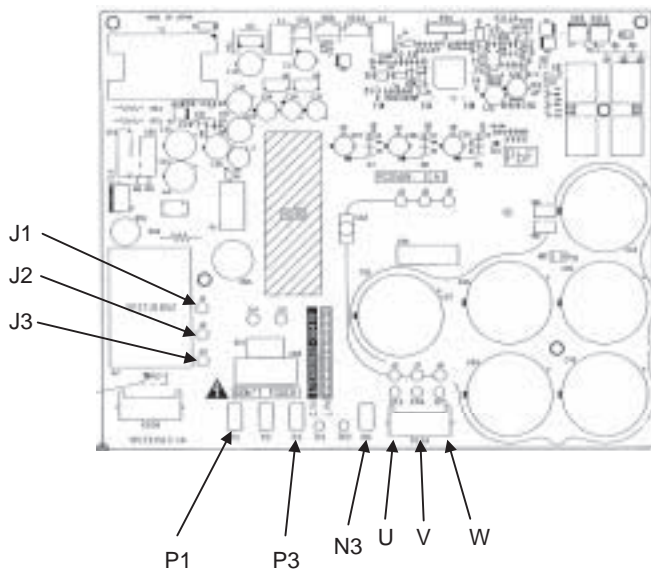

(V2895)

[CHECK 5] Check for causes of rise in high pressure

Referring to the Fault Tree Analysis (FTA) shown below, probe the faulty points.

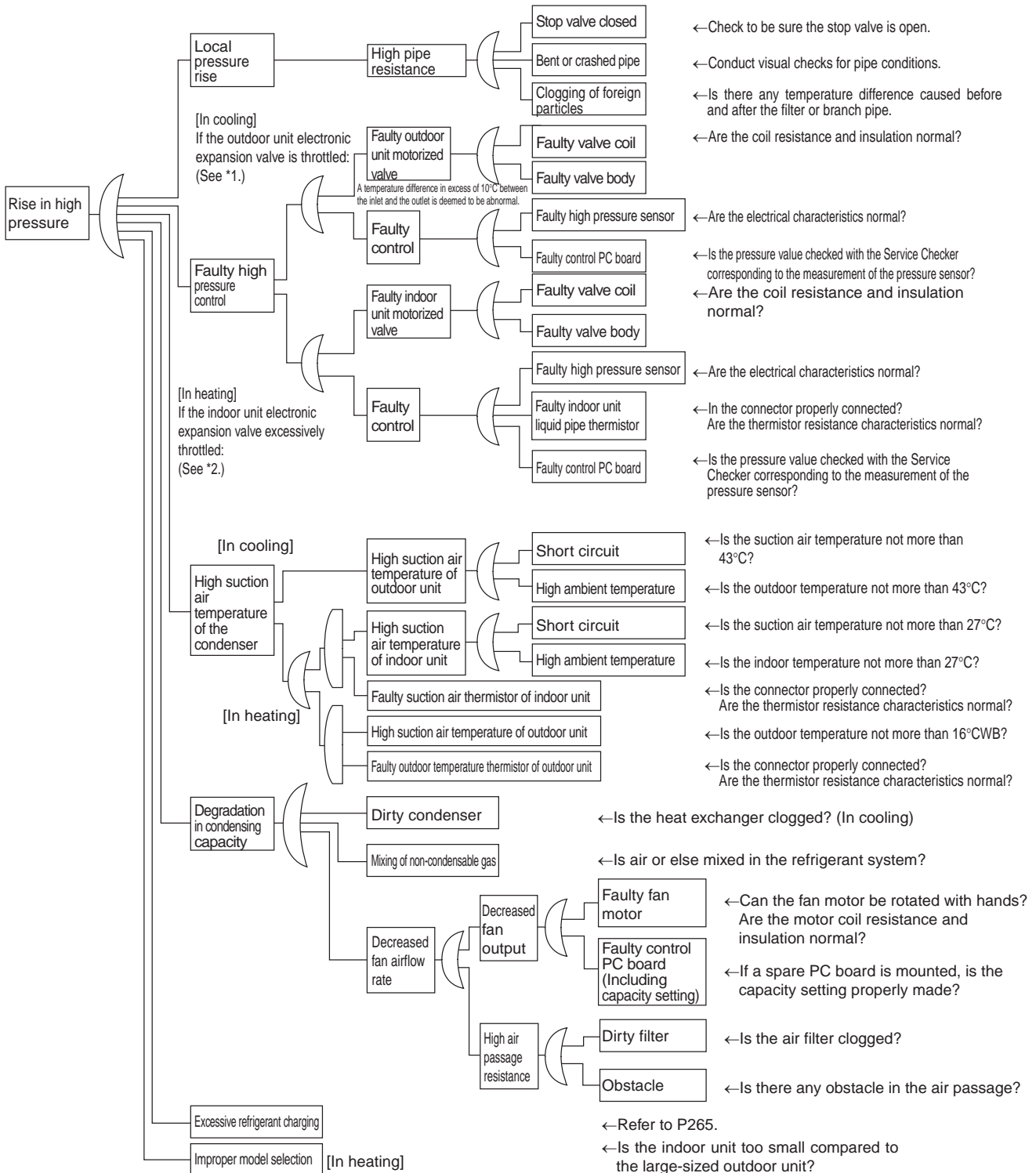

*1: In cooling, it is normal if the outdoor unit electronic expansion valve (EVM) is fully open.

*2: In heating, the indoor unit electronic expansion valve is used for "subcooled degree control". (For details, refer to "Electronic Expansion Valve Control" on P141.)

[CHECK 6] Check for causes of drop in low pressure

Referring to the Fault Tree Analysis (FTA) shown below, probe the faulty points.

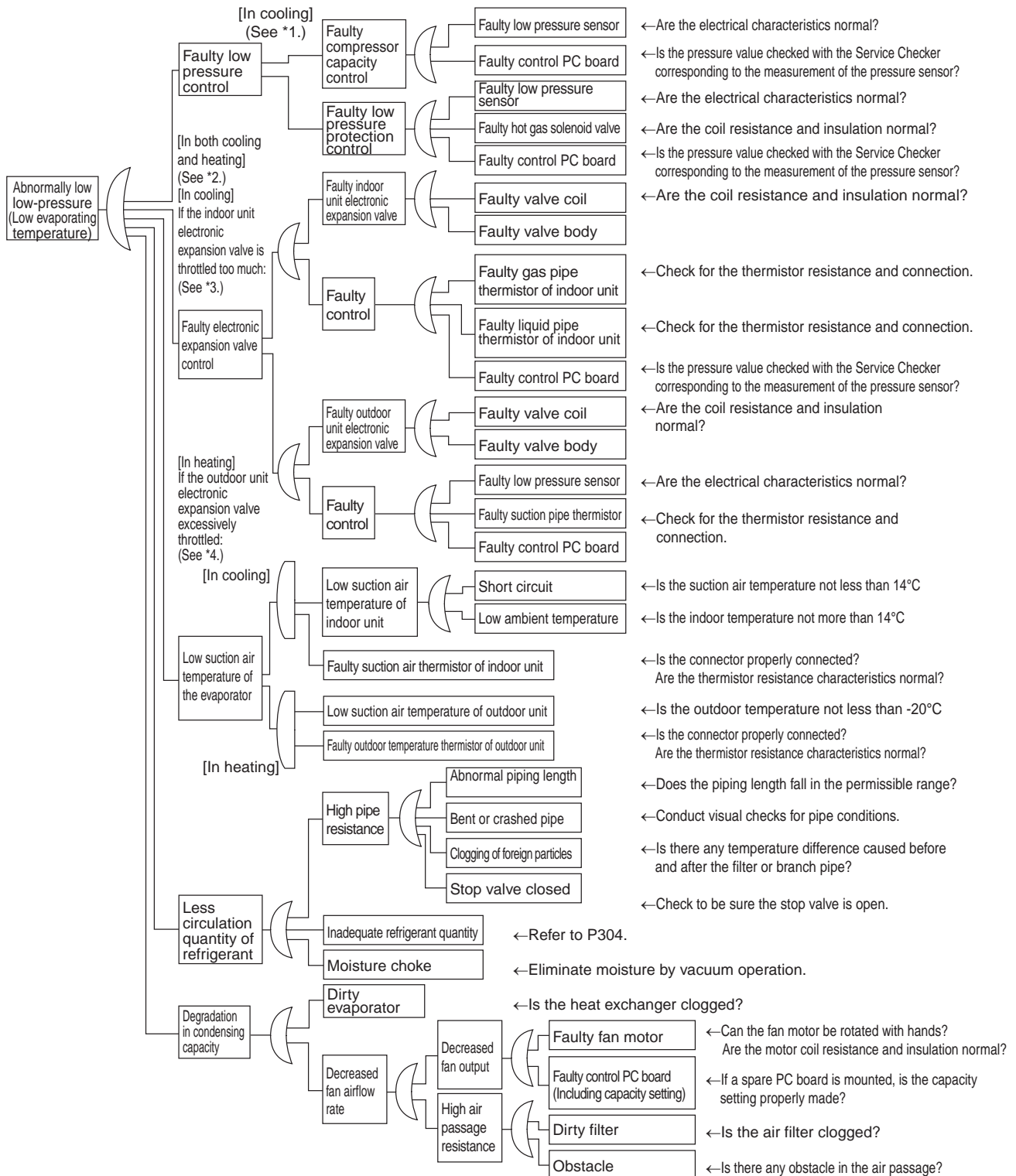

*1: For details of the compressor capacity control while in cooling, refer to "Compressor PI Control" on P100.
 *2: The "low pressure protection control" includes low pressure protection control and hot gas bypass control. For details, refer to P126.
 *3: In cooling, the indoor unit electronic expansion valve is used for "superheated degree control". (For details, refer to P141.)
 *4: In heating, the outdoor unit electronic expansion valve (EVM) is used for "superheated degree control of outdoor unit heat exchanger". (For details, refer to P108.)

[CHECK 7] Broken Wire Check of the Connecting Wires

1. Procedure for checking outdoor-outdoor unit transmission wiring for broken wires
 On the system shown below, turn OFF the power supply to all equipment, short-circuit between the outdoor-outdoor unit terminal parts F1 and F2 in the "Outdoor Unit A" that is farthest from the central remote control, and then conduct continuity checks between the transmission wiring terminal blocks F1 and F2 of the central remote control using a multiple meter. If there is continuity between the said terminal blocks, the outdoor-outdoor unit transmission wiring has no broken wires in it.
 If there is no continuity, the transmission wiring may have broken wires. With the outdoor-outdoor unit terminal parts of the "Outdoor Unit A" short-circuited, conduct continuity checks between the transmission wiring terminal blocks F1 and F2 of the unified ON/OFF controller. If there is no continuity as well, conduct continuity checks between the outdoor-outdoor unit terminal parts of the "Outdoor Unit E", between the outdoor-outdoor unit terminal parts of the "Outdoor Unit D", between the outdoor-outdoor unit terminal parts of the "Outdoor Unit C", ... in the order described, thus identifying the place with continuity.
 If the place with continuity can be identified, there may be broken wires in places before the said place with continuity.
2. Procedure for checking indoor-outdoor unit transmission wiring for broken wires (for checking the indoor-outdoor unit transmission wiring of the "Outdoor Unit C" for broken wires)
 Turn OFF the power supply to all equipment, short-circuit between the indoor-outdoor unit terminal parts F1 and F2 in the "Outdoor Unit C, and then conduct continuity checks between the transmission wirings F1 and F2 of the "Indoor Unit a" that is farthest from the "Outdoor Unit C" using a multiple meter. If there is continuity between the said transmission wirings, the indoor-outdoor unit transmission wiring has no broken wires in it.
 If there is no continuity, the transmission wiring may have broken wires. With the indoor-outdoor unit terminal parts of the "Outdoor Unit C" short-circuited, identify the place with continuity in the transmission wiring of the "Indoor Unit b", transmission wiring of the "Indoor Unit c", and transmission wiring of the "Indoor Unit d" in the order described.
 If the place with continuity can be identified, there may be broken wires in places before the said place with continuity.

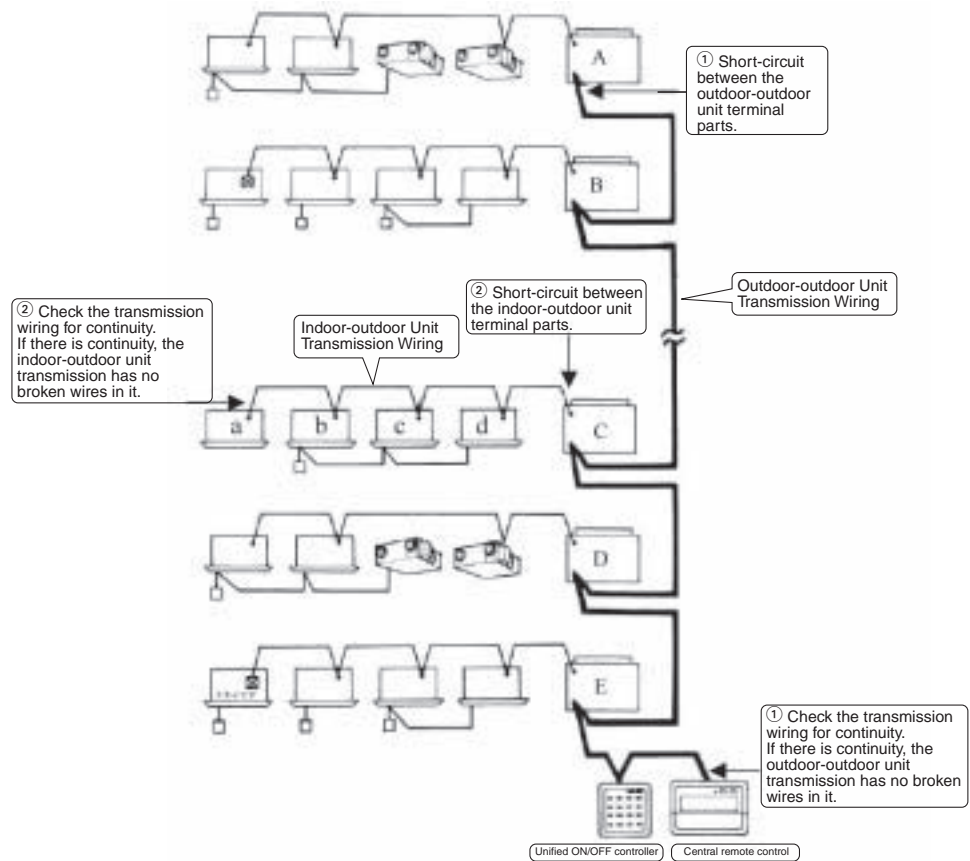

[CHECK 8] Master Unit Central Connector Setting Table

The master unit central setting connector (CN1/X1A) is mounted at the factory.

- To independently use a single unit of the intelligent Touch controller or a single unit of the central remote control, do not dismount the master unit central setting connector (i.e., use the connector with the factory setting unchanged).
- To independently use the schedule timer, insert an independent-use setting connector. No independent-use setting connector has been mounted at the factory. Insert the connector, which is attached to the casing of the main unit, in the PC board (CN1/X1A). (Independent-use connector=Master unit central setting connector)
- To use two or more central equipment in combination, make settings according to the table shown below.

Pattern	Central equipment connection pattern				Setting of master unit central setting connector(*2)				
	Intelligent Touch controller	Central remote control	Unified ON/OFF controller	Schedule timer	Intelligent Touch controller	Central remote control	Unified ON/OFF controller	Schedule timer	
①	1 to 2 units	/	/	x (*1)	Only a single unit: "Provided", Others: "Not provided"	/	/	/	
②	1 unit	1 unit	/	x (*1)	Provided	Not provided	/	/	
③			/	x (*1)			/		
④	1 to 2 units	/	1 to 8 units	x (*1)	Only a single unit: "Provided", Others: "Not provided"	/	All "Not provided"	/	
⑤	/	1 to 4 units	/	/	Only a single unit: "Provided", Others: "Not provided"	Only a single unit: "Provided", Others: "Not provided"	/	/	
⑥	/		1 to 16 units	1 unit			/	All "Not provided"	Not provided
⑦	/		/	1 unit			/	/	Not provided
⑧	/		/	1 unit			/	/	Not provided
⑨	/	/	/	/	/	/	Only a single unit: "Provided", Others: "Not provided"	/	
⑩	/	/	1 to 16 units	1 unit	/	/	Only a single unit: "Provided", Others: "Not provided"	Not provided	
⑪	/	/	/	1 unit	/	/	/	Provided	

(*1) The intelligent Touch controller and the schedule timer are not available for combined use.

(*2) The intelligent Touch controller, central remote control, and the unified ON/OFF controller have been set to "Provided with the master unit central setting connector" at the factory. The schedule timer has been set to "Not provided with the master unit central setting connector" at the factory, which is attached to the casing of the main unit.

[CHECK 9] Master-Slave Unit Setting Table

Combination of Intelligent Touch Controller and Central Remote Control



*	#1		#2		#3		#4	
Pattern	1-00~4-15	Master/Slave	5-00~8-15	Master/Slave	1-00~4-15	Master/Slave	5-00~8-15	Master/Slave
①	CRC	Master	CRC	Master	CRC	Slave	CRC	Slave
②	CRC	Master	—	—	CRC	Slave	—	—
③	Intelligent Touch controller	Master	—	—	Intelligent Touch controller	Slave	—	—
④	CRC	Master	—	—	Intelligent Touch controller	Slave	—	—
⑤	Intelligent Touch controller	Master	—	—	CRC	Slave	—	—
⑥	CRC	Master	—	—	—	—	—	—
⑦	Intelligent Touch controller	Master	—	—	—	—	—	—

CRC: Central remote control <DCS302CA61>

Intelligent Touch controller: <DCS601C51>

The patterns marked with "" have nothing to do with those described in the list of Setting of master unit central setting connector.

[Check 10] Check for causes of wet operation.

Referring to the Fault Tree Analysis (FTA) shown below, identify faulty points.

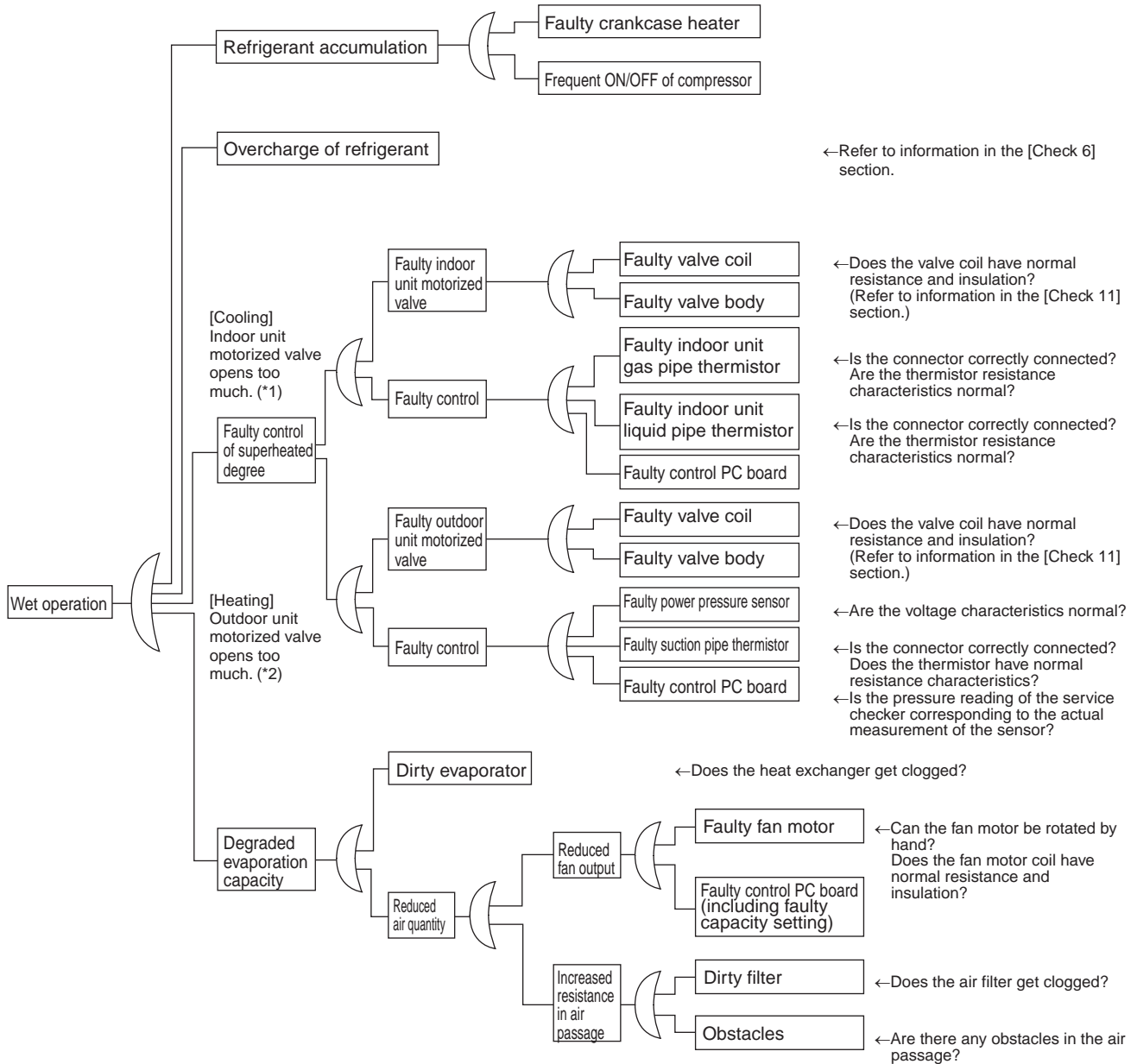

*1: "Superheated degree control" in cooling operation is exercised with the indoor unit motorized valve. (Refer to information on P141.)
 *2: "Superheated degree control" in heating operation is exercised with the outdoor unit motorized valve (EV1). (Refer to information on P108.)
 *3: Guideline of superheated degree to judge as wet operation
 ① Suction gas superheated degree: Not more than 3°C; ② Discharge gas superheated degree: Not more than 15°C, except immediately after compressor starts up or is running under drooping control. (Use the values shown above as a guideline. Even if the superheated degree falls in the range, the compressor may be normal depending on other conditions.)

[Check 11] Check for overcharge of refrigerant.

In case of VRV Systems, the only way to judge as the overcharge of refrigerant is with operating conditions due to the relationship to pressure control and electronic expansion valve control. As information for making a judgment, refer to information provided below.

Diagnosis of overcharge of refrigerant

1. High pressure rises. Consequently, overload control is exercised to cause scant cooling capacity.
2. The superheated degree of suction gas lowers (or the wet operation is performed). Consequently, the compressor becomes lower in discharge pipe temperature despite of pressure loads.
3. The supercooled degree of condensate rises. Consequently, in heating operation, the temperature of outlet air passing through the supercooled section becomes lower.

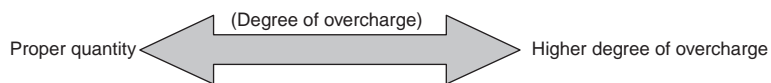
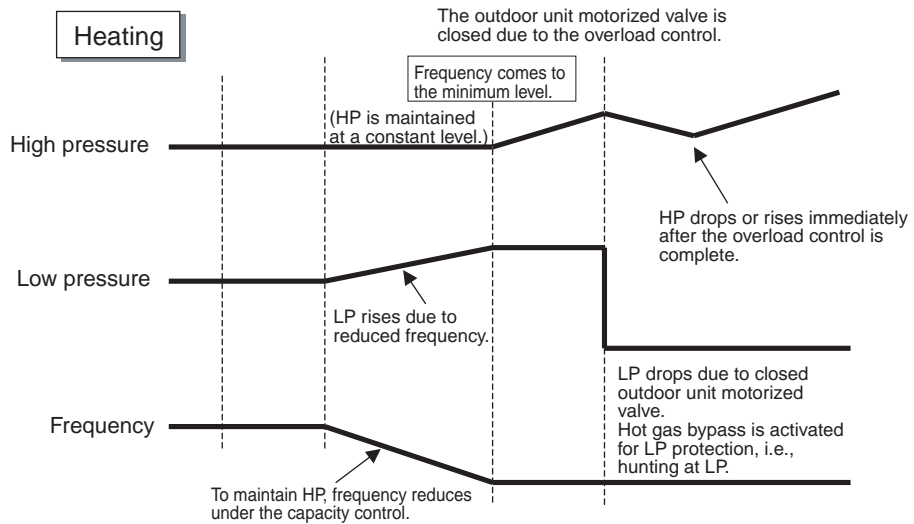
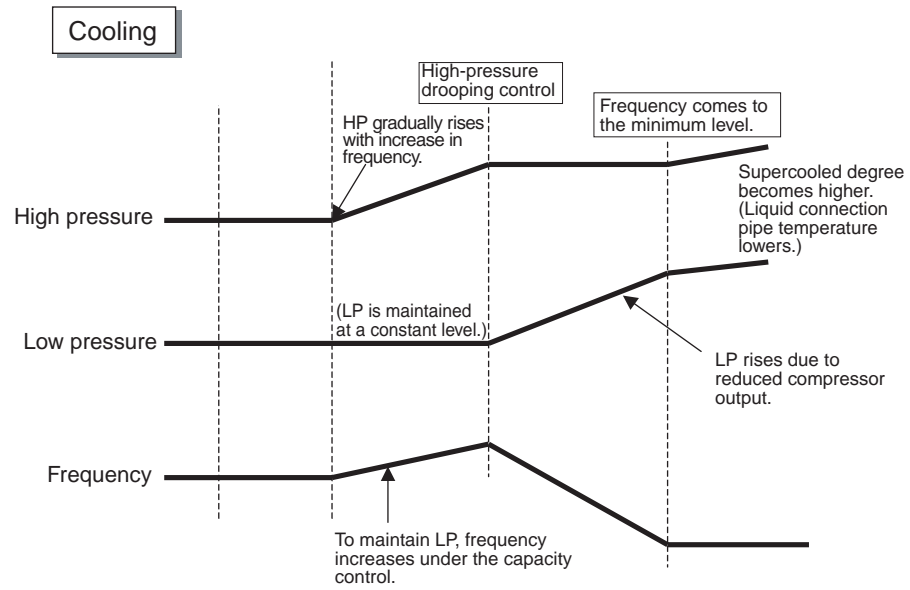

[Check 13] Vacuuming and dehydration procedure

Conduct vacuuming and dehydration in the piping system following the procedure for <Normal vacuuming and dehydration> described below.

Furthermore, if moisture may get mixed in the piping system, follow the procedure for <Special vacuuming and dehydration> described below.

<Normal vacuuming and dehydration>

① Vacuuming and dehydration

- Use a vacuum pump that enables vacuuming up to 100.7kPa (5 torr, -755 mmHg).
- Connect manifold gauges to the service ports of liquid pipe and gas pipe and run the vacuum pump for a period of two or more hours to conduct evacuation to -100.7kPa or less.
- If the degree of vacuum does not reach -100.7kPa or less even though evacuation is conducted for a period of two hours, moisture will have entered the system or refrigerant leakage will have been caused. In this case, conduct evacuation for a period of another one hour.
- If the degree of vacuum does not reach -100.7kPa or less even though evacuation is conducted for a period of three hours, conduct leak tests.

② Leaving in vacuum state

- Leave the compressor at the degree of vacuum of -100.7kPa or less for a period of one hour or more, and then check to be sure that the vacuum gauge reading does not rise. (If the reading rises, moisture may have remained in the system or refrigerant leakage may have been caused.)

③ Refrigerant charge

- Purge air from the manifold gauge connection hoses, and then charge a necessary quantity of refrigerant.

<Special vacuuming and dehydration> - In case moisture may get mixed in the piping*

① Vacuuming and dehydration

- Follow the same procedure as that for 1) Normal vacuuming and dehydration described above.

② Vacuum break

- Pressurize with nitrogen gas up to 0.05MPa.

③ Vacuuming and dehydration

- Conduct vacuuming and dehydration for a period of one hour or more. If the degree of vacuum does not reach -100.7kPa or less even though evacuation is conducted for a period of two hours or more, repeat vacuum break - vacuuming and dehydration.

④ Leaving in vacuum state

- Leave the compressor at the degree of vacuum of -100.7kPa or less for a period of one hour or more, and then check to be sure that the vacuum gauge reading does not rise.

⑤ Refrigerant charge

- Purge air from the manifold gauge connection hoses, and then charge a necessary quantity of refrigerant.

- * In case of construction during rainy reason, if dew condensation occurs in the piping due to extended construction period, or rainwater or else may enter the piping during construction work:

[Check 14] List of inverter-related malfunction codes

	Code	Name	Condition for determining malfunction	Major cause
Compressor current	L5	Instantaneous overcurrent of inverter compressor	<ul style="list-style-type: none"> Inverter output current exceeds 32.3A even instantaneously. 	<ul style="list-style-type: none"> Liquid sealing Faulty compressor Faulty inverter PC board
	L8	Overcurrent of inverter compressor (Electronic thermal)	<ul style="list-style-type: none"> Compressor overload running An overcurrent of 19.0A or more continues for a period of 5 consecutive seconds or that of 16.1A or more continues for a period of 260 consecutive seconds. The inverter loses synchronization. 	<ul style="list-style-type: none"> Backflow of compressor liquid Sudden changes in loads Disconnected compressor wiring Faulty inverter PC board
Protection device and others	L1	Faulty inverter PC board	<ul style="list-style-type: none"> No output is given. 	<ul style="list-style-type: none"> Faulty heavy current part of compressor
	L9	Faulty startup of inverter compressor	<ul style="list-style-type: none"> The compressor motor fails to start up. 	<ul style="list-style-type: none"> Liquid sealing or faulty compressor Excessive oil or refrigerant Faulty inverter PC board
	E5	Inverter compressor lock	<ul style="list-style-type: none"> The compressor is in the locked status (does not rotate). 	<ul style="list-style-type: none"> Faulty compressor
	L4	Radiator fin temperature rise	<ul style="list-style-type: none"> The radiator fin temperature reaches 87°C or more (while in operation). 	<ul style="list-style-type: none"> Malfunction of fan Running in overload for an extended period of time Faulty inverter PC board
	U2	Power supply voltage error	<ul style="list-style-type: none"> The inverter power supply voltage is high or low. 	<ul style="list-style-type: none"> Power supply error Faulty inverter PC board
	P1	Imbalanced power supply	<ul style="list-style-type: none"> Power supply voltages get significantly imbalanced among three phases. 	<ul style="list-style-type: none"> Power supply error (imbalanced voltages of 2% or more) Faulty inverter PC board Dead inverter PC board
	LC	Transmission error (between inverter PC board and control PC board)	<ul style="list-style-type: none"> With the outdoor unit PC board, no communications are carried out across control PC board - inverter PC board - fan PC board. 	<ul style="list-style-type: none"> Broken wire in communication line Faulty control PC board Faulty inverter PC board Faulty fan PC board
	PJ	PC board mismatching	<ul style="list-style-type: none"> Any PC board of specification different from that of the product is connected. 	<ul style="list-style-type: none"> PC board of different specification mounted
	P4	Faulty fin thermistor	<ul style="list-style-type: none"> The fin thermistor gets short-circuited or open. 	<ul style="list-style-type: none"> Faulty fin thermistor

[Check 15] Concept of inverter-related malfunction codes

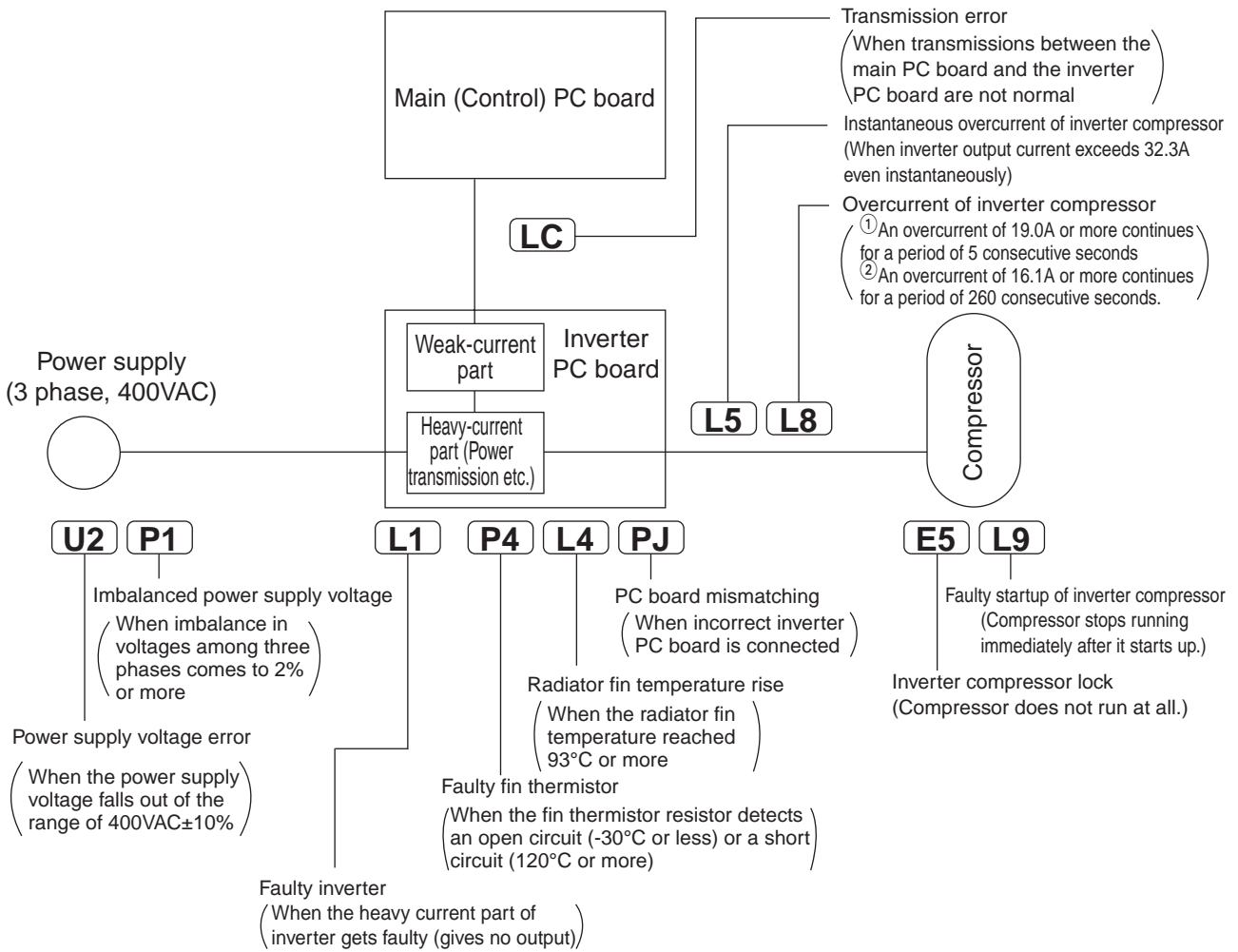

Malfunction codes related to compressor current

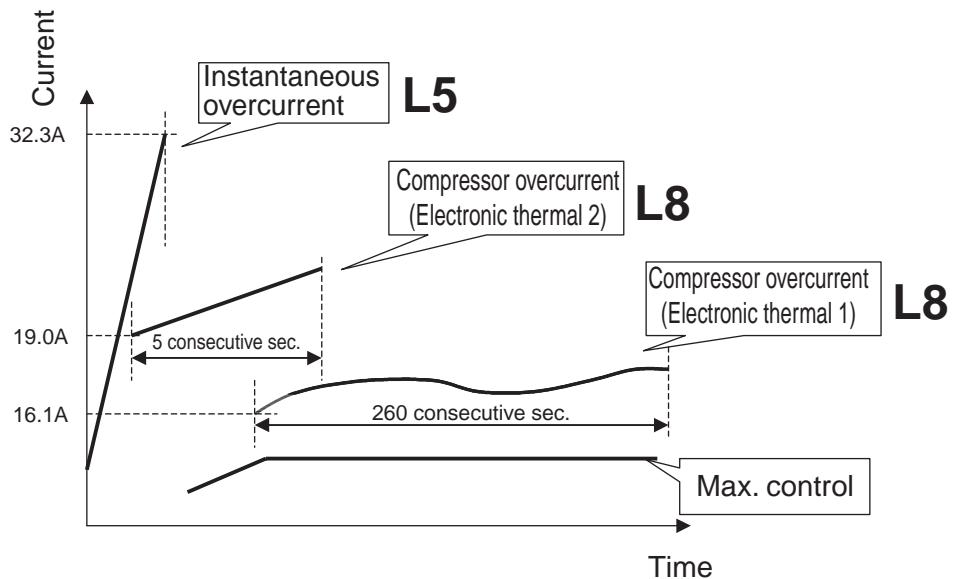

Part 7

Appendix

1. Piping Diagrams.....	398
1.1 Outdoor Unit.....	398
1.2 Indoor Unit.....	403
1.3 BS Unit.....	409
2. Wiring Diagrams for Reference.....	410
2.1 Outdoor Unit.....	410
2.2 Field Wiring.....	415
2.3 Indoor Unit.....	418
2.4 BS Unit.....	434
3. List of Electrical and Functional Parts.....	435
3.1 Outdoor Unit.....	435
3.2 Indoor Side.....	439
4. Option List.....	445
4.1 Option List of Controllers.....	445
4.2 Option Lists (Outdoor Unit).....	447
5. Piping Installation Point.....	448
5.1 Piping Installation Point.....	448
5.2 The Example of a Wrong Pattern.....	449
6. Example of connection (R-410A Type).....	451
7. Thermistor Resistance / Temperature Characteristics.....	455
8. Pressure Sensor.....	457
9. Method of Checking the Inverter's Power Transistors and Diode Modules.....	458
9.1 Method of Checking the Inverter's Power Transistors and Diode Modules.....	458

1. Piping Diagrams

1.1 Outdoor Unit

REYQ8P / 10P / 12P

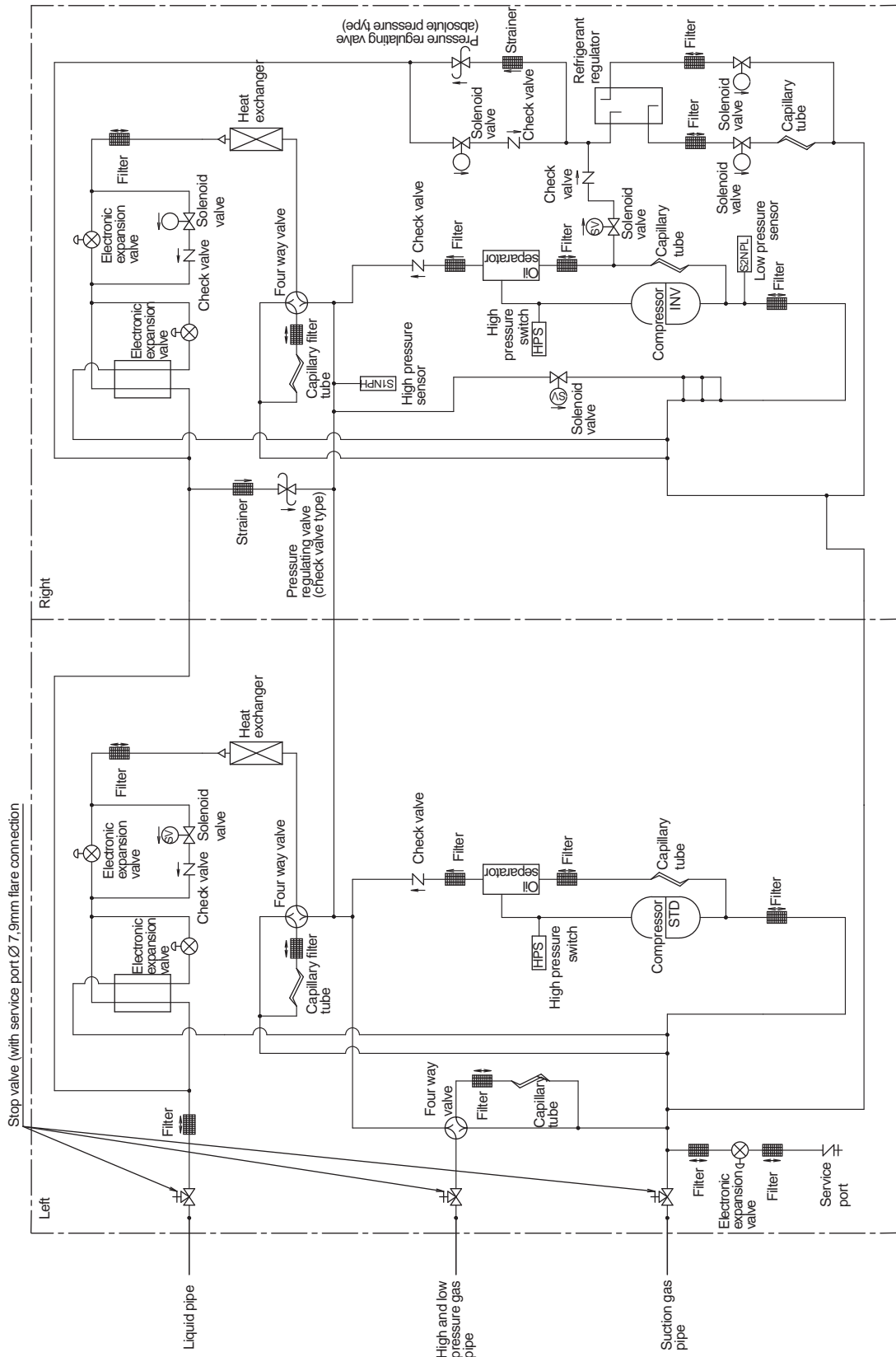

3D058154B

REYQ14P / 16P

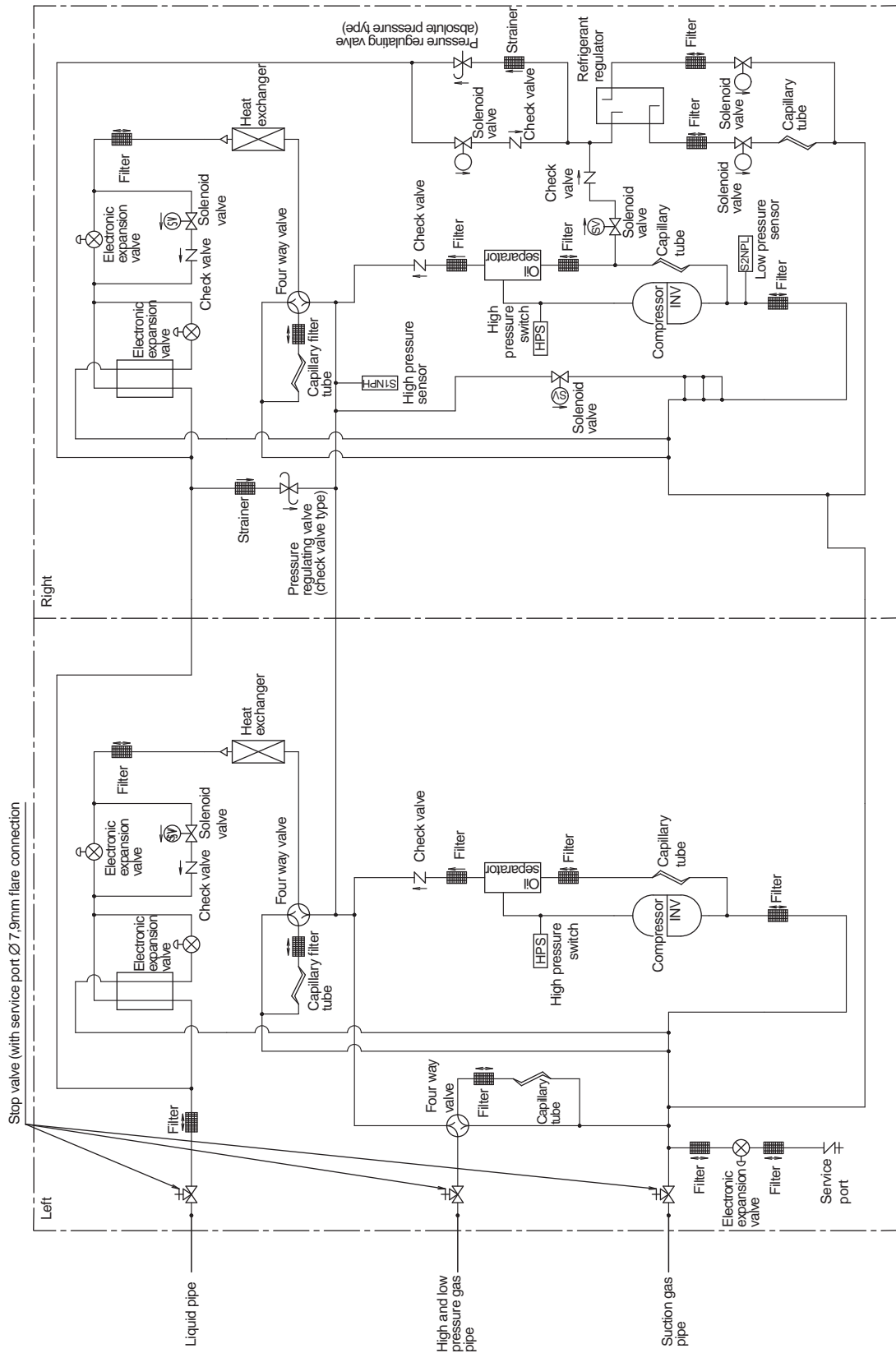

3D058153B

REM08P

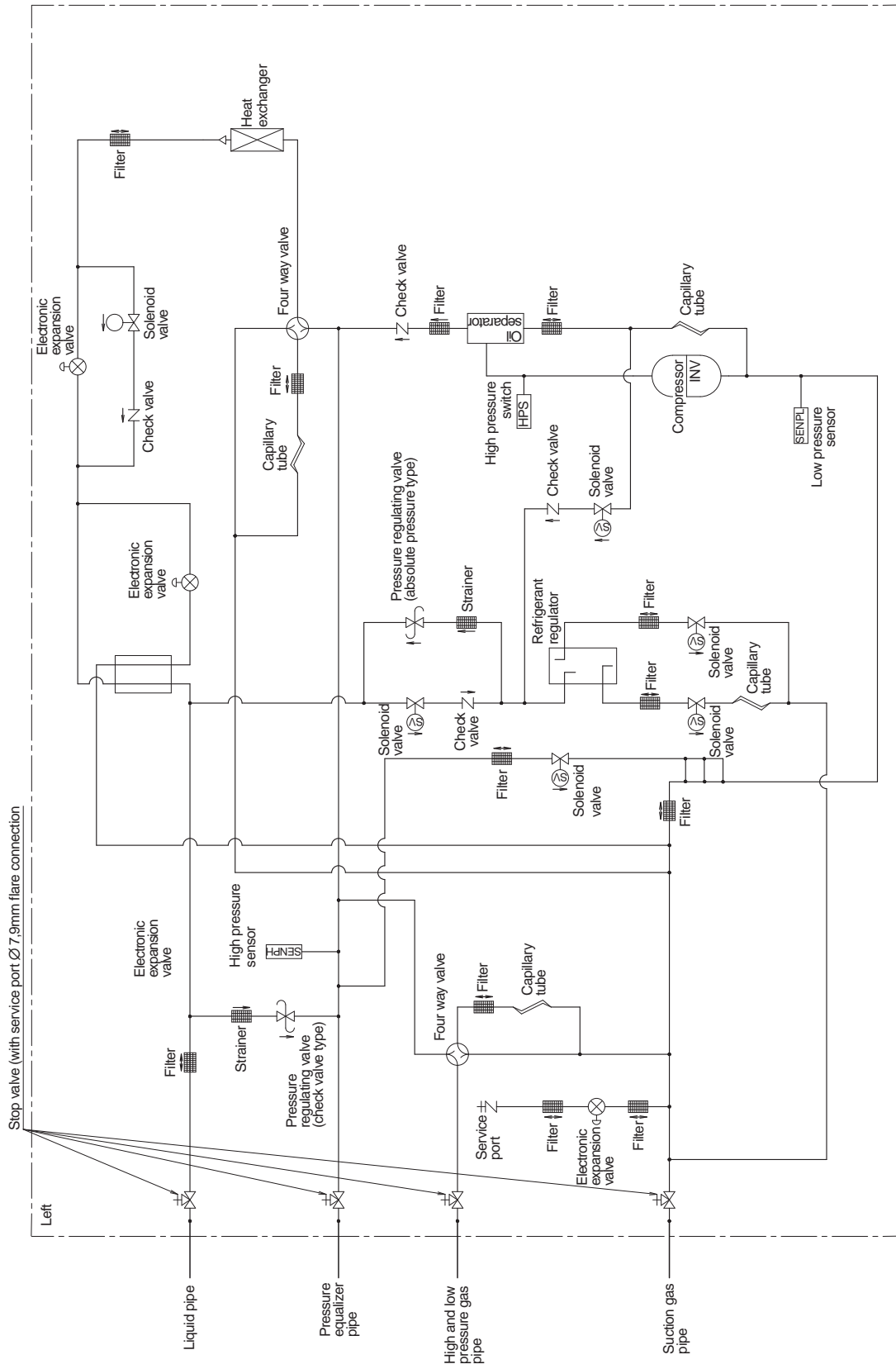

3D057743

1.2 Indoor Unit

FXFQ-P

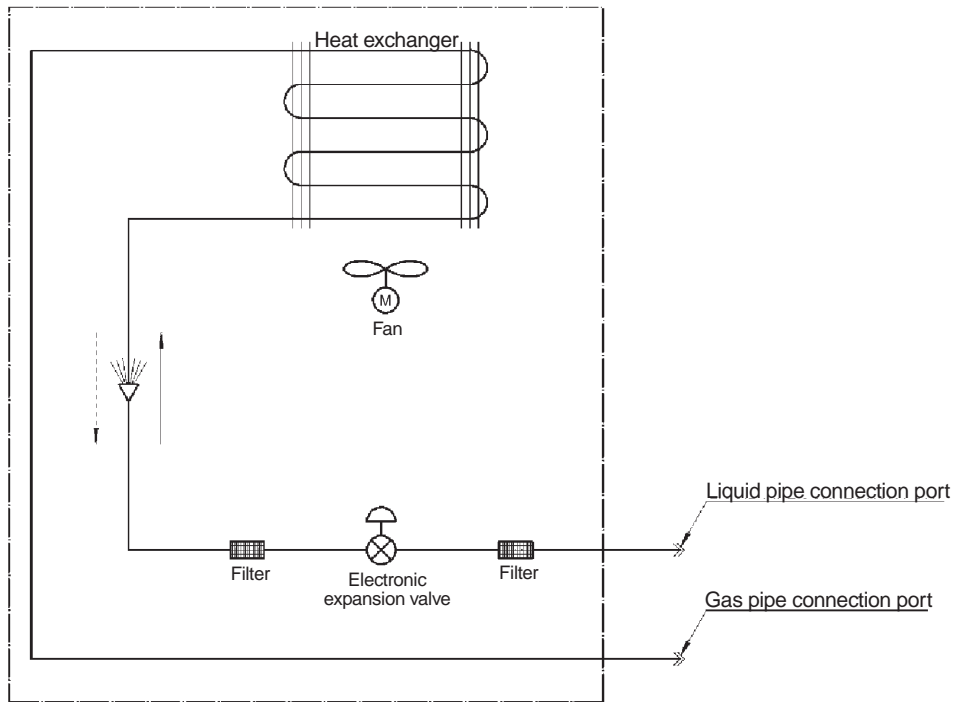

Refrigerant flow
 Cooling ———→
 Heating - - - - -→

Refrigerant pipe connection port diameters

Model	Gas	Liquid
FXFQ20, 25, 32, 40, 50P	Ø12.70	Ø6.35
FXFQ63, 80, 100, 125P	Ø15.90	Ø9.45

3TW28835-1

FXZQ

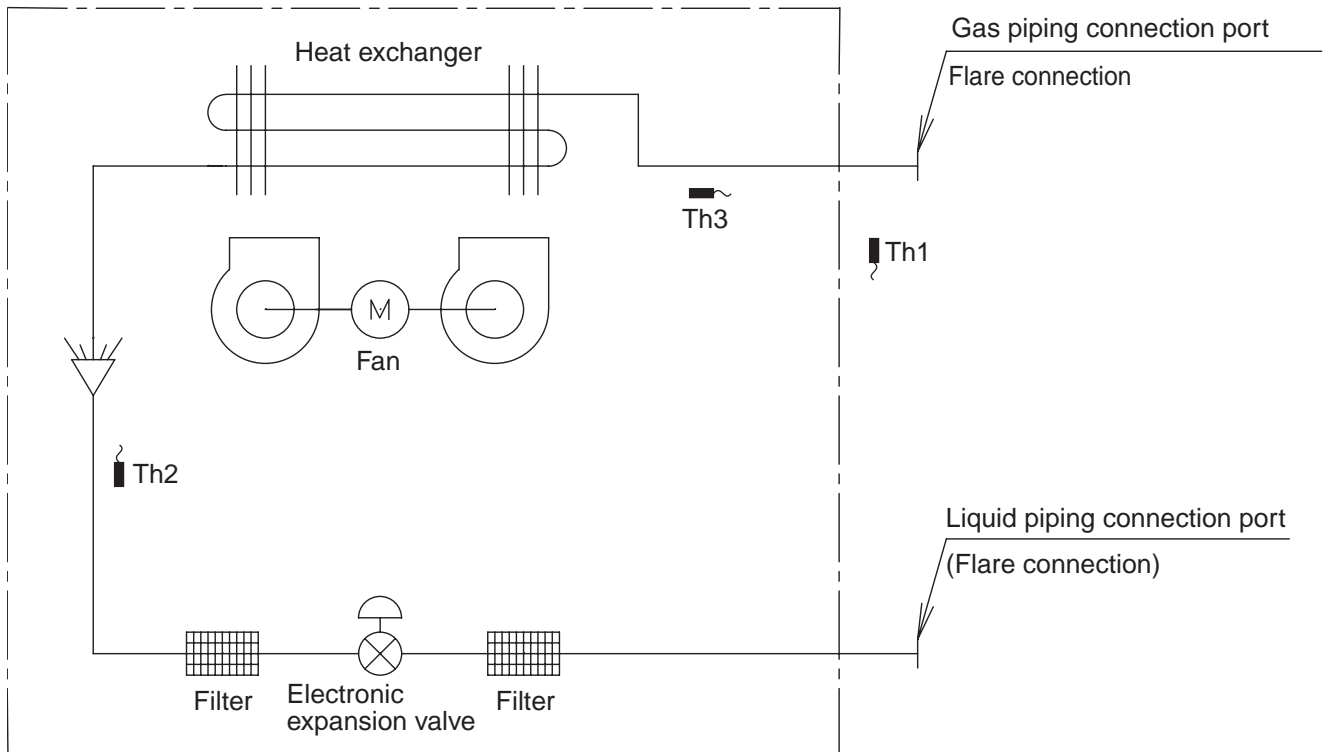

Th1: Thermister for suction air temp.
 Th2: Thermister for liquid line temp.
 Th3: Thermister for gas line temp.

4D040157

■ Refrigerant pipe connection port diameters

Model	(mm)	
	Gas	Liquid
FXZQ20M / 25M / 32M / 40M / 50M	φ12.7	φ6.4

FXCQ, FXDQ20/25-M, FXSQ

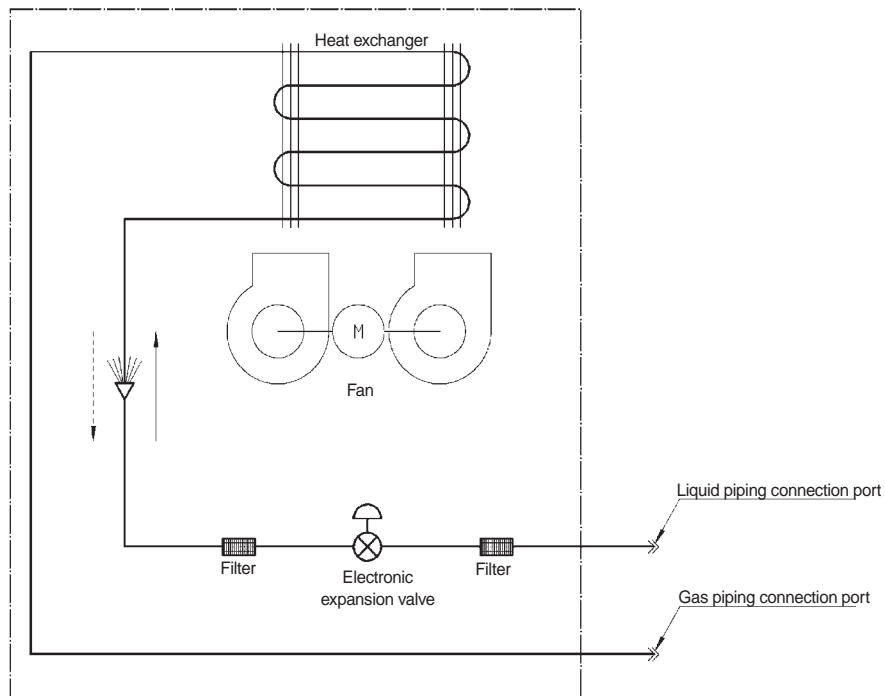

Refrigerant flow
 Cooling —————→
 Heating - - - - -→

■ Refrigerant pipe connection port diameters

Model	Gas	Liquid
FXSQ20, 25, 32, 40, 50	φ12.70	φ6.35
FXSQ63, 80, 100, 125	φ15.90	φ9.52
FXCQ20, 25, 32, 40, 50	φ12.70	φ6.35
FXCQ63, 80, 125	φ15.90	φ9.52
FXDQ20, 25	φ12.70	φ6.35

C:3TW25515-1
 C:3TW21175-1C

FXKQ-MA

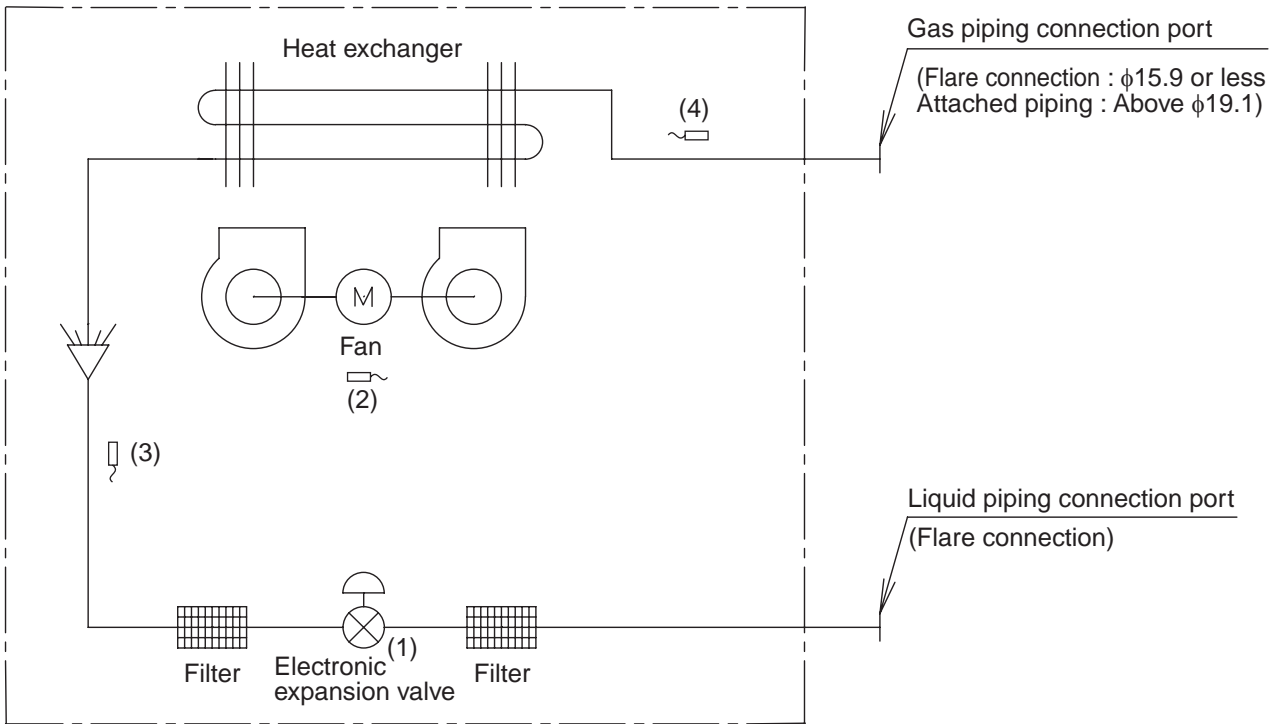

Code	Name	Code	Main function
(1)	Electronic expansion valve	Y1E	Used for gas superheated degree control while in cooling operation or subcooled degree control while in heating operation.
(2)	Suction air temperature thermistor	R1T	Used for thermostat control.
(3)	Liquid pipe	R2T	Used for gas superheated degree control while in cooling operation or subcooled degree control while in heating operation.
(4)	Gas pipe	R3T	Used for gas superheated degree control while in cooling operation.

(mm)

Capacity	GAS	Liquid
25 / 32 / 40 / 50MA	φ12.7	φ6.4
63MA	φ15.9	φ9.5

4D034245C

FXDQ-NA, P

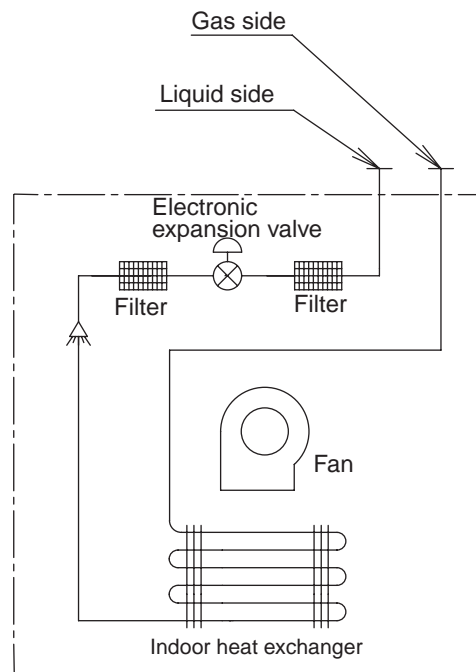

4D043864H

■ Refrigerant pipe connection port diameters

(mm)

Model	Gas	Liquid
FXDQ20NA, P / 25NA, P / 32NA, P / 40NA / 50NAVE	φ12.7	φ6.4
FXDQ63NAVE	φ15.9	φ9.5

FXUQ + BEVQ

Indoor Unit

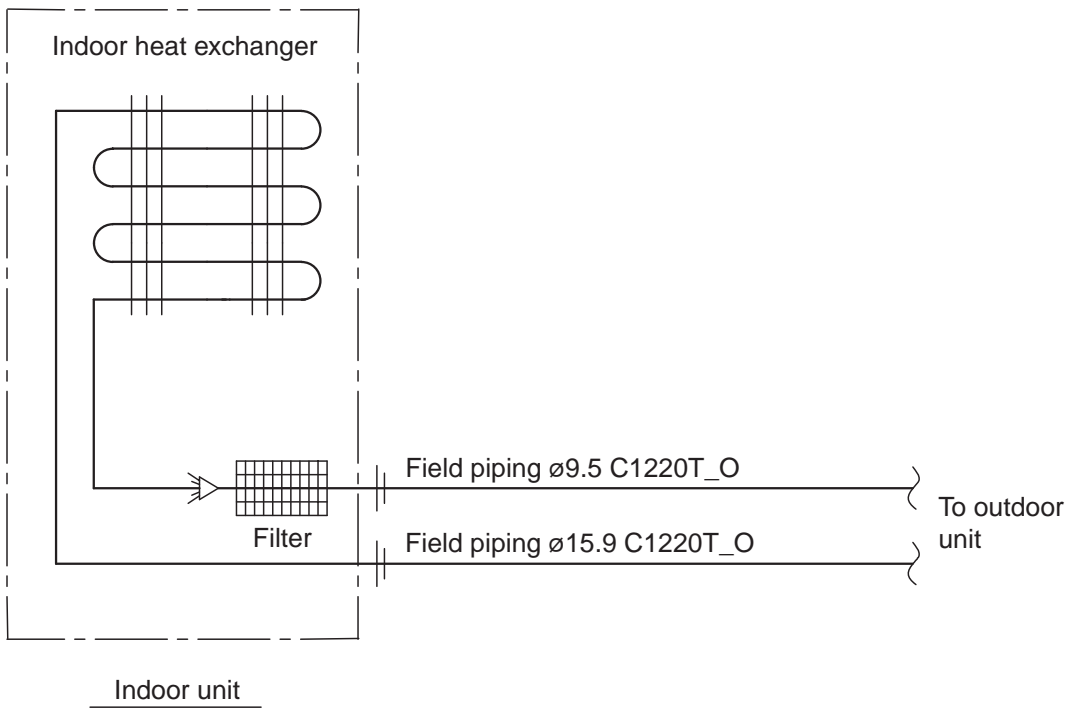

4D037995F

Connection Unit

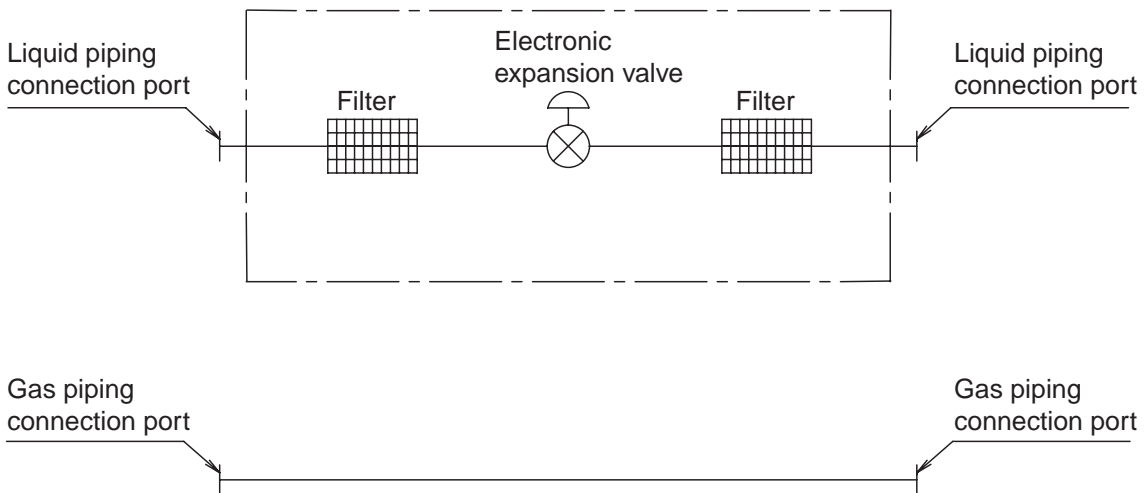

4D034127B

1.3 BS Unit

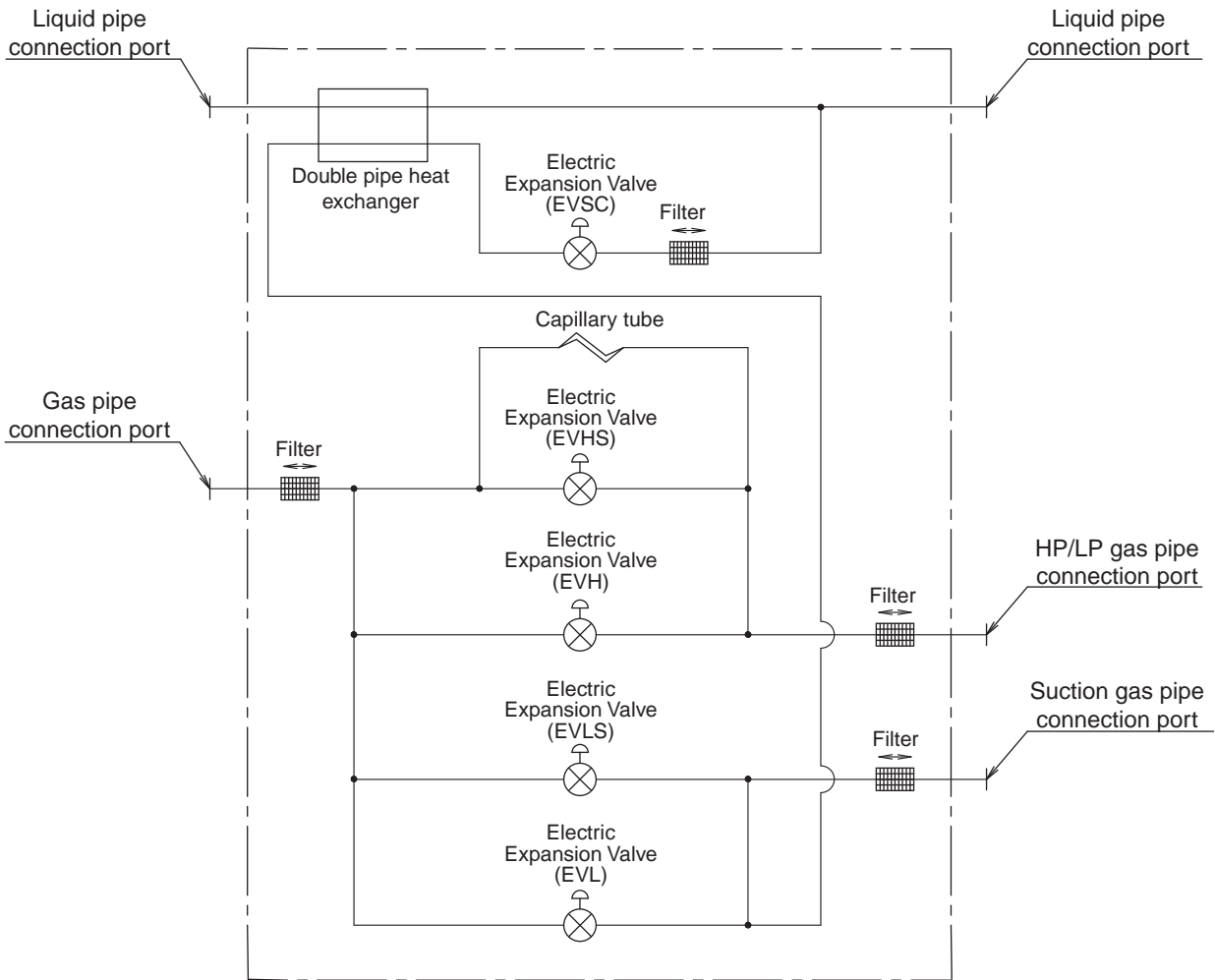

4D057985A

2. Wiring Diagrams for Reference

2.1 Outdoor Unit

REYQ8P / 10P / 12P8Y1B

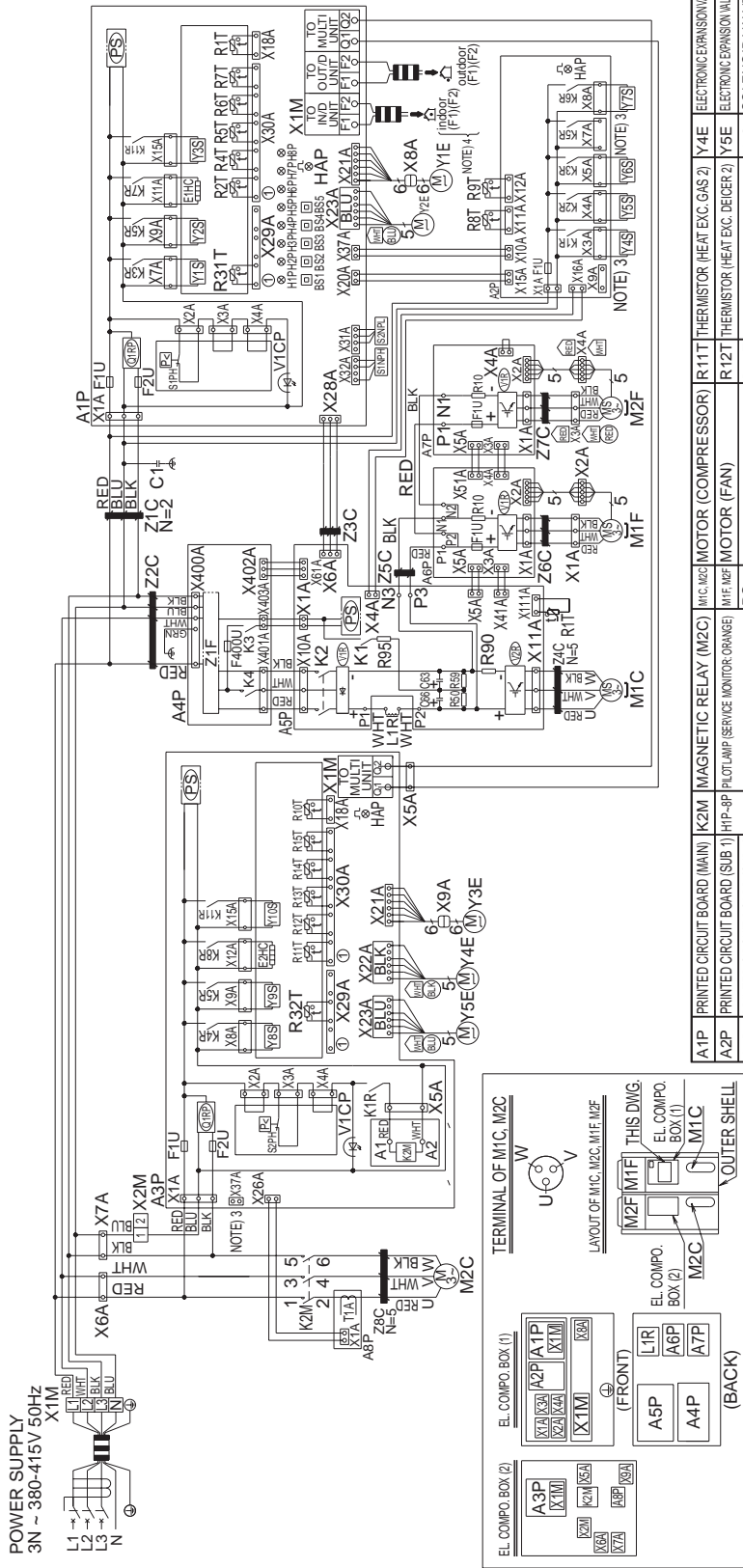

A1P	PRINTED CIRCUIT BOARD (MAIN)	K2M	MAGNETIC RELAY (M2C)	R11T	THERMISTOR (COMPRESSOR)	R11T	THERMISTOR (HEAT EXC. GAS 2)	Y4E	ELECTRONIC EXPANSION VALVE (CHARGE)
A2P	PRINTED CIRCUIT BOARD (SUB 1)	K2M	Pilot Lamp (Service Monitor, Orange)	R12T	MOTOR (FAN)	R12T	THERMISTOR (HEAT EXC. DECER 2)	Y4E	ELECTRONIC EXPANSION VALVE (SUBCOOL 2)
A3P	PRINTED CIRCUIT BOARD (SUB 2)	K2M	Fluorescent Lamp (Pre-heat, Test)	R13T	SWITCHING POWER SUPPLY (AP, AP2, AP3)	R13T	THERMISTOR (SUB COOL. HEAT EXC. GAS 2)	Y1S	SOLENOID VALVE (RMTG)
A4P	PRINTED CIRCUIT BOARD (NOISE FILTER)	K2M	MAF-Function Detection - Light Up	Q1RP	PHASE-REVERSAL DETECT. CIRCUIT (AP1, AP2)	R14T	THERMISTOR (LIQUID 2)	Y2S	SOLENOID VALVE (4WAY VALVE-HEAT EXC.1)
A5P	PRINTED CIRCUIT BOARD (FAN)	HAP	MAF-Function Detection - Light Up	R10	RESISTOR (CURRENT SENSOR) (AP1, AP2)	R15T	THERMISTOR (HEAT EXC. LIQUID 2)	Y3S	SOLENOID VALVE (RMTL)
A6P	PRINTED CIRCUIT BOARD (MODE)	K1R	MAGNETIC RELAY (Y4S) (A2P)	R50, R50	RESISTOR (CURRENT SENSOR)	S1PH	PRESSURE SENSOR (HIGH)	Y4S	SOLENOID VALVE (HOT GAS)
A7P	PRINTED CIRCUIT BOARD (MODE)	K2R	MAGNETIC RELAY (Y5S) (A3P)	R90	RESISTOR (CURRENT LIMITING)	S1PH	PRESSURE SENSOR (LOW)	Y5S	SOLENOID VALVE (EV BYPASS 1)
BS1-5	PUSH-BUTTON SWITCH (MODE)	K3R	MAGNETIC RELAY (Y1S) (A1P)	R11T	RESISTOR (CURRENT LIMITING)	S1PH	PRESSURE SWITCH (HIGH)	Y6S	SOLENOID VALVE (RMTT)
C1	CAPACITOR	K3R	MAGNETIC RELAY (Y6S) (A2P)	R1T	THERMISTOR (AIR) (A1P)	T1A	CURRENT SENSOR	Y7S	SOLENOID VALVE (RMTT)
C3, C6	CAPACITOR	K4R	MAGNETIC RELAY (Y8S) (A3P)	R2T	THERMISTOR (FIN) (ASP)	V1CP	SAFETY DEVICES INPUT (AP) (ASP)	Y8S	SOLENOID VALVE (4WAY VALVE-PIPE)
ELC DISC	CRANK/CASE HEATER (A1P) (A3P)	K6R	MAGNETIC RELAY (Y2S) (A1P)	R31T	THERMISTOR (HEAT EXC. GAS 1)	V1R	DIODE BRIDGE (ASP)	Y9S	SOLENOID VALVE (4WAY VALVE-HEAT EXC.2)
F1U	FUSE (T. 3.15A, 250V) (A1P) (A3P)	K6R	MAGNETIC RELAY (FOR OPTION) (A2P)	R32T	THERMISTOR (HEAT EXC. GAS 1)	V1R	DIODE BRIDGE (ASP)	Y10S	SOLENOID VALVE (EV BYPASS 2)
F1U	FUSE (T. 3.15A, 250V) (A2P)	K6R	MAGNETIC RELAY (Y9S) (A3P)	R4T	THERMISTOR (HEAT EXC. DECER 1)	V2R	POWER MODULE (ABP) (A7P)	Z1C-6C	NOISE FILTER (FERRITE CORE)
F1U	FUSE (6A, DC650V) (A6P) (A7P)	K6R	MAGNETIC RELAY (Y7S) (A1P)	R5T	THERMISTOR (HEAT EXC. DECER 1)	X1M	TERMINAL STRIP (POWER SUPPLY)	Z1F	NOISE FILTER (WITH SURGE ABSORBER)
F400U	FUSE (T. 6.3A, 250V)	K7R	MAGNETIC RELAY (EHC) (A1P)	R6T	THERMISTOR (SUB COOL. HEAT EXC. GAS 1)	X1M	TERMINAL STRIP (CONTROL) (AP) (ASP)		
K1	MAGNETIC RELAY	K8R	MAGNETIC RELAY (E2HC) (A3P)	R7T	THERMISTOR (SUB COOL. HEAT EXC. LIQUID)	X2M	TERMINAL STRIP (RELAY)		
K2	MAGNETIC CONTACTOR (M1C)	K8R	MAGNETIC RELAY (Y2HC) (A1P)	R8T	THERMISTOR (HEAT EXC. LIQUID 1)	X1A-X6A	CONNECTOR	X7A	OPERATION OUTPUT (A2P)
K3	MAGNETIC RELAY	K11R	MAGNETIC RELAY (Y10S) (A1P)	R9T	THERMISTOR (SUCTION 1)	Y1E	ELECTRONIC EXPANSION VALVE (MAIN 1)	X9A	POWER SUPPLY (ADAPTER) (A2P)
K4	MAGNETIC CONTACTOR (M1C)	L1R	REACTOR	R10T	THERMISTOR (LIQUID 1)	Y2E	ELECTRONIC EXPANSION VALVE (SUBCOOL. 1)	X37A	POWER SUPPLY (ADAPTER) (A3P)
						Y3E	ELECTRONIC EXPANSION VALVE (MAIN 2)		

- NOTES**
- THIS WIRING DIAGRAM IS APPLIED ONLY TO THE OUTDOOR UNIT.
 - : FIELD WIRING □ : TERMINAL STRIP
 - : CONNECTOR → : TERMINAL
 - ⊕** : PROTECTIVE EARTH (SCREW)
 - WHEN USING THE OPTIONAL ADAPTOR, REFER TO THE INSTALLATION MANUAL OF THE OPTIONAL ADAPTOR.
 - FOR CONNECTION WIRING TO "TO IND UNIT F1 • F2" OR "TO OUT/D UNIT F1 • F2", REFER TO THE INSTALLATION MANUAL.
 - HOW TO USE BS1 ~ 5, REFER TO "SERVICE PRECAUTION" LABEL ON EL. COMPO. BOX (1) COVER.
 - WHEN OPERATING, DON'T SHORTCIRCUIT THE PROTECTION DEVICE (S1, 2PH).
 - ⊕**, **⊖** SYMBOLS INDICATE COLORS OF EACH PARTS AS SHOWN BELOW.
 * IS CONNECTOR COLOR FOR PRINTED CIRCUIT BOARD.
 * IS CONNECTOR COLOR FOR COMPONENT.
 * IS IDENTIFICATION COLOR FOR COMPONENT LEAD WIRE.
 - COLORS BLK : BLACK RED : RED BLU : BLUE WHT : WHITE.

REM08P8Y1B

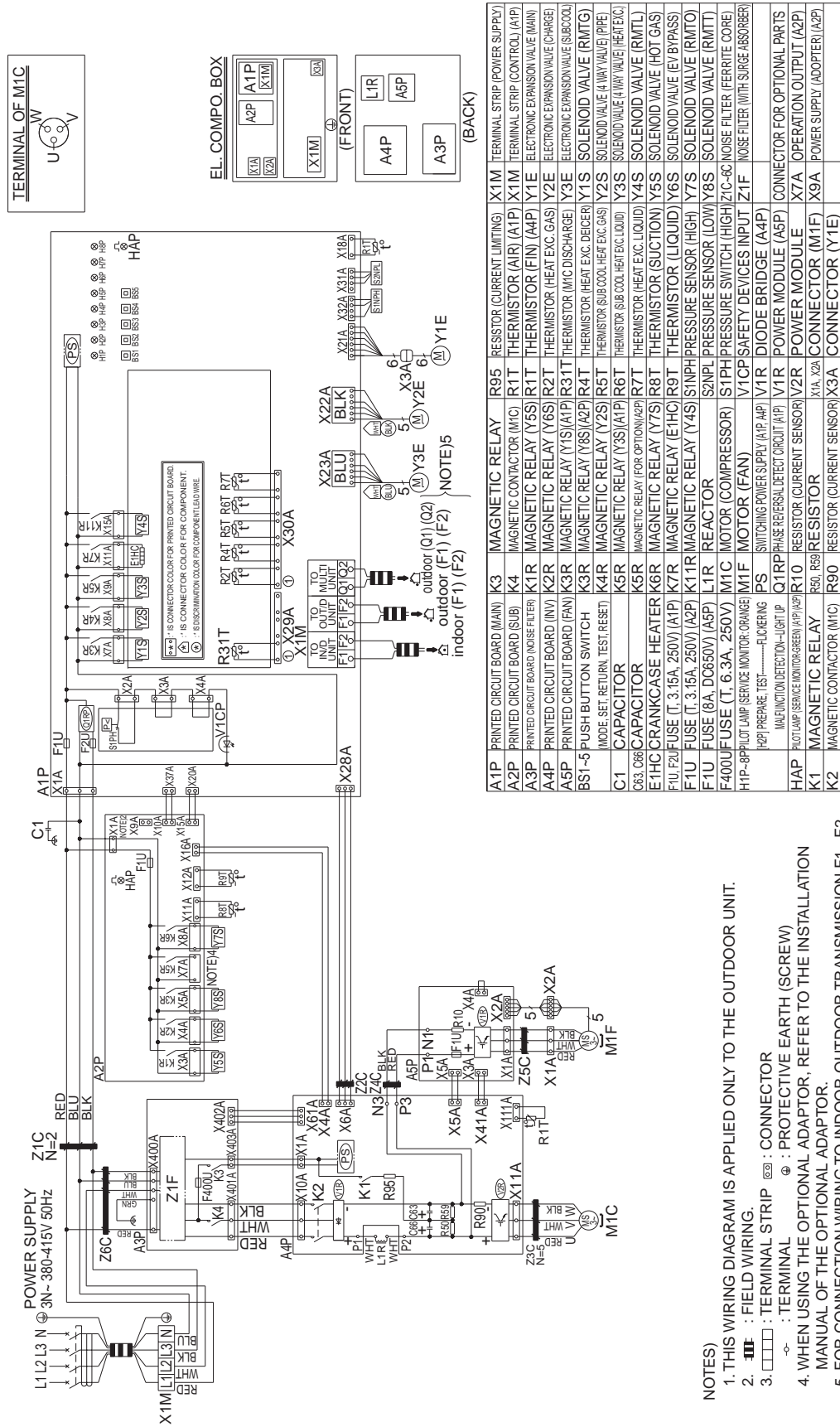

NOTES

1. THIS WIRING DIAGRAM IS APPLIED ONLY TO THE OUTDOOR UNIT.
2. ■■■ : FIELD WIRING.
3. □ : TERMINAL
⊕ : TERMINAL STRIP
⊕ : PROTECTIVE EARTH (SCREW)
4. WHEN USING THE OPTIONAL ADAPTOR, REFER TO THE INSTALLATION MANUAL OF THE OPTIONAL ADAPTOR.
5. FOR CONNECTION WIRING TO INDOOR-OUTDOOR TRANSMISSION F1 - F2, OUTDOOR-OUTDOOR TRANSMISSION F1 - F2, OUTDOOR-MULTI TRANSMISSION Q1 - Q2, REFER TO THE INSTALLATION MANUAL.
6. HOW TO USE BS1-5, REFER TO "SERVICE PRECAUTION" LABEL ON EL. COMPO. BOX COVER.
7. WHEN OPERATING, DON'T SHORTCIRCUIT THE PROTECTION DEVICE (S1PH).
8. COLORS BLK : BLACK RED : RED BLU : BLUE WHT : WHITE GRN : GREEN.

3D055307E

REMQU10P / 12P8Y1B

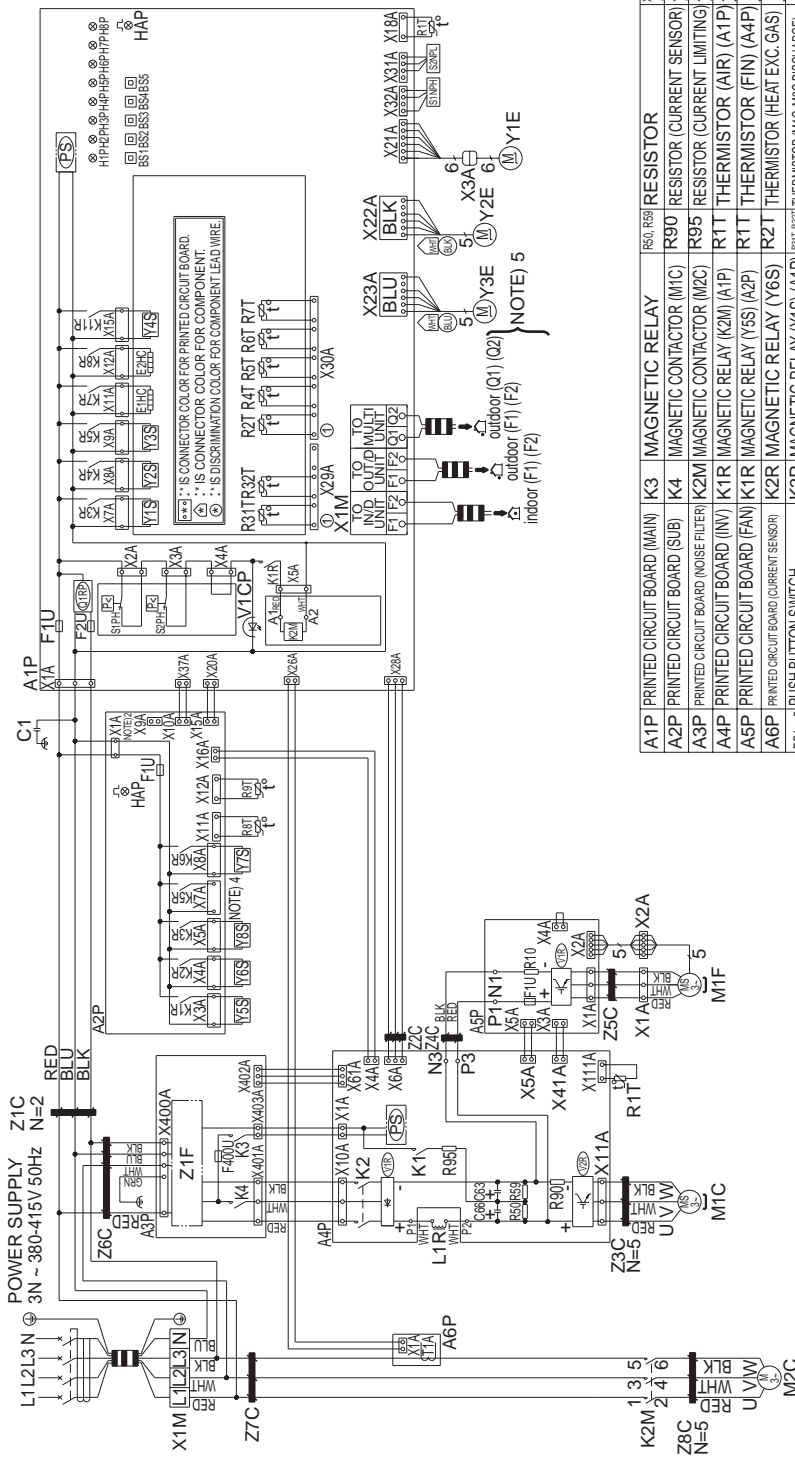
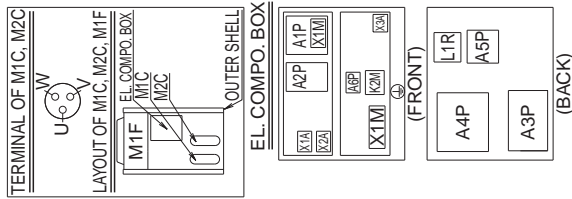

- NOTES)
1. THIS WIRING DIAGRAM IS APPLIED ONLY TO THE OUTDOOR UNIT.
 2. : FIELD WIRING.
 3. : TERMINAL STRIP : CONNECTOR : TERMINAL
 4. WHEN USING THE OPTIONAL ADAPTOR, REFER TO THE INSTALLATION MANUAL OF THE OPTIONAL ADAPTOR.
 5. FOR CONNECTION WIRING TO INDOOR-OUTDOOR TRANSMISSION F1 - F2, OUTDOOR-OUTDOOR TRANSMISSION F1 · F2, OUTDOOR-MULTI TRANSMISSION Q1 · Q2, REFER TO THE INSTALLATION MANUAL.
 6. HOW TO USE BS1 ~ 5, REFER TO "SERVICE PRECAUTION" LABEL ON EL. COMPO. BOX COVER.
 7. WHEN OPERATING, DON'T SHORTCIRCUIT THE PROTECTION DEVICE (S1PH, S2PH).
 8. COLORS BLK : BLACK RED : RED BLU : BLUE WHT : WHITE GRN : GREEN.

A1P	PRINTED CIRCUIT BOARD (MAIN)	K3	MAGNETIC RELAY	R90, R93	RESISTOR	X1A, X2A	CONNECTOR (M1F)
A2P	PRINTED CIRCUIT BOARD (SUB)	K4	MAGNETIC CONTACTOR (M1C)	R90	RESISTOR (CURRENT SENSOR)	X3A	CONNECTOR (Y1E)
A3P	PRINTED CIRCUIT BOARD (NOISE FILTER)	K2M	MAGNETIC CONTACTOR (M2C)	R95	RESISTOR (CURRENT LIMITING)	X1M	TERMINAL STRIP (POWER SUPPLY)
A4P	PRINTED CIRCUIT BOARD (INV)	K1R	MAGNETIC RELAY (K2M) (A1P)	R11	THERMISTOR (AIR) (A1P)	X1M	TERMINAL STRIP (CONTROL) (A1P)
A5P	PRINTED CIRCUIT BOARD (FAN)	K1R	MAGNETIC RELAY (Y6S) (A2P)	R11	THERMISTOR (FIN) (A4P)	Y1E	ELECTRONIC EXPANSION VALVE (MAIN)
A6P	PRINTED CIRCUIT BOARD (CURRENT SENSOR)	K2R	MAGNETIC RELAY (Y6S) (A2P)	R21	THERMISTOR (HEAT EXC. GAS)	Y2E	ELECTRONIC EXPANSION VALVE (CHARGE)
BS1 ~ 5	PUSH BUTTON SWITCH	K3R	MAGNETIC RELAY (Y1S) (A1P)	R21, R22	THERMISTOR (M1C, M2C DISCHARGE)	Y3E	ELECTRONIC EXPANSION VALVE (SUBCOOL)
C1	CAPACITOR	K3R	MAGNETIC RELAY (Y8S) (A2P)	R41	THERMISTOR (HEAT EXC. DEICER)	Y1S	SOLENOID VALVE (RMTG)
C03, C06	CAPACITOR	K4R	MAGNETIC RELAY (Y2S) (A1P)	R51	THERMISTOR (SUB-COOL-HEAT EXC. GAS)	Y2S	SOLENOID VALVE (4 WAY VALVE) (PIPE)
EHC, E3C	CRANKCASE HEATER	K5R	MAGNETIC RELAY (Y3S) (A1P)	R61	THERMISTOR (SUB-COOL-HEAT EXC. LIQUID)	Y3S	SOLENOID VALVE (4 WAY VALVE) (HEAT EXC)
F1U, F2U	FUSE (T. 3.15A, 250V) (A1P)	K6R	MAGNETIC RELAY (FOR OPTION) (A2P)	R71	THERMISTOR (HEAT EXC. LIQUID)	Y4S	SOLENOID VALVE (RMTL)
F1U	FUSE (T. 3.15A, 250V) (A2P)	K7R	MAGNETIC RELAY (E1HC)	R81	THERMISTOR (SUCTION)	Y5S	SOLENOID VALVE (HOT GAS)
F1U	FUSE (8A, DC650V) (A5P)	K8R	MAGNETIC RELAY (E2HC)	R91	THERMISTOR (LIQUID)	Y6S	SOLENOID VALVE (HOT GAS)
F400U	FUSE (T. 6.3A, 250V) (A3P)	K1R	MAGNETIC RELAY (Y4S) (A2P)	S1PH	PRESSURE SENSOR (HIGH)	Y7S	SOLENOID VALVE (EV BYPASS)
H1P, H2P	PILOT LAMP (SERVICE MONITOR) (ORANGE)	L1R	REACTOR	S2PH	PRESSURE SENSOR (LOW)	Y8S	SOLENOID VALVE (RMTT)
HAP	PILOT LAMP (SERVICE MONITOR) (GREEN) (A1P) (A2P)	M1C, M2C	MOTOR (COMPRESSOR)	T1A	CURRENT SENSOR	Z1F	NOISE FILTER (WITH SURGE ABSORBER)
K1	MAGNETIC RELAY	PS	SWITCHING POWER SUPPLY (A1P, A4P)	V1CP	SAFETY DEVICES INPUT		
K2	MAGNETIC CONTACTOR (M1C)	Q1RP	PHASE REVERSAL DETECT CIRCUIT	V1R	DIODE BRIDGE (A4P)		
		R10	RESISTOR (CURRENT SENSOR)	V1R	POWER MODULE (A5P)	X7A	CONNECTOR FOR OPTIONAL PARTS
				V2R	POWER MODULE	X9A	OPERATION OUTPUT (A2P)
							POWER SUPPLY (ADAPTER) (A2P)

3D055308E

REMQR14P / 16P8Y1B

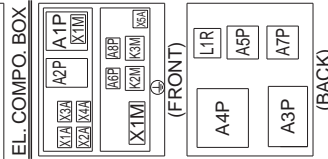
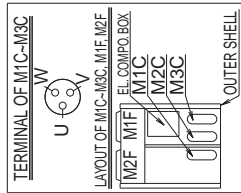
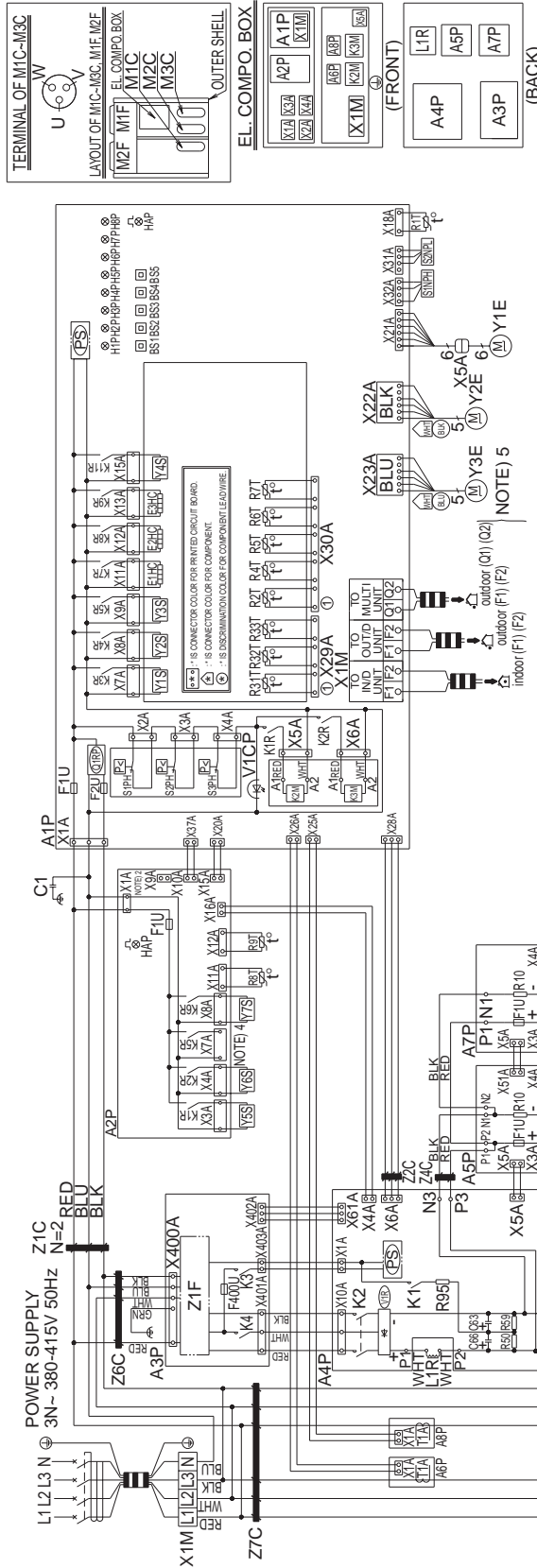

A1P	PRINTED CIRCUIT BOARD (MAIN)	K3	MAGNETIC RELAY	R50, R59	RESISTOR	X1A-4H	CONNECTOR (M1F, M2F)
A2P	PRINTED CIRCUIT BOARD (SUB)	K4	MAGNETIC CONTACTOR (M1C)	R90	RESISTOR (CURRENT SENSOR)	X5A	CONNECTOR (Y1E)
A3P	PRINTED CIRCUIT BOARD (NOISE FILTER)	K2M, K3M	MAGNETIC CONTACTOR (M2C, M3C)	R95	RESISTOR (CURRENT LIMITING)	X1M	TERMINAL STRIP (POWER SUPPLY)
A4P	PRINTED CIRCUIT BOARD (INV)	K1R, K2R	MAGNETIC RELAY (K2M, K3M) (A1P)	R1T	THERMISTOR (AIR) (A1P)	X1M	TERMINAL STRIP (CONTROL) (A1P)
A5P, A6P	PRINTED CIRCUIT BOARD (CURRENT SENSOR)	K1R	MAGNETIC RELAY (Y6S) (A2P)	R1T	THERMISTOR (FIN) (A4P)	Y1E	ELECTRONIC EXPANSION VALVE (MAIN)
BS1-5	PUSH BUTTON SWITCH (MODE, SET, RETURN, TEST, RESET)	K3R	MAGNETIC RELAY (Y1S)	R2T	THERMISTOR (HEAT EXC. GAS)	Y2E	ELECTRONIC EXPANSION VALVE (CHARGE)
C1	CAPACITOR	K4R	MAGNETIC RELAY (Y2S)	R31-35T	THERMISTOR (M1C-3C DISCHARGE)	Y3E	ELECTRONIC EXPANSION VALVE (SUBCOOL)
C2, C3, C4, C5, C6	CAPACITOR	K5R	MAGNETIC RELAY (Y3S) (A1P)	R4T	THERMISTOR (HEAT EXC. DECKER)	Y1S	SOLENOID VALVE (RMTG)
EHIC-3C	CRANKCASE HEATER	K5R	MAGNETIC RELAY (FOR OPTION) (A2P)	R5T	THERMISTOR (SUBCOOL-HEAT EXC. GAS)	Y2S	SOLENOID VALVE (AIR VALVE) (PPE)
F1U, F2U	FUSE (T. 3.15A, 250V) (A1P)	K6R	MAGNETIC RELAY (Y7S)	R6T	THERMISTOR (SUBCOOL-HEAT EXC. LIQUID)	Y3S	SOLENOID VALVE (AIR VALVE) (HEAT EXC.)
F1U	FUSE (T. 3.15A, 250V) (A2P)	K7R	MAGNETIC RELAY (E1HC)	R7T	THERMISTOR (HEAT EXC. LIQUID)	Y4S	SOLENOID VALVE (RMTL)
F1U	FUSE (6A, DC650V) (A5P, A7P)	K8R	MAGNETIC RELAY (E2HC)	R8T	THERMISTOR (SUCTION)	Y5S	SOLENOID VALVE (HOT GAS)
F400U	FUSE (T. 6.3A, 250V) (A3P)	K9R	MAGNETIC RELAY (E3HC)	R9T	THERMISTOR (LIQUID)	Y6S	SOLENOID VALVE (EV BYPASS)
H1P-3P	PILOT LAMP (SERVICE MONITOR, ORANGE)	K11R	MAGNETIC RELAY (Y4S)	SN1P	PRESSURE SENSOR (HIGH)	Y7S	SOLENOID VALVE (RMTO)
HAP	PILOT LAMP (SERVICE MONITOR, GREEN)	L1R	REACTOR	SPH-3PH	PRESSURE SENSOR (LOW)	Z1C-10C	NOISE FILTER (FERRITE CORE)
K1	MAGNETIC RELAY	M1C-3C	MOTOR (COMPRESSOR)	T1A	CURRENT SENSOR (A8P, A8P)	Z1F	NOISE FILTER (WITH SURGE ABSORBER)
K2	MAGNETIC CONTACTOR (M1C)	V1CP	MOTOR (FAN)	V1CP	SAFETY DEVICES INPUT		CONNECTOR FOR OPTIONAL PARTS
		PS	SWITCHING POWER SUPPLY (A1P, A4P)	Q1RP	DIODE BRIDGE (A4P)	X7A	OPERATION OUTPUT (A2P)
		Q1RP	PHASE REVERSAL DETECT CIRCUIT	V1R	POWER MODULE (A5P, A7P)	X9A	POWER SUPPLY (ADAPTER) (A2P)
		R10	RESISTOR (CURRENT SENSOR) (A5P, A7P)	V2R	POWER MODULE		

- NOTES)
- THIS WIRING DIAGRAM IS APPLIED ONLY TO THE OUTDOOR UNIT.
 - FIELD WIRING.
 - CONNECTOR (SCREW) : TERMINAL
 - WHEN USING THE OPTIONAL ADAPTOR, REFER TO THE INSTALLATION MANUAL OF THE OPTIONAL ADAPTOR.
 - FOR CONNECTION WIRING TO INDOOR-OUTDOOR TRANSMISSION F1 · F2, OUTDOOR-OUTDOOR TRANSMISSION F1 · F2, OUTDOOR-MULTI TRANSMISSION Q1 · Q2, REFER TO THE INSTALLATION MANUAL.
 - HOW TO USE BS1-5, REFER TO "SERVICE PRECAUTION" LABEL ON EL. COMPO. BOX COVER.
 - WHEN OPERATING, DON'T SHORT/CIRCUIT THE PROTECTION DEVICE (S1-3PH).
 - COLORS BLK : BLACK RED : RED BLU : BLUE WHT : WHITE GRN : GREEN.

3D055309E

2.2 Field Wiring

REYQ8P / 10P / 12P / 14P / 16P8Y1B

- 6) Unit shall be grounded in compliance with the applicable local and national codes.
 - 7) Wiring shown are general points-of-connection guides only and are not intended for or to include all details for a specific installation.
 - 8) Be sure to install the switch that can interrupt all the power line of each equipment.
 - 9) Install the main switch that can interrupt all the power sources in an integrated manner because this system consists of the equipment utilizing the multiple power sources.
 - 10) If there exists the possibility of reversed phase, lose phase, momentary blackout or the power goes on and off while the product is operating, attach a reversed phase protection circuit locally.
- Running the product in rversed phase may break the compressor and other parts.

- NOTES
- 1) All wiring, components and materials to be procured on the site must comply with the applicable local and national codes.
 - 2) Use copper conductors only.
 - 3) As for details, see wiring diagram.
 - 4) Install circuit breaker for safety.
 - 5) All field wiring and components must be provided by licensed electrician.

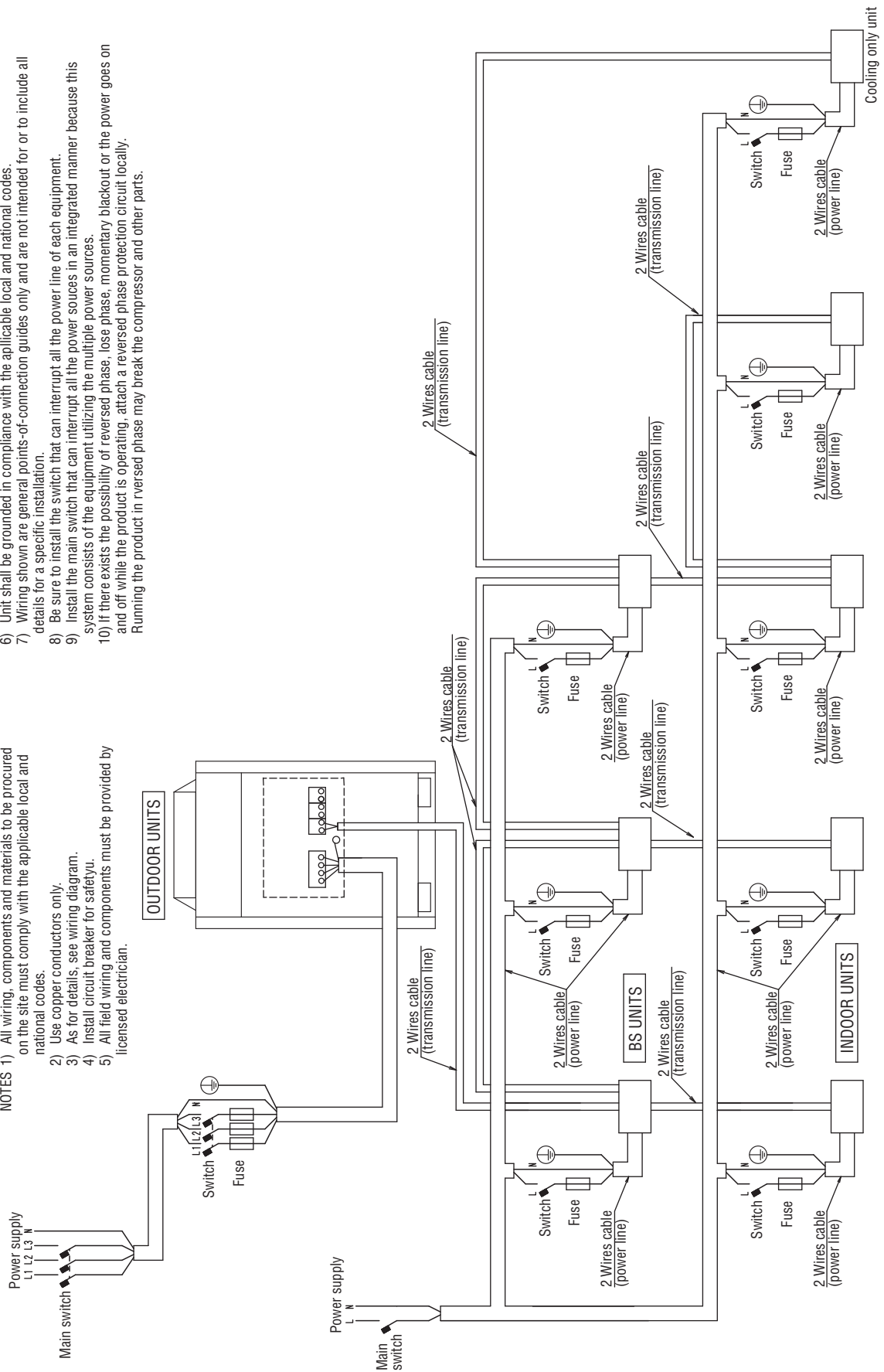

3D057764A

REYQ18P / 20P / 22P / 24P / 26P / 28P / 30P / 32P8Y1B

- NOTES**
- 1) All wiring, components and materials to be procured on the site must comply with the applicable local and national codes.
 - 2) Use copper conductors only.
 - 3) As for details, see wiring diagram.
 - 4) Install circuit breaker for safety.
 - 5) All field wiring and components must be provided by licensed electrician.

- 6) Unit shall be grounded in compliance with the applicable local and national codes.
- 7) Wiring shown are general points-of-connection guides only and are not intended for or to include all details for a specific installation.
- 8) Be sure to install the switch and the fuse to the power line of each equipment.
- 9) Install the main switch that can interrupt all the power sources in an integrated manner because this system consists of the equipment utilizing the multiple power sources.
- 10) The capacity of UNIT1 must be larger than UNIT2 when the power source is connected in series between the units.
- 11) If there exists the possibility of reversed phase, lose phase, momentary blackout or the power goes on and off while the product is operating, attach a reversed phase protection circuit locally. Running the product in reversed phase may break the compressor and other parts.

When the power source is supplied to each outdoor unit individually

When the power source is connected in series between the units

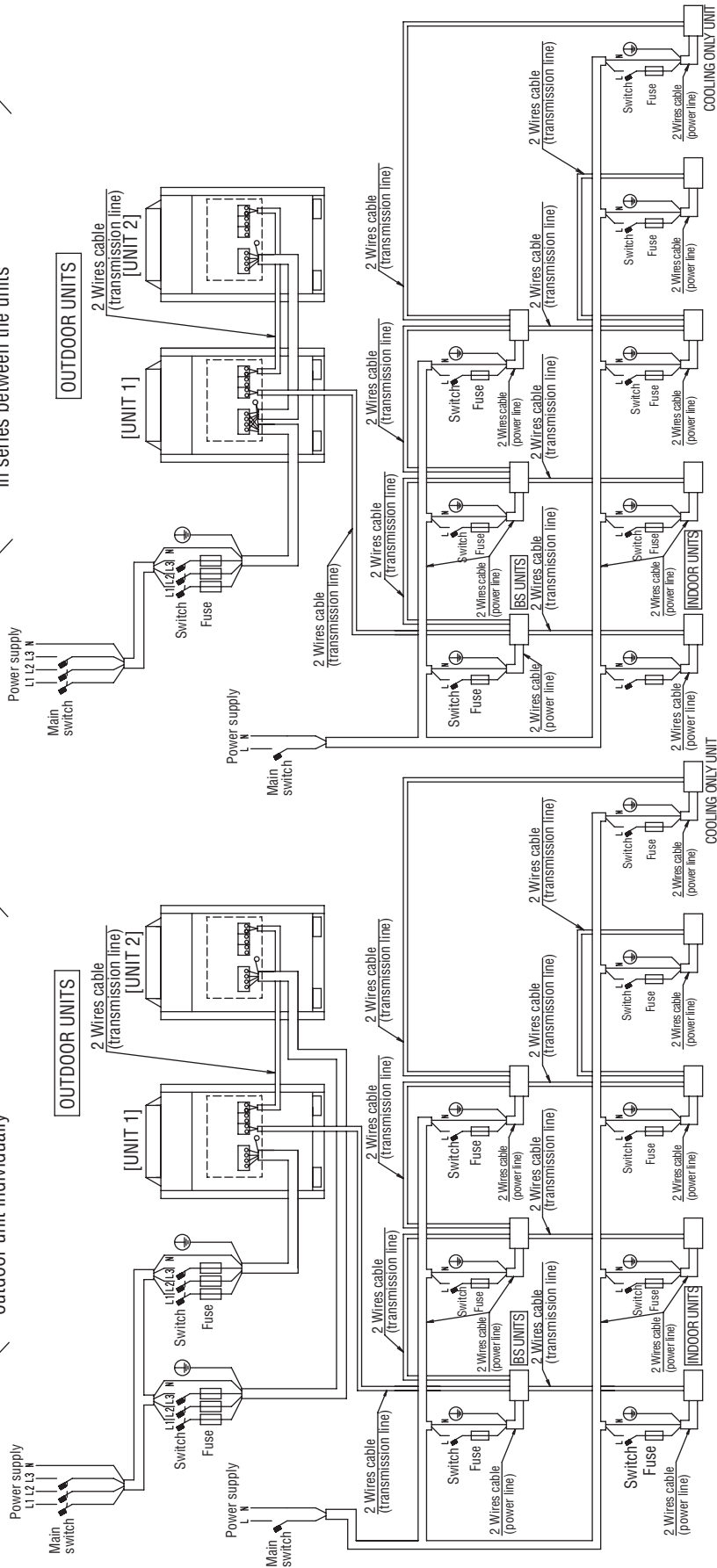

3D057762

REYQ34P / 36P / 38P / 40P / 42P / 44P / 46P / 48P8Y1B

- NOTES
- 1) All wiring, components and materials to be procured on the site must comply with the applicable local and national codes.
 - 2) Use copper conductors only.
 - 3) As for details, see wiring diagram.
 - 4) Install circuit breaker for safety.
 - 5) All field wiring and components must be provided by licensed electrician.

- 6) Unit shall be grounded in compliance with the applicable local and national codes.
- 7) Wiring shown are general points-of-connection guides only and are not intended for or to include all details for a specific installation.
- 8) Be sure to install the switch and the fuse to the power line of each equipment.
- 9) Install the main switch that can interrupt all the power sources in an integrated manner because this system consists of the equipment utilizing the multiple power sources.
- 10) The capacity of UNIT1 must be larger than UNIT2 when the power source is connected in series between the units.
- 11) If there exists the possibility of reversed phase, lose phase, momentary blackout or the power goes on and off while the product is operating, attach a reversed phase protection circuit locally. Running the product in reversed phase may break the compressor and other parts.

When the power source is supplied to each outdoor unit individually

When the power source is connected in series between the units

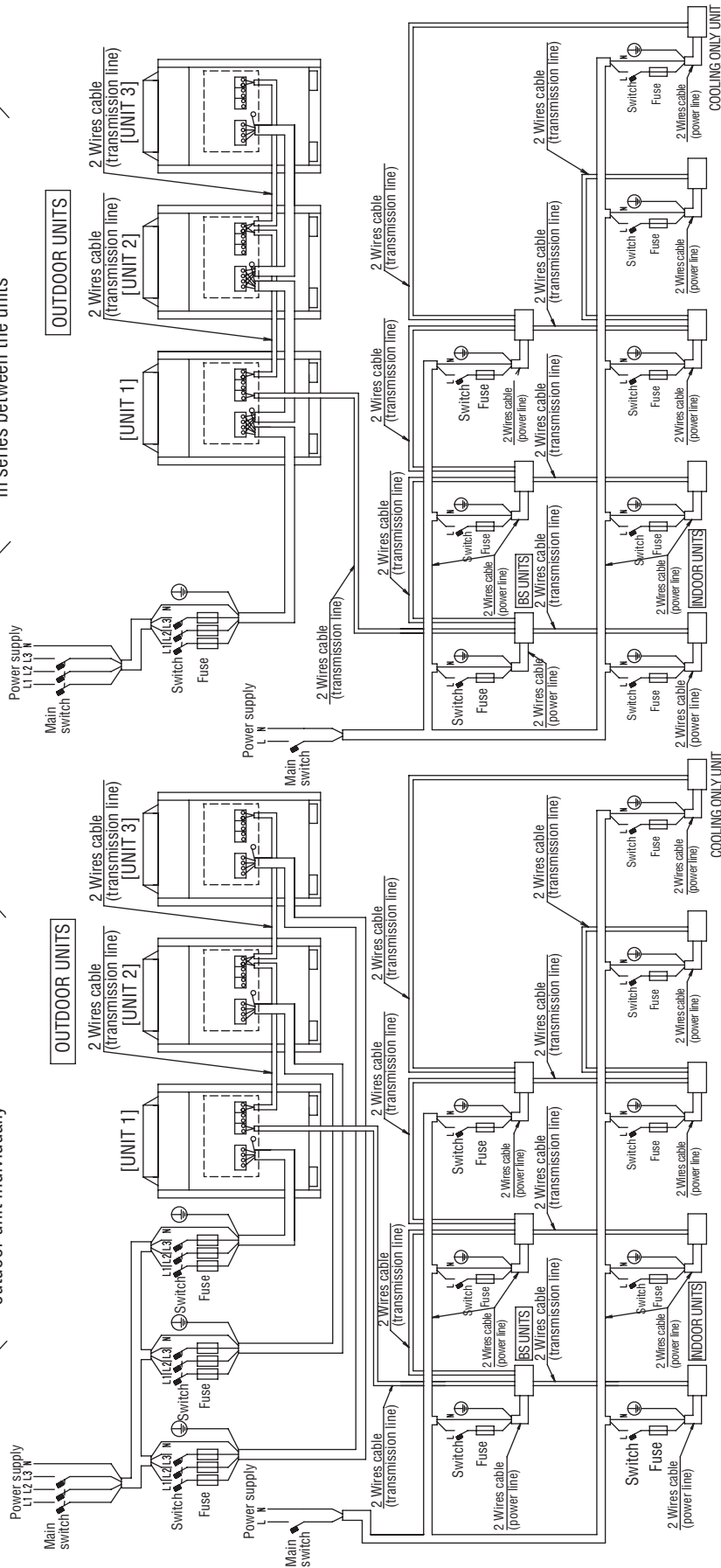

3D057763

FXZQ20M / 25M / 32M / 40M / 50MV1

20,25,32,40,50 class
(22,28,36,45,56 class)

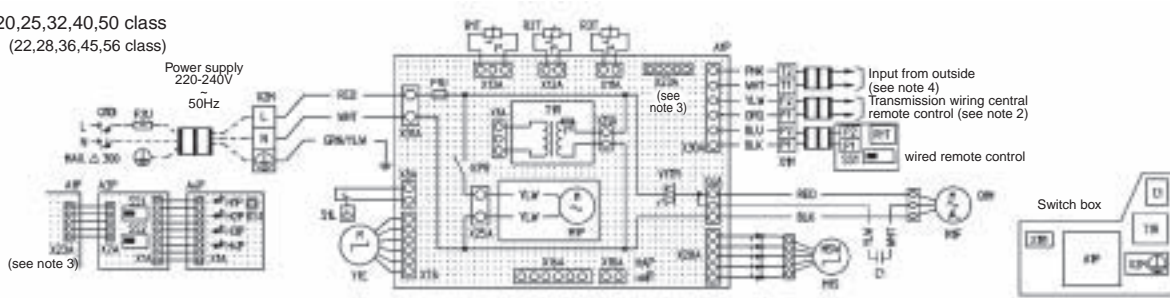

A1P	Printed circuit board	T1R	Transformer (220-240/22V)	H3P	Light emitting diode (Filter sign-red)
C1	Capacitor (M1F)	V1TR	Triac	H4P	Light emitting diode (defrost-orange)
F1U	Fuse (B , 5A, 250V)	X1M	Terminal strip	SS1	Selector switch (main/sub)
F2U	Field fuse	X2M	Terminal strip	SS2	Selector switch (wireless address set)
HAP	Light emitting diode (service monitor green)	Y1E	Electronic expansion valve		connector for optional parts
KPR	Magnetic relay (M1P)	R1T	Thermistor	X16A	Connector (adapter for wire)
M1F	Motor (indoor fan)	SS1	Selector switch (main/sub)	X18A	Connector (on/off) (wiring adapter for electrical appendices)
M1P	Motor (drain pump)		Infrared remote control (receiver/display unit)		
M1S	Motor (swing flap)	A3P	Printed circuit board		
Q1DI	Field earth leak detector (max. 300mA)	A4P	Printed circuit board		
Q1M	Thermal protector (M1F embedded)	BS1	Push button (on/off)		
R1T	Thermistor (Air)	H1P	Light emitting diode (On-red)		
R2T	Thermistor (Coil-Liquid)	H2P	Light emitting diode (Timer-green)		
R3T	Thermistor (Coil-Gas)				
S1L	Float switch				

- : Terminal
- ⊞ : Connector
- ⚡ : Wire clamp
- ≡ : Field wiring

NOTES

1. In case of using a central remote control, connect it to the unit in accordance to the attached installation manual.
2. X23A is connected when the infrared remote control kit is being used.
3. When connecting the input wires from outside, forced off or on/off control operation can be selected by the remote control. In details, refer to the installation manual attached to the unit.
4. Remote control model varies according to the combination system. See technical data and catalogs, etc. before connecting.

3TW28836-1B

FXCQ20M / 25M / 32M / 63MV3

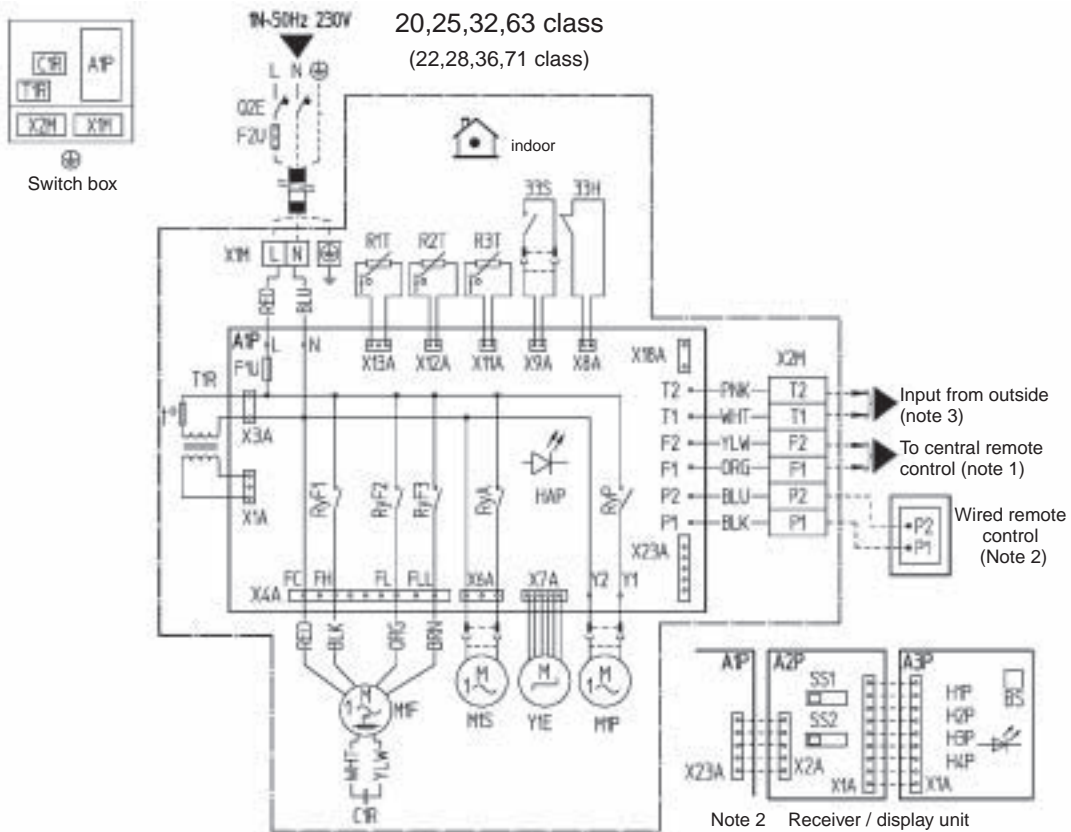

--- Field wiring

L : Live
 N : Neutral
 ⊕ : Protective earth (screw)

⊠ : Connector
 ○ : Wire clamp

Colors
 BLK : BLACK
 BLU : BLUE
 BRN : BROWN
 ORG : ORANGE
 PNK : PINK
 RED : RED
 WHT : WHITE
 YLW : YELLOW

33H	Float switch	R2T, R3T	Thermistor (coil)	H1P	Light emitting diode (on-red)
33S	Limit switch (swing flap)	Q2E	Earth leak detector	H2P	Light emitting diode (timer-green)
A1P	Printed circuit board	RyA	Magnetic relay (M1S)	H3P	Light emitting diode (filter sign-red)
C1R	Capacitor (M1F)	RyF1-3	Magnetic relay (M1F)	H4P	Light emitting diode (defrost-orange)
F1T	Thermal fuse (152°C) (M1F embedded)	RyP	Magnetic relay (M1P)	SS1	Selector switch (main/sub)
F1U	Fuse (250V, 5A)	T1R	Transformer (220-240V/22V)	SS2	Selector switch (wireless address set)
F2U	Field fuse	X1M	Terminal strip (power)	Connector for optional parts	
HAP	Light emitting diode (service monitor-green)	X2M	Terminal strip (control)	X18A	Connector (wiring, adapter for electrical appendices)
M1F	Motor (indoor fan)	Y1E	Electronic expansion valve	X23A	Connector (infrared remote control)
M1S	Motor (swing flap)	Receiver / display unit (attached to infrared remote control)			
M1P	Motor (drain pump)	A2P, A3P	Printed circuit board		
R1T	Thermistor (air)	BS	On/off button		

NOTES

- When using a central remote control, see manual for connection to the unit.
- X23A is connected when the infrared remote control kit is used.
- When connecting the input wires from outside, "forced off" or "on/off" control operation can be selected by the remote control. For more details see installation manual.
- Use copper conductors only.

2TW23776-1D

FXCQ40M / 50M / 80M / 125MV3

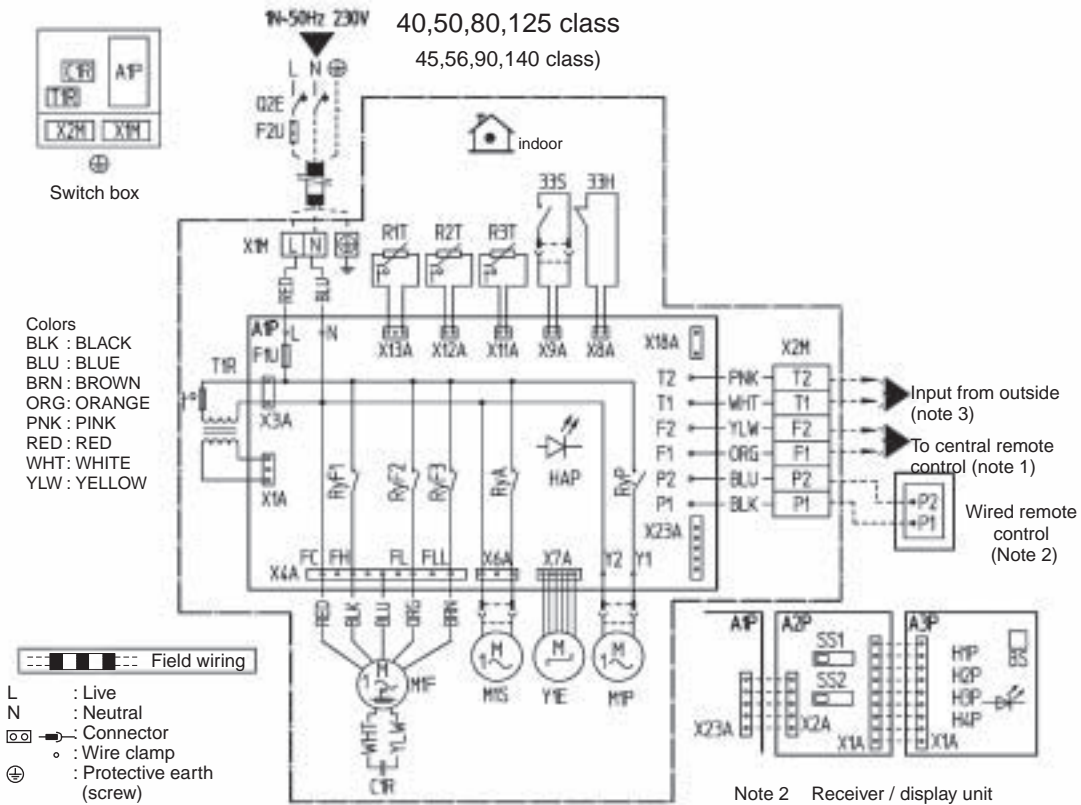

33H	Float switch	R2T, R3T	Thermistor (coil)	H1P	Light emitting diode (on-red)
33S	Limit switch (swing flap)	Q2E	Earth leak detector	H2P	Light emitting diode (timer-green)
A1P	Printed circuit board	RyA	Magnetic relay (M1S)	H3P	Light emitting diode (filter sign-red)
C1R	Capacitor (M1F)	RyF1-3	Magnetic relay (M1F)	H4P	Light emitting diode (defrost-orange)
F1T	Thermal fuse (152°C) (M1F embedded)	RyP	Magnetic relay (M1P)	SS1	Selector switch (main/sub)
F1U	Fuse (250V, 5A)	T1R	Transformer (220-240V/22V)	SS2	Selector switch (wireless address set)
F2U	Field fuse	X1M	Terminal strip (power)		Connector for optional parts
HAP	Light emitting diode (service monitor-green)	X2M	Terminal strip (control)	X18A	Connector (wiring, adapter for electrical appendices)
M1F	Motor (indoor fan)	Y1E	Electronic expansion valve	X23A	Connector (infrared remote control)
M1S	Motor (swing flap)	Receiver / display unit (attached to infrared remote control)			
M1P	Motor (drain pump)	A2P, A3P	Printed circuit board		
R1T	Thermistor (air)	BS	On/off button		

NOTES

- When using a central remote control, see manual for connection to the unit.
- X23A is connected when the infrared remote control kit is used.
- When connecting the input wires from outdoor, "forced off" or "on/off" control operation can be selected by the remote control.
For more details see installation manual.

2TW23806-1D

FXKQ25MA / 32MA / 40MA / 63MAVE

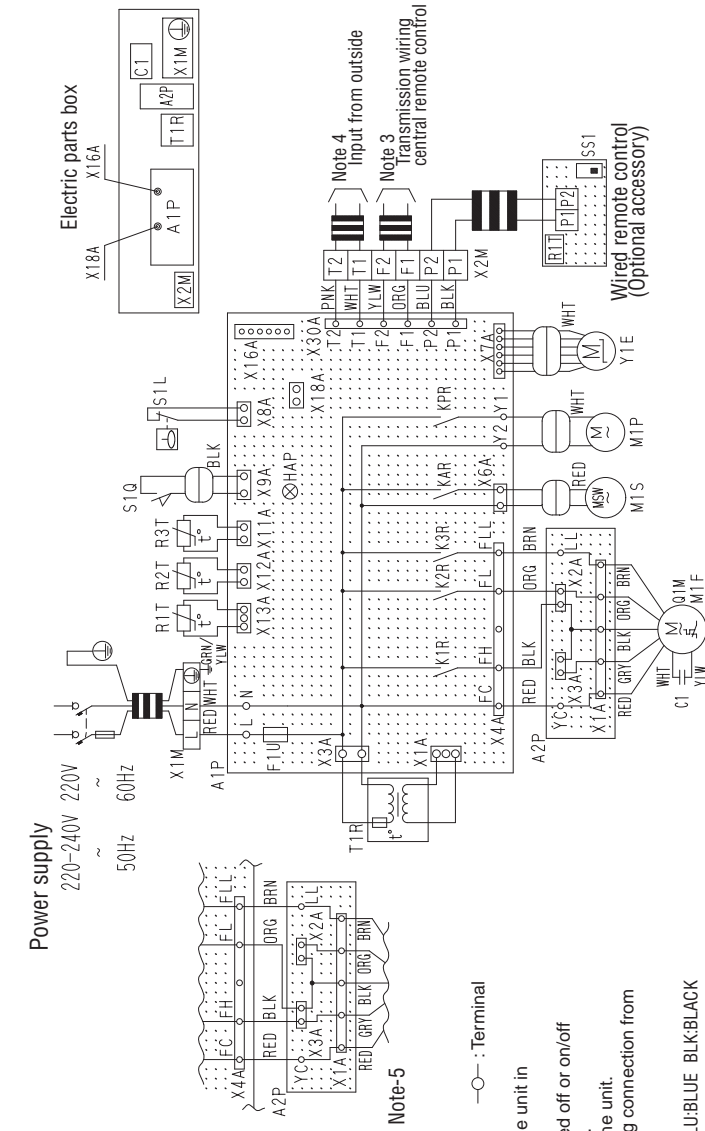

Power supply
220-240V 220V
50Hz 60Hz

Note-5

INDOOR UNIT	
A1P	Thermistor (Air)
R2T/R3T	Thermistor (Coil)
A2P	Terminal block
C1	Capacitor (M1F)
F1U	Fuse (5A, 250V)
HAP	Light emitting diode (service monitor-green)
K1R-K3R	Magnetic relay (M1S)
KAR	Magnetic relay (M1P)
KPR	Magnetic relay (M1F)
M1F	Motor (Indoor fan)
M1P	Motor (Drain pump)
M1S	Motor (Swing flap)
Q1M	Thermo switch (M1F embedded)
R1T	Thermistor (Air)
SS1	Selector switch (Main/Sub)
CONNECTOR FOR OPTIONAL PARTS	
X16A	Connector (Adapter for wiring)
X18A	Connector (Wiring adapter for electrical appliances)

- NOTES
- Terminal block
 - Field wiring
 - In case using central remote control, connect it to the unit in accordance with the attached instruction manual.
 - When connecting the input wires from outside, forced off or on/off control operation can be selected by remote control. In details, refer to the installation manual attached the unit.
 - In case high E.S.P. operation, change over the wiring connection from X2A to X3A.
 - Symbols shows as follows:
 PINK:PINK WHT:WHITE YLW:YELLOW ORG:ORANGE BLU:BLUE BLK:BLACK
 RED:RED BRN:BROWN GRY:GRAY
 - Use copper conductors only

3D039564C

FXSQ20M / 25M / 32M / 40M / 50M / 63MV3

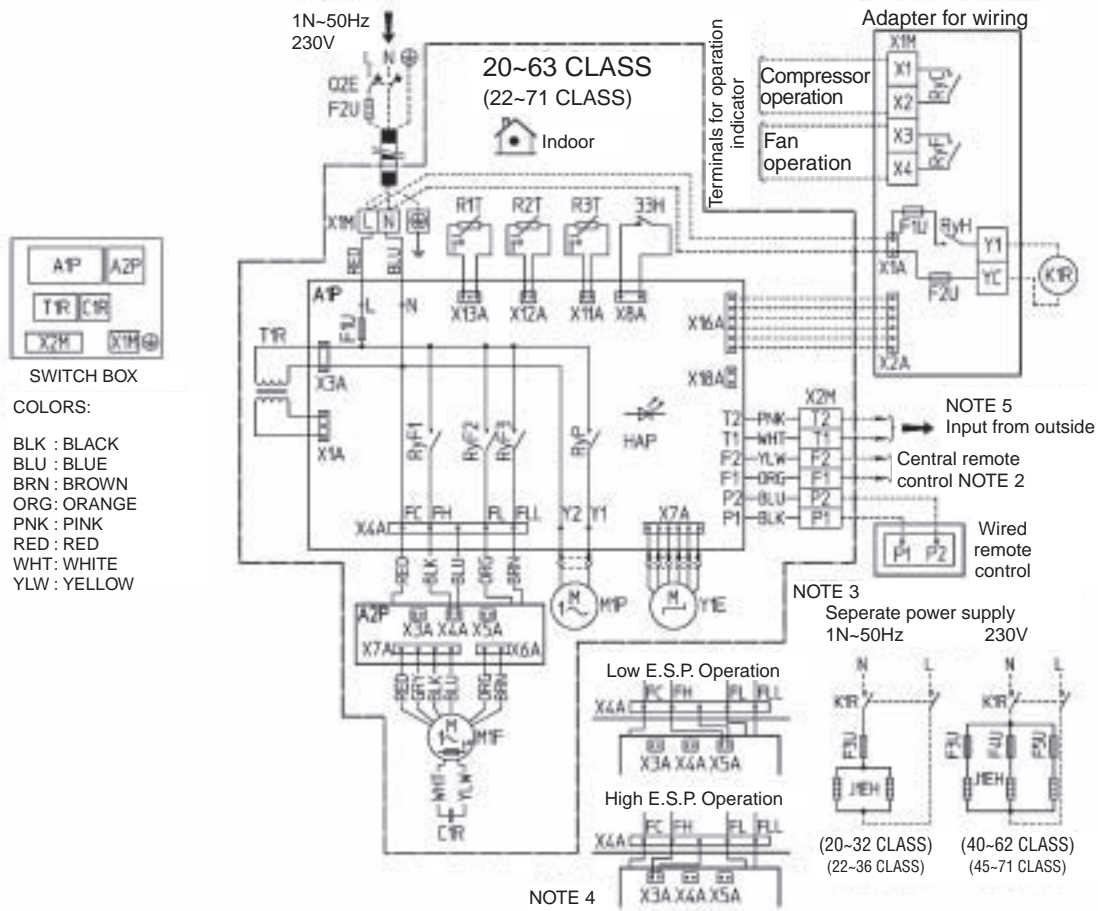

33H	Float switch	R1T	Thermistor (air)	K1R	Magnetic relay (J1EH)
A1P	Printed circuit board	R2T,R3T	Thermistor (refrigerant)	Adapter for wiring	
A2P	Therminal board	RyF1-3	Magnetic relay (Fan)	RyC,RyF	Magnetic relay
C1R	Capacitor (M1F)	RyP	Magnetic relay (Drain pump)	RyH	Magnetic relay (J1EH)
F1U	Fuse (250V, 5A)	T1R	Transformer (220V-27V)	F1U,F2U	Fuse (250V,5A)
F2U	Field fuse	X1M	Terminal strip (power)	X1A,X2A	Connector (wiring adapter)
HAP	Light emitting diode (service monitor-green)	X2M	Terminal strip (control)	X1M	Terminal strip
M1F	Motor (fan)	Y1E	Electronic expansion valve	Connector for optional parts	
M1P	Motor (drain pump)	Optional parts		X16A	Connector (wiring adapter)
Q2E	Earth leak detector	F3-5U	Fuse (250V, 16A)	X18A	Connector (wiring adapter for electrical appencices)
		J1EH	Electric heater		

- Field wiring**
- L : Live
 - N : Neutral
 - : Connector
 - : Wire clamp
 - ⊕ : Protective earth (screw)

NOTES

1. Use copper conductors only.
2. When using a central remote control, see manual for connection to the unit.
3. When installing the electric heater, change the wiring for the heater circuit. The main power supply has to be supplied independently.
4. For high E.S.P. operation, change the wiring connection of x4A as shown on the wiring diagram.
5. When connecting the input wires from outside, "forced off" or "on/off" control operation can be selected by the remote control. See installation manual for morre details.

2TW23686-1C

FXSQ80M / 100M / 125MV3

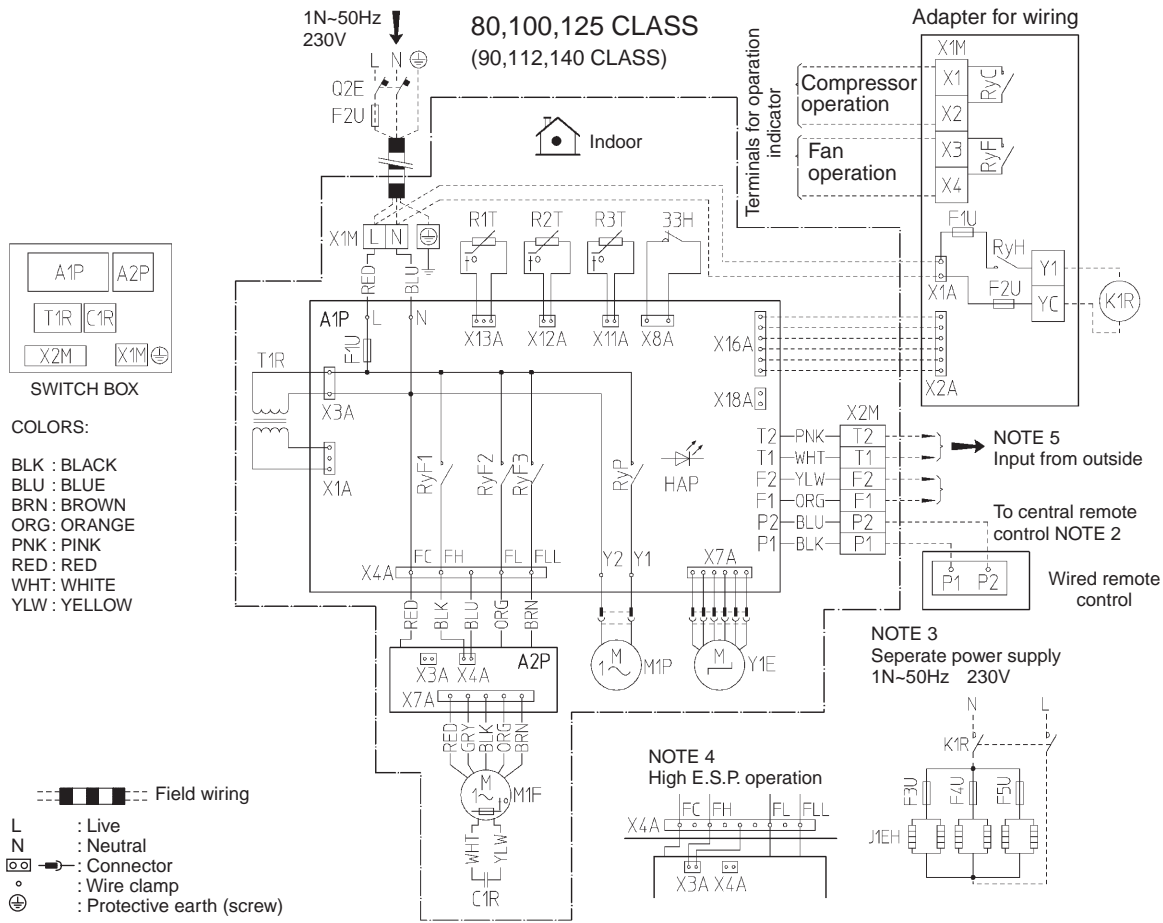

33H	Float switch	R2T, R3T	Thermistor (refrigerant)		Adapter for wiring
A1P	Printed circuit board	RyF1-3	Magnetic relay (Fan)	RyC, RyF	Magnetic relay
A2P	Therminal board	RyP	Magnetic relay (Drain pump)	RyH	Magnetic relay (J1EH)
C1R	Capacitor (M1F)	T1R	Transformer (220V-27V)	F1U, F2U	Fuse (250V, 5A)
F1U	Fuse (250V, 5A)	X1M	Terminal strip (power)	X1A, X2A	Connector (wiring adaptor)
F2U	Field fuse	X2M	Terminal strip (control)	X1M	Terminal strip
HAP	Light emitting diode (service monitor-green)	Y1E	Electronic expansion valve		Connector for optional parts
M1F	Motor (fan)		Optional parts	X16A	Connector (wiring adapter)
M1P	Motor (drain pump)	F3-5U	Fuse (250V, 16A)	X18A	Connector (wiring adapter for electronical appendices)
Q2E	Earth leak detector	J1EH	Electric heater		
R1T	Thermistor (air)	K1R	Magnetic relay (J1EH)		

NOTES

1. Use copper conductors only.
2. When using a central remote control, see manual for connection to the unit.
3. When installing the electric heater, change the wiring for the heater circuit. The main power supply has to be supplied independently.
4. For high E.S.P. operation, change the wiring connection of x4A as shown on the wiring diagram.
5. When connecting the input wires from outside, "forced off" or "on/off" control operation can be selected by the remote control. See installation manual for more details.

2TW23776-1D

FXMQ40MA / 50MA / 63MA / 80MA / 100MA / 125MAVE

3D039620B

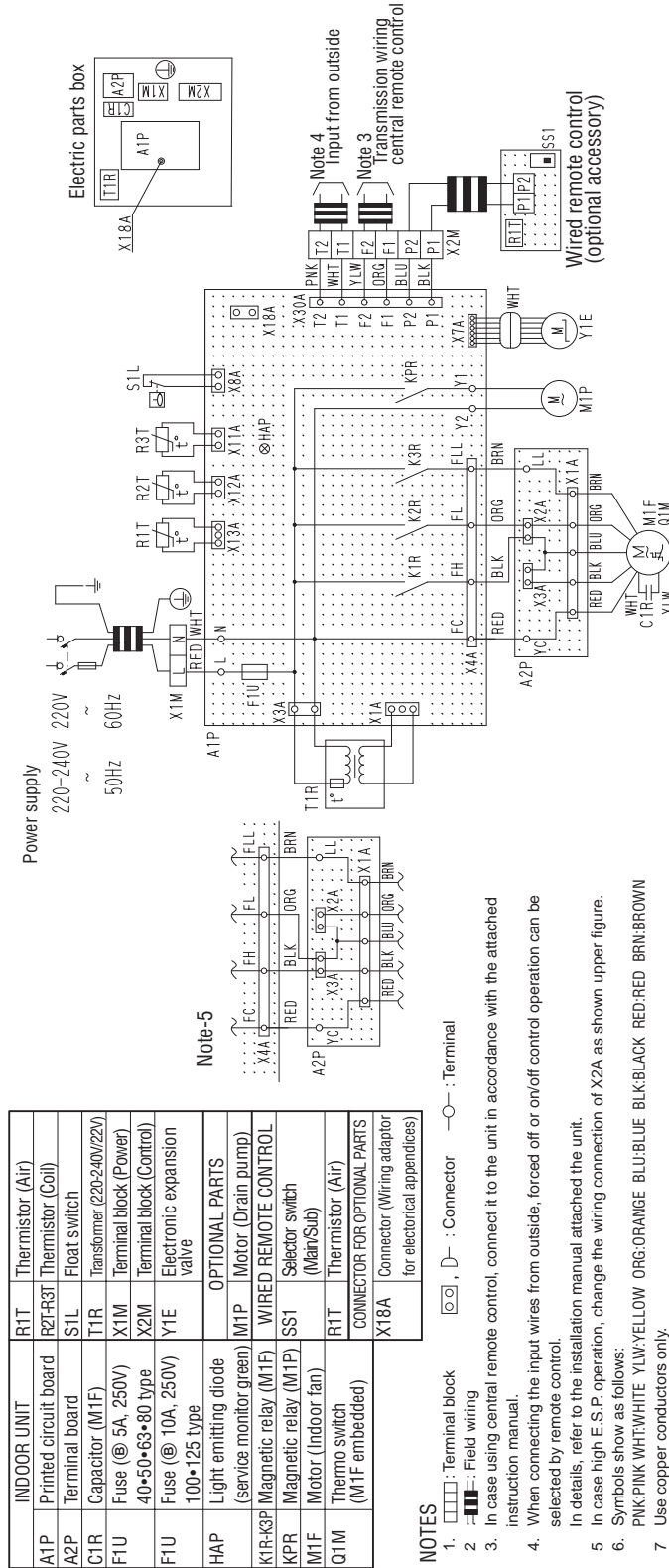

INDOOR UNIT	RT	Thermistor (Air)
A1P	Printed circuit board	Thermistor (Coil)
A2P	R2T-R3T	Thermistor (Coil)
C1R	S1L	Float switch
F1U	T1R	Transformer (220-240V/22V)
F1U	X1M	Fuse (5A, 250V)
F1U	X2M	Terminal block (Power)
F1U	Y1E	Terminal block (Control)
HAP		Electronic expansion valve
		OPTIONAL PARTS
K1R-K3P	M1P	Motor (Drain pump)
M1F	W1R	Wired Remote Control
Q1M	SS1	Selector switch (Main/Sub)
	R1T	Thermistor (Air)
	X18A	Connector (Wiring adaptor for electrical appendices)

FXMQ200MA / 250MAVE

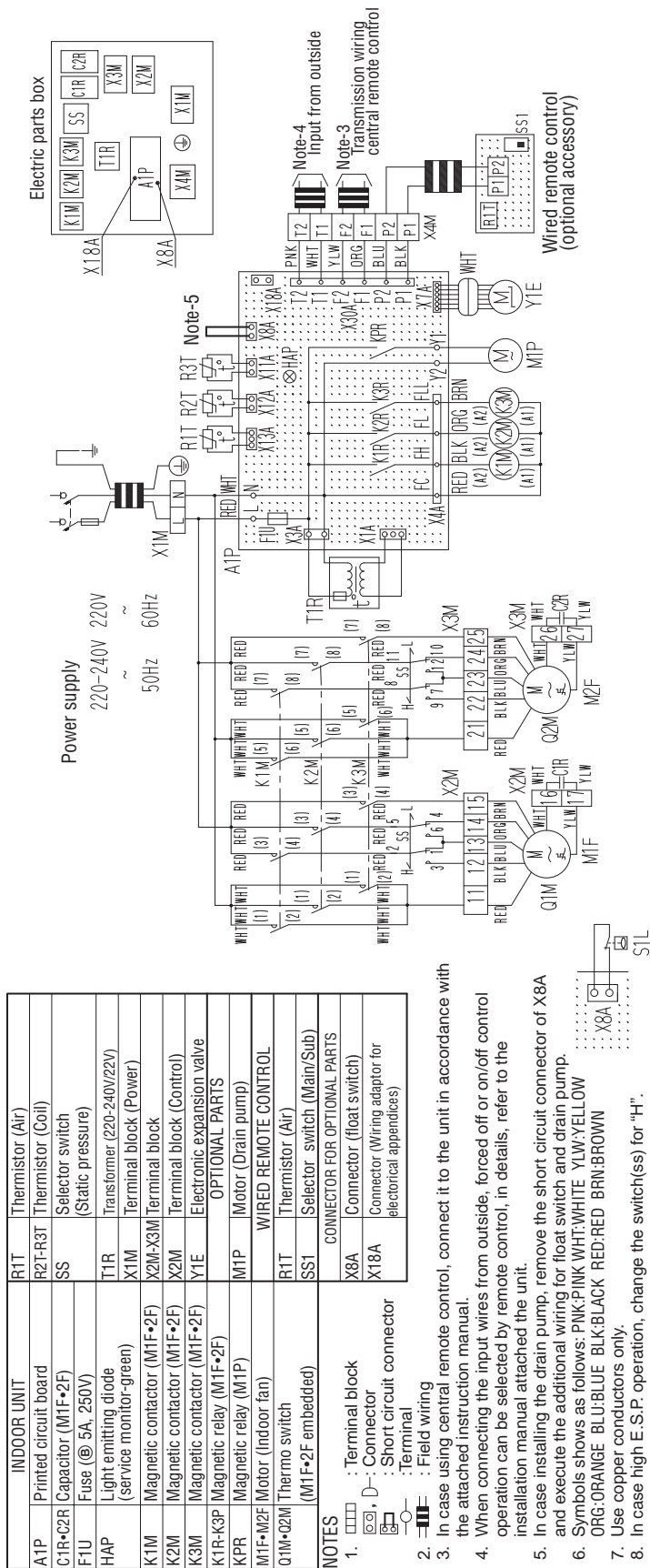

3D039621B

FXAQ20MA / 25MA / 32MAVE / 40MA / 50MA / 63MAVE

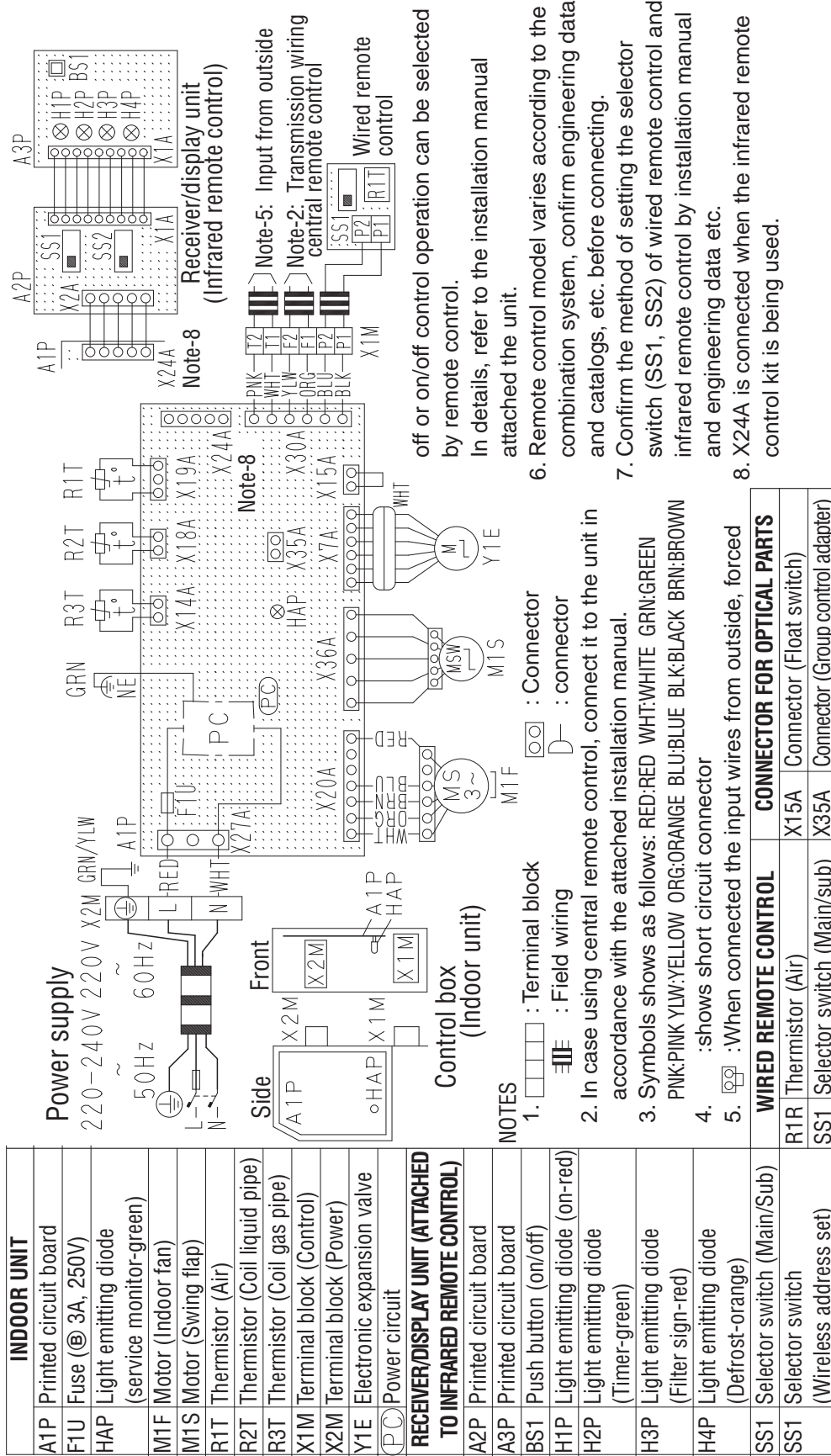

3D034206D

FXLQ20MA / 25MA / 32MA / 40MA / 50MA / 63MAVE
FXNQ20MA / 25MA / 32MA / 40MA / 50MA / 63MAVE

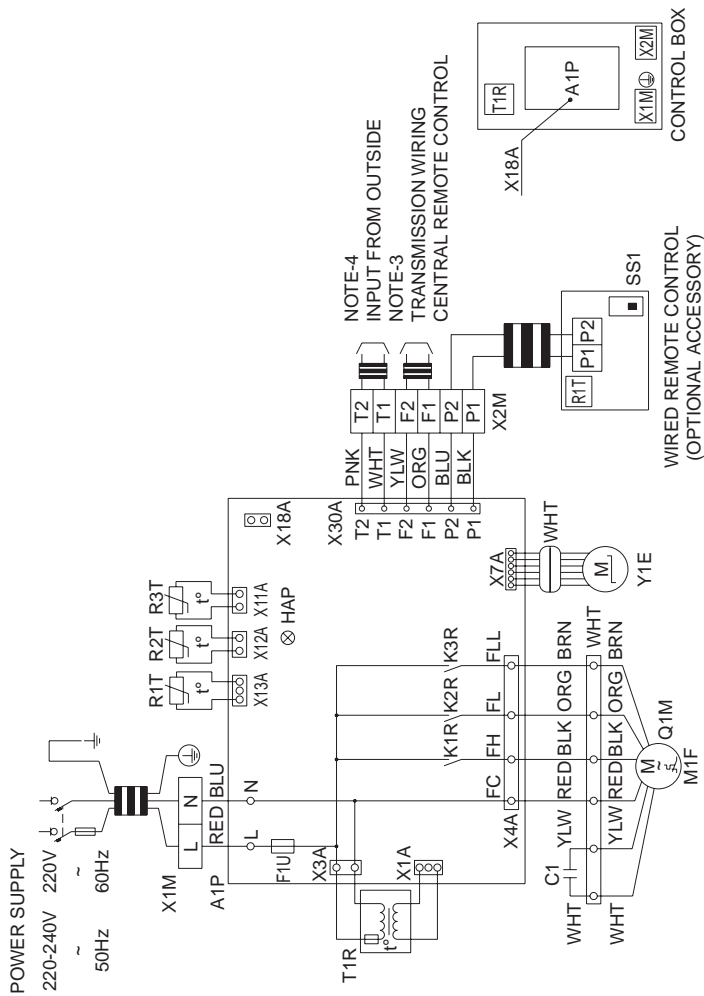

NOTE-4
INPUT FROM OUTSIDE

NOTE-3
TRANSMISSION WIRING
CENTRAL REMOTE CONTROL

CONTROL BOX

Wired Remote Control (Optional Accessory)

NOTES

1. □□□□ : TERMINAL BLOCK, □□□ : CONNECTOR, -○- : TERMINAL
2. —|—|—| : FIELD WIRING
3. IN CASE USING CENTRAL REMOTE CONTROL, CONNECT IT TO THE UNIT IN ACCORDANCE WITH THE ATTACHED INSTRUCTION MANUAL.
4. WHEN CONNECTING THE INPUT WIRES FROM OUTSIDE, FORCED OFF OR ON/OFF CONTROL OPERATION CAN BE SELECTED BY REMOTE CONTROL. IN DETAILS, REFER TO THE INSTALLATION MANUAL ATTACHED THE UNIT.
5. SYMBOLS SHOW AS FOLLOWS. (PNK : PINK WHT : WHITE YLW : YELLOW ORG : ORANGE BLU : BLUE BLK : BLACK RED : RED BRN : BROWN)
6. USE COPPER CONDUCTORS ONLY.

INDOOR UNIT	X2M	TERMINAL BLOCK (CONTROL)
A1P	Y1E	ELECTRONIC EXPANSION VALVE
C1		Wired Remote Control
F1U	R1T	THERMISTOR (AIR)
HAP	SS1	SELECTOR SWITCH (MAIN/SUB)
K1R-K3R	X18A	CONNECTOR FOR OPTIONAL PARTS
M1F		CONNECTOR (WIRING ADAPTER FOR ELECTRICAL APPENDICES)
Q1M		MOTOR (INDOOR FAN)
R1T		THERMO SWITCH (M1F EMBEDDED)
R2T-R3T		THERMISTOR (AIR)
T1R		THERMISTOR (COIL)
X1M		TRANSFORMER (220-240V/22V)
		TERMINAL BLOCK (POWER)

3D039826D

FXUQ71MA / 100MA / 125MAV1

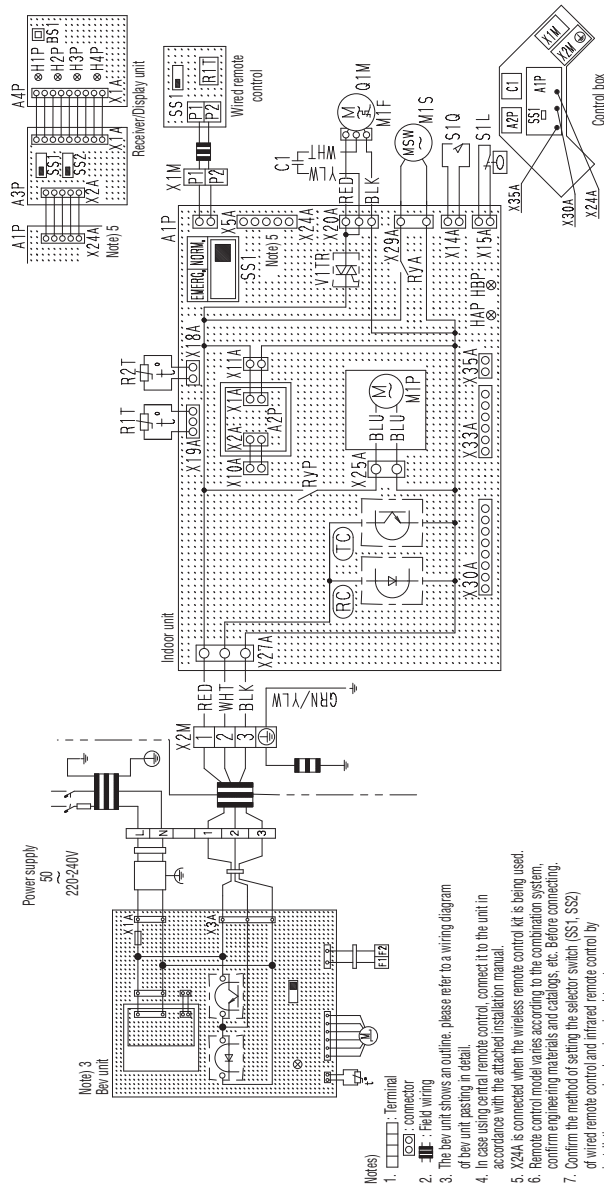

3D044973A

Indoor unit		Wired remote control	
A1P	Printed circuit board	RIT	Thermistor (Air)
A2P	Printed circuit board (Transformer 220-240V/16V)	SS1	Selector switch (Main/sub)
C1	Capacitor (MIF)	Receiver/Display unit (attached to wireless remote control)	
H4P	Light emitting diode (service monitor green)	A3P	Printed circuit board
H5P	Light emitting diode (service monitor green)	BS1	Push button (on/off)
MIS	Motor (Swing flap)	H1P	Light emitting diode (On-red)
MIF	Motor (Indoor flap)	H2P	Light Emitting diode (Timer-green)
MTP	Motor (Drain pump)	H3P	Light Emitting diode (Filter sign-red)
O1M	Thermo switch (MIF embedded)	H4P	Light emitting diode (Defrost-Orange)
R1T	Thermistor (Air)	SS1	Selector switch (Main/sub)
R2A	Magnetic relay (MTA)	SS2	Selector switch (Wireless address set)
R3P	Magnetic relay (MTP)	Connector for optional parts	
S10	Limit switch (Swing flap)	X24A	Connector (Wireless remote control)
SS1	Float switch	X30A	Connector (Interface adapter for sky air series)
V1TR	Phase control circuit (Emergency)	X35A	Connector (Group control adapter)
X1M	Terminal strip		
X2M	Terminal strip		
CEC	Signal receiver		
CTC	Signal transmission circuit		

- (Notes)
- □ □ □ □ : Terminal
 - ⊞ : Field wiring
 - The bev unit shows an outline, please refer to a wiring diagram of bev unit pasting in detail.
 - In case using central remote control, connect it to the unit in accordance with the attached installation manual.
 - X24A is connected when the wireless remote control kit is being used.
 - Remote control model varies according to the combination system, confirm engineering materials and catalogs, etc. Before connecting.
 - Confirm the method of setting the selector switch (SS1, SS2) of wired remote control and infrared remote control by installation manual and engineering data, etc.
 - Symbols shows as follows:
RED: Red - BLK: Black - WHT: White - YLW: Yellow - GRN: Green - BLU: Blue

BEVQ71MA / 100MA / 125MAVE

Bev unit	
A1P	Printed circuit board assy
A2P	Power supply printed circuit board assy (220-240V/16V)
F1U	Fuse (Ⓑ), 10A, 250V
HAP	Light emitting diode (Service monitor-green)
R3T	Thermistor (Gas)
SS1	Selector switch (M/S)
X1M	Terminal strip (power)
X2M	Terminal strip (Transmission)
Y1E	Electronic expansion valve
Z1C-Z2C Z3C-Z4F	Noise filter

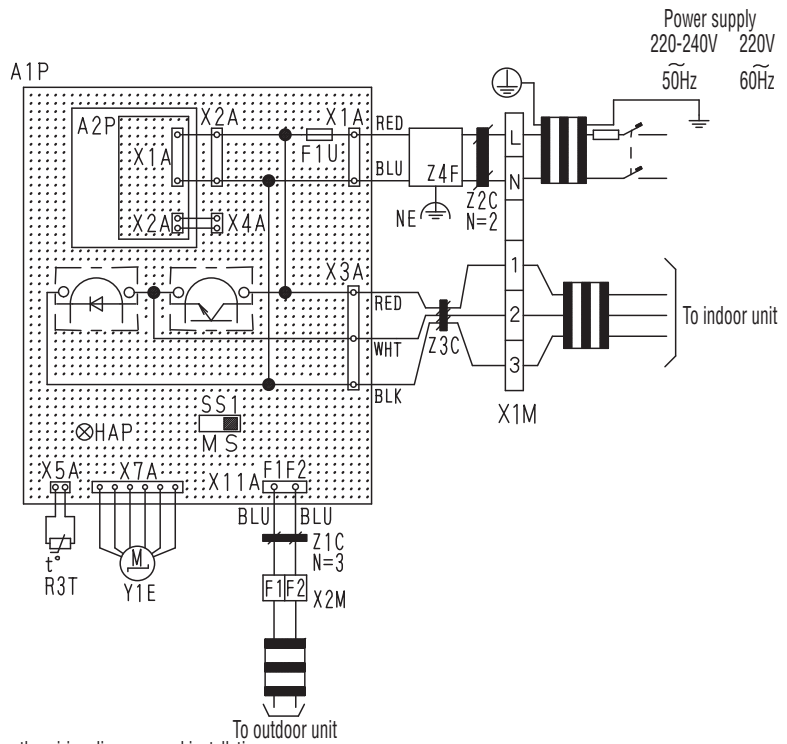
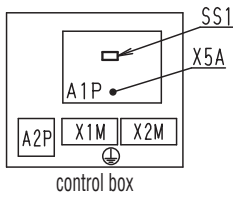

Note: 1. □□□□: Terminal □○□: Connector
 2. ≡≡≡: Field wiring

- This wiring diagram only shows the bev unit. see the wiring diagrams and installation manuals for the wiring and settings for the indoor, outdoor and BS units.
- See the indoor unit's wiring diagram when installing optional parts for the indoor unit.
- Only one indoor unit may be connected to the bev unit
- See the indoor unit's wiring diagram for when connecting the remote control.
- Always use the sky air connection adapter for the unit when using a central control unit. refer to the manual attached the unit when connecting.
- Cool/heat changeover of indoor units connected to bev unit cannot be carried out unless they are connected to BS unit. In case of a system with bev unit only, cool/heat selector is required.
- Set the SS1 to "M" only for the bev unit connected to the indoor unit which is to have cool/heat switching capability, when connecting the BS unit. the "M/S" on the SS1 stands for "Main/sub". this is set to "S" when shipped from the factory.
- Connected the attached thermistor to the R3T.
- Symbols shows as follows.
(BLU: Blue - RED: Red - WHT: White - BLK: Black)

3D044901B

2.4 BS Unit

A1P	PRINTED CIRCUIT BOARD	Y2E	ELECTRIC EXPANSION VALVE (SUB DISCHARGE)
DS1, DS2	DIP SWITCH	Y3E	ELECTRIC EXPANSION VALVE (SUB SUCTION)
F1U	FUSE (T, 3.15A, 250V)	Y4E	ELECTRIC EXPANSION VALVE (MAIN DISCHARGE)
HAP	FLASHING LAMP (SERVICE MONITOR-GREEN)	Y5E	ELECTRIC EXPANSION VALVE (MAIN SUCTION)
PS	SWITCHING POWER SUPPLY (A1P)	Z1C	NOISE FILTER (FERRITE CORE)
X1M	TERMINAL STRIP (POWER)	X2A	CONNECTOR FOR OPTIONAL PARTS
X1M (A1P)	TERMINAL STRIP (CONTROL)	X2M	ADAPTOR FOR OUTDOOR UNIT
X2M	TERMINAL STRIP (C/H SELECTOR)	Y1E	ELECTRIC EXPANSION VALVE (SUB COOL)

- NOTES) 1. THIS WIRING DIAGRAM APPLIES TO THE BS UNIT ONLY.
2. : TERMINAL STRIP, : TERMINAL
3. : FIELD WIRING, : PROTECTIVE EARTH
4. WHEN USING THE COOL/HEAT SELECTOR (OPTIONAL ACCESSORY), CONNECT IT TO TERMINALS A, B AND C ON X2M.
5. AS FOR WIRING TO THE IN/D UNIT (F1) · (F2) AND OUT/D UNIT (F1) · (F2) ON X1M (A1P), REFER TO INSTALLATION MANUAL.
6. USE COPPER CONDUCTORS ONLY.
7. DIP SWITCH (DS1 · 2) INITIAL SETTINGS ARE AS FOLLOWS.
- 1 2 3 4 1 2 3 4 1 2 3 4
 ON OFF DS1 DS2
 ON OFF DS1 DS2
- BSVQ100PV1 BSVQ160PV1 BSVQ250PV1
- FOR USING DIP SWITCH (DS1 · 2), REFER TO INSTALLATION MANUAL OR "SERVICE PRECAUTION" LABEL ON EL. COMPO. BOX COVER.

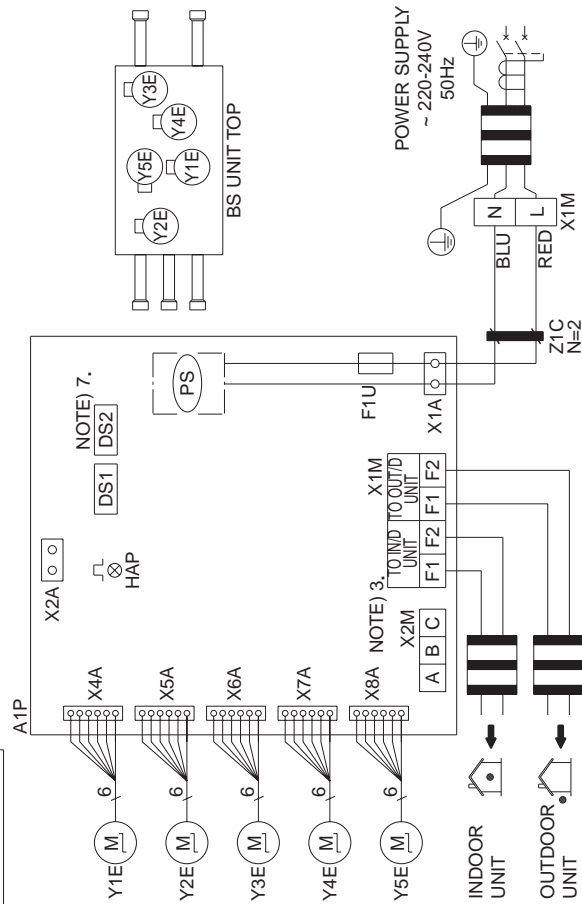

3. List of Electrical and Functional Parts

3.1 Outdoor Unit

3.1.1 REYQ8P8Y1B~12P8Y1B

Item	Name		Symbol	Model		
				REYQ8P8Y1B	REYQ10P8Y1B	REYQ12P8Y1B
Compressor	Inverter	Type	M1C	JT1GCVDKYR@SA		
		OC protection device		14.7A		
	STD 1	Type	M2C	JT170G-KYE@T		
		OC protection device		15.0A		
	STD 2	Type	M3C	—		
		OC protection device		—		
Fan motor		OC protection device	M1F	3.0A		3.0A (for General overseas : 1.14A)
Electronic expansion valve (Main)			Y1E	Fully closed: 0pls Fully open: 1375pls		
Electronic expansion valve (Subcool)			Y2E	Fully closed: 0pls Fully open: 480pls		
Electronic expansion valve (Refrigerant charge)			EV	0~480pls		
Pressure protection	High pressure switch	For M1C	S1PH	OFF: $4.0^{+0}_{-0.12}$ MPa ON: 3.0 ± 0.15 MPa		
		For M2C	S2PH	OFF: $4.0^{+0}_{-0.12}$ MPa ON: 3.0 ± 0.15 MPa		
		For M3C	S3PH	—		
	Low pressure sensor		SENPL	OFF: 0.07MPa		
Temperature protection	Discharge gas temperature protection (Discharge pipe thermistor)		R3T	OFF: 135°C		
	Inverter fin temperature protection (Radiator fin thermistor)		R1T	OFF: 93°C		
Others	Fuse	For main PC board	F1U	250V AC 10A Class B Time-lag 3.15A AC 250V		
			F2U	250V AC 10A Class B Time-lag 3.15A AC 250V		
		For Noise filter PC board	F1U	250V AC 5A Class B		

3.1.2 REYQ14P8Y1B~16P8Y1B

Item	Name		Symbol	Model	
				REYQ14P8Y1B	REYQ16P8Y1B
Compressor	Inverter	Type	M1C	JT1GCVDKYR@SA	
		OC protection device		14.7A	
	STD 1	Type	M2C	JT170G-KYE@T	
		OC protection device		15.0A	
	STD 2	Type	M3C	JT170G-KYE@T	
		OC protection device		15.0A	
Fan motor		OC protection device	M1F, M2F	1.2A	
Electronic expansion valve (Main)			Y1E	Fully closed: 0pls Fully open: 1375pls	
Electronic expansion valve (Subcool)			Y2E	Fully closed: 0pls Fully open: 480pls	
Electronic expansion valve (Refrigerant charge)			EV	0~480pls	
Pressure protection	High pressure switch	For M1C	S1PH	OFF: $4.0^{+0}_{-0.12}$ MPa ON: 3.0 ± 0.15 MPa	
		For M2C	S2PH	OFF: $4.0^{+0}_{-0.12}$ MPa ON: 3.0 ± 0.15 MPa	
		For M3C	S3PH	OFF: $4.0^{+0}_{-0.12}$ MPa ON: 3.0 ± 0.15 MPa	
	Low pressure sensor		SENPL	OFF: 0.07MPa	
Temperature protection	Discharge gas temperature protection (Discharge pipe thermistor)		R3T	OFF: 135°C	
	Inverter fin temperature protection (Radiator fin thermistor)		R1T	OFF: 93°C	
Others	Fuse	For main PC board	F1U	250V AC 10A Class B Time-lag 3.15A AC 250V	
			F2U	250V AC 10A Class B Time-lag 3.15A AC 250V	
		For Noise filter PC board	F1U	250V AC 5A Class B	

3.1.3 REMQ8P8Y1B~12P8Y1B

Item	Name		Symbol	Model		
				REMQ8P8Y1B	REMQ10P8Y1B	REMQ12P8Y1B
Compressor	Inverter	Type	M1C	JT1GCVDKYR@SA		
		OC protection device		14.7A		
	STD 1	Type	M2C	—	JT170G-KYE@T	
		OC protection device		—	15.0A	
	STD 2	Type	M3C	—	—	
		OC protection device		—	—	
Fan motor		OC protection device	M1F	3.0A		
Electronic expansion valve (Main)			Y1E	Fully closed : 0pls	Fully open : 480pls	
Electronic expansion valve (Refrigerant charge)			Y2E	Fully closed : 0pls	Fully open : 480pls	
Electronic expansion valve (Subcool)			Y3E	Fully closed : 0pls	Fully open : 480pls	
Pressure protection	High pressure switch	For M1C	S1PH	OFF : 4.0 ⁺⁰ _{-0.12} MPa	ON : 3.0±0.15MPa	
		For M2C	S2PH	OFF : 4.0 ⁺⁰ _{-0.12} MPa	ON : 3.0±0.15MPa	
		For M3C	S3PH	—		
	Low pressure sensor		SENPL	OFF : 0.07MPa		
Temperature protection	Discharge gas temperature protection (Discharge pipe thermistor)		R3T	OFF : 135°C		
	Inverter fin temperature protection (Radiator fin thermistor)		R1T	OFF : 93°C		
Others	Fuse	For main PC board	F1U	Time-lag 3.15A AC 250V / 250V AC 10A Class B		
			F2U	Time-lag 3.15A AC 250V / 250V AC 10A Class B		
		For Noise filter PC board	F1U	250V AC 5A Class B		

3.1.4 REMQ14P8Y1B~16P8Y1B

Item	Name		Symbol	Model	
				REMQ14P8Y1B	REMQ16P8Y1B
Compressor	Inverter	Type	M1C	JT1GCVDKYR@SA	
		OC protection device		14.7A	
	STD 1	Type	M2C	JT170G-KYE@T	
		OC protection device		15.0A	
	STD 2	Type	M3C	JT170G-KYE@T	
		OC protection device		15.0A	
Fan motor	OC protection device		M1F, M2F	1.2A	
Electronic expansion valve (Main)			Y1E	Fully closed : 0pls	Fully open : 480pls
Electronic expansion valve (Refrigerant charge)			Y2E	Fully closed : 0pls	Fully open : 480pls
Electronic expansion valve (Subcool)			Y3E	Fully closed : 0pls	Fully open : 480pls
Pressure protection	High pressure switch	For M1C	S1PH	OFF : 4.0 ⁺⁰ _{-0.12} MPa	ON : 3.0±0.15MPa
		For M2C	S2PH	OFF : 4.0 ⁺⁰ _{-0.12} MPa	ON : 3.0±0.15MPa
		For M3C	S3PH	OFF : 4.0 ⁺⁰ _{-0.12} MPa	ON : 3.0±0.15MPa
	Low pressure sensor		SENPL	OFF : 0.07MPa	
Temperature protection	Discharge gas temperature protection (Discharge pipe thermistor)		R3T	OFF : 135°C	
	Inverter fin temperature protection (Radiator fin thermistor)		R1T	OFF : 93°C	
Others	Fuse	For main PC board	F1U	Time-lag 3.15A AC 250V / 250V AC 10A Class B	
			F2U	Time-lag 3.15A AC 250V / 250V AC 10A Class B	
		For Noise filter PC board	F1U	250V AC 5A Class B	

3.2 Indoor Side

3.2.1 Indoor Unit

Parts Name		Symbol	Model								Remark
			FXFQ20 PVE	FXFQ25 PVE	FXFQ32 PVE	FXFQ40 PVE	FXFQ50 PVE	FXFQ63 PVE	FXFQ80 PVE	FXFQ 100 PVE	
Remote Controller	Wired Remote Control		BRC1D52								Option
	Infrared Remote Control		BRC7F532								
Motors	Fan Motor	M1F	Thermal Protector : OFF : 108 ^{±5} (ON : 96 ^{±15})								
	Drain Pump	M1P	AC220-240V (50Hz) AC220V (60Hz) PLD-12230DM Thermal Fuse 145°C								
	Swing Motor	M1S	MP35HCA[3P007482-1] Stepping Motor DC16V								
Thermistors	Thermistor (Suction Air)	R1T	In PC board A4P or wired remote control								
	Thermistor (for Heat Exchanger High Temp.)	R3T	ST8605-5 φ8 L1000 20kΩ (25°C)								
	Thermistor (Heat Exchanger)	R2T	ST8602A-5 φ6 L1000 20kΩ (25°C)								
Others	Float Switch	S1L	FS-0211B								
	Fuse	F1U	250V 5A φ5.2								
	Thermal Fuse	TFu	—								
	Transformer	T1R	—								

Parts Name		Symbol	Model								Remark
			FXCQ 20MV3	FXCQ 25MV3	FXCQ 32MV3	FXCQ 40MV3	FXCQ 50MV3	FXCQ 63MV3	FXCQ 80MV3	FXCQ 125 MV3	
Remote Controller	Wired Remote Control		BRC1D52								Option
	Infrared Remote Control		BRC7C62								
Motors	Fan Motor	M1F	AC 220~240V 50Hz								
			1φ10W	1φ15W	1φ20W	1φ30W	1φ50W	1φ85W			
				Thermal Fuse 152°C		—	Thermal protector 135°C : OFF 87°C : ON				
	Drain Pump	M1P	AC220-240V (50Hz) AC220V (60Hz) PLD-12230DM Thermal Fuse 145°C								
	Swing Motor	M1S	MT8-L[3PA07509-1] AC200~240V								
Thermistors	Thermistor (Suction Air)	R1T	ST8601-6 φ4 L1250 20kΩ (25°C)								
	Thermistor (for Heat Exchanger High Temp.)	R3T	ST8605-6 φ8 L1250 20kΩ (25°C)								
	Thermistor (Heat Exchanger)	R2T	ST8602A-5 φ6 L1000 20kΩ (25°C)								
Others	Float Switch	S1L	FS-0211B								
	Fuse	F1U	250V 5A φ5.2								
	Transformer	T1R	TR22H21R8								

Parts Name		Symbol	Model					Remark
			FXZQ 20MV1	FXZQ 25MV1	FXZQ 32MV1	FXZQ 40MV1	FXZQ 50MV1	
Remote Controller	Wired Remote Control		BRC1D52					Option
	Infrared Remote Control		BRC7E530					
Motors	Fan Motor	M1F	AC 220~240V 50Hz					
			1φ55W 4P					
			Thermal Fuse OFF : 130 ^{±5} / ON : 80 ^{±20}					
	Capacitor, fan motor	C1	4.0μ F 400VAC					
	Drain Pump	M1P	AC220-240V (50Hz) PLD-12230DM Thermal Fuse 145°C					
Swing Motor	M1S	MP35HCA [3P080801-1] AC200~240V						
Thermistors	Thermistor (Suction Air)	R1T	ST8601A-1 φ4 L250 20kΩ (25°C)					
	Thermistor (for Heat Exchanger High Temp.)	R3T	ST8605-3 φ8 L630 20kΩ (25°C)					
	Thermistor (Heat Exchanger)	R2T	ST8602A-3 φ6 L630 20kΩ (25°C)					
Others	Float Switch	S1L	FS-0211					
	Fuse	F1U	250V 5A φ5.2					
	Transformer	T1R	TR22H21R8					

Parts Name		Symbol	Model				Remark	
			FXKQ 25MAVE	FXKQ 32MAVE	FXKQ 40MAVE	FXKQ 63MAVE		
Remote Controller	Wired Remote Control		BRC1D52				Option	
	Infrared Remote Control		BRC4C61					
Motors	Fan Motor	M1F	AC 220~240V 50Hz					
			1φ15W 4P		1φ20W 4P	1φ45W 4P		
			Thermal Fuse 146°C		Thermal protector 120°C : OFF 105°C : ON			
	Drain Pump	M1P	AC 220-240V (50Hz) PLD-12200DM Thermal Fuse 145°C					
Swing Motor	M1S	MP35HCA [3P080801-1] AC200~240V						
Thermistors	Thermistor (Suction Air)	R1T	ST8601-13 φ4 L630 20kΩ (25°C)					
	Thermistor (for Heat Exchanger High Temp.)	R3T	ST8605-7 φ8 L1600 20kΩ (25°C)					
	Thermistor (Heat Exchanger)	R2T	ST8602A-7 φ6 L1600 20kΩ (25°C)					
Others	Float Switch	S1L	FS-0211B					
	Fuse	F1U	250V 5A φ5.2					
	Transformer	T1R	TR22H21R8					

Parts Name		Symbol	Model					Remark
			FXDQ 20NAVE, PVE	FXDQ 25NAVE, PVE	FXDQ 32NAVE, PVE	FXDQ 40NAVE	FXDQ 50NAVE	
Remote Controller	Wired Remote Control		BRC1D52					Option
	Infrared Remote Control		BRC4C62					
Motors	Fan Motor	M1F	AC 220~240V 50Hz					
			1φ62W		1φ130W			
			Thermal protector 130°C: OFF, 83°C: ON					
	Drain Pump	M1P	AC220-240V (50Hz) PLD-12230DM Thermal Fuse 145°C					*
Thermistors	Thermistor (Suction Air)	R1T	ST8601-1 φ4 L=250 20kΩ (25°C)					
	Thermistor (for Heat Exchanger High Temp.)	R3T	ST8605-4 φ8 L=800 20kΩ (25°C)					
	Thermistor (Heat Exchanger)	R2T	ST8602A-4 φ6 L=800 20kΩ (25°C)					
Others	Float Switch	S1L	FS-0211E					*
	Fuse	F1U	250V 5A φ5.2					
	Transformer	T1R	TR22H21R8					

*only for FXDQ20~63N(A)VE, FXDQ20~32PVE (with Drain Pump Type)

Parts Name		Symbol	Model		Remark
			FXDQ20MV3	FXDQ25MV3	
Remote Controller	Wired Remote Control		BRC1D52		Option
	Infrared Remote Control		BRC4C62		
Motors	Fan Motor	M1F			
			Thermal protector 135°C : OFF, 87°C : ON		
	Drain Pump	M1P			
Thermistors	Thermistor (Suction Air)	R1T			
	Thermistor (for Heat Exchanger High Temp.)	R3T			
	Thermistor (Heat Exchanger)	R2T			
Others	Float Switch	S1L			
	Fuse	F1U	250V 10A		
	Transformer	T1R			

Parts Name		Symbol	Model									Remark
			FXSQ 20 MV3	FXSQ 25 MV3	FXSQ 32 MV3	FXSQ 40 MV3	FXSQ 50 MV3	FXSQ 63 MV3	FXSQ 80 MV3	FXSQ 100 MV3	FXSQ 125 MV3	
Remote Controller	Wired Remote Control		BRC1D52									Option
	Infrared Remote Control		BRC4C62									
Motors	Fan Motor	M1F	AC 220~240V 50Hz									
			1φ50W			1φ65W	1φ85W	1φ125W	1φ225W			
	Thermal Fuse 152°C						Thermal protector 135°C : OFF 87°C : ON					
Thermistors	Drain Pump	M1P	AC220-240V (50Hz) PLD-12230DM Thermal Fuse 145°C									
	Thermistor (Suction Air)	R1T	ST8601-4 φ4 L800 20kΩ (25°C)									
	Thermistor (for Heat Exchanger High Temp.)	R3T	ST8605-7 φ8 L1600 20kΩ (25°C)									
Others	Thermistor (Heat Exchanger)	R2T	ST8602A-6 φ6 L1250 20kΩ (25°C)									
	Float Switch	S1L	FS-0211B									
	Fuse	F1U	250V 5A φ5.2									
	Transformer	T1R	TR22H21R8									

Parts Name		Symbol	Model							Remark
			FXMQ 40MAVE	FXMQ 50MAVE	FXMQ 63MAVE	FXMQ 80MAVE	FXMQ 100MAVE	FXMQ 125MAVE	FXMQ 200MAVE	
Remote Controller	Wired Remote Control		BRC1D52							Option
	Infrared Remote Control		BRC4C62							
Motors	Fan Motor	M1F	AC 220~240V 50Hz							
			1φ100W		1φ160W	1φ270W	1φ430W	1φ380W×2		
	Thermal protector 135°C : OFF				87°C : ON					
	Capacitor for Fan Motor	C1R	5μ F-400V		7μ F 400V	10μ F 400V	8μ F 400V	10μ F 400V	12μ F 400V	
Thermistors	Thermistor (Suction Air)	R1T	ST8601A-5 φ4 L1000 20kΩ (25°C)				ST8601A-13 φ4 L630			
	Thermistor (for Heat Exchanger High Temp.)	R3T	ST8605A-4 φ8 L800 20kΩ (25°C)				ST8605A-5 φ8 L1000			
	Thermistor (Heat Exchanger)	R2T	ST8602A-4 φ6 L800 20kΩ (25°C)				ST8602A-6 φ6 L1250			
Others	Float switch	S1L	FS-0211							
	Fuse	F1U	250V 5A φ5.2			250V 10A φ5.2		250V 5A φ5.2		
	Transformer	T1R	TR22H21R8							

Parts Name		Symbol	Model			Remark
			FXHQ 32MAVE	FXHQ 63MAVE	FXHQ 100MAVE	
Remote Controller	Wired Remote Control		BRC1D52			Option
	Wireless Controller		BRC7E63W			
Motors	Fan Motor	M1F	AC 220~240V/220V 50Hz/60Hz			
			1φ63W		1φ130W	
			Thermal protector 130°C : OFF 80°C : ON			
	Capacitor for Fan Motor	C1R	3.0μF-400V		9.0μF-400V	
Swing Motor	M1S	MT8-L[3P058751-1] AC200~240V				
Thermistors	Thermistor (Suction Air)	R1T	ST8601A-1 φ4 L250 20kΩ (25°C)			
	Thermistor (for Heat Exchanger High Temp.)	R3T	ST8605-6 φ8 L = 1250 20kΩ (25°C)		ST8605-6 φ8 L = 1250 20kΩ (25°C)	
	Thermistor (Heat Exchanger)	R2T	ST8602A-6 φ6 L = 1250 20kΩ (25°C)		ST8602A-6 φ6 L = 1250 20kΩ (25°C)	
Others	Fuse	F1U	250V 5A φ5.2			
	Transformer	T1R	TR22H21R8			

Parts Name		Symbol	Model						Remark
			FXAQ 20MAVE	FXAQ 25MAVE	FXAQ 32MAVE	FXAQ 40MAVE	FXAQ 50MAVE	FXAQ 63MAVE	
Remote Controller	Wired Remote Control		BRC1D52						Option
	Infrared Remote Control		BRC7E618						
Motors	Fan Motor	M1F	AC 220~240V 50Hz						
			1φ40W			1φ43W			
			Thermal protector 130°C : OFF 80°C : ON						
Swing Motor	M1S	MP24 [3SB40333-1] AC200~240V			MSFBC20C21 [3SB40550-1] AC200~240V				
Thermistors	Thermistor (Suction Air)	R1T	ST8601-2 φ4 L400 20kΩ (25°C)						
	Thermistor (for Heat Exchanger High Temp.)	R3T	ST8605-2 φ8 L400 20kΩ (25°C)						
	Thermistor (for Heat Exchanger)	R2T	ST8602-2 φ6 L400 20kΩ (25°C)						
Others	Float Switch	S1L	OPTION						
	Fuse	F1U	250V 5A φ5.2						

Parts Name		Symbol	Model						Remark
			FXLQ 20MAVE	FXLQ 25MAVE	FXLQ 32MAVE	FXLQ 40MAVE	FXLQ 50MAVE	FXLQ 63MAVE	
Remote Controller	Wired Remote Control		BRC1D52						Option
	Infrared Remote Control		BRC4C62						
Motors	Fan Motor	M1F	AC 220~240V 50Hz						
			1 ϕ 15W	1 ϕ 25W		1 ϕ 35W			
	Capacitor for Fan Motor	C1R	1.0 μ F-400V	0.5 μ F-400V	1.0 μ F-400V	1.5 μ F-400V	2.0 μ F-400V		
Thermistors	Thermistor (Suction Air)	R1T	ST8601-6 ϕ 4 L1250 20k Ω (25°C)						
	Thermistor (for Heat Exchanger High Temp.)	R3T	ST8605-9 ϕ 8 L2500 20k Ω (25°C)						
	Thermistor (for Heat Exchanger)	R2T	ST8602A-9 ϕ 6 L2500 20k Ω (25°C)						
Others	Fuse	F1U	AC250V 5A						
	Transformer	T1R	TR22H21R8						

Parts Name		Symbol	Model						Remark
			FXNQ 20MAVE	FXNQ 25MAVE	FXNQ 32MAVE	FXNQ 40MAVE	FXNQ 50MAVE	FXNQ 63MAVE	
Remote Controller	Wired Remote Control		BRC1D52						Option
	Infrared Remote Control		BRC4C62						
Motors	Fan Motor	M1F	AC 220~240V 50Hz						
			1 ϕ 15W	1 ϕ 25W		1 ϕ 35W			
	Capacitor for Fan Motor	C1R	1.0 μ F-400V	0.5 μ F-400V	1.0 μ F-400V	1.5 μ F-400V	2.0 μ F-400V		
Thermistors	Thermistor (Suction Air)	R1T	ST8601-6 ϕ 4 L1250 20k Ω (25°C)						
	Thermistor (for Heat Exchanger High Temp.)	R3T	ST8605-9 ϕ 8 L2500 20k Ω (25°C)						
	Thermistor (for Heat Exchanger)	R2T	ST8602A-9 ϕ 6 L2500 20k Ω (25°C)						
Others	Fuse	F1U	AC250V 5A						
	Transformer	T1R	TR22H21R8						

Parts Name		Symbol	Model			Remark
			FXUQ71MAV1	FXUQ100MAV1	FXUQ125MAV1	
Remote Controller	Wired Remote Control		BRC1C62			Option
	Infrared Remote Control		BRC7C528W			
Motors	Fan Motor	M1F	AC 220~240V 50Hz			
			1 ϕ 45W	1 ϕ 90W		
	Drain Pump	M1P	AC220-240V (50Hz) AC220V (60Hz) PJV-1426			
	Swing Motor	M1S	MT8-L[3PA07572-1] AC200~240V			
Thermistors	Thermistor (Suction Air)	R1T	ST8601-1 ϕ 4 L=250 20k Ω (25°C)			
	Thermistor (Heat Exchanger)	R2T	ST8602A-4 ϕ 6 L=800 20k Ω (25°C)			
Others	Float Switch	S1L	FS-0211B			

4. Option List

4.1 Option List of Controllers

Operation Control System Optional Accessories

No.	Item	Type		FXCQ-M8	FXFQ-P	FXZQ-M	FXKQ-MA	FXDQ-P FXDQ-NA	FXSQ-M	FXDQ-M	FXMQ-MA	FXHQ-MA	FXAQ-MA	FXLQ-MA FXNQ-MA	FXUQ-MA
		Infrared	H/R												
1	Remote Control	Infrared	H/R	BRC7C62	BRC7F532F	BRC7E530	BRC4C61	BRC4C62	BRC4C62	BRC4C62	BRC4C62	BRC7E63	BRC7E618	BRC4C62	BRC7C528W
		Wired		BRC1D52											
2	Wired remote control with weekly schedule timer				BRC1D528	BRC1D61									
3	Simplified remote control (Exposed type)			—				BRC2C51				—		BRC2C51	—
4	Remote Control for hotel use (Concealed type)			—				BRC3A61				—		BRC3A61	—
5	Adapter for wiring			★KRP1B61	—	★KRP1B57	KRP1B61	★KRP1B56	—	KRP1B61		KRP1B3	—	KRP1B61	—
6-1	Wiring adapter for electrical appendices (1)			★KRP2A61	★KRP2A526	★KRP2A526	KRP2A61	★KRP2A53	KRP2A516	KRP2A51		★KRP2A62	★KRP2A51	KRP2A51	KRP2A62
6-2	Wiring adapter for electrical appendices (2)			★KRP4A51	★KRP4AA53	★KRP4A536	KRP4A51	★KRP4A54	KRP4A516	KRP4A51		★KRP4A52	★KRP4A51	KRP4A51	KRP4A53
7	Remote sensor			KRCS01-1	KRCS01-4	KRCS01-1	KRCS01-1								
8	Installation box for adapter PC board ☆			Note 2,3 KRP1B96	Note 2,3 KRP1H98	Note 4,6 KRP1BA101	—	Note 4,6 KRP1BA101	Note 5 KRP4A91	—		Note 3 KRP1C93	Note 2,3 KRP4A93	—	KRP1B97
9	External control adapter for outdoor unit (Must be installed on indoor units)			★DTA104A61	★DTA104A52	DTA104A61	★DTA104A53	DTA104A51	DTA104A61		★DTA104A62	★DTA104A51	DTA104A61	DTA102A52	

Note:

1. Installation box ☆ is necessary for each adapter marked * .
2. Up to 2 adapters can be fixed for each installation box.
3. Only one installation box can be installed for each indoor unit.
4. Up to 2 installation boxes can be installed for each indoor unit.
5. Installation box ☆ is necessary for second adapter.
6. Installation box ☆ is necessary for each adapter.

Various PC Boards

No.	Part name	Model No.	Function
1	Adapter for wiring	KRP1B56 KRP1B57 KRP1B61 KRP1B3	■ PC board when equipped with auxiliary electric heater in the indoor unit.
2	DIII-NET Expander Adapter	DTA109A51	■ Up to 1,024 units can be centrally controlled in 64 different groups. ■ Wiring restrictions (max. length: 1,000 m, total wiring length: 2,000 m, max. number of branches: 16) apply to each adapter.

System Configuration

No.	Part name	Model No.	Function
1	Central remote control	DCS302C51 DCS302CA51 (FXFQ-P)	• Up to 64 groups of indoor units(128 units) can be connected, and ON/OFF, temperature setting and monitoring can be accomplished individually or simultaneously. Connectable up to 2 controllers in one system.
1-1	Electrical box with earth terminal (3 blocks)	KJB311A	
2	Unified ON/OFF controller	DCS301B51 DCS301BA51 (FXFQ-P)	• Up to 16 groups of indoor units(128 units) can be turned, ON/OFF individually or simultaneously, and operation and malfunction can be displayed. Can be used in combination with up to 8 controllers.
2-1	Electrical box with earth terminal (2 blocks)	KJB212A	
2-2	Noise filter (for electromagnetic interface use only)	KEK26-1	
3	Schedule timer	DST301B51 DST301BA51 (FXFQ-P)	• Programmed time weekly schedule can be controlled by unified control for up to 64 groups of indoor units (128 units). Can turn units ON/OFF twice per day.
4	Interface adapter for SkyAir-series	R-407C/R-22	★DTA102A52
		R-410A	
5	Central control adapter kit	For UAT(Y)-K(A),FD-K	★DTA107A55
6	Wiring adapter for other air-conditioner		★DTA103A51
7	DIII -NET Expander Adapter		DTA109A51
7-1	Mounting plate		KRP4A92

Note:

1. Installation box for * adapter must be procured on site.

Building Management System

No.	Part name				Model No.	Function	
1	intelligent Touch Controller	Basic	Hardware	intelligent Touch Controller	DCS601C51	• Air-Conditioning management system that can be controlled by a compact all-in-one unit.	
1-1		Option	Hardware	DIII-NET plus adapter	DCS601A52	• Additional 64 groups (10 outdoor units) is possible.	
1-2			Software	P. P. D.	DCS002C51	• P. P. D.: Power Proportional Distribution function	
1-3			Web	DCS004A51	• Monitors and controls the air conditioning system using the Internet and a Web browser application on a PC.		
1-4	Electrical box with earth terminal (4 blocks)				KJB411A	• Wall embedded switch box.	
2	intelligent Manager III	Basic	Hardware	Number of units to be connected	128 units	DAM602B52	• Air conditioner management system that can be controlled by personal computers.
					256 units	DAM602B51	
					512 units	DAM602B51x2	
					768 units	DAM602B51x3	
					1024 units	DAM602B51x4	
2-1	Option	Software	P.P.D.	DAM002A51	• Power Proportional Distribution function		
2-2			Web	DAM004A51	• Monitors and controls the air conditioning system using the Internet and a Web browser application on a PC.		
2-3			Eco	DAM003A51	• ECO (Energy saving functions.)		
2-4	Optional DIII Ai unit				DAM101A51	• External temperature sensor for intelligent Manager III.	
2-5	Di unit				DEC101B51	• Input contacts: 16 points	
2-6	Dio unit				DEC102B51	• Input contacts: 8 points; output contacts: 4 points	
3	Communication line	*1 Interface for use in BACnet®			DMS502B51	• Interface unit to allow communications between VRV and BMS. Operation and monitoring of air-conditioning systems through BACnet® communication.	
3-1		Optional DIII board			DAM411B51	• Expansion kit, installed on DMS502B51, to provide 2 more DIII-NET communication ports. Not usable independently.	
3-2		Optional Di board			DAM412B51	• Expansion kit, installed on DMS502B51, to provide 16 more wattmeter pulse input points. Not usable independently.	
4		*2 Interface for use in LONWORKS®			DMS504B51	• Interface unit to allow communications between VRV and BMS. Operation and monitoring of air-conditioning systems through LONWORKS® communication.	
5	Contact/analog signal	Parallel interface Basic unit			DPF201A51	• Enables ON/OFF command, operation and display of malfunction; can be used in combination with up to 4 units.	
6		Temperature measurement units			DPF201A52	• Enables temperature measurement output for 4 groups; 0-5VDC.	
7		Temperature setting units			DPF201A53	• Enables temperature setting input for 16 groups; 0-5VDC.	
8		Unification adapter for computerized control			★DCS302A52	• Interface between the central monitoring board and central control units.	

Notes:

- *1. BACnet® is a registered trademark of American Society of Heating, Refrigerating and Air-Conditioning Engineers (ASHRAE).
- *2. LONWORKS®, is a registered trade mark of Echelon Corporation.
- *3. Installation box for * adapter must be procured on site.

4.2 Option Lists (Outdoor Unit)

REYQ8 ~ 16PY1

Series		VRV III H/R	
Models		REYQ8PY1	REYQ10PY1 REYQ12PY1 REYQ14PY1 REYQ16PY1
Optional accessories			
Distributive Piping	Refnet header	Model	KHRP25M33H (Max. 8 branch)
	Refnet joint	Model	KHRP25A22T, KHRP25A33T
Central drain pan kit		Model	KWC25C450
Digital pressure gauge kit		Model	BHGP26A1

C : 3D057610A

REYQ18 ~ 32PY1

Series		VRV III H/R	
Models		REYQ18PY1	REYQ20PY1 REYQ22PY1 REYQ24PY1
Optional accessories			
Distributive Piping	Refnet header	Model	KHRP25M33H, KHRP25M72H (Max. 8 branch) (Max. 8 branch)
	Refnet joint	Model	KHRP25A22T, KHRP25A33T (KHRP25A72T+KHRP25M72TP)
Outdoor unit multi connection piping kit		Model	BHFP26P90
Central drain pan kit		Model	KWC26C280×2
Digital pressure gauge kit		Model	BHGP26A1

Series		VRV III H/R	
Models		REYQ26PY1 REYQ28PY1	REYQ30PY1 REYQ32PY1
Optional accessories			
Distributive Piping	Refnet header	Model	KHRP25M33H, KHRP25M72H, KHRP25M73H (Max. 8 branch) (Max. 8 branch) (Max. 8 branch)
	Refnet joint	Model	KHRP25A22T, KHRP25A33T, (KHRP25A72T+KHRP25M72TP), (KHRP25A73T+KHRP25M73TP)
Outdoor unit multi connection piping kit		Model	BHFP26P90
Central drain pan kit		Model	KWC26C280 KWC26C450
Digital pressure gauge kit		Model	BHGP26A1

C : 3D057611C

REYQ34 ~ 48PY1

Series		VRV III H/R	
Models		REYQ34PY1 REYQ36PY1 REYQ38PY1 REYQ40PY1	REYQ42PY1 REYQ44PY1
Optional accessories			
Distributive Piping	Refnet header	Model	KHRP25M33H, KHRP25M72H, KHRP25M73H (Max. 8 branch) (Max. 8 branch) (Max. 8 branch)
	Refnet joint	Model	KHRP25A22T, KHRP25A33T, (KHRP25A72T+KHRP25M72TP), (KHRP25A73T+KHRP25M73TP)
Outdoor unit multi connection piping kit		Model	BHFP26P136
Central drain pan kit		Model	KWC26C280×2 KWC26C450
Digital pressure gauge kit		Model	BHGP26A1

Series		VRV III H/R	
Models		REYQ46PY1 REYQ48PY1	
Optional accessories			
Distributive Piping	Refnet header	Model	KHRP25M33H, KHRP25M72H, KHRP25M73H (Max. 8 branch) (Max. 8 branch) (Max. 8 branch)
	Refnet joint	Model	KHRP25A22T, KHRP25A33T, (KHRP25A72T+KHRP25M72TP), (KHRP25A73T+KHRP25M73TP)
Outdoor unit multi connection piping kit		Model	BHFP26P136
Central drain pan kit		Model	KWC26C450×3
Digital pressure gauge kit		Model	BHGP26A1

C : 3D057612C

5. Piping Installation Point

5.1 Piping Installation Point

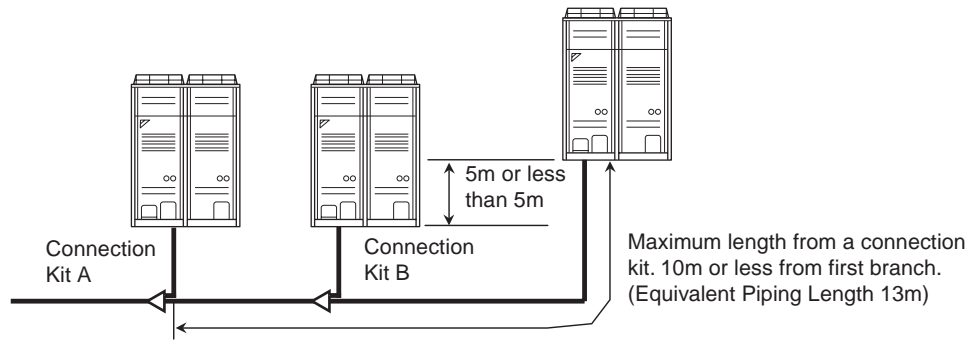

Since there is a possibility that oil may be collected on a stop machine side, install piping between outdoor units to go to level or go up to an outdoor unit, and to make a slope.

(V3036)

The projection part between multi connection piping kits

When the piping length between the multi connection kits or between multi connection kit and outdoor unit is 2m or more, prepare a vertical projection part (200mm or more as shown below) only on the gas pipe line location less than 2m from multi connection kit.

In the case of 2m or less

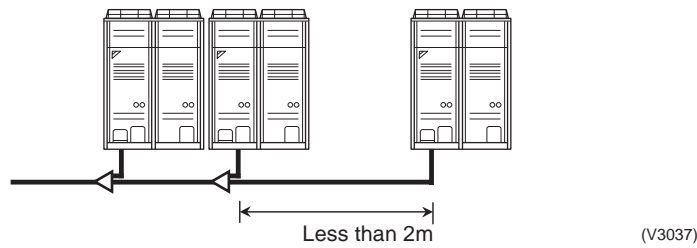

In the case of 2m or more

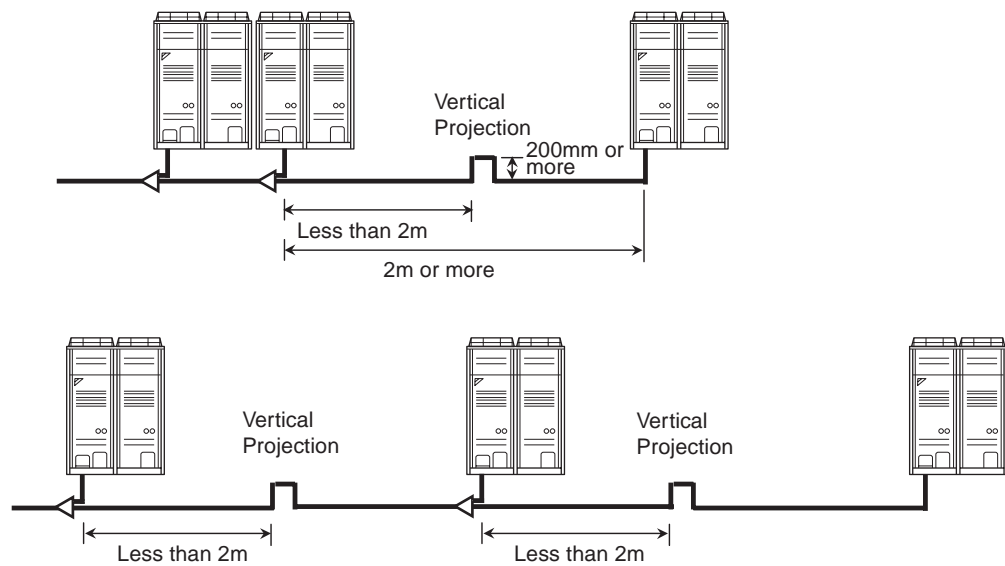

(V3038)

5.2 The Example of a Wrong Pattern

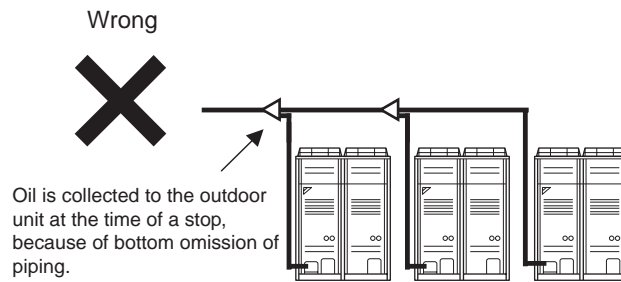

(V3039)

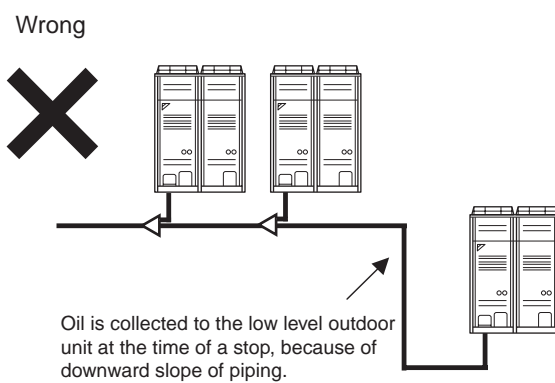

The example of installation on which oil is not collected.

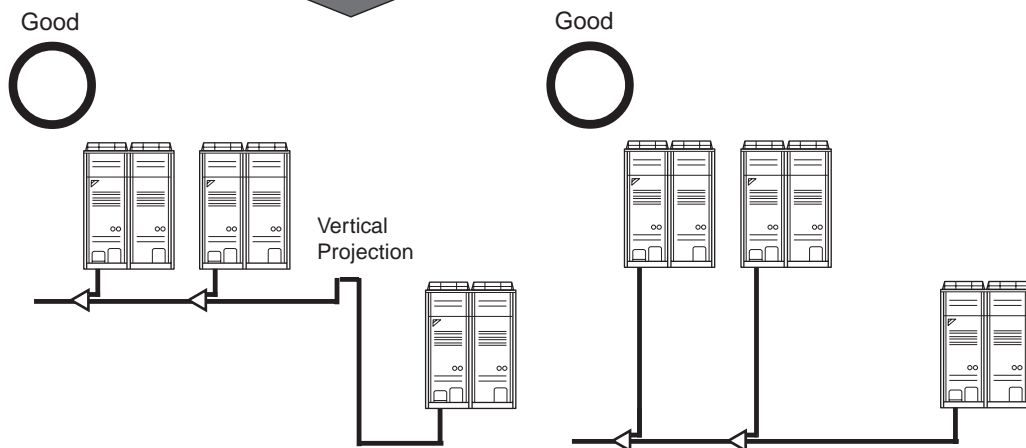

(V3040)

Max. allowable Piping Length	Outdoor Unit - Multi Connection Piping Kit	Actual piping length 10m or less, equivalent length 13m or less	
	Multi Connection Piping Kit - Indoor Unit	Actual piping length 165m or less, equivalent length 190m or less, the total extension 1000m or less	
	REFNET Joint - Indoor Unit	Actual piping length 40m or less (Refer to Page 467 Note 2 in case of up to 90m)	
Allowable Level Difference	Outdoor Unit - Outdoor Unit	5m or less	
	Outdoor Unit - Indoor Unit	Outdoor Unit is above	50m or less ★90m or less
		Outdoor Unit is below	90m
	Indoor Unit - Indoor Unit	15m or less	

Note: ★ Available on request if the outdoor unit is above.

6. Example of connection

Example of connection
(Connection of 8 indoor units)

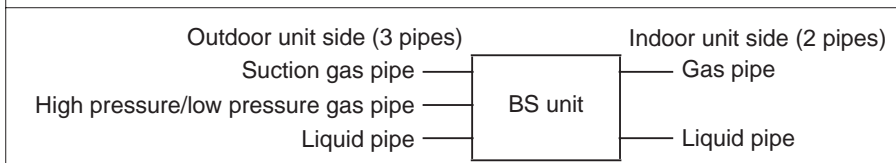

Single outdoor unit system (REYQ8~16)

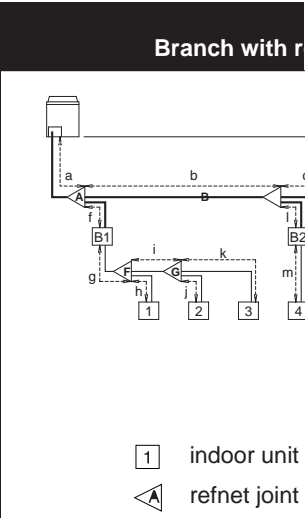

Maximum allowable length	Between outdoor and indoor units	Actual pipe length	Pipe length between outdoor [Example] unit 8: a+b+c+d+e
		Equivalent length	Equivalent pipe length between the BSVQ100 and BSVQ160
		Total extension length	Total piping length from outdoor

Allowable height difference	Between outdoor and indoor units	Difference in height between
	Between indoor and indoor units	Difference in height between

	Actual pipe length	Pipe length from first refrigerant [Example] unit 8: b+c+d+e+s
--	--------------------	---

Refrigerant branch kit selection



Refrigerant branch kits can only be used with R410A.

How to select the refnet joint

When using refnet joints at the first branch counted from the outdoor unit, refer to the following table in accordance with the capacity of the outdoor unit.

Outdoor unit capacity type (Hp)	Refrigerant branch kit name
8+10	KHRQ23M29T
12~16	KHRQ23M64T

For refnet joints other than the first branch, select the total capacity index of all indoor units connected after the refnet joint.

Indoor capacity type	Refrigerant branch kit name
	3 pipes
<200	KHRQ23M20T
200≤x<290	KHRQ23M29T9
290≤x<640	KHRQ23M64T
≥640	KHRQ23M75T

Example of downstream indoor units

[Example] in case of refnet joint C: indoor units 1, 2, 3, 4

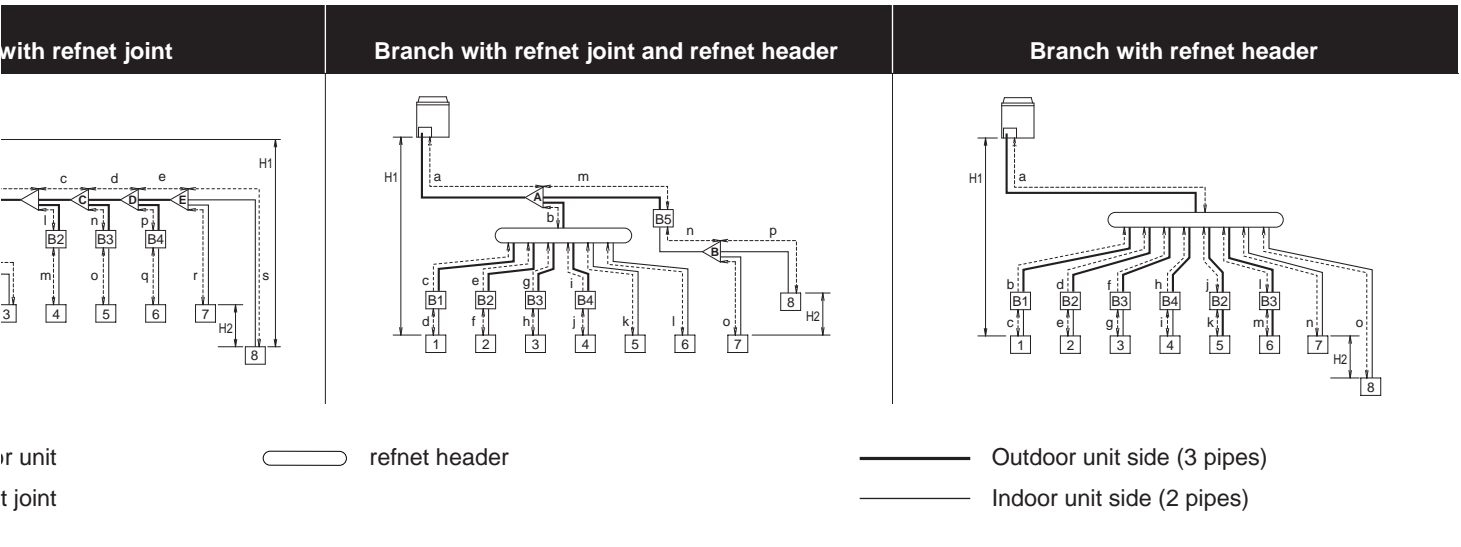

Outdoor and indoor units ≤165 m		
$c+d+e+s \leq 165 \text{ m}$	[Example] unit 6: $a+b+l \leq 165 \text{ m}$, unit 8: $a+m+n+p \leq 165 \text{ m}$	[Example] unit 8: $a+o \leq 165 \text{ m}$
Distance between outdoor and indoor units ≤190 m (Assume equivalent pipe length of the refnet joint to be 0.5 m, of the refnet header to be 1.0 m, of BSVQ160 to be 4 m and of the BSVQ250 to be 6 m (for calculation purposes)) (See note 1 on next page)		
Distance from outdoor unit to all indoor units ≤1000 m		
Distance between outdoor and indoor units ($H1$) ≤50 m (≤40 m if outdoor unit is located in a lower position).		
Distance between adjacent indoor units ($H2$) ≤15 m		
Distance from refrigerant branch kit (either refnet joint or refnet header) to indoor unit ≤40 m (See note 2 on next page)		
$d+e+s \leq 40 \text{ m}$	[Example] unit 6: $b+l \leq 40 \text{ m}$, unit 8: $m+n+p \leq 40 \text{ m}$	[Example] unit 8: $o \leq 40 \text{ m}$

From the outdoor unit side, choose from the table below the outdoor unit (example: refnet joint A).

Refrigerant branch kit name	2 pipes
	KHRQ22M20T
	KHRQ22M29T
	KHRQ22M64T
	KHRQ22M75T





How to select the refnet header

Choose from the following table in accordance with the total capacity of all the indoor units connected below the refnet header.

Note: 250 type indoor unit can not be connected lower than the refnet header.

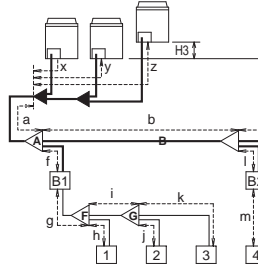
Indoor capacity type	Refrigerant branch kit name	
	3 pipes	2 pipes
<200	KHRQ23M29H	KHRQ22M29H
$200 \leq x < 290$	KHRQ23M29H	KHRQ22M29H
$290 \leq x < 640$	KHRQ23M64H	KHRQ22M64H
≥ 640	KHRQ23M75H	KHRQ22M75H

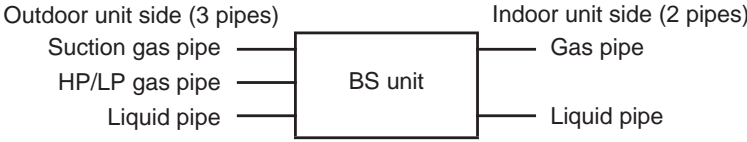
[Example] indoor units 5+6+7+8	[Example] in case of refnet joint B: indoor units 7+8, in case of refnet header: indoor units 1+2+3+4+5+6	[Example] in case of refnet header: indoor units 1+2+3+4+5+6+7+8
--------------------------------	--	--

Example of connection (Connection of 8 indoor units)		Branch with r																			
 <p>Use the outdoor unit multi connection piping kit that is sold separately as an option (BHFQ23P907+1357) for the multi installation of outdoor units. Selection method is as shown in the right table.</p>		 <p>Outdoor units installed in a multiple outdoor unit system (REYQ18~48)</p> <p>① indoor unit  refnet joint</p>																			
 <p>Outdoor unit side (3 pipes) Suction gas pipe HP/LP gas pipe Liquid pipe</p> <p>Indoor unit side (2 pipes) Gas pipe Liquid pipe</p> <p>BS unit</p>																					
<p>Install the joint part (part in the figure) of the outdoor unit multi connection piping kit horizontally with attention to the installation restrictions described in "connecting the refrigerant piping". (*) In case of multi combination, interpret the word "outdoor" as "first outdoor branch".</p>																					
Maximum allowable length	Between outdoor and indoor units	Actual pipe length	Pipe length between outdoor [Example] unit 8: a+b+c+d+e																		
		Equivalent length	Equivalent pipe length between the BSVQ100 and BSVQ1																		
		Total extension length	Total piping length from outdoor																		
	Between the first outdoor unit multi connection piping kit and outdoor unit (in case of a multiple outdoor unit system)	Actual and equivalent pipe length	The actual pipe length from the equivalent pipe length from the																		
Allowable height difference	Between outdoor and indoor units		Difference in height between																		
	Between indoor and indoor units		Difference in height between																		
	Between outdoor and outdoor units		Difference in height between																		
Allowable length after the branch		Actual pipe length	Pipe length from first refrigerant [Example] unit 8: b+c+d+e+s																		
Outdoor unit multi connection piping kit and refrigerant branch kit selection		How to select the refnet joint																			
 <p>Refrigerant branch kits can only be used with R410A.</p>		<p>When using refnet joints at the first branch counted from the following table in accordance with the capacity of the (A).</p> <table border="1"> <thead> <tr> <th>Outdoor unit capacity type (Hp)</th> <th>Refrigerant branch kit name</th> </tr> </thead> <tbody> <tr> <td>8+10</td> <td>KHRQ23M29T</td> </tr> <tr> <td>12~22</td> <td>KHRQ23M64T</td> </tr> <tr> <td>≥24</td> <td>KHRQ23M75T</td> </tr> </tbody> </table> <p>For refnet joints other than the first branch, select the total capacity index of all indoor units connected after</p> <table border="1"> <thead> <tr> <th>Indoor capacity type</th> <th>3 pipes</th> </tr> </thead> <tbody> <tr> <td><200</td> <td>KHRQ23M20T</td> </tr> <tr> <td>200≤x<290</td> <td>KHRQ23M29T9</td> </tr> <tr> <td>290≤x<640</td> <td>KHRQ23M64T</td> </tr> <tr> <td>≥640</td> <td>KHRQ23M75T</td> </tr> </tbody> </table>		Outdoor unit capacity type (Hp)	Refrigerant branch kit name	8+10	KHRQ23M29T	12~22	KHRQ23M64T	≥24	KHRQ23M75T	Indoor capacity type	3 pipes	<200	KHRQ23M20T	200≤x<290	KHRQ23M29T9	290≤x<640	KHRQ23M64T	≥640	KHRQ23M75T
Outdoor unit capacity type (Hp)	Refrigerant branch kit name																				
8+10	KHRQ23M29T																				
12~22	KHRQ23M64T																				
≥24	KHRQ23M75T																				
Indoor capacity type	3 pipes																				
<200	KHRQ23M20T																				
200≤x<290	KHRQ23M29T9																				
290≤x<640	KHRQ23M64T																				
≥640	KHRQ23M75T																				
	Example of downstream indoor units		[Example] in case of refnet joint C: indoor																		

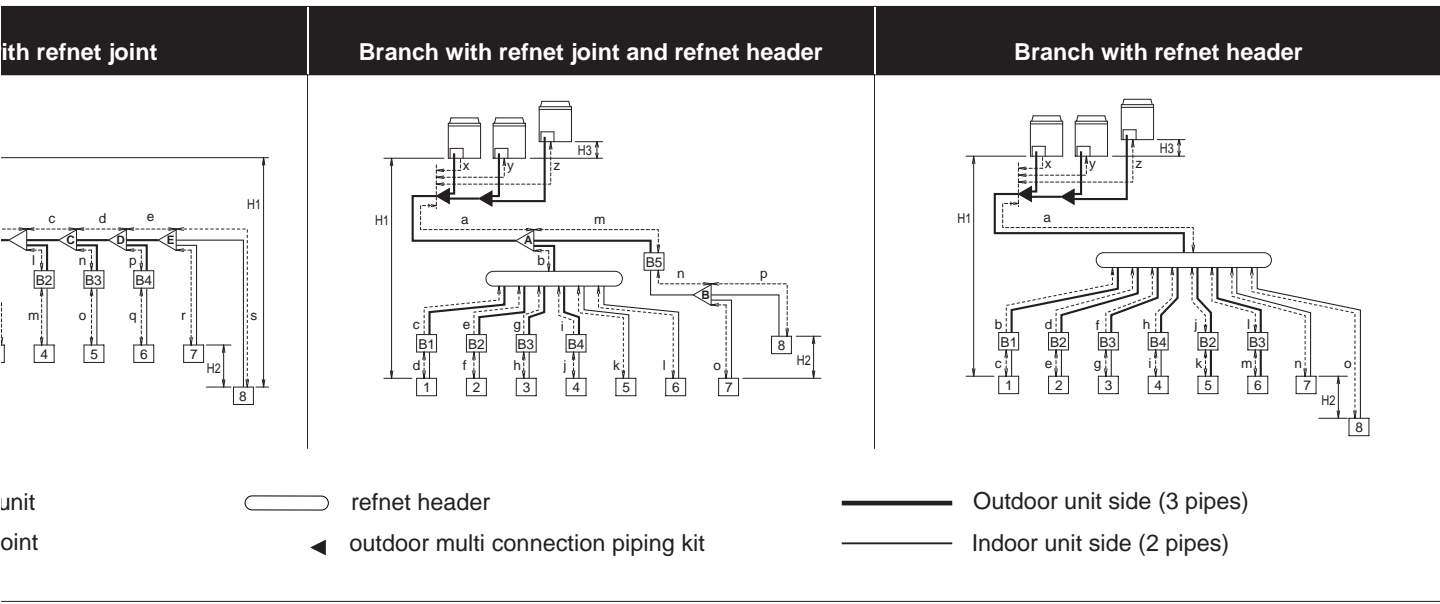

Outdoor unit (*) and indoor units ≤ 165 m
 [Example] unit 6: $a+b+l \leq 165$ m, unit 8: $a+m+n+p \leq 165$ m

Distance between outdoor (*) and indoor units ≤ 190 m (Assume equivalent pipe length of the refnet joint to be 0.5 m, of the refnet header to be 1.0 m, VQ160 to be 4 m and of the BSVQ250 to be 6 m (for calculation purposes)) (See note 1 on next page)

Distance from outdoor (*) to all indoor units ≤ 1000 m

Distance from the first outdoor unit multi connection piping kit to the outdoor unit ≤ 10 m. ($x \leq 10$ m, $y \leq 10$ m, $z \leq 10$ m) The distance from the first outdoor unit multi connection piping kit to the outdoor unit ≤ 13 m. ($x \leq 13$ m, $y \leq 13$ m, $z \leq 13$ m)

Vertical distance between outdoor and indoor units ($H1$) ≤ 50 m (≤ 40 m if outdoor unit is located in a lower position).

Vertical distance between adjacent indoor units ($H2$) ≤ 15 m

Vertical distance between adjacent outdoor units ($H3$) ≤ 5 m

Distance from refrigerant branch kit (either refnet joint or refnet header) to indoor unit ≤ 40 m (See note 2 on next page)

Distance from outdoor unit side, choose from... of the outdoor unit (example: refnet joint)

Refrigerant branch kit name

How to select the refnet header
 Choose from the following table in accordance with the total capacity of all the indoor units connected below the refnet header.
Note: 250 type indoor unit can not be connected lower than the refnet header.

Indoor capacity type	Refrigerant branch kit name	
	3 pipes	2 pipes
<200	KHRQ23M29H	KHRQ22M29H
$200 \leq x < 290$	KHRQ23M29H	KHRQ22M29H
$290 \leq x < 640$	KHRQ23M64H	KHRQ22M64H
≥ 640	KHRQ23M75H	KHRQ22M75H

Select the proper branch kit model based on the... after the refrigerant branch.

2 pipes
KHRQ22M20T
KHRQ22M29T
KHRQ22M64T
KHRQ22M75T

How to choose an outdoor multi connection piping kit (this is required when the system is a multiple outdoor unit system)

Choose from the following table in accordance with the number of outdoor units

Number of outdoor units	Branch kit name
2	BHFQ23P907
3	BHFQ23P1357

[Example] indoor units 5+6+7+8
 in case of refnet joint B: indoor units 7+8,
 in case of refnet header: indoor units 1+2+3+4+5+6
 [Example] in case of refnet header: indoor units 1+2+3+4+5+6+7+8

Pipe size selection

For an outdoor unit multi installation (REYQ18~48P), select the pipe size in accordance with the following figure.

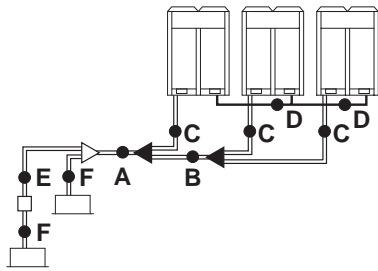

A. Piping between outdoor unit and refrigerant branch kit

B. Piping between outdoor unit multi connection piping units

Choose from the following table in accordance with the outdoor unit total capacity downstream.

Outdoor unit capacity type (Hp)	Piping outer diameter size	
	Suction gas pipe	HP/LP gas pipe
8	19.1	15.9
10	22.2	19.1
12	28.6	19.1
14+16	28.6	22.2
18	28.6	22.2
20+22	28.6	28.6
24	34.9	28.6
26~34	34.9	28.6
36	41.3	28.6
38~48	41.3	34.9

C. Piping between outdoor unit multi connection piping kit and outdoor unit

Choose from the following table in accordance with the capacity type of the outdoor unit.

Outdoor unit capacity type (HP)	Piping outer diameter size	
	Suction gas pipe	HP/LP gas pipe
8+10	22.2	19.1
12	28.6	19.1
14+16	28.6	22.2

How to calculate the additional refrigerant to be charged

Additional refrigerant to be charged R (kg)
R should be rounded off in units of 0.1 kg



The refrigerant charge of the system must be less than 100kg. This means that in case the calculated refrigerant charge is equal to or more than 95kg you must divide your multiple outdoor system into smaller independent systems, each containing less than 95kg refrigerant charge.
For factory charge, refer to the unit name plate.

$$R = \left[[(X1 \times \phi 22.2) \times 0.37] + [(X2 \times \phi 19.1) \times 0.26] + [(X3 \times \phi 15.9) \times 0.18] + [(X4 \times \phi 12.7) \times 0.12] + [(X5 \times \phi 9.5) \times 0.059] + [(X6 \times \phi 6.4) \times 0.022] \right] \times 1.02 + A$$

X_{1...6} = Total length (m) of liquid piping size at ϕa

A = Weight according to table A

B = Weight according to table B in function of indoor unit connection ratio

Note:

When the equivalent pipe length between outdoor and indoor units is 90m or more, the size of the main liquid pipe must be increased. Never increase suction gas pipe and HP/LP gas pipe sizes. Depending on the length of the piping, the capacity may drop, but even in such a case it is possible to increase the size of the main liquid pipe.

Note:

Allowable length after the first refrigerant branch kit to indoor units is 40m or less, however it can be extended.

Required conditions

It is necessary to increase the pipe size of the liquid and suction gas pipe if the pipe length between the first and the final branch kit is over 40m (reducers must be procured on site). Increasing the HP/LP gas pipe size is not allowed.

- If the increased liquid pipe size is larger than the pipe size of the main liquid pipe, then the pipe size of the main liquid pipe needs to be increased as well.

- If the increased suction gas pipe size is larger than the pipe size of the main suction gas pipe, then the allowable length after the first refrigerant branch kit may not be increased to 90m.

Size-up of the main suction gas pipe may affect a good oil return to the outdoor unit due to influence of the HP/LP gas pipe.

For calculation of total extension length, the actual length of above pipes must be doubled (except length of main pipes and of pipes which do not have an increased pipe size).

Indoor unit to the nearest branch kit ≤ 40

The difference between the distance of the outdoor unit to the farthest indoor unit and the distance of the outdoor unit to the nearest indoor unit ≤ 40 m

al capacity type, connected

size (mm)	Liquid pipe
	9.5
	9.5
	12.7
	12.7
	15.9
	15.9
	15.9
	19.1
	19.1
	19.1

outdoor unit
of the connected outdoor unit.

size (mm)	Liquid pipe
	9.5
	12.7
	12.7

E. Piping between refrigerant branch kit and BS unit

Pipe size for direct connection to indoor unit must be the same as the connection size of indoor unit. Choose from the following table in accordance with the indoor unit total capacity type, connected downstream.

Indoor unit capacity type	Piping outer diameter size (mm)		
	Suction gas pipe	HP/LP gas pipe	Liquid pipe
<150	15.9	12.7	9.5
150≤x<200	19.1	15.9	9.5
200≤x<290	22.2	19.1	9.5
290≤x<420	28.6	19.1	12.7
420≤x<640	28.6	28.6	15.9
640≤x<920	34.9	28.6	19.1
≥920	41.3	28.6	19.1

F. Piping between refrigerant branch kit or BS unit and indoor unit

Choose from the following table in accordance with the capacity type of the connected indoor unit.

Indoor unit capacity type	Piping outer diameter size (mm)	
	Suction gas pipe	Liquid pipe
20, 25, 32, 40, 50	12.7	6.4
63, 80, 100, 125	15.9	9.5
200	19.1	9.5
250	22.2	9.5

D. Equalizer piping (outdoor units only)

Piping outer diameter size (mm)
19.1

A+B

REYQ	A
18+20 Hp	1.0 kg
22+24 Hp	1.5 kg
26 Hp	2.0 kg
28+30 Hp	2.5 kg
32-40 Hp	3.0 kg
42 Hp	3.5 kg
44+46 Hp	4.0 kg
48 Hp	4.5 kg

REYQ	B
18-32 Hp	>100% ≤130% 0.5 kg
34-48 Hp	>100% ≤120% >120% ≤130% 1.0 kg

Example for refrigerant branch using refnet joint and refnet header for REYQ34. REYQ34 = REMQ8+REMQ10+REMQ16, the indoor unit connection ratio = 120% and the piping lengths are as below.

a : φ19.1×30 m	f : φ9.5×10 m	k : φ9.5×20 m	p : φ6.4×10 m
b : φ19.1×20 m	g : φ9.5×10 m	l : φ9.5×20 m	r : 12.7×3 m
c : φ9.5×10 m	h : φ9.5×10 m	m : φ9.5×20 m	s : φ9.5×3 m
d : φ9.5×10 m	i : φ9.5×10 m	n : φ9.5×10 m	t : φ9.5×3 m
e : φ9.5×10 m	j : φ9.5×10 m	o : φ6.4×10 m	u : φ15.9×1 m

$$R = [(50 \times 0.26) + [1 \times 0.18] + [3 \times 0.12] + [156 \times 0.059] + [20 \times 0.022]] \times 1.02 + 3.0 + 0.5 = 27.148 \Rightarrow R = 27.1 \text{ kg}$$

REYQ	φ	REYQ	φ
8+10	9.5 → 12.7	18-24	15.9 → 19.1
12-16	12.7 → 15.9	26-48	19.1 → 22.2

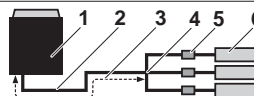

- 1 Outdoor unit
- 2 Main pipes
- 3 Increase only liquid pipe size
- 4 First refrigerant branch kit
- 5 BS unit
- 6 Indoor unit

extended up to 90m if all the following conditions are fulfilled.

Examples drawings	
indoor unit 8: b+c+d+e+f+g+p≤90 m increase the pipe size of b, c, d, e, f, g	Increase the pipe size as follows φ9.5 → φ12.7 φ12.7 → φ15.9 φ15.9 → φ19.1 φ19.1 → φ22.2
a+b*2+c*2+d*2+e*2+f*2+g*2+h+i+j+k+l+m+n+p≤1000 m h, i, j,..... p≤40m	
The most remote indoor unit 8 The nearest indoor unit 1 (a+b+c+d+e+f+g+p)-(a+h)≤40m	<ul style="list-style-type: none"> 1 Outdoor unit 2 Refnet joints (a~g) 3 Indoor units (1~8)

7. Thermistor Resistance / Temperature Characteristics

Indoor unit For air suction R1T
For liquid pipe R2T
For gas pipe R3T

Outdoor unit for fin thermistor R1T

Outdoor unit For outdoor air R1T
For coil R2T
For suction pipe R4T
For Receiver gas pipe R5T
For Receiver outlet liquid pipe R6T

(kΩ)

T°C	0.0
-10	-
-8	-
-6	88.0
-4	79.1
-2	71.1
0	64.1
2	57.8
4	52.3
6	47.3
8	42.9
10	38.9
12	35.3
14	32.1
16	29.2
18	26.6
20	24.3
22	22.2
24	20.3
26	18.5
28	17.0
30	15.6
32	14.2
34	13.1
36	12.0
38	11.1
40	10.3
42	9.5
44	8.8
46	8.2
48	7.6
50	7.0
52	6.7
54	6.0
56	5.5
58	5.2
60	4.79
62	4.46
64	4.15
66	3.87
68	3.61
70	3.37
72	3.15
74	2.94
76	2.75
78	2.51
80	2.41
82	2.26
84	2.12
86	1.99
88	1.87
90	1.76
92	1.65
94	1.55
96	1.46
98	1.38

T°C	0.0	0.5
-20	197.81	192.08
-19	186.53	181.16
-18	175.97	170.94
-17	166.07	161.36
-16	156.80	152.38
-15	148.10	143.96
-14	139.94	136.05
-13	132.28	128.63
-12	125.09	121.66
-11	118.34	115.12
-10	111.99	108.96
-9	106.03	103.18
-8	100.41	97.73
-7	95.14	92.61
-6	90.17	87.79
-5	85.49	83.25
-4	81.08	78.97
-3	76.93	74.94
-2	73.01	71.14
-1	69.32	67.56
0	65.84	64.17
1	62.54	60.96
2	59.43	57.94
3	56.49	55.08
4	53.71	52.38
5	51.09	49.83
6	48.61	47.42
7	46.26	45.14
8	44.05	42.98
9	41.95	40.94
10	39.96	39.01
11	38.08	37.18
12	36.30	35.45
13	34.62	33.81
14	33.02	32.25
15	31.50	30.77
16	30.06	29.37
17	28.70	28.05
18	27.41	26.78
19	26.18	25.59
20	25.01	24.45
21	23.91	23.37
22	22.85	22.35
23	21.85	21.37
24	20.90	20.45
25	20.00	19.56
26	19.14	18.73
27	18.32	17.93
28	17.54	17.17
29	16.80	16.45
30	16.10	15.76

T°C	0.0	0.5
30	16.10	15.76
31	15.43	15.10
32	14.79	14.48
33	14.18	13.88
34	13.59	13.31
35	13.04	12.77
36	12.51	12.25
37	12.01	11.76
38	11.52	11.29
39	11.06	10.84
40	10.63	10.41
41	10.21	10.00
42	9.81	9.61
43	9.42	9.24
44	9.06	8.88
45	8.71	8.54
46	8.37	8.21
47	8.05	7.90
48	7.75	7.60
49	7.46	7.31
50	7.18	7.04
51	6.91	6.78
52	6.65	6.53
53	6.41	6.53
54	6.65	6.53
55	6.41	6.53
56	6.18	6.06
57	5.95	5.84
58	5.74	5.43
59	5.14	5.05
60	4.96	4.87
61	4.79	4.70
62	4.62	4.54
63	4.46	4.38
64	4.30	4.23
65	4.16	4.08
66	4.01	3.94
67	3.88	3.81
68	3.75	3.68
69	3.62	3.56
70	3.50	3.44
71	3.38	3.32
72	3.27	3.21
73	3.16	3.11
74	3.06	3.01
75	2.96	2.91
76	2.86	2.82
77	2.77	2.72
78	2.68	2.64
79	2.60	2.55
80	2.51	2.47

**Outdoor Unit
Thermistors for
Discharge Pipe
(R3T, R31~33T)**

						(kΩ)		
T°C	0.0	0.5	T°C	0.0	0.5	T°C	0.0	0.5
0	640.44	624.65	50	72.32	70.96	100	13.35	13.15
1	609.31	594.43	51	69.64	68.34	101	12.95	12.76
2	579.96	565.78	52	67.06	65.82	102	12.57	12.38
3	552.00	538.63	53	64.60	63.41	103	12.20	12.01
4	525.63	512.97	54	62.24	61.09	104	11.84	11.66
5	500.66	488.67	55	59.97	58.87	105	11.49	11.32
6	477.01	465.65	56	57.80	56.75	106	11.15	10.99
7	454.60	443.84	57	55.72	54.70	107	10.83	10.67
8	433.37	423.17	58	53.72	52.84	108	10.52	10.36
9	413.24	403.57	59	51.98	50.96	109	10.21	10.06
10	394.16	384.98	60	49.96	49.06	110	9.92	9.78
11	376.05	367.35	61	48.19	47.33	111	9.64	9.50
12	358.88	350.62	62	46.49	45.67	112	9.36	9.23
13	342.58	334.74	63	44.86	44.07	113	9.10	8.97
14	327.10	319.66	64	43.30	42.54	114	8.84	8.71
15	312.41	305.33	65	41.79	41.06	115	8.59	8.47
16	298.45	291.73	66	40.35	39.65	116	8.35	8.23
17	285.18	278.80	67	38.96	38.29	117	8.12	8.01
18	272.58	266.51	68	37.63	36.98	118	7.89	7.78
19	260.60	254.72	69	36.34	35.72	119	7.68	7.57
20	249.00	243.61	70	35.11	34.51	120	7.47	7.36
21	238.36	233.14	71	33.92	33.35	121	7.26	7.16
22	228.05	223.08	72	32.78	32.23	122	7.06	6.97
23	218.24	213.51	73	31.69	31.15	123	6.87	6.78
24	208.90	204.39	74	30.63	30.12	124	6.69	6.59
25	200.00	195.71	75	29.61	29.12	125	6.51	6.42
26	191.53	187.44	76	28.64	28.16	126	6.33	6.25
27	183.46	179.57	77	27.69	27.24	127	6.16	6.08
28	175.77	172.06	78	26.79	26.35	128	6.00	5.92
29	168.44	164.90	79	25.91	25.49	129	5.84	5.76
30	161.45	158.08	80	25.07	24.66	130	5.69	5.61
31	154.79	151.57	81	24.26	23.87	131	5.54	5.46
32	148.43	145.37	82	23.48	23.10	132	5.39	5.32
33	142.37	139.44	83	22.73	22.36	133	5.25	5.18
34	136.59	133.79	84	22.01	21.65	134	5.12	5.05
35	131.06	128.39	85	21.31	20.97	135	4.98	4.92
36	125.79	123.24	86	20.63	20.31	136	4.86	4.79
37	120.76	118.32	87	19.98	19.67	137	4.73	4.67
38	115.95	113.62	88	19.36	19.05	138	4.61	4.55
39	111.35	109.13	89	18.75	18.46	139	4.49	4.44
40	106.96	104.84	90	18.17	17.89	140	4.38	4.32
41	102.76	100.73	91	17.61	17.34	141	4.27	4.22
42	98.75	96.81	92	17.07	16.80	142	4.16	4.11
43	94.92	93.06	93	16.54	16.29	143	4.06	4.01
44	91.25	89.47	94	16.04	15.79	144	3.96	3.91
45	87.74	86.04	95	15.55	15.31	145	3.86	3.81
46	84.38	82.75	96	15.08	14.85	146	3.76	3.72
47	81.16	79.61	97	14.62	14.40	147	3.67	3.62
48	78.09	76.60	98	14.18	13.97	148	3.58	3.54
49	75.14	73.71	99	13.76	13.55	149	3.49	3.45
50	72.32	70.96	100	13.35	13.15	150	3.41	3.37

8. Pressure Sensor

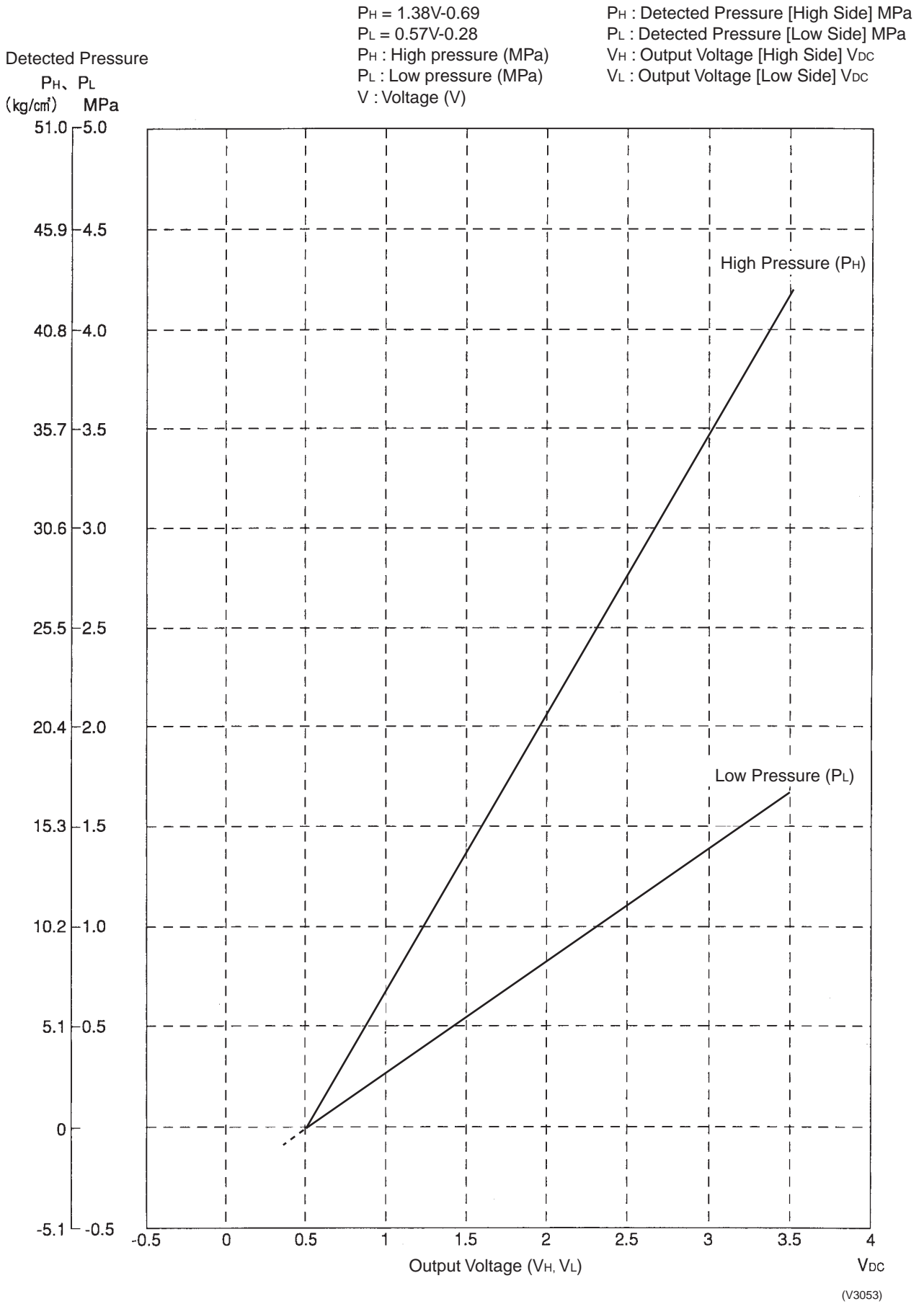

9. Method of Checking the Inverter's Power Transistors and Diode Modules

9.1 Method of Checking the Inverter's Power Transistors and Diode Modules

Checking failures in power semiconductors mounted on inverter PC board

Check the power semiconductors mounted on the inverter PC board by the use of a multiple tester.

<Items to be prepared>

- Multiple tester : Prepare the analog type of multiple tester.
For the digital type of multiple tester, those with diode check function are available for the checking.

<Test points>

- Turn OFF the power supply. Then, after a lapse of 10 minutes or more, make measurement of resistance.

<Preparation>

- To make measurement, disconnect all connectors and terminals.

Inverter PC board

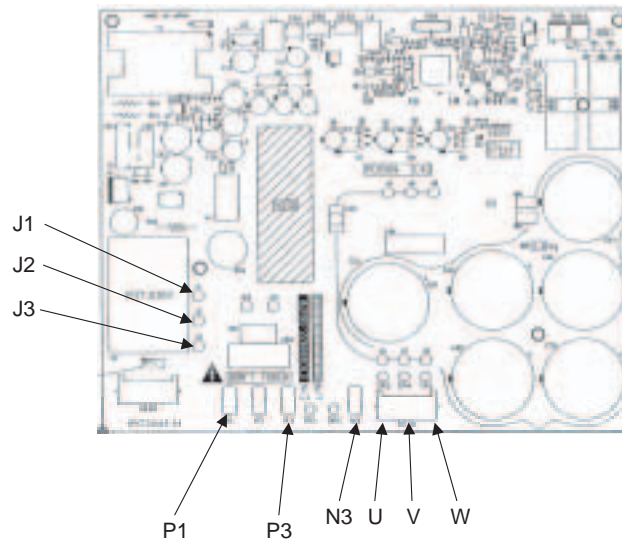

Electronic circuit

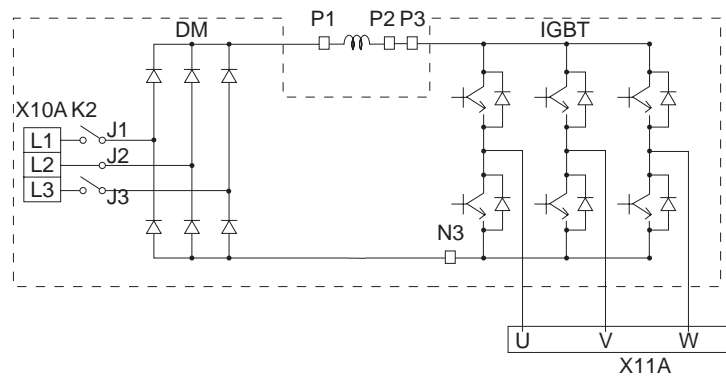

(V2895)

- According to the checking aforementioned, it is probed that the malfunction results from the faulty inverter. The following section describes supposed causes of the faulty inverter.
 - Faulty compressor (ground leakage)
 - Faulty fan motor (ground leakage)
 - Entry of conductive foreign particles
 - Abnormal voltage (e.g. overvoltage, surge (thunder), or unbalanced voltage)

In order to replace the faulty inverter, be sure to check for the points aforementioned.

1. Power module checking

When using the analog type of multiple tester, make measurement in resistance measurement mode in the x1kΩ range.

No.	Measuring point		Criterion	Remark
	+	-		
1	P3	U	2 to 15kΩ	It may take time to determine the resistance due to capacitor charge or else.
2	P3	V		
3	P3	W		
4	U	P3	Not less than 15kΩ (including)	
5	V	P3		
6	W	P3		
7	N3	U		
8	N3	V		
9	N3	W		
10	U	N3	2 to 15kΩ	
11	V	N3		
12	W	N3		

When using the digital type of multiple tester, make measurement in diode check mode ().

No.	Measuring point		Criterion	Remark
	+	-		
1	P3	U	Not less than 1.2V (including)	It may take time to determine the voltage due to capacitor charge or else.
2	P3	V		
3	P3	W		
4	U	P3	0.3 to 0.7V	It may take time to determine the voltage due to capacitor charge or else.
5	V	P3		
6	W	P3		
7	N3	U		
8	N3	V		
9	N3	W		
10	U	N3	Not less than 1.2V (including)	
11	V	N3		
12	W	N3		

2. Diode module checking

When using the analog type of multiple tester, make measurement in resistance measurement mode in the x1kΩ range.

No.	Measuring point		Criterion	Remark
	+	-		
1	P1	J1	2 to 15kΩ	It may take time to determine the resistance due to capacitor charge or else.
2	P1	J2		
3	P1	J3		
4	J1	P1	Not less than 15kΩ (including)	
5	J2	P1		
6	J3	P1		
7	N3	J1		
8	N3	J2		
9	N3	J3		
10	J1	N3	2 to 15kΩ	
11	J2	N3		
12	J3	N3		

When using the digital type of multiple tester, make measurement in diode check mode ().

No.	Measuring point		Criterion	Remark
	+	-		
1	P1	J1	Not less than 1.2V (including)	It may take time to determine the voltage due to capacitor charge or else.
2	P1	J2		
3	P1	J3		
4	J1	P1	0.3 to 0.7V	It may take time to determine the voltage due to capacitor charge or else.
5	J2	P1		
6	J3	P1		
7	N3	J1		
8	N3	J2		
9	N3	J3		
10	J1	N3	Not less than 1.2V (including)	
11	J2	N3		
12	J3	N3		

Part 8

Precautions for New Refrigerant (R-410A)

1. Precautions for New Refrigerant (R-410A)	426
1.1 Outline	426
1.2 Refrigerant Cylinders.....	428
1.3 Service Tools.....	429

1. Precautions for New Refrigerant (R-410A)

1.1 Outline

1.1.1 About Refrigerant R-410A

- Characteristics of new refrigerant, R-410A
 1. Performance
Almost the same performance as R-22 and R-407C
 2. Pressure
Working pressure is approx. 1.4 times more than R-22 and R-407C.
 3. Refrigerant composition
Few problems in composition control, since it is a Quasi-azeotropic mixture refrigerant.

Refrigerant name	HFC units (Units using new refrigerants)		HCFC units
	R-407C	R-410A	R-22
Composing substances	Non-azeotropic mixture of HFC32, HFC125 and HFC134a (*1)	Quasi-azeotropic mixture of HFC32 and JFC125 (*1)	Single-component refrigerant
Design pressure	3.2 MPa (gauge pressure) = 32.6 kgf/cm ²	4.0 MPa (gauge pressure) = 40.8 kgf/cm ²	2.75MPa (gauge pressure) = 28.0 kgf/cm ²
Refrigerant oil	Synthetic oil (Ether)		Mineral oil (Suniso)
Ozone destruction factor (ODP)	0	0	0.05
Combustibility	None	None	None
Toxicity	None	None	None

- ★1. Non-azeotropic mixture refrigerant: mixture of two or more refrigerants having different boiling points.
- ★2. Quasi-azeotropic mixture refrigerant: mixture of two or more refrigerants having similar boiling points.
- ★3. The design pressure is different at each product. Please refer to the installation manual for each product.
(Reference) 1 MPa ≒ 10.19716 kgf / cm²

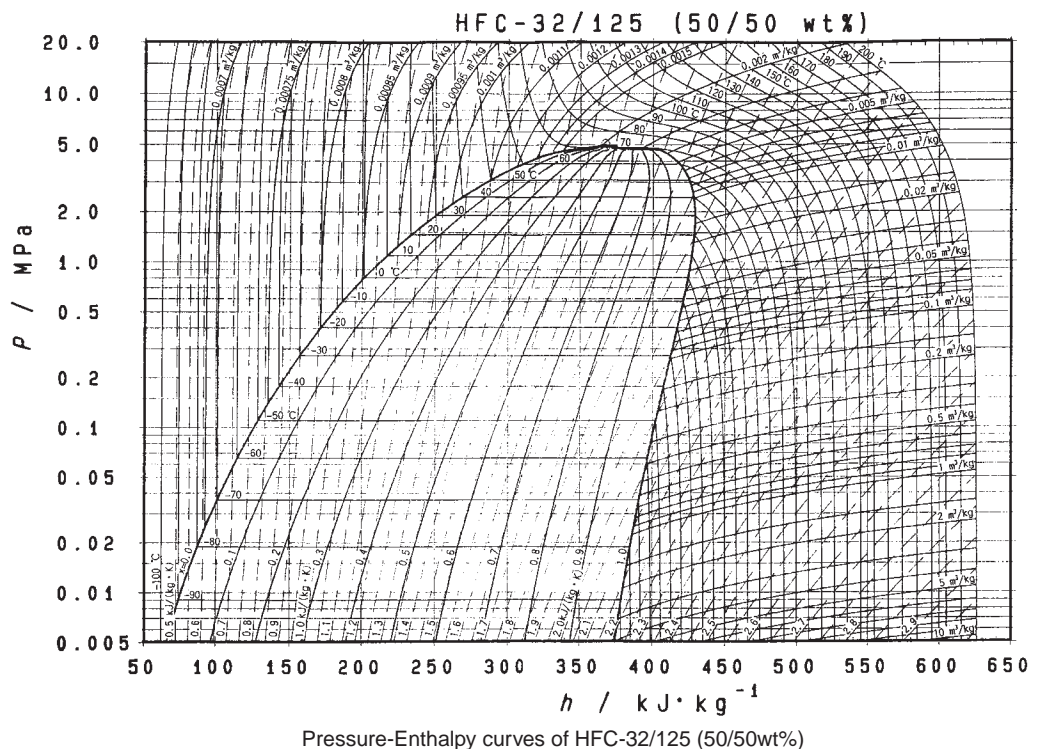

■ Thermodynamic characteristic of R-410A

DAIREP ver2.0

Temperature (°C)	Steam pressure (kPa)		Density (kg/m ³)		Specific heat at constant pressure (kJ/kgK)		Specific enthalpy (kJ/kg)		Specific entropy (kJ/KgK)	
	Liquid	Vapor	Liquid	Vapor	Liquid	Vapor	Liquid	Vapor	Liquid	Vapor
-70	36.13	36.11	1410.7	1.582	1.372	0.695	100.8	390.6	0.649	2.074
-68	40.83	40.80	1404.7	1.774	1.374	0.700	103.6	391.8	0.663	2.066
-66	46.02	45.98	1398.6	1.984	1.375	0.705	106.3	393.0	0.676	2.058
-64	51.73	51.68	1392.5	2.213	1.377	0.710	109.1	394.1	0.689	2.051
-62	58.00	57.94	1386.4	2.463	1.378	0.715	111.9	395.3	0.702	2.044
-60	64.87	64.80	1380.2	2.734	1.379	0.720	114.6	396.4	0.715	2.037
-58	72.38	72.29	1374.0	3.030	1.380	0.726	117.4	397.6	0.728	2.030
-56	80.57	80.46	1367.8	3.350	1.382	0.732	120.1	398.7	0.741	2.023
-54	89.49	89.36	1361.6	3.696	1.384	0.737	122.9	399.8	0.754	2.017
-52	99.18	99.03	1355.3	4.071	1.386	0.744	125.7	400.9	0.766	2.010
-51.58	101.32	101.17	1354.0	4.153	1.386	0.745	126.3	401.1	0.769	2.009
-50	109.69	109.51	1349.0	4.474	1.388	0.750	128.5	402.0	0.779	2.004
-48	121.07	120.85	1342.7	4.909	1.391	0.756	131.2	403.1	0.791	1.998
-46	133.36	133.11	1336.3	5.377	1.394	0.763	134.0	404.1	0.803	1.992
-44	146.61	146.32	1330.0	5.880	1.397	0.770	136.8	405.2	0.816	1.987
-42	160.89	160.55	1323.5	6.419	1.401	0.777	139.6	406.2	0.828	1.981
-40	176.24	175.85	1317.0	6.996	1.405	0.785	142.4	407.3	0.840	1.976
-38	192.71	192.27	1310.5	7.614	1.409	0.792	145.3	408.3	0.852	1.970
-36	210.37	209.86	1304.0	8.275	1.414	0.800	148.1	409.3	0.864	1.965
-34	229.26	228.69	1297.3	8.980	1.419	0.809	150.9	410.2	0.875	1.960
-32	249.46	248.81	1290.6	9.732	1.424	0.817	153.8	411.2	0.887	1.955
-30	271.01	270.28	1283.9	10.53	1.430	0.826	156.6	412.1	0.899	1.950
-28	293.99	293.16	1277.1	11.39	1.436	0.835	159.5	413.1	0.911	1.946
-26	318.44	317.52	1270.2	12.29	1.442	0.844	162.4	414.0	0.922	1.941
-24	344.44	343.41	1263.3	13.26	1.448	0.854	165.3	414.9	0.934	1.936
-22	372.05	370.90	1256.3	14.28	1.455	0.864	168.2	415.7	0.945	1.932
-20	401.34	400.06	1249.2	15.37	1.461	0.875	171.1	416.6	0.957	1.927
-18	432.36	430.95	1242.0	16.52	1.468	0.886	174.1	417.4	0.968	1.923
-16	465.20	463.64	1234.8	17.74	1.476	0.897	177.0	418.2	0.980	1.919
-14	499.91	498.20	1227.5	19.04	1.483	0.909	180.0	419.0	0.991	1.914
-12	536.58	534.69	1220.0	20.41	1.491	0.921	182.9	419.8	1.003	1.910
-10	575.26	573.20	1212.5	21.86	1.499	0.933	185.9	420.5	1.014	1.906
-8	616.03	613.78	1204.9	23.39	1.507	0.947	189.0	421.2	1.025	1.902
-6	658.97	656.52	1197.2	25.01	1.516	0.960	192.0	421.9	1.036	1.898
-4	704.15	701.49	1189.4	26.72	1.524	0.975	195.0	422.6	1.048	1.894
-2	751.64	748.76	1181.4	28.53	1.533	0.990	198.1	423.2	1.059	1.890
0	801.52	798.41	1173.4	30.44	1.543	1.005	201.2	423.8	1.070	1.886
2	853.87	850.52	1165.3	32.46	1.552	1.022	204.3	424.4	1.081	1.882
4	908.77	905.16	1157.0	34.59	1.563	1.039	207.4	424.9	1.092	1.878
6	966.29	962.42	1148.6	36.83	1.573	1.057	210.5	425.5	1.103	1.874
8	1026.5	1022.4	1140.0	39.21	1.584	1.076	213.7	425.9	1.114	1.870
10	1089.5	1085.1	1131.3	41.71	1.596	1.096	216.8	426.4	1.125	1.866
12	1155.4	1150.7	1122.5	44.35	1.608	1.117	220.0	426.8	1.136	1.862
14	1224.3	1219.2	1113.5	47.14	1.621	1.139	223.2	427.2	1.147	1.859
16	1296.2	1290.8	1104.4	50.09	1.635	1.163	226.5	427.5	1.158	1.855
18	1371.2	1365.5	1095.1	53.20	1.650	1.188	229.7	427.8	1.169	1.851
20	1449.4	1443.4	1085.6	56.48	1.666	1.215	233.0	428.1	1.180	1.847
22	1530.9	1524.6	1075.9	59.96	1.683	1.243	236.4	428.3	1.191	1.843
24	1615.8	1609.2	1066.0	63.63	1.701	1.273	239.7	428.4	1.202	1.839
26	1704.2	1697.2	1055.9	67.51	1.721	1.306	243.1	428.6	1.214	1.834
28	1796.2	1788.9	1045.5	71.62	1.743	1.341	246.5	428.6	1.225	1.830
30	1891.9	1884.2	1034.9	75.97	1.767	1.379	249.9	428.6	1.236	1.826
32	1991.3	1983.2	1024.1	80.58	1.793	1.420	253.4	428.6	1.247	1.822
34	2094.5	2086.2	1012.9	85.48	1.822	1.465	256.9	428.4	1.258	1.817
36	2201.7	2193.1	1001.4	90.68	1.855	1.514	260.5	428.3	1.269	1.813
38	2313.0	2304.0	989.5	96.22	1.891	1.569	264.1	428.0	1.281	1.808
40	2428.4	2419.2	977.3	102.1	1.932	1.629	267.8	427.7	1.292	1.803
42	2548.1	2538.6	964.6	108.4	1.979	1.696	271.5	427.2	1.303	1.798
44	2672.2	2662.4	951.4	115.2	2.033	1.771	275.3	426.7	1.315	1.793
46	2800.7	2790.7	937.7	122.4	2.095	1.857	279.2	426.1	1.327	1.788
48	2933.7	2923.6	923.3	130.2	2.168	1.955	283.2	425.4	1.339	1.782
50	3071.5	3061.2	908.2	138.6	2.256	2.069	287.3	424.5	1.351	1.776
52	3214.0	3203.6	892.2	147.7	2.362	2.203	291.5	423.5	1.363	1.770
54	3361.4	3351.0	875.1	157.6	2.493	2.363	295.8	422.4	1.376	1.764
56	3513.8	3503.5	856.8	168.4	2.661	2.557	300.3	421.0	1.389	1.757
58	3671.3	3661.2	836.9	180.4	2.883	2.799	305.0	419.4	1.403	1.749
60	3834.1	3824.2	814.9	193.7	3.191	3.106	310.0	417.6	1.417	1.741
62	4002.1	3992.7	790.1	208.6	3.650	3.511	315.3	415.5	1.433	1.732
64	4175.7	4166.8	761.0	225.6	4.415	4.064	321.2	413.0	1.450	1.722

1.2 Refrigerant Cylinders

- Cylinder specifications
 - The cylinder is painted refrigerant color (pink).
 - The cylinder valve is equipped with a siphon tube.

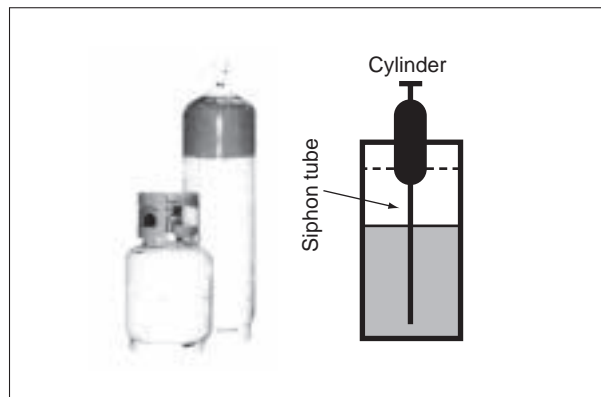

Refrigerant can be charged in liquid state with cylinder in upright position.

Caution: Do not lay cylinder on its side during charging, since it cause refrigerant in gas state to enter the system.

■ Handling of cylinders

(1) Laws and regulations

R-410A is liquefied gas, and the High-Pressure Gas Safety Law must be observed in handling them. Before using, refer to the High-Pressure Gas Safety Law.

The Law stipulates standards and regulations that must be followed to prevent accidents with high-pressure gases. Be sure to follow the regulations.

(2) Handling of vessels

Since R-410A is high-pressure gas, it is contained in high-pressure vessels.

Although those vessels are durable and strong, careless handling can cause damage that can lead to unexpected accidents. Do not drop vessels, let them fall, apply impact or roll them on the ground.

(3) Storage

Although R-410A is not flammable, it must be stored in a well-ventilated, cool, and dark place in the same way as any other high-pressure gases.

It should also be noted that high-pressure vessels are equipped with safety devices that releases gas when the ambient temperature reaches more than a certain level (fusible plug melts) and when the pressure exceeds a certain level (spring-type safety valve operates).

1.3 Service Tools

R-410A is used under higher working pressure, compared to previous refrigerants (R-22,R-407C). Furthermore, the refrigerating machine oil has been changed from Suniso oil to Ether oil, and if oil mixing is occurred, sludge results in the refrigerants and causes other problems. Therefore, gauge manifolds and charge hoses that are used with a previous refrigerant (R-22,R-407C) can not be used for products that use new refrigerants.

Be sure to use dedicated tools and devices.

■ Tool compatibility

Tool	Compatibility			Reasons for change
	HFC		HCFC	
	R-410A	R-407C	R-22	
Gauge manifold Charge hose	×			<ul style="list-style-type: none"> Do not use the same tools for R-22 and R-410A. Thread specification differs for R-410A and R-407C.
Charging cylinder	×		○	<ul style="list-style-type: none"> Weighting instrument used for HFCs.
Gas detector	○		×	<ul style="list-style-type: none"> The same tool can be used for HFCs.
Vacuum pump (pump with reverse flow preventive function)		○		<ul style="list-style-type: none"> To use existing pump for HFCs, vacuum pump adapter must be installed.
Weighting instrument		○		
Charge mouthpiece		×		<ul style="list-style-type: none"> Seal material is different between R-22 and HFCs. Thread specification is different between R-410A and others.
Flaring tool (Clutch type)		○		<ul style="list-style-type: none"> For R-410A, flare gauge is necessary.
Torque wrench		○		<ul style="list-style-type: none"> Torque-up for 1/2 and 5/8
Pipe cutter		○		
Pipe expander		○		
Pipe bender		○		
Pipe assembling oil		×		<ul style="list-style-type: none"> Due to refrigerating machine oil change. (No Suniso oil can be used.)
Refrigerant recovery device	Check your recovery device.			
Refrigerant piping	See the chart below.			<ul style="list-style-type: none"> Only φ19.1 is changed to 1/2H material while the previous material is "O".

As for the charge mouthpiece and packing, 1/2UNF20 is necessary for mouthpiece size of charge hose.

■ Copper tube material and thickness

Pipe size	Ve-up		Ve-upII	
	R-407C		R-410A	
	Material	Thickness t (mm)	Material	Thickness t (mm)
φ6.4	O	0.8	O	0.8
φ9.5	O	0.8	O	0.8
φ12.7	O	0.8	O	0.8
φ15.9	O	1.0	O	1.0
φ19.1	O	1.0	1/2H	1.0
φ22.2	1/2H	1.0	1/2H	1.0
φ25.4	1/2H	1.0	1/2H	1.0
φ28.6	1/2H	1.0	1/2H	1.0
φ31.8	1/2H	1.2	1/2H	1.1
φ38.1	1/2H	1.4	1/2H	1.4
φ44.5	1/2H	1.6	1/2H	1.6

* O: Soft (Annealed)
H: Hard (Drawn)

1. Flaring tool



■ Specifications

- Dimension A

Unit:mm

Nominal size	Tube O.D. Do	A ⁺⁰ _{-0.4}	
		Class-2 (R-410A)	Class-1 (Conventional)
1/4	6.35	9.1	9.0
3/8	9.52	13.2	13.0
1/2	12.70	16.6	16.2
5/8	15.88	19.7	19.4
3/4	19.05	24.0	23.3

■ Differences

- Change of dimension A

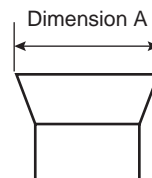

For class-1: R-407C
For class-2: R-410A

Conventional flaring tools can be used when the work process is changed.

(change of work process)

Previously, a pipe extension margin of 0 to 0.5mm was provided for flaring. For R-410A air conditioners, perform pipe flaring with a pipe extension margin of 1.0 to 1.5mm.

(For clutch type only)

Conventional tool with pipe extension margin adjustment can be used.

2. Torque wrench



■ Specifications

- Dimension B

Unit:mm

Nominal size	Class-1	Class-2	Previous
1/2	24	26	24
5/8	27	29	27

No change in tightening torque
 No change in pipes of other sizes

■ Differences

- Change of dimension B
 Only 1/2", 5/8" are extended

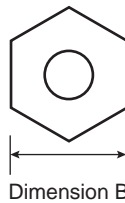

For class-1: R-407C
 For class-2: R-410A

3. Vacuum pump with check valve

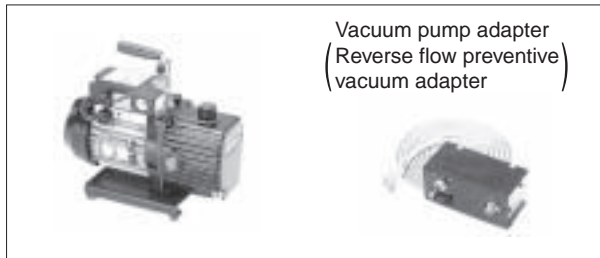

Vacuum pump adapter
 (Reverse flow preventive)
 vacuum adapter

■ Specifications

- Discharge speed
 50 l/min (50Hz)
 60 l/min (60Hz)
- Suction port UNF7/16-20(1/4 Flare)
 UNF1/2-20(5/16 Flare) with adapter
- Maximum degree of vacuum
 Select a vacuum pump which is able to keep the vacuum degree of the system in excess of -100.7 kPa (5 torr - 755 mmHg).

■ Differences

- Equipped with function to prevent reverse oil flow
- Previous vacuum pump can be used by installing adapter.

4. Leak tester



- Specifications
 - Hydrogen detecting type, etc.
 - Applicable refrigerants
R-410A, R-407C, R-404A, R-507A, R-134a, etc.
- Differences
 - Previous testers detected chlorine. Since HFCs do not contain chlorine, new tester detects hydrogen.

5. Refrigerant oil (Air compal)



- Specifications
 - Contains synthetic oil, therefore it can be used for piping work of every refrigerant cycle.
 - Offers high rust resistance and stability over long period of time.
- Differences
 - Can be used for R-410A and R-22 units.

6. Gauge manifold for R-410A

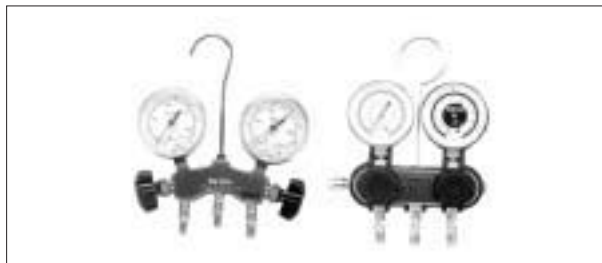

- Specifications
 - High pressure gauge
- 0.1 to 5.3 MPa (-76 cmHg to 53 kg/cm²)
 - Low pressure gauge
- 0.1 to 3.8 MPa (-76 cmHg to 38 kg/cm²)
 - 1/4" → 5/16" (2min → 2.5min)
 - No oil is used in pressure test of gauges.
→ For prevention of contamination

- Temperature scale indicates the relationship between pressure and temperature in gas saturated state.
- Differences
 - Change in pressure
 - Change in service port diameter

7. Charge hose for R-410A

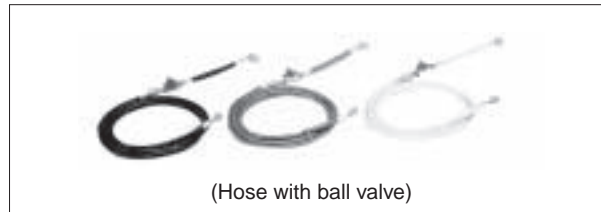

- Specifications
 - Working pressure 5.08 MPa (51.8 kg/cm²)
 - Rupture pressure 25.4 MPa (259 kg/cm²)
 - Available with and without hand-operate valve that prevents refrigerant from outflow.
- Differences
 - Pressure proof hose
 - Change in service port diameter
 - Use of nylon coated material for HFC resistance

8. Charging cylinder



- Specifications
 - Use weigher for refrigerant charge listed below to charge directly from refrigerant cylinder.
- Differences
 - The cylinder can not be used for mixed refrigerant since mixing ratio is changed during charging.

When R-410A is charged in liquid state using charging cylinder, foaming phenomenon is generated inside charging cylinder.

9. Weigher for refrigerant charge



- Specifications
 - High accuracy
 - TA101A (for 10-kg cylinder) = ± 2 g
 - TA101B (for 20-kg cylinder) = ± 5 g
 - Equipped with pressure-resistant sight glass to check liquid refrigerant charging.
 - A manifold with separate ports for HFCs and previous refrigerants is equipped as standard accessories.
- Differences
 - Measurement is based on weight to prevent change of mixing ratio during charging.

10. Charge mouthpiece



- Specifications
 - For R-410A, 1/4" → 5/16" (2min → 2.5min)
 - Material is changed from CR to H-NBR.
- Differences
 - Change of thread specification on hose connection side (For the R-410A use)
 - Change of sealer material for the HFCs use.

Index

A	
A0	266
A1	267
A3	268
A6	270, 272, 273
A7	274
A9	276, 278
Abnormal Discharge Pipe Temperature	299
Abnormal Outdoor Fan Motor Signal	304
Actuation of High Pressure Switch	287
Actuation of Low Pressure Sensor	289
Address Duplication of Centralized Controller	365
Address Duplication, Improper Setting	376
AF	280
AJ	281
B	
Broken Wire Check of the Connecting Wires	388
C	
C4	282
C5	283
C9	284
Check 1	383
Check 2	383
Check 3	384
Check 4	385
Check 5	386
Check 6	387
Check 7	388
Check 8	389
Check 9	390
Check 10	391
Check 11	392
Check 12	393
Check 13	394
Check 14	395
Check 15	396
Check for Causes of Drop in Low Pressure	387
Check for Causes of Rise in High Pressure	386
Check for Causes of Wet Operation.	391
Check for Overcharge of Refrigerant.	392
Check for Shortage of Refrigerant.	393
Check on Connector of Fan Motor (Power Supply Cable)	383
Check Operation not Executed	346
Check the Factors of Overheat Operation	384
CJ	285
Concept of Inverter-related Malfunction Codes ...	396
Cooling only/Heat-pump setting	217
Current Sensor Malfunction	307
D	
Defective Inverter PC Board	319
Detailed Explanation of Setting Modes	207
Display "Under Centralized Control" Blinks (Repeats Double Blink)	382
Display "Under Centralized Control" Blinks (Repeats Single Blink)	379
Drain Level above Limit	280
E	
E1	286
E3	287
E4	289
E5	291
E6	293
E7	294
E9	297
Electronic Expansion Valve Malfunction / Dust Clogging	276
Error of External Protection Device	266
F	
F3	299
F6	301
F9	302
Fan Motor (M1F) Lock, Overload	270
Faulty Field Setting after Replacing Main PC Board or Faulty Combination of PC Board ...	338
Functional Parts Layout	70
REMQ10P, 12P	73
REMQ14P, 16P	74
REMQ8P	72
REYQ14P, 16P	71
REYQ8P, 10P, 12P	70
G	
Gas Shortage Alert	340
H	
H7	304
H9	306
Heat Exchanger Control	118
I	
Improper Combination of Indoor and Outdoor Units, Indoor Units and Remote Control	359
Improper Combination of Optional Controllers for Centralized Control	374
Inverter Compressor Motor Lock	291
Inverter Compressor Starting Failure	328
Inverter Over-Ripple Protection	334
J	
J2	307
J3	308
J4	309
J5	310
J6	311

J7	312	Malfunction of Thermistor (R4T or R12T) for Outdoor Unit Heat Exchanger	311
J9	314	Malfunction of Thermistor (R8T or R10T) for Suction Pipe	310
JA	315	Malfunction of Thermostat Sensor in Remote Control	285
JC	317	Malfunction of Transmission between Centralized Controller and Indoor Unit	366
L		Malfunction of Transmission between Indoor and Outdoor Units in the Same System	358
L1	319	Malfunction of Transmission between Indoor Units	347
L4	321	Malfunction of Transmission between Inverter and Control PC Board	331
L5	324	Malfunction of Transmission between Main and Sub Remote Controls	357
L8	326	Malfunction of Transmission between Optional Controllers for Centralized Control	373
L9	328	Malfunction of Transmission between Remote Control and Indoor Unit	350
LC	331	Master Unit Central Connector Setting Table	389
List of Electrical and Functional Parts	435	Master-Slave Unit Setting Table	390
Indoor Unit	439	MC	376
Outdoor Unit	435	Microcomputer Normal Monitor	201
List of Inverter-related Malfunction Codes	395	Mode Setting Switch	201
Local setting switch	201	Model Setting	217
M		Momentary Overcurrent of Inverter Compressor	324, 326
M1	372	Monitor Mode	228
M8	373	Motor Side Connectors	383
MA	374	O	
Malfunction Code Indication by Outdoor Unit PC Board	262	Operation Lamp Blinks	377
Malfunction of BS Unit Electronic Expansion Valve	302	Outdoor Unit PC Board Layout	201
Malfunction of Capacity Determination Device	281	Overload / Overcurrent / Lock of Indoor Unit Fan Motor	273
Malfunction of Discharge Pipe Thermistor (R31T, R32T, R33T)	308	P	
Malfunction of Drain Level Control System (S1L)	268	P1	334
Malfunction of Electronic Expansion Valve Coil	278	P4	336
Malfunction of High Pressure Sensor	315	PC Board Defect	267, 286, 372
Malfunction of Indoor Unit Fan Motor	272	Piping Diagrams	398
Malfunction of Inverter Radiating Fin Temperature Rise	321	Indoor Unit	403
Malfunction of Inverter Radiating Fin Temperature Rise Sensor	336	Outdoor Unit	398
Malfunction of Liquid Pipe Thermistor 1 (R6T, R9T or R14T)	312	Piping Installation Point	448
Malfunction of Liquid Pipe Thermistor 2 (R7T or R15T)	313	The Example of a Wrong Pattern	449
Malfunction of Low Pressure Sensor	317	PJ	338
Malfunction of Moving Part of Electronic Expansion Valve (Y1E~Y5E)	297	Power Supply Insufficient or Instantaneous Failure	343
Malfunction of Outdoor Unit Fan Motor	294	Power Supply Specification	217
Malfunction of Subcooling Heat Exchanger Gas Pipe Thermistor (R5T or R13T)	314	Power Transistor Check	385
Malfunction of Swing Flap Motor (M1S)	274	R	
Malfunction of System, Refrigerant System Address Undefined	370	Refrigerant Circuit	58
Malfunction of Temperature Sensor for Heat Exchanger Gas (R2T or R11T)	309	BS Unit Functional Parts	68
Malfunction of Thermistor (R1T) for Outdoor Air	306	REMQ10P, 12P (Multi 10, 12HP)	64
Malfunction of Thermistor (R1T) for Suction Air	284	REMQ14P, 16P (Multi 14, 16HP)	66
Malfunction of Thermistor (R2T) for Heat Exchanger	282	REMQ8P (Multi 8HP)	62
Malfunction of Thermistor (R3T) for Gas Pipes	283	REYQ14P, 16P	60
		REYQ8P, 10P, 12P	58
		Refrigerant Flow for Each Operation Mode	75

REYQ14P, 16P83
 REYQ18P, 20P91
 REYQ8P, 10P, 12P75
 Refrigerant Overcharged301
 Reverse Phase, Open Phase342

S

Set Model Display (LED)201
 Setting at Replacement by Spare PC Board217
 Setting by Push Button Switches221
 Setting Mode 1223
 Setting Mode 2224
 Startup Control119
 STD Compressor Motor Overcurrent/Lock293
 Symptom-based Troubleshooting248
 System is not Set yet369

T

The Example of a Wrong Pattern449
 Transmission Failure (Across Outdoor Units)351
 Troubleshooting
 (OP: Central Remote Control)372
 Troubleshooting
 (OP: Unified ON/OFF Controller)377

U

U0340
 U1342
 U2343
 U3346
 U4347
 U5350
 U7351
 U8357
 U9358
 UA359
 UC365
 UE366
 UF369
 UH370
 Unit Allocation Setting217

V

Vacuuming and Dehydration Procedure394

W

Wiring Diagrams for Reference
 Field Wiring415
 Indoor Unit418
 Outdoor Unit410

Drawings & Flow Charts

A			
Abnormal Discharge Pipe Temperature	299		
Abnormal Outdoor Fan Motor Signal	304		
Actuation of High Pressure Switch	287		
Actuation of Low Pressure Sensor	289		
Address Duplication of Centralized Controller	365		
Address Duplication, Improper Setting	376		
B			
Broken Wire Check of the Connecting Wires	388		
C			
Centralized Control Group No. Setting	212		
BRC1C Type	212		
BRC4C Type	212		
BRC7C Type	212		
BRC7E Type	212		
Group No. Setting Example	213		
Check 1	383		
Check 2	383		
Check 3	384		
Check 4	385		
Check 5	386		
Check 6	387		
Check 7	388		
Check 8	389		
Check 9	390		
Check 10	391		
Check 11	392		
Check 12	393		
Check 13	394		
Check 14	395		
Check 15	396		
Check for Causes of Drop in Low Pressure	387		
Check for Causes of Rise in High Pressure	386		
Check for Causes of Wet Operation	391		
Check for Overcharge of Refrigerant	392		
Check for Shortage of Refrigerant	393		
Check on Connector of Fan Motor (Power Supply Cable)	383		
CHECK OPERATION FUNCTION	238		
Check Operation not Executed	346		
Check the Factors of Overheat Operation	384		
Concept of Inverter-related Malfunction Codes	396		
Contents of Control Modes	213		
How to Select Operation Mode	214		
Current Sensor Malfunction	307		
D			
Defective Inverter PC Board	319		
Detailed Setting Procedure of Low Noise Operation and Demand Control	235		
Discharge Pipe Protection Control	136		
Display “Under Centralized Control” Blinks (Repeats Double Blink)	382		
		Display “Under Centralized Control” Blinks (Repeats Single Blink)	379
		Drain Level above Limit	280
		Drain Pump Control	147
		When the Float Switch is Tripped and “AF” is Displayed on the Remote Controller	148
		When the Float Switch is Tripped During Heating Operation	148
		When the Float Switch is Tripped while the Cooling Thermostat is OFF	147
		When the Float Switch is Tripped While the Cooling Thermostat is ON	147
		E	
		Electronic Expansion Valve Malfunction / Dust Clogging	276
		Emergency Operation	239
		Cancel of Emergency Operation	241
		Details of operation	239
		Error of External Protection Device	266
		EXAMPLE OF TRANSMISSION LINE CONNECTION	230
		F	
		Fan Motor (M1F) Lock, Overload	270
		Faulty Field Setting after Replacing Main PC Board or Faulty Combination of PC Board	338
		Field Setting from Outdoor Unit	215
		Mode Changing Procedure	221, 222
		Setting by Dip Switches	217
		Freeze Prevention	150
		Functional Parts Layout	70
		REMQ10P, 12P	73
		REMQ14P, 16P	74
		REMQ8P	72
		REYQ14P, 16P	71
		REYQ8P, 10P, 12P	70
		G	
		Gas Shortage Alert	340
		H	
		Heat Exchanger Control	118
		High Pressure Protection Control	132
		I	
		Improper Combination of Indoor and Outdoor Units, Indoor Units and Remote Control	359
		Improper Combination of Optional Controllers for Centralized Control	374
		Inspection Mode	256
		Inverter Compressor Motor Lock	291
		Inverter Compressor Starting Failure	328
		Inverter Over-Ripple Protection	334

Inverter Protection Control137

L

List of Inverter-related Malfunction Codes395

Louver Control for Preventing Ceiling Dirt154

Low Pressure Protection Control134

M

Malfunction Code Indication by Outdoor Unit PC Board262

Malfunction of BS Unit Electronic Expansion Valve302

Malfunction of Capacity Determination Device281

Malfunction of Discharge Pipe Thermistor (R31T, R32T, R33T)308

Malfunction of Drain Level Control System (S1L)268

Malfunction of Electronic Expansion Valve Coil ...278

Malfunction of High Pressure Sensor315

Malfunction of Indoor Unit Fan Motor272

Malfunction of Inverter Radiating Fin Temperature Rise321

Malfunction of Inverter Radiating Fin Temperature Rise Sensor336

Malfunction of Liquid Pipe Thermistor 1 (R6T, R9T or R14T)312

Malfunction of Liquid Pipe Thermistor 2 (R7T or R15T)313

Malfunction of Low Pressure Sensor317

Malfunction of Moving Part of Electronic Expansion Valve (Y1E~ Y5E)297

Malfunction of Outdoor Unit Fan Motor294

Malfunction of Subcooling Heat Exchanger Gas Pipe Thermistor (R5T or R13T)314

Malfunction of Swing Flap Motor (M1S)274

Malfunction of System, Refrigerant System Address Undefined370

Malfunction of Temperature Sensor for Heat Exchanger Gas (R2T or R11T)309

Malfunction of Thermistor (R1T) for Outdoor Air306

Malfunction of Thermistor (R1T) for Suction Air284

Malfunction of Thermistor (R2T) for Heat Exchanger282

Malfunction of Thermistor (R3T) for Gas Pipes283

Malfunction of Thermistor (R4T or R12T) for Outdoor Unit Heat Exchanger311

Malfunction of Thermistor (R8T or R10T) for Suction Pipe310

Malfunction of Thermostat Sensor in Remote Control 285

Malfunction of Transmission between Centralized Controller and Indoor Unit366

Malfunction of Transmission between Indoor and Outdoor Units in the Same System358

Malfunction of Transmission between Indoor Units347

Malfunction of Transmission between Inverter and Control PC Board331

Malfunction of Transmission between Main and Sub Remote Controls 357

Malfunction of Transmission between Optional Controllers for Centralized Control 373

Malfunction of Transmission between Remote Control and Indoor Unit 350

Master Unit Central Connector Setting Table 389

Master-Slave Unit Setting Table 390

Method of Checking the Inverter's Power Transistors and Diode Modules 458

Momentary Overcurrent of Inverter Compressor 324, 326

Monitor Mode 228

Motor Side Connectors 383

O

Operating Priority and Rotation of Compressors 109

Operation Lamp Blinks 377

Operation Mode 106

Outdoor Unit Fan Control in Cooling Operation 117

Outdoor Unit PC Board Layout 201

Outline of Control 141

Overload / Overcurrent / Lock of Indoor Unit Fan Motor 273

P

PC Board Defect 267, 286, 372

Piping Diagrams Indoor Unit 403

Outdoor Unit 398

Piping Installation Point 448

The Example of A Wrong Pattern 449

Power Supply Insufficient or Instantaneous Failure 343

Power Transistor Check 385

Pressure Sensor 457

R

Refrigerant Circuit 58

BS Unit Functional Parts 68

Indoor Units 69

REMQ10P, 12P 65

REMQ14P, 16P 67

REMQ8P 63

REYQ14P, 16P 60

REYQ8P, 10P, 12P 58

Refrigerant Flow for Each Operation Mode 75

Operation of refrigerant regulator 99

Pressure Equalizing when Switching Operation Cooling / Heating 100

REYQ14P, 16P 83

REYQ8P, 10P, 12P 75

Refrigerant Overcharged 301

Remote Control Self-Diagnosis Function 259

Remote Control Service Mode 257

Reverse Phase, Open Phase 342

S

Self-diagnosis by Wired Remote Control 252

Self-diagnosis by Infrared Remote Control	253
Setting by Push Button Switches	221
Setting Mode 1	223
Setting Mode 2	224
Setting of Low Noise Operation and Demand	
Operation	231
Image of Operation in the Case of A	232, 234
Image of Operation in the Case of	
A and B	232, 234
Image of Operation in the Case of B	232, 234
Simplified Remote Control	204
BRC2A51, BRC2C51	204
STD Compressor Motor Overcurrent/Lock	293
STD Compressor Overload Protection	139
System is not Set yet	369

T

Test Operation	156
Thermostat Sensor in Remote Control	143
Cooling	143
Heating	144
Transmission Failure (Across Outdoor Units)	351
Troubleshooting	
(OP: Central Remote Control)	372
Troubleshooting	
(OP: Unified ON/OFF Controller)	377
Troubleshooting by Remote Control	251

V

Vacuuming and Dehydration Procedure	394
---	-----

W

Wired Remote Control	202
Infrared Remote Control - Indoor Unit	203
BRC4C type	203
BRC7C type	203
BRC7E type	203
Wiring Diagrams for Reference	410
Field Wiring	415
Indoor Unit	418
Outdoor Unit	410

In all of us,
a green heart



Daikin's unique position as a manufacturer of air conditioning equipment, compressors and refrigerants has led to its close involvement in environmental issues. For several years Daikin has had the intension to become a leader in the provision of products that have limited impact on the environment. This challenge demands the eco design and development of a wide range of products and an energy management system, resulting in energy conservation and a reduction of waste.



Daikin Europe N.V. is approved by LRQA for its Quality Management System in accordance with the ISO9001 standard. ISO9001 pertains to quality assurance regarding design, development, manufacturing as well as to services related to the product.



ISO14001 assures an effective environmental management system in order to help protect human health and the environment from the potential impact of our activities, products and services and to assist in maintaining and improving the quality of the environment.



Daikin units comply with the European regulations that guarantee the safety of the product.

The present publication is drawn up by way of information only and does not constitute an offer binding upon Daikin Europe N.V.. Daikin Europe N.V. has compiled the content of this publication to the best of its knowledge. No express or implied warranty is given for the completeness, accuracy, reliability or fitness for particular purpose of its content and the products and services presented therein. Specifications are subject to change without prior notice. Daikin Europe N.V. explicitly rejects any liability for any direct or indirect damage, in the broadest sense, arising from or related to the use and/or interpretation of this publication. All content is copyrighted by Daikin Europe N.V..



DAIKIN EUROPE N.V.
Naamloze Vennootschap
Zandvoordestraat 300
B-8400 Oostende - Belgium
www.daikin.eu
BTW: BE 0412 120 336
RPR Oostende

VRV products are not within the scope of the Eurovent certification programme.

