

# Service Manual

## Air Conditioner

**CS-XE9EKE CU-XE9EKE**  
**CS-XE12EKE CU-XE12EKE**



### **⚠ WARNING**

This service information is designed for experienced repair technicians only and is not designed for use by the general public. It does not contain warnings or cautions to advise non-technical individuals of potential dangers in attempting to service a product. Products powered by electricity should be serviced or repaired only by experienced professional technicians. Any attempt to service or repair the product or products dealt with in this service information by anyone else could result in serious injury or death.

### **⚠ PRECAUTION OF LOW TEMPERATURE**

In order to avoid frostbite, be assured of no refrigerant leakage during the installation or repairing of refrigeration circuit.



## TABLE OF CONTENTS

	PAGE		PAGE
<b>1 Safety Precautions</b> -----	<b>3</b>	9.2. Indicator -----	19
<b>2 Specifications</b> -----	<b>5</b>	9.3. Diagnosis-----	20
2.1. CS-XE9EKE CU-XE9EKE-----	5	9.4. Outdoor Unit-----	21
2.2. CS-XE12EKE CU-XE12EKE -----	7	<b>10 Installation Instruction</b> -----	<b>23</b>
<b>3 Features</b> -----	<b>9</b>	10.1. Select The Best Location -----	23
<b>4 Location of Controls and Components</b> -----	<b>10</b>	10.2. Indoor Unit -----	24
4.1. Indoor Unit-----	10	10.3. Outdoor Unit-----	28
4.2. Outdoor Unit -----	10	<b>11 Operation and Function</b> -----	<b>31</b>
4.3. Remote Control -----	10	11.1. Basic Function -----	31
<b>5 Dimensions</b> -----	<b>11</b>	11.2. Airflow Direction -----	31
5.1. Indoor Unit & Remote Control -----	11	11.3. Quiet operation (Cooling Mode/Cooling area of Dry Mode) -----	32
5.2. Outdoor Unit -----	12	11.4. Powerful Mode Operation-----	33
<b>6 Refrigeration Cycle Diagram</b> -----	<b>13</b>	11.5. ON Timer Control -----	34
<b>7 Block Diagram</b> -----	<b>14</b>	11.6. OFF Timer Control-----	34
<b>8 Wiring Connection Diagram</b> -----	<b>15</b>	11.7. Auto Restart Control-----	34
8.1. Indoor Unit-----	15	11.8. Remote Control Signal Receiving Sound -----	34
8.2. Outdoor Unit -----	16	11.9. Filter Cleaning Control-----	35
<b>9 Printed Circuit Board</b> -----	<b>17</b>	11.10. Ventilation Control -----	36
9.1. Indoor Unit-----	17		

<b>12 Protection Control</b> -----	<b>37</b>
12.1. Time Delay Safety Control-----	37
12.2. 30 Seconds Forced Operation-----	37
12.3. Total Running Current Control-----	37
12.4. IPM (Power transistor) Protection Control (DC Peak detection)-----	37
12.5. Compressor Overheating Prevention Control----	37
12.6. Outdoor High Pressure Prevention Control (Cooling and Dry operations)-----	37
12.7. Compressor Protection Control (Refrigeration Cycle Abnormality)-----	37
12.8. Four-way Valve Operation Detection Control (Switching Abnormality between Cooling and Heating)-----	38
12.9. Anti-Freezing Control (Cooling and Dry operations)-----	38
12.10. Outdoor Air Temperature Control-----	38
12.11. Indoor Intake Air Temperature Control (Heating operation)-----	38
<b>13 Servicing Mode</b> -----	<b>39</b>
13.1. Auto OFF/ON Button-----	39
13.2. Various Setting Mode-----	40
13.3. Individual Correspondence Mode-----	41
13.4. Select Remote Control Transmission Code-----	42
<b>14 Demo Mode</b> -----	<b>43</b>
<b>15 Troubleshooting Guide</b> -----	<b>44</b>
15.1. Refrigeration Cycle System-----	44
15.2. Relationship Between The Condition of The Air Conditioner and Pressure and Electric Current-----	45
15.3. Breakdown Self Diagnosis Function-----	46
15.4. Error Codes Table-----	47
15.5. Movable Front Panel Malfunction-----	48
15.6. Initial Operation After Installation-----	48
15.7. Error During Filter Cleaning Operation-----	48
15.8. Error During Ventilation Operation-----	48
<b>16 Disassembly and Assembly Instructions</b> -----	<b>49</b>
16.1. Indoor Electronic Controller, Auto Cleaning, Cross Flow Fan and Fan Motor Removal Procedures-----	49
16.2. Filter Cleaning Device Complete Removal Instructions-----	53
16.3. Ventilation Device Removal Instructions-----	55
16.4. Gear Removal Instructions-----	56
16.5. Outdoor Propeller Fan and Fan Motor-----	57
<b>17 Technical Data</b> -----	<b>59</b>
17.1. CS-XE9EKE CU-XE9EKE-----	59
17.2. CS-XE12EKE CU-XE12EKE-----	67
17.3. Sensible Capacity Chart-----	75
<b>18 Exploded View and Replacement Parts List</b> -----	<b>76</b>
18.1. Indoor Unit-----	76
18.2. Outdoor Unit-----	78

# 1 Safety Precautions





- Read the following “SAFETY PRECAUTIONS” carefully before perform any servicing.
- Electrical work must be installed or serviced by a licensed electrician. Be sure to use the correct rating of the power plug and main circuit for the model installed.
- The caution items stated here must be followed because these important contents are related to safety. The meaning of each indication used is as below. Incorrect installation or servicing due to ignoring of the instruction will cause harm or damage, and the seriousness is classified by the following indications.



 <b>WARNING</b>	This indication shows the possibility of causing death or serious injury.
 <b>CAUTION</b>	This indication shows the possibility of causing injury or damage to properties.

- The items to be followed are classified by the symbols:

	This symbol denotes item that is PROHIBITED from doing.
---	---

- Carry out test running to confirm that no abnormality occurs after the servicing. Then, explain to user the operation, care and maintenance as stated in instructions. Please remind the customer to keep the operating instructions for future reference.

 <b>WARNING</b>	
1. Engage dealer or specialist for installation and servicing. If installation or servicing done by the user is defective, it will cause water leakage, electrical shock or fire.	
2. Install according to this installation instruction strictly. If installation is defective, it will cause water leakage, electrical shock or fire.	
3. Use the attached accessories parts and specified parts for installation and servicing. Otherwise, it will cause the set to fall, water leakage, fire or electrical shock.	
4. Install at a strong and firm location which is able to withstand the set's weight. If the strength is not enough or installation is not properly done, the set will drop and cause injury.	
5. For electrical work, follow the local national wiring standard, regulation and the installation instruction. An independent circuit and single outlet must be used. If electrical circuit capacity is not enough or defect found in electrical work, it will cause electrical shock or fire.	
6. Use the specified cable and connect tightly for indoor/outdoor connection. Connect tightly and clamp the cable so that no external force will be acted on the terminal. If connection or fixing is not perfect, it will cause heat-up or fire at the connection.	
7. Wire routing must be properly arranged so that control board cover is fixed properly. If control board cover is not fixed perfectly, it will cause heat-up or fire at the connection point of terminal, fire or electrical shock.	
8. When connecting the piping, do not allow air or any substances other than the specified refrigerant to enter the refrigeration cycle. Otherwise, this may lower the capacity, cause abnormally high pressure in the refrigeration cycle, and possibly result in explosion and injury.	
9. Thickness of copper pipes used must be more than 0.8 mm. Never use copper pipes thinner than 0.8 mm.	
10. It is desirable that the amount of residual oil is less than 40 mg/10m.	
11. Do not modify the length of the power supply cord or use of the extension cord, and do not share the single outlet with other electrical appliances. Otherwise, it will cause fire or electrical shock.	



 <b>CAUTION</b>	
1. The equipment must be earthed. It may cause electrical shock if grounding is not perfect.	
2. Do not install the unit at place where leakage of flammable gas may occur. In case gas leaks and accumulates at surrounding of the unit, it may cause fire.	
3. Carry out drainage piping as mentioned in installation instructions. If drainage is not perfect, water may enter the room and damage the furniture.	
4. Pb free solder has a higher melting point than standard solder; typically the melting point is 50 - 70°F (30 - 40°C) higher. Please use a high temperature solder iron. In case of the soldering iron with temperature control, please set it to 700 ± 20°F (370 ± 10°C). Pb free solder will tend to splash when heated too high (about 1100°F / 600°C).	

**ATTENTION**

- |   |
|---|
| 1. Selection of the installation location. Select an installation location which is rigid and strong enough to support or hold the unit, and select a location for easy maintenance.  |
| 2. Power supply connection to the conditioner. Connect the power supply cord of the air conditioner to the mains using one of the following methods.<br>Power supply point shall be the place where there is ease for access for the power disconnection in case of emergency.<br>In some countries, permanent connection of this room air conditioner to the power supply is prohibited.<br>1. Power supply connection to the receptacle using a power plug. Use an approved power plug with earth pin for the connection to the socket.<br>2. Power supply connection to a circuit breaker for the permanent connection. Use an approved circuit breaker for the permanent connection. It must be a double pole switch with a minimum 3.5 mm contact gap. |
| 3. Do not release refrigerant during piping work for installation, servicing, reinstallation and during repairing a refrigeration parts. Take care of the liquid refrigerant, it may cause frostbite.   |
| 4. Installation work. It may need two people to carry out the installation work.  |
| 5. Do not install this appliance in a laundry room or other location where water may drip from the ceiling, etc.  |

## 2 Specifications

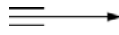
### 2.1. CS-XE9EKE CU-XE9EKE

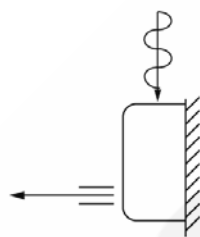
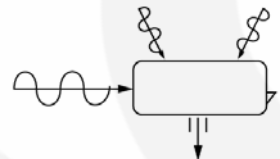
		Unit	CS-XE9EKE	CU-XE9EKE
Performance Test Condition			EUROVENT/AS	
Power Source	(Phase, Voltage, Cycle)	ø, V, Hz	Single, 230 - 240, 50	
Cooling Capacity		kW kcal/h	2.60 (0.60 - 3.00) 2,240 (520 - 2,580)	
Heating Capacity		kW kcal/h	3.60 (0.60 - 6.10) 3,100 (520 - 5,250)	
Moisture Removal		l/h (Pint/h)	1.6 (3.4)	
Airflow Method		<p>OUTLET</p>  <p>INTAKE</p> 	<p>SIDE VIEW</p> 	<p>TOP VIEW</p> 
Air Volume	Lo	m <sup>3</sup> /min (cfm)	Cooling; 7.3 (260) Heating; 7.7 (270)	—
	Me	m <sup>3</sup> /min (cfm)	Cooling; 8.9 (310) Heating; 9.5 (340)	—
	Hi	m <sup>3</sup> /min (cfm)	Cooling; 10.6 (370) Heating; 11.7 (410)	Cooling; 29.8 (1,050)
	SHi	m <sup>3</sup> /min (cfm)	Cooling; 11.3 (400) Heating; 12.1 (430)	—
Noise Level		dB (A)	Cooling; High 39 - 39, Low 26 - 26 Heating; High 40 - 40, Low 27 - 27	Cooling; High 46 - 46 Heating; High 47 - 47
		Power level dB	Cooling; High 50 - 50 Heating; High 51 - 51	Cooling; High 59 - 59 Heating; High 60 - 60
Electrical Data	Input Power	W	Cooling; 570 (120 - 700) Heating; 810 (115 - 1,640)	
	Running Current	A	Cooling; 2.8 - 2.7 Heating; 3.8 - 3.7	
	EER	W/W (kcal/hW)	Cooling; 4.56 (3.93)	
	COP	W/W (kcal/hW)	Heating; 4.44 (3.83)	
	Starting Current	A	3.8	
Piping Connection Port (Flare piping)		inch inch	G ; Half Union 3/8" L ; Half Union 1/4"	G ; 3-way valve 3/8" L ; 2-way valve 1/4"
Pipe Size (Flare piping)		inch inch	G ; (Gas side) 3/8" L ; (Liquid side) 1/4"	G ; (Gas side) 3/8" L ; (Liquid side) 1/4"
Drain Hose	Inner diameter	mm	16	
	Length	m	0.65	
Power Cord	Length	m	1.8	
	Number of core-wire		3 (1.5 mm <sup>2</sup> )	
Dimensions	Height	inch (mm)	12 (305)	
	Width	inch (mm)	34 - 1/4 (870)	
	Depth	inch (mm)	9 - 1/32 (229)	
Net Weight		lb (kg)	29 (13.0)                      82 (37)	
Compressor	Description		—	
	Motor Type		—	
	Rated Output	W	—                      750	

		Unit	CS-XE9EKE	CU-XE9EKE	
Air Circulation	Description		Cross-flow Fan	Propeller Fan	
	Material		ASG20K1	P.P	
	Motor Type		Transistor (8-poles)	Induction (8-poles)	
	Input	W	44.3	61.3	
	Rated Output	W	30	40	
	Fan Speed	Low (Cool/Heat)	rpm	800 / 850	—
		Medium (Cool/Heat)	rpm	980 / 1,050	—
High (Cool/Heat)		rpm	1,170 / 1,280	790/800	
SuperHigh (Cool/Heat)		rpm	1,250 / 1,340	—	
Heat Exchanger	Description		Evaporator	Condenser	
	Tube material		Copper	Copper	
	Fin material		Aluminium (Pre Coat)	Aluminium	
	Fin Type		Slit Fin	Corrugated Fin	
	Row / Stage		(Plate fin configuration, forced draft)		
			2 / 15	2 / 24	
	FPI		20	17	
Size (W × H × L)	mm	610 × 315 × 25.4	718.4 × 504 × 36.4 689.8		
Refrigerant Control Device			—	Exp. Valve	
Refrigerations Oil		(cm <sup>3</sup> )	—	RB68A (400)	
Refrigerant (R410A)		g (oz)	—	930 (32.8)	
Thermostat			Electronic Control	—	
Protection Device			—	Electronic Control	
Capillary Tube	Length	mm	—	—	
	Flow Rate	l/min	—	—	
	Inner Diameter	mm	—	—	
Air Filter	Material		PET	—	
	Style				
Compressor Capacitor		μF, VAC	—	—	
Fan Motor Capacitor		μF, VAC	—	—	

**Note:**

- Specifications are subject to change without notice for further improvement.

## 2.2. CS-XE12EKE CU-XE12EKE

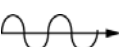
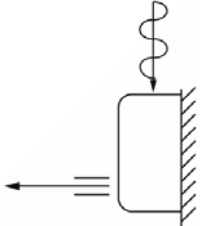
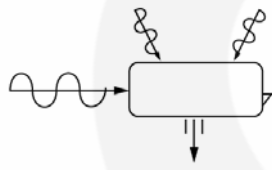
		Unit	CS-XE12EKE	CU-XE12EKE	
Performance Test Condition			EUROVENT/AS		
Power Source (Phase, Voltage, Cycle)		ø, V, Hz	Single, 230 - 240, 50		
Cooling Capacity		kW	3.50 (0.60 - 4.00)		
		kcal/h	3,010 (520 - 3,440)		
Heating Capacity		kW	4.80 (0.60 - 6.70)		
		kcal/h	4,130 (520 - 5,760)		
Moisture Removal		l/h (Pint/h)	2.0 (4.2)		
Airflow Method		OUTLET   INTAKE 	SIDE VIEW 	TOP VIEW 	
Air Volume	Lo	m <sup>3</sup> /min (cfm)	Cooling; 8.2 (290) Heating; 9.2 (320)	—	
	Me	m <sup>3</sup> /min (cfm)	Cooling; 10.1 (360) Heating; 10.8 (380)	—	
	Hi	m <sup>3</sup> /min (cfm)	Cooling; 11.9 (420) Heating; 12.7 (450)	Cooling; 31.0 (1,090)	
	SHi	m <sup>3</sup> /min (cfm)	Cooling; 12.6 (450) Heating; 13.2 (470)	—	
Noise Level		dB (A)	Cooling; High 42 - 42, Low 29 - 29 Heating; High 42 - 42, Low 33 - 33	Cooling; High 48 - 48 Heating; High 50 - 50	
		Power level dB	Cooling; High 53 - 53 Heating; High 53 - 53	Cooling; High 61 - 61 Heating; High 63 - 63	
Electrical Data	Input Power	W	Cooling; 880 (120 - 1,100) Heating; 1,220 (115 - 1,840)		
	Running Current	A	Cooling; 4.1 - 4.0 Heating; 5.6 - 5.4		
	EER	W/W (kcal/hW)	Cooling; 3.98 (3.42)		
	COP	W/W (kcal/hW)	Heating; 3.93 (3.39)		
	Starting Current	A	5.6		
Piping Connection Port (Flare piping)		inch	G ; Half Union 1/2"	G ; 3-way valve 1/2"	
		inch	L ; Half Union 1/4"	L ; 2-way valve 1/4"	
Pipe Size (Flare piping)		inch	G ; (Gas side) 1/2"	G ; (Gas side) 1/2"	
		inch	L ; (Liquid side) 1/4"	L ; (Liquid side) 1/4"	
Drain Hose	Inner diameter	mm	16		
	Length	m	0.65		
Power Cord	Length	m	1.8		
	Number of core-wire		3 (1.5 mm <sup>2</sup> )		
Dimensions	Height	inch (mm)	12 (305)		
	Width	inch (mm)	34 - 1/4 (870)		
	Depth	inch (mm)	9 - 1/32 (229)		
Net Weight		lb (kg)	29 (13.0)		
Compressor	Description		—		
	Motor Type		—		
	Rated Output	W	—		
Air Circulation	Description		Cross-flow Fan	Propeller Fan	
	Material		ASG20K1	P,P	
	Motor Type		Transistor (8-poles)	Induction (8-poles)	
	Input	W	44.3		
	Rated Output	W	30		
	Fan Speed	Low (Cool/Heat)	rpm	900 / 1,000	
		Medium (Cool/Heat)	rpm	1,100 / 1,180	
High (Cool/Heat)		rpm	1,300 / 1,380		
SuperHigh (Cool/Heat)		rpm	1,380 / 1,440		

		Unit	CS-XE12EKE	CU-XE12EKE
Heat Exchanger	Description		Evaporator	Condenser
	Tube material		Copper	Copper
	Fin material		Aluminium (Pre Coat)	Aluminium
	Fin Type		Slit Fin	Corrugated Fin
	Row / Stage		(Plate fin configuration, forced draft)	
	FPI		20	17
	Size (W × H × L)	mm	610 × 315 × 25.4	718.4 × 504 × 36.4 689.8
Refrigerant Control Device			—	Exp. Valve
Refrigerations Oil		(cm <sup>3</sup> )	—	RB68A (400)
Refrigerant (R410A)		g (oz)	—	970 (34.2)
Thermostat			Electronic Control	—
Protection Device			—	Electronic Control
Capillary Tube	Length	mm	—	—
	Flow Rate	l/min	—	—
	Inner Diameter	mm	—	—
Air Filter	Material		PET	—
	Style			—
Compressor Capacitor		μF, VAC	—	—
Fan Motor Capacitor		μF, VAC	—	—

**Note:**

- Specifications are subject to change without notice for further improvement.



## 3 Features

- **High Efficiency**
- **Compact Design**
- **Wider range of horizontal discharge air**
- **Long Installation Piping**
  - up to 15 meter for XE9EK & XE12EK
- **SUPER alleru buster**
  - Inactivate various harmful airborne elements including allergens, viruses and bacteria
- **Operation Improvement**
  - Quiet mode to provide quiet operation
  - Powerful mode to reach the desired room temperature quickly
  - 24-hour timer setting
  - Ventilation mode is to ventilate the dirty air of the room to outdoor, to keep the room fresh and clean
  - Random Auto Restart after power failure for safety restart operation
- **Serviceability Improvement**
  - Removable and washable front panel
  - Breakdown Self Diagnosis function
- **Filter Cleaning Control**
  - Cleans the filter automatically, to keep optimum performance under clean and comfortable environment.
  - This built-in cleaning mechanism cleans the filter automatically and minimizes filter clogging
  - It maintains the original performance of the air conditioner, while eliminates the unpleasant job of manual filter cleaning
- **Environmental Protection**
  - Non-ozone depletion substances refrigerant (R410A).

# 4 Location of Controls and Components

**Note:**

\* Movable front panel will open slightly for air intake purposes once the air conditioner operation starts. Movable front panel will remain open during air conditioner operation. It will close automatically once the air conditioner operation stops. In such a condition, do not interrupt the movable front panel movement as this may cause malfunction or unit breakdown. The above condition does not apply for filter cleaning.

## 4.3. Remote Control

### 4.1. Indoor Unit

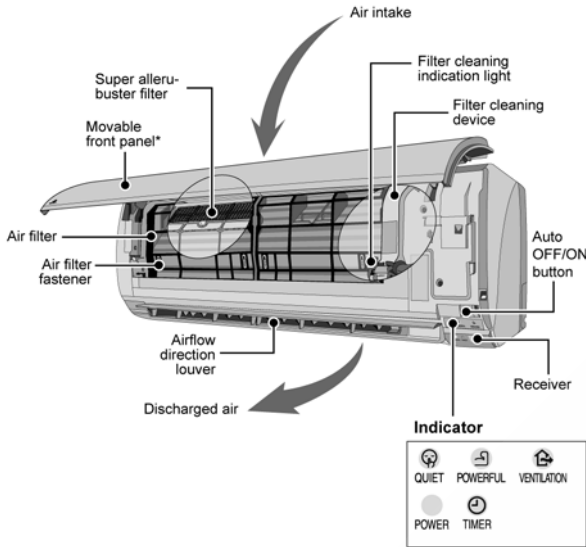

### 4.2. Outdoor Unit

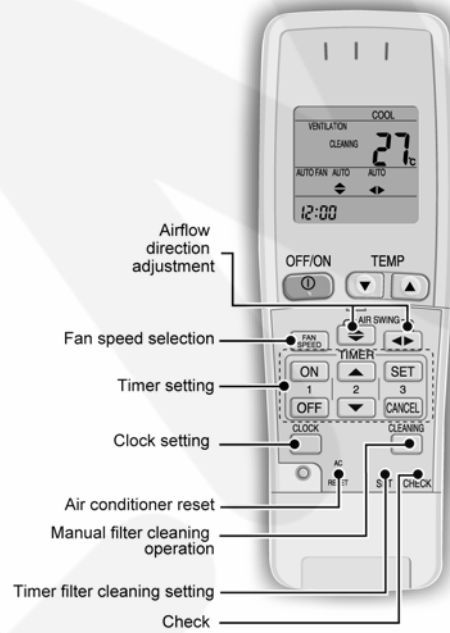
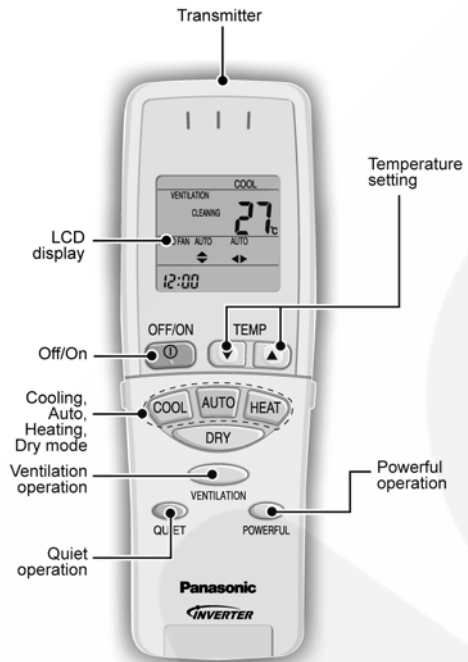
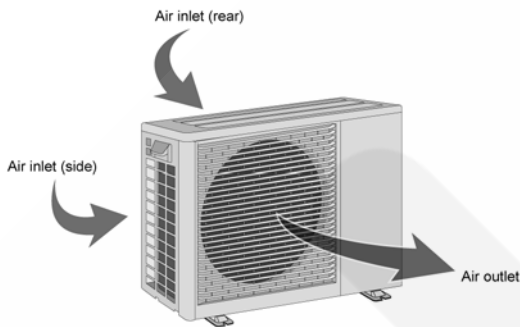

\* For normal operation, the and buttons are not in use.

# 5 Dimensions

## 5.1. Indoor Unit & Remote Control

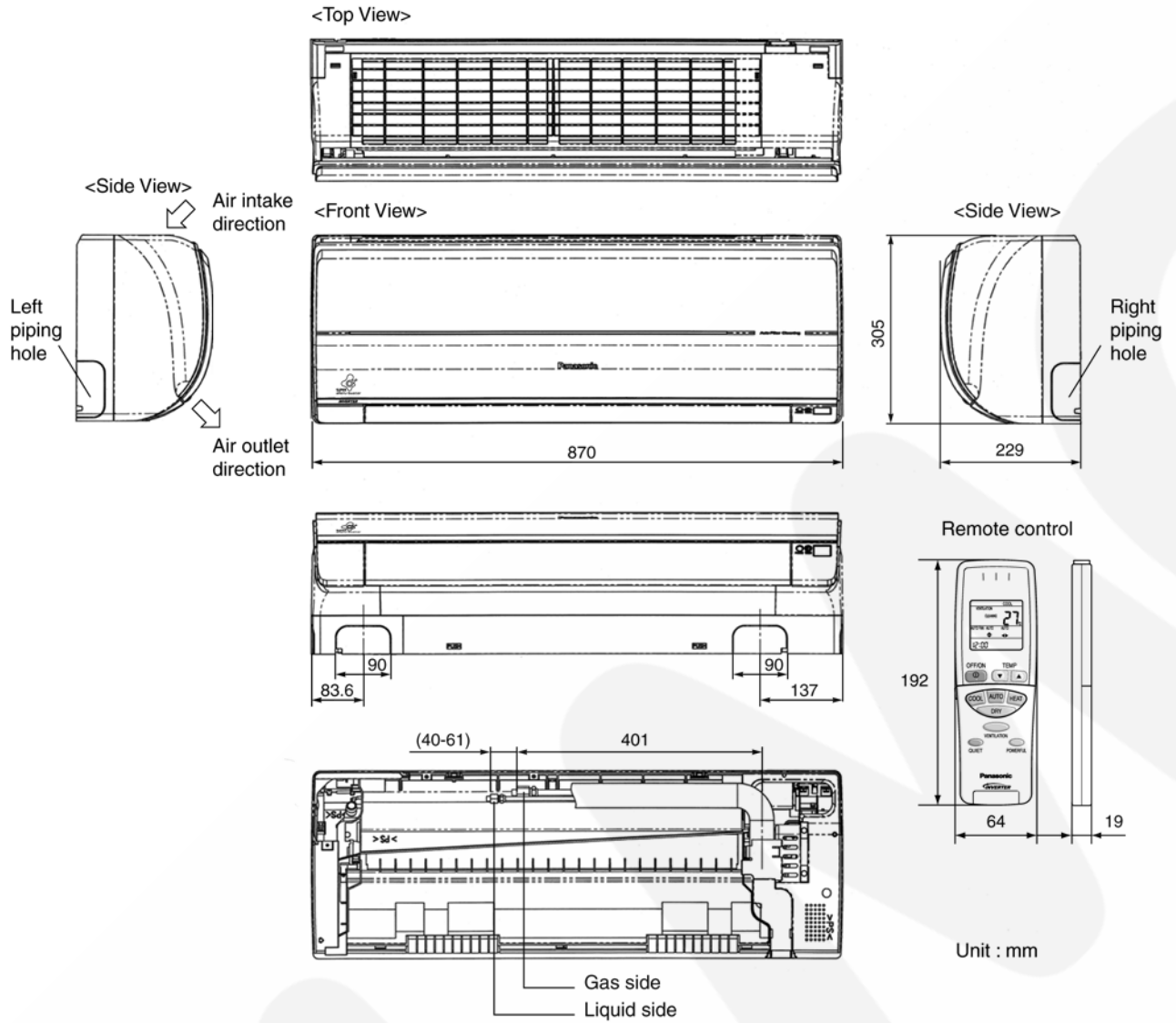

Relative position between the indoor unit and the installation plate

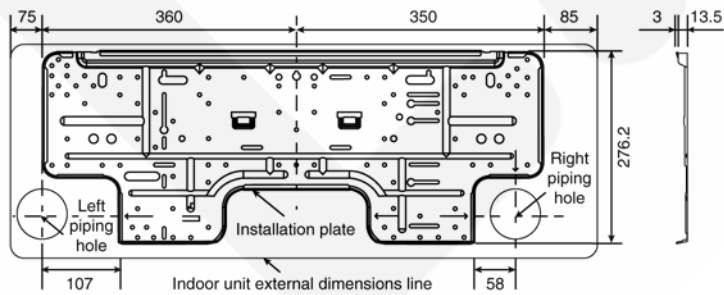

## 5.2. Outdoor Unit

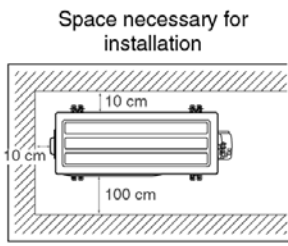

Anchor Bolt Pitch  
320 x 570

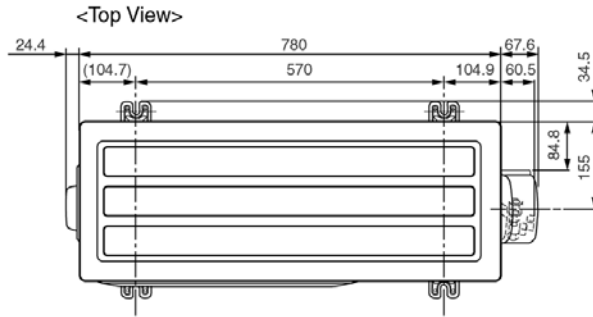

2-way valve at Liquid side  
(High Pressure)

3-way valve at Gas side  
(Low Pressure)

<Side View>

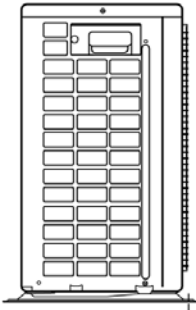

<Front View>

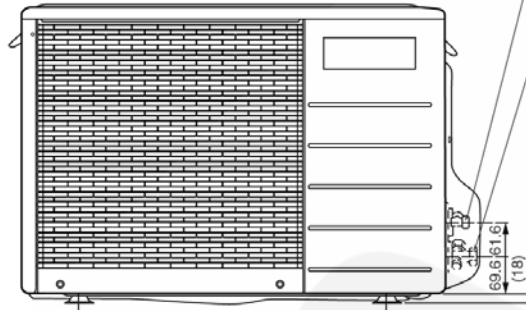

<Side View>

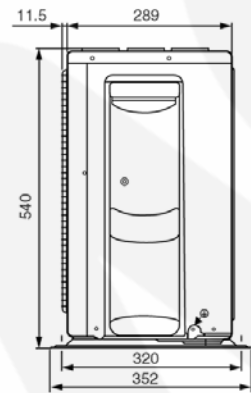

Unit : mm

# 6 Refrigeration Cycle Diagram

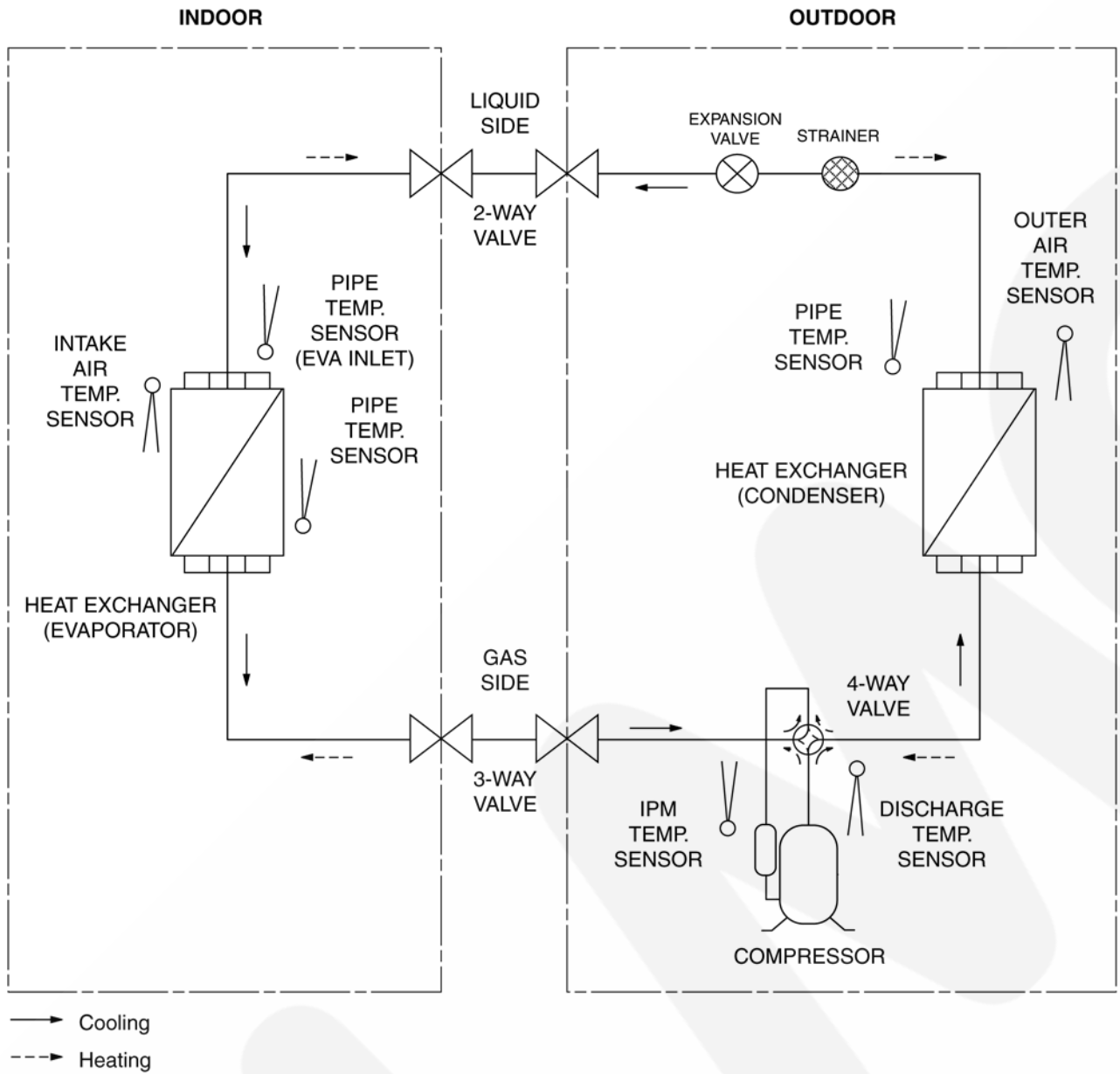

# 7 Block Diagram

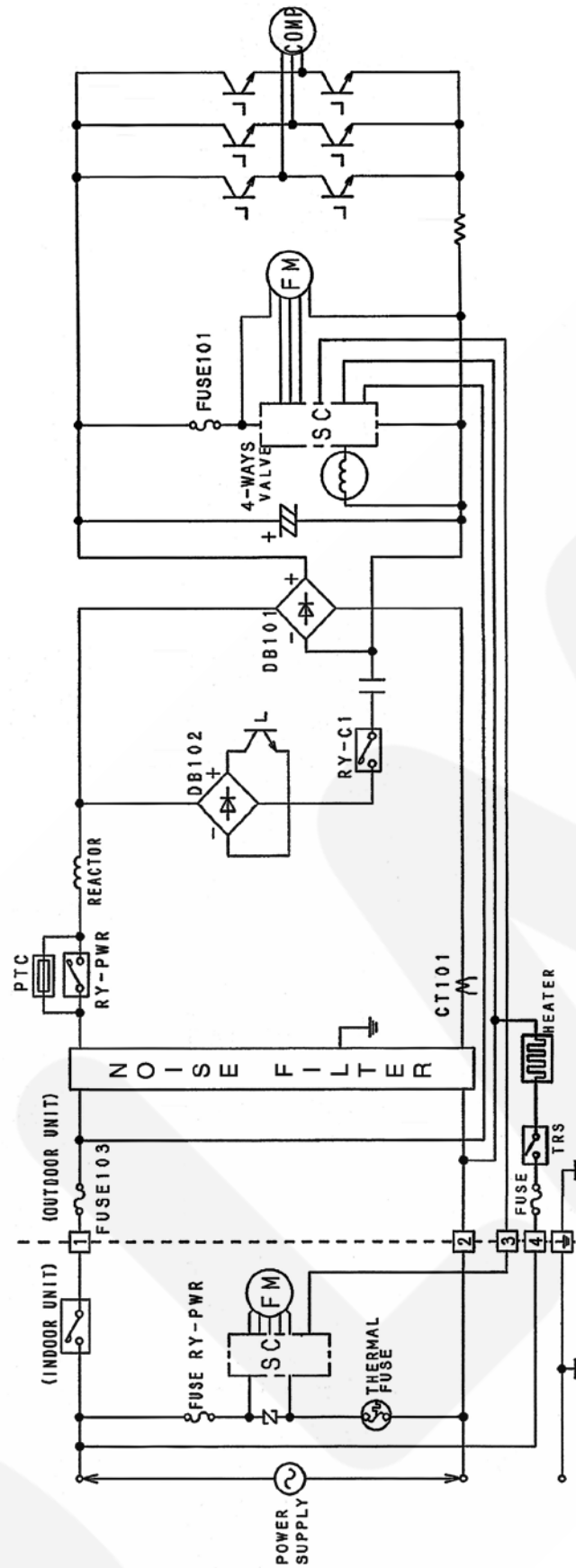



## 8.2. Outdoor Unit

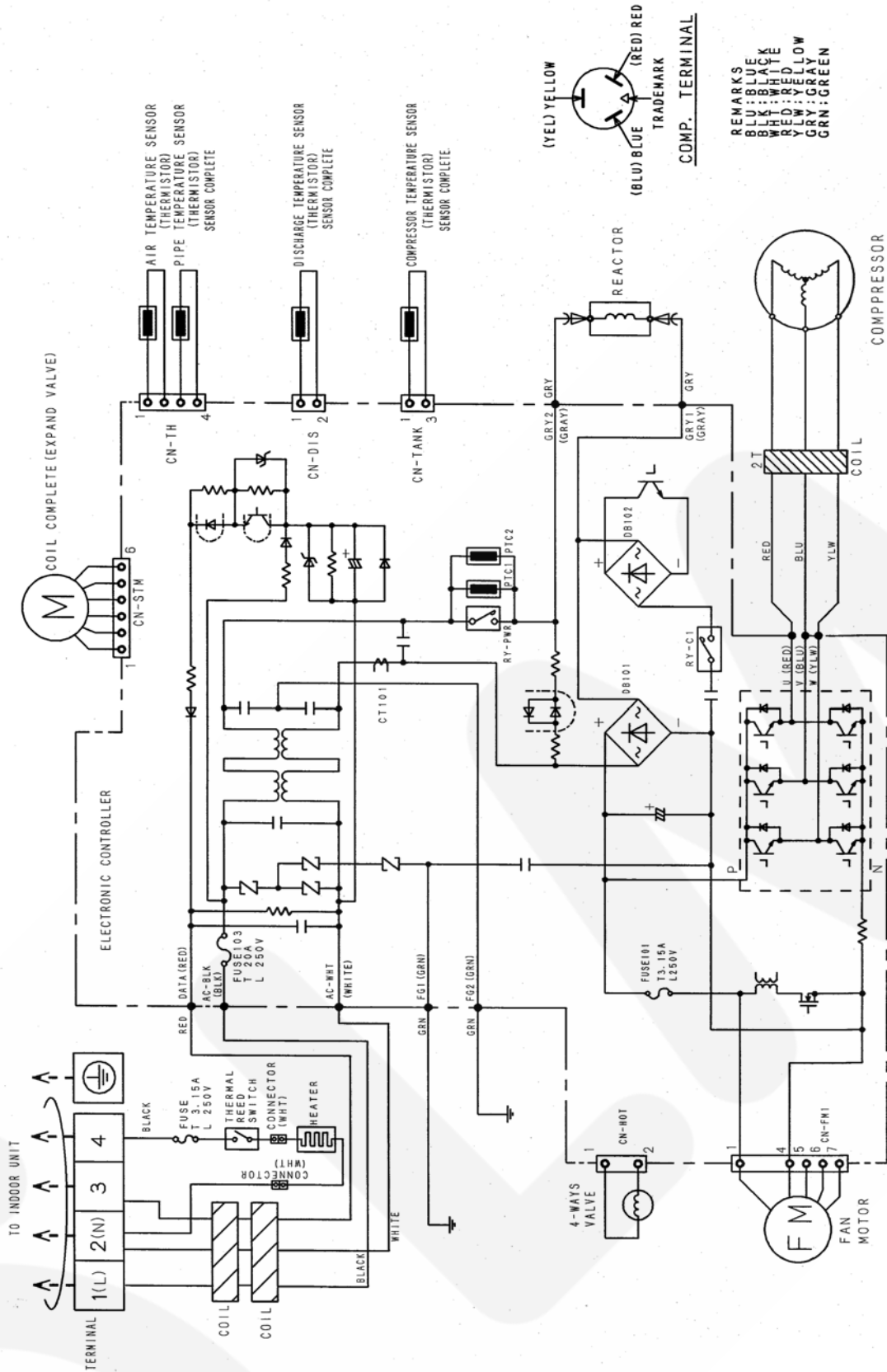



# 9 Printed Circuit Board

## 9.1. Indoor Unit

TOP VIEW

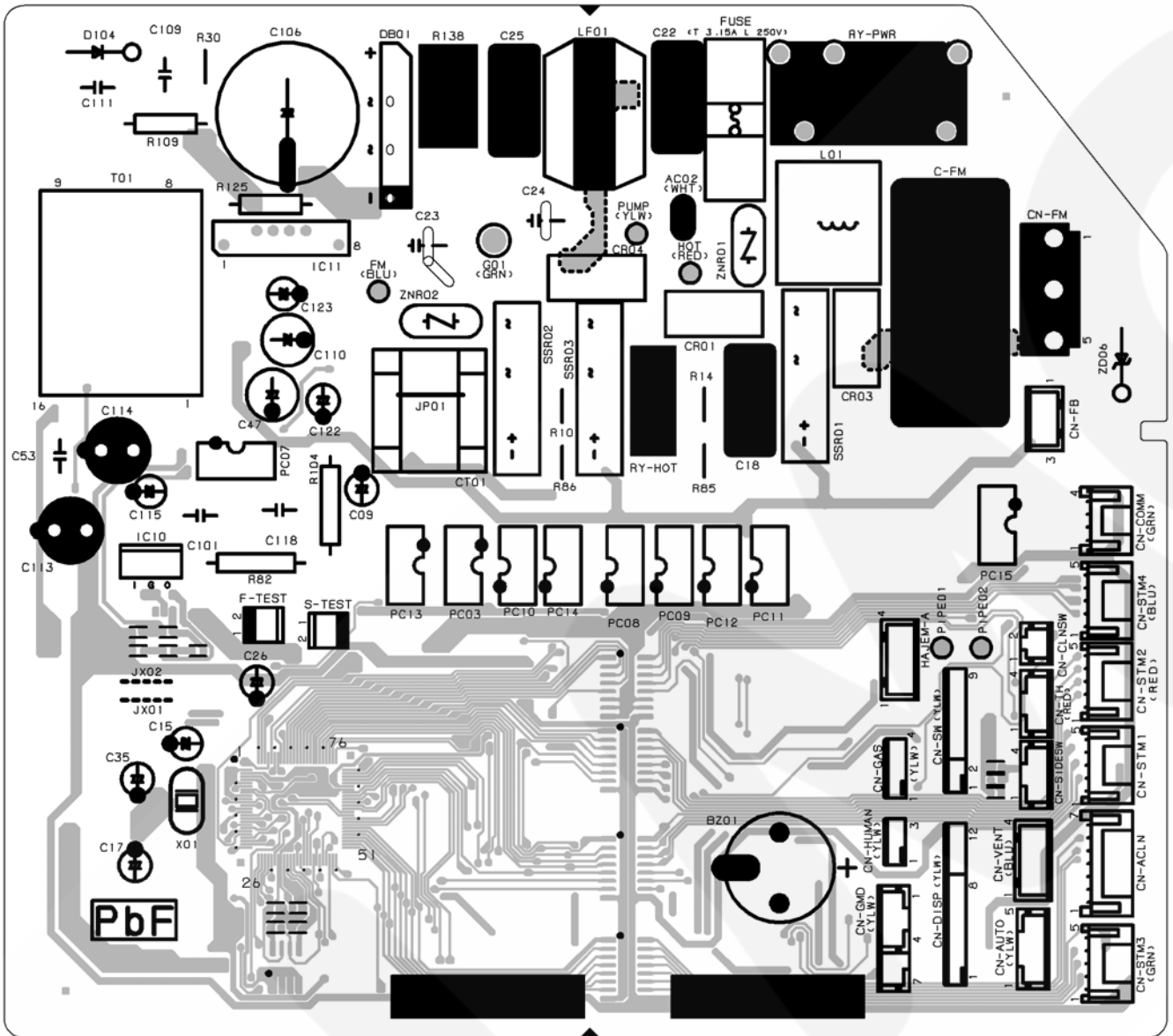

BOTTOM VIEW

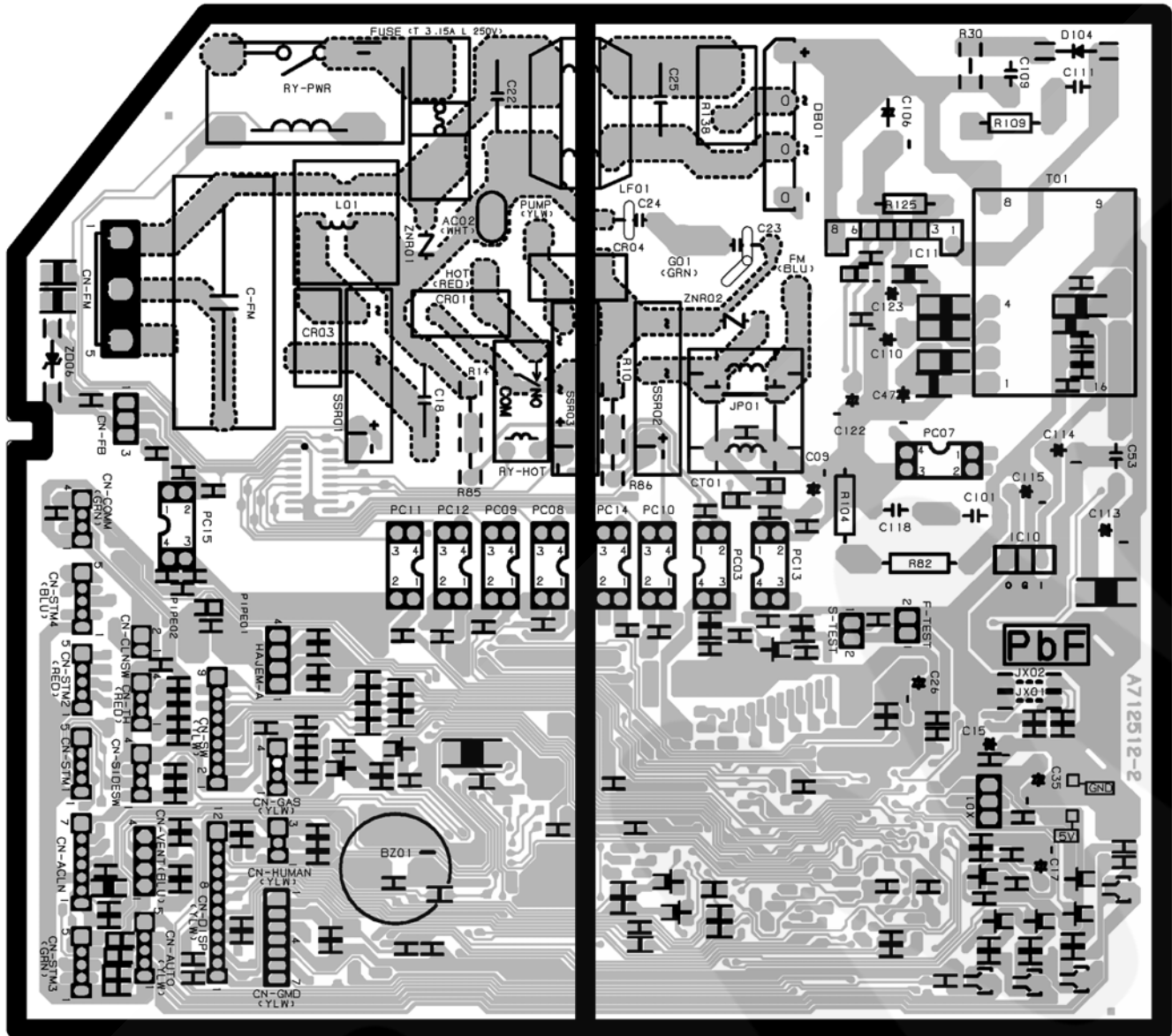

## 9.2. Indicator

### TOP VIEW

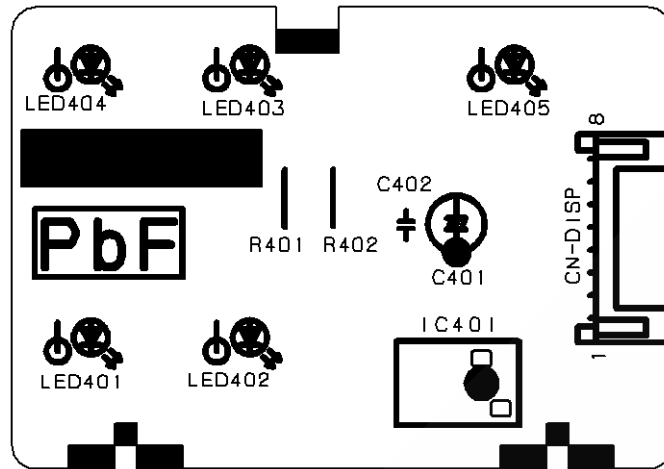

### BOTTOM VIEW

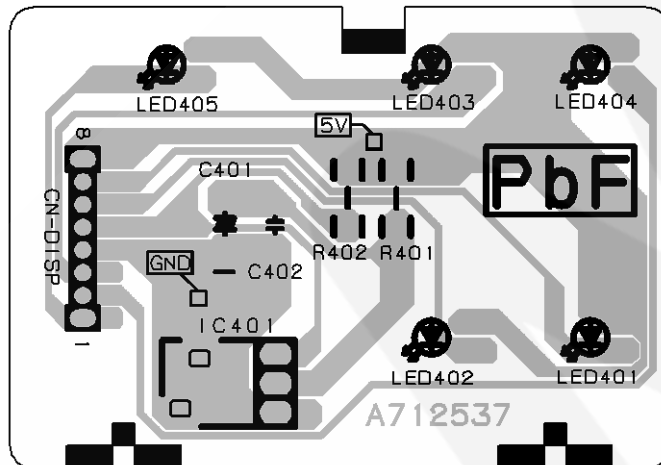

### 9.3. Diagnosis

TOP VIEW

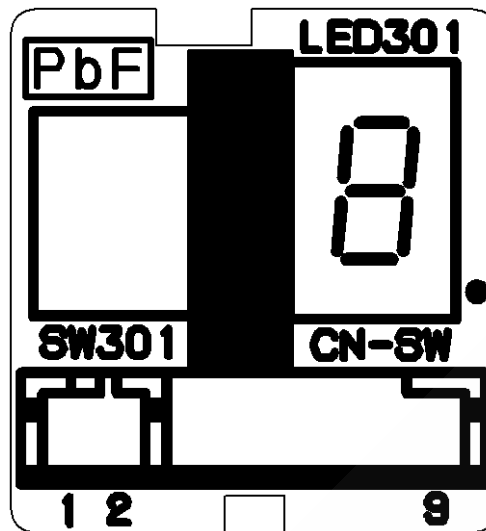

BOTTOM VIEW

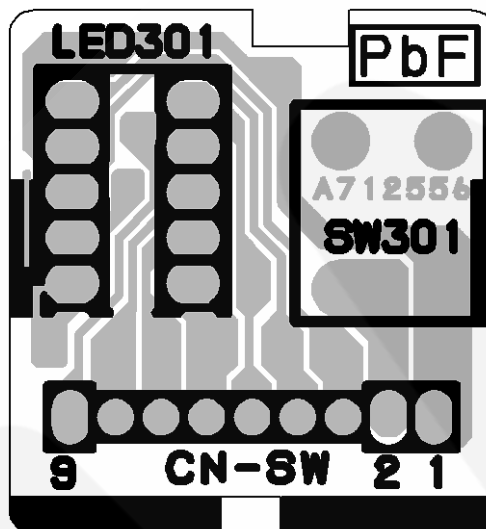

## 9.4. Outdoor Unit

TOP VIEW

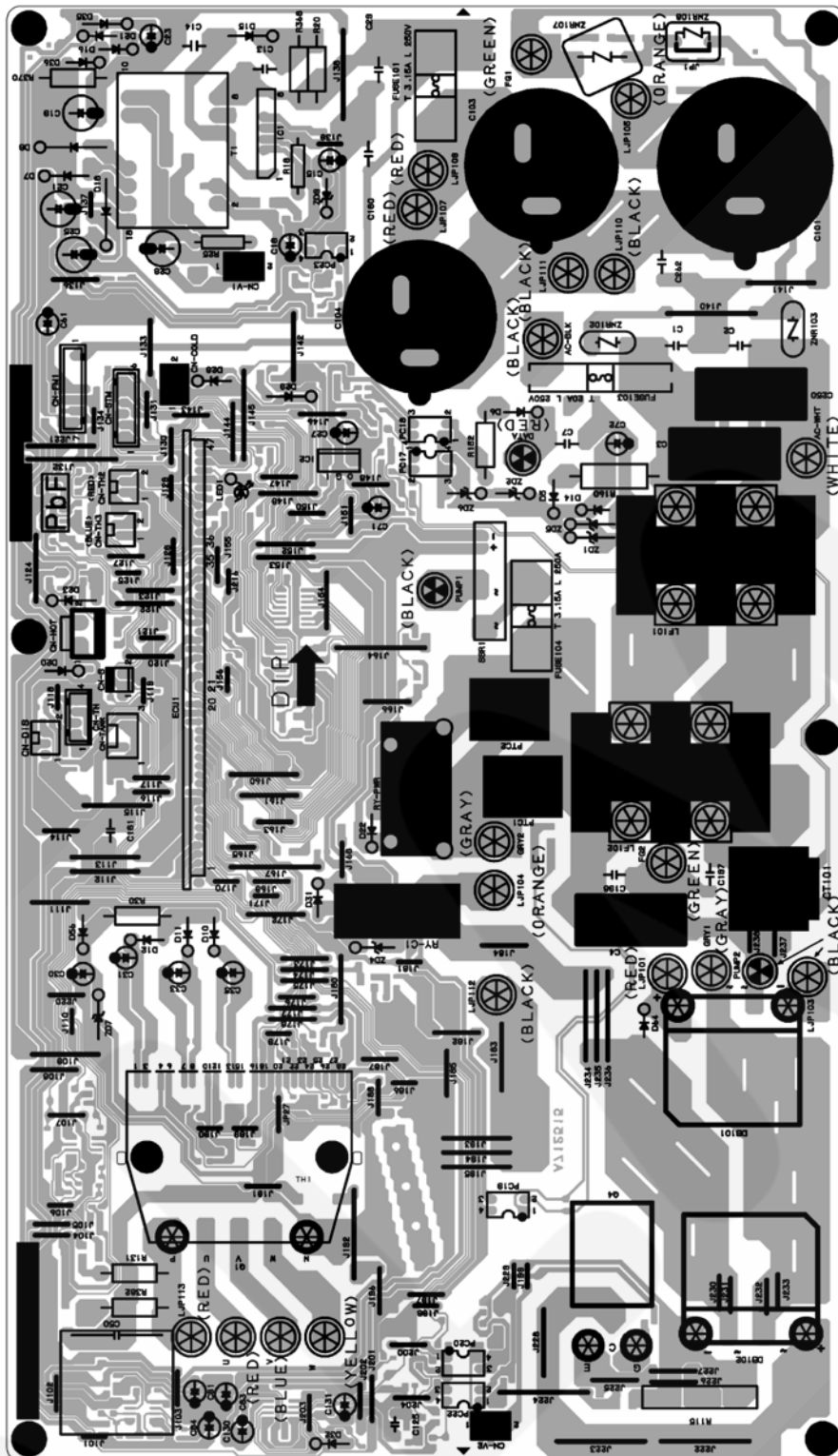

BOTTOM VIEW

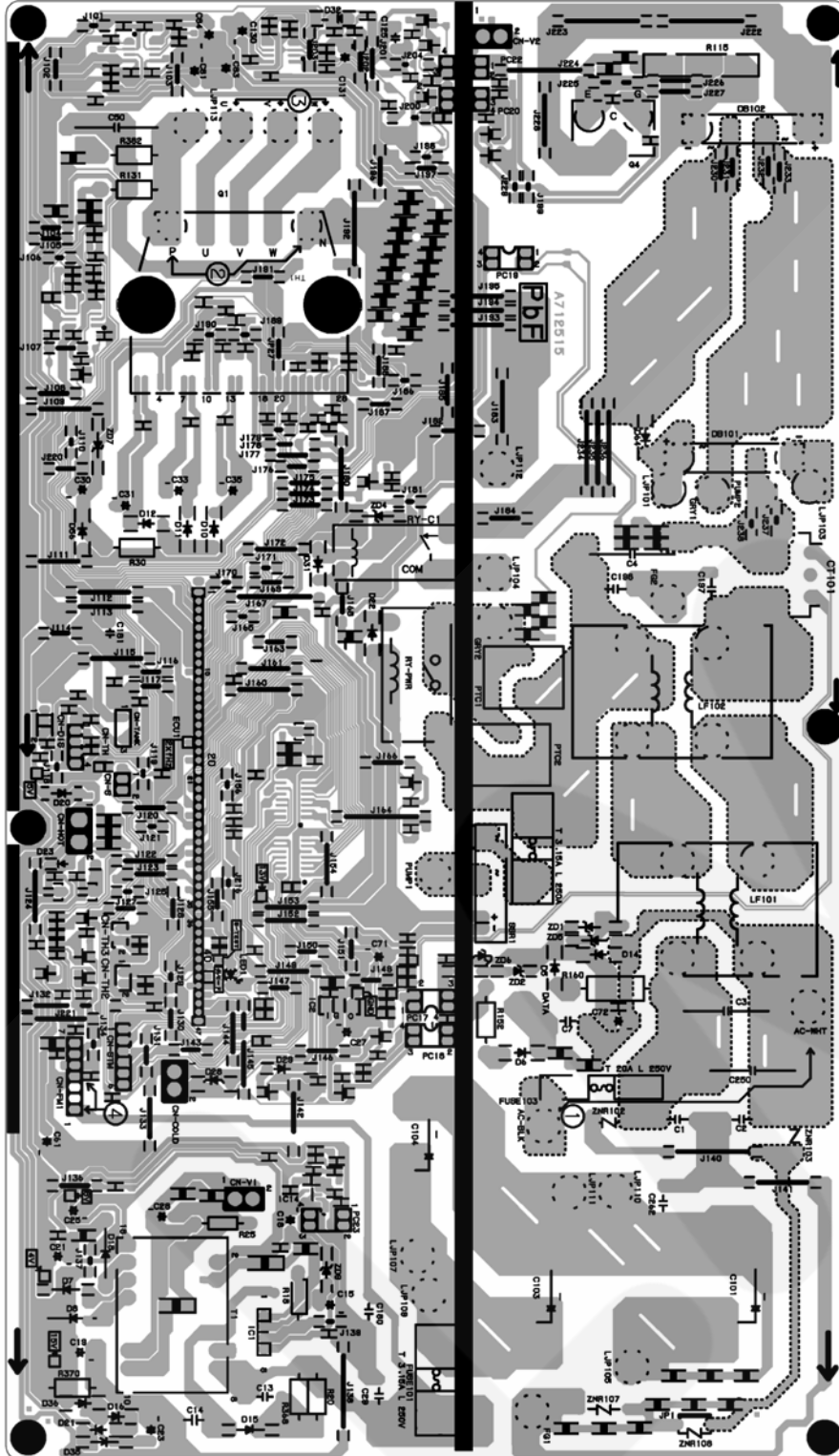

# 10 Installation Instruction

## 10.1. Select The Best Location

### Indoor Unit

- There should not be any heat source or steam near the unit.
- There should not be any obstacles blocking the air circulation.
- A place where air circulation in the room is good.
- A place where drainage can be easily done.
- A place where noise prevention is taken into consideration.
- Do not install the unit near the door way.
- Ensure the spaces indicated by arrows from the wall, ceiling, fence or other obstacles.
- Recommended installation height for indoor unit shall be at least 2.5 m.

### Outdoor Unit

- If an awning is built over the unit to prevent direct sunlight or rain, be careful that heat radiation from the condenser is not obstructed.
- There should not be any animal or plant which could be affected by hot air discharged.
- Keep the spaces indicated by arrows from wall, ceiling, fence or other obstacles.
- Do not place any obstacles which may cause a short circuit of the discharged air.
- If piping length is over the rated length, additional refrigerant should be added as shown in the table.

Model	Piping size		Rated Length (m)	Max Elevation (m)	Max. Piping Length (m)	Additional Refrigerant (g/m)
	Gas	Liquid				
XE9EKE	3/8"	1/4"	7.5	5	15	20
XE12EKE	1/2"	1/4"	7.5	5	15	20

### Indoor/Outdoor Unit Installation Diagram

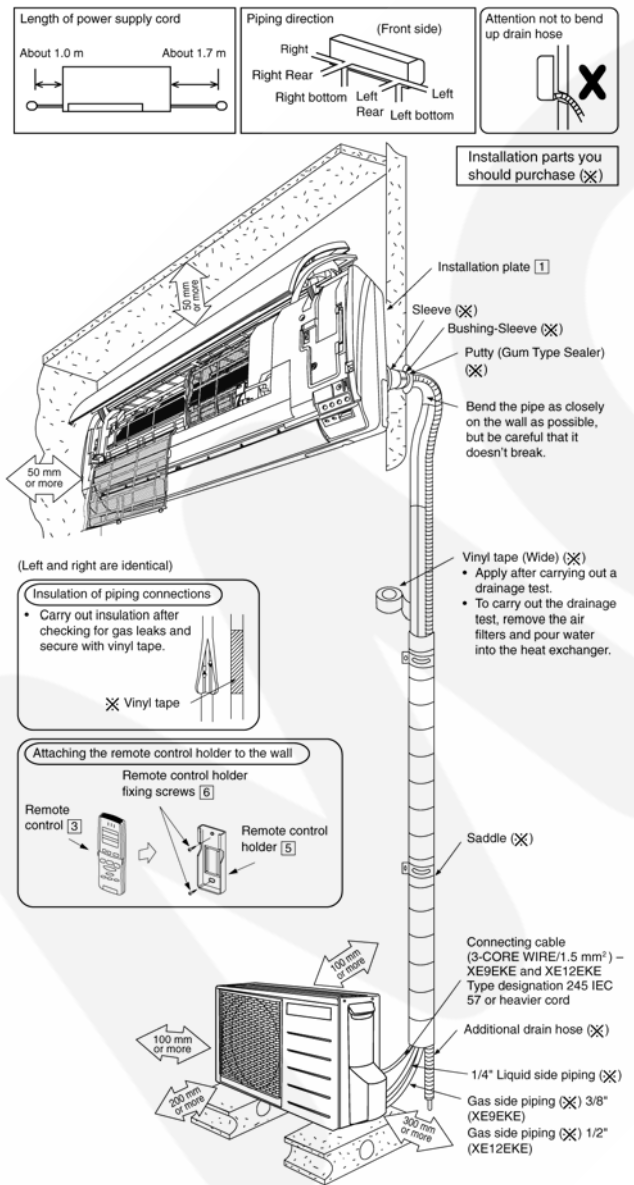

- This illustration is for explanation purposes only. The indoor unit will actually face a different way.

## 10.2. Indoor Unit

### 10.2.1. How To Fix Installation Plate

The mounting wall is strong and solid enough to prevent it from the vibration.

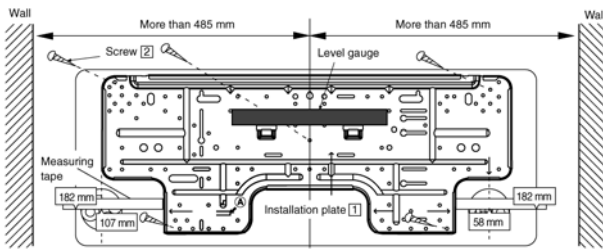

The centre of installation plate should be at more than 485 mm at right and left of the wall.

The distance from installation plate edge to ceiling should more than 75mm.

From installation plate left edge to unit's left side is 75 mm.

From installation plate right edge to unit's right is 85 mm.





- (A) : For left side piping, piping connection for liquid should be about 5 mm from this line.
- : For left side piping, piping connection for gas should be about 55 mm from this line.
- : For left side piping, piping connection cable should be about 750 mm from this line.

1. Mount the installation plate on the wall with 5 screws or more.  
(If mounting the unit on the concrete wall, consider using anchor bolts.)
  - Always mount the installation plate horizontally by aligning the marking-off line with the thread and using a level gauge.

### 10.2.3. Installing The Ventilation Hose

Carry out work carefully not to scratch the surface of the mobile panel.

#### Attached accessories

Accessories part/Qty.				
	9 Ventilation Hose (1) (ø23 : L2m)	10 Ventilation hose joint (1)	11 Top cover (1)	12 Fixing screw (short) (10 mm) (1)
Remarks	Decide the hose length and then cut it.	Use it with the top cover 11.	Attach at tip of ventilation hose 9 after installing the indoor Unit.	• Use it to fix the ventilation hose 9.

#### Ventilation hose connection diagram

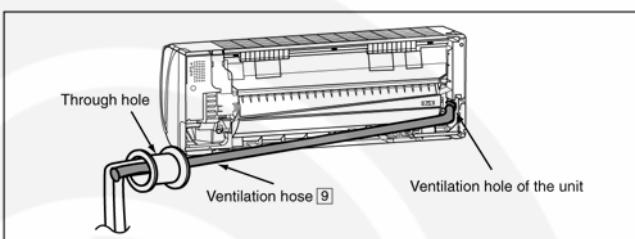

2. Drill the piping plate hole with ø70 mm hole-core drill.
  - Line according to the left and right side edge of the installation plate. The meeting point of the extended line is the centre of the hole. Another method is by putting measuring tape at position as shown in the diagram above. The hole centre is obtained by measuring the distance namely 107 mm and 58 mm for left and right edge of the installation plate respectively.
  - Drill the piping hole at either the right or the left and the hole should be slightly slanted to the outdoor side.

### 10.2.2. To Drill A Hole In The Wall And Install A Sleeve Of Piping

1. Insert the piping sleeve to the hole.
2. Cut the sleeve until it extrudes about 15 mm from the wall.

#### Caution

When the wall is hollow, please be sure to use the sleeve for tube ass'y to prevent dangers caused by mice biting the connecting cable.

3. Fix the bushing to the sleeve.
4. Finish by sealing the sleeve with putty or caulking compound at the final stage.

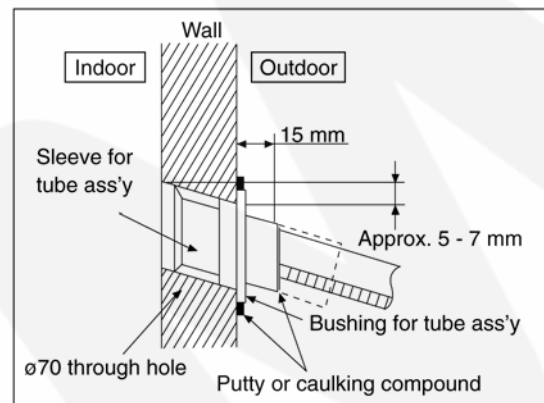

#### WARNING

- Attach the top cover 11 on the tip of the ventilation hose after installing the indoor unit.
- When using the optional extension ventilation hose: CZ-HV3P (ø23 : 3 m), make sure to attach the provided ventilation hose 9 to the main unit.
- Keep the ventilation hose as short as possible to prevent performance deterioration.



When using the extension ventilation hose (optional)

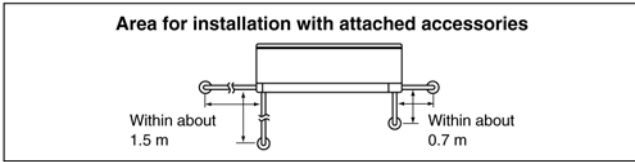
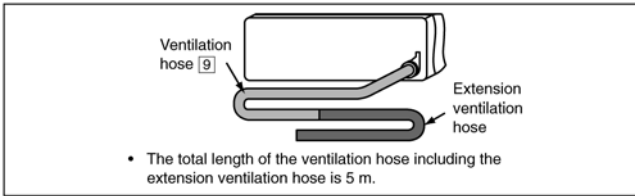

1. Removing the bottom left corner

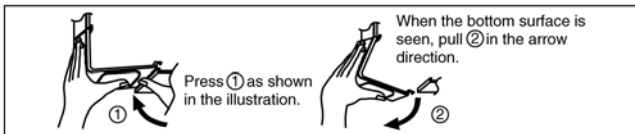

2. Connecting and fixing the ventilation hose to the ventilation hole of the unit

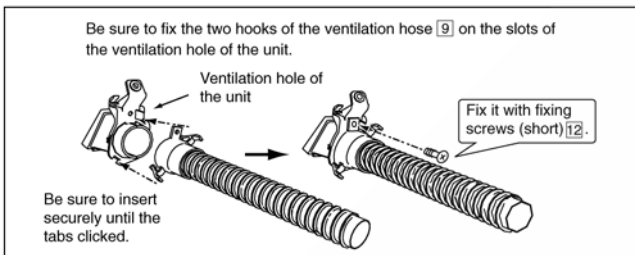

3. Keep the ventilation hose behind the chassis of the unit (in case installing in the rear right, right and bottom right)

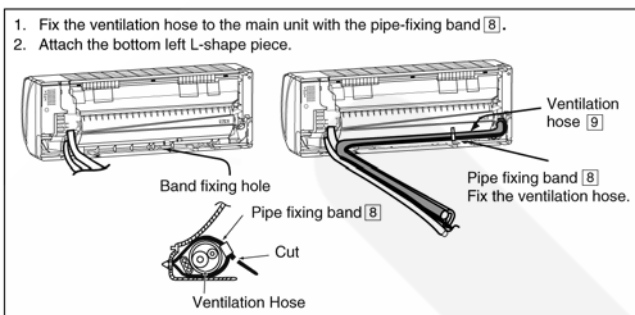

## 10.2.4. Indoor Unit Installation

### For the right rear piping

1. Pull out the Indoor piping
2. Install the Indoor Unit
3. Secure the Indoor Unit
4. Insert the connecting cable
5. Install the end of ventilation hose

### For the right and right bottom piping

1. Pull out the Indoor piping
2. Install the Indoor Unit
3. Insert the connecting cable
4. Secure the Indoor Unit
5. Install the end of ventilation hose

## For the embedded piping

### 1. Replace the drain hose

### 2. Bend the embedded piping

- Use a spring bender or equivalent to bend the piping so that the piping is not crushed.

### 3. Install the Indoor Unit

### 4. Cut and flare the embedded piping

- When determining the dimensions of the piping, slide the unit all the way to the left on the installation plate.
- Refer to the section "Cutting and flaring the piping"

### 5. Pull the connecting cable into indoor unit

- The inside and outside connecting cable can be connected without removing the front grille.

### 6. Connect the piping

- Please refer to "Connecting the piping" column in outdoor unit section. (Below steps are done after connecting the outdoor piping and gas-leakage confirmation.)

### 7. Insulate and finish the piping

- Please refer to "Piping and finishing" column of outdoor section and "Insulation of piping connections" column as mentioned in Indoor/Outdoor unit installation.

### 8. Secure the Indoor Unit

### 9. Install the end of ventilation hose

#### 1. Pull out the piping and drain hose

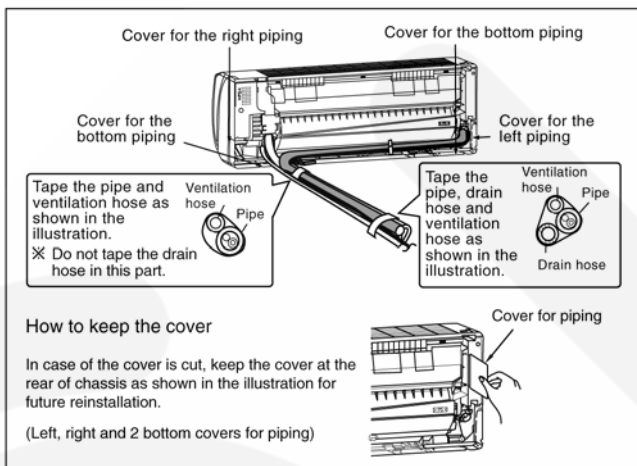

## 2. Install the Indoor Unit

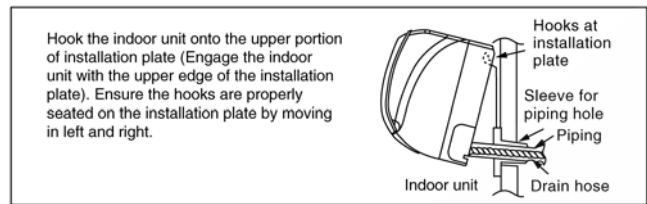

## 3. Secure the Indoor Unit

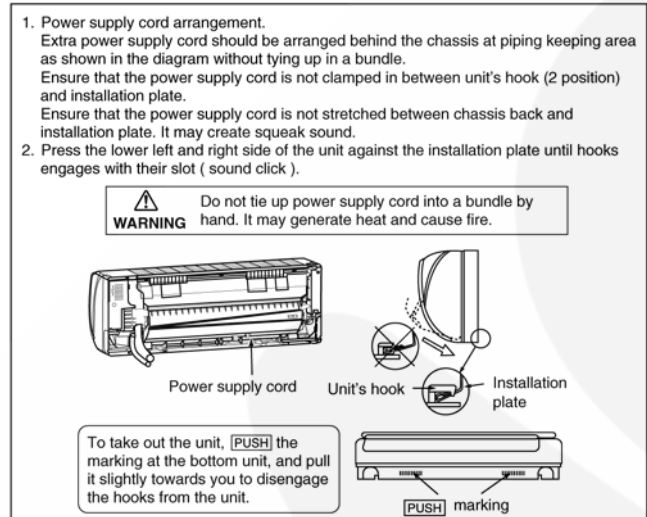

## 4. Insert the connecting cable

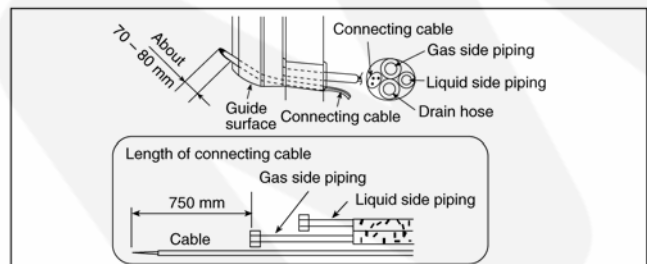

## 5. Treating methods of the end of the ventilation hose

1. Cut the end of the ventilation hose until it extrudes 40 mm from the through hole. Attach the ventilation hose joint 10 screwing into the piping pipe until it touches the end of the hose.
2. Keep the apertural area of the top cover 11 facing downward, fix the two hooks on the ventilation hose joint 10 to fix it at the horizontal position.

40 mm  
Ventilation hose 9  
Drain hose  
Pipe  
Ventilation hose joint 10  
Insert screwing into the pipe for piping plate hole

Be sure to fix the two hooks of the end cover on the ventilation hose joint.

Be sure to fix the top cover at the horizontal position using a level.

Top cover 11  
Apply putty

Keep the apertural area of the top cover facing downward.

When fixing the top cover 11 on the wall surface away from the piping plate hole, cut off the screw hole rib, and fix it with a screw (commercial item) as shown in the illustration below.

Wall surface side  
Screw hole rib  
Cut

**Once the installation work is completed, be sure to check the operation of the filter cleaning (one cycle).**  
Refer to the section "How to check the operation of the filter cleaning".

(This can be used for left rear piping & left bottom piping also.)

Exchange the drain hose and the cap

Rear view for left piping installation

Drain cap  
Drain hose

Connecting cable  
Drain hose

Adjust the piping slightly downwards.

Sleeve for piping hole  
Drain hose  
Piping  
Connecting cable  
More than approx. 950 mm

In case a hole can be drilled in the exterior wall for the embedded piping.

- -Drill a  $\phi 25\text{--}30$  mm hole to pull the tip of the ventilation hose 9 out to the outdoor. After that, attach the ventilation hose joint 10 and top cover 11.

Finish by sealing the sleeve with putty or caulking compound at the final stage.

Top cover 11  
Ventilation hose 9  
1050 mm or more  
Inside and outside connecting cable  
Pipe  
Drain hose attached to the main unit (about 100 mm from the wall)  
400 mm or more  
Finishing material for connecting pipe  
700 mm or more  
PVC tube for drain hose (VP-30)  
PVC tube for drain hose (VP-20)

Top cover 11  
Ventilation hose 9  
Electric cable  
Finishing material for connecting pipe  
Pipe  
PVC tube for drain hose  
Heat insulation material for drainage  
Indoor unit

- If there are metal lath and conductive materials inside the wall, insert pipes and cables through the PVC tube (VP-70 or above).

In case of embedding the ventilation hose 9 into the wall for embedded piping.

- See the diagram below when embedding the ventilation hose into the wall.
- Use the enclosed hose or optional extension ventilation hose (CZ-HV3P:3m), or embedding ventilation hose (CZ-HV5P:5m) manufactured by Matsushita Electric Works, Ltd.

Ventilation hose 9  
110 mm  
Top cover 11  
Keep the screw fixing part facing upward.  
Extension ventilation hose

- In case of left piping how to insert the connecting cable and drain hose.

45°  
Ventilation Hose  
Piping  
Cable  
Drain hose

(For the right piping, follow the same procedure)

## 10.2.5. Connect The Cable To The Indoor Unit

1. The inside and outside connecting cable can be connected without removing the front grille.
  2. Connecting cable between indoor unit and outdoor unit shall be approved polychloroprene sheathed  $5 \times 1.5 \text{ mm}^2$  flexible cord, type designation 245 IEC 57 or heavier cord.
- Ensure the color of wires of outdoor unit and the terminal Nos. are the same to the indoor's respectively.
  - Earth lead wire shall be longer than the other lead wires as shown in the figure for the electrical safety in case of the slipping out of the cord from the anchorage.

Terminals on the indoor unit	1	2	3	4	
Colour of wires					
Terminals on the outdoor unit	1	2	3	4	

- Secure the cable onto the control board with the holder (clammer).

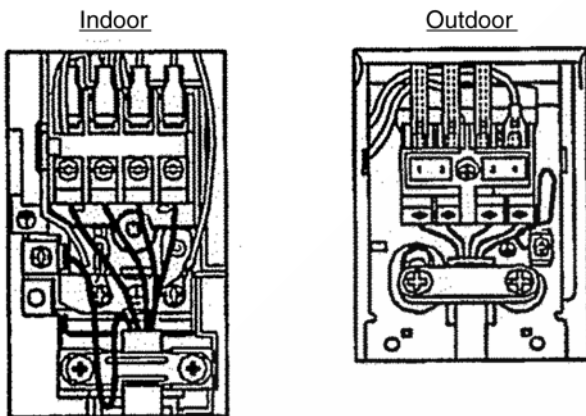

## 10.3. Outdoor Unit

### 10.3.1. Install The Outdoor Unit

- After selecting the best location, start installation according to Indoor/Outdoor Unit Installation Diagram.
1. Fix the unit on concrete or rigid frame firmly and horizontally by bolt nut ( $\varnothing 10 \text{ mm}$ ).
  2. When installing at roof, please consider strong wind and earthquake. Please fasten the installation stand firmly with bolt or nails.

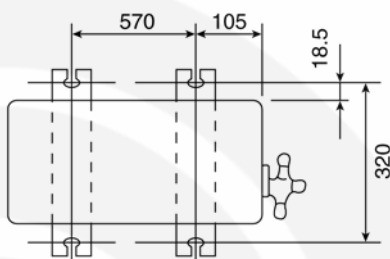

## 10.3.2. Connecting The Piping

### Connecting The Piping To Indoor Unit

Please make flare after inserting flare nut (locate at joint portion of tube assembly) onto the copper pipe.

(In case of using long piping)

Connect the piping

- Align the center of piping and sufficiently tighten the flare nut with fingers.
- Further tighten the flare nut with torque wrench in specified torque as stated in the table.

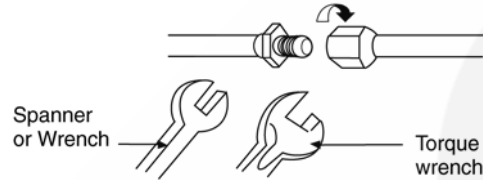

Model	Piping size (Torque)	
	Gas	Liquid
XE9EKE	3/8" [42 N•m]	1/4" [18 N•m]
XE12EKE	1/2" [55 N•m]	1/4" [18 N•m]

### Connecting The Piping To Outdoor Unit

Decide piping length and then cut by using pipe cutter. Remove burrs from cut edge. Make flare after inserting the flare nut (locate at valve) onto the copper pipe.

Align center of piping to valves and then tighten with torque wrench to the specified torque as stated in the table.

### CUTTING AND FLARING THE PIPING

1. Please cut using pipe cutter and then remove the burrs.
2. Remove the burrs by using reamer. If burrs is not removed, gas leakage may be caused. Turn the piping end down to avoid the metal powder entering the pipe.
3. Please make flare after inserting the flare nut onto the copper pipes.

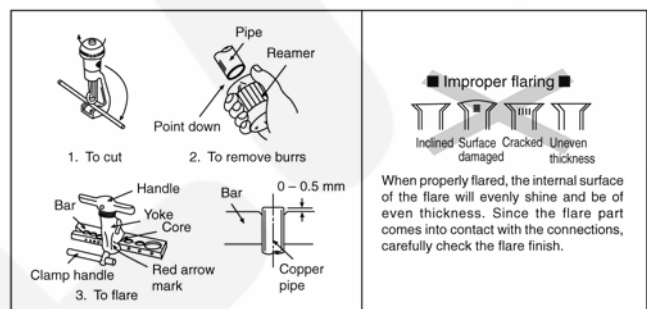

### 10.3.3. Evacuation Of The Equipment (For Europe & Oceania Destination)

WHEN INSTALLING AN AIR CONDITIONER, BE SURE TO EVACUATE THE AIR INSIDE THE INDOOR UNIT AND PIPES in the following procedure.

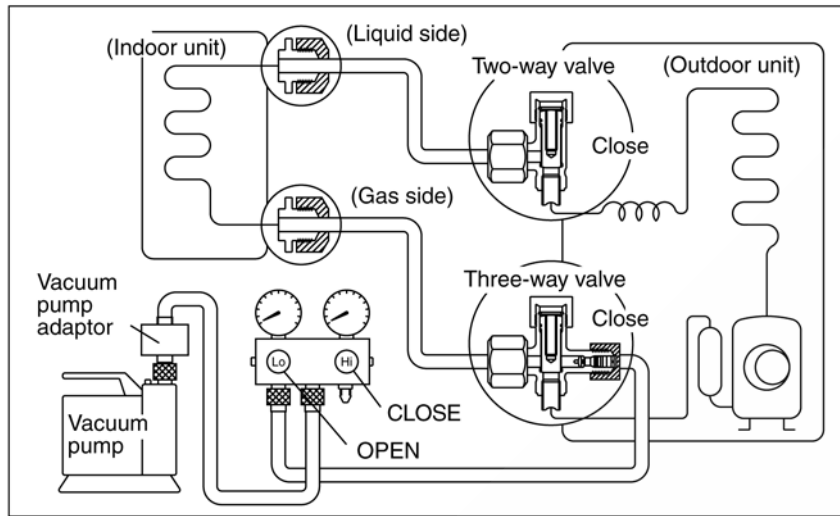







1. Connect a charging hose with a push pin to the Low and High side of a charging set and the service port of the 3-way valve.
  - Be sure to connect the end of the charging hose with the push pin to the service port.
2. Connect the center hose of the charging set to a vacuum pump with check valve, or vacuum pump and vacuum pump adaptor.
3. Turn on the power switch of the vacuum pump and make sure that the needle in the gauge moves from 0 cmHg (0 MPa) to -76 cmHg (-0.1 MPa). Then evacuate the air approximately ten minutes.
4. Close the Low side valve of the charging set and turn off the vacuum pump. Make sure that the needle in the gauge does not move after approximately five minutes. Note: BE SURE TO FOLLOW THIS PROCEDURE IN ORDER TO AVOID REFRIGERANT GAS LEAKAGE.
5. Disconnect the charging hose from the vacuum pump and from the service port of the 3-way valve.
6. Tighten the service port caps of the 3-way valve at torque of 18 N.m with a torque wrench.
7. Remove the valve caps of both of the 2-way valve and 3-way valve. Position both of the valves to "OPEN" using a hexagonal wrench (4 mm).
8. Mount valve caps onto the 2-way valve and the 3-way valve.
  - Be sure to check for gas leakage.

#### CAUTION

- If gauge needle does not move from 0 cmHg (0 MPa) to -76 cmHg (-0.1 MPa), in step 3 above take the following measure:
- If the leak stops when the piping connections are tightened further, continue working from step 3.
- If the leak does not stop when the connections are retightened, repair the location of leak.
- Do not release refrigerant during piping work for installation and reinstallation. Take care of the liquid refrigerant, it may cause frostbite.

### 10.3.4. Connect The Cable To The Outdoor Unit

1. Remove the control board cover from the unit by loosening the screw.
2. Connecting cable between indoor unit and outdoor unit shall be approved polychloroprene sheathed 5 x 1.5 mm<sup>2</sup> flexible cord, type designation 245 IEC 57 or heavier cord.

Terminals on the indoor unit	1	2	3	4	
Colour of wires					
Terminals on the outdoor unit	1	2	3	4	

3. Secure the cable onto the control board with the holder (clamer).
4. Attach the control board cover back to the original position with the screw.

# 11 Operation and Function

## 11.1. Basic Function

Inverter control, which equipped with a microcomputer in determining the most suitable operating mode as time passes, automatically adjusts output power for maximum comfort always. In order to achieve the suitable operating mode, the microcomputer maintains the set temperature by measuring the temperature of the environment and performing temperature shifting. The compressor at outdoor unit is operating following the frequency instructed by the microcomputer at indoor unit that judging the condition according to internal setting temperature and intake air temperature.

### 11.1.1. Internal Setting Temperature

Once the operation starts, remote control setting temperature will be taken as base value for temperature shifting processes. These shifting processes are depending on the air conditioner settings and the operation environment. The final shifted value will be used as internal setting temperature and it is updated continuously whenever the electrical power is supplied to the unit.

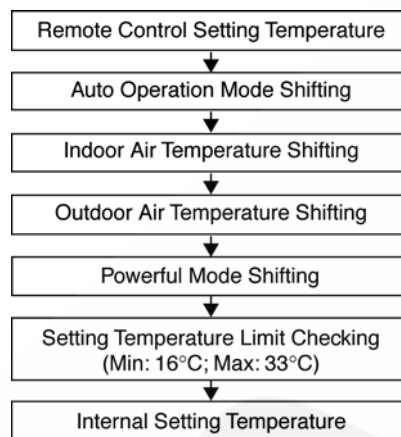

## 11.2. Airflow Direction

1. There are two types of airflow, vertical airflow (directed by horizontal vane) and horizontal airflow (directed by vertical vanes).
2. Control of airflow direction can be automatic (angles of direction is determined by operation mode, heat exchanger temperature and intake air temperature) and manual (angles of direction can be adjusted using remote control).

### 11.2.1. Vertical Airflow

Operation Mode	Airflow Direction		Vane Angle (°)				
			1	2	3	4	5
Heating	Auto with Heat Exchanger Temperature	A Upward fix	3				
		B Downward fix	64				
		C Upward fix	3				
		D Downward fix	3				
	Manual		3	17	33	49	63
Cooling, Soft Dry	Auto		8 ~ 36				
	Manual		8	15	22	30	36
Mode Judgement in Auto	Auto		8				
	Manual		8	15	22	30	36

1. Automatic vertical airflow direction can be set using remote control; the vane swings up and down within the angles as stated above. For heating mode operation, the angle of the vane depends on the indoor heat exchanger temperature as Figure 1 below. When the air conditioner is stopped using remote control, the vane will shift to close position.
2. Manual vertical airflow direction can be set using remote control; the angles of the vane are as stated above and the positions of the vane are as Figure 2 below. When the air conditioner is stopped using remote control, the vane will shift to close position.

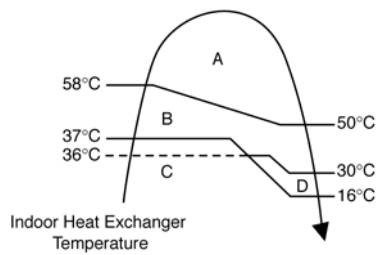

Figure 1

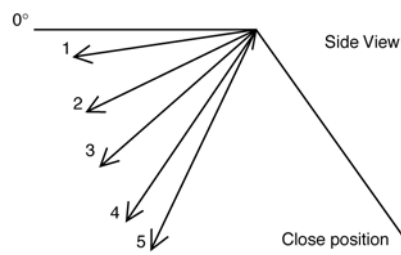

Figure 2

### 11.2.2. Horizontal Airflow

1. Automatic horizontal airflow direction can be set using remote control; the vane swings left and right within the angles as stated below. For heating mode operation, the angle of the vane depends on the indoor heat exchanger temperature as Figure 1 below.

Operation Mode		Vane Angle (°)
Heating, with heat exchanger temperature	A	65 ~ 115
	B	90
Cooling, Soft Dry and Ion		65 ~ 115

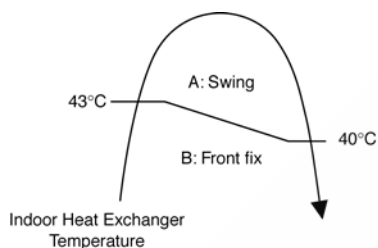

Figure 1

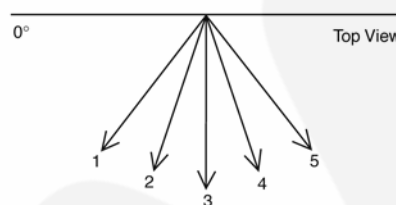

Figure 2

2. Manual horizontal airflow direction can be set using remote control; the angles of the vane are as stated below and the positions of the vane are as Figure 2 above.

Pattern	1	2	3	4	5
Airflow Direction Pattern at Remote Control					
Vane Angle (°)	90	65	78	102	115

### 11.3. Quiet operation (Cooling Mode/Cooling area of Dry Mode)

#### A. Purpose

To provide quiet cooling operation compare to normal operation.

#### B. Control condition

a. Quiet operation start condition

- When “quiet” button at remote control is pressed.

Quiet LED illuminates.

b. Quiet operation stop condition

1. When one of the following conditions is satisfied, quiet operation stops:

- a. Powerful button is pressed.
- b. Stop by OFF/ON switch.
- c. Timer “off” activates.
- d. Quiet button is pressed again.



2. When quiet operation is stopped, operation is shifted to normal operation with previous setting.
3. When fan speed is changed, quiet operation is shifted to quiet operation of the new fan speed.
4. When operation mode is changed, quiet operation is shifted to quiet operation of the new mode.
5. During quiet operation, if timer "on" activates, quiet operation maintains.
6. After off, when on back, quiet operation is not memorised.

**C. Control contents**

1. Fan speed is changed from normal setting to quiet setting of respective fan speed.  
This is to reduce sound of Hi, Me, Lo for 3dB.
2. Fan speed for quiet operation is -1 step from setting fan speed.

**11.3.1. Quiet operation (Heating)**

**A. Purpose**

To provide quiet heating operation compare to normal operation.

**B. Control condition**

- a. Quiet operation start condition
  - When "quiet" button at remote control is pressed.  
Quiet LED illuminates.
- b. Quiet operation stop condition
  1. When one of the following conditions is satisfied, quiet operation stops:
    - a. Powerful button is pressed.
    - b. Stop by OFF/ON switch.
    - c. Timer "off" activates.
    - d. Quiet button is pressed again.
  2. When quiet operation is stopped, operation is shifted to normal operation with previous setting.
  3. When fan speed is changed, quiet operation is shifted to quiet operation of the new fan speed.
  4. When operation mode is changed, quiet operation is shifted to quiet operation of the new mode, except fan only mode.
  5. During quiet operation, if timer "on" activates, quiet operation maintains.
  6. After off, when on back, quiet operation is not memorised.

**C. Control contents**

- a. Fan Speed manual
  1. Fan speed is changed from normal setting to quiet setting of respective fan speed.  
This is to reduce sound of Hi, Me, Lo for 3dB.
  2. Fan speed for quiet operation is -1 step from setting fan speed.
3. Fan Speed Auto  
Indoor FM RPM depends on pipe temp sensor of indoor heat exchanger.

**11.4. Powerful Mode Operation**

When the powerful mode is selected, the internal setting temperature will shift to achieve the setting temperature quickly.

(a) Cooling Operation

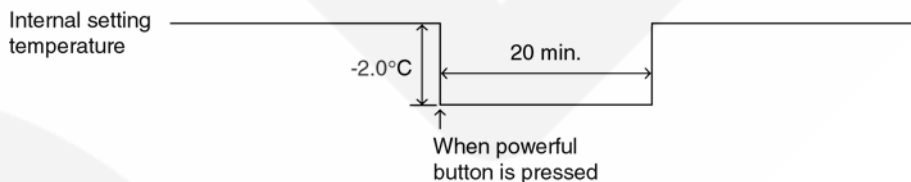

(b) Soft Dry Operation

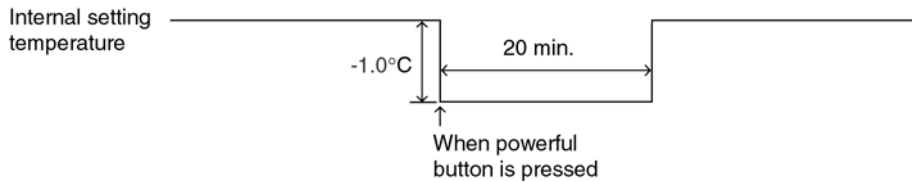

(c) Heating Operation

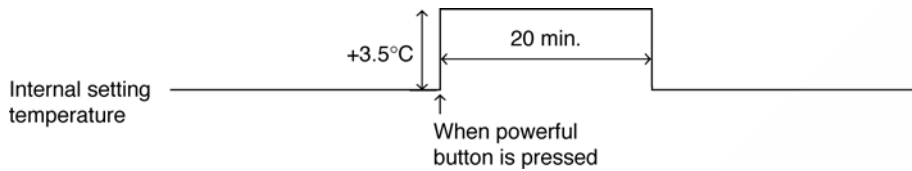

## 11.5. ON Timer Control

ON timer can be set using remote control, the unit with timer set will start operate earlier than the setting time. This is to provide a comfortable environment when reaching the set ON time.

60 minutes before the set time, indoor (at fan speed of Lo-) and outdoor fan motor start operate for 30 seconds to determine the indoor intake air temperature and outdoor air temperature in order to judge the operation starting time.

From the above judgment, the decided operation will start operate earlier than the set time as shown below.

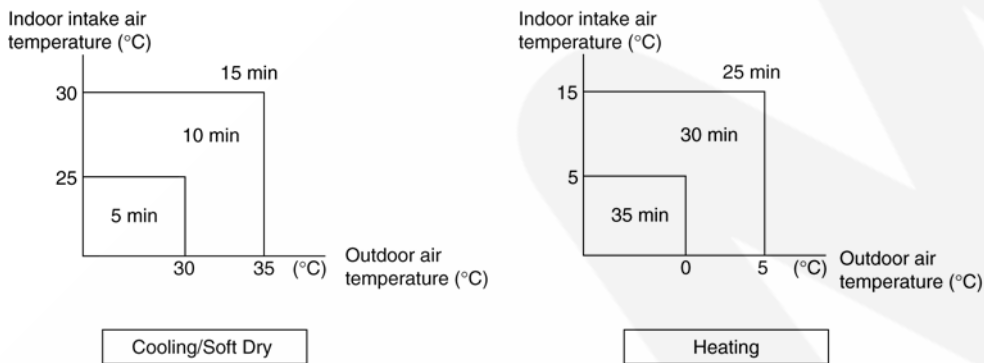

## 11.6. OFF Timer Control

OFF timer can be set using remote control, the unit with timer set will stop operate at set time.

## 11.7. Auto Restart Control

1. When the power supply is cut off during the operation of air conditioner, the compressor will re-operate within three to four minutes (there are 60 patterns of compressor restart waiting time between 2 minutes 58 seconds and 3 minutes 52 seconds to be selected randomly) after power supply resumes.
2. This type of control is not applicable during ON/OFF Timer setting.

## 11.8. Remote Control Signal Receiving Sound

- Long beep sound will be heard when:-
  - Stopping the air conditioner using ON/OFF switch.
- Short beep sound will be heard for others setting.

## 11.9. Filter Cleaning Control

- Filter cleaning function helps to:
  - Clean the filters automatically on a regular basis.
  - Avoid airflow blockage caused by dusty filter.
  - Prevent growth of mold inside the unit.
  - Improve cooling effect that saves energy consumption.
- The dust trapped on the filters surface is sucked and discharged to outdoor by a ventilation motor.
- By default, filter cleaning will run automatically once the unit is turned off if the air conditioner:
  - Operates continuously for at least 2 hours and above, and
  - Accumulative operation time is at least 2 hours and above.
- The filter surface is divided into rows. Each cleaning cycle will clean one row at a time. The numbers of rows to be cleaned will be based on the air conditioner's accumulative operation time and model purchased. The following table is an example for model 1.5 HP.

Accumulative operation time (<: less than)	Number of cleaning cycle (1 cycle: < 4 minutes)
< 2 hours	0
2 hours and < 6 hours	2
6 hours and < 9 hours	3
9 hours and < 12 hours	4
12 hours and < 15 hours	5
15 hours and < 18 hours	6
18 hours and < 21 hours	7
21 hours and < 24 hours	8

- The number of cleaning cycle depends on the fan speed setting as well. The table above is an example when the fan speed setting is HI. The number of cleaning cycle will be lesser if the fan speed setting is lower.
- You can also set the filter cleaning manually. For details, see Timer Filter Cleaning and Manual Filter Cleaning.

### 11.9.1. Auto Filter Cleaning

- Filter cleaning will run automatically after the air conditioner operation stops when air conditioner is turned off using remote control or turned off by the air conditioner timer.
- After the filter cleaning is completed, the air conditioner operation will remain off.
- The filter cleaning indicator light will move to left or right when filter cleaning is in progress.
- Filter cleaning in progress will be cancelled if:
  - Certain buttons on the remote control are pressed.
  - The air conditioner main unit's movable front panel is lifted up.
  - There is a power failure.

### 11.9.2. Force Filter Cleaning

- Once the air conditioner operation time exceeds 24 hours, the unit is forced to run filter cleaning.
- After the filter cleaning is completed, the air conditioner operation will resume automatically.

### 11.9.3. Timer Filter Cleaning

- Filter cleaning timer can be set to run at a specified time daily, given that the air conditioner accumulative operation time is at least 30 minutes and above.
- Filter cleaning timer overrides air-conditioner's timer in any given setting.
- Once filter cleaning timer starts, air conditioner operation will stop. After the filter cleaning is completed, the air conditioner operation will resume automatically.

### 11.9.4. Manual Filter Cleaning

- Manual filter cleaning can be performed a comprehensive filter cleaning.
- A comprehensive filter cleaning may take less than an hour to complete.
- This operation has the highest priority over other operation modes. After the filter cleaning is completed, the air conditioner operation will resume automatically.

## 11.10. Ventilation Control

- To circulate the indoor air.
- The ventilation operation is enable by pressing the VENTILATION Button. (As a default setting, ventilation will be turned on automatically once the air conditioner operation starts).

### 11.10.1. Simultaneous Operation

- Operates simultaneously with Auto/Cooling/Drying operation.
- Press **VENTILATION** button at remote control repeatedly to select your desired ventilation setting. Auto/Cooling/Drying operation remains as normal regardless of ventilation setting.

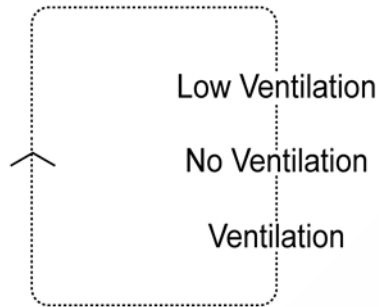

- When OFF/ON button at remote control is pressed, all of the air conditioner operations are turned off.

### 11.10.2. Independent Operation

- Ventilation operates independently.
- Ventilation can be turned on when the air conditioner is in non-operation mode.
- Fan speed in this setting remains as AUTO.
- Press OFF/ON button at remote control to turn off the ventilation operation.

# 12 Protection Control

## 12.1. Time Delay Safety Control

- Compressor will not start for three minutes after stop of the operation.

## 12.2. 30 Seconds Forced Operation

- Once compressor starts the operation, it will not stop its operation for 30 seconds. However, it can be stopped with the remote controller or the Auto button on the indoor unit.

## 12.3. Total Running Current Control

1. When the total running current exceeds I1, compressor operation frequency is reduced. If it reaches below I1, the operation frequency is increased. (But, up to programmed frequency.)
2. If total running current exceeds I2, compressor is stopped immediately.
3. If it happens three (3) times within 20 minutes, operation will be stopped and Timer LED blinks. ("F98" is activating.)

	Running current	CS-XE9EKE	CS-XE12EKE
Cooling	I1	3.7A	5.8A
	I2	25.0A	25.0A
Heating	I1	5.9A	8.2A
	I2	25.0A	25.0A

## 12.4. IPM (Power transistor) Protection Control (DC Peak detection)

### Abnormal Current Control

- If inverter load current (DC peak) exceeds a rated value, compressor will be stopped immediately. When the excess occurs within 30 seconds after operation, it restarts in 1 minute and when after 30 seconds, restarts in 2 minutes.
- If the excess continuously occurs 7 times within 30 minutes after compressor starts, the unit will be stopped and timer LED on the indoor unit will be blinking. ("F99" is to be confirmed.)

### IPM Overheating Prevention Control

- If temperature of IPM exceeds 103°C, compressor will be stopped. It will restart in 2 minutes. Temperature for restarting: 90°C.
- If the excess occurs 7 times within 30 minutes after compressor starts, the compressor will be stopped and timer LED on the indoor unit will be blinking. ("F96" is to be confirmed.)

## 12.5. Compressor Overheating Prevention Control

1. If discharge pipe temperature exceeds 100°C, compressor power will be limited.
2. If discharge pipe temperature exceeds 112°C, compressor will be stopped.
3. If the above excess occurs 4 times per 10 minutes, timer LED will be blinking. ("F97" is to be confirmed.)

## 12.6. Outdoor High Pressure Prevention Control (Cooling and Dry operations)

1. If outdoor heat exchanger temperature exceeds 63°C in cooling or dry operation, compressor will be stopped.
2. Timer LED is not blinking. ("F95" is memorized, then.)

## 12.7. Compressor Protection Control (Refrigeration Cycle Abnormality)

### In cooling and Dry operations

1. When compressor is operated continuously for 5 minutes in the maximum cooling power: a running current of 0.7 - 1.4A and "[Indoor intake air temperature] - [Indoor heat exchanger temperature]" < 4°C, compressor will be stopped.
2. If the above excess occurs twice for 20 minutes, timer LED is to be blinking. ("F91" is to be confirmed.)

### In Heating operation

1. When compressor is operated continuously for 5 minutes in the rated heating power: a running current of 0.7 - 1.4A and "[Indoor heat exchanger temperature] - [Indoor intake air temperature]" < 5°C, compressor will be stopped.
2. If the above excess occurs twice for 20 minutes, timer LED is to be blinking. ("F91" is to be confirmed.)

## **12.8. Four-way Valve Operation Detection Control (Switching Abnormality between Cooling and Heating)**

### **In Cooling operation**

1. When indoor heat exchanger temperature exceeds 45°C in 4 minutes after compressor starts, compressor will be stopped.
2. If the above excess occurs 4 times per 30 minutes, timer LED is to be blinking. ("F11" is to be confirmed.)

### **In Heating operation**

1. When indoor heat exchanger temperature is below 0°C in 4 minutes after compressor starts, compressor will be stopped.
2. If the above excess occurs 4 times per 30 minutes, timer LED is to be blinking. ("F11" is to be confirmed.)

## **12.9. Anti-Freezing Control (Cooling and Dry operations)**

### **Limit of Cooling power**

1. When temperature of indoor heat exchanger is below 5°C, operating frequency will be decreased.
2. When temperature of indoor heat exchanger exceeds 7°C, operating frequency will be increased. (But, up to programmed frequency.)
3. When temperature of indoor heat exchanger is below 0°C continuously for 6 minutes, compressor will be stopped.
4. Timer LED is not blinking. ("H99" is memorized, then.)

### **Limit of Indoor fan speed**

- When temperature of indoor heat exchanger is below 6°C (2°C at Dry) continuously for 6 minutes, indoor fan speed will be increased by 50 rpm.

## **12.10. Outdoor Air Temperature Control**

### **In Cooling and Dry operations**

1. When outdoor air temperature is below 25°C, the maximum power will be limited up to about 80 - 100% of the rated power.
2. When outdoor air temperature is below 18°C, the maximum power will be limited up to about 50 - 100% of the rated power.
3. When outdoor air temperature is below 11°C, the maximum power will be limited up to about 26 - 81% of the rated power.

## **12.11. Indoor Intake Air Temperature Control (Heating operation)**

1. When indoor air temperature is 35°C or more, the maximum power will be limited up to the rated power.
2. When fan speed is set at "Lo" and intake air temperature is below 21°C, the maximum power will be limited up to the rated power.

# 13 Servicing Mode

## 13.1. Auto OFF/ON Button

This button is used to pump down the air conditioner during servicing or transferring of outdoor unit.

1. It can be used to operate the air conditioner in limited function if remote control is misplaced or malfunction.

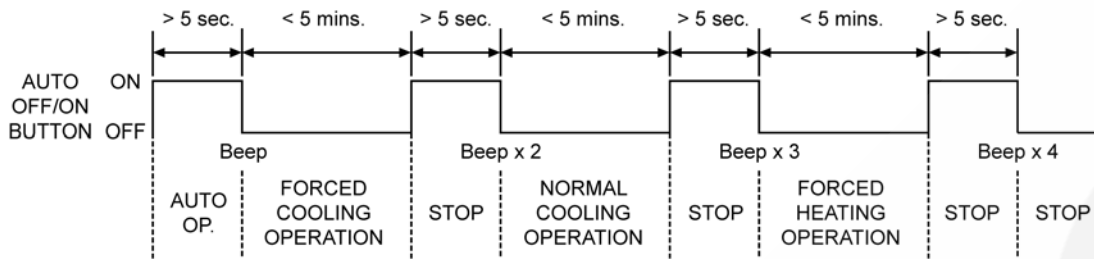

- Auto operation will start when Auto OFF/ON Button is pressed and released within 5 seconds.
  - Within 5 minutes of each operation, if the Auto OFF/ON Button is pressed again for more than 5 seconds the air conditioner will switch to another operation after “Beep” sound.
2. The Auto OFF/ON Button may be used together with remote control to set / change the advanced setting of air conditioner operation.

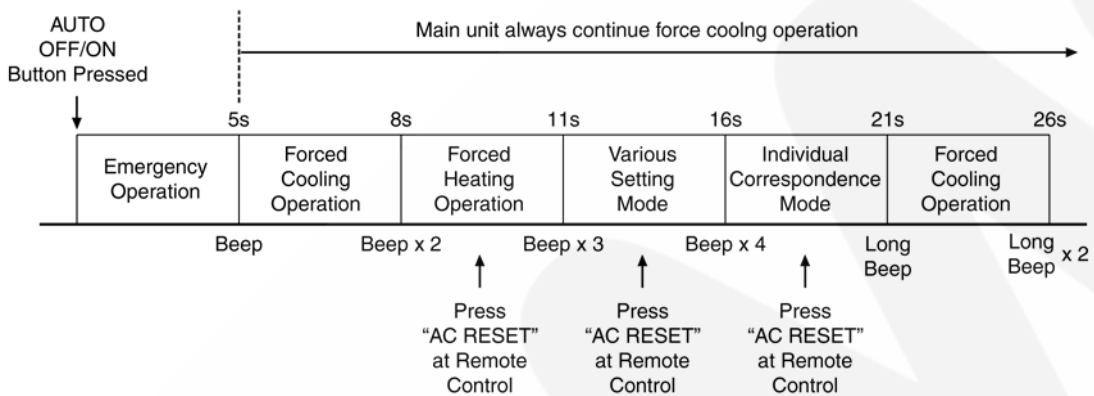

- Press and hold AUTO OFF/ON Button for more than 5 seconds, the air conditioner always operate force cooling operation.
- Press and hold AUTO OFF/ON Button until 2 Beep sounds are heard, the forced heating operation is at standby condition.
- Press and hold AUTO OFF/ON Button until 3 Beep sounds are heard, the various setting mode is at standby condition.
- Press and hold AUTO OFF/ON Button until 4 Beep sounds are heard, the individual correspondence mode is at standby condition.
- During standby condition, when the indoor unit receives “AC RESET” signal (Beep sound is heard) from remote control, the corresponding mode will be activated.

## 13.2. Various Setting Mode

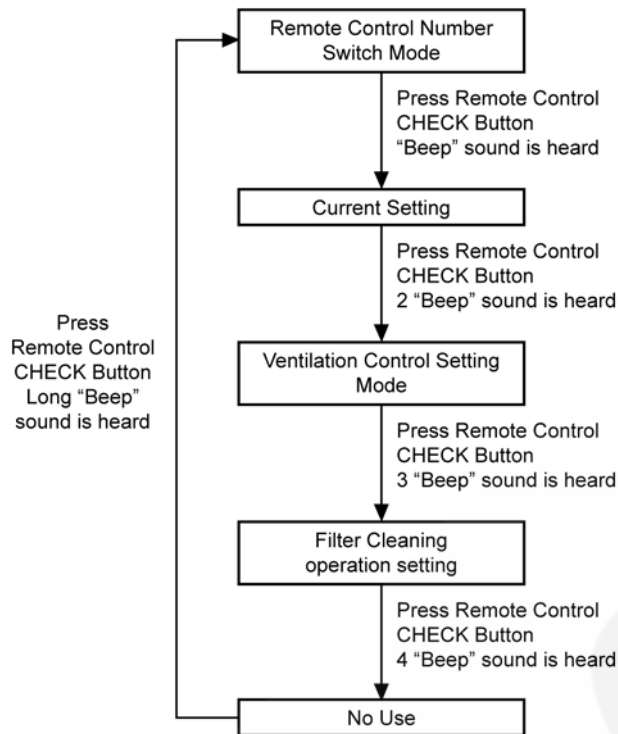

### 13.2.1. Remote Control Number Switch Mode

- Set remote control number through receiving signal from remote control. (Please refer to Select Remote Control Transmission Code).

### 13.2.2. Current Setting

- Choose the Current Setting by pressing AUTO OFF/ON button.



### 13.2.3. Ventilation Control Setting Mode

- Set the ventilation operation and auto filter cleaning operation by pressing Auto OFF/ON Button.

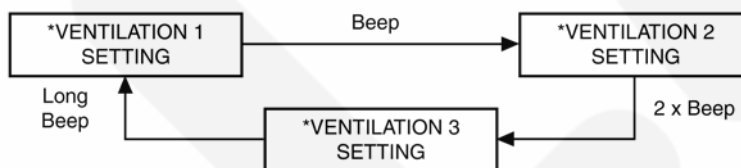

- \* VENTILATION 1: Enable ventilation operation and auto filter cleaning.
- \* VENTILATION 2: Disable ventilation operation and auto filter cleaning.
- \* VENTILATION 3: Ventilation only and no filter cleaning.

- If there is no operation, or receives any remote control signal within 5 minutes, the setting mode quits.



### 13.2.4. Filter Cleaning Operation Setting

Choose the operation setting by pressing AUTO OFF/ON button.

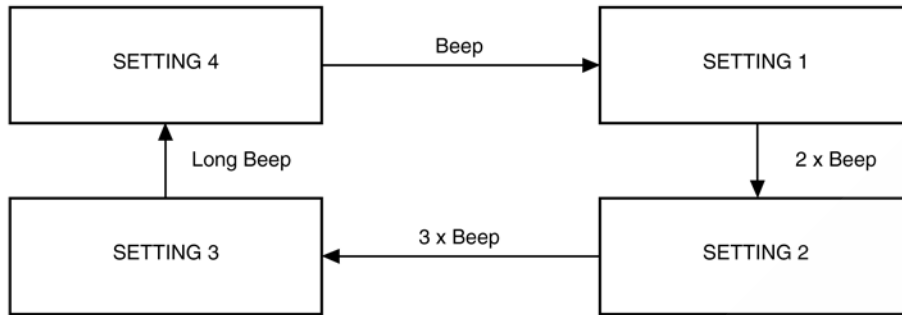

Setting	Operation
1	<ul style="list-style-type: none"> <li>Filter cleaning will run automatically after the air conditioner operation stops (air conditioner is turned off using remote control).</li> <li>After the filter cleaning is completed, the air conditioner operation will remain off.</li> </ul>
2**	<ul style="list-style-type: none"> <li>Filter cleaning will run automatically before the air conditioner operation starts (air conditioner is either turned on using remote control or turned on by the air conditioner timer).</li> <li>After the filter cleaning is completed, the air conditioner operation will start automatically.</li> </ul>
3**	<ul style="list-style-type: none"> <li>Filter cleaning will run automatically before the air conditioner operation starts (air conditioner is turned on using remote control).</li> <li>After the filter cleaning is completed, the air conditioner operation will start automatically.</li> </ul>
4	<ul style="list-style-type: none"> <li>Filter cleaning will run automatically after the air conditioner operation stops (air conditioner is either turned off using remote control or turned off by the air conditioner timer).</li> <li>After the filter cleaning is completed, the air conditioner operation will remain off.</li> </ul>

\*\* The setting is valid only if the following conditions are fulfilled:

1. The air conditioner is turned off for at least 3 minutes.
2. The air conditioner has operated continuously for at least 2 hours in previous operation.

- If there is no operation, or receives any remote control signal within 5 minutes, the setting mode quits.

### 13.3. Individual Correspondence Mode

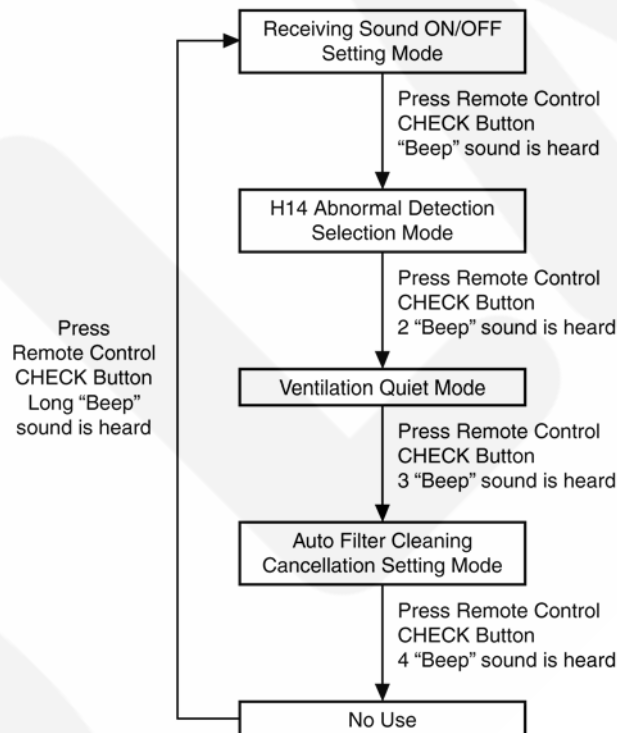

- During Receiving Sound ON/OFF setting mode, press AUTO OFF/ON Button to toggle the Receiving sound.

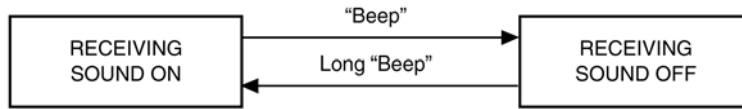

- During H14 Abnormal Detection Selection Mode, press AUTO OFF/ON Button to toggle the Abnormal detection.



- During Ventilation Quiet mode, press AUTO OFF/ON Button to toggle the Ventilation setting.



- During Auto Filter Cleaning cancellation setting mode, press AUTO OFF/ON Button to toggle the Auto Filter Cleaning cancellation setting.

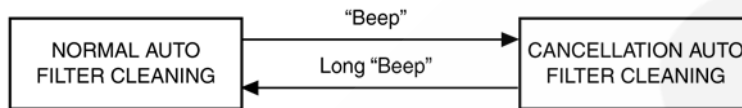

- If there is no operation, or receives any remote control signal within 5 minutes, the setting mode quits.

### 13.4. Select Remote Control Transmission Code

- There are 4 type of remote control transmission code could be selected and stored in EEPROM of indoor unit. The indoor unit will only operate when received signal with same transmission code from remote control. This could prevent signal interference when there are 2 or more indoor unit installed nearby together.
- To change remote control transmission code, short or open jumpers at the remote control printed circuit board.

Remote Control Printed Circuit Board	Transmission Code Combination		
	J - A	J - B	Remote Control No.
	Short	Open	A (Default)
	Open	Open	B
	Short	Short	C
	Open	Short	D

- Under various setting mode, after select the transmission code combination of remote control, press any button of remote control to transmit a signal to indoor unit. The transmission code will be stored in EEPROM.
- After signal is received, the various setting mode is cancelled and return to normal operation.

# 14 Demo Mode

- The purpose of Demo Mode is to demonstrate the filter cleaning function.
- The Demo Mode can be activated by using AUTO OFF/ON button.

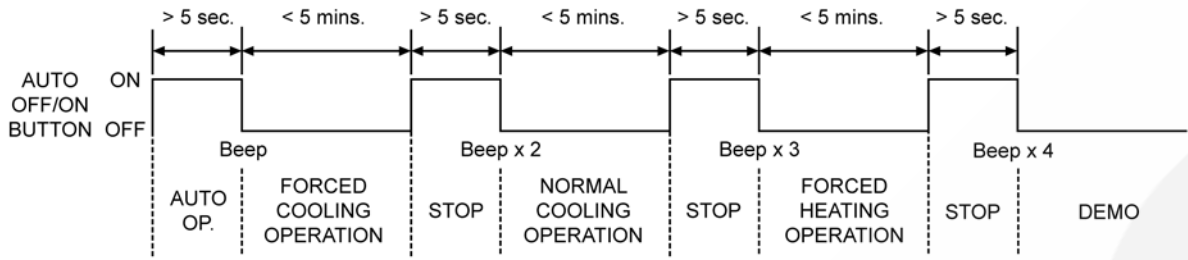

- The Demo Mode is activated by AUTO OFF/ON button. (Beep × 4)
- The Demo Mode activation does not start the demonstration.
- The demonstration starts after received remote control ON signal.
- Demo operation:
  - Zone A**
    - Normal operation (follow remote control setting) for 2 minutes.
  - Zone B**
    - a. Filter cleaning operation for 1 round-trip.
    - b. Then return to normal operation. (Auto Swing operates but Indoor Fan stops)
- After step b. operates for 11 minutes, return to step a.
- During step b. when cleaning button is pressed, return to step a.
- During demonstration, if other remote control button (Except ON/OFF button) is pressed, the demo operation return to **(Zone A)**.
- The demonstration stop after received remote control OFF signal.
- Demo Mode is deactivated by AUTO OFF/ON button. (Beep × 3, then long Beep × 1)

# 15 Troubleshooting Guide

## 15.1. Refrigeration Cycle System

In order to diagnose malfunctions, make sure that there are no electrical problems before inspecting the refrigeration cycle. Such problems include insufficient insulation, problem with the power source, malfunction of a compressor and a fan.

The normal outlet air temperature and pressure of the refrigeration cycle depends on various conditions, the standard values for them are shown in the table to the right.

Normal Pressure and Outlet Air Temperature (Standard)

	Gas pressure MPa (kg/cm <sup>2</sup> G)	Outlet air temperature (°C)
Cooling Mode	0.9 ~ 1.2 (9 ~ 12)	12 ~ 16
Heating Mode	2.3 ~ 2.9 (23 ~ 29)	36 ~ 45

- ★ Condition:
- Indoor fan speed; High
  - Outdoor temperature 35°C at cooling mode and 7°C at heating mode.
  - Compressor operates at rated frequency

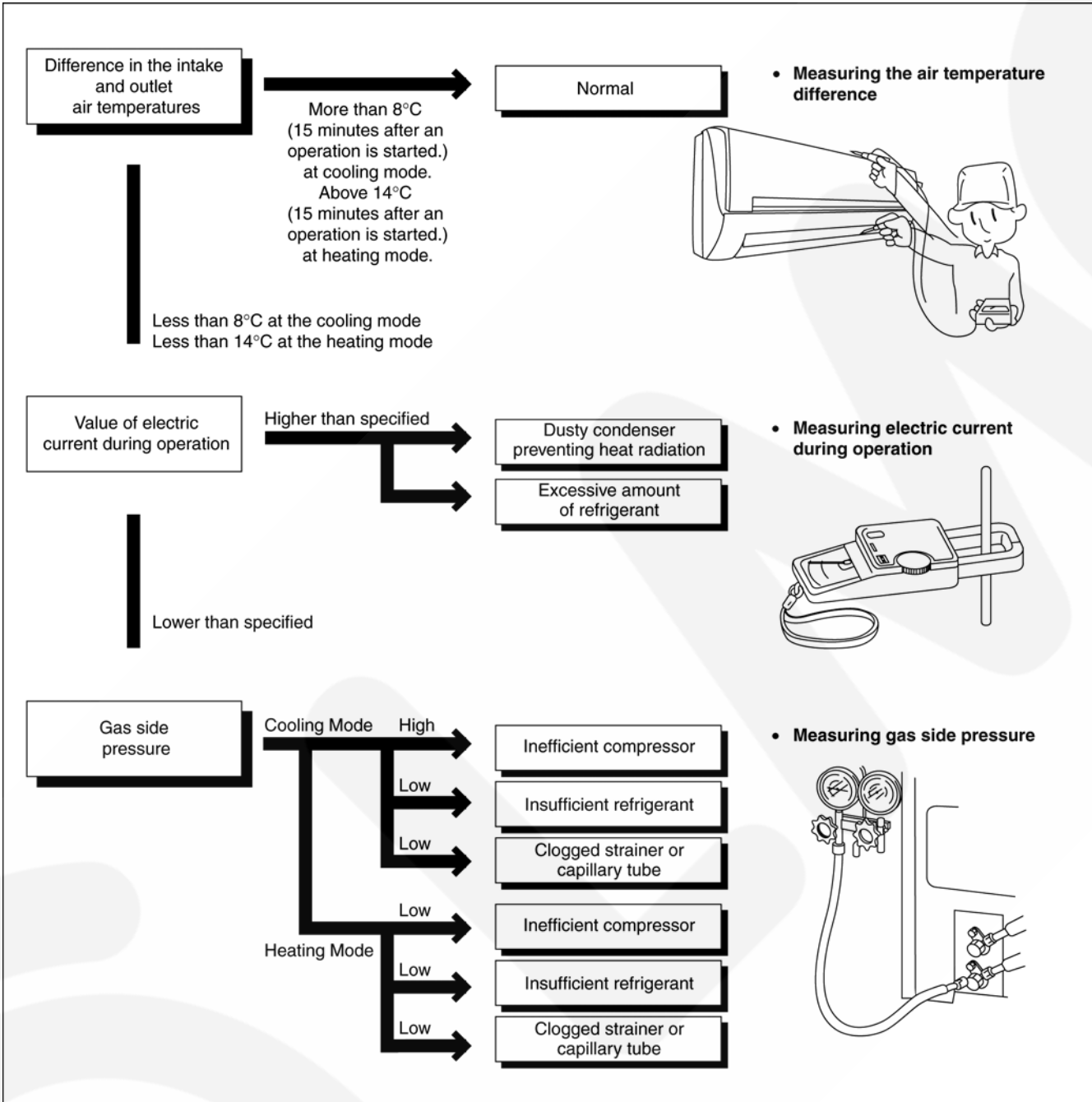

## 15.2. Relationship Between The Condition of The Air Conditioner and Pressure and Electric Current

Condition of the air conditioner	Cooling Mode			Heating Mode		
	Low Pressure	High Pressure	Electric current during operation	Low Pressure	High Pressure	Electric current during operation
Insufficient refrigerant (gas leakage)	↘	↘	↘	↘	↘	↘
Clogged capillary tube or Strainer	↘	↘	↘	↗	↗	↗
Short circuit in the indoor unit	↘	↘	↘	↗	↗	↗
Heat radiation deficiency of the outdoor unit	↗	↗	↗	↘	↘	↘
Inefficient compression	↗	↘	↘	↗	↘	↘

- Carry out the measurements of pressure, electric current, and temperature fifteen minutes after an operation is started.

## 15.3. Breakdown Self Diagnosis Function

### 15.3.1. Self Diagnosis Function (Three Digits Alphanumeric Code)

- Once abnormality has occurred during operation, the unit will stop its operation, and Timer.
- Although Timer LED goes off when power supply is turned off, if the unit is operated under a breakdown condition, the LED will light up again.
- In operation after breakdown repair, the Timer LED will no more blink. The last error code (abnormality) will be stored in IC memory.

#### • To make a diagnosis

1. Timer LED start to blink and the unit automatically stops the operation.
2. Press the CHECK button on the remote controller continuously for 5 seconds.
3. “- -” will be displayed on the remote controller display.  
Note: Display only for “- -”. (No transmitting signal, no receiving sound and no Power LED blinking.)
4. Press the “TEMP” ▲ or ▼ button on the remote controller. The code “H00” (no abnormality) will be displayed and signal will be transmitted to the main unit.
5. Every press of the button (up or down) will increase abnormality numbers and transmit abnormality code signal to the main unit.
6. When the latest abnormality code on the main unit and code transmitted from the remote controller are matched, power LED will light up for 30 seconds and a beep sound (continuously for 4 seconds) will be heard. If no codes are matched, power LED will light up for 0.5 seconds and no sound will be heard.
7. The breakdown diagnosis mode will be canceled unless pressing the CHECK button continuously for 5 seconds or operating the unit for 30 seconds.

AC

8. The LED will be off if the unit is turned off or the RESET button on the main unit is pressed.

#### • To display memorized error (Protective operation) status:

1. Turn power on.
2. Press the CHECK button on the remote controller continuously for 5 seconds.
3. “- -” will be displayed on the remote controller display.  
Note: Display only for “- -”. (No transmitting signal, no receiving sound and no Power LED blinking.)
4. Press the “TEMP” or button on the remote controller. The code “H00” (no abnormality) will be displayed and signal will be transmitted to the main unit. The power LED lights up. If no abnormality is stored in the memory, three beeps sound will be heard.
5. Every press of the button (up or down) will increase abnormality numbers and transmit abnormality code signal to the main unit.
6. When the latest abnormality code on the main unit and code transmitted from the remote controller are matched, power LED will light up for 30 seconds and a beep sound (continuously for 4 seconds) will be heard. If no codes are matched, power LED will light up for 0.5 seconds and no sound will be heard.
7. The breakdown diagnosis mode will be canceled unless

pressing the CHECK button continuously for 5 seconds or operating the unit for 30 seconds.

8. The same diagnosis can be repeated by turning power on again.

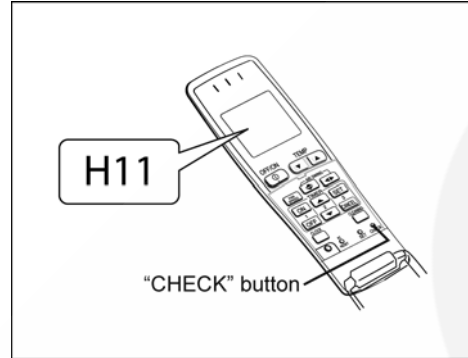

#### • To clear memorized error (Protective operation) status after repair

1. Turn power on.
2. Press the AUTO button for 5 seconds (A beep receiving sound) on the main unit to operate the unit at Forced Cooling Operation modes.
3. Press the CHECK button on the remote controller.

#### • Temporary Operation (Depending on breakdown status)

1. Press the AUTO button (A beep receiving sound) on the main unit to operate the unit. (Remote control will become possible.)
2. The unit can temporarily be used until repaired.

Error Code	Operation	Temporary items
H23	Cooling	Emergency Operation with limited power
H27, H28	Cooling, Heating	

## 15.4. Error Codes Table

Diagnosis display	Abnormality / Protection control	Abnormality Judgement	Emergency operation	Primary location to verify
H00	No abnormality detected	—	Normal operation	—
H11	Indoor / Outdoor abnormal communication	> 1 min after starting operation	Indoor fan operation only	<ul style="list-style-type: none"> <li>Internal / external cable connections</li> <li>Indoor / Outdoor PCB</li> </ul>
H14	Indoor intake air temperature sensor abnormality	Continue for 5 sec.	—	<ul style="list-style-type: none"> <li>Intake air temperature sensor (detective or disconnected)</li> </ul>
H15	Outdoor compressor temperature sensor abnormality	Continue for 5 sec.	—	<ul style="list-style-type: none"> <li>Compressor temperature sensor (detective or disconnected)</li> </ul>
H16	Outdoor Current Transformer open circuit	—	—	<ul style="list-style-type: none"> <li>Outdoor PCB</li> <li>IPM (Power transistor) module</li> </ul>
H19	Indoor fan motor mechanism locked	7 times occurrence continuously	—	<ul style="list-style-type: none"> <li>Indoor PCB</li> <li>Fan motor</li> </ul>
H23	Indoor heat exchanger temperature sensor abnormality	Continue for 5 sec.	O (Cooling only)	<ul style="list-style-type: none"> <li>Heat exchanger temperature sensor (detective or disconnected)</li> </ul>
H24	Indoor heat exchanger temperature sensor 2 abnormality	Continue for 5 sec.	—	<ul style="list-style-type: none"> <li>Heat exchanger temperature sensor 2 (detective or disconnected)</li> </ul>
H27	Outdoor intake air temperature sensor abnormality	Continue for 5 sec.	O	<ul style="list-style-type: none"> <li>Outdoor temperature sensor (detective or disconnected)</li> </ul>
H28	Outdoor heat exchanger temperature sensor abnormality	Continue for 5 sec.	O	<ul style="list-style-type: none"> <li>Outdoor heat exchanger temperature sensor (detective or disconnected)</li> </ul>
H30	Outdoor discharge air temperature sensor abnormality	Continue for 5 sec.	—	<ul style="list-style-type: none"> <li>Outdoor temperature sensor (detective or disconnected)</li> </ul>
H33	Indoor / Outdoor wrong connection	—	—	<ul style="list-style-type: none"> <li>Indoor / Outdoor supply voltage</li> </ul>
H38	Indoor / Outdoor mismatch (brand code)	—	—	—
H50	Ventilation motor abnormality	7 times occurrence continuously	—	<ul style="list-style-type: none"> <li>Indoor PCB</li> <li>Ventilation motor</li> </ul>
H51	Nozzle lock abnormality	2 times occurrence continuously	—	<ul style="list-style-type: none"> <li>Nozzle</li> </ul>
H52	Limit switch abnormality	—	—	<ul style="list-style-type: none"> <li>Indoor PCB</li> </ul>
H97	Outdoor fan motor mechanism locked	2 times occurrence within 30 minutes	—	<ul style="list-style-type: none"> <li>Outdoor PCB</li> <li>Fan motor</li> </ul>
H98	Indoor high pressure protection	—	—	<ul style="list-style-type: none"> <li>Air filter dirty</li> <li>Air circulation short circuit</li> </ul>
H99	Indoor heat exchanger anti-freezing protection	—	—	<ul style="list-style-type: none"> <li>Insufficient refrigerant</li> <li>Air filter dirty</li> </ul>
F11	Cooling / Heating cycle changeover abnormality	4 times occurrence within 30 minutes	—	<ul style="list-style-type: none"> <li>4-way valve</li> <li>V-coil</li> </ul>
F90	PFC control	4 times occurrence within 10 minutes	—	<ul style="list-style-type: none"> <li>Voltage at PFC</li> </ul>
F91	Refrigeration cycle abnormality	2 times occurrence within 20 minutes	—	<ul style="list-style-type: none"> <li>No refrigerant (3-way valve is closed)</li> </ul>
F93	Compressor rotation failure	4 times occurrence within 20 minutes	—	<ul style="list-style-type: none"> <li>Compressor</li> </ul>
F95	Cool high pressure protection	4 times occurrence within 20 minutes	—	<ul style="list-style-type: none"> <li>Outdoor refrigerant circuit</li> </ul>
F96	IPM (power transistor) overheating protection	4 times occurrence within 30 minutes	—	<ul style="list-style-type: none"> <li>Excess refrigerant</li> <li>Improper heat radiation</li> <li>IPM (Power transistor)</li> </ul>
F97	Outdoor compressor overheating protection	4 times occurrence within 10 minutes	—	<ul style="list-style-type: none"> <li>Insufficient refrigerant</li> <li>Compressor</li> </ul>
F98	Total running current protection	3 times occurrence within 20 minutes	—	<ul style="list-style-type: none"> <li>Excess refrigerant</li> <li>Improper heat radiation</li> </ul>
F99	Outdoor Direct Current (DC) peak detection	7 times occurrence continuously	—	<ul style="list-style-type: none"> <li>Outdoor PCB</li> <li>IPM (Power transistor)</li> <li>Compressor</li> </ul>

Note:

“O” - Frequency measured and fan speed fixed.

The memory data of error code is erased when the power supply is cut off, or press the Auto Switch until “beep” sound heard following by pressing the “CHECK” button at remote controller.

Although operation forced to stop when abnormality detected, emergency operation is possible for certain errors (refer to Error Codes Table) by using remote controller or Auto Switch at indoor unit. However, the remote controller signal receiving sound is changed from one “beep” to four “beep” sounds.

## 15.5. Movable Front Panel Malfunction

- Movable front panel does not opens/fully opens during air conditioner operation.
- This happen when the front panel has been interrupted during operations.
- Follow below instructions to reset the air conditioner memory.
  1. Press OFF/ON button to stop the air conditioner operation.
  2. Then use a sharp end object to press the RESET button.



## 15.6. Initial Operation After Installation

- When the first air conditioner operation is initialized, filter cleaning will run one cycle automatically.
  - This is a normal operation to make sure the filter cleaning device is able to move smoothly.
  - Filter cleaning will not be terminated by pressing any of the remote control buttons. Filter cleaning will stop by itself after operates for one cycle.

## 15.7. Error During Filter Cleaning Operation

- Filter cleaning indicator is blinking at every half a second interval.
  - The filter cleaning device is jammed because the filter is not installed correctly.
  - The filter cleaning device is malfunction.
- Filter cleaning indicator is blinking at every 2 seconds interval.
  - The filter cleaning device is malfunction.
  - Printed circuit board is malfunction.
- The filter cleaning device stops half way in the middle of the main unit.
  - To return the filter cleaning device to the original position, press CLEANING button at the remote control and hold for more than 5 seconds.
  - To change the filter cleaning device from right side (original position) to left side, press CLEANING button at the remote control and hold for more than 5 seconds, then press Timer increment button at remote control.

## 15.8. Error During Ventilation Operation

- Ventilation indicator is blinking at every half a second interval.
  - Ventilation fan motor may be locked due to piles of dust accumulated in the ventilation area and fails to discharge.
  - Printed circuit board is malfunction.
  - Ventilation fan motor is malfunction.



# 16 Disassembly and Assembly Instructions

## 16.1. Indoor Electronic Controller, Auto Cleaning, Cross Flow Fan and Fan Motor Removal Procedures

1. Open and release the Intake Grille complete (Front). (Fig. 1)

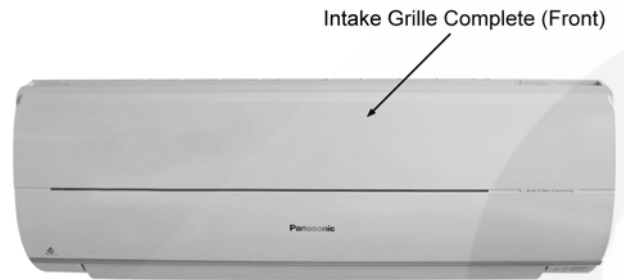

Fig. 1

- 2. Remove the Intake Grille Complete (Top). (Fig. 2)
- 3. Remove the Front Grille Complete (Right) by releasing the 2 screws. (Fig. 2)
- 4. Remove the Front Grille Complete (Left) by releasing the 2 screws. (Fig. 2)
- 5. Remove the 2 Plate Cover. (Fig. 2)

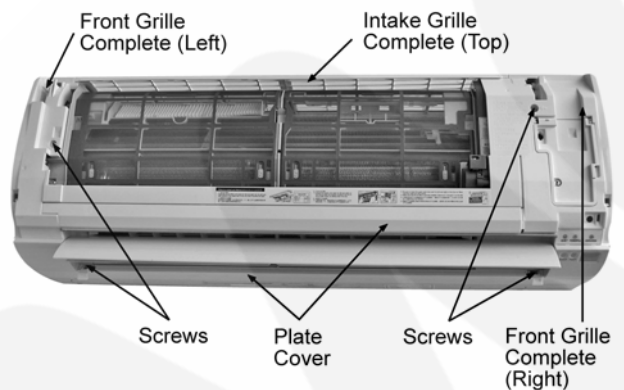

Fig. 2

6. Remove the Control Board Cover. (Fig. 3)



Fig. 3

- 7. Remove the Particular Piece by screw. (Fig. 4)
- 8. Remove the Earth Wire screws. (Fig. 4)
- 9. Releasing CN-STM4, CN-STM2, CN-STM1, CN-ACLN, CN-STM3, CN-SW & CN-DISP (Fig. 4)

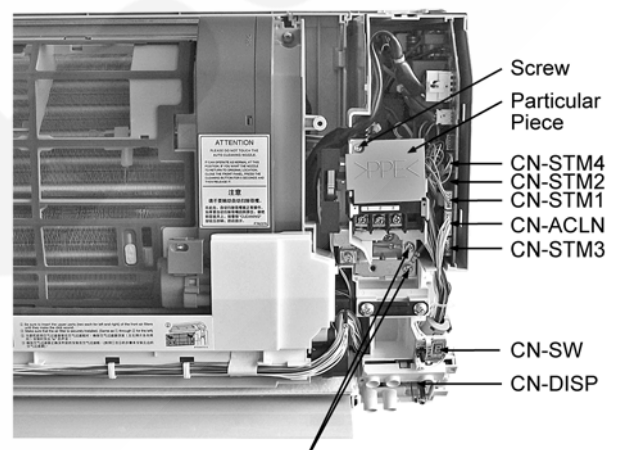

Fig. 4

10. Releasing the CN-FM, CN-FB, CN-CLNSW, CN-TH, CN-SIDESW, CN-VENT & CN-AUTO. (Fig. 5)

11. Releasing the 2 Terminals (Brown and Black)

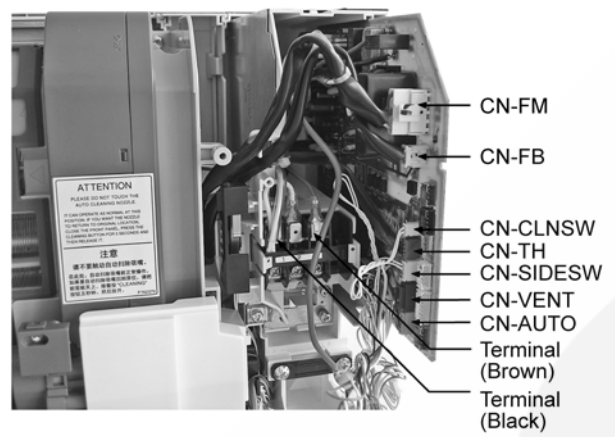

Fig. 5

12. Releasing the AC02 terminal.

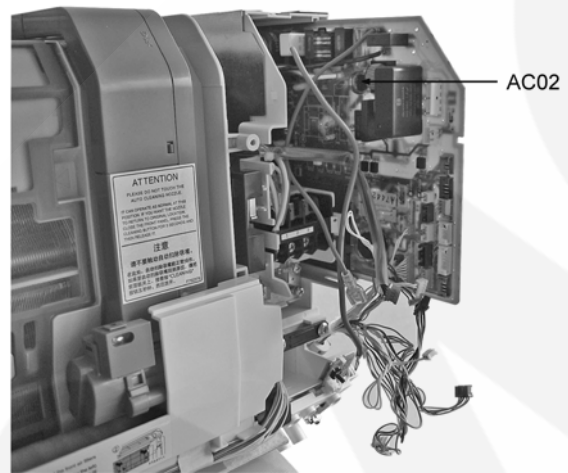

Fig. 6

13. Slide out the Indoor Electronic Controller. (Fig. 7)

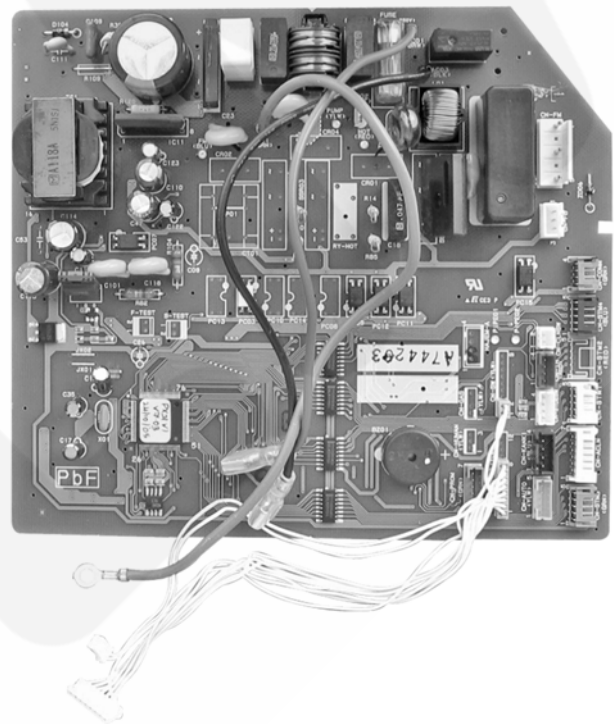

Fig. 7

14. Remove the Auto Cleaning Complete by releasing the 5 screws. (Fig. 8). For detailed instructions, please refer to 16.2 Filter Cleaning Device Complete Removal Instructions.

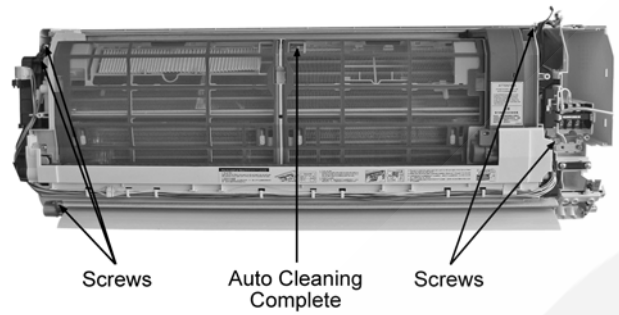

Fig. 8

15. Remove the Control Board by releasing the screw. (Fig. 9)

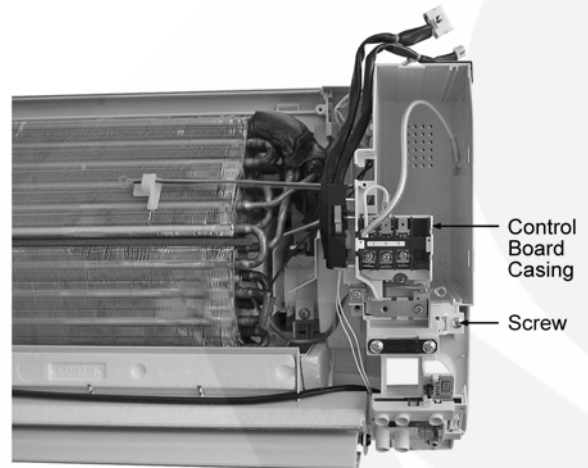

Fig. 9

16. Pull out the Drain Hose (behind the Discharge Grille) from outlet to remove the Discharge Grille. (Fig. 10)

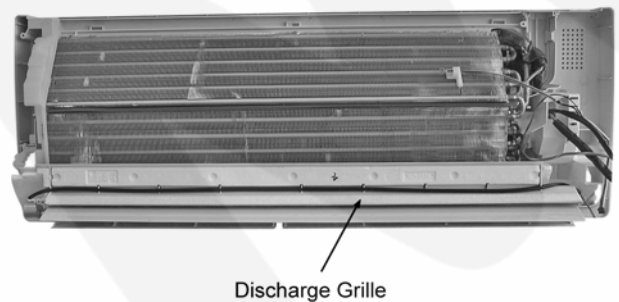

Fig. 10

17. Release the 3 screws Fan Motor Cover. (Fig. 11)

18. By pressing down the hook at the left, you will be able to remove the Fan Motor Cover. (Fig. 11)

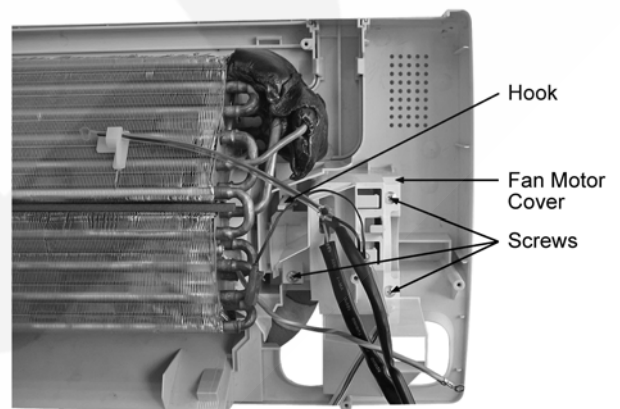

Fig. 11

19. Remove the screw at the Cross Flow fan. (Fig. 12)

Reminders:-

To reinstall the Fan Motor, please adjust the connector location is positioned 45° with Fan Motor before fixing Control Board Cover. (Fig. 12)

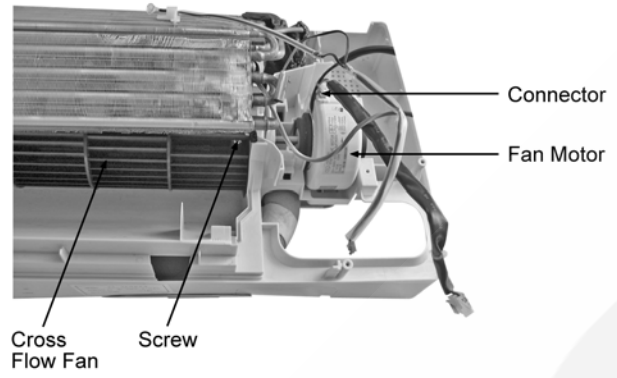

Fig. 12

20. Remove the Bearing. (Fig. 13)

21. Remove the 2 screws at the left of the Evaporator. (Fig. 13)

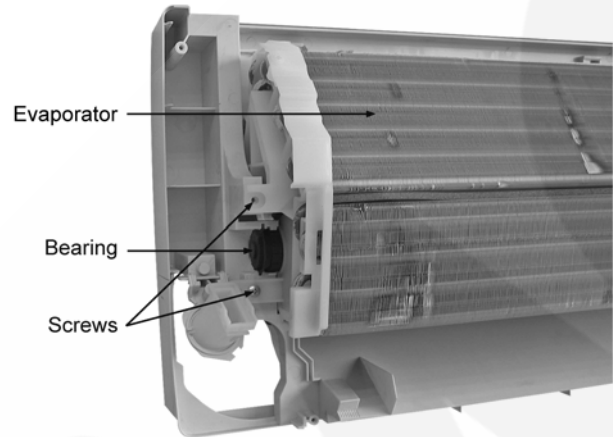

Fig. 13

22. Push up the Evaporator and pull out the Cross Flow Fan from shaft. By then, Fan Motor can be taken out. (Fig. 14)

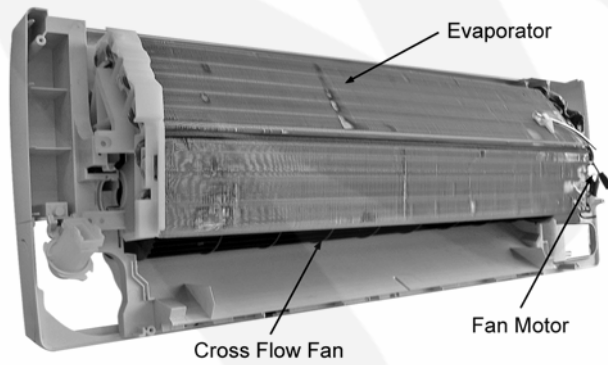
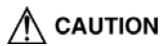

Fig. 14

## 16.2. Filter Cleaning Device Complete Removal Instructions

Tools Required:  
• Screw driver (+ type)  
• Cutter



Switch off the power supply and unplug before cleaning or servicing.

1. Remove the front intake grille.



2. Push to remove top intake grille.  
3. Release 2 caps and unscrew.  
4. Unscrew and then remove the particular piece (right).

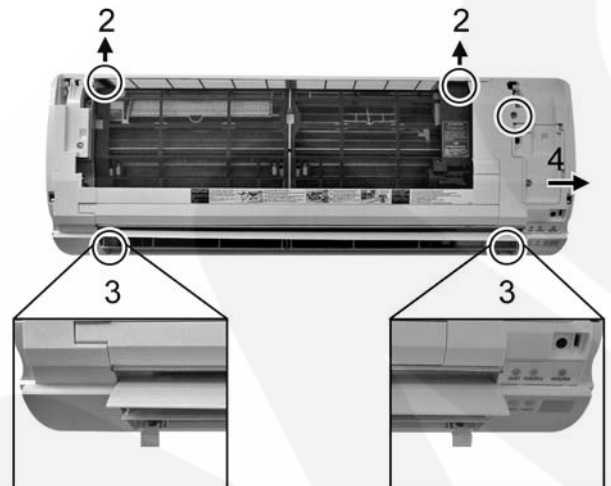

5. Unscrew and remove the particular pieces (left and bottom).  
**Caution: The particular piece (bottom) may drop out while removing.**

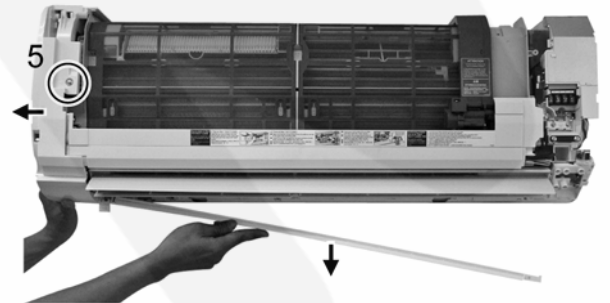

6. Remove terminal cover.  
7. Cut the cable tie.

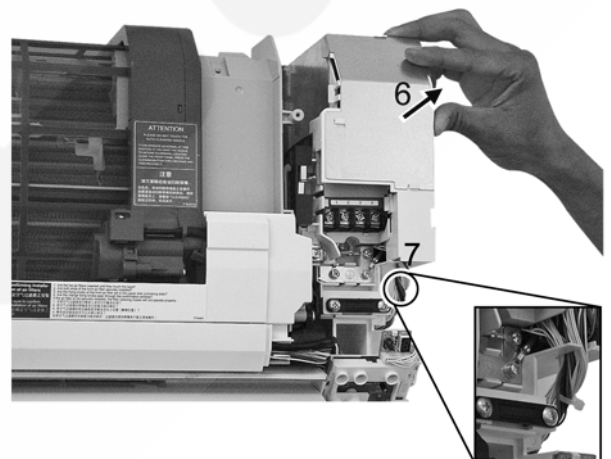

8. Remove all connectors from the PCB.

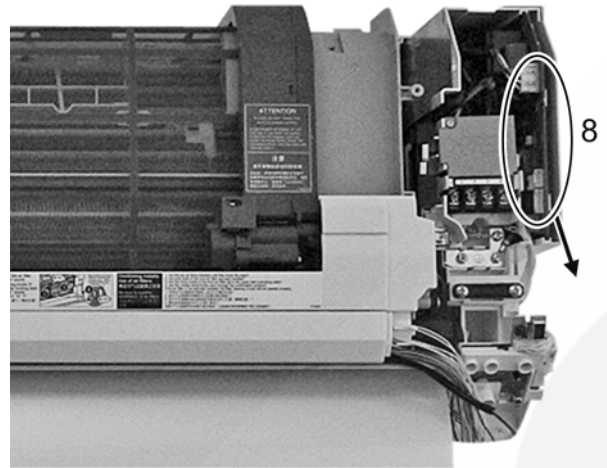

9. Remove screws (5 pieces).

10. Lift the filter cleaning device gently to remove.

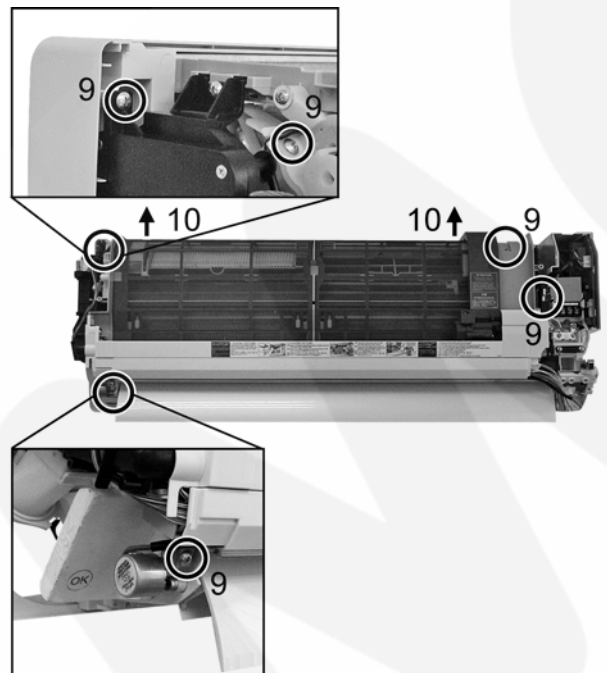

## 16.3. Ventilation Device Removal Instructions

1. Cut the cable tie and remove the flexible hose connector.
2. Unscrew (1 piece).

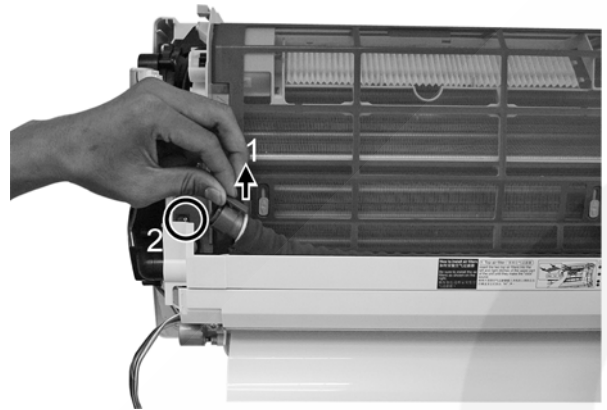

3. Disconnect the connector.
4. Unscrew (2 pieces).

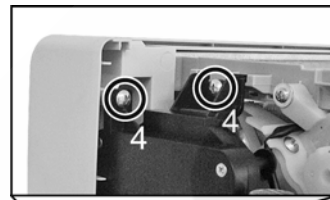

5. Disconnect the ventilation device from the duct.
6. Remove the ventilation device.

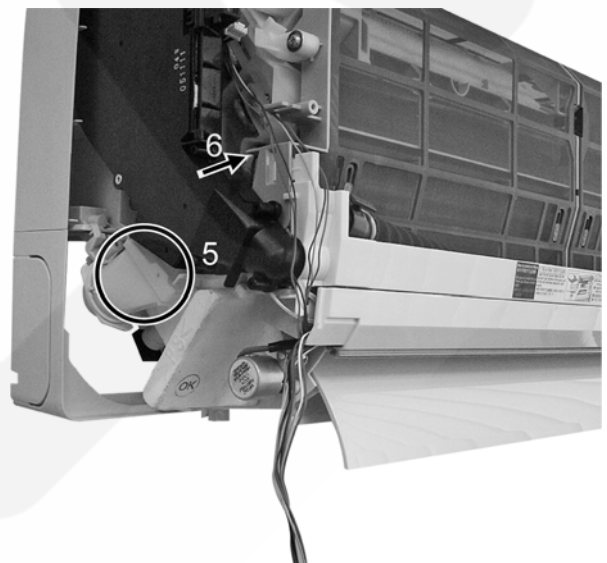

## 16.4. Gear Removal Instructions

1. Unscrew (3 pieces).



2. Remove the gear.

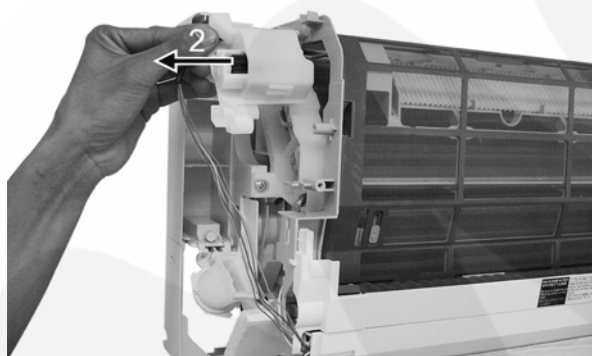

3. Disconnect the connector from the gear.





## 16.5. Outdoor Propeller Fan and Fan Motor

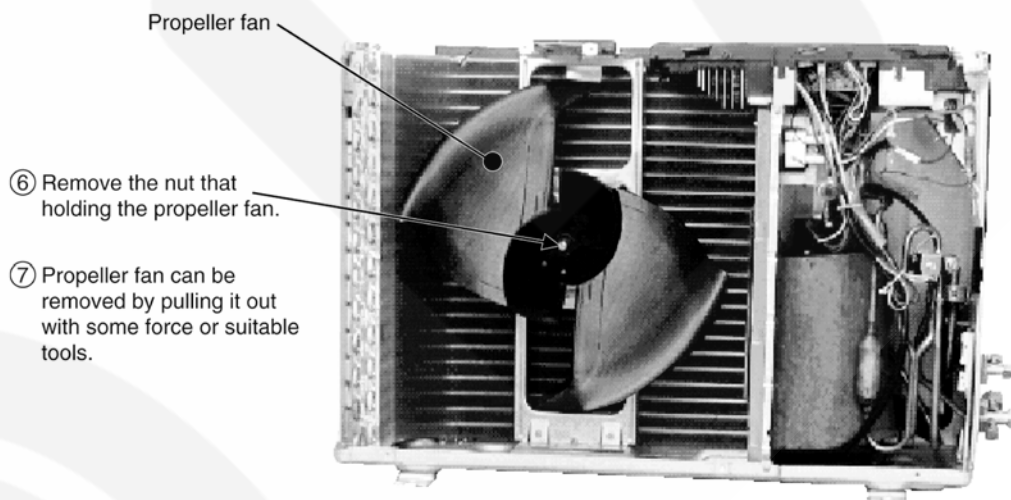
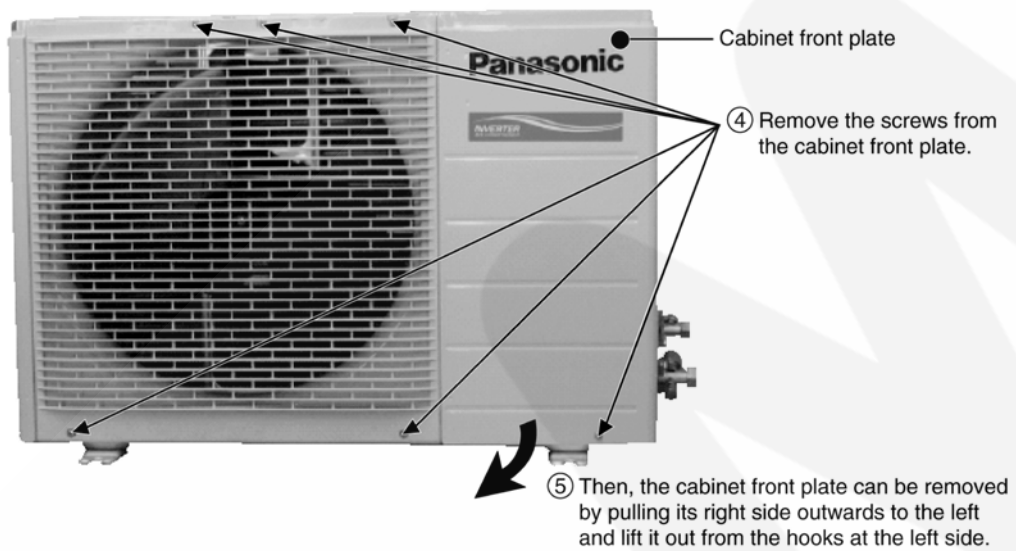
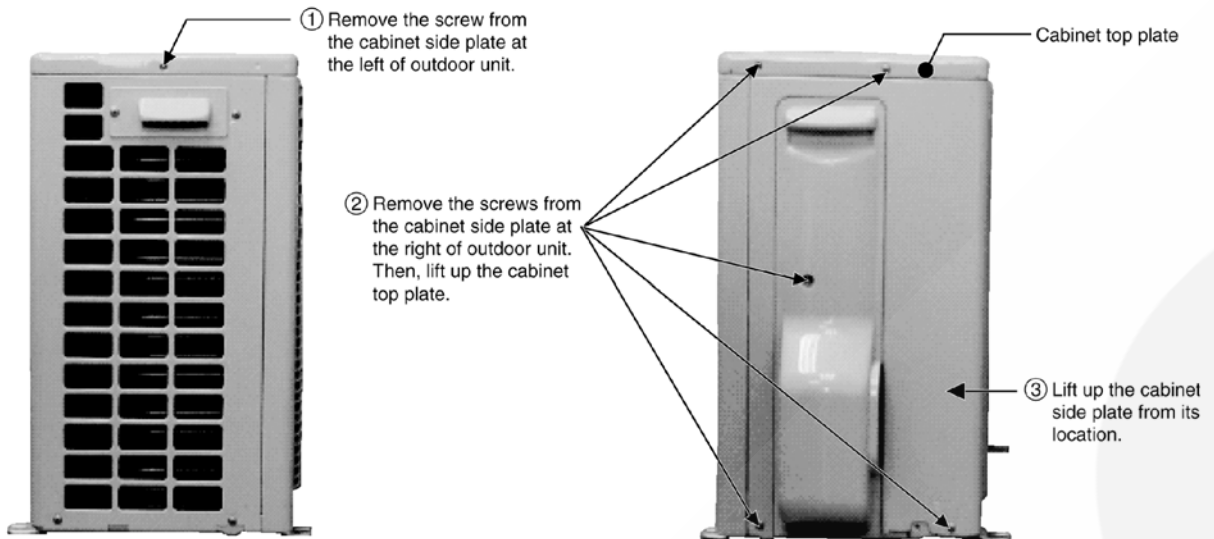

⑧ Remove 4 screws holding the fan motor. Release the connector of fan motor from outdoor electronic controller and the fan motor can be removed from its location.

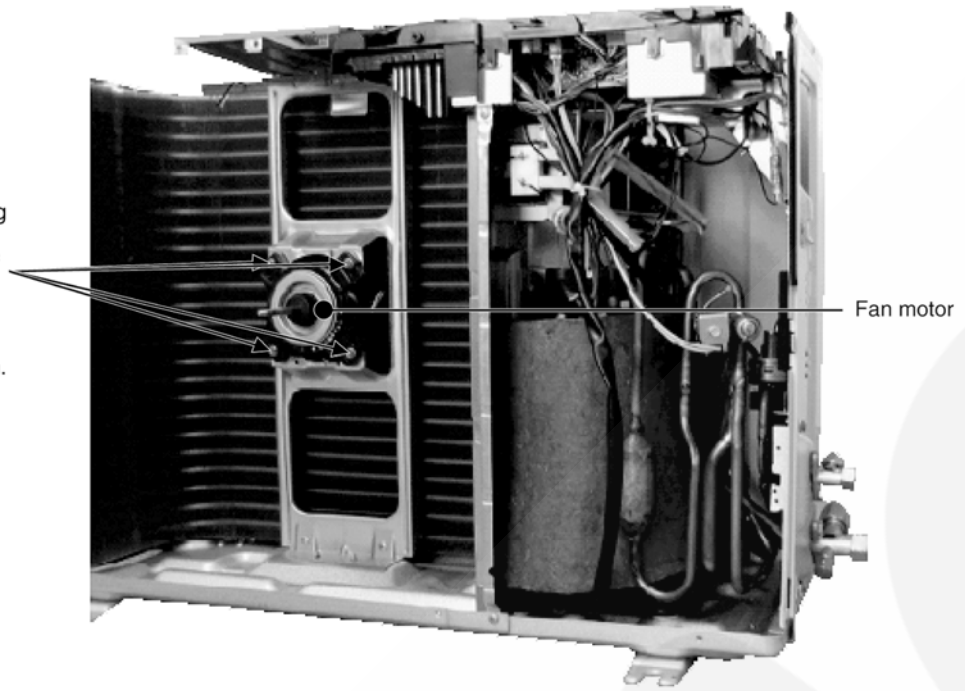

# 17 Technical Data

## 17.1. CS-XE9EKE CU-XE9EKE

### A. Cool: Outdoor Temperature Change

Indoor Temp.: 27/19°C

Remote Con.: HI FAN, COOL 16°C

Comp. Hz: Rated Cooling

Voltage: 230 V

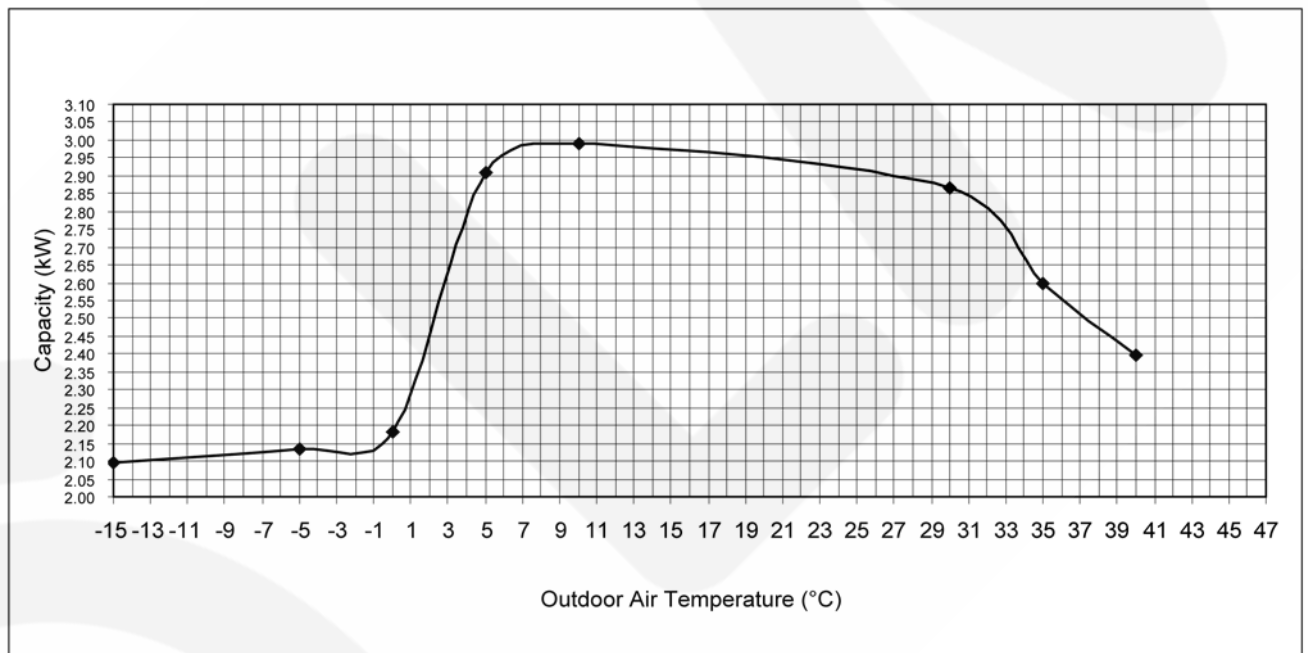
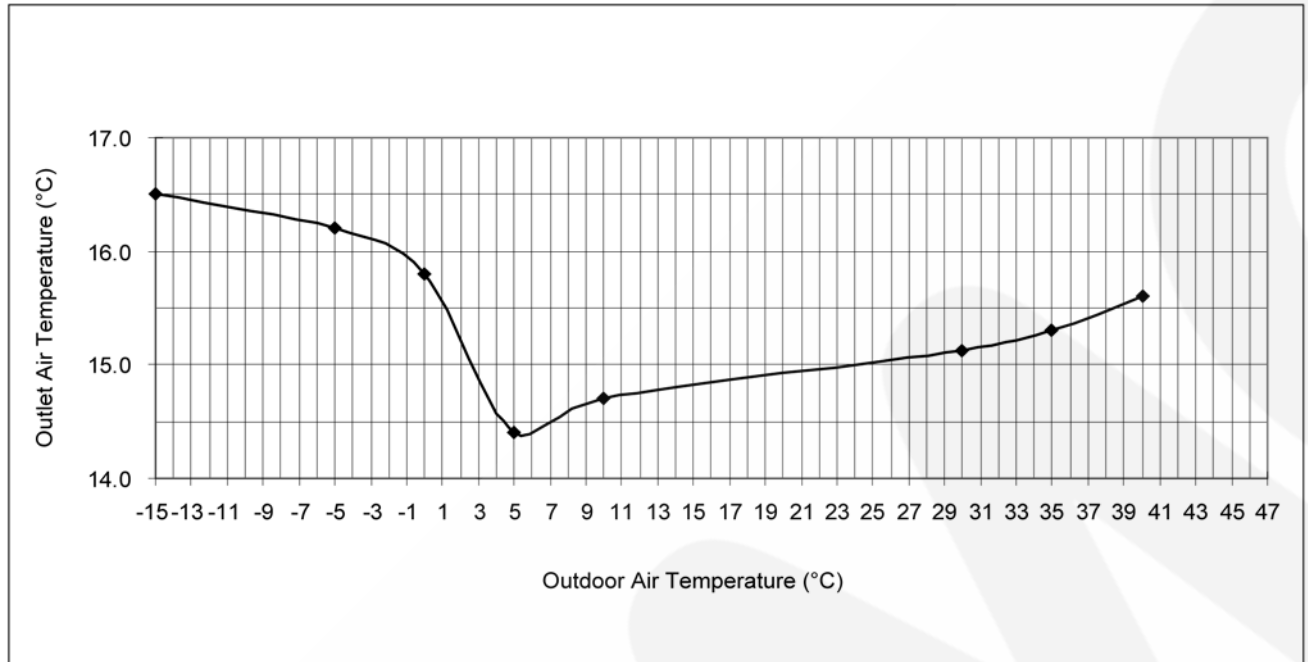

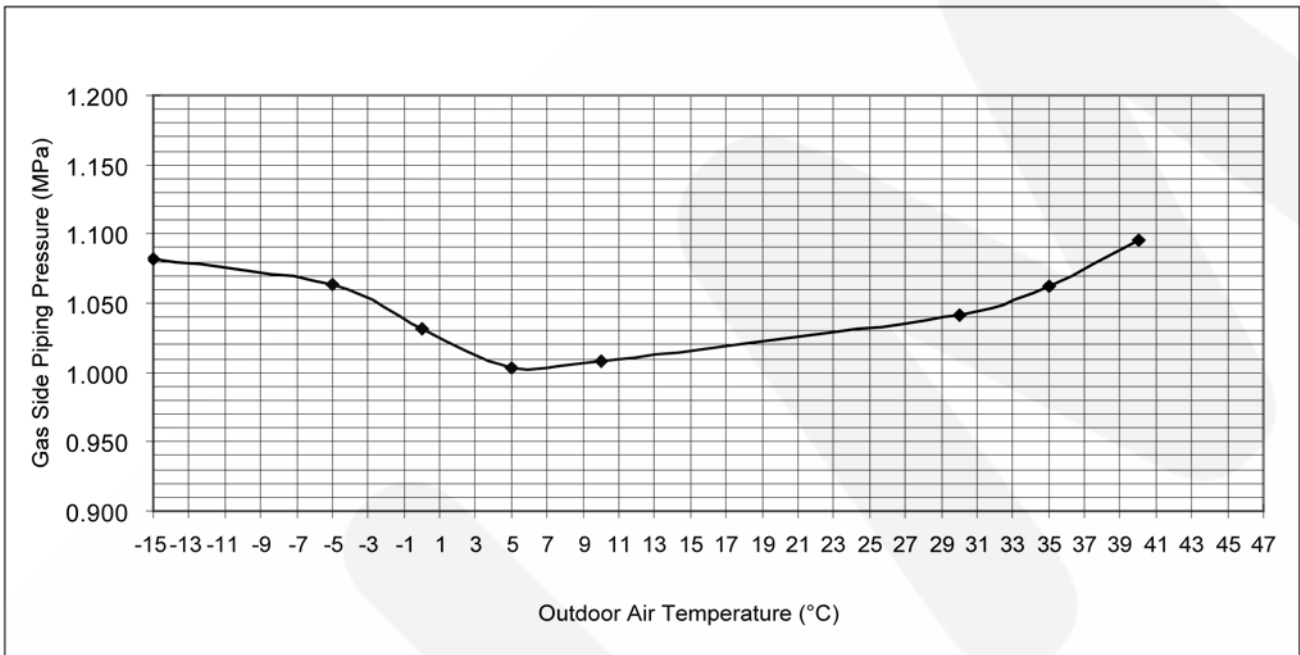
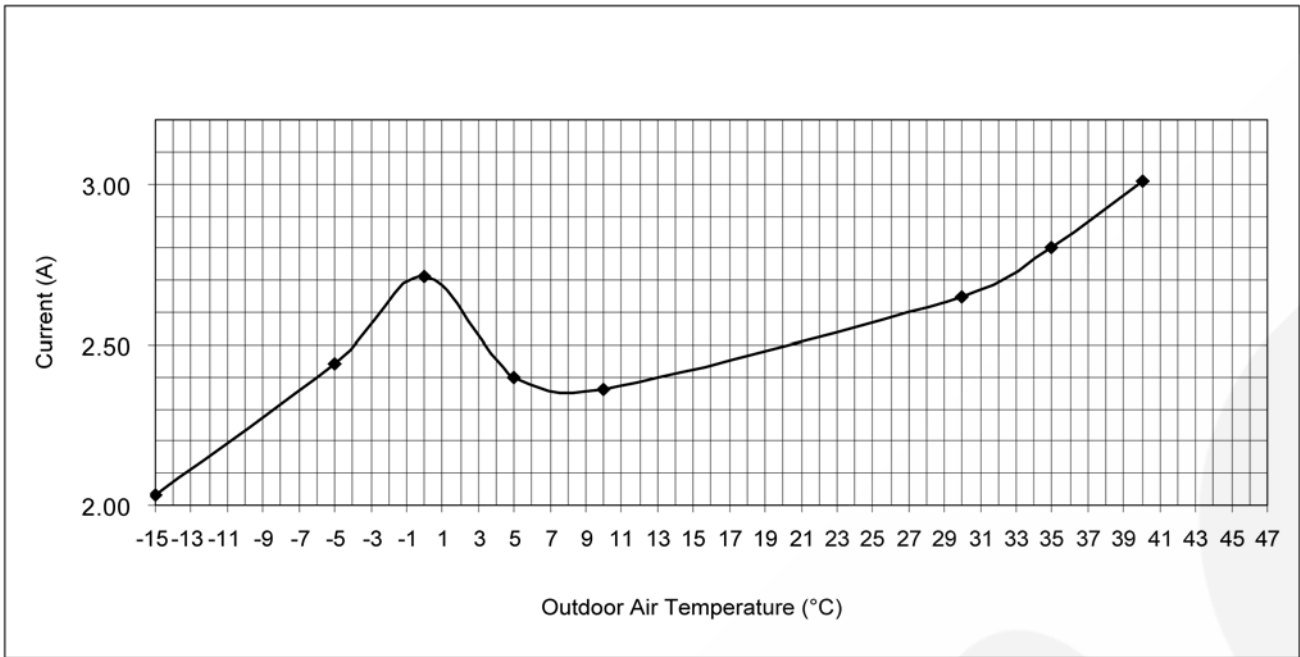

**B. Cool: Pipe Length Change**

Indoor Temp.: 27/19°C, 35/-°C

Remote Con.: HI FAN, COOL 16°C

Comp. Hz: Rated Cooling

Voltage: 230 V

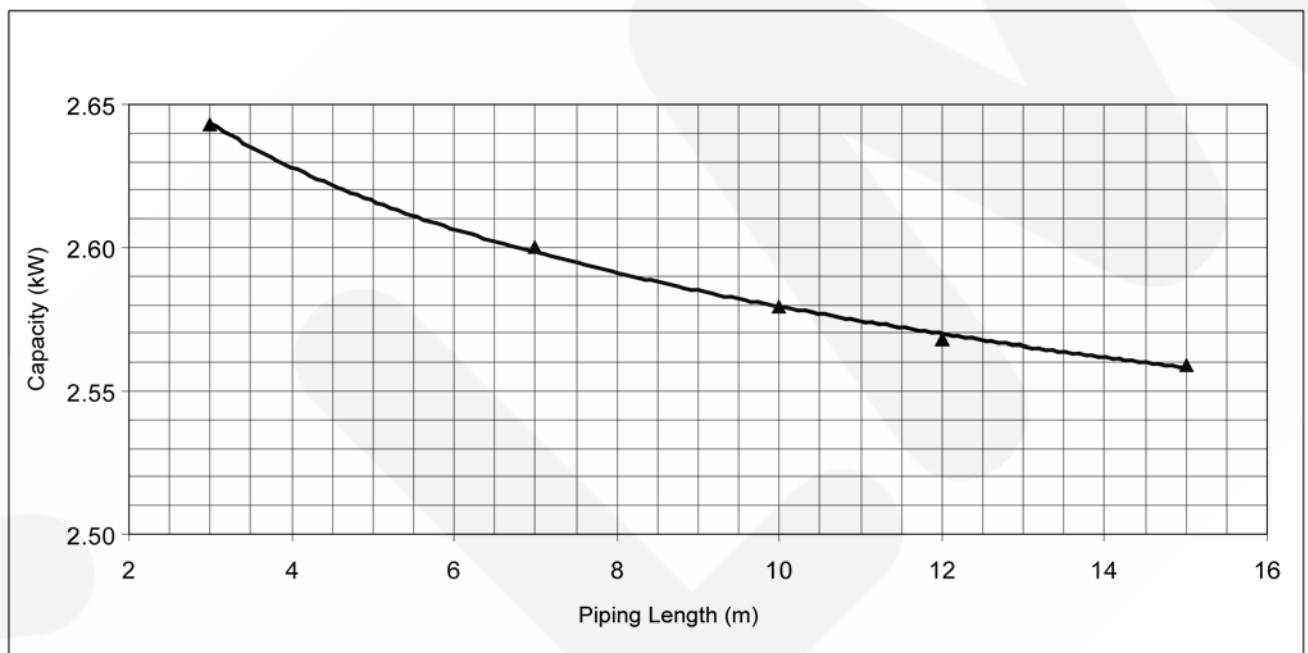
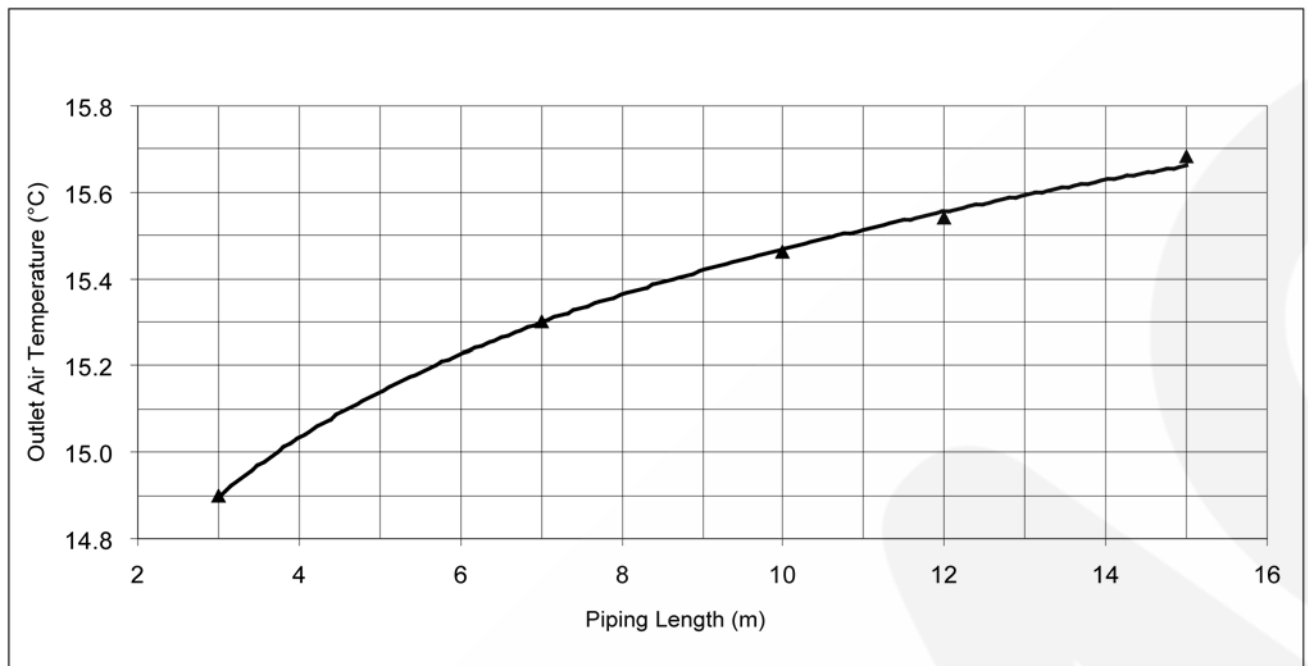

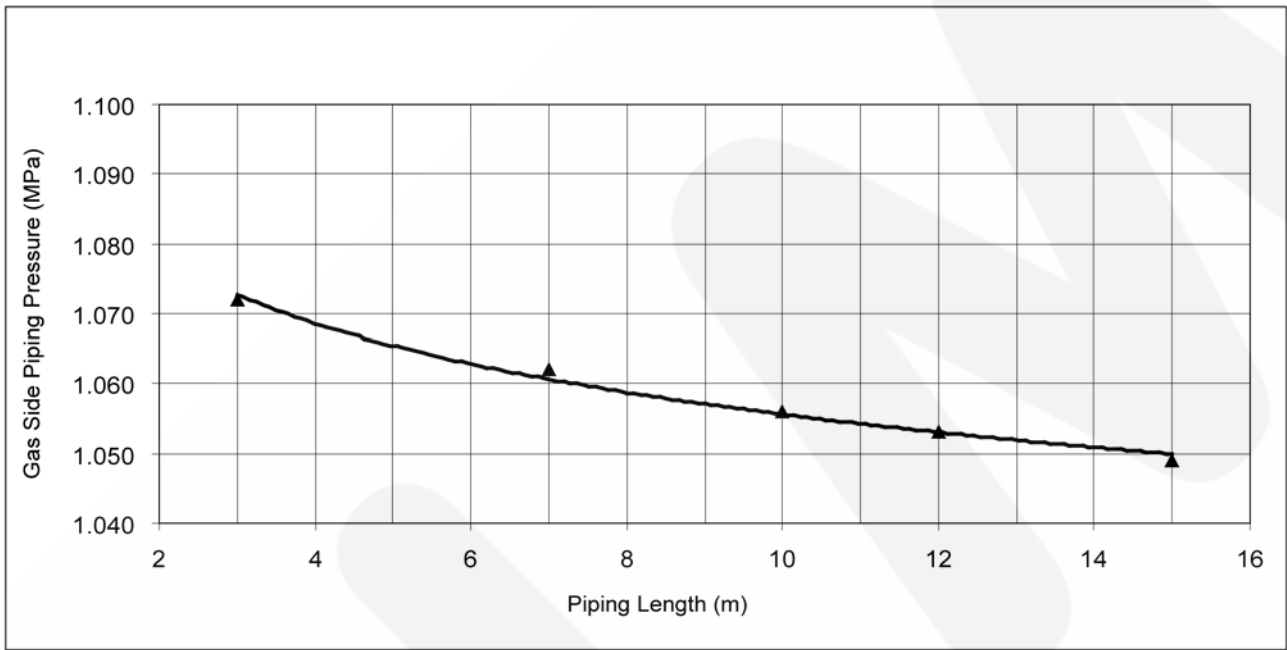
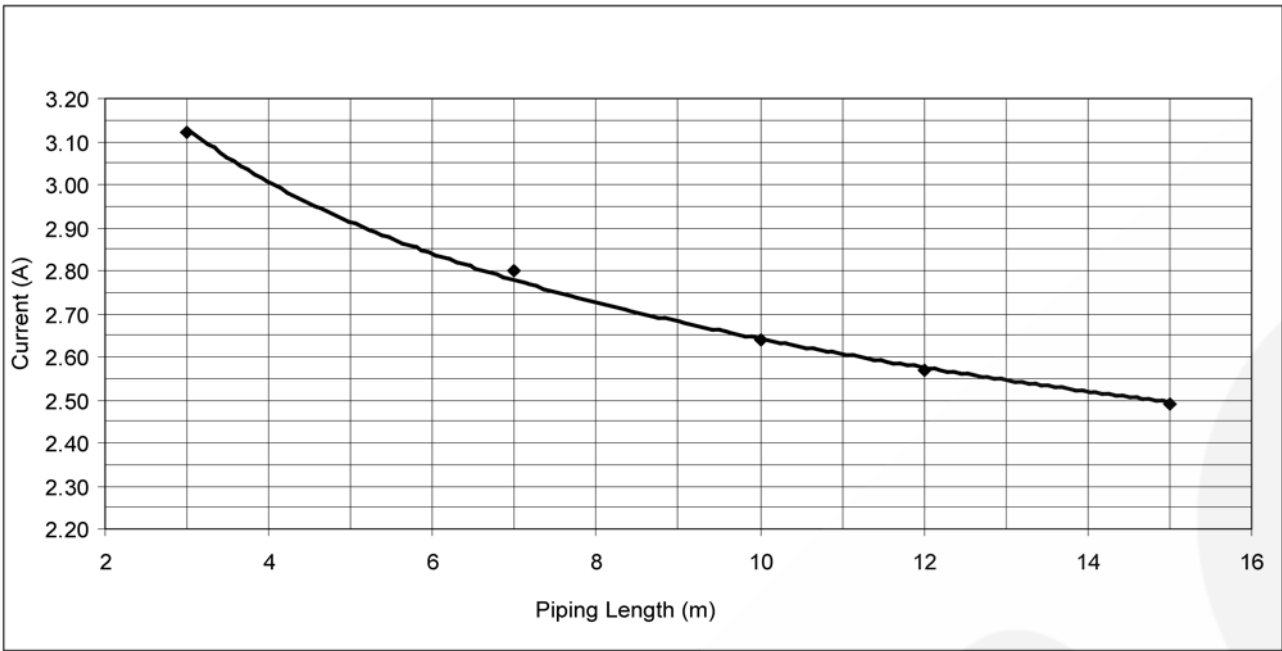

**C. Heat: Outdoor Temperature Change**

Indoor Temp.: 20/-°C

Remote Con.: HI FAN, HEAT 30°C

Comp. Hz: Rated Heating

Voltage: 230 V

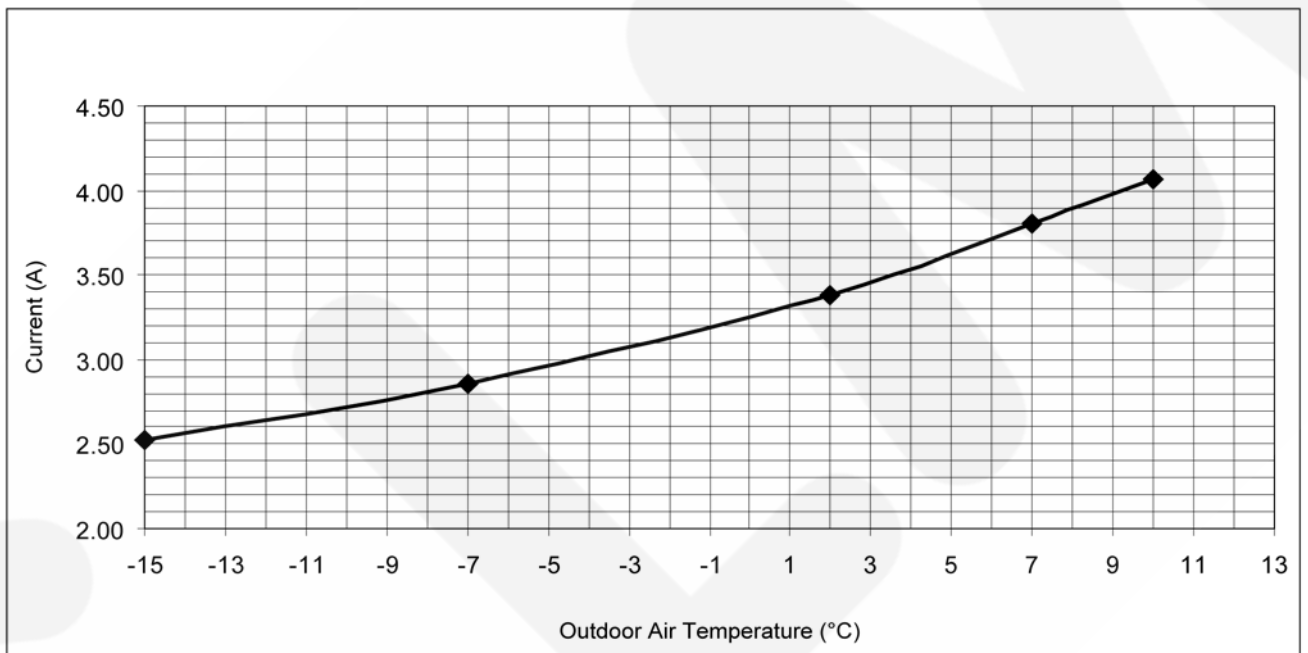
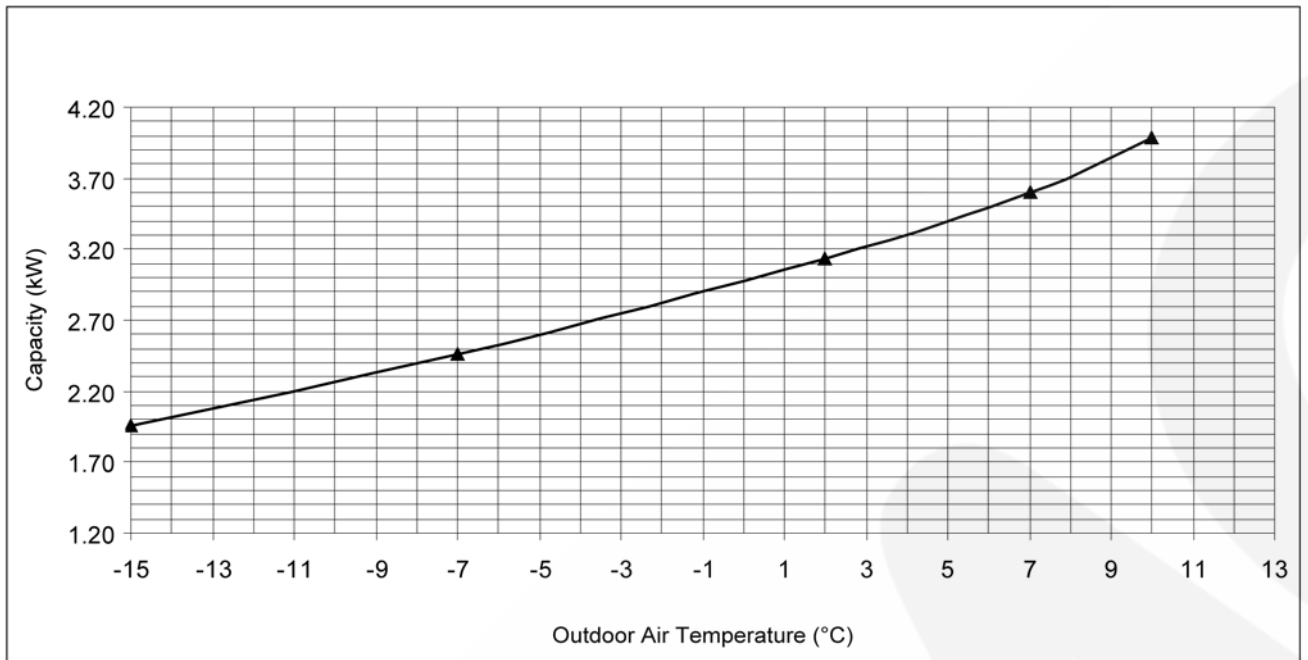

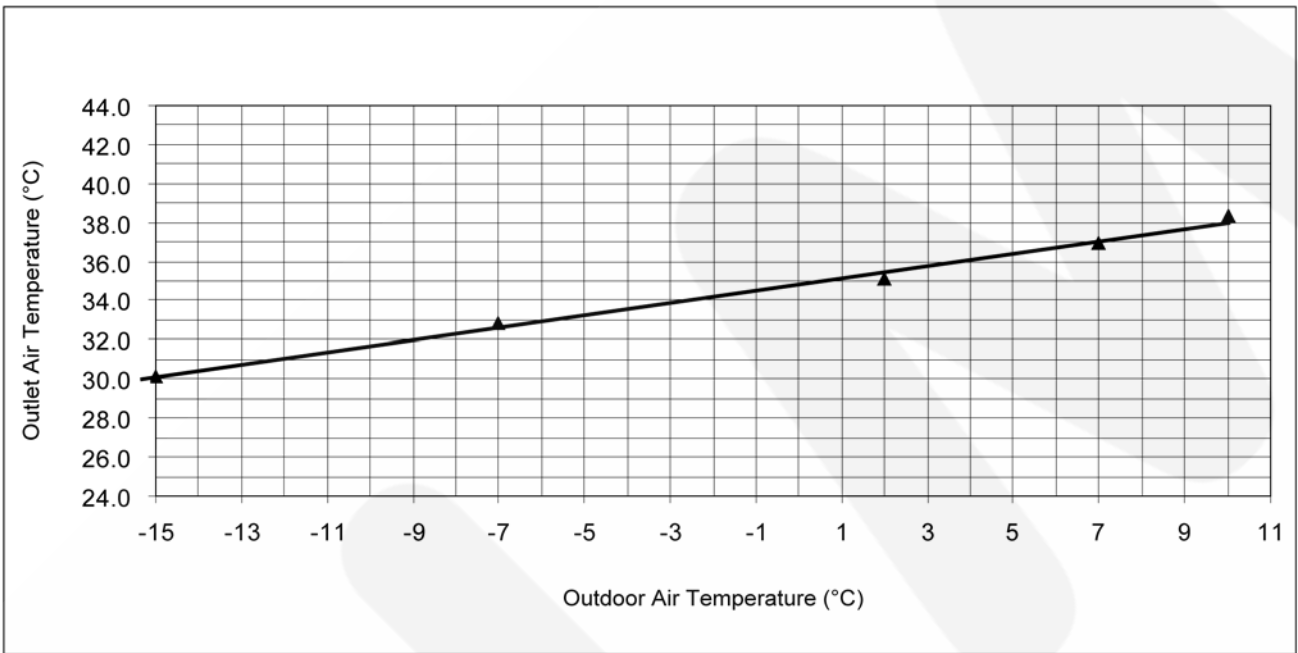
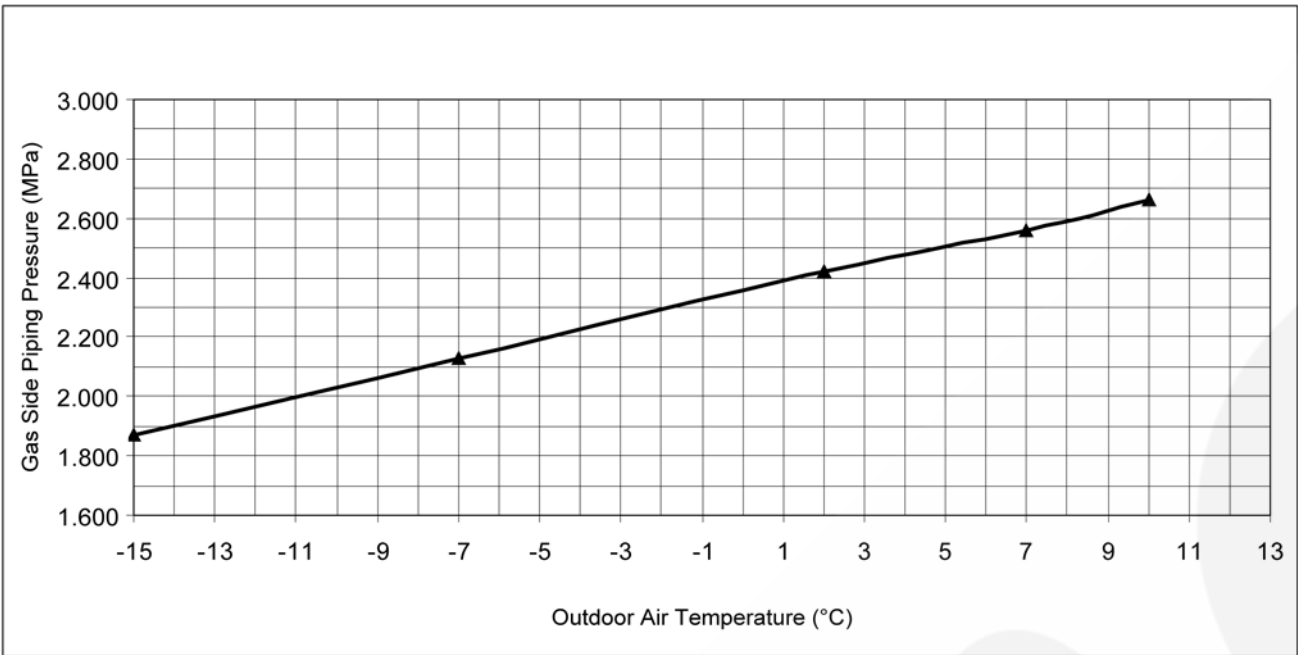



**D. Heat: Pipe Length Change**

Indoor Temp.: 20/-°C, 7/6°C

Remote Con.: HI FAN, HEAT 30°C

Comp. Hz: Rated Heating

Voltage: 230 V

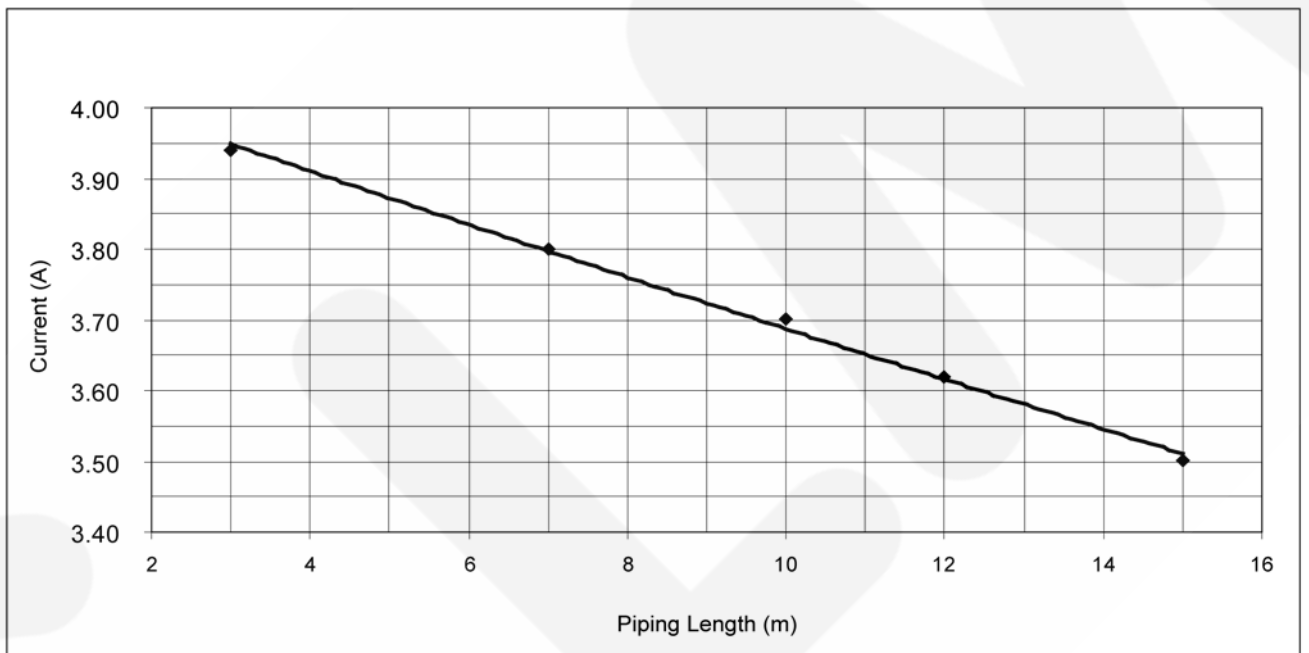
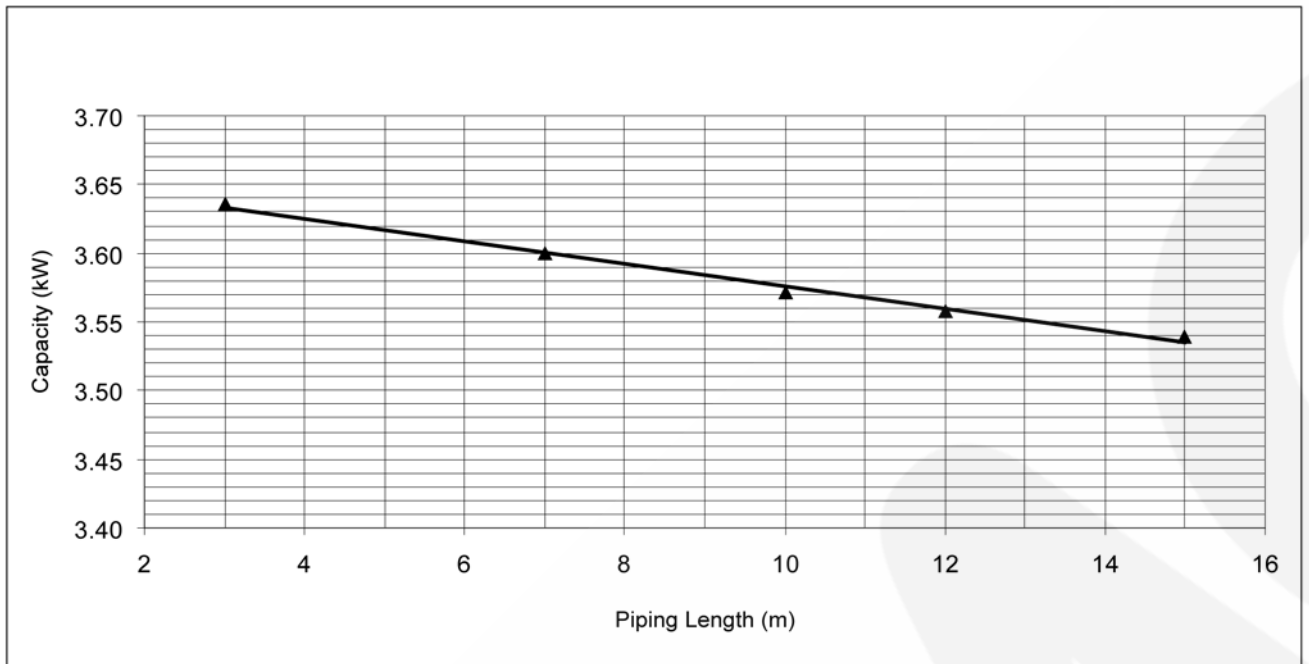

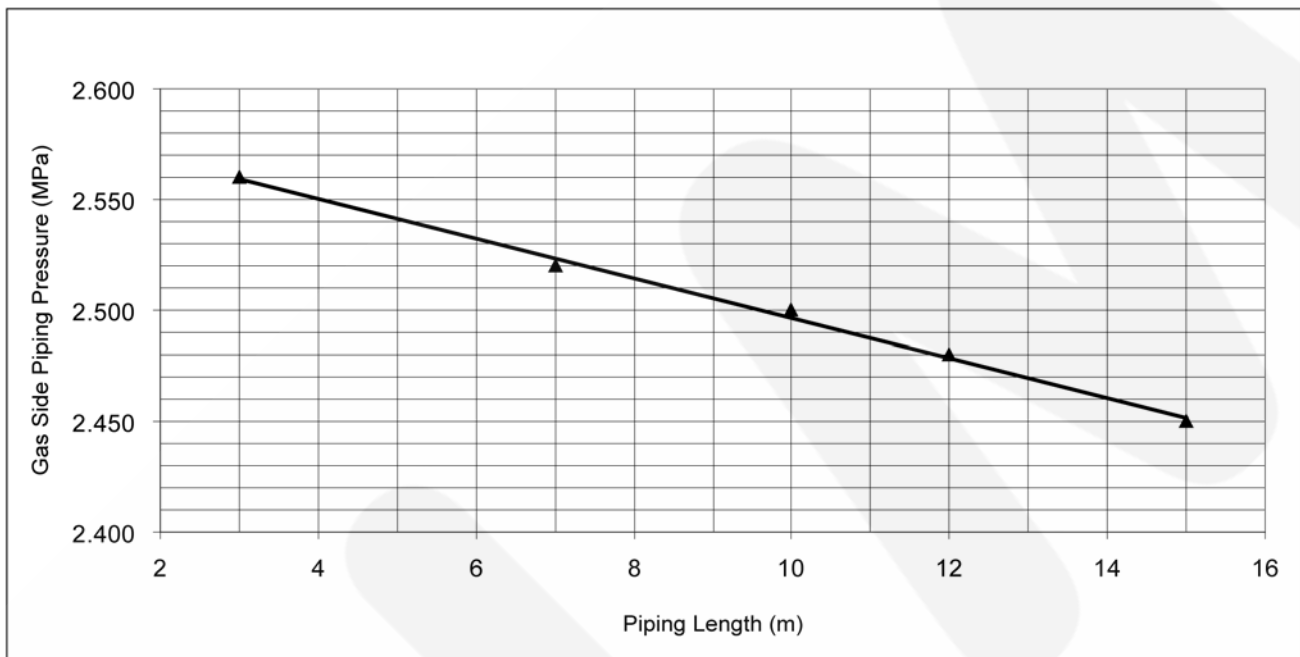
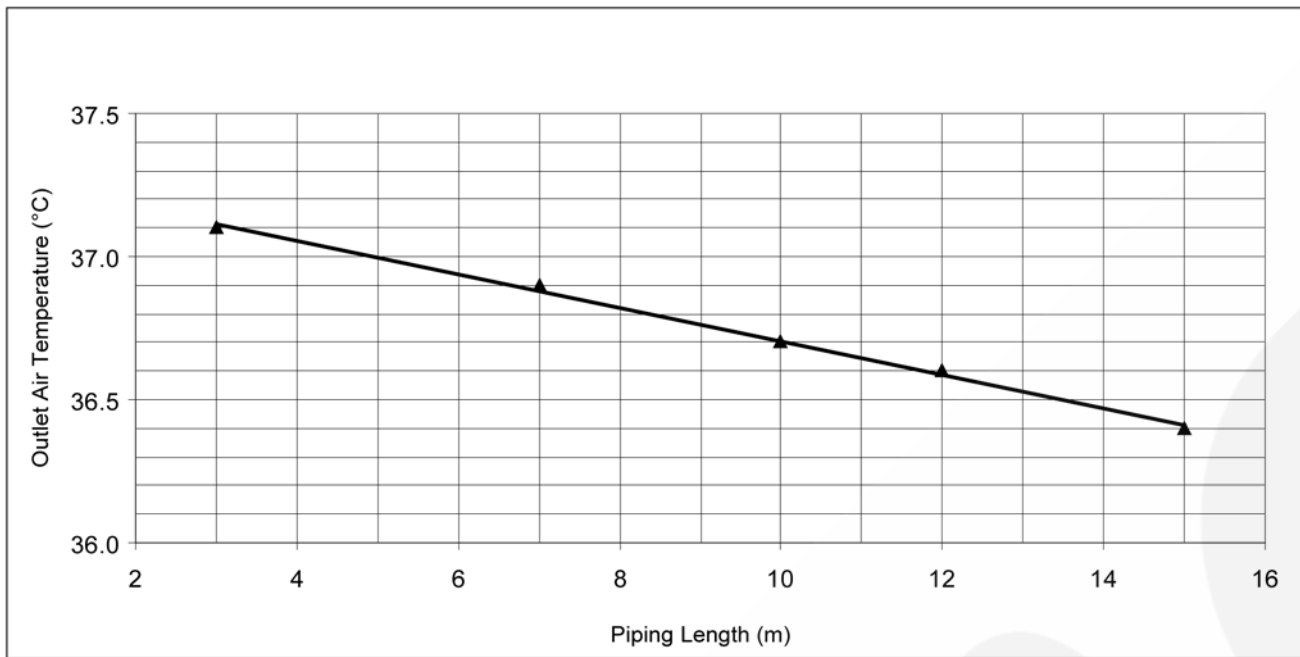

## 17.2. CS-XE12EKE CU-XE12EKE

### A. Cool: Outdoor Temperature Change

Indoor Temp.: 27/19°C

Remote Con.: HI FAN, COOL 16°C

Comp. Hz: Rated Cooling

Voltage: 230 V

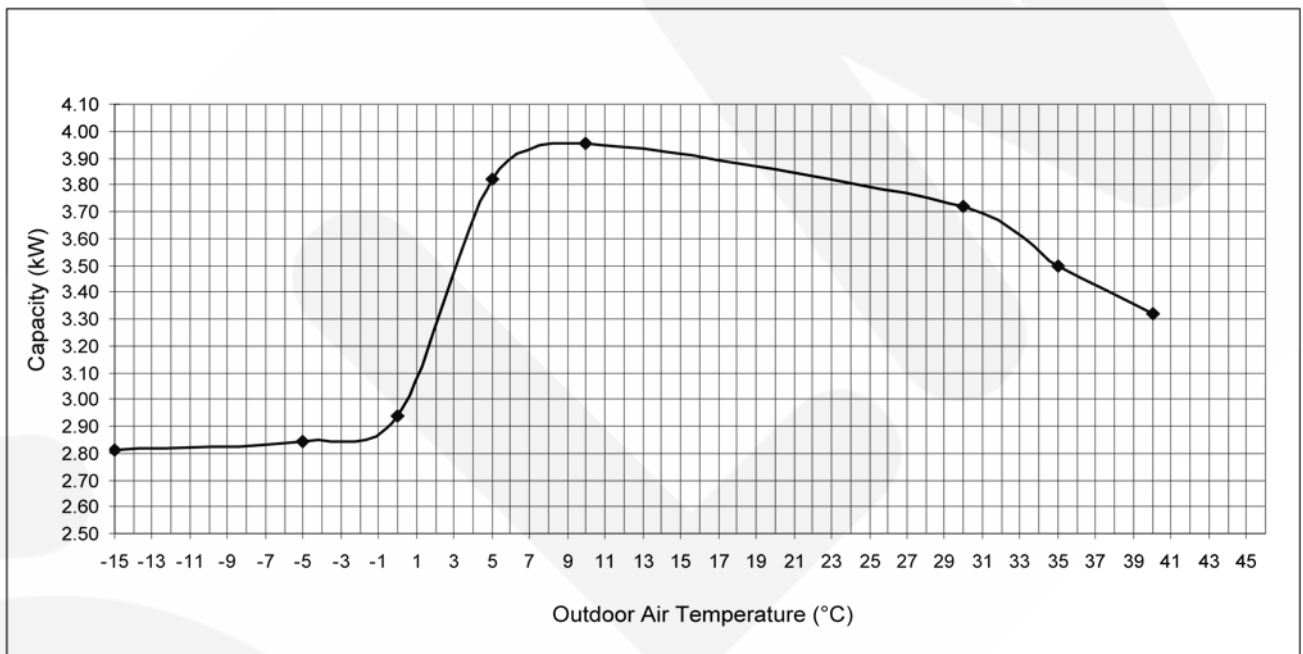
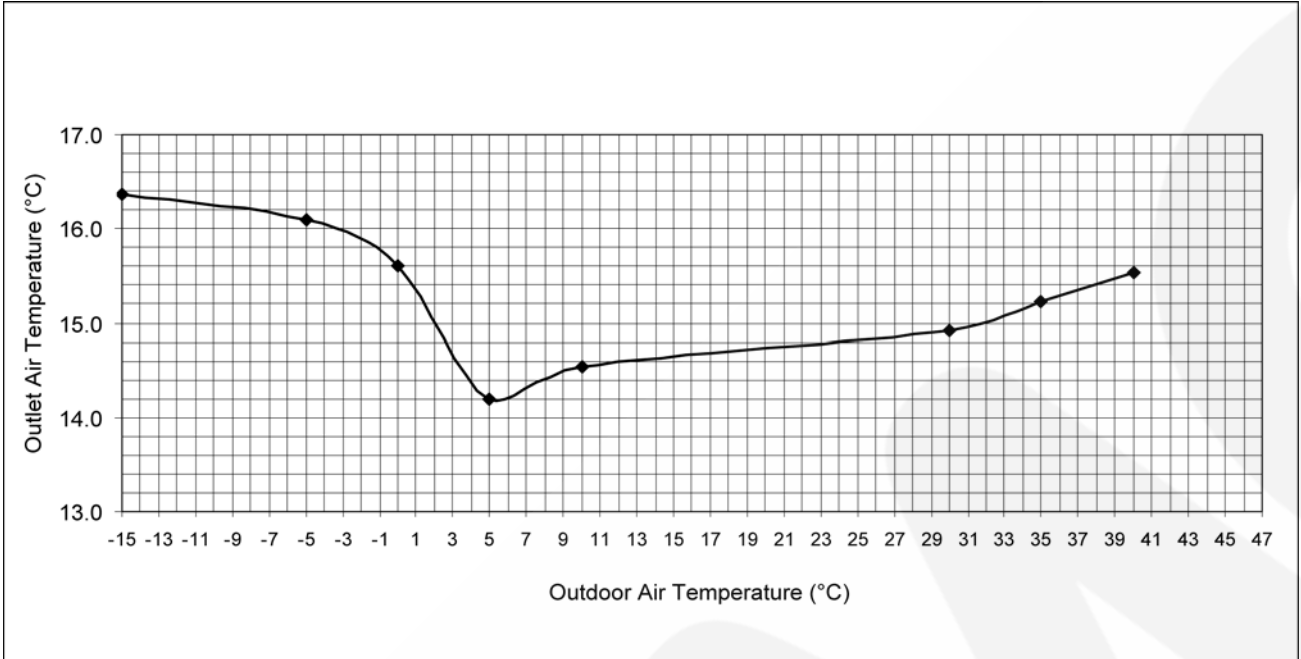

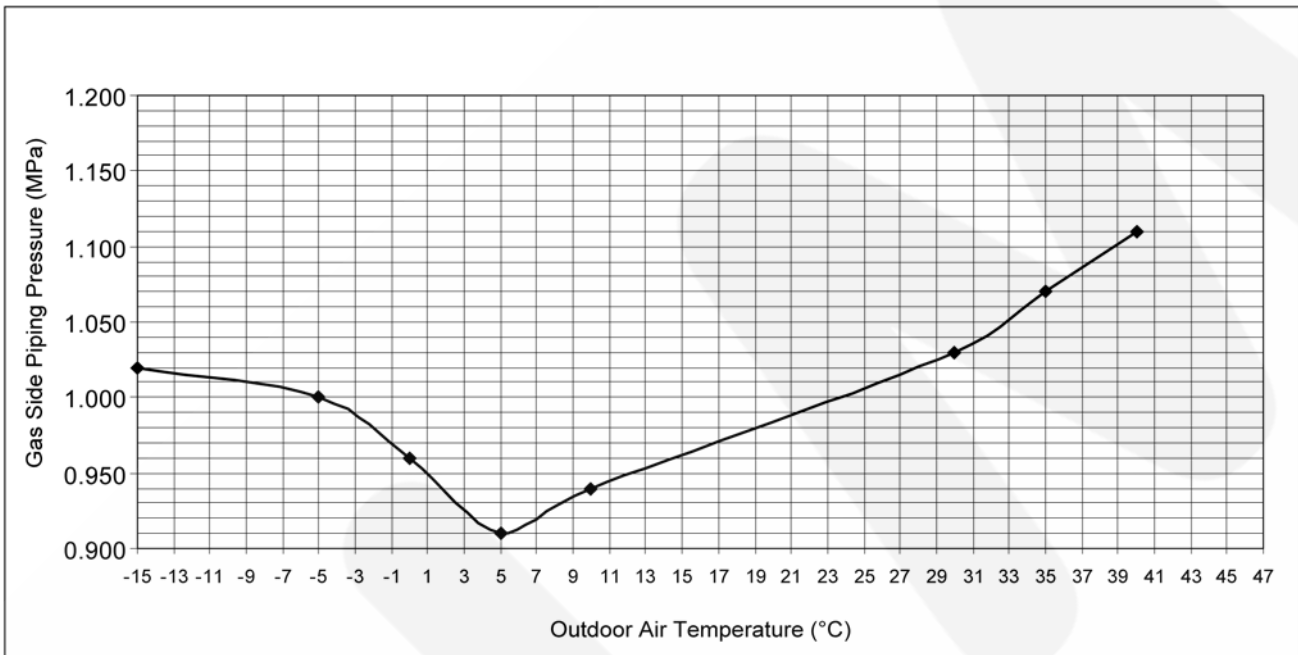
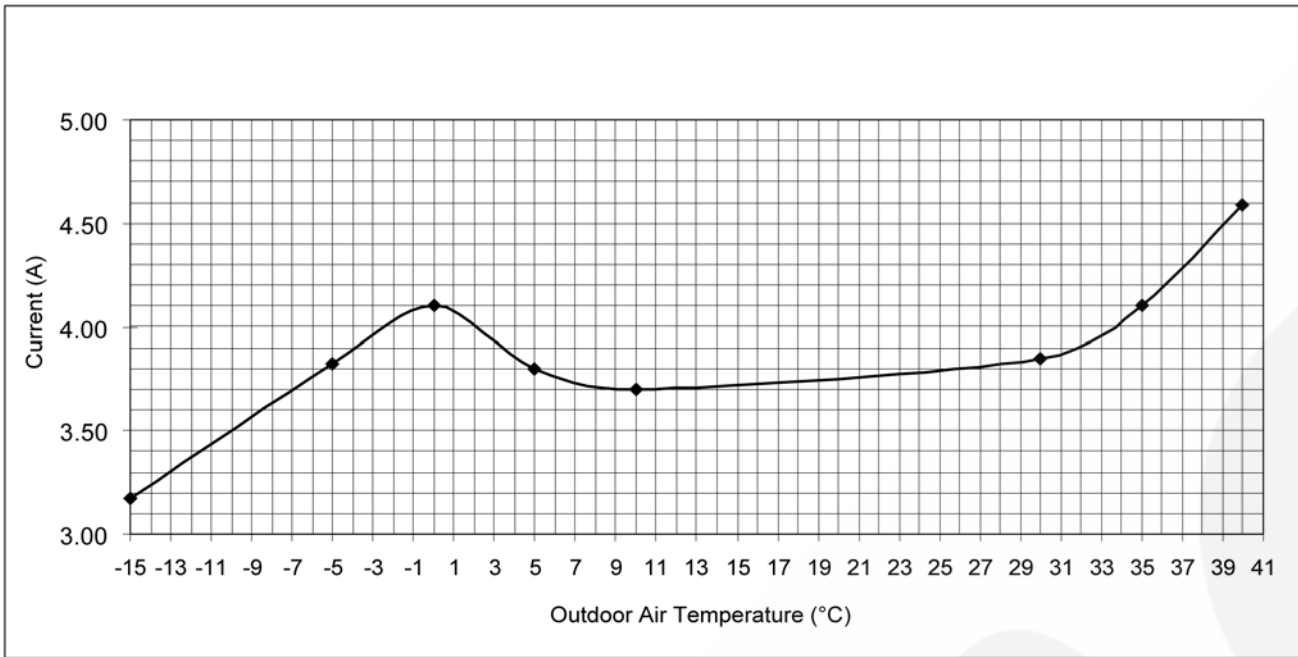

**B. Cool: Pipe Length Change**

Indoor Temp.: 27/19°C, 35/-°C

Remote Con.: HI FAN, COOL 16°C

Comp. Hz: Rated Cooling

Voltage: 230 V

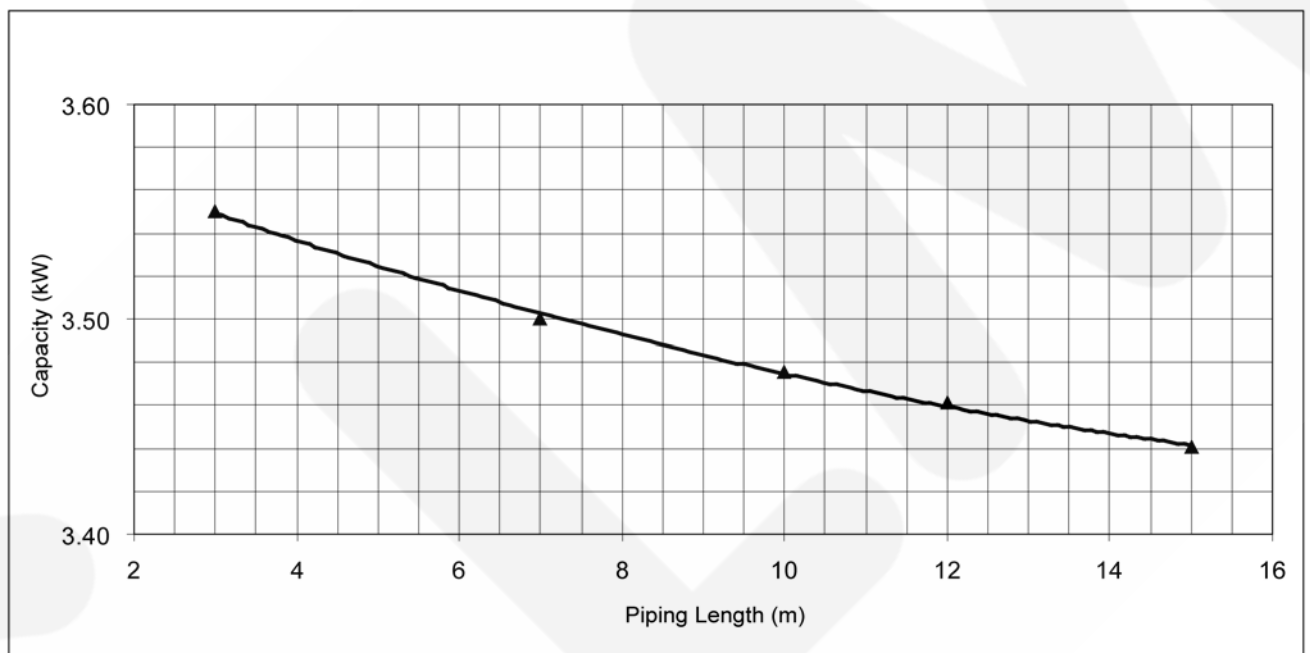
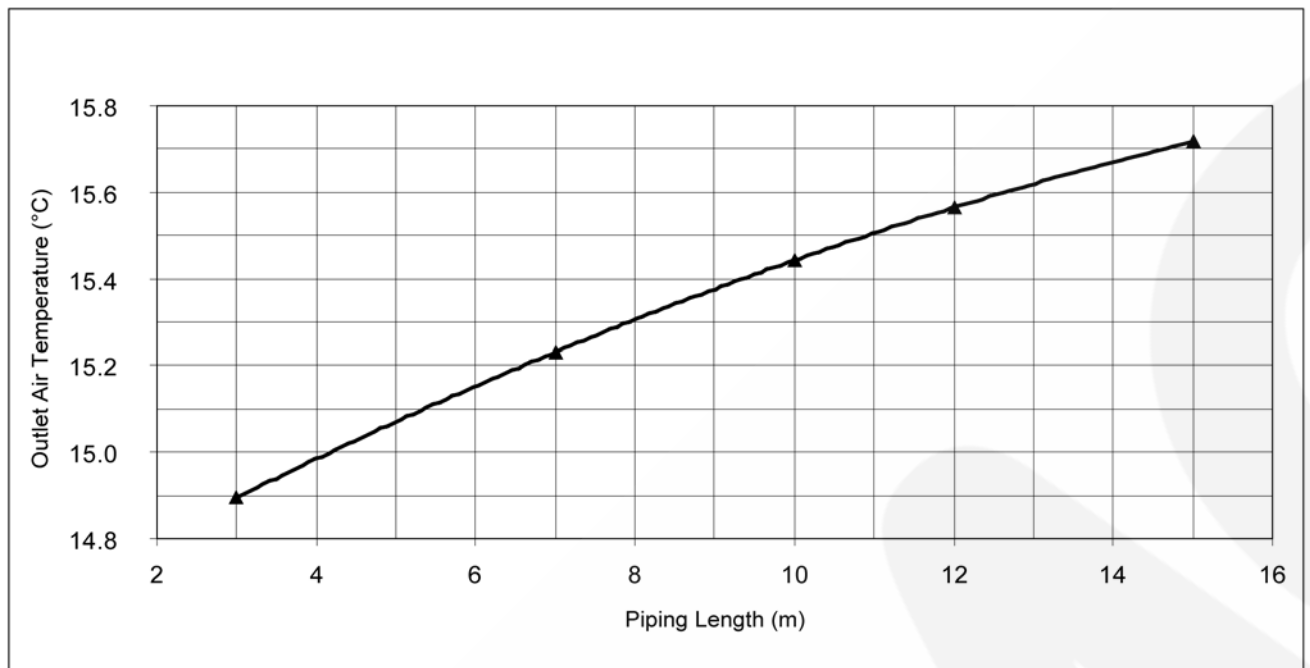

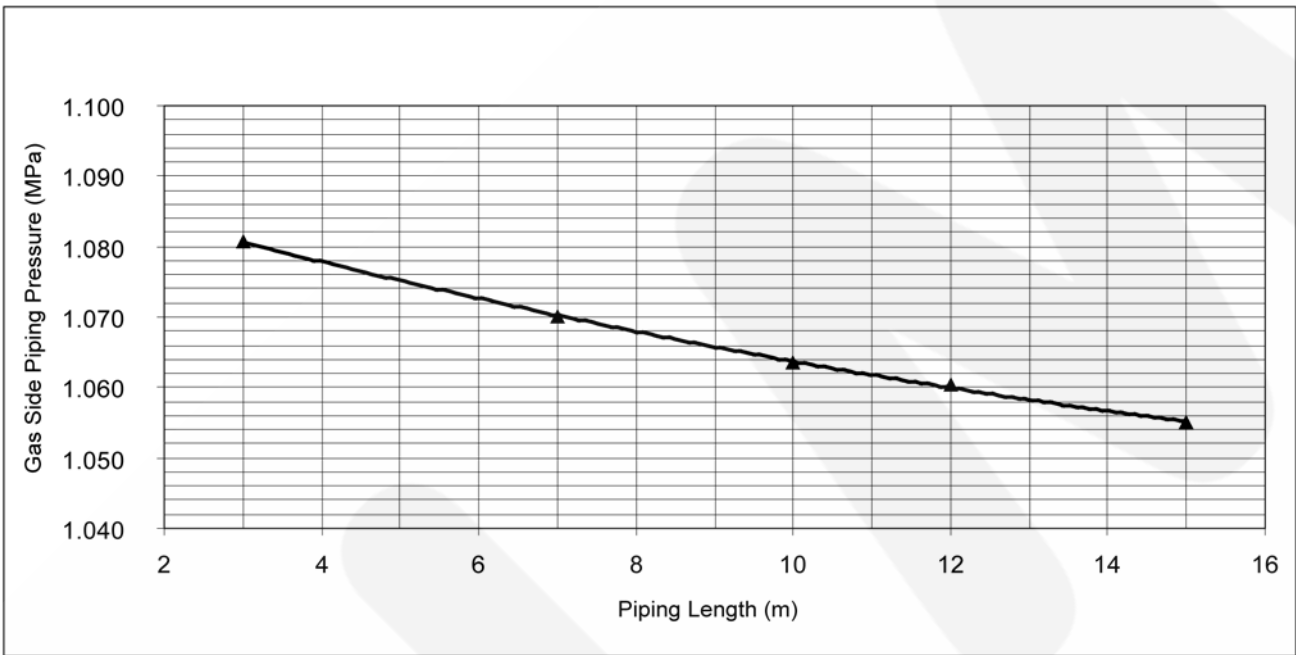
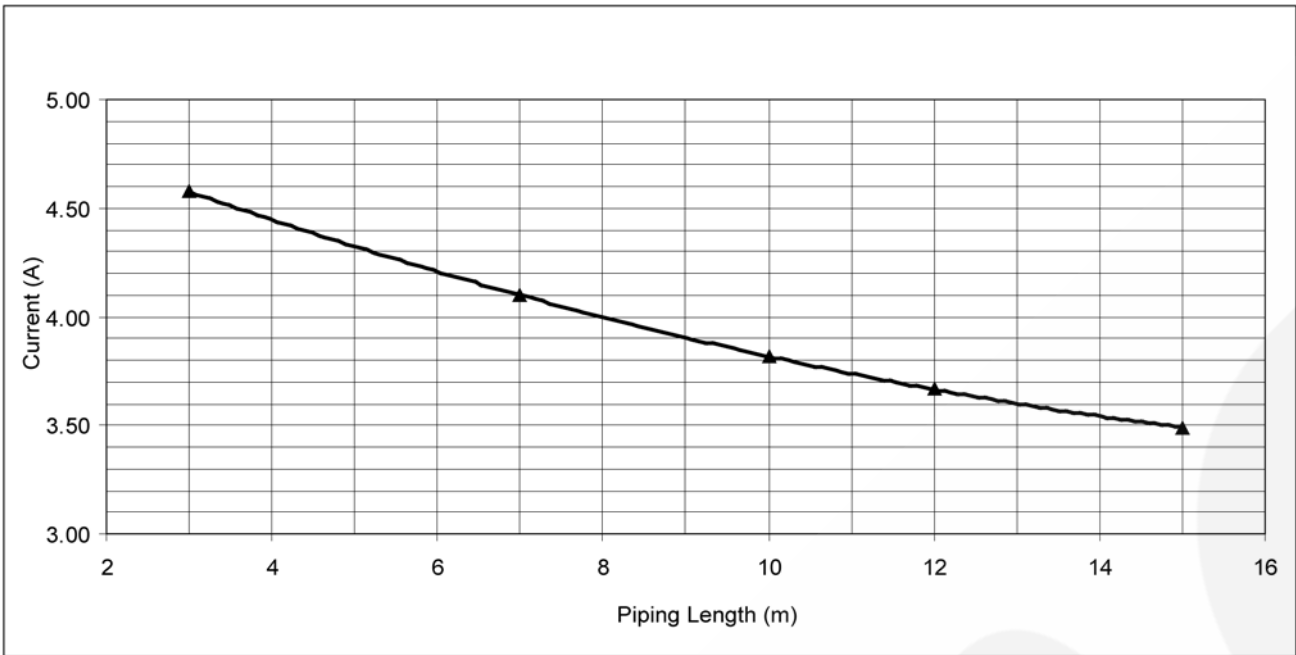

**C. Heat: Outdoor Temperature Change**

Indoor Temp.: 20/-°C

Remote Con.: HI FAN, HEAT 30°C

Comp. Hz: Rated Heating

Voltage: 230 V

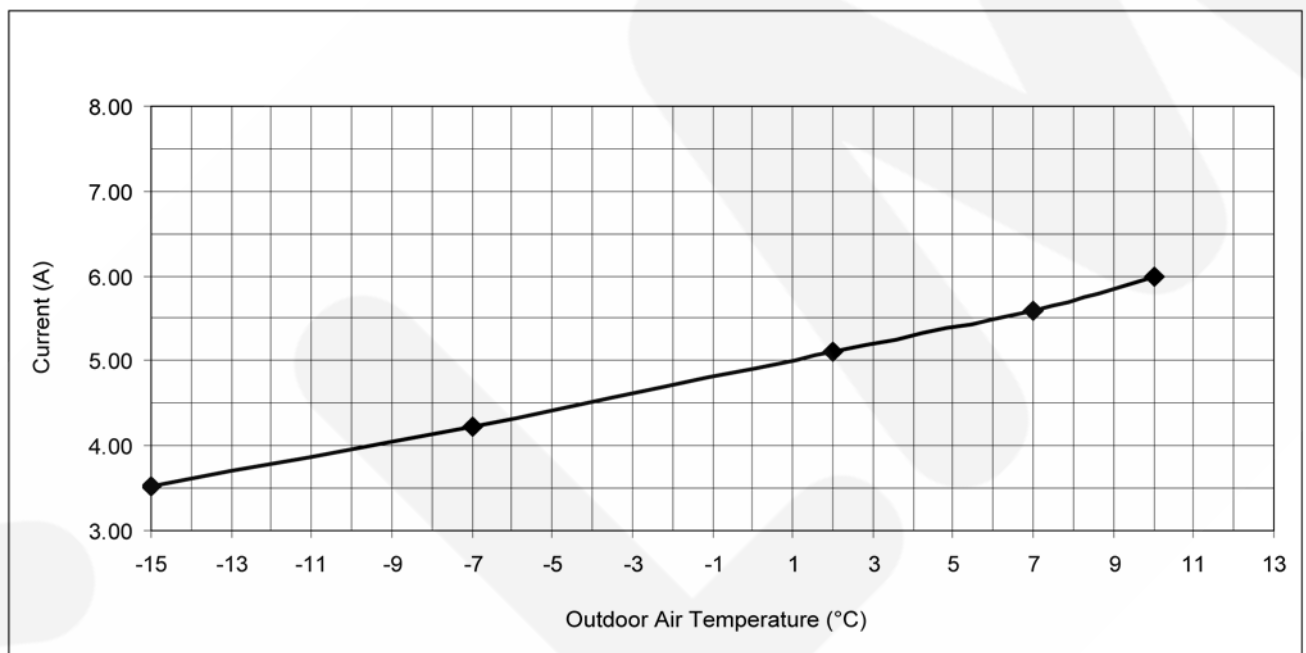
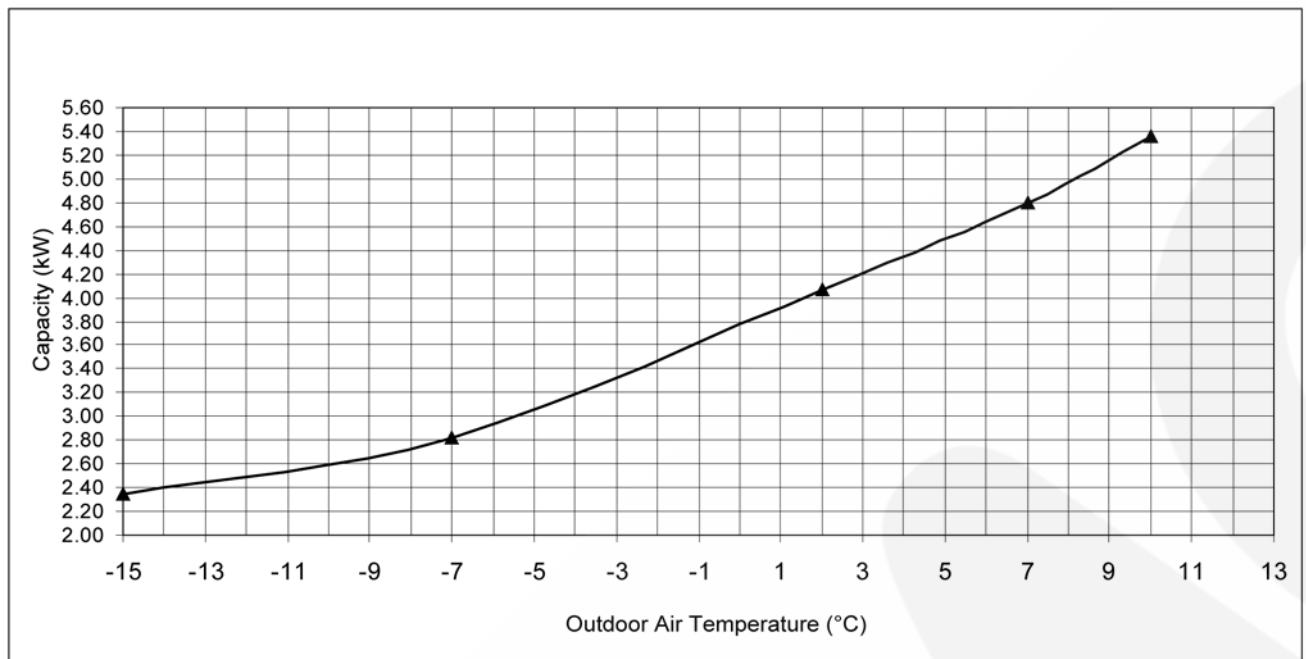

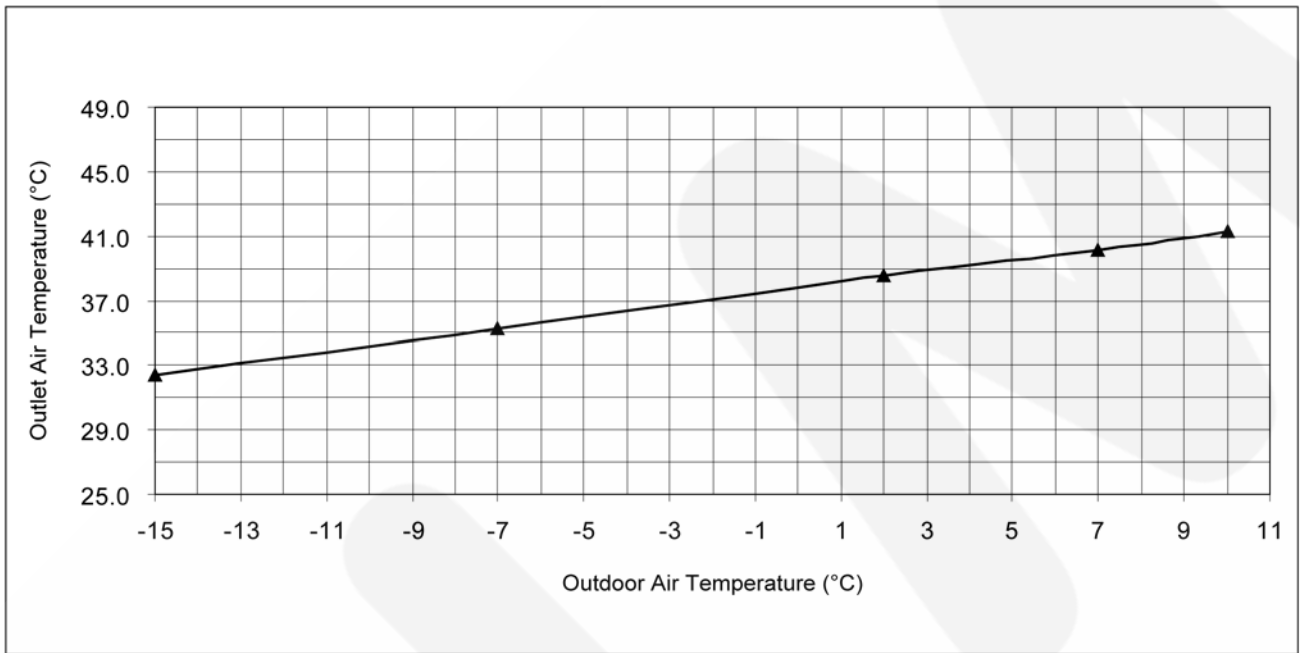
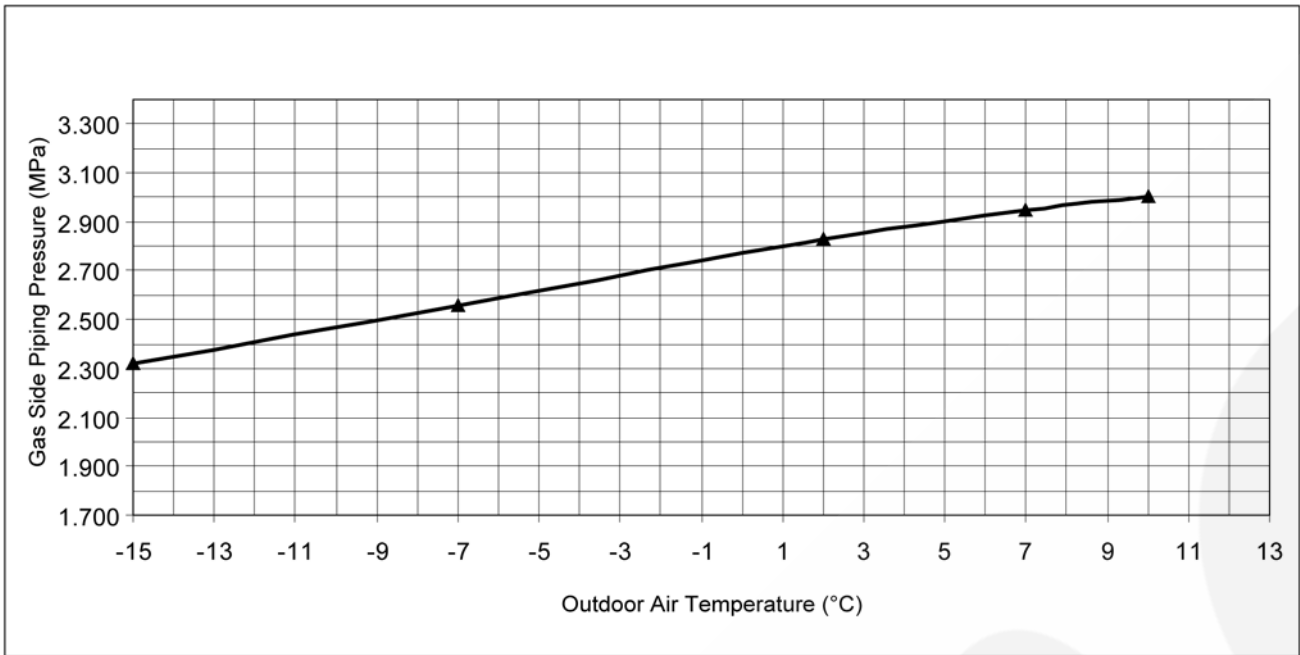



**D. Heat: Pipe Length Change**

Indoor Temp.: 20/-°C, 7/6°C

Remote Con.: HI FAN, HEAT 30°C

Comp. Hz: Rated Heating

Voltage: 230 V

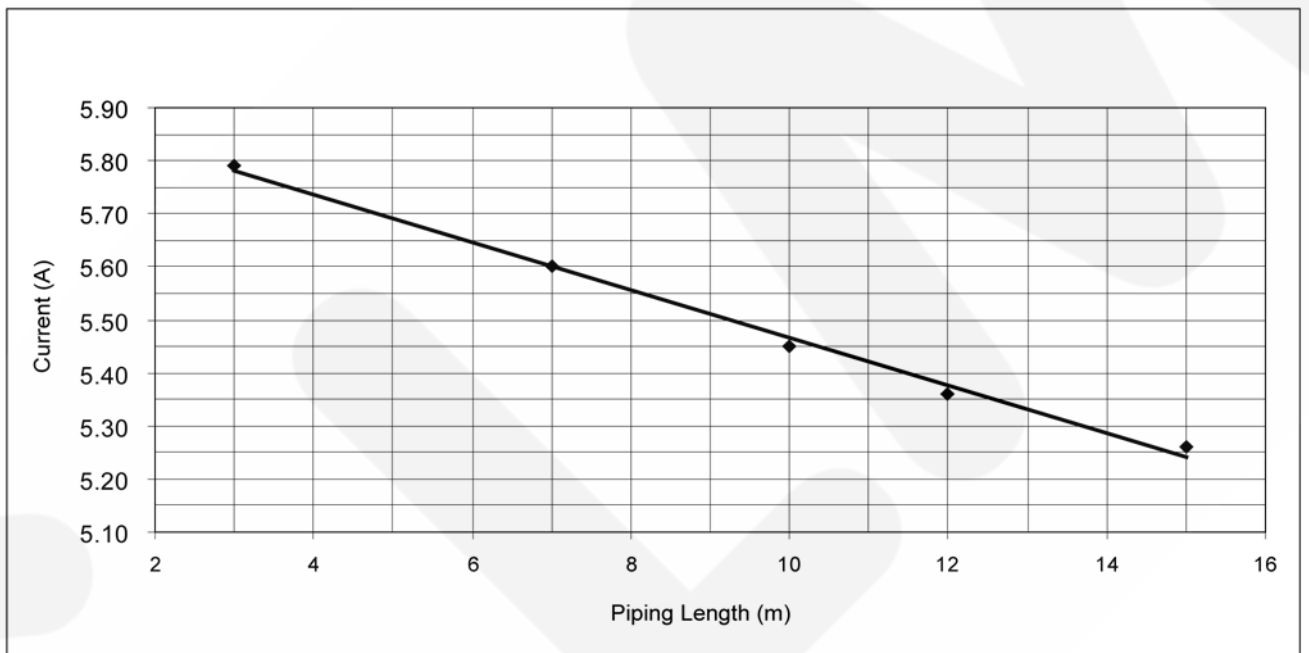
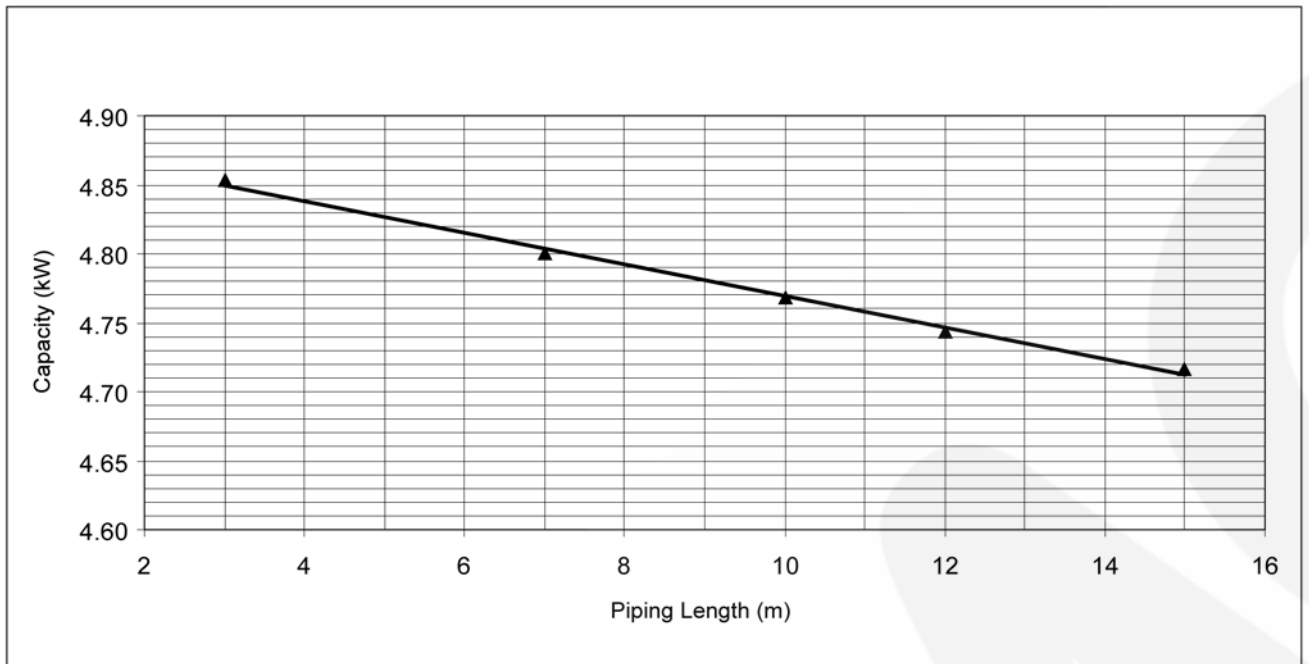

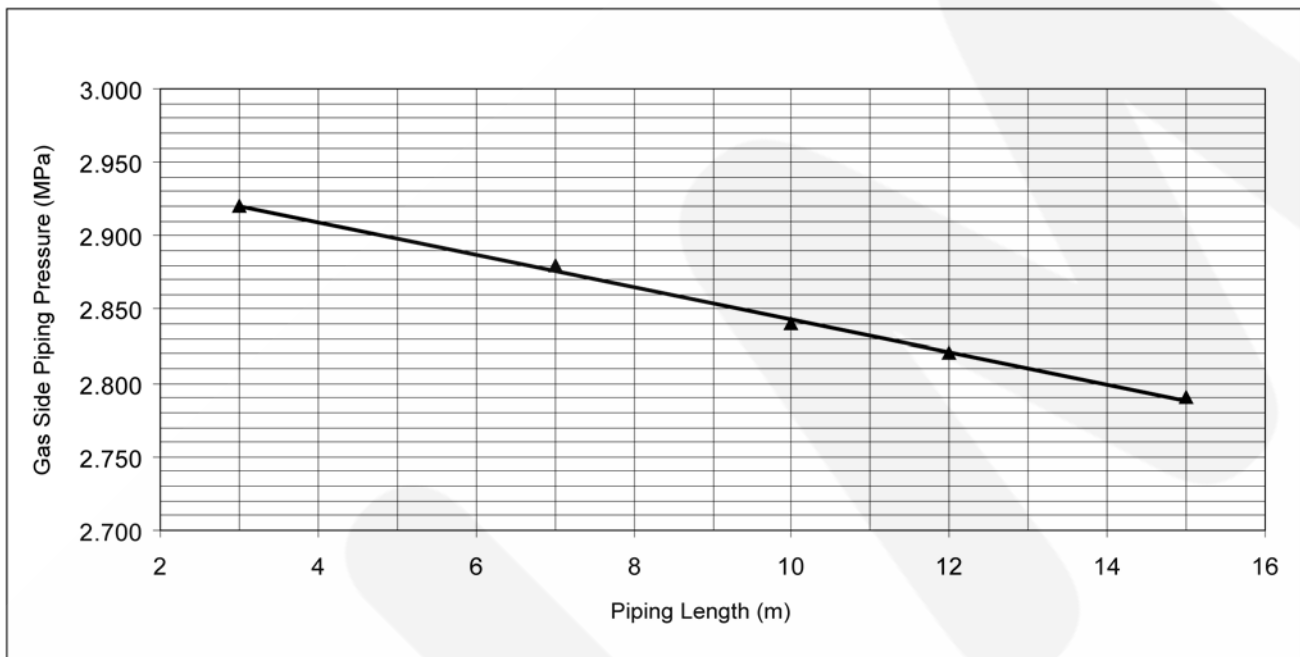
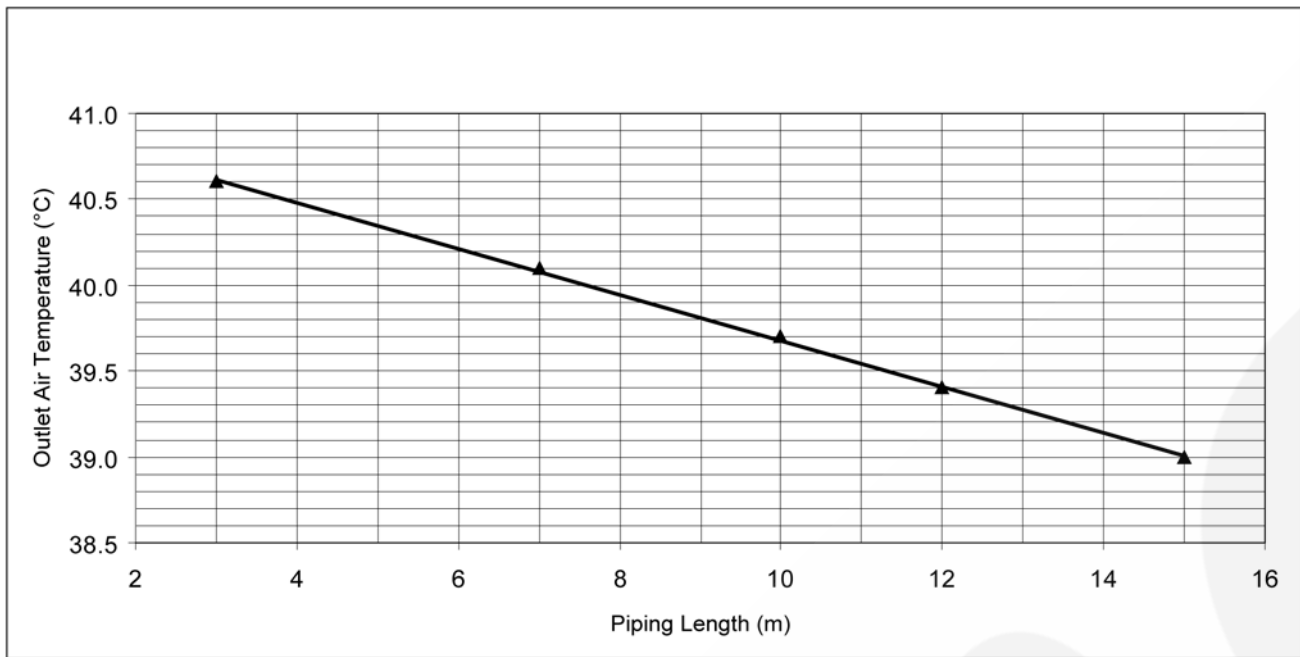

## 17.3. Sensible Capacity Chart

### Condition

Indoor temperature : 27°C / 19°C

Outdoor temperature : 35°C / 24°C

### CS-XE9EKE CU-XE9EKE

230V - 240V Indoor wet bulb temperature	Outdoor Temperature (°C)											
	30			35			40			46		
	TC	SHC	IP	TC	SHC	IP	TC	SHC	IP	TC	SHC	IP
17.0°C	2.58	1.96	0.52	2.41	1.88	0.56	2.24	1.80	0.60	2.04	1.71	0.65
19.0°C				2.60		0.57						
19.5°C	2.83	2.05	0.53	2.65	1.97	0.57	2.46	1.89	0.61	2.24	1.80	0.66
22.0°C	3.09	2.12	0.54	2.88	2.04	0.58	2.68	1.97	0.62	2.44	1.88	0.67

### CS-XE12EKE CU-XE12EKE

230V - 240V Indoor wet bulb temperature	Outdoor Temperature (°C)											
	30			35			40			46		
	TC	SHC	IP	TC	SHC	IP	TC	SHC	IP	TC	SHC	IP
17.0°C	3.47	2.63	0.81	3.24	2.52	0.87	3.02	2.43	0.93	2.74	2.30	1.00
19.0°C				3.50		0.88						
19.5°C	3.81	2.76	0.82	3.56	2.65	0.88	3.31	2.55	0.95	3.01	2.43	1.02
22.0°C	4.15	2.86	0.84	3.88	2.75	0.90	3.61	2.65	0.96	3.28	2.53	1.04

TC - Total Cooling Capacity (kW)

SHC - Sensible Heat Capacity (kW)

IP - Input Power (kW)

# 18 Exploded View and Replacement Parts List

## 18.1. Indoor Unit

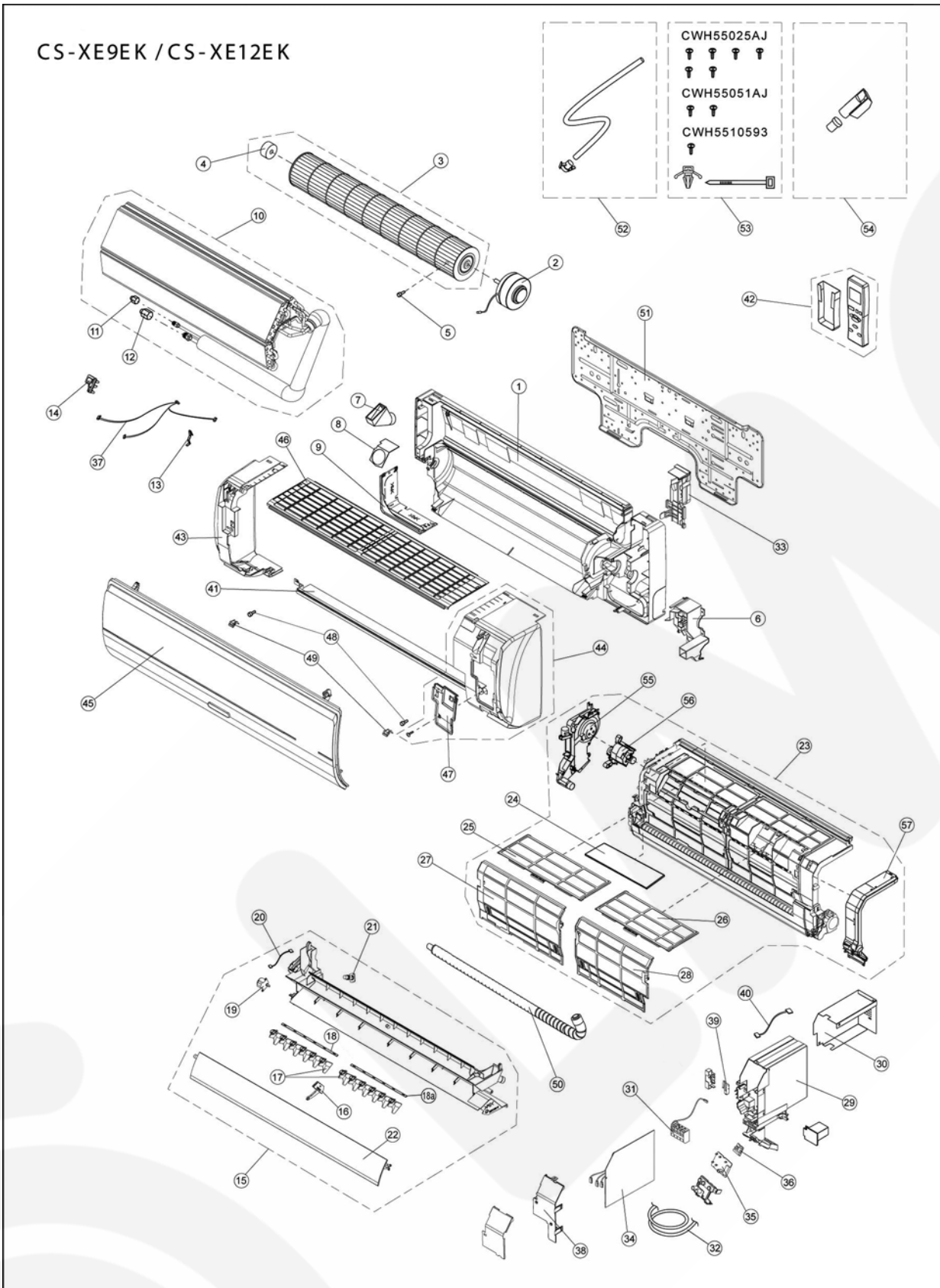

Note:  
 The above exploded view is for the purpose of parts disassembly and replacement.  
 The non-numbered parts are not kept as standard service parts.

REF. NO.	PART NAME & DESCRIPTION	QTY.	CS-XE9EKE	CS-XE12EKE	REMARKS
1	CHASSY COMPLETE	1	CWD50C1507	←	
2	FAN MOTOR	1	CWA981172J	←	0
3	CROSS FLOW FAN COMPLETE	1	CWH02C1045	←	
4	BEARING ASS'Y	1	CWH64K007	←	
5	SCREW - CROSS FLOW FAN	1	CWH551146	←	
6	CASING FOR FAN MOTOR	1	CWD911567	←	
7	DUCT - COMPLETE	1	CWD22C1037	←	
8	RETAINING RING	1	CWH581004	←	
9	L-SHAPE PLATE - FOR CHASSY	1	CWD601091	←	
10	EVAPORATOR CO.	1	CWB30C1813	CWB30C1814	
11	FLARE NUT	1	CWT251030 (1/4")	←	
12	FLARE NUT	1	CWT251031 (3/8")	CWT251032 (1/2")	
13	CLIP FOR SENSOR	1	CWH32143	←	
14	INTAKE AIR SENSOR HOLDER	1	CWH32142	←	
15	DISCHARGE GRILLE COMPLETE	1	CWE20C2479	←	
16	FULCRUM	1	CWH621060	←	
17	VERTICAL VANE	12	CWE241184	←	
18	CONNECTING BAR	1	CWE261090	←	
18a	CONNECTING BAR	1	CWE261087	←	
19	AIR SWING MOTOR	1	CWA981105J	←	0
20	LEAD WIRE - AIR SWING MOTOR	1	CWA67C5947	←	
21	CAP - DRAIN TRAY	1	CWH521096	←	
22	HORIZONTAL VANE COMPLETE	1	CWE24C1153	←	
23	FILTER CLEANING DEVICE CO.	1	CWD01C1028	←	
24	SUPER ALLERU BUSTER FILTER	1	CWD001202	←	
25	AIR FILTER (TOP LEFT)	1	CWD001194	←	
26	AIR FILTER (TOP RIGHT)	1	CWD001178	←	
27	AIR FILTER - COMPLETE (FRONT LEFT)	1	CWD00C1167	←	
28	AIR FILTER - COMPLETE (FRONT RIGHT)	1	CWD00C1168	←	
29	CONTROL BOARD CASING	1	CWH102288	←	
30	CONTROL BOARD COVER	1	CWH131250	←	
31	TERMINAL BOARD COMPLETE	1	CWA28C2265	←	0
32	POWER SUPPLY CORD	1	CWA20C2498	←	
33	BACK COVER CHASSIS	1	CWD932590	←	
34	ELECTRONIC CONTROLLER - MAIN	1	CWA73C2119	CWA73C2120	0
35	ELECTRONIC CO. - INDICATOR & RECEIVER	1	CWA744233	←	0
36	ELECTRONIC CO. - PUSH BUTTON	1	CWA744189	←	0
37	SENSOR COMPLETE	1	CWA50C2333	←	0
38	CONTROL BOARD COVER	1	CWH13C1134	←	
39	SAFETY SWITCH - FOR INTAKE GRILLE	1	K0KABF000013	←	0
40	LEAD WIRE FOR SAFETY SWITCH	1	CWA67C6062	←	
41	PLATE COVER	1	CWD91C0065	←	
42	REMOTE CONTROL COMPLETE	1	CWA75C2919	←	0
43	FRONT GRILLE COMPLETE - LEFT	1	CWE11C3453	←	
44	FRONT GRILLE COMPLETE - RIGHT	1	CWE11C3454	←	
45	INTAKE GRILLE COMPLETE	1	CWE22C1238	←	
46	INTAKE GRILLE COMPLETE	1	CWE22C1290	←	
47	GRILLE DOOR	1	CWE141089	←	
48	SCREW - FRONT GRILLE	2	XTT4+16CFJ	←	
49	CAP - FRONT GRILLE	2	CWH521139	←	
50	DRAIN HOSE	1	CWH851063	←	
51	INSTALLATION PLATE	1	CWH361077	←	
52	FLEXIBLE PIPE ASS'Y	1	CWH85K1002	←	
53	ACCESSORY - COMPLETE - SCREW	1	CWH82C1357	←	
54	ACCESSORY - COMPLETE - DAMPER	1	CWH82C1390	←	
55	VENTILATION DEVICE COMPLETE	1	CWH20C1004	←	
56	GEAR COMPLETE	1	CWH68C1025	←	
57	NOZZLE COMPLETE	1	CWH43C1008	←	

(Note)

- All parts are supplied from PHAAM, Malaysia (Vendor Code: 061).
- "O" marked parts are recommended to be kept in stock.

## 18.2. Outdoor Unit

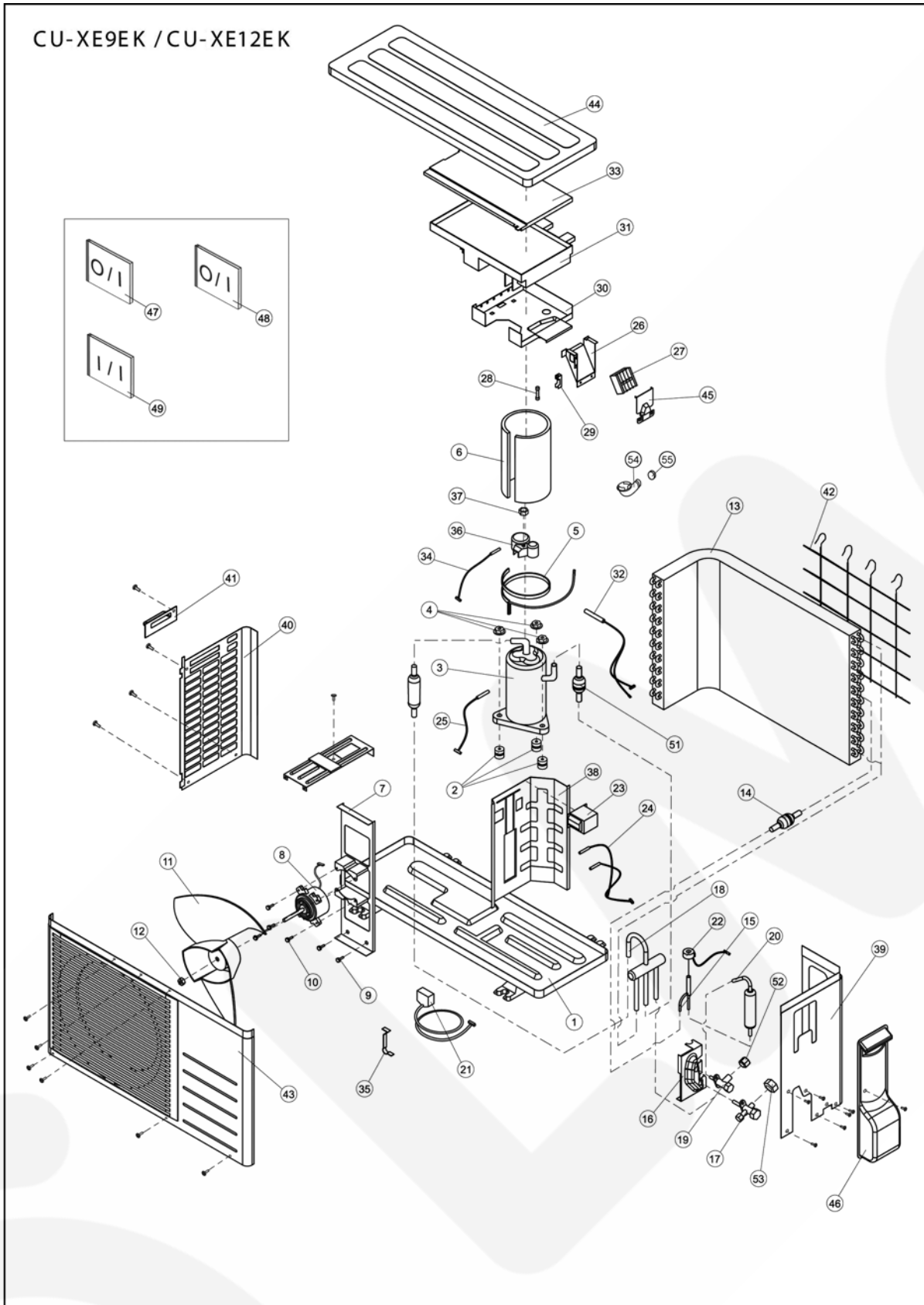

Note:  
The above exploded view is for the purpose of parts disassembly and replacement.  
The non-numbered parts are not kept as standard service parts.

REF. NO.	PART NAME & DESCRIPTION	QTY.	CU-XE9EKE	CU-XE12EKE	REMARKS
1	CHASSY ASS'Y	1	CWD50K2117	←	
2	ANTI - VIBRATION BUSHING	3	CWH50077	←	
3	COMPRESSOR, DC 220V	1	5CS110XBD04	←	0
4	NUT - COMPRESSOR MOUNT	3	CWH56000J	←	
5	CRANKCASE HEATER	1	CWA341026	←	
6	SOUND PROOF MATERIAL	1	CWVG300001	←	
7	FAN MOTOR BRACKET	1	CWD541021	←	
8	FAN MOTOR, DC 40W 3PH	1	ARW44W8P40AC	←	0
9	SCREW - BRACKET FAN MOTOR	2	CWH551060J	←	
10	SCREW - FAN MOTOR MOUNT	4	CWH55252J	←	
11	PROPELLER FAN ASS'Y	1	CWH03K1013	←	
12	NUT - PROPELLER FAN	1	CWH56053J	←	
13	CONDENSER CO.	1	CWB32C1741	←	
14	STRAINER	1	CWB11094	←	
15	TUBE ASS'Y (EXP. VALVE)	1	CWT01C3643	←	
16	HOLDER COUPLING	1	CWH351025	←	
17	3-WAY VALVE	1	CWB011165J	CWB011316J	0
18	4-WAY VALVE	1	CWB001037J	←	0
19	2-WAY VALVE	1	CWB021180J	←	0
20	DRYER	1	CWB101016J	←	0
21	V-COIL CO. FOR 4-WAY VALVE	1	CWA43C2144J	←	0
22	V-COIL COMPLETE FOR EXP. VALVE	1	CWA43C2058J	←	
23	REACTOR	1	CWA421050	GOA193M00001	
24	SENSOR COMPLETE	1	CWA50C2241	←	
25	SENSOR COMPLETE	1	CWA50C2281	←	
26	CONTROL BOARD CASING	1	CWH102294	←	
27	TERMINAL BOARD ASS'Y	1	CWA28K1021J	←	
28	FUSE, 250V	1	XBA2C31TR0	←	
29	FUSE HOLDERS	1	K3GB1BH00005	←	
30	CONTROL BOARD CASING	1	CWH102293	←	
31	ELECTRONIC CONTROLLER - MAIN	1	CWA73C1998R	CWA73C1999R	
32	OVER HEAT PROTECTOR COMPLETE	1	CWA14C1011	←	
33	CONTROL BOARD COVER	1	CWH131264	←	
34	SENSOR - COMPLETE	1	CWA50C2066	←	
35	CLIP FOR SENSOR	1	CWH321010	←	
36	TERMINAL COVER	1	CWH171001	←	
37	NUT FOR TERMINAL COVER	1	CWH7080300J	←	
38	SOUND PROOF BOARD	1	CWH151090	←	
39	CABINET SIDE PLATE	1	CWE041074A	←	
40	CABINET SIDE PLATE (L)	1	CWE041144A	←	
41	HANDLE	1	CWE161010	←	
42	WIRE NET	1	CWD041054A	←	
43	CABINET FRONT PLATE CO.	1	CWE06C1136	←	
44	CABINET TOP PLATE	1	CWE031014A	←	
45	CONTROL BOARD COVER	1	CWH131213	←	
46	CONTROL BOARD COVER COMPLETE	1	CWH13C1145	←	
47	OPERATION INSTRUCTIONS	1	CFW565101	←	
48	OPERATION INSTRUCTIONS	1	CFW565102	←	
49	INSTALLATION INSTRUCTIONS	1	CFW612909	←	
51	STRAINER	1	CWB111004	←	
52	FLARE NUT (1/4)	1	CWT251030	←	
53	FLARE NUT (3/8) (1/2)	1	CWT251031	CWT251032	
54	FLEXIBLE PIPE - L-TUBE	1	CWH5850080	←	
55	PACKING	1	CWB81012	←	

(Note)

- All parts are supplied from PHAAM, Malaysia (Vendor Code: 061).
- "O" marked parts are recommended to be kept in stock.