

Service Manual

Air Conditioner

CS-V28EKE CU-V28EKE

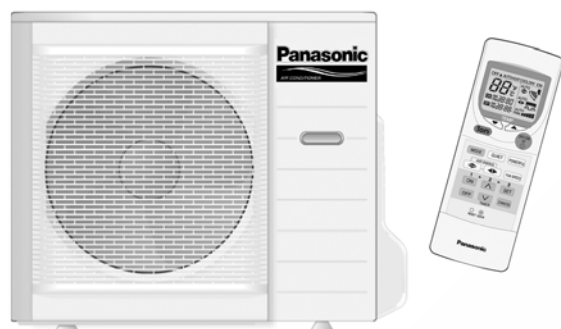

⚠ WARNING

This service information is designed for experienced repair technicians only and is not designed for use by the general public. It does not contain warnings or cautions to advise non-technical individuals of potential dangers in attempting to service a product. Products powered by electricity should be serviced or repaired only by experienced professional technicians. Any attempt to service or repair the product or products dealt with in this service information by anyone else could result in serious injury or death.

⚠ PRECAUTION OF LOW TEMPERATURE

In order to avoid frostbite, be assured of no refrigerant leakage during the installation or repairing of refrigeration circuit.

TABLE OF CONTENTS

	PAGE		PAGE
1 Safety Precautions -----	3	10.1. Select The Best Location -----	17
2 Specifications -----	5	10.2. Indoor/Outdoor Unit Installation Diagram -----	17
2.1. CS-V28EKE CU-V28EKE -----	5	10.3. Indoor Unit -----	18
3 Features -----	7	10.4. Outdoor Unit-----	22
4 Location of Controls and Components -----	8	11 Operation And Control -----	25
5 Dimensions -----	9	11.1. Cooling Operation-----	25
5.1. Indoor Unit & Remote Control-----	9	11.2. Soft Dry Operation-----	26
5.2. Outdoor Unit -----	10	11.3. Automatic Operation -----	27
6 Refrigeration Cycle Diagram -----	11	11.4. Operation Control -----	27
7 Block Diagram -----	12	11.5. Indoor Fan Speed Control -----	29
8 Wiring Connection Diagram -----	13	11.6. Outdoor Fan Speed Control-----	31
9 Printed Circuit Board -----	14	11.7. Vertical Airflow Direction Control-----	31
9.1. Indoor Unit-----	14	11.8. Horizontal Airflow Direction Control -----	32
9.2. Indicator And Receiver-----	16	11.9. Powerful Operation -----	32
10 Installation Instruction -----	17	11.10. Quiet Operation-----	32

Panasonic®

© 2005 Panasonic HA Air-Conditioning (M) Sdn Bhd (11969-T). All rights reserved. Unauthorized copying and distribution is a violation of law.

11.11. Ionizer Operation-----	33
11.12. Timer Control-----	35
11.13. Random Auto Restart Control -----	35
11.14. Remote Control Signal Receiving Sound -----	35
12 Servicing Mode -----	36
12.1. Auto OFF/ON Button-----	36
13 Troubleshooting Guide-----	38
13.1. Refrigeration Cycle System -----	38
13.2. Relationship Between The Condition Of The Air Conditioner And Pressure And Electric Current-----	39
13.3. Diagnosis Methods Of A Malfunction Of A Compressor And 4-way Valve -----	39
14 Disassembly and Assembly Instructions-----	40
14.1. Indoor Electronic Controllers, Cross Flow Fan and Indoor Fan Motor Removal Procedures -----	40
15 Technical Data -----	43
15.1. Thermostat Characteristics-----	43
15.2. Sensible Capacity Chart-----	44
15.3. Operation Characteristics-----	45
16 Exploded View and Replacement Parts List -----	47
16.1. CS-V28EKE -----	47
16.2. CU-V28EKE -----	49

1 Safety Precautions

- Read the following "SAFETY PRECAUTIONS" carefully before perform any servicing.
- Electrical work must be installed or serviced by a licensed electrician. Be sure to use the correct rating of the power plug and main circuit for the model installed.
- The caution items stated here must be followed because these important contents are related to safety. The meaning of each indication used is as below.
Incorrect installation or servicing due to ignoring of the instruction will cause harm or damage, and the seriousness is classified by the following indications.





 WARNING	This indication shows the possibility of causing death or serious injury.
--	---



 CAUTION	This indication shows the possibility of causing injury or damage to properties.
--	--

The items to be followed are classified by the symbols:

	This symbol denotes item that is PROHIBITED from doing.
---	---

- Carry out test running to confirm that no abnormality occurs after the servicing. Then, explain to user the operation, care and maintenance as stated in instructions. Please remind the customer to keep the operating instructions for future reference.

 WARNING	
1. Engage dealer or specialist for installation and servicing. If installation or servicing done by the user is defective, it will cause water leakage, electrical shock or fire.	
2. Install according to this installation instructions strictly. If installation is defective, it will cause water leakage, electrical shock or fire.	
3. Use the attached accessories parts and specified parts for installation and servicing. Otherwise, it will cause the set to fall, water leakage, fire or electrical shock.	
4. Install at a strong and firm location which is able to withstand the set's weight. If the strength is not enough or installation is not properly done, the set will drop and cause injury.	
5. For electrical work, follow the local national wiring standard, regulation and the installation instruction. An independent circuit and single outlet must be used. If electrical circuit capacity is not enough or defect found in electrical work, it will cause electrical shock or fire.	
6. Use the specified cable and connect tightly for indoor/outdoor connection. Connect tightly and clamp the cable so that no external force will be acted on the terminal. If connection or fixing is not perfect, it will cause heat-up or fire at the connection.	
7. Wire routing must be properly arranged so that control board cover is fixed properly. If control board cover is not fixed perfectly, it will cause heat-up at connection point of terminal, fire or electrical shock.	
8. When connecting the piping, do not allow air or any substances other than the specified refrigerant to enter the refrigeration cycle. Otherwise, this may lower the capacity, cause abnormally high pressure in the refrigeration cycle, and possibly result in explosion and injury.	
9. Thickness of copper pipes used must be more than 0.8 mm. Never use copper pipes thinner than 0.8 mm.	
10. It is desirable that the amount of residual oil is less than 40 mg/10 m.	
11. Do not modify the length of the power supply cord or use of the extension cord, and do not share the single outlet with other electrical appliances. Otherwise, it will cause fire or electrical shock.	

 CAUTION	
1. The equipment must be earthed. It may cause electrical shock if grounding is not perfect.	
2. Do not install the unit at place where leakage of flammable gas may occur. In case gas leaks and accumulates at surrounding of the unit, it may cause fire.	

 **CAUTION**

3. Carry out drainage piping as mentioned in installation instructions. If drainage is not perfect, water may enter the room and damage the furniture.
4. Pb free solder has a higher melting point than standard solder; typically the melting point is 50 - 70°F (30 - 40°C) higher. Please use a high temperature soldering iron. In case of the soldering iron with temperature control, please set it to 700 ± 20°F (370 ± 10°C). Pb free solder will tend to splash when heated too high (about 1100°F/600°C).

ATTENTION

1. Selection of the installation location. Select an installation location which is rigid and strong enough to support or hold the unit, and select a location for easy maintenance.
2. Power supply connection to the conditioner. Connect the power supply cord of the air conditioner to the mains using one of the following methods. Power supply point shall be the place where there is ease for access for the power disconnection in case of emergency. In some countries, permanent connection of this room air conditioner to the power supply is prohibited.
 1. Power supply connection to the receptacle using a power plug. Use an approved power plug with earth pin for the connection to the socket.
 2. Power supply connection to a circuit breaker for the permanent connection. Use an approved circuit breaker for the permanent connection. It must be a double pole switch with a minimum 3.5 mm contact gap.
3. Do not release refrigerant during piping work for installation, servicing reinstallation and during repairing a refrigeration parts. Take care of the liquid refrigerant, it may cause frostbite.
4. Installation work. It may need two people to carry out the installation work.
5. Do not install this appliance in a laundry room or other location where water may drip from the ceiling, etc.

2 Specifications

2.1. CS-V28EKE CU-V28EKE

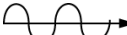
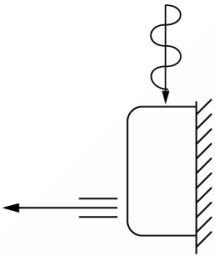
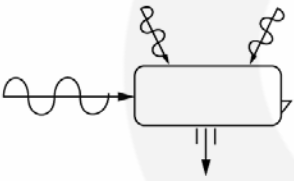
		Unit	CS - V28EKE	CU - V28EKE	
Performance Test Condition			EUROVENT		
Power Source (Phase, Voltage, Cycle)		ø, V, Hz	Single, 230, 50		
Cooling Capacity		kW (BTU/h)	7.91 (27,000)		
Moisture Removal		l/h (Pint/h)	4.6 (9.7)		
Airflow Method		OUTLET  INTAKE 	SIDE VIEW 	TOP VIEW 	
Air Volume	Lo	m ³ /min (cfm)	16.8 (590)	28.8 (1,020)	
	Me	m ³ /min (cfm)	18.8 (660)	—	
	Hi	m ³ /min (cfm)	20.1 (710)	53.0 (1,870)	
	SHi	m ³ /min (cfm)	20.9 (740)	—	
Noise Level		dB (A)	High 49, Low 44	High 55	
		Power level (dB)	62	70	
Electrical Data	Input Power	kW	2.46		
	Running Current	A	11.3		
	EER	W/W (BTU/hW)	3.22 (10.98)		
	Starting Current	A	55.5		
Piping Connection Port (Flare Piping)		inch	G ; Half Union 5/8"	G : 3-way valve 5/8"	
		inch	L ; Half Union 1/4"	L ; 2-way valve 1/4"	
Pipe Size (Flare Piping)		inch	G ; (gas side) ; 5/8"	G ; (gas side) ; 5/8"	
		inch	L ; (liquid side) ; 1/4"	L ; (liquid side) ; 1/4"	
Drain	Inner diameter	mm	16	—	
Hose	Length	mm	650	—	
Power Cord	Length	m	—	—	
	Number of core-wire		—	—	
Dimensions	Height	inch (mm)	13 - 13/32 (340)	29 - 17/32 (750)	
	Width	inch (mm)	45 - 9/32 (1,150)	34 - 7/16 (875)	
	Depth	inch (mm)	10 - 1/4 (260)	13 - 19/32 (345)	
Net Weight		lb (kg)	40 (18.0)	137 (62.0)	
Compressor	Description		—	Rotary (1 cylinder) rolling piston type	
	Motor	Type	—	Induction (2-poles)	
	Rated	Output	kW	1.9	
Air Circulation	Description		Cross-flow Fan	Propeller Fan	
	Material		ASHT-18	PP	
	Motor	Type	Transistor (8-poles)	Induction (6-poles)	
		Input	W	166	
	Rated	Output	W	80	
	Fan Speed	Low	rpm	1,070	470
		Medium	rpm	1,170	—
		High	rpm	1,270	875
SuperHigh		rpm	1,350	—	

		Unit	CS - V28EKE	CU - V28EKE
Heat Exchanger	Description		Evaporator	Condenser
	Tube material		Copper	Copper
	Fin material		Aluminium (Pre Coat)	Aluminium
	Fin Type		Slit Fin	Corrugated Fin
	Row / Stage		(Plate fin configuration, forced draft)	
			2 x 14	2 x 34
	FPI		18	17
Size (W x H x L)	mm	44 × 355.6 × 880	850.5 × 714.0 × 25.4 870.5	
Refrigerant Control Device			—	Capillary Tube
Refrigerant Oil		(cm ³)	—	FV50S (1,130)
Refrigerant (R-410A)		g (oz.)	—	1,900 (67.1)
Thermostat			Electronic Control	Mechanical Control
Protection Device			—	Inner Protector
Capillary Tube	Length	mm	—	830
	Flow Rate	l/min	—	20.9
	Inner Diameter	mm	—	2.0
Air Filter	Material		P.P.	—
	Style		Honeycomb	
Capacity Control			Capillary Tube	
Compressor Capacitor		μF, VAC	—	60 μF, 440VAC
Fan Motor Capacitor		μF, VAC	—	5.0 μF, 440VAC

Note:

- Specifications are subject to change without notice for further improvement.

3 Features

- High efficiency.
 - Compact design.
 - Wider range of horizontal discharge air.
 - Air Filter with function to reduce dust and smoke.
 - Automatic air swing and manual adjusted by Remote Control for horizontal and vertical airflow.
 - Long installation piping up to 30 meter.
 - Supersonic Air Purifying System with Super Alleru-Buster.
 - Inactive various harmful airborne elements including allergens, viruses and bacteria.
 - Generated supersonic waves enhance the ability to collect dust and dirt in the air.
 - Random auto restart after power failure for safety restart operation.
 - Gas leakage detection.
 - Prevent Compressor reverse cycle.
 - Inner protector to protect Compressor.
 - Noise prevention during soft dry operation.
 - Dew prevention control (Cooling & Soft Dry).
- **Operation Improvement**
 - Quiet mode to provide quiet operation.
 - Powerful mode to reach the desired room temperature quickly.
 - Ionizer control for generating negative ion in discharged air.
 - 24-hour timer setting.
 - **Serviceability Improvement**
 - Removable and washable Front Panel.
 - **Environmental Friendly**
 - R410A, which does not contain chlorine, is used as its refrigerant, so there is no danger of damage to the ozone layer in Stratosphere.

4 Location of Controls and Components

Indoor Unit

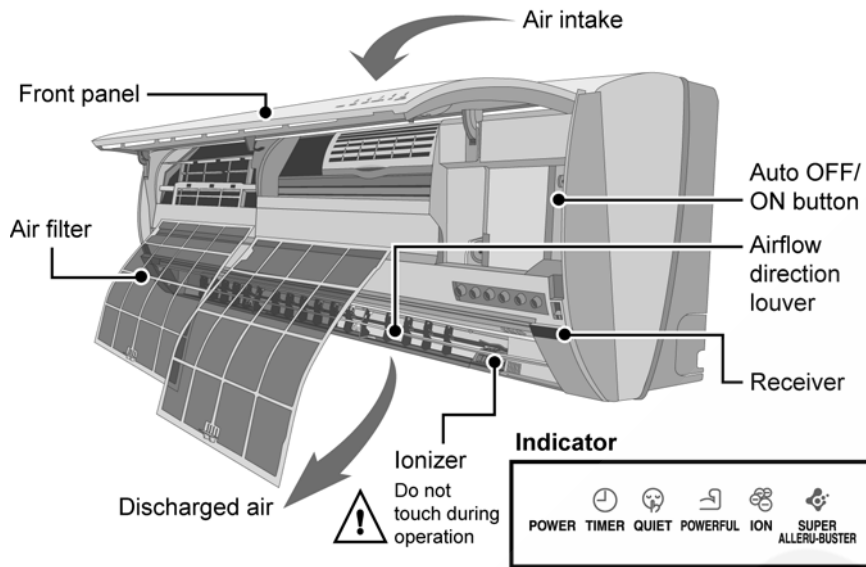

Outdoor Unit

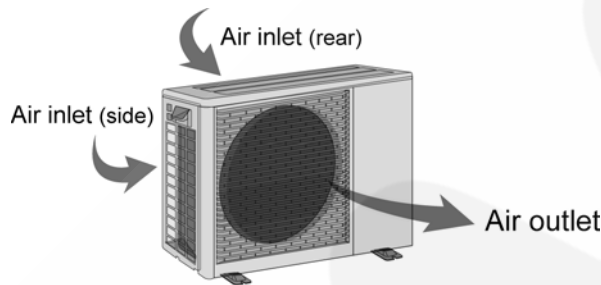

Remote Control

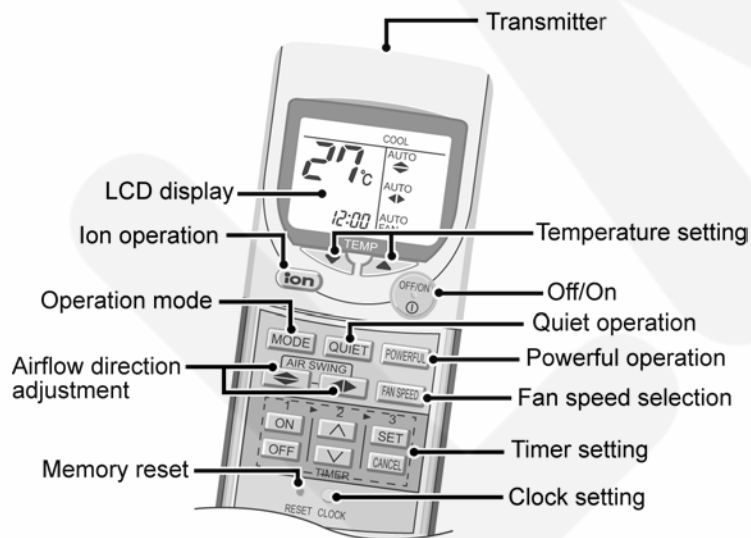

5 Dimensions

5.1. Indoor Unit & Remote Control

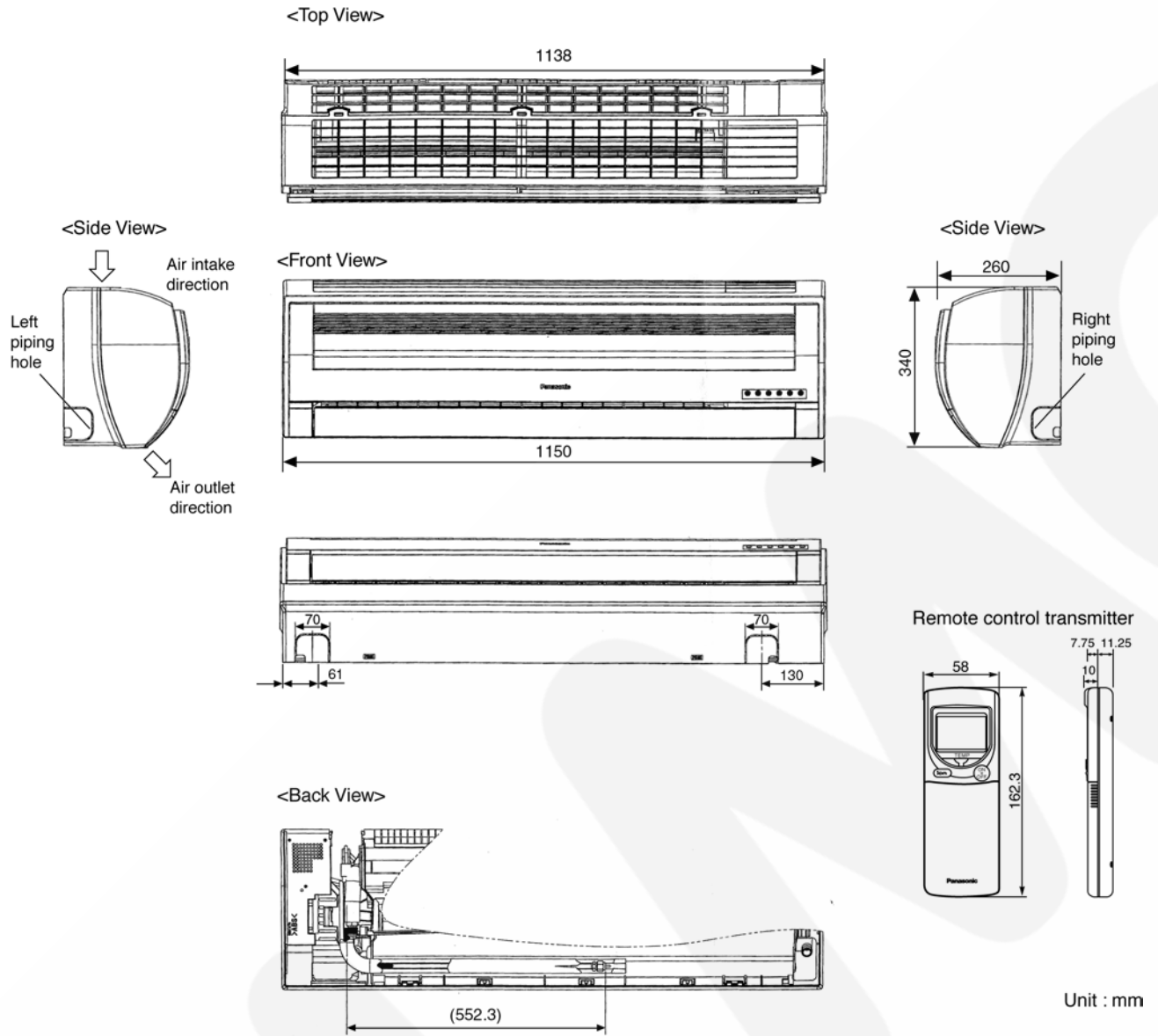

Relative position between the indoor unit and the installation plate <Front View>

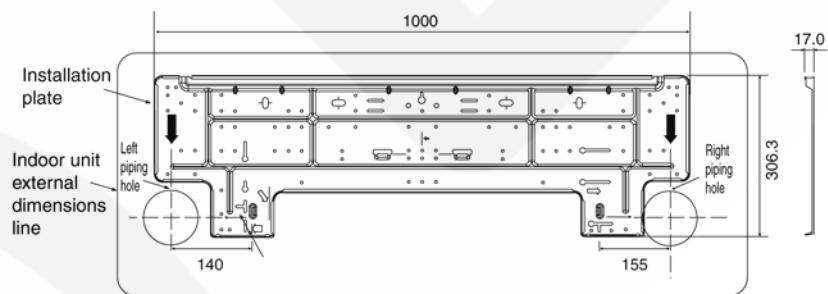

5.2. Outdoor Unit

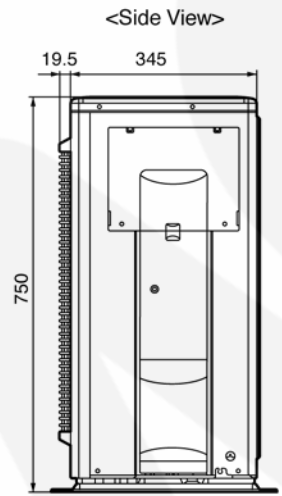
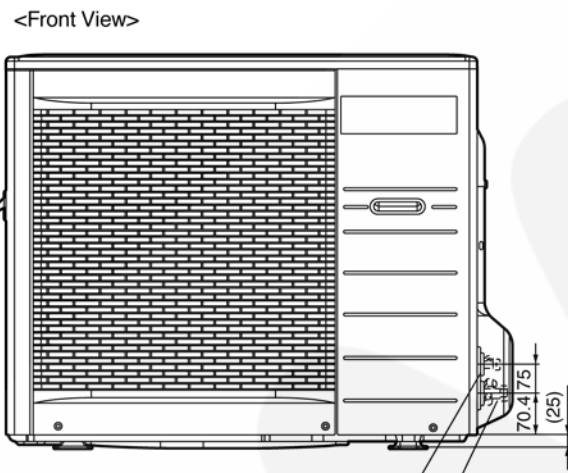
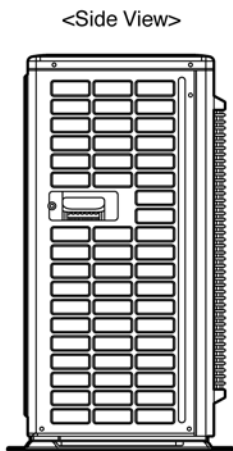
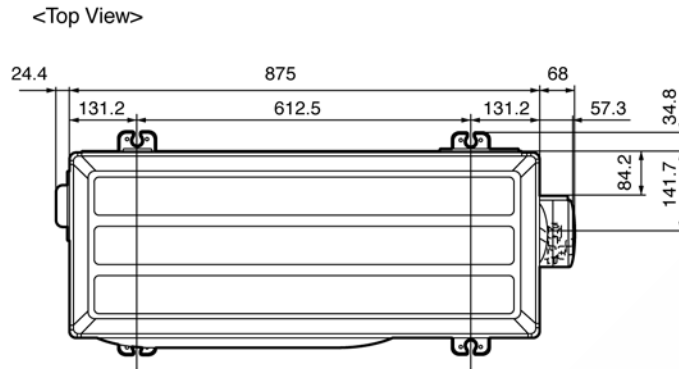
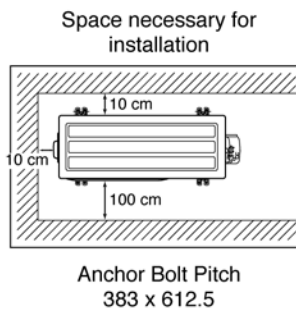

3-way valve at Gas side (Low Pressure)

2-way valve at Liquid side (High Pressure)

Unit: mm

6 Refrigeration Cycle Diagram

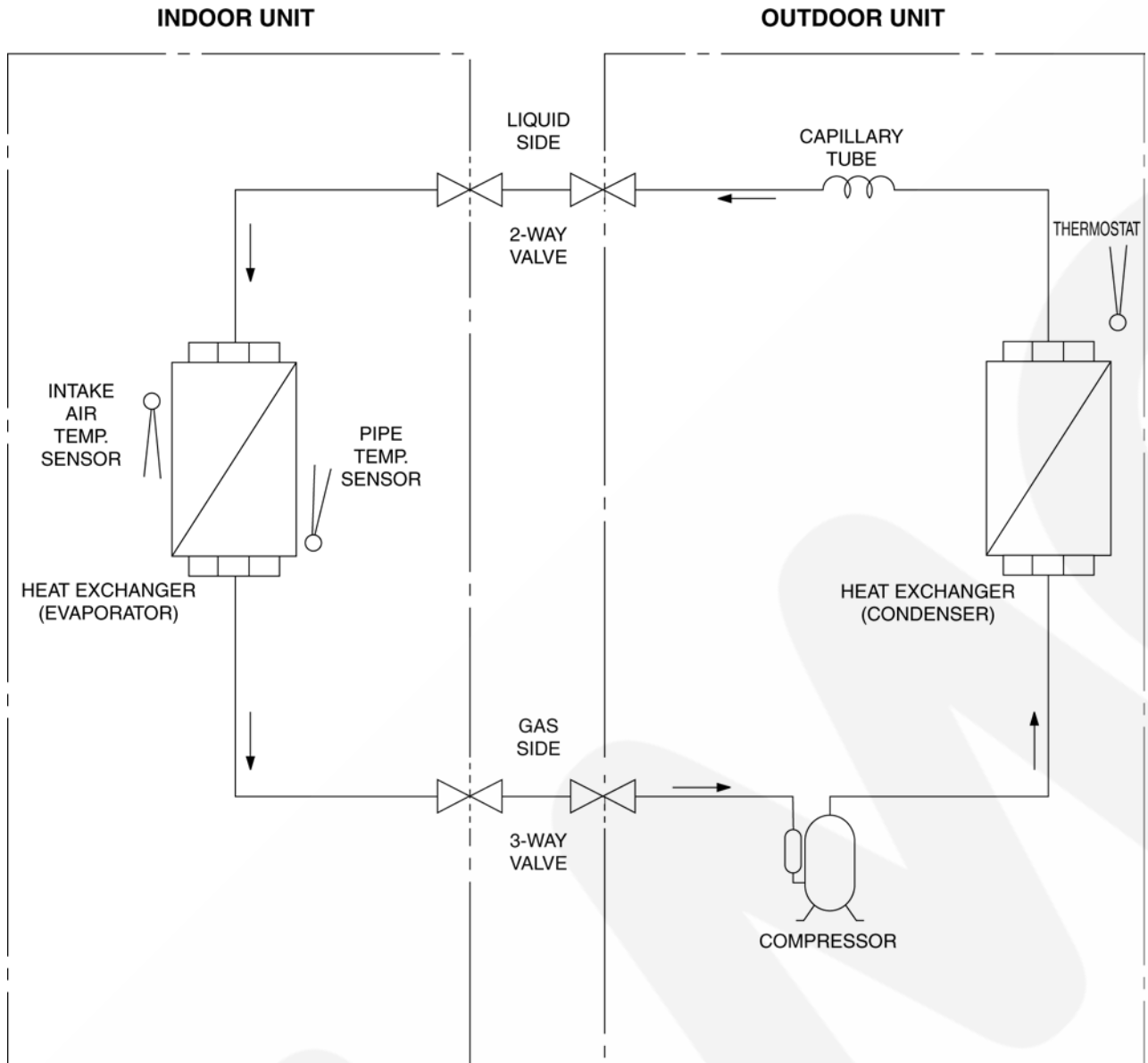

7 Block Diagram

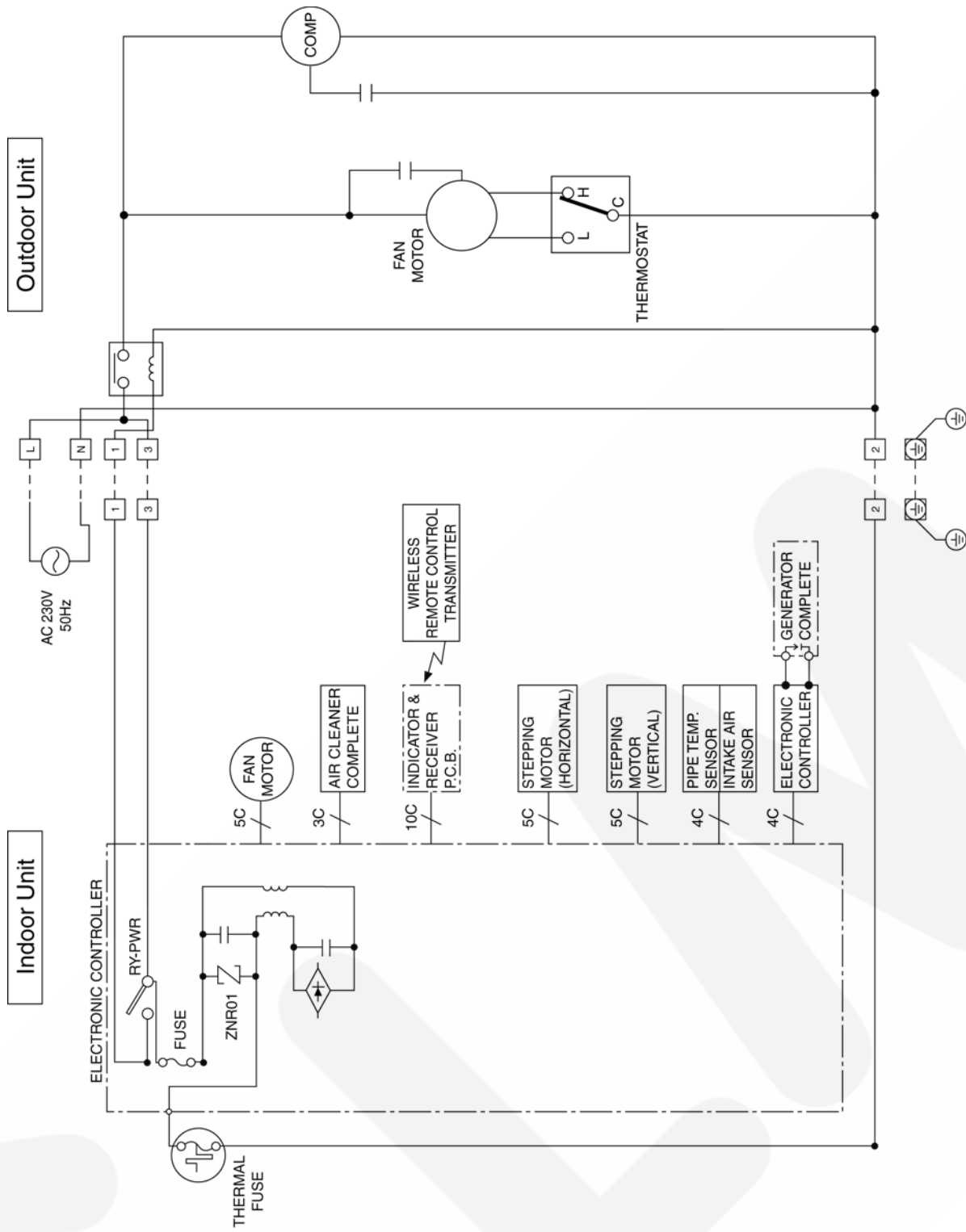

⊞ Indicates the electronic control unit.

⊞ "C" Indicates the number of core wires. (Example: 4C=4 core wires)

8 Wiring Connection Diagram

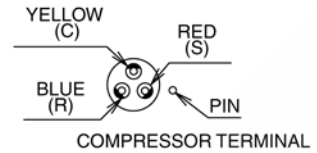
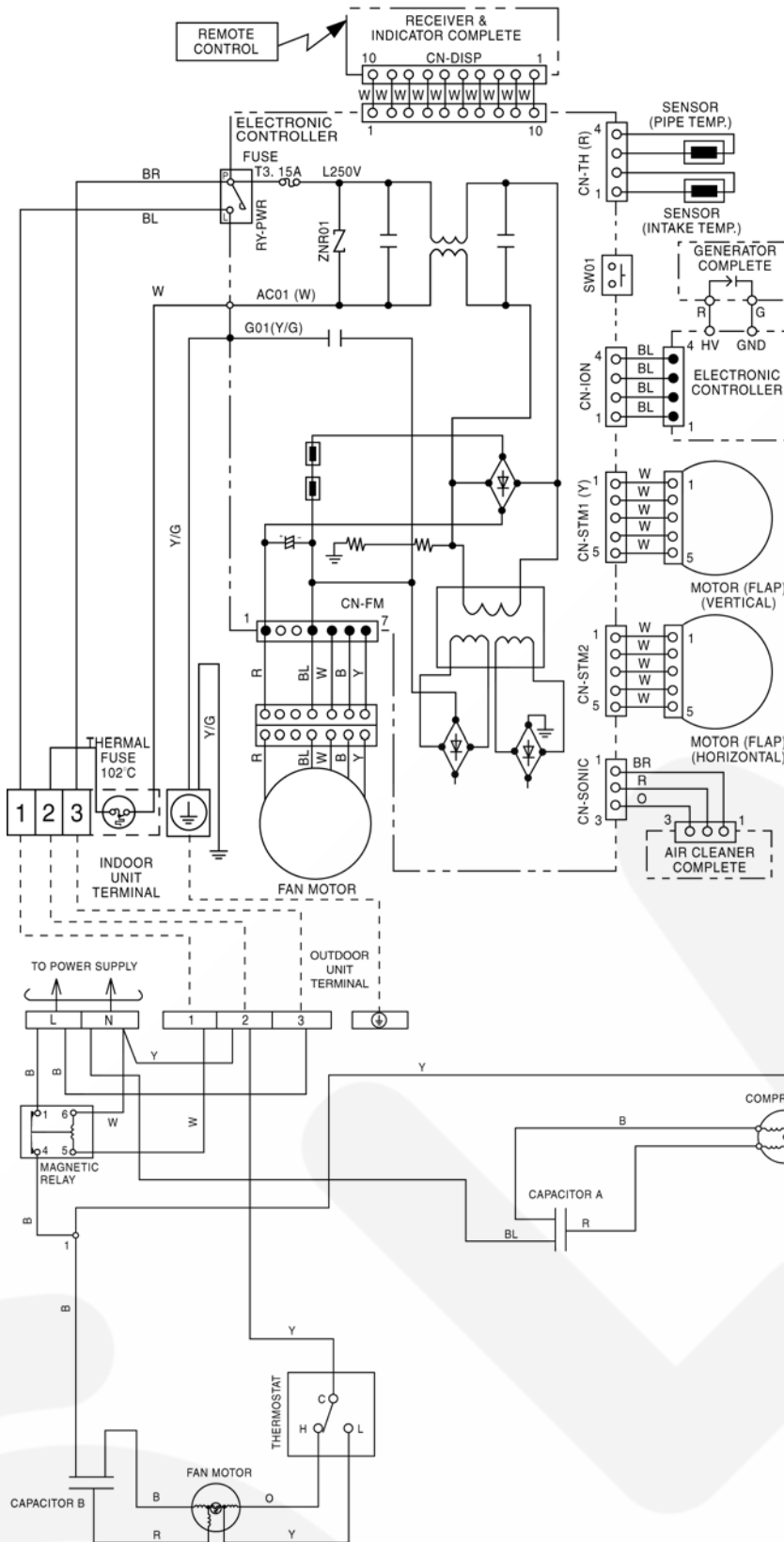

REMARKS

- B : BLUE
- BR : BROWN
- BL : BLACK
- W : WHITE
- R : RED
- O : ORANGE
- P : PINK
- V : VIOLET
- GR : GRAY
- Y/G : YELLOW / GREEN

Resistance of Outdoor Fan Motor Windings

MODEL	CU-V28EKE
CONNECTION	CWA951354
YELLOW - BLUE	58 Ω
YELLOW - ORANGE	144.6 Ω
YELLOW - RED	62.1 Ω

Note: Resistance at 20°C of ambient temperature.

Resistance of Compressor Windings

MODEL	CU-V28EKE
CONNECTION	5JS290DAD21
C - R	1.011 Ω
C - S	1.940 Ω

Note: Resistance at 20°C of ambient temperature.

9 Printed Circuit Board

9.1. Indoor Unit

BOTTOM VIEW

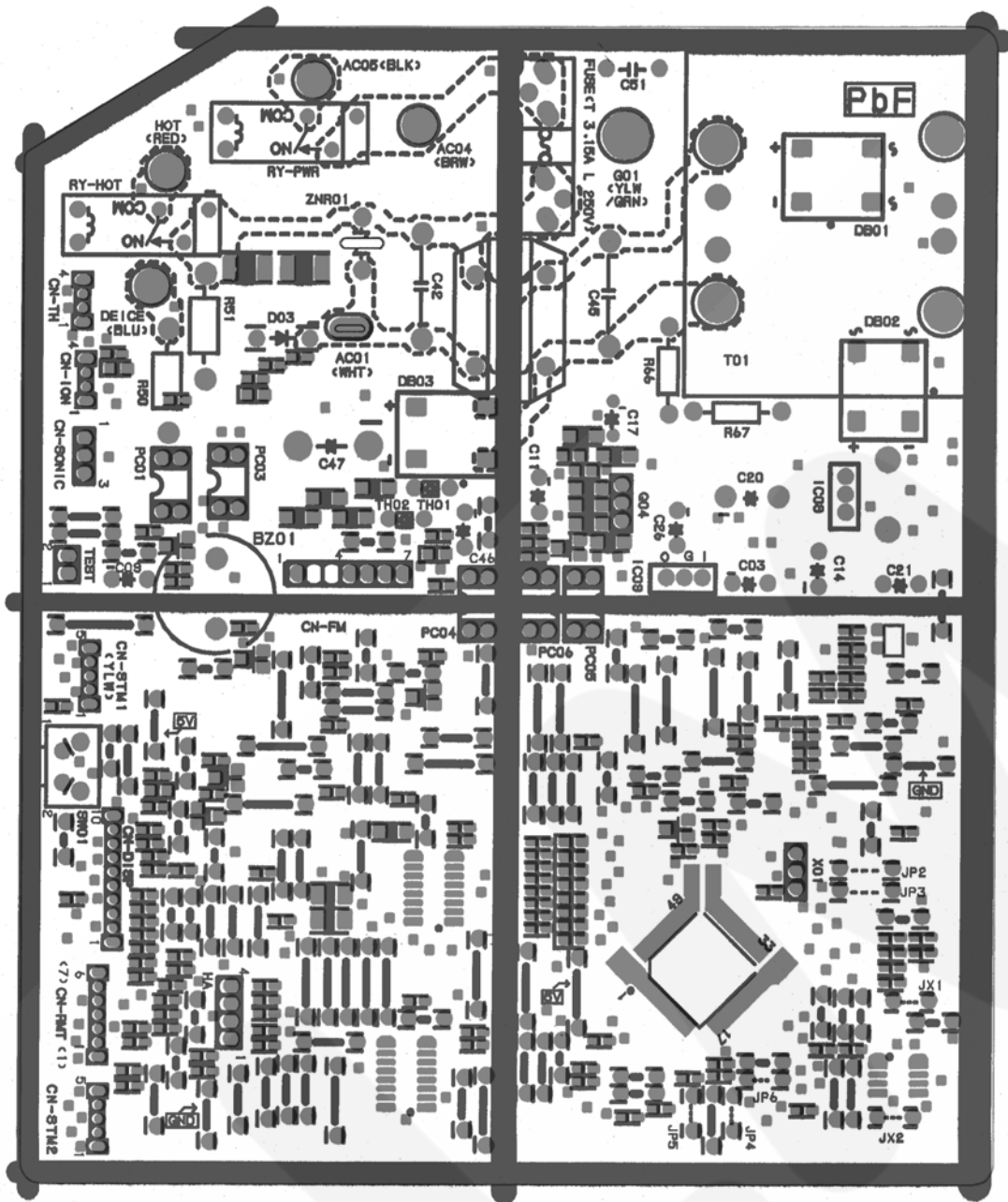

TOP VIEW

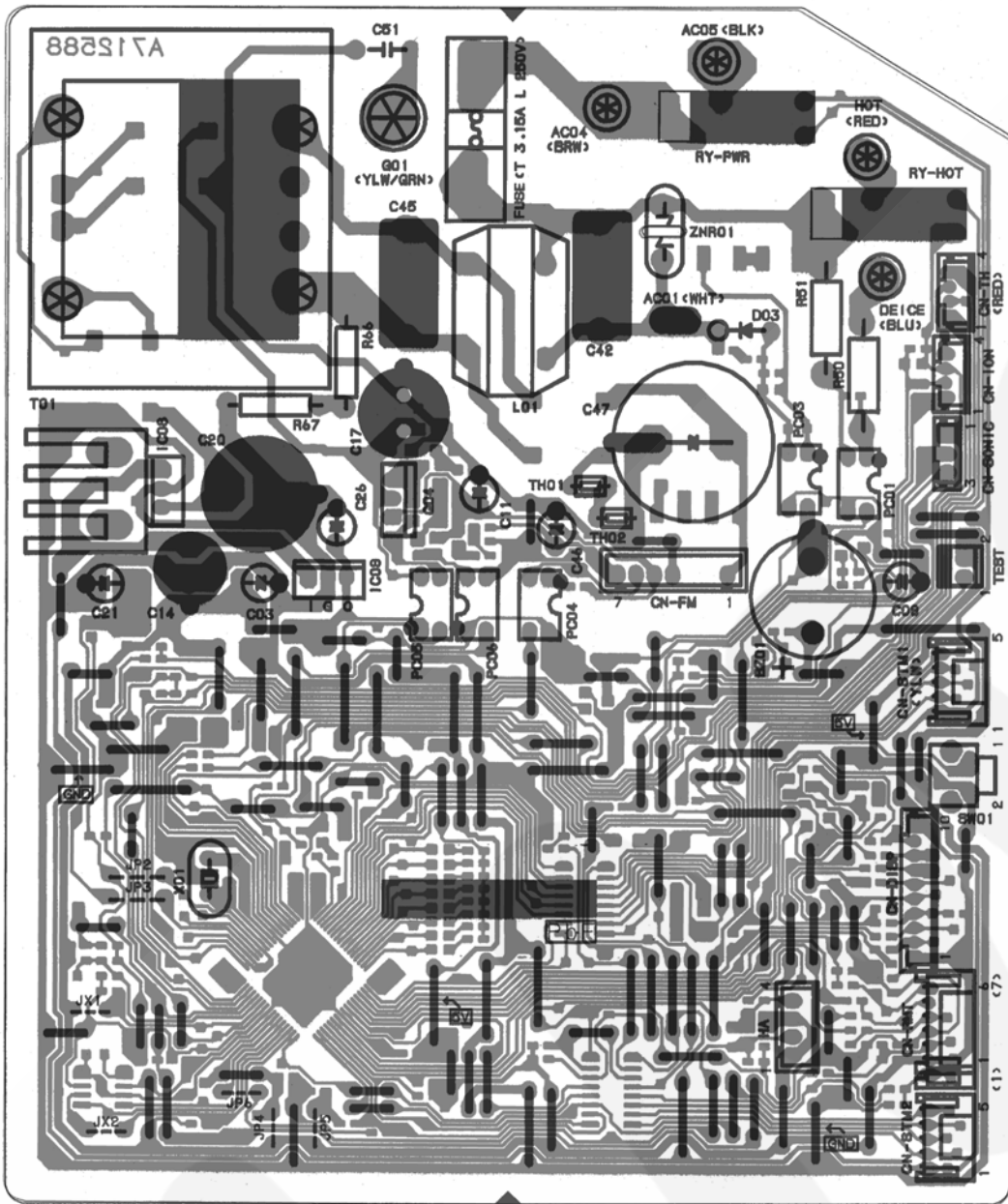

9.2. Indicator And Receiver

BOTTOM VIEW

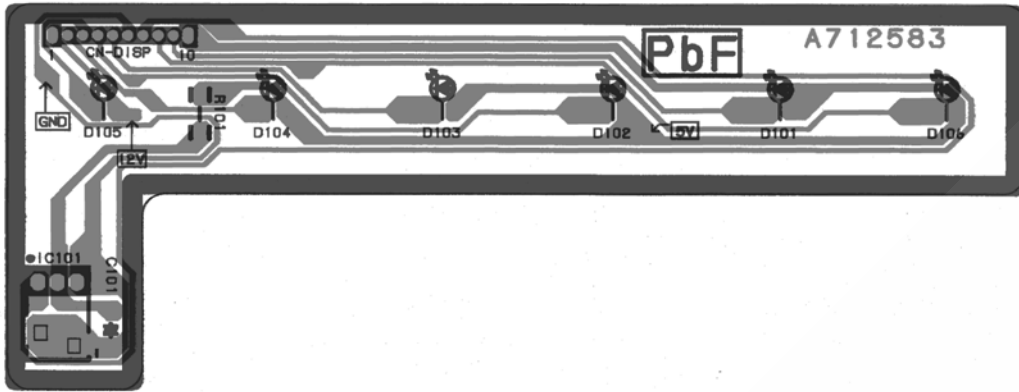

TOP VIEW

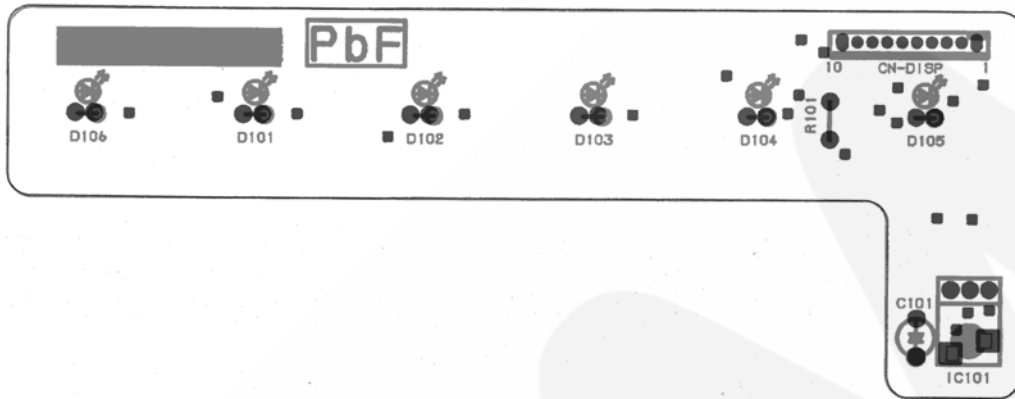

10 Installation Instruction

10.1. Select The Best Location

INDOOR UNIT

- There should not be any heat source or steam near the unit.
- There should not be any obstacles blocking the air circulation.
- A place where air circulation in the room is good.
- A place where drainage can be easily done.
- A place where noise prevention is taken into consideration.
- Do not install the unit near the door way.
- Ensure the spaces indicated by arrows from the wall, ceiling, fence or other obstacles.
- Recommended installation height for indoor unit shall be at least 2.5 m.

OUTDOOR UNIT

- If an awning is built over the unit to prevent direct sunlight or rain, be careful that heat radiation from the condenser is not obstructed.
- There should not be any animal or plant which could be affected by hot air discharged.
- Keep the spaces indicated by arrows from wall, ceiling, fence or other obstacles.
- Do not place any obstacles which may cause a short circuit of the discharged air.
- If piping length is over 7.5 m, additional refrigerant should be added as shown in the table.

Model	Piping size		Rated Length (m)	Max Elevation (m)	Max. Piping Length (m)	Additional Refrigerant (g/m)
	Gas	Liquid				
V28EK	5/8"	1/4"	5	20	30	30

Example: For V28EK

If the unit is installed at a 10m distance, the quality of additional refrigerant should be 75g $(10 - 7.5)m \times 30g/m = 75g$

10.2. Indoor/Outdoor Unit Installation Diagram

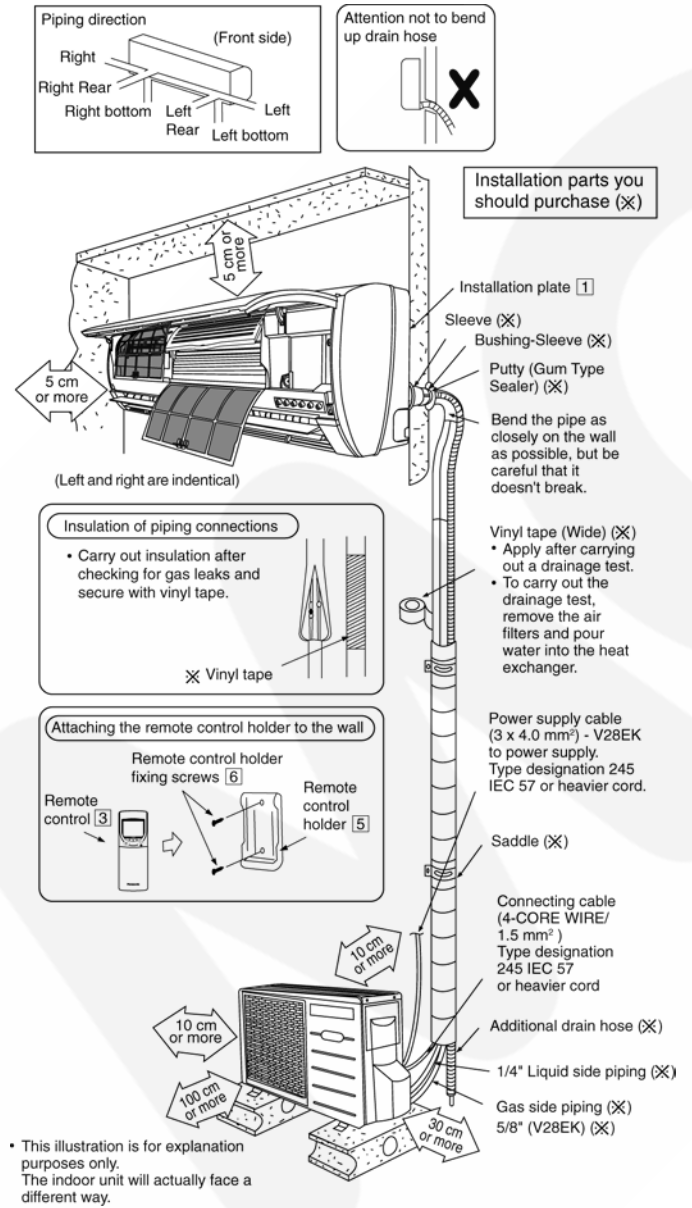

10.3. Indoor Unit

10.3.1. HOW TO FIX INSTALLATION PLATE

The mounting wall is strong and solid enough to prevent it from the vibration.

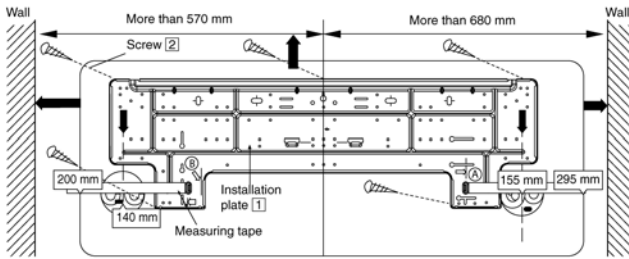

The centre of installation plate should be at more than 680 mm at right and 570 mm at left of the wall.

The distance from installation plate edge to ceiling should more than 73 mm.

From installation plate left edge to unit's left side is 20 mm.

From installation plate right edge to unit's right is 130 mm.

- ⓑ : For left side piping, piping connection for liquid should be about 155 mm from this line.
 : For left side piping, piping connection for gas should be about 190 mm from this line.
 : For left side piping, piping connection cable should be about 1100 mm from this line.

- Mount the installation plate on the wall with 5 screws or more.
 (If mounting the unit on the concrete wall, consider using anchor bolts.)
 - Always mount the installation plate horizontally by aligning the marking-off line with the thread and using a level gauge.
- Drill the piping plate hole with $\varnothing 70$ mm hole-core drill.
 - Line according to the arrows marked on the lower left and right side of the installation plate. The meeting point of the extended line is the centre of the hole. Another method is by putting measuring tape at position as shown in the diagram above. The hole centre is obtained by measuring the distance namely 140 mm and 155 mm for left and right hole respectively.
 - Drill the piping hole at either the right or the left and the hole should be slightly slanted to the outdoor side.

10.3.2. TO DRILL A HOLE IN THE WALL AND INSTALL A SLEEVE OF PIPING

- Insert the piping sleeve to the hole.
- Fix the bushing to the sleeve.
- Cut the sleeve until it extrudes about 15 mm from the wall.

Caution

When the wall is hollow, please be sure to use the sleeve for tube ass'y to prevent dangers caused by mice biting the connecting cable.

- Finish by sealing the sleeve with putty or caulking compound at the final stage.

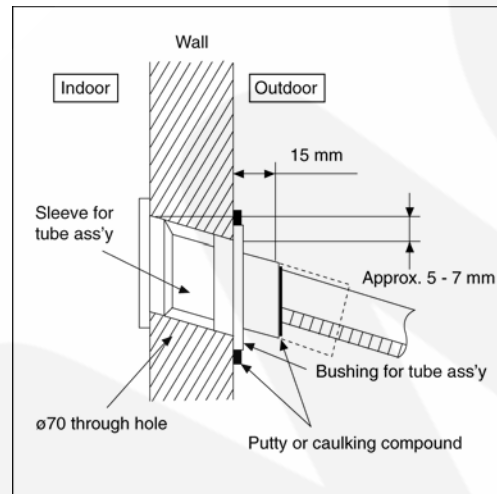

10.3.3. INDOOR UNIT INSTALLATION

1. For the right rear piping

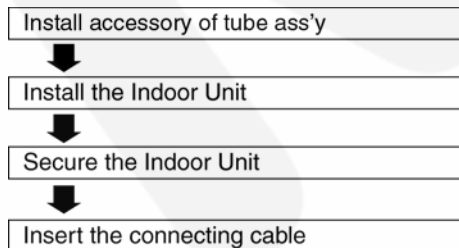

2. For the right and right bottom piping

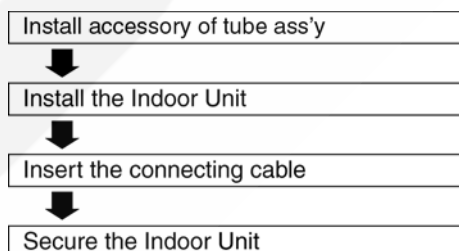

3. For the embedded piping

- Replace the drain hose
- ↓
- Bend the embedded piping
 - Use a spring bender or equivalent to bend the piping so that the piping is not crushed.
- ↓
- Install the Indoor Unit
- ↓
- Cut and flare the embedded piping
 - When determining the dimensions of the piping, slide the unit all the way to the left on the installation plate.
 - Refer to the section "Cutting and flaring the piping".
- ↓
- Pull the connecting cable into Indoor Unit
 - The inside and outside connecting cable can be connected without removing the front grille.
- ↓
- Connect the piping
 - Please refer to "Connecting the piping" column in outdoor unit section. (Below steps are done after connecting the outdoor piping and gas-leakage confirmation.)
- ↓
- Insulate and finish the piping
 - Please refer to "Piping and finishing" column of outdoor section and "Insulation of piping connections" column as mentioned in Indoor/Outdoor Unit Installation.
- ↓
- Secure the Indoor Unit

Install accessory of tube ass'y

1. Remove chassis back particular piece.

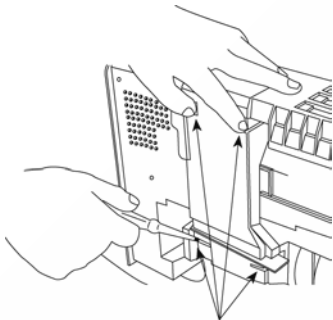

Release 4 position hooks

2. Connect tube ass'y 7 to gas side piping. Liquid side piping need to pull out to joint tube ass'y.

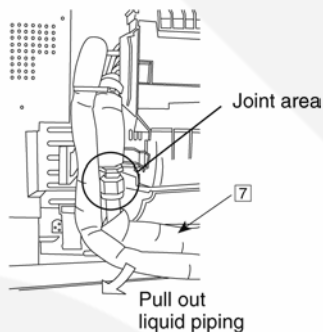

3. Set the piping direction.

(For bottom piping, need to perform cutting and flaring process.)

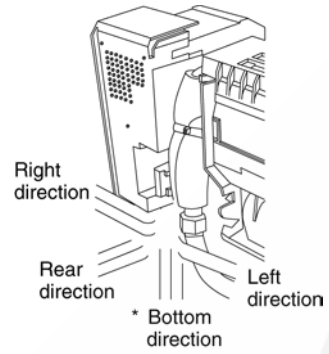

4. Use 2 spanner to tighten the nut. (tighten torque 65 N•m)

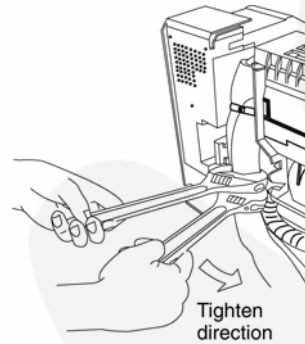

5. Check gas leakage at joint area.

6. Cover the open tubing with the foam and bind it by band 8 .

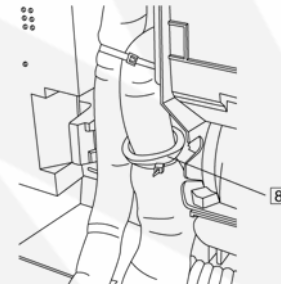

7. Close back the chassis back piece.

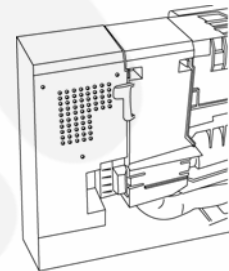

Cutting and flaring for bottom piping direction

1. Cut tube ass'y at 2 positions as below.

Union nut

(40 mm)

(100 mm)

Cut at 2 positions

2. After cut rejoin back union nut to tube ass'y.

3. Perform flaring process at end of tube ass'y.

Flaring process

Make sure this area is outside of chassis after connection

Pull out the piping and drain hose

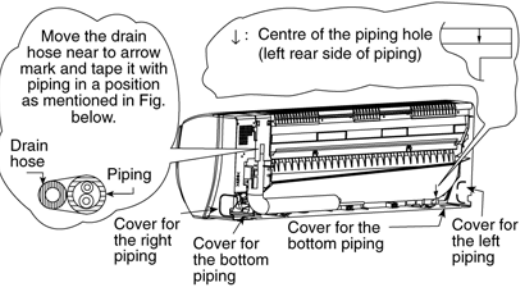

How to keep the cover

In case of the cover is cut, keep the cover at the rear of chassis as shown in the illustration for future reinstallation.

(Left, right and 2 bottom covers for piping.)

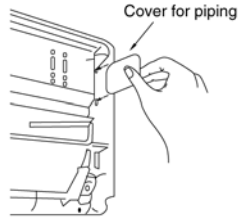

Insert the connecting cable

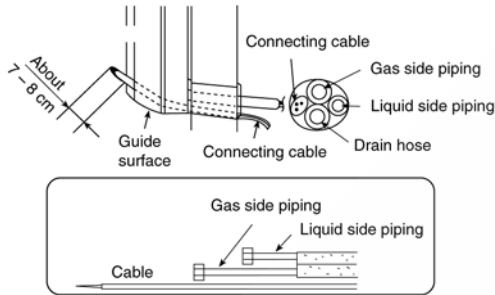

Exchange the drain hose and the cap

Rear view for left piping installation

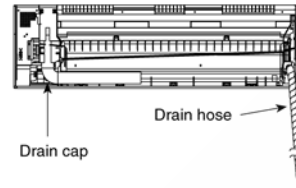

Install the indoor unit

Hook the indoor unit onto the upper portion of installation plate. (Engage the indoor unit with the upper edge of the installation plate). Ensure the hooks are properly seated on the installation plate by moving it in left and right.

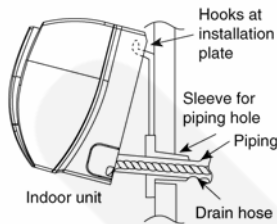

Secure the Indoor Unit

1. Press the lower left and right side of the unit against the installation plate until hooks engages with their slot (sound click).

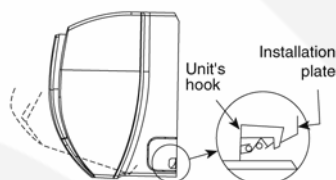

To take out the unit, push the **PUSH** marking at the bottom unit, and pull it slightly towards you to disengage the hooks from the unit.



How to pull the piping and drain hose out, in case of the embedded piping.

Apply putty or caulking material to seal the wall opening

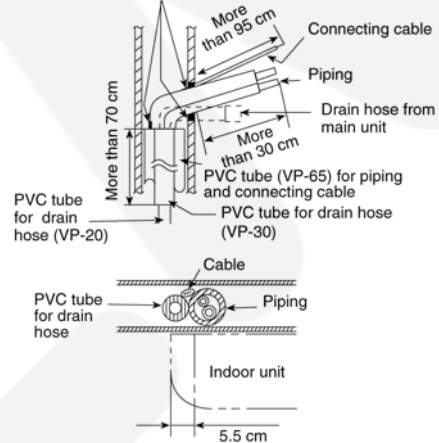

In case of left piping how to insert the connecting cable and drain hose.

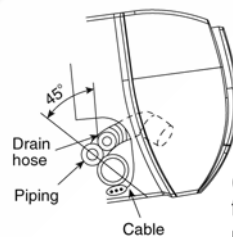







(For the right piping, follow the same procedure)

(This can be used for left rear piping and left bottom piping also.)

10.3.4. CONNECT THE CABLE TO THE INDOOR UNIT

1. The inside and outside connecting cable can be connected without removing the front grille.
2. Connecting cable between indoor unit and outdoor unit shall be approved polychloroprene sheathed $4 \times 1.5 \text{ mm}^2$ flexible cord, type designation 245 IEC 57 or heavier cord.
 - Ensure the color of wires of outdoor unit and the terminal Nos. are the same to the indoor's respectively.

Terminals on the indoor unit		1	2	3
Colour of wires				
Terminals on the outdoor unit		1	2	3

- Secure the cable onto the control board with the holder (clammer).
- Earth lead wire shall be longer than the other lead wires as shown in the figure for the electrical safety in case of the slipping out of the cord from the anchorage.

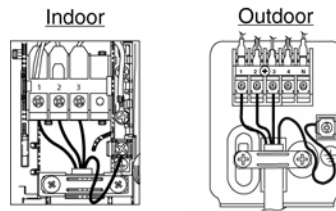

10.4. Outdoor Unit

10.4.1. INSTALL THE OUTDOOR UNIT

- After selecting the best location, start installation according to Indoor/Outdoor Unit Installation Diagram.
- 1. Fix the unit on concrete or rigid frame firmly and horizontally by bolt nut ($\phi 10$ mm).
- 2. When installing at roof, please consider strong wind and earthquake. Please fasten the installation stand firmly with bolt or nails.

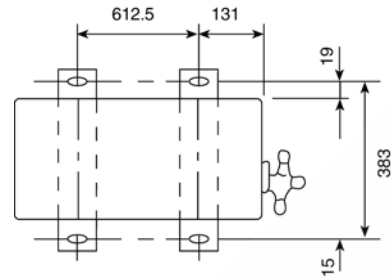

10.4.2. CONNECTING THE PIPING

Connecting The Piping To Indoor Unit

Please make flare after inserting flare nut (locate at joint portion of tube assembly) onto the copper pipe (in case of using long piping).

Connect the piping

- Align the center of piping and sufficiently tighten the flare nut with fingers.
- Further tighten the flare nut with torque wrench in specified torque as stated in the table.

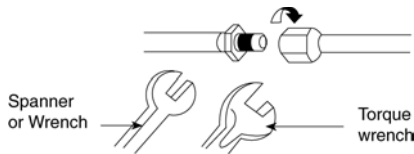

Model	Piping size (Torque)	
	Gas	Liquid
V28EK	5/8" [65 N•m]	1/4" [18 N•m]

Connecting The Piping To Outdoor Unit

Decide piping length and then cut by using pipe cutter. Remove burrs from cut edge. Make flare after inserting the flare nut (locate at valve) onto the copper pipe.

Align center of piping to valves and then tighten with torque wrench to the specified torque as stated in the table.

CUTTING AND FLARING THE PIPING

1. Please cut using pipe cutter and then remove the burrs.
2. Remove the burrs by using reamer. If burrs is not removed, gas leakage may be caused. Turn the piping end down to avoid the metal powder entering the pipe.
3. Please make flare after inserting the flare nut onto the copper pipes.

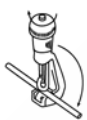

1. To cut

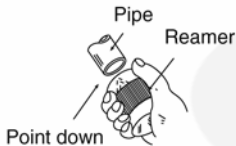

2. To remove burrs



3. To flare

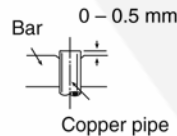

Copper pipe

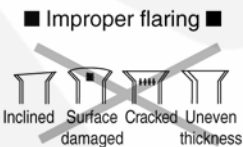

When properly flared, the internal surface of the flare will evenly shine and be of even thickness. Since the flare part comes into contact with the connections, carefully check the flare finish.

10.4.3. EVACUATION OF THE EQUIPMENT

WHEN INSTALLING AN AIR CONDITIONER, BE SURE TO EVACUATE THE AIR INSIDE THE INDOOR UNIT AND PIPES in the following procedure.

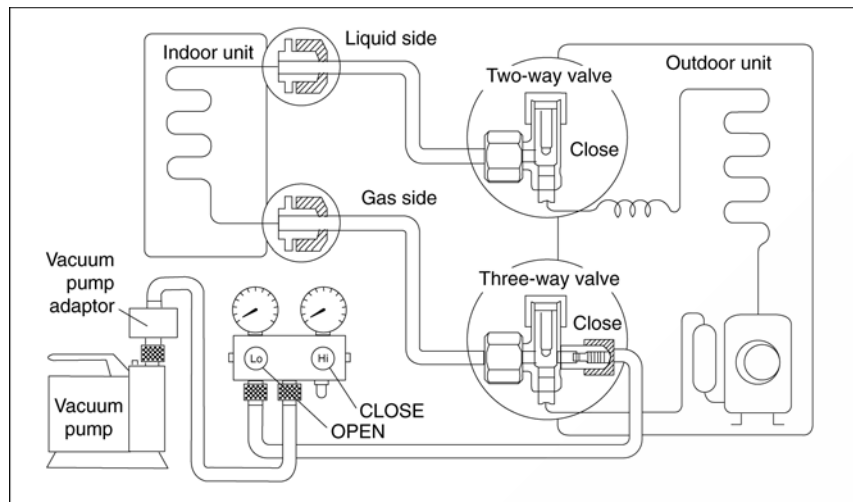

1. Connect a charging hose with a push pin to the Low side of a charging set and the service port of the 3-way valve.
 - Be sure to connect the end of the charging hose with the push pin to the service port.
2. Connect the center hose of the charging set to a vacuum pump with check valve, or vacuum pump and vacuum pump adaptor.
3. Turn on the power switch of the vacuum pump and make sure that the needle in the gauge moves from 0 cmHg (0 MPa) to -76 cmHg (-0.1 MPa). Then evacuate the air approximately ten minutes.
4. Close the Low side valve of the charging set and turn off the vacuum pump. Make sure that the needle in the gauge does not move after approximately five minutes.

Note: BE SURE TO FOLLOW THIS PROCEDURE IN ORDER TO AVOID REFRIGERANT GAS LEAKAGE.
5. Disconnect the charging hose from the vacuum pump and from the service port of the 3-way valve.
6. Tighten the service port caps of the 3-way valve at a torque of 18 N•m with a torque wrench.
7. Remove the valve caps of both of the 2-way valve and 3-way valve. Position both of the valves to "OPEN" using a hexagonal wrench (4 mm).
8. Mount valve caps onto the 2-way valve and the 3-way valve.
 - Be sure to check for gas leakage.

CAUTION

- If gauge needle does not move from 0 cmHg (0 MPa) to -76 cmHg (-0.1 MPa), in step ③ above take the following measure:
- If the leak stops when the piping connections are tightened further, continue working from step ③.
- If the leak does not stop when the connections are retightened, repair the location of leak.
- Do not release refrigerant during piping work for installation and reinstallation. Take care of the liquid refrigerant, it may cause frostbite.

10.4.4. CONNECT THE CABLE TO THE OUTDOOR UNIT

(FOR DETAIL REFER TO WIRING DIAGRAM AT UNIT)

1. Remove the control board cover from the unit by loosening the screw.
2. Connecting cable between indoor unit and outdoor unit shall be approved polychloroprene sheathed $4 \times 1.5 \text{ mm}^2$ flexible cord, type designation 245 IEC 57 or heavier cord.

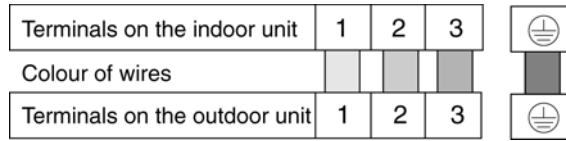

3. Secure the cable onto the control board with the holder (clammer).
4. Cable connection to the power supply (220-240V, 50Hz) through knife switch (Disconnecting means).
 - Connect the approved polychloroprene sheathed power supply cable $3 \times 4.0 \text{ mm}^2$ (V28EK), type designation 245 IEC 57 or heavier cord to the terminal board, and connect the other end of the cable to knife switch (Disconnecting means).

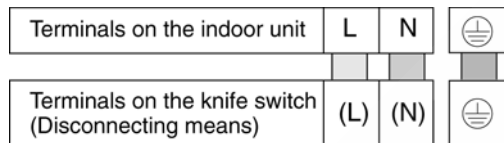

Note: Knife switch (Disconnecting means) should have minimum 3.5 mm contact gap.

- Secure the cable onto the control board with the holder (clammer).

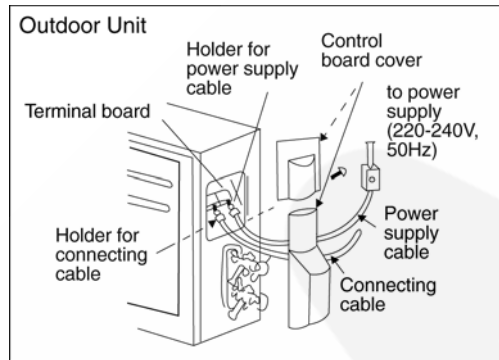

11 Operation And Control

11.1. Cooling Operation

- Cooling operation can be set using remote control.
- This operation is applied to cool down the room temperature reaches the setting temperature set on the remote control.
- The remote control setting temperature, which takes the reading of intake air temperature sensor, can be adjusted from 16°C to 30°C.
- During cooling operation, the compressor will stop running and restart as shown in below figure.

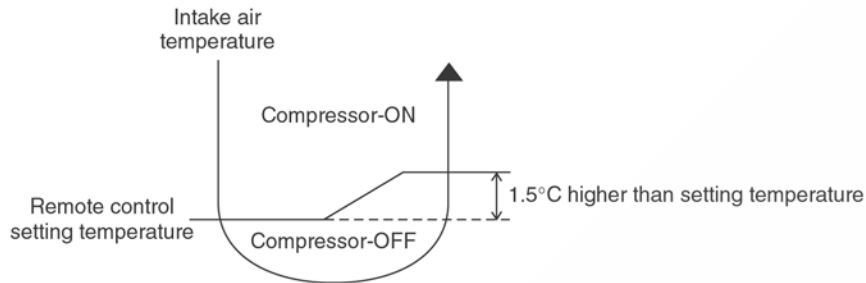

11.1.1. Cooling Operation Time Diagram

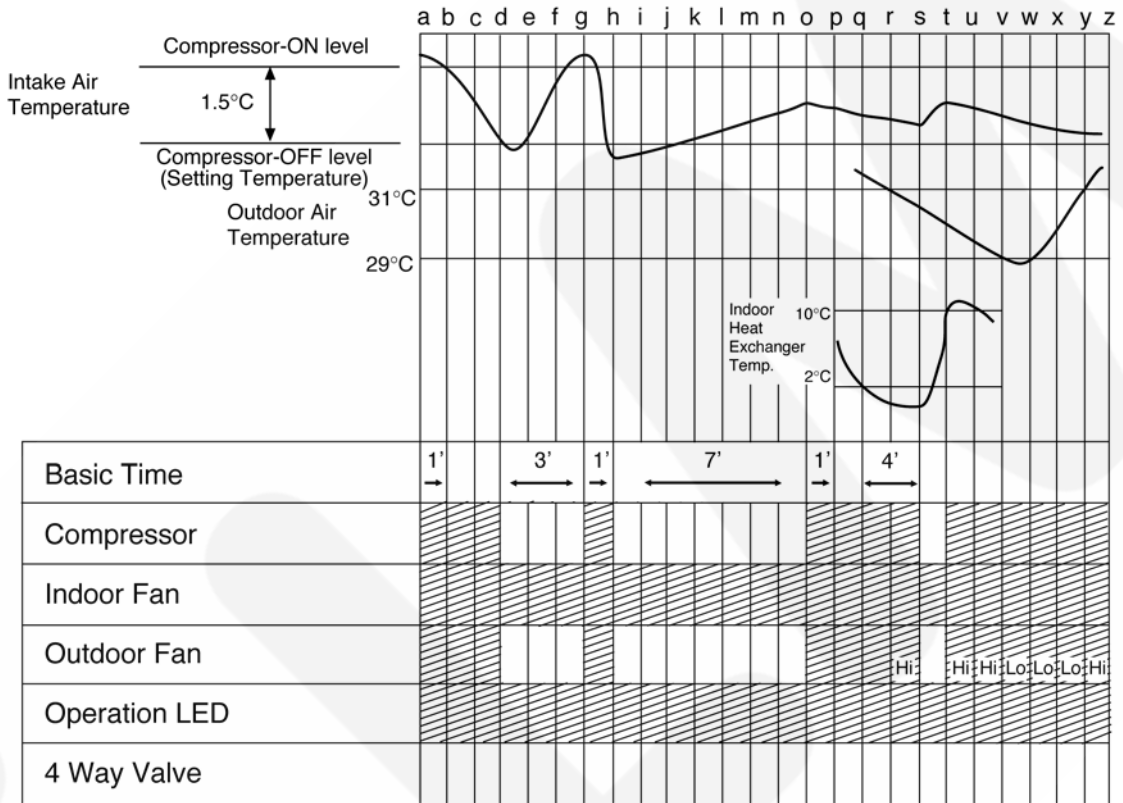

<Description of operation>

- d – g : Time Delay Safety Control (waiting for 3 minutes)
- g – h : 60 sec. Forced Operation
- h – o : 7 min. Time Save Control
- q – t : Anti Freezing Control
- v – y : Outdoor Fan Control

 Operation
 Stop

11.2. Soft Dry Operation

- Soft Dry operation can be set using remote control.
- Soft Dry operation is applied to dehumidify and to perform a gentle cooling to the room.
- This operation starts when the intake air temperature sensor reaches the setting temperature on the remote control.
- When operation begins, Soft Dry will be switched "ON" for a maximum 10 minutes, then Soft Dry operation will be turned "OFF" for a minimum 6 minutes. After that, the Soft Dry operation will be "ON" and "OFF" based on the setting temperature as shown in below figure.
- However after 3 minutes of compressor off, during Soft Dry "OFF" (within 6 minutes Soft Dry restart control), the indoor unit will start to operate at normal Cooling mode if the intake temperature is higher than Cooling "ON" point.

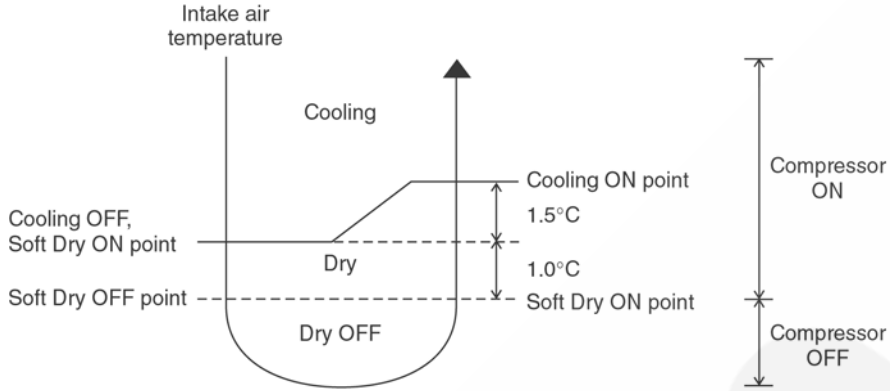

11.2.1. Soft Dry Operation Time Diagram

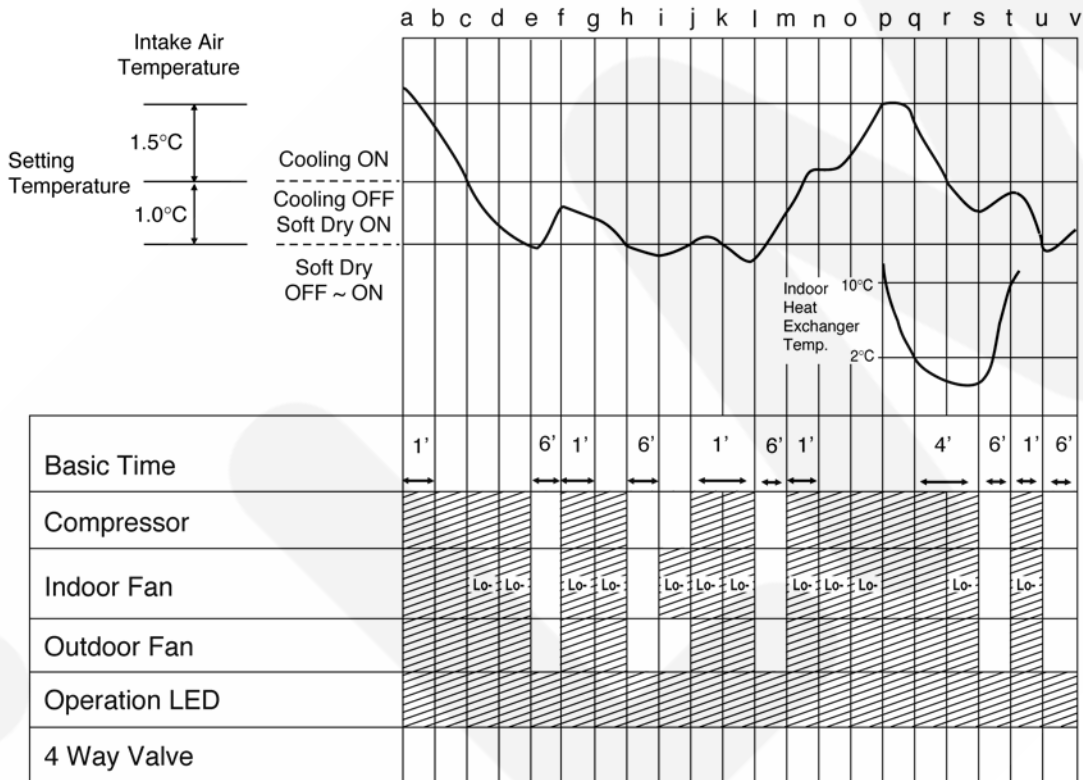

<Description of operation>

- a - c, p - r : Cooling Operation
- c - p : Soft Dry Operation
- e - f : Soft Dry OFF
- j - l : 60 sec. Forced Operation
- q - t : Anti Freezing Control

- Operation
- Stop

11.3. Automatic Operation

- Automatic operation can be set using remote control.
- This operation starts to operate with indoor fan at SLo speed for 20 seconds to judge the intake air temperature.
- After judged the temperature, the operation mode is determined by referring to the below standard.

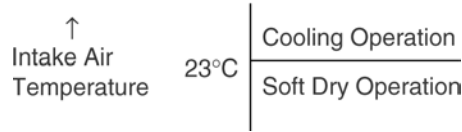

- Then, the unit start to operate at determined operation mode, until it is switched off using remote control, with the setting temperature as shown in below table.

	Setting Temperature (Standard)
Cooling Operation	25°C
Soft Dry Operation	22°C

- The setting temperature for all the operations can be changed one level up or one level down from the standard temperature as shown in below table by pressing on the temperature up or temperature down button at remote control.

Operation	Hi	(Standard)	Lo
	(+2°C)	(±0°C)	(-2°C)
Cooling	27°C	25°C	23°C
Soft Dry	24°C	22°C	20°C

- The operation mode judging temperature and standard setting temperature can be increased by 2°C permanently, by open the circuit of JX1 at indoor electronic controller.

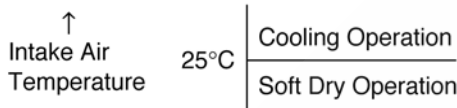

	Setting Temperature (Standard)
Cooling Operation	27°C
Soft Dry Operation	24°C

11.4. Operation Control

(For 11.4.1 to 11.4.7 information applies only to Cooling and Soft Dry Operation)

11.4.1. Restart Control (Time Delay Safety Control)

- When the thermo-off temperature (temperature which compressor stops to operate) is reached during:-
 - Cooling operation - the compressor stops for 3 minutes (minimum) before resume operation.
 - Soft Dry operation - the compressor stops for 6 minutes (minimum) before resume operation.
- If the operation is stopped by the remote control, the compressor will not turn on within 3 minutes from the moment operation stop, although the unit is turn on again within the period.
- This phenomenon is to balance the pressure inside the refrigerant cycle.

11.4.2. 60 Seconds Forced Operation

- Once the air conditioner is turned on, the compressor will not stop within 60 seconds in a normal operation although the intake air temperature has reached the thermo-off temperature. However, force stop by pressing the OFF/ON operation button at the remote control is permitted.
- The reason for the compressor to force operate at minimum 60 seconds is to allow the refrigerant oil run in a full cycle and return back to the outdoor unit.

11.4.3. 7 Minutes Time Save Control

- The compressor will start automatically if it has stopped for 7 minutes and the intake air temperature falls between the compressor ON temperature (A) and compressor OFF temperature (B) during the period.
- This phenomenon is to reduce the built up humidity inside a room.

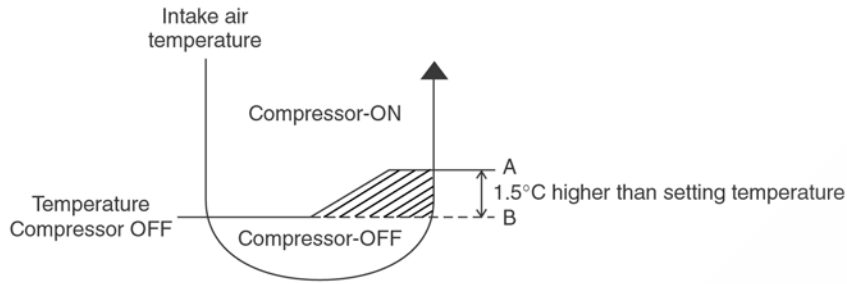

11.4.4. Freeze Prevention Control

- If the temperature of the indoor heat exchanger falls below 2°C continuously for 4 minutes or more, the compressor turns off. The fan speed setting remains the same.
- This phenomenon is to protect the indoor heat exchanger from freezing and to prevent higher volume of refrigerant in liquid form returning to the compressor.
- Compressor will restart again when the indoor heat exchanger temperature rises to 10°C (Recovery).
- Restart control (Time Delay Safety Control) will be applied in this Control if the recovery time is too short.

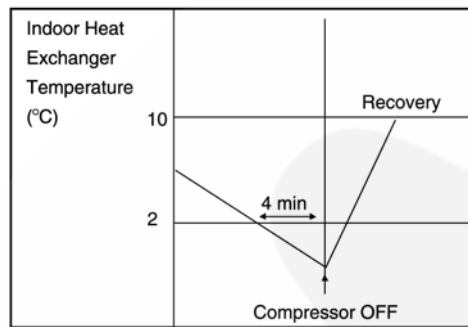

11.4.5. Compressor Reverse Rotation Protection Control

- If the compressor is operating continuously for 5 minutes or longer and the temperature difference between intake air and indoor heat exchanger is 2.5°C or less for continuous 2 minutes, compressor will stop and restart automatically.
- Time Delay Safety Control is activated before the compressor restart.



▲ T = Intake air temperature - Indoor heat exchanger temperature

- This is to prevent compressor from rotate reversely when there is an instantaneous power failure.

11.4.6. Starting Current Control

- When the compressor, outdoor fan motor and indoor fan motor are simultaneously started, the indoor fan motor will start to operate at 1.6 second later.
- The reason of the difference is to reduce the starting current flow.

11.4.7. Dew Prevention Control

- Purpose is to prevent dew formation on indoor unit air discharge area.
- The following conditions occur for 30 minutes continuously, dew prevention will activate:
 - Remote Control setting temperature is less than 25°C.
 - Compressor is on.
 - Cooling operation mode.

- Indoor fan motor operate at low fan speed or QLo.
- This control is cancelled immediately when above condition is changed.
- Dew prevention is control by:
 1. Lo fan speed
Lo fan is changed to Lo+ fan
 2. QLo fan speed

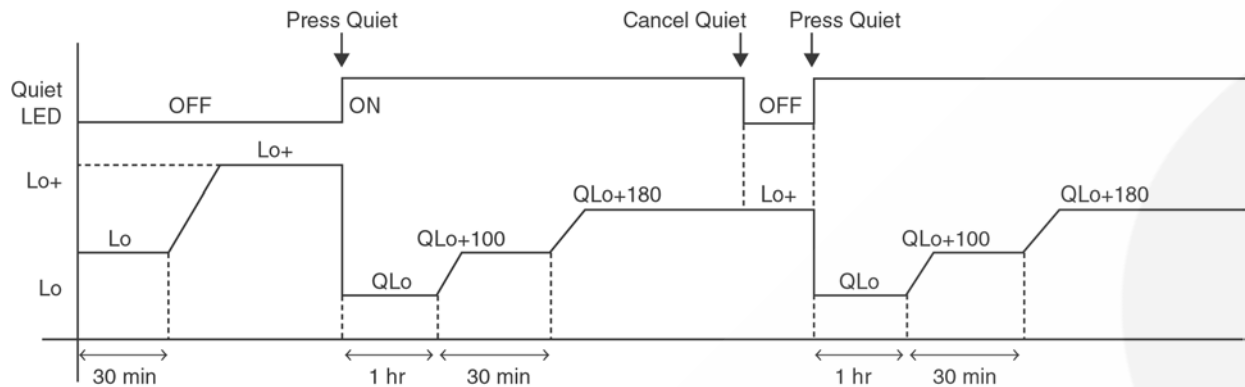

11.5. Indoor Fan Speed Control

- Indoor Fan Speed can be set using remote control.

11.5.1. Fan Speed Rotation Chart

Speed	CS-V28EKE
Cool, Dry	
S Hi	1760
Hi	1720
Me	1590
Lo+	1500
Lo	1410
Lo-	1200
S Lo	960
Q Hi	1620
Q Me	1480
Q Lo	1310

11.5.2. Automatic Fan Speed Control

- When set to Auto Fan Speed, the fan speed is adjusted between maximum and minimum setting as shown in the table.
 - Fan speed rotates in the range of Hi, Me and Lo-.
 - Deodorizing Control will be activated.

Tap			S Hi	Hi	Me	Lo+	Lo	Lo-	SLo	SSLo	Stop
Cooling	Normal	Manual	Hi	○							
			Me		○						
			Lo				○				
	Auto		○	○			○			○	
Powerful	Manual	○									
	Auto	○									
Soft Dry	Manual							○			○
	Auto							○			○
Auto Mode judgement									○		
Cooling	Quiet	Manual	QHi	(Hi)-100							
			QMe		(Me)-100						
			QLo				(Lo)-100				
Auto		(Hi)-100	(Me)-100			○				○	
Soft Dry	Quiet	Manual						○			○
		Auto						○			○
Ion	Manual		○	○		○					○
	Auto				○	○					○

- Auto Fan Speed during cooling operation:

- Indoor fan will rotate alternately between off and on as shown in below diagram.
- At the beginning of each compressor start operation, indoor fan will increase fan speed gradually for deodorizing purpose.
- For the first time the compressor operate, indoor fan will be switched to Hi fan speed from Lo- after 70 seconds from the start of compressor. This cause the room temperature to achieve the setting temperature quickly.
- During compressor stop, indoor fan will operate at Lo- for the beginning 20 seconds to prevent higher volume of refrigerant in liquid form returning to the compressor.
- After the compressor at turn off condition for 3 minutes, indoor fan will start to operate at Lo- to circulate the air in the room. This is to obtain the actual reading of the intake air temperature.
- When the compressor resume operation, indoor fan will operate at Me fan speed (after 70 seconds from the restart of compressor) to provide comfort and lesser noise environment.

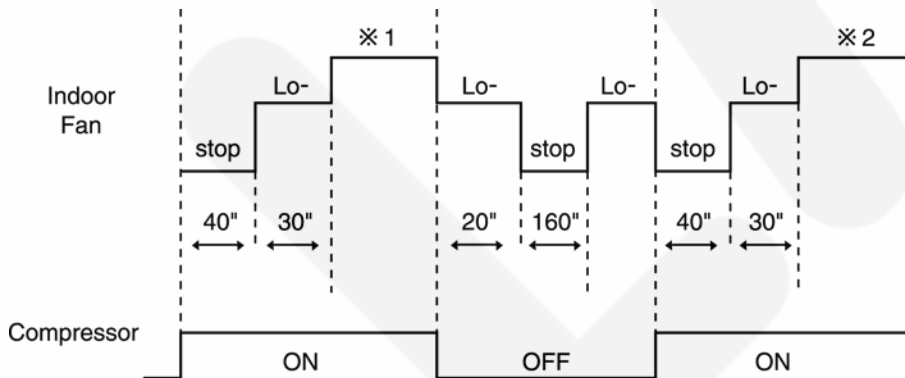

- ※ 1 Fan Speed is Hi until the compressor stops (when the room temperature reaches setting temperature).
- ※ 2 Fan Speed is Me after the compressor restarts.

- Auto Fan Speed during Soft Dry operation:
 1. Indoor fan will rotate alternately between off and Lo-.
 2. At the beginning of each compressor start operation, indoor fan will increase fan speed gradually for deodorizing purpose.
 3. When compressor at turn off condition for 6 minutes, indoor fan will start fan speed at Lo- to circulate the air in the room. This is to obtain the actual reading of intake air temperature.

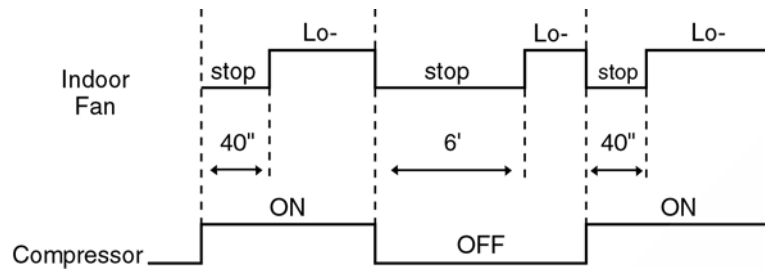

11.5.3. Manual Fan Speed Control

- Manual fan speed adjustment can be carried out by using the Fan Speed selection button at the remote control.
- There are 3 types of fan speed setting: Lo, Me, Hi.

11.6. Outdoor Fan Speed Control

- There are 2 speeds for outdoor fan motor, outdoor fan speed can be changed to Hi or Lo according to outdoor temperature (V28EK).
- When the air conditioner is turned on, the compressor and the outdoor fan will operate simultaneously.
- Likewise, both compressor and outdoor fan will stop at the same time if the unit is turned off.

11.7. Vertical Airflow Direction Control

11.7.1. Auto Control

(Cooling and Soft Dry Operation condition)

- When the vertical airflow direction is set to Auto using the remote control, the louver swings up and down as shown in the diagram.
- When stop operation using the remote control, the discharge vent is reset, and stop at the closing position.
- During Cooling operation or Soft Dry operation, indoor fan motor may stop to rotate at certain periods. At that condition, the louver will stop swinging and rest at the upper limit.
- During dew prevention control, Airflow Direction Auto-control angle change from 10°-38° to 10°-27° under Cooling and Soft Dry operation mode.

Cooling and Soft Dry Operation

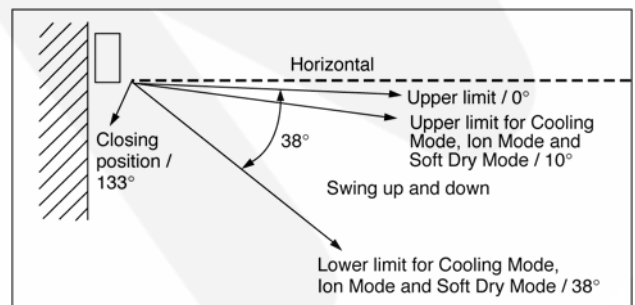

11.7.2. Manual Control

- When the vertical airflow direction is set to Manual using the remote control, the automatic airflow is released and the airflow direction louver move up and down in the range shown in the diagram.
- The louver can be adjusted by pressing the button to the desired louver position.
- When stop operation using the remote control, the discharge vent is reset, and stop at the closing position.
- During dew prevention control, Airflow Direction Manual control angle change from 10°, 14°, 18°, 22°, 27° to 10°, 13°, 16°, 19°, 22° under Cooling and Soft Dry operation mode.

Cooling and Soft Dry Operation

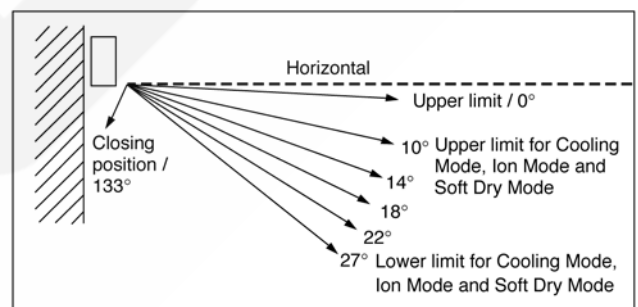

11.8. Horizontal Airflow Direction Control

11.8.1. Auto Control

- When the horizontal airflow direction is set to Auto using the remote control, the vanes swings left and right for Cooling and Soft Dry (0° - 44°) as shown in the diagram.
- When stop operation using the remote control, the vanes is reset, and stop at the reset position.
- During Cooling operation or Soft Dry operation, indoor fan motor may stop to rotate at certain periods. At that condition, the vanes will stop swinging and rest at 22° .
- During dew prevention control, Airflow Direction Auto-control angle change from 0° - 44° to 14° - 30° under Cooling and Soft Dry operation mode.

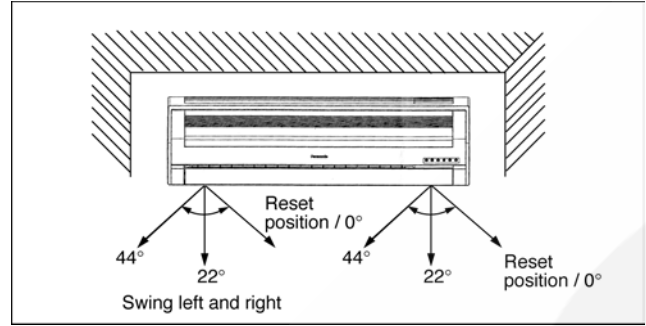

11.8.2. Manual Control

- When the horizontal airflow direction is set to Manual using the remote control, the automatic airflow is released and the airflow direction vane move left and right in the range shown in the diagram.
- The louver can be adjusted by pressing the button to the desired vane position.

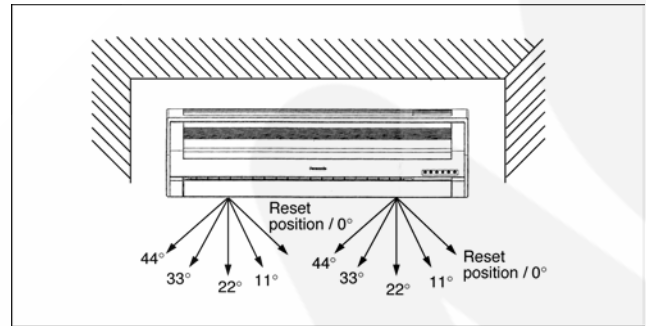

- When stop operation using the remote control, the vanes is reset, and stopped at reset position.
- During dew prevention control, Airflow Direction Manual control angle change from 0° , 11° , 22° , 33° , 44° to 14° , 18° , 22° , 26° , 30° under Cooling and Soft Dry operation mode.

11.9. Powerful Operation

- The Powerful operation is to achieve the setting temperature quickly.

(Cooling and Soft Dry Operation condition)

- When Powerful operation is set, the setting temperature will be automatically decreased 3°C internally against the present setting temperature (Lower temperature limit: 16°C).
- This operation automatically will be running under SHi Fan Speed (Cooling).
- Vertical Airflow Direction:-
 - In "Manual" setting, the vane will automatically shift down 10° lower than previous.
 - In "Auto" setting, the vane will automatically swing up and down. However the lower limit will be shifted 10° downward.
- Powerful operation stops when:-
 - Powerful operation has operate for 15 minutes.
 - Powerful button is pressed again.
 - Quiet button is pressed.
 - Stopped by OFF/ON operation button.
 - Timer OFF activates.
 - Operating mode is changed.

11.10. Quiet Operation

- The Quiet operation is to provide quiet cooling/heating operation condition compare to normal operation.

(Cooling and Soft Dry Operation condition)

- Once the Quiet Mode is set at the remote control, Quiet Mode LED illuminates. The sound level will reduce either around 2 dB(A) for Lo fan speed or 3 dB(A) for Hi/Me fan speed against the present sound level operation.
- Dew formation become severe at Quiet Lo cool, therefore Quiet Lo cool is operated only 1hr 30 min (1hr QLo, 30 min QLo + 100 rpm). After that, it goes back to QLo+180rpm (However Quiet LED remains on).

- Manual Fan Speed:-
 - RPM control during Lo cool

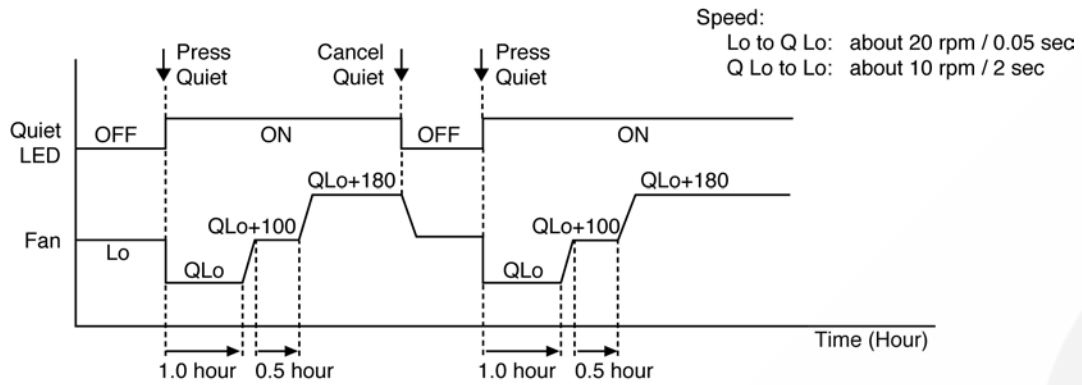

- RPM control during Hi & Me cool

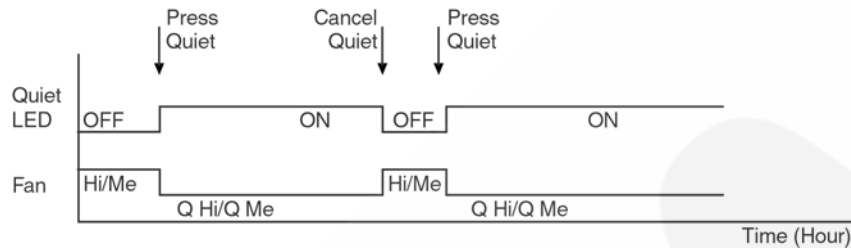

- Auto Fan Speed:-

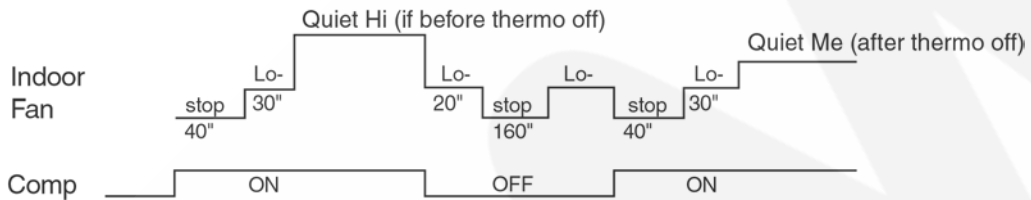

- Quiet operation stops when:-
 - Quiet/Powerful button is pressed again.
 - Stopped by OFF/ON operation button.
 - Timer OFF activates.

11.11. Ionizer Operation

- The ionizer operation is to provide fresh air effect to user by producing minus ion in discharged air.

11.11.1. Operation Control

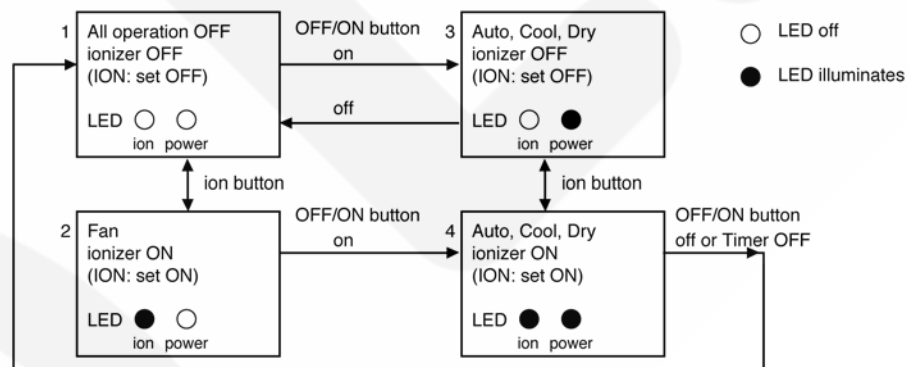

1. Ionizer individual operation

- a. When air-conditioner unit is at "OFF" condition (standby) and ION operation button at the remote control is pressed, the ionizer and indoor fan operations will turn on. Only ION LED will illuminate. Power LED maintain off. (1 → 2)
- b. Ionizer individual operation can be turned off by pressing the ION button again. (2 → 1)
- c. Fan speed can be adjusted later by customer during this operation.

Indoor fan mode	Fan speed
Manual	Hi, Me, CLo
Auto	between Lo+ & Lo at the pattern shown below

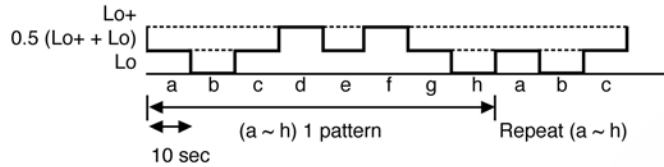

- d. Vertical airflow direction can be adjusted using remote control during Ionizer individual operation.
- e. During Ionizer individual operation, operated mode (Auto, Cool, Soft Dry) can be activated by turning on the OFF/ON operation button. (2 → 4)
- f. If power failure occur during Ionizer individual operation, after power resume, Ionizer operation will be activated immediately.
- g. When the Ionizer circuit feedback process error occur for 24 times (about 11hr 30 min.), Ionizer and Fan operations will turn off with ION LED blinks continuously.
(For details, please refer to Ionizer Error detection control)

2. Operation mode & Ionizer operation.

- a. When air-conditioner unit is at "ON" condition and ION operation button at the remote control is pressed, the Ionizer operation will turn on. ION and Power LED will illuminate. (3 → 4)
- b. Ionizer operation stops when:
 - ION operation button is press again.
 - Stopped by OFF/ON operation button.
 - Timer OFF activates.
 - Ionizer circuit feedback signal shows error.
- c. Ionizer operation status is not memorized when the air conditioner has been switched off. The air-conditioner will operate without ionizer operation when it is turned on again. However, if power failure occurs during Ionizer operation together with Cooling operation, air-conditioner will start to operate at Cooling operation with Ionizer operation when the power is resumed.

11.11.2. Error Detection Control

- The error detection control is to inform user that error occurs at ionizer system and repairing job will be needed.
- There are two types of error detection control:
 - a. When Ionizer is ON
 - If ionizer feedback = Lo for 24 times within 11hr 30min, ION LED blinks continuously.
 - b. When ionizer is OFF
 - If ionizer feedback = Hi, ION LED blinks continuously.
- During ionizer at breakdown condition, if ionizer feedback voltage = Lo (become normal), ION LED will stop blinking.
- The error detection control can be reset by:
 - i) Pressing the OFF/ON operation button to switch the operation OFF.
 - ii) Pressing the Auto Operation button to force the operation OFF.
 - iii) Setting the OFF Timer to stop the operation (Not applicable when ionizer is OFF).

11.12. Timer Control

- There are 2 types of timer, ON and OFF timer.
- Both ON and OFF timer can be set by pressing ON or OFF button respectively.
- By pressing ON/OFF operation button, ON Timer or OFF Timer will not be cancelled.
- To cancel the previous timer setting, press CANCEL button.
- To activate the previous timer setting, press SET button once again.
- If main power supply is switched off, the timer setting will be cancelled.

11.12.1. ON Timer

- When ON Timer is set by using the remote control, the unit will start to operate slightly before the set time, so that the room will reach nearly to the set temperature by the set time.
- For Cooling and Soft Dry operation, the operation will start 15 minutes before the set time.
- For Automatic operation, the indoor fan will operate at SLo speed for 20 seconds, 30 minutes before the set time to detect the intake air temperature to determine the operation mode. The operation indication lamp will blink at this time.

11.12.2. OFF Timer

- When OFF Timer is set by using the remote control, the unit will stop operate according to the desired setting.

11.13. Random Auto Restart Control

- If there is a power failure during operation, the air conditioner will automatically restart after 3 to 4 minutes when the power is resumed.
- It will start with previous operation mode and airflow direction.
- If there are more than one air conditioner unit in operation and power failure occur, restart time for each unit to operate will be decided randomly using 4 parameters:- intake air temperature, setting temperature, fan speed and air swing louver position.
- This Random Auto Restart Control is not available when Timer is set.
- This control can be omitted by open the circuit of JX2. (Refer Indoor Printed Circuit Board)

11.14. Remote Control Signal Receiving Sound

- Long beep sound will be heard when:-
 - Stopping the air conditioner using OFF/ON operation button.
 - Stopping the Quiet Mode.
 - Stopping the Powerful Mode.
 - Stopping the Ion Mode.
- Short beep sound will be heard for others setting.

12 Servicing Mode

12.1. Auto OFF/ON Button

- The “Auto OFF/ON Button” (behind the front grille) is used to operate the air conditioner if remote control is misplaced or malfunctioning.
- Forced cooling operation is possible by pressing the “Auto OFF/ON Button” for more than 5s where “beep” sound is heard then release the button.
- User able to select remote control transmission code and toggle remote control signal receiving sound under various setting mode.
- To enter various setting mode:
 - Press the “Auto OFF/ON Button” continuously for 5s (“beep” sound is heard) and release.
 - Within 20s, press the “Auto OFF/ON Button” continuously for 5s again (2 “beep” sound is heard) and release.
 - Various setting mode has limit up to 20s. Then return to normal operation.

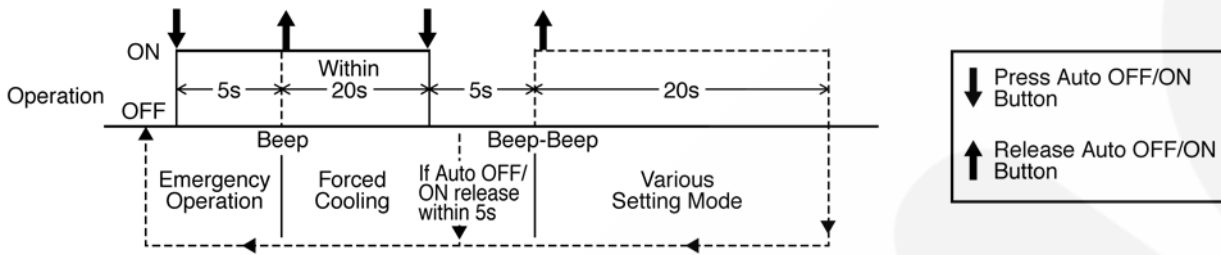

12.1.1. Toggle Remote Control Signal Receiving Sound

- Under various setting mode, press the “Auto OFF/ON Button” to toggle the remote control sound.
 - Short “beep”: Turn ON remote control signal receiving sound.
 - Long “beep”: Turn OFF remote control signal receiving sound.
- After “Auto OFF/ON Button” is pressed, the 20s counter for various setting mode is restarted.

12.1.2. Select Remote Control Transmission Code

- There are 4 types of remote control transmission code could be selected and stored in EEPROM of indoor unit. The indoor unit will only operate when received signal with same transmission code from remote control. This could prevent signal interference when there are 2 or more indoor unit installed nearby together.
- To change remote control transmission code, short or open jumpers at the remote control printed circuit board.

Remote Control Printed Circuit Board	Transmission Code Combination		
	J - A	J - B	Remote Control No.
	Short	Open	A (Default)
	Open	Open	B
	Short	Short	C
	Open	Short	D

- Under various setting mode, after select the transmission code combination of remote control, press any button of remote control to transmit a signal to indoor unit. The transmission code will be stored in EEPROM.
- After signal is received, the various setting mode is cancelled and return to normal operation.

TIMER TABLE

Name		Time	Test Mode (When test point Short-circuited)	Remarks
Real Timer		1 hr.	1 min.	
		10 min.	10 sec.	
		1 min.	1 sec.	
Time Delay Safety Control		2 min. 58 sec.	0 sec.	
Forced Operation		60 sec.	0 sec.	
Time Save Control		7 min.	42 sec.	
Anti-Freezing		4 min.	0 sec.	
Auto Mode Judgement		25 sec.	0 sec.	
Soft Dry	OFF	6 min.	36 sec.	
	ON	10 min.	60 sec.	Soft Dry: 10 min. operation
Deodorizing Control	Cooling	40 sec.	4 sec.	
		70 sec.	7 sec.	
		20 sec.	2 sec.	
		180 sec.	18 sec.	
	Soft Dry	40 sec.	4 sec.	
		360 sec.	36 sec.	
Comp. Reverse Rotation Detection		5 min.	30 sec.	Comp. ON 5 min. and above
		2 min.	0 sec.	
Comp./ Fan Motor Delay Timer		1.6 sec.	0 sec.	
Powerful Mode Operation		15 min.	15 sec.	
Random Auto Restart Control		0 ~ 62 sec.	0 ~ 6.2 sec.	
Ion OFF Timer		30 min.	180 sec.	
Ion ON Timer		10 sec.	1 sec.	
Quiet operation timer		1 hr. 30 min.	9 sec.	

13 Troubleshooting Guide

13.1. Refrigeration Cycle System

In order to diagnose malfunctions, make sure that there are no electrical problems before inspecting the refrigeration cycle. Such problems include insufficient insulation, problem with the power source, malfunction of a compressor and a fan. The normal outlet air temperature and pressure of the refrigeration cycle depends on various conditions, the standard values for them are shown in the table on the right.

Normal Pressure and Outlet Air Temperature (Standard)

	Gas pressure Mpa (kg/cm ² G)	Outlet air temperature (°C)
Cooling Mode	0.9 ~ 1.2 (9 ~ 12)	10 ~ 16

* Condition: Indoor fan speed; High
Outdoor temperature 35°C

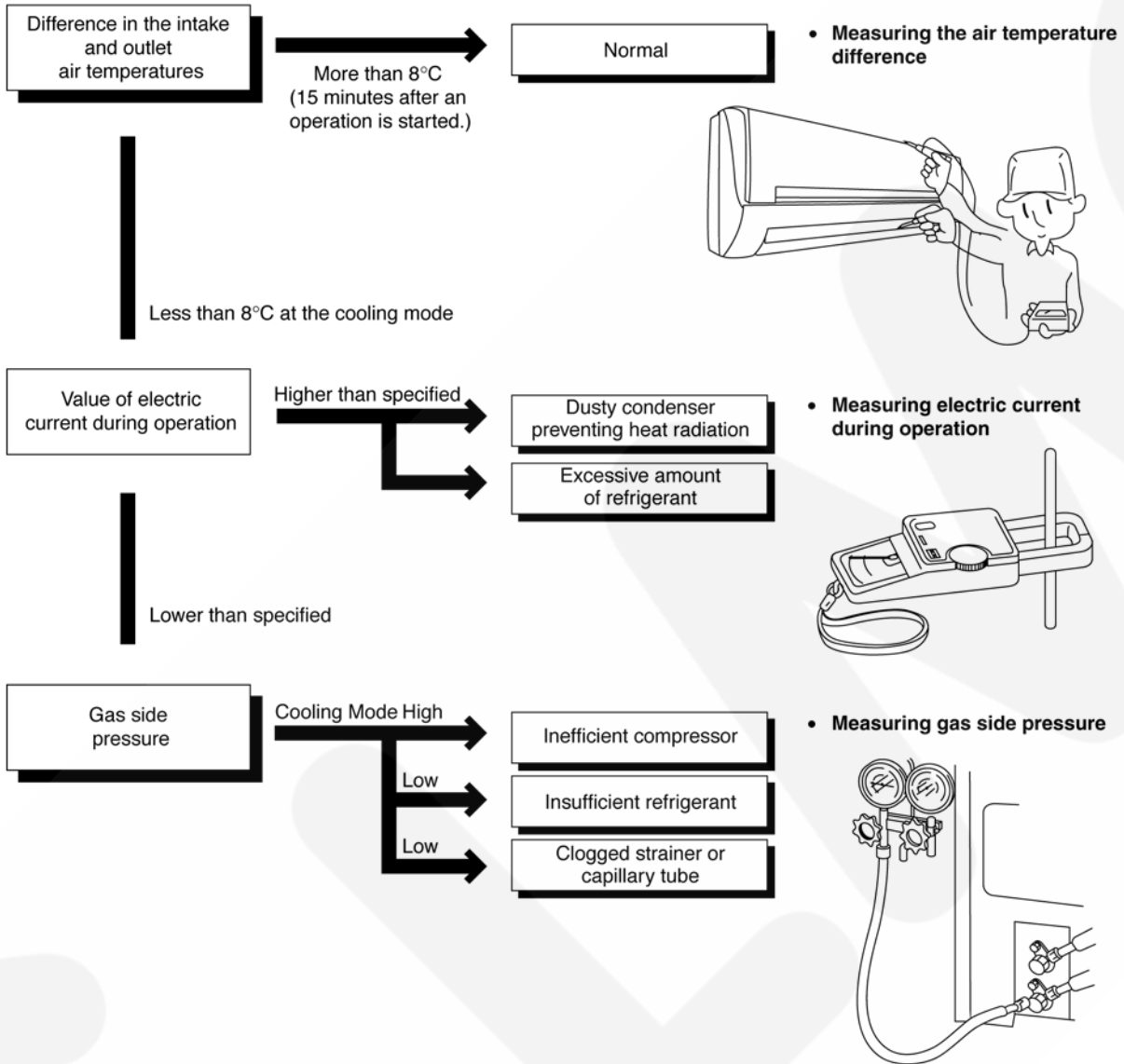

13.2. Relationship Between The Condition Of The Air Conditioner And Pressure And Electric Current

Condition of the air conditioner	Cooling Mode		
	Low Pressure	High Pressure	Electric current during operation
Insufficient refrigerant (gas leakage)	➔	➔	➔
Clogged capillary tube or Strainer	➔	➔	➔
Short circuit in the indoor unit	➔	➔	➔
Heat radiation deficiency of the outdoor unit	➔	➔	➔
Inefficient compression	➔	➔	➔

- Carry out the measurements of pressure, electric current, and temperature fifteen minutes after an operation is started.

13.3. Diagnosis Methods Of A Malfunction Of A Compressor And 4-way Valve

Nature of fault	Symptom
Insufficient compressing of a compressor	<ul style="list-style-type: none"> • Electric current during operation becomes approximately 20% lower than the normal value. • The discharge tube of the compressor becomes abnormally hot (normally 70 to 90°C). • The difference between high pressure and low pressure becomes almost zero.
Locked compressor	<ul style="list-style-type: none"> • Electric current reaches a high level abnormally, and the value exceeds the limit of an ammeter. In some cases, a breaker turns off. • The compressor has a humming sound.

14 Disassembly and Assembly Instructions

WARNING

High voltages are generated in the electrical parts area by the capacitor. Ensure that the capacitor has discharged sufficiently before proceeding with repair work. Failure to heed this caution may result in electric shocks.

14.1. Indoor Electronic Controllers, Cross Flow Fan and Indoor Fan Motor Removal Procedures

14.1.1. To remove the Front Grille

- Remove the Front Grille centre screw. (Fig. 1)
- Remove the 4 caps and 4 screws at the bottom of the Front Grille. (Fig. 1)
- Remove the Front Grille by releasing the 3 hooks at the top of the Front Grille. (Fig. 1)

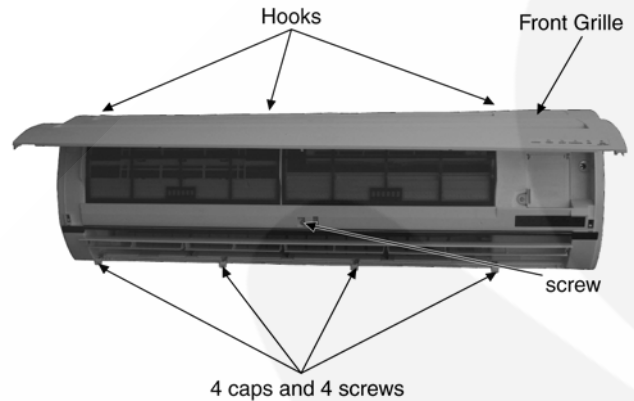

Fig. 1

- Unhook the tabs at the Control Board to remove the Control Board Cover. (Fig. 2)

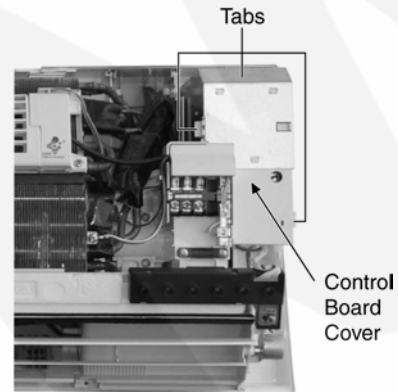

Fig. 2

14.1.2. To remove the Electronic Controller

- Release the 2 screws for the earth wire. (Fig. 3)
- Release the Terminal 1 (BLK) and Terminal 3 (BRW). (Fig. 3)
- Release the hooks that hold the Electronic Controller and pull out the Electronic Controller. (Fig. 3)

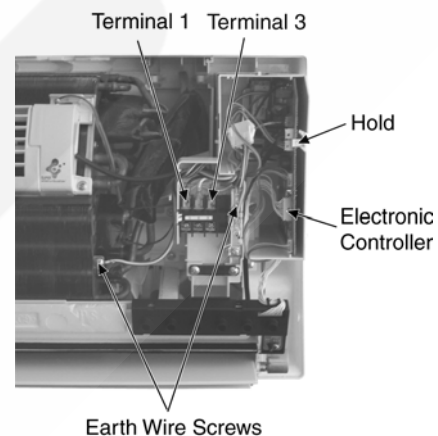

Fig. 3

- Release the CN-TH connector. (Fig. 4)
- Release the CN-ION connector. (Fig. 4)
- Release the CN-SONIC connector. (Fig. 4)
- Release the CN-STM1 connector. (Fig. 4)
- Release the CN-DISP connector. (Fig. 4)
- Release the CN-STM2 connector. (Fig. 4)
- Release the Terminal AC01 (WHT). (Fig. 4)
- Release the CN-FM connector. (Fig. 4)

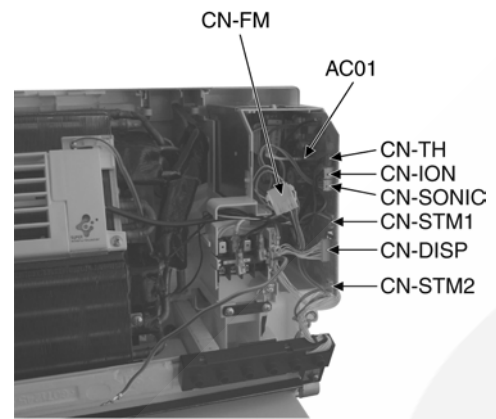

Fig. 4

14.1.3. To remove the Discharge Grille

- Pull out the Drain Hose (behind the Discharge Grille) from outlet to remove the Discharge Grille. (Fig. 5)

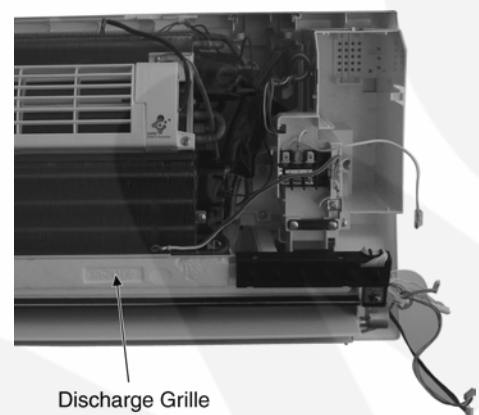

Fig. 5

14.1.4. To remove the Control Board

- Release the Ionizer by screw. (Fig. 6)
- Release the 4 screws Control Board Casing. (Fig. 6)

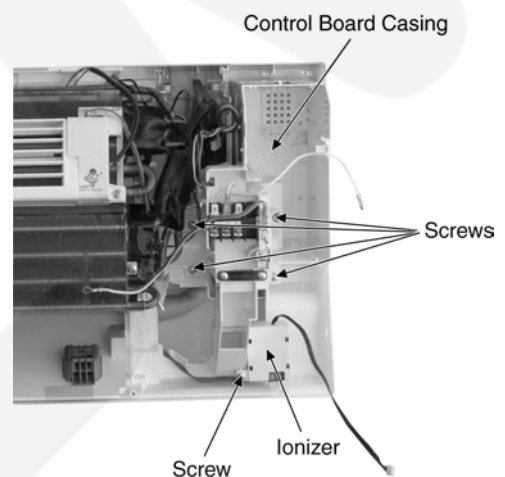

Fig. 6

14.1.5. To remove the Cross Flow Fan and Indoor Fan Motor

- Remove the screw at the Cross Flow Fan. (Fig. 7)

Reminder :-

To reinstall the Fan Motor, please adjust the connector location is positioned 45° with Fan Motor before fixing Control Board Casing. (Fig. 7)

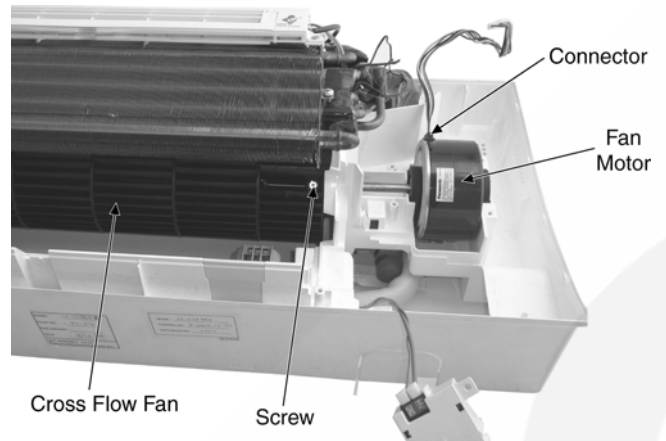

Fig. 7

- Remove the Bearing. (Fig. 8)
- Remove the screws at the left of the Evaporator. (Fig. 8)

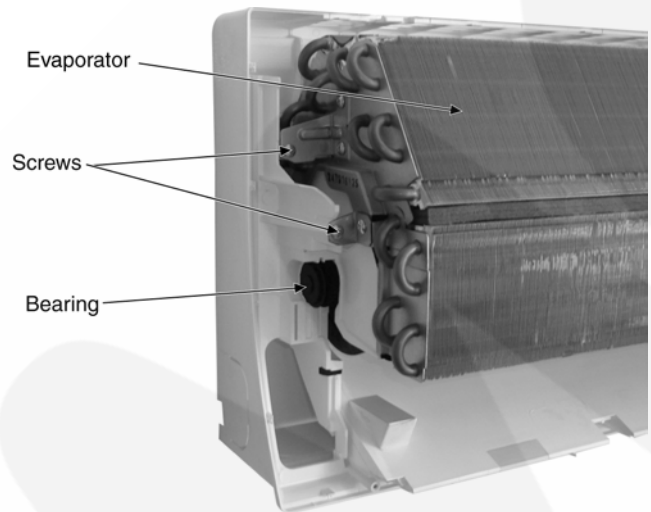

Fig. 8

- Push up the Evaporator and pull out the Cross Flow Fan from shaft. By then, Fan Motor can be taken out. (Fig. 9)

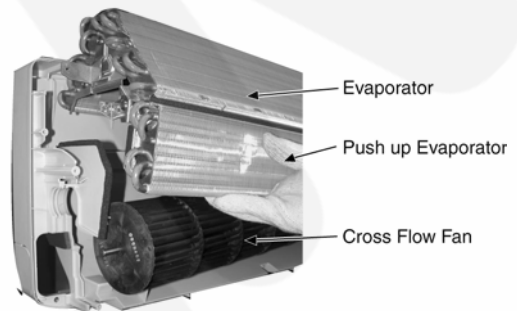
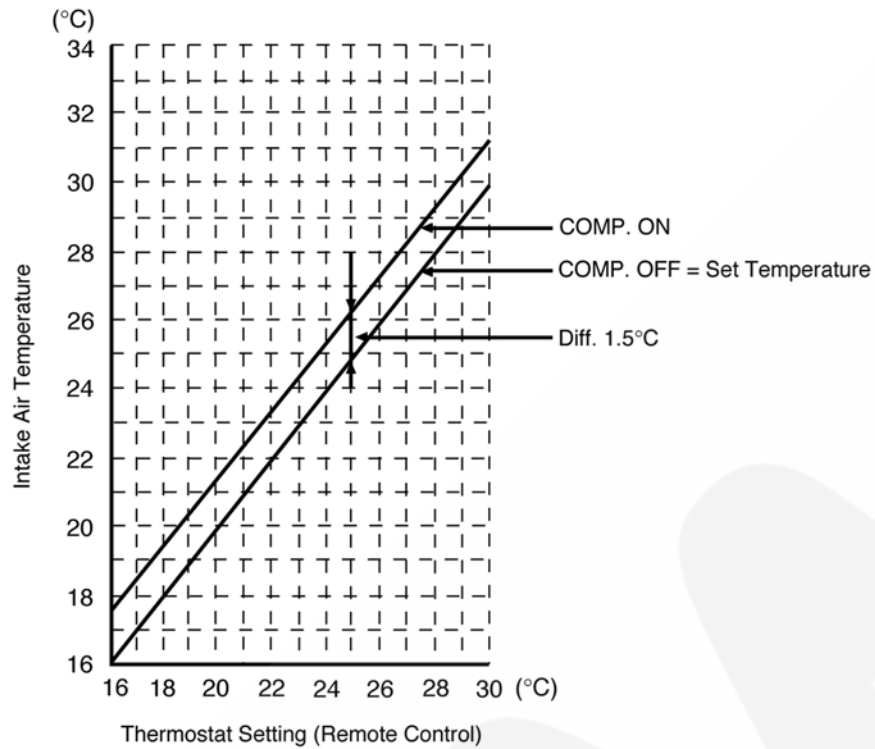

Fig. 9

15 Technical Data

15.1. Thermostat Characteristics

- Cooling



- Soft Dry

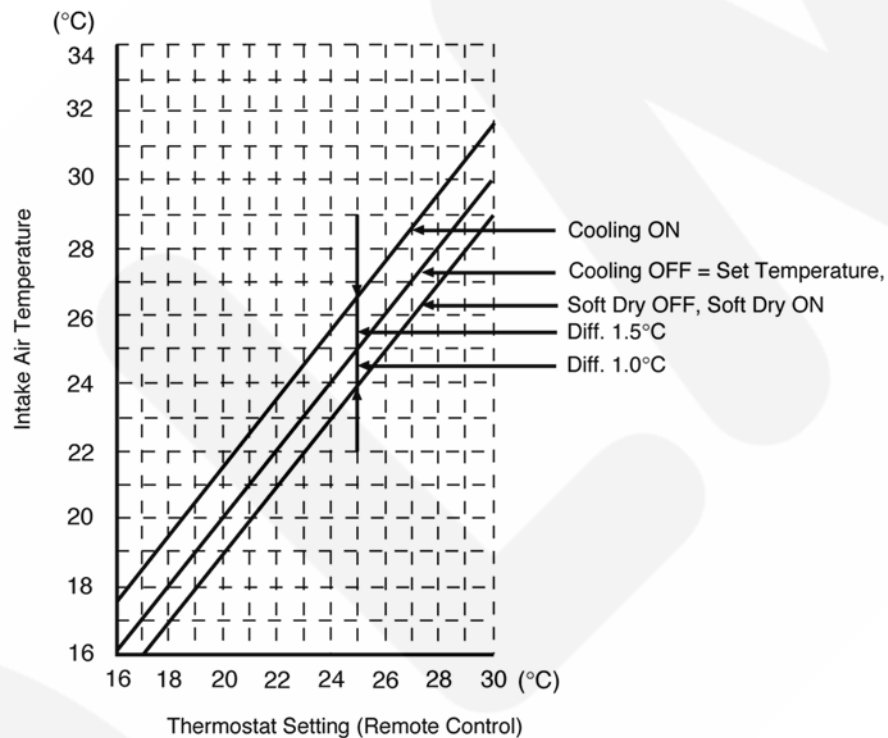

15.2. Sensible Capacity Chart

230V Indoor wet bulb temp.	Outdoor Temp. (°C)											
	30			35			40			46		
	TC	SHC	IP	TC	SHC	IP	TC	SHC	IP	TC	SHC	IP
17.0°C	7.85	5.95	2.25	7.33	5.70	2.42	6.82	5.48	2.59	6.20	5.21	2.80
19.0°C				7.91		2.46						
19.5°C	8.61	6.23	2.30	8.05	5.98	2.47	7.49	5.76	2.64	6.81	5.48	2.85
22.0°C	9.39	6.46	2.34	8.77	6.21	2.51	8.16	5.99	2.69	7.42	5.71	2.90

TC - Total Cooling Capacity (kW)
 SHC - Sensible Heat Capacity (kW)
 IP - Input Power (kW)

Indoor 27°C/19°C
 Outdoor 35°C/24°C

15.3. Operation Characteristics

15.3.1. CS-V28EKE CU-V28EKE

• Cooling Characteristic

[Condition] Room temperature: 27/19°C
Cooling operation: At High fan
Piping length: 5 m

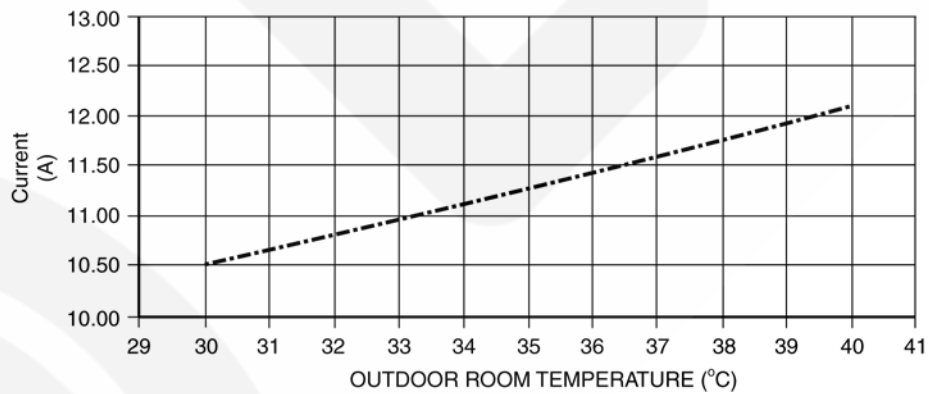
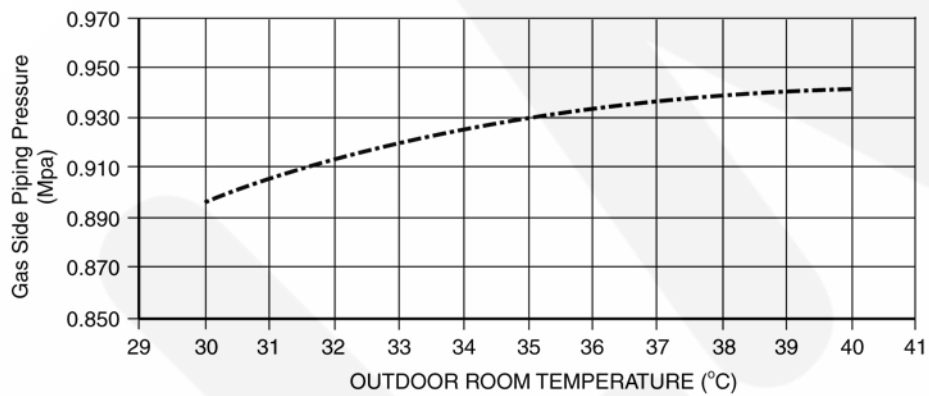
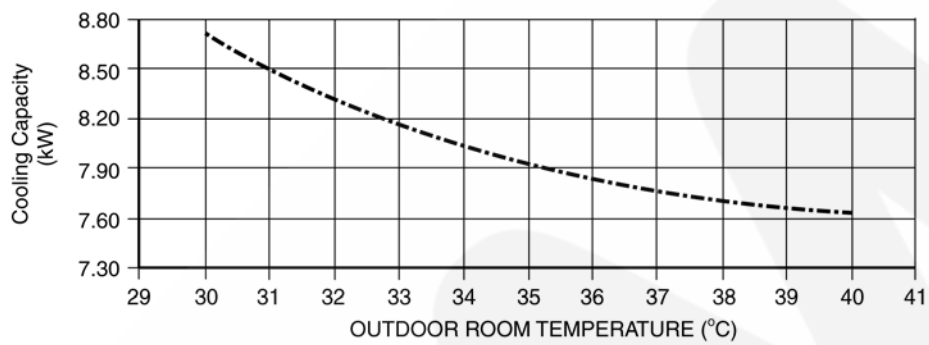
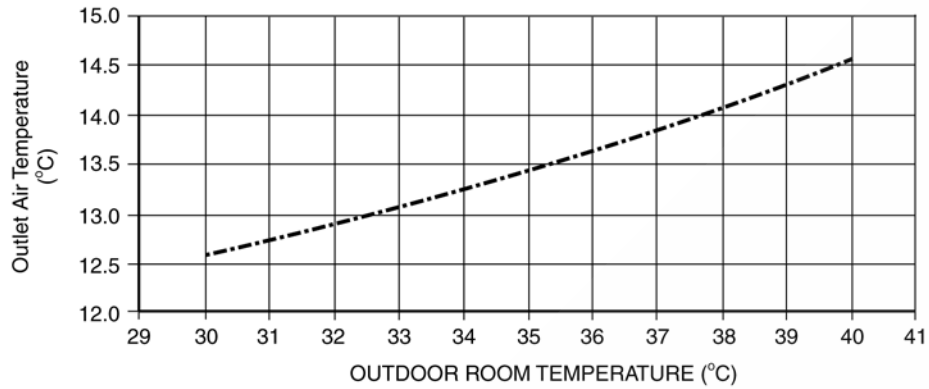

• Piping Length Characteristic (Cooling)

[Condition] Room temperature: 27/19°C
 Outdoor temperature: 35/24°C
 Cooling operation: At High fan

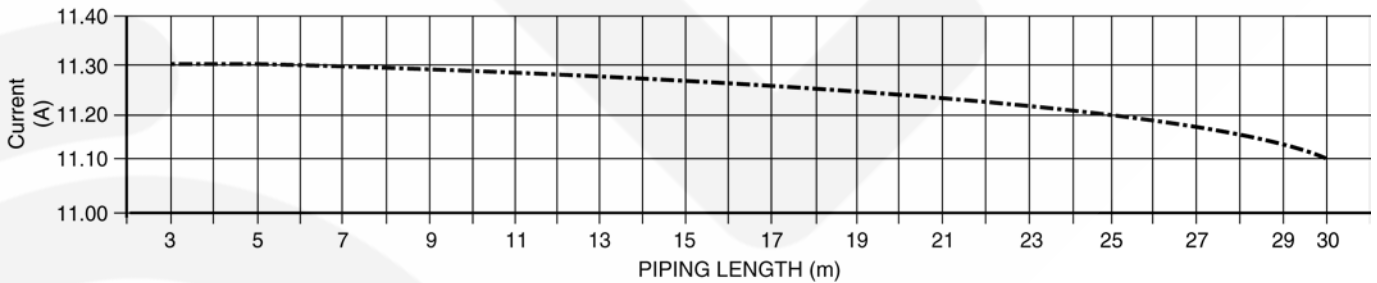
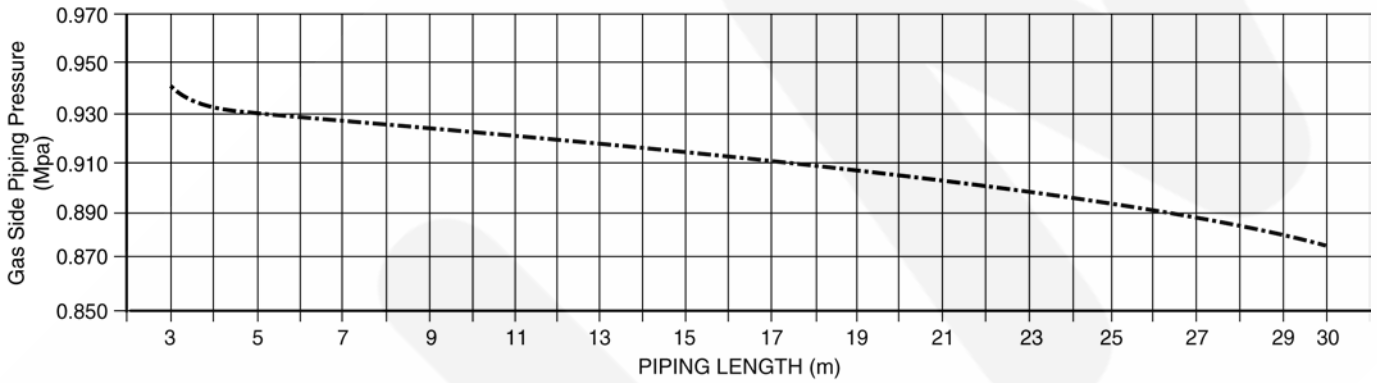
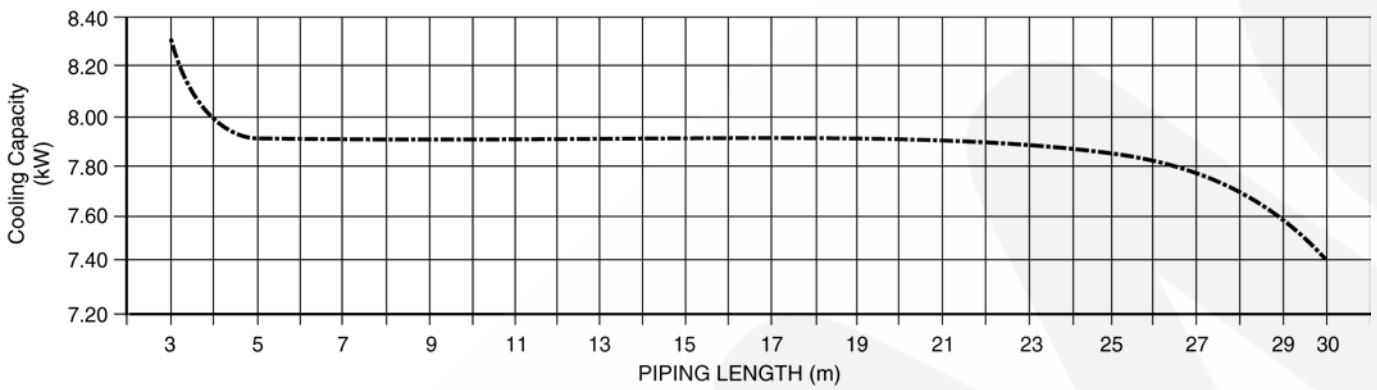
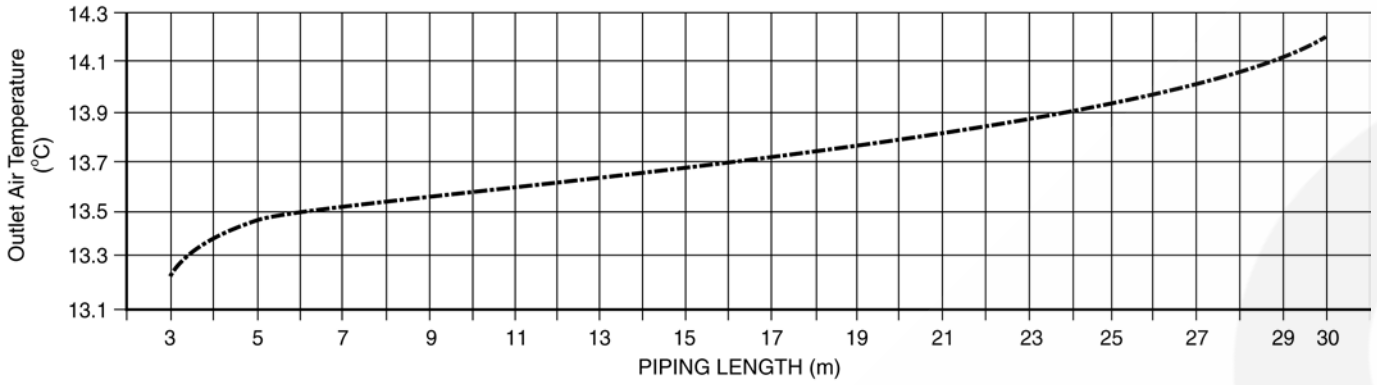

16 Exploded View and Replacement Parts List

16.1. CS-V28EKE

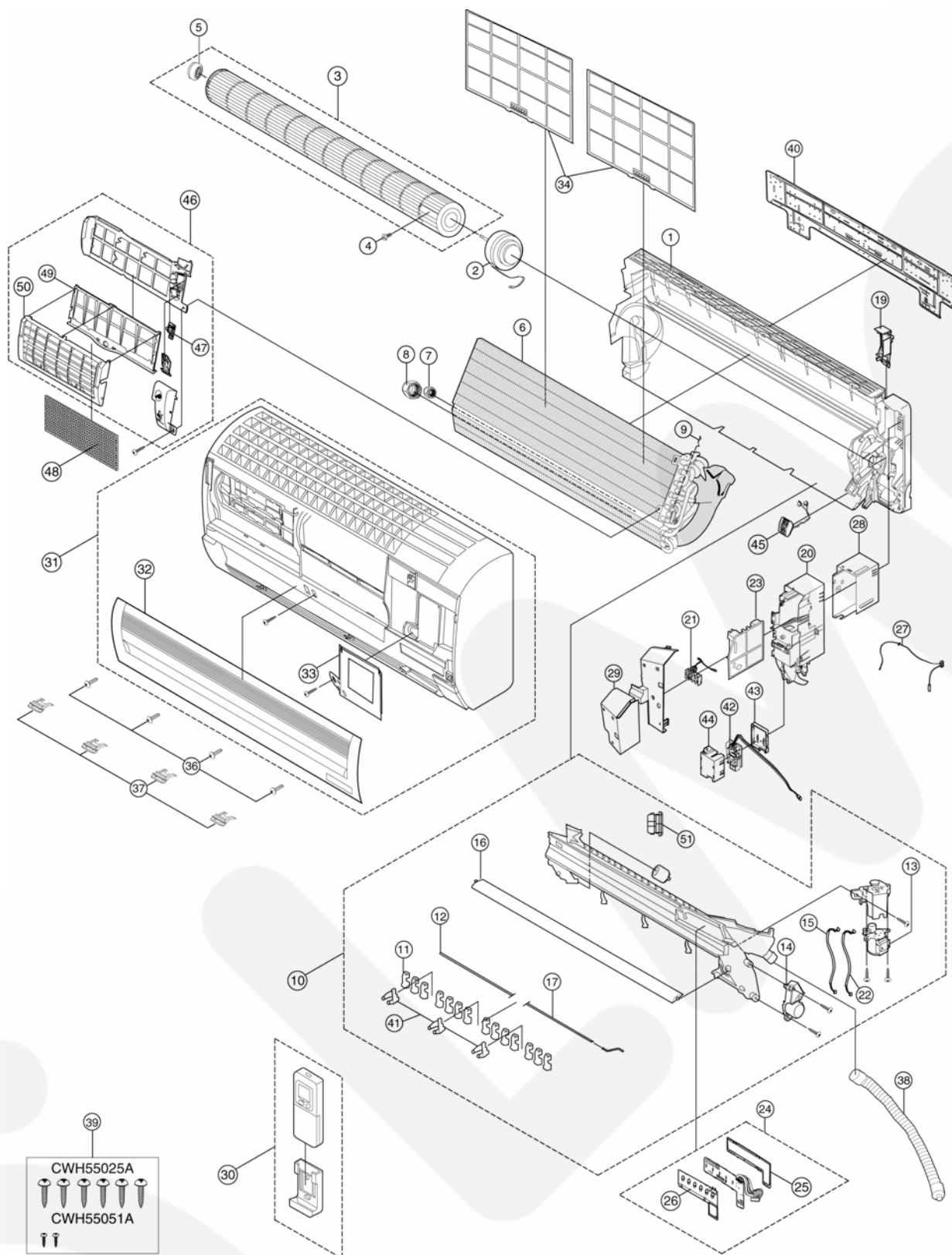

Note:
The above exploded view is for the purpose of parts disassembly and replacement.
The non-numbered parts are not kept as standard service parts.

<Model: CS-V28EKE>

REF NO.	DESCRIPTION & NAME	QTY.	CS-V28EKE	REMARKS
1	CHASSY COMPLETE	1	CWD50C1498	
2	FAN MOTOR	1	ARW42A8P60AC	O
3	CROSS FLOW FAN COMPLETE	1	CWH02C1044	
4	SCREW - CROSS FLOW FAN	1	CWH551146	
5	BEARING ASS'Y	1	CWH64K007	
6	EVAPORATOR	1	CWB30C1874	
7	FLARE NUT (1/4")	1	CWT251030	
8	FLARE NUT (5/8")	1	CWT251033	
9	HOLDER SENSOR	1	CWH32143	
10	DISCHARGE GRILLE COMPLETE	1	CWE20C2527	
11	VERTICAL VANE	14	CWE241196	
12	CONNECTING BAR	1	CWE261094	
13	AIR SWING MOTOR	1	CWA981162J	O
14	AIR SWING MOTOR	1	CWA981106J	O
15	LEAD WIRE - AIR SWING MOTOR	1	CWA67C6023	
16	HORIZONTAL VANE	1	CWE241197	
17	CONNECTING BAR	1	CWE261095	
19	BACK COVER CHASSIS	1	CWD932631	
20	CONTROL BOARD CASING	1	CWH102299	
21	TERMINAL BOARD COMPLETE	1	CWA28C2082J	O
22	LEAD WIRE - AIR SWING MOTOR	1	CWA67C6219	
23	ELECTRONIC CONTROLLER - MAIN	1	CWA744290	O
24	INDICATOR & RECEIVER COMPLETE	1	CWE39C1156	O
25	INDICATOR HOLDER	1	CWD932633	
26	INDICATOR HOLDER	1	CWD932634	
27	SENSOR COMPLETE	1	CWA50C2366	O
28	CONTROL BOARD TOP COVER	1	CWH131265	
29	CONTROL BOARD FRONT COVER	1	CWH131266	
30	REMOTE CONTROL COMPLETE	1	CWA75C2620	O
31	FRONT GRILLE COMPLETE	1	CWE11C3468	O
32	INTAKE GRILLE COMPLETE	1	CWE22C1274	
33	GRILLE DOOR	1	CWE141092	
34	AIR FILTER	2	CWD001193	
36	SCREW - FRONT GRILLE	4	XTT4+16CFJ	
37	CAP - FRONT GRILLE	4	CWH521142	
38	DRAIN HOSE	1	CWH85284	
39	BAG COMPLETE - INSTALLATION SCREW	1	CWH82C1423	
40	INSTALLATION PLATE	1	CWH361079	
41	FULCRUM	3	CWH621063	
42	ELECTRONIC CONTROLLER - IONIZER	1	CWA744382	O
43	CASING - IONIZER	1	CWD932464	
44	CASING - IONIZER	1	CWD932527	
45	ION - GENERATOR	1	CWH94C0012	
46	SUPERSONIC AIR PURIFYING DEVICE	1	CWH91C1017	
47	ELEC. CONTROLLER - SUPERSONIC	1	CWA743874	O
48	SUPER ALLERU BUSTER FILTER	1	CWD00C1133	O
49	FRAME FR AIR FILTER SUPERSONIC	1	CWD011027	
50	FRAME FR AIR FILTER SUPERSONIC	1	CWD011026	
51	CAP - DRAIN TRAY	1	CWH52160C	

(Note)

- All parts are supplied from PHAAM, Malaysia (Vendor Code: 061).
- "O" marked parts are recommended to be kept in stock.

16.2. CU-V28EKE

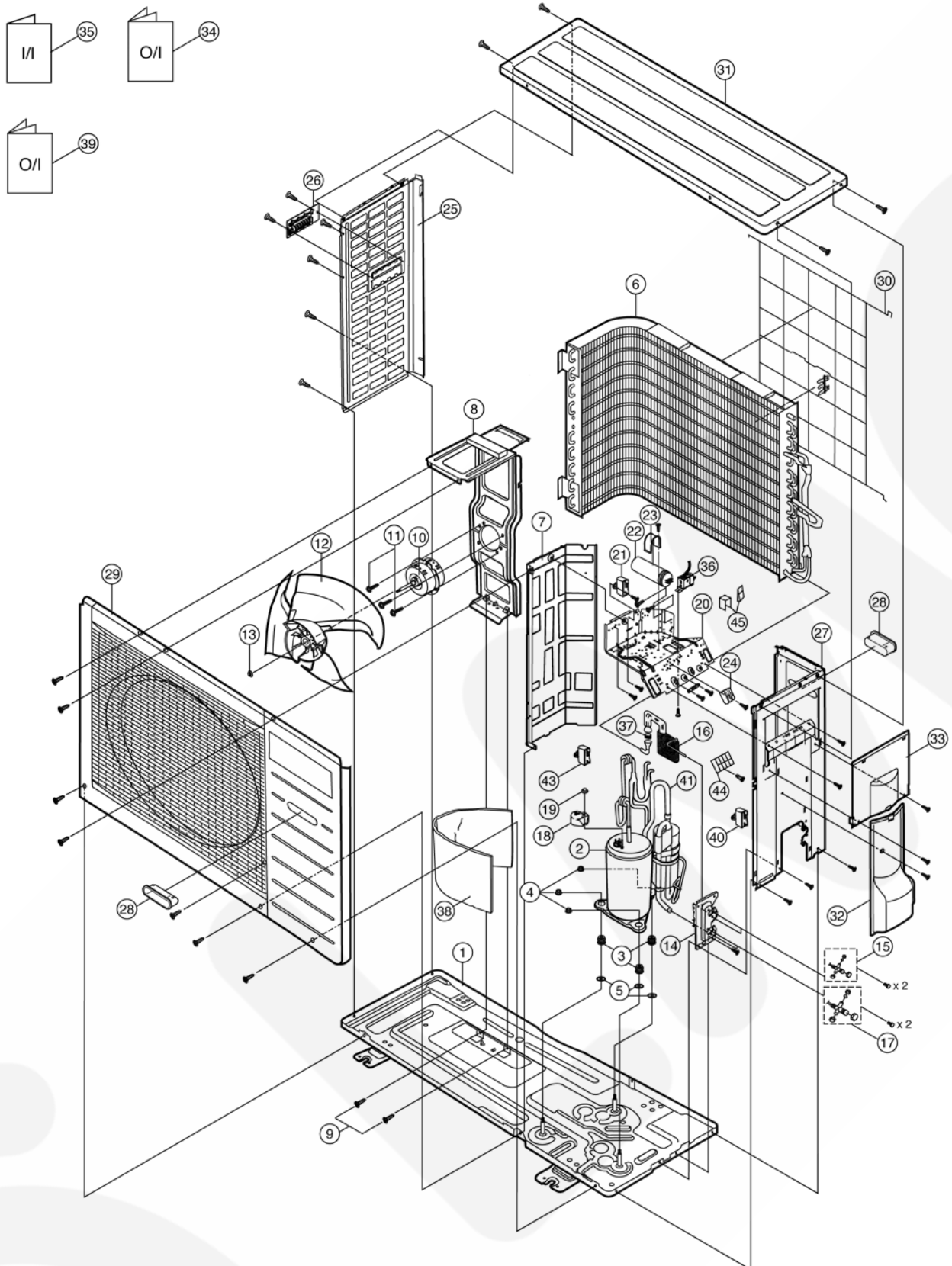

Note:

The above exploded view is for the purpose of parts disassembly and replacement.
The non-numbered parts are not kept as standard service parts.

<Model: CU-V28EKE>

REF. NO.	PART NAME & DESCRIPTION	QTY.	CU-V28EKE	REMARKS
1	CHASSY ASS'Y	1	CWD50K2100	
2	COMPRESSOR	1	5JS290DAD21	O
3	ANTI - VIBRATION BUSHING	3	CWH50055	
4	NUT - COMPRESSOR MOUNT	3	CWH561049	
5	PACKING	3	CWB81043	
6	CONDENSER	1	CWB32C1787	
7	SOUND PROOF BOARD ASS'Y	1	CWH151051	
8	FAN MOTOR BRACKET	1	CWD541065	
9	SCREW - FAN MOTOR BRACKET	2	CWH551060J	
10	FAN MOTOR	1	CWA951354J	O
11	SCREW - FAN MOTOR MOUNT	3	CWH55252J	
12	PROPELLER FAN ASS'Y	1	CWH03K1017	
13	NUT - PROPELLER FAN	1	CWH561038J	
14	HOLDER COUPLING ASS'Y	1	CWH351036	
15	2-WAY VALVE (LIQUID)	1	CWB021294	O
16	TUBE ASS'Y (CAPILLARY TUBE & STRAINER)	1	CWT024161	
17	3-WAY VALVE (GAS)	1	CWB011363	O
18	TERMINAL COVER	1	CWH171012	
19	NUT - TERMINAL COVER	1	CWH7080300J	
20	CONTROL BOARD CASING	1	CWH102206	
21	CAPACITOR - FAN MOTOR	1	DS441505NPQB	O
22	CAPACITOR - COMPRESSOR	1	DS441606CPNA	O
23	HOLDER CAPACITOR	1	CWH30071	
24	TERMINAL BOARD ASS'Y	1	CWA28K1091J	
25	CABINET SIDE PLATE (L)	1	CWE041082A	
26	HANDLE	1	CWE161010	
27	CABINET SIDE PLATE (R)	1	CWE041100A	
28	HANDLE	2	CWE16000E	
29	CABINET FRONT PLATE	1	CWE06K1043	
30	WIRE NET	1	CWD041041A	
31	CABINET TOP PLATE ASS'Y	1	CWE03K1009A	
32	CONTROL BOARD COVER	1	CWH131168	
33	CONTROL BOARD COVER	1	CWH131169A	
34	OPERATION INSTRUCTIONS	1	CWF565163	
35	INSTALLATION INSTRUCTIONS	1	CWF612943	
36	THERMOSTAT	1	CWA151040	
37	STRAINER	1	CWB11004	
38	SOUND PROOF MATERIAL	1	CWG302397	
39	OPERATION INSTRUCTIONS	1	CWF565226	
40	TERMINAL BOARD ASS'Y	1	CWA28K1144	
41	CHECK VALVE COMPLETE	1	CWB03C1062	
43	TERMINAL BOARD	1	CWA28K1091J	
44	TERMINAL BOARD	1	CWA28K224J	
45	MAGNETIC RELAY	1	K6C1A9A00001	

(Note)

- All parts are supplied from PHAAM, Malaysia (Vendor Code: 061).
- "O" marked parts are recommended to be kept in stock.