

Service Manual

Air Conditioner

CS-V18DKE CU-V18DKE
CS-V24DKE CU-V24DKE

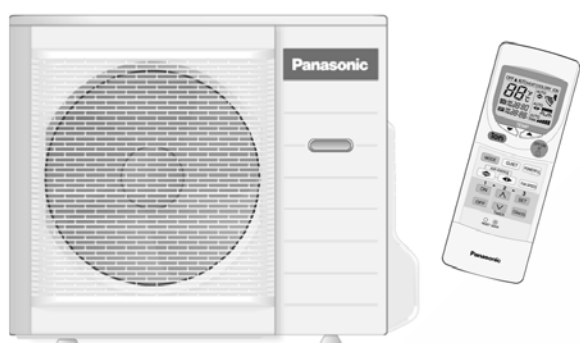

⚠ WARNING

This service information is designed for experienced repair technicians only and is not designed for use by the general public. It does not contain warnings or cautions to advise non-technical individuals of potential dangers in attempting to service a product. Products powered by electricity should be serviced or repaired only by experienced professional technicians. Any attempt to service or repair the product or products dealt with in this service information by anyone else could result in serious injury or death.

⚠ PRECAUTION OF LOW TEMPERATURE

In order to avoid frostbite, be assured of no refrigerant leakage during the installation or repairing of refrigeration circuit.

CONTENTS

	Page		Page
1 Features	2	8 Operation Details	16
2 Functions	3	8.1. Cooling Operation	16
2.1. Remote Control	3	8.2. Soft Dry Operation	17
2.2. Indoor Unit	4	8.3. Automatic Operation	18
2.3. Outdoor Unit	5	8.4. Operation Control	18
3 Product Specifications	6	8.5. Indoor Fan Speed Control	20
3.1. CS-V18DKE CU-V18DKE	6	8.6. Outdoor Fan Speed Control	22
3.2. CS-V24DKE CU-V24DKE	8	8.7. Vertical Airflow Direction Control	22
4 Dimensions	10	8.8. Horizontal Airflow Direction Control	23
4.1. Indoor Unit & Remote Control	10	8.9. Powerful Operation	24
4.2. Outdoor Unit	11	8.10. Quiet Operation	24
5 Refrigeration Cycle Diagram	12	8.11. Ionizer Operation	25
6 Block Diagram	13	8.12. Timer Control	26
7 Wiring Diagram	14	8.13. Random Auto Restart Control	27

Panasonic®

© 2004 Panasonic HA Air-Conditioning (M) Sdn Bhd (11969-T). All rights reserved. Unauthorized copying and distribution is a violation of law.

8.14. Remote Control Signal Receiving Sound	27	13.3. Diagnosis Methods Of A Malfunction Of A Compressor And 4-way Valve	60
9 Operating Instructions	28	14 Technical Data	61
10 Installation Instructions	34	14.1. Thermostat Characteristics	61
10.1. Safety Precautions	34	14.2. Sensible Capacity Chart	61
10.2. Indoor Unit	37	14.3. Operation Characteristics	62
10.3. Outdoor Unit	41	15 Exploded View (Indoor Unit)	63
11 Installation And Servicing Air Conditioner Using R410A	44	15.1. CS-V18DKE CS-V24DKE	63
11.1. Outline	44	16 Replacement Parts List (Indoor Unit)	64
11.2. Tools For Installing/Servicing Refrigerant Piping	45	16.1. CS-V18DKE CS-V24DKE	64
11.3. Refrigerant Piping Work	49	17 Exploded View (Outdoor Unit)	65
11.4. Installation, Transferring, Servicing	51	17.1. CU-V18DKE CU-V24DKE	65
12 Servicing Information	55	18 Replacement Parts List (Outdoor Unit)	66
12.1. Distinction Of Lead Free (PbF) Printed Circuit Board	55	18.1. CU-V18DKE CU-V24DKE	66
12.2. Indoor Electronic Controllers Removal Procedures	55	19 Electronic Circuit Diagram	67
12.3. Cross Flow Fan and Indoor Fan Motor Removal Procedures	56	19.1. Indoor Unit & Outdoor Unit	67
12.4. Remote Control Reset	58	19.2. Remote Control	73
12.5. Auto OFF/ON Button	58	19.3. Print Pattern Indoor Unit Printed Circuit Board	74
13 Troubleshooting Guide	59	19.4. Print Pattern Indicator & Receiver Printed Circuit Board	76
13.1. Refrigeration Cycle System	59		
13.2. Relationship Between The Condition Of The Air Conditioner And Pressure And Electric Current	60		

1 Features

- High efficiency.
- Compact design.
- Wider range of horizontal discharge air.
- Air Filter with function to reduce dust and smoke.
- Automatic air swing and manual adjusted by Remote Control for horizontal and vertical airflow.
- Long installation piping up to 25 meter.
- Supersonic Air Purifying System with Super Alleru-Buster.
 - Inactive various harmful airborne elements including allergens, viruses and bacteria.
 - Generated supersonic waves enhance the ability to collect dust and dirt in the air.
- **Quality Improvement**
 - Random auto restart after power failure for safety restart operation.
 - Gas leakage detection.
 - Prevent Compressor reverse cycle.
 - Inner protector to protect Compressor.
 - Noise prevention during soft dry operation.
 - Blue coated Condenser for high resistance to corrosion.
 - Anti-dew formation control (Cooling & Soft Dry).

- **Operation Improvement**
 - Quiet mode to provide quiet operation.
 - Powerful mode to reach the desired room temperature quickly.
 - Ionizer control for generating negative ion in discharge air.
 - 24-hour timer setting.
- **Serviceability Improvement**
 - Removable and washable Front Panel.
- **Environmental Friendly**
 - R410A, which does not contain chlorine, is used as its refrigerant, so there is no danger of damage to the ozone layer in stratosphere.

2 Functions

2.1. Remote Control

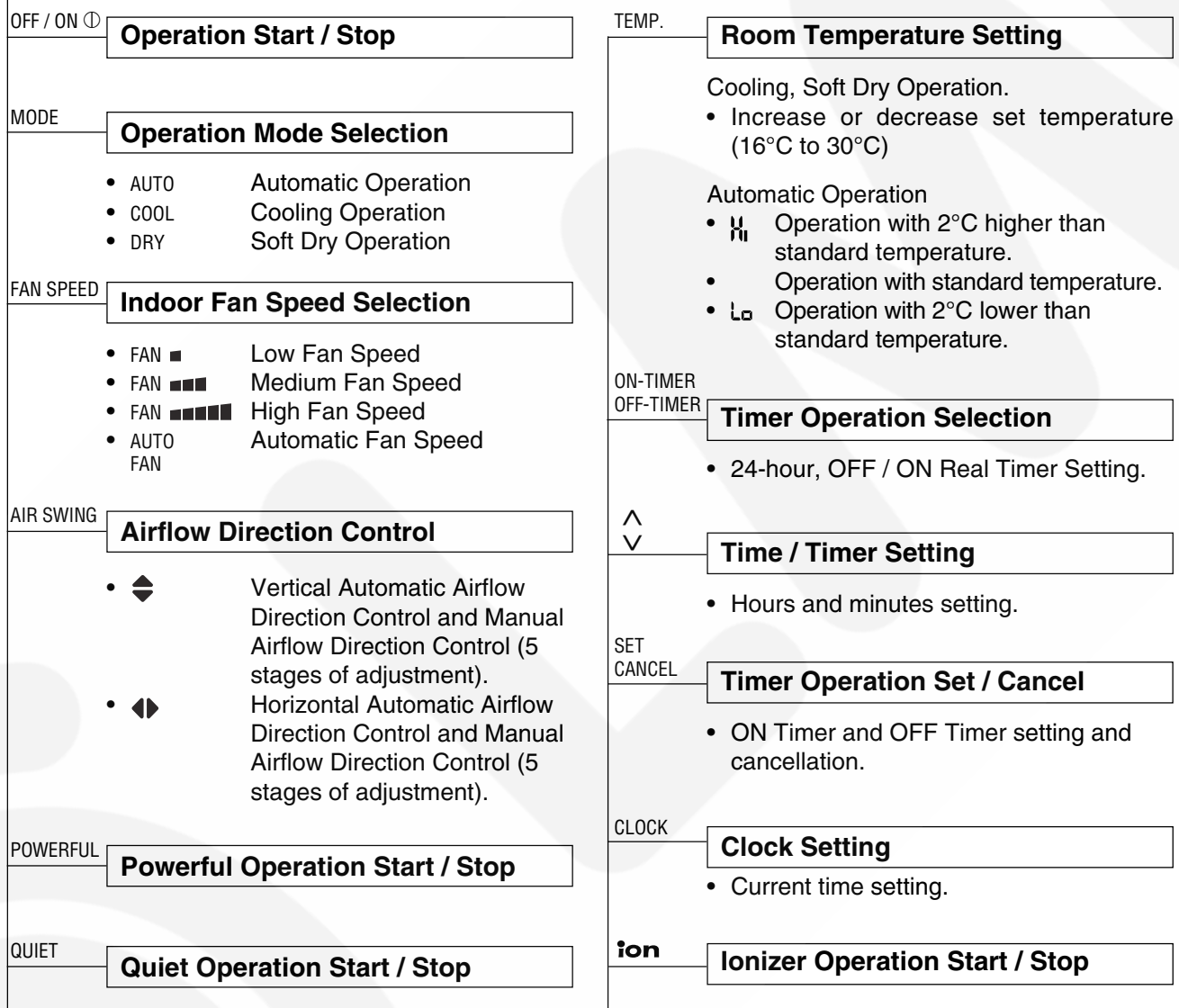
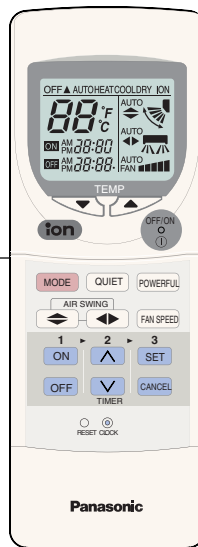

2.2. Indoor Unit



AUTO
OFF / ON

Automatic Operation Button

- Press for < 5 second to operate Automatic operation mode. Used when the remote control cannot be used.
- Press for ≥ 5 second to operate Cooling operation mode and compressor force to on ("beep" sound will heard). Used when test running or servicing.
- Within 20 second of Cooling operation, press continuously for ≥ 5 second to enter various setting mode. "beep, beep" sound will be heard. (Used to toggle remote control signal receiving sound or select remote control transmission code).

Operation Indication Lamps (LED)

- POWER (Green) Lights up in operation, blinks in Automatic Operation judging.
- TIMER (Orange) Lights up in Timer Setting.
- QUIET (Orange) Lights up in Quiet Operation.
- POWERFUL (Orange) Lights up in Powerful Operation.
- ION (Green) Lights up in Ionizer Operation.
- SUPER ALLERU-BUSTER (Blue) ... Lights up in operation.

Operation Mode

- Cooling, Soft Dry and Automatic Operation.

Powerful Operation

- Reaches the desired room temperature quickly.

Timer Operation

- Delay OFF/ON Timer control.

Quiet Operation

- To provide quiet operation.

Ionizer Operation

- Generate and discharge negative ion.

Random Auto Restart Control

- Unit will be restarted, when resume from power failure, at previous setting.

Anti-Freezing Control

- To prevent indoor heat exchanger from freezing.

Indoor Fan Speed Control

- Manual control fan speed (High, Medium and Low).
- Automatic fan speed.

Airflow Direction Control

- Vertical airflow control can be adjusted automatically or manually by remote control.
- Horizontal airflow control can be adjusted automatically or manually by remote control.

Time Delay Safety Control

- Restarting is inhibited for approx. 3 minutes.

7 Minutes Time Save Control

- To reduce the built up humidity inside the room.

Anti-Dew Formation Control

- Anti-Dew Formation Control for indoor unit discharge area.

2.3. Outdoor Unit



Compressor Reverse Rotation Protection Control

- To protect compressor from reverse rotation when there is a instantaneous power failure.

Overload Protector

- Inner protector.

60 Secs. Forced Operation Control

- Once the compressor is activated, it does not stop within the first 60 secs. However, it stops immediately with remote control stop signal.

Outdoor Fan Operation Control

V24DK



- 4-pole induction motor (2 speed).
- For Cooling or Soft Dry operation
Hi-speed When outdoor temperature reaches to 31°C.
Lo-speed When outdoor temperature reaches to 29°C.

V18DK

- 4-pole induction motor (1 speed).

3 Product Specifications

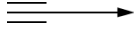
3.1. CS-V18DKE CU-V18DKE

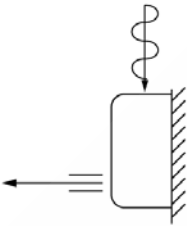
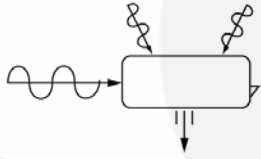

		Unit	CS-V18DKE	CU-V18DKE	
Power Source (Phase, Voltage, Cycle)		ϕ , V, Hz	Single, 230, 50		
Cooling Capacity		kW (BTU/h)	5.30 (18,100)		
Moisture Removal		l/h (Pint/h)	2.9 (6.1)		
Airflow Method		OUTLET  INTAKE 	SIDE VIEW 	TOP VIEW 	
Air Volume	Lo	m ³ /min (cfm)	12.5 (440)	—	
	Me	m ³ /min (cfm)	13.6 (480)	—	
	Hi	m ³ /min (cfm)	14.8 (520)	42.0 (1,480)	
	SHi	m ³ /min (cfm)	15.5 (550)	—	
Noise Level		dB (A)	High 42, Low 37	High 54	
		Power level dB	54	69	
Electrical Data	Input Power	kW	1.63		
	Running Current	A	7.3		
	EER	W/W (BTU/hW)	3.25 (11.10)		
	Starting Current	A	27.0		
Piping Connection Port (Flare piping)		inch inch	G ; Half Union 1/2" L ; Half Union 1/4"	G ; 3-way valve 1/2" L ; 2-way valve 1/4"	
Pipe Size (Flare piping)		inch inch	G ; (gas side) 1/2" L ; (liquid side) 1/4"	G ; (gas side) 1/2" L ; (liquid side) 1/4"	
Drain Hose	Inner diameter	mm	12	—	
	Length	mm	650	—	
Power Cord	Length	m	1.9	—	
	Number of core-wire		3 (1.0 mm ²)	—	
Dimensions	Height	inch (mm)	10 - 13/16 (275)	29 - 17/32 (750)	
	Width	inch (mm)	39 - 9/32 (998)	34 - 7/16 (875)	
	Depth	inch (mm)	9 - 1/16 (230)	13 - 19/32 (345)	
Net Weight		lb (kg)	24 (11.0)	110 (50.0)	
Compressor	Description		—	Rotary (1 cylinder) rolling piston type	
	Motor Type		—	Induction (2-poles)	
	Rated Output	kW	—	1.5	
Air Circulation	Description		Cross-flow Fan	Propeller Fan	
	Material		ASHT-18	PP	
	Motor Type		Transistor (8-poles)	Induction (4-poles)	
	Input	W	44.8	119.6	
	Rated Output	W	30	50	
	Fan Speed	Low	rpm	1,150	—
		Medium	rpm	1,250	—
High		rpm	1,360	720	
SuperHigh		rpm	1,420	—	
Heat Exchanger	Description		Evaporator	Condenser	
	Tube material		Copper	Copper	
	Fin material		Aluminium (Pre Coat)	Aluminium	
	Fin Type		Slit Fin	Corrugated Fin	
	Row / Stage		(Plate fin configuration, forced draft)		
			2 × 15	2 × 34	
	FPI		21	16	
Size (W × H × L)		mm	810 × 315 × 25.4	850.5 × 714.0 × 25.4 870.5	

		Unit	CS-V18DKE	CU-V18DKE
Refrigerant Control Device			—	Capillary Tube
Refrigeration Oil		(cm ³)	—	FV50S (670)
Refrigerant (R410A)		g (oz)	—	1,340 (47.3)
Thermostat			Electronic Control	
Protection Device			—	Inner Protector
Capillary Tube	Length	mm	—	890
	Flow Rate	l/min	—	15.2
	Inner Diameter	mm	—	1.8
Air Filter	Material Style		P.P. Honeycomb	
				—
Capacity Control			Capillary Tube	
Compressor Capacitor		μF, VAC	—	50 μF, 400VAC
Fan Motor Capacitor		μF, VAC	—	3.5 μF, 450VAC

Note:

- Specifications are subject to change without notice for further improvement.

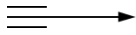
3.2. CS-V24DKE CU-V24DKE

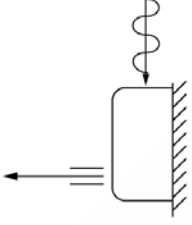
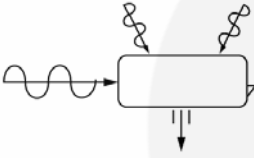
		Unit	CS-V24DKE	CU-V24DKE	
Power Source (Phase, Voltage, Cycle)		ø, V, Hz	Single, 230, 50		
Cooling Capacity		kW (BTU/h)	7.03 (24,000)		
Moisture Removal		l/h (Pint/h)	4.0 (8.5)		
Airflow Method		OUTLET  INTAKE 	SIDE VIEW 	TOP VIEW 	
Air Volume	Lo	m ³ /min (cfm)	13.8 (490)	26.7 (940)	
	Me	m ³ /min (cfm)	15.3 (540)	—	
	Hi	m ³ /min (cfm)	16.9 (600)	46.5 (1,640)	
	SHi	m ³ /min (cfm)	17.5 (620)	—	
Noise Level		dB (A)	High 46, Low 40	High 54	
		Power level dB	59	69	
Electrical Data	Input Power	kW	2.60		
	Running Current	A	12.3		
	EER	W/W (BTU/hW)	2.70 (9.23)		
	Starting Current	A	65.0		
Piping Connection Port (Flare piping)		inch inch	G ; Half Union 5/8" L ; Half Union 1/4"	G ; 3-way valve 5/8" L ; 2-way valve 1/4"	
Pipe Size (Flare piping)		inch inch	G ; (gas side) 5/8" L ; (liquid side) 1/4"	G ; (gas side) 5/8" L ; (liquid side) 1/4"	
Drain Hose	Inner diameter	mm	12	—	
	Length	mm	650	—	
Power Cord	Length	m	1.9	—	
	Number of core-wire		3 (2.5 mm ²)	—	
Dimensions	Height	inch (mm)	10 - 13/16 (275)	29 - 17/32 (750)	
	Width	inch (mm)	39 - 9/32 (998)	34 - 7/16 (875)	
	Depth	inch (mm)	9 - 1/16 (230)	13 - 19/32 (345)	
Net Weight		lb (kg)	24 (11.0)	130 (59.0)	
Compressor	Description		—	Rotary (1 cylinder) rolling piston type	
	Motor Type		—	Induction (2-poles)	
	Rated Output	kW	—	2.2	
Air Circulation	Description		Cross-flow Fan	Propeller Fan	
	Material		ASHT-18	PP	
	Motor Type		Transistor (8-poles)	Induction (4-poles)	
	Input	W	44.8	135	
	Rated Output	W	30	66	
	Fan Speed	Low	rpm	1,250	450
		Medium	rpm	1,390	—
		High	rpm	1,530	785
SuperHigh		rpm	1,590	—	
Heat Exchanger	Description		Evaporator	Condenser	
	Tube material		Copper	Copper	
	Fin material		Aluminium (Pre Coat)	Aluminium	
	Fin Type		Slit Fin	Corrugated Fin	
	Row / Stage		(Plate fin configuration, forced draft)		
			2 × 15	2 × 34	
	FPI		21	18	
Size (W × H × L)	mm	810 × 315 × 25.4	850.5 × 714.0 × 25.4 870.5		
Refrigerant Control Device			—	Capillary Tube	
Refrigeration Oil		(cm ³)	—	FV50S (1,130)	
Refrigerant (R410A)		g (oz)	—	1,470 (51.9)	

		Unit	CS-V24DKE	CU-V24DKE
Thermostat			Electronic Control	Mechanical Control
Protection Device			—	Inner Protector
Capillary Tube	Length	mm	—	645
	Flow Rate	l/min	—	23.5
	Inner Diameter	mm	—	2.0
Air Filter	Material Style		P.P. Honeycomb	—
Capacity Control			Capillary Tube	
Compressor Capacitor		μF , VAC	—	45 μF , 400VAC
Fan Motor Capacitor		μF , VAC	—	3.5 μF , 450VAC

Note:

- Specifications are subject to change without notice for further improvement.

4 Dimensions

4.1. Indoor Unit & Remote Control

4.1.1. CS-V18DKE CS-V24DKE

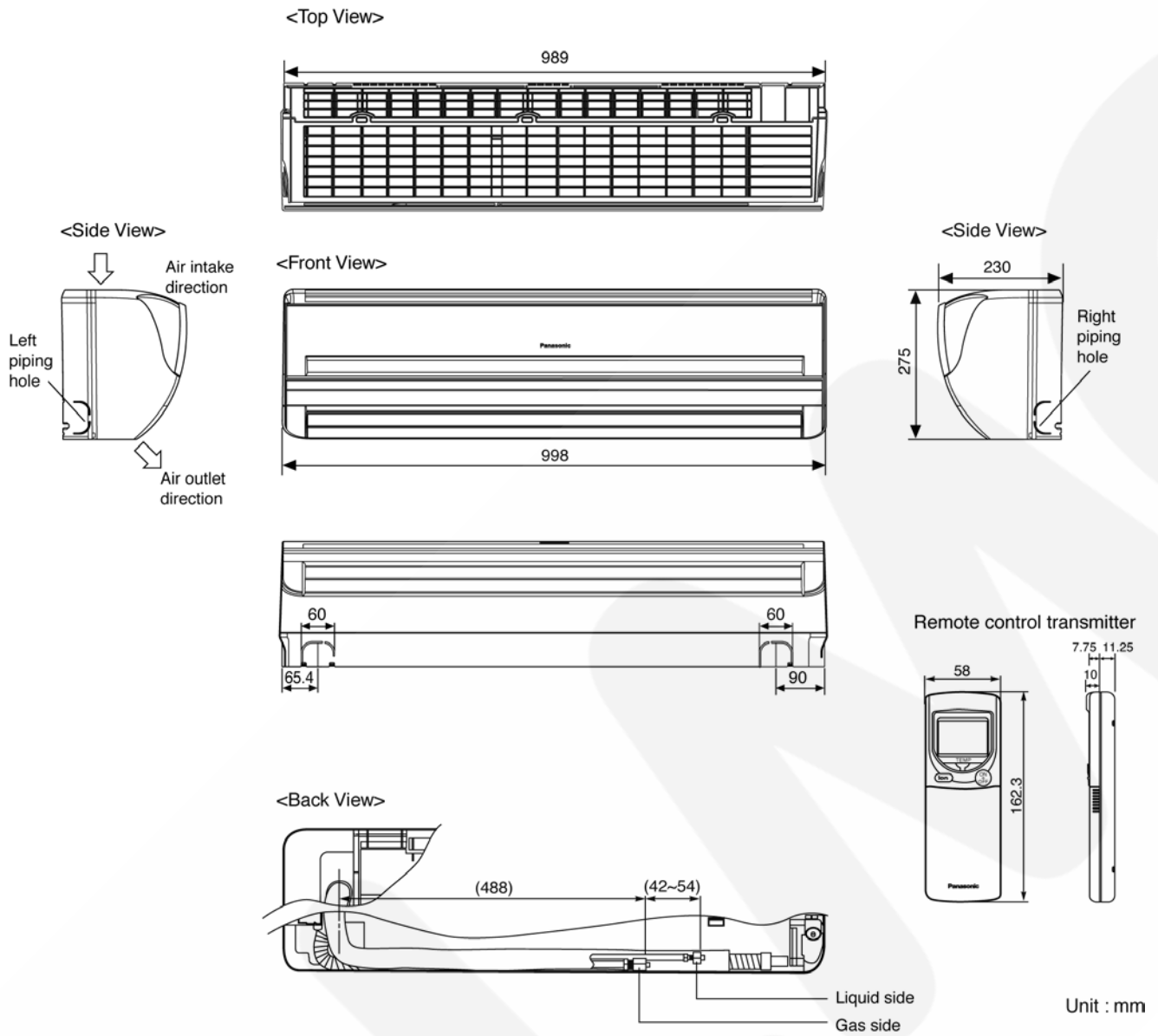

Relative position between the indoor unit and the installation plate <Front View>

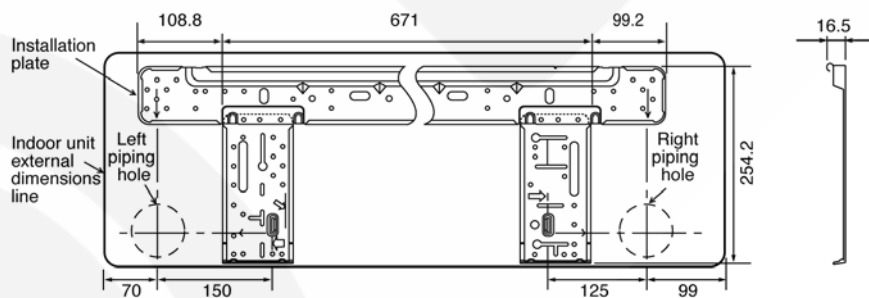

4.2. Outdoor Unit

4.2.1. CU-V18DKE CU-V24DKE

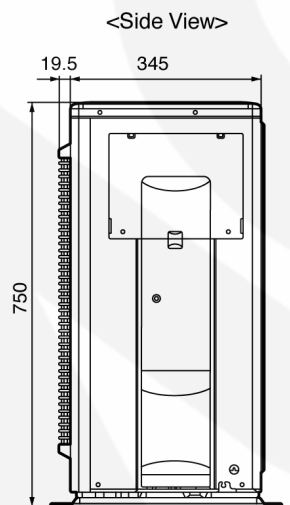
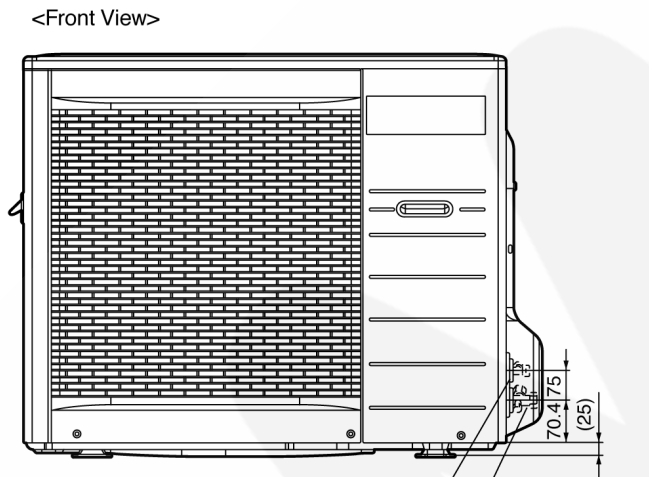
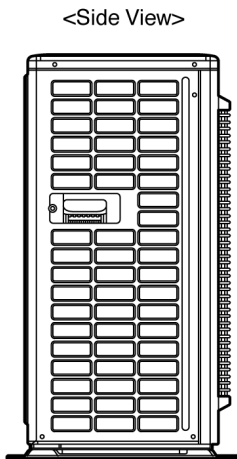
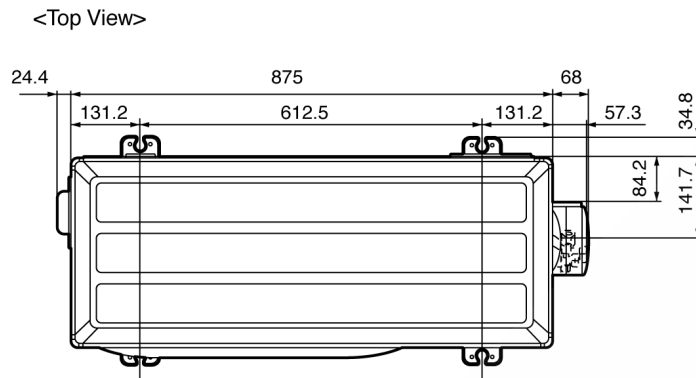
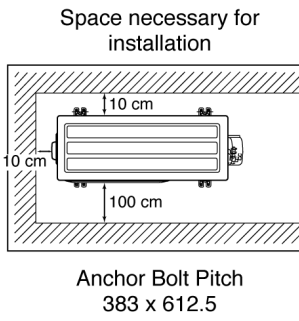

3-way valve at Gas side
(Low Pressure)

2-way valve at Liquid side
(High Pressure)

Unit: mm

5 Refrigeration Cycle Diagram

CS-V18DKE CU-V18DKE
 CS-V24DKE CU-V24DKE

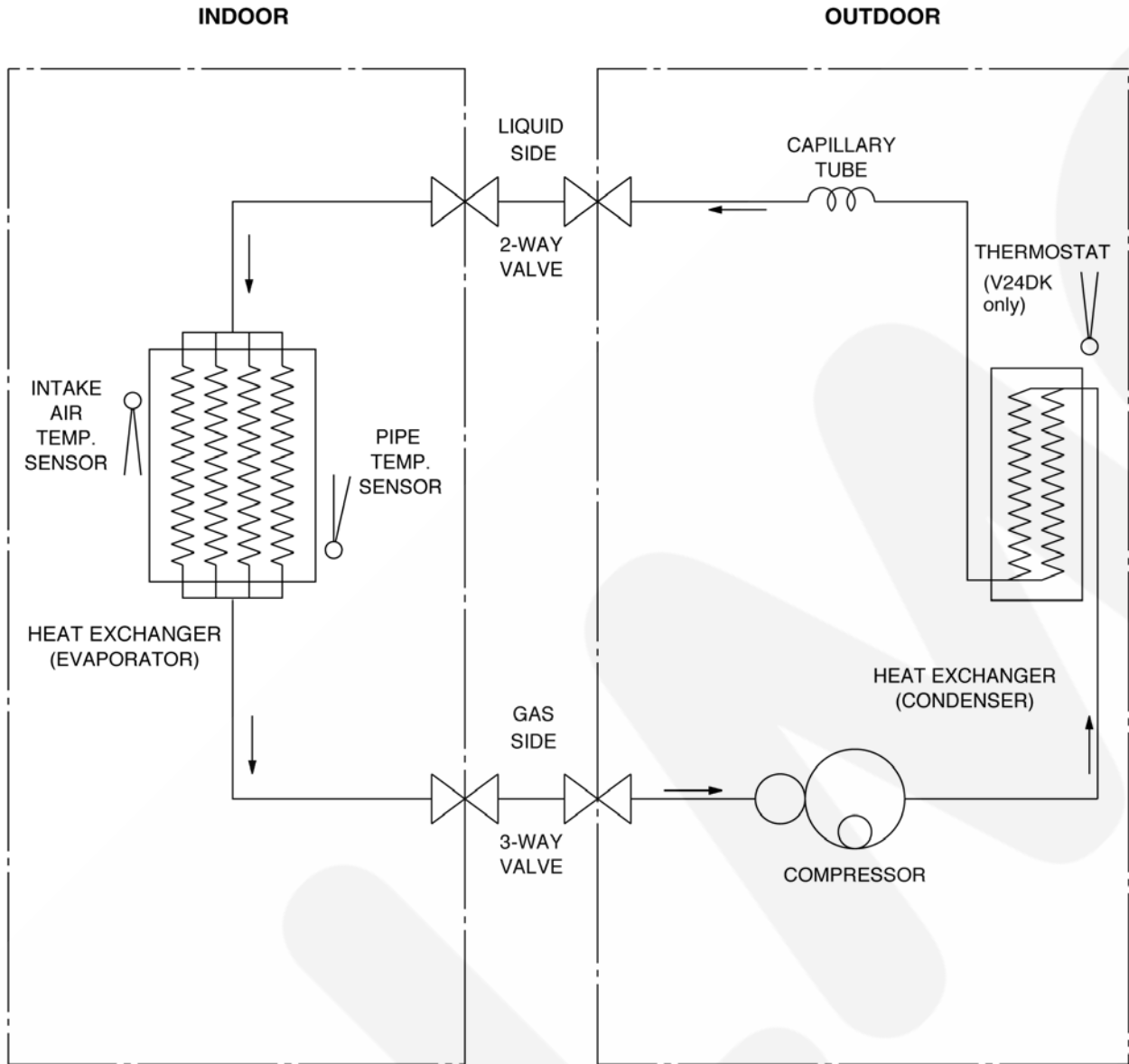

6 Block Diagram

CS-V18DKE CU-V18DKE
 CS-V24DKE CU-V24DKE

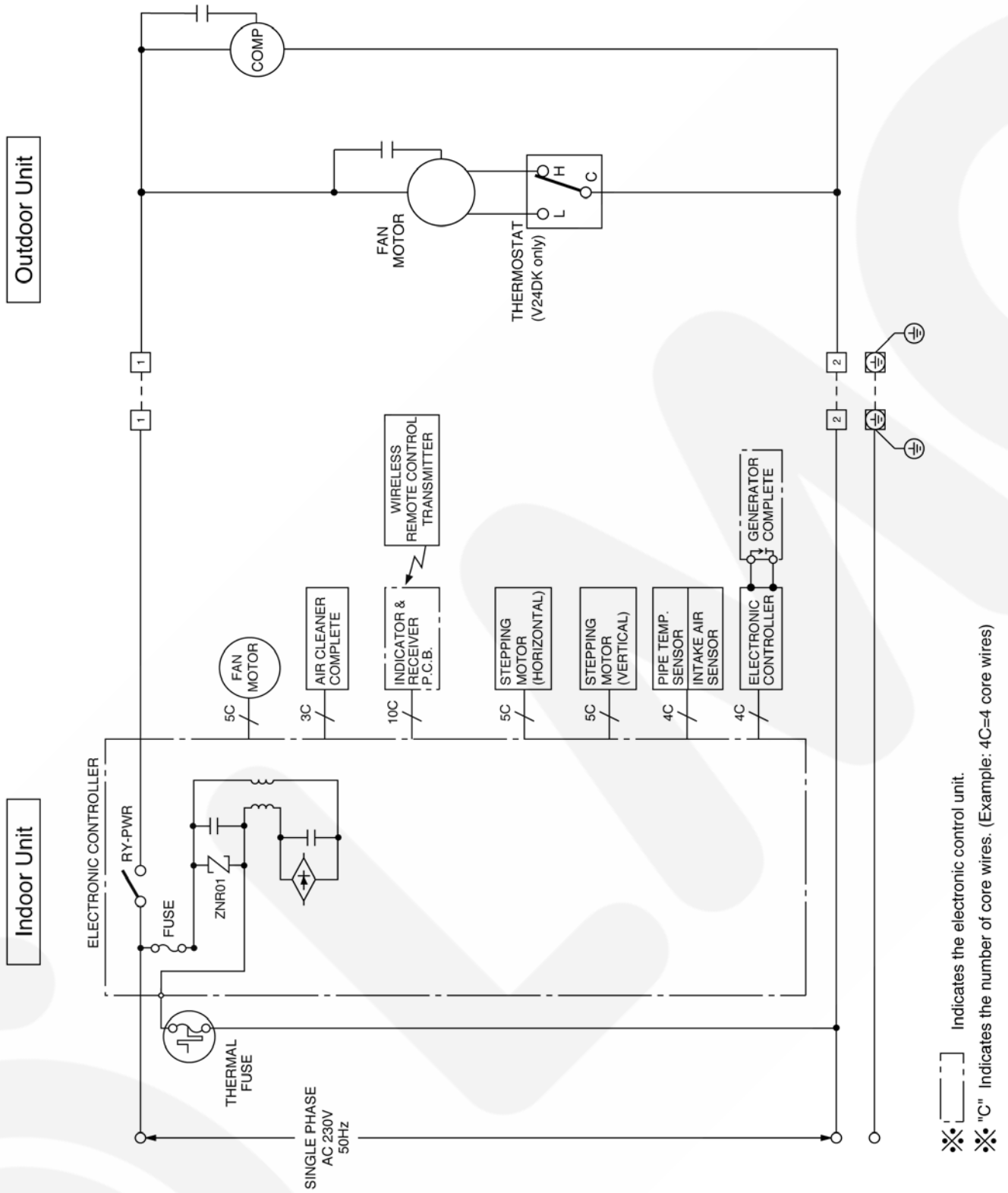

7 Wiring Diagram

CS-V18DKE CU-V18DKE

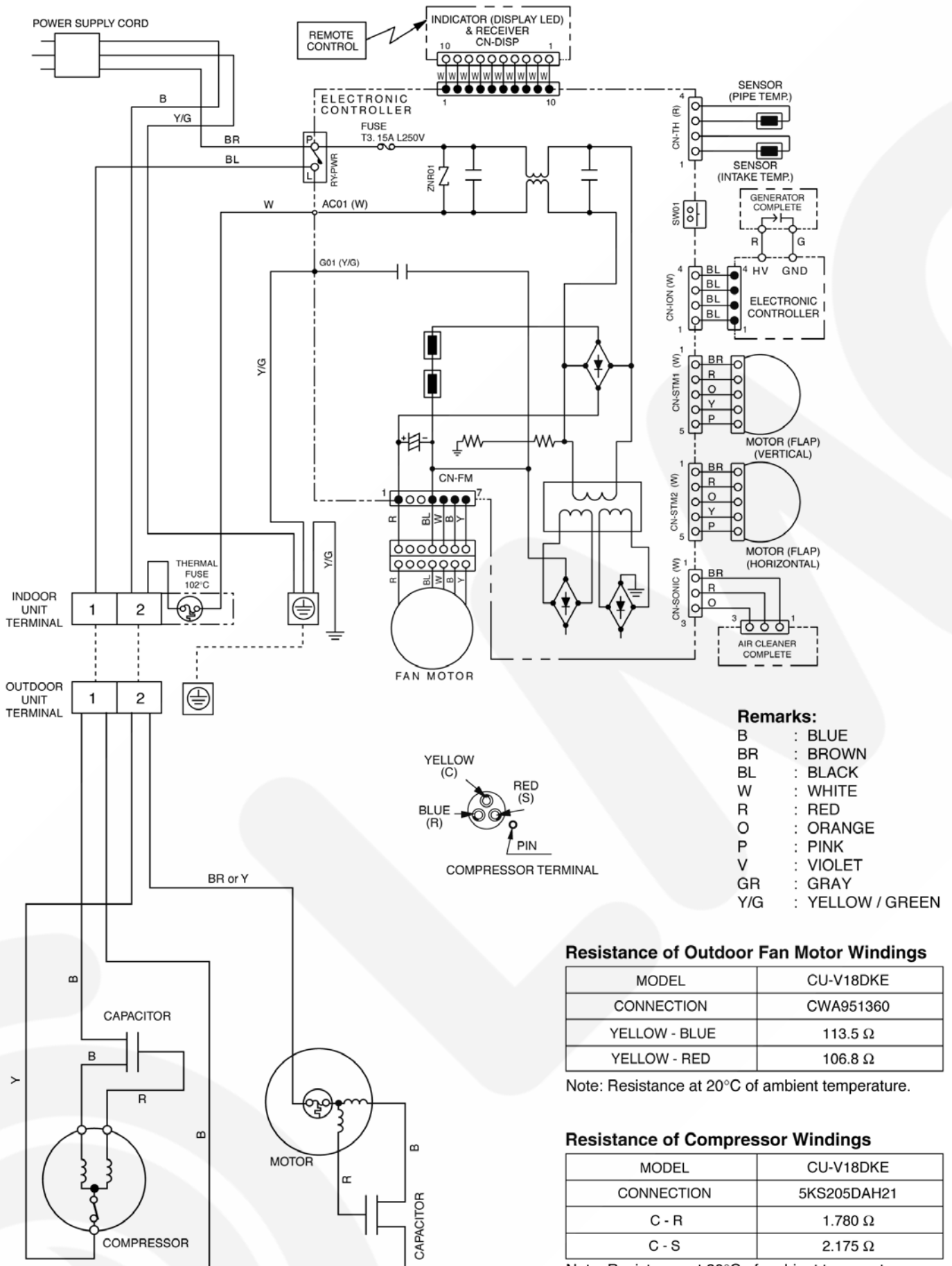

Remarks:

- B : BLUE
- BR : BROWN
- BL : BLACK
- W : WHITE
- R : RED
- O : ORANGE
- P : PINK
- V : VIOLET
- GR : GRAY
- Y/G : YELLOW / GREEN

Resistance of Outdoor Fan Motor Windings

MODEL	CU-V18DKE
CONNECTION	CWA951360
YELLOW - BLUE	113.5 Ω
YELLOW - RED	106.8 Ω

Note: Resistance at 20°C of ambient temperature.

Resistance of Compressor Windings

MODEL	CU-V18DKE
CONNECTION	5KS205DAH21
C - R	1.780 Ω
C - S	2.175 Ω

Note: Resistance at 20°C of ambient temperature.

CS-V24DKE CU-V24DKE

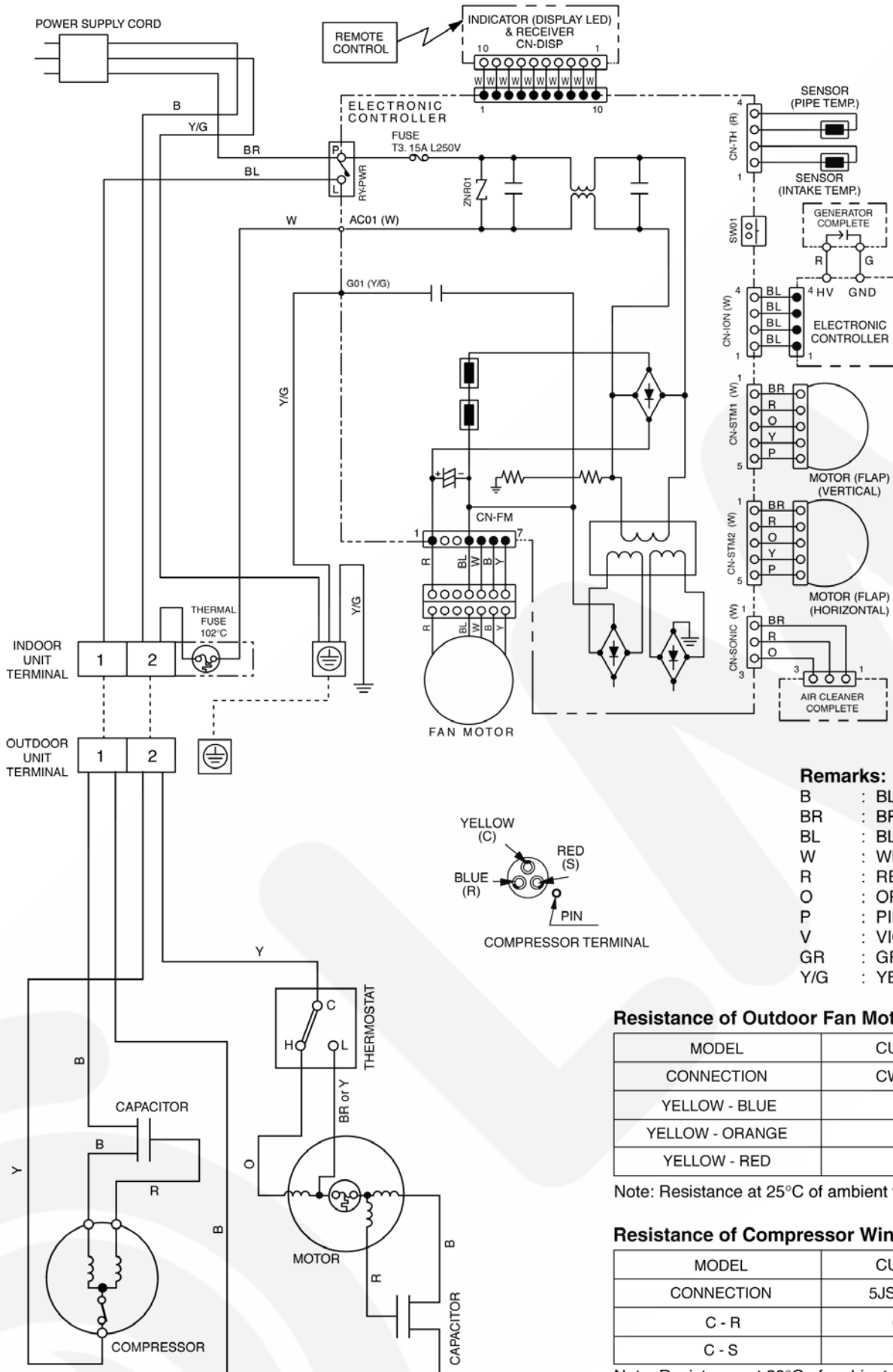

Remarks:

- B : BLUE
- BR : BROWN
- BL : BLACK
- W : WHITE
- R : RED
- O : ORANGE
- P : PINK
- V : VIOLET
- GR : GRAY
- Y/G : YELLOW / GREEN

Resistance of Outdoor Fan Motor Windings

MODEL	CU-V24DKE
CONNECTION	CWA951383
YELLOW - BLUE	116 Ω
YELLOW - ORANGE	136 Ω
YELLOW - RED	103 Ω

Note: Resistance at 25°C of ambient temperature.

Resistance of Compressor Windings

MODEL	CU-V24DKE
CONNECTION	5JS315DAA21
C - R	0.830 Ω
C - S	2.257 Ω

Note: Resistance at 20°C of ambient temperature.

8 Operation Details

8.1. Cooling Operation

- Cooling operation can be set using remote control.
- This operation is applied to cool down the room temperature reaches the setting temperature set on the remote control.
- The remote control setting temperature, which takes the reading of intake air temperature sensor, can be adjusted from 16°C to 30°C.
- During cooling operation, the compressor will stop running and restart as shown in below figure.

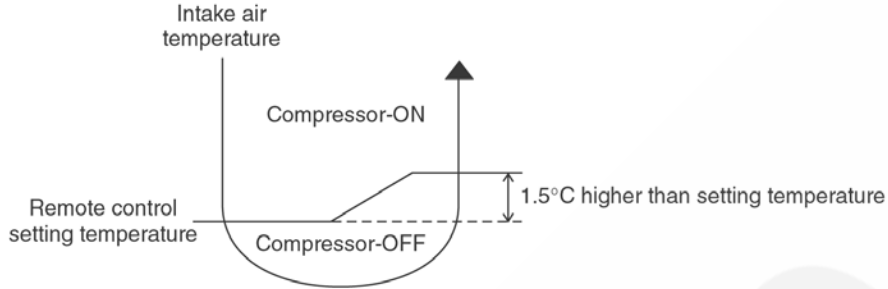

8.1.1. Cooling Operation Time Diagram

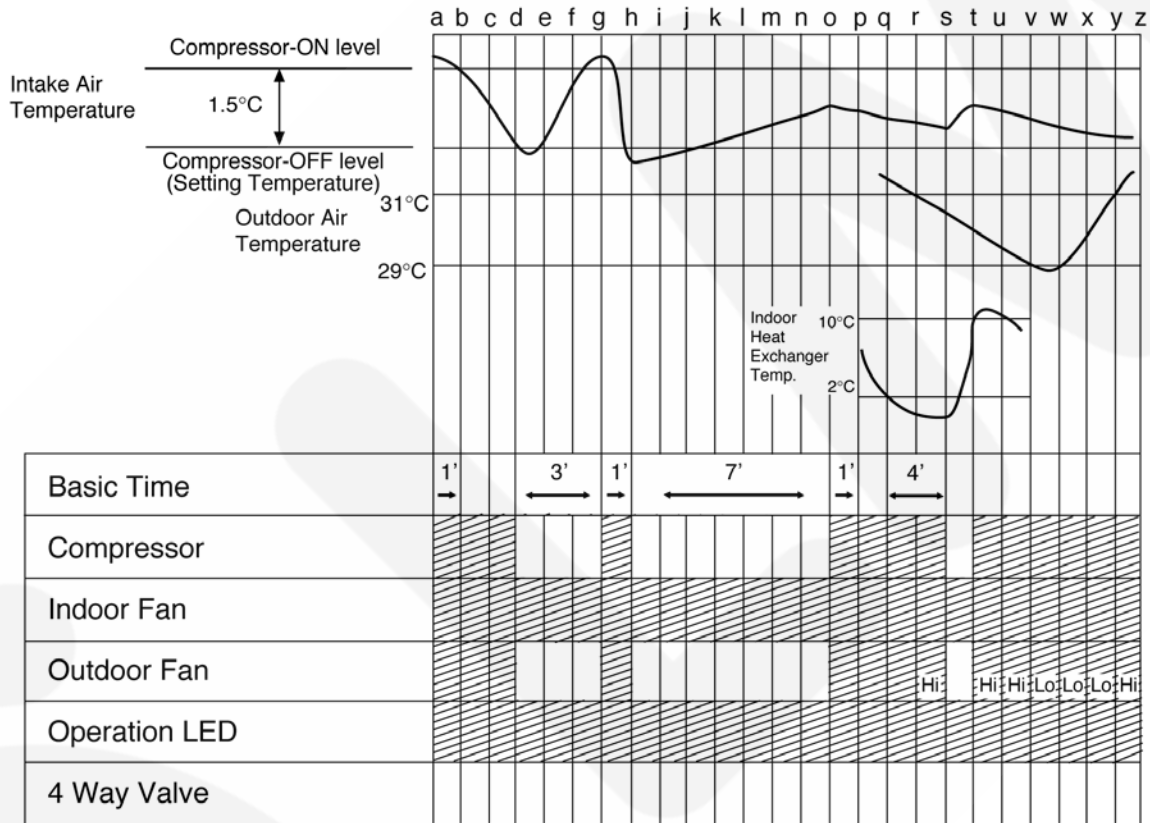

<Description of operation>

- d – g : Time Delay Safety Control (waiting for 3 minutes)
- g – h : 60 sec. Forced Operation
- h – o : 7 min. Time Save Control
- q – t : Anti Freezing Control
- v – y : Outdoor Fan Control

- Operation
- Stop

8.2. Soft Dry Operation

- Soft Dry operation can be set using remote control.
- Soft Dry operation is applied to dehumidify and to perform a gentle cooling to the room.
- This operation starts when the intake air temperature sensor reaches the setting temperature on the remote control.
- When operation begins, Soft Dry will be switched "ON" for a maximum 10 minutes, then Soft Dry operation will be turned "OFF" for a minimum 6 minutes. After that, the Soft Dry operation will be "ON" and "OFF" based on the setting temperature as shown in below figure.
- However after 3 minutes of compressor off, during Soft Dry "OFF" (within 6 minutes Soft Dry restart control), the indoor unit will start to operate at normal Cooling mode if the intake temperature is higher than Cooling "ON" point.

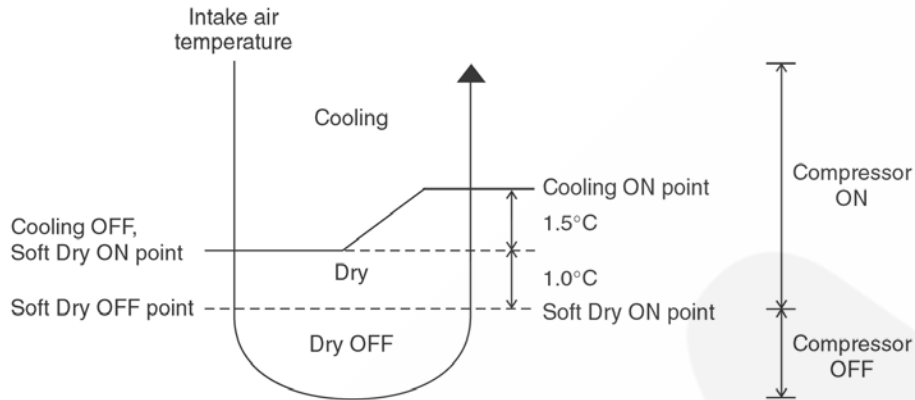

8.2.1. Soft Dry Operation Time Diagram

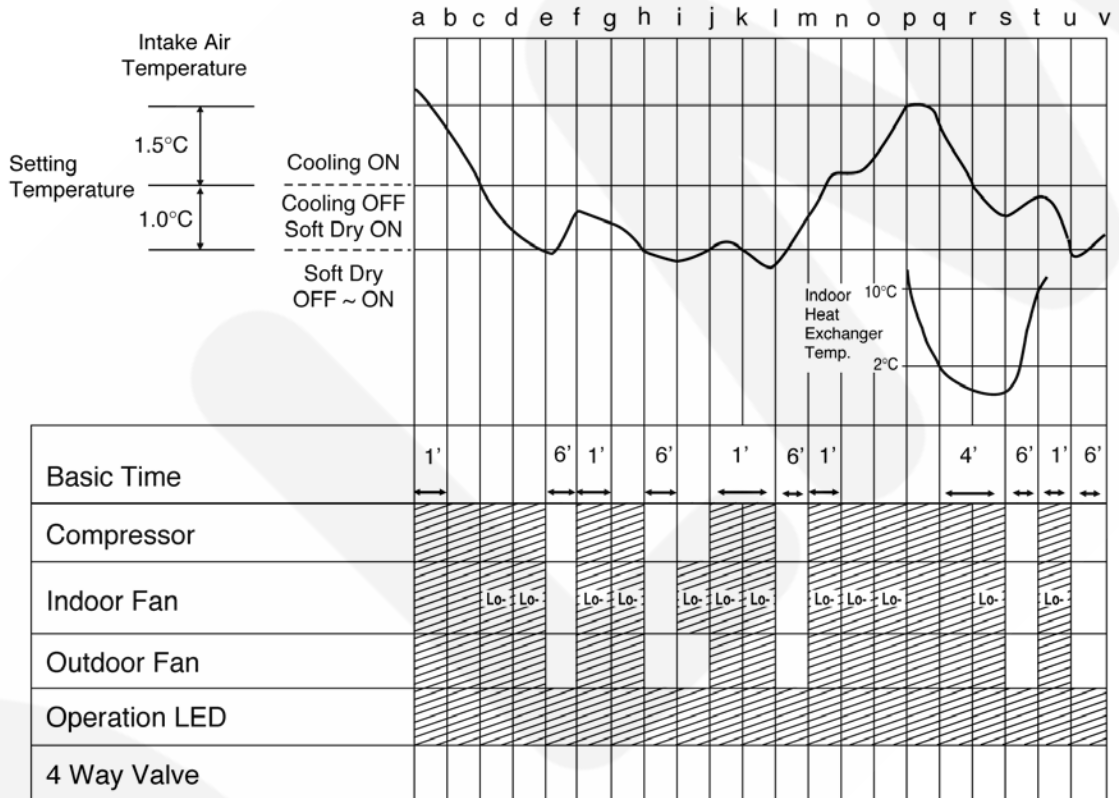

<Description of operation>

- a - c, p~r : Cooling Operation
- c - p : Soft Dry Operation
- e - f : Soft Dry OFF
- j - l : 60 sec. Forced Operation
- q - t : Anti Freezing Control

- Operation
- Stop

8.3. Automatic Operation

- Automatic operation can be set using remote control.
- This operation starts to operate with indoor fan at SLo speed for 20 seconds to judge the intake air temperature.
- After judged the temperature, the operation mode is determined by referring to the below standard.

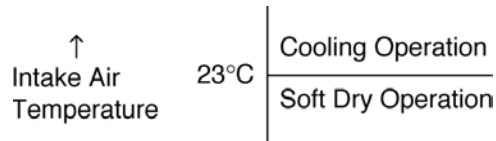

- Then, the unit start to operate at determined operation mode, until it is switched off using remote control, with the setting temperature as shown in below table.

	Setting Temperature (Standard)
Cooling Operation	25°C
Soft Dry Operation	22°C

- The setting temperature for all the operations can be changed one level up or one level down from the standard temperature as shown in below table by pressing on the temperature up or temperature down button at remote control.

Operation	Hi	(Standard)	Lo
	(+2°C)	(±0°C)	(-2°C)
Cooling	27°C	25°C	23°C
Soft Dry	24°C	22°C	20°C

- The operation mode judging temperature and standard setting temperature can be increased by 2°C permanently, by open the circuit of JX1 at indoor electronic controller.

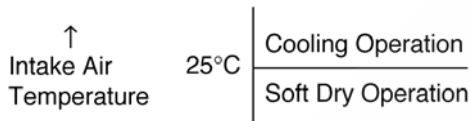

	Setting Temperature (Standard)
Cooling Operation	27°C
Soft Dry Operation	24°C

8.4. Operation Control

(For 8.5.1 to 8.5.7 information applies only to Cooling and Soft Dry Operation)

8.4.1. Restart Control (Time Delay Safety Control)

- When the thermo-off temperature (temperature which compressor stops to operate) is reached during:-
 - Cooling operation - the compressor stops for 3 minutes (minimum) before resume operation.
 - Soft Dry operation - the compressor stops for 6 minutes (minimum) before resume operation.
- If the operation is stopped by the remote control, the compressor will not turn on within 3 minutes from the moment operation stop, although the unit is turn on again within the period.
- This phenomenon is to balance the pressure inside the refrigerant cycle.

8.4.2. 60 Seconds Forced Operation

- Once the air conditioner is turned on, the compressor will not stop within 60 seconds in a normal operation although the intake air temperature has reached the thermo-off temperature. However, force stop by pressing the OFF/ON operation button at the remote control is permitted.
- The reason for the compressor to force operate at minimum 60 seconds is to allow the refrigerant oil run in a full cycle and return back to the outdoor unit.

8.4.3. 7 Minutes Time Save Control

- The compressor will start automatically if it has stopped for 7 minutes and the intake air temperature falls between the compressor ON temperature (A) and compressor OFF temperature (B) during the period.
- This phenomenon is to reduce the built up humidity inside a room.

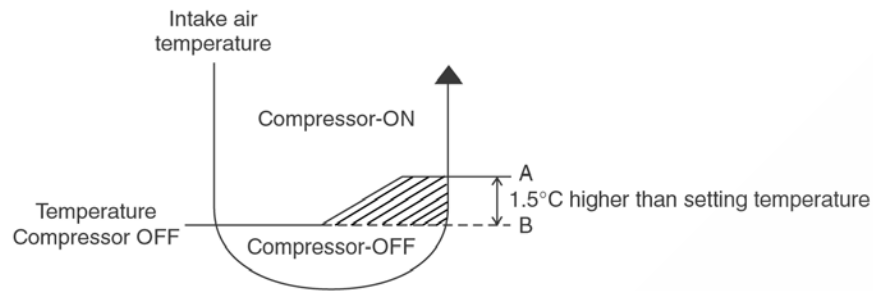

8.4.4. Anti-Freezing Control

- If the temperature of the indoor heat exchanger falls below 2°C continuously for 4 minutes or more, the compressor turns off. The fan speed setting remains the same.
- This phenomenon is to protect the indoor heat exchanger from freezing and to prevent higher volume of refrigerant in liquid form returning to the compressor.
- Compressor will restart again when the indoor heat exchanger temperature rises to 10°C (Recovery).
- Restart control (Time Delay Safety Control) will be applied in this Control if the recovery time is too short.

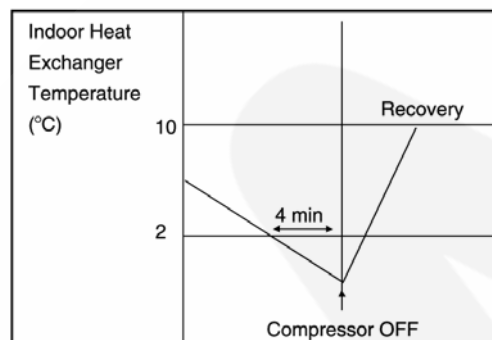

8.4.5. Compressor Reverse Rotation Protection Control

- If the compressor is operating continuously for 5 minutes or longer and the temperature difference between intake air and indoor heat exchanger is 2.5°C or less for continuous 2 minutes, compressor will stop and restart automatically.
- Time Delay Safety Control is activated before the compressor restart.



▲ T = Intake air temperature - Indoor heat exchanger temperature

- This is to prevent compressor from rotate reversely when there is an instantaneous power failure.

8.4.6. Starting Current Control

- When the compressor, outdoor fan motor and indoor fan motor are simultaneously started, the indoor fan motor will start to operate at 1.6 second later.
- The reason of the difference is to reduce the starting current flow.

8.4.7. Anti-Dew Formation Control

- Purpose is to prevent dew formation on indoor unit air discharge area.
- The following conditions occur for 30 minutes continuously, anti-dew formation will activate:
 - Remote Control setting temperature is less than 25°C.
 - Compressor is on.
 - Cooling operation mode.
 - Indoor fan motor operate at low fan speed or QLo.
- This control is cancelled immediately when above condition is changed.
- Anti-Dew formation is control by:
 1. Lo fan speed
Lo fan is changed to Lo+ fan

2. QLo fan speed

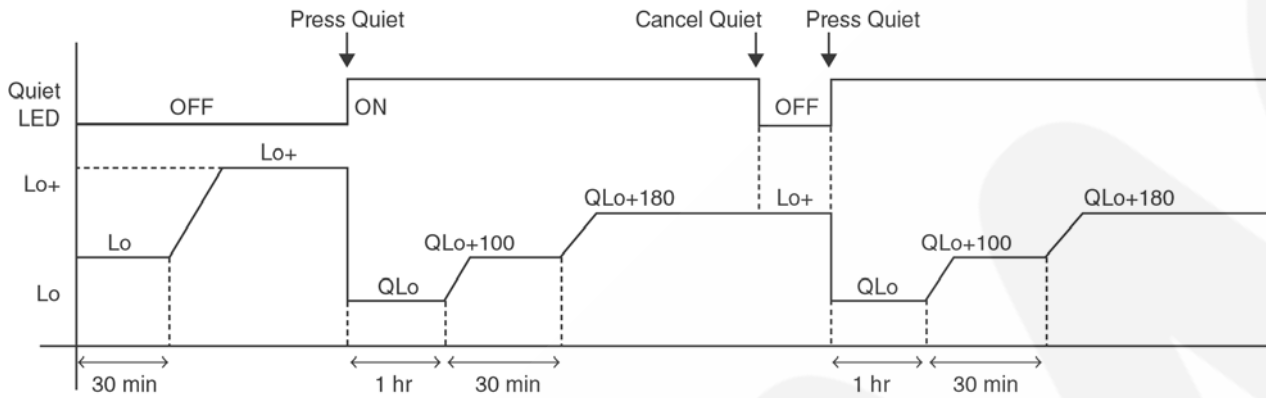

8.5. Indoor Fan Speed Control

- Indoor Fan Speed can be set using remote control.

8.5.1. Fan Speed Rotation Chart

Speed	CS-V24DKE	CS-V18DKE
Cool, Dry		
S Hi	1590	1420
Hi	1530	1360
Me	1390	1250
Lo+	1330	1220
Lo	1250	1150
Lo-	1100	980
S Lo	860	780
Q Hi	1430	1260
Q Me	1290	1150
Q Lo	1150	1050

8.5.2. Automatic Fan Speed Control

- When set to Auto Fan Speed, the fan speed is adjusted between maximum and minimum setting as shown in the table.
 - Fan speed rotates in the range of Hi, and Me and Lo-.
 - Deodorizing Control will be activated.

Tap			S Hi	Hi	Me	Lo+	Lo	Lo-	SLo	SSLo	Stop
Cooling	Normal	Manual	Hi	○							
			Me		○						
			Lo				○				
	Powerful	Auto		○	○			○			○
			Manual	○							
			Auto	○							
Soft Dry	Manual							○		○	
		Auto						○		○	
Auto Mode judgement									○		
Cooling	Quiet	Manual	QHi	(Hi)-100							
			QMe		(Me)-100						
			QLo				(Lo)-100				
		Auto		(Hi)-100	(Me)-100			○		○	
Soft Dry	Quiet	Manual						○		○	
		Auto						○		○	
Ion	Manual			○	○		○			○	
		Auto				○	○			○	

- Auto Fan Speed during cooling operation:
 - Indoor fan will rotate alternately between off and on as shown in below diagram.
 - At the beginning of each compressor start operation, indoor fan will increase fan speed gradually for deodorizing purpose.
 - For the first time the compressor operate, indoor fan will be switched to Hi fan speed from Lo- after 70 seconds from the start of compressor. This cause the room temperature to achieve the setting temperature quickly.
 - During compressor stop, indoor fan will operate at Lo- for the beginning 20 seconds to prevent higher volume of refrigerant in liquid form returning to the compressor.
 - After the compressor at turn off condition for 3 minutes, indoor fan will start to operate at Lo- to circulate the air in the room. This is to obtain the actual reading of the intake air temperature.
 - When the compressor resume operation, indoor fan will operate at Me fan speed (after 70 seconds from the restart of compressor) to provide comfort and lesser noise environment.

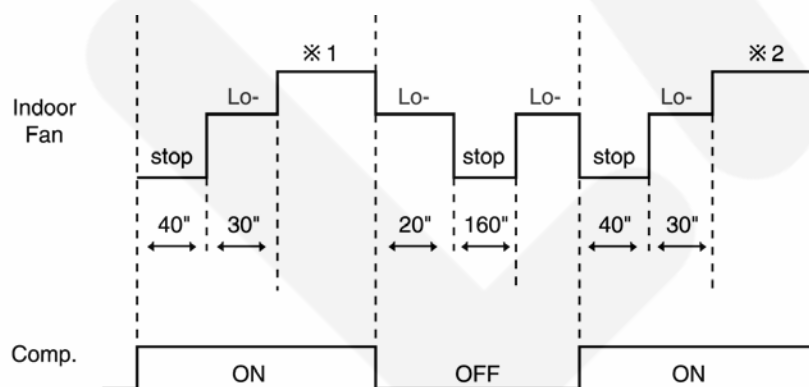

- * 1 Fan Speed is Hi until the compressor stops (when the room temperature reaches setting temperature).
- * 2 Fan Speed is Me after the compressor restarts.

- Auto Fan Speed during Soft Dry operation:

1. Indoor fan will rotate alternately between off and Lo-.
2. At the beginning of each compressor start operation, indoor fan will increase fan speed gradually for deodorizing purpose.
3. When compressor at turn off condition for 6 minutes, indoor fan will start fan speed at Lo- to circulate the air in the room. This is to obtain the actual reading of intake air temperature.

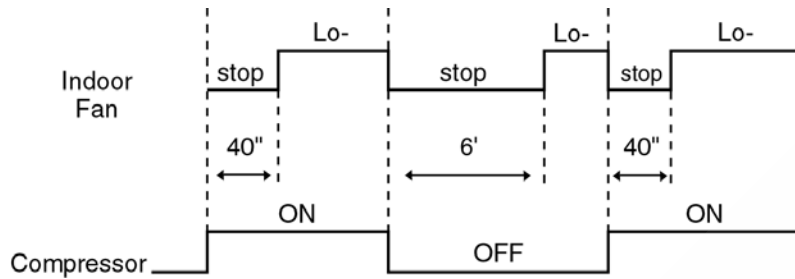

8.5.3. Manual Fan Speed Control

- Manual fan speed adjustment can be carried out by using the Fan Speed selection button at the remote control.
- There are 3 types of fan speed settings: Lo, Me, Hi.

8.6. Outdoor Fan Speed Control

- There is only one speed for outdoor fan motor (V18DK).
- There is 2 speed for outdoor fan motor, outdoor fan speed can be changed to Hi or Lo according to outdoor temperature (V24DK).
- When the air conditioner is turned on, the compressor and the outdoor fan will operate simultaneously.
- Likewise, both compressor and outdoor fan will stop at the same time if the unit is turned off.

8.7. Vertical Airflow Direction Control

8.7.1. Auto Control

(Cooling and Soft Dry Operation condition)

- When the vertical airflow direction is set to Auto using the remote control, the louver swings up and down as shown in the diagram.
- When stop operation using the remote control, the discharge vent is reset, and stop at the closing position.
- During Cooling operation or Soft Dry operation, indoor fan motor may stop to rotate at certain periods. At that condition, the louver will stop swinging and rest at the upper limit.
- During Anti-dew condensation prevention, Airflow Direction Auto-control angle change from 10°-38° to 10°-27° under Cooling and Soft Dry operation mode.

Cooling and Soft Dry Operation

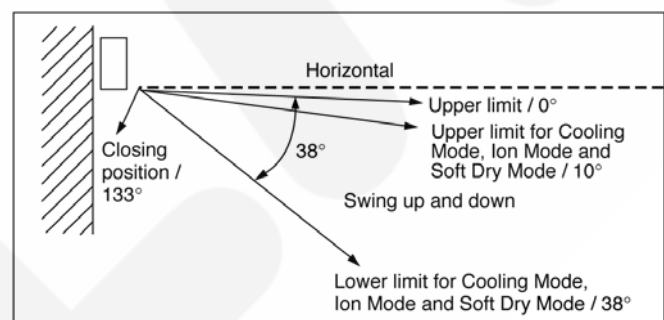

8.7.2. Manual Control

- When the vertical airflow direction is set to Manual using the remote control, the automatic airflow is released and the airflow direction louver move up and down in the range shown in the diagram.
- The louver can be adjusted by pressing the button to the desired louver position.
- When stop operation using the remote control, the discharge vent is reset, and stop at the closing position.
- During Anti-dew condensation prevention, Airflow Direction Manual control angle change from 10°, 14°, 18°, 22°, 27° to 10°, 13°, 16°, 19°, 22° under Cooling and Soft Dry operation mode.

Cooling and Soft Dry Operation

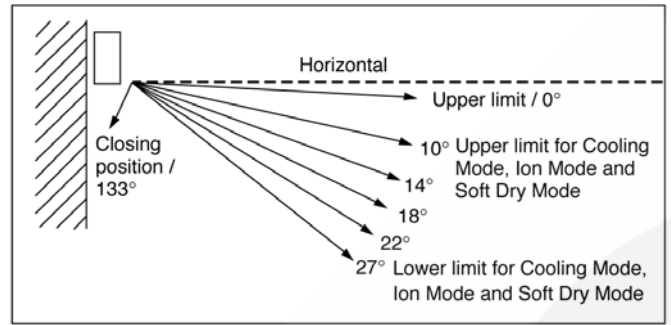

8.8. Horizontal Airflow Direction Control

8.8.1. Auto Control

- When the horizontal airflow direction is set to Auto using the remote control, the vanes swings left and right for Cooling and Soft Dry (0°-44°) as shown in the diagram.
- When stop operation using the remote control, the vanes is reset, and stop at the reset position.
- During Cooling operation or Soft Dry operation, indoor fan motor may stop to rotate at certain periods. At that condition, the vanes will stop swinging and rest at 22°.
- During Anti-dew condensation prevention, Airflow Direction Auto-control angle change from 0°-44° to 14°-30° under Cooling and Soft Dry operation mode.

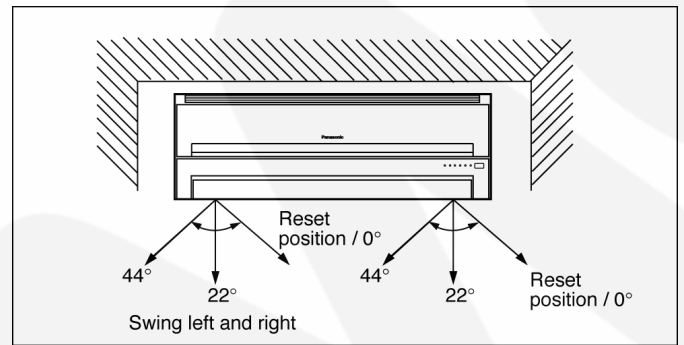

8.8.2. Manual Control

- When the horizontal airflow direction is set to Manual using the remote control, the automatic airflow is released and the airflow direction vane move left and right in the range shown in the diagram.

The louver can be adjusted by pressing the button to the desired vane position.

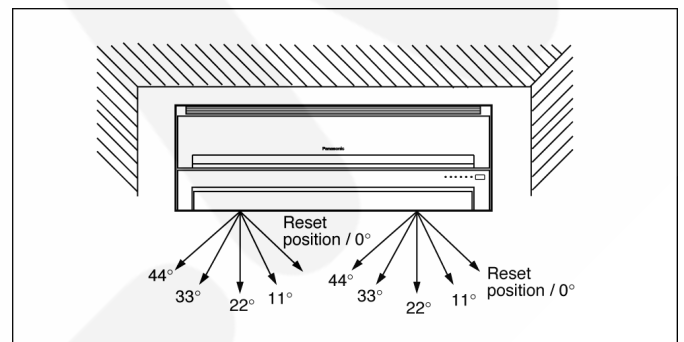

- When stop operation using the remote control, the vanes is reset, and stopped at reset position.
- During Anti-dew condensation prevention, Airflow Direction Manual control angle change from 0°, 11°, 22°, 33°, 44° to 14°, 18°, 22°, 26°, 30° under Cooling and Soft Dry operation mode.

8.9. Powerful Operation

- The Powerful operation is to achieve the setting temperature quickly.

(Cooling and Soft Dry Operation condition)

- When Powerful operation is set, the setting temperature will be automatically decreased 3°C internally against the present setting temperature (Lower temperature limit: 16°C).
- This operation automatically will be running under SHi Fan Speed (Cooling).
- Vertical Airflow Direction:-
 - In "Manual" setting, the vane will automatically shift down 10° lower than previous setting.
 - In "Auto" setting, the vane will automatically swing up and down. However the lower limit will be shifted 10° downward.
- Powerful operation stops when:-
 - Powerful operation has operate for 15 minutes.
 - Powerful button is pressed again.
 - Quiet button is pressed.
 - Stopped by OFF/ON operation button.
 - Timer OFF activates.
 - Operating mode is changed.

8.10. Quiet Operation

- The Quiet operation is to provide quiet cooling/heating operation condition compare to normal operation.

(Cooling and Soft Dry Operation condition)

- Once the Quiet Mode is set at the remote control, Quiet Mode LED illuminates. The sound level will reduce either around 2 dB(A) for Lo fan speed or 3 dB(A) for Hi/Me fan speed against the present sound level operation.
- Dew formation become severe at Quiet Lo cool, therefore Quiet Lo cool is operated only 1hr 30 min (1hr QLo, 30 min QLo + 100 rpm). After that, it goes back to QLo +180 rpm (However Quiet LED remains on).
- Manual Fan Speed:-
 - RPM control during Lo cool

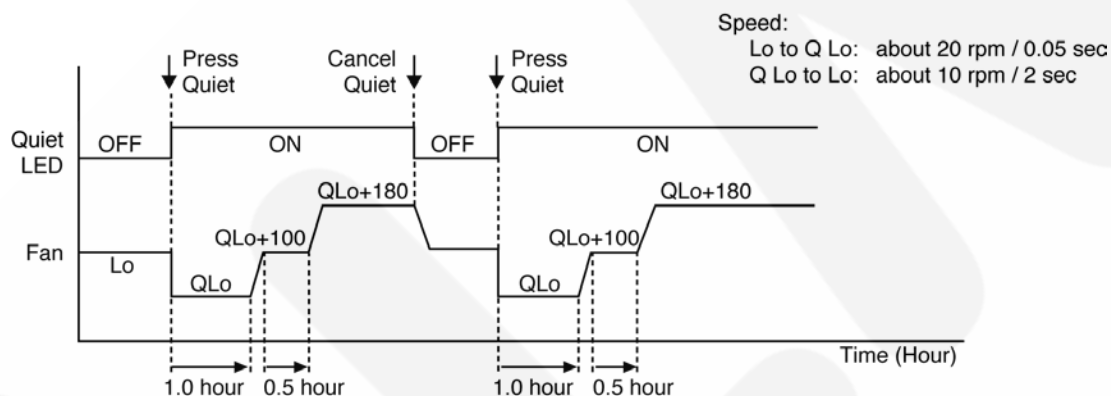

- RPM control during Hi & Me cool

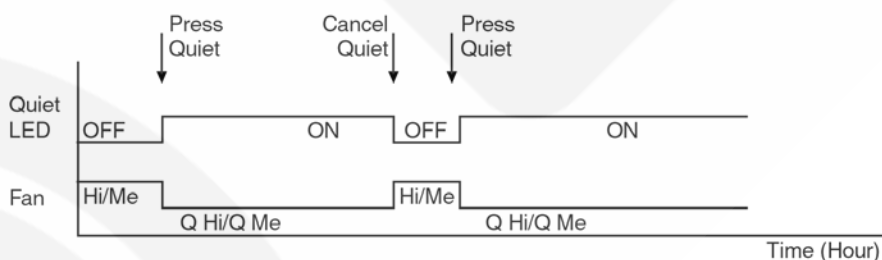

- Auto Fan Speed:-

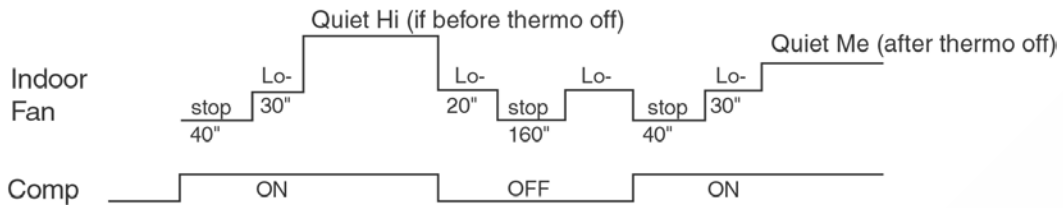

- Quiet operation stops when:-
 - Quiet/Powerful button is pressed again.
 - Stopped by OFF/ON operation button.
 - Timer OFF activates.

8.11. Ionizer Operation

- The Ionizer operation is to provide fresh air effect to user by producing minus ion in discharge air.

8.11.1. Operation Control

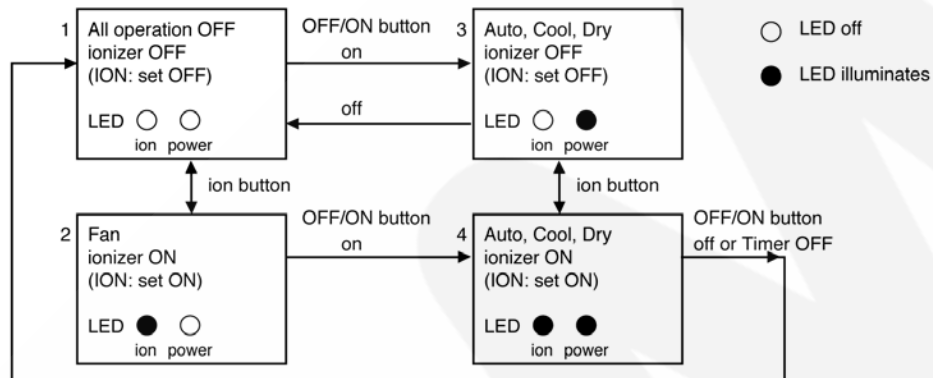

1. Ionizer individual operation

- When air-conditioner unit is at "OFF" condition (standby) and ION operation button at the remote control is pressed, the Ionizer and Fan operations will turn on. Only ION LED will illuminate. Power LED maintain off. (1 → 2)
- Ionizer individual operation can be turned off by pressing the ION button again. (2 → 1)
- Fan speed can be adjusted later by customer during this operation.

Indoor fan mode	Fan speed
Manual	Hi, Me, CLo
Auto	between Lo+ & Lo at the pattern shown below

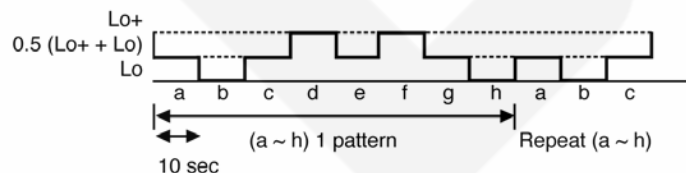

- Vertical airflow direction can be adjusted using remote control during Ionizer individual operation.
- During Ionizer individual operation, operated mode (Auto, Cool, Dry) can be activated by turning on the OFF/ON operation button. (2 → 4)
- If power failure occur during Ionizer individual operation, after power resume, Ionizer operation will be activated immediately.
- When the Ionizer circuit feedback process error occur for 24 times (about 11hr 30 min.), Ionizer and Fan operations will turn off with ION LED blinks continuously.
(For details, please refer to Ionizer Error detection control)

2. Operation mode & Ionizer operation.

- a. When air-conditioner unit is at "ON" condition and ION operation button at the remote control is pressed, the Ionizer operation will turn on. ION & Power LED will illuminate. (3 → 4)
- b. Ionizer operation stops when:
 - ION operation button is press again.
 - Stopped by OFF/ON operation button.
 - Timer OFF activates.
 - Ionizer circuit feedback signal shows error.
- c. Ionizer operation status is not memorized when the air conditioner has been switched off. The air-conditioner will operate without ionizer operation when it is turned on again. However, if power failure occurs during Ionizer operation together with Cooling operation, air-conditioner will start to operate at Cooling operation with Ionizer operation when the power is resumed.

8.11.2. Error Detection Control

- The error detection control is to inform user that error occurs at ionizer system and repairing job will be needed.
- There are two types of error detection control:
 - a. When Ionizer is ON
 - If ionizer feedback = Lo for 24 times within 11hr 30min, ION LED blinks continuously.
 - b. When ionizer is OFF
 - If ionizer feedback = Hi, ION LED blinks continuously.
- During ionizer at breakdown condition, if ionizer feedback voltage = Lo (become normal), ION LED will stop blinking.
- The error detection control can be reset by:
 - i) Pressing the OFF/ON operation button to switch the operation OFF.
 - ii) Pressing the Auto Operation button to force the operation OFF.
 - iii) Setting the OFF Timer to stop the operation (Not applicable when ionizer is OFF).

8.12. Timer Control

- There are 2 types of timer, ON and OFF timer.
- Both ON and OFF timer can be set by pressing ON or OFF button respectively.
- By pressing ON/OFF operation button, ON Timer or OFF Timer will not be cancelled.
- To cancel the previous timer setting, press CANCEL button.
- To activate the previous timer setting, press SET button once again.
- If main power supply is switched off, the Timer setting will be cancelled.

8.12.1. ON Timer

- When ON Timer is set by using the remote control, the unit will start to operate slightly before the set time, so that the room will reach nearly to the set temperature by the set time.
- For Cooling and Soft Dry operation, the operation will start 15 minutes before the set time.
- For Automatic operation, the indoor fan will operate at SLo speed for 20 seconds, 30 minutes before the set time to detect the intake air temperature to determine the operation mode. The operation indication lamp will blink at this time.

8.12.2. OFF Timer

- When OFF Timer is set by using the remote control, the unit will stop operate according to the desired setting.

8.13. Random Auto Restart Control

- If there is a power failure during operation, the air conditioner will automatically restart after 3 to 4 minutes when the power is resumed.
- It will start with previous operation mode and airflow direction.
- If there are more than one air conditioner unit in operation and power failure occur, restart time for each unit to operate will be decided randomly using 4 parameters:- intake air temperature, setting temperature, fan speed and air swing louver position.
- This Random Auto Restart Control is not available when Timer is set.
- This control can be omitted by open the circuit of JX2. (Refer Circuit Diagram)

8.14. Remote Control Signal Receiving Sound

- Long beep sound will be heard when:-
 - Stopping the air conditioner using OFF/ON operation button.
 - Stopping the Quiet Mode.
 - Stopping the Powerful Mode.
 - Stopping the Ion Mode.
- Short beep sound will be heard for others setting.

9 Operating Instructions

■ Definition

To prevent personal injury, injury to others and property damage, the following instructions must be followed.

Incorrect operation due to failure to follow instructions will cause harm or damage, the seriousness of which is classified as below:



Warning

This sign warns of death or serious injury.



Caution

This sign warns of injury or damage to property.

The instructions to be followed are classified by the following symbols:



This symbol denotes an action that is PROHIBITED.



These symbols denote actions that are COMPULSORY.

Thank you for purchasing Panasonic Air Conditioner

SAFETY PRECAUTIONS

Installation Precautions



Warning

Do not install, remove and reinstall the unit by yourself.

- Improper installation will cause leakage, electric shock or fire. Please consult an authorized dealer or specialist for the installation work.



Caution

- This air conditioner must be earthed. Improper grounding will cause electric shock.
- Ensure that the drainage piping is connected properly. Otherwise, water will leak.
- Current leakage protection equipment must be installed. Otherwise, electric shock or fire may occur.
- Do not install the unit in a potentially explosive atmosphere.

Operation Precautions



Warning

- Do not share power outlet.
- Do not modify power cord.
- Do not use an extension cord.
- Do not operate with wet hands.
- Do not operate or stop the unit by inserting or pulling out the power plug.
- Do not insert finger or other objects into the indoor or outdoor unit.
- Do not attempt to repair the unit by yourself.
- Do not use rechargeable (Ni-Cd) batteries.
- Keep the remote control away from infants and small children to prevent them from accidentally swallowing the batteries.
- Insert the power plug properly.
- Use specified supply cord.
- If the supply cord is damaged or needed to be replaced, it must be replaced by the manufacturer or its service agent or a similarly qualified person in order to avoid a hazard.
- Remove the batteries if the unit is not going to be used for a long period of time.
- New batteries of the same type must be inserted following the polarity stated to prevent malfunction of the remote control.
- In case of emergency or abnormal condition (burnt, smell, etc) occurs, turn off the power supply and unplug.



- Do not pull the cord to disconnect the plug.
- Do not wash the unit with water, benzene, thinner or scouring powder.
- Do not use for other purposes such as preservation of food.
- Do not use any combustible equipment at airflow direction.
- Do not sit or place anything on the indoor or outdoor unit.
- Do not expose directly to cold air for a long period.



- Ventilate the room regularly.
- Pay attention as to whether the installation rack is damaged after long period of usage.



- Switch off the power supply and unplug before cleaning or servicing.



- Turn off the power supply and unplug if the unit is not used for a long period of time.

Safety Regulation

The appliance is not intended for use by young children or infirm person without supervision. Young children should be supervised to ensure that they do not play with the appliance.

Replacement or installation of power plugs shall be performed by authorized/qualified personnel only. The wires in this mains lead are coloured in accordance with the following code:

Terminals	wires	colours (GB Standard)
L	live	brown
N	neutral	blue
E	earth	green-yellow

Different countries may have different colour coding for the wires.

Operation Condition (°C)

Use this air conditioner under the following temperature range.

DBT: Dry Bulb Temperature WBT: Wet Bulb Temperature	Indoor		Outdoor	
	DBT	WBT	DBT	WBT
Maximum Temperature	32	23	43	26
Minimum Temperature	16	11	16	11

Note: The illustrations in this manual are for explanation purposes only and may differ from the actual unit. It is subjected to change without notice for future improvement.

PRODUCT OVERVIEW

Indoor Unit

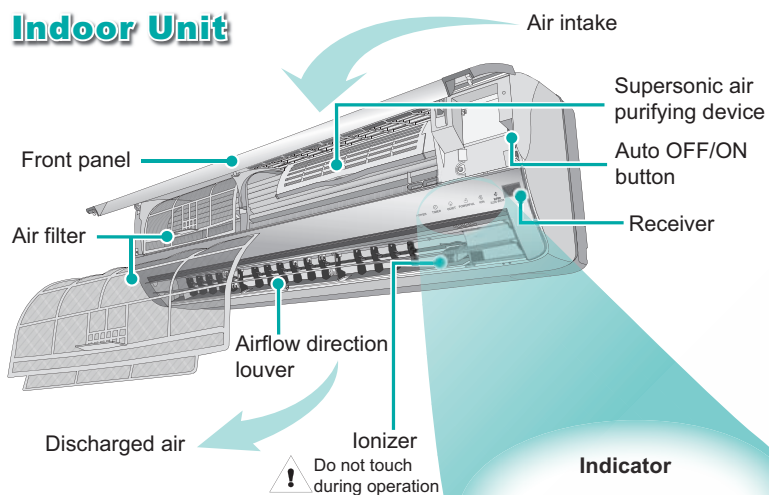

Outdoor Unit

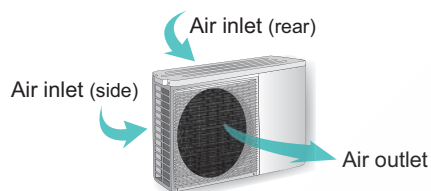

Remote Control

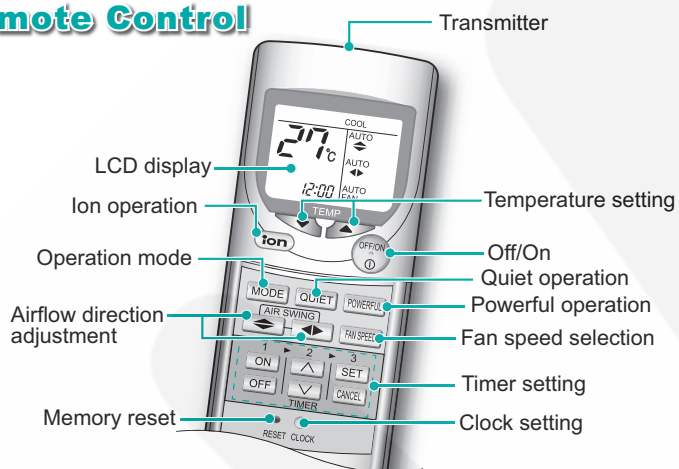

About

Remote Control Preparation

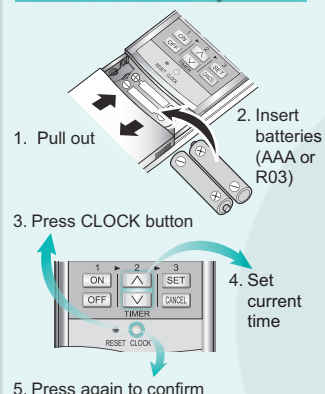

- 5. Press again to confirm
- Timer operation will be based on current time set.
- The batteries can be used for approximately 1 year.
- The batteries must be recycled or disposed of properly.

Remote Control Signal

- Make sure it is not obstructed.
- Maximum distances: 10m.
- Certain fluorescent lights may interfere with signal transmission. Consult your dealer.

Auto OFF/ON Button

- To operate the unit if the remote control is misplaced or malfunctioning.

Action	Operation mode
Press once	Automatic Operation
Press until "beep" sound	Cooling Operation

- To OFF, press again the Auto OFF/ON button.
- To switch the remote control signal receiving sound off or on.
 1. Press until "beep" sound and release.
 2. Press again until "beep-beep" sound and release.
 3. Press to switch the sound off or on.
(Long "beep" - OFF; short "beep" - ON)

Troubleshooting



- Operation delayed for few minutes after restart. ➤ This is a normal self protection control.
- Sound like water flowing during operation. ➤ Caused by refrigerant flow inside.
- Mist emerges from indoor unit. ➤ Condensation effect due to cooling process.
- Noisy during operations. ➤ Installation work could be slanted or front panel didn't close properly.
- Remote control/display does not work. ➤ Check whether batteries are correctly inserted or need replacement.
- The unit cannot operate. ➤ Check either circuit breaker is tripped, power plug is inserted correctly or timer is used correctly.
- Outdoor unit emits water/steam. ➤ Condensation or evaporation happens at piping surface.

■ Operation Details

AUTO - Automatic Operation

- The unit will automatically select the operation mode according to the room temperature.
- Once the operation mode is selected, the unit will operate at the standard setting temperature as shown:

Room temperature	Operation mode	Standard setting temperature
23°C & above	Cool	25°C
Below 23°C	Dry	22°C

- You may press or button to change the standard setting temperature to "HI" or "LO" as shown:

Operation mode	HI	LO
Cool	27°C	23°C
Dry	24°C	20°C

COOL - Cooling Operation

- Enables you to enjoy the cooling effect at your preferred setting temperature.
- The range of temperature can be selected from 16°C ~ 30°C.

DRY - Soft Dry Operation

- Enables you to set the desired temperature at low fan speed which provides you with the dehumidifying surroundings.
- The range of temperature can be selected from 16°C ~ 30°C.

HOW TO OPERATE

Auto, Cool, Dry

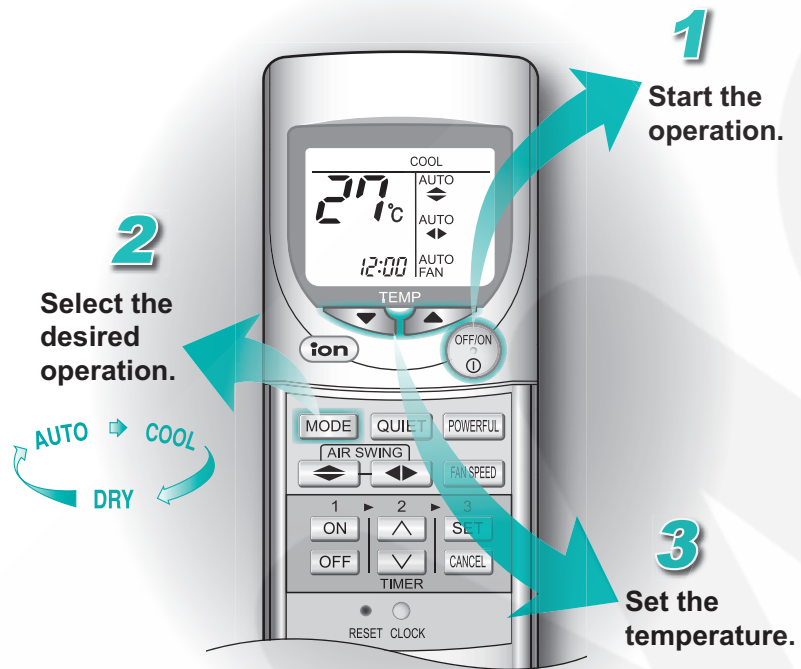

- Supersonic air purifying device (super alleru-buster) operates automatically while the air conditioner is switched on.
- Powerful, Quiet and Ion operations could be activated in all operation modes.
- Press button again to stop the operation.

Hint

- To save electricity, close the curtains when using air conditioner to prevent sunlight and heat from coming in.

Troubleshooting

- The room has a peculiar odour.
 - This may be a damp smell emitted by the wall, carpet, furniture or clothing in the room.
- Air conditioner does not cool efficiently.
 - Ensure the temperature has been set correctly.
 - Ensure windows and doors have been closed properly.
 - Ensure filters are cleaned or replaced when necessary.
 - Ensure inlet and outlet vents of outdoor unit have not been obstructed.

HOW TO OPERATE

Powerful, Quiet, Ion, Fan Speed, Air Swing

ION
Enables ion operation.



QUIET
Enables quiet operation.

POWERFUL
Enables powerful operation.

AIR SWING
Adjust the vertical or horizontal airflow direction louver.

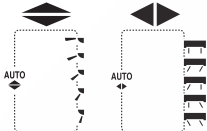

- Ion operation could be activated independently.
- Powerful and Quiet operations could not be activated at the same time.
- Powerful, Quiet and Ion operations could be cancelled by pressing the respective button again.

FAN SPEED
Select fan speed.



Operations Details

POWERFUL

- To achieve setting temperature quickly. It will operate for 15 minutes and return to the previous setting.

QUIET

- To provide a quiet environment.

ION

- To provide fresh air effect by producing negative ions.

FAN SPEED

- To provide you with the various fan speed selections.
- There are 3 levels of fan speed in addition to automatic fan speed.
- Automatic fan speed:
The speed of the indoor fan is automatically adjusted according to the operation.

AIR SWING

- ◆ To ventilate air in the room.
- There are 5 selections in addition to automatic vertical air flow direction.
- If automatic vertical airflow direction has been set, the louver swings up and down automatically.

- ◆ To ventilate air in the room.
- There are 5 selections in addition to automatic horizontal air flow direction.
- If automatic horizontal airflow direction has been set, the louver swings left and right automatically.

- Please do not adjust the vertical and horizontal airflow direction louver manually.

Hints



- If you wish to have the cool air blowing directly on you, set the airflow direction downward but not for an excessive length of time, as it may harm your health.
- Approximately 10% of electricity can be saved if you set the temperature 1°C higher than the desired temperature during cooling operation.

Troubleshooting



- ION indicator on the indoor unit is blinking. ➤ Press ION button twice. If the indicator is still blinking, please consult the dealer.
- Indoor fan stops occasionally during Automatic Fan Speed setting. ➤ This is an advanced feature that helps to remove smell from the surrounding area during operation.

■ Operation Details

TIMER

- Use the ON timer to turn on the air conditioner at the desired time. This will give you a cooling environment, e.g. when you return from work or wake up.
- When the ON timer is set, operation will start 15 minutes before the actual set time.
- Use the OFF timer to stop the air conditioner operation at the desired time. This can save electricity while you are going out or sleeping.
- The set timer will repeat daily once it is set.
- If there is a power failure, you can press SET button to restore the previous setting once the power is resumed.
- If the timer is cancelled, you can restore the previous setting by pressing SET button.

HOW TO OPERATE

Timer

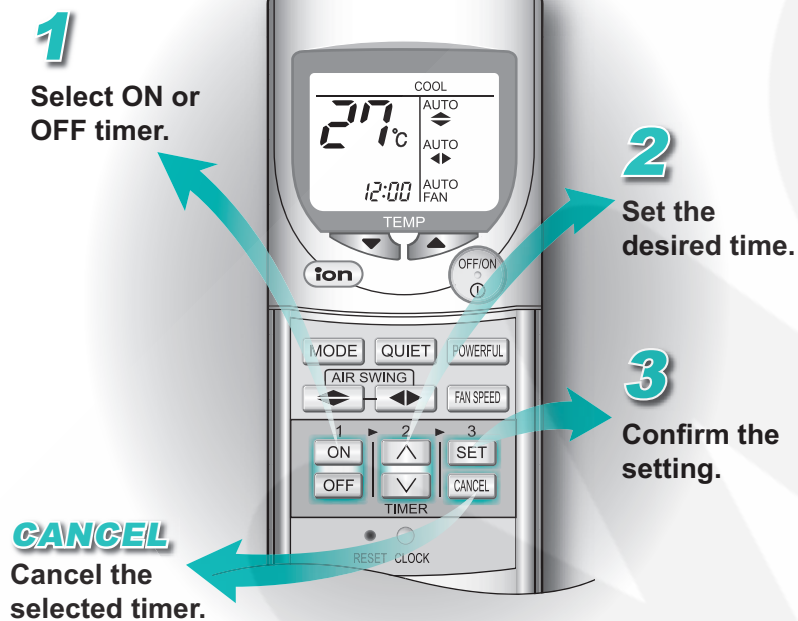

- Ensure the clock on the remote control has been set correctly.
- You could use the ON and OFF timers at the same time.
- To cancel either the ON or OFF timer, press **ON** or **OFF**, then press **CANCEL**.



Hint

- Press CLOCK more than 10 seconds to change the time format from 24 hours to AM/PM format.
- For your convenience, you could set the air conditioner to operate automatically by using both ON and OFF timer.



Troubleshooting

- **TIMER** indicator always on. ➤ Timer is activated and the setting will repeat itself daily.
- **POWER** indicator is blinking 15 minutes before ON timer is activated. ➤ The unit is determining the operation mode by sensing the room temperature. This happens when it has been set to AUTO operation mode.

CARE & CLEANING



Switch off the power supply before cleaning

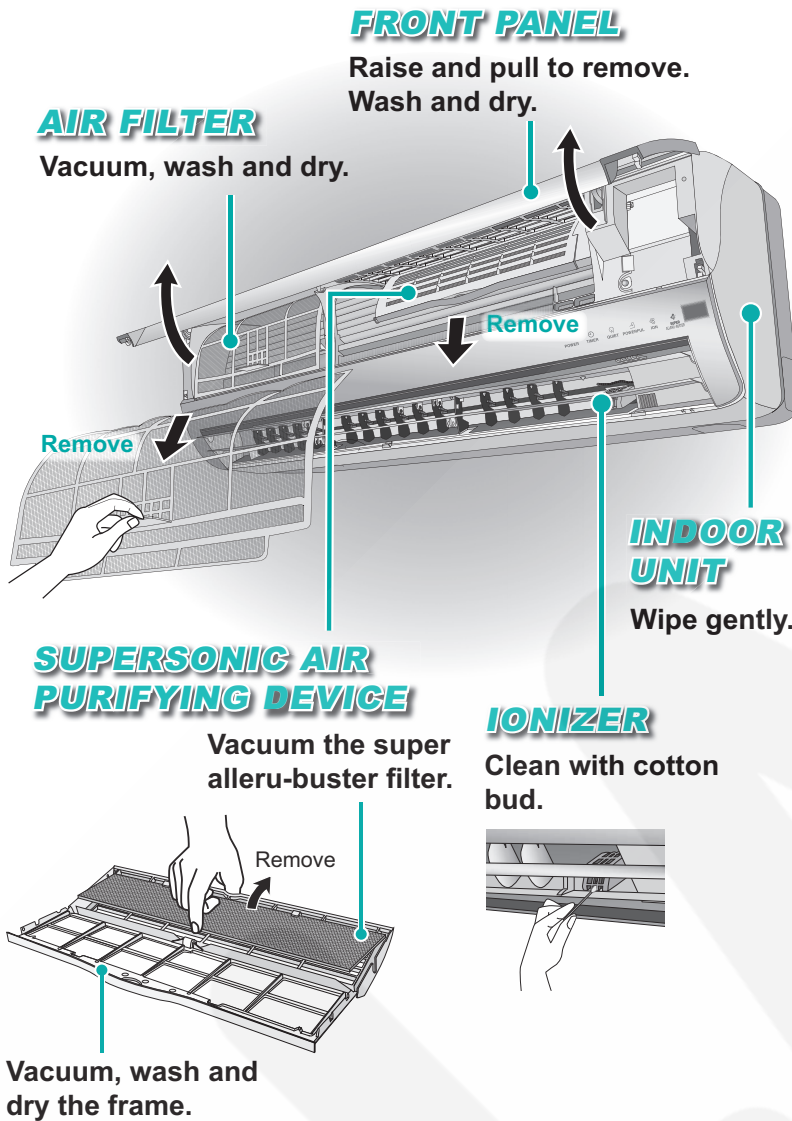

Washing Instructions

- Do not use benzene, thinner or scouring powder.
- Use soaps or neutral household detergent (\approx pH7) only.
- Do not use water with temperature higher than 40°C.

INDOOR UNIT

- Wipe the unit gently with a soft, dry cloth.

AIR FILTER

- It is recommended to clean the air filters once every 2 weeks.
- Purchase the replacement filter if it is damaged.

Part no.: CWD001137 (Left)

CWD001138 (Right)

SUPER ALLERU-BUSTER

- It is recommended to clean the filter every 6 months.
- Replace the filter every 3 years or purchase the replacement filter if it is damaged.

Part no.: CZ-SA13P

IONIZER

- It is recommended to clean the ionizer every 6 months.

Preparation for extended Non-operation

- Operate the unit for 2~3 hours using ion operation to dry the internal parts.
- Turn off the power supply and unplug.
- Remove the remote control batteries.

Pre-season Inspection

- This inspection is recommended before operating the air conditioner at every season.
- Check if the remote control batteries needed to be replaced.
- Ensure there is no obstruction at all air intake and outlet vents.
- After the start of operation for 15 minutes, it is normal if the temperature differences between air intake and outlet vents at indoor unit is:-

Operation	Temperature
Cooling	$\geq 8^{\circ}\text{C}$



Hints



- Clean the filter regularly as dirty filters will cause unpurified air, low cooling capacity, unpleasant smells and higher energy consumption.
- The unit will become dirty and the performance of the unit will decrease after used for several seasons. Please consult an authorized dealer to perform seasonal inspections in addition to regular cleaning.

10 Installation Instructions

Required tools for Installation Works			
1. Philips screw driver	5. Spanner	9. Gas leak detector	13. Multimeter
2. Level gauge	6. Pipe cutter	10. Measuring tape	14. Torque wrench 18 N.m (1.8 kgf.m) 55 N.m (5.5 kgf.m) 65 N.m (6.5 kgf.m)
3. Electric drill, hole core drill ($\phi 70$ mm)	7. Reamer	11. Thermometer	15. Vacuum pump
4. Hexagonal wrench (4 mm)	8. Knife	12. Megameter	16. Gauge manifold

10.1. Safety Precautions





- Read the following “SAFETY PRECAUTIONS” carefully before installation.
- Electrical work must be installed by a licensed electrician. Be sure to use the correct rating of the power plug and main circuit for the model to be installed.
- The caution items stated here must be followed because these important contents are related to safety. The meaning of each indication used is as below. Incorrect installation due to ignoring of the instruction will cause harm or damage, and the seriousness is classified by the following indications.

 WARNING	This indication shows the possibility of causing death or serious injury.
 CAUTION	This indication shows the possibility of causing injury or damage to properties only.

The items to be followed are classified by the symbols:

	Symbol with background white denotes item that is PROHIBITED from doing.
---	--

- Carry out test running to confirm that no abnormality occurs after the installation. Then, explain to user the operation, care and maintenance as stated in instructions. Please remind the customer to keep the operating instructions for future reference.

 WARNING	
1. Engage dealer or specialist for installation. If installation done by the user is defective, it will cause water leakage, electrical shock or fire.	
2. Install according to this installation instruction strictly. If installation is defective, it will cause water leakage, electrical shock or fire.	
3. Use the attached accessories parts and specified parts for installation. Otherwise, it will cause the set to fall, water leakage, fire or electrical shock.	
4. Install at a strong and firm location which is able to withstand the set's weight. If the strength is not enough or installation is not properly done, the set will drop and cause injury.	
5. For electrical work, follow the local national wiring standard, regulation and this installation instruction. An independent circuit and single outlet must be used. If electrical circuit capacity is not enough or defect found in electrical work, it will cause electrical shock or fire.	
6. Use the specified cable (2.5 mm ²) and connect tightly for indoor/outdoor connection. Connect tightly and clamp the cable so that no external force will be acted on the terminal. If connection or fixing is not perfect, it will cause heat-up or fire at the connection.	
7. Wire routing must be properly arranged so that control board cover is fixed properly. If control board cover is not fixed perfectly, it will cause heat-up at connection point of terminal, fire or electrical shock.	
8. When carrying out piping connection, take care not to let air substances other than the specified refrigerant go into refrigeration cycle. Otherwise, it will cause lower capacity, abnormal high pressure in the refrigeration cycle, explosion and injury.	
9. Do not damage or use unspecified power supply cord. Otherwise, it will cause fire or electrical shock.	
10. <ul style="list-style-type: none"> • When connecting the piping, do not use any existing (R22) pipes and flare nuts. Using such same may cause abnormally high pressure in the refrigeration cycle (piping), and possibly result in explosion and injury. Use only R410A materials. • Thickness of copper pipes used with R410A must be more than 0.8 mm. Never use copper pipes thinner than 0.8 mm. • It is desirable that the amount of residual oil is less than 40 mg/10 m. 	
11. Do not modify the length of the power supply cord or use of the extension cord, and do not share the single outlet with other electrical appliances. Otherwise, it will cause fire or electrical shock.	









⚠ CAUTION

- | | |
|--|---|
| 1. This equipment must be earthed. It may cause electrical shock if grounding is not perfect. | |
| 2. Do not install the unit at place where leakage of flammable gas may occur. In case gas leaks and accumulates at surrounding of the unit, it may cause fire. |  |
| 3. Carry out drainage piping as mentioned in installation instructions. If drainage is not perfect, water may enter the room and damage the furniture. | |

ATTENTION

- | |
|--|
| 1. Selection of the installation location.
Select an installation location which is rigid and strong enough to support or hold the unit, and select a location for easy maintenance. |
| 2. Power supply connection to the room air conditioner.
Connect the power supply cord of the room air conditioner to the mains using one of the following method.
Power supply point shall be the place where there is ease for access for the power disconnection in case of emergency.
In some countries, permanent connection of this room air conditioner to the power supply is prohibited. <ol style="list-style-type: none"> 1. Power supply connection to the receptacle using a power plug.
Use an approved 16A power plug with earth pin for 2.0HP (V18DK, W18DK) and 20A for 2.5HP (V24DK, W24DK) for the connection to the receptacle. 2. Power supply connection to a circuit breaker for the permanent connection. Use an approved 16A circuit breaker 2.0HP (V18DK, W18DK) and 20A for 2.5HP (V24DK, W24DK) for the permanent connection. It must be a double pole switch with a minimum 3.5 mm contact gap. |
| 3. Do not release refrigerant.
Do not release refrigerant during piping work for installation, reinstallation and during repairing a refrigeration parts. Take care of the liquid refrigerant, it may cause frostbite. |
| 4. Installation work.
It may need two people to carry out the installation work. |
| 5. Do not install this appliance in a laundry room or other location where water may drip from the ceiling, etc. |

Attached accessories

No.	Accessories part	Qty.	No.	Accessories part	Qty.
1	Installation plate 	1	5	Remote Control holder 	1
2	Installation plate fixing screw 	6	6	Remote Control holder fixing screw 	2
3	Remote control 	1	7	Super alleru-buster filter 	1
4	Battery 	2	8	Drain elbow (W18DK, W24DK) 	1

Applicable piping kit

CZ-4F5, 7, 10BP (V18DK, W18DK)

CZ-52F5, 7, 10BP (V24DK, W24DK)

Select the best location

INDOOR UNIT

- There should not be any heat source or steam near the unit.
- There should not be any obstacles blocking the air circulation.
- A place where air circulation in the room is good.
- A place where drainage can be easily done.
- A place where noise prevention is taken into consideration.
- Do not install the unit near the door way.
- Ensure the spaces indicated by arrows from the wall, ceiling, fence or other obstacles.
- Recommended installation height for indoor unit shall be at least 2.3 m.

OUTDOOR UNIT

- If an awning is built over the unit to prevent direct sunlight or rain, be careful that heat radiation from the condenser is not obstructed.
- There should not be any animal or plant which could be affected by hot air discharged.
- Keep the spaces indicated by arrows from wall, ceiling, fence or other obstacles.
- Do not place any obstacles which may cause a short circuit of the discharged air.
- If piping length is over 7.5m, additional refrigerant should be added as shown in the table.

Model	Piping size		Rated Length (m)	Max. Elevation (m)	Max. Piping Length (m)	Additional Refrigerant (g/m)
	Gas	Liquid				
V18DK	1/2"	1/4"	5	20	25	20
V24DK	5/8"	1/4"	5	20	25	30
W18DK	1/2"	1/4"	5	20	25	20
W24DK	5/8"	1/4"	5	20	25	30

Example: For W24DK

If the unit is installed at 10 m distance, the quantity of additional refrigerant should be 75 g..... (10 - 7.5) m x 30 g/m = 75 g

Indoor/Outdoor Unit Installation Diagram

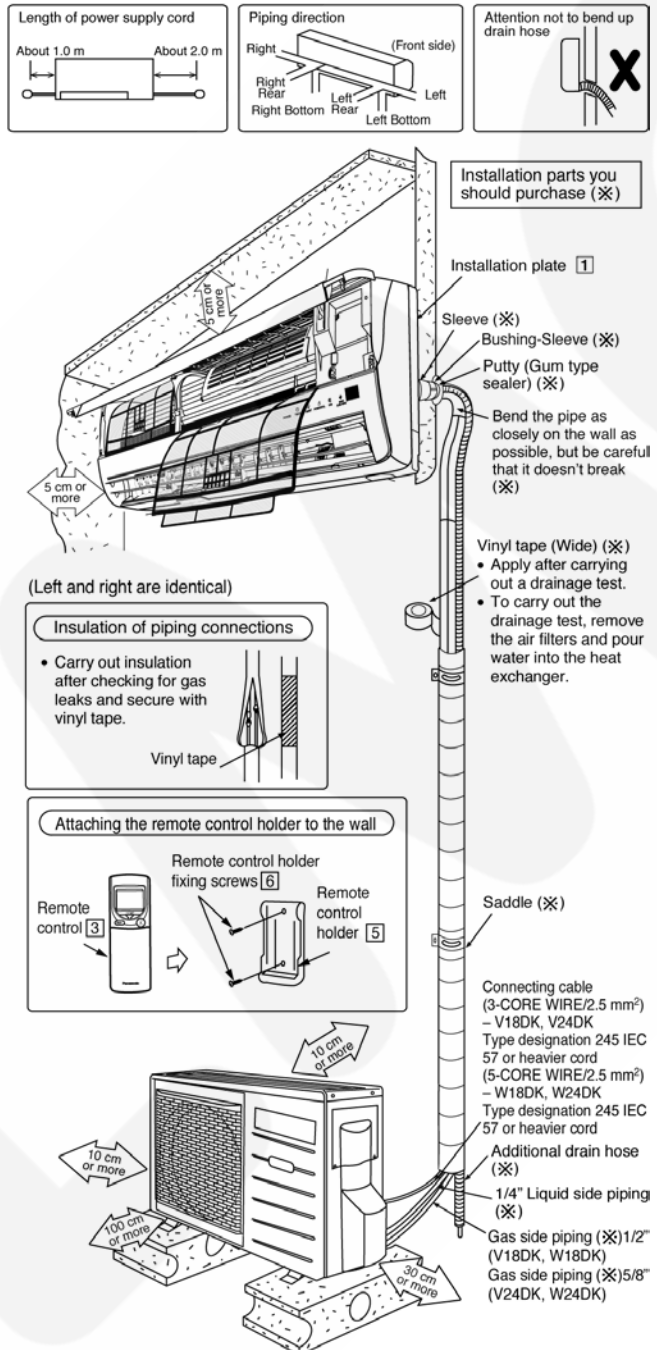

- This illustration is for explanation purposes only. The indoor unit will actually face a different way.

10.2. Indoor Unit

10.2.1. SELECT THE BEST LOCATION (Refer to “Select the best location” section)

10.2.2. HOW TO FIX INSTALLATION PLATE

The mounting wall is strong and solid enough to prevent it from the vibration.

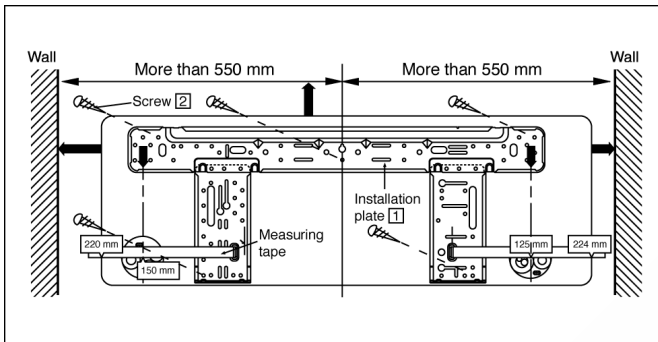

The centre of installation plate should be at more than 550 mm at right and left of the wall.

The distance from installation plate edge to ceiling should more than 67 mm.

From installation plate left edge to unit's left side is 47 mm.

From installation plate right edge to unit's right is 73 mm.

- Ⓑ : For left side piping, piping connection for liquid should be about 126 mm from this line.
: For left side piping, piping connection for gas should be about 174 mm from this line.
: For left side piping, piping connecting cable should be about 984 mm from this line.

1. Mount the installation plate on the wall with 5 screws or more.

(If mounting the unit on the concrete wall consider using anchor bolts.)

- Always mount the installation plate horizontally by aligning the marking-off line with the thread and using a level gauge.

2. Drill the piping plate hole with $\phi 70$ mm hole-core drill.

- Line according to the arrows marked on the lower left and right side of the installation plate. The meeting point of the extended line is the centre of the hole. Another method is by putting measuring tape at position as shown in the diagram above. The hole centre is obtained by measuring the distance namely 150 mm and 125 mm for left and right hole respectively.
- Drill the piping hole at either the right or the left and the hole should be slightly slanted to the outdoor side.

10.2.3. TO DRILL A HOLE IN THE WALL AND INSTALL A SLEEVE OF PIPING

1. Insert the piping sleeve to the hole.
2. Fix the bushing to the sleeve.
3. Cut the sleeve until it extrudes about 15 mm from the wall.

Caution

When the wall is hollow, please be sure to use the sleeve for tube ass'y to prevent dangers caused by mice biting the connecting cable.

4. Finish by sealing the sleeve with putty or caulking compound at the final stage.

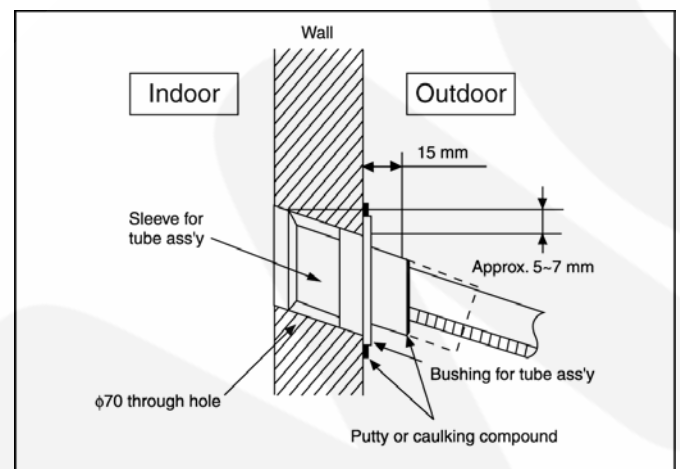

10.2.4. INDOOR UNIT INSTALLATION

1. For the right rear piping

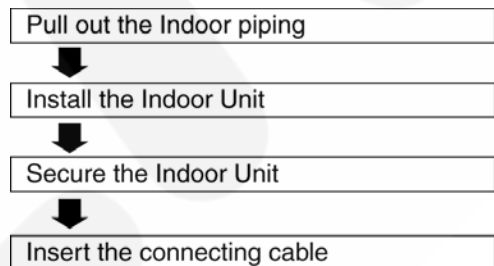

2. For the right and right bottom piping

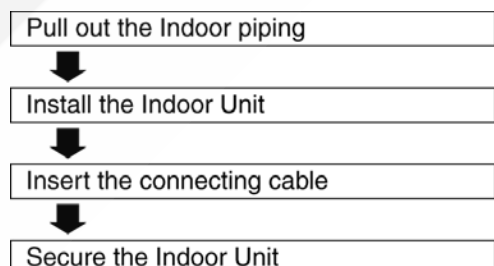

3. For the embedded piping

- Replace the drain hose
- Bend the embedded piping
 - Use a spring bender or equivalent to bend the piping so that the piping is not crushed.
- Install the Indoor Unit
- Cut and flare the embedded piping
 - When determining the dimension of the piping, slide the unit all the way to the left on the installation plate. Refer to the section "Cutting and flaring the piping".
- Pull the connecting cable into Indoor Unit
 - The inside and outside connecting cable can be connected without removing the front grille.
- Connect the piping
 - Please refer to "Connecting the piping" column in outdoor unit section. (Below steps are done after connecting the outdoor piping and gas-leakage confirmation.)
- Insulate and finish the piping
 - Please refer to "Piping and finishing" column of outdoor section and "Insulation of piping connections" column as mentioned in Indoor/Outdoor Unit Installation.
- Secure the Indoor Unit

Install the Indoor Unit

Hook the indoor unit onto the upper portion of installation plate (Engage the indoor unit with the upper edge of the installation plate). Ensure the hooks are properly seated on the installation plate by moving in left and right.

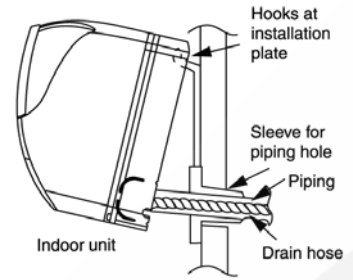

Secure the Indoor Unit

1. Tape the extra power supply cord in a bundle and keep it behind the chassis.
 - Ensure that the power supply cord is not clamped in between the unit's hook (2 positions) and installation plate.
2. Press the lower left and right side of the unit against the installation plate until hooks engages with their slots (sound click).

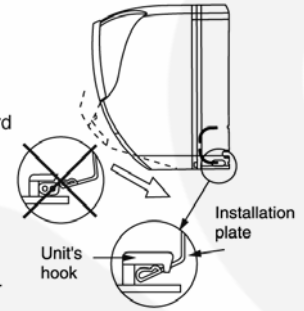

Pull out the piping and drain hose

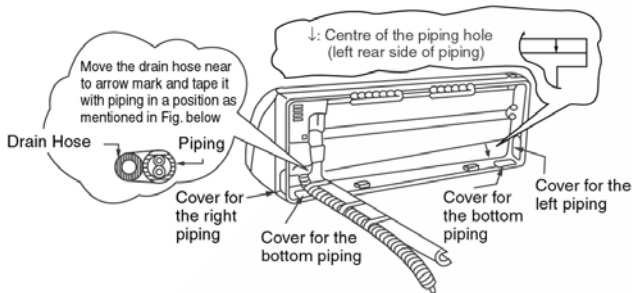

To take out the unit, push the **[PUSH]** marking at the bottom unit, and pull it slightly towards you to disengage the hooks from the unit.

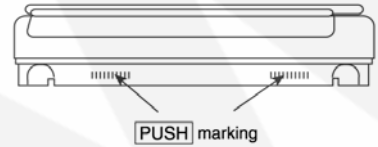

(This can be used for left rear piping & left bottom piping also.)

Exchange the drain hose and the cap

Refer view for left piping installation

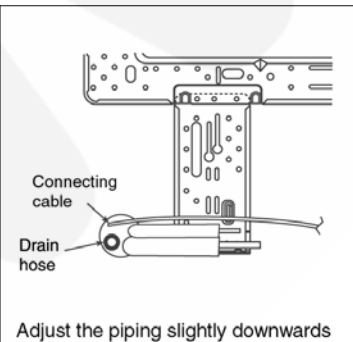
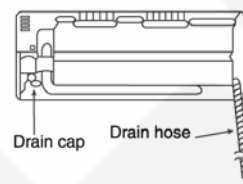

How to keep the cover

In case of the cover is cut, keep the cover at the rear of chassis as shown in the illustration for future reinstallation.

(Left, right and 2 bottom covers for piping)

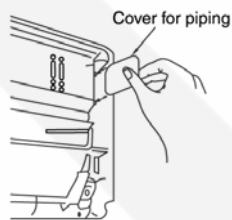

Insert the connecting cable

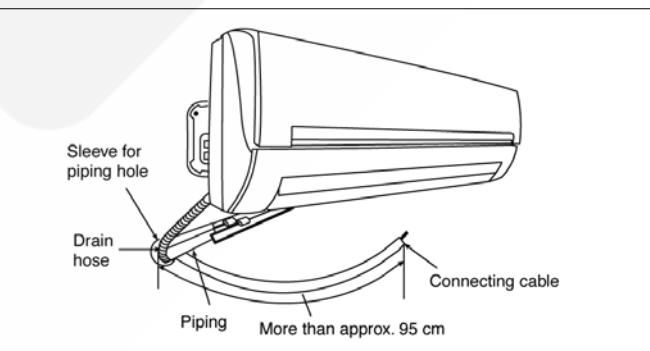
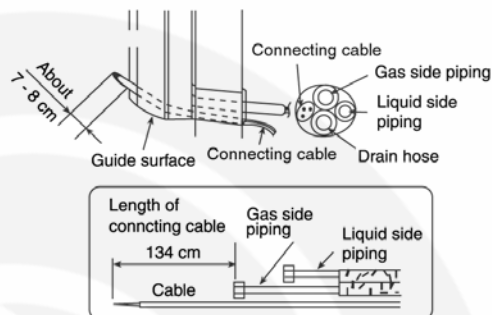

- How to pull the piping and drain hose out, in case of the embedded piping.

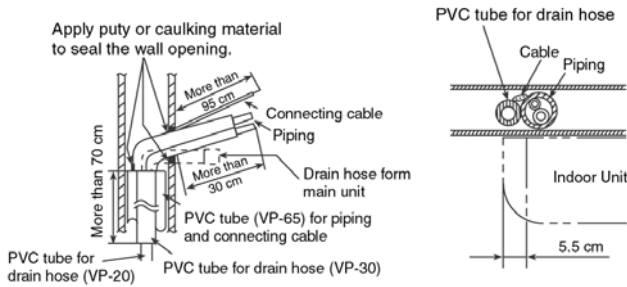

- In case of left piping how to insert the connecting cable and drain hose.

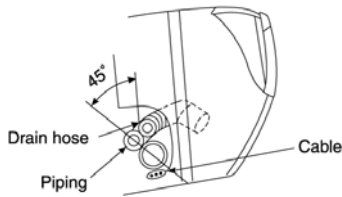

(For the right piping, follow the same procedure)

10.2.5. CONNECT THE CABLE TO THE INDOOR UNIT

1. The inside and outside connecting cable can be connected without removing the front grille.
2. Connecting cable between indoor unit and outdoor unit shall be approved polychloroprene sheathed $3 \times 2.5 \text{ mm}^2$ (V18DK, V24DK) or $5 \times 2.5 \text{ mm}^2$ (W18DK, W24DK) flexible cord, type designation 245 IEC 57 or heavier cord.
 - Ensure the color of wires of outdoor unit and the terminal Nos. are the same to the indoor's respectively.
 - Earth lead wire shall be longer than the other lead wires as shown in the figure for the electrical safety in case of the slipping out of the cord from the anchorage.

CS/CU-V18DK, V24DK

Terminals on the indoor unit	1	2	
Color of wires			
Terminals on the outdoor unit	1	2	

CS/CU-W18DK, W24DK

Terminals on the indoor unit	1	2	3	4	
Color of wires					
Terminals on the outdoor unit	1	2	3	4	

- Secure the cable onto the control board with the holder (clammer).

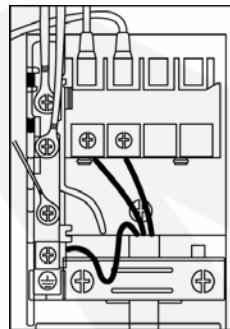

V18DK, V24DK

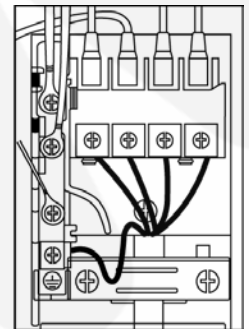

W18DK, W24DK

INSTALLATION OF SUPER ALLERU-BUSTER FILTER

1. Open the front panel.
2. Remove the air filter.
3. Remove Supersonic air purifying device.
4. Open the Supersonic air purifying device frame.
5. Insert the super alleru-buster filter and close the Supersonic air purifying device frame as show in illustration at right.

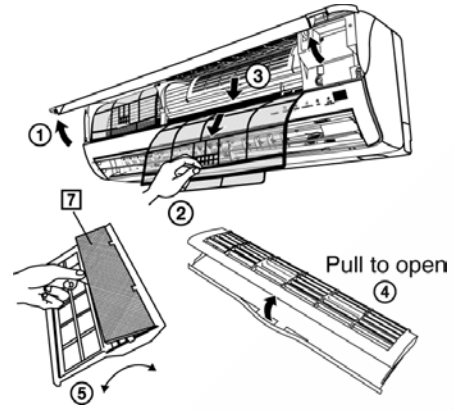

HOW TO TAKE OUT FRONT GRILLE

Please follow the steps below to take out front grille if necessary such as when servicing.

1. Open the intake grille.
2. Set the vertical airflow direction louvers to the horizontal position.
3. Slide down the 3 caps on the front grille as shown in the illustration below, and then remove the 3 mounting screws.
4. Pull the lower section of the front grille towards you to remove the front grille.

When reinstalling the front grille, first set the vertical airflow direction louver to the horizontal position and then carry out above steps 2 - 3 in the reverse order.

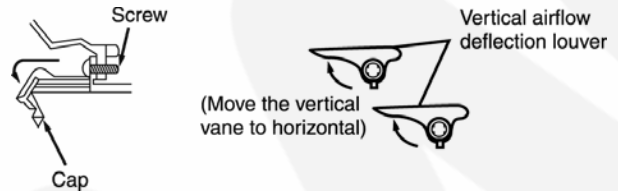

AUTO SWITCH OPERATION

The below operations will be performed by pressing the "AUTO" switch.

1. AUTO OPERATION MODE

The Auto operation will be activated immediately once the Auto Switch is pressed.

2. TEST RUN OPERATION (FOR PUMP DOWN/SERVICING PURPOSE)

The Test Run operation will be activated if the Auto Switch is pressed continuously for more than 5 sec. A "beep" sound will occur at the fifth sec., in order to identify the starting of Test Run operation

3. REMOTE CONTROLLER RECEIVING SOUND ON/OFF

The ON/OFF of remote controller receiving sound can be change over by pressing the following step:

a. Release the Auto Switch after Test Run operation is activated.

b. Then, within 20 sec., after a., press Auto Switch for more than 5 sec.

A "beep" "beep" sound will occur at the fifth sec., then release the Auto Switch.

c. Within 20 sec. after b., press Auto Switch again. Everytime Auto Switch is pressed (within 20 sec. interval), remote controller receiving sound status will be reversed between ON and OFF.

Long "beep" sound indicates that remote controller receiving sound is OFF.

Short "beep" sound indicates that remote controller receiving sound is ON.

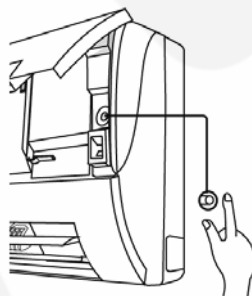

10.3. Outdoor Unit

10.3.1. SELECT THE BEST LOCATION

(Refer to “Select the best location” section)

10.3.2. INSTALL THE OUTDOOR UNIT

- After selecting the best location, start installation according to Indoor/Outdoor Unit Installation Diagram.

- Fix the unit on concrete or rigid frame firmly and horizontally by bolt nut. ($\phi 10$ mm).
- When installing at roof, please consider strong wind and earthquake. Please fasten the installation stand firmly with bolt or nails.

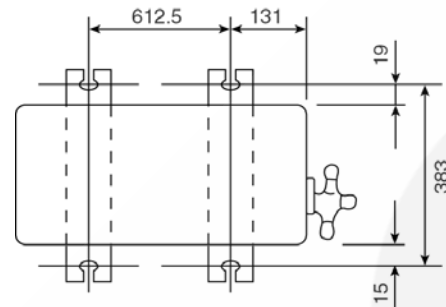

10.3.3. CONNECTING THE PIPING

Connecting The Piping To Indoor Unit

Please make flare after inserting flare nut (locate at joint portion of tube assembly) onto the copper pipe. (In case of using long piping)

Connect the piping

- Align the center of piping and sufficiently tighten the flare nut with fingers.
- Further tighten the flare nut with torque wrench in specified torque as stated in the table.

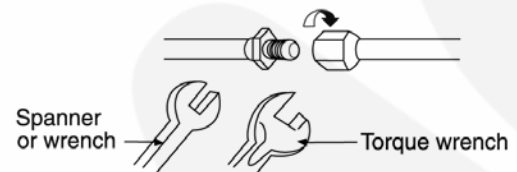

MODEL	Piping size (Torque)	
	Gas	Liquid
V18DK, W18DK	1/2" (55 N.m)	1/4" (18 N.m)
V24DK, W24DK,	5/8" (65 N.m)	1/4" (18 N.m)

Connecting The Piping To Outdoor Unit

Decide piping length and then cut by using pipe cutter. Remove burrs from cut edge. Make flare after inserting the flare nut (located at valve) onto the copper pipe.

Align center of piping to valves and then tighten with torque wrench to the specified torque as stated in the table.

CUTTING AND FLARING THE PIPING

- Please cut using pipe cutter and then remove the burrs.
- Remove the burrs by using reamer. If burrs is not removed, gas leakage may be caused.
Turn the piping end down to avoid the metal powder entering the pipe.
- Please make flare after inserting the flare nut onto the copper pipes.

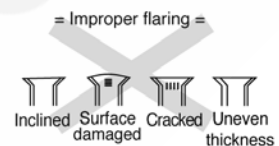
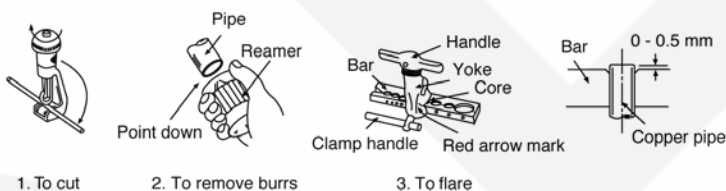

When properly flared, the internal surface of the flare will evenly shine and be of even thickness. Since the flare part comes into contact with the connections, carefully check the flare finish.

10.3.4. EVACUATION OF THE EQUIPMENT (FOR EUROPE & OCEANIA DESTINATION)

WHEN INSTALLING AN AIR CONDITIONER, BE SURE TO EVACUATE THE AIR INSIDE THE INDOOR UNIT AND PIPES in the following procedure.

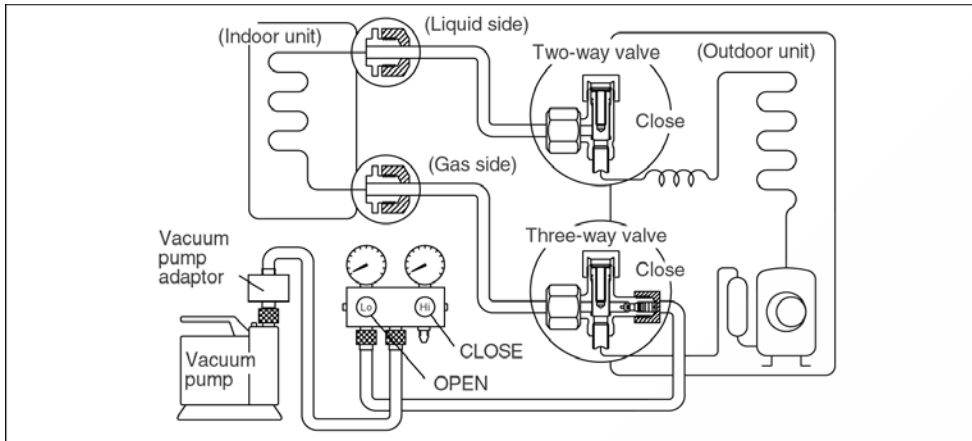

1. Connect a charging hose with a push pin to the Low and High side of a charging set and the service port of the 3-way valve.
 - Be sure to connect the end of the charging hose with the push pin to the service port.
2. Connect the center hose of the charging set to a vacuum pump with check valve, or vacuum pump and vacuum pump adaptor.
3. Turn on the power switch of the vacuum pump and make sure that the needle in the gauge moves from 0 cmHg (0 MPa) to -76 cmHg (-0.1 MPa). Then evacuate the air approximately ten minutes.
4. Close the Low side valve of the charging set and turn off the vacuum pump. Make sure that the needle in the gauge does not move after approximately five minutes.

Note: BE SURE TO FOLLOW THIS PROCEDURE IN ORDER TO AVOID REFRIGERANT GAS LEAKAGE.

5. Disconnect the charging hose from the vacuum pump and from the service port of the 3-way valve.
6. Tighten the service port caps of the 3-way valve at torque of 18 N.m with a torque wrench.
7. Remove the valve caps of both of the 2-way valve and 3-way valve. Position both of the valves to "OPEN" using a hexagonal wrench (4 mm).
8. Mount valve caps onto the 2-way valve and the 3-way valve.
 - Be sure to check for gas leakage.

CAUTION

- If gauge needle does not move from 0 cmHg (0 MPa) to -76 cmHg (-0.1 MPa), in step 3 above take the following measure:
- If the leak stops when the piping connections are tightened further, continue working from step 3.
- If the leak does not stop when the connections are retightened, repair the location of leak.
- Do not release refrigerant during piping work for installation and reinstallation. Take care of the liquid refrigerant, it may cause frostbite.

10.3.5. CONNECT THE CABLE TO THE OUTDOOR UNIT

1. Remove the control board cover from the unit by loosening the screw.
2. Connecting cable between indoor unit and outdoor unit shall be approved polychloroprene sheathed $3 \times 2.5 \text{ mm}^2$ (V18DK, V24DK) or $5 \times 2.5 \text{ mm}^2$ (W18DK, W24DK) flexible cord, type designation 245 IEC 57 or heavier cord.

CS/CU-V18DK, V24DK

Terminals on the indoor unit	1	2	⊕
Color of wires	Grey	Black	Blue
Terminals on the outdoor unit	1	2	⊕

CS/CU-W18DK, W24DK

Terminals on the indoor unit	1	2	3	4	⊕
Color of wires	Grey	Black	Red	Blue	Blue
Terminals on the outdoor unit	1	2	3	4	⊕

3. Secure the cable onto the control board with the holder (clammer).
4. Attach the control board cover back to the original position with the screw.

10.3.6. PIPE INSULATION

1. Please carry out insulation at pipe connection portion as mentioned in Indoor/Outdoor Unit Installation Diagram. Please wrap the insulated piping end to prevent water from going inside the piping.
2. If drain hose or connecting piping is in the room (where dew may form), please increase the insulation by using POLY-E FOAM with thickness 6 mm or above.

DISPOSAL OF OUTDOOR UNIT DRAIN WATER

- If a drain elbow is used, the unit should be placed on a stand which is taller than 3 cm.
- If the unit is used in an area where temperature falls below 0°C for 2 or 3 days in succession, it is recommended not to use a drain elbow, for the drain water freezes and the fan will not rotate.

CHECK THE DRAINAGE

- Open front panel and remove air filters.
(Drainage checking can be carried out without removing the front grille.)
- Pour a glass of water into the drain tray-styrofoam.
- Ensure that water flows out from drain hose of the indoor unit.

EVALUATION OF THE PERFORMANCE

- Operate the unit at cooling operation mode for fifteen minutes or more.
- Measure the temperature of the intake and discharge air.
- Ensure the difference between the intake temperature and the discharge is more than 8°C.

NOTE

These equipment shall be connected to a suitable main network with a main impedance less than the following:

CS/CU-V24DKE: 0.13Ω CS/CU-V24DKE: 0.06Ω

CU-W18DK, W24DK

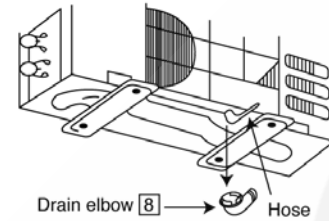

Install the hose at an angle so that the water smoothly flows out.

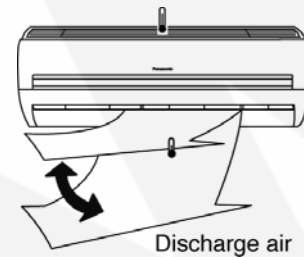
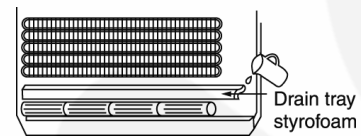

CHECK ITEMS

- | | |
|--|--|
| <input type="checkbox"/> Is there any gas leakage at flare nut connections? | <input type="checkbox"/> Is the indoor unit properly hooked to the installation plate? |
| <input type="checkbox"/> Has the heat insulation been carried out at flare nut connection? | <input type="checkbox"/> Is the power supply voltage complied with rated value? |
| <input type="checkbox"/> Is the connecting cable being fixed to terminal board firmly? | <input type="checkbox"/> Is there any abnormal sound? |
| <input type="checkbox"/> Is the connecting cable being clamped firmly? | <input type="checkbox"/> Is the cooling operation normal? |
| <input type="checkbox"/> Is the drainage OK?
(Refer to "Check the drainage" section) | <input type="checkbox"/> Is the thermostat operation normal? |
| <input type="checkbox"/> Is the earth wire connection properly done? | <input type="checkbox"/> Is the remote control's LCD operation normal? |
| | <input type="checkbox"/> Is the super alleru-buster filter is installed? |

11 Installation And Servicing Air Conditioner Using R410A

11.1. Outline

11.1.1. About R410A Refrigerant

1. Converting air conditioners to R410A

Since it was declared in 1974 that chlorofluorocarbons (CFC), hydro chlorofluorocarbons (HCFC) and other substances pose a destructive danger to the ozone layer in the earth's upper stratosphere (20 to 40 km above the earth), measures have been taken around the world to prevent this destruction.

The R22 refrigerant which has conventionally been used in ACs is an HCFC refrigerant and, therefore, possesses this ozone-destroying potential. International regulations (the Montreal Protocol on Ozone-Damaging Substances) and the domestic laws of various countries call for the early substitution of R22 by a refrigerant which will not harm the ozone layer.

- In ACs, the HFC refrigerant which has become the mainstream alternative is called R410A. Compared with R22, the pressure of R410A is approximately 1.6 times as high at the same refrigerant temperature, but the energy efficiency is about the same. Consisting of hydrogen (H), fluorine (F) and carbon (C), R410A is an HFC refrigerant. Another typical HFC refrigerant is R407C. While the energy efficiency of R407C is somewhat inferior to that of R410A, it offers the advantage of having pressure characteristics which are about the same as those of R22, and is used mainly in packaged ACs.

2. The characteristics of HFC (R410A) refrigerants

a. Chemical characteristics

The chemical characteristics of R410A are similar to those of R22 in that both are chemically stable, non-flammable refrigerants with low toxicity.

However, just like R22, the specific gravity of R410A gas is heavier than that of air. Because of this, it can cause an oxygen deficiency if it leaks into a closed room since it collects in the lower area of the room. It also generates toxic gas when it is directly exposed to a flame, so it must be used in a well ventilated environment where it will not collect.

Table 1 Physical comparison of R410A and R22

	R410A	R22
Composition (wt%)	R32/R125 (50/50)	R22 (100)
Boiling point (°C)	-51.4	-40.8
Vaporizing pressure (25°C)	1.56 Mpa (15.9 kgf/cm ²)	0.94 Mpa (9.6 kgf/cm ²)
Saturated vapor density	64.0 kg/m ³	44.4 kg/m ³
Flammability	Non-flammable	Non-flammable
Ozone-destroying point (ODP)	0	0.055
Global-warming point (GWP)	1730	1700

b. Compositional change (pseudo-azeotropic characteristics)

R410A is a pseudo-azeotropic mixture comprising the two components R32 and R125. Multi-component refrigerants with these chemical characteristics exhibit little compositional change even from phase changes due to vaporization (or condensation), which means that there is little change in the circulating refrigerant composition even when the refrigerant leaks from the gaseous section of the piping.

Accordingly, R410A can be handled in almost the same manner as the single-component refrigerant R22. However, when charging, because there is a slight change in composition between the gas phase and the liquid phase inside a cylinder or other container, charging should basically begin with the liquid side.

c. Pressure characteristics

As seen in Table 2, the gas pressure of R410A is approximately 1.6 times as high as that of R22 at the same refrigerant temperature, which means that special R410A tools and materials with high-pressure specifications must be used for all refrigerant piping work and servicing.

Table 2 Comparison of R410A and R22 saturated vapor density

Refrigerant Temperature (°C)	Unit: MPa	
	R410A	R22
-20	0.30	0.14
0	0.70	0.40
20	1.35	0.81
40	2.32	1.43
60	3.73	2.33
65	4.15	2.60

d. R410A refrigerating machine oil

Conventionally, mineral oil or a synthetic oil such as alkylbenzene has been used for R22 refrigerating machine oil. Because of the poor compatibility between R410A and conventional oils like mineral oil, however, there is a tendency for the refrigerating machine oil to collect in the refrigerating cycle. For this reason, polyester and other synthetic oils which have a high compatibility with R410A are used as refrigerating machine oil.

Because of the high hygroscopic property of synthetic oil, more care must be taken in its handling than was necessary with conventional refrigerating machine oils. Also, these synthetic oils will degrade if mixed with mineral oil or alkylbenzene, causing clogging in capillary tubes or compressor malfunction. Do not mix them under any circumstances.

11.1.2. Safety Measures When Installing/Serviceing Refrigerant Piping

Cause the gas pressure of R410A is approximately 1.6 times as high as that of R22, a mistake in installation or servicing could result in a major accident. It is essential that you use R410A tools and materials, and that you observe the following precautions to ensure safety.

1. Do not use any refrigerant other than R410A in ACs that have been used with R410A.
2. If any refrigerant gas leaks while you are working, ventilate the room. Toxic gas may be generated if refrigerant gas is exposed to a direct flame.
3. When installing or transferring an AC, do not allow any air or substance other than R410A to mix into the refrigeration cycle. If it does, the pressure in the refrigeration cycle can become abnormally high, possibly causing an explosion and/or injury.
4. After finishing the installation, check to make sure there is no refrigerant gas leaking.
5. When installing or transferring an AC, follow the instructions in the installation instructions carefully. Incorrect installation can result in an abnormal refrigeration cycle or water leakage, electric shock, fire, etc.
6. Do not perform any alterations on the AC unit under any circumstances. Have all repair work done by a specialist. Incorrect repairs can result in a water leakage, electric shock, fire, etc.

11.2. Tools For Installing/Serviceing Refrigerant Piping

11.2.1. Necessary Tools

In order to prevent an R410A AC from mistakenly being charged with any other refrigerant, the diameter of the 3-way valve service port on the outdoor unit has been changed. Also, to increase its ability to withstand pressure, the opposing dimensions have been changed for the refrigerant pipe flaring size and flare nut. Accordingly, when installing or servicing refrigerant piping, you must have both the R410A and ordinary tools listed below.

Table 3 Tools for installation, transferring or replacement

Type of work	Ordinary tools	R410A tools
Flaring	Flaring tool (clutch type), pipe cutter, reamer	Copper pipe gauge for clearance Adjustment, flaring tool (clutch type)*1)
Bending, connecting pipes	Torque wrench (nominal diameter 1/4, 3/8, 1/2). Fixed spanner (opposing sides 12 mm, 17 mm, 19 mm). Adjustable wrench, Spring bender	
Air purging	Vacuum pump. Hexagonal wrench (opposing sides 4 mm)	Manifold gauge, charging hose, vacuum pump adaptor
Gas leak inspection	Gas leak inspection fluid or soapy water	Electric gas leak detector for HFC refrigerant*2)

*1) You can use the conventional (R22) flaring tool. If you need to buy a new tool, buy the R410A type.

*2) Use when it is necessary to detect small gas leaks.

For other installation work, you should have the usual tools, such as screwdrivers (+,-), a metal-cutting saw, an electrical drill, a hole core drill (65 or 70 dia.), a tape measure, a level, a thermometer, a clamp meter, an insulation tester, a voltmeter, etc.

Table 4 Tools for serving

Type of work	Ordinary tools	R410A tools
Refrigerant charging		Electronic scale for refrigerant charging. Refrigerant cylinder. Charging orifice and packing for refrigerant cylinder
Brazing (Replacing refrigerating cycle part*1)	Nitrogen blow set (be sure to use nitrogen blowing for all brazing), and brazing machine	

*1) Always replace the dryer of the outdoor unit at the same time. The replacement dryer is wrapped in a vacuum pack. Replace it last among the refrigerating cycle parts. Start brazing as soon as you have opened the vacuum pack, and begin the vacuuming operation within 2 hours.

11.2.2. R410A Tools

1. Copper tube gauge for clearance adjustment
(used when flaring with the conventional flaring tool (clutch type))

- This gauge makes it easy to set the clearance for the copper tube to 1.0-1.5 mm from the clamp bar of the flaring tool.

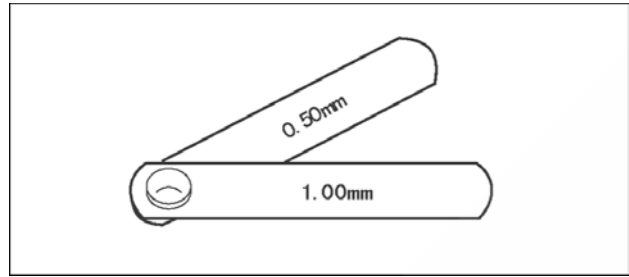

Fig. 1 Copper tube gauge for clearance adjustment

2. Flaring tool (clutch type)

- In the R410A flaring tool, the receiving hole for the clamp bar is enlarged so the clearance from the clamp bar can be set to 0-0.5 mm, and the spring inside the tool is strengthened to increase the strength of the pipe-expanding torque. This flaring tools can also be used with R22 piping, so we recommend that you select it if you are buying a new flaring tool.

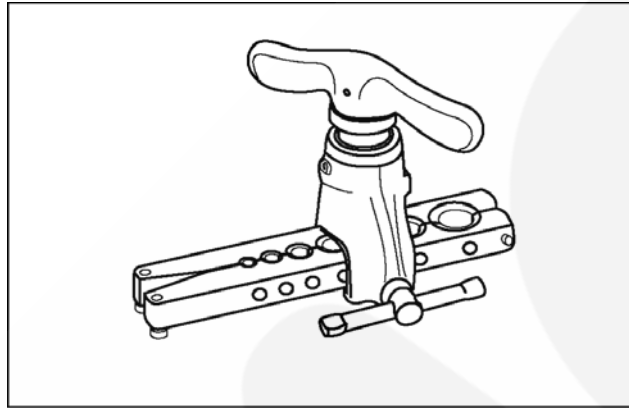

Fig. 2 Flaring tool (clutch type)

3. Torque wrenches

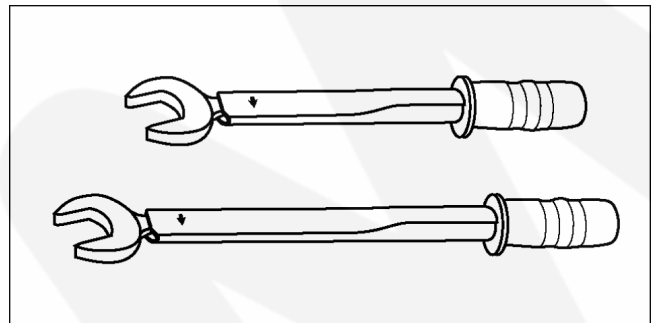

Fig. 3 Torque wrenches

Table 5

	Conventional wrenches	R410A wrenches
For 1/4 (opposite side x torque)	17 mm x 18 N.m (180 kgf.cm)	17 mm x 18 N.m (180 kgf.cm)
For 3/8 (opposite side x torque)	22 mm x 42 N.m (420 kgf.cm)	22 mm x 42 N.m (420 kgf.cm)
For 1/2 (opposite side x torque)	24 mm x 55 N.m (550 kgf.cm)	26 mm x 55 N.m (550 kgf.cm)

4. Manifold gauge

- Because the pressure is higher for the R410A type, the conventional type cannot be used.

Table 6 Difference between R410A and conventional high / low-pressure gauges

	Conventional gauges	R410A gauges
High-pressure gauge (red)	-76 cmHg - 35 kgf/cm ³	-0.1 - 5.3 Mpa -76 cmHg - 53 kgf/cm ³
Low-pressure gauge (blue)	-76 cmHg - 17 kgf/cm ³	-0.1 - 3.8 Mpa -76 cmHg - 38 kgf/cm ³

- The shape of the manifold ports has been changed to prevent the possibility of mistakenly charging with another type of refrigerant.

Table 7 Difference between R410A and conventional manifold port size

	Conventional gauges	R410A gauges
Port size	7/16 UNF 20 threads	1/2 UNF 20 threads

5. Charging hose

- The pressure resistance of the charging hose has been raised to match the higher pressure of R410A. The hose material has also been changed to suit HFC use, and the size of the fitting has been changed to match the manifold ports.

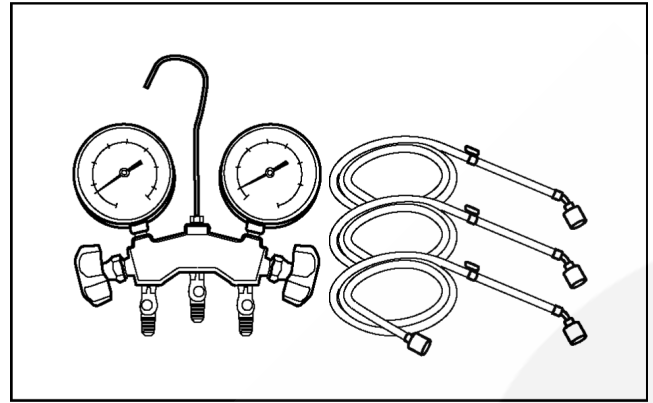

Fig. 4 Manifold gauge charging hose

Table 8 Difference between R410A and conventional charging hoses

		Conventional hoses	R410A hoses
Pressure resistance	Working pressure	3.4 MPa (35 kgf/cm ³)	5.1 MPa (52 kgf/cm ³)
	Bursting pressure	17.2 MPa (175 kgf/cm ³)	27.4 MPa (280 kgf/cm ³)
Material		NBR rubber	HNBR rubber Nylon coating inside

6. Vacuum pump adaptor

- When using a vacuum pump for R410A, it is necessary to install an electromagnetic valve to prevent the vacuum pump oil from flowing back into the charging hose. The vacuum pump adaptor is installed for that purpose. If the vacuum pump oil (mineral oil) becomes mixed with R410A, it will damage the unit.

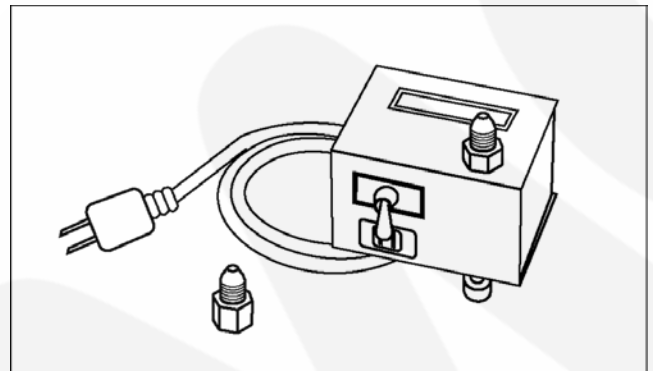

Fig. 5 Vacuum pump adaptor

7. Electric gas leak detector for HFC refrigerant

- The leak detector and halide torch that were used with CFC and HCFC cannot be used with R410A (because there is no chlorine in the refrigerant).
- The present R134a leak detector can be used, but the detection sensitivity will be lower (setting the sensitivity for R134a at 1, the level for R410A will drop to 0.6).
- For detecting small amounts of gas leakage, use the electric gas leak detector for HFC refrigerant. (Detection sensitivity with R410A is about 23 g/year).

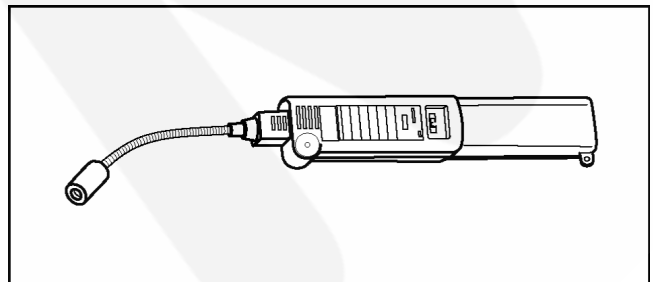

Fig. 6 Electric gas leak detector for HFC refrigerant

8. Electronic scale for refrigerant charging

- Because of the high pressure and fast vaporizing speed of R410A, the refrigerant cannot be held in a liquid phase inside the charging cylinder when charging is done using the charging cylinder method, causing bubbles to form in the measurement scale glass and making it difficult to see the reading. (Naturally, the conventional R22 charging cylinder cannot be used because of the differences in the pressure resistance, scale gradation, connecting port size, etc.)
- The electronic scale has been strengthened by using a structure in which the weight detector for the refrigerant cylinder is held by four supports. It is also equipped with two connection ports, one for R22 (7/16 UNF, 20 threads) and one for R410A (1/2 UNF, 20 threads), so it can also be used for conventional refrigerant charging.
- There are two types of electronic scales, one for 10-kg cylinders and one for 20-kg cylinders. (The 10-kg cylinder is recommended.)

Refrigerant charging is done manually by opening and closing the valve.

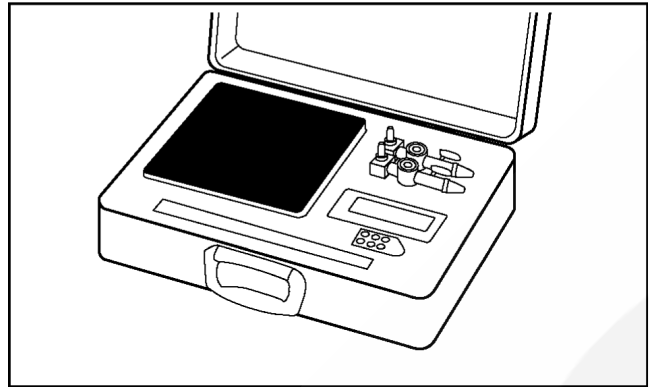

Fig. 7 Electronic scale for refrigerant charging

9. Refrigerant cylinders

- The R410A cylinders are labeled with the refrigerant name, and the coating color of the cylinder protector is pink, which is the color stipulated by ARI of the U.S.
- Cylinders equipped with a siphon tube are available to allow the cylinder to stand upright for liquid refrigerant charging.



Fig. 8 Refrigerant cylinders

10. Charging orifice and packing for refrigerant cylinders

- The charging orifice must match the size of the charging hose fitting (1/2 UNF, 20 threads).
- The packing must also be made of an HFC-resistant material.

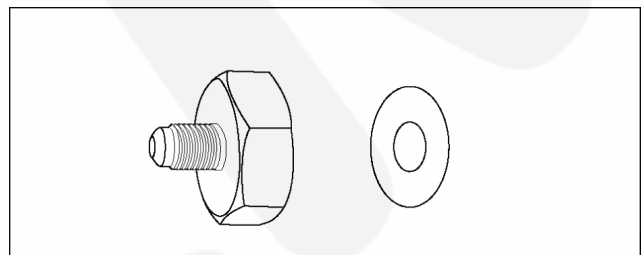

Fig. 9 Charging orifice and packing

11.2.3. R410A Tools Which Are Usable for R22 Models

Table 9 R410A tools which are usable for R22 models

	R410A tools	Usable for R22 models
(1)	Copper tube gauge for clearance adjustment	OK
(2)	Flaring tool (clutch type)	OK
(3)	Manifold gauge	NG
(4)	Charging hose	NG
(5)	Vacuum pump adaptor	OK
(6)	Electric gas leak detector for HFC refrigerant	NG
(7)	Electronic scale for refrigerant charging	OK
(8)	Refrigerant cylinder	NG
(9)	Charging orifice and packing for refrigerant cylinder	NG

11.3. Refrigerant Piping Work

11.3.1. Piping Materials

It is recommended that you use copper and copper alloy jointless pipes with a maximum oil adherence of 40 mg/10m. Do not use pipes that are crushed, deformed, or discolored (especially the inside surface). If these inferior pipes are used, impurities may clog the expansion valves or capillaries.

Because the pressure of ACs using R410A is higher than those using R22, it is essential that you select materials that are appropriate for these standards.

The thickness of the copper tubing used for R410A is shown in Table 10. Please be aware that tubing with a thickness of only 0.7 mm is also available on the market, but this should never be used.

Table 10 Copper tube thickness (mm)

Soft pipe		Thickness (mm)	
Nominal diameter	Outside diameter (mm)	R410A	(Reference) R22
1/4	6.35	0.80	0.80
3/8	9.52	0.80	0.80
1/2	12.7	0.80	0.80

11.3.2. Processing and Connecting Piping Materials

When working with refrigerant piping, the following points must be carefully observed: no moisture or dust must be allowed to enter the piping, and there must be no refrigerant leaks.

1. Procedure and precautions for flaring work

a. Cut the pipe

Use a pipe cutter, and cut slowly so the pipe will not be deformed.

b. Remove burrs and clean shavings from the cut surface

If the shape of the pipe end is poor after removing burrs, or if shavings adhere to the flared area, it may lead to refrigerant leaks.

To prevent this, turn the cut surface downward and remove burrs, then clean the surface, carefully.

c. Insert the flare nut (be sure to use the same nut that is used on the AC unit)

d. Flaring

Check the clamp bar and the cleanliness of the copper pipe.

Be sure to use the clamp bar to do the flaring with accuracy. Use either an R410A flaring tool, or a conventional flaring tool. Flaring tools come in different sizes, so be sure to check the size before using. When using a conventional flaring tool, use the copper pipe gauge for clearance adjustment, etc., to ensure the correct A dimension (see Fig. 10)

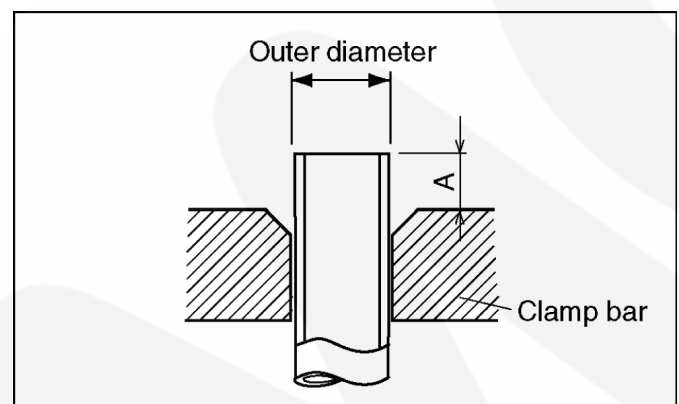

Fig. 10 Flaring dimensions

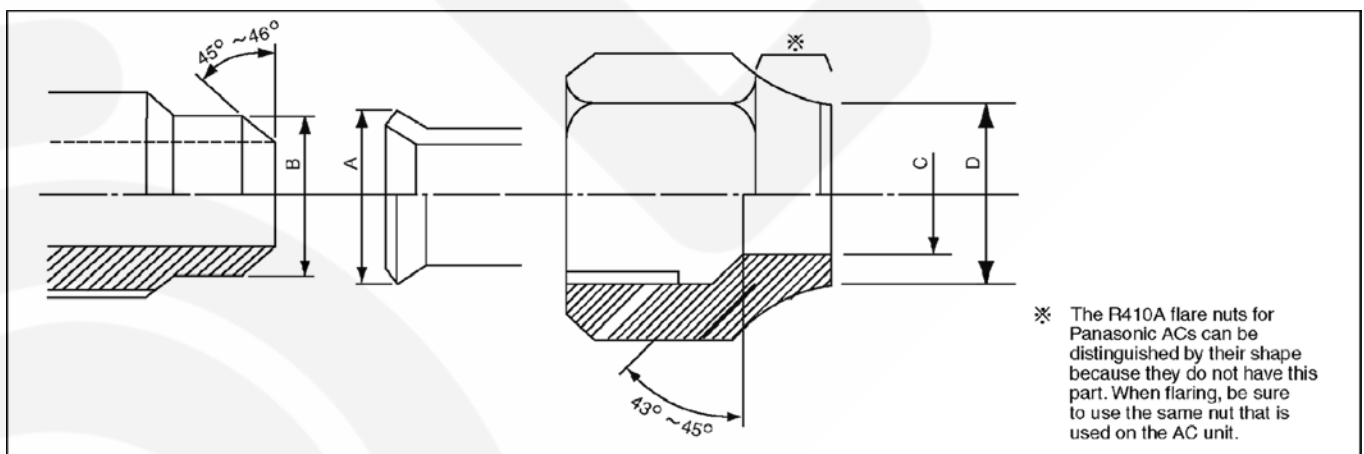

Fig. 11 Relation between the flare nut structure and flaring tool end

Table 11 R410A flaring dimensions

Nominal diameter	Outside diameter (mm)	Wall thickness (mm)	A (mm)		
			R410A flaring tool, clutch type	Conventional flaring tool	
				Clutch type	Wing-nut type
1/4	6.35	0.8	0 - 0.5	1.0 - 1.5	1.5 - 2.0
3/8	9.52	0.8	0 - 0.5	1.0 - 1.5	1.5 - 2.0
1/2	12.70	0.8	0 - 0.5	1.0 - 1.5	2.0 - 2.5

Table 12 R22 flaring dimensions

Nominal diameter	Outside diameter (mm)	Wall thickness (mm)	A (mm)		
			R410A flaring tool, clutch type	Conventional flaring tool	
				Clutch type	Wing-nut type
1/4	6.35	0.8	0 - 0.5	0.5 - 1.0	1.0 - 1.5
3/8	9.52	0.8	0 - 0.5	0.5 - 1.0	1.0 - 1.5
1/2	12.70	0.8	0 - 0.5	0.5 - 1.0	1.5 - 2.0

Table 13 R410A flare and flare nut dimensions Unit: mm

Nominal diameter	Outside diameter (mm)	Wall thickness (mm)	A +0, -0.4	B dimension	C dimension	D dimension	Flare nut width
1/4	6.35	0.8	9.1	9.2	6.5	13	17
3/8	9.52	0.8	13.2	13.5	9.7	20	22
1/2	12.70	0.8	16.6	16.0	12.9	23	26

Table 14 R22 flare and flare nut dimensions Unit: mm

Nominal diameter	Outside diameter (mm)	Wall thickness (mm)	A +0, -0.4	B dimension	C dimension	D dimension	Flare nut width
1/4	6.35	0.8	9.0	9.2	6.5	13	17
3/8	9.52	0.8	13.0	13.5	9.7	20	22
1/2	12.70	0.8	16.2	16.0	12.9	20	24

2. Procedure and precautions for flare connection

- Check to make sure there is no scratches, dust, etc., on the flare and union.
- Align the flared surface with the axial center of the union.
- Use a torque wrench, and tighten to the specified torque. The tightening torque for R410A is the same as the conventional torque value for R22. Be careful, because if the torque is too weak, it may lead to a gas leak. If it is too strong, it may split the flare nut or make it impossible to remove the flare nut.

Table 15 R410A tightening torque

Nominal diameter	Outside diameter (mm)	Tightening torque N.m (kgf.cm)	Torque wrench tightening torque N.m (kgf.cm)
1/4	6.35	14 - 18 (140 - 180)	18 (180)
3/8	9.52	33 - 42 (330 - 420)	42 (420)
1/2	12.70	55 (550)	55 (550)

11.3.3. Storing and Managing Piping Materials

1. Types of piping and their storage

The following is a general classification of the refrigerant pipe materials used for ACs.

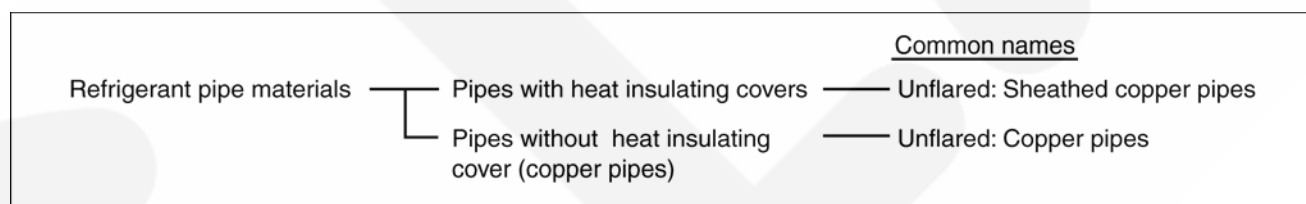

Because the gas pressure of R410A is approximately 1.6 times as high as that of R22, copper pipes with the thickness shown in Table 10, and with minimal impurities must be used. Care must also be taken during storage to ensure that pipes are not crushed, deformed, or scratched, and that no dust, moisture or other substance enters the pipe interior. When storing sheathed copper pipes or plain copper pipes, seal the openings by pinching or taping them securely.

2. Makings and management

a. Sheathed copper pipes and copper-element pipes

When using these pipes, check to make sure that they are the stipulated thickness. For flare nuts, be sure to use the same nut that is used on the AC unit.

b. Copper pipes

Use only copper pipes with the thickness given in table 10, and with minimal impurities. Because the surface of the pipe is exposed, you should take special care, and also take measures such as marking the pipes to make sure they are easily distinguished from other piping materials, to prevent mistaken use.

3. Precautions during refrigerant piping work

Take the following precautions on-site when connecting pipes. (Keep in mind that the need to control the entry of moisture and dust is even more important than in conventional piping).

- Keep the open ends of all pipes sealed until connection with AC equipment is complete.
- Take special care when doing piping work on rainy days. The entering of moisture will degrade the refrigerating machine oil, and lead to malfunctions in the equipment.
- Complete all pipe connections in as short a time as possible. If the pipe must be left standing for a long time after removing the seal, it must be thoroughly purged with nitrogen, or dried with a vacuum pump.

11.4. Installation, Transferring, Servicing

11.4.1. Inspecting Gas Leaks with a Vacuum Pump for New Installations (Using New Refrigerant Piping)

- From the viewpoint of protecting the global environment, please do not release refrigerant into the atmosphere.
 - Connect the projecting side (pin-pushing side) of the charging hose for the manifold gauge to the service port of the 3-way valve. (1)
 - Fully open the handle Lo of the manifold gauge and run the vacuum pump. (2) (If the needle of the low-pressure gauge instantly reaches vacuum, re-check step a.)
 - Continue the vacuum process for at least 15 minutes, then check to make sure the low-pressure gauge has reached -0.1 MPa (-76 cmHg). Once the vacuum process has finished, fully close the handle Lo of the manifold gauge and stop the vacuum pump operation, then remove the charging hose that is connected to the vacuum pump adaptor. (Leave the unit in that condition for 1-2 minutes, and make sure that the needle of the manifold gauge does not return.) (2) and (3)
 - Turn the valve stem of the 2-way valve 90° counter-clockwise to open it, then, after 10 seconds, close it and inspect for a gas leak (4)
 - Remove the charging hose from the 3-way valve service port, then open both the 2-way valve and 3-way valve. (1) (4) (Turn the valve stem in the counter-clockwise direction until it gently makes contact. Do not turn it forcefully).
 - Tighten the service port cap with a torque wrench (18 N.m (1.8 kgf.m)). (5) Then tighten the 2-way valve and 3-way valve caps with a torque wrench (42 N.m (4.2 kgf.m)) or (55 N.m (5.5 kgf.m)). (6)
 - After attaching each of the caps, inspect for a gas leak around the cap area. (5) (6)

Precautions

- Be sure to read the instructions for the vacuum pump, vacuum pump adaptor and manifold gauge prior to use, and follow the instructions carefully.
- Make sure that the vacuum pump is filled with oil up to the designated line on the oil gauge.
- The gas pressure back flow prevention valve on the charging hose is generally open during use. When you are removing the charging hose from the service port, it will come off more easily if you close this valve.

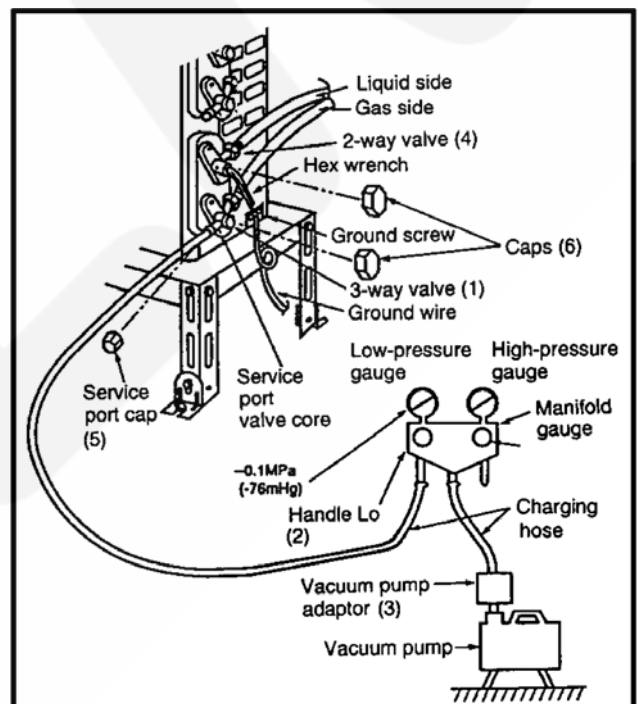

Fig. 12 Vacuum pump air purging configuration

11.4.2. Transferring (Using New Refrigerant Piping)

1. Removing the unit

a. Collecting the refrigerant into the outdoor unit by pumping down

The refrigerant can be collected into the outdoor unit (pumping down) by pressing the TEST RUN button, even when the temperature of the room is low.

- Check to make sure that the valve stems of the 2-way valve and 3-way valve have been opened by turning them counter-clockwise. (Remove the valve stem caps and check to see that the valve stems are fully opened position. Always use a hex wrench (with 4-mm opposing sides) to operate the valve stems.)
- Press the TEST RUN button on the indoor unit, and allow preliminary operation for 5-6 minutes. (TEST RUN mode)
- After stopping the operation, let the unit sit for about 3 minutes, then close the 2-way valve by turning the valve stem in the clockwise direction.
- Press the TEST RUN button on the indoor unit again, and after 2-3 minutes of operation, turn the valve stem of the 3-way valve quickly in the clockwise direction to close it, then stop the operation.
- Tighten the caps of the 2-way valve and 3-way valve to the stipulated torque.
- Remove the connection pipes (liquid side and gas side).

b. Removing the indoor and outdoor units.

- Disconnect the pipes and connecting electric cables from between the indoor and outdoor units.
- Put capped flare nuts onto all of the pipe connections of the indoor and outdoor units, to make sure no dust or other foreign matter enters.
- Remove the indoor and outdoor units.

2. Installing the unit

Install the unit using new refrigerant piping. Follow the instructions in section 4.1 to evacuate the pipes connecting the indoor and outdoor units, and the pipes of the indoor unit, and check for gas leaks.

11.4.3. AC Units Replacement (Using Existing Refrigerant Piping)

When replacing an R410A AC unit with another R410A AC unit, you should re-flare the refrigerant piping. Even though the replacement AC unit uses the R410A, problems occur when, for example, either the AC unit maker or the refrigerating machine oil is different.

When replacing an R22 AC unit with an R410A AC unit, the following checks and cleaning procedures are necessary but are difficult to do because of the chemical characteristics of the refrigerating machine oil (as described in items c) and d) of section **About R410A Refrigerant**). In this case, you should use new refrigerant piping rather than the existing piping.

1. Piping check

Because of the different pressure characteristics of R22 and R410A, the design pressure for the equipment is 1.6 times different. The wall thickness of the piping must comply with that shown in Table 10, but this is not easy to check. Also, even if the thickness is correct, there may be flattened or bent portions midway through the piping due to sharp curves. Buried sections of the piping also cannot be checked.

2. Pipe cleaning

A large quantity of refrigerating machine oil (mineral oil) adheres to existing pipes due to the refrigeration cycle circulation. If the pipes are used just as they are for the R410A cycle, the capacity will be lowered due to the incompatibility of this oil with the R410A, or irregularities may occur in the refrigeration cycle. For this reason, the piping must be thoroughly cleaned, but this is difficult with the present technology.

11.4.4. Refrigerant Compatibility (Using R410A Refrigerant in R22 ACs and Vice Versa)

Do not operate an existing R22 AC with the new R410A refrigerant. Doing so would result in improper functioning of the equipment or malfunction, and might lead to a major accident such as an explosion in the refrigeration cycle. Similarly, do not operate an R410A AC with R22 refrigerant. The chemical reaction between the refrigerating machine oil used in R410A ACs and the chlorine that is contained in R22 would cause the refrigerating machine oil to degrade and lead to malfunction.

11.4.5. Recharging Refrigerant During Servicing

When recharging is necessary, insert the specified amount of new refrigerant in accordance with the following procedure.

1. Connect the charging hose to the service port of the outdoor unit.
2. Connect the charging hose to the vacuum pump adaptor. At this time, fully open the 2-way valve and 3-way valve.
3. Fully open the handle Lo of the manifold gauge, turn on the power of the vacuum pump and continue the vacuum process for at least one hour.
4. Confirm that the low pressure gauge shows a reading of -0.1 Mpa (-76 cmHg), then fully close the handle Lo, and turn off the vacuum pump. Wait for 1-2 minutes, then check to make sure that the needle of the Low pressure gauge has not returned. See Fig. 13 for the remaining steps of this procedure.
5. Set the refrigerant cylinder onto the electronic scale, then connect the hose the cylinder and to the connection port for the electronic scale. (1)(2)

Precaution:

Be sure to set up the cylinder for liquid charging. If you use a cylinder equipped with a siphon tube, you can charge the liquid without having to turn the cylinder around

6. Remove the charging hose of the manifold gauge from the vacuum pump adaptor, and connect it to the connection port of the electronic scale. (2)(3)
7. Open the valve of the refrigerant cylinder, then open the charging valve slightly and close it. Next, press the check valve of the manifold gauge and purge the air. (2)(4) (Watch the liquid refrigerant closely at this point.)
8. After adjusting the electronic scale to zero, open the charging valve, then open the valve Lo of the manifold gauge and charge with the liquid refrigerant. (2)(5) (Be sure to read the operating instructions for the electronic scale.)
9. If you cannot charge the stipulated amount, operate the unit in the cooling mode while charging a little of the liquid at a time (about 150 g/time as a guideline). If the charging amount is insufficient from one operation, wait about one minute, then use the same procedure to do the liquid charging again.

Precaution:

Never use the gas side to allow a larger amount of liquid refrigerant to be charged while operating the unit.

10. Close the charging valve, and after charging the liquid refrigerant inside the charging hose, fully close the valve Lo of the manifold gauge, and stop the operation of the unit. (2)(5)
11. Quickly remove the charging hose from the service port. (6) If you stop midway through, the refrigerant that is in the cycle will be discharged.
12. After putting on the caps for the service port and operating valve, inspect around the caps for a gas leak. (6)(7)

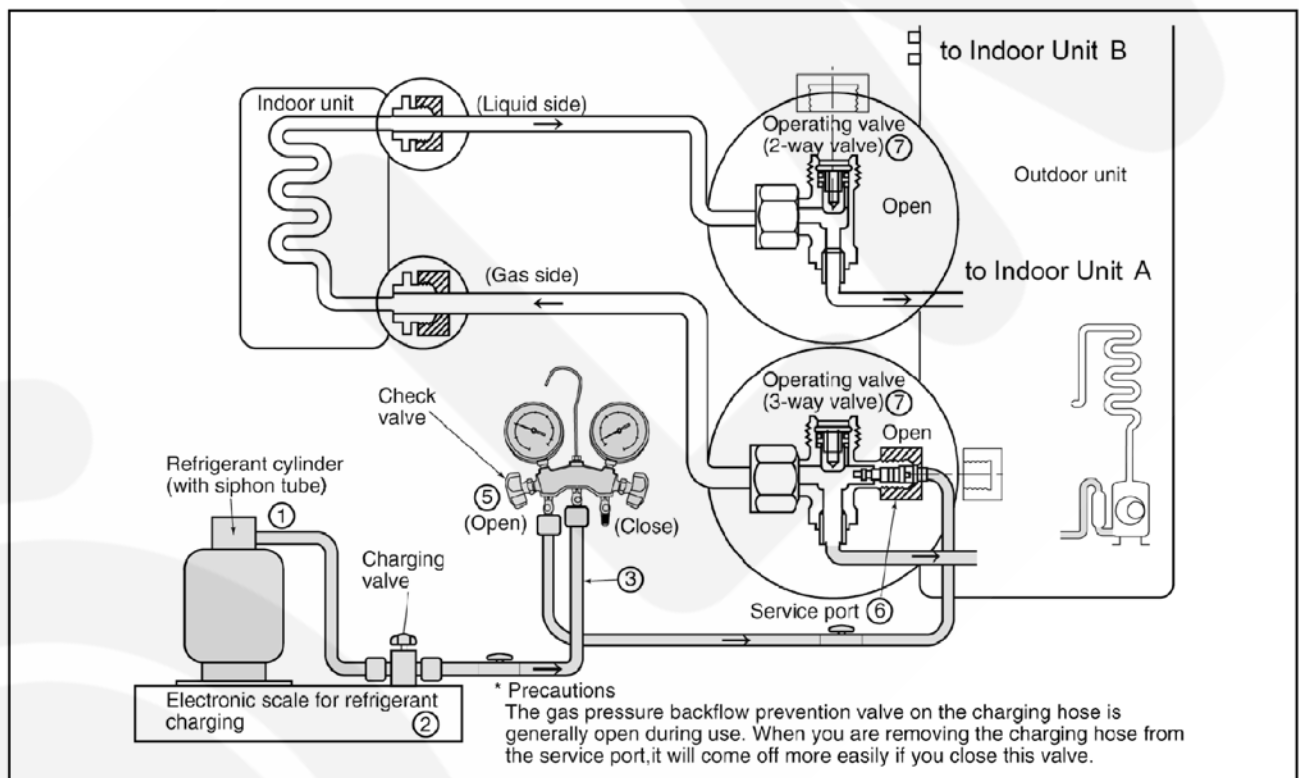

Fig. 13 Re-charging refrigerant

11.4.6. Brazing

As brazing requires sophisticated techniques and experiences, it must be performed by a qualified person.

In order to prevent the oxide film from occurring in the pipe interior during brazing, it is effective to proceed with brazing while letting dry nitrogen gas (N₂) flow.

<Brazing Method for Preventing Oxidation>

1. Attach a reducing valve to the nitrogen gas cylinder.
2. Apply a seal onto the clearance between the piping and inserted pipe for the nitrogen gas in order to prevent the nitrogen gas from flowing backward.
3. When the nitrogen gas is flowing, be sure to keep the piping end open.
4. Adjust the flow rate of nitrogen gas so that it is lower than 0.05 m³/h, or 0.02 MPa (0.2 kgf/cm²) by means of the reducing valve.
5. After taking the steps above, keep the nitrogen gas flowing until the piping cools down to a certain extent (i.e. temperature at which pipes are touchable with finger).
6. Completely remove the flux after brazing.

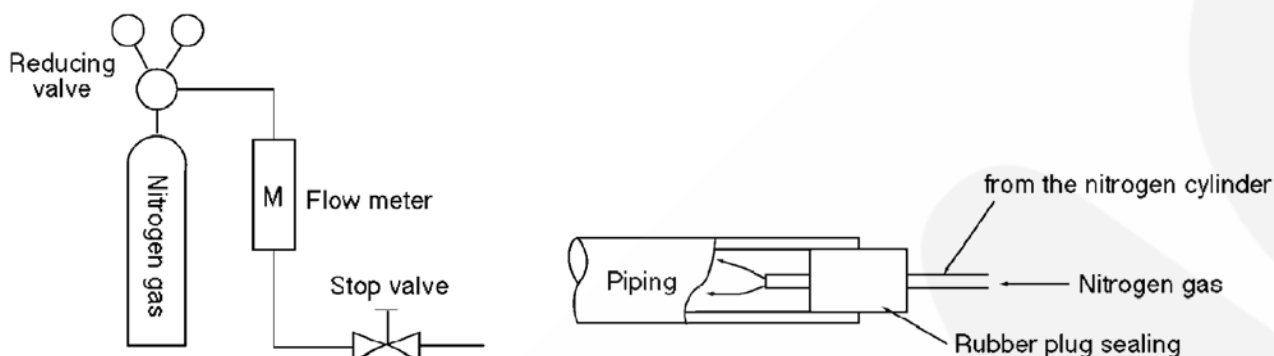

Fig. 14 Prevention of Oxidation during Brazing

Cautions during brazing

1. General Cautions

- a. The brazing strength should be high as required.
- b. After operation, airtightness should be kept under pressurized condition.
- c. During brazing do not allow component materials to become damaged due to overheating.
- d. The refrigerant pipe work should not become blocked with scale or flux.
- e. The brazed part should not restrict the flow in the refrigerant circuit.
- f. No corrosion should occur from the brazed part.

2. Prevention of Overheating

Due to heating, the interior and exterior surfaces of treated metal may oxidize. Especially, when the interior of the refrigerant circuit oxidizes due to overheating, scale occurs and stays in the circuit as dust, thus exerting a fatally adverse effect. So, make brazing at adequate brazing temperature and with minimum of heating area.

3. Overheating Protection

In order to prevent components near the brazed part from overheating damage or quality deterioration due to flame or heat, take adequate steps for protection such as (1) by shielding with a metal plate, (2) by using a wet cloth, and (3) by means of heat absorbent.

4. Movement during Brazing

Eliminate all vibration during brazing to protect brazed joints from cracking and breakage.

5. Oxidation Preventative

In order to improve the brazing efficiency, various types of antioxidant are available on the market. However, the constituents of these are widely varied, and some are anticipated to corrode the piping materials, or adversely affect HFC refrigerant, lubricating oil, etc. Exercise care when using an oxidation preventative.

11.4.7. Servicing Tips

The drier must also be replaced whenever replacing the refrigerant cycle parts. Replacing the refrigerant cycle parts first before replacing the drier. The drier is supplied in a vacuum pack. Perform brazing immediately after opening the vacuum pack, and then start the vacuum within two hours. In addition, the drier also needs to be replaced when the refrigerant has leaked completely. (Applicable for drier models only)

12 Servicing Information

12.1. Distinction Of Lead Free (PbF) Printed Circuit Board

- Printed circuit boards (manufactured) using lead free solder will have a PbF stamp on the Printed Circuit board.

CAUTION

- Pb free solder has a higher melting point than standard solder; typically the melting point is 50 - 70°F (30 - 40°C) higher. Please use a high temperature solder iron and set it to 700 ± 20°F (370 ± 10°C).
- Pb free solder will tend to splash when heated too high (about 1100°F/600°C).
- If you must use Pb solder, please completely remove all of the Pb free solder on the pin or solder area before applying Pb solder. If this is not practical, be sure to heat the Pb free solder until it melts, before applying Pb solder.

12.2. Indoor Electronic Controllers Removal Procedures

1. The Electronic Controller, a Signal Receiver and an Indicator (Fig. 3) can be seen by the below steps:

- Remove the 3 caps and 3 screws at the bottom of the Front Grille. (Fig. 1)
- Remove the Front Grille by releasing the 3 hooks at the top of the Front Grille. (Fig. 1)

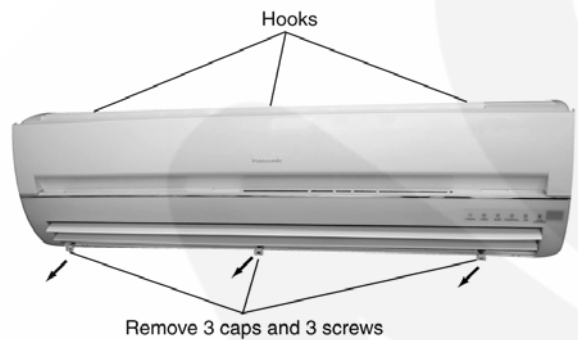

Fig. 1

- Unhook the tabs at the Control Board to remove the Control Board Cover. (Fig. 2)

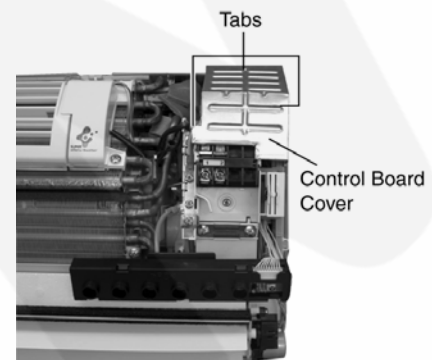

Fig. 2

2. To remove the Electronic Controllers:

- Release the 2 Particular Piece. (Fig. 3)
- Release the earth wire screw. (Fig. 3)
- Release the screw holder terminal board. (Fig. 3)
- Release the CN-DISP connector. (Fig. 3)
- Release the CN-TH connector. (Fig. 4)
- Release the CN-ION connector. (Fig. 4)
- Release the CN-SONIC connector. (Fig. 4)
- Release the CN-STM1 connector. (Fig. 4)
- Release the CN-STM2 connector. (Fig. 4)
- Release the hooks that hold the Electronic Controller and pull out the Electronic Controller. (Fig. 4)
- Release the CN-FM connector. (Fig. 4)
- Release the AC01 (white) connector. (Fig. 4)
- Release the two RY-PWR connector. (Fig. 4)

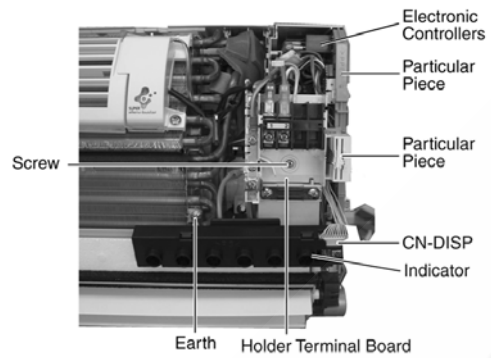

Fig. 3

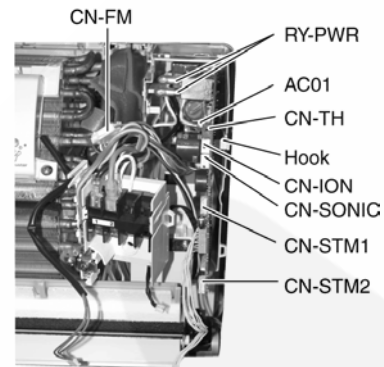

Fig. 4

12.3. Cross Flow Fan and Indoor Fan Motor Removal Procedures

1. In order to remove the Cross Flow Fan and Indoor Fan Motor, Control Board need to be taken out by releasing all the connectors as indicated below.

- a. Release the Earth Wire screw. (Fig. 5)
- b. Release the CN-TH connector. (Fig. 5)
- c. Release the CN-ION connector. (Fig. 5)
- d. Release the CN-SONIC connector. (Fig. 5)
- e. Release the CN-STM1 connector. (Fig. 5)
- f. Release the CN-STM2 connector. (Fig. 5)
- g. Release the CN-DISP connector. (Fig. 5)
- h. Pull out the Drain Hose from outlet to remove the Discharge Grille. (Fig. 5)

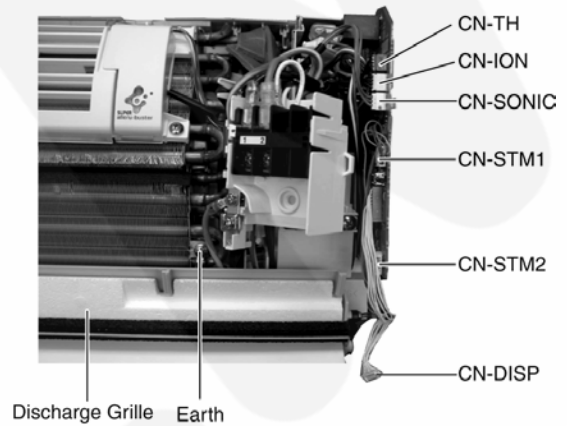

Fig. 5

2. Release the ION connectors. (Fig. 6)

3. Release the 3 screws. (Fig. 6)

4. By pressing down the hook at the left, you will be able to remove the Control Board. (Fig. 6)

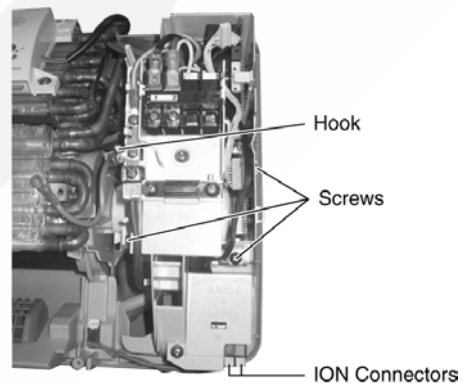

Fig. 6

5. Remove the screw at the Cross Flow Fan. (Fig. 7)

To reinstall the Fan Motor, please adjust the connector location is positioned 45° with Fan Motor before fixing Control Board Complete.

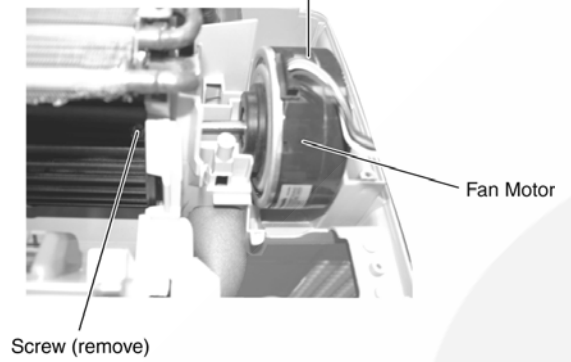

Fig. 7

6. Remove the Bearing. (Fig. 8)

7. Remove the screws at the left of the Evaporator. (Fig. 8)

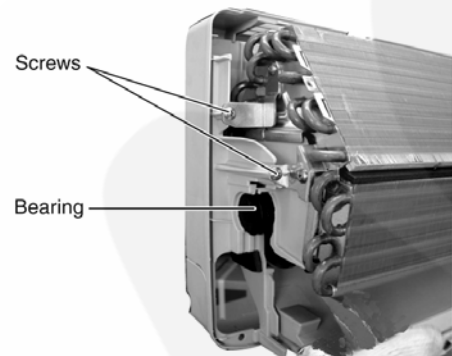

Fig. 8

8. Push up the Evaporator and pull out the Cross Flow Fan from shaft. By then, Fan Motor can be taken out. (Fig. 9)

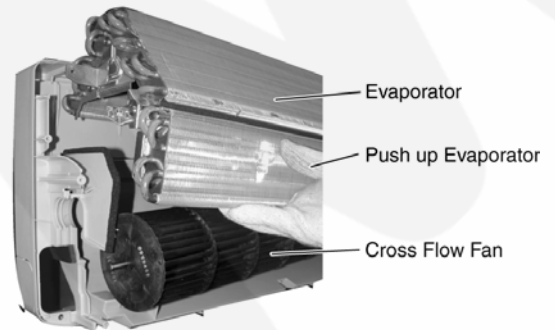
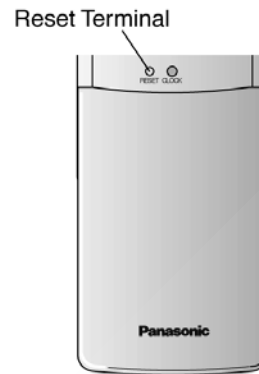

Fig. 9

REMINDER - To reinstall the Fan Motor, put it back in place, adjust the position of the Fan Motor's leadwire appropriately as shown in the Fig. 7 before installing the Cross Flow Fan.

12.4. Remote Control Reset

- When the batteries are inserted for the first time or the batteries are replaced, you may notice the indications at remote control's display screen blink continuously and not functionable. If this condition happens, try to reset the remote control by pushing the reset terminal with a pointing device.
- You may also do the reset to erase the setting at remote control and restore back the default setting.



12.5. Auto OFF/ON Button

- The "Auto OFF/ON Button" (behind the front grille) is used to operate the air conditioner if remote control is misplaced or malfunctioning.
- Forced cooling operation is possible by pressing the "Auto OFF/ON Button" for more than 5s where "beep" sound is heard then release the button.
- User able to select remote control transmission code and toggle remote control signal receiving sound under various setting mode.
- To enter various setting mode:
 - Press the "Auto OFF/ON Button" continuously for 5s ("beep" sound is heard) and release.
 - Within 20s, press the "Auto OFF/ON Button" continuously for 5s again (2 "beep" sound is heard) and release.
 - Various setting mode has limit up to 20s. Then return to normal operation.

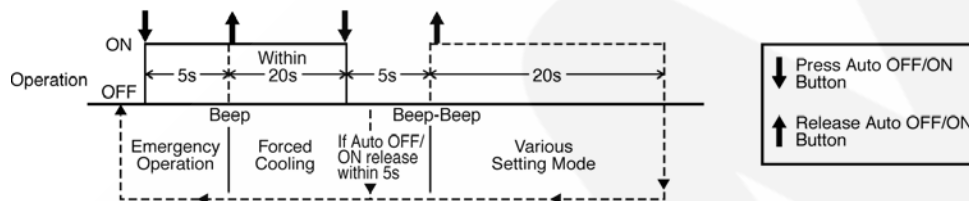

12.5.1. Toggle Remote Control Signal Receiving Sound

- Under various setting mode, press the "Auto OFF/ON Button" to toggle the remote control sound.
 - Short "beep": Turn ON remote control signal receiving sound.
 - Long "beep": Turn OFF remote control signal receiving sound.
- After "Auto OFF/ON Button" is pressed, the 20s counter for various setting mode is restarted.

12.5.2. Select Remote Control Transmission Code

- There are 4 types of remote control transmission code could be selected and stored in EEPROM of indoor unit. The indoor unit will only operate when received signal with same transmission code from remote control. This could prevent signal interference when there are 2 or more indoor unit installed nearby together.
- To change remote control transmission code, short or open jumpers at the remote control printed circuit board.

Remote Control Printed Circuit Board	Transmission Code Combination		
	J - A	J - B	Remote Control No.
	Short	Open	A (Default)
	Open	Open	B
	Short	Short	C
	Open	Short	D

- Under various setting mode, after select the transmission code combination of remote control, press any button of remote control to transmit a signal to indoor unit. The transmission code will be stored in EEPROM.
- After signal is received, the various setting mode is cancelled and return to normal operation.

13 Troubleshooting Guide

13.1. Refrigeration Cycle System

In order to diagnose malfunctions, make sure that there are no electrical problems before inspecting the refrigeration cycle. Such problems include insufficient insulation, problem with the power source, malfunction of a compressor and a fan.

The normal outlet air temperature and pressure of the refrigeration cycle depends on various conditions, the standard values for them are shown in the table on the right.

Normal Pressure and Outlet Air Temperature (Standard)

	Gas pressure Mpa (kg/cm ² G)	Outlet air temperature (°C)
Cooling Mode	0.9 ~ 1.2 (9 ~ 12)	10 ~ 16

* Condition: Indoor fan speed; High
Outdoor temperature 35°C

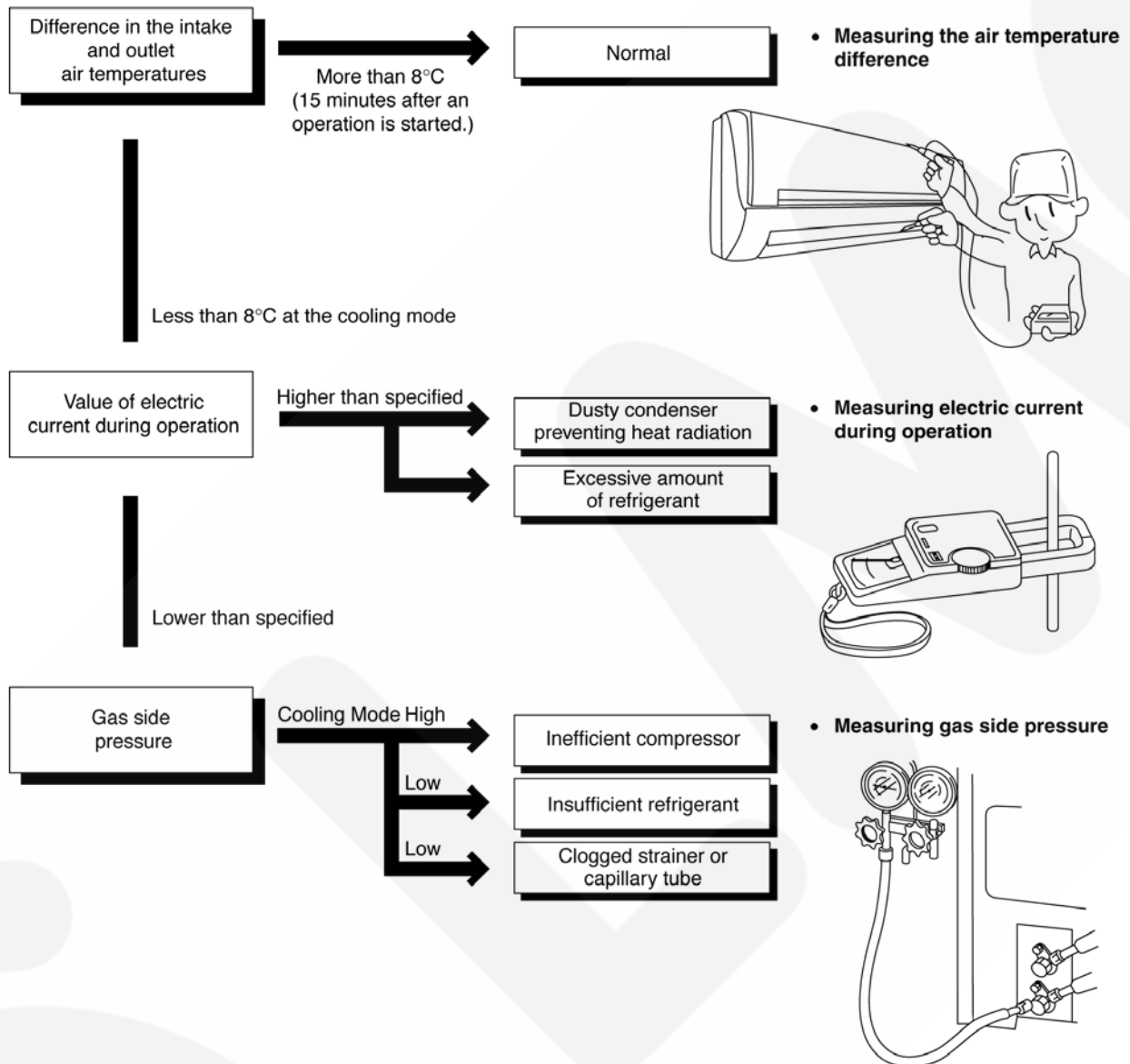

13.2. Relationship Between The Condition Of The Air Conditioner And Pressure And Electric Current

Condition of the air conditioner	Cooling Mode		
	Low Pressure	High Pressure	Electric current during operation
Insufficient refrigerant (gas leakage)	➔	➔	➔
Clogged capillary tube or Strainer	➔	➔	➔
Short circuit in the indoor unit	➔	➔	➔
Heat radiation deficiency of the outdoor unit	➔	➔	➔
Inefficient compression	➔	➔	➔

- Carry out the measurements of pressure, electric current, and temperature fifteen minutes after an operation is started.

13.3. Diagnosis Methods Of A Malfunction Of A Compressor And 4-way Valve

Nature of fault	Symptom
Insufficient compressing of a compressor	<ul style="list-style-type: none"> • Electric current during operation becomes approximately 20% lower than the normal value. • The discharge tube of the compressor becomes abnormally hot (normally 70 to 90°C). • The difference between high pressure and low pressure becomes almost zero.
Locked compressor	<ul style="list-style-type: none"> • Electric current reaches a high level abnormally, and the value exceeds the limit of an ammeter. In some cases, a breaker turns off. • The compressor is a humming sound.

14 Technical Data

14.1. Thermostat Characteristics

14.1.1. CS-V18DKE CS-V24DKE

• Cooling

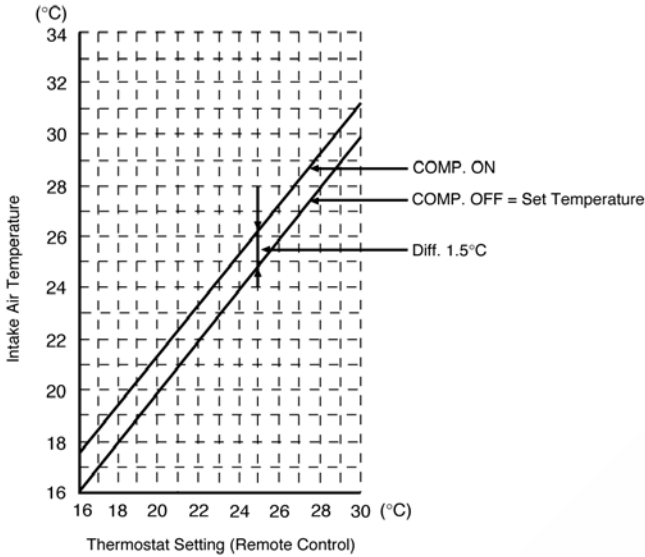

• Soft Dry

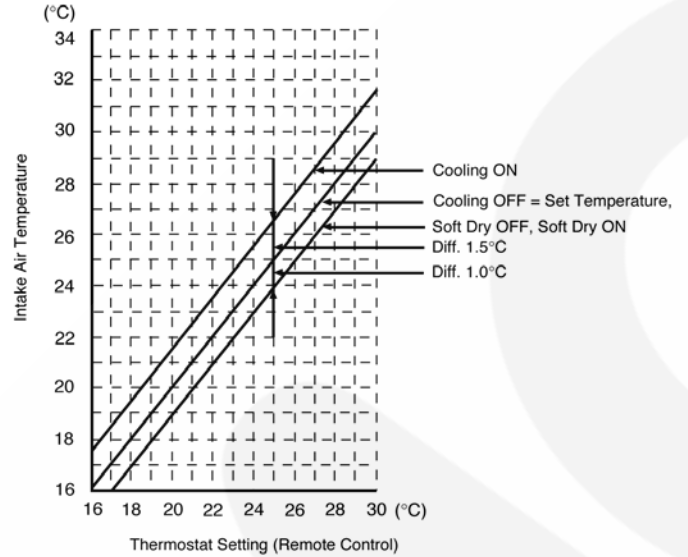

14.2. Sensible Capacity Chart

● CS-V18DKE

230V Indoor wet bulb temp.	Outdoor Temp. (°C)											
	30			35			40			46		
	TC	SHC	IP	TC	SHC	IP	TC	SHC	IP	TC	SHC	IP
17.0°C	5.26	3.99	1.49	4.91	3.82	1.61	4.57	3.67	1.72	4.16	3.49	1.85
19.0°C				5.30		1.63						
19.5°C	5.77	4.17	1.52	5.40	4.01	1.64	5.02	3.86	1.75	4.56	3.67	1.89
22.0°C	6.29	4.33	1.55	5.88	4.16	1.67	5.47	4.01	1.78	4.97	3.83	1.92

● CS-V24DKE

230V Indoor wet bulb temp.	Outdoor Temp. (°C)											
	30			35			40			46		
	TC	SHC	IP	TC	SHC	IP	TC	SHC	IP	TC	SHC	IP
17.0°C	6.97	5.29	2.38	6.52	5.07	2.56	6.06	4.87	2.74	5.51	4.63	2.96
19.0°C				7.03		2.60						
19.5°C	7.66	5.54	2.43	7.16	5.32	2.61	6.66	5.12	2.79	6.05	4.87	3.01
22.0°C	8.34	5.74	2.47	7.80	5.52	2.66	7.25	5.33	2.84	6.59	5.08	3.07

TC - Total Cooling Capacity (kW)
 SHC - Sensible Heat Capacity (kW)
 IP - Input Power (kW)

Indoor 27°C/19°C
 Outdoor 35°C/24°C

14.3. Operation Characteristics

14.3.1. CS-V18DKE CU-V18DKE

• Cooling Characteristic

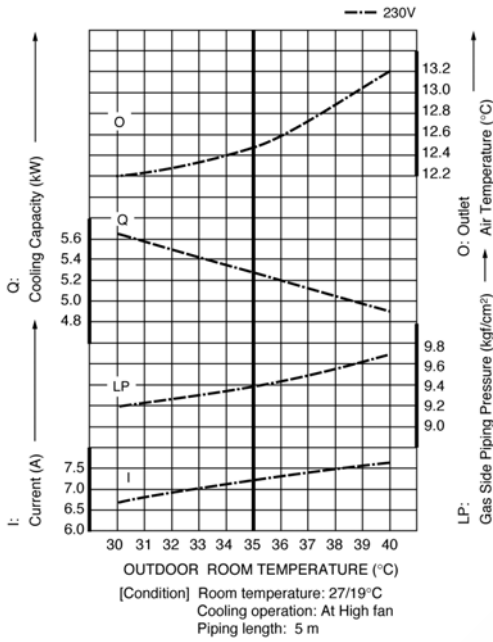

• Piping Length Characteristic (Cooling)

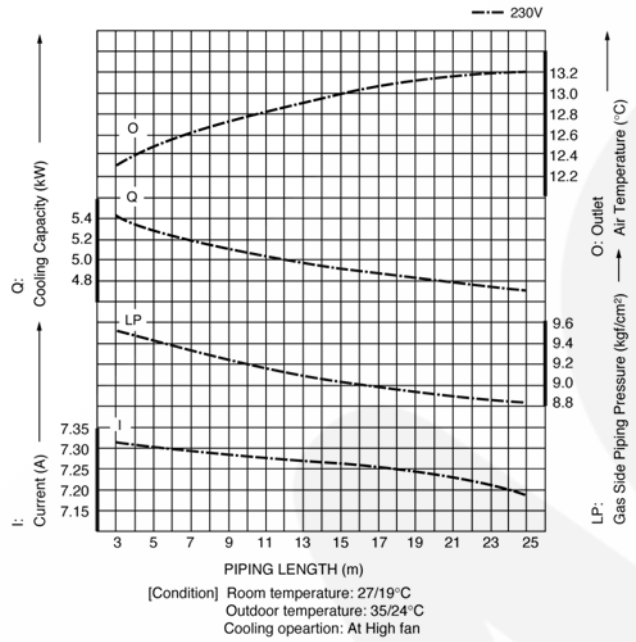

14.3.2. CS-V24DKE CU-V24DKE

• Cooling Characteristic

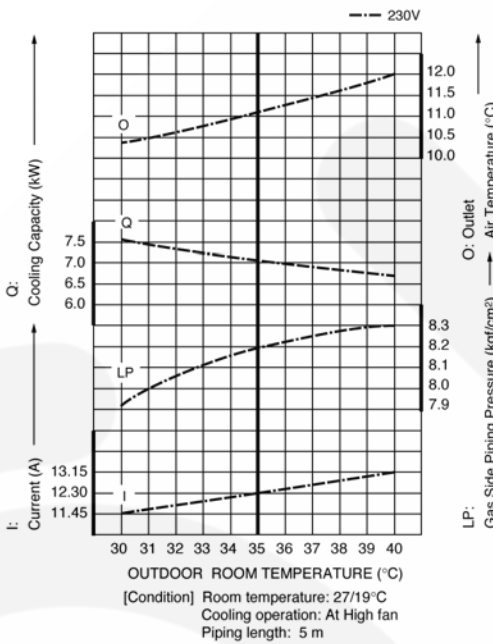

• Piping Length Characteristic (Cooling)

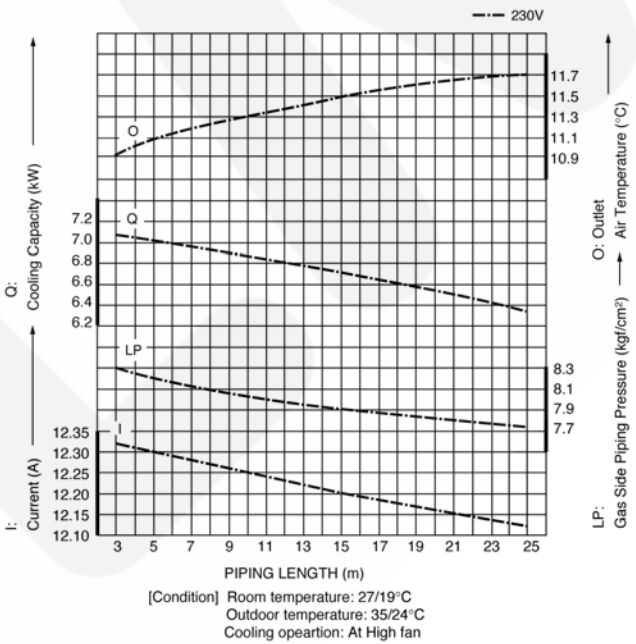

15 Exploded View (Indoor Unit)

15.1. CS-V18DKE CS-V24DKE

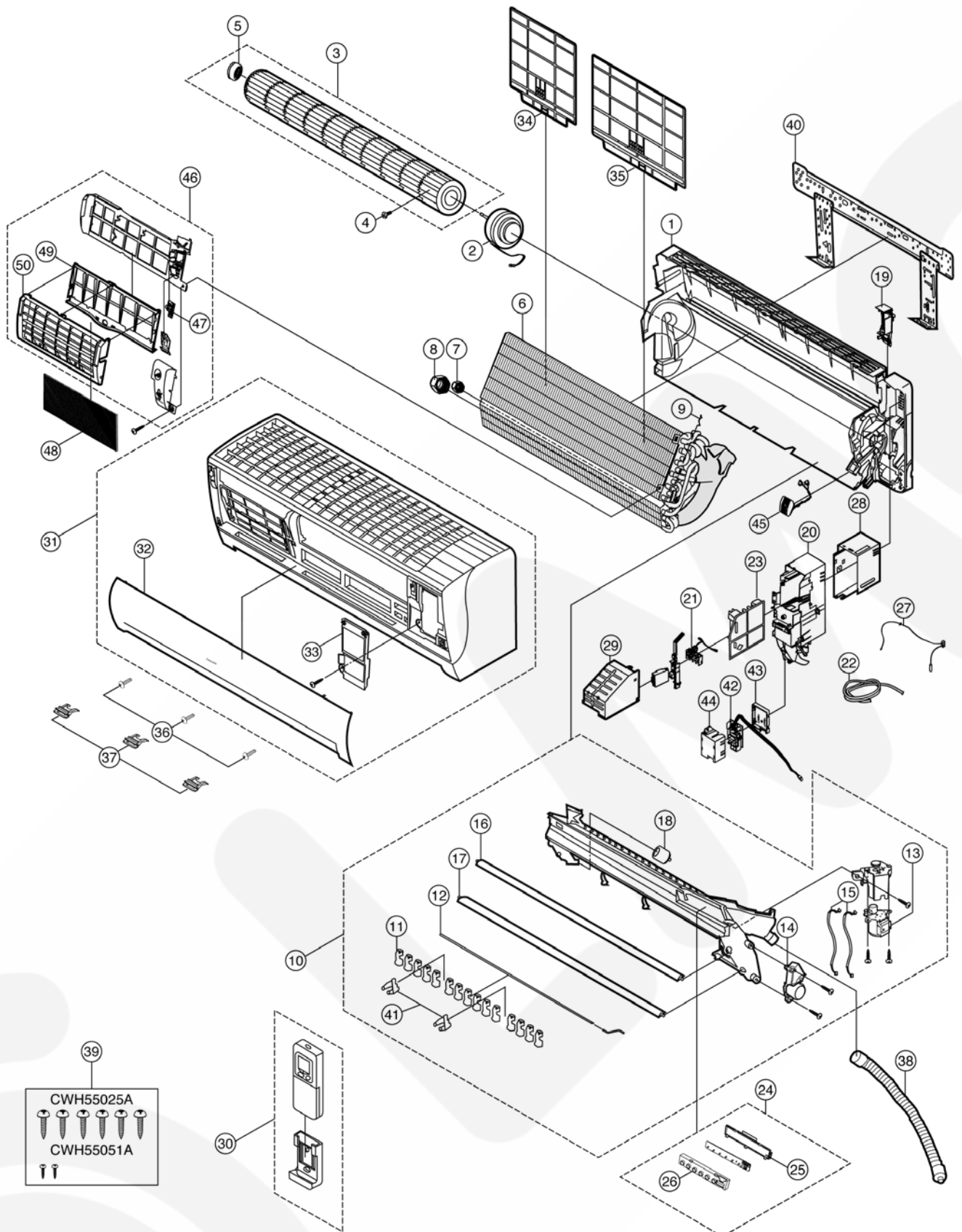

Note:

The above exploded view is for the purpose of parts disassembly and replacement.

The non-numbered parts are not kept as standard service parts.

16 Replacement Parts List (Indoor Unit)

16.1. CS-V18DKE CS-V24DKE

REF. NO.	PART NAME & DESCRIPTION	QTY.	CS-V18DKE	CS-V24DKE	REMARKS
1	CHASSY COMPLETE	1	CWD50C1382	←	
2	FAN MOTOR	1	CWA981149	←	0
3	CROSS FLOW FAN COMPLETE	1	CWH02C1010	←	
4	SCREW - CROSS FLOW FAN	1	CWH4580304	←	
5	BEARING ASS'Y	1	CWH64K007	←	
6	EVAPORATOR	1	CWB30C1641	CWB30C1643	
7	FLARE NUT	1	CWT25086 (1/4")	←	
8	FLARE NUT	1	CWT25096 (1/2")	CWT251016 (5/8")	
9	HOLDER SENSOR	1	CWH32143	←	
10	DISCHARGE GRILLE COMPLETE	1	CWE20C2345	←	
11	VERTICAL VANE	15	CWE241088	←	
12	CONNECTING BAR	1	CWE261025	←	
13	AIR SWING MOTOR	1	CWA98260	←	0
14	AIR SWING MOTOR	1	CWA98K1008	←	0
15	LEAD WIRE - FAN MOTOR	2	CWA67C3731	←	
16	HORIZONTAL VANE	1	CWE241152A	←	
17	HORIZONTAL VANE	1	CWE241153A	←	
18	CAP - DRAIN TRAY	1	CWH52C1001	←	
19	BACK COVER CHASSIS	1	CWD932162B	←	
20	CONTROL BOARD CASING	1	CWH102250	←	
21	TERMINAL BOARD COMPLETE	1	CWA28C2093	CWA28C2094	0
22	POWER SUPPLY CORD	1	CWA20C2422	CWA20C2349	
23	ELECTRONIC CONTROLLER - MAIN	1	CWA743490	CWA743489	0
24	INDICATOR & RECEIVER COMPLETE	1	CWE39C1116	←	0
25	INDICATOR HOLDER	1	CWD932435	←	
26	INDICATOR HOLDER	1	CWD932436	←	
27	SENSOR COMPLETE	1	CWA50C2122	←	0
28	CONTROL BOARD TOP COVER	1	CWH131209	←	
29	CONTROL BOARD FRONT COVER	1	CWH131210	←	
30	REMOTE CONTROL COMPLETE	1	CWA75C2620	←	0
31	FRONT GRILLE COMPLETE	1	CWE11C3126	←	0
32	INTAKE GRILLE COMPLETE	1	CWE22C1159	←	
33	GRILLE DOOR	1	CWE141076	←	
34	AIR FILTER (L)	1	CWD001137	←	
35	AIR FILTER (R)	1	CWD001138	←	
36	SCREW - FRONT GRILLE	3	XTT4+16C	←	
37	CAP - FRONT GRILLE	3	CWH521062A	←	
38	DRAIN HOSE	1	CWH851063	←	
39	BAG COMPLETE - INSTALLATION SCREW	1	CWH82C067	←	
40	INSTALLATION PLATE	1	CWH36K1007	←	
41	FULCRUM	2	CWH621047	←	
42	ELECTRONIC CONTROLLER - IONIZER	1	CWA743675	←	0
43	CASING - IONIZER	1	CWD932464	←	
44	CASING - IONIZER	1	CWD932527	←	
45	ION - GENERATOR	1	CWH94C0001	←	
46	SUPERSONIC AIR PURIFYING DEVICE	1	CWH91C1013	←	
47	ELEC.CONTROLLER-SUPERSONIC	1	CWA743874	←	0
48	SUPER ALLERU BUSTER FILTER	1	CWD00C1133	←	0
49	FRAME FR AIR FILTER SUPERSONIC	1	CWD011026	←	
50	FRAME FR AIR FILTER SUPERSONIC	1	CWD011027	←	

(Note)

- All parts are supplied from PHAAM, Malaysia (Vendor Code: 061).
- "O" marked parts are recommended to be kept in stock.

18 Replacement Parts List (Outdoor Unit)

18.1. CU-V18DKE CU-V24DKE

REF. NO.	PART NAME & DESCRIPTION	QTY.	CU-V18DKE	CU-V24DKE	REMARKS
1	CHASSY ASS'Y	1	CWD50K2115	CWD50K2100	
2	COMPRESSOR	1	5KS205DAH21	5JS315DAA21	0
3	ANTI - VIBRATION BUSHING	3	CWH50055	←	
4	NUT - COMPRESSOR MOUNT	3	CWH4582065	←	
5	PACKING	3	CWB81043	←	
6	CONDENSER	1	CWB32C1588	CWB32C1587	
7	SOUND PROOF BOARD ASS'Y	1	CWH151051	←	
8	FAN MOTOR BRACKET	1	CWD541065	←	
9	SCREW - FAN MOTOR BRACKET	2	CWH551060	←	
10	FAN MOTOR	1	CWA951360	CWA951383	0
11	SCREW - FAN MOTOR MOUNT	3	CWH55252	←	
12	PROPELLER FAN ASS'Y	1	CWH03K1017	←	
13	NUT - PROPELLER FAN	1	CWH561038	←	
14	HOLDER COUPLING ASS'Y	1	CWH351036	←	
15	2-WAY VALVE (LIQUID)	1	CWB021167	←	0
16	TUBE ASS'Y (CAPILLARY TUBE & STRAINER)	1	CWT023591	CWT023409	
17	3-WAY VALVE (GAS)	1	CWB011267	CWB011262	0
18	TERMINAL COVER	1	CWH171012	←	
19	NUT - TERMINAL COVER	1	CWH7080300	←	
20	CONTROL BOARD CASING	1	CWH102206	←	
21	CAPACITOR - FAN MOTOR	1	DS441355NPQA	DS441355BPQE	0
22	CAPACITOR - COMPRESSOR	1	DS371506CPNA	CWA312079	0
23	HOLDER CAPACITOR	1	CWH30060	←	
24	TERMINAL BOARD ASS'Y	1	CWA28K1064	←	
25	CABINET SIDE PLATE (L)	1	CWE041082A	←	
26	HANDLE	1	CWE161010	←	
27	CABINET SIDE PLATE (R)	1	CWE041083A	CWE041100A	
28	HANDLE	2	CWE16000E	←	
29	CABINET FRONT PLATE	1	CWE06K1043	←	
30	WIRE NET	1	CWD041041A	←	
31	CABINET TOP PLATE ASS'Y	1	CWE03K1009A	←	
32	CONTROL BOARD COVER	1	CWH131168	←	
33	CONTROL BOARD COVER	1	CWH131169A	←	
34	OPERATION INSTRUCTIONS (ENG., ESP., ITA., NED., POR., GRE., BUL.)	1	CWF564425	←	
35	INSTALLATION INSTRUCTIONS (ENG., ESP., FRA., DEU.)	1	CWF612632	←	
36	THERMOSTAT	1	-	CWA151040	
37	STRAINER	1	CWB11004	←	
38	SOUND PROOF MATERIAL	1	CWG302278	←	
39	OPERATION INSTRUCTIONS (FRA., DEU., SWE., NOR.)	1	CWF564510	←	
40	INSTALLATION INSTRUCTIONS (NED., GRE., ITA., POR.)	1	CWF612633	←	
41	INSTALLATION INSTRUCTIONS (BUL.)	1	CWF612683	←	
42	CHECK VALVE COMPLETE	1	CWB03C1022	CWB03C1023	

(Note)

- All parts are supplied from PHAAM, Malaysia (Vendor Code: 061).
- "O" marked parts are recommended to be kept in stock.

19 Electronic Circuit Diagram

19.1. Indoor Unit & Outdoor Unit

- CS-V18DKE CU-V18DKE
- CS-V24DKE CU-V24DKE

SCHEMATIC DIAGRAM 1/4

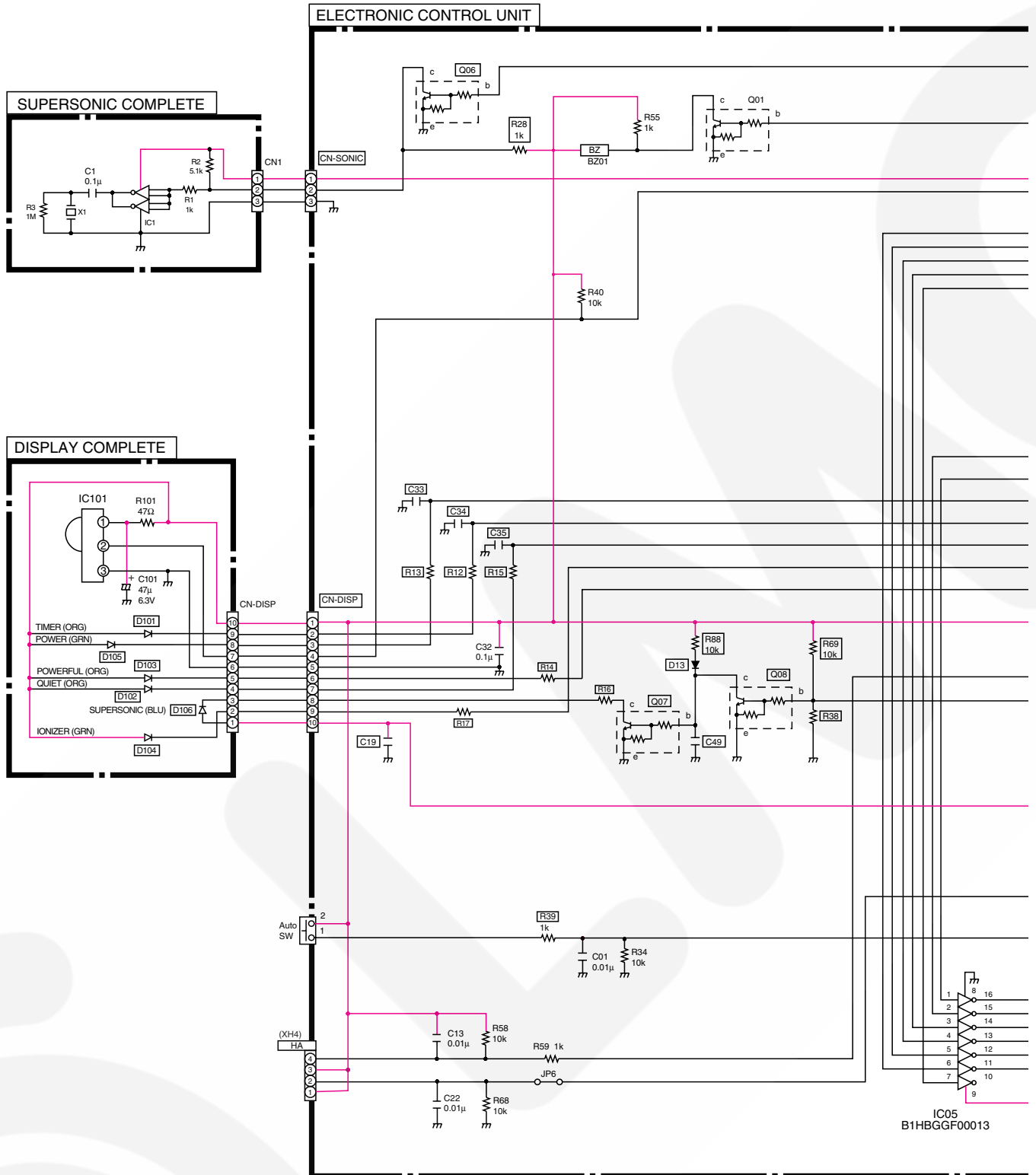

SCHEMATIC DIAGRAM 2/4

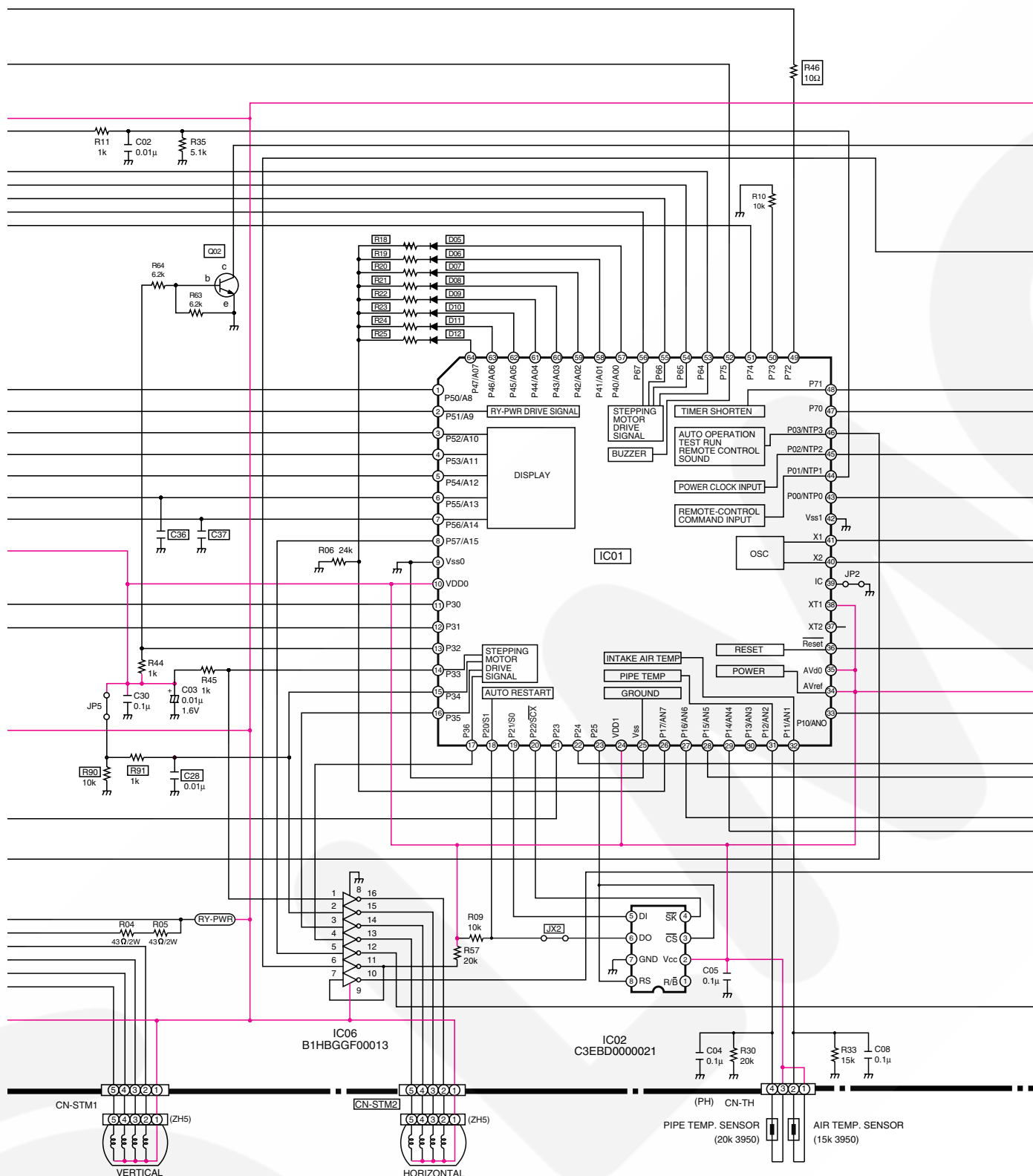

SCHEMATIC DIAGRAM 3/4

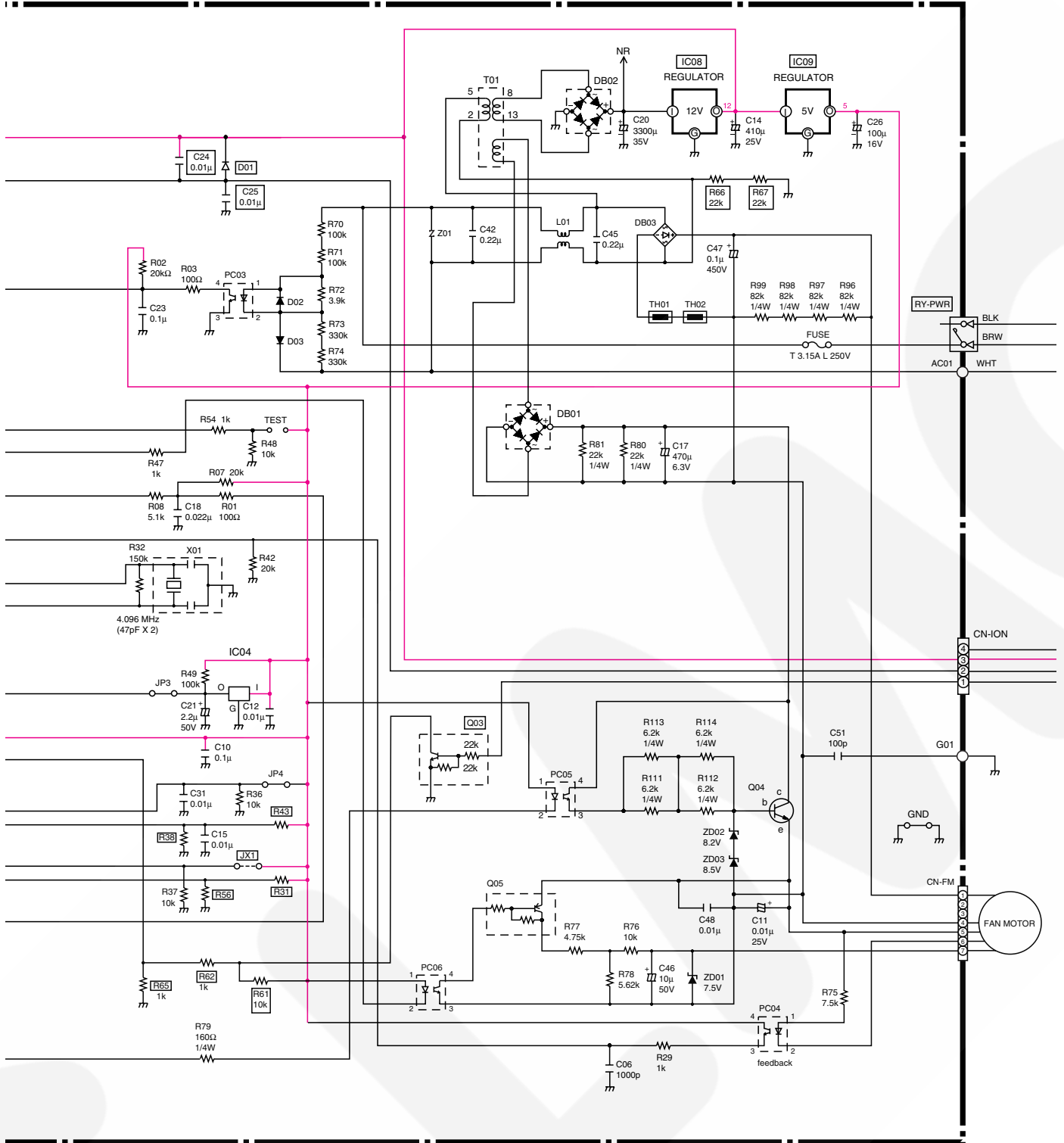

SCHEMATIC DIAGRAM 4/4

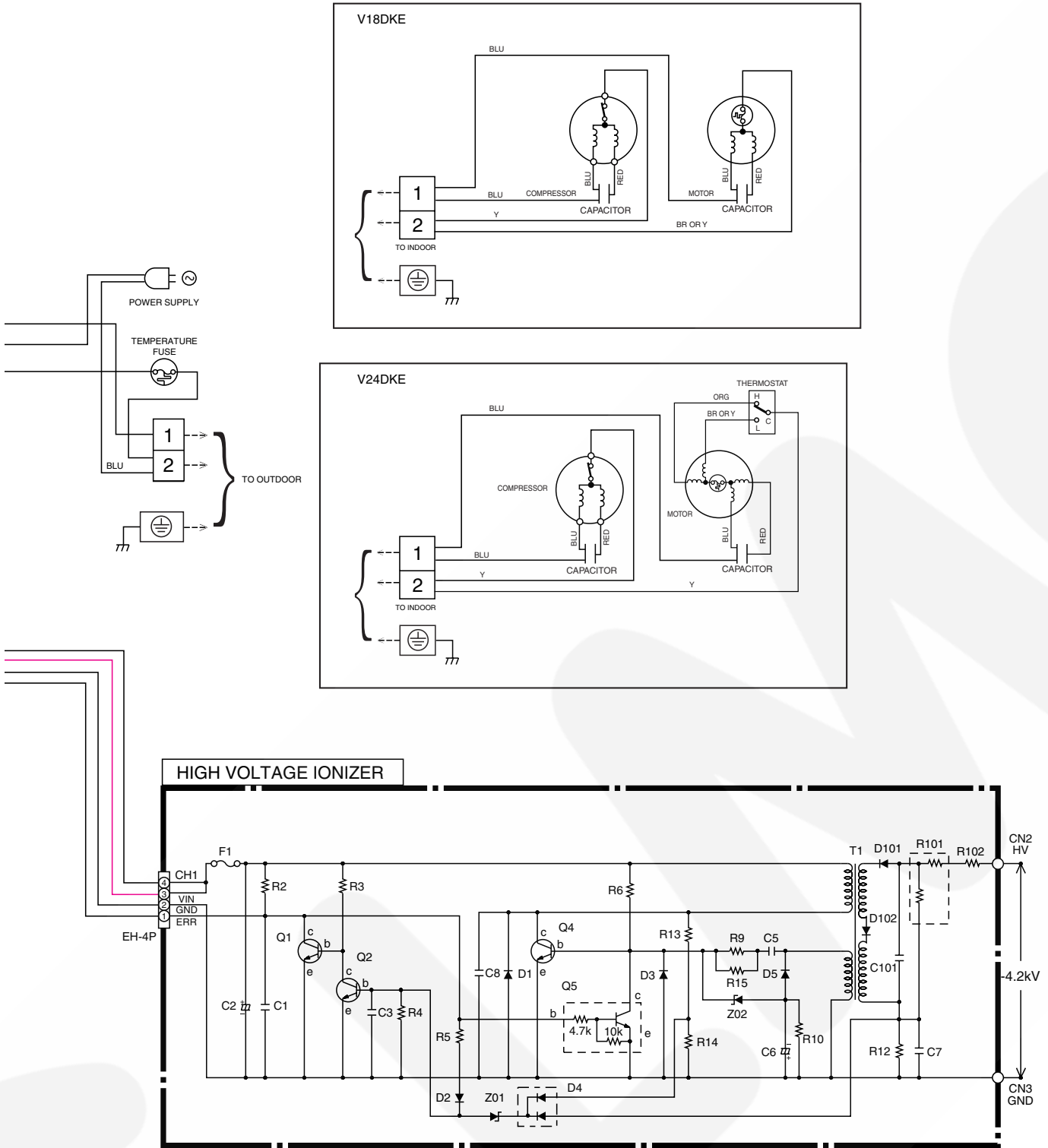

Fig. 1

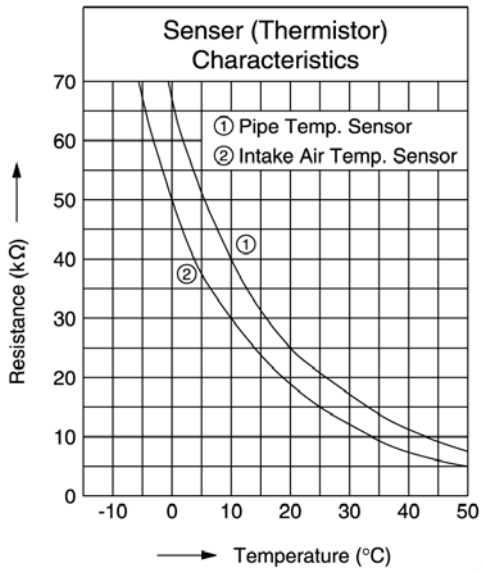
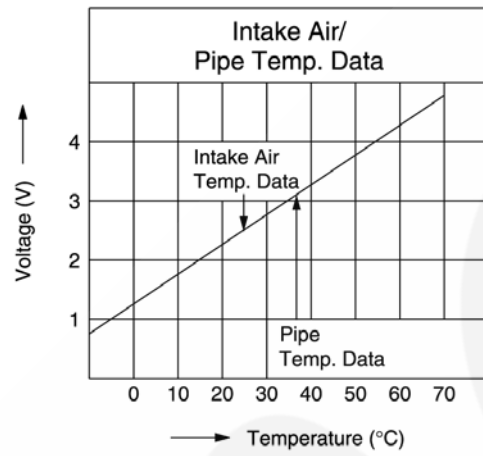

Fig. 2



How to use electronic circuit diagram

Before using the circuit diagram, read the following carefully.

* Voltage measurement

Voltage has been measured with a digital tester when the indoor fan is set at high fan speed under the following conditions without setting the timer.

Use them for servicing.

Voltage indication is in Red at all operations.

	Intake air temperature	Temperature setting	Discharge air temperature	Pipe temperature
Cooling	27°C	16°C	17°C	15°C

* Indications for resistance

a. K...kΩ M...MΩ
W...watt Not indicated....1/4W

b. Type

Not indicated.....carbon resister

Tolerance±5%



.....metal oxide resister

Tolerance±1%

* Indications for capacitor

a. Unit μ....μF P....pF

b. Type Not indicated....ceramic capacitor
(S).....S series aluminium electrolytic capacitor
(Z).....Z series aluminium electrolytic capacitor
(SU).....SU series aluminium electrolytic capacitor
(P).....P series polyester system
(SXE).....SXE series aluminium electrolytic capacitor
(SRA).....SRA series aluminium electrolytic capacitor
(KME).....KME series aluminium electrolytic capacitor

* Diode without indication.....MA165

※ Circuit Diagram is subject to change without notice for further development.

TIMER TABLE

Name	Time	Test Mode (When test point Short-circuited)	Remarks
Real Timer	1 hr.	1 min.	
	10 min.	10 sec.	
	1 min.	1 sec.	
Time Delay Safety Control	2 min. 58 sec.	0 sec.	
Forced Operation	60 sec.	0 sec.	
Time Save Control	7 min.	42 sec.	
Anti-Freezing	4 min.	0 sec.	
Auto Mode Judgement	25 sec.	0 sec.	
Soft Dry	OFF	6 min.	36 sec.
	ON	10 min.	60 sec.
Deodorizing Control	Cooling	40 sec.	4 sec.
		70 sec.	7 sec.
		20 sec.	2 sec.
		180 sec.	18 sec.
	Soft Dry	40 sec.	4 sec.
	360 sec.	36 sec.	
Comp. Reverse Rotation Detection	5 min.	30 sec.	Comp. ON 5 min. and above
	2 min.	0 sec.	
Comp./ Fan Motor Delay Timer	1.6 sec.	0 sec.	
Powerful Mode Operation	15 min.	15 sec.	
Random Auto Restart Control	0 ~ 62 sec.	0 ~ 6.2 sec.	
Ion OFF Timer	30 min.	180 sec.	
Ion ON Timer	10 sec.	1 sec.	
Quiet operation timer	1 hr. 30 min.	9 sec.	

19.2. Remote Control

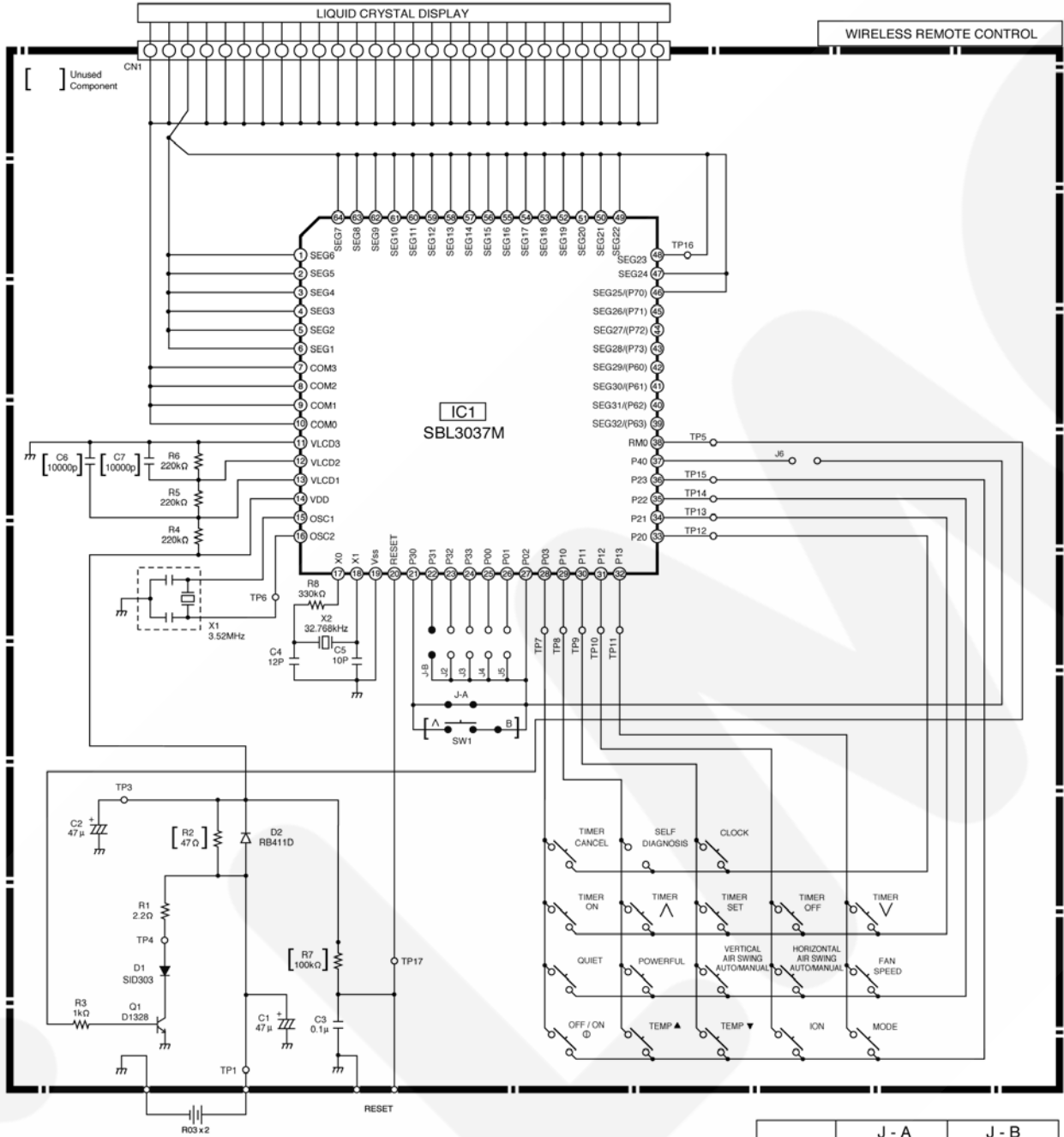

	J - A	J - B
0	SHORT	OPEN
1	OPEN	OPEN
2	SHORT	SHORT
3	OPEN	SHORT

19.3. Print Pattern Indoor Unit Printed Circuit Board

TOP VIEW

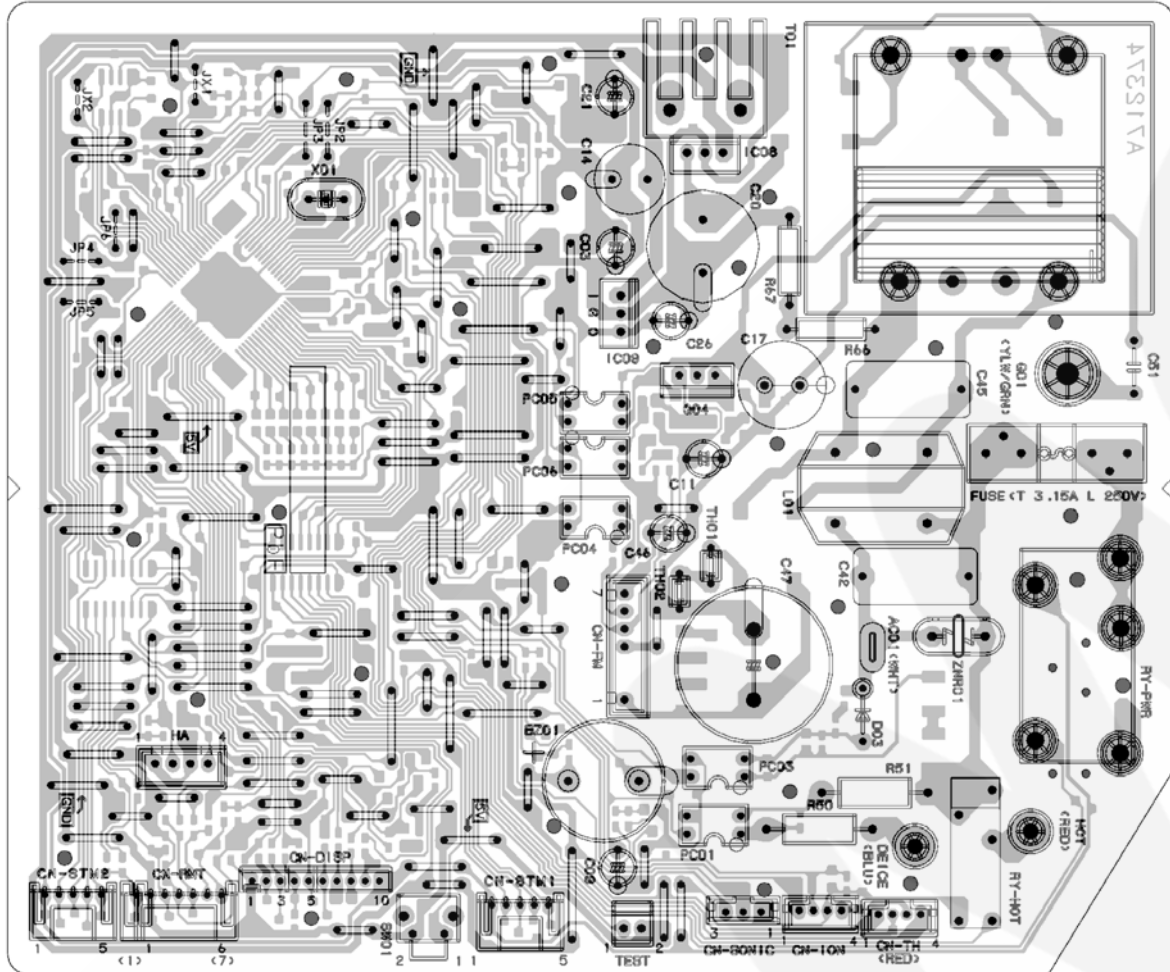

19.4. Print Pattern Indicator & Receiver Printed Circuit Board

TOP VIEW

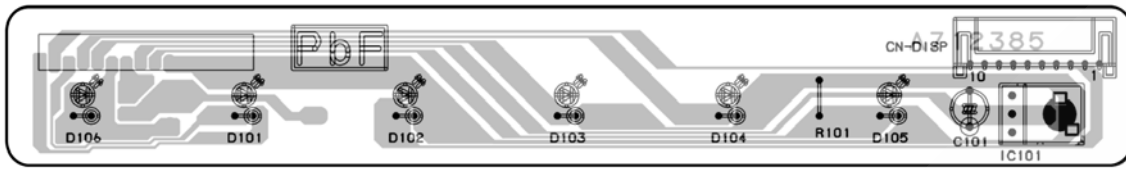

BOTTOM VIEW

