

# Service Manual

## Air Conditioner



**Indoor Unit**  
**CS-CE9NKE**  
**CS-CE12NKE**

**Outdoor Unit**  
**CU-CE9NKE**  
**CU-CE12NKE**

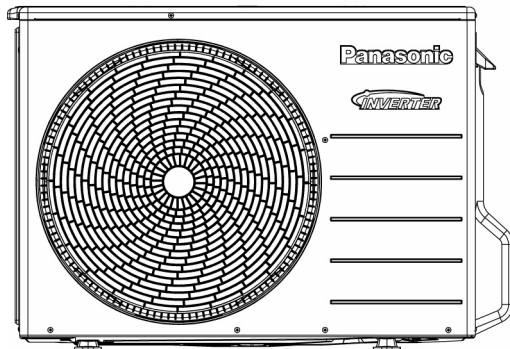

### **⚠ WARNING**

This service information is designed for experienced repair technicians only and is not designed for use by the general public. It does not contain warnings or cautions to advise non-technical individuals of potential dangers in attempting to service a product. Products powered by electricity should be serviced or repaired only by experienced professional technicians. Any attempt to service or repair the product or products dealt with in this service information by anyone else could result in serious injury or death.

### **⚠ PRECAUTION OF LOW TEMPERATURE**

In order to avoid frostbite, be assured of no refrigerant leakage during the installation or repairing of refrigerant circuit.

## TABLE OF CONTENTS



<b>1. Safety Precautions</b> .....	<b>3</b>	8.2 Outdoor Unit .....	18
<b>2. Specifications</b> .....	<b>5</b>	<b>9. Electronic Circuit Diagram</b> .....	<b>19</b>
<b>3. Features</b> .....	<b>11</b>	9.1 Indoor Unit .....	19
<b>4. Location of Controls and Components</b> .....	<b>12</b>	9.2 Outdoor Unit .....	20
4.1 Indoor Unit .....	12	<b>10. Printed Circuit Board</b> .....	<b>21</b>
4.2 Outdoor Unit .....	12	10.1 Indoor Unit .....	21
4.3 Remote Control .....	12	10.2 Outdoor Unit .....	22
<b>5. Dimensions</b> .....	<b>13</b>	<b>11. Installation Instruction</b> .....	<b>23</b>
5.1 Indoor Unit .....	13	11.1 Select the Best Location .....	23
5.2 Outdoor Unit .....	14	11.2 Indoor Unit .....	24
<b>6. Refrigeration Cycle Diagram</b> .....	<b>15</b>	11.3 Outdoor Unit .....	28
<b>7. Block Diagram</b> .....	<b>16</b>	<b>12. Operation and Control</b> .....	<b>30</b>
<b>8. Wiring Connection Diagram</b> .....	<b>17</b>	12.1 Basic Function .....	30
8.1 Indoor Unit .....	17	12.2 Indoor Fan Motor Operation .....	31
		12.3 Outdoor Fan Motor Operation .....	32

# Panasonic®

12.4	Airflow Direction.....	32
12.5	Timer Control.....	33
12.6	Auto Restart Control.....	34
12.7	Indication Panel.....	34
<b>13.</b>	<b>Protection Control.....</b>	<b>35</b>
13.1	Protection Control For All Operations.....	35
13.2	Protection Control For Cooling & Soft Dry Operation.....	37
13.3	Protection Control For Heating Operation.....	38
<b>14.</b>	<b>Servicing Mode.....</b>	<b>40</b>
14.1	Auto OFF/ON Button.....	40
14.2	Remote Control Button.....	41
<b>15.</b>	<b>Troubleshooting Guide.....</b>	<b>42</b>
15.1	Refrigeration Cycle System.....	42
15.2	Breakdown Self Diagnosis Function.....	44
15.3	Error Codes Table.....	45
15.4	Self-diagnosis Method.....	47
<b>16.</b>	<b>Disassembly and Assembly Instructions.....</b>	<b>69</b>
16.1	Indoor Electronic Controllers, Cross Flow Fan and Indoor Fan Motor Removal Procedures.....	69
16.2	Outdoor Electronic Controller Removal Procedure.....	73
<b>17.</b>	<b>Technical Data.....</b>	<b>74</b>
17.1	Operation Characteristics.....	74
17.2	Sensible Capacity Chart.....	82
<b>18.</b>	<b>Exploded View and Replacement Parts List.....</b>	<b>83</b>
18.1	Indoor Unit.....	83
18.2	Outdoor Unit.....	86

# 1. Safety Precautions







- Read the following “SAFETY PRECAUTIONS” carefully before perform any servicing.
- Electrical work must be installed or serviced by a licensed electrician. Be sure to use the correct rating of the power plug and main circuit for the model installed.
- The caution items stated here must be followed because these important contents are related to safety. The meaning of each indication used is as below. Incorrect installation or servicing due to ignoring of the instruction will cause harm or damage, and the seriousness is classified by the following indications.

 <b>WARNING</b>	This indication shows the possibility of causing death or serious injury.
 <b>CAUTION</b>	This indication shows the possibility of causing injury or damage to properties.

- The items to be followed are classified by the symbols:

	This symbol denotes item that is PROHIBITED from doing.
---	---





- Carry out test run to confirm that no abnormality occurs after the servicing. Then, explain to user the operation, care and maintenance as stated in instructions. Please remind the customer to keep the operating instructions for future reference.

 <b>WARNING</b>	
1. Do not modify the machine, part, material during repairing service.	
2. If wiring unit is supplied as repairing part, do not repair or connect the wire even only partial wire break. Exchange the whole wiring unit.	
3. Do not wrench the fasten terminal. Pull it out or insert it straightly.	
4. Engage authorized dealer or specialist for installation and servicing. If installation or servicing done by the user is defective, it will cause water leakage, electrical shock or fire.	
5. Install according to this installation instructions strictly. If installation is defective, it will cause water leakage, electric shock or fire.	
6. Use the attached accessories parts and specified parts for installation and servicing. Otherwise, it will cause the set to fall, water leakage, fire or electrical shock.	
7. Install at a strong and firm location which is able to withstand the set's weight. If the strength is not enough or installation is not properly done, the set will drop and cause injury.	
8. For electrical work, follow the local national wiring standard, regulation and the installation instruction. An independent circuit and single outlet must be used. If electrical circuit capacity is not enough or defect found in electrical work, it will cause electrical shock or fire.	
9. This equipment is strongly recommended to be installed with Earth Leakage Circuit Breaker (ELCB) or Residual Current Device (RCD). Otherwise, it may cause electrical shock and fire in case equipment breakdown or insulation breakdown.	
10. Do not use joint cable for indoor/outdoor connection cable. Use the specified indoor/outdoor connection cable, refer to installation instruction CONNECT THE CABLE TO THE INDOOR UNIT and connect tightly for indoor/outdoor connection. Clamp the cable so that no external force will be acted on the terminal. If connection or fixing is not perfect, it will cause heat up or fire at the connection.	
11. Wire routing must be properly arranged so that control board cover is fixed properly. If control board cover is not fixed perfectly, it will cause heat-up or fire at the connection point of terminal, fire or electrical shock.	
12. When install or relocate air conditioner, do not let any substance other than the specified refrigerant, eg. air etc. mix into refrigeration cycle (piping). (Mixing of air etc. will cause abnormal high pressure in refrigeration cycle and result in explosion, injury etc.).	
13. Do not install outdoor unit near handrail of veranda. When installing air-conditioner unit at veranda of high rise building, child may climb up to outdoor unit and cross over the handrail and causing accident.	
14. This equipment must be properly earthed. Earth line must not be connected to gas pipe, water pipe, earth of lightning rod and telephone. Otherwise, it may cause electric shock in case equipment breakdown or insulation breakdown.	
15. Keep away from small children, the thin film may cling to nose and mouth and prevent breathing.	
16. Do not use unspecified cord, modified cord, joint cord or extension cord for power supply cord. Do not share the single outlet with other electrical appliances. Poor contact, poor insulation or over current will cause electrical shock or fire.	
17. Tighten the flare nut with torque wrench according to specified method. If the flare nut is over-tightened, after a long period, the flare may break and cause refrigerant gas leakage.	
18. For R410A models, when connecting the piping, do not use any existing (R22) pipes and flare nuts. Using such same may cause abnormally high pressure in the refrigeration cycle (piping), and possibly result in explosion and injury. Use only R410A materials. Thickness of copper pipes used with R410A must be more than 0.8mm. Never use copper pipes thinner than 0.8mm. It is desirable that the amount of residual oil is less than 40 mg/10m.	

 **WARNING**

- |   |   |
|---|---|
| 19. During installation, install the refrigerant piping properly before run the compressor. (Operation of compressor without fixing refrigeration piping and valves at opened condition will cause suck-in of air, abnormal high pressure in refrigeration cycle and result in explosion, injury etc).    |   |
| 20. During pump down operation, stop the compressor before remove the refrigeration piping. (Removal of refrigeration piping while compressor is operating and valves are opened condition will cause suck-in of air, abnormal high pressure in refrigeration cycle and result in explosion, injury etc.) |   |
| 21. After completion of installation or service, confirm there is no leakage or refrigerant gas. It may generate toxic gas when the refrigerant contacts with fire.   |   |
| 22. Ventilate if there is refrigerant gas leakage during operation. It may cause toxic gas when the refrigerant contacts with fire.   |   |
| 23. Do not insert your fingers or other objects into the unit, high speed rotating fan may cause injury.  |  |
| 24. Must not use other parts except original parts describe in catalog and manual.  |   |
| 25. Using of refrigerant other than the specified type may cause product damage, burst and injury etc.  |   |

 **CAUTION**

- |   |   |
|---|---|
| 1. Do not install the unit at place where leakage of flammable gas may occur. In case gas leaks and accumulates at surrounding of the unit, it may cause fire.  |    |
| 2. Carry out drainage piping as mentioned in installation instructions. If drainage is not perfect, water may enter the room and damage the furniture.  |   |
| 3. Tighten the flare nut with torque wrench according to specified method. If the flare nut is over-tightened, after a long period, the flare may break and cause refrigerant gas leakage.  |   |
| 4. Do not touch outdoor unit air inlet and aluminium fin. It may cause injury.  |    |
| 5. Select an installation location which is easy for maintenance.   |   |
| 6. Pb free solder has a higher melting point than standard solder; typically the melting point is 50°F – 70°F (30°C – 40°C) higher. Please use a high temperature solder iron. In case of the soldering iron with temperature control, please set it to 700 ± 20°F (370 ± 10°C). Pb free solder will tend to splash when heated too high (about 1100°F / 600°C).  |   |
| 7. Power supply connection to the room air conditioner.<br>Use power supply cord 3 x 1.5 mm <sup>2</sup> type designation 245 IEC 57 or heavier cord.<br>Connect the power supply cord of the air conditioner to the mains using one of the following method.<br>Power supply point should be in easily accessible place for power disconnection in case of emergency.<br>In some countries, permanent connection of this air conditioner to the power supply is prohibited.<br>1) Power supply connection to the receptacle using power plug.<br>Use an approved 15/16A power plug with earth pin for the connection to the socket.<br>2) Power supply connection to a circuit breaker for the permanent connection.<br>Use an approved 16A circuit breaker for the permanent connection. It must be a double pole switch with a minimum 3.0 mm contact gap. |   |
| 8. Do not release refrigerant during piping work for installation, servicing, reinstallation and during repairing a refrigerant parts.<br>Take care of the liquid refrigerant, it may cause frostbite.  |  |
| 9. Installation or servicing work: It may need two people to carry out the installation or servicing work.  |   |
| 10. Do not install this appliance in a laundry room or other location where water may drip from the ceiling, etc.   |  |
| 11. Do not sit or step on the unit, you may fall down accidentally.   |  |
| 12. Do not touch the sharp aluminium fins or edges of metal parts.<br>If you are required to handle sharp parts during installation or servicing, please wear hand glove.<br>Sharp parts may cause injury.  |   |



## 2. Specifications

MODEL		INDOOR	CS-CE9NKE		
		OUTDOOR	CU-CE9NKE		
Performance Test Condition		EUROVENT			
Power Supply		Phase, Hz	Single, 50		
		V	230		
		Min.	Mid.	Max.	
Cooling	Capacity	kW	0.85	2.50	3.00
		BTU/h	2900	8530	10200
		kcal/h	730	2150	2580
	Running Current	A	-	2.6	-
	Input Power	W	190	545	740
	Annual Consumption	kWh	-	273	-
	EER	W/W	4.47	4.59	4.05
		BTU/hW	15.26	15.65	13.78
		kcal/hW	3.84	3.94	3.49
	Power Factor	%	-	91	-
	Indoor Noise (H / L)	dB-A	39 / 25		
		Power Level dB	55 / 41		
	Outdoor Noise (H / L)	dB-A	46 / -		
		Power Level dB	61 / -		
Heating	Capacity	kW	0.85	3.40	5.00
		BTU/h	2900	11600	17100
		kcal/h	730	2920	4300
	Running Current	A	-	3.5	-
	Input Power	W	185	740	1.33k
	COP	W/W	4.59	4.59	3.76
		BTU/hW	15.68	15.68	12.86
		kcal/hW	3.95	3.95	3.23
	Power Factor	%	-	92	-
	Indoor Noise (H / L)	dB-A	40 / 27		
		Power Level dB	56 / 43		
Outdoor Noise (H / L)	dB-A	47 / -			
	Power Level dB	62 / -			
Low Temp. : Capacity (kW) / I. Power (W) / COP		3.62 / 1.18k / 3.07			
Extr Low Temp. : Capacity (kW) / I. Power (W) / COP		3.12 / 1.20k / 2.60			
Max Current (A) / Max Input Power (W)		7.9 / 1.75k			
Starting Current (A)		3.5			
Compressor	Type	Hermetic Motor (Rotary)			
	Motor Type	Brushless (4 poles)			
	Output Power	W	900		

Indoor Fan	Type		Cross-flow Fan		
	Material		ASG20K1		
	Motor Type		Transistor (8-poles)		
	Input Power		W	47	
	Output Power		W	40	
	Speed	Lo	Cool/Fan	rpm	690
			Heat	rpm	750
		Me	Cool/Fan	rpm	890
			Heat	rpm	980
Hi		Cool/Fan	rpm	1090	
		Heat	rpm	1200	
Outdoor Fan	Type		Propeller Fan		
	Material		PP		
	Motor Type		AC Type (6-poles)		
	Input Power		W	-	
	Output Power		W	25	
	Speed	Hi	Cool	rpm	840
			Heat	rpm	840
Moisture Removal		L/h (Pt/h)	1.5 (3.2)		
Indoor Airflow	Lo	Cool/Fan	m <sup>3</sup> /min (ft <sup>3</sup> /min)	6.58 (230)	
		Heat	m <sup>3</sup> /min (ft <sup>3</sup> /min)	7.27 (260)	
	Me	Cool/Fan	m <sup>3</sup> /min (ft <sup>3</sup> /min)	8.88 (310)	
		Heat	m <sup>3</sup> /min (ft <sup>3</sup> /min)	9.91 (350)	
	Hi	Cool/Fan	m <sup>3</sup> /min (ft <sup>3</sup> /min)	11.3 (400)	
		Heat	m <sup>3</sup> /min (ft <sup>3</sup> /min)	11.9 (420)	
Outdoor Airflow	Hi	Cool	m <sup>3</sup> /min (ft <sup>3</sup> /min)	31.3 (1105)	
		Heat	m <sup>3</sup> /min (ft <sup>3</sup> /min)	31.3 (1105)	
Refrigeration Cycle	Control Device		Check Valve & Capillary Tube		
	Refrigerant Oil		cm <sup>3</sup>	FV50S (450)	
	Refrigerant Type		g (oz)	R410A, 1.00k (35.3)	
Dimension	Height (I/D / O/D)		mm (inch)	290 (11-7/16) / 622 (24-1/2)	
	Width (I/D / O/D)		mm (inch)	870 (34-9/32) / 824 (32-15/32)	
	Depth (I/D / O/D)		mm (inch)	214 (8-7/16) / 299 (11-25/32)	
Weight	Net (I/D / O/D)		kg (lb)	9 (20) / 36 (79)	
Piping	Pipe Diameter (Liquid / Gas)		mm (inch)	6.35 (1/4) / 9.52 (3/8)	
	Standard length		m (ft)	5.0 (16.4)	
	Length Range (min – max)		m (ft)	3 (9.8) ~ 15 (49.2)	
	I/D & O/D Height Different		m (ft)	5.0 (16.4)	
	Additional Gas Amount		g/m (oz/ft)	20 (0.2)	
	Length for Additional Gas		m (ft)	7.5 (24.6)	
Drain Hose	Inner Diameter		mm	16	
	Length		mm	650	
Indoor Heat Exchanger	Fin Material		Aluminium (Pre Coat)		
	Fin Type		Slit Fin		
	Row x Stage x FPI		2 x 15 x 19		
	Size (W x H x L)		mm	610 x 315 x 25.4	
Outdoor Heat Exchanger	Fin Material		Aluminium		
	Fin Type		Corrugated Fin		
	Row x Stage x FPI		2 x 28 x 17		
	Size (W x H x L)		mm	36.4 x 588 x 606.6	

Air Filter	Material		Polypropelene	
	Type		One-touch	
Power Supply			Indoor Power Supply	
Power Supply Cord		A	Nil	
Thermostat			Electronic Control	
Protection Device			Electronic Control	
			Dry Bulb	Wet Bulb
Indoor Operation Range	Cooling	Maximum	32	23
		Minimum	16	11
	Heating	Maximum	30	-
		Minimum	16	-
Outdoor Operation Range	Cooling	Maximum	43	26
		Minimum	16	11
	Heating	Maximum	24	18
		Minimum	-15	-16

1. Cooling capacities are based on indoor temperature of 27°C Dry Bulb (80.6°F Dry Bulb), 19.0°C Wet Bulb (66.2°F Wet Bulb) and outdoor air temperature of 35°C Dry Bulb (95°F Dry Bulb), 24°C Wet Bulb (75.2°F Wet Bulb)
2. Heating capacities are based on indoor temperature of 20°C Dry Bulb (68°F Dry Bulb) and outdoor air temperature of 7°C Dry Bulb (44.6°F Dry Bulb), 6°C Wet Bulb (42.8°F Wet Bulb)
3. Heating low temperature capacity, Input Power and COP measured at 230 V, indoor temperature 20°C, outdoor 2/1°C
4. Heating extreme low temperature capacity, Input Power and COP measured at 230 V, indoor temperature 20°C, outdoor -7/-8°C
5. Specifications are subjected to change without prior notice for further improvement.

MODEL		INDOOR	CS-CE12NKE		
		OUTDOOR	CU-CE12NKE		
Performance Test Condition		EUROVENT			
Power Supply		Phase, Hz	Single, 50		
		V	230		
		Min.	Mid.	Max.	
Cooling	Capacity	kW	0.85	3.50	4.00
		BTU/h	2900	11900	13600
		kcal/h	730	3010	3440
	Running Current	A	-	4.4	-
	Input Power	W	195	950	1.16k
	Annual Consumption	kWh	-	475	-
	EER	W/W	4.36	3.68	3.45
		BTU/hW	14.87	12.53	11.72
		kcal/hW	3.74	3.17	2.97
	Power Factor	%	-	94	-
	Indoor Noise (H / L)	dB-A	42 / 28		
		Power Level dB	58 / 44		
	Outdoor Noise (H / L)	dB-A	48 / -		
		Power Level dB	63 / -		
Heating	Capacity	kW	0.85	4.00	6.50
		BTU/h	2900	13600	22200
		kcal/h	730	3440	5590
	Running Current	A	-	4.6	-
	Input Power	W	190	990	1.89k
	COP	W/W	4.47	4.04	3.44
		BTU/hW	15.26	13.74	11.75
		kcal/hW	3.84	3.47	2.96
	Power Factor	%	-	94	-
	Indoor Noise (H / L)	dB-A	42 / 33		
		Power Level dB	58 / 49		
	Outdoor Noise (H / L)	dB-A	50 / -		
		Power Level dB	65 / -		
	Low Temp. : Capacity (kW) / I. Power (W) / COP		4.71 / 1.65k / 2.85		
Extr Low Temp. : Capacity (kW) / I. Power (W) / COP		3.90 / 1.80k / 2.17			
Max Current (A) / Max Input Power (W)		8.6 / 1.89k			
Starting Current (A)		4.6			
Compressor	Type	Hermetic Motor (Rotary)			
	Motor Type	Brushless (4 poles)			
	Output Power	W	900		

Indoor Fan	Type			Cross-flow Fan	
	Material			ASG20K1	
	Motor Type			Transistor (8-poles)	
	Input Power		W	47	
	Output Power		W	40	
	Speed	Lo	Cool/Fan	rpm	790
			Heat	rpm	990
		Me	Cool/Fan	rpm	1020
			Heat	rpm	1140
		Hi	Cool/Fan	rpm	1240
Heat			rpm	1280	
Outdoor Fan	Type			Propeller Fan	
	Material			PP	
	Motor Type			AC Type (6-poles)	
	Input Power		W	-	
	Output Power		W	30	
	Speed	Hi	Cool	rpm	880
			Heat	rpm	880
Moisture Removal		L/h (Pt/h)		2.0 (4.2)	
Indoor Airflow	Lo	Cool/Fan	m <sup>3</sup> /min (ft <sup>3</sup> /min)	7.48 (260)	
		Heat	m <sup>3</sup> /min (ft <sup>3</sup> /min)	9.72 (340)	
	Me	Cool/Fan	m <sup>3</sup> /min (ft <sup>3</sup> /min)	10.06 (360)	
		Heat	m <sup>3</sup> /min (ft <sup>3</sup> /min)	11.40 (400)	
	Hi	Cool/Fan	m <sup>3</sup> /min (ft <sup>3</sup> /min)	12.5 (440)	
		Heat	m <sup>3</sup> /min (ft <sup>3</sup> /min)	12.8 (450)	
Outdoor Airflow	Hi	Cool	m <sup>3</sup> /min (ft <sup>3</sup> /min)	33.3 (1175)	
		Heat	m <sup>3</sup> /min (ft <sup>3</sup> /min)	33.3 (1175)	
Refrigeration Cycle	Control Device			Check Valve & Capillary Tube	
	Refrigerant Oil		cm <sup>3</sup>	FV50S (450)	
	Refrigerant Type		g (oz)	R410A, 1.06k (37.4)	
Dimension	Height (I/D / O/D)		mm (inch)	290 (11-7/16) / 622 (24-1/2)	
	Width (I/D / O/D)		mm (inch)	870 (34-9/32) / 824 (32-15/32)	
	Depth (I/D / O/D)		mm (inch)	214 (8-7/16) / 299 (11-25/32)	
Weight	Net (I/D / O/D)		kg (lb)	9 (20) / 36 (79)	
	Pipe Diameter (Liquid / Gas)		mm (inch)	6.35 (1/4) / 9.52 (3/8)	
Piping	Standard length		m (ft)	5.0 (16.4)	
	Length Range (min – max)		m (ft)	3 (9.8) ~ 15 (49.2)	
	I/D & O/D Height Different		m (ft)	5.0 (16.4)	
	Additional Gas Amount		g/m (oz/ft)	20 (0.2)	
	Length for Additional Gas		m (ft)	7.5 (24.6)	
	Drain Hose	Inner Diameter		mm	16
Length		mm	650		
Indoor Heat Exchanger	Fin Material			Aluminium (Pre Coat)	
	Fin Type			Slit Fin	
	Row x Stage x FPI			2 x 15 x 21	
	Size (W x H x L)		mm	610 x 315 x 25.4	
Outdoor Heat Exchanger	Fin Material			Aluminium	
	Fin Type			Corrugated Fin	
	Row x Stage x FPI			2 x 28 x 17	
	Size (W x H x L)		mm	36.4 x 588 x 606.6	

Air Filter	Material		Polypropelene	
	Type		One-touch	
Power Supply			Indoor Power Supply	
Power Supply Cord		A	Nil	
Thermostat			Electronic Control	
Protection Device			Electronic Control	
			Dry Bulb	Wet Bulb
Indoor Operation Range	Cooling	Maximum	32	23
		Minimum	16	11
	Heating	Maximum	30	-
		Minimum	16	-
Outdoor Operation Range	Cooling	Maximum	43	26
		Minimum	16	11
	Heating	Maximum	24	18
		Minimum	-15	-16

1. Cooling capacities are based on indoor temperature of 27°C Dry Bulb (80.6°F Dry Bulb), 19.0°C Wet Bulb (66.2°F Wet Bulb) and outdoor air temperature of 35°C Dry Bulb (95°F Dry Bulb), 24°C Wet Bulb (75.2°F Wet Bulb)
2. Heating capacities are based on indoor temperature of 20°C Dry Bulb (68°F Dry Bulb) and outdoor air temperature of 7°C Dry Bulb (44.6°F Dry Bulb), 6°C Wet Bulb (42.8°F Wet Bulb)
3. Heating low temperature capacity, Input Power and COP measured at 230 V, indoor temperature 20°C, outdoor 2/1°C
4. Heating extreme low temperature capacity, Input Power and COP measured at 230 V, indoor temperature 20°C, outdoor -7/-8°C
5. Specifications are subjected to change without prior notice for further improvement.

### 3. Features

- **Inverter Technology**
  - Wider output power range
  - Energy saving
  - More precise temperature control
- **Environment Protection**
  - Non-ozone depletion substances refrigerant (R410A)
- **Long Installation Piping**
  - Long piping up to 15 meters during single split connection only
- **Easy to use remote control**
- **Quality Improvement**
  - Random auto restart after power failure for safety restart operation
  - Gas leakage protection
  - Prevent compressor reverse cycle
  - Inner protector to protect Compressor
  - Noise prevention during soft dry operation
- **Operation Improvement**
  - 24-hour timer setting
- **Serviceability Improvement**
  - Breakdown Self Diagnosis function

## 4. Location of Controls and Components

### 4.1 Indoor Unit

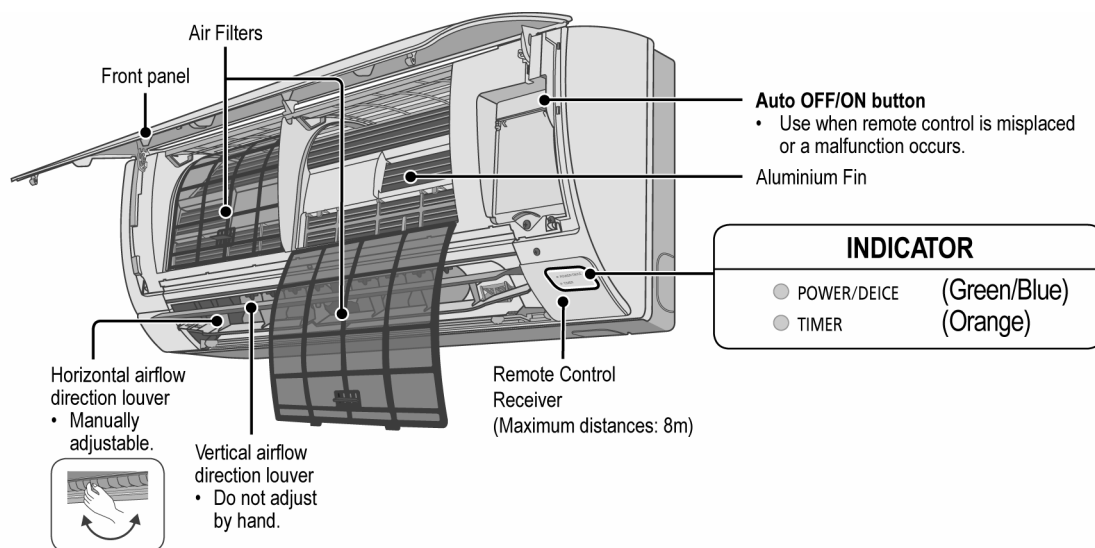

### 4.2 Outdoor Unit

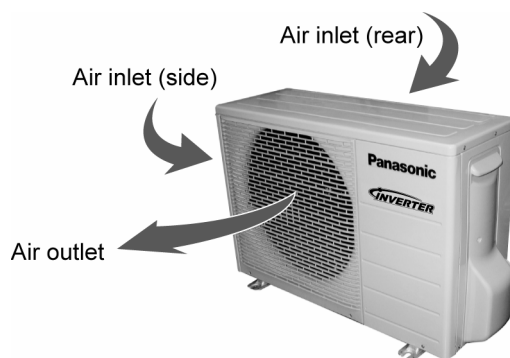

### 4.3 Remote Control

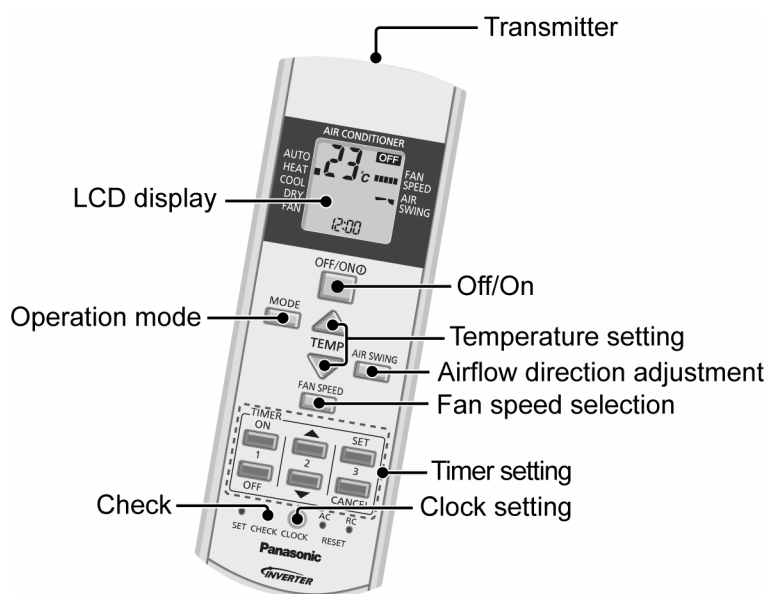



# 5. Dimensions

## 5.1 Indoor Unit

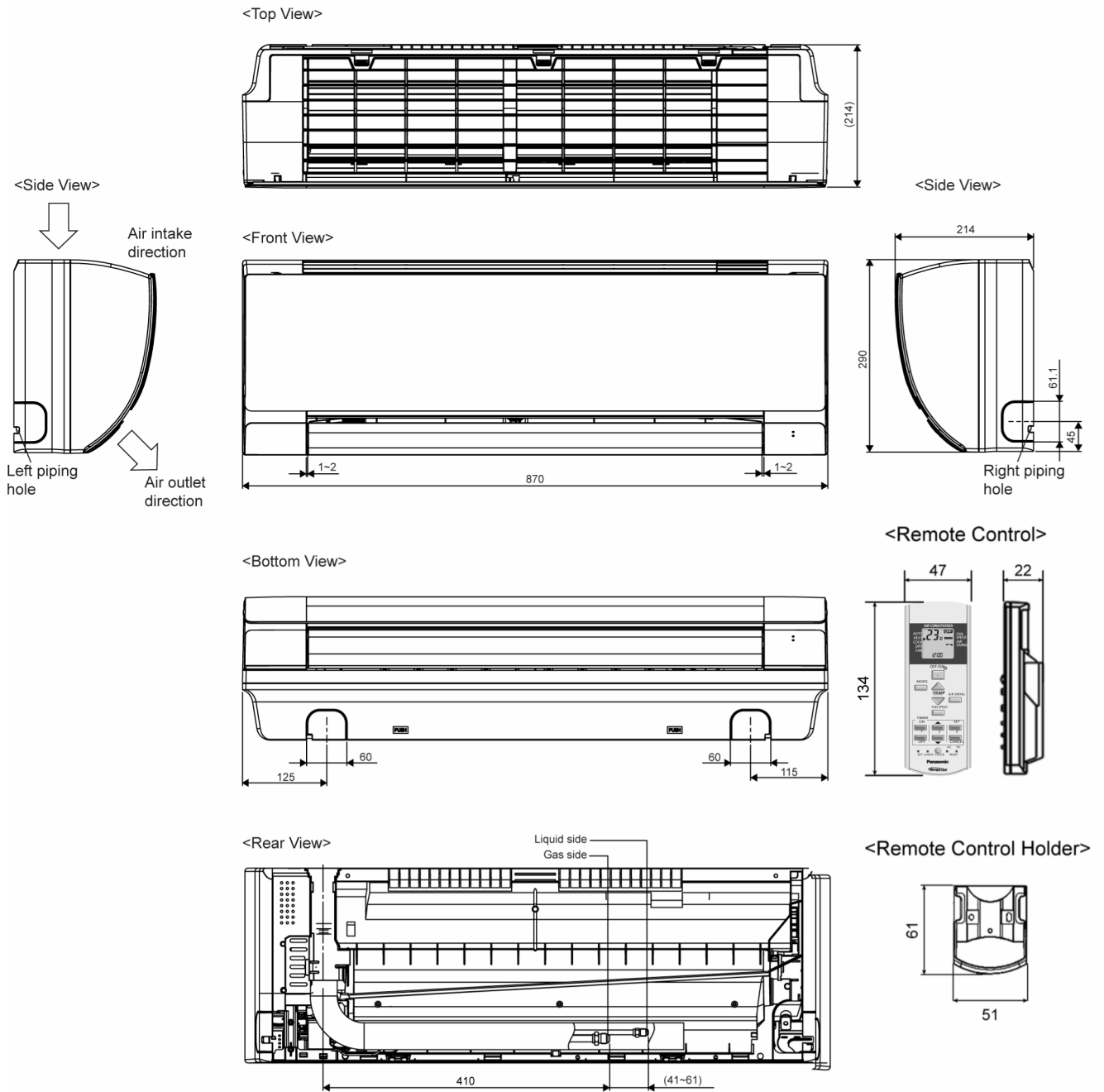

Relative position between the indoor unit and the installation plate <Front View>

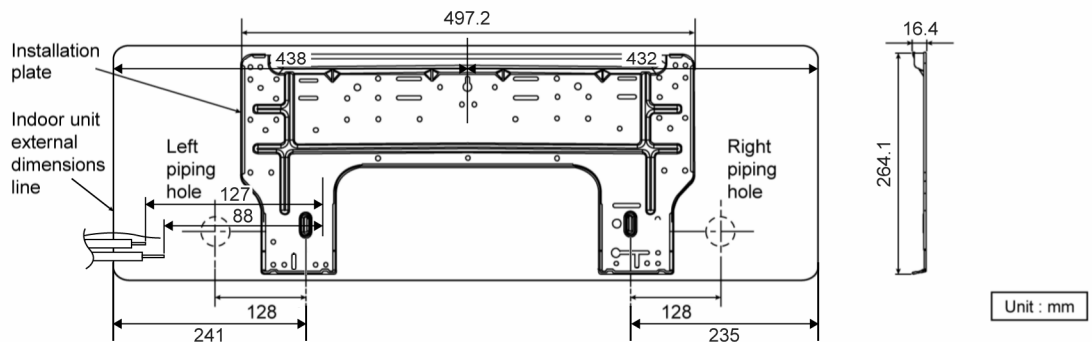

## 5.2 Outdoor Unit

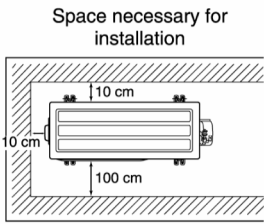

Anchor Bolt Pitch  
330 x 540

<Side View>

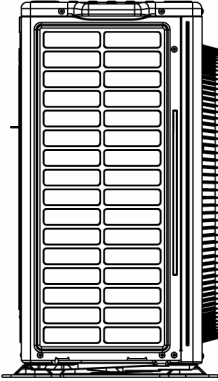

Unit: mm

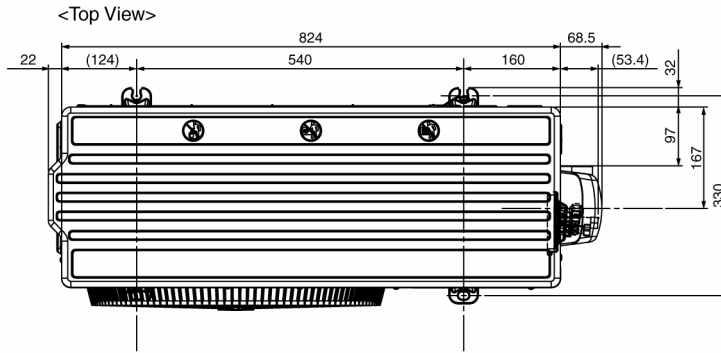

<Front View>

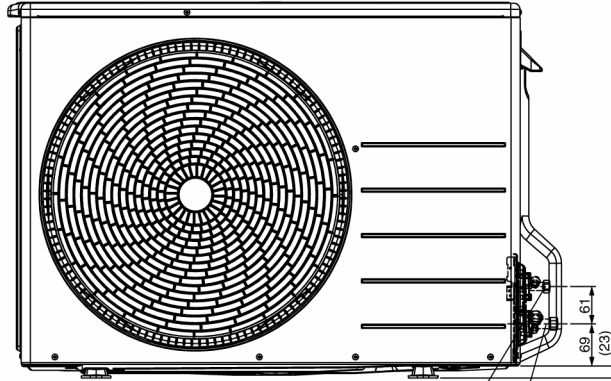

3-way valve at Gas side  
(Low Pressure)  
2-way valve at Liquid side  
(High Pressure)

<Side View>

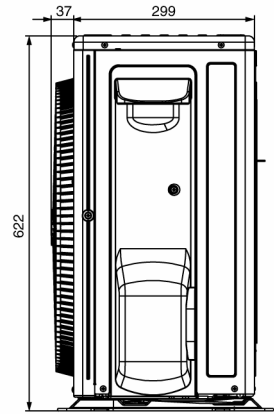

# 6. Refrigeration Cycle Diagram

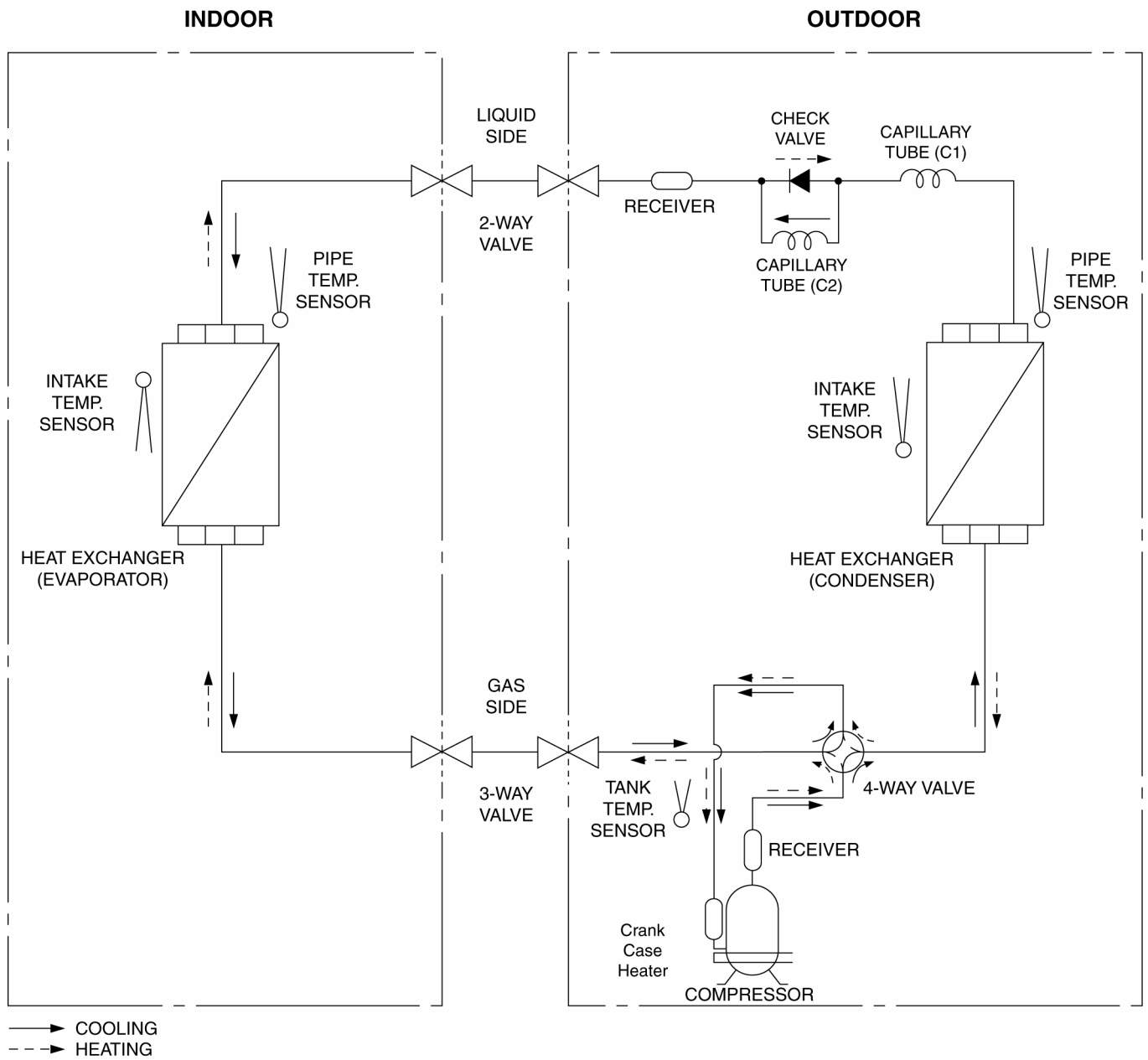

# 7. Block Diagram

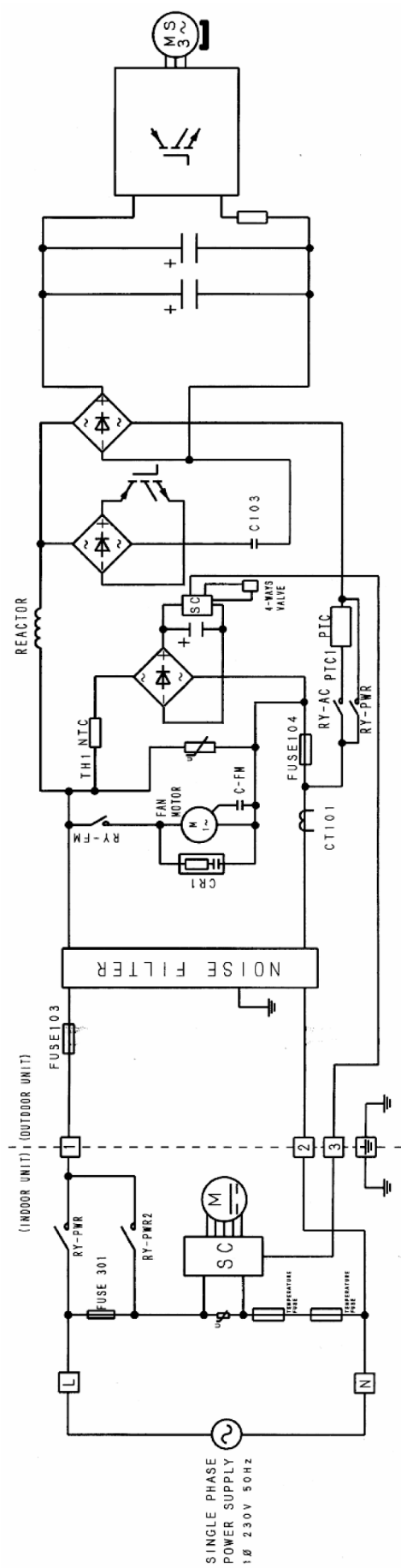

# 8. Wiring Connection Diagram

## 8.1 Indoor Unit

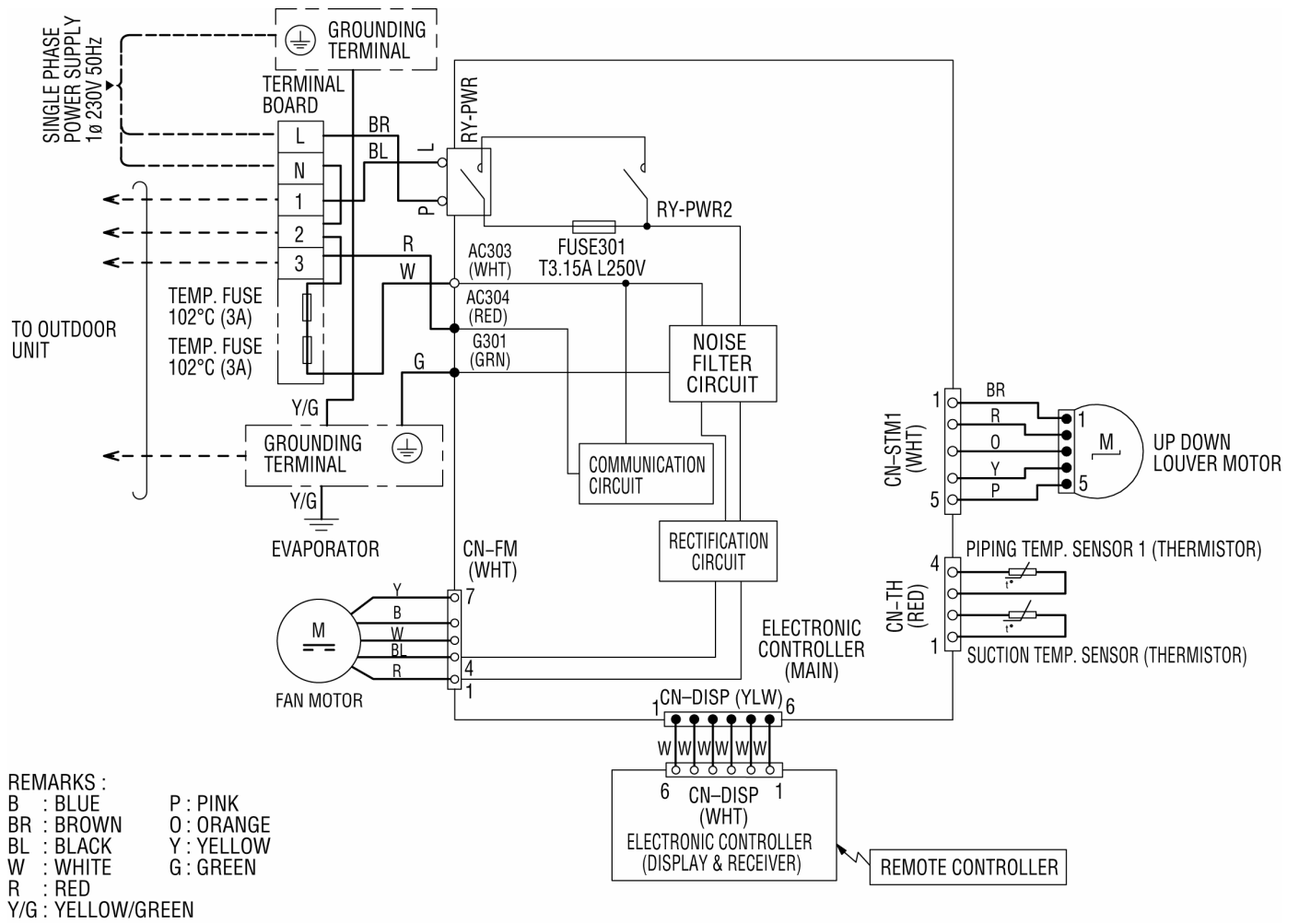

## 8.2 Outdoor Unit

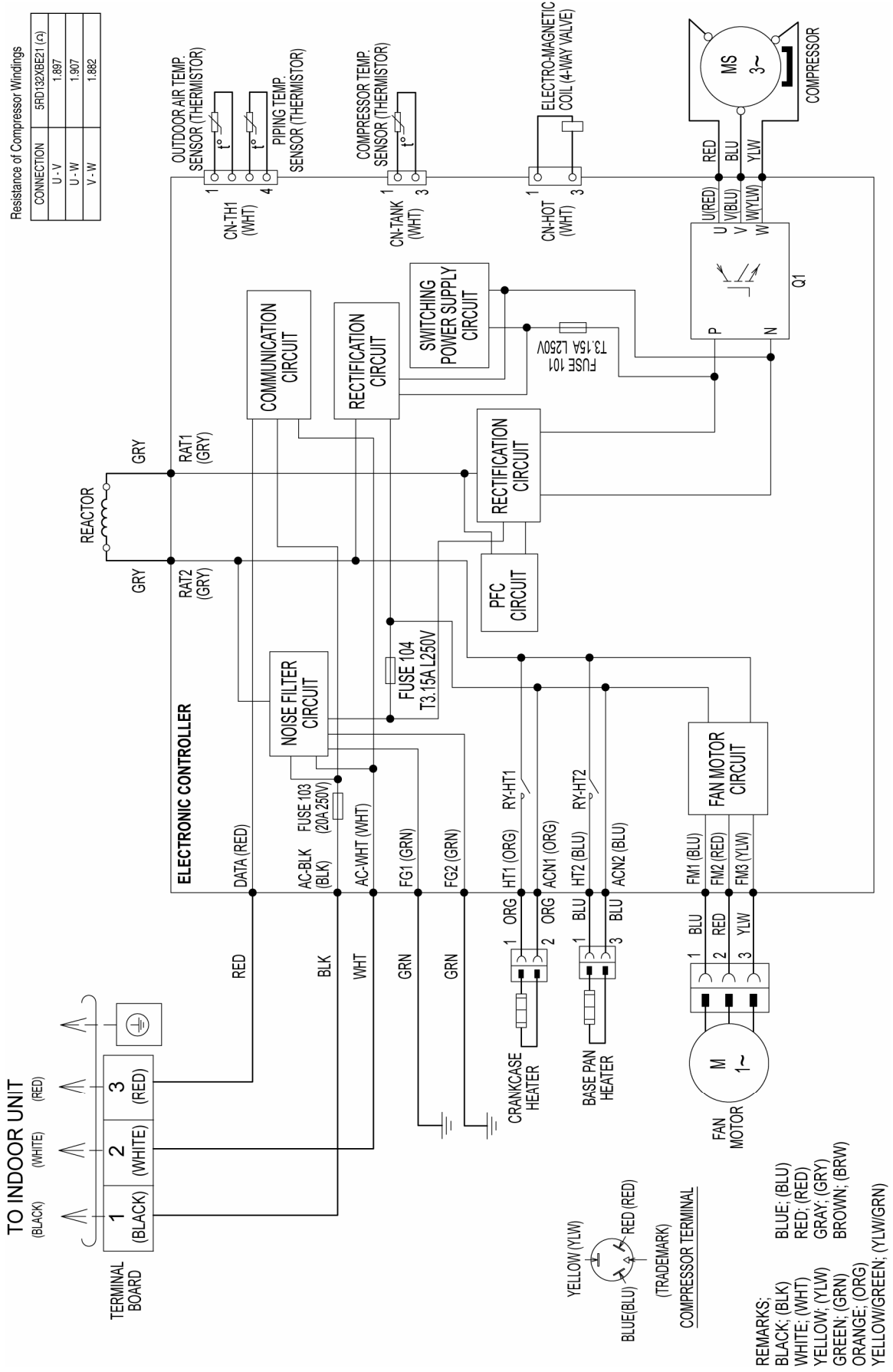

# 9. Electronic Circuit Diagram

## 9.1 Indoor Unit

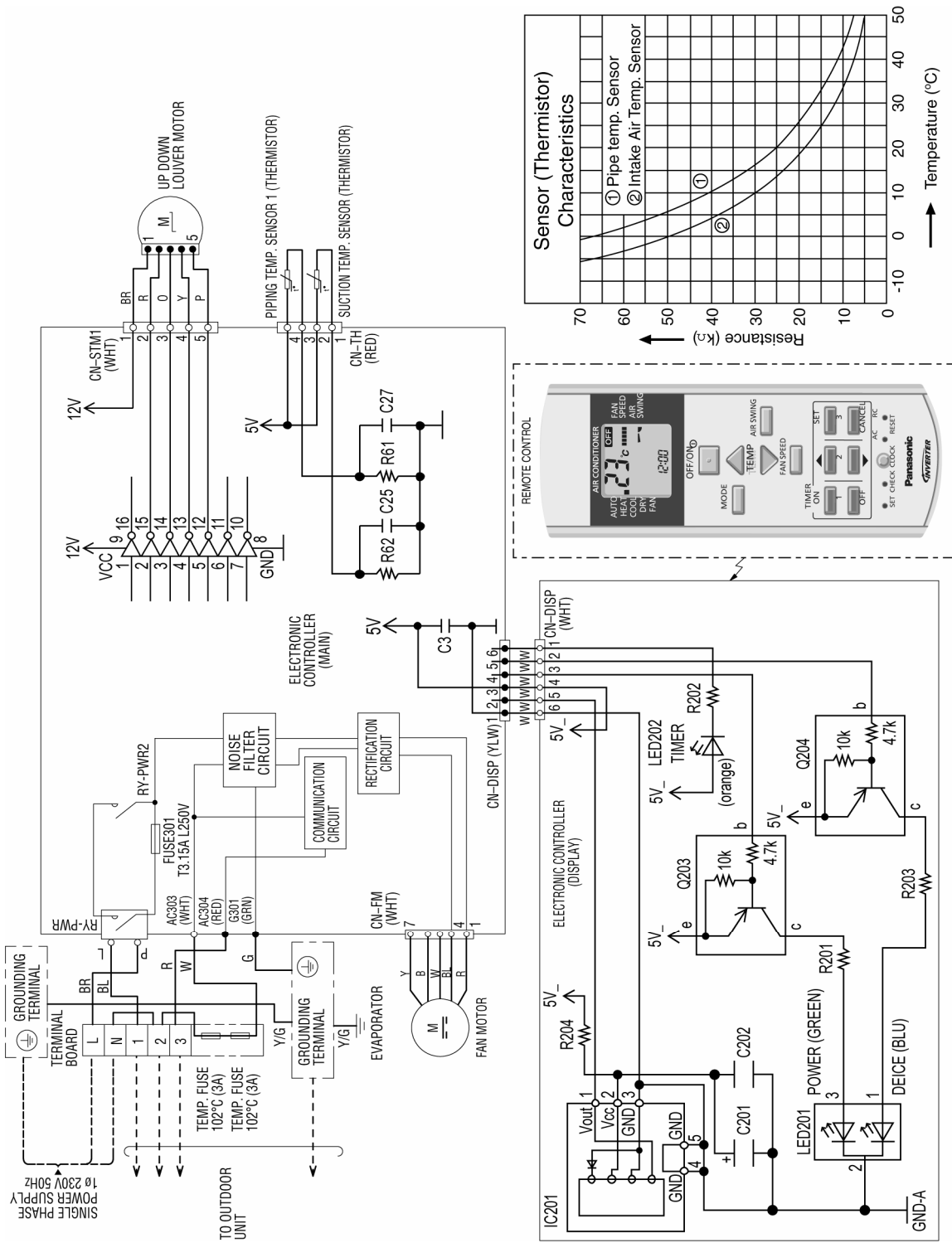

## 9.2 Outdoor Unit

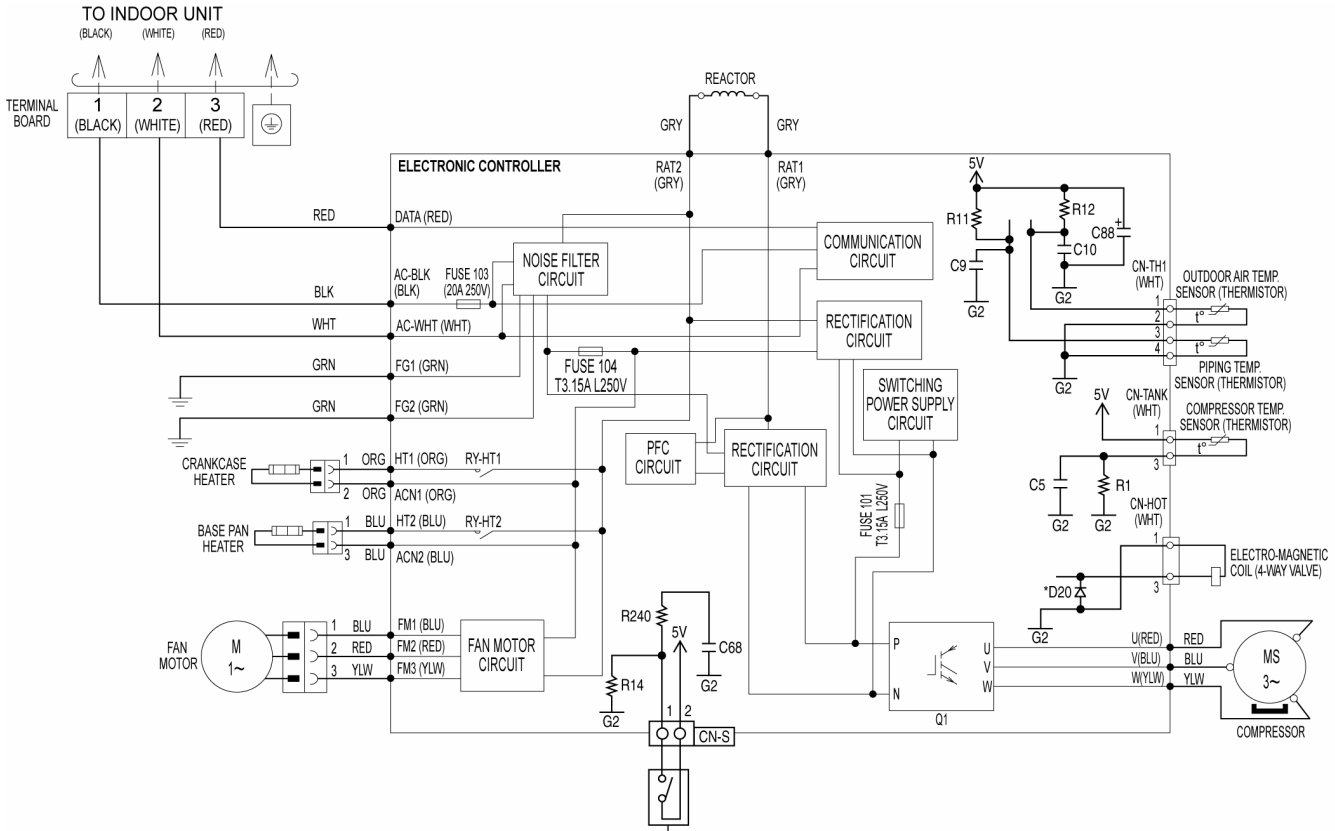

- The unit turn to the Rated Frequency Cooling Operation by short-circuiting CN-S after applying power between the terminal 1 and 2.
- Operation of the compressor and the outdoor fan motor can be checked by applying power after short-circuiting CN-S.

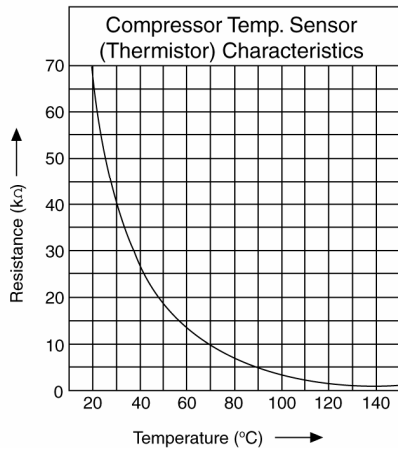
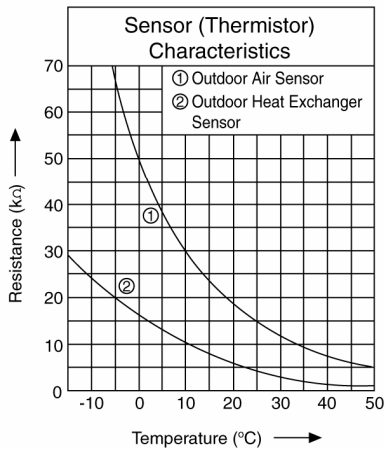



# 10. Printed Circuit Board

## 10.1 Indoor Unit

### 10.1.1 Main Printed Circuit Board

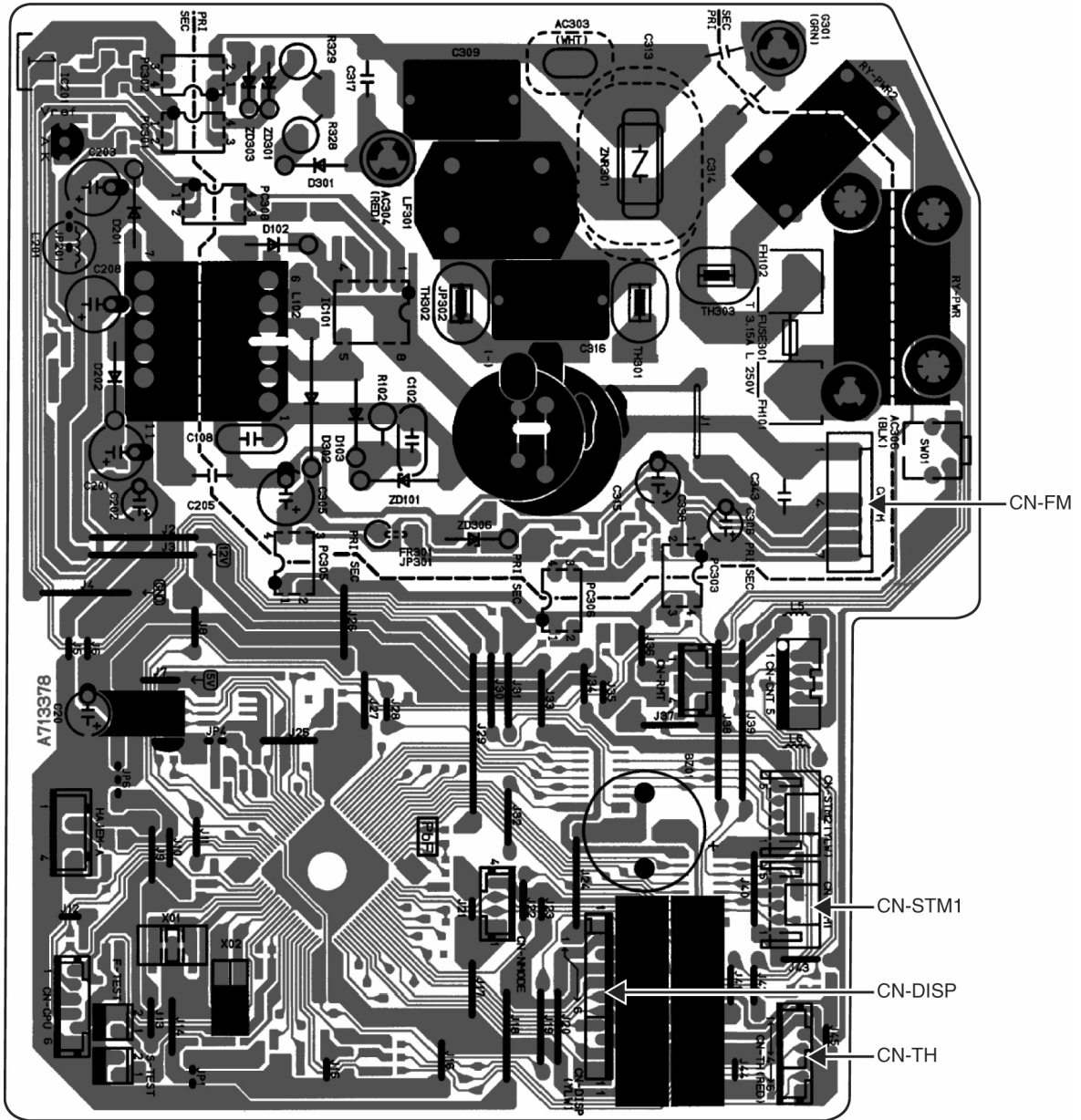

### 10.1.2 Indicator and Receiver Printed Circuit Board

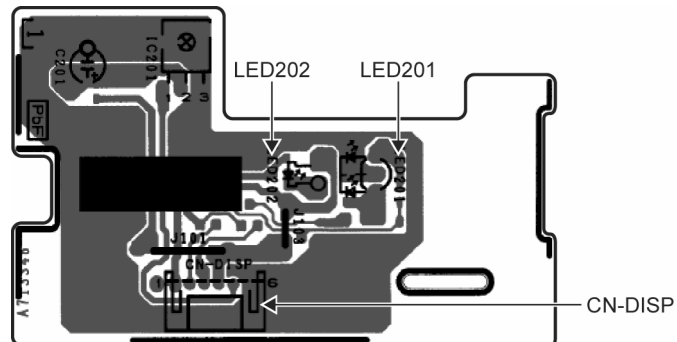

# 10.2 Outdoor Unit

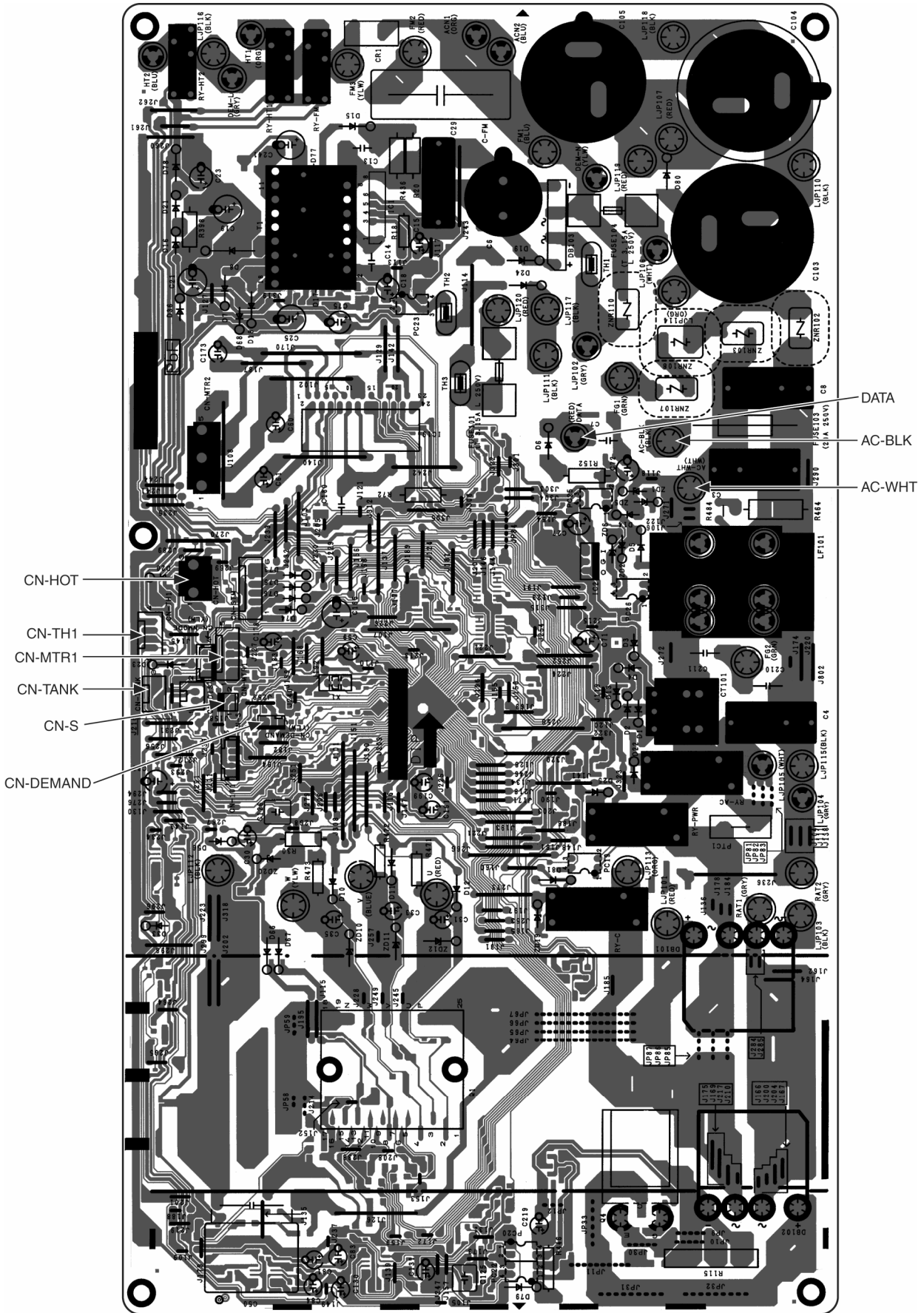

# 11. Installation Instruction

## 11.1 Select the Best Location

### 11.1.1 Indoor Unit

- Do not install the unit in excessive oil fume area such as kitchen, workshop and etc.
- There should not be any heat source or steam near the unit.
- There should not be any obstacles blocking the air circulation.
- A place where air circulation in the room is good.
- A place where drainage can be easily done.
- A place where noise prevention is taken into consideration.
- Do not install the unit near the door way.
- Ensure the spaces indicated by arrows from the wall, ceiling, fence or other obstacles.
- Recommended installation height for indoor unit shall be at least 2.5 m.

### 11.1.2 Outdoor Unit

- If an awning is built over the unit to prevent direct sunlight or rain, be careful that heat radiation from the condenser is not obstructed.
- There should not be any animal or plant which could be affected by hot air discharged.
- Keep the spaces indicated by arrows from wall, ceiling, fence or other obstacles.
- Do not place any obstacles which may cause a short circuit of the discharged air.
- If piping length is over the [piping length for additional gas], additional refrigerant should be added as shown in the table.

Model	Horse Power (HP)	Piping size		Std. Length (m)	Max. Elevation (m)	Min. Piping Length (m)	Max. Piping Length (m)	Additional Refrigerant (g/m)	Piping Length for add. gas (m)
		Gas	Liquid						
CE9***	1.0HP	9.52 mm	6.35 mm	5	5	3	15	20	7.5
CE12***	1.5HP	(3/8")	(1/4")		5	3	15	20	7.5

Example: For CE9\*\*\*

If the unit is installed at 10 m distance, the quantity of additional refrigerant should be 50 g ....  $(10 - 7.5) \text{ m} \times 20 \text{ g/m} = 50 \text{ g}$ .

### 11.1.3 Indoor/Outdoor Unit Installation Diagram

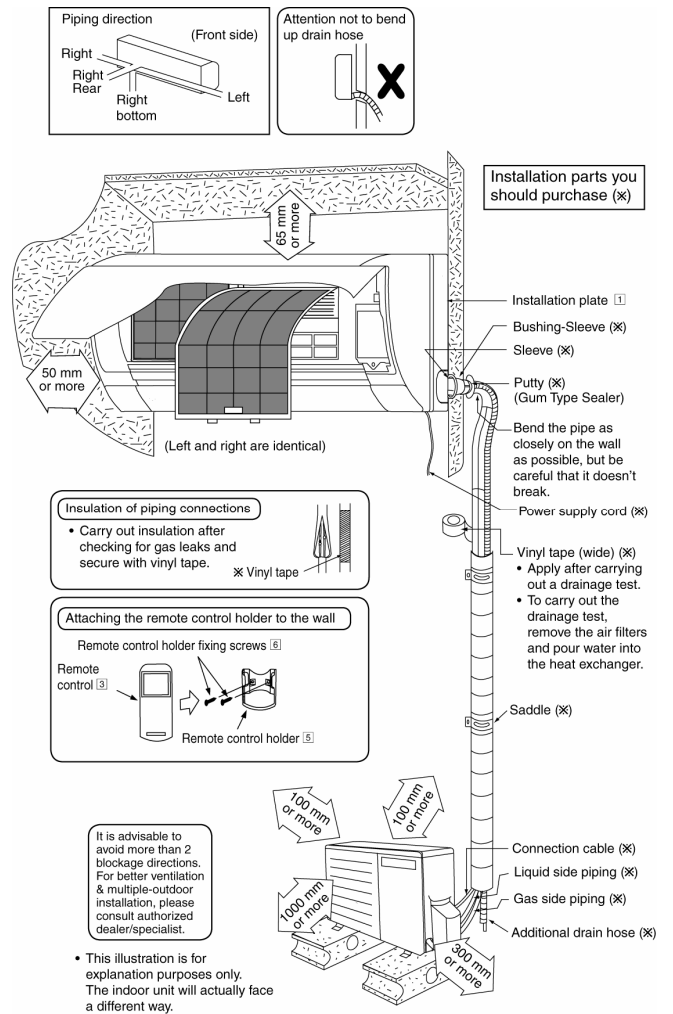

## 11.2 Indoor Unit

### 11.2.1 How to Fix Installation Plate

The mounting wall is strong and solid enough to prevent it from the vibration.

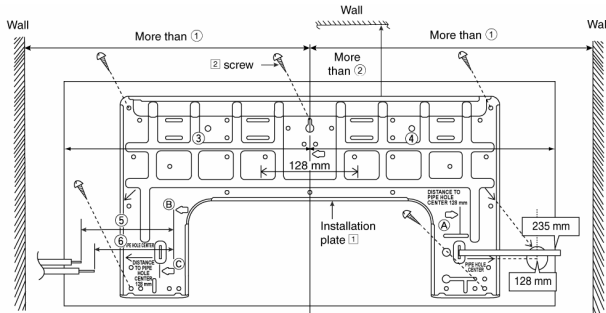

Model	Dimension					
	①	②	③	④	⑤	⑥
CE9***, CE12***	490 mm	86 mm	438 mm	432 mm	127 mm	88 mm

The center of installation plate should be at more than ① at right and left of the wall.

The distance from installation plate edge to ceiling should more than ②.

From installation plate center to unit's left side is ③.

From installation plate center to unit's right side is ④.

- Ⓑ : For left side piping, piping connection for liquid should be about ⑤ from this line.  
 : For left side piping, piping connection for gas should be about ⑥ from this line.

- Mount the installation plate on the wall with 5 screws or more (at least 5 screws). (If mounting the unit on the concrete wall, consider using anchor bolts.)
  - Always mount the installation plate horizontally by aligning the marking-off line with the thread and using a level gauge.
- Drill the piping plate hole with  $\varnothing 70$  mm hole-core drill.
  - Line according to the left and right side of the installation plate. The meeting point of the extended line is the center of the hole. Another method is by putting measuring tape at position as shown in the diagram above. The hole center is obtained by measuring the distance namely 128 mm for left and right hole respectively.
  - Drill the piping hole at either the right or the left and the hole should be slightly slanting to the outdoor side.

### 11.2.2 To Drill a Hole in the Wall and Install a Sleeve of Piping

- Insert the piping sleeve to the hole.
- Fix the bushing to the sleeve.
- Cut the sleeve until it extrudes about 15 mm from the wall.

#### ⚠ CAUTION

⚠ When the wall is hollow, please be sure to use the sleeve for tube assembly to prevent dangers caused by mice biting the connection cable.

- Finish by sealing the sleeve with putty or caulking compound at the final stage.

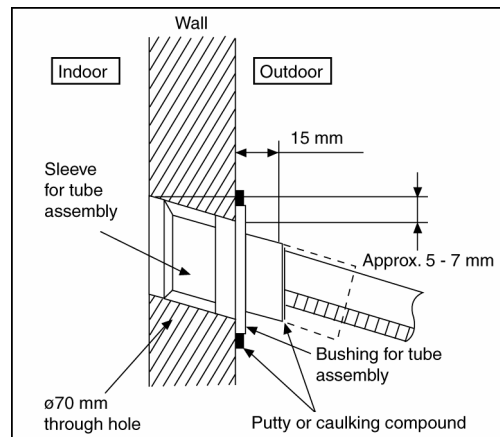

### 11.2.3 Indoor Unit Installation

- Do not turn over the unit without its shock absorber during pull out the piping. It may cause intake grille damage.
- Use shock absorber during pull out the piping to protect the intake grille from damage.

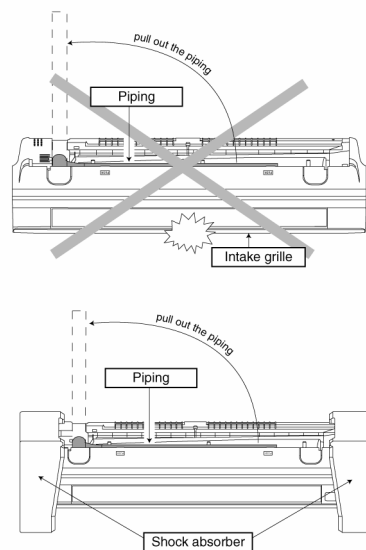

### 11.2.3.1 For the right rear piping

- Step-1** Pull out the Indoor piping
- Step-2** Install the Indoor Unit
- Step-3** Secure the Indoor Unit
- Step-4** Insert the connection cable

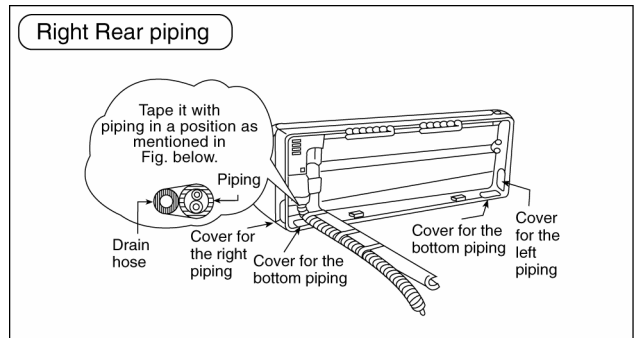

### 11.2.3.2 For the right and right bottom piping

- Step-1** Pull out the Indoor piping
- Step-2** Install the Indoor Unit
- Step-3** Insert the connection cable
- Step-4** Secure the Indoor Unit

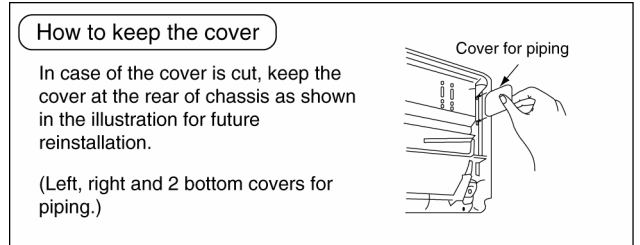

### 11.2.3.3 For the embedded piping

- Step-1** Replace the drain hose
- Step-2** Bend the embedded piping
  - Use a spring bender or equivalent to bend the piping so that the piping is not crushed.
- Step-3** Pull the connection cable into Indoor Unit
  - The inside and outside connection cable can be connected without removing the front grille.
- Step-4** Cut and flare the embedded piping
  - When determining the dimensions of the piping, slide the unit all the way to the left on the installation plate.
  - Refer to the section "Cutting and flaring the piping".
- Step-5** Install the Indoor Unit
- Step-6** Connect the piping
  - Please refer to "Connecting the piping" column in outdoor unit section. (Below steps are done after connecting the outdoor piping and gas-leakage confirmation.)
- Step-7** Insulate and finish the piping
  - Please refer to "Insulation of piping connection" column as mentioned in indoor/outdoor unit installation.
- Step-8** Secure the Indoor Unit

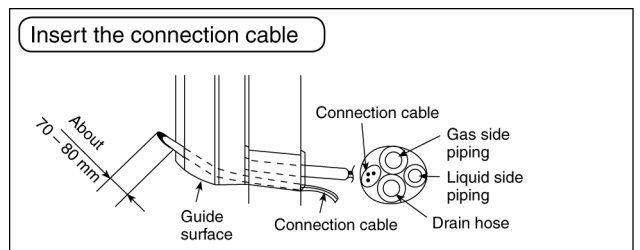
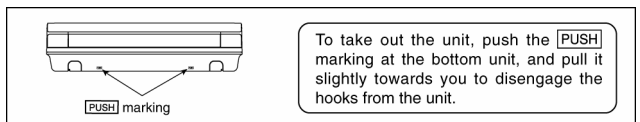
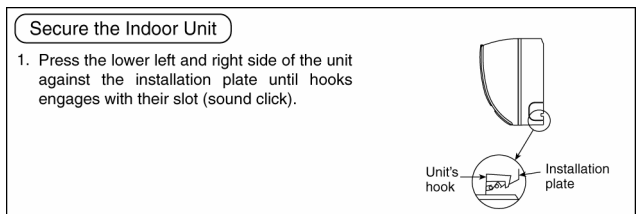
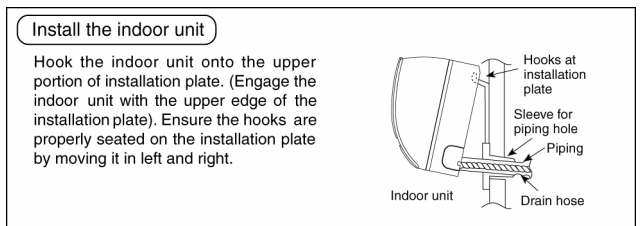
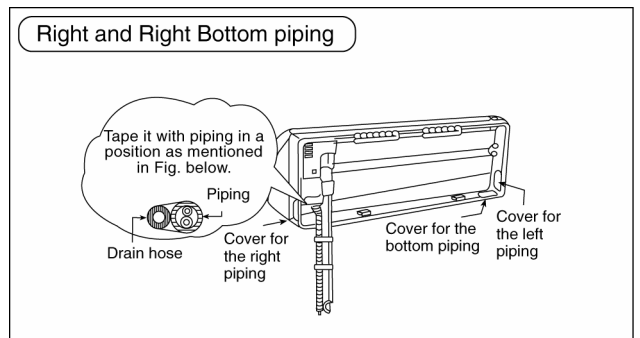

(This can be used for left rear piping and bottom piping also.)

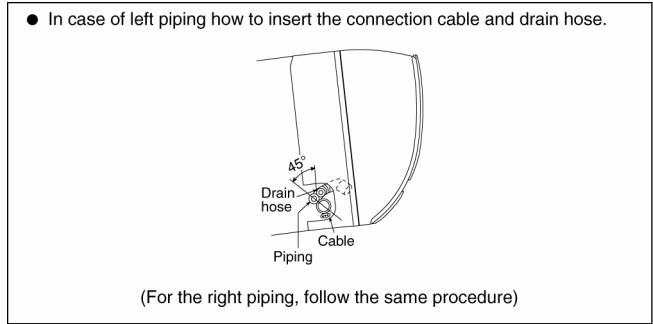
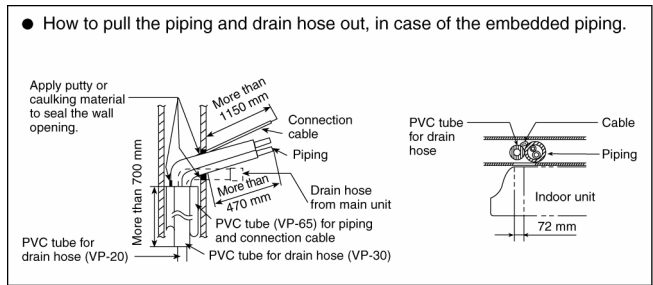
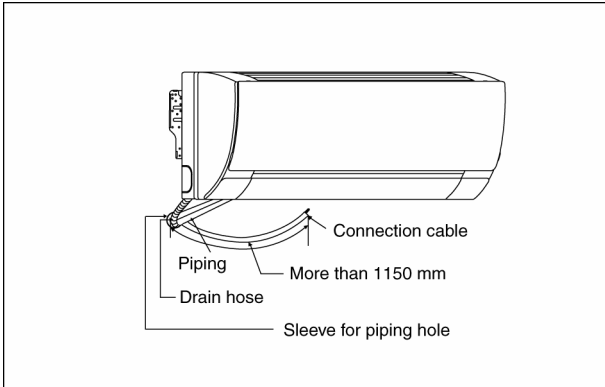
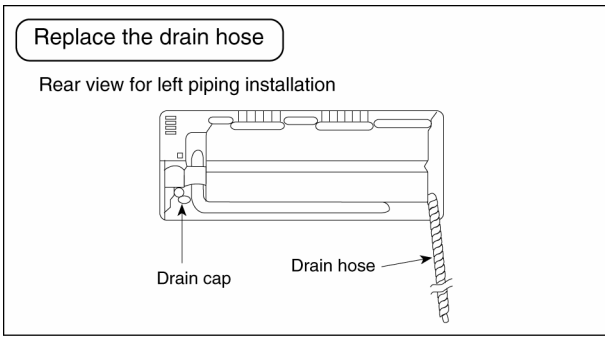

### 11.2.4 Connect the Cable to the Indoor Unit

The power supply cord, indoor and outdoor unit connection cable can be connected without removing the front grille.

- 1 Install the indoor unit on the installing holder that mounted on the wall.
- 2 Open the front panel and grille door by loosening the screw.
- 3 Cable connection to the power supply through Isolating Devices (Disconnecting means).
  - Connect the approved polychloroprene sheathed **power supply cord** 3 x 1.5 mm<sup>2</sup>, type designation 245 IEC 57 or heavier cord to the terminal board, and connect the other end of the cable to Isolating Devices (Disconnecting means).
  - Do not use joint power supply cord. Replace the wire if the existing wire (from concealed wiring, or otherwise) is too short.
  - In unavoidable case, joining of power supply cord between isolating devices and terminal board of air conditioner shall be done by using approved socket and plug with earth pin rated 15/16A. Wiring work to both socket and plug must follow to national wiring standard.
- 4 Bind all the power supply cord lead wire with tape and route the power supply cord via the left escapement.
- 5 **Connection cable** between indoor unit and outdoor unit shall be approved polychloroprene sheathed 4 x 1.5 mm<sup>2</sup> flexible cord, type designation 245 IEC 57 or heavier cord. Do not use joint connection cable. Replace the wire if the existing wire (from concealed wiring, or otherwise) is too short.
- 6 Bind all the indoor and outdoor connection cable with tape and route the connection cable via the right escapement.
- 7 Remove the tapes and connect the power supply cord and connection cable between indoor unit and outdoor unit according to the diagram below.

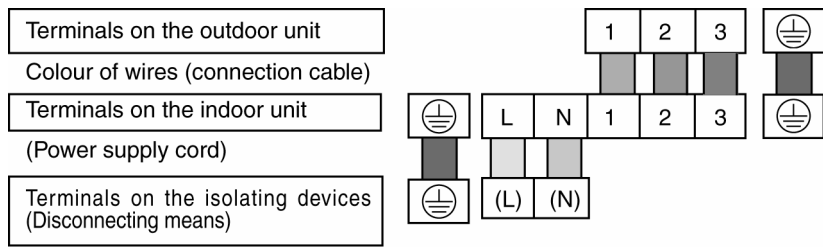

- 8 Secure the power supply cord and connection cable onto the control board with the holder.
- 9 Close grille door by tighten with screw and close the front panel.

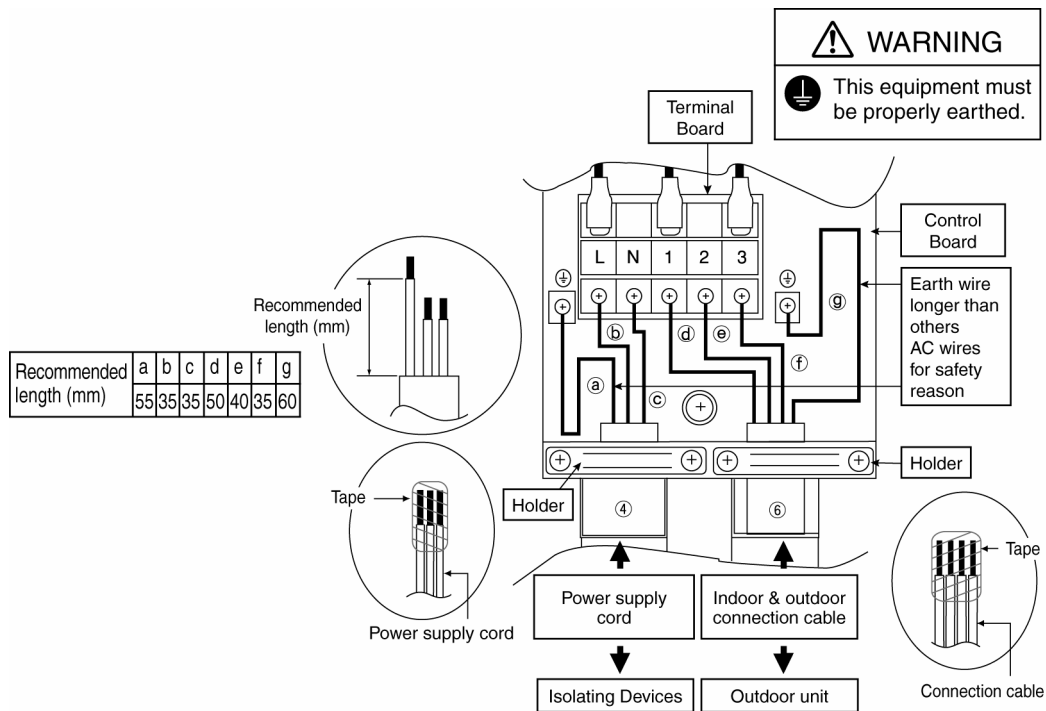

**Note:**

- Isolating Devices (Disconnecting means) should have minimum 3.0 mm contact gap.
- Ensure the colour of wires of outdoor unit and the terminal Nos. are the same to the indoor's respectively.
- Earth wire shall be Yellow/Green (Y/G) in colour and longer than other AC wires as shown in the figure for the electrical safety in case of the slipping out of the cord from the anchorage.

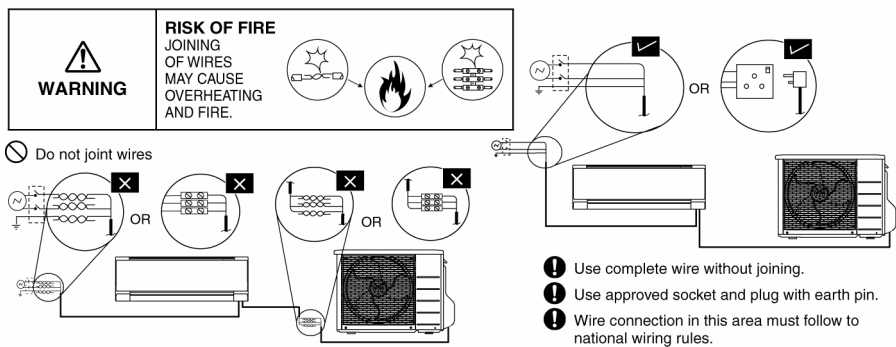
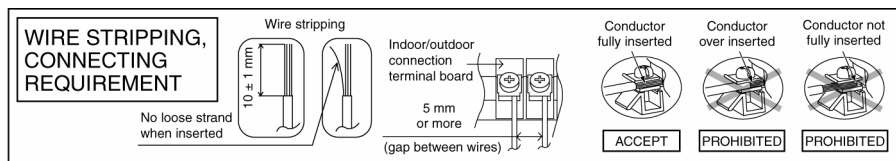

## 11.3 Outdoor Unit

### 11.3.1 Install the Outdoor Unit

- After selecting the best location, start installation according to Indoor/Outdoor Unit Installation Diagram.
  - Fix the unit on concrete or rigid frame firmly and horizontally by bolt nut ( $\varnothing 10$  mm).
  - When installing at roof, please consider strong wind and earthquake. Please fasten the installation stand firmly with bolt or nails.

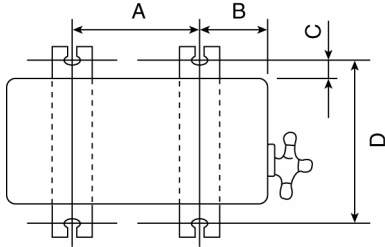

Model	A	B	C	D
CE9***, CE12***	540 mm	160 mm	18.5 mm	330 mm

### 11.3.2 Connect the Piping

#### Connecting the Piping to Indoor

Please make flare after inserting flare nut (locate at joint portion, of tube assembly) onto the copper pipe. (In case of using long piping)

Connect the piping

- Align the center of piping and sufficiently tighten the flare nut with fingers.
- Further tighten the flare nut with torque wrench in specified torque as stated in the table.

Do not over tighten, over tightening may cause gas leakage.	
Piping Size	Torque
6.35 mm (1/4")	[18 N•m (1.8 kgf.m)]
9.52 mm (3/8")	[42 N•m (4.3 kgf.m)]
12.7 mm (1/2")	[55 N•m (5.6 kgf.m)]
15.88 mm (5/8")	[65 N•m (6.6 kgf.m)]
19.05 mm (3/4")	[100 N•m (10.2 kgf.m)]

#### Connecting the Piping to Outdoor

Decide piping length and then cut by using pipe cutter. Remove burrs from cut edge.

Make flare after inserting the flare nut (locate at valve) onto the copper pipe.

Align center of piping to valves and then tighten with torque wrench to the specified torque as stated in the table.

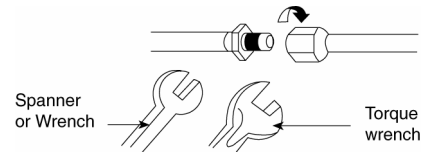

### 11.3.3 Evacuation of the Equipment

WHEN INSTALLING AN AIR CONDITIONER, BE SURE TO EVACUATE THE AIR INSIDE THE INDOOR UNIT AND PIPES in the following procedure.

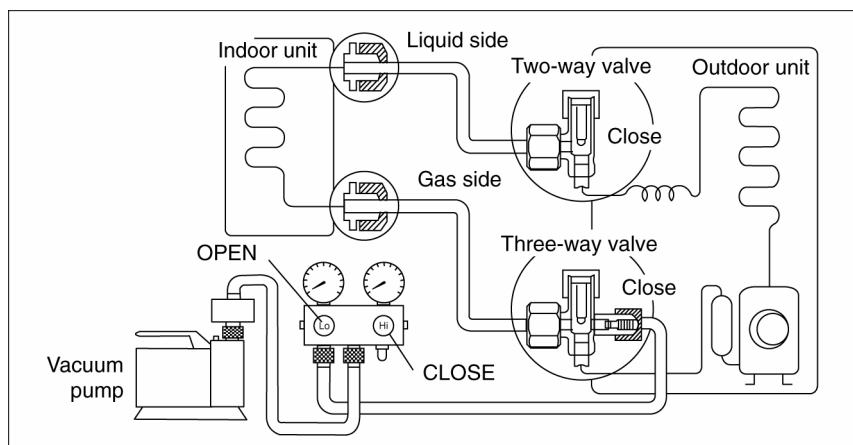

- Connect a charging hose with a push pin to the Low side of a charging set and the service port of the 3-way valve.
  - Be sure to connect the end of the charging hose with the push pin to the service port.
- Connect the center hose of the charging set to a vacuum pump.









- 3 Turn on the power switch of the vacuum pump and make sure that the needle in the gauge moves from 0 cmHg (0 MPa) to -76 cmHg (-0.1 MPa). Then evacuate the air approximately ten minutes.
- 4 Close the Low side valve of the charging set and turn off the vacuum pump. Make sure that the needle in the gauge does not move after approximately five minutes.  
Note: BE SURE TO TAKE THIS PROCEDURE IN ORDER TO AVOID REFRIGERENT GAS LEAKAGE.
- 5 Disconnect the charging hose from the vacuum pump and from the service port of the 3-way valve.
- 6 Tighten the service port caps of the 3-way valve at a torque of 18 N•m with a torque wrench.
- 7 Remove the valve caps of both of the 2-way valve and 3-way valve. Position both of the valves to "OPEN" using a hexagonal wrench (4 mm).
- 8 Mount valve caps onto the 2-way valve and the 3-way valve.
  - Be sure to check for gas leakage.

- If gauge needle does not move from 0 cmHg (0 MPa) to -76 cmHg (-0.1 MPa), in the step ③ above take the following measure:
  - If the leak stops when the piping connections are tightened further, continue working from step ③.
  - If the leak does not stop when the connections are retightened, repair location of leak.
  - Do not release refrigerant during piping work for installation and reinstallation.
  - Take care of the liquid refrigerant, it may cause frostbite.

### 11.3.4 Connect the cable to the Outdoor Unit

- 1 Remove the control board cover from the unit by loosening the screw.
- 2 **Connection cable** between indoor unit and outdoor unit shall be approved polychloroprene sheathed 4 x 1.5 mm<sup>2</sup> flexible cord, type designation 245 IEC 57 or heavier cord. Do not use joint connection cable. Replace the wire if the existing wire (from concealed wiring, or otherwise) is too short.

Terminals on the outdoor unit	1	2	3	
Colour of wires				
Terminals on the indoor unit	1	2	3	

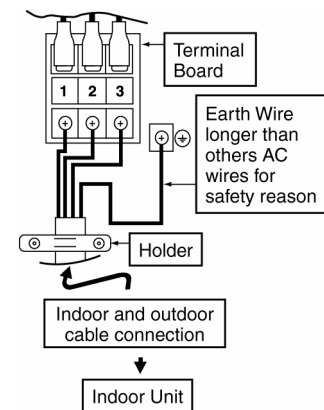

- 3 Secure the cable onto the control board with the holder (clammer).
- 4 Attach the control board cover back to the original position with screw.
- 5 For wire stripping and connection requirement, refer to instruction 11.2.4 of indoor unit.

**⚠ WARNING**

⚡ This equipment must be properly earthed.

- Earth wire shall be Yellow/Green (Y/G) in colour and longer than the other AC wires for safety reason.

### 11.3.5 Piping Insulation

- 1 Please carry out insulation at pipe connection portion as mentioned in Indoor/Outdoor Unit Installation Diagram. Please wrap the insulated piping end to prevent water from going inside the piping.
- 2 If drain hose or connecting piping is in the room (where dew may form), please increase the insulation by using POLY-E FOAM with thickness 6 mm or above.

#### 11.3.5.1 Cutting and flaring the piping

- 1 Please cut using pipe cutter and then remove the burrs.
- 2 Remove the burrs by using reamer. If burrs are not removed, gas leakage may be caused. Turn the piping end down to avoid the metal powder entering the pipe.
- 3 Please make flare after inserting the flare nut onto the copper pipes.

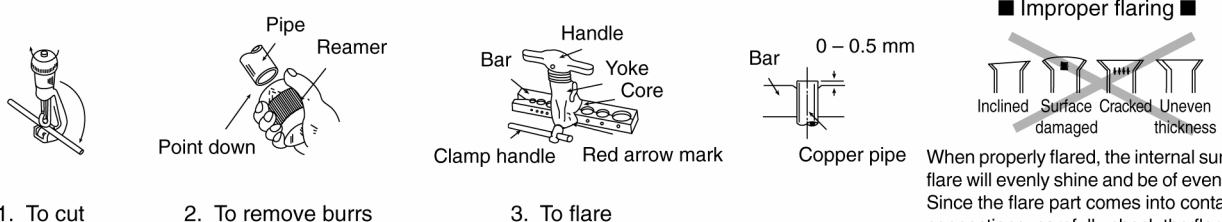

1. To cut

2. To remove burrs

3. To flare

When properly flared, the internal surface of the flare will evenly shine and be of even thickness. Since the flare part comes into contact with the connections, carefully check the flare finish.

## 12. Operation and Control

### 12.1 Basic Function

Inverter control, which equipped with a microcomputer in determining the most suitable operating mode as time passes, automatically adjusts output power for maximum comfort always. In order to achieve the suitable operating mode, the microcomputer maintains the set temperature by measuring the temperature of the environment and performing temperature shifting. The compressor at outdoor unit is operating following the frequency instructed by the microcomputer at indoor unit that judging the condition according to internal setting temperature and intake air temperature.

#### 12.1.1 Internal Setting Temperature

Once the operation starts, remote control setting temperature will be taken as base value for temperature shifting processes. These shifting processes are depending on the air conditioner settings and the operation environment. The final shifted value will be used as internal setting temperature and it is updated continuously whenever the electrical power is supplied to the unit.

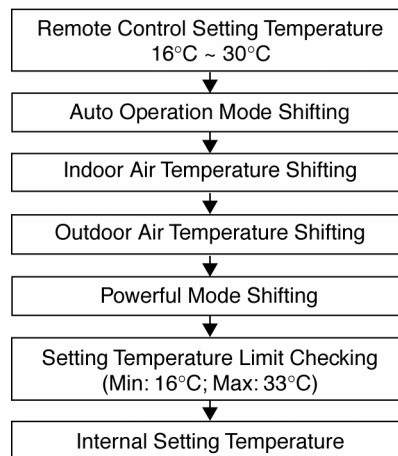

#### 12.1.2 Cooling Operation

##### 12.1.2.1 Thermostat control

- Compressor is OFF when Intake Air Temperature - Internal Setting Temperature < -1.5°C continue for 3 minutes.
- Compressor is ON after waiting for 3 minutes, if the Intake Air Temperature - Internal Setting Temperature > Compressor OFF point.

#### 12.1.3 Soft Dry Operation

##### 12.1.3.1 Thermostat control

- Compressor is OFF when Intake Air Temperature - Internal Setting Temperature < -2.0°C continue for 3 minutes.
- Compressor is ON after waiting for 3 minutes, if the Intake Air Temperature - Internal Setting Temperature > Compressor OFF point.

#### 12.1.4 Heating Operation

##### 12.1.4.1 Thermostat control

- Compressor is OFF when Intake Air Temperature - Internal Setting Temperature > +2.0°C continue for 3 minutes.
- Compressor is ON after waiting for 3 minutes, if the Intake Air Temperature - Internal Setting Temperature < Compressor OFF point.

### 12.1.5 Automatic Operation

- This mode can be set using remote control and the operation is decided by remote control setting temperature, remote control operation mode and indoor intake air temperature.
- During operation mode judgment, indoor fan motor (with speed of Lo-) is running for 30 seconds to detect the indoor intake air temperature.
- Every 10 minutes, the indoor temperature is judged.
- For the 1st judgment
  - If indoor intake temperature - remote control setting temperature  $\geq 2^{\circ}\text{C}$ , COOL mode is decided.
  - If  $-2^{\circ}\text{C} \leq$  indoor intake temperature - remote control setting temperature  $< 2^{\circ}\text{C}$ , DRY mode is decided.
  - If indoor intake temperature - remote control setting temperature  $< -2^{\circ}\text{C}$ , HEAT mode is decided.

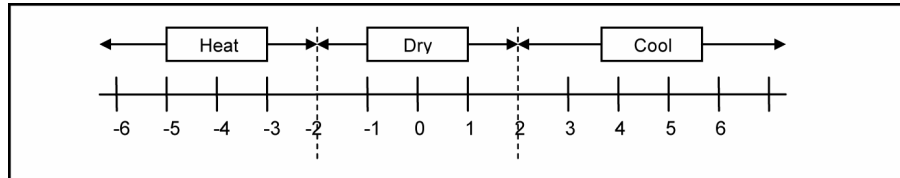

- For the 2nd judgment onwards
  - If indoor intake temperature - remote control setting temperature  $\geq 3^{\circ}\text{C}$ , if previous operate in DRY mode, then continue in DRY mode. otherwise COOL mode is decided.
  - If  $-2^{\circ}\text{C} \leq$  indoor intake temperature - remote control setting temperature  $< 3^{\circ}\text{C}$ , maintain with previous mode.
  - If indoor intake temperature - remote control setting temperature  $< -2^{\circ}\text{C}$ , HEAT mode is decided.

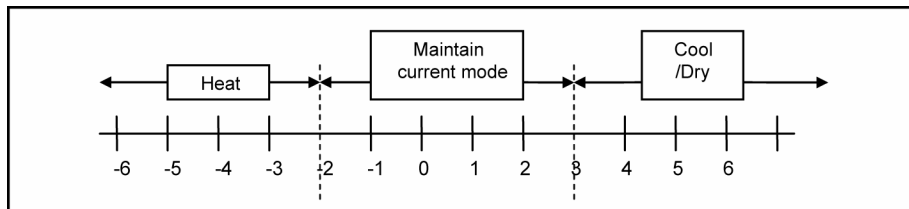

### 12.1.6 Fan Operation

- Fan Operation is used to circulate air in a room.
- During operation, indoor fan run continuously but outdoor fan and compressor stop.
- Temperature setting is not applicable.

## 12.2 Indoor Fan Motor Operation

### A. Basic Rotation Speed (rpm)

#### i. Manual Fan Speed

[Cooling, Dry, Fan]

- Fan motor's number of rotation is determined according to remote control setting.

Remote control	O	O	O	O	O
Tab	Hi	Me+	Me	Me-	Lo

[Heating]

- Fan motor's number of rotation is determined according to remote control setting.

Remote control	O	O	O	O	O
Tab	SHi	Me+	Me	Me-	Lo

ii. Auto Fan Speed

[Cooling, Dry]

- According to room temperature and setting temperature, indoor fan speed is determined automatically.
- The indoor fan will operate according to pattern below.

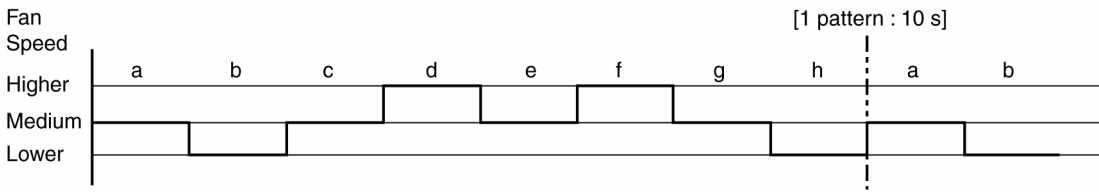

[Fan]

- Indoor fan speed is fixed at predetermined speed.

[Heating]

- According to indoor pipe temperature, automatic heating fan speed is determined as follows.

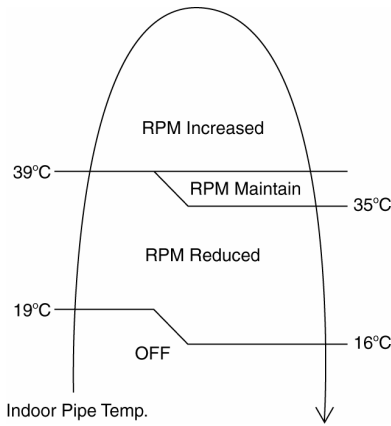

**B. Feedback control**

- Immediately after the fan motor started, feedback control is performed once every second.
- During fan motor on, if fan motor feedback  $\geq 2550$  rpm or  $< 50$  rpm continue for 10 seconds, then fan motor error counter increase, fan motor is then stop and restart. If the fan motor counter becomes 7 times, then H19 - fan motor error is detected. Operation stops and cannot on back.

**12.3 Outdoor Fan Motor Operation**

Outdoor fan motor is operated with one fan speed only. It starts when compressor starts operation and it stops 30 seconds after compressor stops operation.

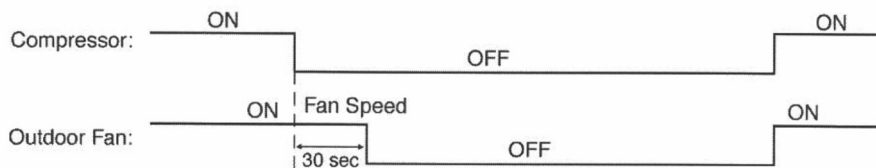

**12.4 Airflow Direction**

- There are two types of airflow, vertical airflow (directed by horizontal vane) and horizontal airflow (directed by vertical vanes).
- Control of airflow direction can be automatic (angles of direction is determined by operation mode, heat exchanger temperature and intake air temperature) and manual (angles of direction can be adjusted using remote control).

### 12.4.1 Vertical Airflow

Operation Mode	Airflow Direction		Vane Angle (°)				
			1	2	3	4	5
Heating	Auto Heat Exchanger Temperature	A	10				
		B	43.8				
		C	21.2				
	Manual		10	21.2	32.5	43.8	55
Cooling and Fan	Auto		10 ~ 40				
	Manual		10	17.5	25	32.5	40
Soft Dry	Auto		10 ~ 40				
	Manual		10	17.5	25	32.5	40

- Automatic vertical airflow direction can be set using remote control; the vane swings up and down within the angles as stated above. For heating mode operation, the angle of the vane depends on the indoor heat exchanger temperature as Figure 1 below. It does not swing during fan motor stop. When the air conditioner is stopped using remote control, the vane will shift to close position.
- Manual vertical airflow direction can be set using remote control; the angles of the vane are as stated above and the positions of the vane are as Figure 2 below. When the air conditioner is stopped using remote control, the vane will shift to close position.

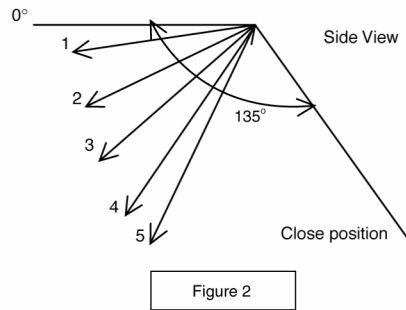
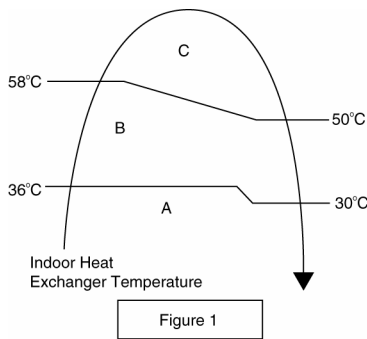

### 12.4.2 Horizontal Airflow

- The horizontal airflow direction louvers can be adjusted manually by hand.

## 12.5 Timer Control

- There are 2 sets of ON and OFF timer available to turn the unit ON or OFF at different preset time.
- If more than one timer had been set, the upcoming timer will be displayed and will activate in sequence.

### 12.5.1 ON Timer Control

- ON timer 1 and ON timer 2 can be set using remote control, the unit with timer set will start operate earlier than the setting time.  
This is to provide a comfortable environment when reaching the set ON time.
- 60 minutes before the set time, indoor (at fan speed of Lo-) and outdoor fan motor start operate for 30 seconds to determine the indoor intake air temperature and outdoor air temperature in order to judge the operation starting time.
- From the above judgment, the decided operation will start operate earlier than the set time as shown below.

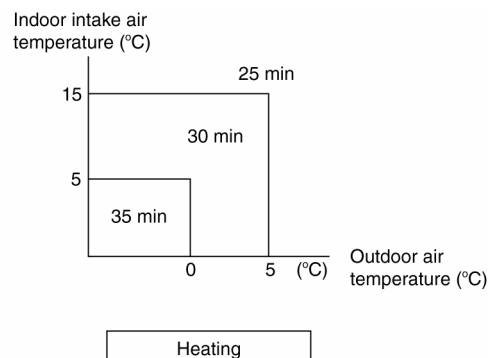
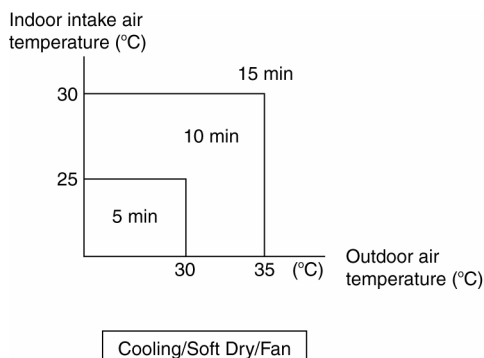

### 12.5.2 OFF Timer Control

OFF timer 1 and OFF timer 2 can be set using remote control, the unit with timer set will stop operate at set time.

### 12.6 Auto Restart Control

- 1 When the power supply is cut off during the operation of air conditioner, the compressor will re-operate within three to four minutes (there are 10 patterns between 2 minutes 58 seconds and 3 minutes 52 seconds to be selected randomly) after power supply resumes.
- 2 This type of control is not applicable during ON/OFF Timer setting.
- 3 This control can be omitted by open the circuit of JP1 at indoor unit printed circuit board.

### 12.7 Indication Panel

LED	POWER/DEICE		TIMER
Color	Green	Blue	Orange
Light ON	Operation ON	Deice Operation	Time Setting ON
Light OFF	Operation OFF		Time Setting OFF

Note:

- If POWER LED is blinking, the possible operation of the unit are Hot Start, operation mode judgment, or ON timer sampling.
- If Timer LED is blinking, there is an abnormality operation occurs.

# 13. Protection Control

## 13.1 Protection Control For All Operations

### 13.1.1 Restart Control (Time Delay Safety Control)

- The Compressor will not turn on within 3 minutes from the moment operation stops, although the unit is turned on again by pressing OFF/ON button at remote control within this period.
- This control is not applicable if the power supply is cut off and on again.
- This phenomenon is to balance the pressure inside the refrigerant cycle.

### 13.1.2 Total Running Current Control

- When the outdoor unit total running current (AC) exceeds X value, the frequency instructed for compressor operation will be decreased.
- If the running current does not exceed X value for 10 seconds, the frequency instructed will be increased.
- However, if total outdoor unit running current exceeds Y value, compressor will be stopped immediately for 3 minutes.

Model	CE9NK		CE12NK	
	X (A)	Y (A)	X (A)	Y (A)
Cooling/Soft Dry (A)	4.54	14.76	6.20	14.76
Cooling/Soft Dry (B)	3.43	14.76	5.64	14.76
Cooling/Soft Dry (C)	3.43	14.76	5.64	14.76
Heating	5.49	14.76	8.03	14.76

- The first 30 minutes of cooling operation, (A) will be applied.

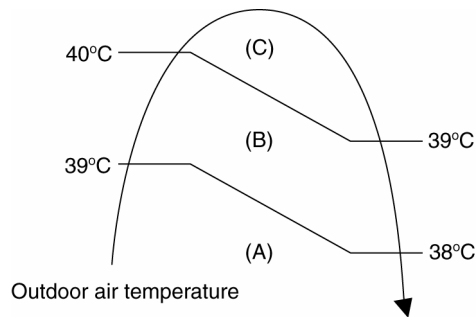

### 13.1.3 IPM (Power transistor) Prevention Control

- Overheating Prevention Control
  - When the IPM temperature rises to 100°C, compressor operation will stop immediately.
  - Compressor operation restarts after 3 minutes the temperature decreases to 95°C.
  - If this condition repeats continuously 4 times within 20 minutes, timer LED will be blinking (“F96” is indicated).
- DC Peak Current Control
  - When electric current to IPM exceeds set value of 20.2 A, the compressor will stop operate. Then, operation will restart after 3 minutes.
  - If the set value is exceeded again more than 30 seconds after the compressor starts, the operation will restart after 1 minute.
  - If the set value exceeded again within 30 seconds after the compressor starts, the operation will restart after 2 minutes. If this condition repeats continuously for 7 times, all indoor and outdoor relays will be cut off, timer LED will be blinking (“F99” is indicated).

### 13.1.4 Compressor Overheating Prevention Control

- Instructed frequency for compressor operation will be regulated by compressor discharge temperature. The changes of frequency are as below.
- If compressor discharge temperature exceeds 103°C, compressor will be stopped, occurs 4 times per 20 minutes, timer LED will be blinking. ("F97" is indicated.)

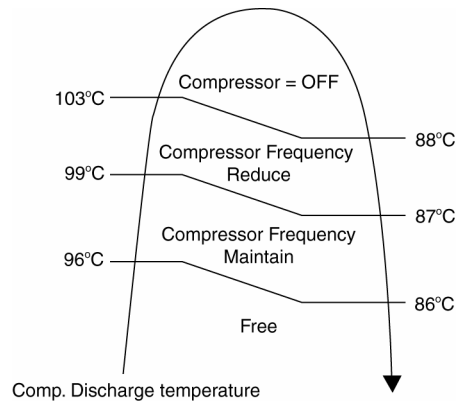

### 13.1.5 Low Pressure Prevention Control (Gas Leakage Detection)

- Control start conditions
  - For 5 minutes, the compressor continuously operates and outdoor total current is between 0.6A and 1.15A.
  - During Cooling and Soft Dry operations:  
Indoor suction temperature - indoor piping temperature is below 4°C.
  - During Heating operations :  
Indoor piping temperature - indoor suction is under 5°C.
- Control contents
  - Compressor stops (and restart after 3 minutes).
  - If the conditions above happen 2 times within 20 minutes, the unit will:
    - Stop operation.
    - Timer LED blinks and "F91" indicated.

### 13.1.6 Low Frequency Protection Control 1

- When the compressor operate at frequency lower than 24 Hz continued for 240 minutes, the operation frequency will be changed to 23 Hz for 2 minutes.

### 13.1.7 Low Frequency Protection Control 2

- When all the below conditions comply, the compressor frequency will change to lower frequency.

Temperature, T, for:	Cooling/Soft Dry	Heating
Indoor intake air (°C)	T < 14 or T ≥ 30	T < 14 or T ≥ 28
Outdoor air (°C)	T < 13 or T ≥ 38	T < 4 or T ≥ 24
Indoor heat exchanger (°C)	T < 30	T < 0



## 13.2 Protection Control For Cooling & Soft Dry Operation

### 13.2.1 Outdoor Air Temperature Control

- The compressor operating frequency is regulated in accordance to the outdoor air temperature as shown in the diagram below.
- This control will begin 1 minute after the compressor starts.
- Compressor frequency will adjust base on outdoor air temperature.

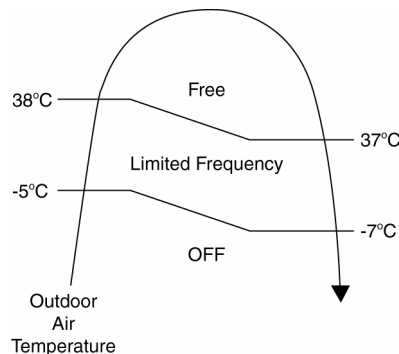

### 13.2.2 Cooling Overload Control

- Detects the Outdoor pipe temperature and carry out below restriction/limitation (Limit the compressor Operation frequency).
- The compressor stop if outdoor pipe temperature exceeds 61°C.
- If the compressor stops 4 times in 20 minutes, Timer LED blinking (F95 indicated: outdoor high pressure rise protection).

### 13.2.3 Freeze Prevention Control 1

- When indoor heat exchanger temperature is lower than 0°C continuously for 6 minutes, compressor will stop operating.
- Compressor will resume its operation 3 minutes after the indoor heat exchanger is higher than 5°C.
- At the same time, indoor fan speed will be higher than during its normal operation.
- If indoor heat exchanger temperature is higher than 5°C for 5 minutes, the fan speed will return to its normal operation.

### 13.2.4 Freeze Prevention Control 2

- Control start conditions
  - During Cooling operation and soft dry operation
    - During thermo OFF condition, indoor intake temperature is less than 10°C or
    - Compressor stops for freeze prevention control
  - Either one of the conditions above occurs 5 times in 60 minutes.
- Control contents
  - Operation stops
  - Timer LED blinks and “H99” indicated

### 13.2.5 Dew Prevention Control 1

- To prevent dew formation at indoor unit discharge area.
- This control will be activated if:
  - Outdoor air temperature and Indoor pipe temperature judgment by microcontroller is fulfilled.
  - When Cooling or Dry mode is operated more than 20 minutes or more.
- This control stopped if:
  - Compressor stopped.
  - Remote control setting changed (fan speed / temperature).
  - Outdoor air temperature and indoor intake temperature changed.
- Fan speed, angle of louver (vertical airflow angle) will be adjusted accordingly in this control.

### 13.2.6 Dew Prevention Control 2

- To prevent dew formation at indoor unit discharge area.
- This control starts if all conditions continue for 20 minutes:
  - Operated with Cooling or Soft Dry Mode.
  - Indoor intake temperature is between 25°C and 29°C.
  - Outdoor air temperature is less than 30°C.
- This control stopped if:
  - When receive air swing change signal from Remote Control.
- The vertical airflow angle will be fixed at 17.5°.

### 13.2.7 Odor Cut Control

- To reduce the odor released from the unit.
  - Start Condition
    - AUTO FAN Speed is selected during COOL or DRY operation.
    - During freeze prevention control and timer preliminary operation, this control is not applicable.
  - Control content
    - Depends on compressor conditions:
      - Compressor OFF → Compressor ON.  
The indoor unit fan stops temporarily and then starts to blow at minimum airflow for 30 seconds.
      - Compressor ON → Compressor OFF.  
The indoor unit fan stops for 90 seconds and then blows at minimum airflow for 20 seconds.

## 13.3 Protection Control For Heating Operation

### 13.3.1 Intake Air Temperature Control

Compressor will operate at limited freq., if indoor intake air temperature is 30°C or above.

### 13.3.2 Outdoor Air Temperature Control

- The Max current value is regulated when the outdoor air temperature rise above 14°C in order to avoid compressor overloading.

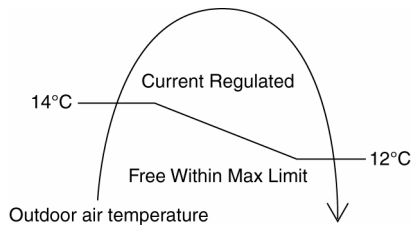

### 13.3.3 Overload Protection Control

- The compressor operating frequency is regulated in accordance to indoor heat exchanger temperature as shown below.
- If the heat exchanger temperature exceeds 60°C, compressor will stop.

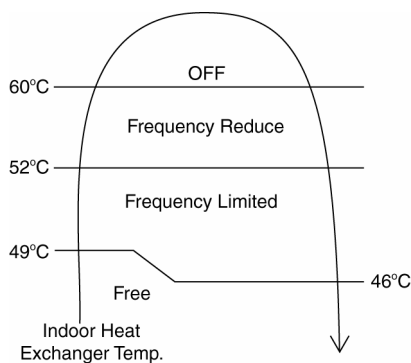

#### **13.3.4 Compressor Oil Return Control**

- When compressor starts, the compressor will be regulated for 240 seconds.

#### **13.3.5 Cold Draught Prevention Control**

- When indoor pipe temperature is low, cold draught operation starts where indoor fan speed will be reduced.

#### **13.3.6 Deice Operation**

- When outdoor pipe temperature and outdoor air temperature is low, deice operation start where indoor fan motor and outdoor fan motor stop and the operation LED deice indicator ON during this operation.

# 14. Servicing Mode

## 14.1 Auto OFF/ON Button

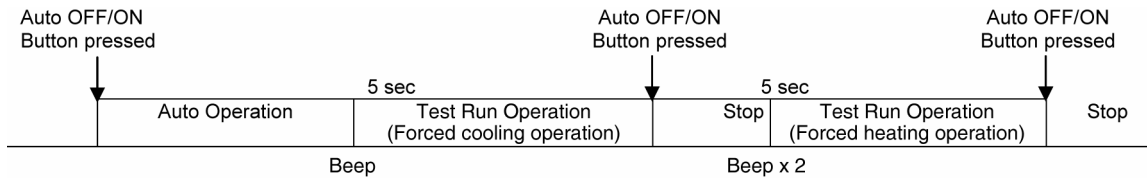

### 1 AUTO OPERATION MODE

The Auto operation will be activated immediately once the Auto OFF/ON button is pressed. This operation can be used to operate air conditioner with limited function if remote control is misplaced or malfunction.

### 2 TEST RUN OPERATION (FOR PUMP DOWN/SERVICING PURPOSE)

The Test Run operation will be activated if the Auto OFF/ON button is pressed continuously for more than 5 seconds. A “beep” sound will heard at the fifth seconds, in order to identify the starting of Test Run operation (Forced cooling operation). Within 5 minutes after Forced cooling operation start, the Auto OFF/ON button is pressed for more than 5 seconds. A 2 “beep” sounds will heard at the fifth seconds, in order to identify the starting of Forced heating operation.

The Auto OFF/ON button may be used together with remote control to set / change the advance setting of air conditioner operation.

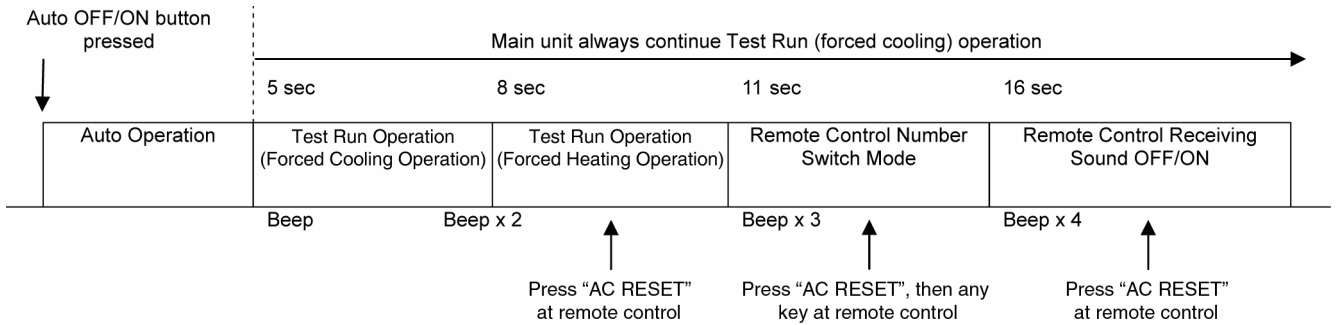

### 3 REMOTE CONTROL NUMBER SWITCH MODE

The Remote Control Number Switch Mode will be activated if the Auto OFF/ON button is pressed continuously for more than 11 seconds (3 “beep” sounds will occur at 11th seconds to identify the Remote Control Number Switch Mode is in standby condition) and press “AC RESET” button and then press any button at remote control to transmit and store the desired transmission code to the EEPROM.

There are 4 types of remote control transmission code could be selected and stored in EEPROM of indoor unit. The indoor unit will only operate when received signal with same transmission code from remote control. This could prevent signal interference when there are 2 or more indoor units installed nearby together. To change remote control transmission code, short or open jumpers at the remote control printed circuit board.

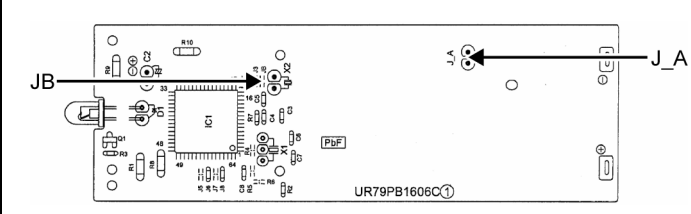

Remote Control Printed Circuit Board		
Jumper A (J_A)	Jumper B (J_B)	Remote Control No.
Short	Open	A (Default)
Open	Open	B
Short	Short	C
Open	Short	D

- During Remote Control Number Switch Mode, press any button at remote control to transmit and store the transmission code to the EEPROM.

#### 4 REMOTE CONTROL RECEIVING SOUND OFF/ON MODE

The Remote Control Receiving Sound OFF/ON Mode will be activated if the Auto OFF/ON button is pressed continuously for more than 16 seconds (4 “beep” sounds will occur at 16th seconds to identify the Remote Control Receiving Sound Off/On Mode is in standby condition) and press “AC Reset” button at remote control.

Press “Auto OFF/ON button” to toggle remote control receiving sound.

- Short “beep”: Turn OFF remote control receiving sound.
- Long “beep”: Turn ON remote control receiving sound.

After Auto OFF/ON Button is pressed, the 20 seconds counter for Remote Control Receiving Sound OFF/ON Mode is restarted.

## **14.2 Remote Control Button**

### **14.2.1 SET BUTTON**

- To check remote control transmission code and store the transmission code to EEPROM
  - Press “SET” button for more than 10 seconds by using pointer.
  - Press “TIMER SET” button until a “beep” sound is heard as confirmation of transmission code changed.

### **14.2.2 RESET (RC)**

- To clear and restore the remote control setting to factory default.
  - Press once to clear the memory.

### **14.2.3 RESET (AC)**

- To restore the unit’s setting to factory default
  - Press once to restore the unit’s setting.

### **14.2.4 TIMER ▲**

- To change indoor unit indicator’s LED intensity
  - Press continuously for 5 seconds.

### **14.2.5 TIMER ▼**

- To change remote control display from Degree Celsius (°C) to Degree Fahrenheit (°F)
  - Press continuously for 10 seconds.

# 15. Troubleshooting Guide

## 15.1 Refrigeration Cycle System

In order to diagnose malfunctions, make sure that there are no electrical problems before inspecting the refrigeration cycle. Such problems include insufficient insulation, problem with the power source, malfunction of a compressor and a fan. The normal outlet air temperature and pressure of the refrigeration cycle depends on various conditions, the standard values for them are shown in the table on the right.

Normal Pressure and Outlet Air Temperature (Standard)

	Gas pressure MPa (kg/cm <sup>2</sup> G)	Outlet air temperature (°C)
Cooling Mode	0.9 ~ 1.2 (9 ~ 12)	12 ~ 16
Heating Mode	2.3 ~ 2.9 (23 ~ 29)	36 ~ 45

- \*Condition:
- Indoor fan speed; High
  - Outdoor temperature 35°C at cooling mode and 7°C at heating mode
  - Compressor operates at rated frequency

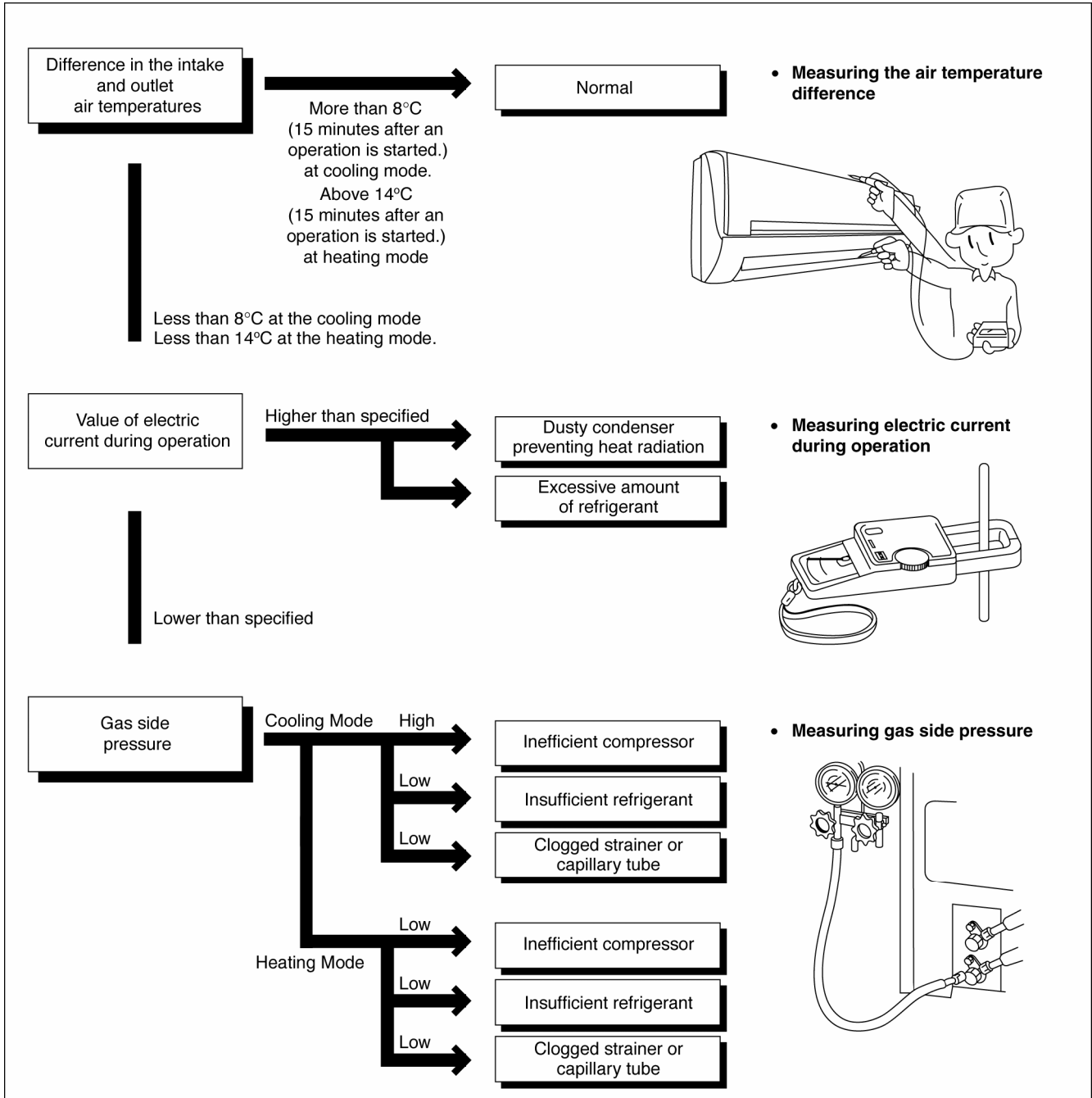

### 15.1.1 Relationship between the condition of the air conditioner and pressure and electric current

Condition of the air conditioner	Cooling Mode			Heating Mode		
	Low Pressure	High Pressure	Electric current during operation	Low Pressure	High Pressure	Electric current during operation
Insufficient refrigerant (gas leakage)	↘	↘	↘	↘	↘	↘
Clogged capillary tube or strainer	↘	↘	↘	↗	↗	↗
Short circuit in the indoor unit	↘	↘	↘	↗	↗	↗
Heat radiation deficiency of the outdoor unit	↗	↗	↗	↘	↘	↘
Inefficient compression	↗	↘	↘	↗	↘	↘

- Carry out the measurement of pressure, electric current, and temperature fifteen minutes after an operation is started.

## 15.2 Breakdown Self Diagnosis Function

### 15.2.1 Self Diagnosis Function (Three Digits Alphanumeric Code)

- Once abnormality has occurred during operation, the unit will stop its operation, and Timer LED blinks.
  - Although Timer LED goes off when power supply is turned off, if the unit is operated under a breakdown condition, the LED will light up again.
  - In operation after breakdown repair, the Timer LED will no more blink. The last error code (abnormality) will be stored in IC memory.
- 5 Every press of the button (up or down) will increase abnormality numbers and transmit abnormality code signal to the main unit.
  - 6 When the latest abnormality code on the main unit and code transmitted from the remote controller are matched, power LED will light up for 30 seconds and a beep sound (continuously for 4 seconds) will be heard. If no codes are matched, power LED will light up for 0.5 seconds and no sound will be heard.

### 15.2.2 To Make a Diagnosis

- 1 Timer LED start to blink and the unit automatically stops the operation.
- 2 Press the CHECK button on the remote controller continuously for 5 seconds.
- 3 “- -” will be displayed on the remote controller display.  
Note: Display only for “- -”. (No transmitting signal, no receiving sound and no Power LED blinking.)
- 4 Press the “TIMER” ▲ or ▼ button on the remote controller. The code “H00” (no abnormality) will be displayed and signal will be transmitted to the main unit.
- 5 Every press of the button (up or down) will increase abnormality numbers and transmit abnormality code signal to the main unit.
- 6 When the latest abnormality code on the main unit and code transmitted from the remote controller are matched, power LED will light up for 30 seconds and a beep sound (continuously for 4 seconds) will be heard. If no codes are matched, power LED will light up for 0.5 seconds and no sound will be heard.
- 7 The breakdown diagnosis mode will be canceled unless pressing the CHECK button continuously for 5 seconds or operating the unit for 30 seconds.
- 8 The LED will be off if the unit is turned off or the RESET button on the main unit is pressed.

### 15.2.3 To Display Memorized Error (Protective Operation) status

- 1 Turn power on.
- 2 Press the CHECK button on the remote controller continuously for 5 seconds.
- 3 “- -” will be displayed on the remote controller display.  
Note: Display only for “- -”. (No transmitting signal, no receiving sound and no Power LED blinking.)
- 4 Press the “TIMER” ▲ or ▼ button on the remote controller. The code “H00” (no abnormality) will be displayed and signal will be transmitted to the main unit. The power LED lights up. If no abnormality is stored in the memory, three beeps sound will be heard.

- 7 The breakdown diagnosis mode will be canceled unless pressing the CHECK button continuously for 5 seconds or operating the unit for 30 seconds.
- 8 The same diagnosis can be repeated by turning power on again.

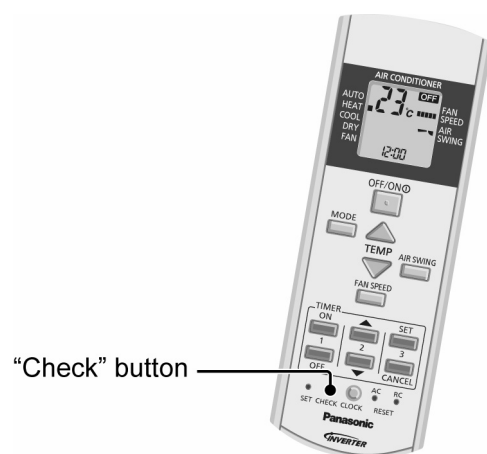

### 15.2.4 To Clear Memorized Error (Protective Operation) status after Repair

- 1 Turn power on (in standby condition).
- 2 Press the AUTO button for 5 seconds (A beep receiving sound) on the main unit to operate the unit at Forced Cooling Operation modes.
- 3 Press the CHECK button on the remote controller for about 1 second with a pointed object to transmit signal to main unit. A beep sound is heard from main unit and the data is cleared.

### 15.2.5 Temporary Operation (Depending On Breakdown Status)

- 1 Press the AUTO button (A beep receiving sound) on the main unit to operate the unit. (Remote control will become possible.)
- 2 The unit can temporarily be used until repaired.



## 15.3 Error Codes Table

Diagnosis display	Abnormality / Protection control	Abnormality Judgement	Protection operation	Problem	Check location
H00	No memory of failure	—	Normal operation	—	—
H11	Indoor/outdoor abnormal communication	After operation for 1 minute	Indoor fan only operation can start by entering into force cooling operation	Indoor/outdoor communication not establish	<ul style="list-style-type: none"> <li>Indoor/outdoor wire terminal</li> <li>Indoor/outdoor PCB</li> <li>Indoor/outdoor connection wire</li> </ul>
H14	Indoor intake air temperature sensor abnormality	Continuous for 5s	—	Indoor intake air temperature sensor open or short circuit	<ul style="list-style-type: none"> <li>Indoor intake air temperature sensor lead wire and connector</li> </ul>
H15	Compressor temperature sensor abnormality	Continuous for 5s	—	Compressor temperature sensor open or short circuit	<ul style="list-style-type: none"> <li>Compressor temperature sensor lead wire and connector</li> </ul>
H16	Outdoor current transformer (CT) abnormality	—	—	Current transformer faulty or compressor faulty	<ul style="list-style-type: none"> <li>Outdoor PCB faulty or compressor faulty</li> </ul>
H19	Indoor fan motor mechanism lock	Continuous happen for 7 times	—	Indoor fan motor lock or feedback abnormal	<ul style="list-style-type: none"> <li>Fan motor lead wire and connector</li> <li>Fan motor lock or block</li> </ul>
H23	Indoor heat exchanger temperature sensor abnormality	Continuous for 5s	—	Indoor heat exchanger temperature sensor open or short circuit	<ul style="list-style-type: none"> <li>Indoor heat exchanger temperature sensor lead wire and connector</li> </ul>
H27	Outdoor air temperature sensor abnormality	Continuous for 5s	—	Outdoor air temperature sensor open or short circuit	<ul style="list-style-type: none"> <li>Outdoor air temperature sensor lead wire and connector</li> </ul>
H28	Outdoor heat exchanger temperature sensor 1 abnormality	Continuous for 5s	—	Outdoor heat exchanger temperature sensor 1 open or short circuit	<ul style="list-style-type: none"> <li>Outdoor heat exchanger temperature sensor 1 lead wire and connector</li> </ul>
H30	Outdoor discharge pipe temperature sensor abnormality	Continuous for 5s	—	Outdoor discharge pipe temperature sensor open or short circuit	<ul style="list-style-type: none"> <li>Outdoor discharge pipe temperature sensor lead wire and connector</li> </ul>
H33	Indoor / outdoor misconnection abnormality	—	—	Indoor and outdoor rated voltage different	<ul style="list-style-type: none"> <li>Indoor and outdoor units check</li> </ul>
H38	Indoor/Outdoor mismatch (brand code)	—	—	Brand code not match	<ul style="list-style-type: none"> <li>Check indoor unit and outdoor unit.</li> </ul>
H97	Outdoor fan motor mechanism lock	2 times happen within 30 minutes	—	Outdoor fan motor lock or feedback abnormal	<ul style="list-style-type: none"> <li>Outdoor fan motor lead wire and connector</li> <li>Fan motor lock or block</li> </ul>
H98	Indoor high pressure protection	—	—	Indoor high pressure protection (Heating)	<ul style="list-style-type: none"> <li>Check indoor heat exchanger</li> <li>Air filter dirty</li> <li>Air circulation short circuit</li> </ul>
H99	Indoor operating unit freeze protection	—	—	Indoor freeze protection (Cooling)	<ul style="list-style-type: none"> <li>Check indoor heat exchanger</li> <li>Air filter dirty</li> <li>Air circulation short circuit</li> </ul>
F11	4-way valve switching abnormality	4 times happen within 30 minutes	—	4-way valve switching abnormal	<ul style="list-style-type: none"> <li>4-way valve</li> <li>Lead wire and connector.</li> </ul>
F90	Power factor correction (PFC) circuit protection	4 times happen within 10 minutes	—	Power factor correction circuit abnormal	<ul style="list-style-type: none"> <li>Outdoor PCB faulty</li> </ul>
F91	Refrigeration cycle abnormality	2 times happen within 20 minutes	—	Refrigeration cycle abnormal	<ul style="list-style-type: none"> <li>Insufficient refrigerant or valve close</li> </ul>
F93	Compressor abnormal revolution	4 times happen within 20 minutes	—	Compressor abnormal revolution	<ul style="list-style-type: none"> <li>Power transistor module faulty or compressor lock</li> </ul>
F95	Outdoor cooling high pressure protection	4 times happen within 20 minutes	—	Cooling high pressure protection	<ul style="list-style-type: none"> <li>Check refrigeration system</li> <li>Outdoor air circuit</li> </ul>
F96	Power transistor module overheating protection	4 times happen within 30 minutes	—	Power transistor module overheat	<ul style="list-style-type: none"> <li>PCB faulty</li> <li>Outdoor air circuit (fan motor)</li> </ul>

<b>Diagnosis display</b>	<b>Abnormality / Protection control</b>	<b>Abnormality Judgement</b>	<b>Protection operation</b>	<b>Problem</b>	<b>Check location</b>
F97	Compressor overheating protection	3 times happen within 30 minutes	—	Compressor overheat	• Insufficient refrigerant
F98	Total running current protection	3 times happen within 20 minutes	—	Total current protection	• Check refrigeration system • Power source or compressor lock
F99	Outdoor direct current (DC) peak detection	Continuous happen for 7 times	—	Power transistor module current protection	• Power transistor module faulty or compressor lock

## 15.4 Self-diagnosis Method

### 15.4.1 H11 (Indoor/Outdoor Abnormal Communication)

#### Malfunction Decision Conditions

- During startup and operation of cooling and heating, the data received from outdoor unit in indoor unit signal transmission is checked whether it is normal.

#### Malfunction Caused

- Faulty indoor unit PCB.
- Faulty outdoor unit PCB.
- Indoor unit-outdoor unit signal transmission error due to wrong wiring.
- Indoor unit-outdoor unit signal transmission error due to breaking of wire in the connection wires between the indoor and outdoor units.
- Indoor unit-outdoor unit signal transmission error due to disturbed power supply waveform.

#### Troubleshooting

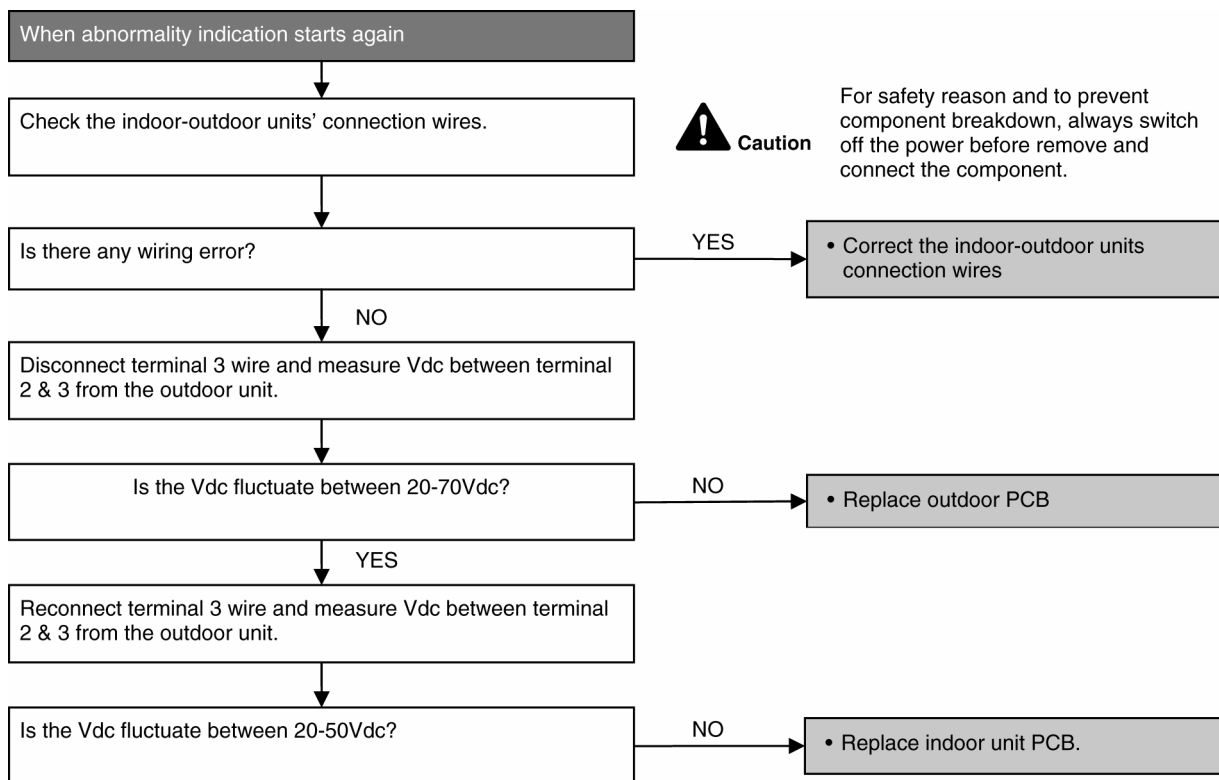

## 15.4.2 H14 (Indoor Intake Air Temperature Sensor Abnormality)

### Malfunction Decision Conditions

- During startup and operation of cooling and heating, the temperatures detected by the indoor intake air temperature sensor are used to determine sensor errors.

### Malfunction Caused

- Faulty connector connection.
- Faulty sensor.
- Faulty PCB.

### Troubleshooting

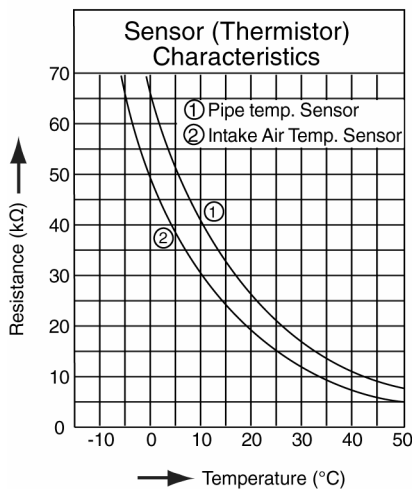
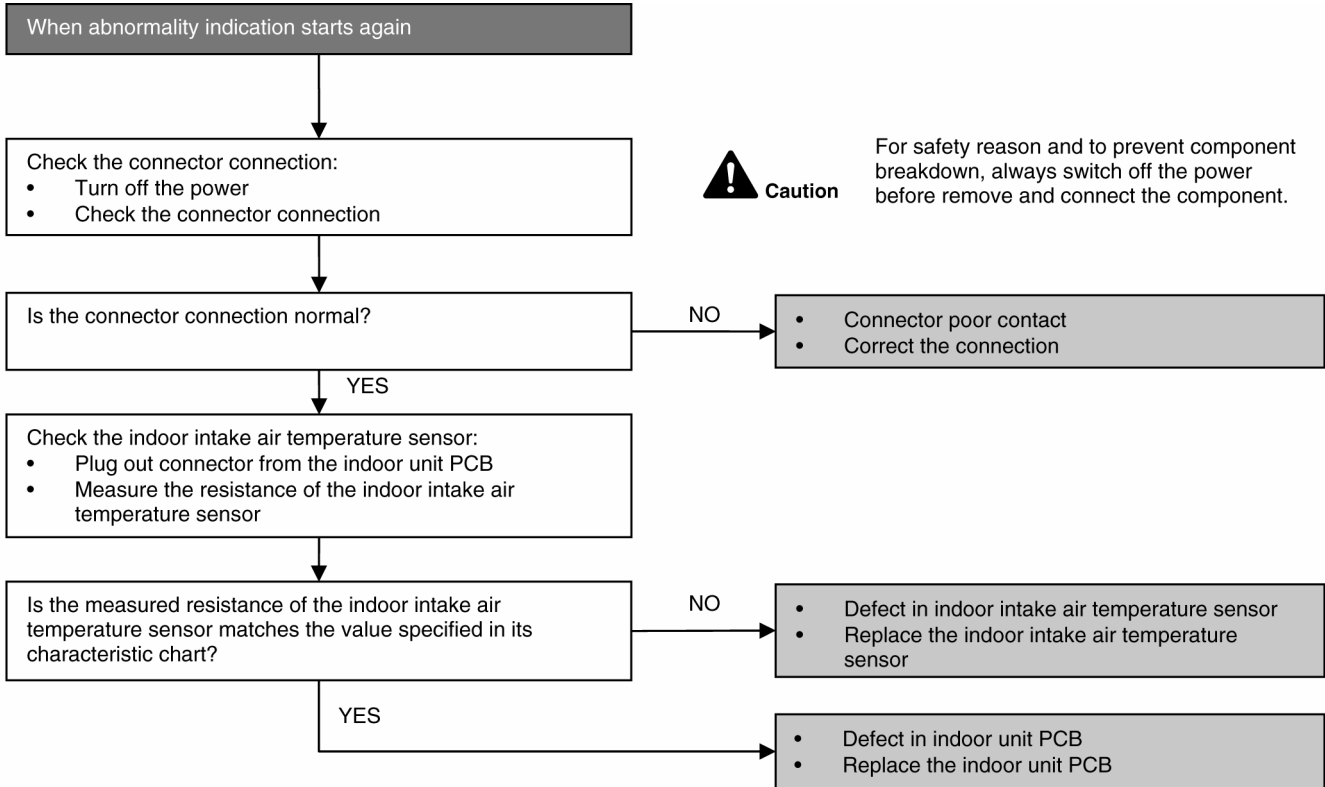

### 15.4.3 H15 (Compressor Temperature Sensor Abnormality)

#### Malfunction Decision Conditions

- During startup and operation of cooling and heating, the temperatures detected by the outdoor compressor temperature sensor are used to determine sensor errors.

#### Malfunction Caused

- Faulty connector connection.
- Faulty sensor.
- Faulty PCB.

#### Troubleshooting

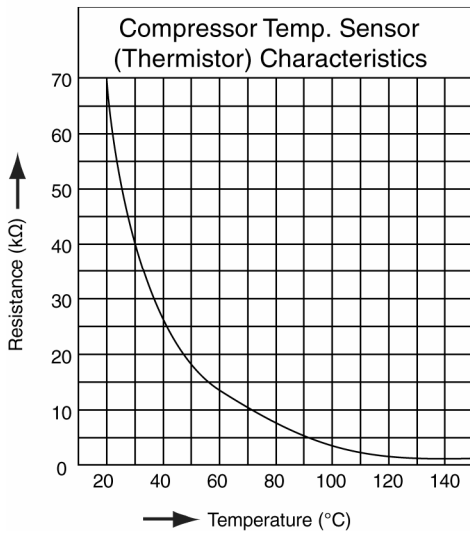
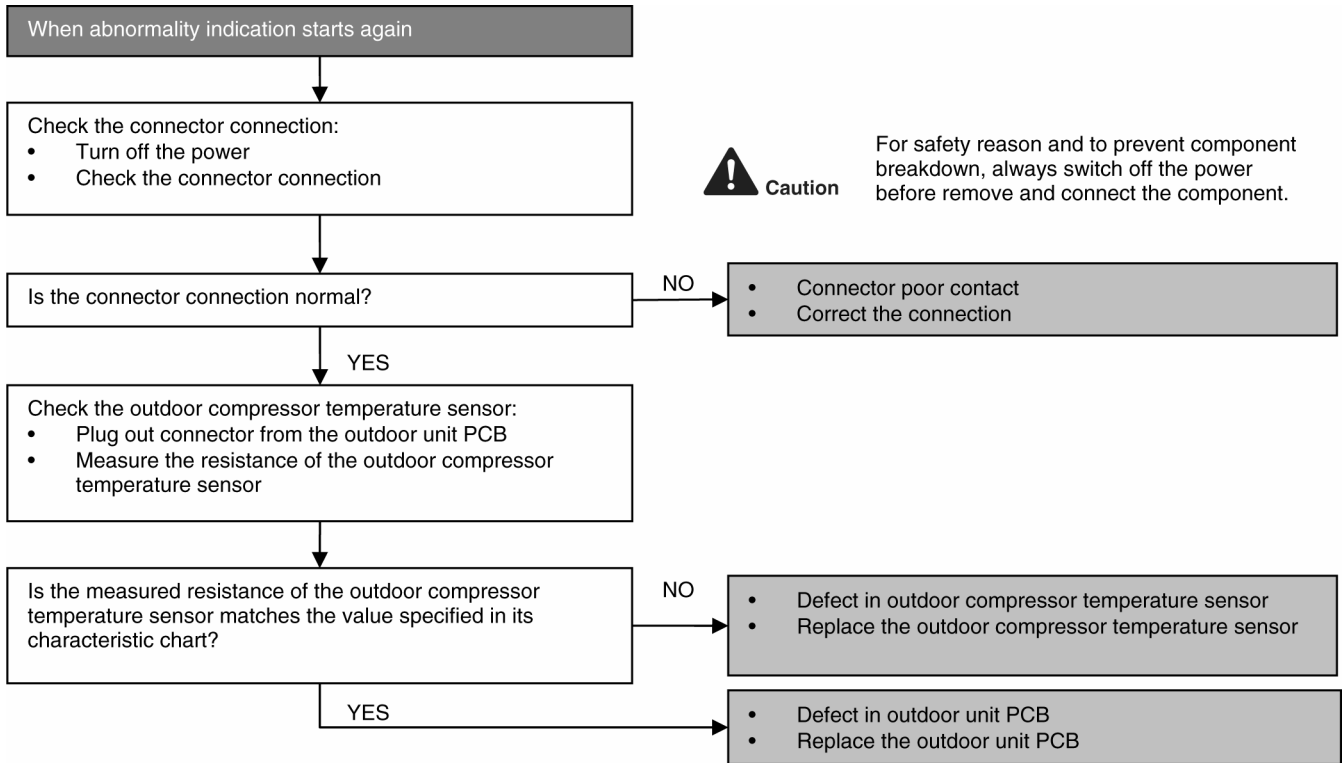

## 15.4.4 H16 (Outdoor Current Transformer Open Circuit)

### Malfunction Decision Conditions

- A current transformer (CT) is detected by checking the compressor running frequency ( $\geq$  rated frequency) and CT detected input current (less than 0.65A) for continuously 20 seconds.

### Malfunction Caused

- CT defective
- Outdoor PCB defective
- Compressor defective (low compression)

### Troubleshooting

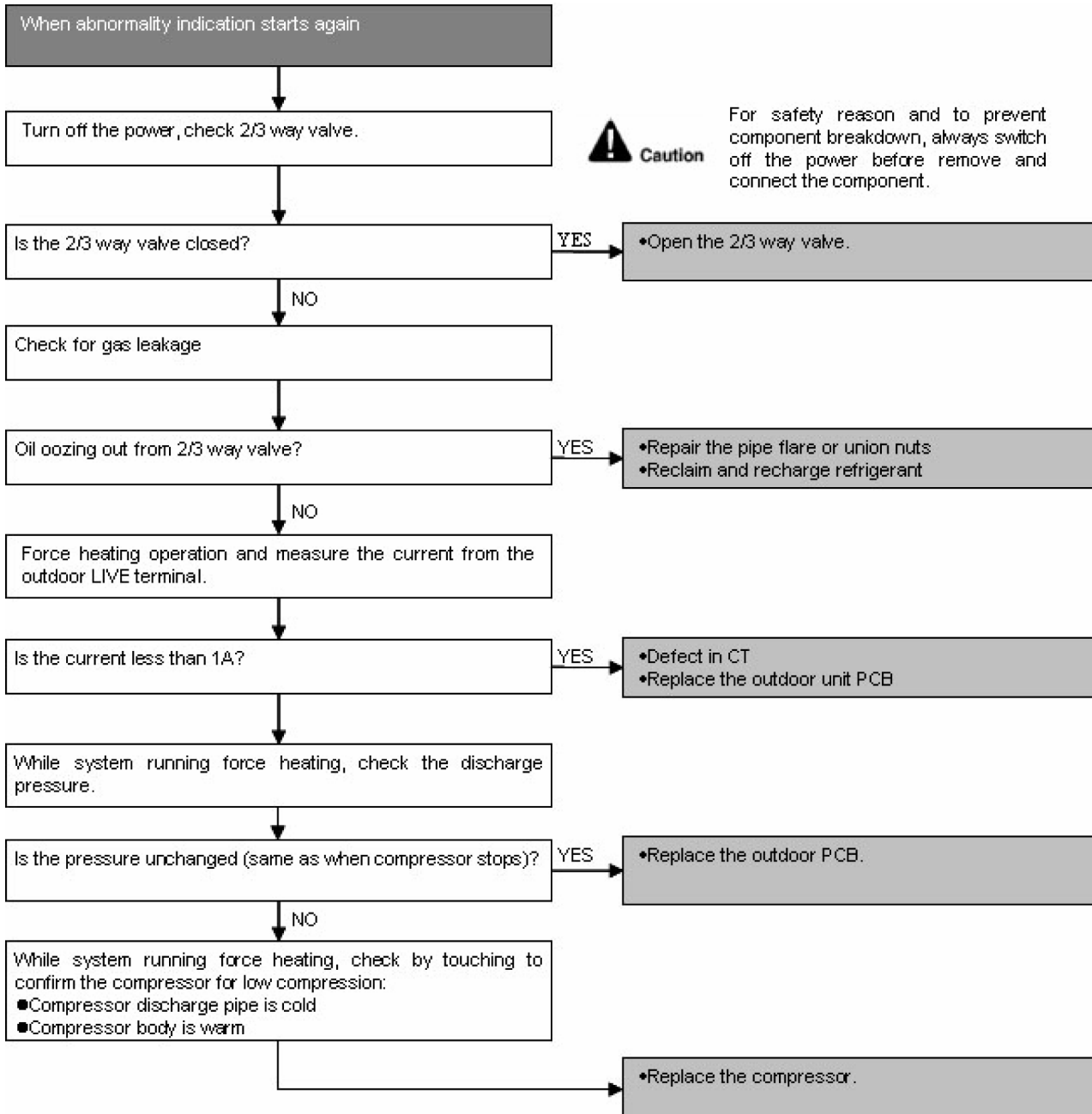

### 15.4.5 H19 (Indoor Fan Motor – DC Motor Mechanism Locked)

#### Malfunction Decision Conditions

- The rotation speed detected by the Hall IC during fan motor operation is used to determine abnormal fan motor (feedback of rotation > 2550rpm or < 50rpm)

#### Malfunction Caused

- Operation stops due to short circuit inside the fan motor winding.
- Operation stops due to breaking of wire inside the fan motor.
- Operation stops due to breaking of fan motor lead wires.
- Operation stops due to Hall IC malfunction.
- Operation error due to faulty indoor unit PCB.

#### Troubleshooting

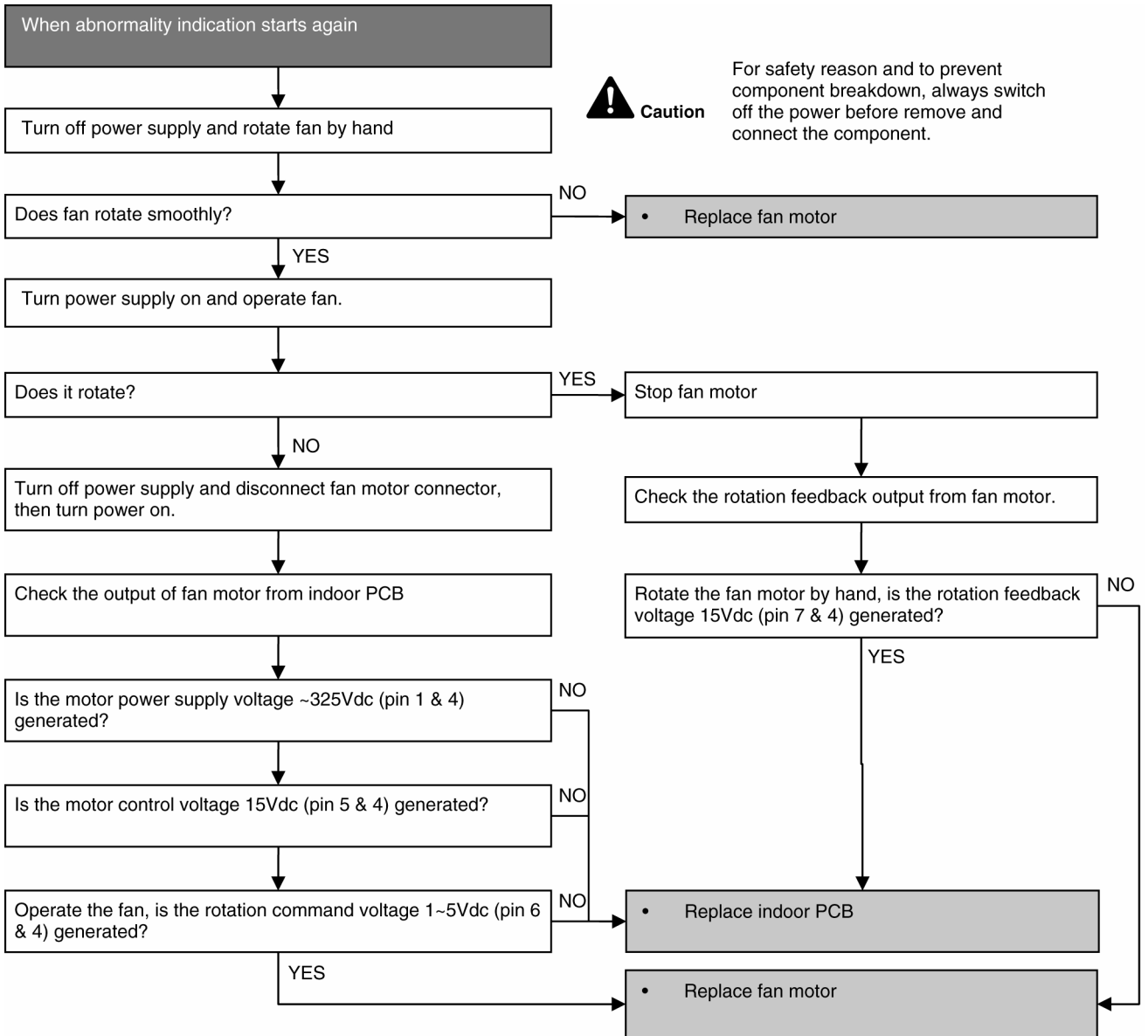

## 15.4.6 H23 (Indoor Pipe Temperature Sensor Abnormality)

### Malfunction Decision Conditions

- During startup and operation of cooling and heating, the temperatures detected by the indoor heat exchanger temperature sensor are used to determine sensor errors.

### Malfunction Caused

- Faulty connector connection.
- Faulty sensor.
- Faulty PCB.

### Troubleshooting

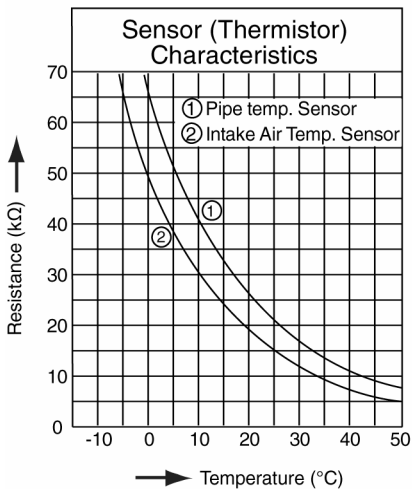
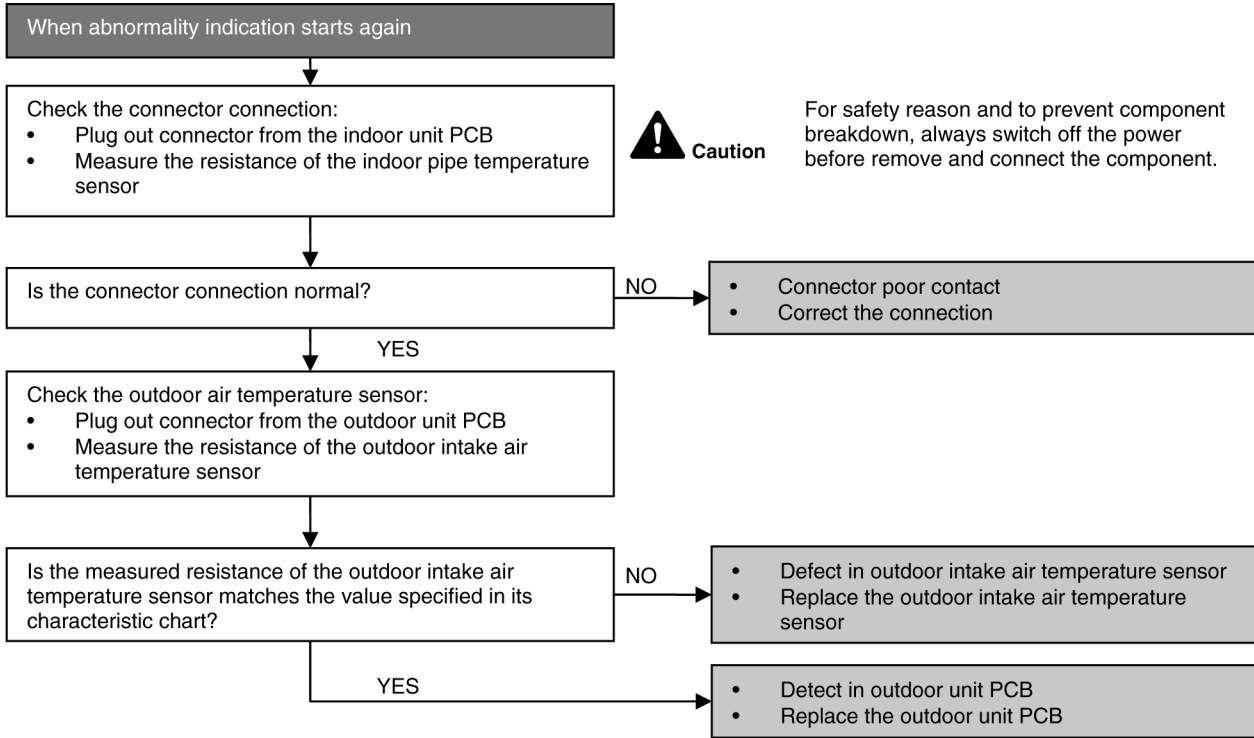



## 15.4.7 H27 (Outdoor Air Temperature Sensor Abnormality)

### Malfunction Decision Conditions

- During startup and operation of cooling and heating, the temperatures detected by the outdoor air temperature sensor are used to determine sensor errors.

### Malfunction Caused

- Faulty connector connection.
- Faulty sensor.
- Faulty PCB.

### Troubleshooting

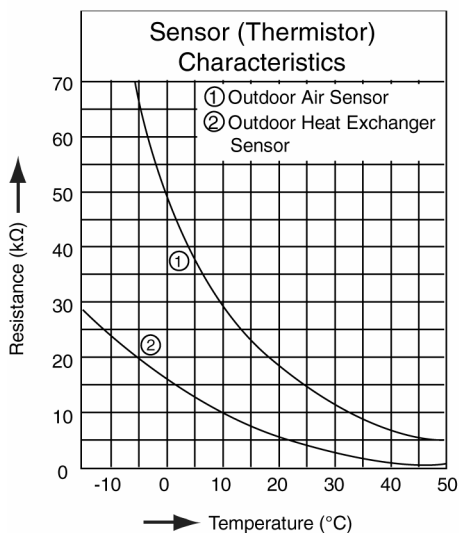
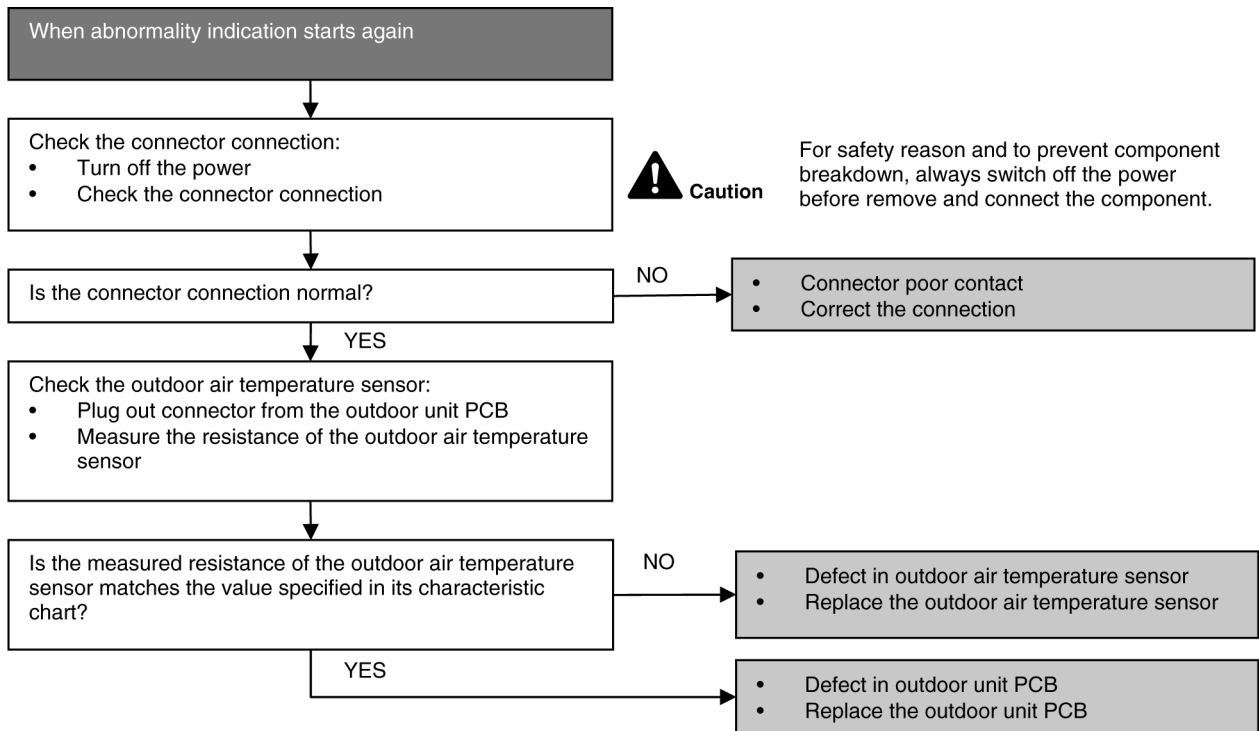

## 15.4.8 H28 (Outdoor Pipe Temperature Sensor Abnormality)

### Malfunction Decision Conditions

- During startup and operation of cooling and heating, the temperatures detected by the outdoor pipe temperature sensor are used to determine sensor errors.

### Malfunction Caused

- Faulty connector connection.
- Faulty sensor.
- Faulty PCB.

### Troubleshooting

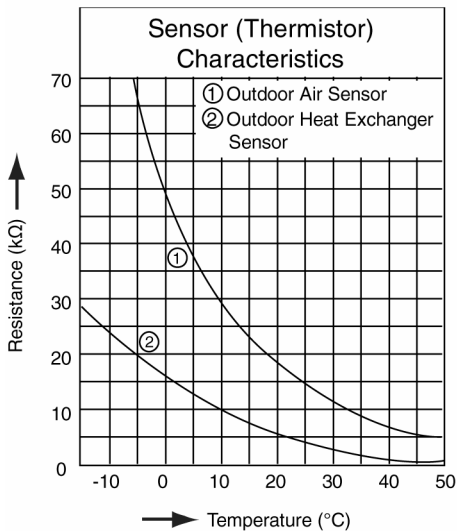
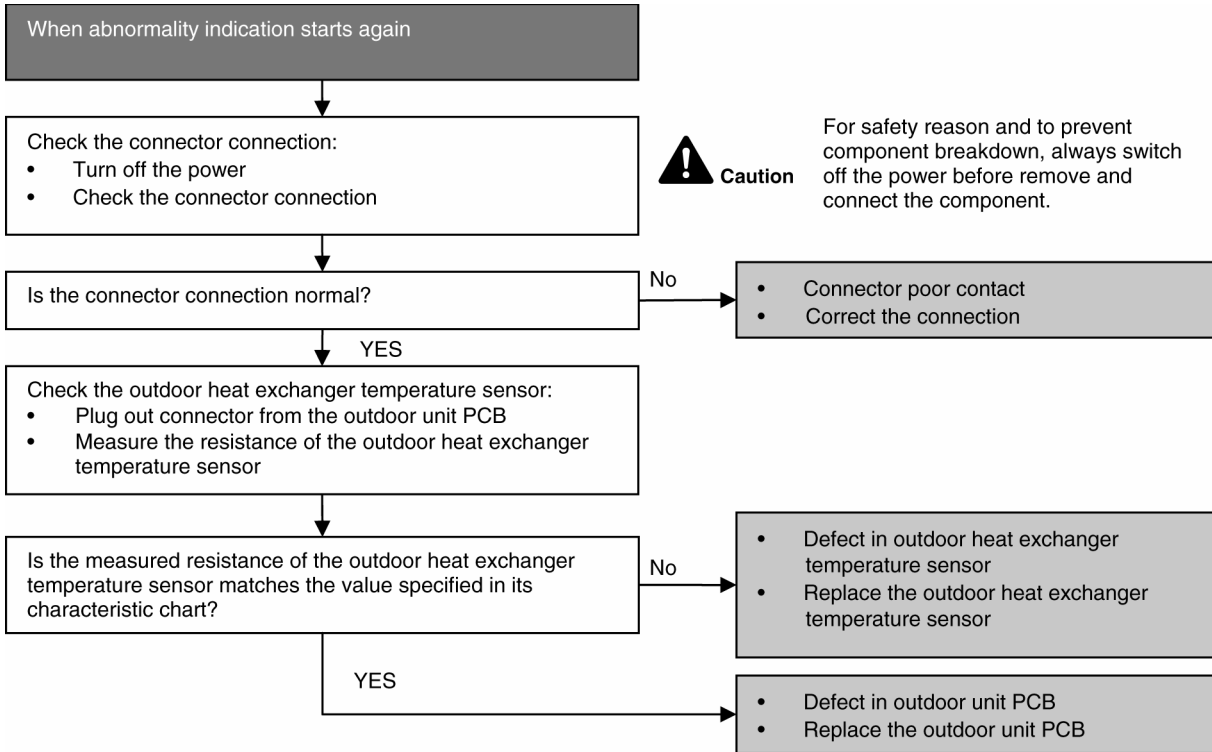

### 15.4.9 H30 (Compressor Discharge Temperature Sensor Abnormality)

#### Malfunction Decision Conditions

- During startup and operation of cooling and heating, the temperatures detected by the outdoor discharge pipe temperature sensor are used to determine sensor errors.

#### Malfunction Caused

- Faulty connector connection.
- Faulty sensor.
- Faulty PCB.

#### Troubleshooting

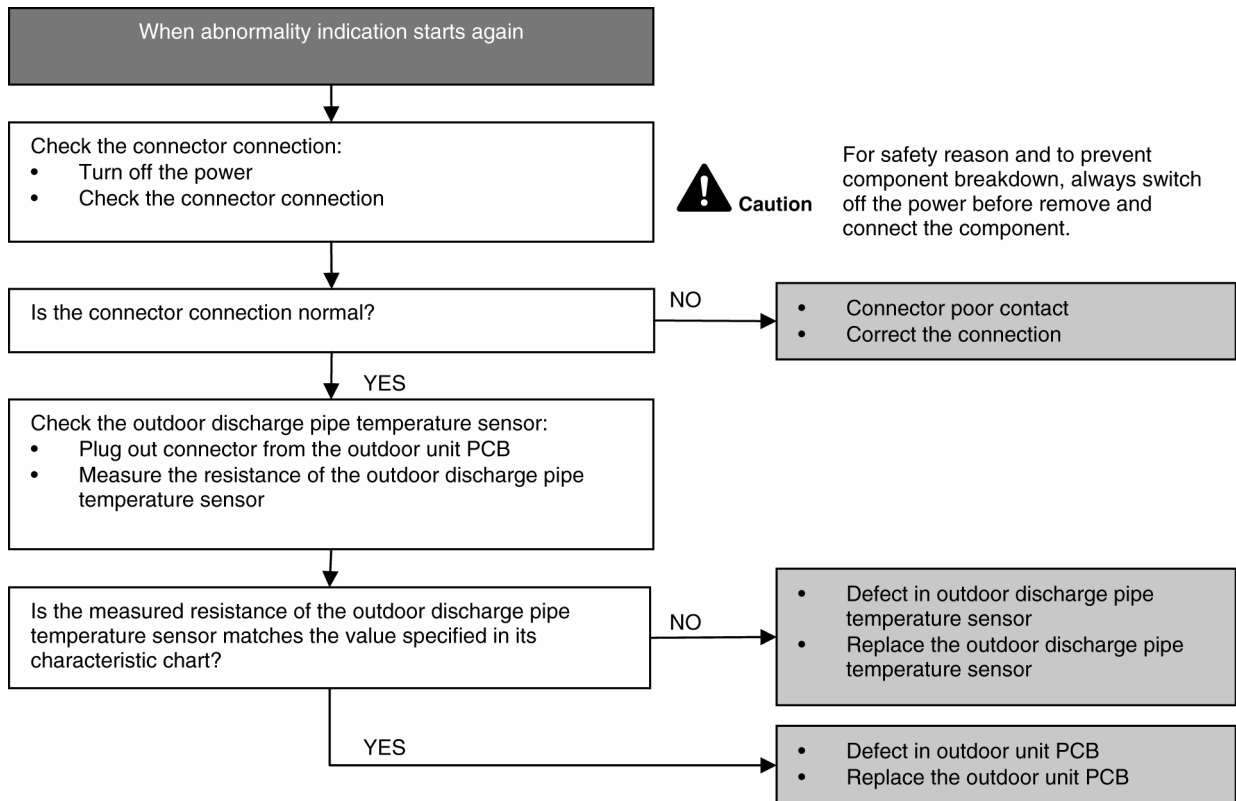

### 15.4.10 H33 (Unspecified Voltage between Indoor and Outdoor)

#### Malfunction Decision Conditions

- The supply power is detected for its requirement by the indoor/outdoor transmission.

#### Malfunction Caused

- Wrong models interconnected.
- Wrong indoor unit and outdoor unit PCBs used.
- Indoor unit or outdoor unit PCB defective.

#### Troubleshooting

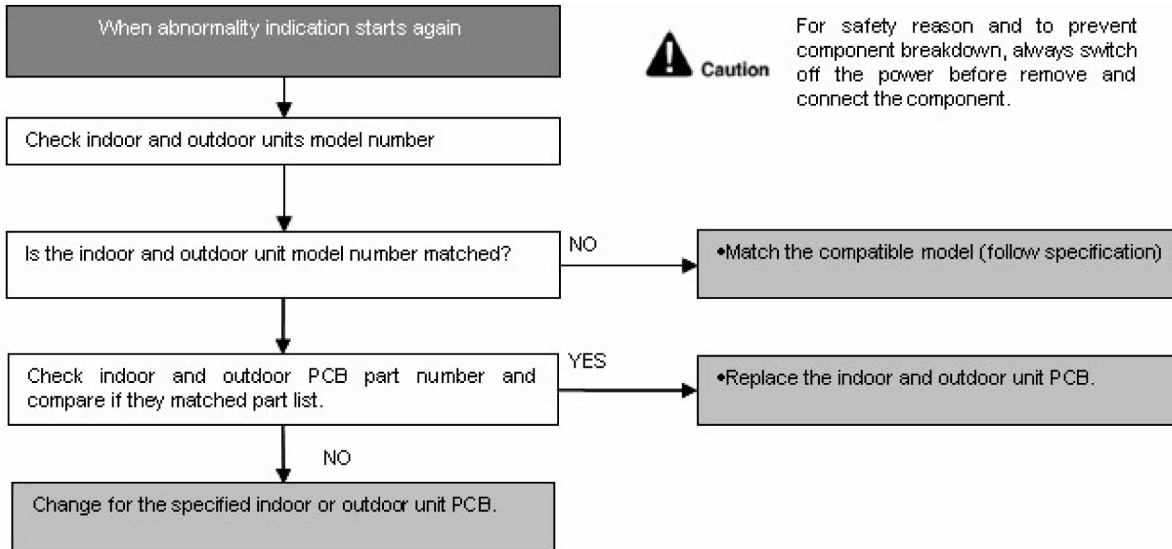

### 15.4.11 H97 (Outdoor Fan Motor – DC Motor Mechanism Locked)

#### Malfunction Decision Conditions

- The rotation speed detected by the Hall IC during fan motor operation is used to determine abnormal fan motor.

#### Malfunction Caused

- Operation stops due to short circuit inside the fan motor winding.
- Operation stops due to breaking of wire inside the fan motor.
- Operation stops due to breaking of fan motor lead wires.
- Operation stops due to Hall IC malfunction.
- Operation error due to faulty outdoor unit PCB.

#### Troubleshooting

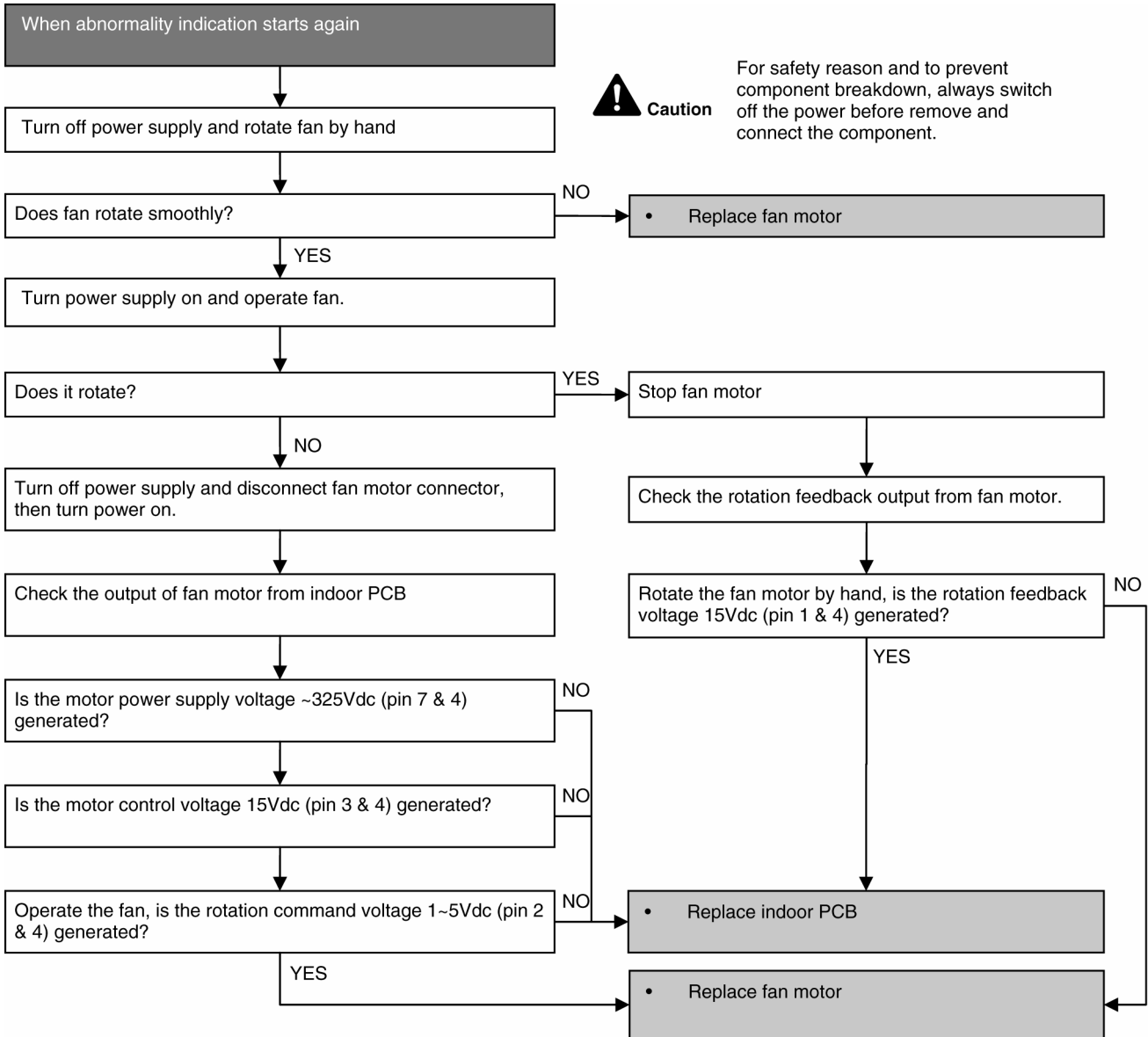

## 15.4.12 H98 (Indoor High Pressure Protection)

Error Code will not display (no Timer LED blinking) but store in EEPROM

### Malfunction Decision Conditions

- During heating operation, the temperature detected by the indoor pipe temperature sensor is above 60°C.

### Malfunction Caused

- Air short circuit at indoor unit
- Clogged indoor unit air filter
- Dust accumulation on the indoor unit heat exchanger
- 2/3 way valve closed
- Faulty indoor unit fan motor
- Excessive refrigerant
- Clogged expansion valve or strainer
- Faulty indoor pipe temperature sensor
- Faulty indoor unit PCB

### Troubleshooting

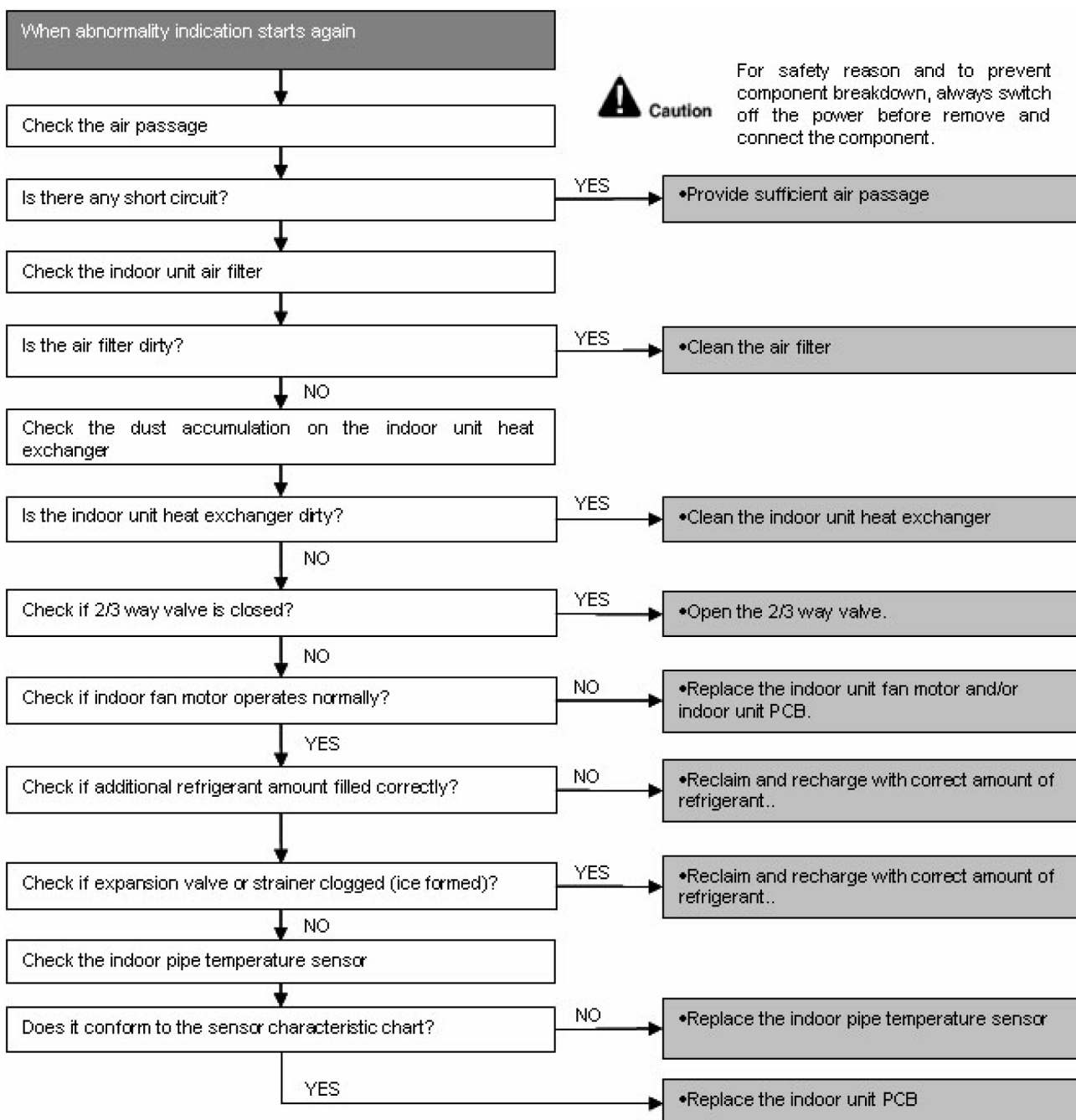

### 15.4.13 H99 (Indoor Freeze Prevention Protection: Cooling or Soft Dry)

Error Code will not display (no Timer LED blinking) but store in EEPROM

#### Malfunction Decision Conditions

- Freeze prevention control takes place (when indoor pipe temperature is lower than 2°C)

#### Malfunction Caused

- Air short circuit at indoor unit
- Clogged indoor unit air filter
- Dust accumulation on the indoor unit heat exchanger
- 2/3 way valve closed
- Faulty indoor unit fan motor
- Refrigerant shortage (refrigerant leakage)
- Clogged expansion valve or strainer
- Faulty indoor pipe temperature sensor
- Faulty indoor unit PCB

#### Troubleshooting

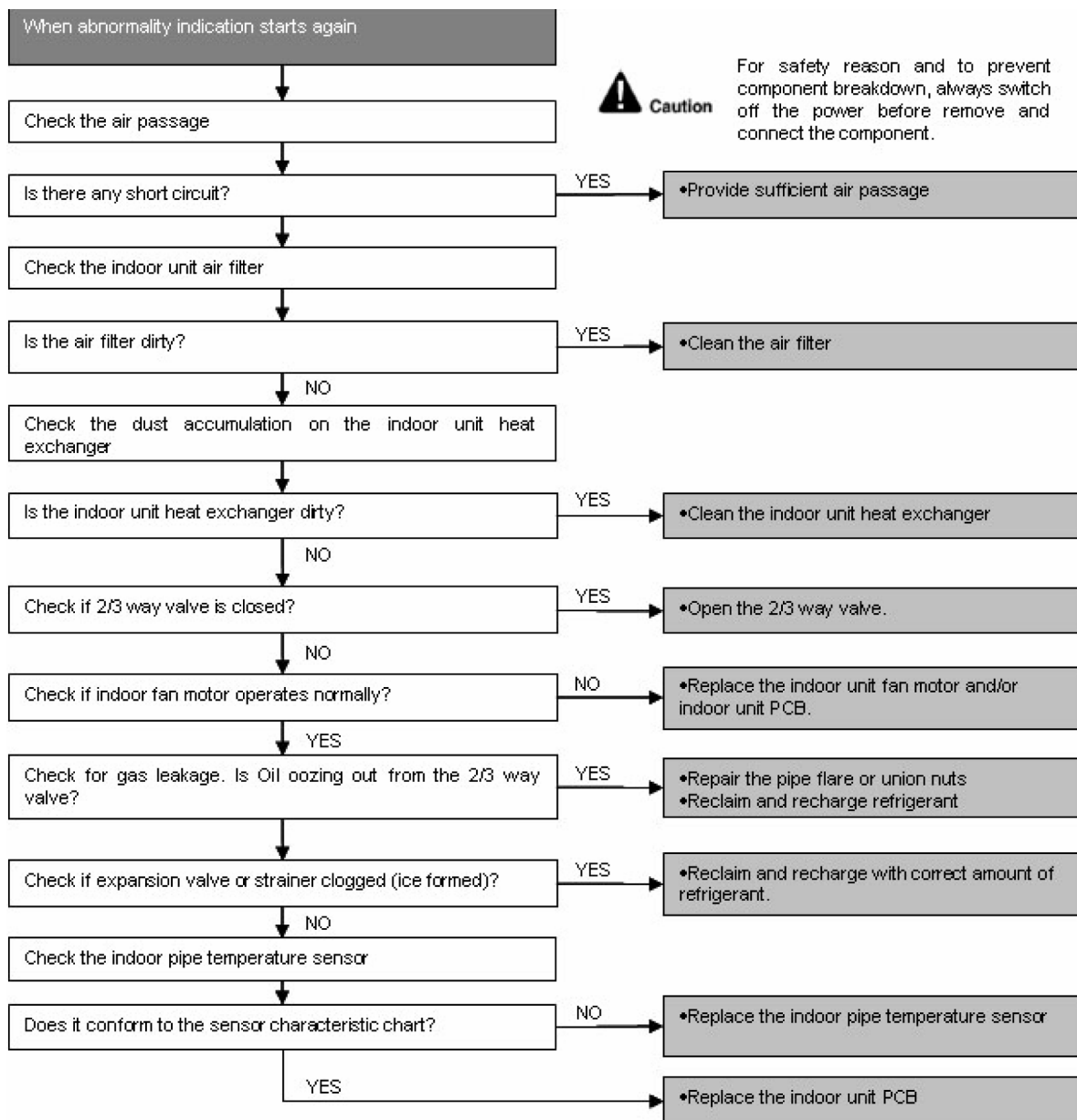

## 15.4.14 F11 (4-way valve Abnormality)

### Malfunction Decision Conditions

- When heating operation, when indoor pipe temperature is below 10°C
- When cooling operation, when indoor pipe temperature is above 45°C

### Malfunction Caused

- Connector in poor contact
- Faulty sensor
- Faulty outdoor unit PCB
- 4-way valve defective

### Troubleshooting

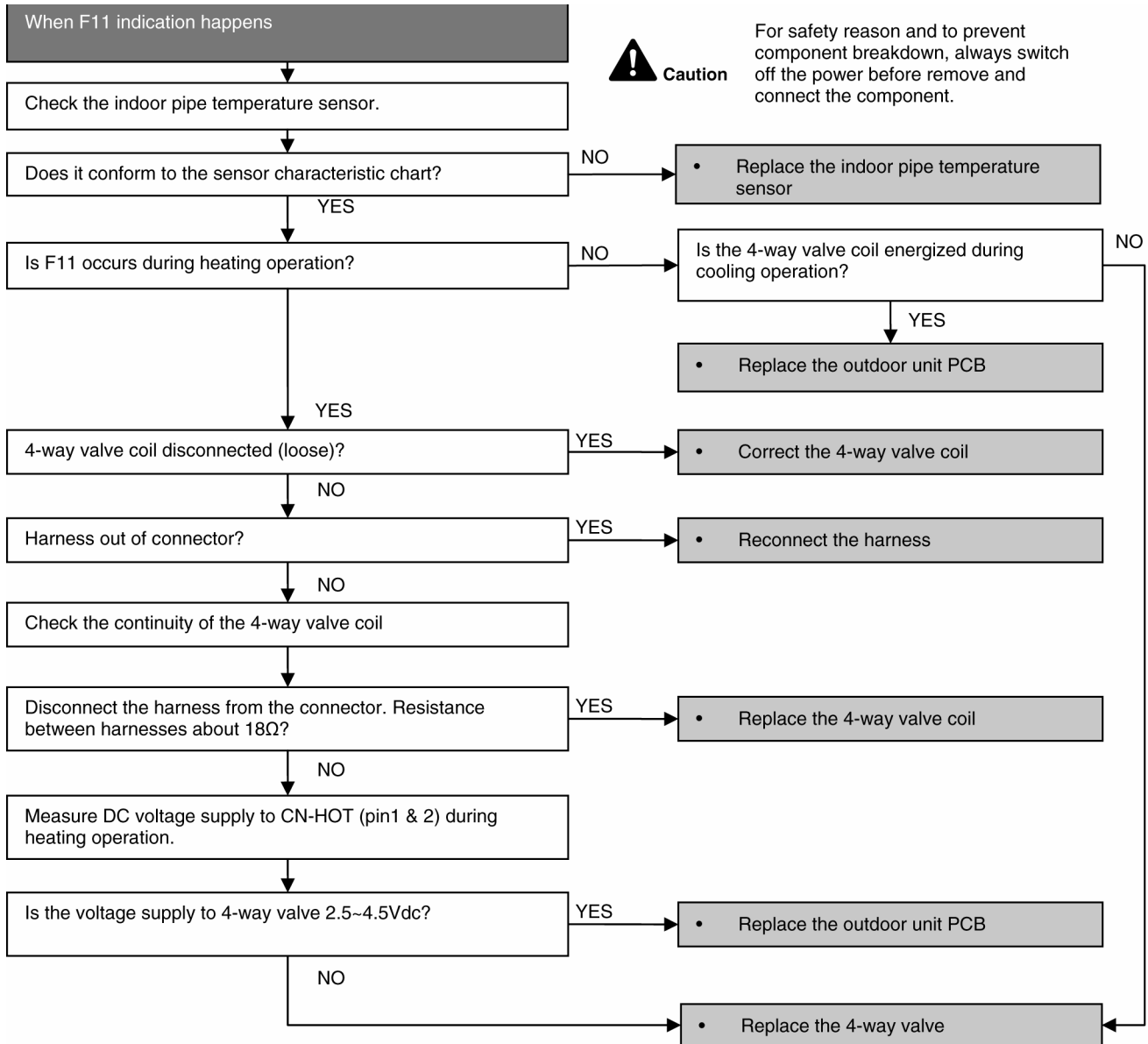



### 15.4.15 F90 (Power Factor Correction Protection)

#### Malfunction Decision Conditions

- During startup and operation of cooling and heating, when Power Factor Correction (PFC) protection circuitry at the outdoor unit main PCB senses abnormal high DC voltage level.

#### Malfunction Caused

- DC voltage peak due to power supply surge.
- DC voltage peak due to compressor windings not uniform.
- Faulty outdoor PCB.

#### Troubleshooting

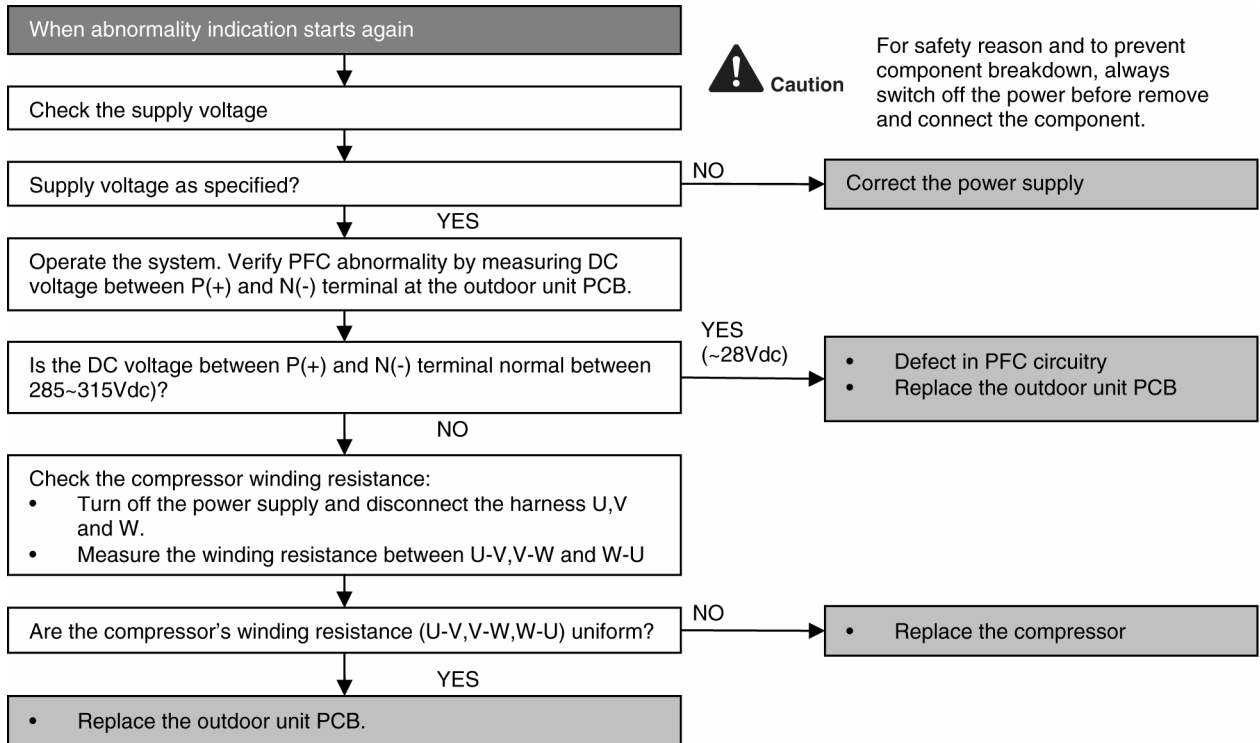

## 15.4.16 F91 (Refrigeration Cycle Abnormality)

### Malfunction Decision Conditions

- During cooling, compressor frequency = F<sub>cmax</sub>.
- During heating, compressor frequency > F<sub>hrated</sub>.
- During cooling and heating operation, running current:  $0.65A < I < 1.65A$ .
- During cooling, indoor intake - indoor pipe < 4°C
- During heating, indoor pipe - indoor intake < 5°C

#### Multi Models Only

- Gas shortage detection 1: A gas shortage is detected by checking the CT-detected input current value and the compressor running frequency. During startup and operating of cooling and heating, input current <  $8.78/256 (A/Hz) \times \text{compressor running frequency} + 0.25$ .
- Gas shortage detection 2: A gas shortage is detected by checking the difference between indoor pipe temperature and indoor intake air temperature during cooling and heating.

### Malfunction Caused

- Faulty indoor intake air or pipe temperature sensor
- 2/3 way valve closed
- Refrigerant shortage (refrigerant leakage)
- Clogged expansion valve or strainer
- Faulty outdoor unit
- Poor compression of compressor

### Troubleshooting

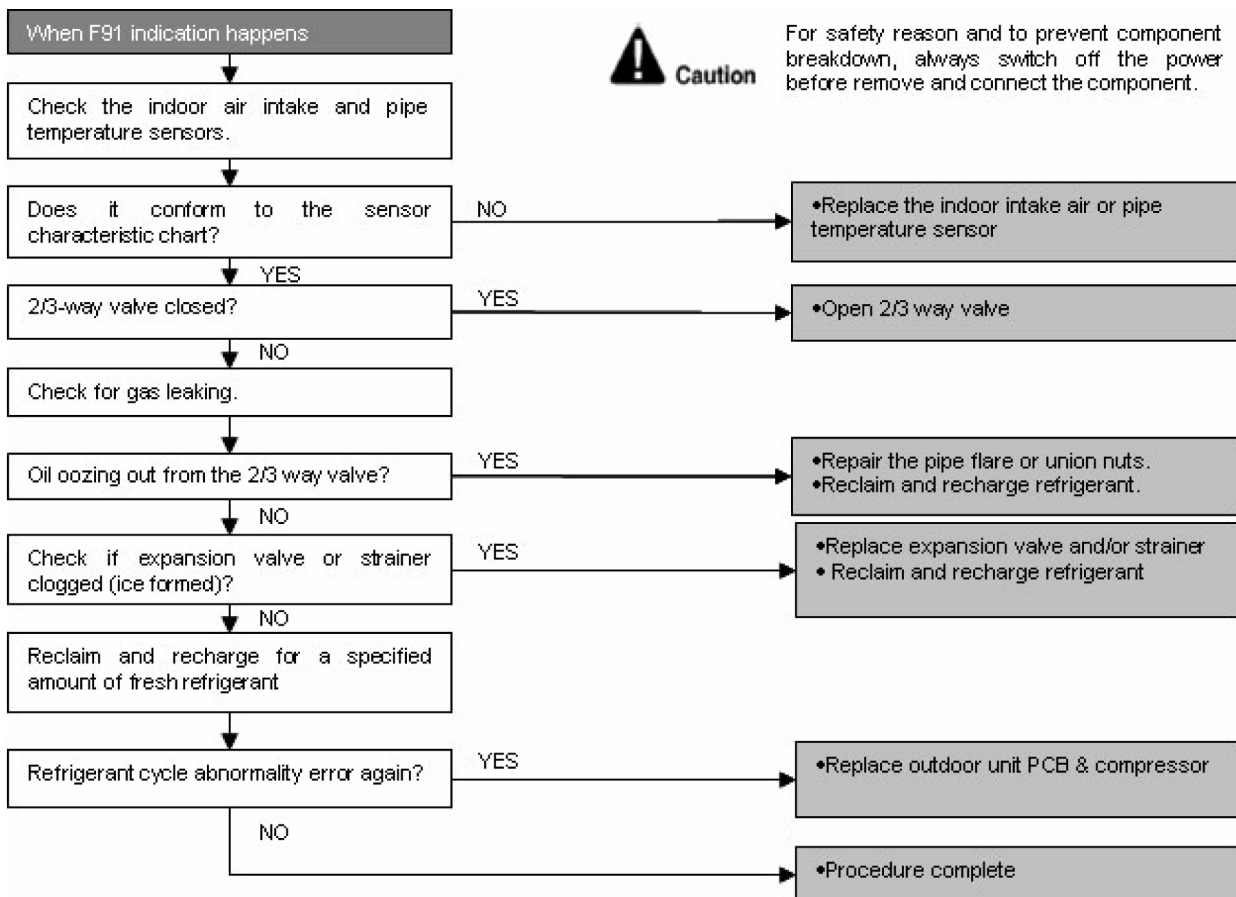

### 15.4.17 F93 (Compressor Rotation Failure)

#### Malfunction Decision Conditions

- A compressor rotation failure is detected by checking the compressor running condition through the position detection circuit.

#### Malfunction Caused

- Compressor terminal disconnect
- Faulty Outdoor PCB
- Faulty compressor

#### Troubleshooting

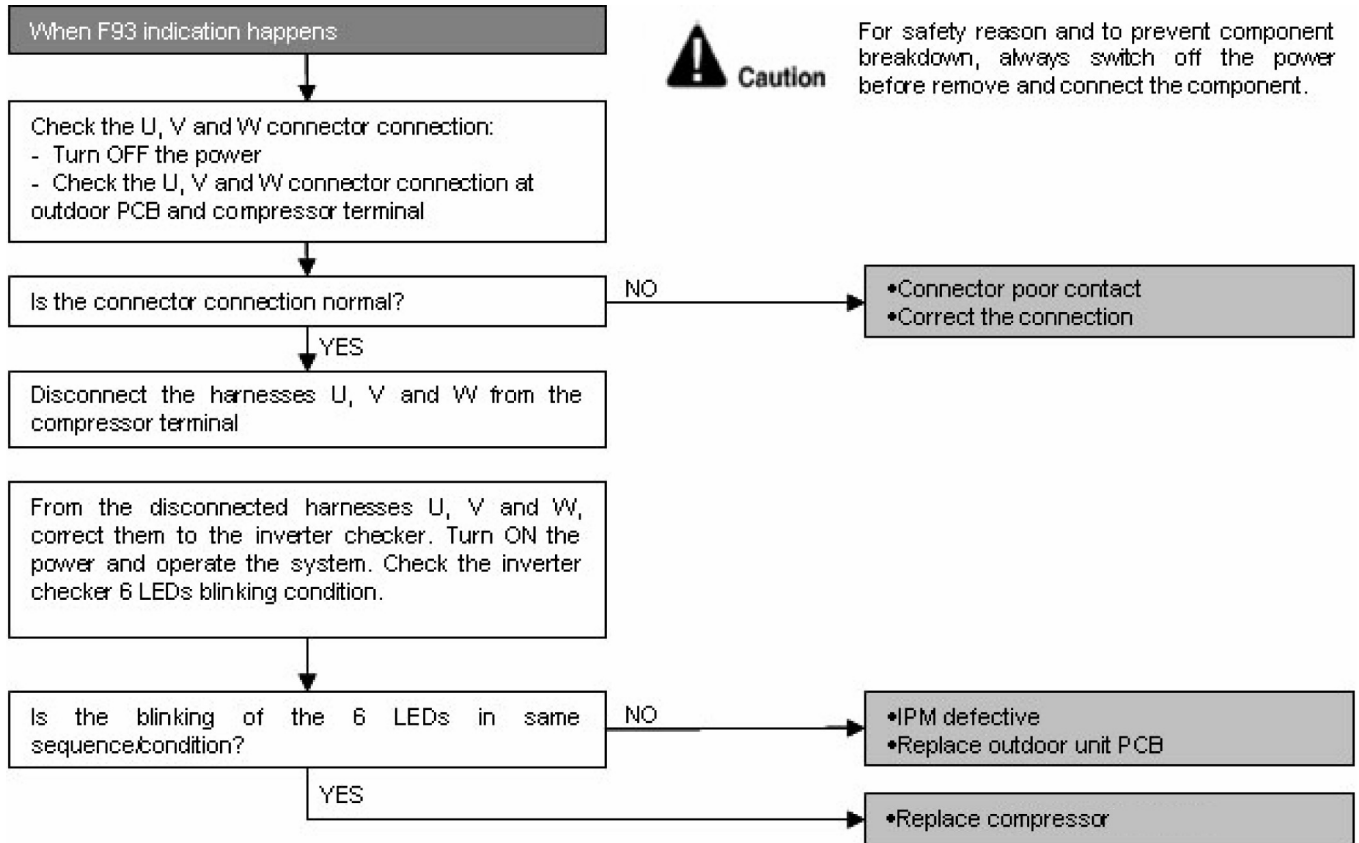

## 15.4.18 F95 (Cooling High Pressure Abnormality)

### Malfunction Decision Conditions

- During operation of cooling, when outdoor unit heat exchanger high temperature data (61°C) is detected by the outdoor pipe temperature sensor.

### Malfunction Caused

- Air short circuit at indoor unit
- Dust accumulation on the indoor unit heat exchanger
- 2/3 way valve closed
- Faulty outdoor unit fan motor
- Excessive refrigerant
- Clogged expansion valve or strainer
- Faulty outdoor pipe temperature sensor
- Faulty outdoor unit PCB

### Troubleshooting

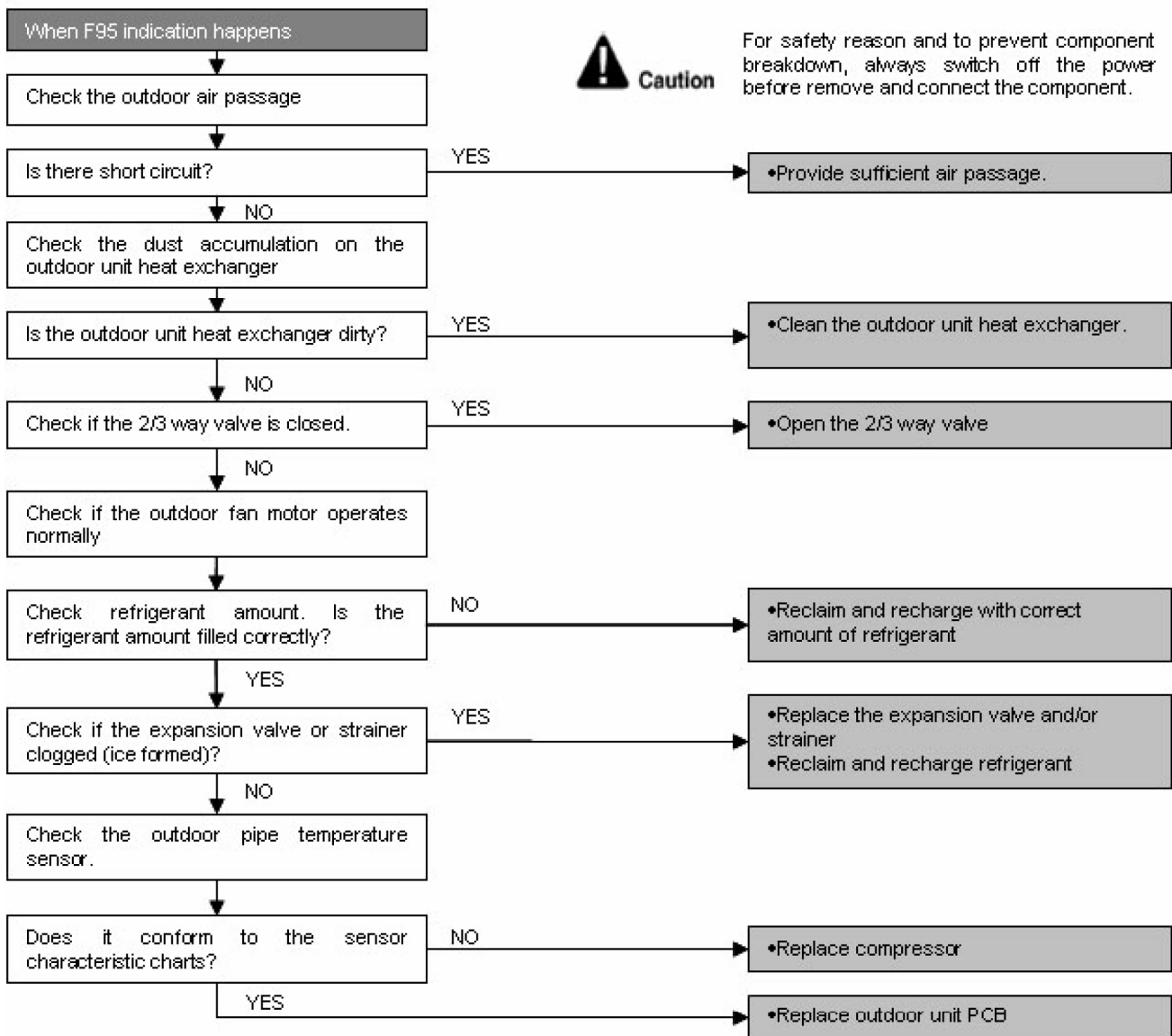

### 15.4.19 F96 (IPM Overheating)

#### Malfunction Decision Conditions

- During operating of cooling and heating, when IPM temperature data (100°C) is detected by the IPM temperature sensor.

*Multi models only*

- Compressor Overheating: During operation of cooling and heating, when the compressor OL is activated.
- Heat Sink Overheating: During operation of cooling and heating, when heat sink temperature data (90°C) is detected by the heat sink temperature sensor.

#### Malfunction Caused

- IPM overheats due to short circuit of hot discharge air flow.
- IPM overheats due to defective of outdoor fan motor.
- IPM overheats due to defective of internal circuitry of IPM.
- IPM overheats due to defective IPM temperature sensor.

*Multi Models Only*

- Compressor OL connector poor contact.
- Compressor OL faulty.

#### Troubleshooting

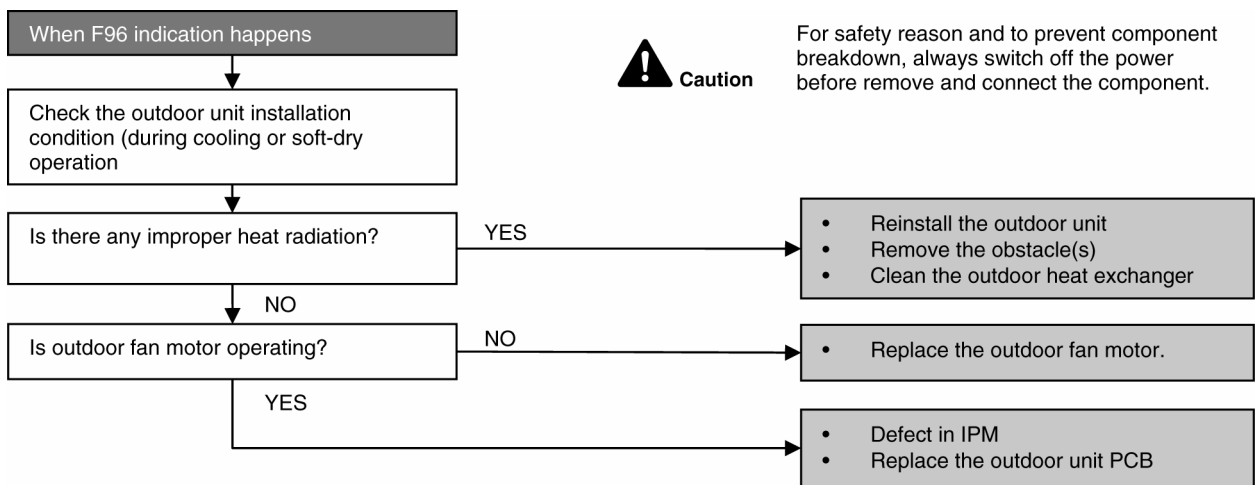

Caution

For safety reason and to prevent component breakdown, always switch off the power before remove and connect the component.

## 15.4.20 F97 (Compressor Overheating)

### Malfunction Decision Conditions

- During operation of cooling and heating, when compressor tank temperature data (112°C) is detected by the compressor tank temperature sensor.

### Malfunction Caused

- Faulty compressor tank temperature sensor
- 2/3 way valve closed
- Refrigerant shortage (refrigerant leakage)
- Faulty outdoor unit PCB
- Faulty compressor

### Troubleshooting

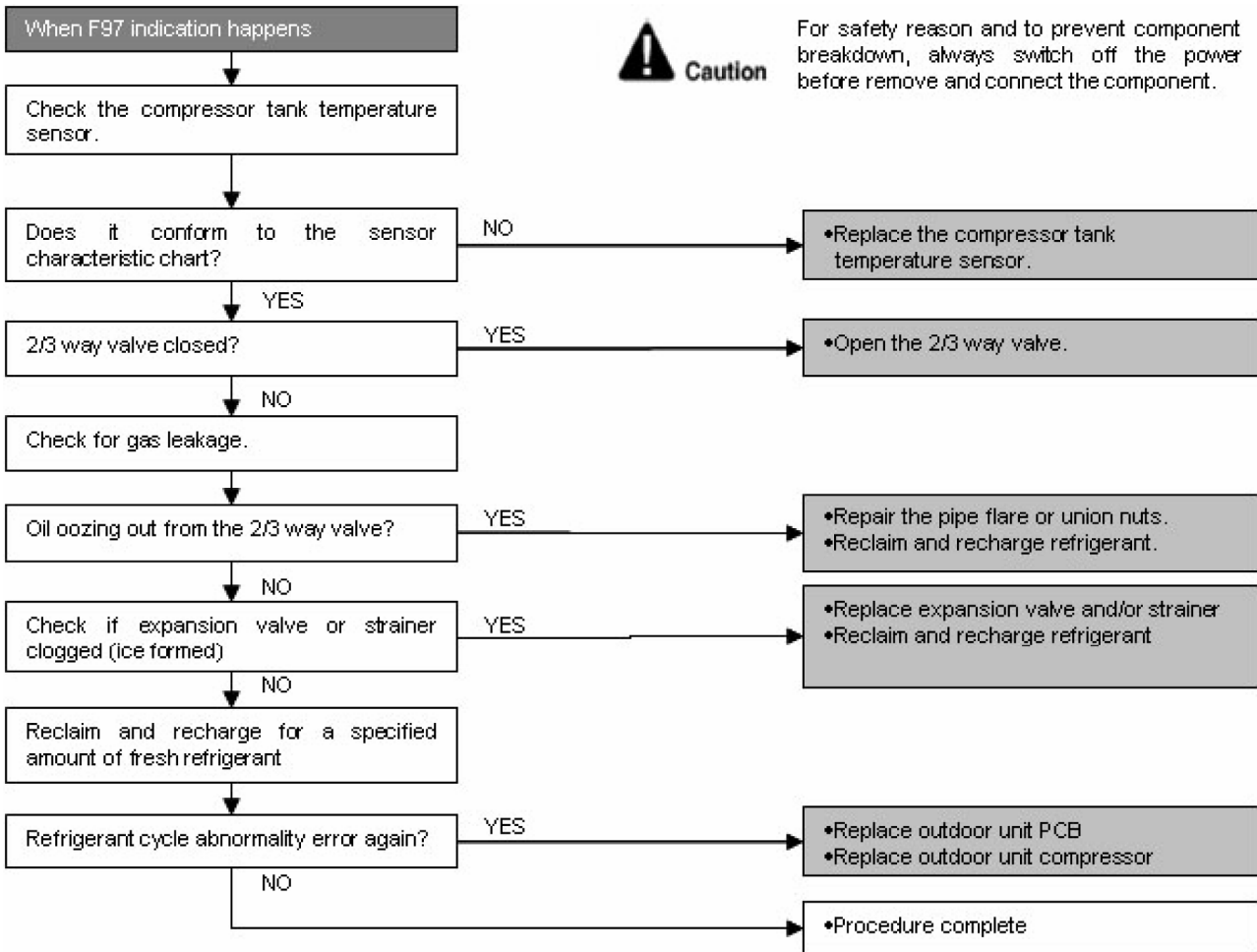

## 15.4.21 F98 (Input Over Current Detection)

### Malfunction Decision Conditions

- During operation of cooling and heating, when an input over-current (X value in Total Running Current Control) is detected by checking the input current value being detected by current transformer (CT) with the compressor running.

### Malfunction Caused

- Excessive refrigerant.
- Faulty outdoor unit PCB.

### Troubleshooting

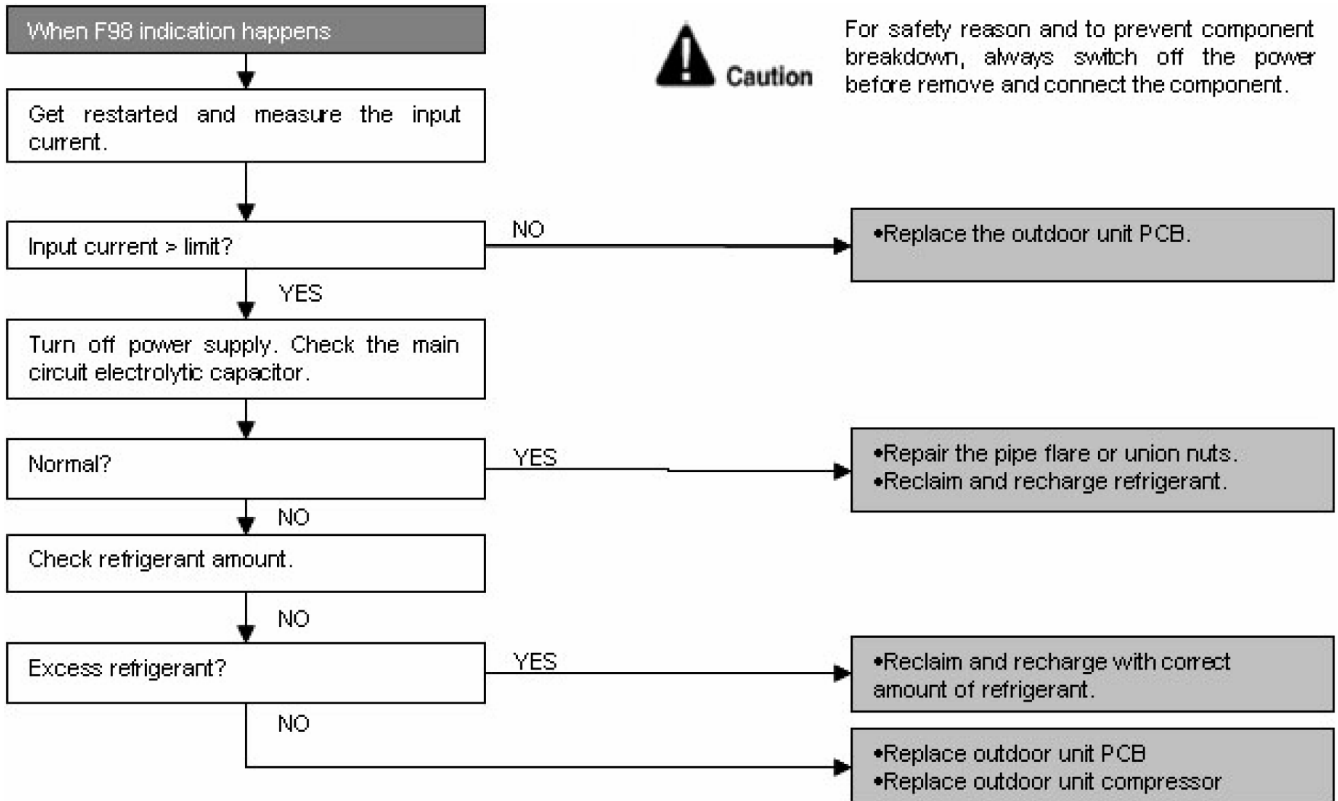

## 15.4.22 F99 (Output Over Current Detection)

### Malfunction Decision Conditions

- During operation of cooling and heating, when an output over-current (DC peak current value at IPM Prevention Control) is detected by checking the current that flows in the inverter DC peak sensing circuitry.

### Malfunction Caused

- Faulty outdoor unit PCB
- Faulty compressor

### Troubleshooting

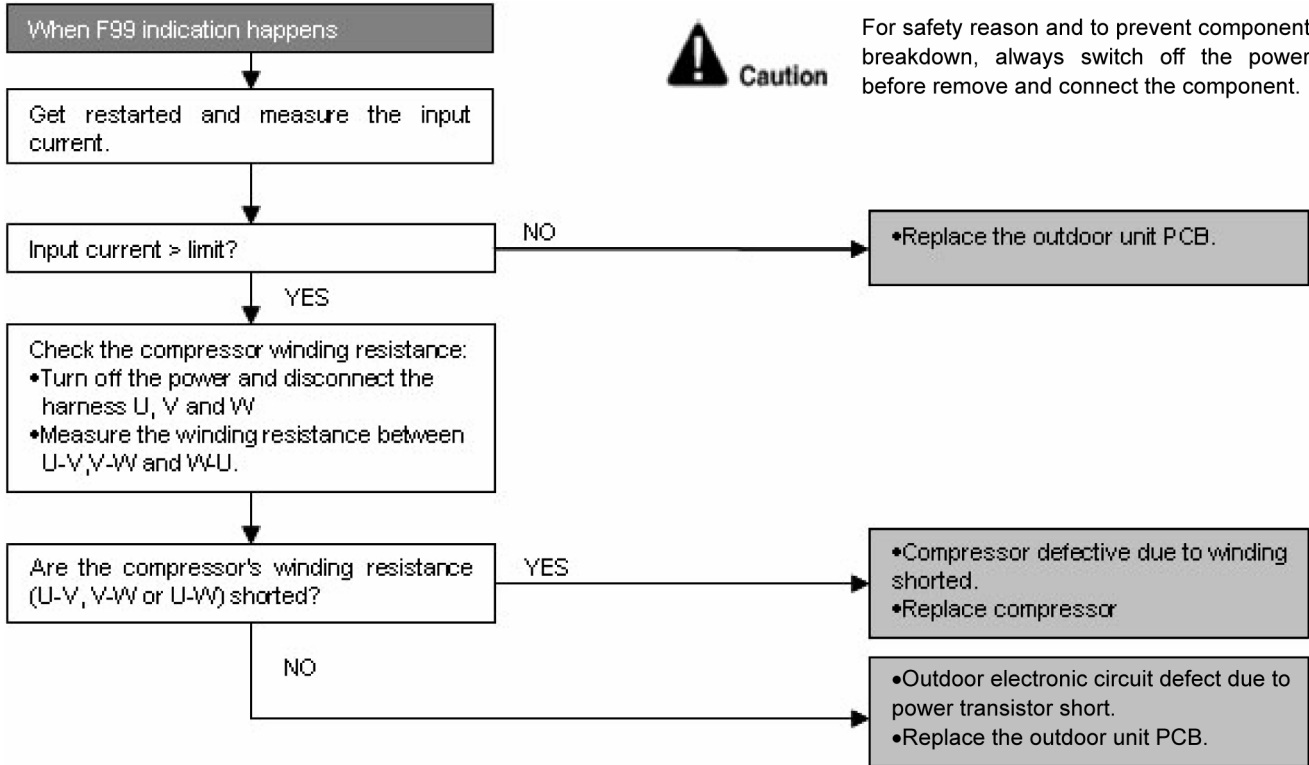

- Checking the power transistor.
- Never touch any live parts for at least 10 minutes after turning off the circuit breaker.
- If unavoidable necessary to touch a live part, make sure the power transistor's supply voltage is below 50V using the tester.
- For the UVW, make measurement at the Faston terminal on the board of the relay connector.

Tester's negative terminal	Power transistor (+)	UVW	Power transistor (-)	UVW
Tester's positive terminal	UVW	Power transistor (+)	UVW	Power transistor (-)
Normal resistance	Several kΩ to several MΩ			
Abnormal resistance	0 or ∞			



## 16. Disassembly and Assembly Instructions



**WARNING**

High voltages are generated in the electrical parts area by the capacitor. Ensure that the capacitor has discharged sufficiently before proceeding with repair work. Failure to heed this caution may result in electric shocks.

### 16.1 Indoor Electronic Controllers, Cross Flow Fan and Indoor Fan Motor Removal Procedures

#### 16.1.1 To remove front grille

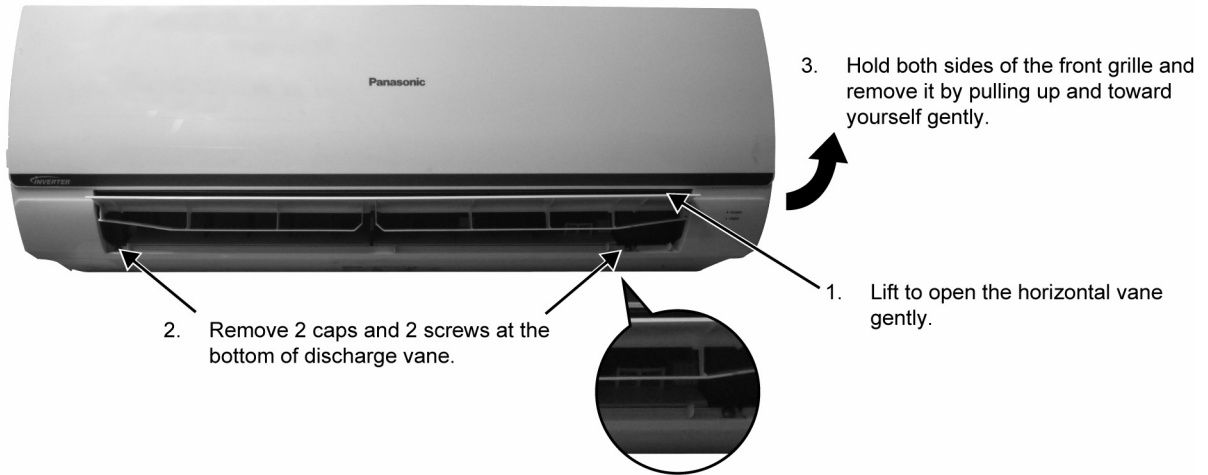

Figure 1

#### 16.1.2 To remove electronic controller



Figure 2

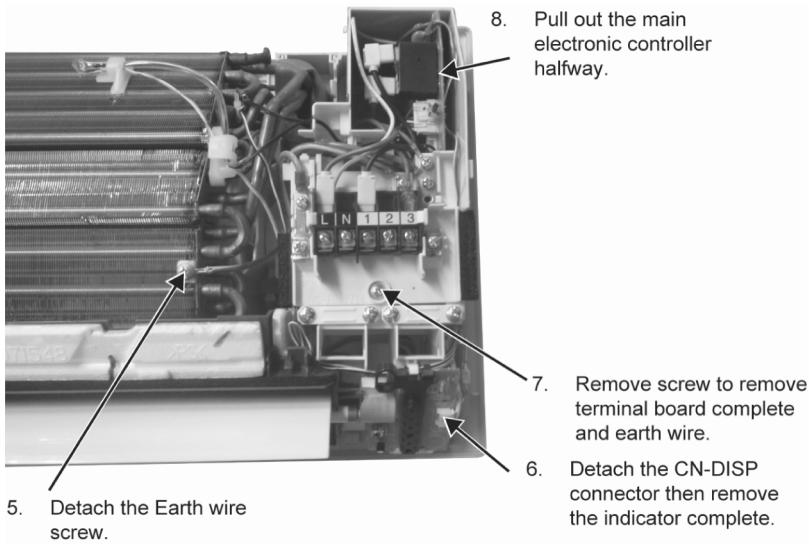

Figure 3

9. Detach connectors as labeled from the electronic controller. Then pull out main controller gently.

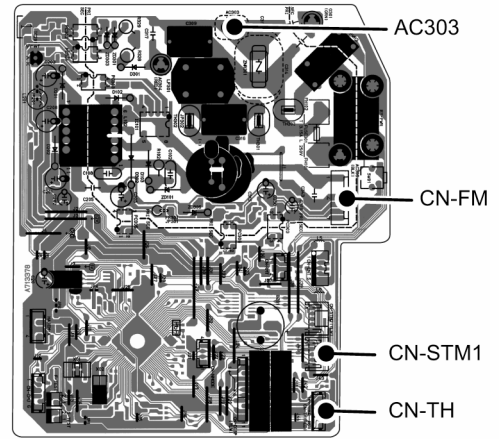

Figure 4

### 16.1.3 To remove discharge grille

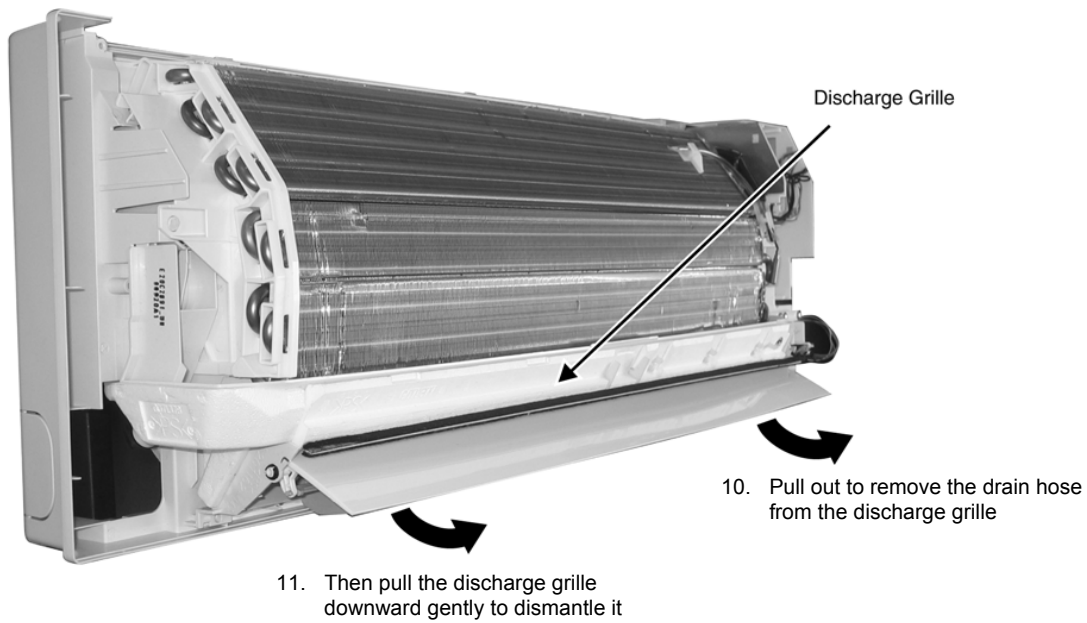

Figure 5

### 16.1.4 To remove control board

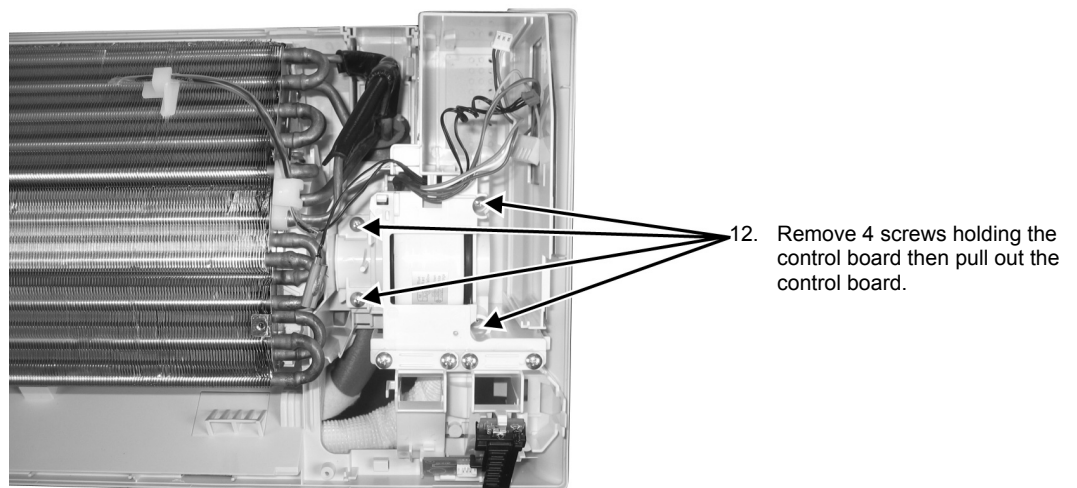

Figure 6

### 16.1.5 To remove cross flow fan and indoor fan motor

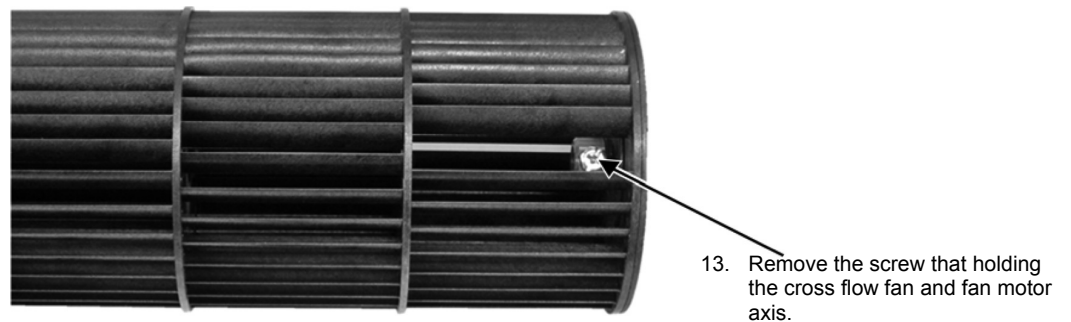

Figure 7

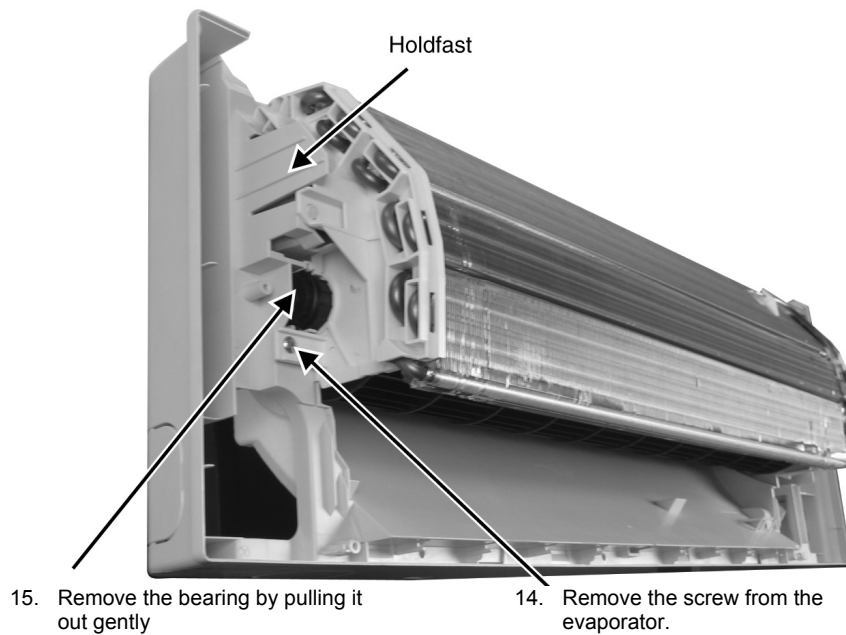
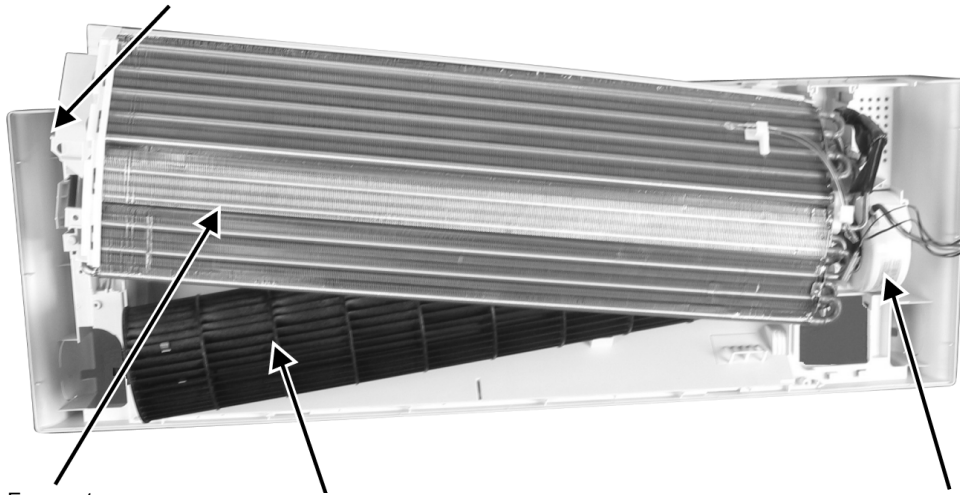

Figure 8

16. Push the holdfast to the left and lift up the evaporator.



Evaporator

17. Remove the cross flow fan from the unit by pulling it to the left and downward.

18. Fan motor can be removed after the removal of cross flow fan.

Reminder: To reinstall the fan motor, adjust the fan motor connector to 45° towards you before fixing control board.

**Figure 9**

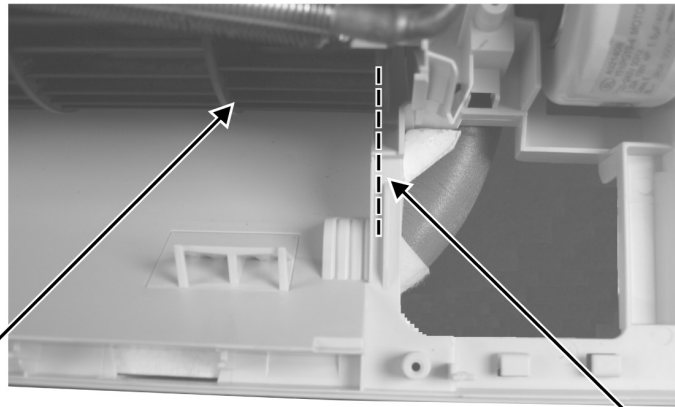

Cross Flow Fan

Reminder: To reinstall the cross flow fan, ensure cross flow fan is in line as shown in figure 10

**Figure 10**

## 16.2 Outdoor Electronic Controller Removal Procedure

**⚠ Caution!** When handling electronic controller, be careful of electrostatic discharge.

1 Remove the 5 screws of the Top Panel.

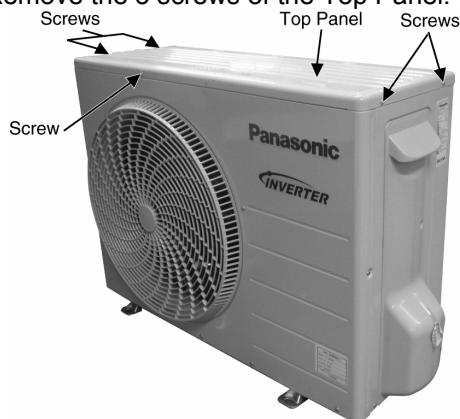

Fig.1

2 Remove the 8 screws of the Front Panel.

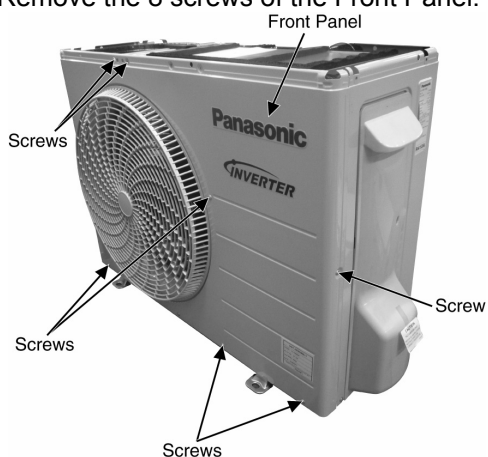

Fig.2

3 Remove the screw of the Terminal Board Cover.

4 Remove the Top Cover of the Control Board by 4 hooks.

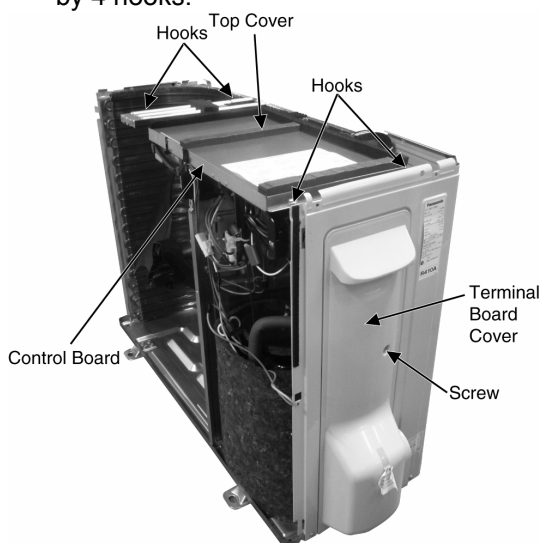

Fig.3

5 Remove the Control Board as follows:

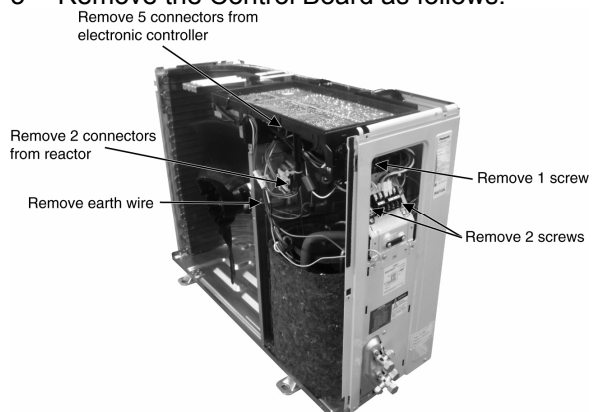

Fig.4

Remove the Terminal Cover and 3 Terminal Compressor

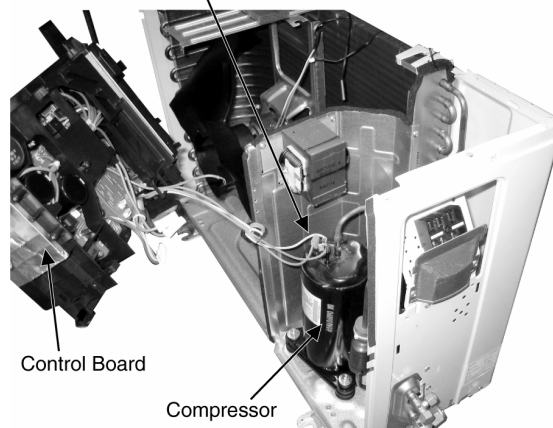

Fig.5

Electronic Controller Control Board

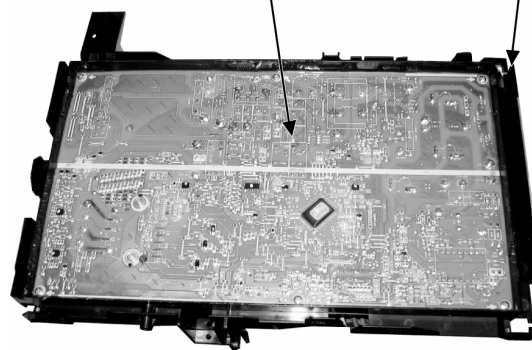

Fig.6

# 17. Technical Data

## 17.1 Operation Characteristics

### 17.1.1 CU-CE9NKE

#### • Cooling Characteristic

[Condition] Indoor temperature: 27/19°C

Remote condition: High fan speed, Cool 16°C

Comp. Hz: Rated F<sub>c</sub>

Voltage: 230V

Pipe Length: 5.0m

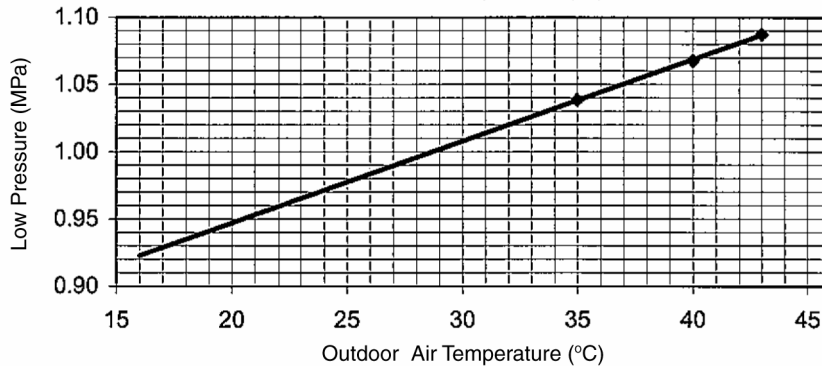
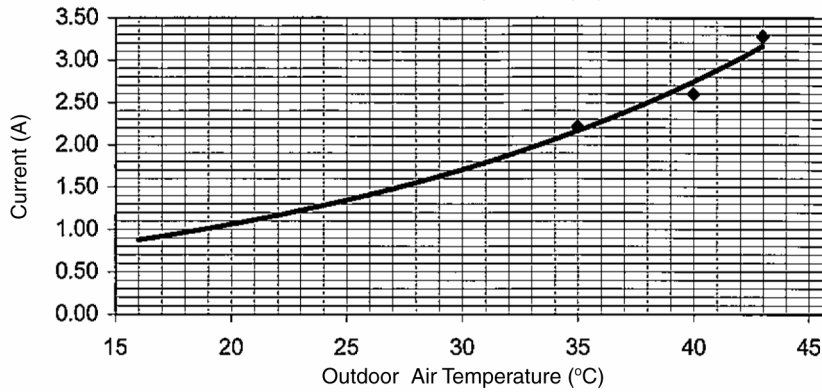
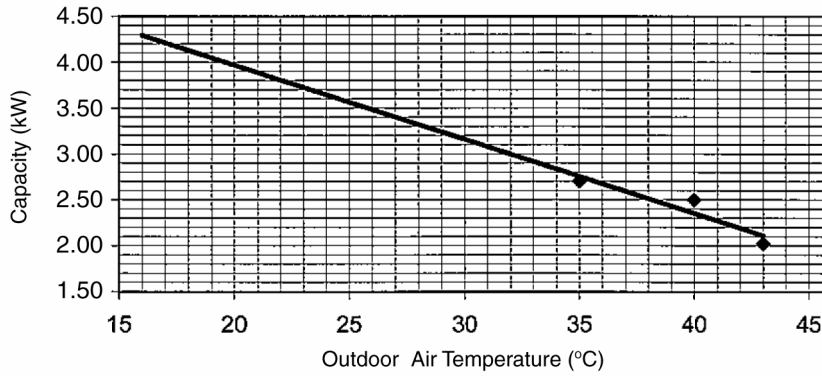
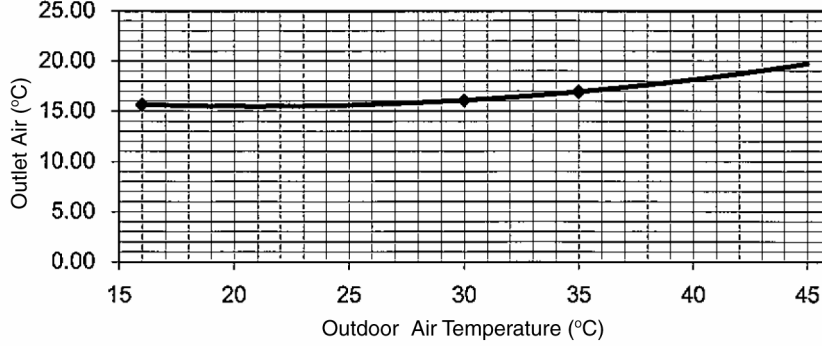

## • Piping Length Characteristic

[Condition] Indoor temperature: 27/19°C, Outdoor temperature: 35/24°C  
 Remote condition: High fan speed, Cool 16°C  
 Comp. Hz: Rated F<sub>c</sub>  
 Voltage: 230V

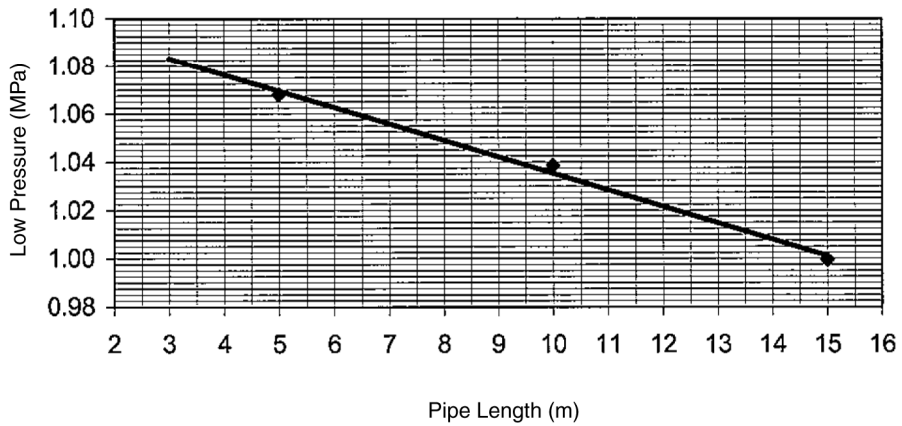
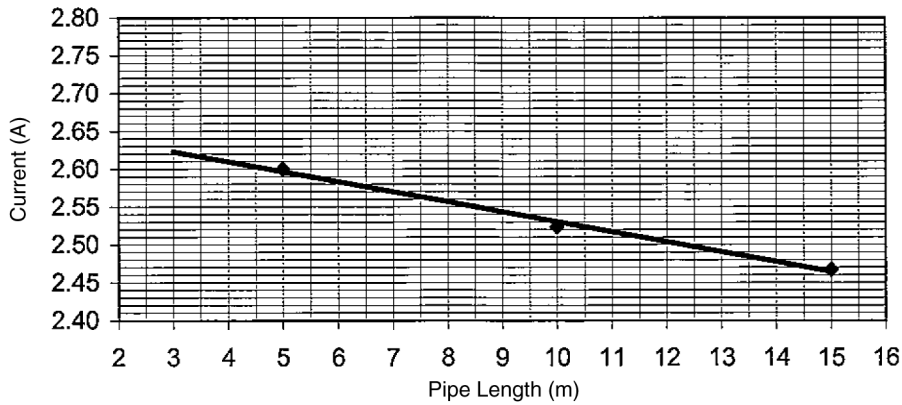
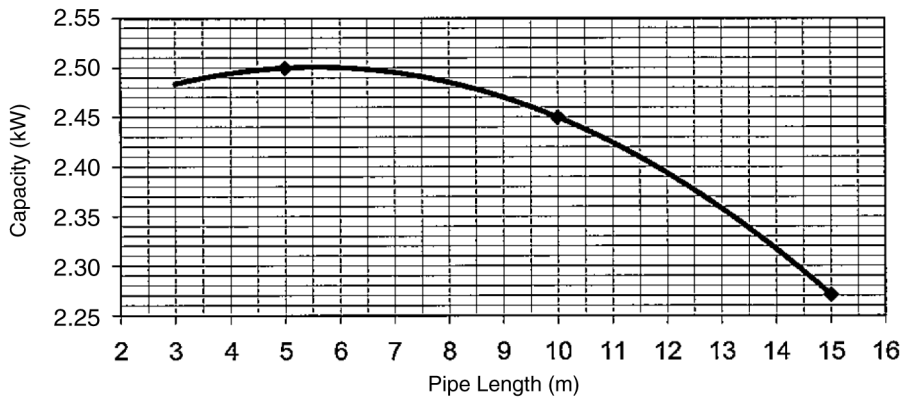
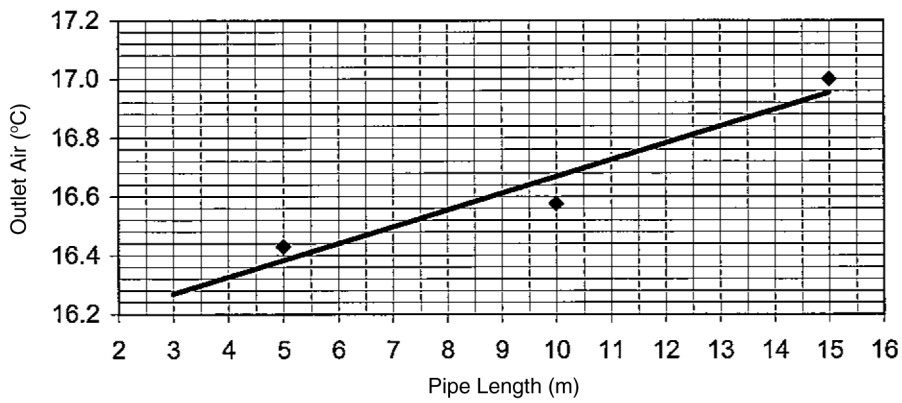

# • Heating Characteristic

[Condition] Indoor temperature: 20/-°C  
Remote condition: High fan speed, Heat 30°C  
Comp. Hz: Rated  $F_h$   
Voltage: 230V  
Pipe Length: 5.0m

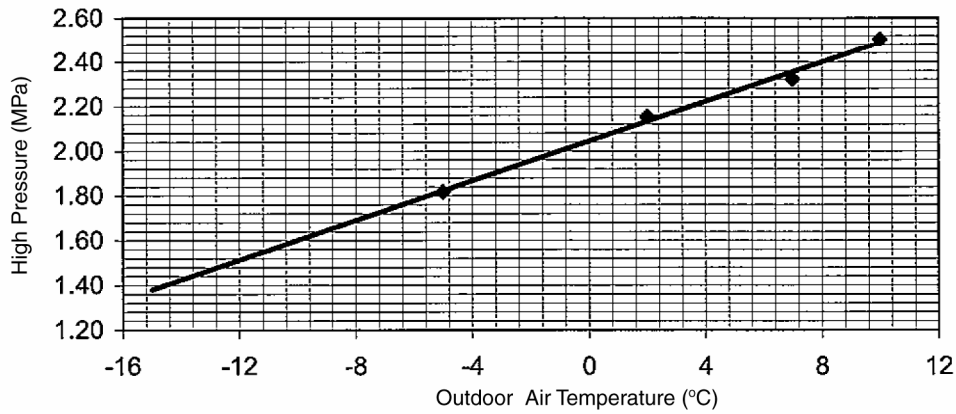
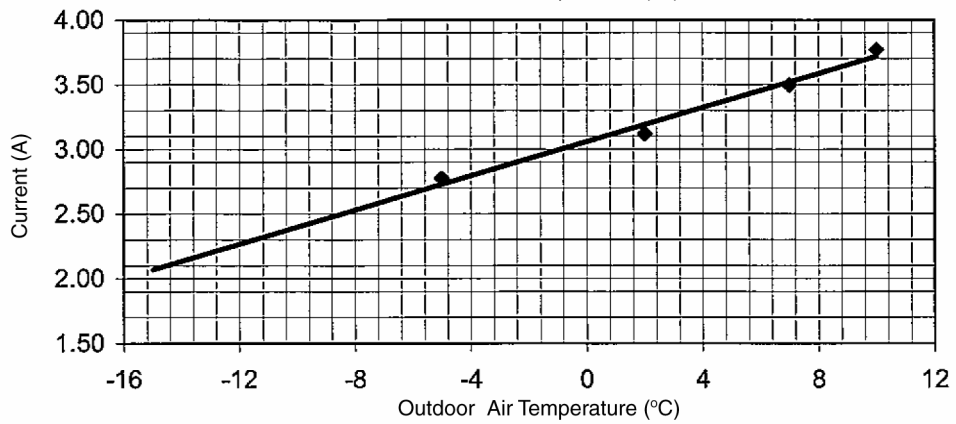
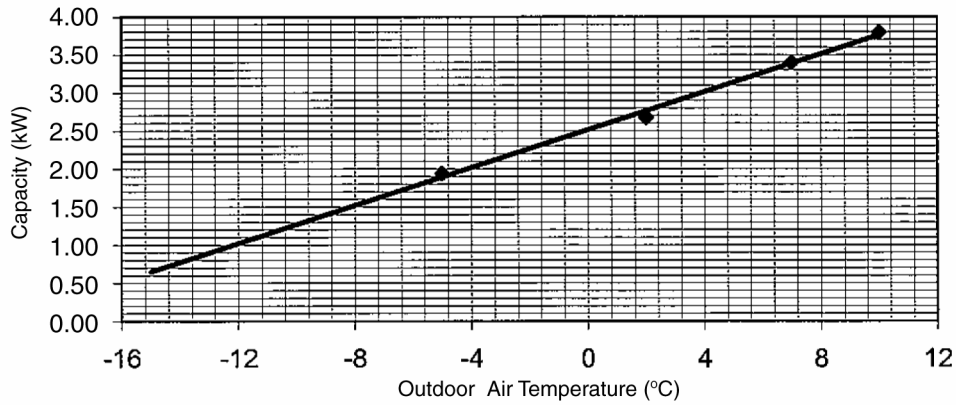
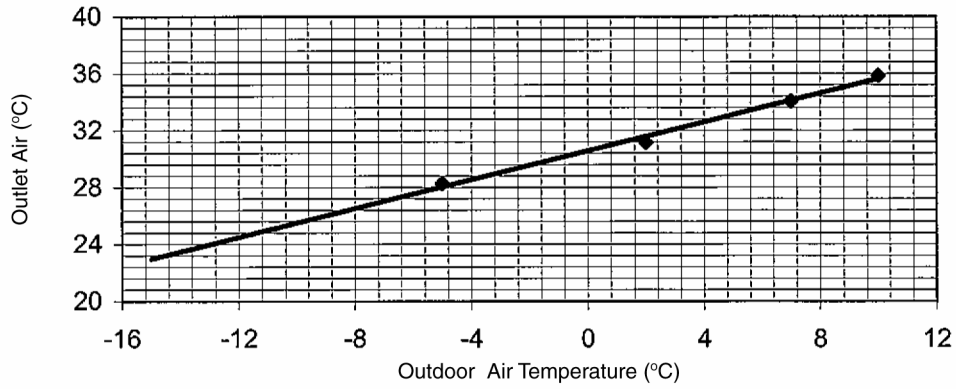



## • Piping Length Characteristic

[Condition] Indoor temperature: 20/-°C, Outdoor temperature: 7/6°C  
 Remote condition: High fan speed, Heat 30°C  
 Comp. Hz: Rated  $F_h$   
 Voltage: 230V

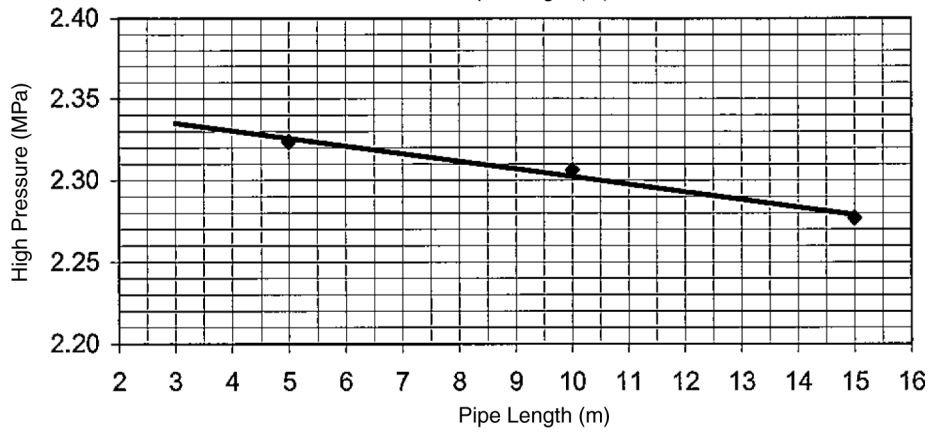
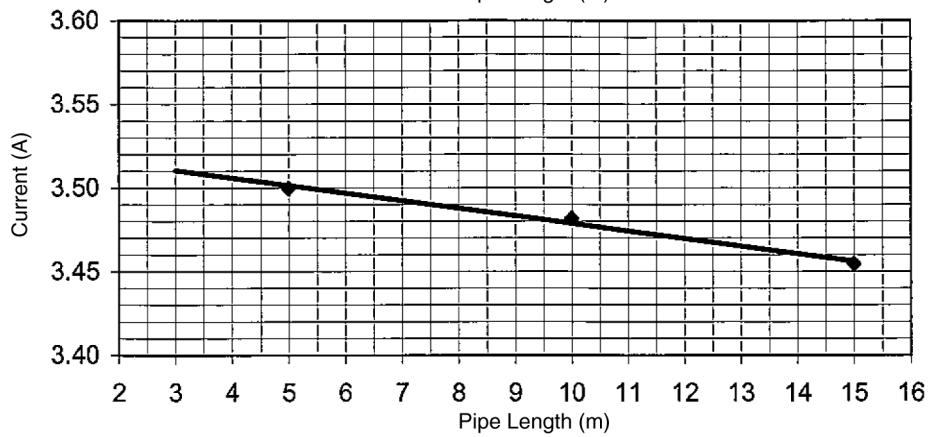
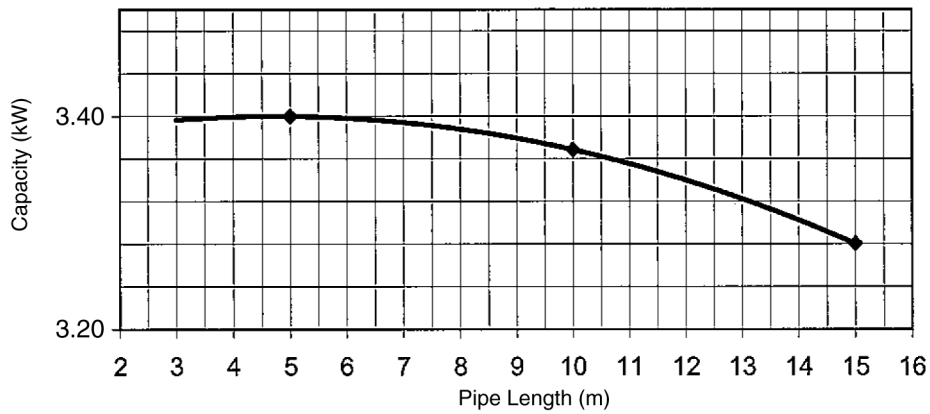
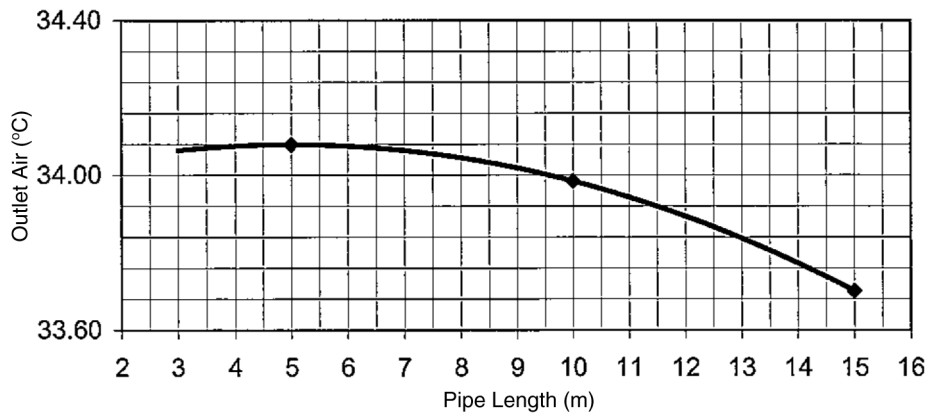

## 17.1.2 CU-CE12NKE

### • Cooling Characteristic

[Condition] Indoor temperature: 27/19°C  
Remote condition: High fan speed, Cool 16°C  
Comp. Hz: Rated F<sub>c</sub>  
Voltage: 230V  
Pipe Length: 5.0m

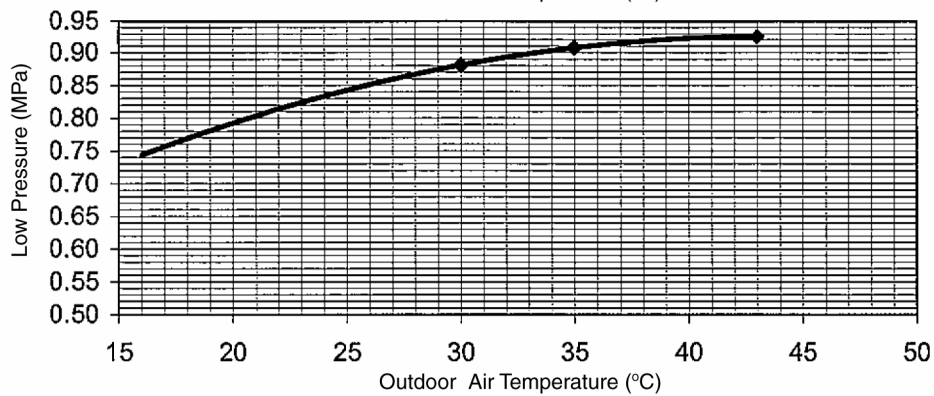
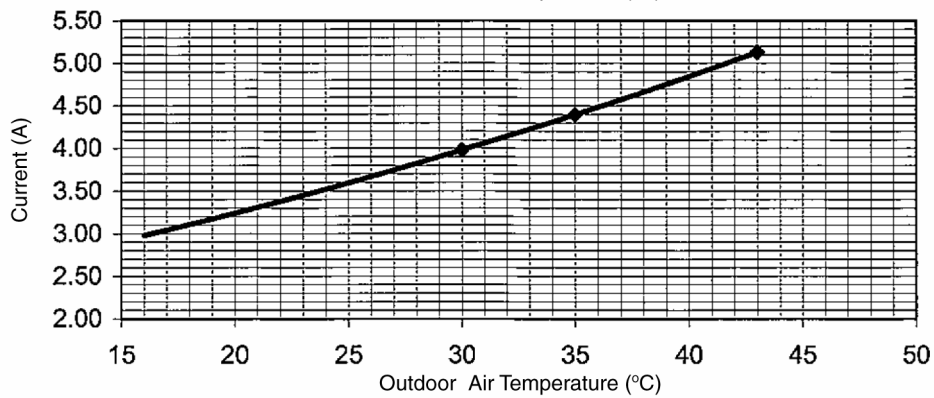
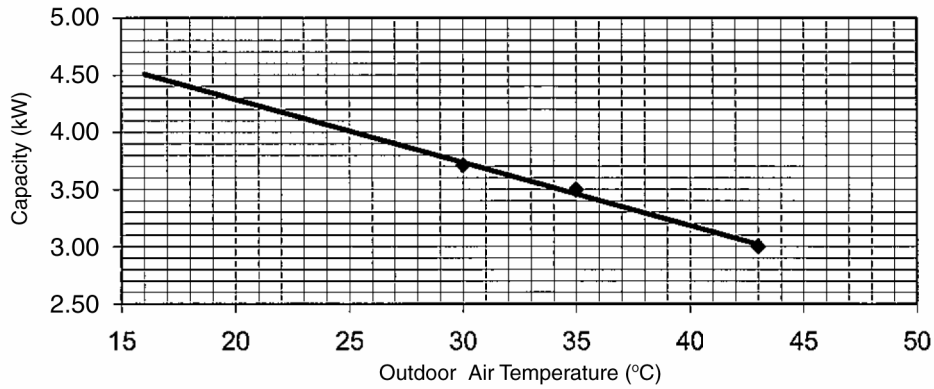
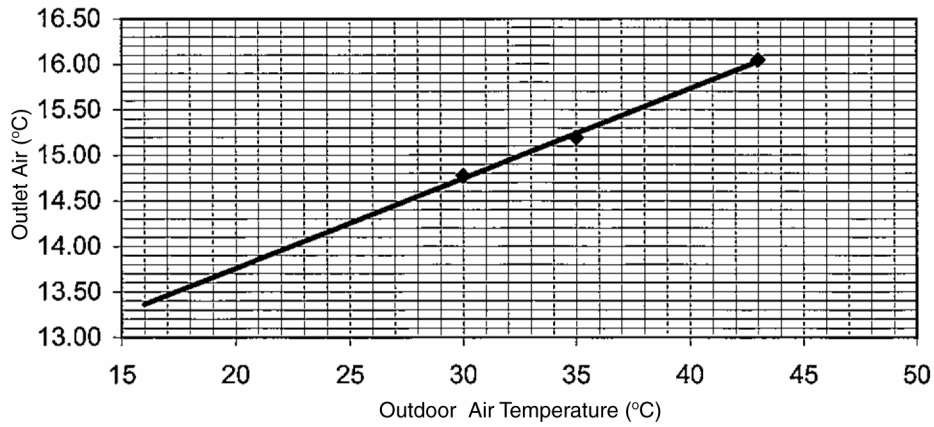

## • Piping Length Characteristic

[Condition] Indoor temperature: 27/19°C, Outdoor temperature: 35/24 °C  
 Remote condition: High fan speed, Cool 16°C  
 Comp. Hz: Rated F<sub>c</sub>  
 Voltage: 230V

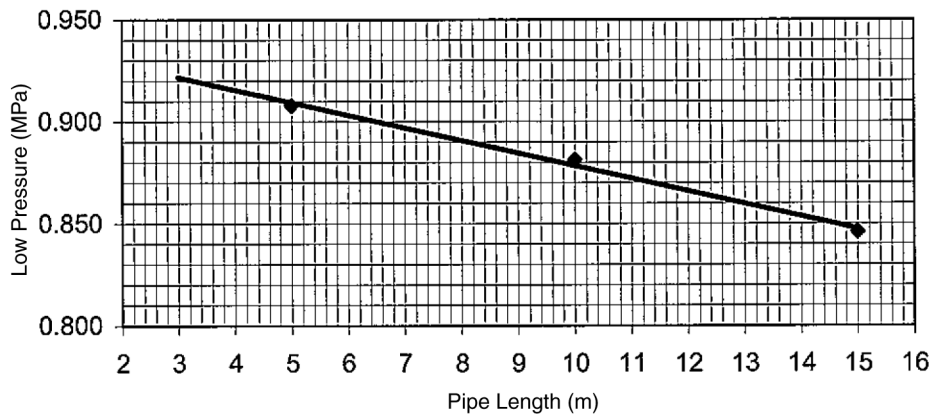
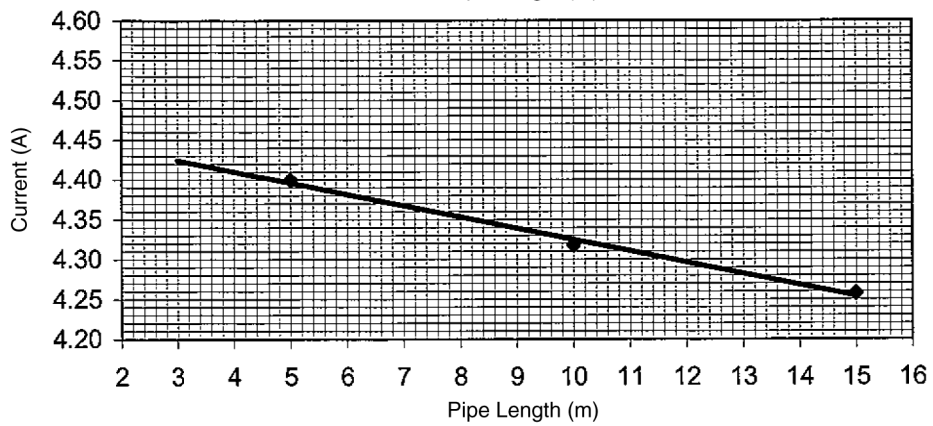
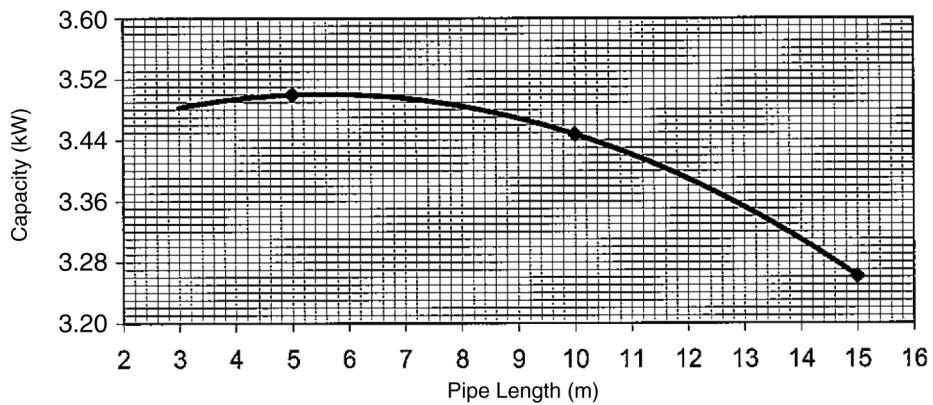
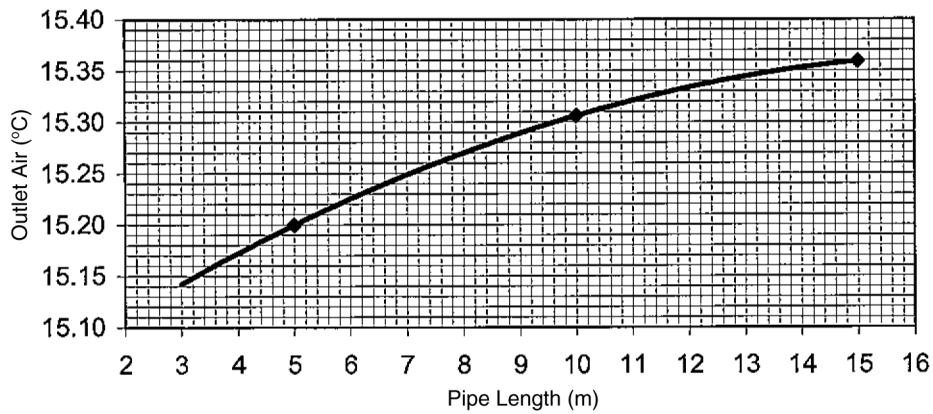

# Heating Characteristic

[Condition] Indoor temperature: 20/-°C  
Remote condition: High fan speed, Heat 30°C  
Comp. Hz: Rated  $F_h$   
Voltage: 230V  
Pipe Length: 5.0m

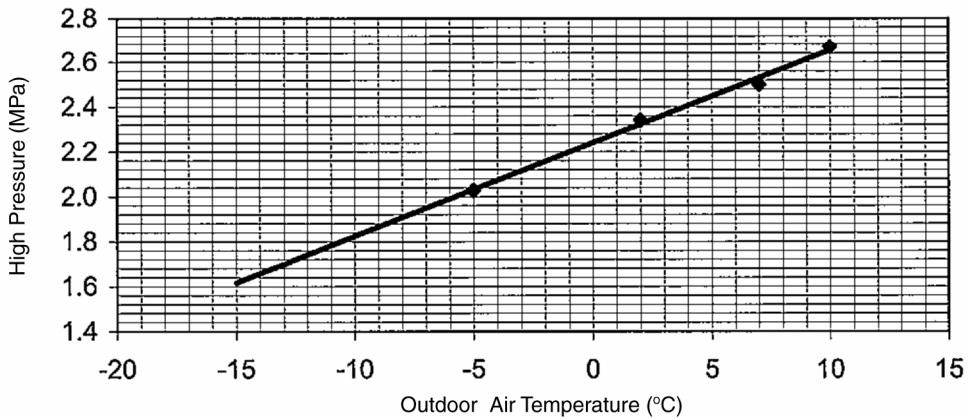
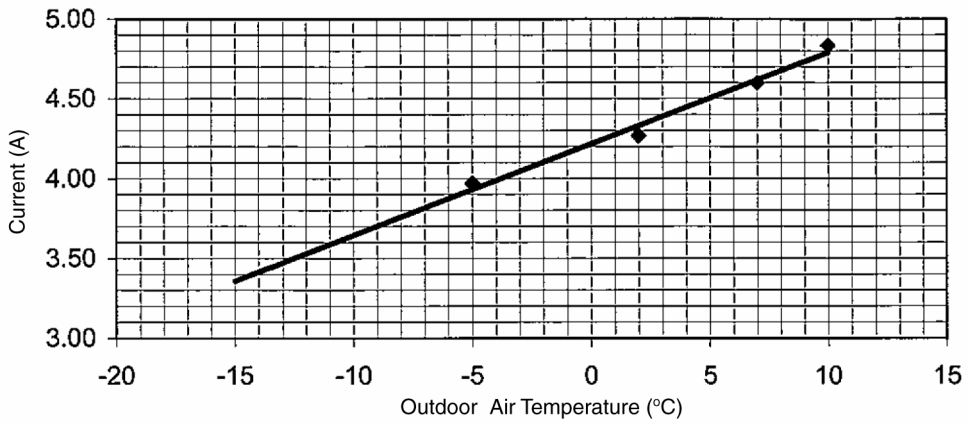
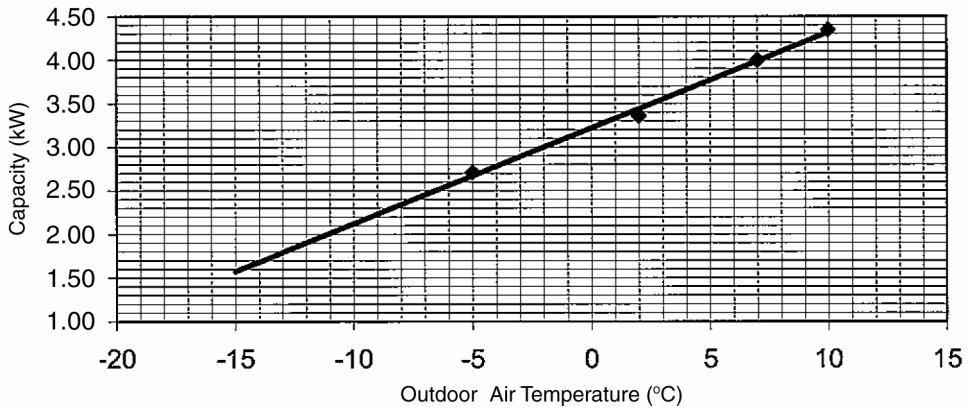
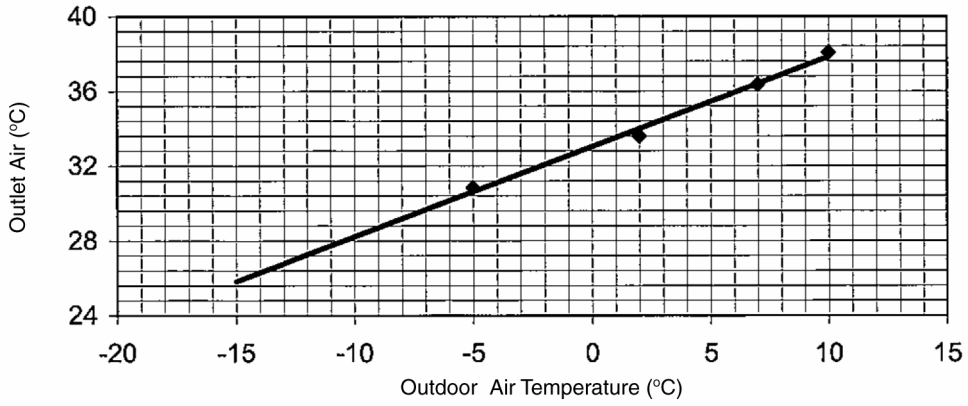

# • Piping Length Characteristic

[Condition] Indoor temperature: 20/-°C, Outdoor temperature: 7/6°C  
 Remote condition: High fan speed, Heat 30°C  
 Comp. Hz: Rated F<sub>h</sub>  
 Voltage: 230V

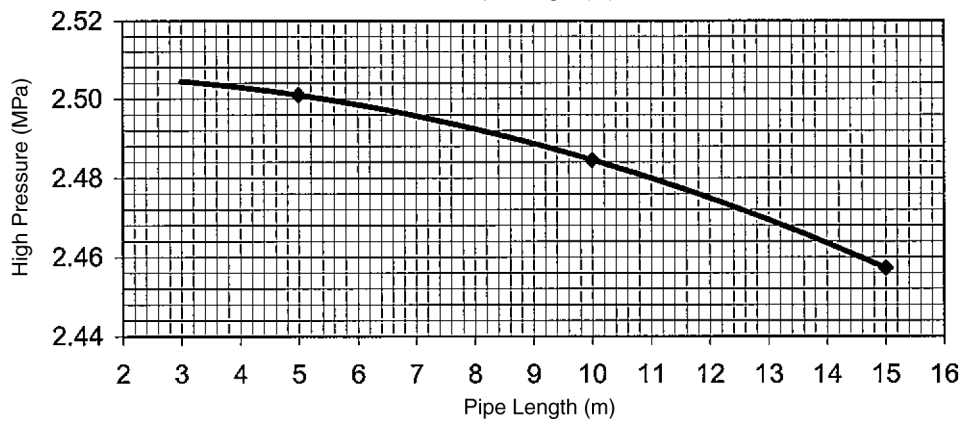
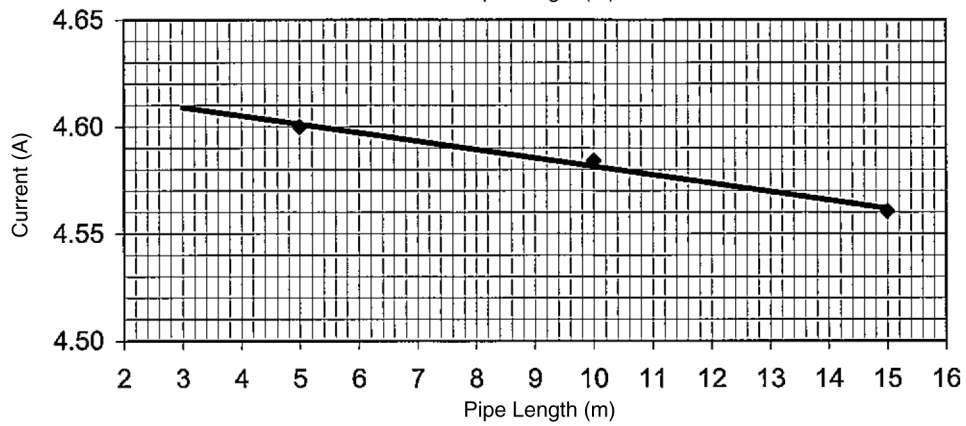
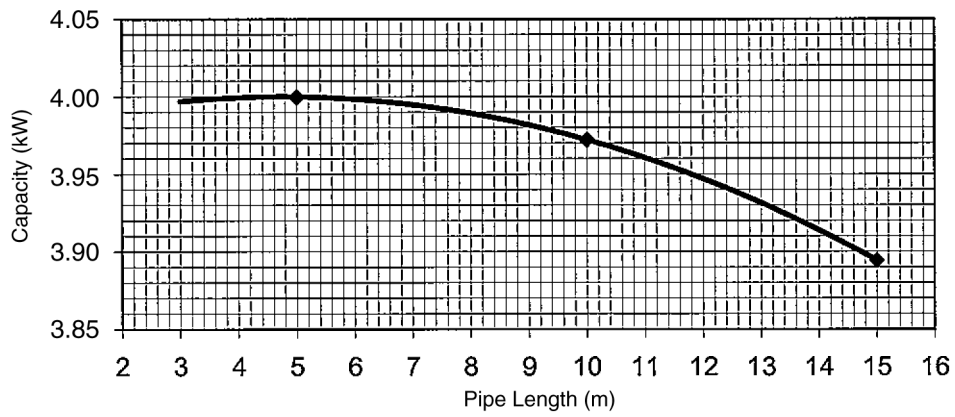
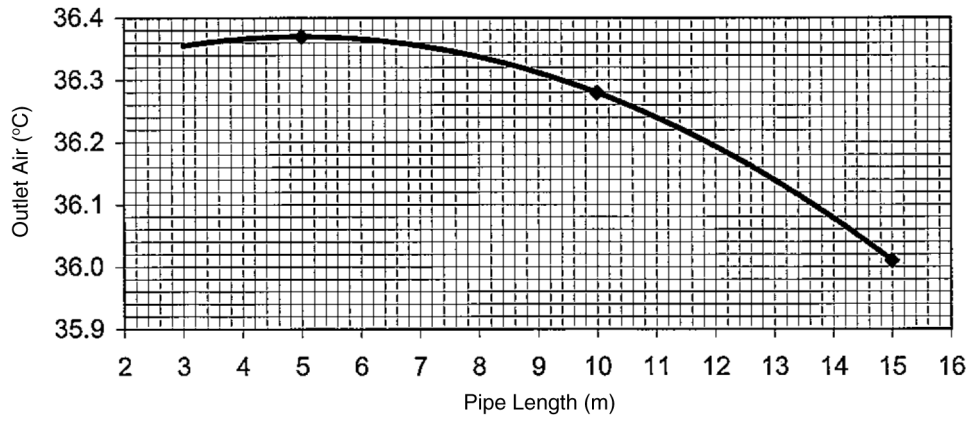

## 17.2 Sensible Capacity Chart

- **CU-CE9NKE**

230V	Outdoor Temp. (°C)											
	30			35			40			46		
Indoor wet bulb temp.	TC	SHC	IP	TC	SHC	IP	TC	SHC	IP	TC	SHC	IP
17.0°C	2.48	1.88	0.50	2.32	1.80	0.54	2.16	1.73	0.57	1.96	1.65	0.62
19.0°C				2.50		0.55						
19.5°C	2.72	1.97	0.51	2.55	1.89	0.55	2.37	1.82	0.59	2.15	1.73	0.63
22.0°C	2.97	2.04	0.52	2.77	1.96	0.56	2.58	1.89	0.60	2.35	1.81	0.64

- **CU-CE12NKE**

230V	Outdoor Temp. (°C)											
	30			35			40			46		
Indoor wet bulb temp.	TC	SHC	IP	TC	SHC	IP	TC	SHC	IP	TC	SHC	IP
17.0°C	3.47	2.63	0.87	3.24	2.52	0.94	3.02	2.43	1.00	2.74	2.30	1.08
19.0°C				3.50		0.95						
19.5°C	3.81	2.76	0.89	3.56	2.65	0.95	3.31	2.55	1.02	3.01	2.43	1.10
22.0°C	4.15	2.86	0.90	3.88	2.75	0.97	3.61	2.65	1.04	3.28	2.53	1.12

TC - Total Cooling Capacity (kW)  
 SHC - Sensible Heat Capacity (kW)  
 IP - Input Power (kW)  
 Indoor 27°C/19°C  
 Outdoor 35°C/24°C

# 18. Exploded View and Replacement Parts List

## 18.1 Indoor Unit

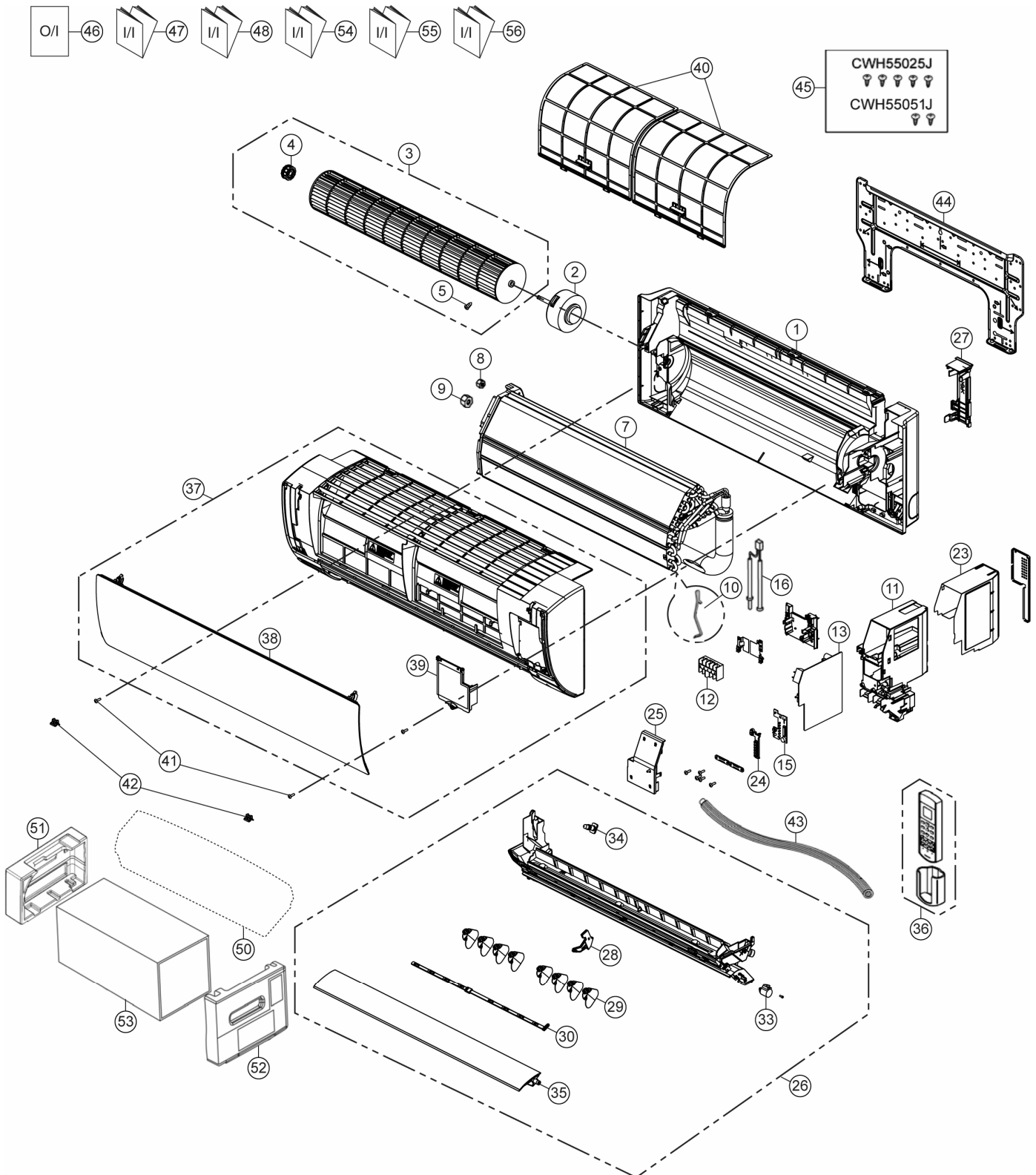

**Note**  
 The above exploded view is for the purpose of parts disassembly and replacement.  
 The non-numbered parts are not kept as standard service parts.

REF. NO.	PART NAME & DESCRIPTION	QTY.	CS-CE9NKE	CS-CE12NKE	REMARK
1	CHASSIS COMPLETE	1	CWD50C1653	←	
2	FAN MOTOR	1	ARW6101CB	←	O
3	CROSS-FLOW FAN COMPLETE	1	CWH02C1076	←	
4	BEARING ASSY	1	CWH64K007	←	
5	SCREW - CROSS-FLOW FAN	1	CWH551146	←	
7	EVAPORATOR	1	CWB30C3097	CWB30C4153	
8	FLARE NUT (LIQUID)	1	CWT251030	←	
9	FLARE NUT (GAS)	1	CWT251031	←	
10	CLIP FOR SENSOR	1	CWH32143	←	
11	CONTROL BOARD CASING	1	CWH102449	←	
12	TERMINAL BOARD COMPLETE	1	CWA28C2364	←	
13	ELECTRONIC CONTROLLER - MAIN	1	CWA73C6844	CWA73C6845	O
15	ELECTRONIC CONTROLLER - INDICATOR	1	CWA746963	←	O
16	SENSOR COMPLETE	1	CWA50C2401	←	
23	CONTROL BOARD TOP COVER	1	CWH131467	←	
24	INDICATOR HOLDER	1	CWD933406	←	
25	CONTROL BOARD FRONT COVER CO.	1	CWH13C1247	←	
26	DISCHARGE GRILLE COMPLETE	1	CWE20C3236	←	
27	BACK COVER CHASSIS	1	CWD933233	←	
28	FULCRUM	1	CWH621131	←	
29	VERTICAL VANE	8	CWE241374	←	
30	CONNECTING BAR	2	CWE261251	←	
33	AIR SWING MOTOR	1	CWA981264	←	O
34	CAP - DRAIN TRAY	1	CWH521259	CWH521096	
35	HORIZONTAL VANE COMPLETE	1	CWE24C1385	←	
36	REMOTE CONTROL COMPLETE	1	CWA75C4169	←	O
37	FRONT GRILLE COMPLETE	1	CWE11C5439	←	O
38	INTAKE GRILLE COMPLETE	1	CWE22C1723	←	O
39	GRILLE DOOR COMPLETE	1	CWE14C1090	←	
40	AIR FILTER	2	CWD001279	←	
41	SCREW - FRONT GRILLE	2	XTT4+16CFJ	←	
42	CAP - FRONT GRILLE	2	CWH521227	←	
43	DRAIN HOSE	1	CWH851173	←	
44	INSTALLATION PLATE	1	CWH361134	←	
45	BAG COMPLETE - INSTALLATION SCREW	1	CWH82C1705	←	
46	OPERATING INSTRUCTION	1	CWF568751	←	
47	INSTALLATION INSTRUCTION	1	CWF615526	←	
48	INSTALLATION INSTRUCTION	1	CWF615527	←	
50	BAG	1	CWG861497	←	
51	SHOCK ABSORBER ( L )	1	CWG713386	←	
52	SHOCK ABSORBER ( R )	1	CWG713387	←	
53	C.C.CASE	1	CWG567354	←	
54	INSTALLATION INSTRUCTION	1	CWF615528	←	



55	INSTALLATION INSTRUCTION	1	CWF615529	←	
56	INSTALLATION INSTRUCTION	1	CWF615530	←	

(Note)

- All parts are supplied from PAPAMY, Malaysia (Vendor Code: 00029488).
- "O" marked parts are recommended to be kept in stock.

## 18.2 Outdoor Unit

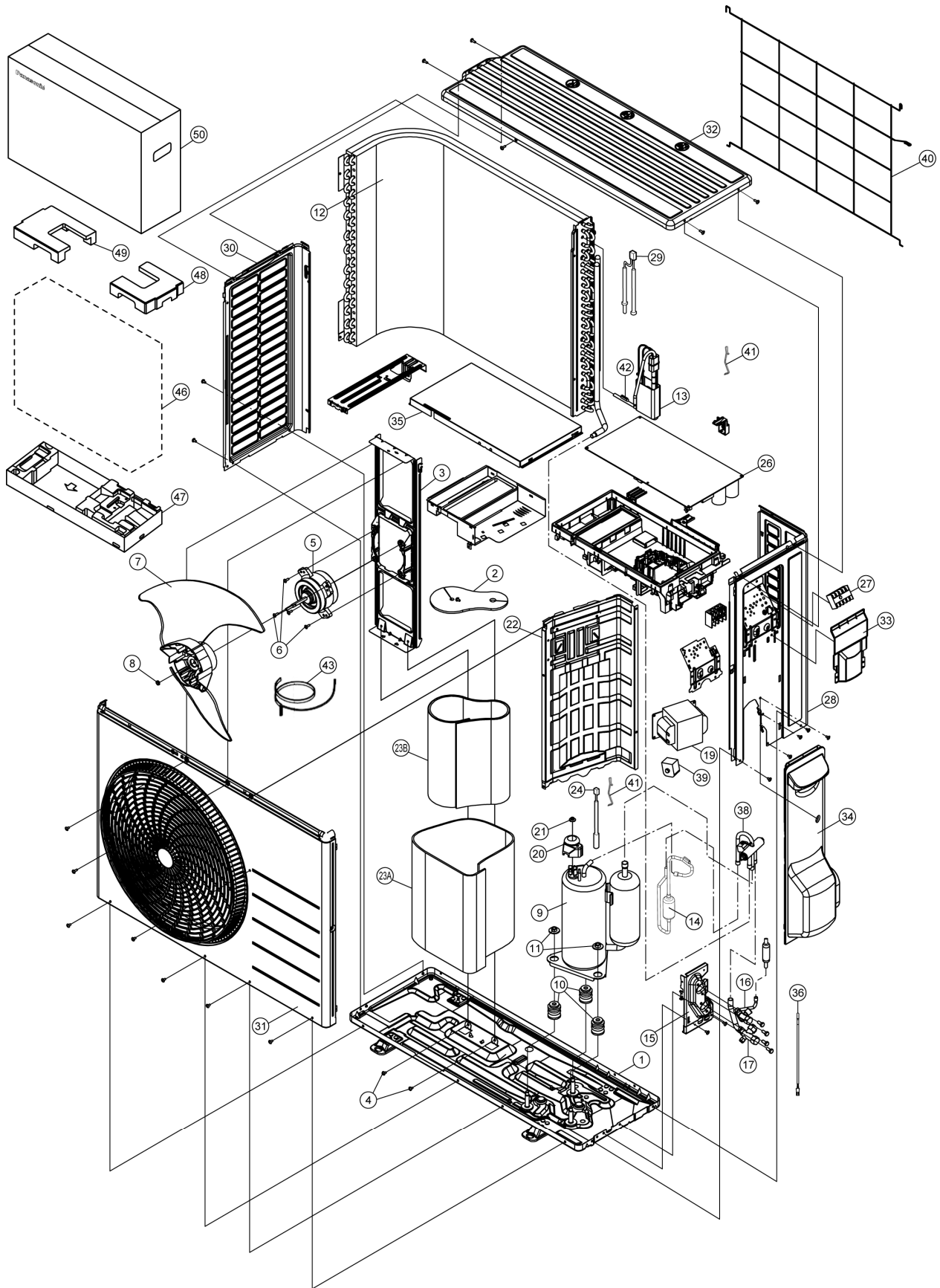

**Note**  
The above exploded view is for the purpose of parts disassembly and replacement.  
The non-numbered parts are not kept as standard service parts.

REF. NO.	PART NAME & DESCRIPTION	QTY.	CU-CE9NKE	CU-CE12NKE	REMARK
1	CHASSIS ASSY	1	CWD52K1310	←	
2	SOUND PROOF MATERIAL	1	CWG302742	←	
3	FAN MOTOR BRACKET	1	CWD541167	←	
4	SCREW - FAN MOTOR BRACKET	2	CWH551217	←	
5	FAN MOTOR	1	CWA951853	CWA951854	O
6	SCREW - FAN MOTOR MOUNT	4	CWH55252J	←	
7	PROPELLER FAN ASSY	1	CWH03K1066	←	
8	NUT - PROPELLER FAN	1	CWH56053J	←	
9	COMPRESSOR	1	5RD132XBE21	←	O
10	ANTI - VIBRATION BUSHING	3	CWH50077	←	
11	NUT - COMPRESSOR MOUNT	3	CWH56000J	←	
12	CONDENSER	1	CWB32C3560	←	
13	CAPILLARY TUBE ASSY	1	CWT01C6150	CWT01C6152	
14	DISCHARGE MUFFLER	1	CWB121010	←	
15	HOLDER COUPLING	1	CWH351233	←	
16	2-WAYS VALVE (LIQUID)	1	CWB021400	←	O
17	3-WAY VALVE (GAS)	1	CWB011374	←	O
19	REACTOR	1	G0C193J00004	←	
20	TERMINAL COVER	1	CWH171039A	←	
21	NUT - TERMINAL COVER	1	CWH7080300J	←	
22	SOUND PROOF BOARD	1	CWH151274	←	
23A	SOUND PROOF MATERIAL	1	CWG302741	←	
23B	SOUND PROOF MATERIAL	1	CWG302745	←	
24	SENSOR CO. - COMP TEMP	1	CWA50C2894	←	O
26	ELECTRONIC CONTROLLER - MAIN	1	CWA73C6853R	CWA73C6854R	O
27	TERMINAL BOARD ASSY	1	CWA28K1036J	←	O
28	CABINET SIDE PLATE CO.	1	CWE04C1296	←	
29	SENSOR CO.- AIR AND PIPE TEMP	1	CWA50C2893	←	O
30	CABINET SIDE PLATE (L)	1	CWE041580A	←	
31	CABINET FRONT PLATE CO.	1	CWE06C1441	←	
32	CABINET TOP PLATE	1	CWE031148A	←	
33	PLATE-C.B.COVER	1	CWH131470A	←	
34	CONTROL BOARD COVER CO.	1	CWH13C1253	←	
35	CONTROL BOARD COVER	1	CWH131473	←	
36	CRANKCASE HEATER (BASE PAN)	1	CWA341072	←	
38	4-WAYS VALVE	1	CWB001037J	←	
39	V-COIL COMPLETE	1	CWA43C2431	←	
40	WIRE NET	1	CWD041166A	←	
41	HOLDER SENSOR	2	CWH32143	←	
42	HOLDER SENSOR	1	CWH32075	←	
43	CRANKCASE HEATER	1	CWA341044	←	
46	BAG	1	CWG861078	←	
47	BASE BOARD - COMPLETE	1	CWG62C1162	←	
48	SHOCK ABSORBER (R)	1	CWG713415	←	
49	SHOCK ABSORBER (L)	1	CWG713416	←	
50	C.C. CASE	1	CWG566848	←	

(Note)

- All parts are supplied from PAPAMY, Malaysia (Vendor Code: 00029488).
- "O" marked parts are recommended to be kept in stock.