

RAM-130QH5

SERVICE MANUAL

TECHNICAL INFORMATION

REFER TO THE FOUNDATION MANUAL

FOR SERVICE PERSONNEL ONLY

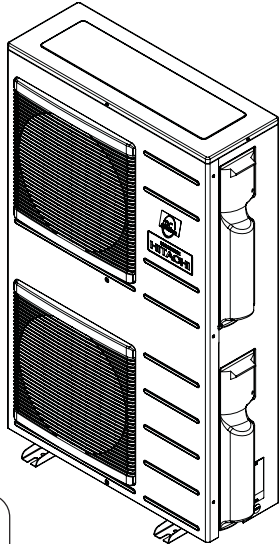

RAM-130QH5

CONTENTS

SPECIFICATIONS	5
INSTALLATION	13
CONSTRUCTION AND DIMENSIONAL DIAGRAM	17
MAIN PARTS COMPONENT	18
CAPACITY DIAGRAM	20
WIRING DIAGRAM	25
CIRCUIT DIAGRAM	27
BLOCK DIAGRAM	33
BASIC MODE	35
REFRIGERATING CYCLE DIAGRAM	55
DESCRIPTION OF MAIN CIRCUIT OPERATION	57
TROUBLE SHOOTING	88
DISASSEMBLY AND REASSEMBLY	95
PARTS LIST AND DIAGRAM	98

NOTE:

This manual describes only points that differ from RAF-25, 35, 50NH5, RAD-25, 35NH5, RAD-25, 35NH5 and RAM-80QH5 (TC No. 0771EF), RAI-25, 35NH5 (PM No. 0271E), RAI-50NH5 and RAC-50NH5 (PM No. 0274E), RAK-18, 25, 35NH5 (PM No. 0269E), RAK-50NH5 and RAC-50NH5 (PM No. 0302E) for items not described in this manual.

SPECIFICATIONS

TYPE	DC INVERTER DUAL SYSTEM MULTI	
	OUTDOOR UNIT	
MODEL	RAM-130QH5	
POWER SOURCE	1 ϕ , 220 - 240V, 50Hz	
TOTAL INPUT (W)	REFER TO THE SPECIFICATIONS PAGE	
TOTAL AMPERES (A)		
COOLING CAPACITY (kW)		
HEATING CAPACITY (B.T.U.)		
DIMENSIONS (mm)	W	855
	H	1450
	D	308
NET WEIGHT (kg)	113	

※ After installation

SPECIFICATIONS AND PARTS ARE SUBJECT TO CHANGE FOR IMPROVEMENT

ROOM AIR CONDITIONER

OUTDOOR UNIT

MARCH 2007 Refrigeration & Air-Conditioning Division

SAFETY DURING REPAIR WORK

1. In order to disassemble and repair the unit in question, be sure to disconnect the power cord plug from the power outlet before starting the work.

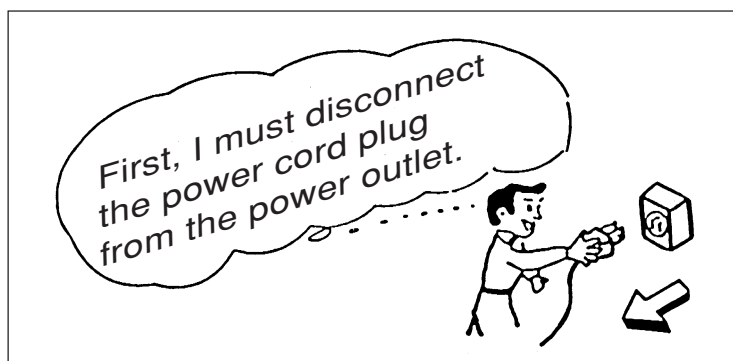

2. If it is necessary to replace any parts, they should be replaced with respective genuine parts for the unit, and the replacement must be effected in correct manner according to the instructions in the Service Manual of the unit.

If the contacts of electrical parts are defective, replace the electrical parts without trying to repair them.

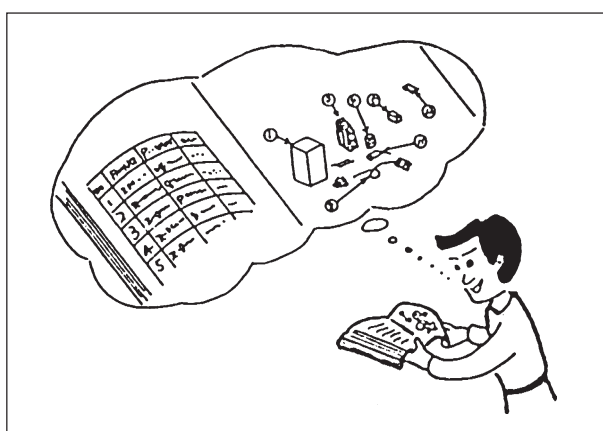

3. After completion of repairs, the initial state should be restored.
4. Lead wires should be connected and laid as in the initial state.
5. Modification of the unit by user himself should absolutely be prohibited.
6. Tools and measuring instruments for use in repairs or inspection should be accurately calibrated in advance.
7. In installing the unit having been repaired, be careful to prevent the occurrence of any accident such as electrical shock, leak of current, or bodily injury due to the drop of any part.
8. To check the insulation of the unit, measure the insulation resistance between the power cord plug and grounding terminal of the unit. The insulation resistance should be $1M\Omega$ or more as measured by a 500V DC megger.
9. The initial location of installation such as window, floor or the other should be checked for being and safe enough to support the repaired unit again. If it is found not so strong and safe, the unit should be installed at the initial location reinforced or at a new location.
10. Any inflammable thing should never be placed about the location of installation.
11. Check the grounding to see whether it is proper or not, and if it is found improper, connect the grounding terminal to the earth.



WORKING STANDARDS FOR PREVENTING BREAKAGE OF SEMICONDUCTORS

1. Scope

The standards provide for items to be generally observed in carrying and handling semiconductors in relative manufacturers during maintenance and handling thereof. (They apply the same to handling of abnormal goods such as rejected goods being returned).

2. Object parts

- (1) Micro computer
- (2) Integrated circuits (IC)
- (3) Field-effect transistors (FET)
- (4) P.C. boards or the like on which the parts mentioned in (1) and (2) of this paragraph are equipped.

3. Items to be observed in handling

- (1) Use a conductive container for carrying and storing of parts. (Even rejected goods should be handled in the same way).

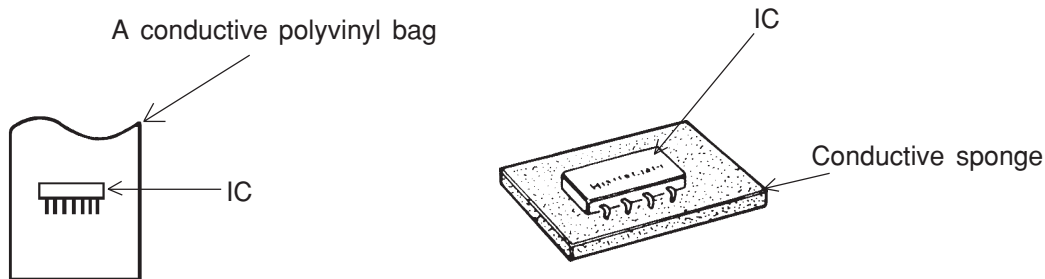

Fig. 1. Conductive Container

- (2) When any part is handled uncovered (in counting, packing and the like), the handling person must always use himself as a body earth. (Make yourself a body earth by passing one M ohm earth resistance through a ring or bracelet).
- (3) Be careful not to touch the parts with your clothing when you hold a part even if a body earth is being taken.
- (4) Be sure to place a part on a metal plate with grounding.
- (5) Be careful not to fail to turn off power when you repair the printed circuit board. At the same time, try to repair the printed circuit board on a grounded metal plate.

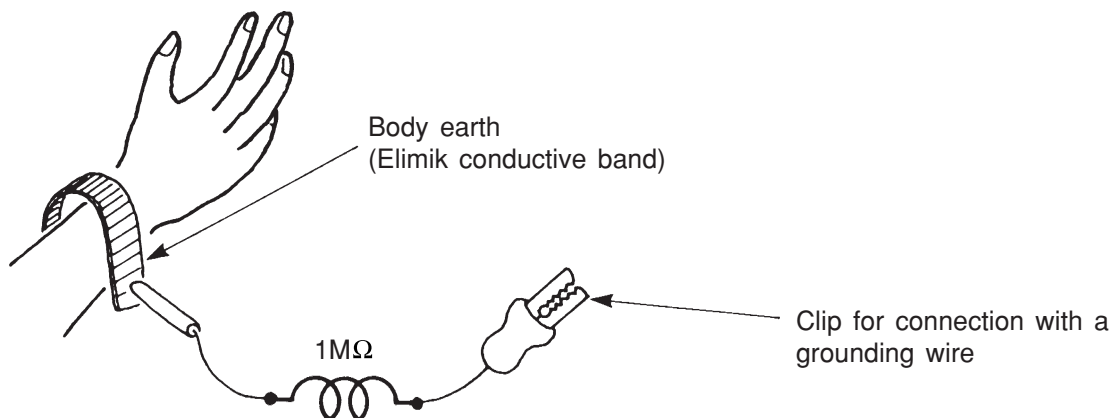

Fig. 2. Body Earth

(6) Use a three wire type soldering iron including a grounding wire.

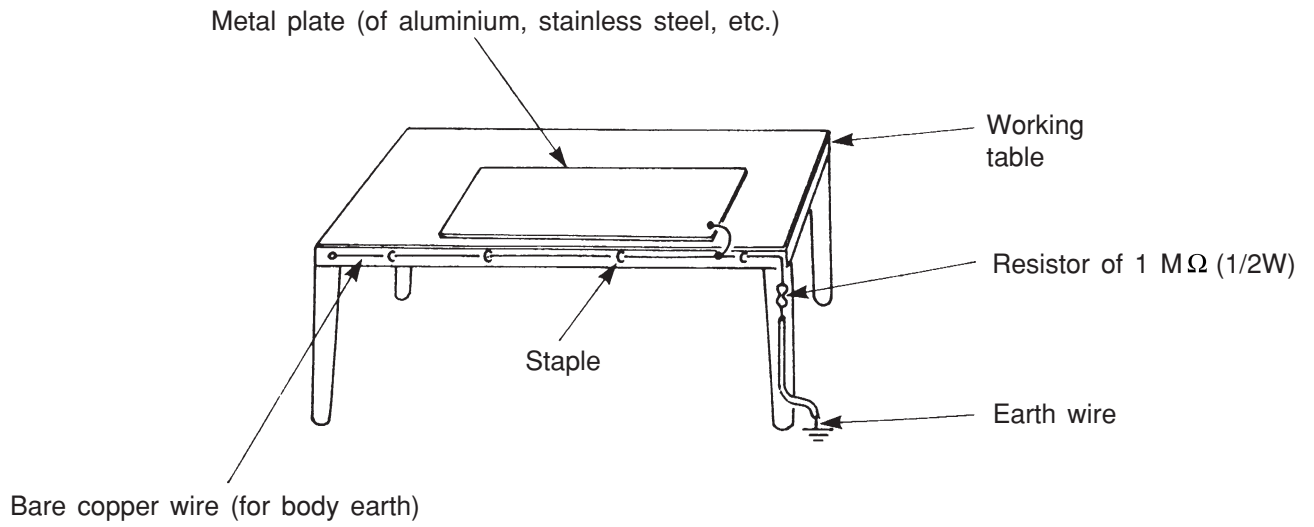

Fig. 3. Grounding of the working table

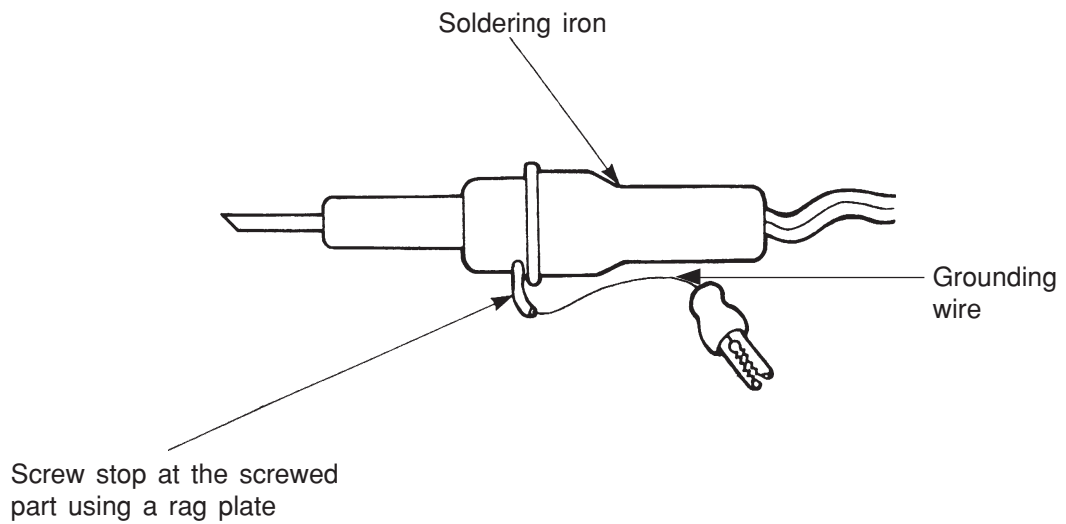

Fig. 4. Grounding a soldering iron

Use a high insulation mode (100V, 10MΩ or higher) when ordinary iron is to be used.

(7) In checking circuits for maintenance, inspection or some others, be careful not to have the test probes of the measuring instrument shortcircuit a load circuit or the like.

 **CAUTION**

1. In quiet operation or stopping the running, slight flowing noise of refrigerant in the refrigerating cycle is heard occasionally, but this noise is not abnormal for the operation.
2. When it thunders near by, it is recommend to stop the operation and to disconnect the power cord plug from the power outlet for safety.
3. The room air conditioner does not start automatically after recovery of the electric power failure for preventing fuse blowing. Re-press START/STOP button after 3 minutes from when unit stopped.
4. If the room air conditioner is stopped by adjusting thermostat, or missoperation, and re-start in a moment, there is occasion that the cooling and heating operation does not start for 3 minutes, it is not abnormal and this is the result of the operation of IC delay circuit. This IC delay circuit ensures that there is no danger of blowing fuse or damaging parts even if operation is restarted accidentally.
5. This room air conditioner should not be used at the cooling operation when the outside temperature is below -10°C (14°F).
6. This room air conditioner (the reverse cycle) should not be used when the outside temperature is below -15°C (5°F). If the reverse cycle is used under this condition, the outside heat exchanger is frosted and efficiency falls.
7. When the outside heat exchanger is frosted, the frost is melted by operating the hot gas system, it is not trouble that at this time fan stops and the vapour may rise from the outside heat exchanger.
8. This outdoor room airconditioner contain two refregeremt cycle with two compessor separately. Unit 1, 2, 3 and unit 4, 5, 6 are with different cycle
9. Unit 3 and unit 6 has to be connected to ensure no frost or ice remain at bottom of condensor.
10. Unit 2, 3 and unit 5, 6 has to be connected at least to ensure the compessor liability last longer.

SPECIFICATIONS

MODEL	RAM-130QH5		
FAN MOTOR	40 W		
FAN MOTOR CAPACITOR	NO		
FAN MOTOR PROTECTOR	NO		
COMPRESSOR	JU1013D2		
COMPRESSOR MOTOR CAPACITOR	NO		
OVERLOAD PROTECTOR	YES		
OVERHEAT PROTECTOR	YES		
FUSE (for MICROPROCESSOR)	5.0A		
POWER RELAY	G4A		
POWER SWITCH	NO		
TEMPORARY SWITCH	NO		
SERVICE SWITCH	YES		
TRANSFORMER	NO		
VARISTOR	450NR		
NOISE SUPPRESSOR	YES		
THERMOSTAT	YES(IC)		
REMOTE CONTROL SWITCH (LIQUID CRYSTAL)	NO		
REFRIGERANT CHARGING VOLUME (Refrigerant 410A)	UNIT	1650g + 1650g	
		WITHOUT REFRIGERANT BECAUSE COUPLING IS FLARE TYPE.	
	PIPES	INDOOR 1, 2, 3	INDOOR 4, 5, 6
		MAX. 45m	MAX. 45m

※ This outdoor unit has two separated refrigerant cycle with two compressors which indoor units 1, 2, 3 are for upper refrigerant cycle and indoor units 4, 5, 6 are for lower refrigerant cycle. In case the total pipe length of each cycle is more than 35m, add refrigerant R410A at 20 gram per every meter exceeded.

SPECIFICATIONS FOR INDOOR UNITS COMBINATION

TYPE		DC INVERTER SIX SYSTEM MULTI COOLING AND HEATING
MODEL	OUTDOOR UNIT	RAM-130QH5
PHASE/VOLTAGE/FREQUENCY		1ø, 220 - 240V, 50Hz
CIRCUIT AMPERES TO CONNECT (A)		30
COOLING (SIX UNITS)	CAPACITY (kW) (B.T.U./h)	12.60 (1.50 - 13.20)
		43,010 (5,120 - 45,060)
	TOTAL INPUT (W)	4,190 (200 - 4,400)
	EER (B.T.U./hW)	10.26
	TOTAL AMPERES (A)	19.2 - 17.6
POWER FACTOR (%)		99
HEATING (SIX UNITS)	CAPACITY (kW) (B.T.U./h)	14.40 (1.50 - 14.40)
		49,140 (5,120 - 49,140)
	TOTAL INPUT (W)	3,800 (200 - 4,220)
	EER (B.T.U./hW)	12.93
	TOTAL AMPERES (A)	17.40 - 16.00
POWER FACTOR (%)		99
MAXIMUM LENGTH OF PIPING		MAX. 45m (EACH CYCLE)
STANDARD		CE (EMC&LVD)

MODEL	RAM-130QH5	
PACKING (mm)	W	1,070
	H	1,590
	D	450
	cu.ft.	27.04
GROSS WEIGHT (kg)		130
FLARENUTSIZE (SMALL/LARGE)		6.35D/9.52DX6

OPERATION SCOPE

	INDOOR SUCTION TEMPERATURE (°C)	OUTDOOR SUCTION TEMPERATURE (°C)	INDOOR SUCTION HUMIDITY (%)
COOLING OPERATION SCOPE	16 - 32	22 - 41	BELOW 80
DEHUMIDIFYING OPERATION	16 - 32	22 - 42	BELOW 80
HEATING OPERATION SCOPE	BELOW 27	-15 - 23	—

SIX ROOM SYSTEM MULTI R.A.C. RAM-130QH5 COOL / HEAT CAPACITY SPEC. FOR INDOOR UNITS COMBINATIONS TO BE ABLE TO OPERATE SIMULTANEOUSLY

Whichever indoor units are installed, cooling and heating capacity depends on how many and which indoor units are operating at that time.

**6 ROOM MULTI-SPLIT INVERTER TYPE RAM-130QH5
POSSIBLE COMBINATION TO OPERATE (SAME TIME OPERATION)**

ONE UNIT	TWO UNITS	THREE UNITS	FOUR UNITS	POSSIBLE COMBINATIONS TO OPERATE	COOLING				HEATING						
					CAPACITY REATING (KW) (RANGE)	OUTDOOR UNIT		COP	CAPACITY REATING (KW) (RANGE)	OUTDOOR UNIT		COP			
						POWER CONSUMPTION (W)	AMPERE (A) @230V			POWER CONSUMPTION (W)	AMPERE (A) @230V				
				1.8 (1.00 - 2.50)	1.80 (200 - 750)	2.5	3.21	2.50 (1.10 - 3.20)	2.50 (200 - 1050)	3.3	3.33				
				2.5 (1.50 - 2.80)	2.50 (200 - 980)	3.4	3.21	3.90 (1.50 - 4.70)	3.90 (200 - 1920)	5.0	3.41				
				3.5 (1.00 - 3.90)	3.50 (200 - 1280)	5.1	3.02	4.80 (1.10 - 5.80)	4.80 (200 - 1870)	6.8	3.10				
				5.0 (1.00 - 5.60)	5.00 (200 - 1960)	7.2	2.81	6.50 (1.10 - 7.20)	6.50 (200 - 2660)	10.5	2.71				
				1.8 + 1.8 (1.50 - 4.00)	3.60 (200 - 1300)	5.2	3.03	2.50 + 2.50 (1.40 - 5.20)	2.50 + 2.50 (200 - 1550)	6.4	3.42				
				1.8 + 2.5 (1.50 - 4.60)	4.20 (200 - 1450)	5.8	3.21	2.40 + 3.80 (1.50 - 7.20)	2.40 + 3.80 (200 - 1920)	8.0	3.41				
				1.8 + 3.5 (1.50 - 5.60)	5.00 (200 - 1820)	7.2	3.03	2.30 + 4.50 (1.50 - 7.20)	2.30 + 4.50 (200 - 2100)	8.8	3.41				
				1.8 + 5.0 (1.50 - 5.90)	5.40 (200 - 1980)	7.9	3.01	2.00 + 5.00 (1.50 - 7.20)	2.00 + 5.00 (200 - 2100)	9.0	3.41				
				2.5 + 2.5 (1.50 - 5.60)	5.00 (200 - 1820)	7.2	3.03	3.40 + 3.40 (1.50 - 7.20)	3.40 + 3.40 (200 - 2100)	8.8	3.37				
				2.5 + 3.5 (1.50 - 5.70)	5.20 (200 - 1900)	7.6	3.01	3.15 + 3.85 (1.50 - 7.20)	3.15 + 3.85 (200 - 2100)	9.1	3.38				
				2.5 + 5.0 (1.50 - 5.90)	5.40 (200 - 1980)	7.9	3.01	3.60 + 3.60 (1.50 - 7.20)	3.60 + 3.60 (200 - 2110)	9.3	3.41				
				3.5 + 5.0 (1.50 - 5.90)	5.40 (200 - 1980)	7.9	3.01	3.05 + 4.15 (1.50 - 7.20)	3.05 + 4.15 (200 - 2110)	9.3	3.41				
				2.20 + 3.20 (1.50 - 5.90)	5.40 (200 - 2200)	8.8	2.71	3.05 + 4.15 (1.50 - 7.20)	3.05 + 4.15 (200 - 2110)	9.3	3.41				
				1.8 + 1.8 + 1.8 (1.50 - 6.30)	5.40 (200 - 2200)	7.8	3.03	2.33 + 2.33 + 2.33 (1.50 - 7.20)	2.33 + 2.33 + 2.33 (200 - 2110)	8.2	3.78				
				1.8 + 1.8 + 2.5 (1.50 - 6.40)	6.10 (200 - 2200)	8.9	3.02	2.00 + 2.00 + 3.20 (1.50 + 7.20)	2.00 + 2.00 + 3.20 (200 - 2110)	8.4	3.79				
				1.8 + 1.8 + 3.5 (1.50 - 6.60)	6.30 (200 - 2200)	9.2	3.01	1.85 + 1.85 + 3.50 (1.50 + 7.20)	1.85 + 1.85 + 3.50 (200 - 2110)	8.4	3.79				
				1.8 + 1.8 + 5.0 (1.50 - 6.60)	6.30 (200 - 2200)	9.2	3.01	1.80 + 1.80 + 4.00 (1.50 + 7.20)	1.80 + 1.80 + 4.00 (200 - 2110)	8.4	3.79				
				1.8 + 2.5 + 2.8 (1.50 - 6.60)	6.30 (200 - 2200)	9.2	3.01	2.40 + 2.40 + 2.70 (1.50 + 7.20)	2.40 + 2.40 + 2.70 (200 - 2110)	8.4	3.79				
				1.8 + 2.5 + 3.5 (1.50 - 6.60)	6.30 (200 - 2200)	9.2	3.01	1.60 + 2.50 + 3.10 (1.50 + 7.20)	1.60 + 2.50 + 3.10 (200 - 2110)	8.4	3.79				
				1.8 + 3.5 + 3.5 (1.50 - 6.60)	6.30 (200 - 2200)	9.2	3.01	1.40 + 2.90 + 2.90 (1.50 + 7.20)	1.40 + 2.90 + 2.90 (200 - 2110)	8.4	3.79				
				2.5 + 2.5 + 2.5 (1.50 - 6.60)	6.30 (200 - 2200)	9.2	3.01	2.40 + 2.40 + 2.40 (1.50 + 7.20)	2.40 + 2.40 + 2.40 (200 - 2110)	8.4	3.79				
				2.5 + 2.5 + 3.5 (1.50 - 6.60)	6.30 (200 - 2200)	9.2	3.01	2.23 + 2.23 + 2.74 (1.50 + 7.20)	2.23 + 2.23 + 2.74 (200 - 2110)	8.4	3.79				
				1.8, 1.8, 1.8, 1.8 (1.50 - 8.00)	7.20 (200 - 2600)	10.5	3.03	(2.50 + 2.50) + (2.50 + 2.50) (1.50 - 10.40)	2.90 (200 - 3100)	12.8	3.42				
				1.8, 1.8, 1.8, 2.5 (1.50 - 8.60)	7.80 (200 - 2750)	11.0	3.12	(2.50 + 2.50) + (2.40 + 3.80) (1.50 - 11.50)	3.20 (200 - 3470)	14.4	3.41				
				1.8, 1.8, 2.5, 2.5 (1.50 - 8.60)	8.40 (200 - 2900)	11.5	3.21	(2.40 + 3.80) + (2.40 + 3.80) (1.50 - 13.50)	3.60 (200 - 3840)	16.0	3.41				
				1.8, 1.8, 1.8, 3.5 (1.50 - 9.60)	8.60 (200 - 3120)	12.5	3.03	(2.50 + 2.50) + (2.30 + 4.50) (1.50 - 12.40)	3.45 (200 - 3650)	15.2	3.42				
				1.8, 1.8, 2.5, 3.5 (1.50 - 10.20)	9.20 (200 - 3270)	13.0	3.11	(2.40 + 3.80) + (2.30 + 4.50) (1.50 - 13.50)	3.81 (200 - 4020)	16.8	3.41				
				1.8, 1.8, 1.8, 5.0 (1.50 - 9.90)	9.60 (200 - 3280)	13.1	3.02	(2.50 + 2.50) + (2.00 + 5.00) (1.50 - 12.40)	3.50 (200 - 3650)	15.4	3.42				
				1.8, 1.8, 2.5, 5.0 (1.50 - 10.50)	9.60 (200 - 3430)	13.6	3.09	(2.40 + 3.80) + (2.00 + 5.00) (1.50 - 13.50)	3.70 (200 - 4020)	17.0	3.41				
				1.8, 1.8, 3.5, 3.5 (1.50 - 11.20)	10.00 (200 - 3640)	14.5	3.03	(2.30 + 4.50) + (2.30 + 4.50) (1.50 - 14.40)	3.90 (200 - 4200)	17.5	3.41				
				1.8, 1.8, 3.5, 5.0 (1.50 - 11.50)	10.40 (200 - 3800)	15.1	3.02	(2.30 + 4.50) + (2.00 + 5.00) (1.50 - 14.40)	4.05 (200 - 4200)	17.8	3.41				
				1.8, 1.8, 5.0, 5.0 (1.50 - 11.80)	10.80 (200 - 3960)	15.8	3.01	(2.00 + 5.00) + (2.00 + 5.00) (1.50 - 14.40)	4.10 (200 - 4200)	18.0	3.41				
				1.8, 2.5, 2.5, 2.5 (1.50 - 10.20)	9.20 (200 - 3270)	13.0	3.11	(2.40 + 3.80) + (3.40 + 3.40) (1.50 - 13.50)	4.05 (200 - 4020)	16.8	3.39				
				1.8, 2.5, 2.5, 5.0 (1.50 - 11.50)	10.40 (200 - 3800)	15.1	3.02	(2.00 + 5.00) + (3.40 + 3.40) (1.50 - 14.40)	4.65 (200 - 4200)	17.9	3.39				
				1.8, 2.5, 2.5, 3.5 (1.50 - 11.50)	10.00 (200 - 3640)	14.5	3.03	(2.30 + 4.50) + (3.40 + 3.40) (1.50 - 14.40)	4.10 (200 - 4200)	17.6	3.39				
				1.8, 2.5, 3.5, 3.5 (1.50 - 11.30)	10.20 (200 - 3720)	14.8	3.02	(2.30 + 4.50) + (3.15 + 3.85) (1.50 - 14.40)	4.65 (200 - 4200)	17.9	3.39				
				1.8, 2.5, 3.5, 5.0 (1.50 - 11.60)	10.60 (200 - 3880)	15.5	3.01	(2.00 + 5.00) + (3.15 + 3.85) (1.50 - 14.40)	4.20 (200 - 4200)	18.1	3.40				
				1.8, 2.5, 5.0, 5.0 (1.50 - 11.80)	10.80 (200 - 3960)	15.8	3.01	(2.00 + 5.00) + (2.70 + 4.50) (1.50 - 14.40)	4.16 (200 - 4210)	18.3	3.41				
				1.8, 3.5, 3.5, 3.5 (1.50 - 11.50)	10.40 (200 - 3800)	15.1	3.02	(2.30 + 4.50) + (3.60 + 3.60) (1.50 - 14.40)	4.05 (200 - 4210)	18.0	3.41				
				1.8, 3.5, 3.5, 5.0 (1.50 - 11.80)	10.80 (200 - 3960)	15.8	3.01	(2.00 + 5.00) + (3.60 + 3.60) (1.50 - 14.40)	4.16 (200 - 4210)	18.3	3.41				
				1.8, 3.5, 5.0, 5.0 (1.50 - 11.80)	10.80 (200 - 4180)	16.6	2.85	(2.00 + 5.00) + (3.05 + 4.15) (1.50 - 14.40)	4.16 (200 - 4210)	18.3	3.41				
				2.5, 2.5, 2.5, 2.5 (1.50 - 11.20)	10.00 (200 - 3640)	14.5	3.03	(3.40 + 3.40) + (3.40 + 3.40) (1.50 - 14.40)	4.03 (200 - 4200)	17.7	3.37				
				2.5, 2.5, 2.5, 3.5 (1.50 - 11.30)	10.20 (200 - 3720)	14.8	3.02	(3.40 + 3.40) + (3.15 + 3.85) (1.50 - 14.40)	4.05 (200 - 4200)	17.9	3.38				
				2.5, 2.5, 2.5, 5.0 (1.50 - 11.50)	10.40 (200 - 3800)	15.1	3.02	(3.40 + 3.40) + (2.70 + 4.50) (1.50 - 14.40)	4.25 (200 - 4210)	18.1	3.39				
				2.5, 2.5, 3.5, 3.5 (1.50 - 11.40)	10.40 (200 - 3800)	15.2	3.01	(3.15 + 3.85) + (3.15 + 3.85) (1.50 - 14.40)	4.14 (200 - 4200)	18.2	3.38				
				2.5, 2.5, 3.5, 5.0 (1.50 - 11.60)	10.60 (200 - 3880)	15.5	3.01	(2.70 + 4.50) + (3.15 + 3.85) (1.50 - 14.40)	4.18 (200 - 4210)	18.4	3.40				
				2.5, 2.5, 5.0, 5.0 (1.50 - 11.80)	10.80 (200 - 3960)	15.8	3.01	(2.70 + 4.50) + (2.70 + 4.50) (1.50 - 14.40)	4.20 (200 - 4220)	18.5	3.41				
				2.5, 3.5, 3.5, 3.5 (1.50 - 11.60)	10.60 (200 - 3880)	15.5	3.01	(3.15 + 3.85) + (3.60 + 3.60) (1.50 - 14.40)	4.18 (200 - 4210)	18.4	3.40				
				2.5, 3.5, 3.5, 5.0 (1.50 - 11.80)	10.80 (200 - 3960)	15.8	3.01	(2.70 + 4.50) + (3.60 + 3.60) (1.50 - 14.40)	4.20 (200 - 4220)	18.5	3.41				
				3.5, 3.5, 3.5, 3.5 (1.50 - 11.80)	10.80 (200 - 3960)	15.8	3.01	(3.60 + 3.60) + (3.60 + 3.60) (1.50 - 14.40)	4.20 (200 - 4220)	18.5	3.41				
				3.5, 3.5, 3.5, 5.0 (1.50 - 11.80)	10.80 (200 - 4180)	16.6	2.85	(3.60 + 3.60) + (3.05 + 4.15) (1.50 - 14.40)	4.20 (200 - 4220)	18.5	3.41				
				3.5, 3.5, 5.0, 5.0 (1.50 - 11.80)	10.80 (200 - 4400)	17.5	2.71	(3.05 + 4.15) + (3.05 + 4.15) (1.50 - 14.40)	4.20 (200 - 4220)	18.5	3.41				

				1.8, 1.8, 1.8, 1.8 (1.50 - 10.00)	9.00 (200 - 3500)	13.0	3.03	(2.50 + 2.50) + (2.33 + 2.33 + 2.33) (1.50 - 12.40)	3.10 (200 - 3660)	14.5	3.63				
				1.8, 1.8, 1.8, 2.5 (1.50 - 10.40)	9.70 (200 - 3600)	14.1	3.02	(2.50 + 2.50) + (2.00 + 2.00 + 3.20) (1.50 - 12.40)	3.20 (200 - 3660)	14.8	3.63				
				1.8, 1.8, 1.8, 3.5 (1.50 - 11.60)	10.40 (200 - 4020)	15.1	3.03	(2.30 + 4.50) + (2.33 + 2.33 + 2.33) (1.50 - 14.40)	3.45 (200 - 4210)	16.9	3.59				
				1.8, 1.8, 1.8, 5.0 (1.50 - 11.90)	10.80 (200 - 4180)	15.7	3.02	(2.00 + 5.00) + (2.33 + 2.33 + 2.33) (1.50 - 14.40)	3.90 (200 - 4030)	17.1	3.59				
				1.8, 1.8, 1.8, 2.5, 2.5 (1.50 - 11.90)	10.30 (200 - 3650)	14.6	3.09	(2.40 + 3.80) + (2.00 + 2.00 + 3.20) (1.50 - 13.50)	3.70 (200 - 3960)	16.3	3.60				

SIX ROOMS SYSTEM MULTI R.A.C. *RAM-130QH5* INDOOR UNITS COMBINATIONS TO BE ABLE TO INSTALL

Four or more indoor units can be installed with one outdoor unit.
And total nominal cooling capacity should not be more than 18.0kW

INDOOR UNIT MODEL	NOMINAL COOLING CAPACITY (kW)	CAPACITY (kW) at one unit operation		SUITABLE ROOM SIZE (m ²) at one unit operation	
		COOLING	HEATING	COOLING	HEATING
RAK-18NH5 RAK-18NH6	1.8	1.00 - 2.50	1.10 - 3.20	8 - 12	9 - 11
RAK-25NH5 RAK-25NH6	2.5	1.00 - 2.80	1.10 - 4.70	11 - 17	14 - 18
RAF-25NH5	2.5	1.00 - 2.80	1.10 - 4.70	11 - 17	14 - 18
RAD-25NH5 RAD-25NH7	2.5	1.00 - 2.80	1.10 - 4.70	11 - 17	14 - 18
RAI-25NH5	2.5	1.00 - 2.80	1.10 - 4.70	11 - 17	14 - 18
RAK-35NH5 RAK-35NH6	3.5	1.00 - 3.90	1.10 - 5.80	16 - 24	17 - 22
RAF-35NH5	3.5	1.00 - 3.90	1.10 - 5.80	16 - 24	17 - 22
RAD-35NH5 RAD-35NH7	3.5	1.00 - 3.90	1.10 - 5.80	16 - 24	17 - 22
RAI-35NH5	3.5	1.00 - 3.90	1.10 - 5.80	16 - 24	17 - 22
RAK-50NH5 RAK-50NH6	5.0	1.00 - 5.60	1.10 - 7.20	23 - 34	23 - 29
RAF-50NH5	5.0	1.00 - 5.60	1.10 - 7.20	23 - 34	23 - 29
RAI-50NH5	5.0	1.00 - 5.60	1.10 - 7.20	23 - 34	23 - 29
RAD-50NH7	5.0	1.00 - 5.60	1.10 - 7.50	23 - 34	23 - 29

Be sure to connect four or more indoor units to this outdoor unit. If not, condensed water may drop, resulting in trouble.

At least four indoor unit to be connected to the outdoor unit which means two indoor units for each cycle (upper and lower). Anyway indoor unit 3 and 6 must be connected.

SIX ROOM SYSTEM MULTI R.A.C. RAM-130QH5 CONNECTING POSITION TO BE ABLE TO INSTALL

6 ROOM MULTI-SPLIT INVERTER TYPE RAC: RAM-130QH5
POSSIBLE COMBINATION TO OPERATE (SAME TIME OPERATION)

POSSIBLE COMBINATIONS TO INSTALL	SUITABLE ROOM SIZE TO INSTALL (m ²)	CONNECTION POSITION ON OUTDOOR UNIT (VALVE DIAMETER) (mm)					
		NO. 1 6.35/9.52D	NO. 2 6.35/9.52D	NO. 3 6.35/9.52D	NO. 4 6.35/9.52D	NO. 5 6.35/9.52D	NO. 6 6.35/9.52D
(1.8 + 1.8) + (1.8 + 1.8)	(8-12) + (8-12) + (8-12) + (8-12)		1.8	1.8		1.8	1.8
(1.8 + 1.8) + (1.8 + 2.5)	(8-12) + (8-12) + (8-12) + (10-16)		1.8	1.8		1.8	2.5
(1.8 + 2.5) + (1.8 + 2.5)	(8-12) + (10-16) + (8-12) + (10-16)		1.8	2.5		1.8	2.5
(1.8 + 1.8) + (1.8 + 3.5)	(8-12) + (8-12) + (7-9) + (15-22)		1.8	1.8		1.8	3.5
(1.8 + 2.5) + (1.8 + 3.5)	(8-12) + (10-16) + (7-9) + (15-22)		1.8	2.5		1.8	3.5
(1.8 + 1.8) + (1.8 + 5.0)	(8-12) + (8-12) + (6-9) + (18-27)		1.8	1.8		1.8	5.0
(1.8 + 2.5) + (1.8 + 5.0)	(8-12) + (10-16) + (6-9) + (18-27)		1.8	2.5		1.8	5.0
(1.8 + 3.5) + (1.8 + 3.5)	(7-9) + (15-22) + (7-9) + (15-22)		1.8	3.5		1.8	3.5
(1.8 + 3.5) + (1.8 + 5.0)	(7-9) + (15-22) + (6-9) + (18-27)		1.8	3.5		1.8	5.0
(1.8 + 5.0) + (1.8 + 5.0)	(6-9) + (18-27) + (6-9) + (18-27)		1.8	5.0		1.8	5.0
(1.8 + 2.5) + (2.5 + 2.5)	(8-12) + (10-16) + (12-15) + (12-15)		1.8	2.5		2.5	2.5
(1.8 + 5.0) + (2.5 + 2.5)	(6-9) + (18-27) + (12-15) + (12-15)		1.8	5.0		2.5	2.5
(1.8 + 3.5) + (2.5 + 2.5)	(7-9) + (15-22) + (12-15) + (12-15)		1.8	3.5		2.5	2.5
(1.8 + 3.5) + (2.5 + 3.5)	(7-9) + (15-22) + (11-14) + (14-18)		1.8	3.5		2.5	3.5
(1.8 + 5.0) + (2.5 + 3.5)	(6-9) + (18-27) + (11-14) + (14-18)		1.8	5.0		2.5	3.5
(1.8 + 5.0) + (2.5 + 5.0)	(6-9) + (18-27) + (10-12) + (18-20)		1.8	5.0		2.5	5.0
(1.8 + 3.5) + (3.5 + 3.5)	(7-9) + (15-22) + (13-16) + (13-16)		1.8	3.5		3.5	3.5
(1.8 + 5.0) + (3.5 + 3.5)	(6-9) + (18-27) + (13-16) + (13-16)		1.8	5.0		3.5	3.5
(1.8 + 5.0) + (3.5 + 5.0)	(6-9) + (18-27) + (11-14) + (16-18)		1.8	5.0		3.5	5.0
(2.5 + 2.5) + (2.5 + 2.5)	(12-15) + (12-15) + (12-15) + (12-15)		2.5	2.5		2.5	2.5
(2.5 + 2.5) + (2.5 + 3.5)	(12-15) + (12-15) + (11-14) + (14-18)		2.5	2.5		2.5	3.5
(2.5 + 2.5) + (2.5 + 5.0)	(12-15) + (12-15) + (10-12) + (18-20)		2.5	2.5		2.5	5.0
(2.5 + 3.5) + (2.5 + 3.5)	(11-14) + (14-18) + (11-14) + (14-18)		2.5	3.5		2.5	3.5
(2.5 + 5.0) + (2.5 + 3.5)	(10-12) + (18-20) + (11-14) + (14-18)		2.5	5.0		2.5	3.5
(2.5 + 5.0) + (2.5 + 5.0)	(10-12) + (18-20) + (10-12) + (18-20)		2.5	5.0		2.5	5.0
(2.5 + 3.5) + (3.5 + 3.5)	(11-14) + (14-18) + (13-16) + (13-16)		2.5	3.5		3.5	3.5
(2.5 + 5.0) + (3.5 + 3.5)	(10-12) + (18-20) + (13-16) + (13-16)		2.5	5.0		3.5	3.5
(3.5 + 3.5) + (3.5 + 3.5)	(13-16) + (13-16) + (13-16) + (13-16)		3.5	3.5		3.5	3.5
(3.5 + 3.5) + (3.5 + 5.0)	(13-16) + (13-16) + (11-14) + (16-18)		3.5	3.5		3.5	5.0
(3.5 + 5.0) + (3.5 + 5.0)	(11-14) + (16-18) + (11-14) + (16-18)		3.5	5.0		3.5	5.0
(1.8 + 1.8) + (1.8 + 1.8 + 1.8)	(8-12) + (8-12) + (8-12) + (8-12) + (8-12)		1.8	1.8	1.8	1.8	1.8
(1.8 + 1.8) + (1.8 + 1.8 + 2.5)	(8-12) + (8-12) + (8-12) + (8-12) + (11-17)		1.8	1.8	1.8	1.8	2.5
(1.8 + 3.5) + (1.8 + 1.8 + 1.8)	(7-9) + (15-22) + (8-12) + (8-12) + (8-12)		1.8	3.5	1.8	1.8	1.8
(1.8 + 5.0) + (1.8 + 1.8 + 1.8)	(6-9) + (18-27) + (8-12) + (8-12) + (8-12)		1.8	5.0	1.8	1.8	1.8
(1.8 + 2.5) + (1.8 + 1.8 + 2.5)	(8-12) + (10-16) + (8-12) + (8-12) + (11-17)		1.8	2.5	1.8	1.8	2.5

(1.8 + 2.5) + (1.8 + 1.8 + 2.5)	(8-12) + (10-16) + (8-12) + (8-12) + (11-17)		1.8	2.5	1.8	1.8	2.5
(1.8 + 3.5) + (1.8 + 1.8 + 2.5)	(7-9) + (15-22) + (8-12) + (8-12) + (11-17)		1.8	3.5	1.8	1.8	2.5
(1.8 + 5.0) + (1.8 + 1.8 + 2.5)	(6-9) + (18-27) + (8-12) + (8-12) + (11-17)		1.8	5.0	1.8	1.8	2.5
(1.8 + 3.5) + (1.8 + 1.8 + 3.5)	(7-9) + (15-22) + (7-11) + (7-11) + (14-21)		1.8	3.5	1.8	1.8	3.5
(1.8 + 5.0) + (1.8 + 1.8 + 3.5)	(6-9) + (18-27) + (7-11) + (7-11) + (14-21)		1.8	5.0	1.8	1.8	3.5
(1.8 + 5.0) + (1.8 + 1.8 + 5.0)	(6-9) + (18-27) + (5-8) + (5-8) + (16-25)		1.8	5.0	1.8	1.8	5.0
(2.5 + 2.5) + (1.8 + 1.8 + 2.5)	(12-15) + (12-15) + (8-12) + (8-12) + (11-17)		2.5	2.5	1.8	1.8	2.5
(2.5 + 3.5) + (1.8 + 1.8 + 2.5)	(11-14) + (14-18) + (8-12) + (8-12) + (11-17)		2.5	3.5	1.8	1.8	2.5
(1.8 + 5.0) + (1.8 + 2.5 + 2.5)	(6-9) + (18-27) + (7-11) + (10-15) + (10-15)		1.8	5.0	1.8	2.5	2.5
(3.5 + 3.5) + (1.8 + 1.8 + 2.5)	(13-16) + (13-16) + (8-12) + (8-12) + (11-17)		3.5	3.5	1.8	1.8	2.5
(1.8 + 5.0) + (1.8 + 2.5 + 3.5)	(6-9) + (18-27) + (6-10) + (9-13) + (12-19)		1.8	5.0	1.8	2.5	3.5
(3.5 + 3.5) + (1.8 + 1.8 + 3.5)	(13-16) + (13-16) + (7-11) + (7-11) + (14-21)		3.5	3.5	1.8	1.8	3.5
(2.5 + 2.5) + (1.8 + 2.5 + 2.5)	(12-15) + (12-15) + (7-11) + (10-15) + (10-15)		2.5	2.5	1.8	2.5	2.5
(2.5 + 3.5) + (1.8 + 2.5 + 2.5)	(11-14) + (14-18) + (7-11) + (10-15) + (10-15)		2.5	3.5	1.8	2.5	2.5
(1.8 + 5.0) + (2.5 + 2.5 + 2.5)	(6-9) + (18-27) + (10-11) + (10-11) + (10-11)		1.8	5.0	2.5	2.5	2.5
(3.5 + 3.5) + (1.8 + 2.5 + 2.5)	(13-16) + (13-16) + (7-11) + (10-15) + (10-15)		3.5	3.5	1.8	2.5	2.5
(2.5 + 5.0) + (1.8 + 2.5 + 3.5)	(10-12) + (18-20) + (6-10) + (9-13) + (12-19)		2.5	5.0	1.8	2.5	3.5
(3.5 + 3.5) + (1.8 + 2.5 + 3.5)	(13-16) + (13-16) + (6-10) + (9-13) + (12-19)		3.5	3.5	1.8	2.5	3.5
(3.5 + 3.5) + (1.8 + 3.5 + 3.5)	(13-16) + (13-16) + (5-8) + (11-17) + (11-17)		3.5	3.5	1.8	3.5	3.5
(2.5 + 2.5) + (2.5 + 2.5 + 2.5)	(12-15) + (12-15) + (10-11) + (10-11) + (10-11)		2.5	2.5	2.5	2.5	2.5
(2.5 + 3.5) + (2.5 + 2.5 + 2.5)	(11-14) + (14-18) + (10-11) + (10-11) + (10-11)		2.5	3.5	2.5	2.5	2.5
(2.5 + 5.0) + (2.5 + 2.5 + 2.5)	(10-12) + (18-20) + (10-11) + (10-11) + (10-11)		2.5	5.0	2.5	2.5	2.5
(3.5 + 3.5) + (2.5 + 2.5 + 2.5)	(13-16) + (13-16) + (10-11) + (10-11) + (10-11)		3.5	3.5	2.5	2.5	2.5
(2.5 + 5.0) + (2.5 + 2.5 + 3.5)	(10-12) + (18-20) + (8-10) + (8-10) + (12-12)		2.5	5.0	2.5	2.5	3.5
(3.5 + 3.5) + (2.5 + 2.5 + 3.5)	(13-16) + (13-16) + (8-10) + (8-10) + (12-12)		3.5	3.5	2.5	2.5	3.5
(3.5 + 5.0) + (2.5 + 2.5 + 3.5)	(11-14) + (16-18) + (8-10) + (8-10) + (12-12)		3.5	5.0	2.5	2.5	3.5
(1.8 + 1.8 + 1.8) + (1.8 + 1.8 + 1.8)	(8-12) + (8-12) + (8-12) + (8-12) + (8-12)	1.8	1.8	1.8	1.8	1.8	1.8
(1.8 + 1.8 + 1.8) + (1.8 + 1.8 + 2.5)	(8-12) + (8-12) + (8-12) + (8-12) + (11-17)	1.8	1.8	1.8	1.8	1.8	2.5
(1.8 + 1.8 + 1.8) + (1.8 + 1.8 + 3.5)	(8-12) + (8-12) + (8-12) + (7-11) + (7-11) + (14-21)	1.8	1.8	1.8	1.8	1.8	3.5
(1.8 + 1.8 + 1.8) + (1.8 + 1.8 + 5.0)	(8-12) + (8-12) + (8-12) + (5-8) + (5-8) + (16-25)	1.8	1.8	1.8	1.8	1.8	5.0
(1.8 + 1.8 + 2.5) + (1.8 + 1.8 + 2.5)	(8-12) + (8-12) + (11-17) + (8-12) + (8-12) + (11-17)	1.8	1.8	2.5	1.8	1.8	2.5
(1.8 + 1.8 + 2.5) + (1.8 + 1.8 + 3.5)	(8-12) + (8-12) + (11-17) + (7-11) + (7-11) + (14-21)	1.8	1.8	2.5	1.8	1.8	3.5
(1.8 + 1.8 + 2.5) + (1.8 + 1.8 + 5.0)	(8-12) + (8-12) + (11-17) + (5-8) + (5-8) + (16-25)	1.8	1.8	2.5	1.8	1.8	5.0
(1.8 + 1.8 + 3.5) + (1.8 + 1.8 + 3.5)	(7-11) + (7-11) + (14-21) + (7-11) + (7-11) + (14-21)	1.8	1.8	3.5	1.8	1.8	3.5
(1.8 + 1.8 + 3.5) + (1.8 + 1.8 + 5.0)	(7-11) + (7-11) + (14-21) + (5-8) + (5-8) + (16-25)	1.8	1.8	3.5	1.8	1.8	5.0
(1.8 + 1.8 + 5.0) + (1.8 + 1.8 + 5.0)	(5-8) + (5-8) + (16-25) + (5-8) + (5-8) + (16-25)	1.8	1.8	5.0	1.8	1.8	5.0
(1.8 + 1.8 + 2.5) + (1.8 + 2.5 + 2.5)	(8-12) + (8-12) + (11-17) + (7-11) + (10-15) + (10-15)	1.8	1.8	2.5	1.8	2.5	2.5
(1.8 + 1.8 + 2.5) + (1.8 + 2.5 + 3.5)	(8-12) + (8-12) + (11-17) + (6-10) + (9-13) + (12-19)	1.8	1.8	2.5	1.8	2.5	3.5
(1.8 + 1.8 + 5.0) + (1.8 + 2.5 + 2.5)	(5-8) + (5-8) + (16-25) + (7-11) + (10-15) + (10-15)	1.8	1.8	5.0	1.8	2.5	2.5
(1.8 + 1.8 + 3.5) + (1.8 + 2.5 + 3.5)	(7-11) + (7-11) + (14-21) + (6-10) + (9-13) + (12-19)	1.8	1.8	3.5	1.8	2.5	3.5
(1.8 + 1.8 + 5.0) + (1.8 + 2.5 + 3.5)	(5-8) + (5-8) + (16-25) + (6-10) + (9-13) + (12-19)	1.8	1.8	5.0	1.8	2.5	3.5
(1.8 + 1.8 + 3.5) + (1.8 + 3.5 + 3.5)	(7-11) + (7-11) + (14-21) + (5-8) + (11-17) + (11-17)	1.8	1.8	3.5	1.8	3.5	3.5
(1.8 + 1.8 + 5.0) + (1.8 + 3.5 + 3.5)	(5-8) + (5-8) + (16-25) + (5-8) + (11-17) + (11-17)	1.8	1.8	5.0	1.8	3.5	3.5
(1.8 + 2.5 + 2.5) + (1.8 + 2.5 + 2.5)	(7-11) + (10-15) + (10-15) + (7-11) + (10-15) + (10-15)	1.8	2.5	2.5	1.8	2.5	2.5
(1.8 + 2.5 + 2.5) + (1.8 + 2.5 + 3.5)	(7-11) + (10-15) + (10-15) + (6-10) + (9-13) + (12-19)	1.8	2.5	2.5	1.8	2.5	3.5
(1.8 + 1.8 + 5.0) + (2.5 + 2.5 + 2.5)	(5-8) + (5-8) + (16-25) + (10-11) + (10-11) + (10-11)	1.8	1.8	5.0	2.5	2.5	2.5
(1.8 + 2.5 + 3.5) + (1.8 + 2.5 + 3.5)	(6-10) + (9-13) + (12-19) + (6-10) + (9-13) + (12-19)	1.8	2.5	3.5	1.8	2.5	3.5
(1.8 + 1.8 + 5.0) + (2.5 + 2.5 + 3.5)	(5-8) + (5-8) + (16-25) + (8-10) + (8-10) + (12-12)	1.8	1.8	5.0	2.5	2.5	3.5
(1.8 + 2.5 + 3.5) + (1.8 + 3.5 + 3.5)	(6-10) + (9-13) + (12-19) + (5-8) + (11-17) + (11-17)	1.8	2.5	3.5	1.8	3.5	3.5
(1.8 + 3.5 + 3.5) + (1.8 + 3.5 + 3.5)	(5-8) + (11-17) + (11-17) + (5-8) + (11-17) + (11-17)	1.8	3.5	3.5	1.8	3.5	3.5
(1.8 + 2.5 + 2.5) + (2.5 + 2.5 + 2.5)	(7-11) + (10-15) + (10-15) + (10-11) + (10-11) + (10-11)	1.8	2.5	2.5	2.5	2.5	2.5
(1.8 + 2.5 + 3.5) + (2.5 + 2.5 + 2.5)	(6-10) + (9-13) + (12-19) + (10-11) + (10-11) + (10-11)	1.8	2.5	3.5	2.5	2.5	2.5
(1.8 + 2.5 + 3.5) + (2.5 + 2.5 + 3.5)	(6-10) + (9-13) + (12-19) + (8-10) + (8-10) + (12-12)	1.8	2.5	3.5	2.5	2.5	3.5
(1.8 + 3.5 + 3.5) + (2.5 + 2.5 + 3.5)	(5-8) + (11-17) + (11-17) + (8-10) + (8-10) + (12-12)	1.8	3.5	3.5	2.5	2.5	3.5
(2.5 + 2.5 + 2.5) + (2.5 + 2.5 + 2.5)	(10-11) + (10-11) + (10-11) + (10-11) + (10-11) + (10-11)	2.5	2.5	2.5	2.5	2.5	2.5
(2.5 + 2.5 + 2.5) + (2.5 + 2.5 + 3.5)	(10-11) + (10-11) + (10-11) + (8-10) + (8-10) + (12-12)	2.5	2.5	2.5	2.5	2.5	3.5
(2.5 + 2.5 + 3.5) + (2.5 + 2.5 + 3.5)	(8-10) + (8-10) + (12-12) + (8-10) + (8-10) + (12-12)	2.5	2.5	3.5	2.5	2.5	3.5

INSTALLATION

PIPE LENGTH

- (1) Total 45m maximum pipe length for each refrigerant cycle (upper cycle and lower cycle).
- (2) Pipe length for one indoor unit : maximum 25m.

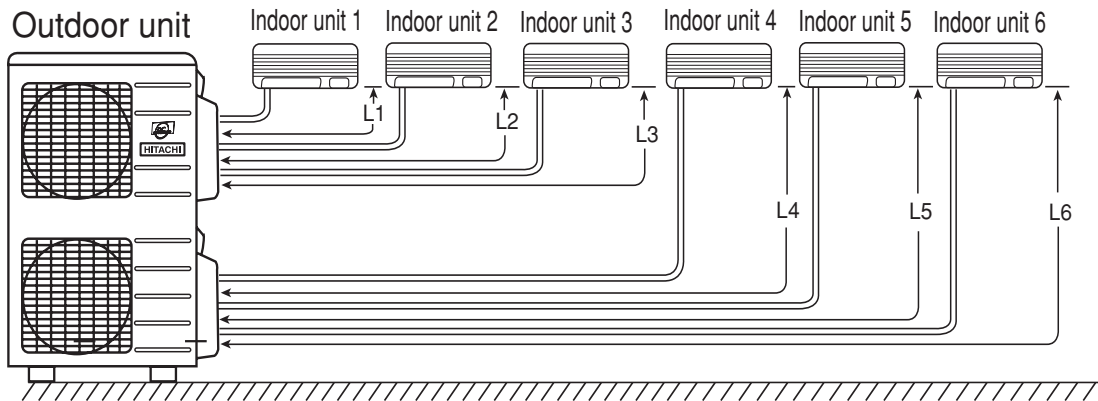

$(L1 + L2 + L3) = (L4 + L5 + L6) = \text{Maximum } 45\text{m}$
Minimum piping length for each indoor unit is 5m.
Maximum piping length for one indoor unit is 25m.

Height Difference between indoor units should be not more than 5m

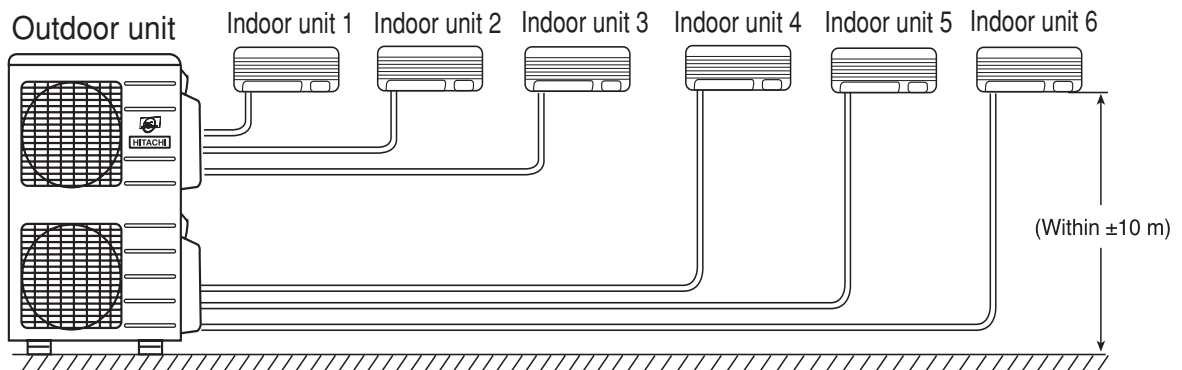

- To the outdoor unit, up to three indoor units can be connected until the total value of capacity from 5.0kW to 9.0kW for each refrigerant cycle (upper cycle and lower cycle).
- Make sure to connect to two or three indoor units for each refrigerant cycle.

MODEL: RAM-130QH5

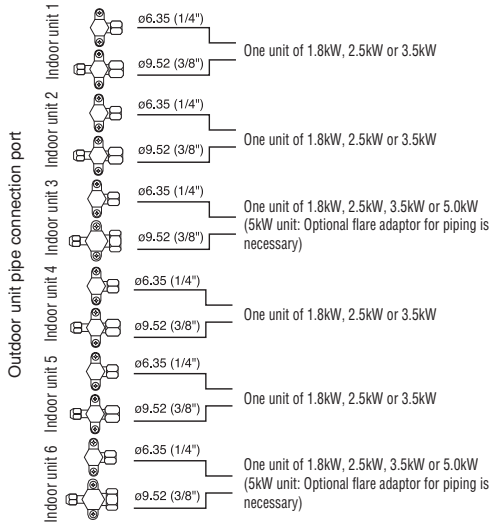

CAUTION

- This outdoor unit contain 2 difference refrigerant cycle with two compressors and two separated electrical.
- For refrigerant cycle at upper side of unit, shall be for connection for indoor 1, 2 and 3.
- For refrigerant cycle at lower side of unit, shall be for connection for indoor 4, 5 and 6.
- Each refrigerant cycle must be connected indoor units at least 2 connections.
- And connection no. 3 and no. 6 are compulsory. if not, there will be an icing at the condensor base during winter season.

Flare adaptor for piping

The flare adaptor for piping is required depending on combination of indoor units.

- ø9.52 (3/8") → ø12.7 (1/2") parts number TA261D-4 001

- Remove the side cover.
- For installation, refer as shown below.
- The space indicated with a ↔ mark is required to guarantee the air conditioner's performance. Install the airconditioner in a place big enough to provide ample space for servicing and repairs later on.

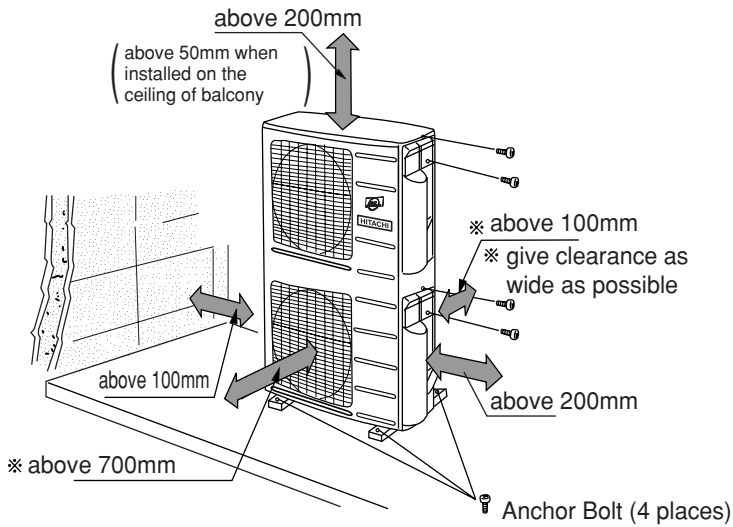

Connecting the pipe

- Install the unit in a stable place to minimize vibration or noise.
- After arranging the cord and pipes, secure them in place.

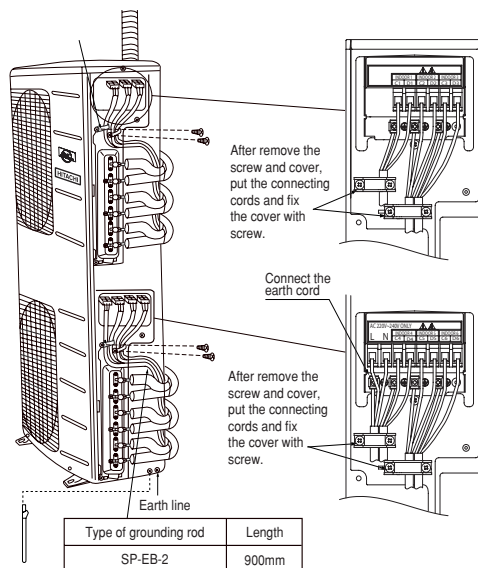

- Hold the handle of the side cover. Slide down and takeoff the corner hook, then pull. Reverse these steps when installing.

1. Remove flare nut from service valve.
2. Apply refrigerant oil to flare nut sections of service valve and pipings.
3. Match center of piping to large diameter side service valve and tank assembly, and tighten flare nut first by hand, then securely tighten using torque wrench.
4. Perform air purge and gas leak inspection.
5. Wrap the provided insulating material around side piping using vinyl tape.

Condensed water disposal of outdoor unit

- There is holes on the base of outdoor unit for condensed water to exhaust.
- To lead condensed water to the drain hole, place the outdoor unit on the mounting stand (optional) or on blocks to raise its level more than 100mm from the ground surface. Connect the drain pipe as shown in the figure. Cover two other water drain holes with the bushings included. (To install a bushing, push in both ends of the bushing so that it aligns with the drain hole.)
- When connecting the drain pipe, make sure that the bushing does not lift off or deviate from the base.
- Install the outdoor unit on a stable, flat surface and check to see that the condensed water drains.

When Using and Installing in Cold Areas

When the air conditioner is used in low temperature and in snowy conditions, water from the heat exchanger may freeze on the base surface to cause poor drainage. When using the air conditioner in such areas, do not install the bushings. Keep a minimum of 250mm between the drain hole and the ground. When using the drain pipe, consult your sales agent.

※ For more details, refer to the Installation Manual for Cold Areas.

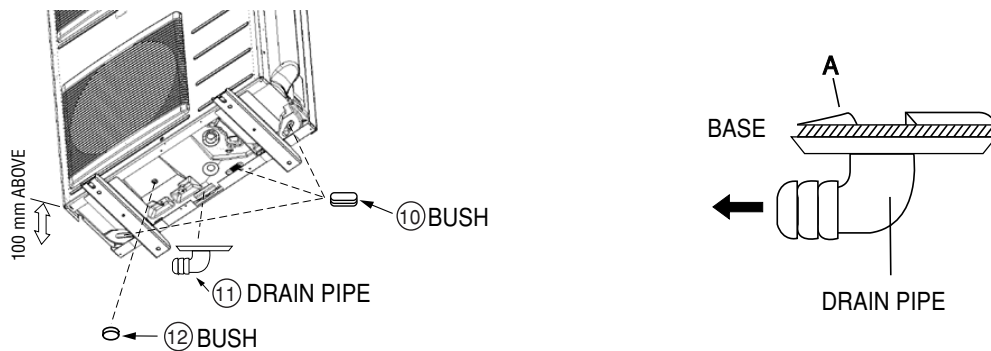

Connection of the connecting cords and power cord. (Outdoor unit)

RAM-130QH5

⚠ WARNING

- Connecting cord should be connected according to Fig.1, that the Indoor unit No. shall match with terminal board No. of Outdoor unit.
- Be sure to fix the connecting cord with the band as shown below. Otherwise water leakage causes short circuit or faults.

Type of grounding rod	Length
SP-EB-2	900mm

⚠ CAUTION

- If earth line cannot be taken from the power supply connection, use the optional grounding rod to do earthing.

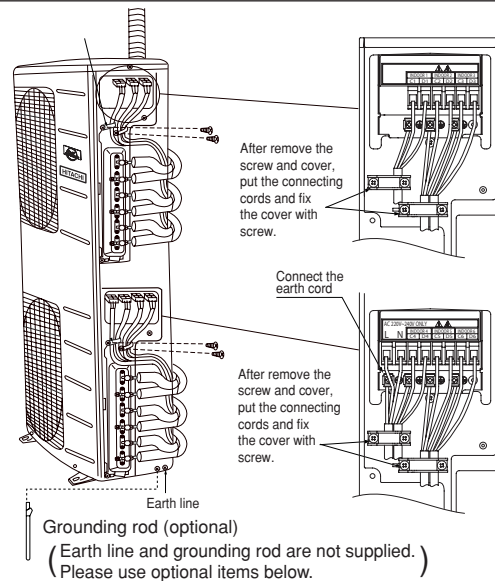

Wiring Pattern
Indoor Unit

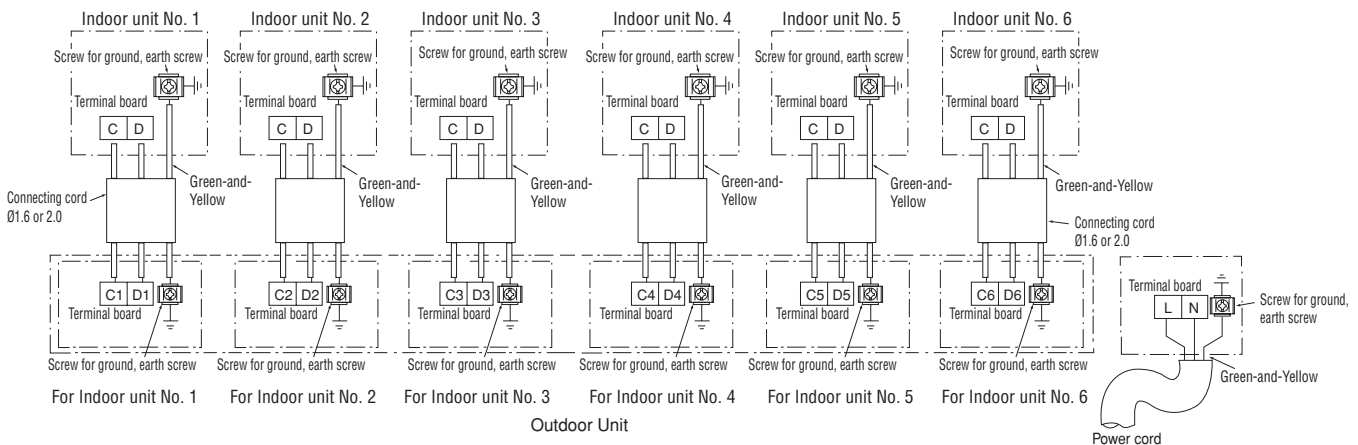

⚠ WARNING

Connection of the power cord and connecting cord

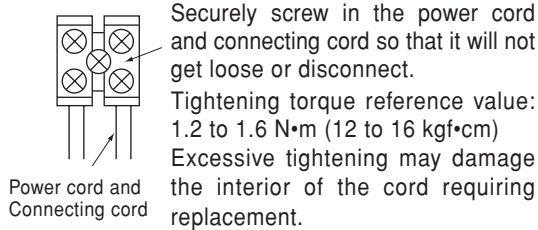

⚠ CAUTION

- To prevent a connection error, connecting cords should be bundled and taped to each respective pipe. If connecting cords are mixed with other indoor units, a refrigeration cycle abnormality may occur, causing dripping.

- When putting two connecting cords through the band.

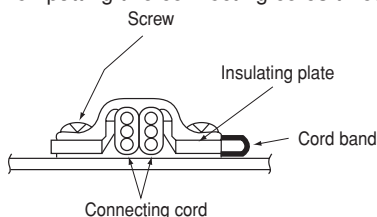

⚠ WARNING

- Leave some space in the connecting cord for maintenance purpose and be sure to secure it with the cord band.
- Secure the connecting cord along the coated part of the wire using the cord band. Do not exert pressure on the wire as this may cause overheating or fire.

- Hold the handle of the side cover, slide down and take off the corner hook, then pull. Reverse these steps when installing.

CONSTRUCTION AND DIMENSIONAL DIAGRAM

MODEL RAM-130QH5

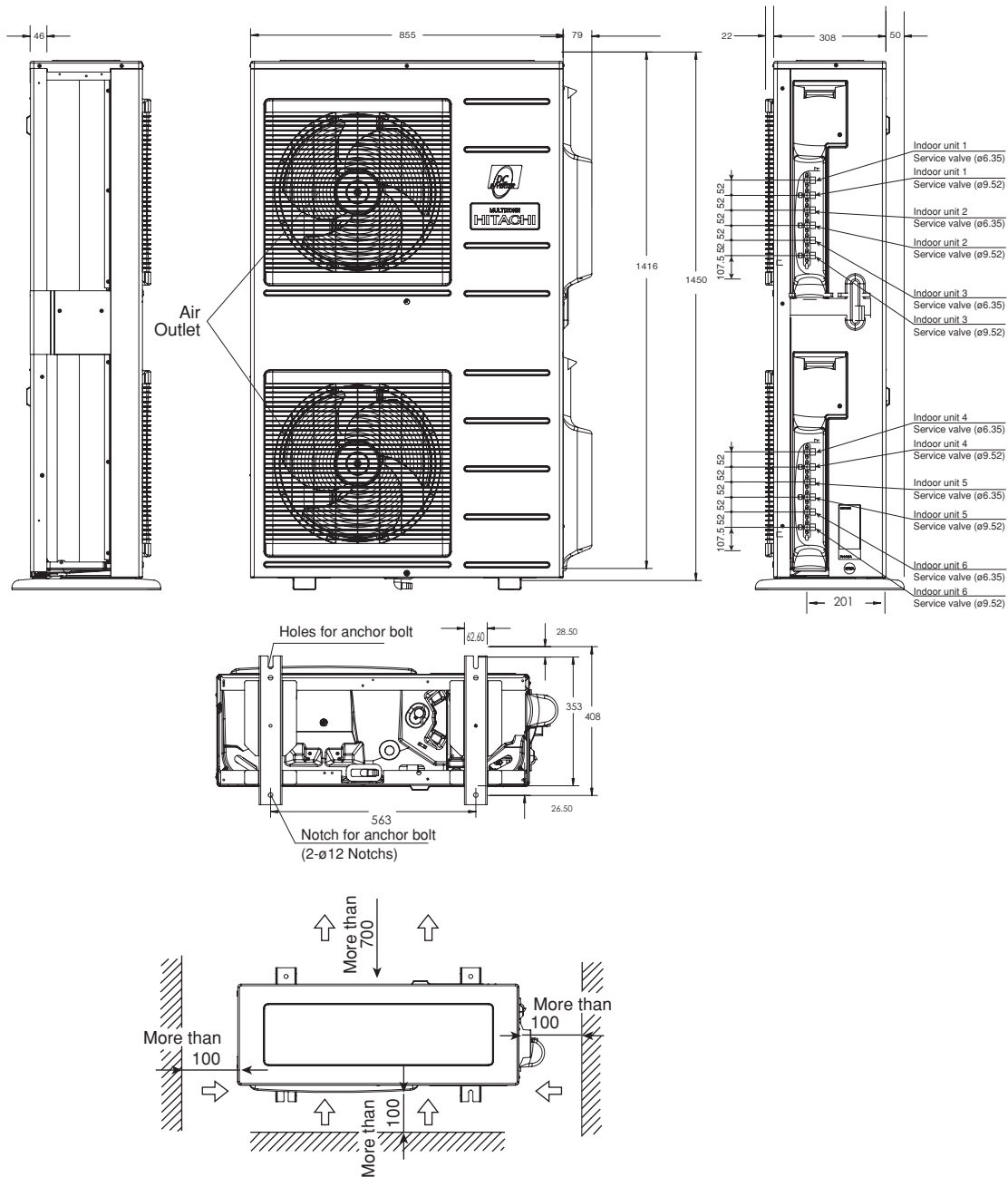

Service space

Note:

1. Insulated pipes should be used for both small and large diameter pipes.
2. Piping length should be within 25m for one room and within 45m in total.
3. Height difference of piping between indoor unit and outdoor unit should be within 10m.
4. Overhead clearance of outdoor unit should be 200mm to allow servicing.
5. For electrical connection, please refer to the installation manual.

ATTENTION

During service, before opening the side cover, please switch off power supply.

MAIN PARTS COMPONENT

FAN MOTOR

Fan Motor Specifications

MODEL		RAM-130QH5
POWER SOURCE		DC : 140-330V
OUTPUT		40W
CONNECTION		<p>(Control circuit built in)</p>
RESISTANCE VALUE (Ω)	20°C (68°F)	—
	75°C (167°F)	—

BLU : BLUE

YEL : YELLOW

BRN : BROWN

WHT : WHITE

GRY : GRAY

ORN : ORANGE

GRN : GREEN

RED : RED

BLK : BLACK

PNK : PINK

VIO : VIOLET

COMPRESSOR

Compressor Motor Specifications

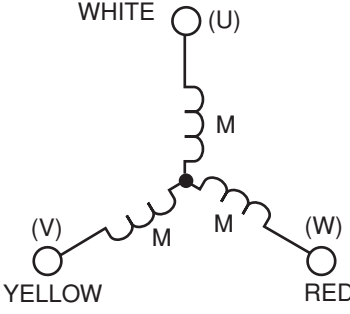
MODEL		RAM-130QH5
COMPRESSOR MODEL		JU1013D2
PHASE		SINGLE
RATED VOLTAGE		DC: 280-330V
RATED FREQUENCY		50Hz
POLE NUMBER		4
CONNECTION		
RESISTANCE VALUE (Ω)	25°C (68°F)	2M = 1.063
	75°C (167°F)	2M = 1.268

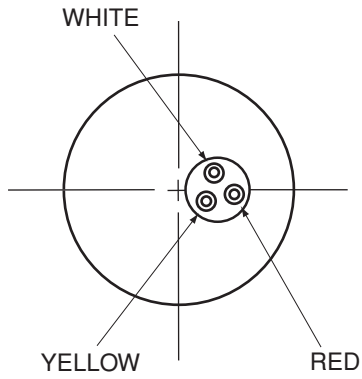

CAPACITY DIAGRAM (RELATED TO THE AMBIENT TEMPERATURE)

MODEL : RAM-130QH5

COOLING CAPACITY (ROOM TEMPERATURE 27°C) WHEN SIX INDOOR UNITS OPERATE

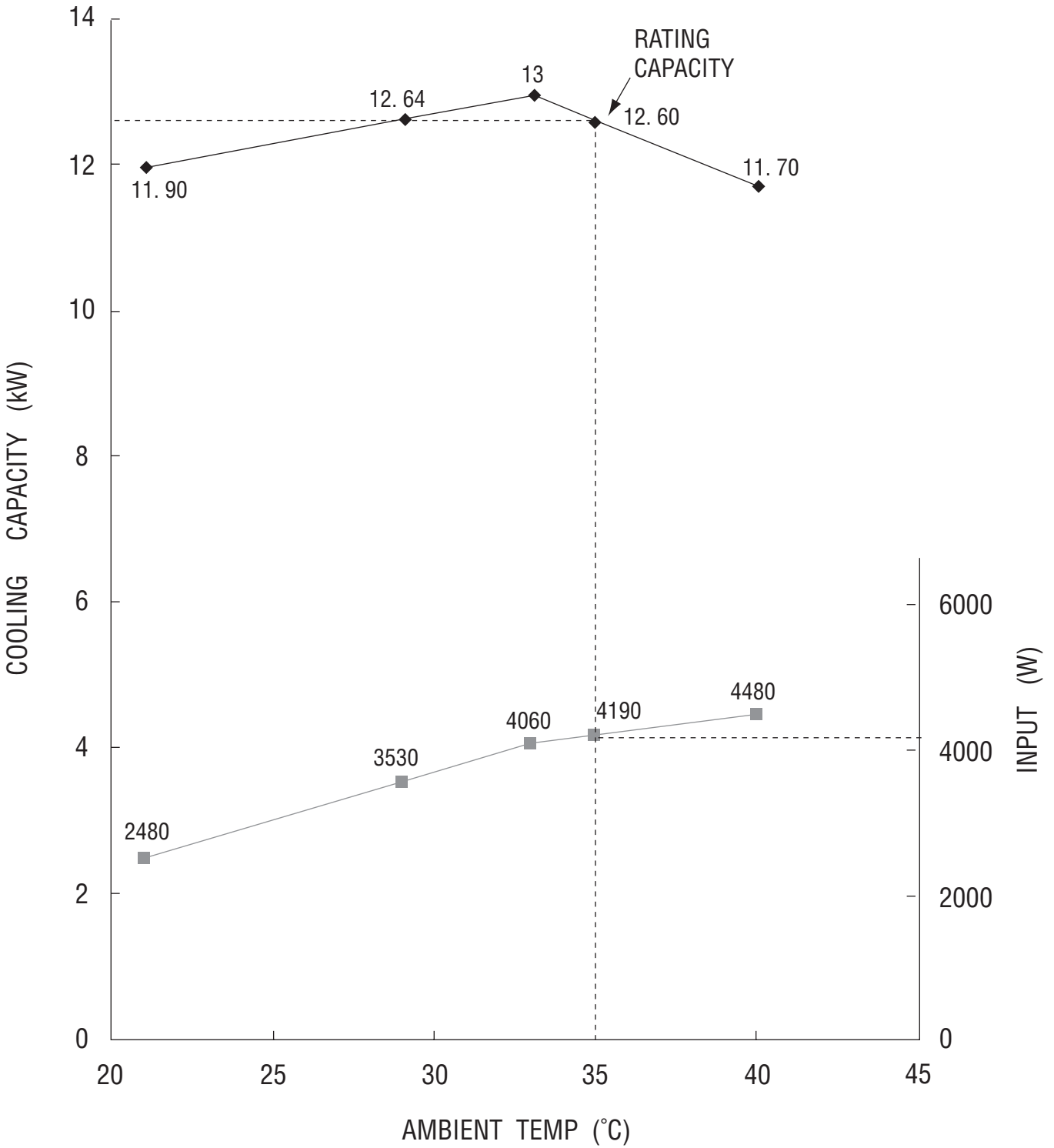

CAPACITY DIAGRAM (RELATED TO THE AMBIENT TEMPERATURE)

MODEL : RAM-130QH5

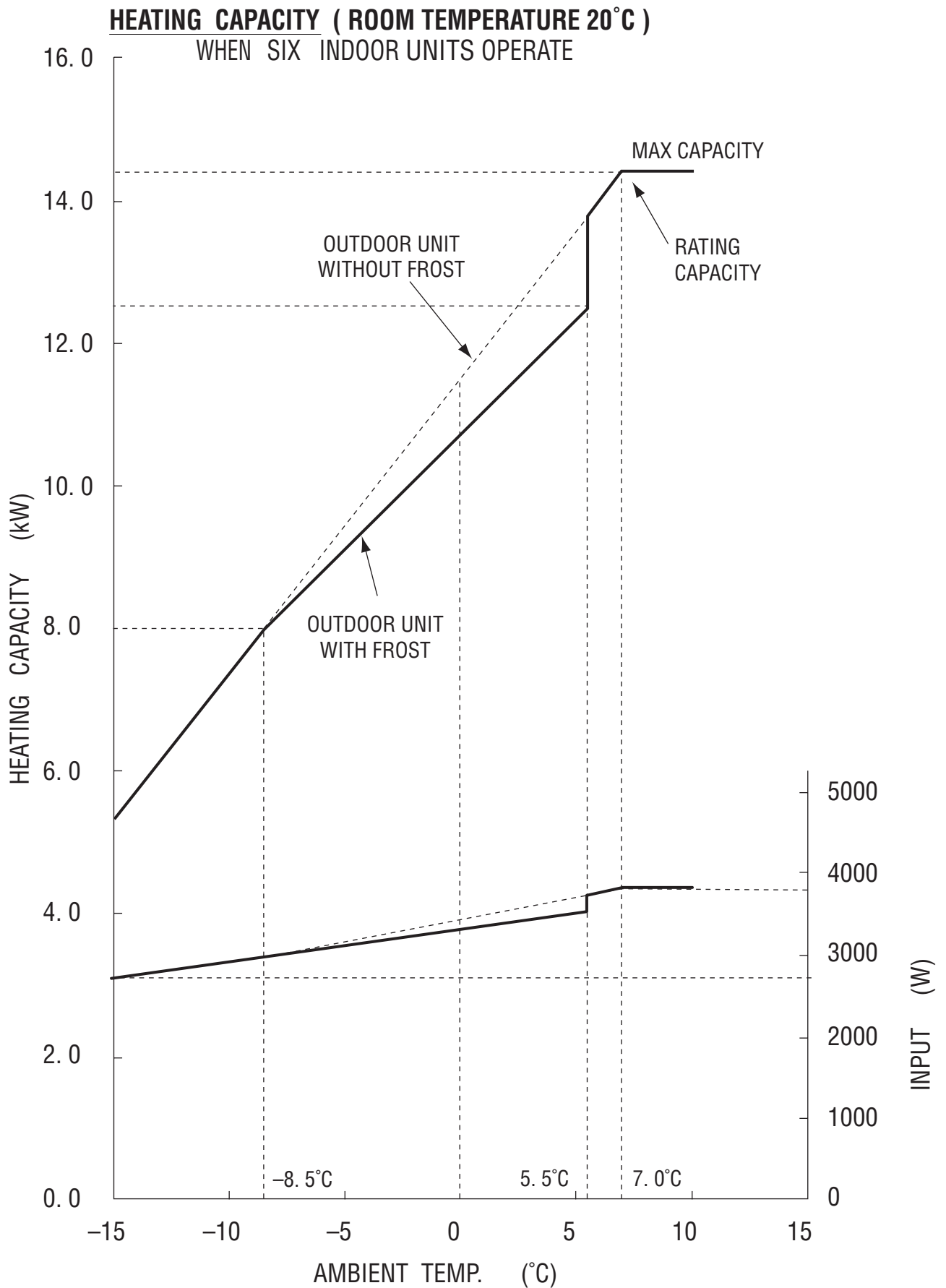

CAPACITY DIAGRAM (RELATED TO THE PIPING LENGTH)

MODEL : RAM-130QH5

COOLING

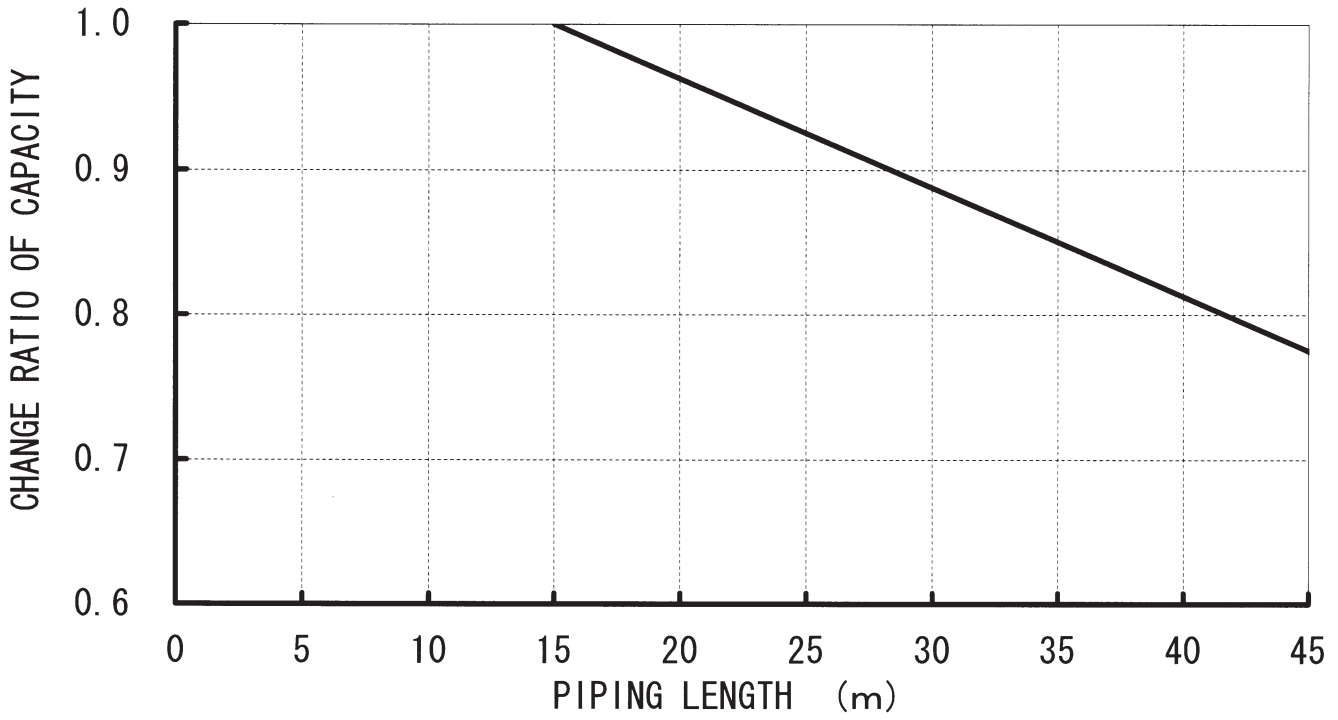

HEATING

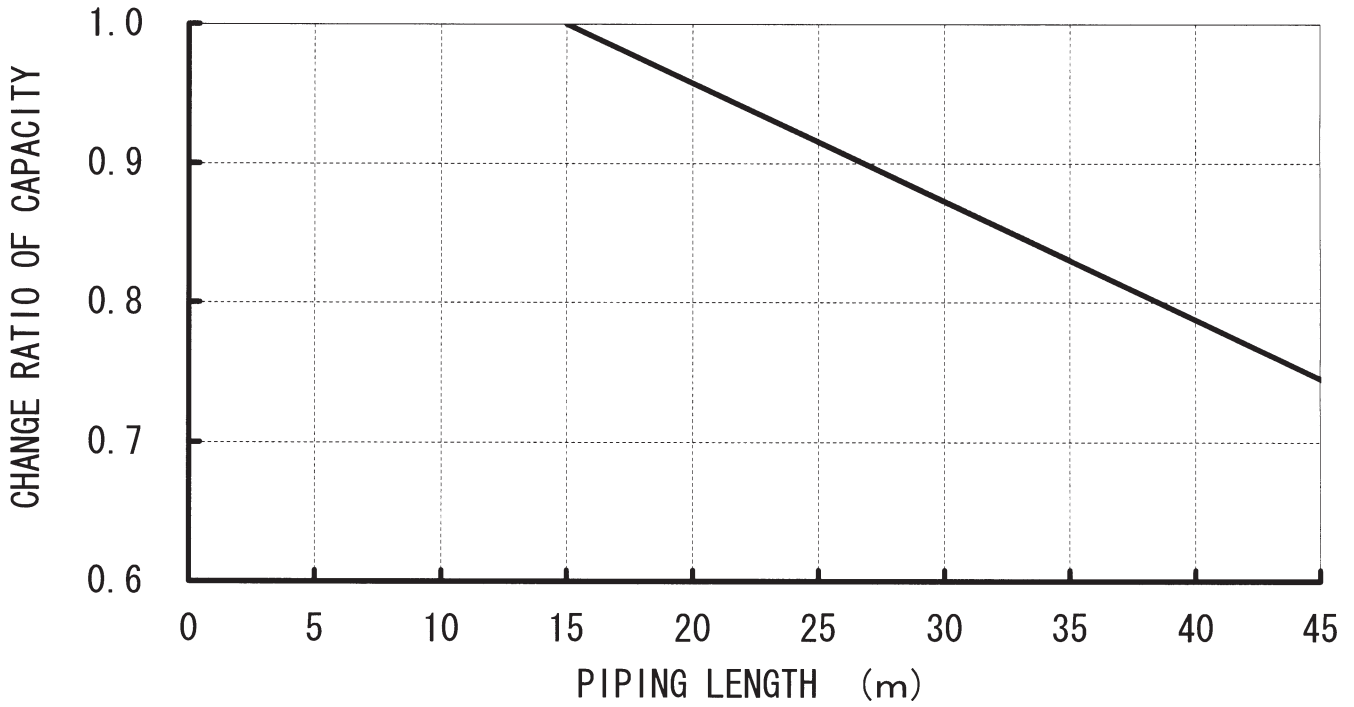

SOUND PRESSURE LEVEL

MODEL : RAM-130QH5 (Heating)

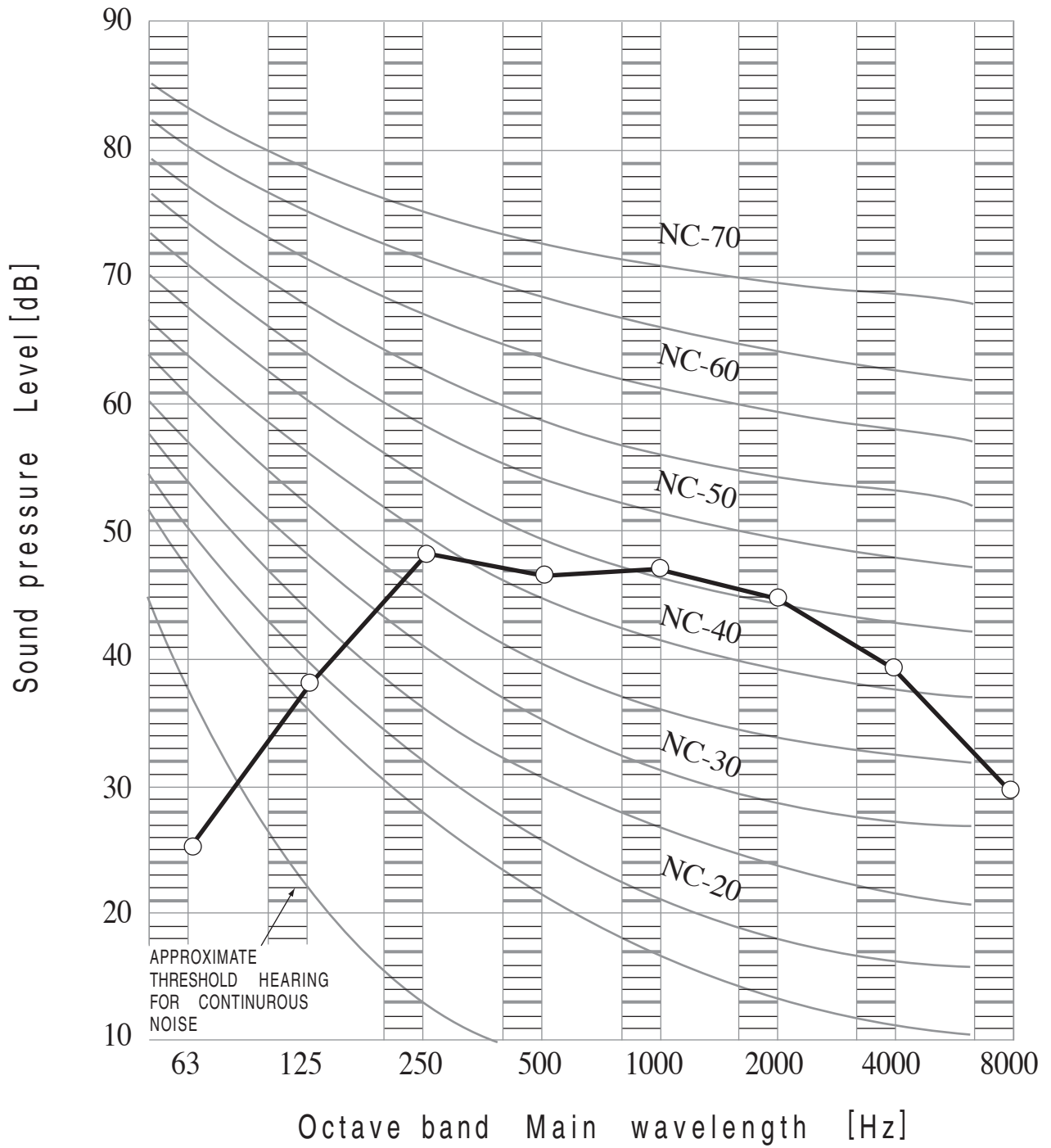

SOUND PRESSURE LEVEL

MODEL : RAM-130QH5 (Cooling)

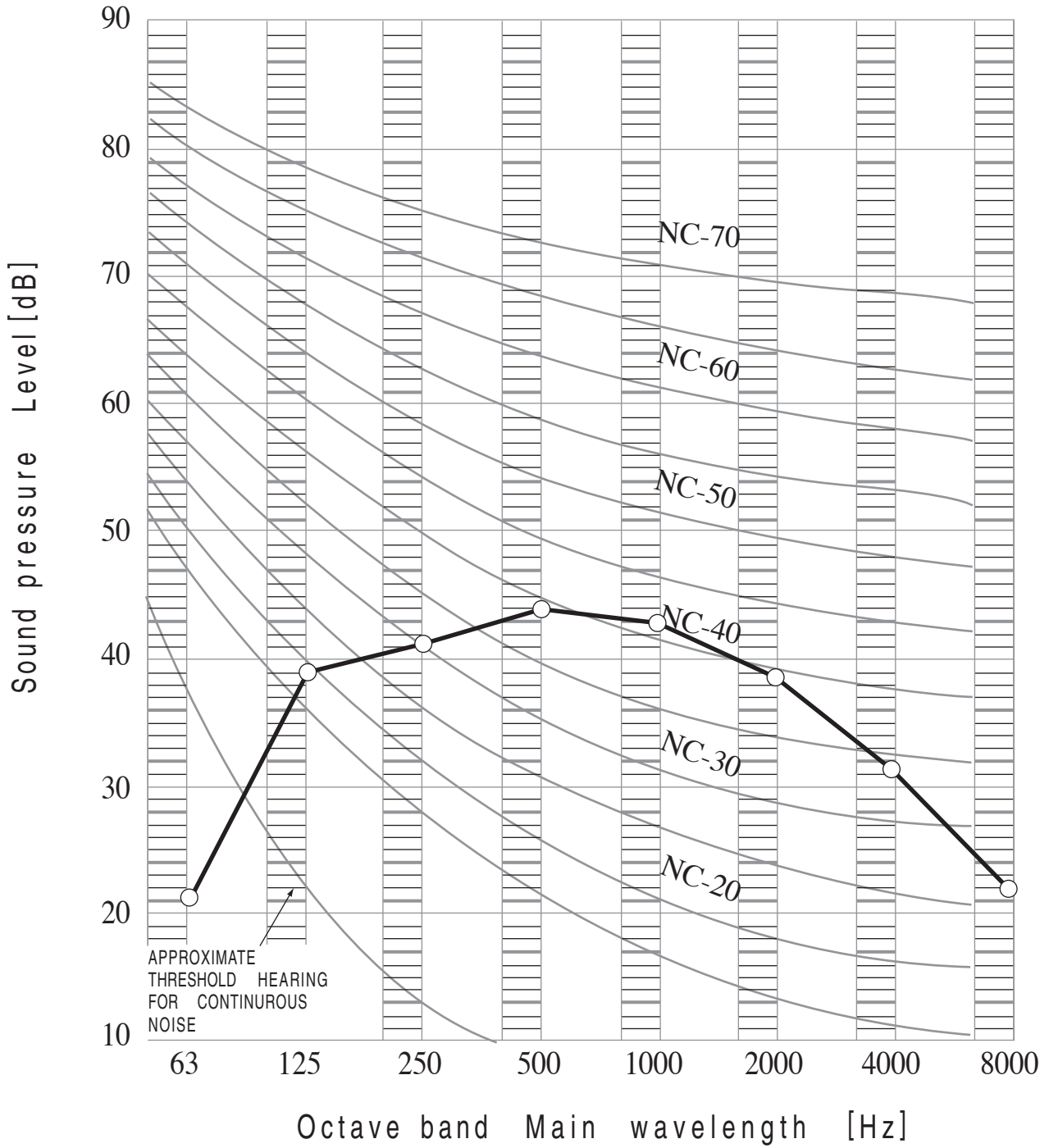

WIRING DIAGRAM

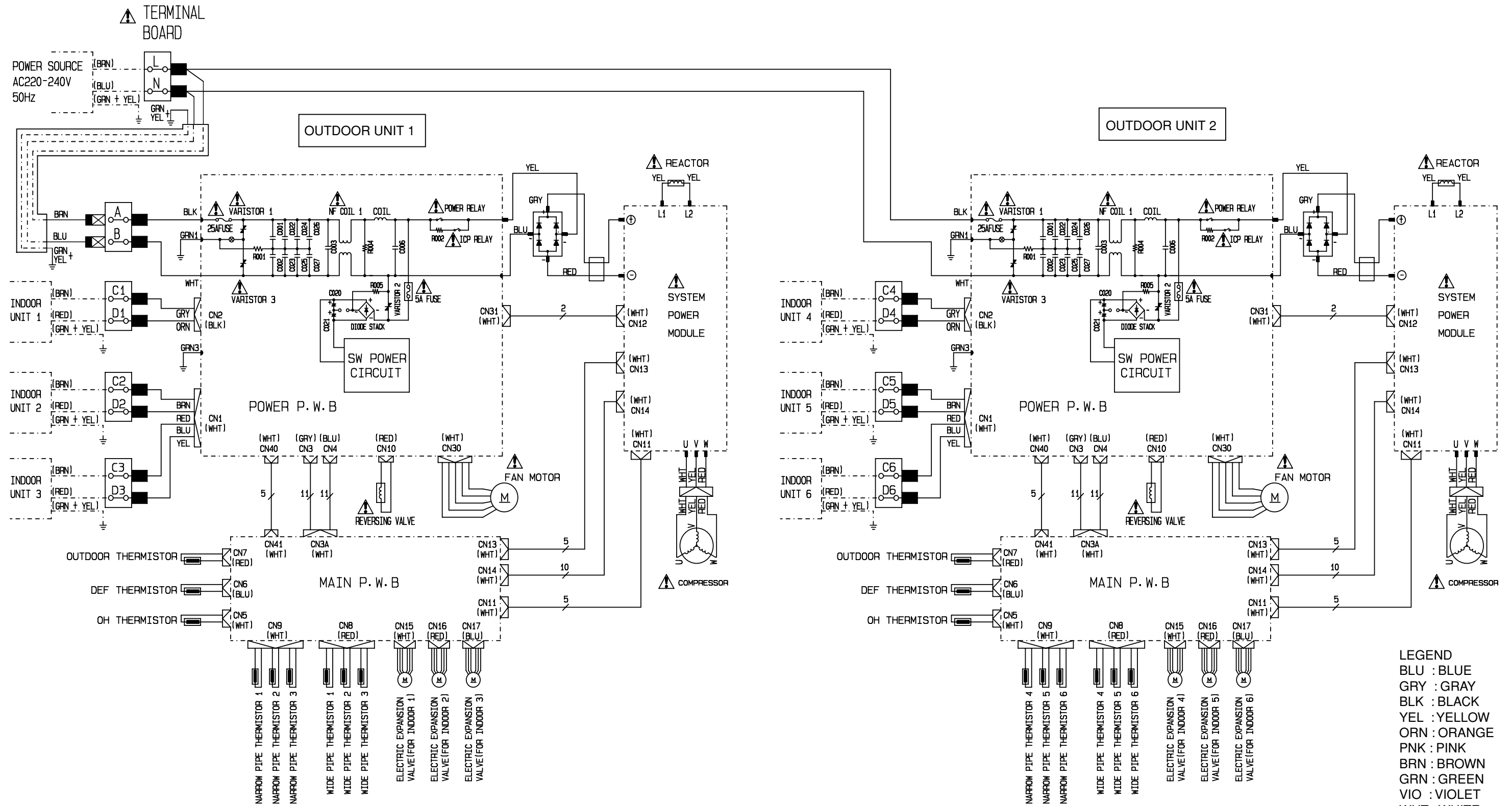

CAUTION

The marked parts are very important ones for safety

CIRCUIT DIAGRAM

Remote Control

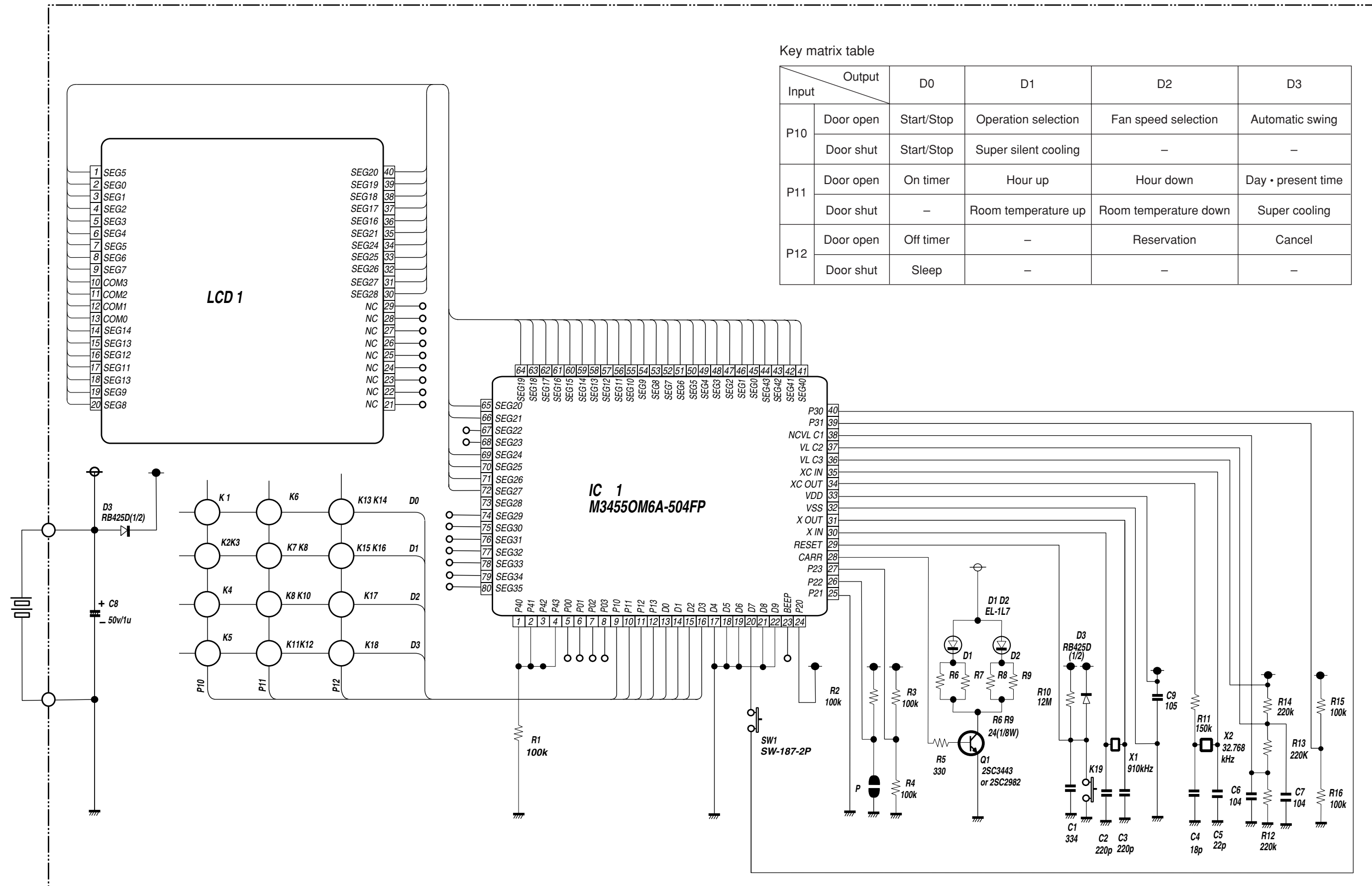

Key matrix table

Input \ Output		D0	D1	D2	D3
		D0	D1	D2	D3
P10	Door open	Start/Stop	Operation selection	Fan speed selection	Automatic swing
	Door shut	Start/Stop	Super silent cooling	-	-
P11	Door open	On timer	Hour up	Hour down	Day · present time
	Door shut	-	Room temperature up	Room temperature down	Super cooling
P12	Door open	Off timer	-	Reservation	Cancel
	Door shut	Sleep	-	-	-

CIRCUIT DIAGRAM

OUTDOOR UNIT 1

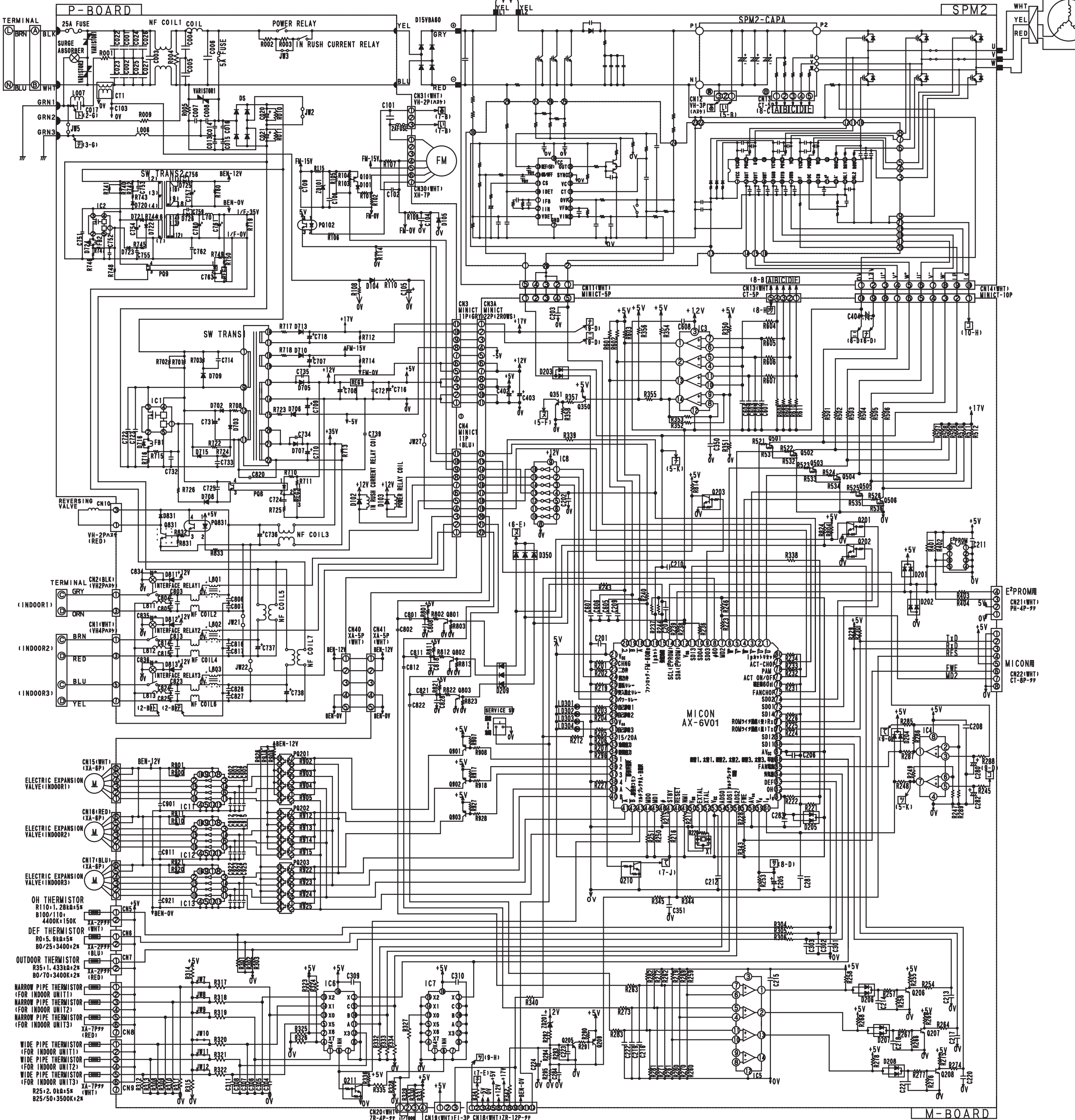

RESISTOR

MARK	RESISTANCE	TOLERANCE	TEMP. COEFF.	POWER	TYPE
R001	100 Ω	±1%		0.25W	A
R002	100 Ω	±1%		0.25W	A
R003	100 Ω	±1%		0.25W	A
R004	470 Ω	±1%		0.25W	A
R005	2.2 kΩ	±1%		0.25W	A
R006	10 kΩ	±1%		0.25W	A
R007	47 kΩ	±1%		0.25W	A
R008	100 kΩ	±1%		0.25W	A
R009	200 kΩ	±1%		0.25W	A
R010	470 kΩ	±1%		0.25W	A
R011	1 kΩ	±1%		0.25W	A
R012	2 kΩ	±1%		0.25W	A
R013	5 kΩ	±1%		0.25W	A
R014	10 kΩ	±1%		0.25W	A
R015	20 kΩ	±1%		0.25W	A
R016	50 kΩ	±1%		0.25W	A
R017	100 kΩ	±1%		0.25W	A
R018	200 kΩ	±1%		0.25W	A
R019	500 kΩ	±1%		0.25W	A
R020	1 MΩ	±1%		0.25W	A
R021	2 MΩ	±1%		0.25W	A
R022	5 MΩ	±1%		0.25W	A
R023	10 MΩ	±1%		0.25W	A
R024	20 MΩ	±1%		0.25W	A
R025	50 MΩ	±1%		0.25W	A
R026	100 MΩ	±1%		0.25W	A
R027	200 MΩ	±1%		0.25W	A
R028	500 MΩ	±1%		0.25W	A
R029	1 MΩ	±1%		0.25W	A
R030	2 MΩ	±1%		0.25W	A
R031	5 MΩ	±1%		0.25W	A
R032	10 MΩ	±1%		0.25W	A
R033	20 MΩ	±1%		0.25W	A
R034	50 MΩ	±1%		0.25W	A
R035	100 MΩ	±1%		0.25W	A
R036	200 MΩ	±1%		0.25W	A
R037	500 MΩ	±1%		0.25W	A
R038	1 MΩ	±1%		0.25W	A
R039	2 MΩ	±1%		0.25W	A
R040	5 MΩ	±1%		0.25W	A
R041	10 MΩ	±1%		0.25W	A
R042	20 MΩ	±1%		0.25W	A
R043	50 MΩ	±1%		0.25W	A
R044	100 MΩ	±1%		0.25W	A
R045	200 MΩ	±1%		0.25W	A
R046	500 MΩ	±1%		0.25W	A
R047	1 MΩ	±1%		0.25W	A
R048	2 MΩ	±1%		0.25W	A
R049	5 MΩ	±1%		0.25W	A
R050	10 MΩ	±1%		0.25W	A

RESISTOR

MARK	RESISTANCE	TOLERANCE	TEMP. COEFF.	POWER	TYPE
R308	100 Ω	±1%		0.25W	A
R309	200 Ω	±1%		0.25W	A
R310	500 Ω	±1%		0.25W	A
R311	1 kΩ	±1%		0.25W	A
R312	2 kΩ	±1%		0.25W	A
R313	5 kΩ	±1%		0.25W	A
R314	10 kΩ	±1%		0.25W	A
R315	20 kΩ	±1%		0.25W	A
R316	50 kΩ	±1%		0.25W	A
R317	100 kΩ	±1%		0.25W	A
R318	200 kΩ	±1%		0.25W	A
R319	500 kΩ	±1%		0.25W	A
R320	1 MΩ	±1%		0.25W	A
R321	2 MΩ	±1%		0.25W	A
R322	5 MΩ	±1%		0.25W	A
R323	10 MΩ	±1%		0.25W	A
R324	20 MΩ	±1%		0.25W	A
R325	50 MΩ	±1%		0.25W	A
R326	100 MΩ	±1%		0.25W	A
R327	200 MΩ	±1%		0.25W	A
R328	500 MΩ	±1%		0.25W	A
R329	1 MΩ	±1%		0.25W	A
R330	2 MΩ	±1%		0.25W	A
R331	5 MΩ	±1%		0.25W	A
R332	10 MΩ	±1%		0.25W	A
R333	20 MΩ	±1%		0.25W	A
R334	50 MΩ	±1%		0.25W	A
R335	100 MΩ	±1%		0.25W	A
R336	200 MΩ	±1%		0.25W	A
R337	500 MΩ	±1%		0.25W	A
R338	1 MΩ	±1%		0.25W	A
R339	2 MΩ	±1%		0.25W	A
R340	5 MΩ	±1%		0.25W	A
R341	10 MΩ	±1%		0.25W	A
R342	20 MΩ	±1%		0.25W	A
R343	50 MΩ	±1%		0.25W	A
R344	100 MΩ	±1%		0.25W	A
R345	200 MΩ	±1%		0.25W	A
R346	500 MΩ	±1%		0.25W	A
R347	1 MΩ	±1%		0.25W	A
R348	2 MΩ	±1%		0.25W	A
R349	5 MΩ	±1%		0.25W	A
R350	10 MΩ	±1%		0.25W	A

RESISTOR

MARK	RESISTANCE	TOLERANCE	TEMP. COEFF.	POWER	TYPE
R749	4.7 kΩ	±1%		0.25W	A
R750	150 Ω	±1%		0.25W	A
R751	100 Ω	±1%		0.25W	A
R752	200 Ω	±1%		0.25W	A
R753	500 Ω	±1%		0.25W	A
R754	1 kΩ	±1%		0.25W	A
R755	2 kΩ	±1%		0.25W	A
R756	5 kΩ	±1%		0.25W	A
R757	10 kΩ	±1%		0.25W	A
R758	20 kΩ	±1%		0.25W	A
R759	50 kΩ	±1%		0.25W	A
R760	100 kΩ	±1%		0.25W	A
R761	200 kΩ	±1%		0.25W	A
R762	500 kΩ	±1%		0.25W	A
R763	1 MΩ	±1%		0.25W	A
R764	2 MΩ	±1%		0.25W	A
R765	5 MΩ	±1%		0.25W	A
R766	10 MΩ	±1%		0.25W	A
R767	20 MΩ	±1%		0.25W	A
R768	50 MΩ	±1%		0.25W	A
R769	100 MΩ	±1%		0.25W	A
R770	200 MΩ	±1%		0.25W	A
R771	500 MΩ	±1%		0.25W	A
R772	1 MΩ	±1%		0.25W	A
R773	2 MΩ	±1%		0.25W	A
R774	5 MΩ	±1%		0.25W	A
R775	10 MΩ	±1%		0.25W	A
R776	20 MΩ	±1%		0.25W	A
R777	50 MΩ	±1%		0.25W	A
R778	100 MΩ	±1%		0.25W	A
R779	200 MΩ	±1%		0.25W	A
R780	500 MΩ	±1%		0.25W	A
R781	1 MΩ	±1%		0.25W	A
R782	2 MΩ	±1%		0.25W	A
R783	5 MΩ	±1%		0.25W	A
R784	10 MΩ	±1%		0.25W	A

CAPACITOR

MARK	VALUE	TOLERANCE	VOLTAJE	TEMP. COEFF.	TYPE
C311	1 μF	±5%	50V		C
C350	100 pF	±5%	50V		C
C351	0.01 μF	±5%	50V		C
C402	100 pF	±5%	50V		C
C403	100 pF	±5%	50V		C
C404	33 pF	±5%	50V		C
C601	680 pF	±5%	50V		C
C602	880 pF	±5%	50V		C
C603	880 pF	±5%	50V		C
C604	880 pF	±5%	50V		C
C605	1000 pF	±5%	50V		C
C606	1000 pF	±5%	50V		C
C607	1000 pF	±5%	50V		C
C608	0.1 μF	±5%	50V		C
C707	330 pF	±5%	50V		C
C708	330 pF	±5%	50V		C
C709	100 pF	±5%	50V		C
C710	330 pF	±5%	50V		C
C711	0.1 μF	±5%	50V		C
C712	0.1 μF	±5%	50V		C
C713	0.1 μF	±5%	50V		C
C714	0.1 μF	±5%	50V		C
C715	0.1 μF	±5%	50V		C
C716	330 pF	±5%	50V		C
C717	220 pF	±5%	50V		C
C718	220 pF	±5%	50V		C
C719	330 pF	±5%	50V		C
C720	330 pF	±5%	50V		C
C721	0.1 μF	±5%	50V		C
C722	0.1 μF	±5%	50V		C
C723	0.1 μF	±5%	50V		C
C724	0.1 μF	±5%	50V		C
C725	0.1 μF	±5%	50V		C
C726	0.1 μF	±5%	50V		C
C727	0.1 μF	±5%	50V		C
C728	0.1 μF	±5%	50V		C
C729	0.1 μF	±5%	50V		C
C730	0.1 μF	±5%	50V		C
C731	330 pF	±5%	50V		C
C732	470 pF	±5%	50V		C
C733	1000 pF	±5%	50V		C
C734	1000 pF	±5%	50V		C
C735	0.1 μF	±5%	50V		C
C736	680 pF	±5%	50V		C
C737	680 pF	±5%	50V		C
C738	680 pF	±5%	50V		C
C739	470 pF	±5%	50V		C
C740	0.1 μF	±5%	50V		C
C741	0.1 μF	±5%	50V		C
C742	0.1 μF	±5%	50V		C
C743	0.1 μF	±5%	50V		C
C744	0.1 μF	±5%	50V		C
C745	0.1 μF	±5%	50V		C
C746	0.1 μF	±5%	50V		C
C747	0.1 μF	±5%	50V		C
C748	0.1 μF	±5%	50V		C
C749	0.1 μF	±5%	50V		C
C750	0.1 μF	±5%	50V		C

TRANSISTOR

MARK	MODEL	TYPE	PACKAGE
Q101	2SA735	NPN	TO-18
Q102	2SA735	NPN	TO-18
Q103	2SA735	NPN	TO-18
Q104	2SA735	NPN	TO-18
Q105	2SA735	NPN	TO-18
Q106	2SA735	NPN	TO-18
Q107	2SA735	NPN	TO-18
Q108	2SA735	NPN	TO-18
Q109	2SA735	NPN	TO-18
Q110	2SA735	NPN	TO-18
Q111	2SA735	NPN	TO-18
Q112	2SA735	NPN	TO-18
Q113	2SA735	NPN	TO-18
Q114	2SA735	NPN	TO-18
Q115	2SA735	NPN	TO-18
Q116	2SA735	NPN	TO-18
Q117	2SA735	NPN	TO-18
Q118	2SA735	NPN	TO-18
Q119	2SA735	NPN	TO-18
Q120	2SA735	NPN	TO-18
Q121	2SA735	NPN	TO-18
Q122	2SA735	NPN	TO-18
Q123	2SA735	NPN	TO-18
Q124	2SA735	NPN	TO-18
Q125	2SA735	NPN	TO-18
Q126	2SA735	NPN	TO-18
Q127	2SA735	NPN	TO-18
Q128	2SA735	NPN	TO-18
Q129	2SA735	NPN	TO-18
Q130	2SA735	NPN	TO-18
Q131	2SA735	NPN	TO-18
Q132	2SA735	NPN	TO-18
Q133	2SA735	NPN	TO-18
Q134	2SA735	NPN	TO-18
Q135	2SA735	NPN	TO-18
Q136	2SA735	NPN	TO-18
Q137	2SA735	NPN	TO-18
Q138	2SA735	NPN	TO-18
Q139	2SA735	NPN	TO-18
Q140	2SA735	NPN	TO-18

IC

MARK	MODEL	TYPE	PACKAGE
U100	AX-6500	MCU	TO-18
U101	AX-6500	MCU	TO-18
U102	AX-6500	MCU	TO-18
U103	AX-6500	MCU	TO-18
U104	AX-6500	MCU	TO-18
U105	AX-6500	MCU	TO-18
U106	AX-6500	MCU	TO-18
U107	AX-6500	MCU	TO-18
U108	AX-6500	MCU	TO-18
U109	AX-6500	MCU	TO-18
U110	AX-6500	MCU	TO-18
U111	AX-6500	MCU	TO-18
U112	AX-6500	MCU	TO-18
U113	AX-6500	MCU	TO-18
U114	AX-6500	MCU	TO-18
U115	AX-6500	MCU	TO-18
U116	AX-6500	MCU	TO-18
U117	AX-6500	MCU	TO-18
U118	AX-6500	MCU	TO-18
U119	AX-6500	MCU	TO-18
U120	AX-6500	MCU	TO-18
U121	AX-6500	MCU	TO-18
U122			

CIRCUIT DIAGRAM

OUTDOOR UNIT 2

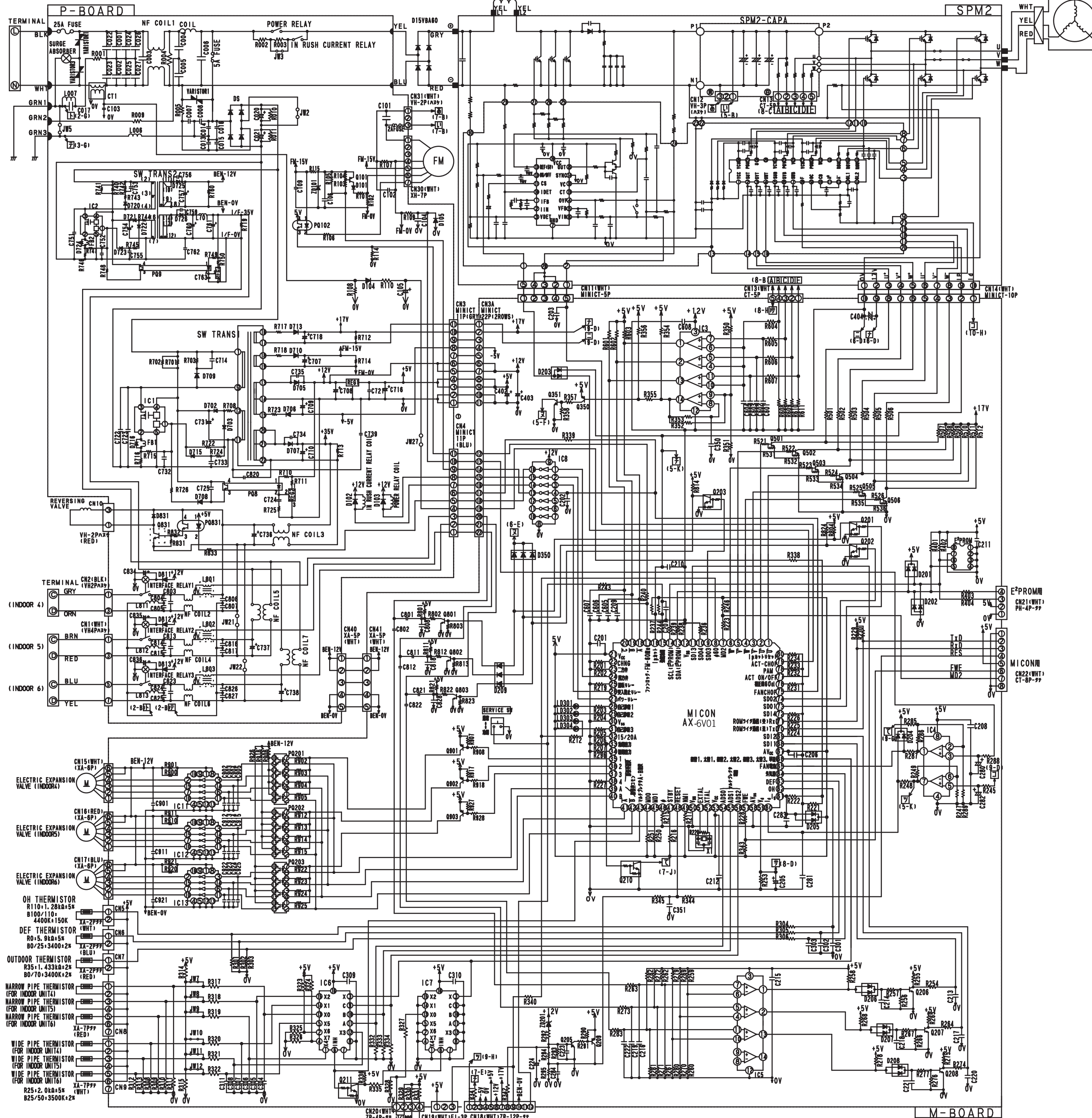

MOUNTING
 R -- RADIAL
 C -- CHIP
 A -- AXIAL
 H -- HAND INSERT

PCB SET
 NO MARKING ---M-BOARDS
 P---#P-BOARDS

TYPE
 F -- FILM
 C -- CERAMIC
 D -- ELECTROLYTIC

RESISTOR				RESISTOR				RESISTOR				CAPACITOR				TRANSISTOR				IC							
MARK	RATING	W	W	MARK	RATING	W	W	MARK	RATING	W	W	MARK	RATING	W	W	MARK	MODEL	W	W	MARK	MODEL	W	W	MARK	MODEL	W	W
R001	100 Ω	1/4 W	1/4 W	R001	100 Ω	1/4 W	1/4 W	R001	100 Ω	1/4 W	1/4 W	C001	100 nF	50 V	50 V	2N2222	2N2222	180 μm	180 μm	74V01	74V01	180 μm	180 μm	74V01	74V01	180 μm	180 μm

BLOCK DIAGRAM

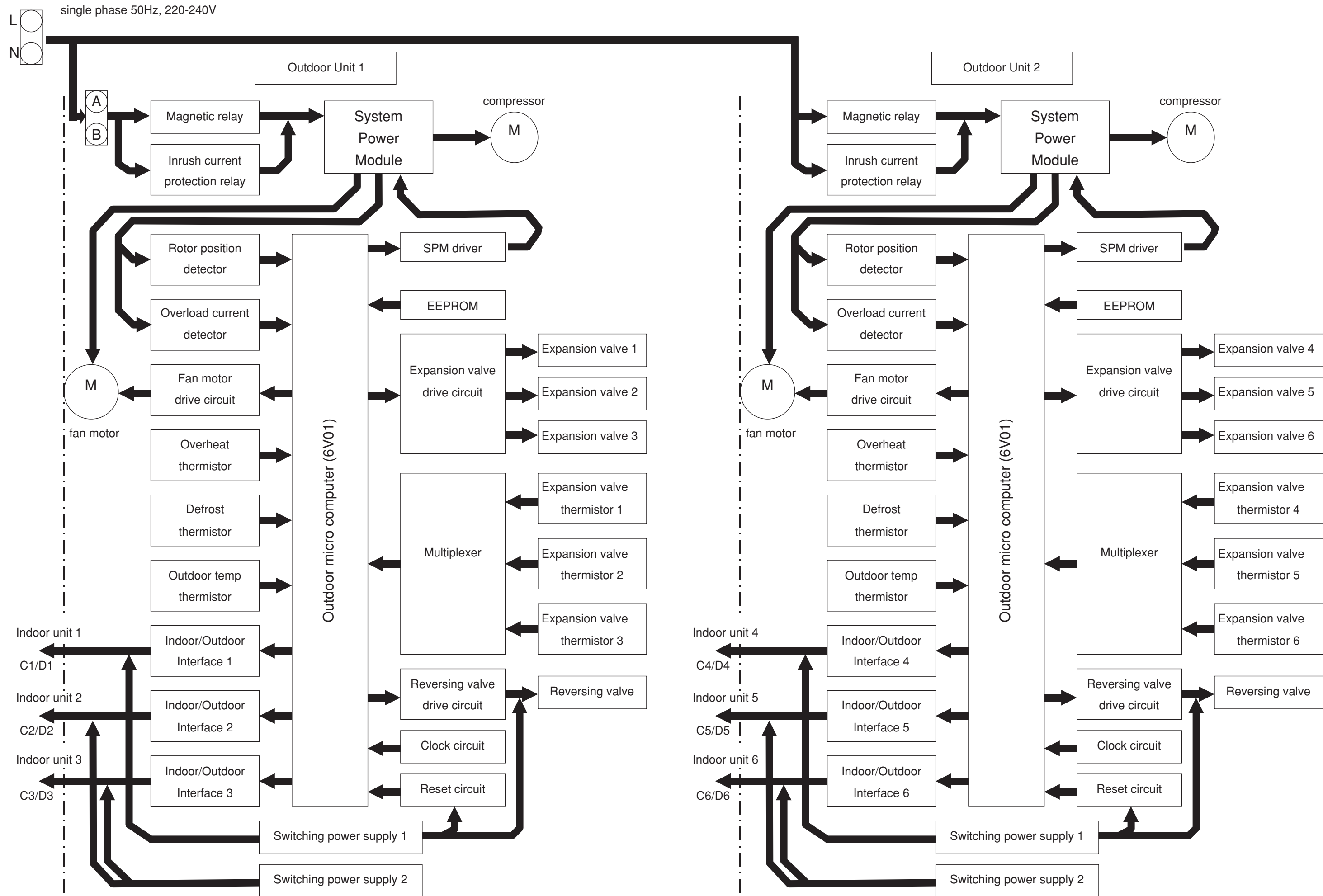

BASIC MODE

Operation mode	Fan	Cooling	Dehumidifying	Heating	Auto							
Basic operation of start / stop switch												
Timer functions	Off-timer											
	On-timer											
Fan speed mode (indoor fan)	Auto	<p>Changes from "Hi" to "Med" or "Lo" depending on room temperature.</p> <p>1. Runs at "Hi" until first thermo off after operation is started. 2. Runs at "Lo" when thermo is off.</p>		<p>Set to "Ultra-Lo", "Lo", "Med", "Hi", "Ultra-Hi" or "stop" depending on the room temperature, time and heat exchange temperature. Set to "stop" if the room temperature is 18°C in the "Ultra-Lo" mode other than during preheating (cooling is recovered at 18.33°C).</p>	<p>Operation mode</p> <ul style="list-style-type: none"> Judgment based on the room temperature and external temperature: <ul style="list-style-type: none"> Cooling: external temperature $\geq 25^{\circ}\text{C}$, or $21^{\circ}\text{C} \leq$ external temperature $< 25^{\circ}\text{C}$ and room temperature $> 27^{\circ}\text{C}$ Heating: external temperature $< 18^{\circ}\text{C}$, or $18^{\circ}\text{C} \leq$ external temperature $< 21^{\circ}\text{C}$ and room temperature $\leq 23^{\circ}\text{C}$ Dehumidifying: $21^{\circ}\text{C} \leq$ external temperature $< 25^{\circ}\text{C}$ and room temperature $\leq 27^{\circ}\text{C}$, or $18^{\circ}\text{C} \leq$ external temperature $< 21^{\circ}\text{C}$ and room temperature $> 23^{\circ}\text{C}$ Set to the mode of the indoor unit that has previously been operating. <p>If, when one indoor unit is heating, the other unit is set to auto, the other unit will also enter the heating operation. If, when one indoor unit is cooling or dehumidifying, the other unit is set to auto, the other unit will enter the cooling or dehumidifying operation.</p>	<p>The special auto mode is based on auto, but the following is different:</p> <table border="1"> <tr> <th>Operation mode</th> <th>Mode change during operation</th> </tr> <tr> <td>auto</td> <td>Judging the operation mode from the external temperature and room temperature at the start.</td> </tr> <tr> <td>Special auto</td> <td>The operation mode will be judged the same as at operation start every hour.</td> </tr> </table> <p>The special auto operation mode is entered when operation is started in the following status:</p> <p><Start condition> Power is supplied while the tele-control signal is being input. (Operation starts automatically.)</p> <p><End condition> The remote control restores the normal operation mode.</p>	Operation mode	Mode change during operation	auto	Judging the operation mode from the external temperature and room temperature at the start.	Special auto	The operation mode will be judged the same as at operation start every hour.
	Operation mode	Mode change during operation										
	auto	Judging the operation mode from the external temperature and room temperature at the start.										
	Special auto	The operation mode will be judged the same as at operation start every hour.										
Hi	Operates at "Hi" regardless of the room temperature.	Set to "Ultra-Hi" when the compressor runs at maximum speed, and to "Hi" in other modes.		Set to "Ultra-Lo", "Lo", "Med", "Hi", "Ultra-Hi" or "Stop" depending on the room temperature and time. Set to "Stop" if the room temperature is 18°C in the "Ultra-Lo" mode other than during preheating (cooling is recovered at 18.33°C). Set to "Ultra-Hi" when the compressor is running at maximum speed during hot dash or when recovered from defrosting.	<p>Temperature (°C)</p> <p>External temperature (°C)</p>							
Med	Operates at "Med" regardless of the room temperature.	Same as at left.		Set to "Ultra-Lo", "Lo", "Med" or "Stop" depending on the room temperature and time. Set to "Stop" if the room temperature is 18°C in the "Ultra-Lo" mode other than during preheating (cooling is recovered at 18.33°C).								
Lo	Operates at "Lo" regardless of the room temperature.	Same as at left.	Set to "Lo" in modes other than when the compressor stops.	Set to "Ultra-Lo", "Lo", or "Stop" depending on the room temperature and time. Set to "Stop" if the room temperature is 18°C in the "Ultra-Lo" mode other than during preheating (cooling is recovered at 18.33°C). The fan speed is controlled by the heat exchanger temperature; the overload control is executed as in the following diagram:								
Basic operation of temperature controller	Performs only fan operation at the set speed regardless of the room temperature.	See page 53.	See page 57.	See page 59.	<p>Set room temperature</p> <ul style="list-style-type: none"> All the following temperatures can be compensated for $\pm 3^{\circ}\text{C}$ using the remote control: <ul style="list-style-type: none"> Cooling: 27°C Heating: 23°C Dehumidifying: Current room temperature (upper limit: 27°C, lower limit: 23°C) Operates at a target of set temperature minus 2°C. 							
Sleep operation (with sleep button ON)	Enters sleep operation after set as on the left. Action during sleep operation silent (sleep) operation	·Same as at left. ·See page 55.	·Same as at left. ·See page 57.	·Same as at left. ·See page 61.	·Same as at left. ·Performs the sleep operation of each operation mode.							

Combination of operations:

When operation mode is selected:

- You cannot operate the indoor units in the following combinations.
- The indoor unit which is switched on first continues to operate, but other indoor units which is switched on later, does not operate while the lamp lights.

One unit	Other unit
Heating	Cooling
	Dehumidifying
	Circulating (fan)

During automatic operation:

- When heating operation is automatically selected for the first indoor unit, the next indoor unit will then start to heat. Also, if cooling or dehumidifying is automatically selected for the first indoor unit, the next indoor unit will also start to cool or dehumidify.

Notes:

- Refer to the PWRITE-ZU data for the constants expressed by capital alphabet letters in the drawing.
- The speed set of rotation for the fan motor in each operation mode are as shown in Table 1.
- The set room temperatures in the diagram include the shift values in Table 2.

PROM NO.	MODEL	RAK-18NH5	RAK-25NH5	RAK-35NH5	RAK-50NH5
	LABEL NAME	REQUIRED VALUE OF UNIT SIDE	REQUIRED VALUE OF UNIT SIDE	REQUIRED VALUE OF UNIT SIDE	REQUIRED VALUE OF UNIT SIDE
0A2	RTOTSA	0 °C	0 °C	2.00 °C	2.00 °C
120	WMAX_M	5300 min ⁻¹	5300 min ⁻¹	5000 min ⁻¹	4500 min ⁻¹
121	WMAX2_M	5300 min ⁻¹	5300 min ⁻¹	5000 min ⁻¹	4500 min ⁻¹
122	WSTD_M	4000 min ⁻¹	4000 min ⁻¹	4000 min ⁻¹	4000 min ⁻¹
123	WJKMAX_M	3700 min ⁻¹	3700 min ⁻¹	3700 min ⁻¹	4000 min ⁻¹
124	WBEMAX_M	3500 min ⁻¹	3500 min ⁻¹	3500 min ⁻¹	3700 min ⁻¹
127	CMAX_M	3300 min ⁻¹	3300 min ⁻¹	3300 min ⁻¹	4000 min ⁻¹
128	CMAX2_M	3300 min ⁻¹	3300 min ⁻¹	3300 min ⁻¹	4000 min ⁻¹
129	CSTD_M	3250 min ⁻¹	3250 min ⁻¹	3150 min ⁻¹	3100 min ⁻¹
12A	CKYMAX_M	2800 min ⁻¹	2800 min ⁻¹	2800 min ⁻¹	2800 min ⁻¹
12B	CJKMAX_M	2750 min ⁻¹	2750 min ⁻¹	2750 min ⁻¹	2750 min ⁻¹
12C	CBEMAX_M	2500 min ⁻¹	2500 min ⁻¹	2500 min ⁻¹	2500 min ⁻¹
12F	SDMAX_M	2400 min ⁻¹	2400 min ⁻¹	1550 min ⁻¹	1800 min ⁻¹
130	SDRPM_M	2100 min ⁻¹	2100 min ⁻¹	1400 min ⁻¹	1100 min ⁻¹
138	WMIN_M	800 min ⁻¹	800 min ⁻¹	800 min ⁻¹	800 min ⁻¹
139	CMINHI_M	800 min ⁻¹	800 min ⁻¹	800 min ⁻¹	800 min ⁻¹
13A	CMIN_M	1200 min ⁻¹	1200 min ⁻¹	1200 min ⁻¹	1200 min ⁻¹
13B	DMIN_M	1200 min ⁻¹	1200 min ⁻¹	1200 min ⁻¹	1200 min ⁻¹
13C	PKOU_M	550 min ⁻¹	550 min ⁻¹	550 min ⁻¹	550 min ⁻¹
13D	FZZY_GN_M	1.5	1.5	1.5	1.5
13E	FZZYTM_M	4 min.	4 min.	4 min.	4 min.
144	SHIFTW_M	2.00 °C	2.00 °C	2.00 °C	2.00 °C
145	SFTSZW_M	2.00 °C	2.00 °C	2.00 °C	2.00 °C
146	SHIFTC_M	1.33 °C	1.33 °C	1.33 °C	1.33 °C
147	SHIFTD_M	3.33 °C	3.33 °C	3.33 °C	3.33 °C
148	CLMXTM_M	30.00 °C	30.00 °C	30.00 °C	30.00 °C
149	YNEOF_M	25.00 °C	25.00 °C	25.00 °C	20.00 °C
14E	TEION_M	2.00 °C	2.00 °C	2.00 °C	2.00 °C
14F	TEIOF_M	9.00 °C	9.00 °C	9.00 °C	9.00 °C
157	CMNLMT_M	0 min ⁻¹	0 min ⁻¹	0 min ⁻¹	1950 min ⁻¹
178	FWSS_M	500 min ⁻¹	500 min ⁻¹	500 min ⁻¹	450 min ⁻¹
179	FWSOY_M	600 min ⁻¹	600 min ⁻¹	700 min ⁻¹	760 min ⁻¹
17A	FWS_M	720 min ⁻¹	750 min ⁻¹	820 min ⁻¹	850 min ⁻¹
17B	FWKAF_M	840 min ⁻¹	850 min ⁻¹	920 min ⁻¹	1000 min ⁻¹
17C	FWL_M	840 min ⁻¹	850 min ⁻¹	920 min ⁻¹	1130 min ⁻¹
17D	FWAH_M	940 min ⁻¹	1050 min ⁻¹	1120 min ⁻¹	1270 min ⁻¹
17E	FWH_M	940 min ⁻¹	1050 min ⁻¹	1120 min ⁻¹	1330 min ⁻¹
17F	FWHH_M	1030 min ⁻¹	1170 min ⁻¹	1250 min ⁻¹	1330 min ⁻¹
180	FCSOY_M	550 min ⁻¹	600 min ⁻¹	680 min ⁻¹	700 min ⁻¹
181	FCS_M	650 min ⁻¹	750 min ⁻¹	780 min ⁻¹	800 min ⁻¹
182	FCL_M	740 min ⁻¹	870 min ⁻¹	950 min ⁻¹	1040 min ⁻¹
183	FCAH_M	850 min ⁻¹	980 min ⁻¹	1030 min ⁻¹	1410 min ⁻¹
184	FCH_M	890 min ⁻¹	1030 min ⁻¹	1170 min ⁻¹	1410 min ⁻¹
185	FCHH_M	990 min ⁻¹	1030 min ⁻¹	1200 min ⁻¹	1410 min ⁻¹
186	FDOY_M	600 min ⁻¹	600 min ⁻¹	680 min ⁻¹	700 min ⁻¹
187	FDS1_M	720 min ⁻¹	750 min ⁻¹	780 min ⁻¹	800 min ⁻¹
188	FDS2_M	720 min ⁻¹	750 min ⁻¹	780 min ⁻¹	800 min ⁻¹

Table 1 Fan speed by mode

Operation mode	Fan speed mode		Label name
Heating operation	Ultra Lo		FWSS_M
	Sleep		FWSOY_M
	Lo		FWS_M
	Overload		FWKAF_M
	Med		FWL_M
	Hi	Set fan speed "AUTO"	FWAH_M
	Hi	Set fan speed "HI"	FWH_M
	Ultra Hi		FWHH_M
Cooling operation	Sleep		FCSOY_M
	Lo		FCS_M
	Med		FCL_M
	Hi	Set fan speed "AUTO"	FCAH_M
	Hi	Set fan speed "HI"	FCH_M
	Ultra Hi		FCHH_M
Dehumidifying operation	Sleep		FDOY_M
	Lo 1		FDS1_M
	Lo 2		FDS2_M

Table 2 Room temperature shift value

Operation mode	Fan speed	Label name
Heating operation	Fan speed "AUTO, Hi, Med"	SHIFTW_M
	Fan speed "Lo, Sleep"	SFTSZW_M
Cooling operation		SHIFTC_M
Dehumidifying operation		SHIFTD_M

N O .	MODEL	RAF-25NH5	RAF-35NH5	RAF-50NH5
	LABEL NAME	REQUIRED VALUE OF UNIT SIDE	REQUIRED VALUE OF UNIT SIDE	REQUIRED VALUE OF UNIT SIDE
09C	RTOTSA	2.00 °C	2.00 °C	2.00 °C
120	WMAX_M	5300 min ⁻¹	5000 min ⁻¹	4500 min ⁻¹
121	WMAX2_M	5300 min ⁻¹	5000 min ⁻¹	4500 min ⁻¹
122	WSTD_M	4000 min ⁻¹	4000 min ⁻¹	4000 min ⁻¹
123	WJMAX_M	3700 min ⁻¹	3700 min ⁻¹	4000 min ⁻¹
124	WBEMAX_M	3500 min ⁻¹	3500 min ⁻¹	3700 min ⁻¹
125	CMAX_M	3500 min ⁻¹	3300 min ⁻¹	4000 min ⁻¹
126	CMAX2_M	3500 min ⁻¹	3300 min ⁻¹	4000 min ⁻¹
127	CSTD_M	3250 min ⁻¹	3150 min ⁻¹	3100 min ⁻¹
128	CKYMAX_M	2800 min ⁻¹	2800 min ⁻¹	2800 min ⁻¹
129	CJKMAX_M	2750 min ⁻¹	2750 min ⁻¹	2750 min ⁻¹
12A	CBEMAX_M	2500 min ⁻¹	2500 min ⁻¹	2500 min ⁻¹
12B	SDMAX_M	2400 min ⁻¹	2400 min ⁻¹	1800 min ⁻¹
12C	SDRPM_M	2000 min ⁻¹	2000 min ⁻¹	1100 min ⁻¹
132	WMIN_M	800 min ⁻¹	800 min ⁻¹	800 min ⁻¹
133	CMINHI_M	800 min ⁻¹	800 min ⁻¹	800 min ⁻¹
134	CMIN_M	1200 min ⁻¹	1200 min ⁻¹	1200 min ⁻¹
135	DMIN_M	1200 min ⁻¹	1200 min ⁻¹	1100 min ⁻¹
136	PKOU_M	500 min ⁻¹	500 min ⁻¹	500 min ⁻¹
137	FZZY_GN_M	1.0	1.0	1.0
138	FZZYTM_M	3 min.	3 min.	3 min.
13E	SHIFTW_M	2.33 °C	2.33 °C	2.33 °C
13F	SFTSZW_M	0.66 °C	0.66 °C	0.66 °C
140	SHIFTO_M	-0.66 °C	-0.66 °C	-0.66 °C
141	SHIFTD_M	-0.66 °C	-0.66 °C	-0.66 °C
142	CLMXTP_M	30.00 °C	30.00 °C	30.00 °C
143	YNEOF_M	23.00 °C	23.00 °C	23.00 °C
148	TEION_M	2.00 °C	2.00 °C	2.00 °C
149	TEIOF_M	9.00 °C	9.00 °C	9.00 °C
150	CMNLMT_M	1900 min ⁻¹	1900 min ⁻¹	1900 min ⁻¹
16D	FWSS_M	400 min ⁻¹	400 min ⁻¹	400 min ⁻¹
16E	FWSOY_M	710 min ⁻¹	720 min ⁻¹	740 min ⁻¹
16F	FWS_M	710 min ⁻¹	800 min ⁻¹	820 min ⁻¹
170	FWKAF_M	790 min ⁻¹	880 min ⁻¹	950 min ⁻¹
171	FWL_M	790 min ⁻¹	880 min ⁻¹	950 min ⁻¹
172	FWAH_M	830 min ⁻¹	960 min ⁻¹	1040 min ⁻¹
173	FWH_M	870 min ⁻¹	1000 min ⁻¹	1080 min ⁻¹
174	FWHM_M	960 min ⁻¹	1050 min ⁻¹	1100 min ⁻¹
175	FWHH_M	960 min ⁻¹	1050 min ⁻¹	1110 min ⁻¹
176	FCSOY_M	670 min ⁻¹	670 min ⁻¹	670 min ⁻¹
177	FCS_M	670 min ⁻¹	770 min ⁻¹	730 min ⁻¹
178	FCL_M	750 min ⁻¹	860 min ⁻¹	920 min ⁻¹
179	FCAH_M	790 min ⁻¹	950 min ⁻¹	1000 min ⁻¹
17A	FCH_M	830 min ⁻¹	1000 min ⁻¹	1050 min ⁻¹
17B	FCHM_M	880 min ⁻¹	1040 min ⁻¹	1090 min ⁻¹
17C	FCHH_M	880 min ⁻¹	1040 min ⁻¹	1090 min ⁻¹
17D	FDOY_M	670 min ⁻¹	700 min ⁻¹	730 min ⁻¹
17E	FDS1_M	670 min ⁻¹	700 min ⁻¹	730 min ⁻¹
17F	FDS2_M	670 min ⁻¹	700 min ⁻¹	730 min ⁻¹
180	FCLN_M	600 min ⁻¹	600 min ⁻¹	600 min ⁻¹
186	FWOPN_M	1060 min ⁻¹	960 min ⁻¹	1250 min ⁻¹
187	FCOPN_M	1020 min ⁻¹	880 min ⁻¹	1090 min ⁻¹
188	FWCLD_M	1060 min ⁻¹	960 min ⁻¹	1250 min ⁻¹
189	FCCLD_M	1020 min ⁻¹	880 min ⁻¹	1090 min ⁻¹
18A	FWUDSS_M	400 min ⁻¹	400 min ⁻¹	400 min ⁻¹
18B	FWUDSOY_M	640 min ⁻¹	640 min ⁻¹	660 min ⁻¹
18C	FWUDS_M	640 min ⁻¹	720 min ⁻¹	740 min ⁻¹
18D	FWUDKAF_M	710 min ⁻¹	780 min ⁻¹	860 min ⁻¹
18E	FWUDL_M	710 min ⁻¹	780 min ⁻¹	860 min ⁻¹
18F	FWUDAH_M	750 min ⁻¹	880 min ⁻¹	950 min ⁻¹
190	FWUDH_M	780 min ⁻¹	900 min ⁻¹	970 min ⁻¹
191	FWUDHH_M	870 min ⁻¹	950 min ⁻¹	990 min ⁻¹
192	FCUDSOY_M	600 min ⁻¹	630 min ⁻¹	660 min ⁻¹
193	FCUDS_M	600 min ⁻¹	630 min ⁻¹	660 min ⁻¹
194	FCUDL_M	680 min ⁻¹	780 min ⁻¹	820 min ⁻¹
195	FCUDAH_M	710 min ⁻¹	860 min ⁻¹	900 min ⁻¹
196	FCUDH_M	750 min ⁻¹	900 min ⁻¹	940 min ⁻¹
197	FCUDHH_M	790 min ⁻¹	940 min ⁻¹	980 min ⁻¹
19D	FWUDOPN_M	950 min ⁻¹	870 min ⁻¹	1100 min ⁻¹
19E	FCUDOPN_M	900 min ⁻¹	790 min ⁻¹	980 min ⁻¹

Table 1 Fan speed by mode

Operation mode	Fan speed mode		Label name	
Heating operation	Upper Fan	Ultra Lo	FWSS_M	
		Sleep	FWSOY_M	
		Lo	FWS_M	
		Overload	FWKAF_M	
		Med	FWL_M	
		Hi	Set fan speed "HI"	FWH_M
		Ultra Hi	(When AIR OUTLET SWITCH "ON")	FWHM_M
	Lower Fan	Ultra Hi	(When AIR OUTLET SWITCH "OFF")	FWHM_M
		Hi	Set fan speed "AUTO"	FWAH_M
		Ultra Lo		FWUDSS_M
		Sleep		FWUDSOY_M
		Lo		FWUDS_M
		Overload		FWUDKAF_M
		Med		FWUDL_M
Cooling operation	Upper Fan	Hi	Set fan speed "HI"	FWUDH_M
		Ultra Hi	(When AIR OUTLET SWITCH "ON")	FWUDHH_M
		Ultra Hi	(When AIR OUTLET SWITCH "OFF")	FWUDHH_M
	Lower Fan	Hi	Set fan speed "AUTO"	FWUDAH_M
		Sleep		FCSOY_M
		Lo		FCS_M
Dehumidifying operation	Upper Fan	Med		FCL_M
		Hi	Set fan speed "HI"	FCH_M
		Ultra Hi	(When AIR OUTLET SWITCH "ON")	FCHM_M
	Lower Fan	Ultra Hi	(When AIR OUTLET SWITCH "OFF")	FCHH_M
		Hi	Set fan speed "AUTO"	FCAH_M
		Sleep		FCUDSOY_M
Dehumidifying operation	Lower Fan	Lo		FCUDS_M
		Med		FCUDL_M
		Hi	Set fan speed "HI"	FCUDH_M
Dehumidifying operation	Lower Fan	Ultra Hi	Set fan speed "HI"	FCUDHH_M
		Hi	Set fan speed "AUTO"	FCUDAH_M
		Sleep		FDOY_M
Dehumidifying operation	Lower Fan	Lo1		FDS1_M
		Lo2		FDS2_M

Table 2 Room temperature shift value

Operation mode	Fan speed "AUTO, Hi, Med"	Shift value
Heating operation	Fan speed "AUTO, Hi, Med"	SHIFTW
Cooling operation	Fan speed "Lo, Sleep"	SFTSZW
Dehumidifying operation		SHIFTC
		SHIFTD

PROM NO.	MODEL	RAD-25NH5	RAD-35NH5
	LABEL NAME	REQUIRED VALUE OF UNIT SIDE	REQUIRED VALUE OF UNIT SIDE
0A2	RTOTSA	2.00 °C	2.00 °C
120	WMAX_M	5300 min ⁻¹	5000 min ⁻¹
121	WMAX2_M	5300 min ⁻¹	5000 min ⁻¹
122	WSTD_M	4000 min ⁻¹	4000 min ⁻¹
123	WJKMAX_M	3600 min ⁻¹	3700 min ⁻¹
124	WBEMAX_M	3200 min ⁻¹	3500 min ⁻¹
127	CMAX_M	3300 min ⁻¹	3300 min ⁻¹
128	CMAX2_M	3300 min ⁻¹	3300 min ⁻¹
129	CSTD_M	3000 min ⁻¹	3150 min ⁻¹
12A	CKYMAX_M	2500 min ⁻¹	2800 min ⁻¹
12B	CJKMAX_M	2300 min ⁻¹	2750 min ⁻¹
12C	CBEMAX_M	1900 min ⁻¹	2500 min ⁻¹
12F	SDMAX_M	2050 min ⁻¹	2400 min ⁻¹
130	SDRPM_M	1800 min ⁻¹	2000 min ⁻¹
138	WMIN_M	800 min ⁻¹	800 min ⁻¹
139	CMINHI_M	800 min ⁻¹	800 min ⁻¹
13A	CMIN_M	1000 min ⁻¹	1200 min ⁻¹
13B	DMIN_M	1000 min ⁻¹	1200 min ⁻¹
13C	PKOU_M	500 min ⁻¹	500 min ⁻¹
13D	FZZY_GN_M	1.0	1.0
13E	FZZYTM_M	3 min.	3 min.
144	SHIFTW_M	5.00 °C	5.00 °C
145	SFTSZW_M	5.00 °C	5.00 °C
146	SHIFTC_M	1.66 °C	1.66 °C
147	SHIFTD_M	1.66 °C	1.66 °C
148	CLMXTM_M	30.00 °C	30.00 °C
149	YNEOF_M	20.00 °C	20.00 °C
14E	TEION_M	0.00 °C	0.00 °C
14F	TEIOF_M	9.00 °C	9.00 °C
157	CMNLMT_M	0 min ⁻¹	0 min ⁻¹
178	FWSS_M	13.1 V	13.1 V
179	FWSOY_M	17.6 V	17.6 V
17A	FWS_M	20.3 V	20.3 V
17B	FWKAF_M	22.9 V	22.9 V
17C	FWL_M	22.9 V	22.9 V
17D	FWAH_M	27.9 V	27.9 V
17E	FWH_M	28.3 V	28.3 V
17F	FWHH_M	28.3 V	28.3 V
180	FCSOY_M	18.0 V	18.0 V
181	FCS_M	20.5 V	20.5 V
182	FCL_M	25.0 V	25.0 V
183	FCAH_M	27.9 V	27.9 V
184	FCH_M	27.9 V	27.9 V
185	FCHH_M	27.9 V	27.9 V
186	FDOY_M	18.0 V	18.0 V
187	FDS1_M	20.5 V	20.5 V
188	FDS2_M	20.5 V	20.5 V

Table 1 Fan speed by mode

Operation mode	Fan speed mode		Label name
Heating operation	Ultra Lo		FWSS_M
	Sleep		FWSOY_M
	Lo		FWS_M
	Overload		FWKAF_M
	Med		FWL_M
	Hi	Set fan speed "AUTO"	FWAH_M
	Hi	Set fan speed "HI"	FWH_M
	Ultra Hi		FWHH_M
Cooling operation	Sleep		FCSOY_M
	Lo		FCS_M
	Med		FCL_M
	Hi	Set fan speed "AUTO"	FCAH_M
	Hi	Set fan speed "HI"	FCH_M
	Ultra Hi		FCHH_M
Dehumidifying operation	Sleep		FDOY_M
	Lo 1		FDS1_M
	Lo 2		FDS2_M

Table 2 Room temperature shift value

Operation mode	Fan speed	Label name
Heating operation	Fan speed "AUTO, Hi, Med"	SHIFTW_M
	Fan speed "Lo, Sleep"	SFTSZW_M
Cooling operation		SHIFTC_M
Dehumidifying operation		SHIFTD_M

MODEL		RAM-130QH5	
PROM NO.	LABEL NAME	REQUIRED VALUE OF UNIT SIDE	
03A	PSTARTC1\$	250	pulse
03B	PSTARTC1K\$	300	pulse
03C	PSTARTC2\$	150	pulse
03D	PSTARTC2K\$	300	pulse
03E	PSTARTC3\$	150	pulse
03F	PSTARTC3K\$	300	pulse
040	PSTARTH1\$	200	pulse
041	PSTARTH1S\$	250	pulse
042	PSTARTH2\$	100	pulse
043	PSTARTH2S\$	150	pulse
044	PSTARTH3\$	250	pulse
045	PSTARTH3S\$	250	pulse
046	PMIN\$	30	pulse
047	DFCTPS\$	100	pulse
048	DFCTPN\$	240	pulse
049	DFSPPS\$	44	pulse
04A	DFPSMX\$	480	pulse
04B	PCLOSH\$	60	pulse
0FD	CMAX1	5400	min ⁻¹
0FE	CMAX2	6100	min ⁻¹
101	CMAX3	6200	min ⁻¹
104	CMAX4	6300	min ⁻¹
108	WMAX1	6200	min ⁻¹
109	WMAX2	6200	min ⁻¹
10C	WMAX3	6200	min ⁻¹
10F	WMAX4	6300	min ⁻¹
11E	STAROTP_C	25.0	°C
11F	SDRCT1_C1	2000	min ⁻¹
120	TSKTM1_C1	40	sec
121	SDRCT1_C2	3000	min ⁻¹
122	TSKTM_C2	60	sec
123	STAROTP_W	4.8	°C
124	SDRCT1_W1	2000	min ⁻¹
125	TSKTM1_W1	60	sec
126	SDRCT1_W2	3000	min ⁻¹
127	TSKTM1_W2	60	sec
128	SDSTEP	1000	min ⁻¹
129	TSKSPT	8	sec
12A	KYO_RPM	3000	min ⁻¹
198	TDF414	90	sec
199	DFMXTM	12	min ⁻¹
19A	SDRCT2	2000	min ⁻¹
19B	TSKTM2	60	sec
19C	DFSTEP	600	min ⁻¹
19D	TDFSPT	60	sec
19E	DEFMAX	6000	min ⁻¹
19F	TDF415	120	sec
1A0	DFSTMB	55	min.
1A1	DFSTMB2	60	min.
1A2	DEFONH	-1.9	°C
1A3	DEFON	-5.1	°C
1A4	DEFONL	-23.9	°C
1A5	DEF_a1	112/128	
1A6	DEF_a2	138/128	
1A7	DEFOFF	15.0	°C

Basic Cooling Operation

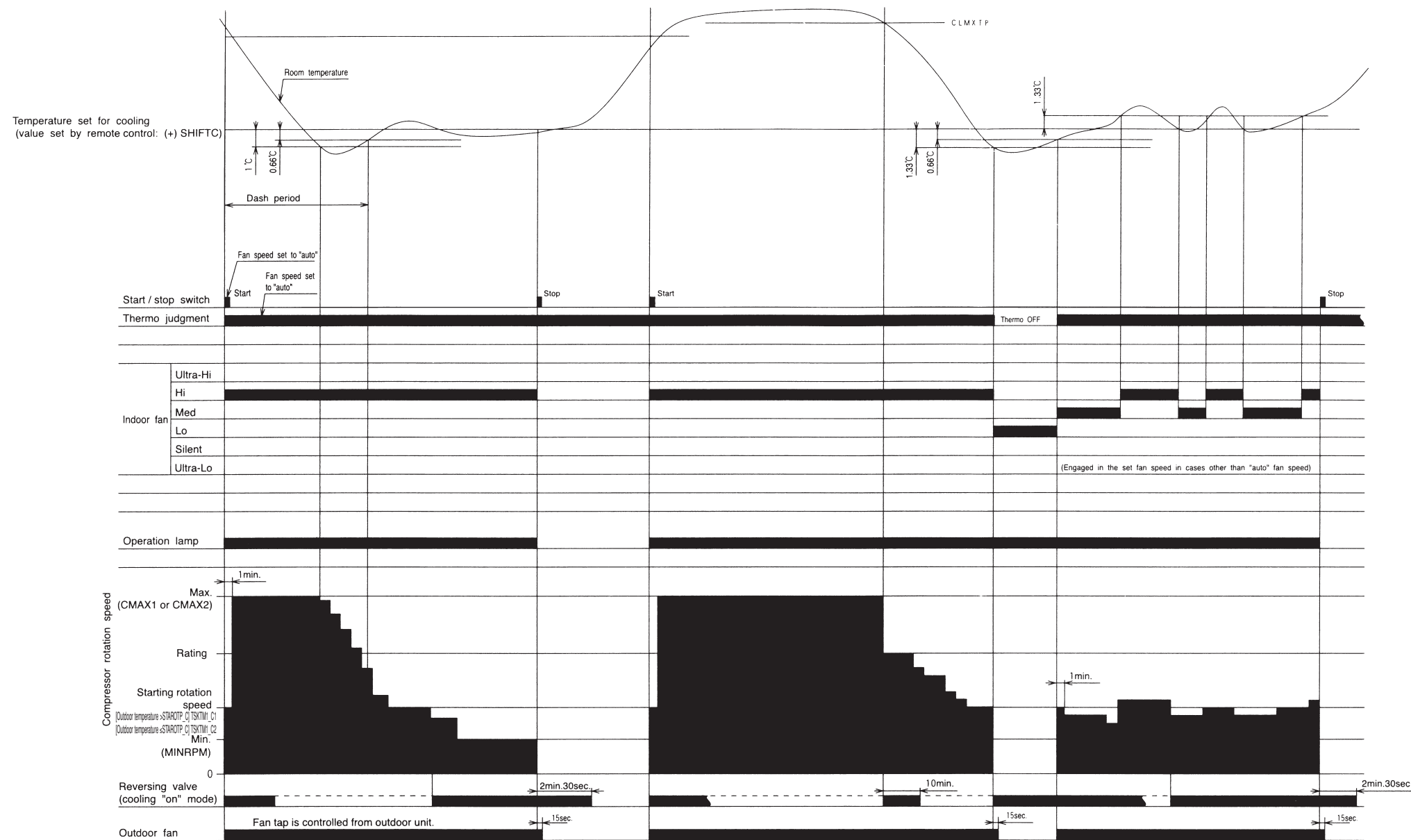

Notes:

- (1) Cool dash is started when the operation is started at fan speed "AUTO" or "HI" or when the fan speed is changed to "AUTO" or "HI" during cooling operation, and when the compressor speed (P item) reaches (Cmax1 or Cmax2) or higher.
- (2) The maximum compressor speed period during cool dash is finished ① when 25 minutes have elapsed after cool dash was started ② when the room temperature reaches the cooling set temperature -1°C (including cooling shift) and then becomes lower than the preset temperature by 0.66°C after the steady speed period, ③ when thermo is OFF.
(If cool dash finished in the above ①, the compressor does not go through the steady speed period but it starts fuzzy control.)
- (3) The thermo OFF temperature during cool dash is cooling set temperature (including cooling shift) -3°C. After thermo OFF, cool dash is finished and fuzzy control starts.
- (4) The compressor minimum ON time and minimum OFF time is 3 minutes.
- (5) The time limit for which the maximum compressor speed (Cmax1 or Cmax2) during normal cooling can be maintained is less than 60 minutes when the room temperature is less than CLMXTP: it is not provided when the room temperature is CLMXTP or more.
- (6) Compressor speed is determined by instruction sent from indoor unit and corrected by outdoor unit according to such factors as capacity, fan speed, number of units being operated, outdoor temperature, etc.
- (7) If another indoor unit is doing heating operation, cooling operation cannot be done.

Cooling Sleep Operation

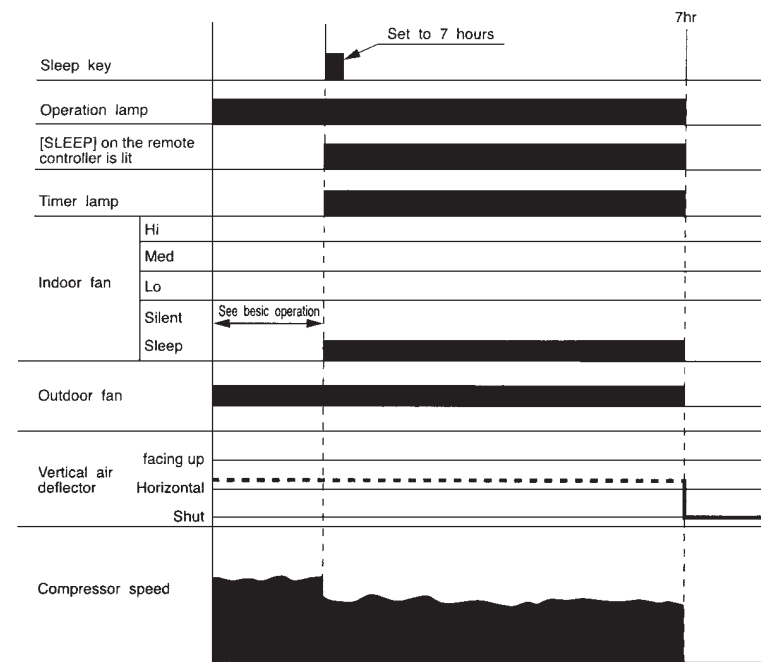

Notes:

- (1) The sleep operation starts when the sleep key is pressed.
- (2) When the sleep key is set, the indoor fan is set to "sleep silent" (FCSOY_M or AFCSOY).
- (3) The indoor fan speed does not change even when the fan speed mode is changed.
- (4) If the set time is changed during sleep operation, all data including set temperature, time, etc. is cleared and restarted.
- (5) If sleep operation is canceled by the cancel key or sleep key, all data is cleared.
- (6) If the position of air deflector is being operated using remote control, the operation will be performed at any desired position of air deflector.

Note:

1. Refer to the PWRITE-ZU data for the constants expressed by capital alphabet letters in the drawing.

Cooling Defrost

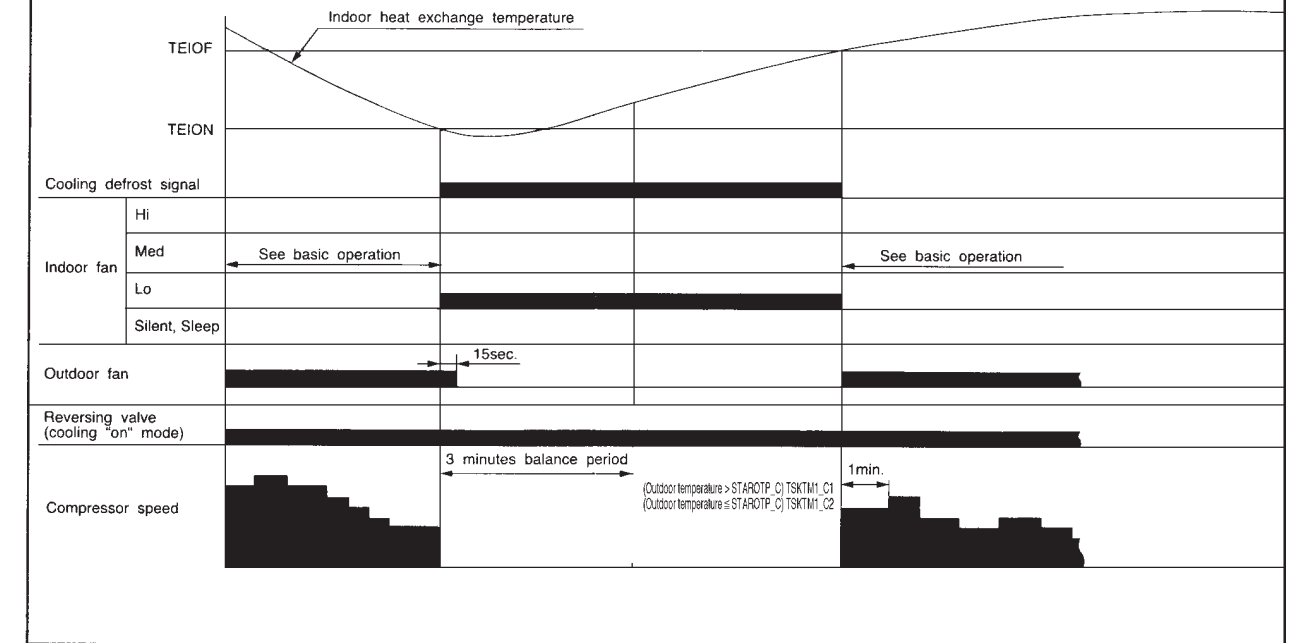

Dehumidifying

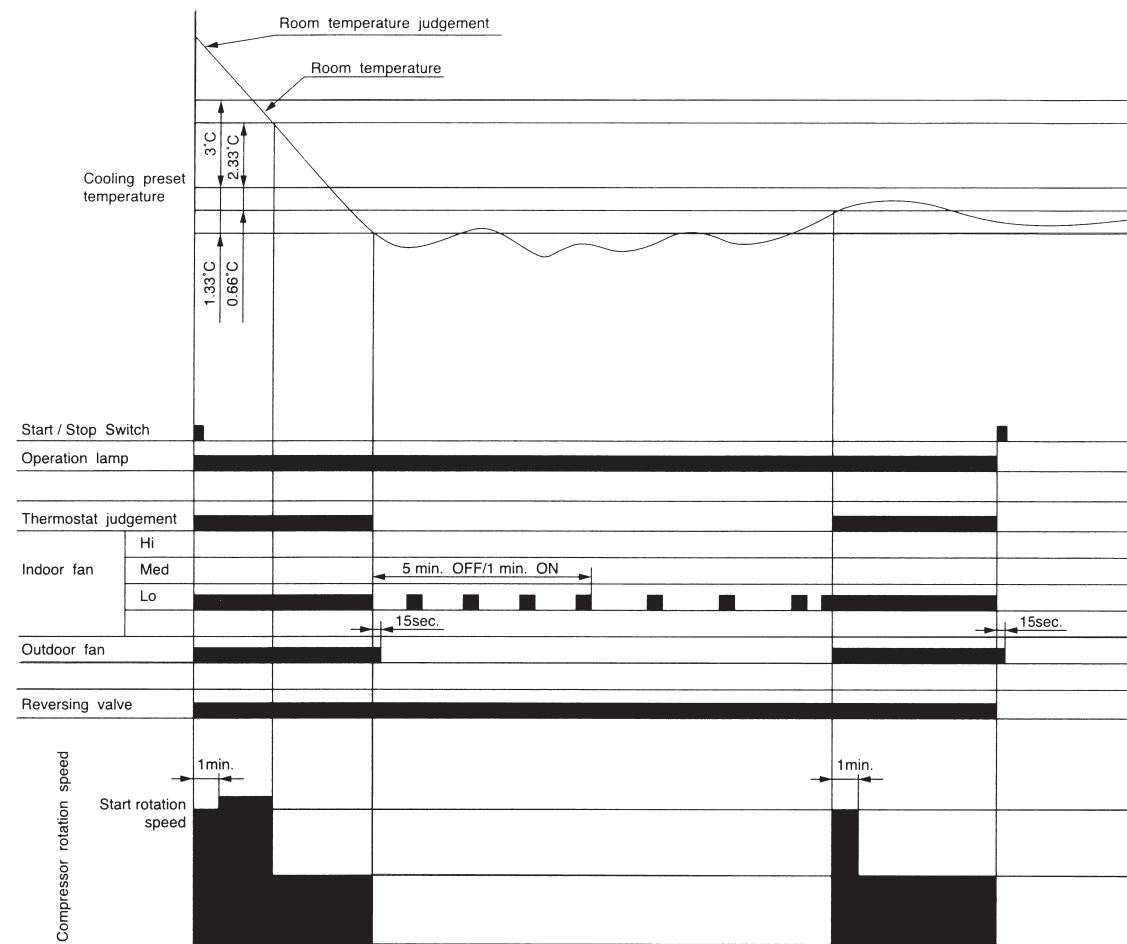

Notes:

- (1) The indoor fan is operated in the "Lo" mode, OFF for 5 minutes and ON for 1 minute, repeatedly according to the humidity judgement when the thermostat is turned OFF.
- (2) The compressor is operated forcedly for 3 minutes after operation is started.
- (3) The minimum ON time and OFF time of the compressor are 3 minutes.
- (4) At the start of operation, the thermostat will be off when room temperature \leq setting temperature -1.33°C ; the thermostat will be on when room temperature \geq setting temperature -0.66°C .
- (5) The following procedure is performed to prevent excessive cooling during operation other than start. However, this procedure applies only when the thermostat is intermittent:
 - Whether THERMO ON is to continue or not depends on the thermal condition when the 3-minute forced operation ceases.
 - ① "THERMO ON continues" when room temperature \geq setting temperature $+1^{\circ}\text{C}$: (The THERMO operation value is usually the same as that at "start of operation")
 - ② "Forced THERMO OFF" when room temperature $<$ setting temperature $+1^{\circ}\text{C}$: (The same THERMO operation value as that at "start of operation" is usually used for recovery)
 Therefore, if the air-conditioner is stabilized under this thermal condition, it will enter intermittent operation, which is "3-minute operation/3-minute stop".
- (6) Compressor speed is determined by instruction sent from indoor unit and corrected by outdoor unit according to such factors as capacity, fan speed, number of units being operated, outdoor temperature, etc.

Dehumidifying Sleep Operation

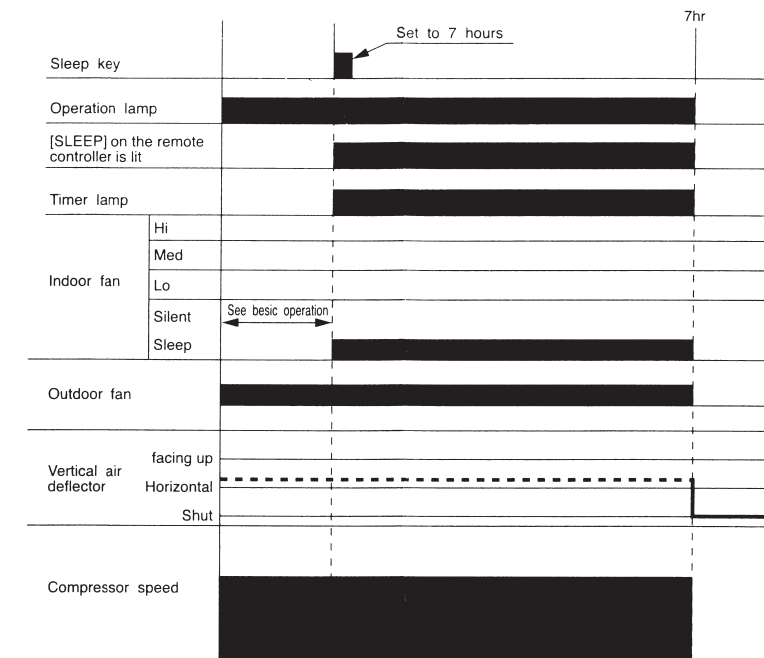

Notes:

- (1) The sleep operation starts when the sleep key is pressed.
- (2) When the sleep key is set, the indoor fan is set to "sleep silent" (FDOY_M or AFDOY).
- (3) The indoor fan speed does not change even when the fan speed mode is changed.
- (4) If the set time is changed during sleep operation, all data including set temperature, time, etc. is cleared and restarted.
- (5) If sleep operation is canceled by the cancel key or sleep key, all data is cleared.
- (6) If the position of air deflector is being operated using remote control, the operation will be performed at any desired position of air deflector.

Heating Basic Operation

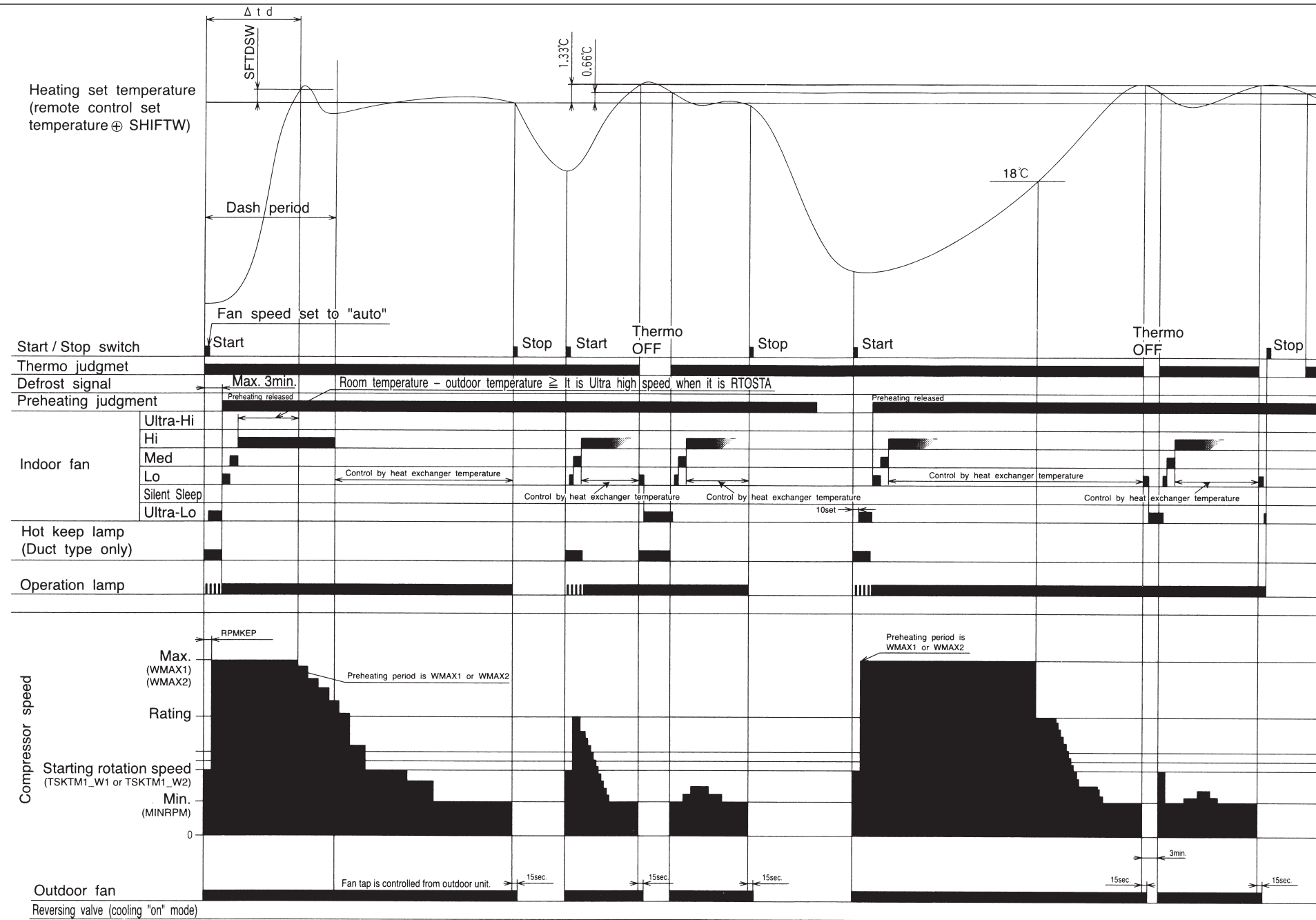

Notes:

- (1) Hot Dash is started when the operation is started at fan speed "AUTO" or "HI" or when the fan speed is changed to "AUTO" or "HI" during heating operation, and when the compressor speed (P item) reaches (WMAX1 or WMAX2) or higher with the room temperature at 8°C or less and outdoor temperature at 10°C or less.
- (2) The maximum compressor speed period during hot dash is finished (1) when the room temperature reaches the heating set temperature (including heating shift) plus SFTDSW or (2) when the thermo is off.
- (3) The thermo OFF temperature during hot dash is heating set temperature (including heating shift) plus 3°C. After thermo OFF, hot dash finishes, and PI control starts.
- (4) The compressor minimum ON time and minimum OFF time is 3 minutes.
- (5) The time limit for which the maximum compressor speed (WMAX1 or WMAX2) during normal heating (except for hot dash) can be maintained is less than 120 minutes when the room temperature is 18°C or more; it is not provided when the room temperature is less than 18°C and outdoor temperature is less than 4°C.
- (6) The operation indicator will blink every second during initial cycle operation, preheating, defrosting (including balance time after defrost is finished), or auto fresh defrosting. However, with duct type models, operation indicator does not blink, but Hot Keep indicator will light. And Hot Keep indicator will also light in "Thermo OFF" mode.
- (7) For preheating judgment, preheating starts if the heat exchange temperature is lower than YNEOFC and is cancelled if the heat exchange temperature is YNEOFC plus 0.33°C or higher at the start of operation using the START/STOP button.
- (8) If the room temperature falls to less than 18°C in the "Ultra-Lo" mode, the indoor fan stops. When the room temperature is 18°C+0.33°C or more, the ultra-Lo operation restarts. However, the ultra-Lo operation during preheating or preheating after defrosting does not stop if the room temperature is less than 18°C.
- (9) Compressor speed is determined by instruction sent from indoor unit and corrected by outdoor unit according to such factors as capacity, fan speed, number of units being operated, outdoor temperature, etc.
- (10) If another indoor unit is doing cooling operation, dehumidifying operation or fan operation, heating operation cannot be done.

Heating Sleep Operation

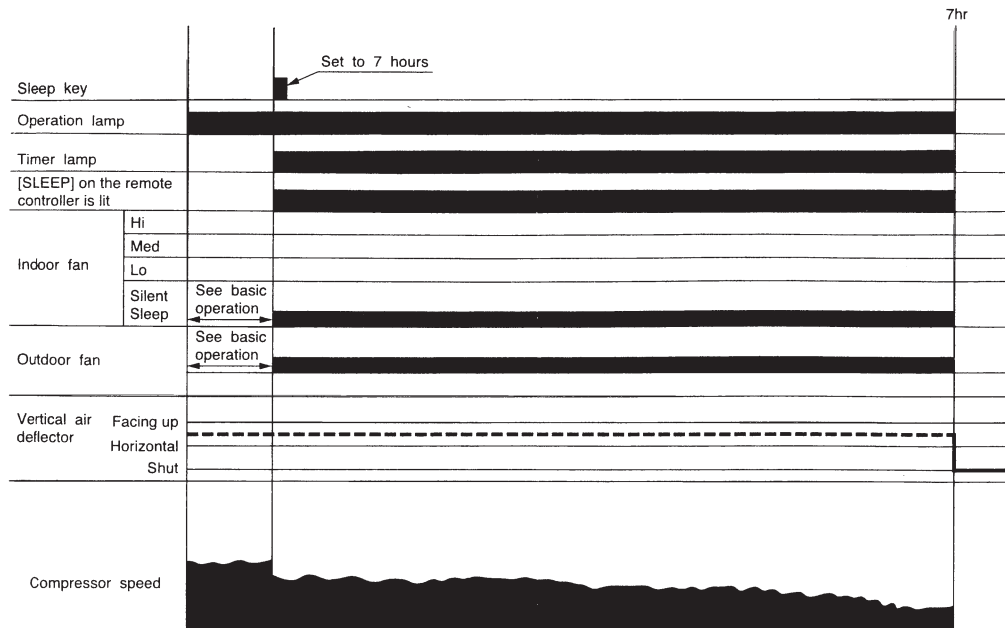

Notes:

- (1) The sleep operation starts when the sleep key is pressed.
- (2) When the sleep key is set, the indoor fan is set to "Sleep Silent" (FWSOY_M or AFWSOY).
- (3) The indoor fan speed does not change even when the fan speed mode is changed.
- (4) When defrosting is to be set during sleep operation, defrosting is engaged and sleep operation is restored after defrosting.
- (5) If the set time is changed during sleep operation, all data including set temperature, time, etc. is cleared and restarted.
- (6) If sleep operation is canceled by the cancel key or sleep key all data is cleared.
- (7) If the position of air deflector is being operated using remote control, the operation will be performed at any desired position of air deflector.

NOTE:

1. Refer to the PWRITE-ZU data for the constants expressed by capital alphabet letters in the drawing.

MODEL RAM-130QH5

◇ Expansion valves

- The expansion valves are initialized when power is supplied. The valve for unit 1 is fully closed (-520 pulses), and then that for unit 2 is fully opened (480 pulses). The valve for unit 2 is fully closed (-520 pulses), and then that for unit 3 is fully opened (480 pulses). When the valve for unit 1, 2, 3 is fully closed (0 pulse), start-up is possible.
- The start openings are held during the steady speed period when the compressor is started. After the steady speed period is finished, the TD control is entered. The start openings are set to PSTARTH when the outdoor temperature at start 40°C or more, and to PSTART when it is less than 40°C.
- This unit contain 2 separated refrigerant cycle. The explanation on expansion Valve for unit 1, 2 and 3 is for one refrigerant cycle, which is the Upper Side of the unit. And for the second refrigerant cycle which is the lower side of the unit, the explanation of expansion valve for unit 4, 5 and 6 shall be the same as unit 1, 2, and 3
- Also, this 2 refrigerant cycles are controlled by totally separated electrical assembly with 2 separated micon.

◇ Compressor rotation speed

- When the compressor is started, the SDRCT1 speed / TSTKTM1 second is held.
After the steady speed period is finished, the speed increases at the rate of SDSTEP speed / TSKSPT second until the target speed is resched.

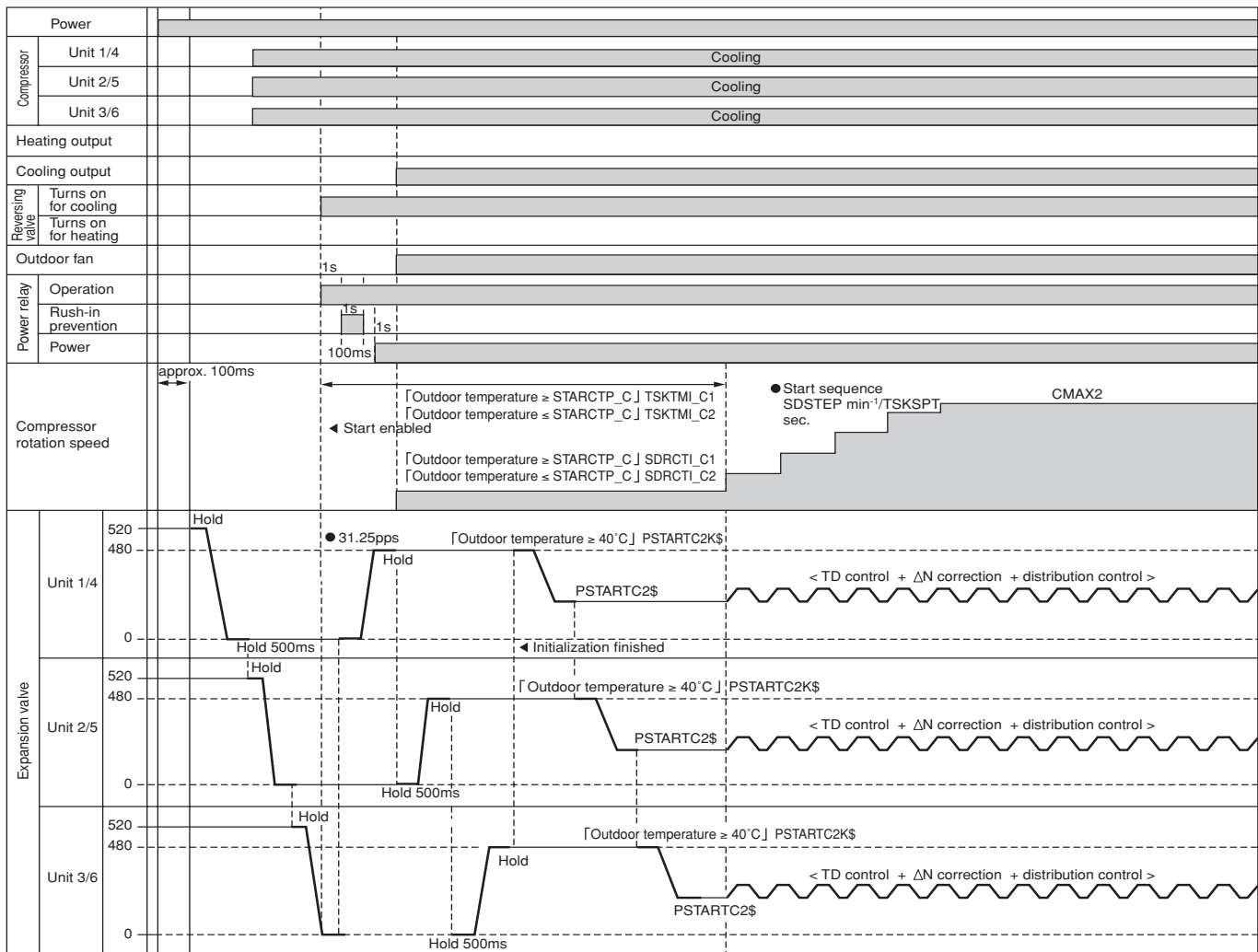

※ TSKTM1, SDRCT1, SDSTEP, TSKSPT, CMAX2, PSTART and PSTARTH are EEPROM data.

DEFROST

• Reversing valve defrost system is employed: it consists of balancing period → reversing cycle period → balancing period.

(1) Defrost start condition

• When all the following conditions are established defrost is executed:

- ① Normal operation
- ② Heat exchange temperature is within defrost range specified by outdoor temperature and heat exchange temperature.
- ③ Defrost inhibit period linked to outdoor temperature has passed.

(2) Defrost release condition

• If any one of the following conditions is established, defrost is released:

- ① Heat exchange temperature returns (heat exchange temperature \geq DEFOFF).
- ② Defrost max time of 12 minutes has elapsed.

• Released by condition ① during balancing period: When remaining balancing period has elapsed, returned to initial condition (ASTUS=0).

• Released by condition ① or ② during reversing cycle period: [TDF415] Shifted to balancing period.

(3) Outputs during defrost

• Indoor defrost request: Transmitted to all units being operated in heating mode.

• Compressor : Balancing period for [TDF414] seconds → Starting of reversing cycle period by [SDRCT2] min^{-1} for [TSKTM2] seconds → Accelerating by [DFSTEP] min^{-1} / [TDFSPT] seconds in remaining reversing cycle period until defrost MAX speed [DEFMAX] is reached → Balancing period for [TDF415] seconds

• Electric expansion valve

Unit being stopped : [FULL CLOSE] 30 seconds after balancing period has passed → [FULL CLOSE] during reversing cycle period → [PCLOSH\$] 15 seconds before balancing period is finished

Unit being operated : [DFCTPS] 30 seconds before balancing period is finished → Synchronized with step-up of rotation speed of compressor, opened by [DFSPPS] pulses and reaches MAX opening degree [DEFSMX] when rotation speed of compressor reaches [DEFMAX].

RAM-130QH5 DEFROST TEMPERATURE

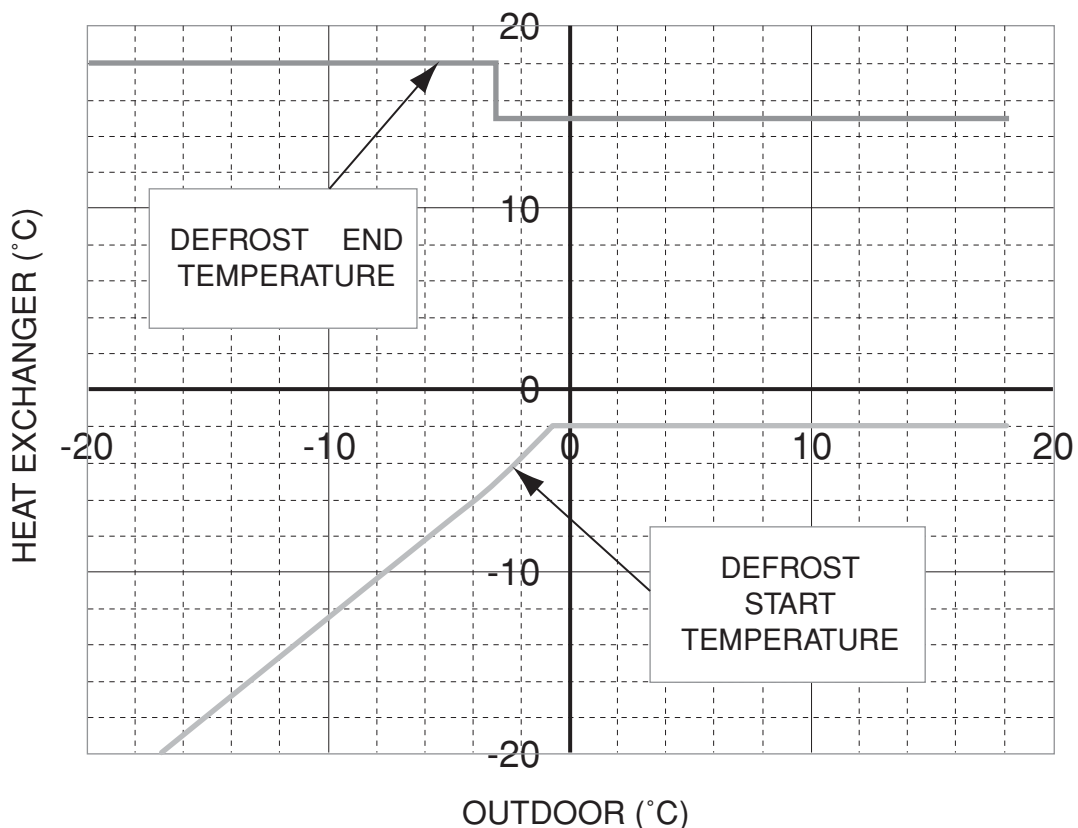

* above graph is showing the ideal value by micon program.

* guaranteed temperature range of this model is -15°C to $+27^{\circ}\text{C}$ at heating.

AUTO-FRESH DEFROST

• During heating operation is stopped, and when auto-fresh condition is established, defrost operation will be performed while operation is stopped.

Auto-fresh consists of balancing period at start of defrost for [TDF414] seconds → Reverse cycle period for MAX 12 minutes.

(1) Start conditions for auto-fresh

- When all the following conditions are established, auto-fresh is executed:
 - ① Defrost request signal is present.
 - ② All indoor units are stopped.
 - ③ 15 minutes of auto-fresh inhibit period has elapsed.
 - ④ Compressor is ON when operation is stopped.
 - ⑤ Compressor delay command is sent from indoor unit when operation is stopped.

(2) Release condition of auto-fresh

- If any one of following conditions is established, auto-fresh is released:
 - ① Heat exchange temperature returns (heat exchange temperature ≥ DEFOFF)
 - ② 12 minutes of defrost MAX time has elapsed.
 - ③ Failure occurred.
 - ④ Either unit 1 or unit 2 or unit 3 or unit 4 or unit 5 or unit 6 started operation.
- ※ Released during start of balancing period : Stopped or started after remaining balancing period has elapsed.
- Released during reverse cycle period : Stopped or started after balancing for 3 minutes.

(3) Outputs during auto-fresh

[Indoor unit defrost request]: Transmitted only to unit to which auto-fresh is applied (indoor unit stopped last).

[Compressor]: Accelerated by DFSTEP min⁻¹/TDFSPT seconds and reaches defrost MAX speed [DEFMAX].

[Electric expansion valve]:

Unit auto-fresh not applied: FULL CLOSE when balancing for 30 seconds has elapsed at start of defrost.

Unit auto-fresh applied : Synchronized with step-up of rotation speed of compressor, opened by [DFSPPS] pulses and reaches MAX opening degree [DEFMAX] when rotation speed of compressor reaches [DEFMAX].

(4) Note

- Shifted to auto-fresh in defrost mode when operation is stopped.
- All indoor units must be stopped to fulfill condition for auto-fresh.

If signal is delayed, auto-fresh condition will not be established.

MODEL RAM-130QH5

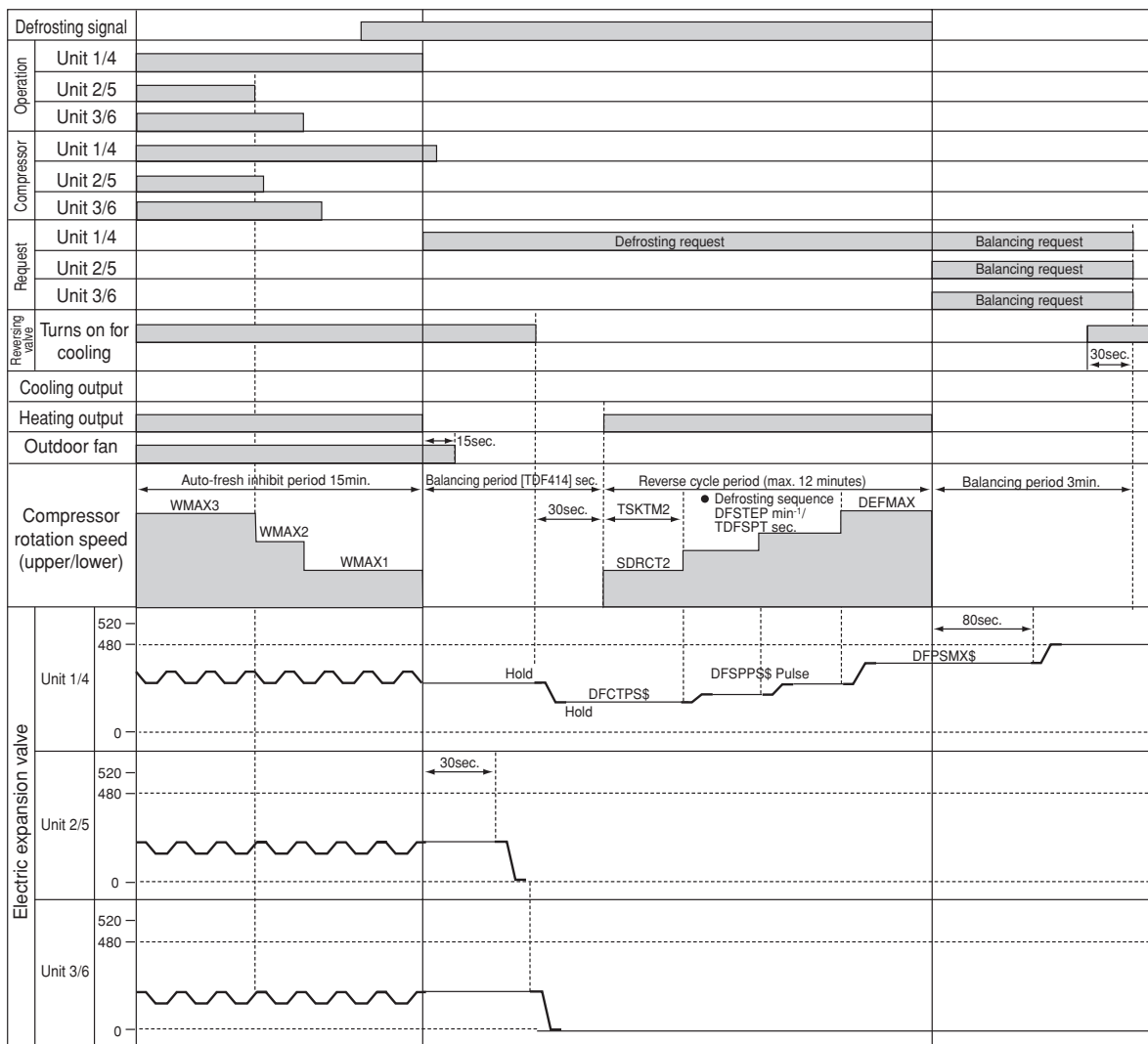

MODEL RAM-130QH5

FORCED COOLING

In order to accumulate refrigerant, units operate in cooling cycle.

Execution condition and operation status are shown below.

[Execution condition]

- With neither indoor unit 1, 2, 3, 4, 5 and 6 not operated, when forced cooling switch is turned ON, forced cooling will be performed.
- Always operation status of indoor units are monitored and forced cooling is inhibited when operation of any unit is detected.

[Operation status]

- Outdoor unit fan: Fixed in LO.
- Compressor rotation speed: Fixed in 3000min⁻¹.
- Expansion valve/reversing valve : Set in normal conditions.

[Note]

- During forced cooling, if failure occurs in outdoor unit, thermostat is turned off. However, it is not counted.
- Since rotation speed of compressor is fixed in 3000min⁻¹ during forced cooling, compressor fixed speed control at start is not performed.

The following shows the operation state of forced cooling.

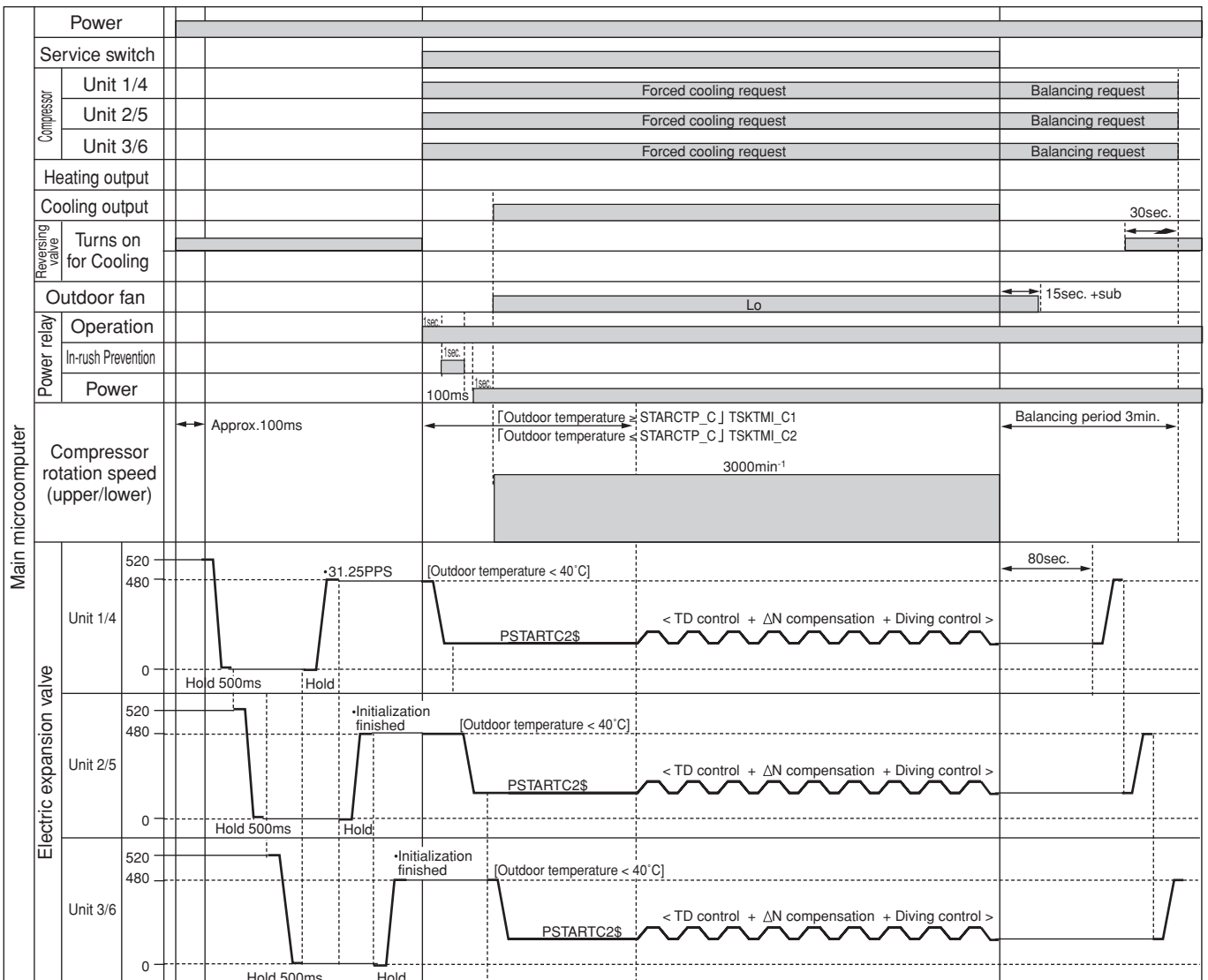

※ TSKTM1_C and PSTARTC2\$ are EEPROM data.

MODEL RAM-130QH5

PROCESSING AT OVERHEAT THERMISTOR (OH) HIGH TEMPERATURE

◇ Restriction Start Conditions

- If any expansion valve is operated at 480 pulses and the OH temperature > [NDOWN_ON], the compressor speed will be reduced at a rate of 100 min⁻¹/30 seconds.
- This reduced rotation speed is based on the speed when the reduction started, and will be maintained until the reduction is finished. However, the reference speed will be exchanged only if the target speed is lower than the speed when the reduction started.
- If [NDOWN_OFF] ≤ OH temperature ≤ [NDOWN_ON] and the OH temperature does not rise from that 20 seconds before, the reduction of compressor speed will not occur.

◇ Restriction Release Condition (in common for all)

- The restriction will be released when OH temperature < [NDOWN_OFF], and the compressor speed will be increased at a rate of 50 min⁻¹/30 seconds to restore the target speed.

When three units are operated for heating:

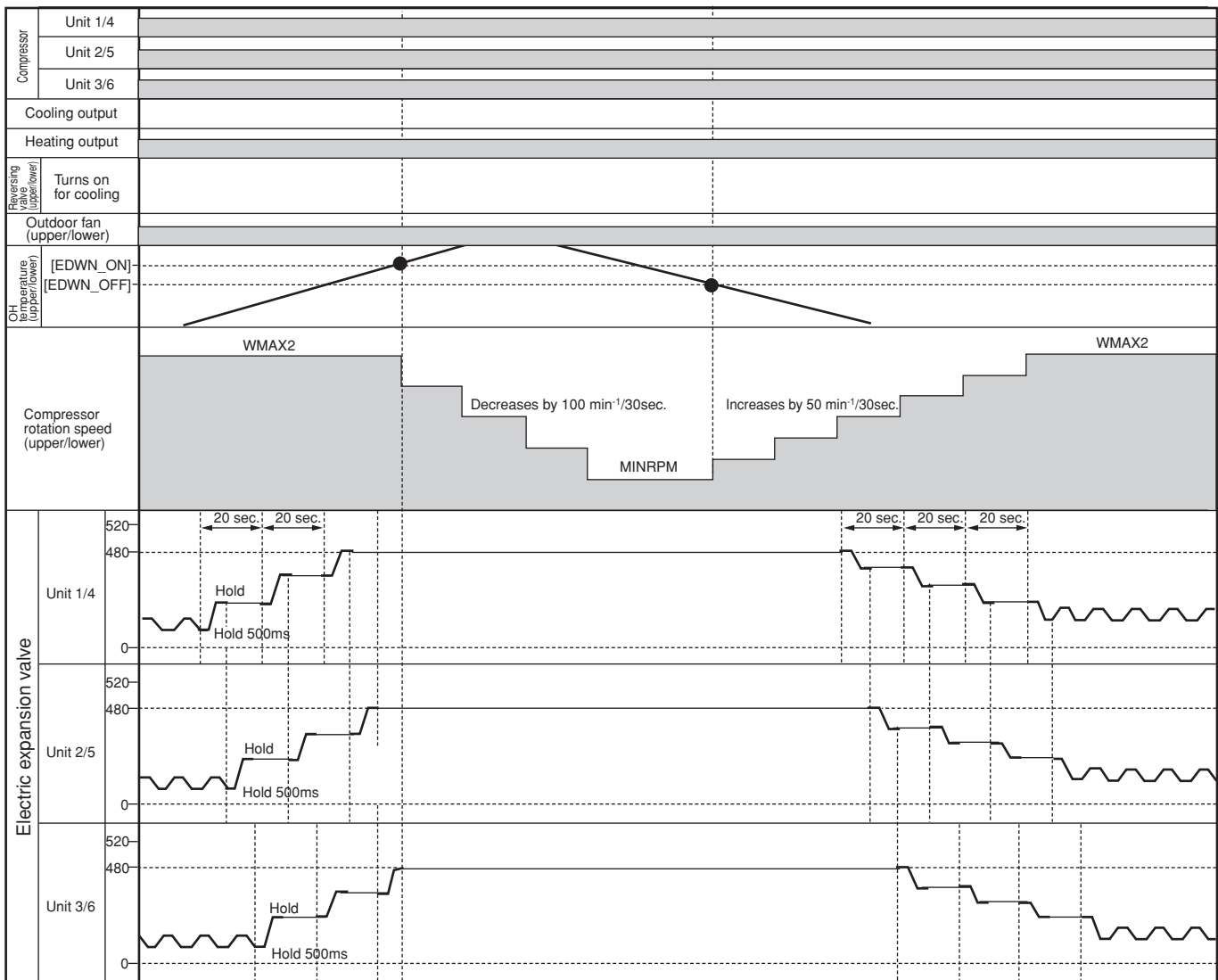

- ※ Operation with one unit in heating or cooling mode and with two units in cooling mode is the same as in the above diagram.
- WMAX2 and MINRPM are EEPROM data.

REFRIGERATING CYCLE DIAGRAM RAM-130QH5

Cooling, Dehumidifying, Defrosting

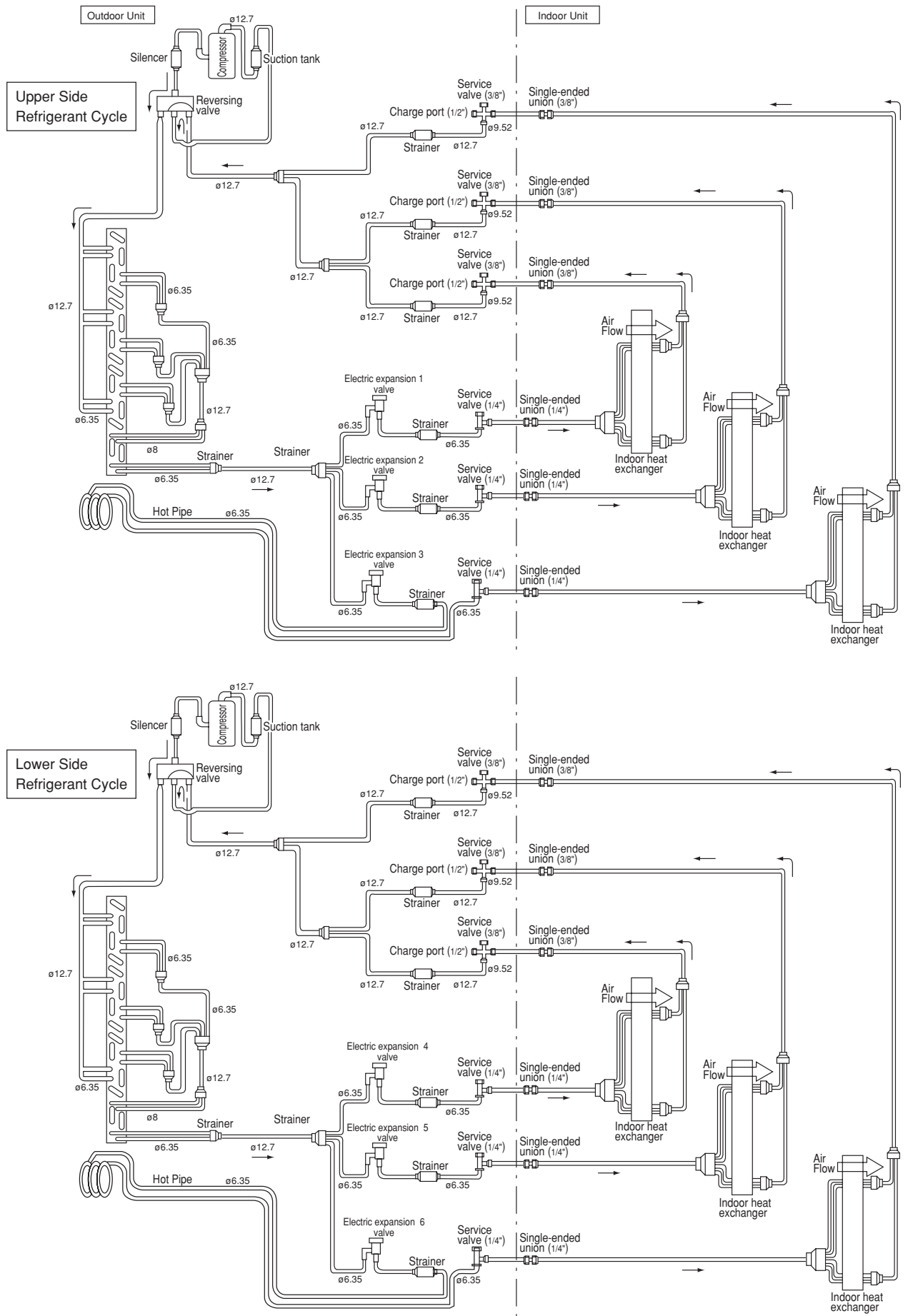

REFRIGERATING CYCLE DIAGRAM RAM-130QH5

Heating

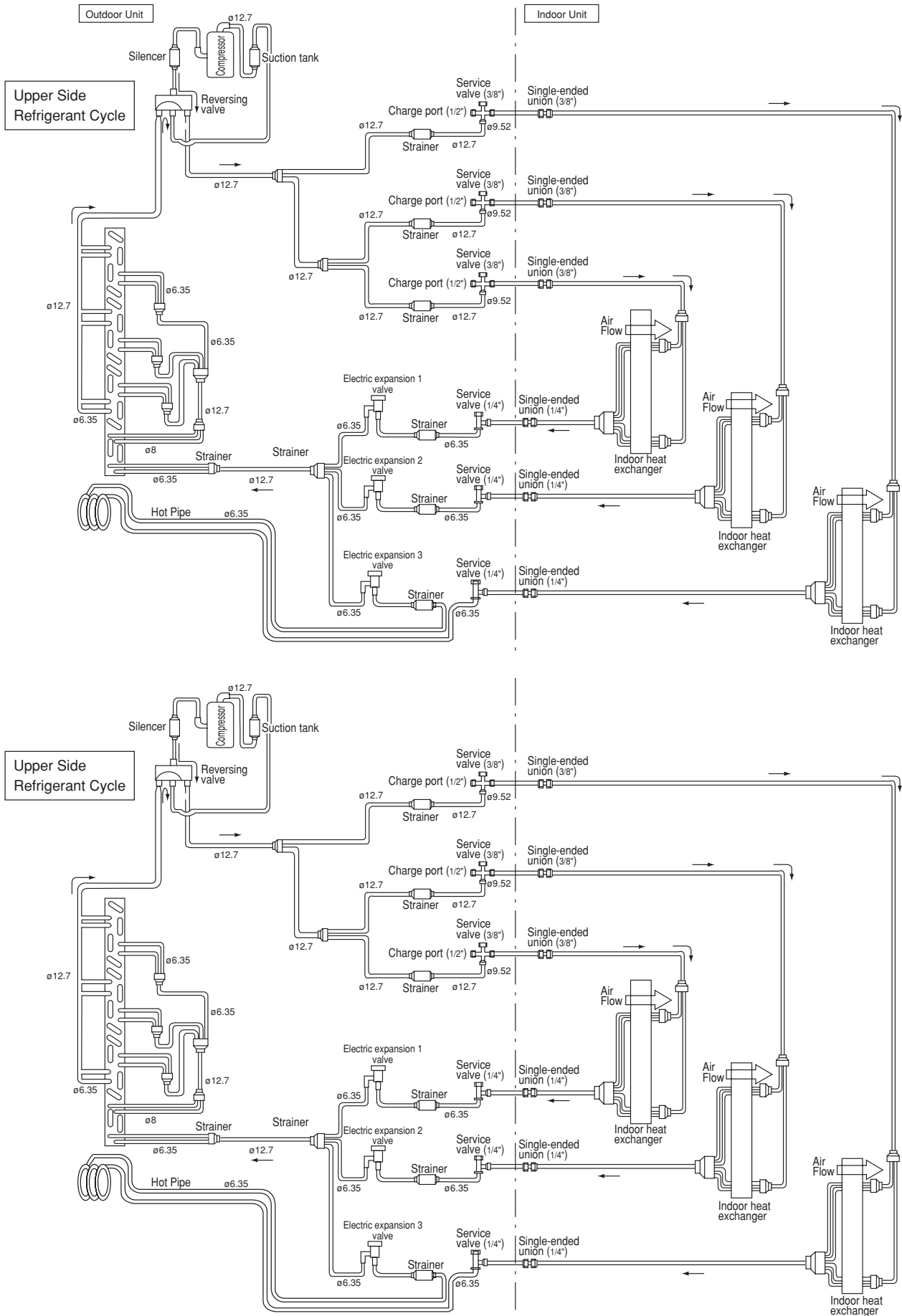

DESCRIPTION OF MAIN CIRCUIT OPERATION

RAM-130QH5

1. Power Circuit

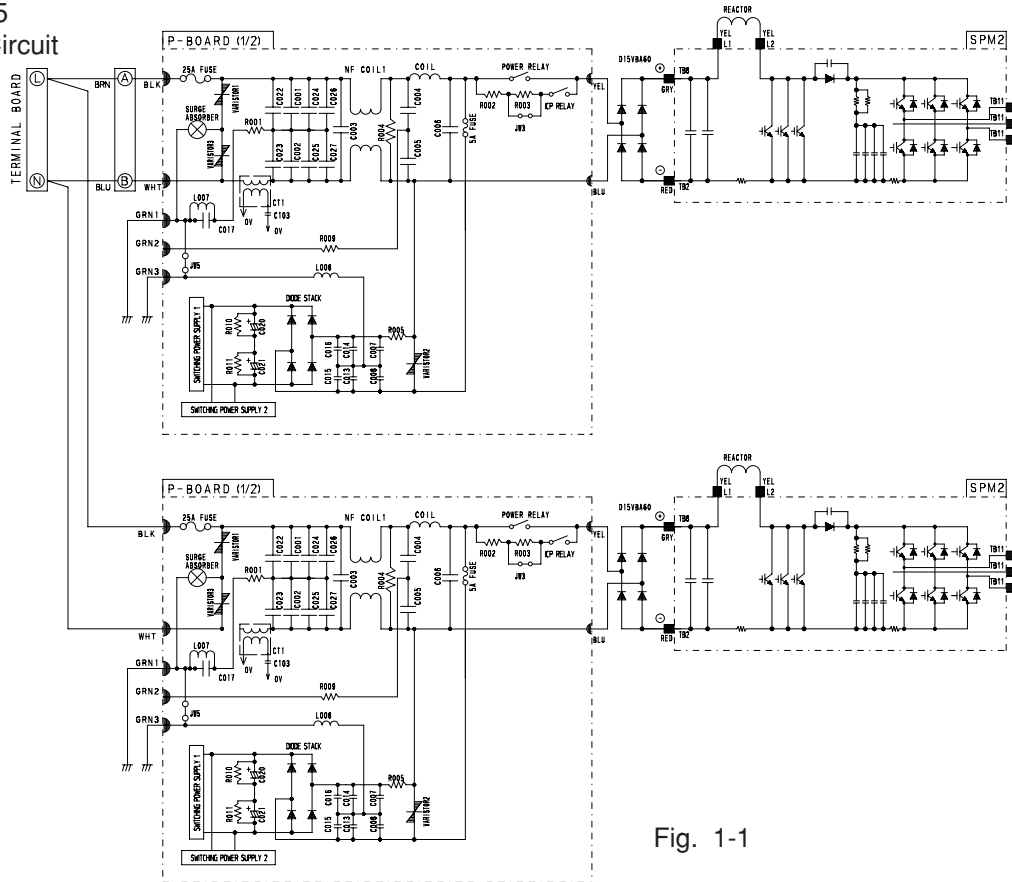

Fig. 1-1

- This circuit full-wave rectifies 220-240 AC applied between terminals L and N, and boosts it to a required voltage with the active module, to create a DC voltage.

The voltage becomes 320-360V when the compressor is operated.

- (1) System power module (SPM)
(Current ACT module, smoothing capacitors and power module are combined into one unit)
- ① Active module
The active filter, consisting of a reactor and switching element, eliminates higher harmonic components contained in the current generated when the compressor is operated, and improves the power-factor. Smoothing capacitor smoothes voltage, which has been rectified by diode stack and boosted at ACT section.
- ② Power module section
Refer to Item 3 System Power Module Circuit.
- (2) These rectify the 220-240V AC from terminals L and N to a DC power supply.

< Reference >

- In case of malfunction or defective connection: Immediately after the compressor starts, it may stop due to "abnormally low speed" active error, etc.
The compressor may continue to operate normally, but the power-factor will decrease, the operation current will increase, and the overcurrent breaker of the household power board will probably activate.
- In case of active module faulty or defective connection:
Although the compressor continues to operate normally, the power-factor will decrease, the operation current will increase, and the overcurrent breaker of the household power board will probably activate.

< Reference >

- If D15VBA60 is faulty, the compressor may stop due to "lp", "abnormally low speed", etc. immediately after it starts, or it may not operate at all because no DC voltage is generated between the positive e and negative d terminals.
If diode bridge 1 is faulty, be aware that the 25A fuse might also have blown.
- If diode stack is faulty, DC voltage may be not generated and the compressor may not operate at all. Also, be aware that the 5A fuse might have blown.

(3) Smoothing capacitor (C501, C502, C503, 400 μ F, 450V)

This smoothes (averages) the voltage rectified by the diode stacks.

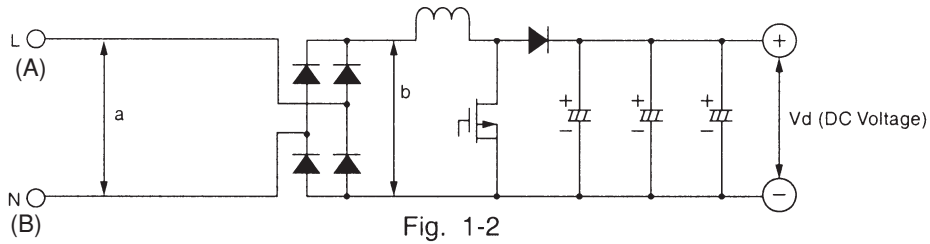

Fig. 1-2

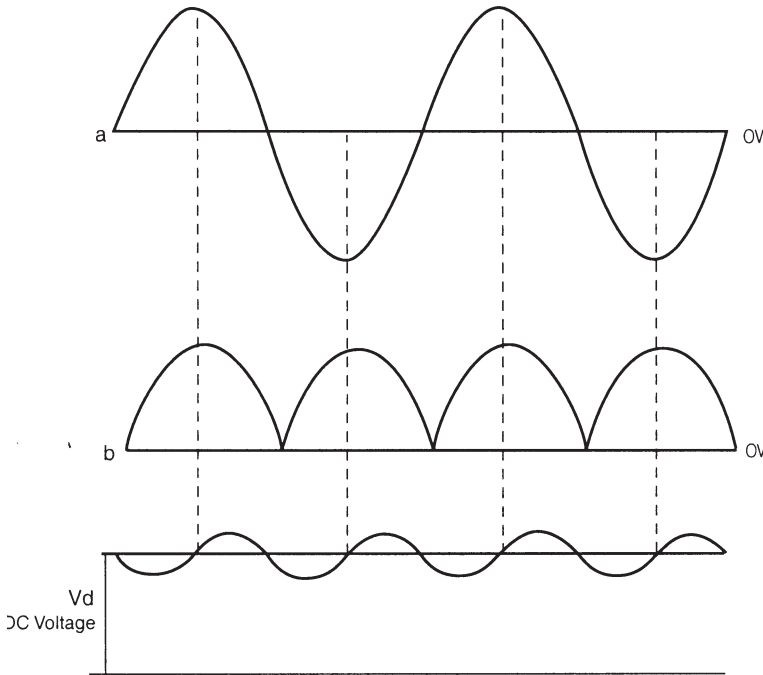

Fig. 1-3

(Approx. 300-330V during operation)

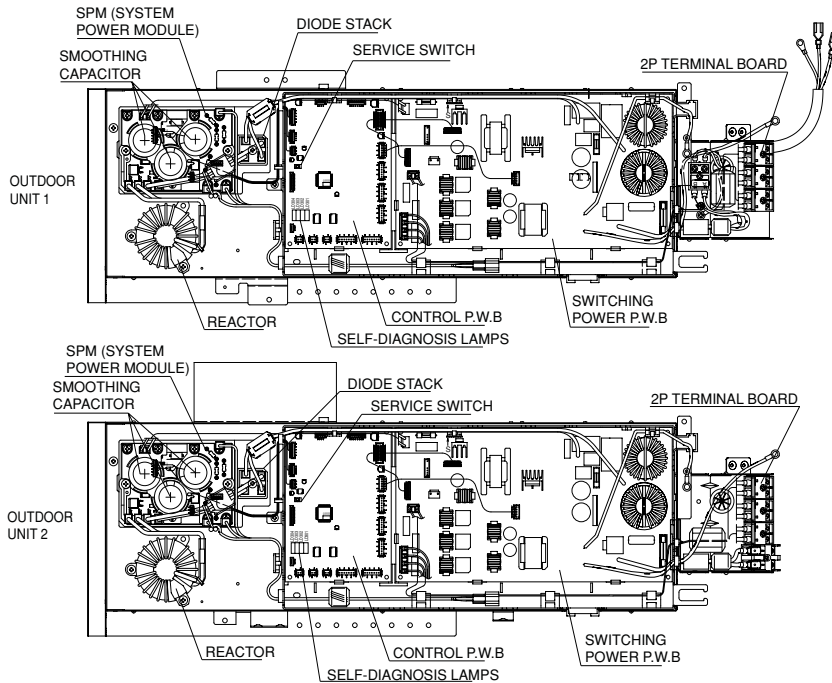

Fig. 1-4

- Be careful to avoid an electric shock as a high voltage is generated. Also take care not to cause a short-circuit through incorrect connection of test equipment terminals. The circuit board could be damaged.

(4) Smoothing capacitor (C020, C021, 220 μ F, DC 250V)

This smoothes (averages) the voltage rectified by the diode stacks.

A DC voltage is generated in the same way as in Fig. 1-3. Voltage between C020 \oplus side and C021 \ominus side is about 330V.

- (5) C001 to C016, NF COIL1
These absorb electrical noise generated during operation of compressor, and also absorb external noise entering from power line to protect electronic parts.
- (6) Surge absorber, Varistor 1, 2, 3,
These absorbs external power surge.
- (7) Inrush protective resistor (R020)
This works to protect from overcurrent when power is turned on.

- * Be sure to ground outdoor unit.
If not grounded, noise filter circuit does not operate correctly.
- * If outdoor unit is not grounded, "surge absorber", "varistors 1 and 3" do not operate.
Be sure to perform grounding.

< Reference >

- When inrush protective resistor is defective, D15VBA60 may malfunction. As a result, DC voltage is not generated and no operation can be done. In this case, 5A fuse may have been blown. Take care.

2. Indoor/Outdoor Interface Circuit

- The interface circuit superimposes an interface signal on the 35V DC line supplied from the outdoor unit to perform communications between indoor and outdoor units. This circuit consists of a transmitting circuit which superimposes an interface signal transmit from the microcomputer on the 35V DC line and a transmitting circuit which detects the interface signal on the 35V DC line and outputs it to the microcomputer.
- Communications are performed by mutually transmitting and receiving the 4-frame outdoor request signal one frame of which consists of a leader of approx. 100 ms., start bit, 8-bit data and stop bit and the command signal with the same format transmit from the indoor unit.
- From outdoor microcomputer to indoor microcomputer.
The request signal output from microcomputer pin (73), (74), (9) is input to the transmitting circuit. The transmitting circuit modulates this signal by approx. 38kHz high-frequency. This high-frequency signal is amplified by a transistor, superimposed on the DC 35V line via C801 (or C811, C821) and L801 (or L802, L803), and supplied to the indoor unit.
To prevent erroneous reception, the outdoor microcomputer is designed so that it cannot receive a signal while it is outputting a request signal.
The receiving circuit in the indoor unit consists of a comparator and transistor. The interface signal from the outdoor unit on the DC 35V line is supplied to C821, where DC components are eliminated, and is then shaped by the comparator. The shaped signal is detected by diode, amplified by amp, and supplied to receiving input of the indoor microcomputer.
Fig. 2-2 shows the voltages at each component when data is transferred from the outdoor microcomputer to the indoor microcomputer.
- Indoor microcomputer to outdoor microcomputer.
The communications from the indoor microcomputer to the outdoor micro computer are the same. Fig. 2-3 shows the voltages and waveforms at each circuit.

- Fig. 2-1 shows the interface circuit used for the indoor and outdoor microcomputers to communicate with each other.

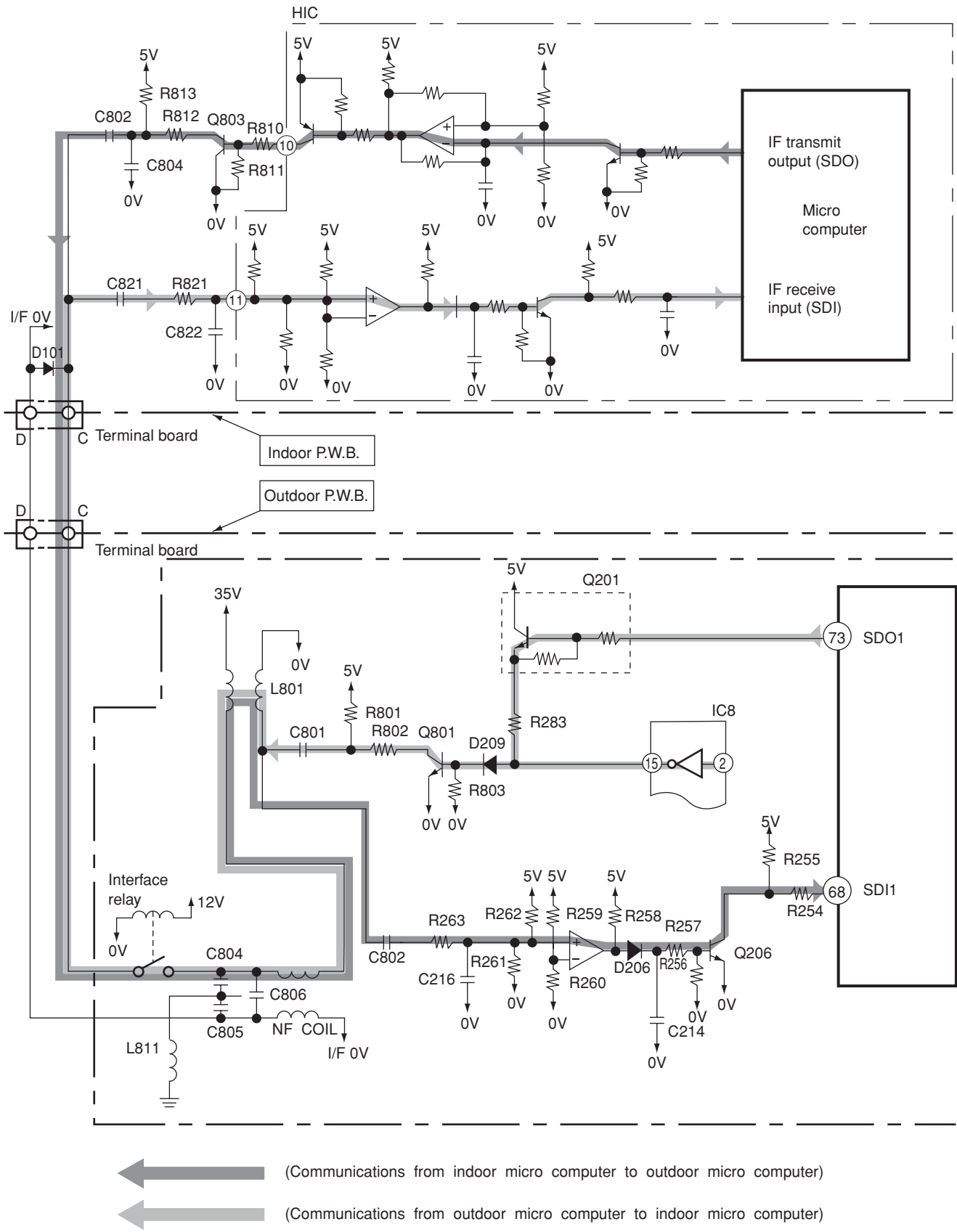

Fig. 2-1 Indoor / Outdoor interface Circuit

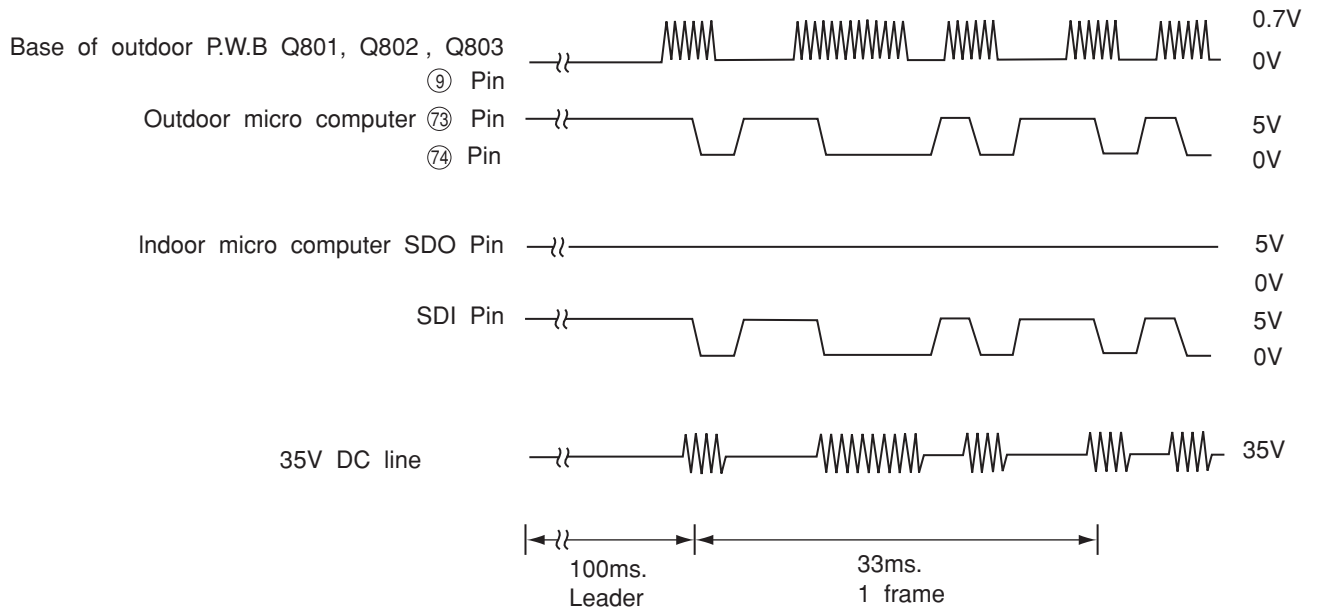

Fig. 2-2 Voltages Waveforms of indoor / Outdoor Micro computers (Outdoor to Indoor Communications)

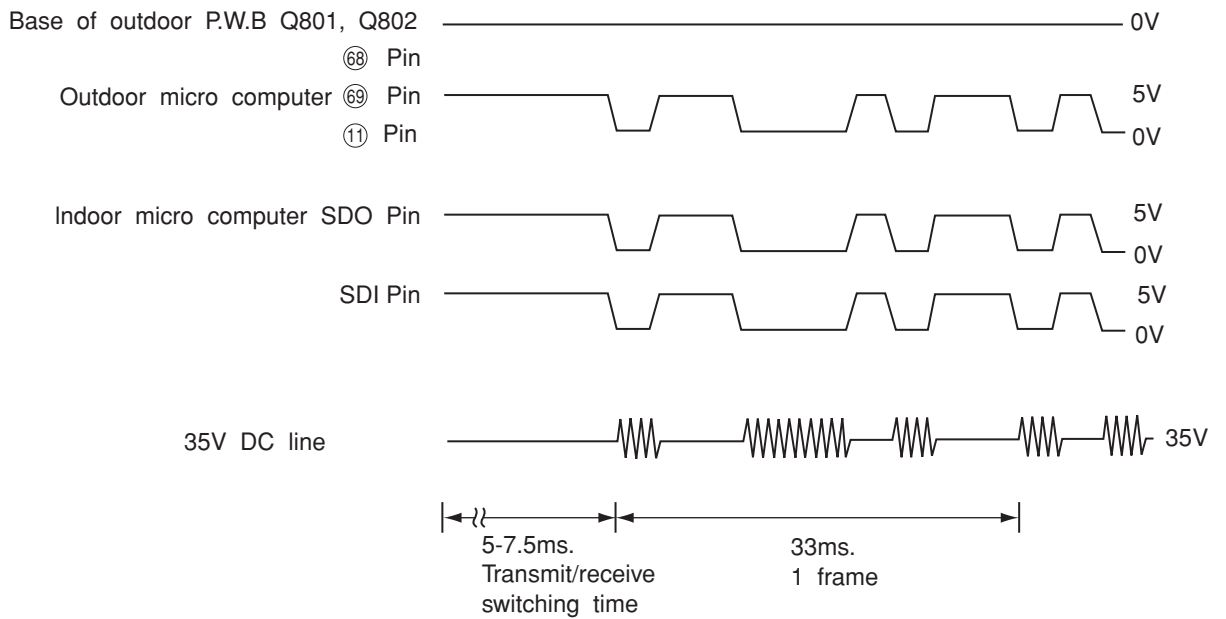

Fig. 2-3 Voltages Waveforms of indoor / Outdoor Micro computers (Indoor to Outdoor Communications)

3. System power Module Circuit

- Fig. 3-1 shows the system power module and its peripheral circuits. (Current ACT module and power module are combined into one unit.) The three transistors on the positive ⊕ side are called the upper arm, and the three transistors on the negative ⊖ side, the lower arm.

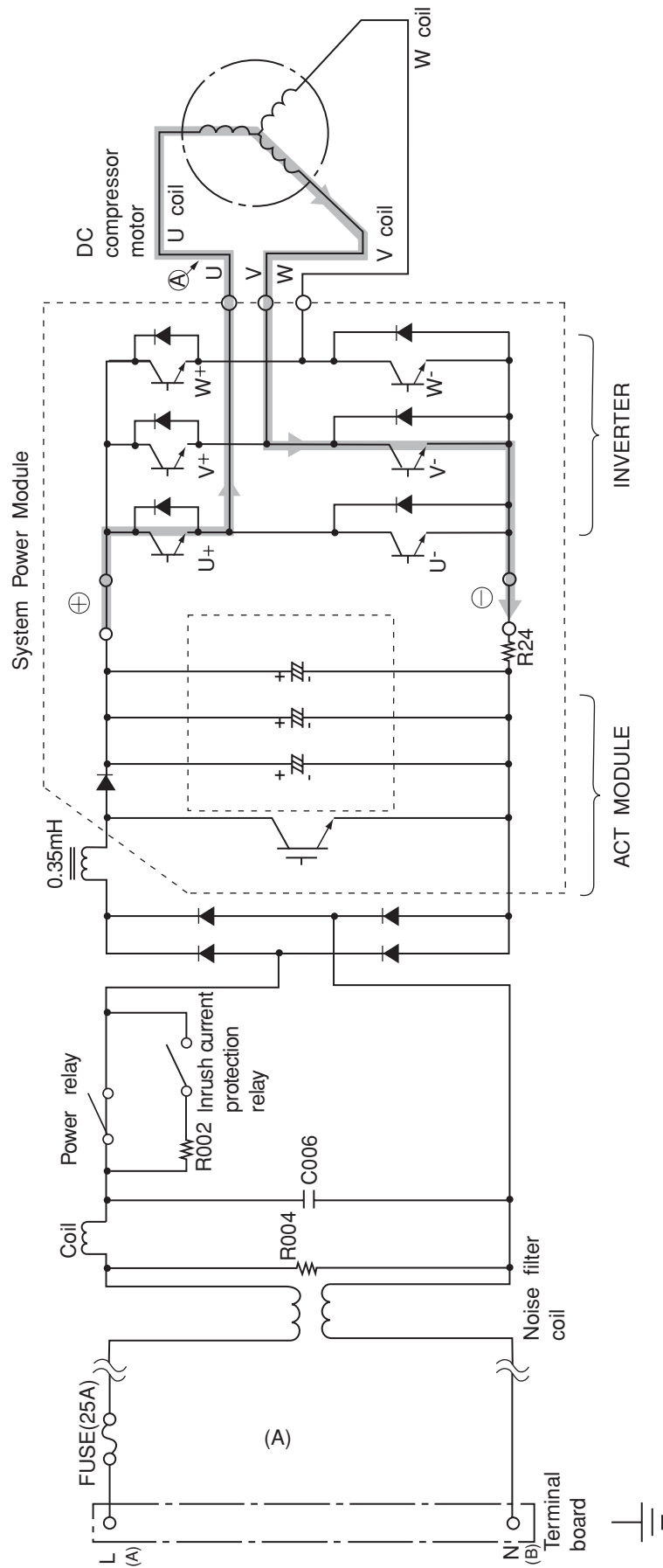

Fig. 3-1 System power module circuit (U⁺ is ON, V⁻ is ON)

- DC 320-360V is input to power module and power module switches power supply current according to rotation position of magnet rotor. The switching order is as shown in Fig. 3-2.

※ At point E: U⁺ is ON, V⁻ is ON (circuit in Fig. 3-1)
 ※ At point F: U⁺ is chopped (OFF), V⁻ is ON (circuit in Fig. 3-4)

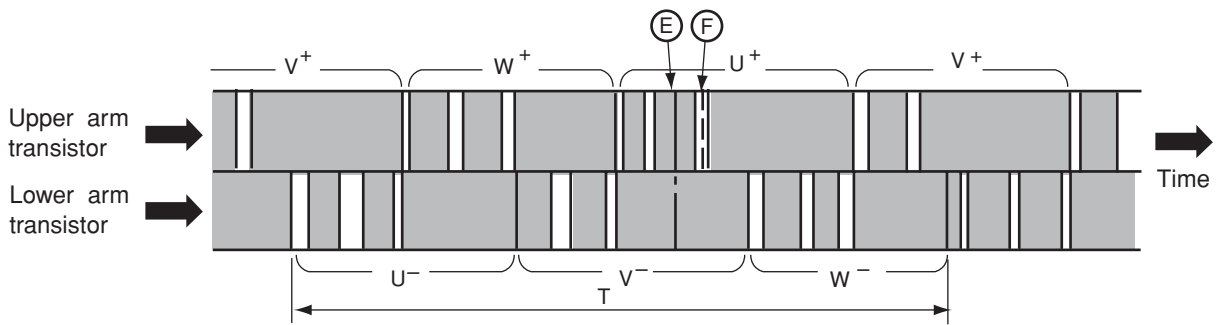

Fig. 3-2 Switching order of power module

- Upper arm transistor is controlled to ON/OFF by 3.2kHz chopper signal. Rotation speed of the compress is proportional to duty ratio (ON time/ ON time + OFF time) of this chopper signal.
- Time T in Fig. 3-2 shows the switching period, and relation with rotation speed (N) of the compressor is shown by formula below;

$$N = 60/2 \times 1/T$$

- Fig. 3-3 shows voltage / current waveform at each point shown in Figs. 3-1 and 3-4. First half of upper arm is chopper, second half is ON, and first half of lower arm is chopper, second half is ON.

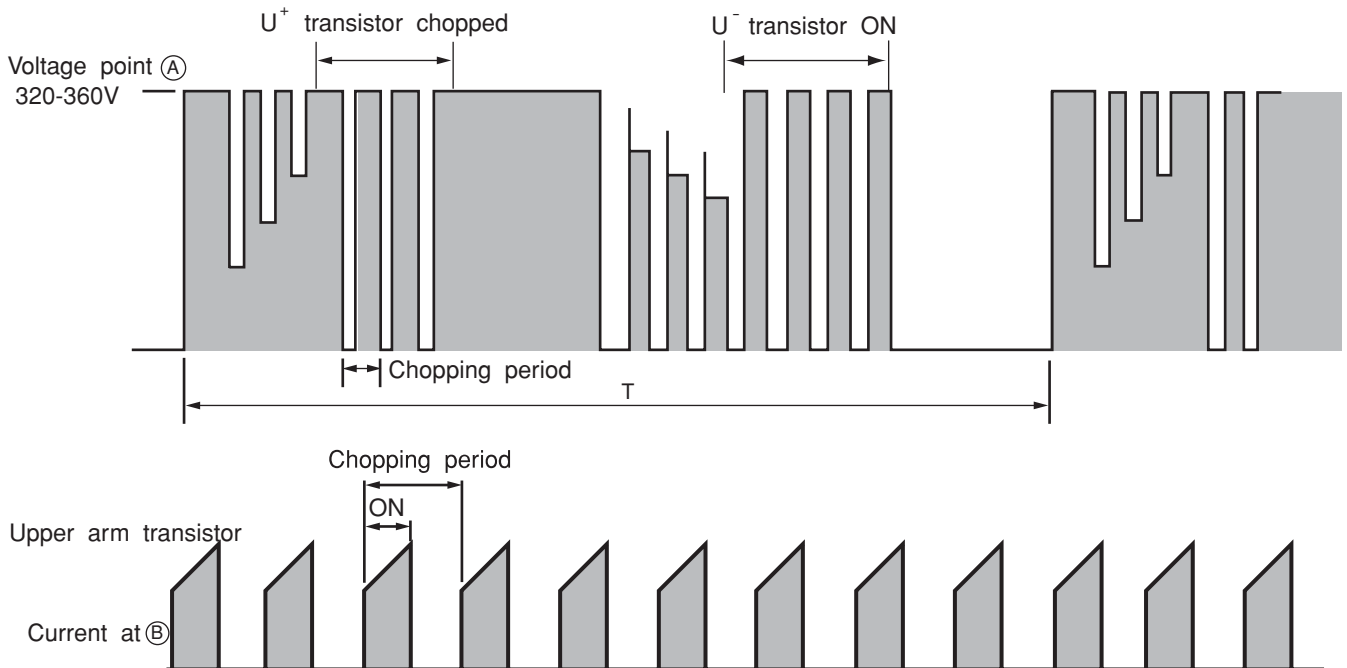

Fig. 3-3 Voltage waveform at each point

- When power is supplied U⁺ → U⁻, because of that U⁺ is chopped, current flows as shown below; ㊸
 - (1) When U⁺ transistor is ON: U⁺ transistor → U coil → V coil → V⁻ transistor → DC current detection resistor → Point ㊸ (Fig. 3-1)
 - (2) When U⁺ transistor is OFF: (by inductance of motor coil) U coil → V coil → V⁻ transistor → Return diode → Point ㊸ (Fig. 3-4)

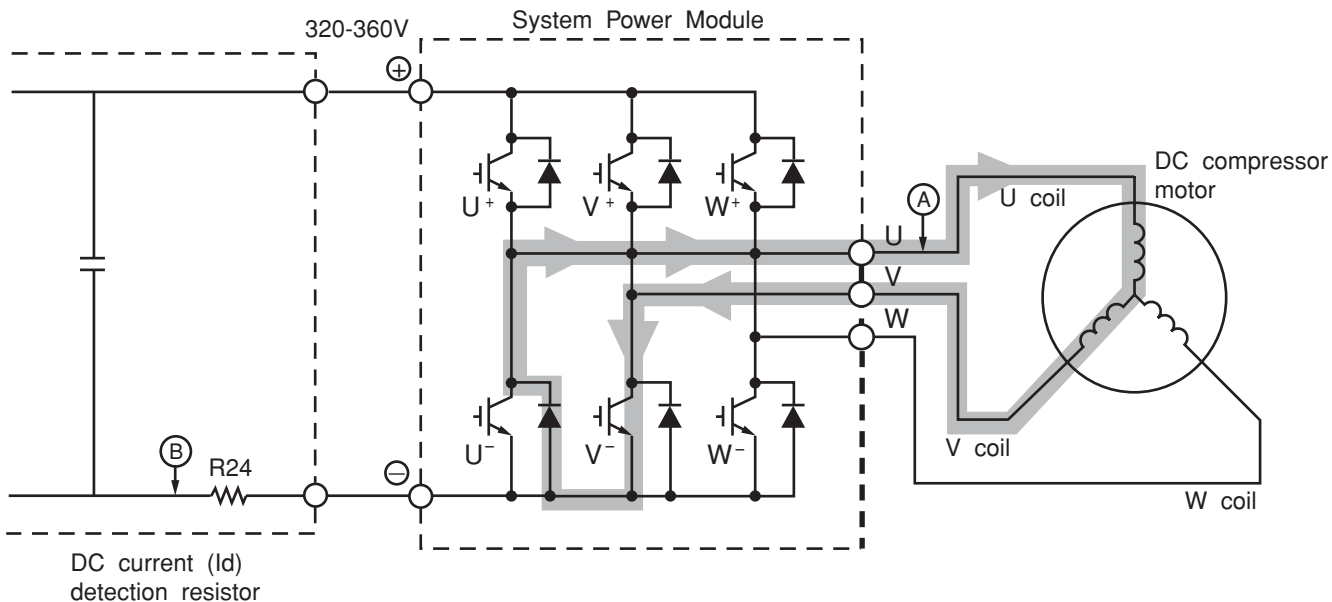

Fig. 3-4 System Power module circuit (U⁺ is OFF, V⁻ is ON)

- Since current flows at point ② only when U⁺ transistor and V⁻ transistor is ON, the current waveform at point ② becomes intermittent waveform as shown in Fig. 3-3. Since current at point ② is approximately proportional to the input current of the air conditioner, input current is controlled by using DC current (Id) detection resistor.

<Reference>

If power module is defective, self diagnosis lamps on the control P.W.B. may indicate as shown below:

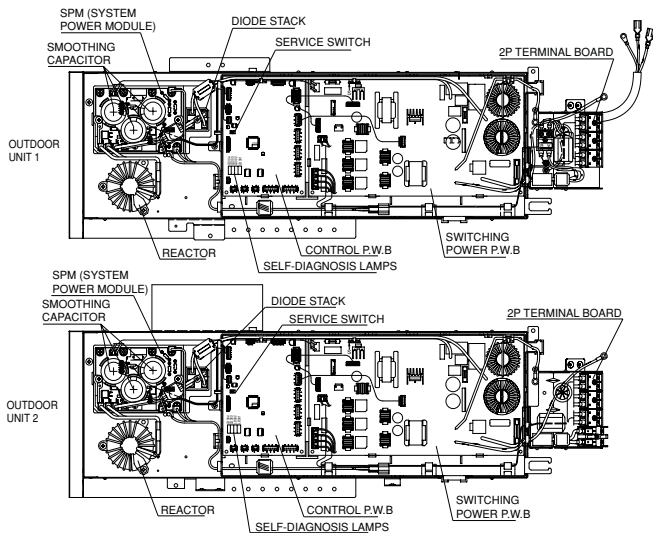

Fig. 3-5

Table 3-1

Self-diagnosis	Self-diagnosis lamp and mode	
I _p (peak current cut)	LD301	Blinks 2 times
Abnormal low speed rotation	LD301	Blinks 3 times
Switching incomplete	LD301	Blinks 4 times

※ From results of power module simple inspection (inspection mode when operated with compressor lead disconnected), LD310 blinks four times about 2 seconds later: Unit has not entered the normal operation.

4. Power Supply Circuit

- Fig. 4-1 shows the power circuit.

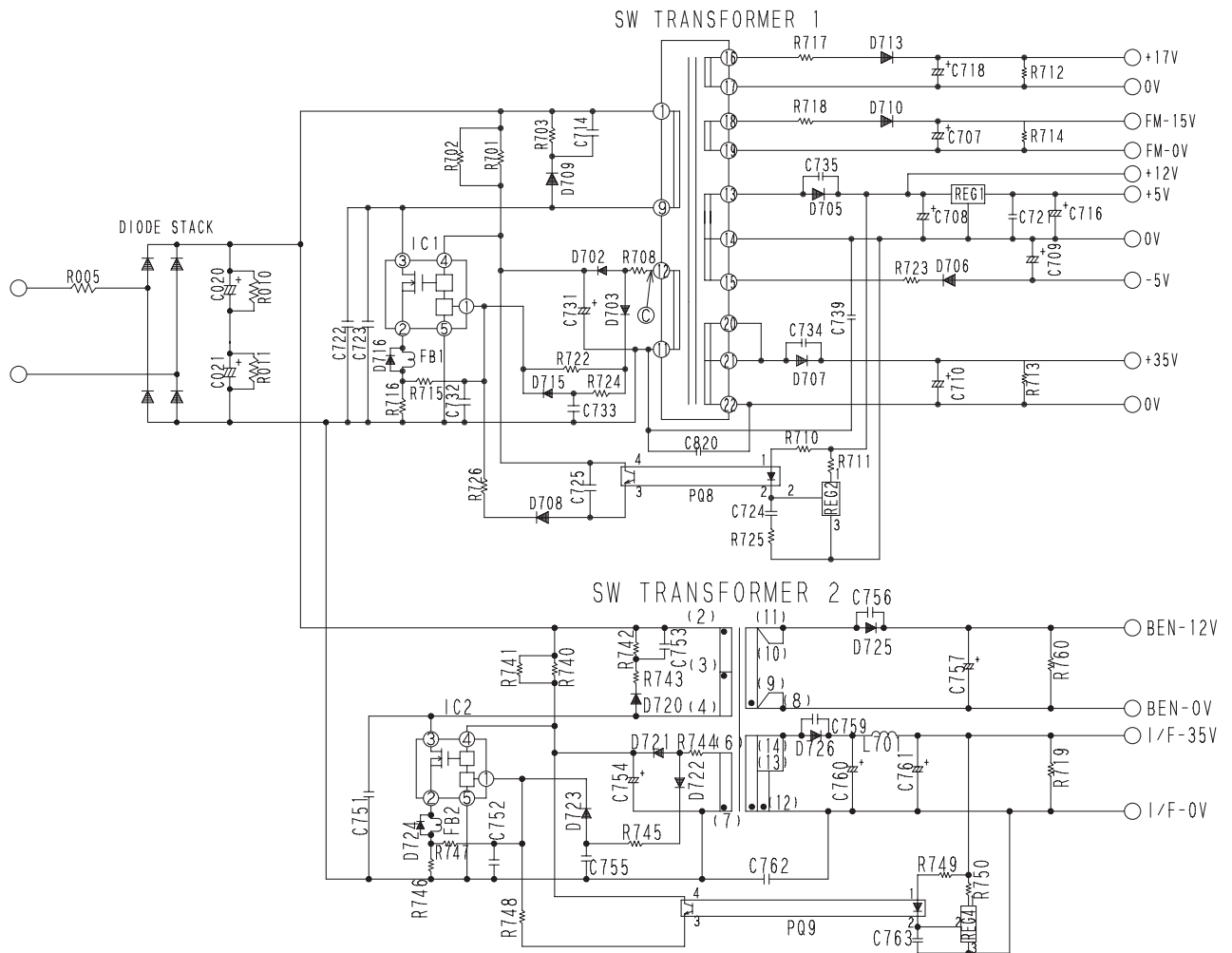

Fig. 4-1 Power circuit for P.W.B.

- There are two switching power supply in Power PWB.
- Switching power supply 1 is generating the secondary power for control circuits and DC35V indoor unit 1.
- Switching power supply 2 is generating the DC12V for expansion valve and DC35V for indoor unit 2 and 3.
- Switching power supply performs voltage conversion effectively by switching transistor IC1 to convert DC330V to high frequency of approximately 20kHz to 200kHz.
- Transistor IC1 operates as follows:

(1) Shifting from OFF to ON

- DC about 330V is applied from smoothing capacitors C020 ⊕ and C021 ⊖ in the control power circuit. With this power, current flows to pin ④ of IC1 via R701 and IC1 starts to turn ON. Since voltage in the direction of arrow generates at point ③ at the same time, current passing through R708 and D702 is positive-fed back to IC1.

(2) During ON

- The drain current at IC1 increases linearly. During this period, the gate voltage and current become constant because of the saturation characteristics of the transformer.

(3) Shifting from ON to OFF

- This circuit applies a negative feedback signal from the 12V output. When the voltage across C708 reaches the specified value, REG2 turns on and current flows to PQ8 ①-②. This turns the secondary circuits on, sets IC1 pin ① to "Hi", and turns IC1 off.

(4) During OFF

- While IC1 is on, the following energy charges the primary windings of the transformer:

Energy= $LI^2/2$. Here, L : Primary inductance

I : Current when IC1 is off

This energy discharges to the secondary windings during power off. That is, C707-C710, C718 is charged according to the turn ratio of each winding.

- At the start, an overcurrent flows to IC1 because of the charged current at C707-C710, C718.
- The drain current at IC1 generates a voltage across R716. If it exceeds the IC1 base voltage, it sets the IC gate voltage to "Hi".
- R716 limits the gate voltage to prevent excessive collector current from flowing to IC1.
- This SW power circuit uses a frequency as low as 20kHz, especially at a low load (when both the indoor and outdoor units stop): This reduces power loss in standby status.

<Reference>

- If the power circuit for P.W.B. seems to be faulty:

(1) Make sure that 5V, 12V, 15V, 17V and -5V on the control P.W.B. power voltage are the specified values.

(2) When only the 5V output is low:

REG 1 (regulator) faulty, 5V-0V shorted, output is too high, or REG 1 is abnormal.

(3) When 12V and 5V are abnormal:

The following defects can be considered:

① Fan, operation, power, rush prevention relay (shorting in relay, etc.)

② REG 1 (regulator is abnormal), etc.

Shorting on primary circuits.

When shorting occurs in the secondary circuits, there is no abnormality in the primary circuits because of overcurrent protection.

The voltage rises when an opening occurs in the primary circuits, or the feedback system is abnormal.

(4) When 15V and 17V power supply is abnormal:

D710, D713 or Drive circuit is abnormal.

(5) When all voltage are abnormal:

IC1, R716, may possibly be defective. Also D cable may possibly be reverse connected.

If IC1 is abnormal, be aware that other components, such as the power module, REG (regulator), etc. are possibly defective.

[When the switching power supply seems to be abnormal, the voltage between IC1 pin ④ (to be measured at the leads of R9701 and R702) and IC1 pin ⑤ (to be measured at R216 lead) may be between 11 and 16V. This is because the protection circuit of IC1 is operating.]

5. Reversing valve control circuit

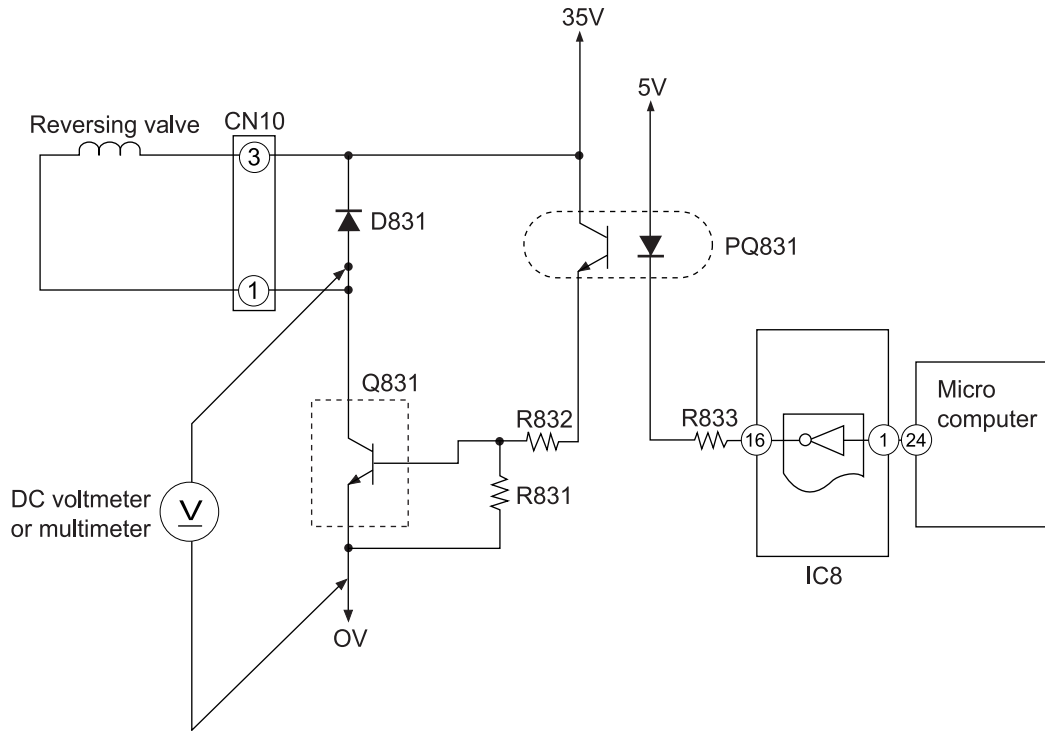

Fig. 5-1

Since the reversing valve is differential pressure system, even when reversing valve is ON (collector of Q831 is about 0.8V normally), compressor rotation speed instructed by indoor microcomputer exceeds 3300min^{-1} , signal at pin of ⑳ microcomputer changes, and collector voltage of Q831 will be about 35V. This does not indicate trouble. When rotation speed is reduced under 2700min^{-1} , collector voltage of Q831 will fall to about 0.8V again. To measure voltage, connect ⊕ terminal of tester to D831 anode and ⊖ terminal to D line on the terminal board.

- By reversing valve control circuit you can switch reversing valve ON/OFF (cooling ON) according to instruction from indoor microcomputer and depending on operation condition. Voltage at each point in each operation condition is approximately as shown below when measured by tester. (When collector voltage of Q831 is measured)

Table 5-1

Operation condition		Collector voltage of Q831
Cooling	General operation of cooling	About 0.8V
Heating	In normal heating operation	About 35V
	MAX. rotation speed instructed by indoor microcomputer after defrost is completed	About 35V
	Defrosting	About 0.8V
Dehumidifying	Sensor dry	About 0.8V

7. Peripheral circuit of microcomputer

- Fig. 7-1 shows the microcomputer and its peripheral circuits.
Table 7-1, the basic operations of each circuit block, and Fig. 7-2, the system configuration.

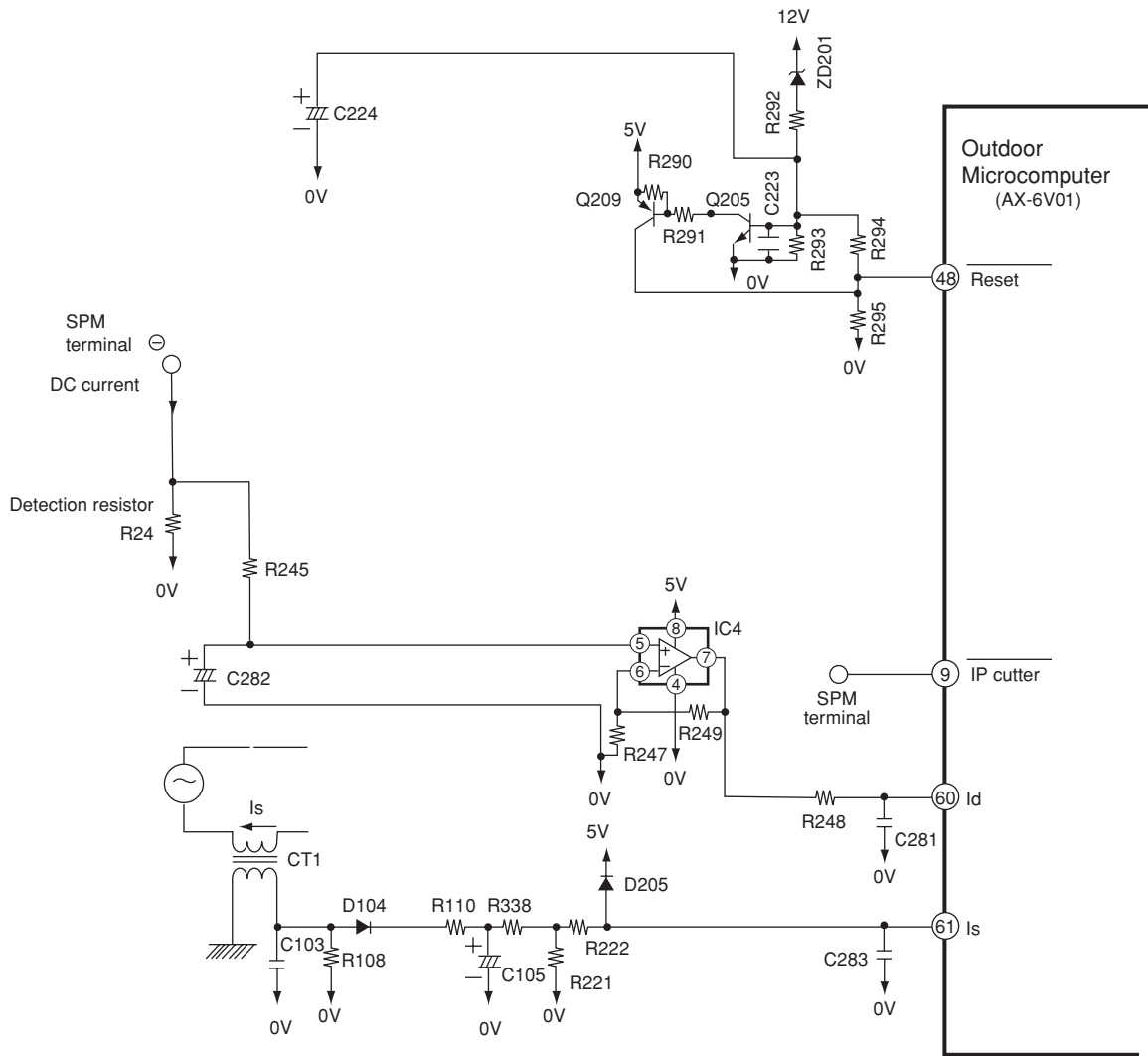

Fig. 7-1 Peripheral circuit of microcomputer (AX-6V01)

Table 7-1

Circuit block	Basic operation
Peak current cut off circuit	This circuit detects DC current flowing power module: When over-current (instantaneous value) flows, it stops upper and lower arm drive circuit and also produces Ip signal to stop microcomputer.
Overload external judgment circuit	This circuit detects DC current flowing to power module and produces signal to notify microcomputer of overload status.
Voltage amplifier circuit	This circuit voltage-amplifies DC current level detected by detection resistor and sends it to microcomputer. In addition, setting of internal/external overload judgment is performed.
Reset circuit	This circuit produces reset voltage.

8. Overload control circuit (OVL control circuit)

- Overload control is to decrease the speed of the compressor and reduce the load when the load on the air conditioner increases to an overload state, in order to protect the compressor, electronic components and power breaker.
- Overloads are judged by comparing the DC current level and set value.
- Fig. 8-1 shows the overload control system configuration and Fig. 8-2 is a characteristic diagram of overload judgement values. There are two judgement methods-external judgement which compares the externally set value with the DC current value regardless of the rotation speed and internal judgement which compares the set value that according to the rotation speed programmed in the micro computer software with the DC current value.

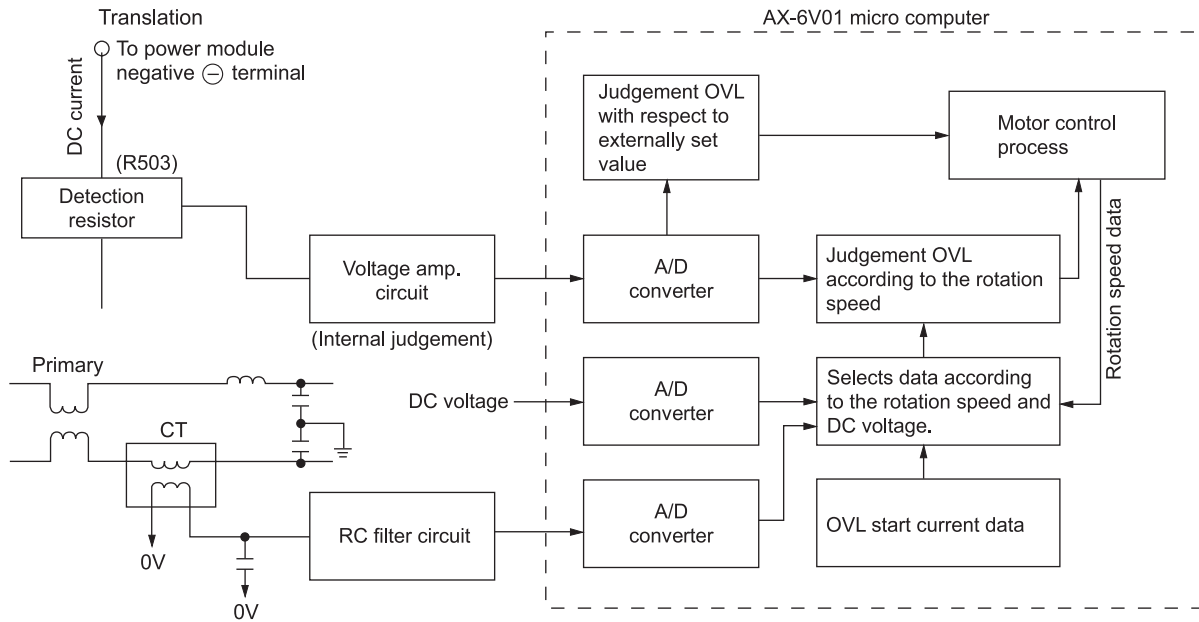

Fig. 8-1 Overload Control System Configuration

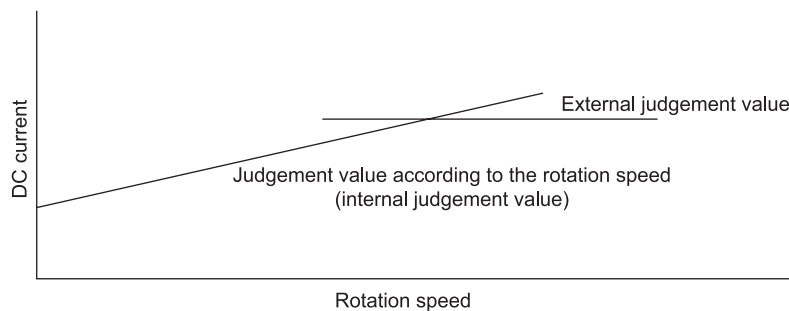

Fig. 8-2

9. Reset circuit

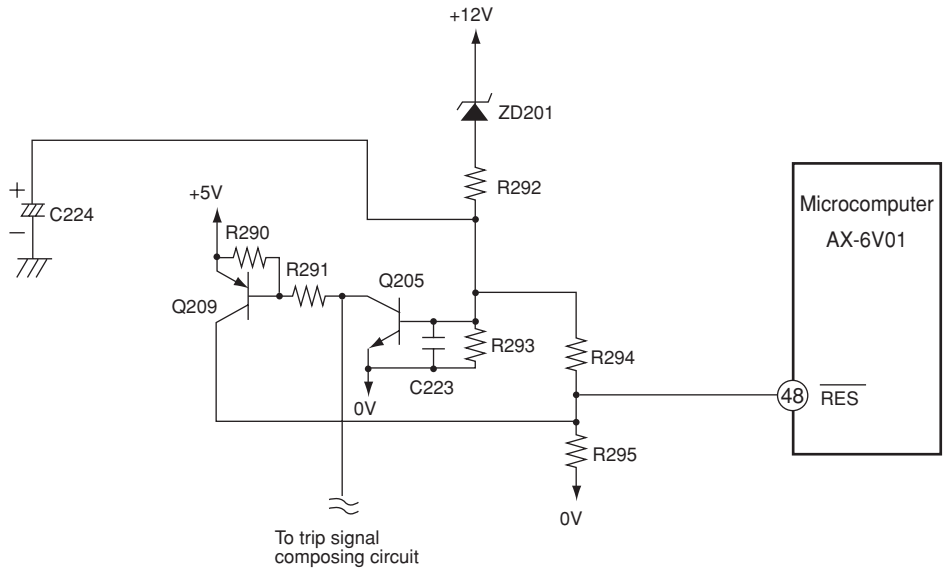

Fig. 9-1 [outdoor unit 1 or outdoor unit 2]

- Reset circuit performs initial setting of microcomputer program when power is turned on.
- Microcomputer resets program with reset voltage set to Lo, to enable operation at Hi level.
- Fig. 9-1 shows reset circuit, and Fig. 9-2 shows waveforms at each point when power is turned on and off.
- After power is turned on, 12V line and 5V line voltages rise: When 12V line voltage reaches 7.2V (Zener voltage of ZD201) ZD201 turns ON and Q208 and Q205 turn on, and reset voltage becomes Hi. Reset voltage is not set to Hi until VDD of microcomputer rises to 5V, enabling operation, due to ZD201.
- After power turns off, when 12V line voltage drops, ZD201 also turns OFF. However, Q208 is left ON since reset voltage is fed back by R294, until 12V line drops to about 7.6V. This prevents chattering of reset voltage due to voltage change in 12V line.

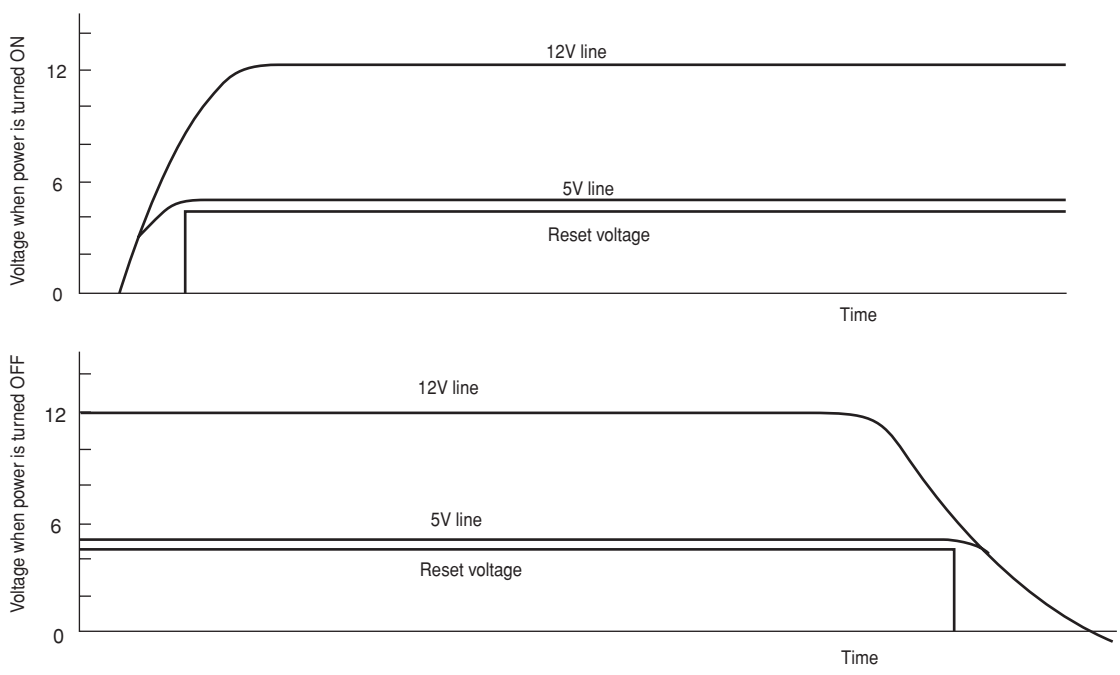

Fig. 9-2

10. Temperature Detection Circuit

- The outdoor units (at PWB OUTDOOR ELECTRICAL UNIT 1 and 2) provides with the outdoor temperature thermistor, DEF (defrost) thermistor, OH (overheat) thermistor and electric expansion valve thermistor so that they detect the temperatures of the unit and control the system.
- The circuit of the thermistors is shown as Fig. 10-1 and their roles and temperature measuring points are shown as Table 10-1.

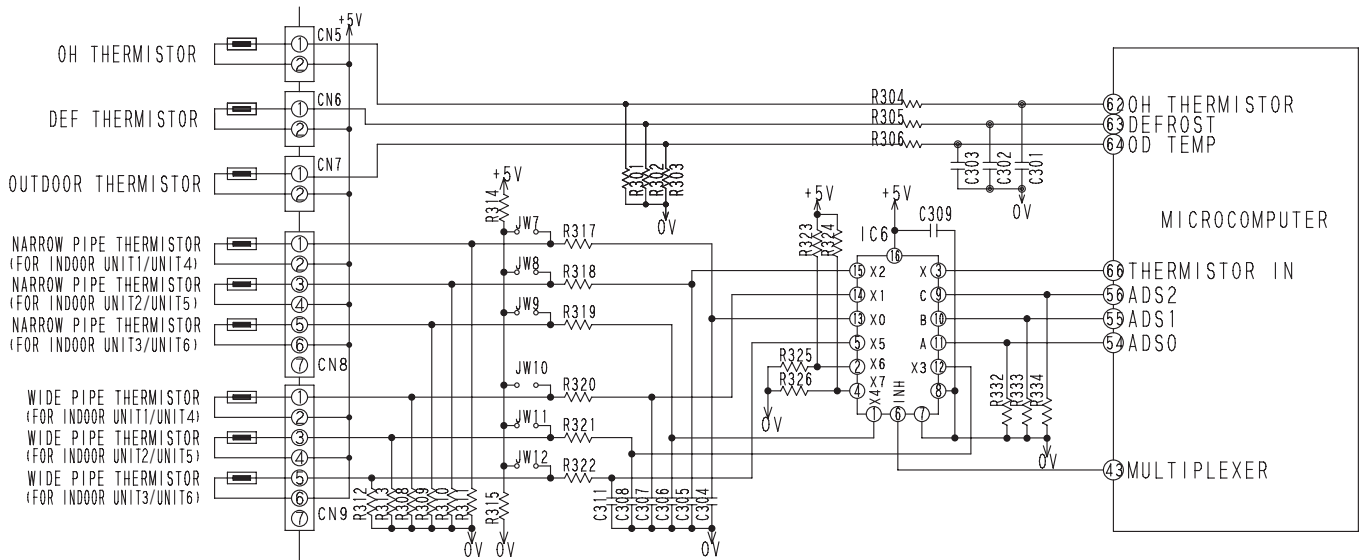

Fig. 10-1 Temperature Detection Circuit

Table 10-1 Name and Role of each thermistor

Name	Connector No	Measuring Point	Role
OH thermistor	CN5	Compressor head	If the temperature of the compressor rises abnormally (118°C), the compressor will be stopped. The temperature is used to decide the operation of the valve.
DEF thermistor	CN6	Heat exchanger	The thermistors decide the defrost operation during heating combined the data of the outside temperature and its data.
Outdoor temperature thermistor	CN7	Outside temperature	Outdoor temperature is used to decide the various operations of the air conditioner.
Electric expansion valve thermistor (NARROW PIPE 1)	CN8	Indoor unit 1 (NARROW PIPE)	The thermistors detect the temperatures of the piping to the indoor units. The temperatures are used to decide how much the expansion valve is opened.
Electric expansion valve thermistor (NARROW PIPE 2)		Indoor unit 2 (NARROW PIPE)	
Electric expansion valve thermistor (NARROW PIPE 3)		Indoor unit 3 (NARROW PIPE)	
Electric expansion valve thermistor (NARROW PIPE 4)		Indoor unit 4 (NARROW PIPE)	
Electric expansion valve thermistor (NARROW PIPE 5)		Indoor unit 5 (NARROW PIPE)	
Electric expansion valve thermistor (NARROW PIPE 6)		Indoor unit 6 (NARROW PIPE)	
Electric expansion valve thermistor (WIDE PIPE 1)	CN9	Indoor unit 1 (WIDE PIPE)	
Electric expansion valve thermistor (WIDE PIPE 2)		Indoor unit 2 (WIDE PIPE)	
Electric expansion valve thermistor (WIDE PIPE 3)		Indoor unit 3 (WIDE PIPE)	
Electric expansion valve thermistor (WIDE PIPE 4)		Indoor unit 4 (WIDE PIPE)	
Electric expansion valve thermistor (WIDE PIPE 5)		Indoor unit 5 (WIDE PIPE)	
Electric expansion valve thermistor (WIDE PIPE 6)		Indoor unit 6 (WIDE PIPE)	

Table 10-2 Correspondence between each thermistor's resistance and temperature (reference value)

- Table 10-2 shows the correspondence between the thermistor's resistance and the temperature. They should be used as reference values. The value, which you measure, may be slightly difference from that in the table. It depends on the instrument.
- When you measure the resistance, pull out the connector after turning off the power supply. Pulling out the connector while the power supply is turned on will cause troubles.

Electric expansion valve thermistor DEF thermistor	Temperature	Resistance	Microcomputer pin potential
	-15°C	12.6kΩ	1.0V
	0°C	6.1kΩ	1.7V
	25°C	2.2kΩ	3.0V
	50°C	860Ω	3.9V
	75°C	400Ω	4.4V
Outdoor temperature thermistor	Temperature	Resistance	Potential
	-15°C	12.6kΩ	1.0V
	0°C	6.1kΩ	1.7V
	15°C	3.2kΩ	2.4V
30°C	2kΩ	3.1V	
OH thermistor	Temperature	Resistance	Potential
	25°C	33.9kΩ	0.5V
	50°C	10.8kΩ	1.3V
	75°C	4.1kΩ	2.4V
	100°C	1.7kΩ	3.4V
	105°C	1.5kΩ	3.6V
118°C	1kΩ	3.9V	

- When the connectors of the thermistors are disconnected or the thermistors is open or short, LD301 (red) lights and LD302 (red) blinks so that they indicate troubled parts. Combinations of LD301 and LD302 are set up for indicating troubled thermistors. The correspondences between the number of blink time and troubled parts are shown as Table 10-3. Look in the table (LD301 and LD302 blink) for troubled parts, and if the disconnections of them are checked out, they are replaced.
- If you can see two or more troubled thermistors, a small number of blink takes precedence of others.
- The electric expansions valve thermistor is put together with 3 pieces, when replacing the thermistor, replace one set of 3 pieces as taking care of positioning. If you don't do so, the unit may not operate normally and its cooling and heating performance may drop.
- Be ware that only an open-circuit for OH thermistor has to be checked in 5 minutes after the compressor starts.
- If the unit operates abnormally after replacing the thermistor, replace the control P.W.B. because it malfunctions.

Table 10-3 LED lighting mode at the thermistors troubled

LED lighting mode		Troubled thermistor	Judgement	
LD301	LD302		Open	Short
Lights	1 blink	OH thermistor	0.04V or less	4.96V or more
Lights	2 blinks	DEF thermistor	0.04V or less	4.94V or more
Lights	3 blinks	Outdoor temperature thermistor		
Lights	4 blinks	Electric expansion value thermistor (thin pipe 1 or thin pipe 4)		
Lights	5 blinks	Electric expansion value thermistor (thick pipe 1 or thin pipe 4)		
Lights	6 blinks	Electric expansion value thermistor (thin pipe 2 or thin pipe 5)		
Lights	7 blinks	Electric expansion value thermistor (thick pipe 2 or thin pipe 5)	0.04V or less	4.94V or more
Lights	8 blinks	Electric expansion value thermistor (thin pipe 3 or thin pipe 6)		
Lights	9 blinks	Electric expansion value thermistor (thick pipe 3 or thin pipe 6)		

- The OH thermistors are detecting the compressor head temperatures. If the temperature rises over 118°C, the compressor in the cycle will be stopped to protect itself and LD301 will blink 6 times (OH STOP). When the compressor temperature falls under 105°C, the compressor will restart. During OH STOP, the fan continues to spin. The other cycles without a trouble operates normally.
- If OH STOP often occurs, the refrigerant may be leaking.

11. Electric expansion valve

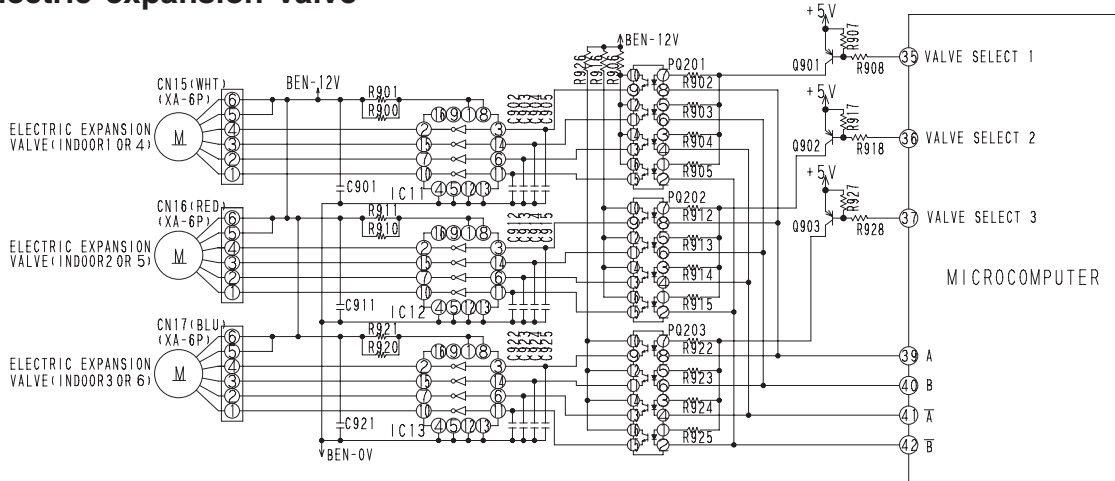

Table 11-1

- The electric expansion valve is driven by DC 12V. Power is supplied to 1 or 2 phases of 4-phase winding to switch magnetic pole of winding in order to control opening degree.
- Relationship between power switching direction of phase and open/close direction is shown below. When power is supplied, voltages at pins 4 to 1 of CN15~CN17 are about 0.9V; they are about 12V when no power is supplied. When power is reset, initialization is performed for 10 or 20 seconds. During initialization, measure all voltages at pins 4 to 1 of CN15~CN17 using mutimeter. If there is any pin with voltage that has not changed from around 0.9V or 12V, expansion valve or microcomputer is defective.
- Fig. 11-2 shows logic waveform when expansion valve is operating.

Table 11-2

Pin phase No.	Lear wire	Drive status							
		1	2	3	4	5	6	7	8
④	White	ON	ON	OFF	OFF	OFF	OFF	OFF	ON
③	Yellow	OFF	ON	ON	ON	OFF	OFF	OFF	OFF
②	Orange	OFF	OFF	OFF	ON	ON	ON	OFF	OFF
①	Blue	OFF	OFF	OFF	OFF	OFF	ON	ON	ON

Operation mode
 1→2→3→4→5→6→7→8 VALVE CLOSE
 8→7→6→5→4→3→2→1 VALVE OPEN

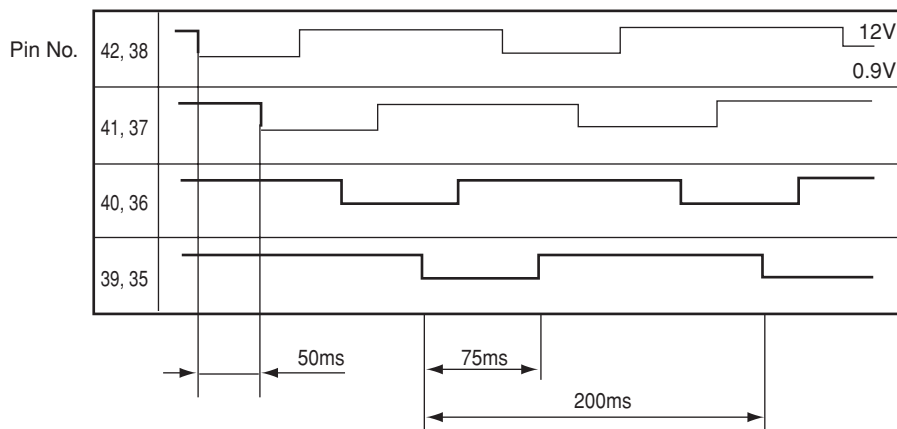

Fig. 11-2

With expansion valve control, opening degree is adjusted to stabilize target temperature, by detecting temperature of compressor head.

The period of control is about once per 20 seconds, and output a few pulses.

12. Power Factor Control Circuit

Power factor is controlled by almost 100%. (Effective use of power)

With IC in ACT module, control is performed so that input current waveform will be similar to waveform of input voltage.

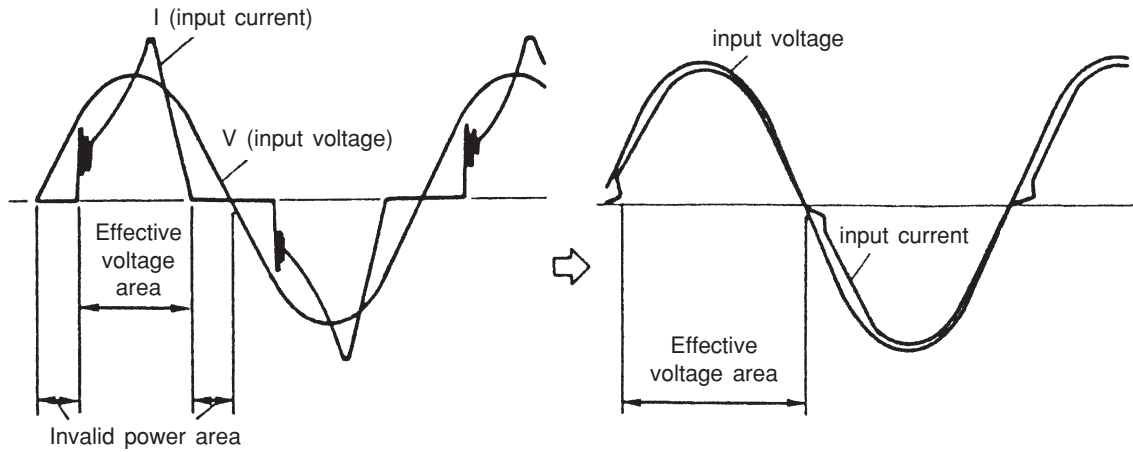

(Even if voltage is applied, current does not flow)

*Assuming the same current capacity (20A), power can be used about 10% effective, comparing with current use (power factor of 90%), and maximum capacity is thereby improved.

INSPECTING OUTDOOR ELECTRICAL PARTS

- Check to see that the LED is either on or blinking outdoor electrical unit 1 and electrical unit 2.
- Carry out inspections by examining the on/blinking status of LEDs 301-304.

LED number	LD301	LD302	LD303	LD304	Status	Checkpoints
Name	Diagnosis lamp 1	Diagnosis lamp 2	Communications lamp	Operation lamp		
Case 1	Off	Off	Off	Off	Normal off status or unconnected microcomputer power source	If the LED is not on even when the power source is connected the microcomputer power source is unconnected. → Inspection method 1
Case 2	Blinks once	Off	Off	Off	Microcomputer reset status (immediately after inserting power source or immediately after power source abnormally)	If is normal for LD301 to blink once after the power source has been inserted. If the unit stops when it is in operation and LD301 blinks once, it is possible that the power source has been temporarily interrupted by lightning or for some other reason. Replace the control PCB if this occurs frequently.
Case 3	Blinks	Off	Off	Off	Abnormally stop	Abnormally stop is shown by the number of times the LED blinks. → Inspection method 2
Case 4	On	Blinks	Off	Off	Thermistor abnormally	Thermistor abnormally is shown by the number of times the LED blinks. → Inspection method 3
Case 5	Off (blinks once)	Off	Blinks	Off (blinks)	Communications error	Communications error is shown by the number of times the LED blinks. → Inspection method 4 *In the case that an internal unit is not connected, the number of connected internal units is shown by the number of times the LED blinks. This is not a abnormally. The internal unit has no communications error and is able to operate normally.
Case 6	Off	Off	On	Off	Normal operation	Normal operation
Case 7	On	Off	On	Off	OVL1 operation	Normal operation
Case 8	Off	On	On	Off	OVL2 operation	Normal operation
Case 9	On	On	On	Off	OVL3 operation	Normal operation

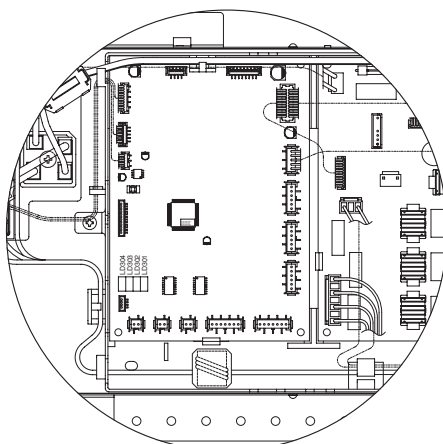

Inspection method 1

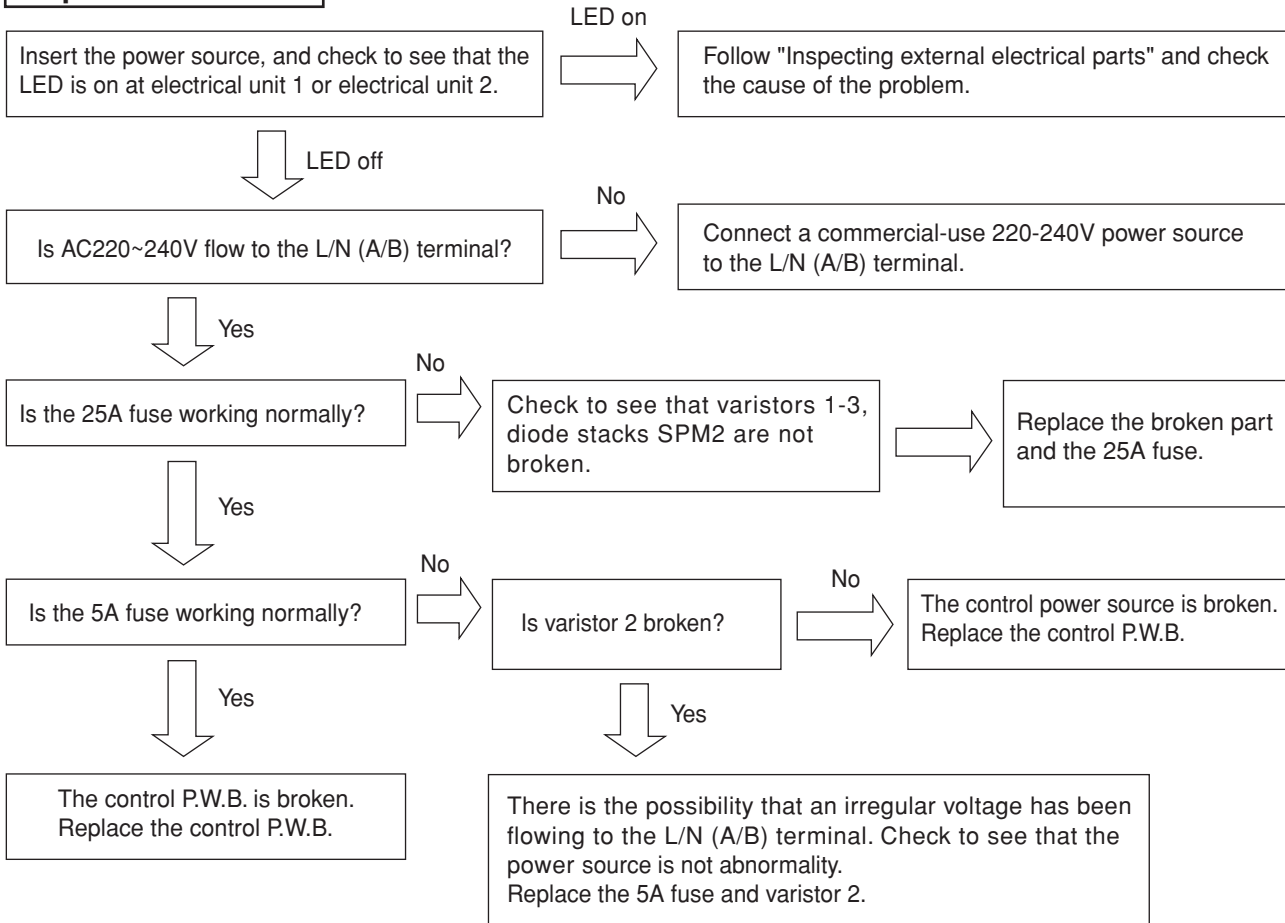

Inspection method 2

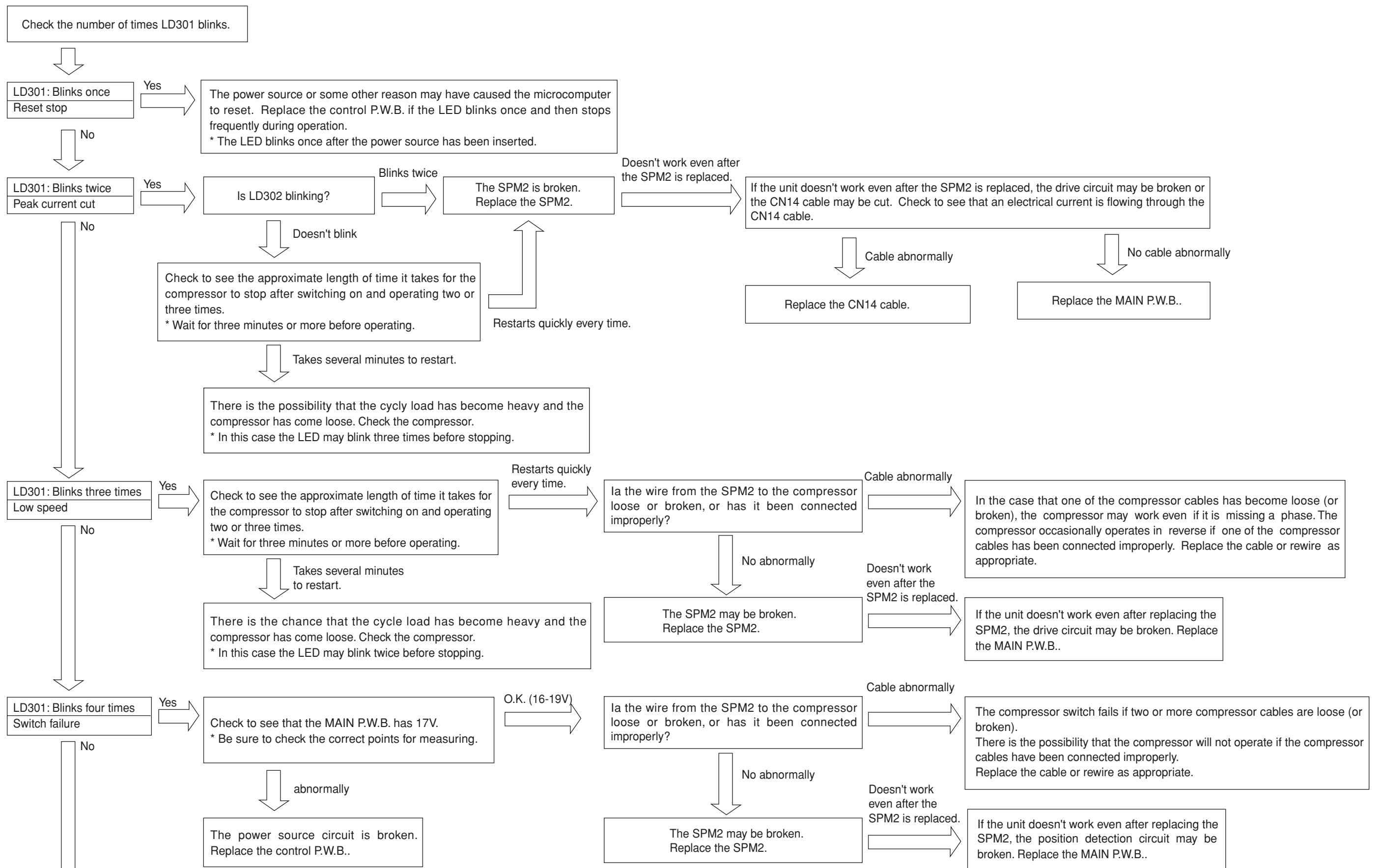

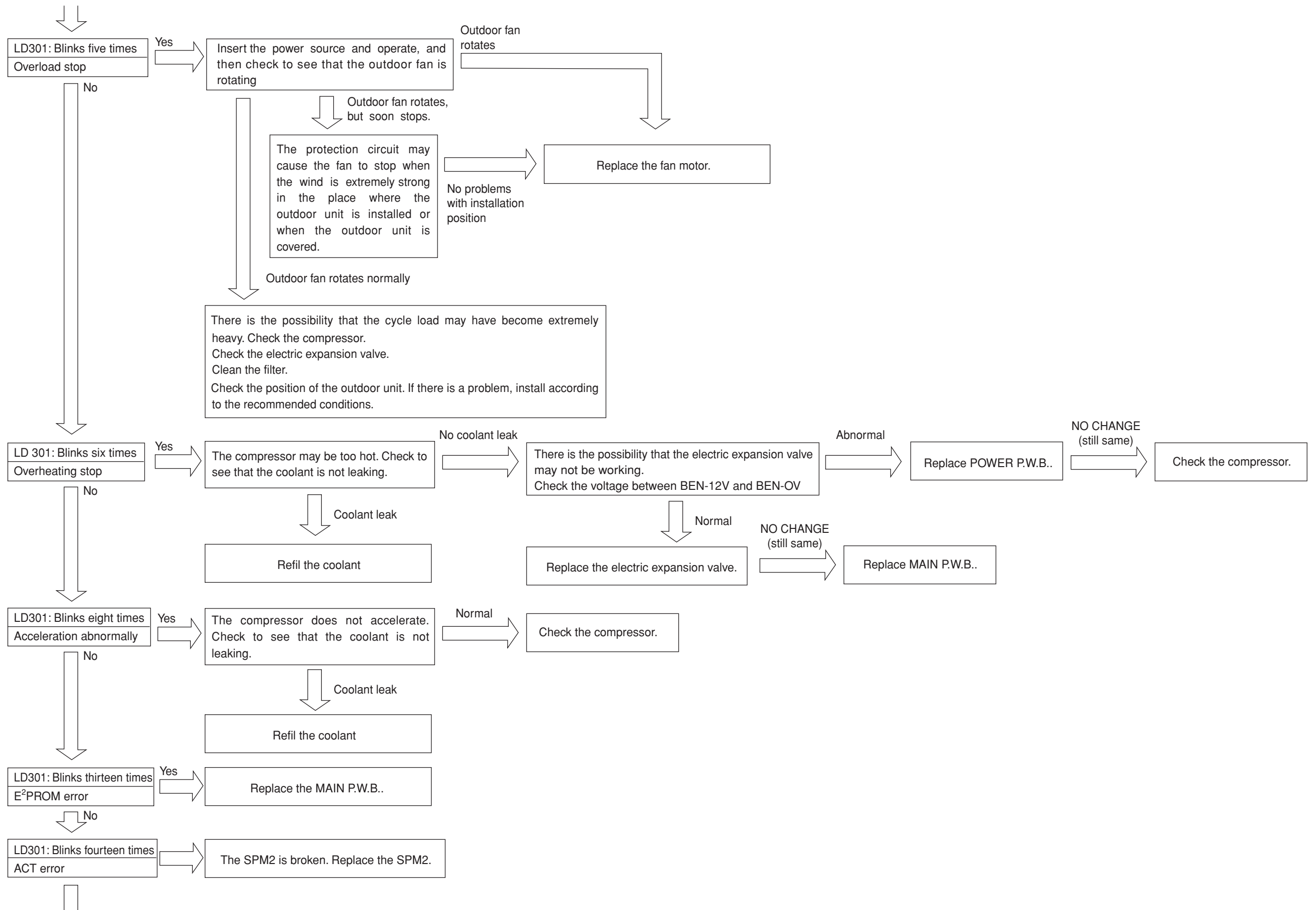

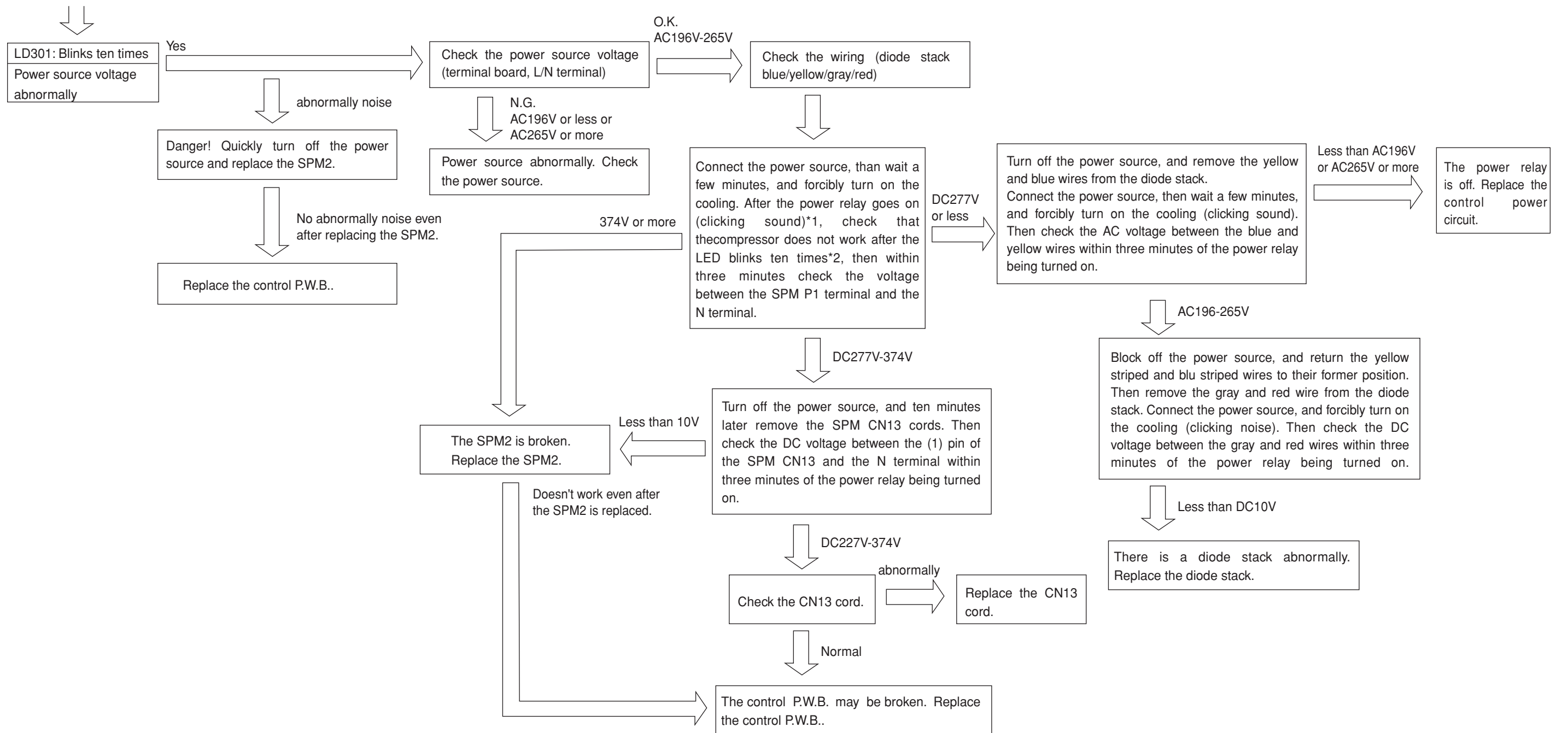

* 1 The power relay does not turn on without an operation order. In the case of a abnormally stop, the power relay turns off after approximately three minutes.

* 2 Carry out each of the voltage checks in the three minutes between the power relay turning on and turning off.

Inspection method 3

Check the light status of LD301 and LD302

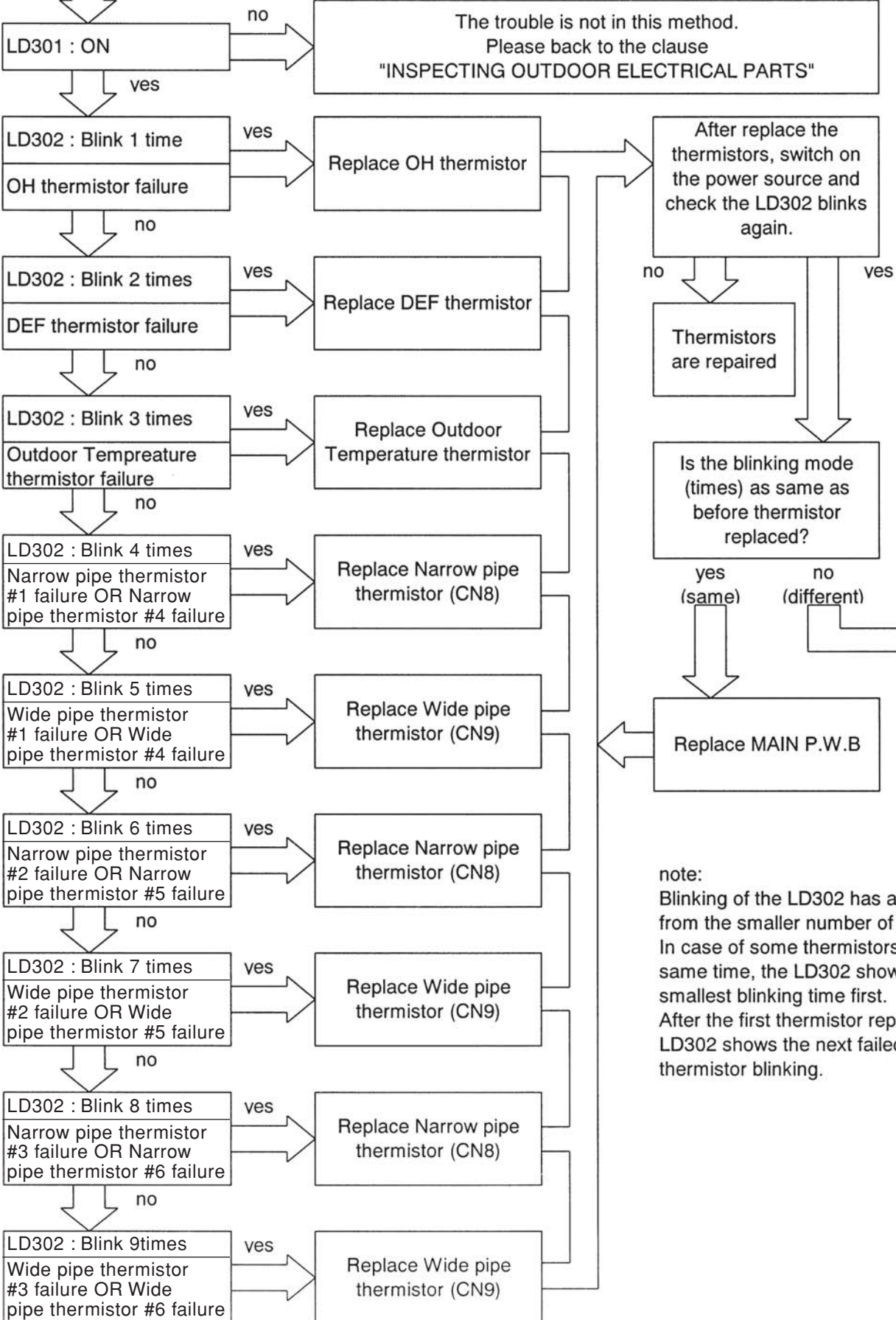

note:
 Blinking of the LD302 has a priority from the smaller number of times. In case of some thermistors are failed same time, the LD302 shows the smallest blinking time first. After the first thermistor repaired, LD302 shows the next failed thermistor blinking.

Inspection method 4

Check the light status of LD304

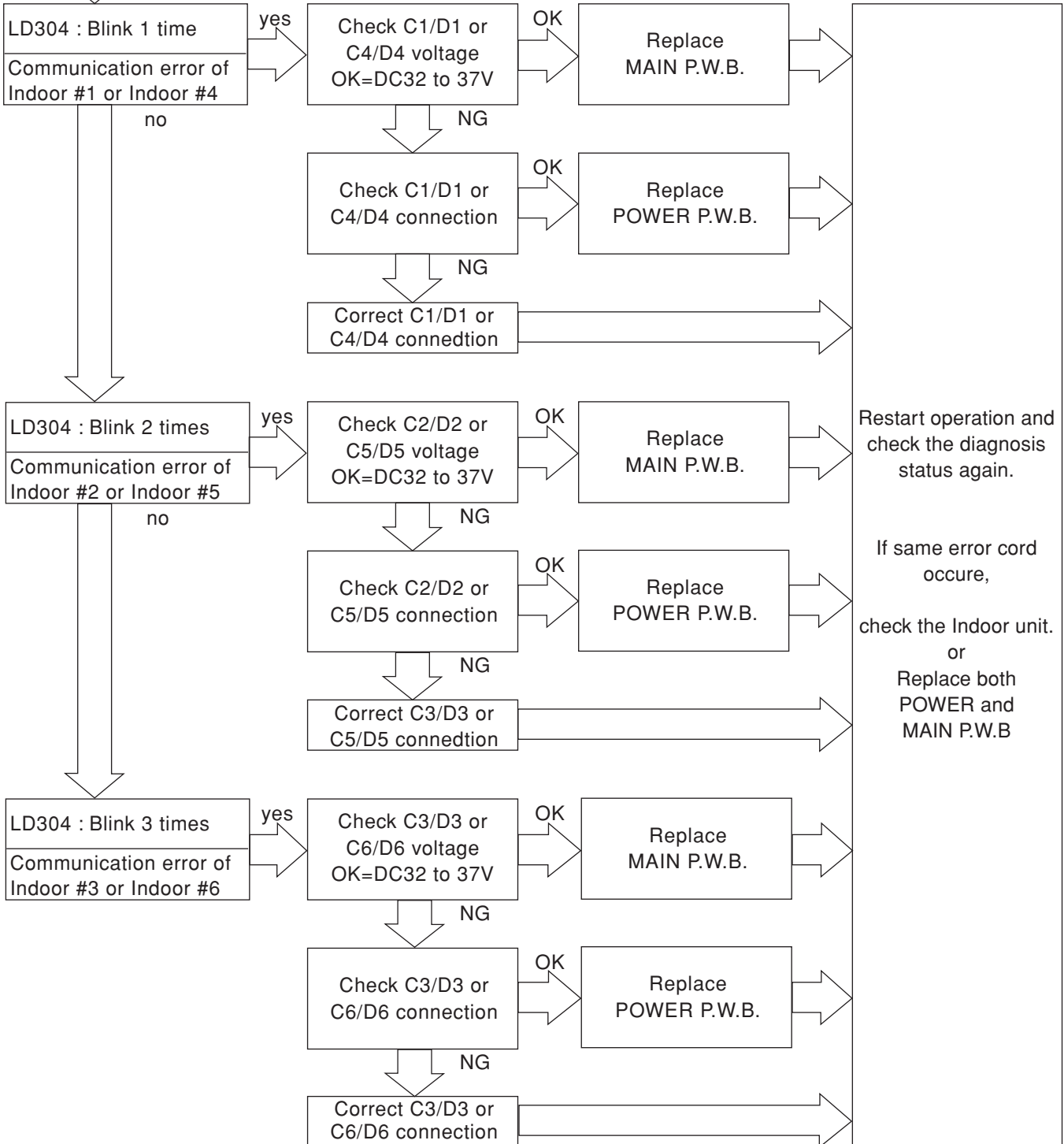

note:

If Indoor unit is not installed, the correspond error cord will be generated.

Blinking of the LD304 has a priority from the smaller number of times.

In case of some indoors are failed at same time, the LD304 shows the smallest blinking time first.

After the first failure repaired, LD304 shows the next fail.

HOW TO OPERATE USING THE SERVICE SWITCH THE OUTDOOR UNIT

1. Turn the Power switch off and then turn on again.
2. Remove the electrical parts cover.
3. Press the service switch for one second or more (wait for at least 30 seconds after turning the power source switch on).

Never operate the unit in this state for more than 5 minutes

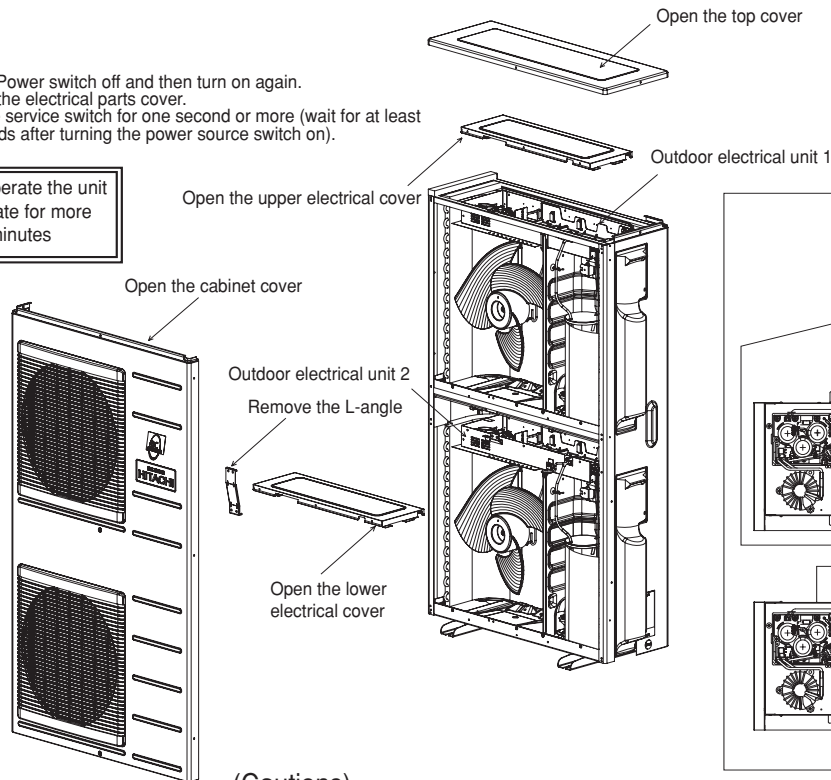

(Cautions)

- (1) If interface signal (35V DC) terminals C and D are not connected when the outdoor unit service switch is used for checking, the outdoor defects indicator (LD304) will blink to indicate communication error
- (2) If you do this with the compressor connector in a removed state, LD301 will blink four times, and the unit will not work.

Be sure to return the service switch to normal after checking with service operation is completed.

HOW TO OPERATE THE OUTDOOR UNIT INDEPENDENTLY

1. Connect the large dia. pipe side and small dia. pipe side service valves using a pipe.

Connect the small diameter service valve and the large diameter service valve using the reducing union and copper pipe as shown on the right.

Charge refrigerant of 300g after vacuuming (*1)

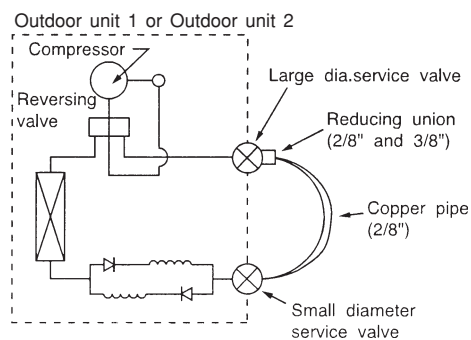

Parts to be prepared

- (1) Reducing union
2/8" (6.35mm)
3/8" (9.52mm)
- (2) Copper pipe (2/8" and 3/8")

Do not operate for 5 minutes or more

The operation method is the same as "How to operate using the connector to servicing the outdoor unit"

*1 The charging amount of 300g is equivalent to the load in normal operation.

TROUBLE SHOOTING

Model

PRECAUTIONS FOR CHECKING



1. Remember that the 0V line is biased to 162V in reference to the ground level.
2. Also note that it takes about 10 minutes until the voltage fall after the power switch is turned off.

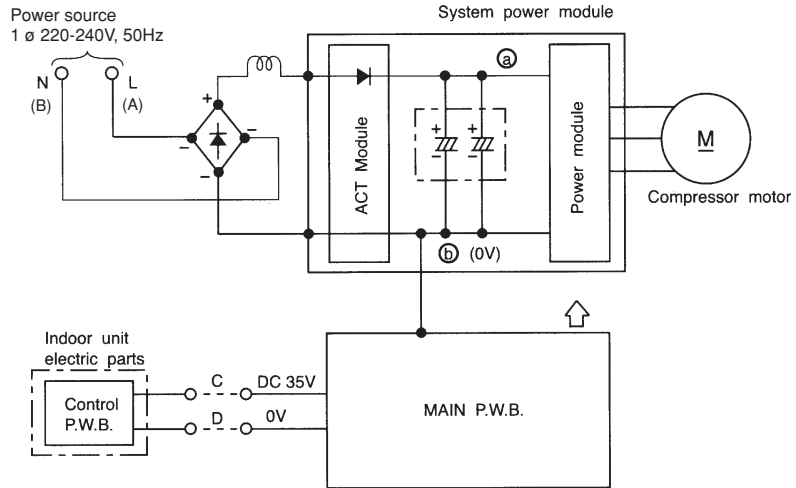

- Across (a) – (b) (0V line)..... approx 360V
- Across (a) – ground..... approx 155-170V
- Across (b) (0V line)– ground..... approx 155-170V



When using an oscilloscope, never ground it. Don't forget that high voltages as noted above may apply to the oscilloscope.

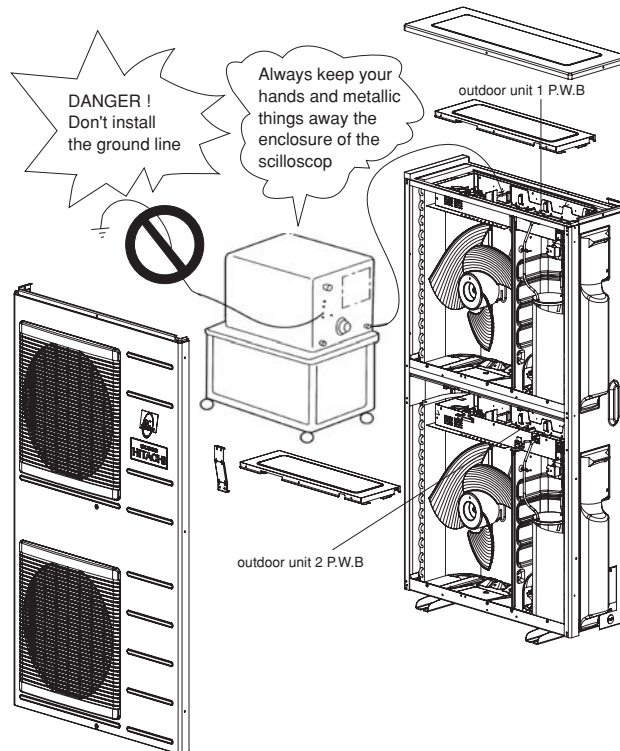

Discharge procedure and how to cut off power to power circuit



Caution

- Voltage of about 360V is charged at both ends of smoothing capacitor 330 μ F x 3.
- High voltage (DC 360V) is also charged at screw and terminal sections of system power module.
- During continuity check of each circuit of electrical parts in outdoor unit is performed, to prevent secondary trouble, disconnect red/gray wire connected to system power module (SPM) from diode stack. (Also be sure to perform discharging of smoothing capacitor.)

1. Disconnect power plug.
2. Wait for 10 minutes or more after power is turned off and then remove electrical parts box lid. As shown below. Apply soldering iron of 30-75W for 15 seconds or more to P1 and N1 black/white lead receptacles on system power module to discharge voltage from smoothing capacitor. Do not loosen or remove screws of system power module: If screw is loose, voltage will not be discharged.
3. Before operation check of each part of circuit, remove receptacle of red/gray lead connected to system power module from diode stack.

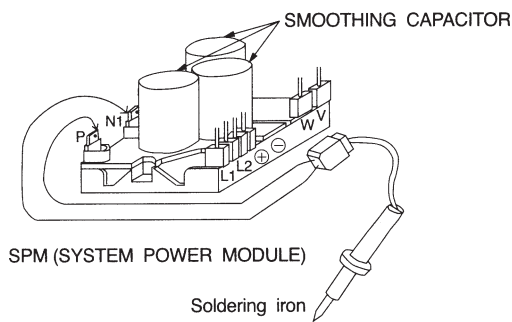

Do not use soldering iron with transformer: Doing so will blow thermal fuse inside transformer.

As shown left, apply soldering iron to metal parts (receptacles) in sleeve corresponding to P and N1 terminals of system power module.

Screws of system power module are live parts: Do not touch them. Screw tightening torque and method are strictly specified. When the screw is loosened or removed once, be sure to tighten according to the procedure shown on the right, with tightening torque of $0.8 \pm 0.2 \text{ N}\cdot\text{m}$.

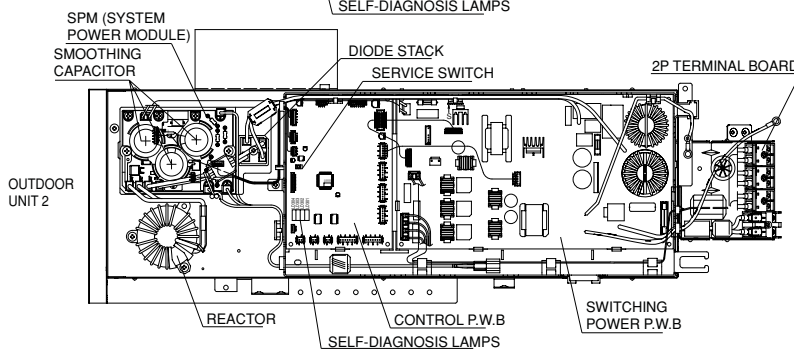
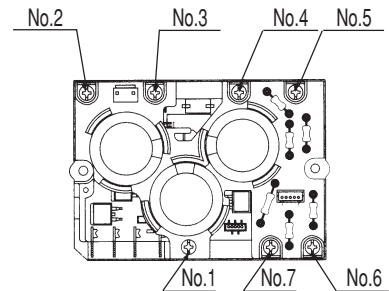
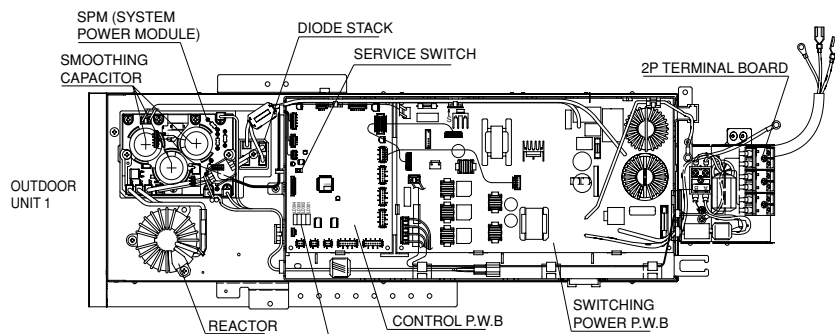

Lighting mode self-diagnosis lamp

RAM-130QH5

1 Location of self-diagnosis lamp

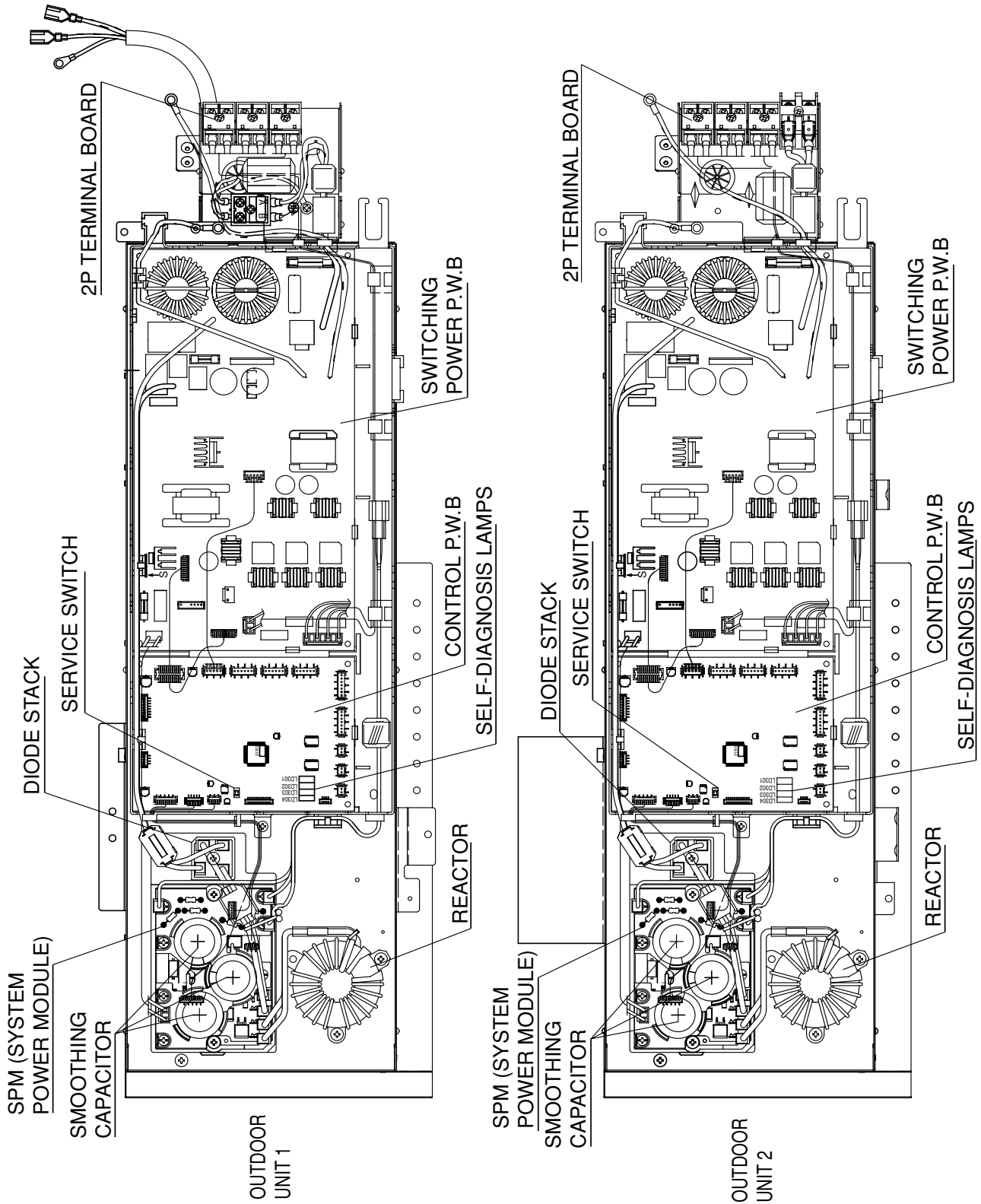

2 Lighting mode self-diagnosis lamp

RAM-130QH5

DANGER
(DC360V)

●WAIT FOR TEN-MINUTE (MIN) AFTER TURNING OFF THE POWER SWITCH WHEN SERVICE WORK IS BEING DONE.

SERVICE OPERATION

REFRIGERANT WITHDRAWAL OR SINGLE OPERATION OF THE OUTDOOR UNIT, SHALL SWITCH OFF THE EXCLUSIVE BREAKER FIRST. PUT THE SWITCH TO ON POSITION BACK AND WAIT AT LEAST 20 SECONDS. THEN PUSH THE SERVICE SWITCH WHICH IS ON THE CIRCUIT BOARD FOR MORE THAN 1 SECOND. (THERE WILL BE A COOLING CYCLE) TO PRESERVE PARTS FROM DAMAGE, MUST NOT OPERATE IT FOR MORE THAN 5 MINUTES. TO PAUSE, PUSH THE SERVICE SWITCH AT LEAST 1 SECOND IN CASE TO START OPERATING ONCE AGAIN PLEASE SWITCH OFF THE POWER BACK.

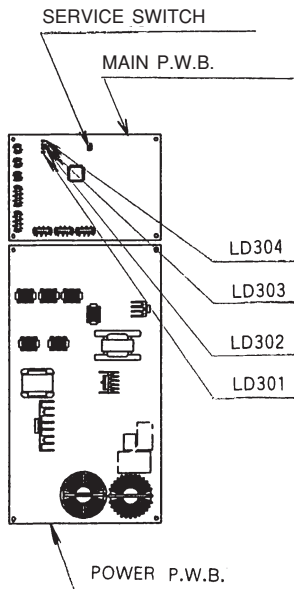

SELF-DIAGNOSIS LIGHTING MODE				■:LIT	▨:BLINKING	□:OFF
LD301	LD302	LD303	LD304	SELF-DIAGNOSIS NAME	DETAILS	MAIN CHECK POINT
[1] DURING OPERATION						
<input type="checkbox"/>	<input type="checkbox"/>	<input checked="" type="checkbox"/>	<input type="checkbox"/>	NORMAL OPERATION	COMPRESSOR OPERATION	NOT MALFUNCTION
<input checked="" type="checkbox"/>	<input type="checkbox"/>	<input type="checkbox"/>	<input type="checkbox"/>	OVERLOAD (1)	<p>THE ROTATION SPEED IS AUTOMATICALLY CONTROLLED TO PROTECT THE COMPRESSOR IN THE OVERLOAD CONDITION.</p>	THIS SHOWS AN OVERLOAD, NOT MALFUNCTION.
<input type="checkbox"/>	<input checked="" type="checkbox"/>	<input type="checkbox"/>	<input type="checkbox"/>	OVERLOAD (2)		
<input type="checkbox"/>	<input type="checkbox"/>	<input checked="" type="checkbox"/>	<input type="checkbox"/>	OVERLOAD (3)		
[2] DURING STOP						
<input type="checkbox"/>	<input type="checkbox"/>	<input type="checkbox"/>	<input type="checkbox"/>	NORMAL STOP	INDOOR THERMOSTAT OFF, MAIN OPERATION OFF.	NOT MALFUNCTION.
<input checked="" type="checkbox"/>	<input type="checkbox"/>	<input type="checkbox"/>	<input type="checkbox"/>	RESET STOP	WHEN STOPPED WITH POWER RESET. (NORMAL WHEN POWER HAS BEEN TURNED ON.)	P. W. B. s (POWER CIRCUIT, MICROCOMPUTER, ETC.)
<input checked="" type="checkbox"/>	<input type="checkbox"/>	<input type="checkbox"/>	<input type="checkbox"/>	1 TIME PEAK CURRENT CUT	OVERCURRENT IS DETECTED.	⊙COMPRESSOR ⊙P. W. B. s
<input checked="" type="checkbox"/>	<input type="checkbox"/>	<input type="checkbox"/>	<input type="checkbox"/>	2 TIMES		⊙SYSTEM POWER MODULE ⊙P. W. B. s
<input checked="" type="checkbox"/>	<input type="checkbox"/>	<input type="checkbox"/>	<input type="checkbox"/>	2 TIMES		
<input checked="" type="checkbox"/>	<input type="checkbox"/>	<input type="checkbox"/>	<input type="checkbox"/>	3 TIMES ABNORMAL LOW SPEED ROTATION	POSITION DETECTION SIGNAL IS NOT INPUT DURING OPERATION.	⊙SYSTEM POWER MODULE ⊙COMPRESSOR ⊙P. W. B. s
<input checked="" type="checkbox"/>	<input type="checkbox"/>	<input type="checkbox"/>	<input type="checkbox"/>	4 TIMES SWITCHING FAILURE	SWITCHING FROM LOW FREQUENCY SYNC START TO POSITION DETECTION OPERATION FAILURE.	⊙SYSTEM POWER MODULE ⊙COMPRESSOR ⊙P. W. B. s
<input checked="" type="checkbox"/>	<input type="checkbox"/>	<input type="checkbox"/>	<input type="checkbox"/>	5 TIMES OVERLOAD LOWER LIMIT CUT	UNDER THE LOWER LIMIT OF ROTATION SPEED WITH OVERLOAD CONTROL CIRCUIT OPERATED.	⊙OUTDOOR UNIT IS EXPOSED TO DIRECT SUNLIGHT OR ITS AIRFLOW BLOCKED. ⊙FAN MOTOR ⊙FAN MOTOR CIRCUIT ⊙THE VOLTAGE IS EXTREMELY LOW.
<input checked="" type="checkbox"/>	<input type="checkbox"/>	<input type="checkbox"/>	<input type="checkbox"/>	6 TIMES OH THERMISTOR TEMP. RISE	OH THERMISTOR OPERATED.	⊙LEAK OF REFRIGERANT ⊙COMPRESSOR ⊙OH THERMISTOR CIRCUIT ⊙FAN MOTOR ⊙FAN MOTOR CIRCUIT
<input checked="" type="checkbox"/>	<input type="checkbox"/>	<input type="checkbox"/>	<input type="checkbox"/>	8 TIMES ACCELERATION DEFECTIVE	NO ACCELERATION OVER THE LOWER LIMIT OF THE ROTATION SPEED.	⊙LEAK OF REFRIGERANT ⊙COMPRESSOR
<input checked="" type="checkbox"/>	<input type="checkbox"/>	<input type="checkbox"/>	<input type="checkbox"/>	10 TIMES ABNORMAL POWER VOLTAGE	POWER VOLTAGE IS ABNORMALLY LOW.	⊙POWER VOLTAGE ⊙CONNECTION OF REACTOR
<input checked="" type="checkbox"/>	<input type="checkbox"/>	<input type="checkbox"/>	<input type="checkbox"/>	12 TIMES FAN DEFECTIVE	OUTDOOR FAN ROTATION IS ABNORMAL.	⊙OUTDOOR FAN MOTOR ⊙P. W. B. s (FUSE)
<input checked="" type="checkbox"/>	<input type="checkbox"/>	<input type="checkbox"/>	<input type="checkbox"/>	13 TIMES EEPROM READ ERROR	MICROCOMPUTER CANNOT READ THE DATA IN EEPROM.	MAIN P. W. B.
<input checked="" type="checkbox"/>	<input type="checkbox"/>	<input type="checkbox"/>	<input type="checkbox"/>	14 TIMES ACTIVE CONVERTER DEFECTIVE	OVERVOLTAGE IS DETECTED BY SYSTEM POWER MODULE	SYSTEM POWER MODULE
<input checked="" type="checkbox"/>	<input checked="" type="checkbox"/>	<input type="checkbox"/>	<input type="checkbox"/>	LIT 1-9 TIMES THERMISTOR ABNORMAL	THERMISTOR IS OPEN OR SHORTED. *REFER TO THE FOLLOWING "CORRESPONDENCE TABLE FOR ABNORMAL THERMISTOR"	⊙THERMISTOR ⊙CONNECTION OF THERMISTOR DEFECTIVE ⊙THERMISTOR CIRCUIT
<input type="checkbox"/>	<input type="checkbox"/>	<input type="checkbox"/>	<input checked="" type="checkbox"/>	1 TIME COMMUNICATIONS ERROR BETWEEN INDOOR UNIT AND OUTDOOR UNIT	COMMUNICATION ERROR OF INDOOR 1	EVEN WHEN THE INDOOR UNIT IS NOT CONNECTED, IT BLINKS SIMILARLY. (NOT MALFUNCTION.)
<input type="checkbox"/>	<input type="checkbox"/>	<input type="checkbox"/>	<input checked="" type="checkbox"/>	2 TIMES	COMMUNICATION ERROR OF INDOOR 2	
<input type="checkbox"/>	<input type="checkbox"/>	<input type="checkbox"/>	<input checked="" type="checkbox"/>	3 TIMES	COMMUNICATION ERROR OF INDOOR 3	

*EXAMPLE OF BLINKING (5 TIMES) 2SEC LIGHTS FOR 0.25 SEC AT INTERVAL OF 0.25 SEC.

BLINKING TIMES	CORRESPONDENCE TABLE FOR ABNORMAL THERMISTOR
1 TIME	OVER HEAT THERMISTOR
2 TIMES	DEFROST THERMISTOR
3 TIMES	OUTDOOR THERMISTOR
4 TIMES	NARROW PIPE THERMISTOR (INDOOR 1 OR INDOOR 4)
5 TIMES	WIDE PIPE THERMISTOR (INDOOR 1 OR INDOOR 4)
6 TIMES	NARROW PIPE THERMISTOR (INDOOR 2 OR INDOOR 5)
7 TIMES	WIDE PIPE THERMISTOR (INDOOR 2 OR INDOOR 5)
8 TIMES	NARROW PIPE THERMISTOR (INDOOR 3 OR INDOOR 6)
9 TIMES	WIDE PIPE THERMISTOR (INDOOR 3 OR INDOOR 6)

TROUBLESHOOTING OF THE SYSTEM POWER MODULE

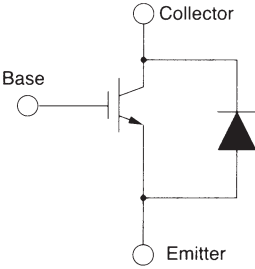
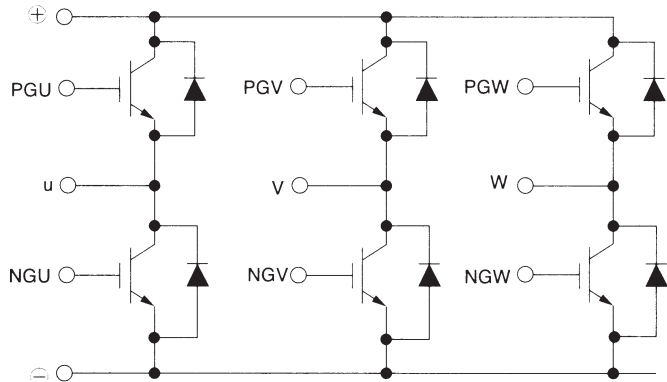
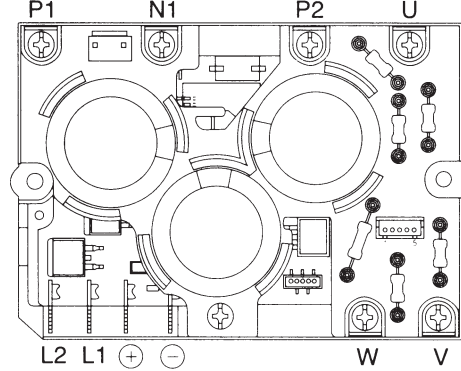
Type	GT15V31ISM
Element circuit	
Internal circuit of the module	
Terminal symbol of system module	 <p>※ See next page for values measured by tester</p> <p>※ Do not disassemble the system power module when troubleshooting is performed.</p>

HOW TO CHECK POWER MODULE

Checking power module using tester

Set tester to resistance range ($\times 100$)

If indicator does not swing in the following conductivity check, the power module is normal.

(In case of digital tester, since built-in battery is set in reverse direction, \oplus and \ominus terminals are reversed.)

CAUTION

If inner circuit of power module is disconnected (open), the indicator of tester will not swing and this may assumed as normal. In this case, if indicator swings when \oplus and \ominus terminals are connected in reverse of diagram below, it is normal. Furthermore, compare how indicator swings at U, V and W phases. If indicator swings the same way at each point, it is normal.

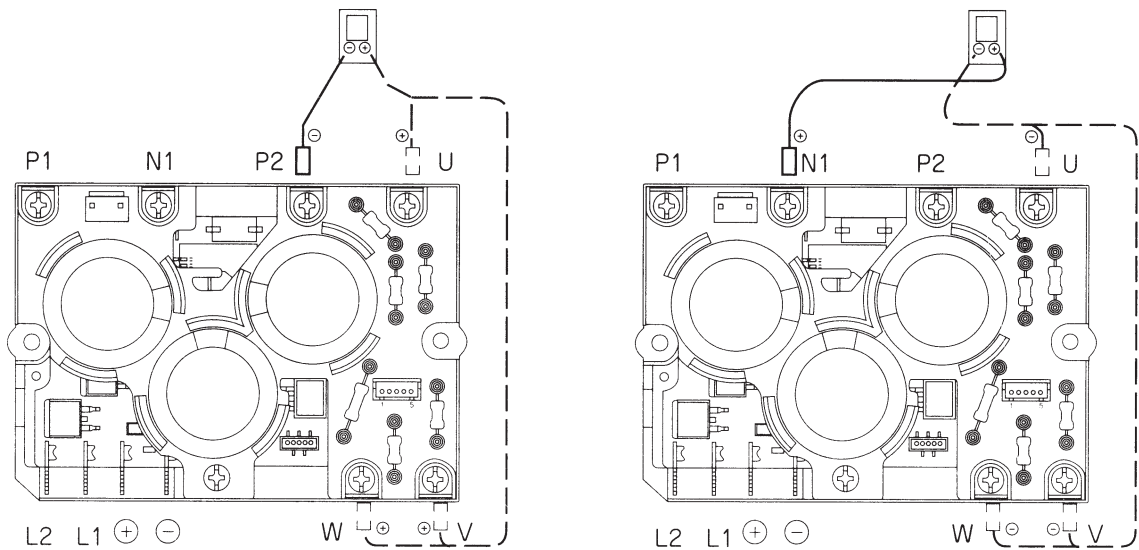

CHECKING THE REFRIGERATING CYCLE

(JUDGING BETWEEN GAS LEAKAGE AND COMPRESSOR DEFECTIVE)

Troubleshooting procedure (No operation, No heating, No cooling)

If the indoor pipe or service valve becomes frosted during heating of one unit, check the operation of Reversing valve.



Connect U.V.W phase leads to the power module again and operate the air conditioner.



Is the self-diagnosis lamp mode as shown on the right?

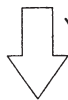

YES

Stop to operate and check the gas pressure in balancing mode.

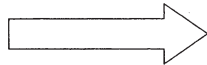

Outdoor air temperature (°C)	Charge port pressure	
	Mpa(G)	{kgf/cm ² (G)}
50	2.96	{30.14}
45	2.62	{26.72}
40	2.31	{23.58}
35	2.03	{20.73}
30	1.78	{18.14}
25	1.55	{15.79}
20	1.34	{13.66}
15	1.15	{11.74}
10	0.98	{10.02}
5	0.83	{8.48}
0	0.70	{7.10}
-5	0.58	{5.89}
-10	0.47	{4.81}

(R410A)

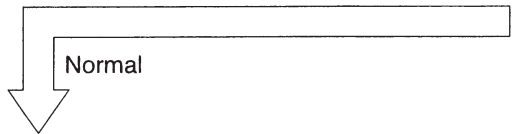
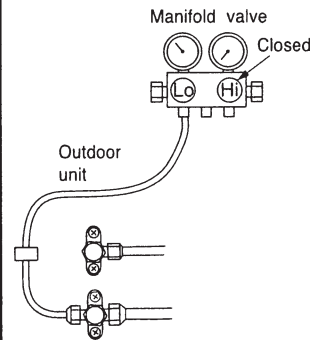

Checking the power module.

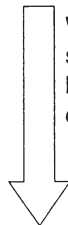

When the self-diagnosis lamp lights in the same condition as above.

The compressor is defective. Replace it and seal refrigerant.
 (If the compressor checker for an inverter type air conditioner is available, re-check using it.)

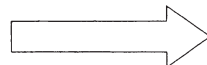

Abnormal Gas leaking

Gas leaks.
Repair and seal refrigerant.



Perform a final check of operation.

Lighting mode / Selfdiagnosis Lamp	Blinks 2 times	Blinks 3 times	Blinks 4 times	Blinks 5 times	Blinks 6 times	Blinks 8 times
LD301	Blinking	Blinking	Blinking	Blinking	Blinking	Blinking
LD302	Off	Off	Off	Off	Off	Off
Time until the lamp lights	2-3 seconds			Approx 10 seconds	Within approx 30 minutes	Approx 10 seconds
Possible malfunctioning part	Compressor				Gas leakage	Compressor

Blinking Off

DISASSEMBLY AND REASSEMBLY

MODEL RAM-130QH5

1. Electric parts

- (1) Remove the screw on both sides of upper cover, and then remove the upper cover.
- (2) Remove the screws holding the electric part cover, and then remove the cover.

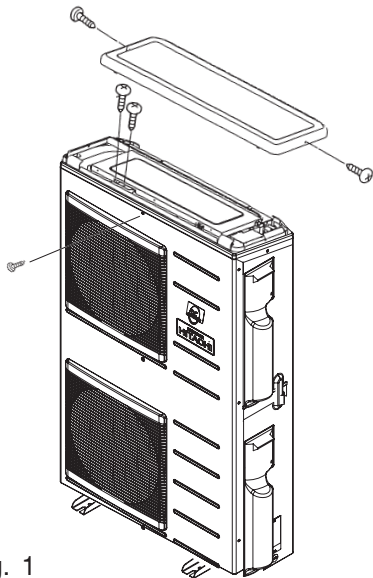

Fig. 1

- (3) Slightly widen the electric part cover to the left and right, and then lift the cover to remove it.

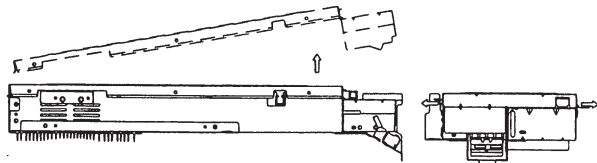

Fig. 2

- (4) Unplug the connectors of each lead wire and disconnect the ground wire from the P.W.B.; widen the tabs of supports at the front of P.W.B., and then lift the P.W.B. to remove it. (At this time, also remove 2P terminal board [LN terminal].)
- (5) Disconnect each lead wire from the system power module (SPM) assembly, and then remove the screws on left and right.

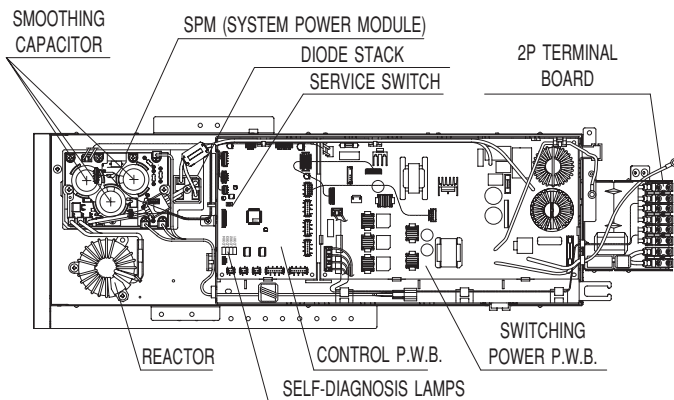

Fig. 3

- (6) When installing the electric part cover, fit the cover approximately horizontally so that it does not catch the terminal board or resin sleeve of cord.

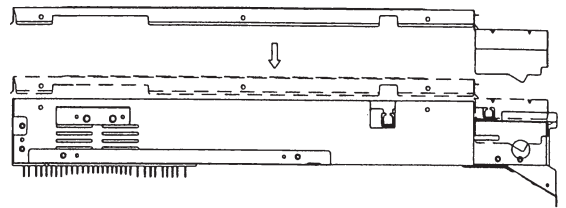

Fig. 4

2. Front cover

- (1) Remove the upper cover.
- (2) Remove the screw on right side.
- (3) Remove the screws from the bottom of front cover.
- (4) Remove the screws holding the front cover and electric parts.
- (5) Slightly open the right side, and lift the cover up to release it from the hook.

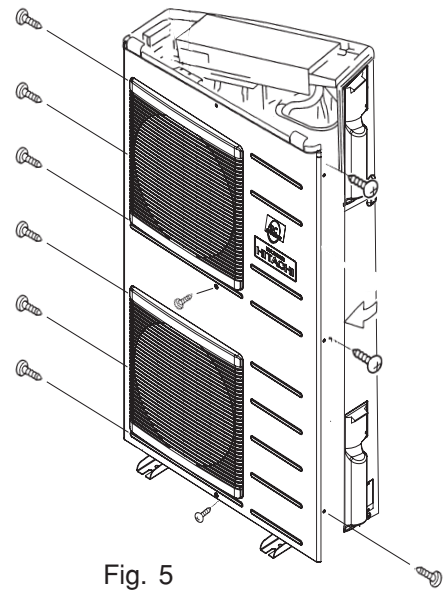

Fig. 5

<Repairing Refrigerating Cycle>

1. Electric expansion valve

and **Service valve assembly (with valve base)**

- (1) Remove the upper plate, side plate, front cover, both side covers and electric part box.
- (2) Remove the two screws holding the partition (one on base and one on top of condenser).
- (3) Remove the support that holds the lead wire, both of which are attached to the partition.
- (4) Pull the three Electric expansion valve coils up to remove them.
- (5) Use a pipe cutter, etc. to cut off the three pipes at the side of Electric expansion valve and condenser outlet pipe.
- (6) Remove the screws holding the valve base.
- (7) Lift the valve base to remove it from the base.

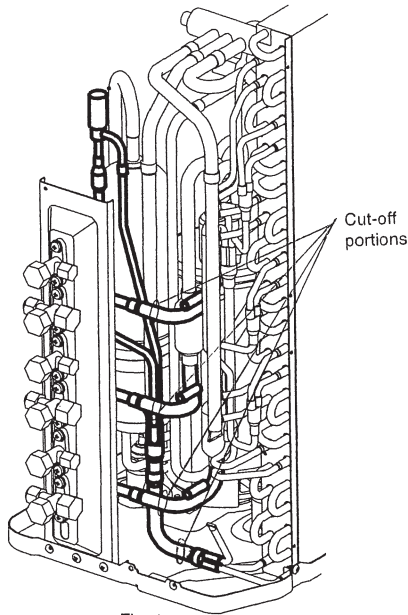

Fig. 1

2. Condenser

- (1) Remove the covers, electric part box, partition and supports (see steps (1)-(3) of item 1).
- (2) Remove the net at the back.
- (3) Cut off the condenser outlet pipe.
- (4) Cut off the condenser inlet pipe.
- (5) Remove the screws holding the condenser on both sides of base.

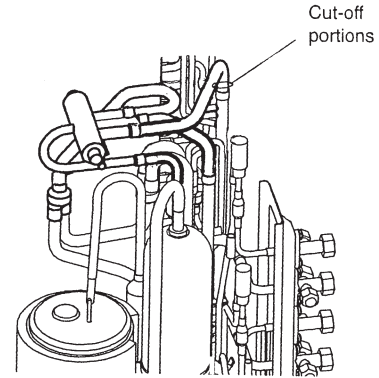

Fig. 2

3. Reversing valve

- (1) Remove the covers, electric part box, partition and supports (see steps (1)-(3) of item 1).
- (2) Remove the Reversing valve coil.
- (3) Cut off the three pipes at the side and bottom of Reversing valve.
- (4) Pull out the soldered portion of D-pipe.

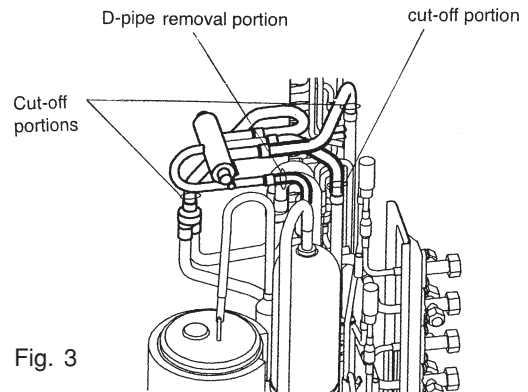
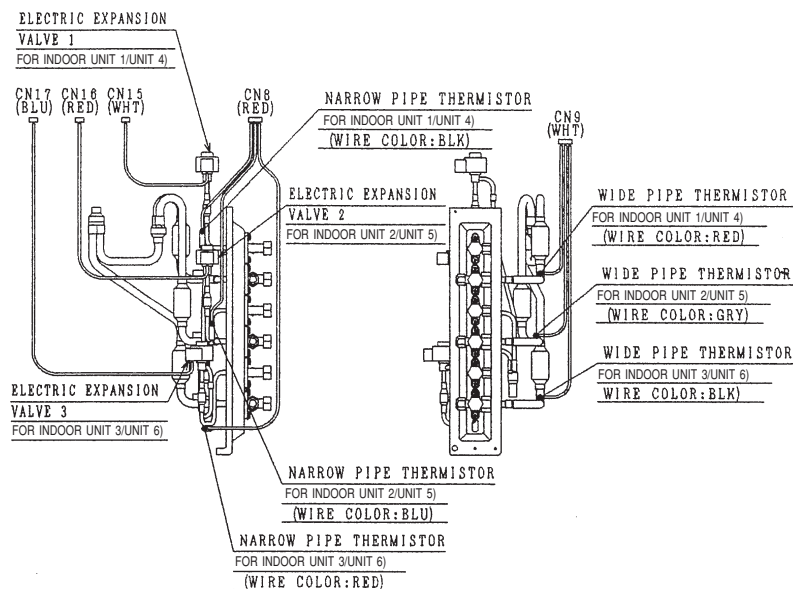

Fig. 3

ELECTRIC EXPANSION VALVE & PIPE THERMISTOR POSITION CHARTS

MODEL RAM-130QH5



PARTS LIST AND DIAGRAM

MODEL RAM-130QH5

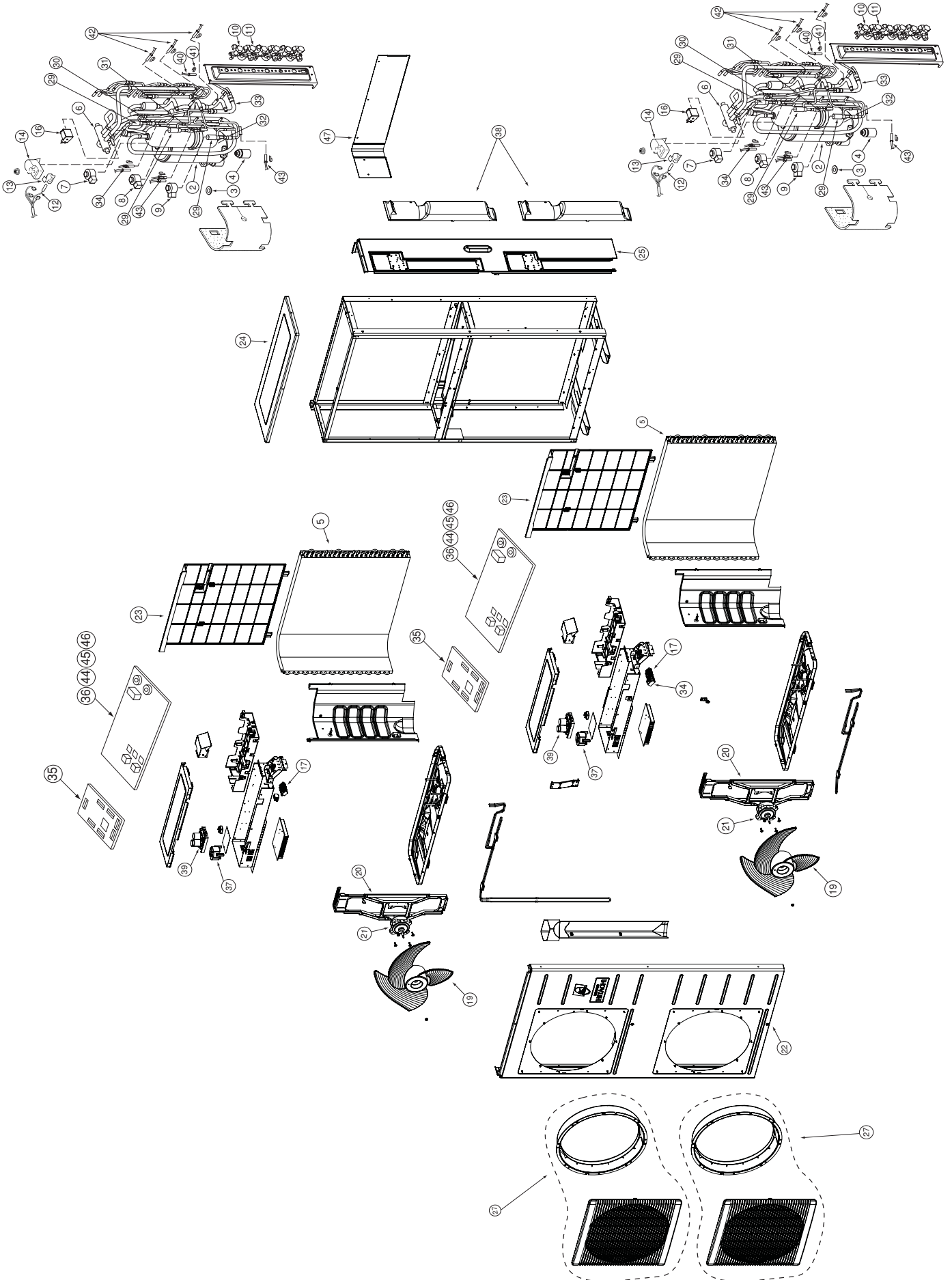

MODEL RAM-130QH5

NO.	PART NO.	Q'TY / UNIT	PARTS NAME
2	PMRAM-65QH4 S01	2	COMPRESSOR
3	KPNT1 001	6	PUSH NUT
4	RAC-2226HV 805	6	COMPRESSOR RUBBER
5	PMRAC-50NH4 S02	2	CONDENSER
6	PMRAC-50YHA1 905	2	REVERSING VALVE
7	PMRAM-65QH4 S04	2	EXPANSION VALVE COIL (W)
8	PMRAM-65QH4 S05	2	EXPANSION VALVE COIL (R)
9	PMRAM-65QH4 S06	2	EXPANSION VALVE COIL (B)
10	PMRAM-65QH4 S15	6	VALVE (2S)
11	PMRAM-65QH4 S16	6	VALVE (3S)
12	PMRAC-40CNH2 S14	2	THERMISTOR(OH)
13	PMRAC-25NH4 S09	2	THERMISTOR SUPPORT (OH)
14	PMRAC-25NH4 910	2	OLR COVER
16	PMRAM-22NHZ4 S02	2	MG-COIL (REVERSING VALVE)
17	PMRAM-90QH5 901	7	2P TERMINAL FOR C-D LINE
19	PMRAC-40CNH2 S17	2	PROPELLER FAN
20	PMRAC-40CNH2 S18	2	SUPPORT (FAN MOTOR)
21	PMRAC-40CNH2 S19	2	FAN MOTOR
22	PMRAM-130QH5 903	1	CABINET
23	PMRAM-130QH5 904	2	NET
24	PMRAM-130QH5 908	1	TOP COVER
25	PMRAM-130QH5 906	1	SIDE PLATE R
27	PMRAC-51CHA1 S07	2	D-GRILL-AS (INCL. MOUTH RING)
29	PMRAM-65QH4 S03	6	ELECTRICAL EXPANSION VALVE
30	PMRAM-65QH4 917	2	STRAINER (ST-PIPE-AS 1)
31	PMRAM-65QH4 918	2	STRAINER (ST-PIPE-AS 2)
32	PMRAM-130QH5 907	2	STRAINER (ST-PIPE-AS 3)
33	PMRAM-65QH4 920	2	STRAINER (CO-PIPE-AS 1)
34	PMRAC-18CVP2 S01	1	2P TERMINAL FOR L-N LINE
35	PMRAM-65QH5 S01	2	P.W.B. (MAIN)
36	PMRAM-130QH5 905	2	PWB (POWER)
37	PMRAC-18SH4 S01	2	REACTOR
38	PMRAM-65QH4 921	2	SV-COVER
39	PMRAC-40CNH2 S01	2	SYSTEM POWER MODULE (SPM2)
40	PMRAM-65QH4 S12	2	THERMISTOR (DEFROST)
41	PMRAM-65QH4 S07	2	THERMISTOR SUPPORT
42	PMRAM-65QH4 S13	2	THERMISTOR-V (W)
43	PMRAM-65QH4 S14	2	THERMISTOR-V (R)
44	PMRA-108CHLXA S08	1	VARISTOR (450NR)
45	PMRAC-40CNH2 S05	1	FUSE (2.5A)
46	PMRAM-55QH4 S08	1	FUSE (5A)
47	PMRAM-130QH5 909	1	MID COVER

HITACHI