

HITACHI

PM

NO. 0212E

RAI-25NH4/RAC-25NH4 RAI-40NH4/RAC-50NH4

SERVICE MANUAL

TECHNICAL INFORMATION

REFER TO THE FOUNDATION MANUAL

FOR SERVICE PERSONNEL ONLY

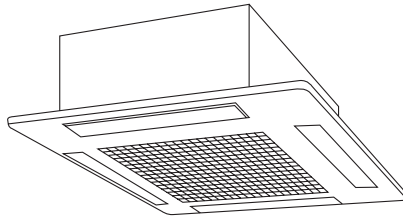

RAI-ECPM
RAI-25NH4
RAI-40NH4

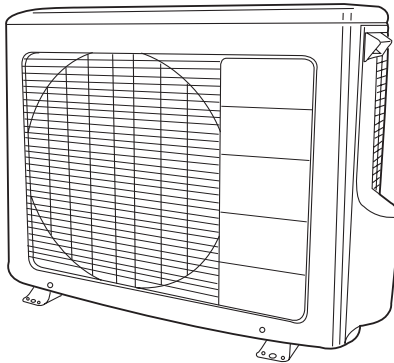

RAC-25NH4
RAC-50NH4



CONTENTS

SPECIFICATIONS	5
HOW TO USE	6
CONSTRUCTION AND DIMENSIONAL DIAGRAM	29
MAIN PARTS COMPONENT	31
WIRING DIAGRAM	33
CIRCUIT DIAGRAM	35
PRINTED WIRING BOARD LOCATION DIAGRAM	41
BLOCK DIAGRAM	43
BASIC MODE	45
REFRIGERATING CYCLE DIAGRAM	59
AUTO SWING FUNCTION	61
DESCRIPTION OF MAIN CIRCUIT OPERATION	62
SERVICE CALL Q & A	93
TROUBLE SHOOTING	96
PARTS LIST AND DIAGRAM	116

SPECIFICATIONS

TYPE		DC INVERTER (CEILING CASSETTE TYPE)			
		INDOOR UNIT	OUTDOOR UNIT	INDOOR UNIT	OUTDOOR UNIT
MODEL		RAI-25NH4	RAC-25NH4	RAI-40NH4	RAC-50NH4
POWER SOURCE		1 PHASE, 50 Hz, 220-240V		1 PHASE, 50 Hz, 220-240V	
COOLING	TOTAL INPUT (W)	695 (155~850)		1,380 (155~1,950)	
	TOTAL AMPERES (A)	3.20-2.93		6.35-5.81	
	CAPACITY	(kW)	2.50 (0.90 ~ 3.00)		4.00 (0.90 ~ 4.50)
(B.T.U./h)		8,540		13,660	
HEATING	TOTAL INPUT (W)	940 (155 ~ 1,050)		1,620 (155 ~ 1,900)	
	TOTAL AMPERES (A)	4.30-3.96		7.45-6.82	
	CAPACITY	(kW)	3.50 (0.90 ~ 5.00)		5.20 (0.90 ~ 5.80)
(B.T.U./h)		11,940		17,750	
DIMENSIONS (mm)	W	580	750	580	850
	H	285	570	285	650
	D	580	280	580	298
NET WEIGHT (kg)		20	38	20	60

SPECIFICATIONS AND PARTS ARE SUBJECT TO CHANGE FOR IMPROVEMENT

ROOM AIR CONDITIONER

INDOOR UNIT + OUTDOOR UNIT

JUNE 2004

Refrigeration & Air-Conditioning Division

SAFETY DURING REPAIR WORK

1. In order to disassemble and repair the unit in question, be sure to disconnect the power cord plug from the power outlet before starting the work.

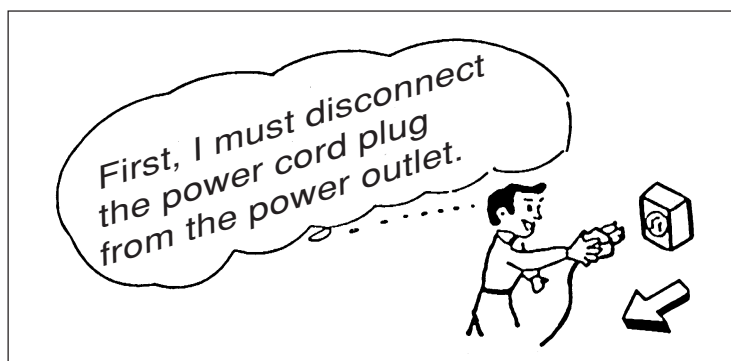

2. If it is necessary to replace any parts, they should be replaced with respective genuine parts for the unit, and the replacement must be effected in correct manner according to the instructions in the Service Manual of the unit.

If the contacts of electrical parts are defective, replace the electrical parts without trying to repair them.

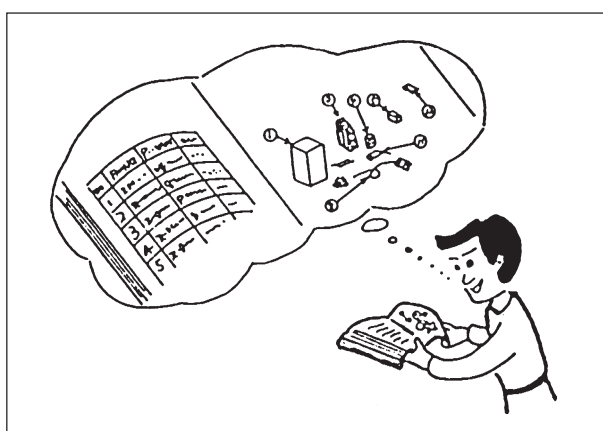

3. After completion of repairs, the initial state should be restored.
4. Lead wires should be connected and laid as in the initial state.
5. Modification of the unit by user himself should absolutely be prohibited.
6. Tools and measuring instruments for use in repairs or inspection should be accurately calibrated in advance.
7. In installing the unit having been repaired, be careful to prevent the occurrence of any accident such as electrical shock, leak of current, or bodily injury due to the drop of any part.
8. To check the insulation of the unit, measure the insulation resistance between the power cord plug and grounding terminal of the unit. The insulation resistance should be $1M\Omega$ or more as measured by a 500V DC megger.
9. The initial location of installation such as window, floor or the other should be checked for being and safe enough to support the repaired unit again. If it is found not so strong and safe, the unit should be installed at the initial location reinforced or at a new location.
10. Any inflammable thing should never be placed about the location of installation.
11. Check the grounding to see whether it is proper or not, and if it is found improper, connect the grounding terminal to the earth.



WORKING STANDARDS FOR PREVENTING BREAKAGE OF SEMICONDUCTORS

1. Scope

The standards provide for items to be generally observed in carrying and handling semiconductors in relative manufacturers during maintenance and handling thereof. (They apply the same to handling of abnormal goods such as rejected goods being returned).

2. Object parts

- (1) Micro computer
- (2) Integrated circuits (IC)
- (3) Field-effect transistors (FET)
- (4) P.C. boards or the like on which the parts mentioned in (1) and (2) of this paragraph are equipped.

3. Items to be observed in handling

- (1) Use a conductive container for carrying and storing of parts. (Even rejected goods should be handled in the same way).

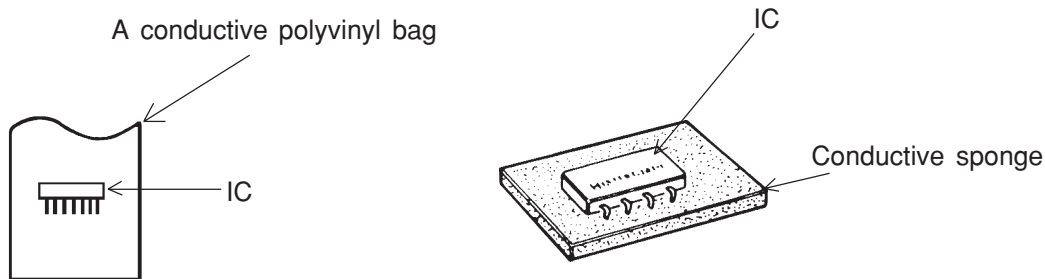

Fig. 1. Conductive Container

- (2) When any part is handled uncovered (in counting, packing and the like), the handling person must always use himself as a body earth. (Make yourself a body earth by passing one M ohm earth resistance through a ring or bracelet).
- (3) Be careful not to touch the parts with your clothing when you hold a part even if a body earth is being taken.
- (4) Be sure to place a part on a metal plate with grounding.
- (5) Be careful not to fail to turn off power when you repair the printed circuit board. At the same time, try to repair the printed circuit board on a grounded metal plate.

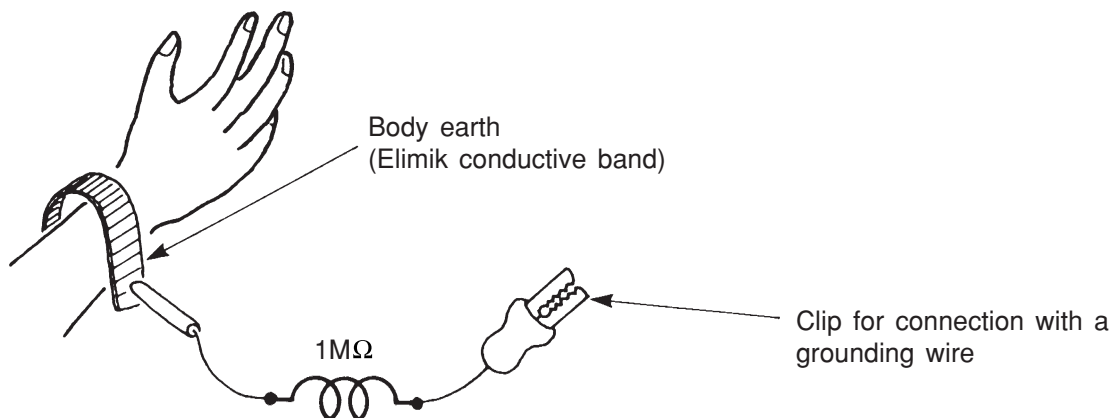

Fig. 2. Body Earth

(6) Use a three wire type soldering iron including a grounding wire.

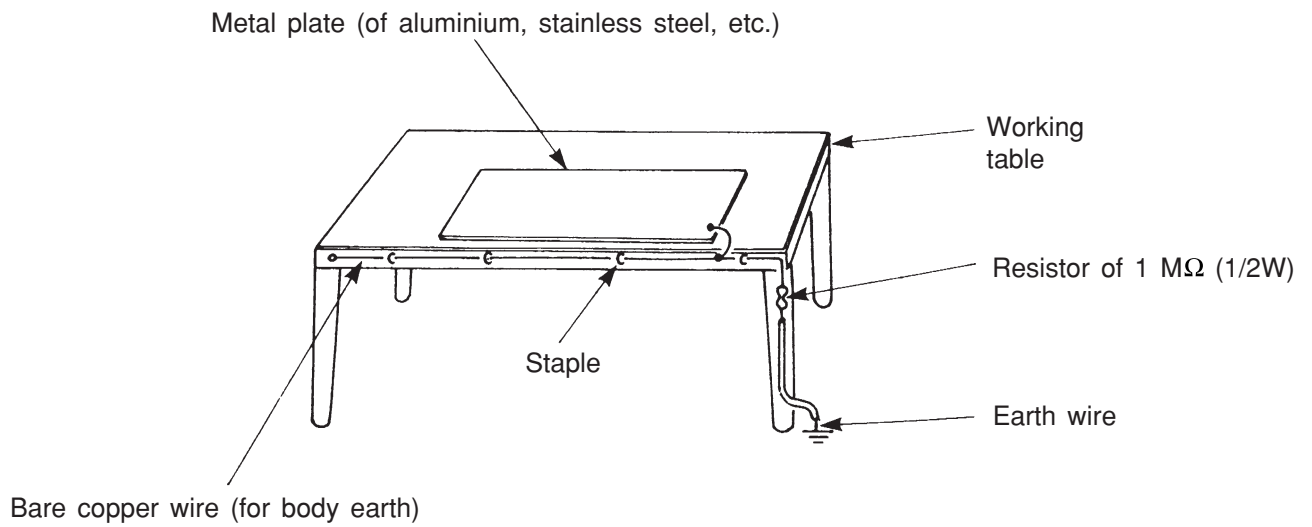

Fig. 3. Grounding of the working table

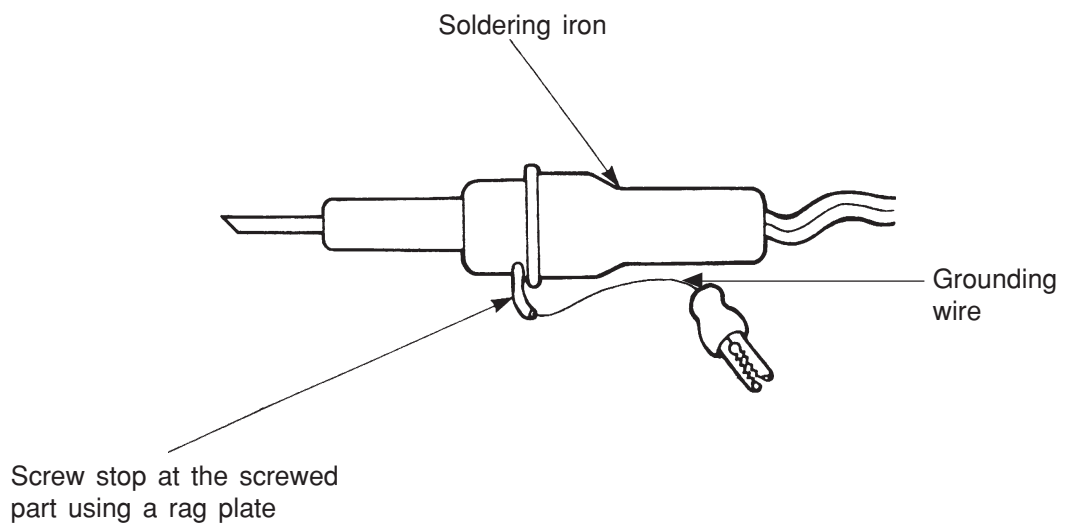

Fig. 4. Grounding a soldering iron

Use a high insulation mode (100V, 10MΩ or higher) when ordinary iron is to be used.

(7) In checking circuits for maintenance, inspection or some others, be careful not to have the test probes of the measuring instrument shortcircuit a load circuit or the like.

 **CAUTION**

1. In quiet operation or stopping the running, slight flowing noise of refrigerant in the refrigerating cycle is heard occasionally, but this noise is not abnormal for the operation.
2. When it thunders near by, it is recommend to stop the operation and to disconnect the power cord plug from the power outlet for safety.
3. The room air conditioner does not start automatically after recovery of the electric power failure for preventing fuse blowing. Re-press START/STOP button after 3 minutes from when unit stopped.
4. If the room air conditioner is stopped by adjusting thermostat, or missoperation, and re-start in a moment, there is occasion that the cooling and heating operation does not start for 3 minutes, it is not abnormal and this is the result of the operation of IC delay circuit. This IC delay circuit ensures that there is no danger of blowing fuse or damaging parts even if operation is restarted accidentally.
5. This room air conditioner should not be used at the cooling operation when the outside temperature is below 10°C (50°F).
6. This room air conditioner (the reverse cycle) should not be used when the outside temperature is below -15°C (5°F).
If the reverse cycle is used under this condition, the outside heat exchanger is frosted and efficiency falls.
7. When the outside heat exchanger is frosted, the frost is melted by operating the hot gas system, it is not trouble that at this time fan stops and the vapour may rise from the outside heat exchanger.

SPECIFICATIONS

MODEL		RAI-25NH4 RAI-40NH4	RAC-25NH4	RAC-50NH4
FAN MOTOR		25W	40 W	
FAN MOTOR CAPACITOR		NO	NO	
FAN MOTOR PROTECTOR		NO	NO	
COMPRESSOR		–	JU1012D	JU1013D
COMPRESSOR MOTOR CAPACITOR		NO	NO	
OVERLOAD PROTECTOR		NO	YES	
OVERHEAT PROTECTOR		NO	YES	
FUSE (for MICROPROCESSOR)		NO	3.0A	
POWER RELAY		NO	G4A	
POWER SWITCH		NO	NO	
TEMPORARY SWITCH		YES	NO	
SERVICE SWITCH		NO	YES	
TRANSFORMER		NO	NO	
VARISTOR		NO	450NR	
NOISE SUPPRESSOR		NO	YES	
THERMOSTAT		YES(IC)	YES(IC)	
REMOTE CONTROL SWITCH (LIQUID CRYSTAL)		YES	NO	
REFRIGERANT CHARGING VOLUME (Refrigerant 410A)	UNIT	-----	1150g	1400g
	PIPES (MAX. 20m)	WITHOUT REFRIGERANT BECAUSE COUPLING IS FLARE TYPE.		

Figure showing the Installation of Indoor and Outdoor unit.

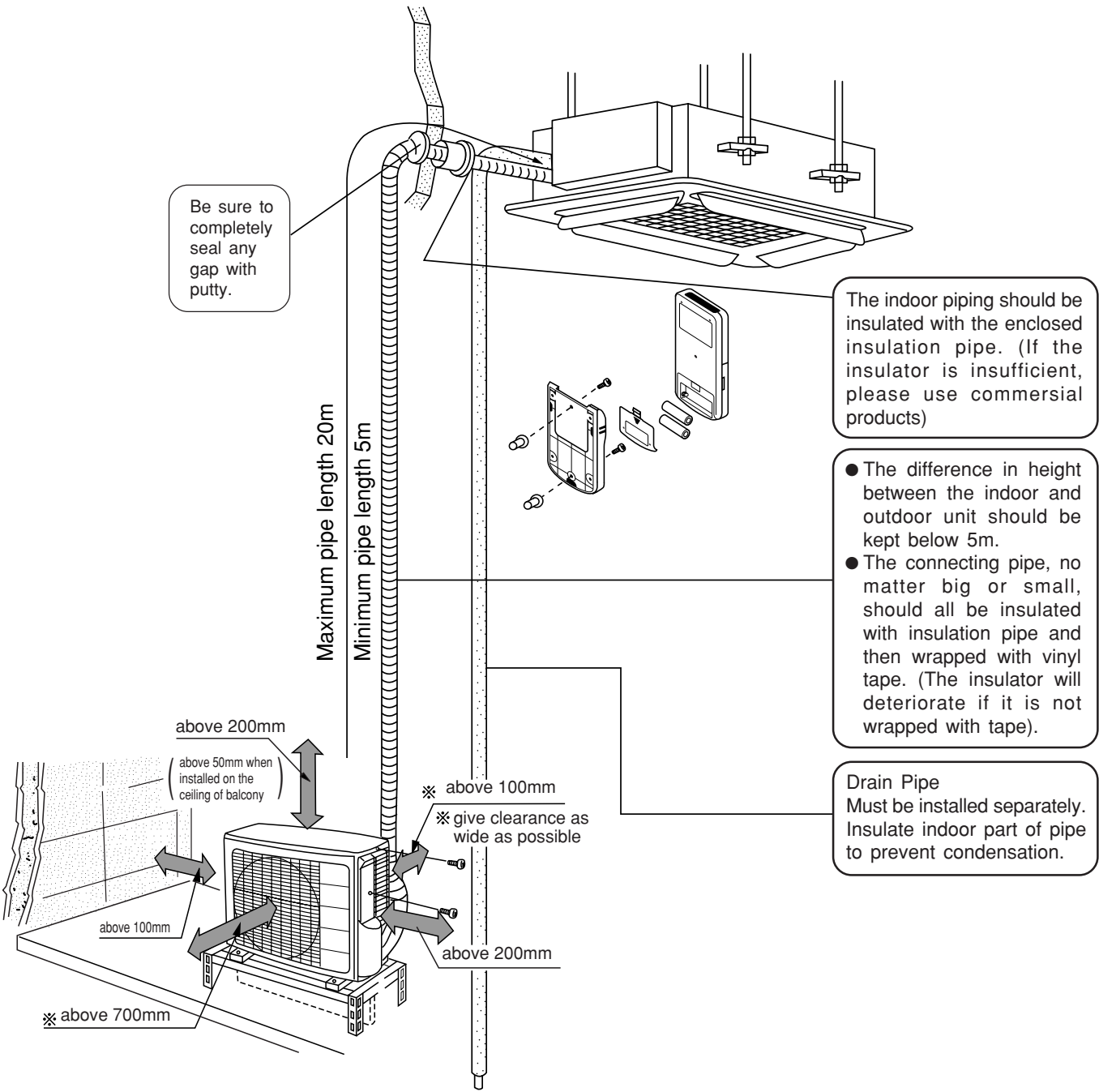

CAUTION  The installation height of indoor unit must be 2.3m or more.











SAFETY PRECAUTION



- Please read the “Safety Precaution” carefully before operating the unit to ensure correct usage of the unit.
- Pay special attention to signs of “**▲ Warning**” and “**▲ Caution**”. The “Warning” section contains matters which, if not observed strictly, may cause death or serious injury. The “Caution” section contains matters which may result in serious consequences if not observed properly. Please observe all instructions strictly to ensure safety.
- The sign indicate the following meanings.

 Make sure to connect earth line.	 The sign in the figure indicates prohibition.
 Indicates the instructions that must be followed.	

- Please keep this manual after reading.

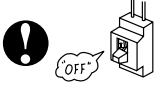
PRECAUTIONS DURING INSTALLATION	
 WARNING	<ul style="list-style-type: none"> ● Do not reconstruct the unit. Water leakage, fault, short circuit or fire may occur if you reconstruct the unit by yourself. 
	<ul style="list-style-type: none"> ● Please ask your sales agent or qualified technician for the installation of your unit. Water leakage, short circuit or fire may occur if you install the unit by yourself.
 CAUTION	<ul style="list-style-type: none"> ● Please use earth line. Do not place the earth line near water or gas pipes, lightning-conductor, or the earth line of telephone. Improper installation of earth line may cause electric shock. 
	<ul style="list-style-type: none"> ● A circuit breaker should be installed depending on the mounting site of the unit. Without a circuit breaker, the danger of electric shock exists.
	<ul style="list-style-type: none"> ● Do not install near location where there is flammable gas. The outdoor unit may catch fire if flammable gas leaks around it. ● Please ensure smooth flow of water when installing the drain hose. 

PRECAUTIONS DURING SHIFTING OR MAINTENANCE	
 W A R N I N G	<ul style="list-style-type: none"> ● Should abnormal situation arises (like burning smell), please stop operating the unit and turn off the circuit breaker. Contact your agent. Fault, short circuit or fire may occur if you continue to operate the unit under abnormal situation. 
	<ul style="list-style-type: none"> ● Please contact your agent for maintenance. Improper self maintenance may cause electric shock and fire.
	<ul style="list-style-type: none"> ● Please contact your agent if you need to remove and reinstall the unit. Electric shock or fire may occur if you remove and reinstall the unit yourself improperly.

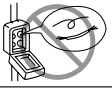
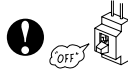
PRECAUTIONS DURING OPERATION	
 W A R N I N G	<ul style="list-style-type: none"> ● Avoid an extended period of direct air flow for your health. 
	<ul style="list-style-type: none"> ● Do not insert a finger, a rod or other objects into the air outlet or inlet. As the fan is rotating at a high speed, it will cause injury. Before cleaning, be sure to stop the operation and turn the breaker OFF. 
	<ul style="list-style-type: none"> ● Do not use any conductor as fuse wire, this could cause fatal accident. 
	<ul style="list-style-type: none"> ● During thunder storm, disconnect and turn off the circuit breaker. 

PRECAUTIONS DURING OPERATION

- The product shall be operated under the manufacturer specification and not for any other intended use.



- Do not attempt to operate the unit with wet hands, this could cause fatal accident.

- When operating the unit with burning equipments, regularly ventilate the room to avoid oxygen insufficiency.

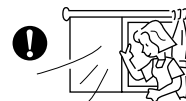

- Do not direct the cool air coming out from the air-conditioner panel to face household heating apparatus as this may affect the working of apparatus such as the electric kettle, oven etc.

- Please ensure that outdoor mounting frame is always stable, firm and without defect. If not, the outdoor unit may collapse and cause danger.

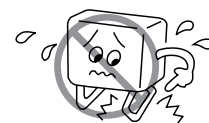

C
A
U
T
I
O
N



- Do not splash or direct water to the body of the unit when cleaning it as this may cause short circuit.

- Do not use any aerosol or hair sprays near the indoor unit. This chemical can adhere on heat exchanger fin and blocked the evaporation water flow to drain pan. The water will drop on tangential fan and cause water splashing out from indoor unit.



- Please switch off the unit and turn off the circuit breaker during cleaning, the high-speed fan inside the unit may cause danger.

- Turn off the circuit breaker if the unit is not to be operated for a long period.



- Do not climb on the outdoor unit or put objects on it.

- When operating the unit with the door and windows opened, (the room humidity is always above 80%) and with the air deflector facing down or moving automatically for a long period of time, water will condense on the air deflector and drips down occasionally. This will wet your furniture. Therefore, do not operate under such condition for a long time.
- If the amount of heat in the room is above the cooling or heating capability of the unit (for example: more people entering the room, using heating equipments and etc.), the preset room temperature cannot be achieved.

NAMES AND FUNCTIONS OF EACH PART

INDOOR UNIT

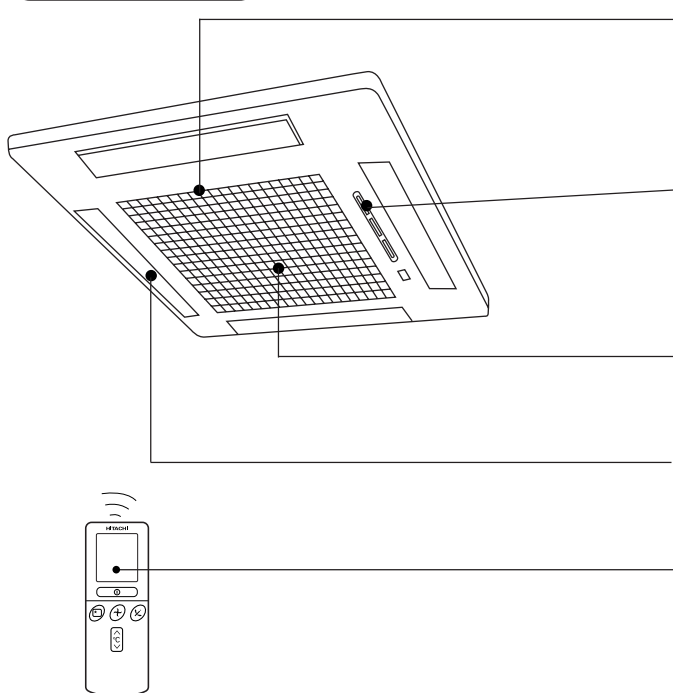

AIR FILTER

To prevent dust from coming into the indoor unit.
(Refer page 19)

INDOOR UNIT INDICATORS

Light indicator showing the operating condition.
(Refer page 5)

SUCTION GRILL (AIR INLET)

HORIZONTAL DEFLECTOR (AIR OUTLET)

(Refer page 15)

REMOTE CONTROL

Send out operation signal to the indoor unit. So as to operate the whole unit.
(Refer page 6)

MODEL NAME AND DIMENSIONS

MODEL	WIDTH (mm)	HEIGHT (mm)	DEPTH (mm)
RAI-25NH4 / RAI-40NH4	580	285	580

MULTI-AIR CONDITIONER

With this multi-air conditioner, several indoor units can be connected to one outdoor unit to be driven. You can operate the required number of indoor units.

Combination of operations:

When operation mode is selected:

- You cannot operate the indoor units in the following combinations.

One unit	Other unit
Heating	Cooling
	Dehumidifying
	Circulating (fan)

- The indoor unit which is switched on first continues to operate, but other indoor units which is switched on later does not operate while the lamp lights.
- To restart an indoor unit which was operated later, stop the indoor unit which was operated first or later and reset the type of operation, then perform operation again.

During automatic operation:

- When heating operation is automatically selected for the first indoor unit, the next indoor unit will then start to heat. Also, if cooling or dehumidifying is automatically selected for the first indoor unit, the next indoor unit will also start to cool or dehumidify.

Adjusting the number of indoor units:

Decrease the number of indoor units to be operated especially when it is very hot or very cold or when you want to reach the preset temperature quickly.

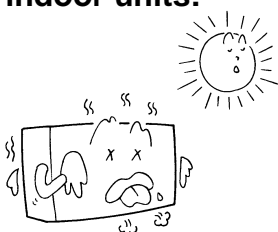

Stopped indoor units:

When an indoor unit is operated in the cooling, heating or dehumidifying mode in one room, the sound of refrigerant flow may be heard from a stopped indoor unit or a stopped indoor unit may become warm. This is because the indoor unit returns refrigerant to the outdoor unit to be ready for operation.

OPERATION INDICATOR

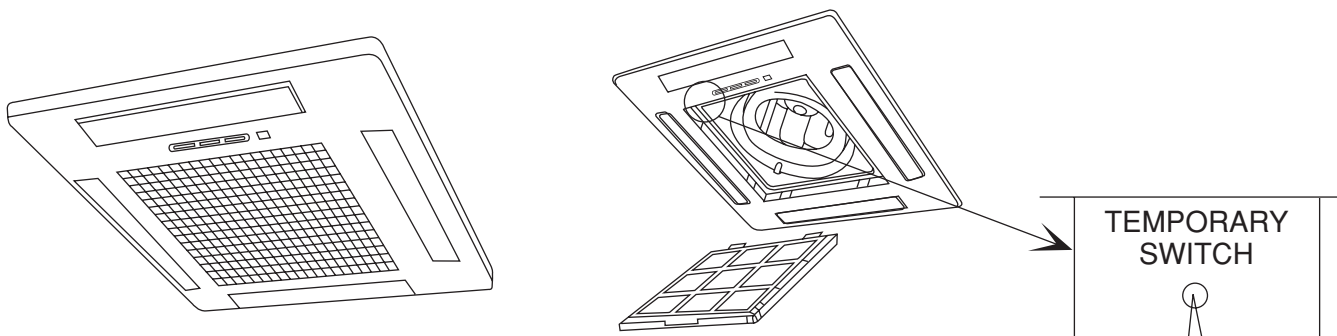

TEMPORARY SWITCH

Use this switch to start and stop when the remote controller does not work.
 [Use non-conductor stick (example toothpick)]

- By pressing the temporary switch, the operation is done in previously set operation mode.
- When the operation is done using the temporary switch after the power source is turned off and turn on again, the operation will be done in automatic mode.

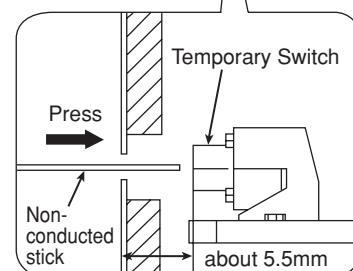

INDOOR UNIT INDICATORS

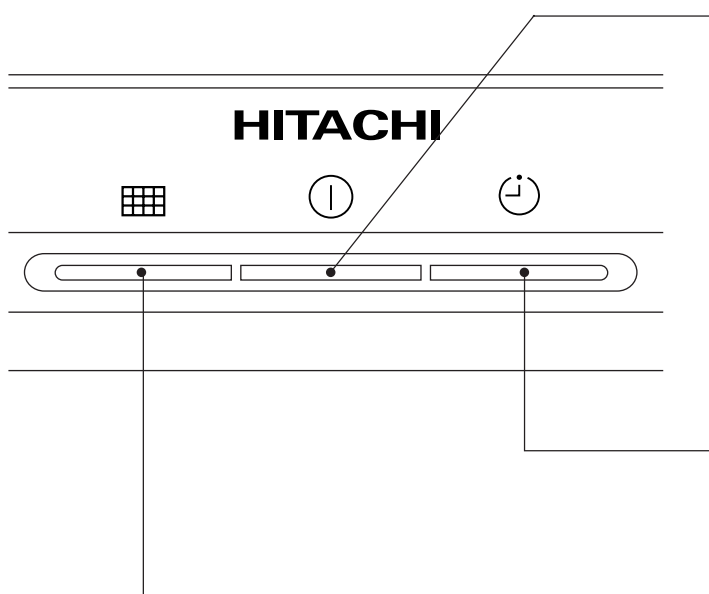

OPERATION LAMP

This lamp lights during operation.
 The OPERATION LAMP flashes in the following cases during heating.

- (1) **During preheating**
 For about 2–3 minutes after starting up.
- (2) **During defrosting**
 Defrosting will be performed about once an hour when frost forms on the heat exchanger of the outdoor unit, for 5–10 minutes each time.

TIMER LAMP

This lamp lights when the timer is working.

FILTER LAMP

When the device is operated for a total of about 200 hours, the FILTER lamp lights to indicate that it is time to clean the filter. The lamp goes out when the “ (AUTO SWING)” button is pressed while the device is on “STANDBY MODE”.

NAMES AND FUNCTIONS OF REMOTE CONTROL UNIT

REMOTE CONTROLLER

- Operate by pointing towards the signal receptor on the indoor unit. The range of control is about 7 meters. Signal receivable angle range is approximately 70°. However, if there is an electronic light sensor device (inverter) in the room, signal may not be received or receivable distance may become shorter.
- Indoor unit must be install 1 meter or more away from lighting.
- Handle the remote controller with care. Dropping it or getting it wet may compromise its signal transmission capability.
- After new batteries are inserted into the remote controller, the unit will initially require approximately 10 seconds to respond to commands and operate.

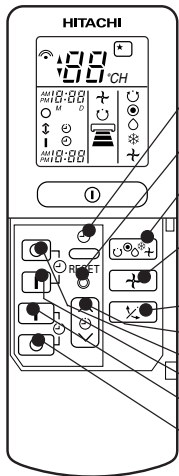
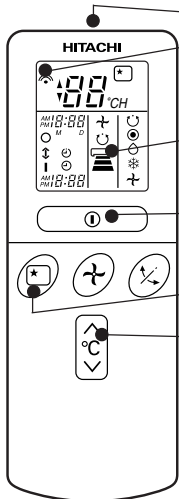
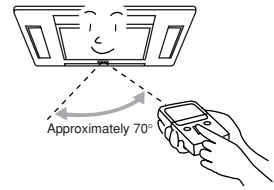

- **Signal emitting window/transmission sign**
Point this window toward the indoor unit when controlling it. The transmission sign blinks when a signal is sent.
- **Display**
This indicates the room temperature selected, current time, timer status, function and intensity of circulation selected.
- **START/STOP button**
Press this button to start operation. Press it again to stop operation.
- **SLEEP button**
Use this button to set the sleep timer.
- **TEMPERATURE buttons**
Use these buttons to raise or lower the temperature setting. (Keep pressed, and the value will change more quickly.)
- **TIME button**
Use this button to set and check the time and date.
- **RESET buttons**
- **FUNCTION selector**
Use this button to select the operating mode. Every time you press it, the mode will change from (AUTO) to (HEAT) to (DEHUMIDIFY) to (COOL) and to (FAN) cyclically.
- **FAN SPEED selector**
This determines the fan speed. Every time you press this button, the intensity of circulation will change from (AUTO) to (HI) to (MED) to (LOW) (This button allows selecting the optimal or preferred fan speed for each operation mode).
- **AUTO SWING button**
Controls the angle of the horizontal air deflector.
- **TIMER control**
Use this button to set the timer.
- **OFF-TIMER button** Select the turn OFF time.
- **ON-TIMER button** Select the turn ON time.
- **RESERVE button** Time setting reservation.
- **CANCEL button** Cancel time reservation.

	AUTO
	HEAT
	DEHUMIDIFY
	COOL
	FAN
	FAN SPEED LOW MED HI
	SLEEPING
	STOP (CANCEL)
	START (RESERVE)
	START/STOP
	TIME
	TIMER SET
	TIMER SELECTOR ON TIMER OFF TIMER
	AUTO SWING

Precautions for Use

- Do not put the remote controller in the following places.
 - Under direct sunlight.
 - In the vicinity of a heater.
- Handle the remote controller carefully. Do not drop it on the floor, and protect it from water.
- Once the outdoor unit stops, it will not restart for about 3 minutes (unless you turn the power switch off and on or unplug the power cord and plug it in again).
This is to protect the device and does not indicate a failure.
- If you press the FUNCTION selector button during operation, the device may stop for about 3 minutes for protection.

VARIOUS FUNCTIONS

■ Auto Restart Control

- If there is a power failure, operation will be automatically restarted when the power is resumed with previous operation mode and airflow direction.
(As the operation is not stopped by remote controller.)
- If you intend not to continue the operation when the power is resumed, switch off the power supply.
When you switch on the circuit breaker, the operation will be automatically restarted with previous operation mode and airflow direction.

Note: 1. If you do not require Auto Restart Control, please consult your sales agent or OFF by remote control.
2. Auto Restart Control is not available when Timer or Sleep Timer mode is set.

AUTOMATIC OPERATION

The device will automatically determine the mode of operation, HEAT, COOL or DEHUMIDIFY depending on the current room temperature. The selected mode of operation will change when the room temperature varies. However the mode of operation will not change when indoor unit connected to multi type outdoor unit.

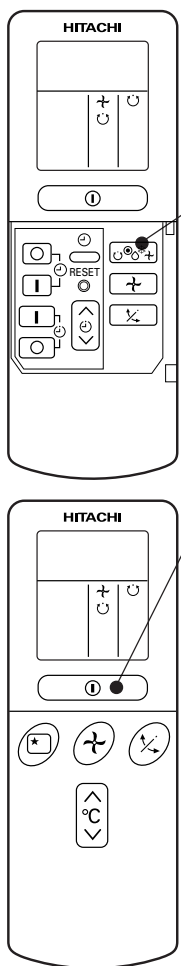

1 Press the FUNCTION selector so that the display indicates the (AUTO) mode of operation.

- When AUTO has been selected, the device will automatically determine the mode of operation, HEAT, COOL or DEHUMIDIFY depending on the current room temperature. However the mode of operation will not change when indoor unit connected to multi type outdoor unit.
- If the mode automatically selected by the unit is not satisfactory, manually change the mode setting (heat, dehumidify, cool or fan).

START STOP Press the (START/STOP) button.
Operation starts with a beep.
Press the button again to stop operation.

■ As the settings are stored in memory in the remote controller, you only have to press the (START/STOP) button next time.

You can raise or lower the temperature setting as necessary by maximum of 3°C.

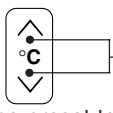

Press the temperature button and the temperature setting will change by 1°C each time.

- The preset temperature and the actual room temperature may vary somewhat depending on conditions.
- The display does not indicate the preset temperature in the AUTO mode. If you change the setting, the indoor unit will produce a beep.

Press the (FAN SPEED) button, AUTO and LOW is available.

HEATING OPERATION

- Use the device for heating when the outdoor temperature is under 21°C.
When it is too warm (over 21°C), the heating function may not work in order to protect the device.
- In order to keep reliability of the device, please use this device above -15°C of the outdoor temperature.

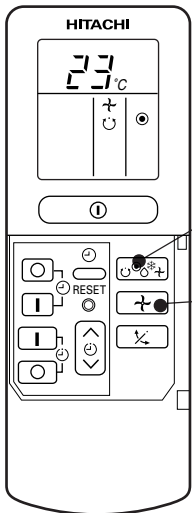

1

Press the FUNCTION selector so that the display indicates ● (HEAT).

2

Set the desired FAN SPEED with the ↻ (FAN SPEED) button (the display indicates the setting).

⌚ (AUTO): The fan speed is HI at first and varies to MED automatically when the preset temperature has been reached.

⌚ (HI) : Economical as the room will become warm quickly.
But you may feel a chill at the beginning.

⌚ (MED) : Fan speed slow.

⌚ (LOW) : Fan speed slower.

3

Set the desired room temperature with the TEMPERATURE buttons (the display indicates the setting).

The temperature setting and the actual room temperature may vary somewhat depending on conditions.

**START
STOP**

Press the ⏻ (START/STOP) button. Heating operation starts with a beep. Press the button again to stop operation.

- As the settings are stored in memory in the remote controller, you only have to press the ⏻ (START/STOP) button next time.

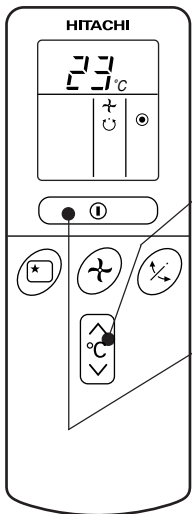

DEHUMIDIFYING OPERATION

Use the device for dehumidifying when the room temperature is over 16°C.
When it is under 15°C, the dehumidifying function will not work.

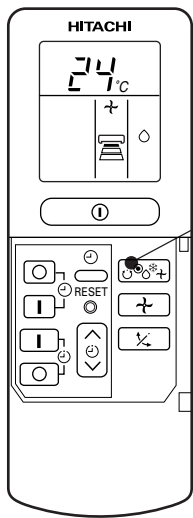

1

Press the FUNCTION selector so that the display indicates ◊ (DEHUMIDIFY).
The FAN SPEED is set at LOW automatically.
The FAN SPEED button does not work.

2

Set the desired room temperature with the TEMPERATURE button (the display indicates the setting).



The range of 20-26°C is recommended as the room temperature for dehumidifying.

START STOP

Press the Ⓜ (START/STOP) button. Dehumidifying operation starts with a beep. Press the button again to stop operation.

- As the settings are stored in memory in the remote controller, you only have to press the Ⓜ (START/STOP) button next time.

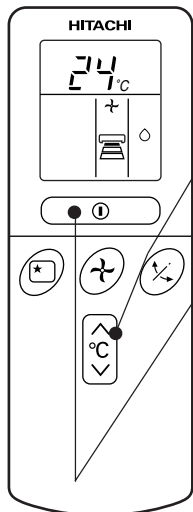

■ Dehumidifying Function

When the room temperature is higher than the temperature setting: The device will dehumidify the room, reducing the room temperature to the preset level.

When the room temperature is lower than the temperature setting: Dehumidifying will be performed at the temperature setting slightly lower than the current room temperature, regardless of the temperature setting. The function will stop (the indoor unit will stop emitting air) as soon as the room temperature becomes lower than the setting temperature.

COOLING OPERATION

Use the device for cooling when the outdoor temperature is 22-42°C.
 If in doors humidity is very high (80%), some dew may form on the air outlet grille of the indoor unit.

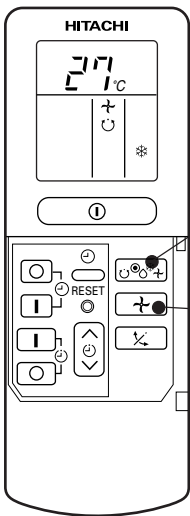

1

Press the FUNCTION selector so that the display indicates * (COOL).

2

Set the desired FAN SPEED with the \updownarrow (FAN SPEED) button (the display indicates the setting).

\updownarrow (AUTO): The FAN SPEED is HI at first and varies to MED automatically when the preset temperature has been reached.

(HI) : Economical as the room will become cool quickly.

(MED) : Fan speed slow.

(LOW) : Fan speed slower.

3

Set the desired room temperature with the TEMPERATURE button (the display indicates the setting).

The temperature setting and the actual room temperature may vary some how depending on conditions.

**START
STOP**

Press the O (START/STOP) button. Cooling operation starts with a beep. Press the button again to stop operation. The cooling function does not start if the temperature setting is higher than the current room temperature (even though the O (OPERATION) lamp lights). The cooling function will start as soon as you set the temperature below the current room temperature.

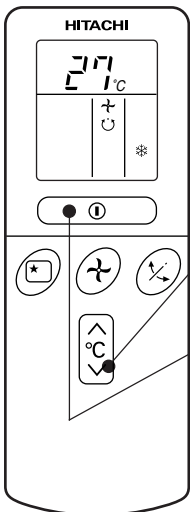

■ As the settings are stored in memory in the remote controller, you only have to press the O (START/STOP) button next time.

FAN OPERATION

You can use the device simply as an air circulator. Use this function to dry the interior of the indoor unit at the end of summer.

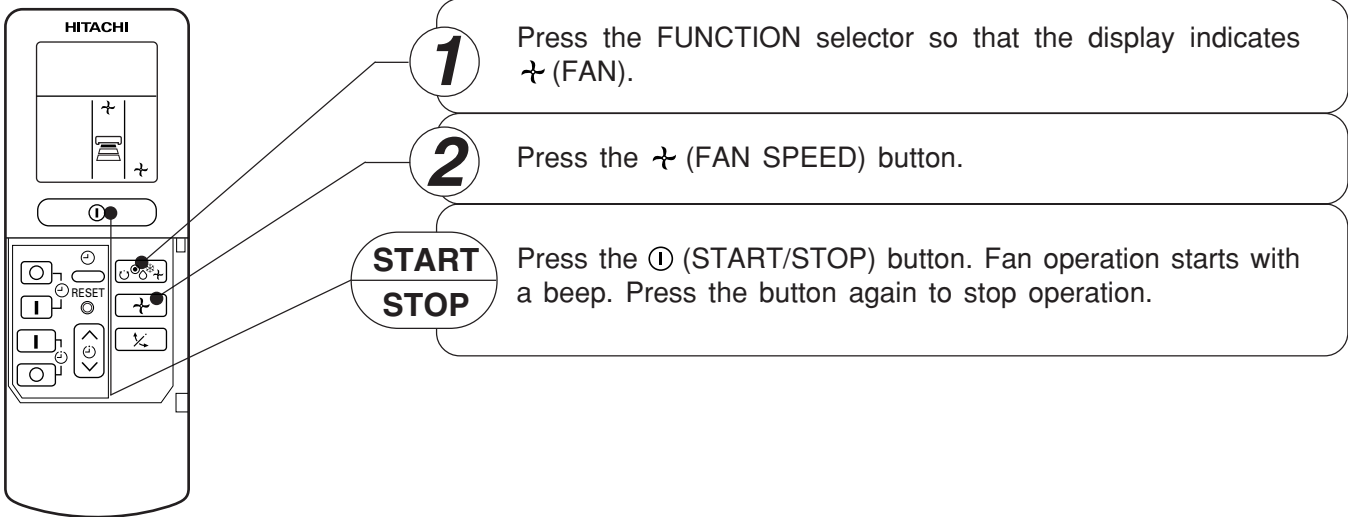

FAN SPEED (AUTO) When the AUTO fan speed mode is set in the cooling/heating operation:

For the heating operation	<ul style="list-style-type: none"> ● The fan speed will automatically change according to the temperature of discharged air. ● When the difference of room temperature and setting temperature is large, fan starts to run at HI speed. ● When the room temperature reaches setting temperature, fan speed changes to LOW automatically.
For the cooling operation	<ul style="list-style-type: none"> ● When the difference of room temperature and setting temperature is large, fan starts to run at HI speed. ● After room temperature reaches the preset temperature, the cooling operation, which changes the fan speed and room temperature to obtain optimum conditions for natural healthful cooling will be performed.

HOW TO SET THE TIMER

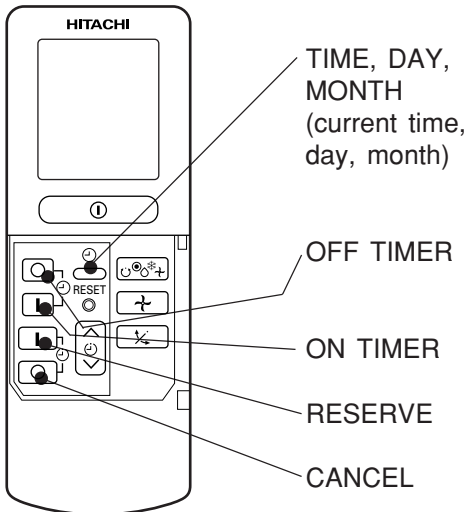

Time, Day, Month

After you change the batteries;

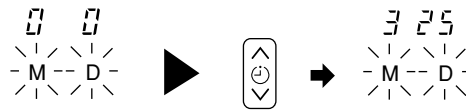

1 Set the current month and day with the TIMER control button.

OFF-Timer

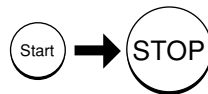

You can set the device to turn off at the present time.

1 Press the (OFF-TIMER) button. The (OFF) mark blinks on the display.

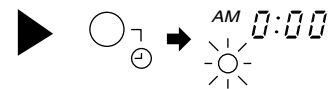

ON-Timer

- The device will turn on at the designated times.

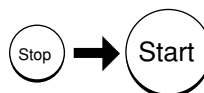

1 Press the (ON-TIMER) button the (ON) mark blinks on the display.

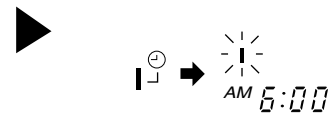

ON/OFF-Timer

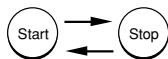

- The device will turn on (off) and off (on) at the designated times.
- The switching occurs first at the preset time that comes earlier.
- The arrow mark appearing on the display indicates the sequence of switching operations.

1 Press the (ON-OFF) button so that the (OFF) mark blinks.

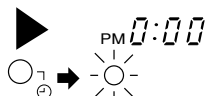

2 Set the turn-off time with the TIMER control button. Press the (RESERVE) button.

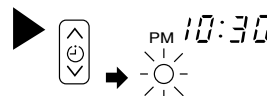

3 Press the (ON-TIMER) button so that the (OFF) mark lights and the (ON) mark blinks.

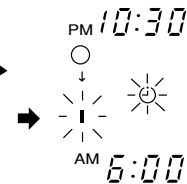

How to Cancel Reservation

Point the signal window of the remote controller toward the indoor unit, and press the (CANCEL) button.

The (RESERVED) sign goes out with a beep and the (TIMER) lamp turns off on the indoor unit.

NOTE

You can set only one of the OFF-timer, ON-timer and ON/OFF-timer.

2 Press the ⊖ (TIME) button.



3 Set the current time with the TIMER control button.

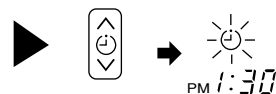

4 Press the ⊖ (TIME) button again. The time indication starts lighting instead of flashing.

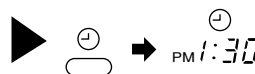

- The time indication will disappear automatically in 10 second.
- To check the current time setting, press the ⊖ (TIME) button twice.

The setting of the current time is now complete.

Example: The current time is 1:30 p.m.

2 Set the turn-off time with the TIMER control button.

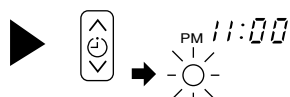

3 Point the signal window of the remote controller toward the indoor unit, and press the | (RESERVE) button.

The ○ (OFF) mark starts lighting instead of flashing and the sign ⊖ (RESERVED) lights. A beep occurs and the ⊖ (TIMER) lamp lights on the indoor unit.

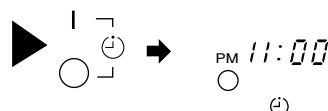

Example: The device will turn off at 11:00p.m.

The setting of turn-off time is now complete.

2 Set the turn-on time with the TIMER control button.



3 Point the signal window of the remote controller toward the indoor unit, and press the | (RESERVE) button.

The | (ON) mark starts lighting instead of flashing and the ⊖ (RESERVED) sign lights. A beep occurs and the ⊖ (TIMER) lamp lights on the indoor unit.

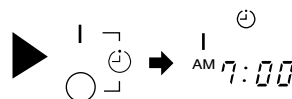

Example:
The device will turn on at 7:00 a.m.
The setting of the turn-on time is now complete.

4 Set the turn-on time with the TIMER control button.

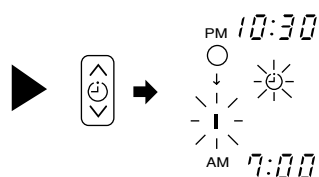

5 Point the signal window of the remote controller toward the indoor unit, and press the | (RESERVE) button.

The | (ON) mark starts lighting instead of flashing and the ⊖ (RESERVED) sign lights. A beep occurs and the ⊖ (TIMER) lamp lights on the indoor unit.

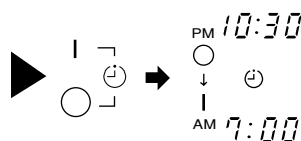

Example:
The device will turn off at 10:30 p.m. and it will be turned on at 7:00 a.m.
The settings of the turn-on/off times are now complete.

- The timer may be used in three ways: off-timer, on-timer, and ON/OFF (OFF/ON)-timer. Set the current time at first because it serves as a reference.
- As the time settings are stored in memory in the remote controller, you only have to press the | (RESERVE) button in order to use the same settings next time.

HOW TO SET THE SLEEP TIMER

Set the current time at first if it is not set before (see the pages for setting the current time). Press the  (SLEEP) button, and the display changes as shown below.

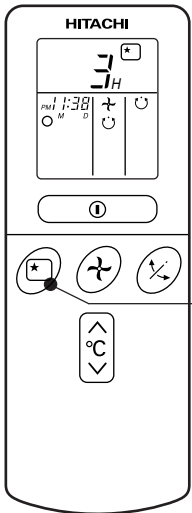

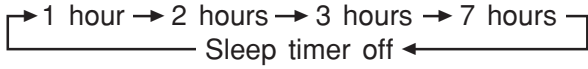
Mode	Indication
Sleep timer	

Sleep Timer: The device will continue working for the designated number of hours and then turn off. Point the signal window of the remote controller toward the indoor unit, and press the SLEEP button. The timer information will be displayed on the remote controller. The TIMER lamp lights with a beep from the indoor unit. When the sleep timer has been set, the display indicates the turn-off time.

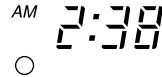

Example: If you set 3 hours sleep time at 11:38 p.m., the turn-off time is 2:38 a.m.

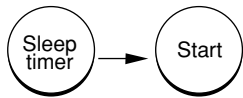

The device will be turned off by the sleep timer and turned on by on-timer.

1 Set the ON-timer.

2 Press the  (SLEEP) button and set the sleep timer.

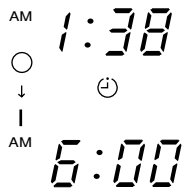
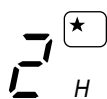



For heating:

In this case, the device will turn off in 2 hours (at 1:38 a.m.) and turn on early so that the preset temperature will be almost reached at 6:00 next morning.

How to Cancel Reservation

Point the signal window of the remote controller toward the indoor unit, and press the  (CANCEL) button.



The  (RESERVED) sign goes out with a beep and the  (TIMER) lamp turns off on the indoor unit.

ADJUSTING THE AIR DEFLECTOR

1 Adjustment of the conditioned air in the upward and downward directions.

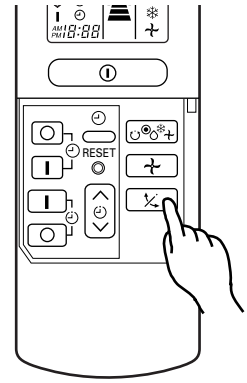
According to “Dehumidifying” or “Cooling” operation, the horizontal air deflector is automatically set to the proper angle suitable for each operation. The deflector can be swung up and down and also set to the desired angle using the “ (AUTO SWING)” button. (If the angle of the deflector is changed, it will not return to the auto-set position after operations start unless the operation mode is switched.)



- If the “ (AUTO SWING)” button is pressed once, the horizontal air deflector swings up and down. If the button is pressed again, the deflector stops in its current position. Several seconds (about 6 seconds) may be required before the deflector starts to move.
- Use the horizontal air deflector within the adjusting range shown on the right.
- When the “ (AUTO SWING)” button is pressed while the operation is stopped, the horizontal air deflector moves and stops at the position where the air outlet closes.
- When the auto swing operation is performed, if the horizontal air deflector is moved manually, the swinging range may drift. However, it will return to the original operation range after a short time.

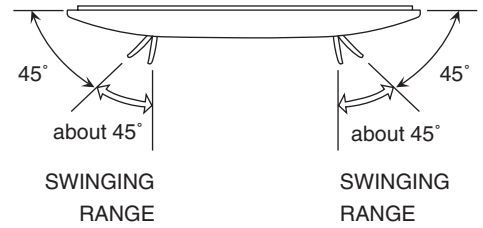

⚠ CAUTION

When operating the unit in cooling operation with the air deflector facing down and moving automatically for a long period of time, water will condensed on the air deflector and drips down occasionally. This will wet your furniture.

HOW TO EXCHANGE THE BATTERIES IN THE REMOTE CONTROLLER

1 Remove the cover as shown in the figure and take out the old batteries.



2 Install the new batteries.
The direction of the batteries should match the marks in the case.

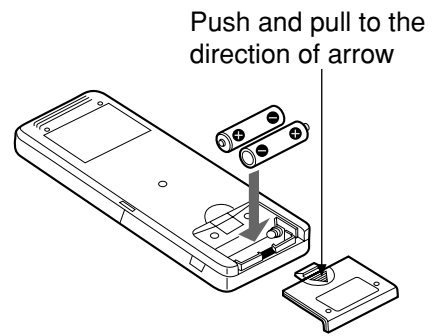

⚠ CAUTION

1. Do not use new and old batteries, or different kinds of batteries together.
2. Take out the batteries when you do not use the remote controller for 2 or 3 months.

Suitable Room Temperature

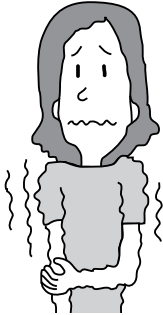

⚠ Warning
Freezing temperature is bad for health and a waste of electric power.

Install curtain or blinds

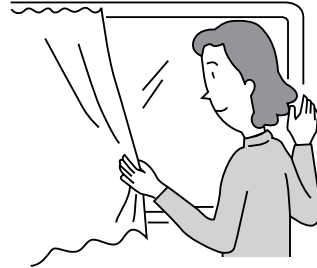

It is possible to reduce heat entering the room through windows.

Ventilation

⚠ Caution
Do not close the room for a long period of time. Occasionally open the door and windows to allow the entrance of fresh air.



Effective Usage Of Timer

At night, please use the “OFF or ON timer operation mode”, together with your wake up time in the morning. This will enable you to enjoy a comfortable room temperature. Please use the timer effectively.

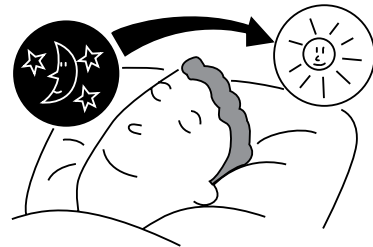

Do Not Forget To Clean The Air Filter

Dusty air filter will reduce the air volume and the cooling efficiency. To prevent from wasting electric energy, please clean the filter every 2 weeks.

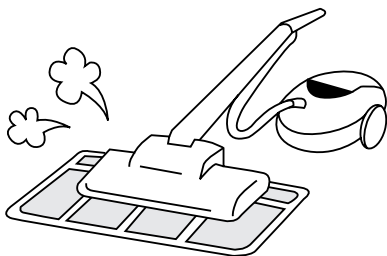

Please Adjust Suitable Temperature For Baby And Children

Please pay attention to the room temperature and air flow direction when operating the unit for baby, children and old folks who have difficulty in movement.

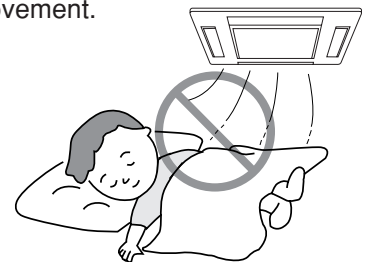

FOR USER'S INFORMATION

The Air Conditioner And The Heat Source In The Room

⚠ Caution

If the amount of heat in the room is above the cooling capability of the air conditioner (for example: more people entering the room, using heating equipments and etc.), the preset room temperature cannot be achieved.



Not Operating For A Long Time

When the indoor unit is not to be used for a long period of time, please switch off the power from the mains. If the power from mains remains "ON", the indoor unit still consumes about 8W in the operation control circuit even if it is in "OFF" mode.

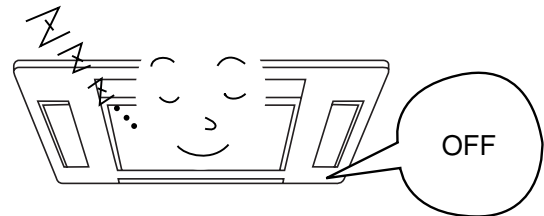

When Lightning Occurs

⚠ Warning

To protect the whole unit during lightning, please stop operating the unit and remove the plug from the socket.



Interference From Electrical Products

⚠ Caution

To avoid noise interference, please place the indoor unit and its remote controller at least 1m away from electrical products.

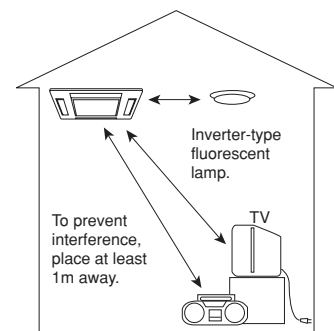

⚠ CAUTION

Cleaning and maintenance must be carried out by qualified service personnel.
Before the cleaning, stop operation and disconnect the power supply.
Clean the filter at least once every one month. This helps save electricity cost.

1. CLEANING OF AIR FILTER

REMOVAL AND ATTACHMENT OF AIR FILTER

PROCEDURE

- 1** Remove the filter from indoor
 - Press the mark "PUSH" on the left and right sides of the suction grille.
 - Pull out the filter from the grille.
- 2** Remove dust from the filter using a vacuum cleaner.
If there is too much dust, use neutral detergent. After using neutral detergent, wash with clean water and dry in the shade.
- 3** Install the filter. (Set it with "UP SIDE" mark facing front.)
Slot the filter to suction grille and close as original state.
(Press the mark "PUSH" at the left and right sides of the suction grille to fix it securely.)

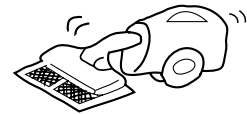
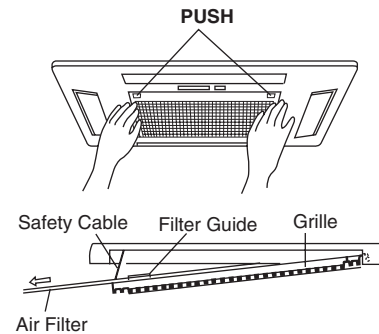

Note:

- This model has an air cleaning filter. The cooling capacity is slightly weakened and the cooling speed becomes slower when the air cleaning filter is used. So, set the fan speed to "HIGH" when using it in this condition.
- Recommended to replace the air cleaning filter after every 3 months for normal usage. Type number for this air cleaning filter is <SPX-CFH5>. Please use this number for ordering when you want to renew it.

⚠ CAUTION

- Do not wash with hot water at more than 40°C. The filter may shrink.
- When washing it, shake off moisture completely and dry it in the shade; do not expose it directly to the sun. The filter may shrink.
- Do not operate the air conditioner with the filter removed. Dust may enter the air conditioner and cause trouble.

2. CLEANING OF FRONT PANEL

- Wipe it with a soft dry cloth.
- When it is excessively dirty, wipe with soft cloth soaked in lukewarm water or neutral detergent. Then wipe thoroughly with a soft dry cloth.

⚠ CAUTION

- Do not splash or direct water to the body of the unit when cleaning it as this may cause short circuit.
- Never use hot water (above 40°C), benzine, gasoline, acid, thinner or a brush, because they will damage the plastic surface and the coating.



3. MAINTENANCE AT BEGINNING OF LONG OFF PERIOD

- Running the unit setting the operation mode to ↻ (FAN) and the fan speed to HI for about half a day on a fine day, and dry the whole of the unit.
- Turn off the circuit breaker.

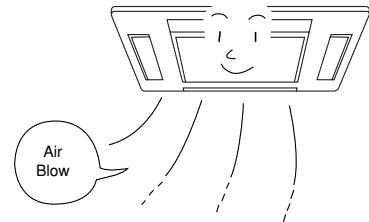

REGULAR INSPECTION

PLEASE CHECK THE FOLLOWING POINTS EITHER EVERY HALF YEARLY OR YEARLY. CONTACT YOUR SALES AGENT SHOULD YOU NEED ANY HELP.

1		<p>Is the earth line disconnected or broken?</p> <p>⚠ WARNING Coming off or breakage of grounding wire may cause malfunction or electrical shock.</p>
2		<p>Is the mounting frame seriously affected by rust and is the outdoor unit tilted or unstable?</p> <p>⚠ WARNING Outdoor unit may fall or drop if there is extreme rust on mounting frame or outdoor unit is unstably installed. This may cause injury.</p>
3		<p>Is the plug of power line firmly plugged into the socket? (Please ensure no loose contact between them).</p>

AFTER SALES SERVICE AND WARRANTY

WHEN ASKING FOR SERVICE, CHECK THE FOLLOWING POINTS.

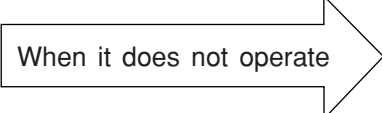
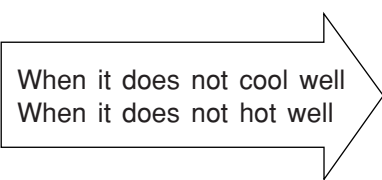
CONDITION	CHECK THE FOLLOWING POINTS
 <p>When it does not operate</p>	<ul style="list-style-type: none"> ● Is the fuse blown out or the circuit breaker tripped? ● Is the voltage normal? ● Is the circuit breaker "ON"?
 <p>When it does not cool well When it does not hot well</p>	<ul style="list-style-type: none"> ● Is the air filter blocked with dust? ● Does sunlight fall directly on the outdoor unit? ● Is the air flow of the outdoor unit obstructed? ● Are the doors or windows opened, or is there any source of heat in the room? ● Is the set temperature suitable?



Notes

- In quiet operation or stopping the running, the following phenomena may occasionally occur, but they are not abnormal for the operation.
 - (1) Slight flowing noise of refrigerant in the refrigerating cycle.
 - (2) Slight rubbing noise from the fan casing which is cooled and then gradually warmed as operation stops.
- The odor will possibly be emitted from the room air conditioner because the various odor, emitted by smoke, foodstuffs, cosmetics and so on, sticks to it. So please clean the air filter and the evaporator regularly to reduce the odor.

- Please contact your sales agent immediately if the air conditioner still fails to operate normally after the above inspections. Inform your agent of the model of your unit, production number, date of installation. Please also inform him regarding the fault.
- Power supply shall be connected at the rated voltage, otherwise the unit will be broken or could not reach the specified capacity.

CONSTRUCTION AND DIMENSIONAL DIAGRAM

MODEL RAI-25NH4, RAI-40NH4

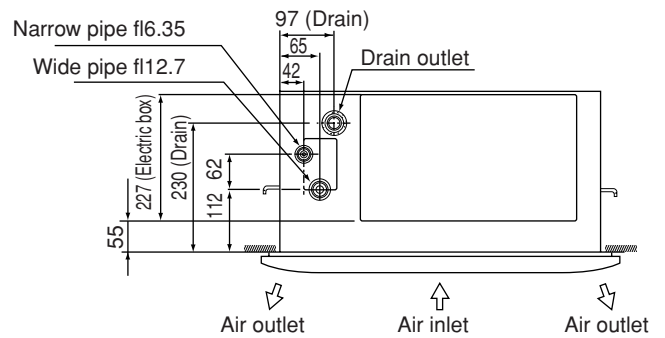
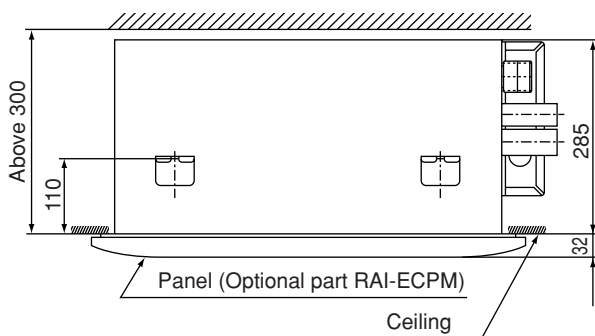
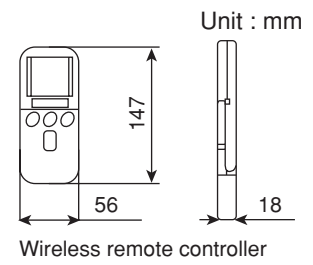
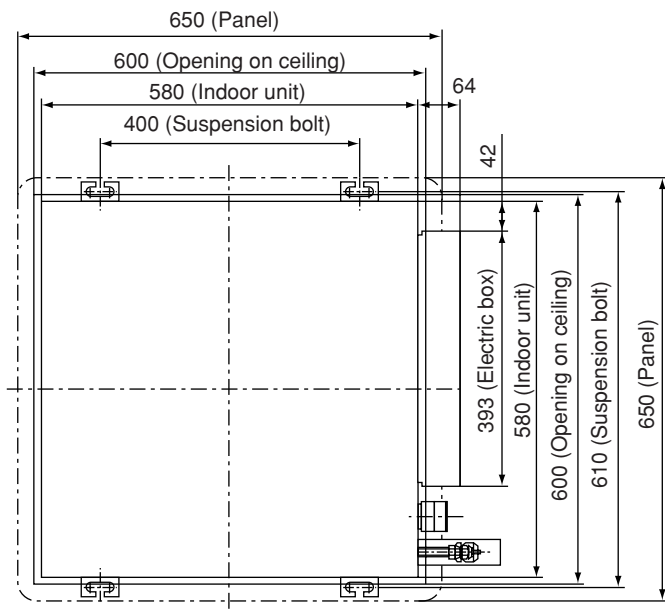

Note:

1. Insulated pipes should be used for both the narrow and wide dia. pipes.
2. Piping length is within 20m.
3. Height difference of the piping between the indoor unit and the outdoor unit should be within 10m.
4. An F-cable 1.6mm or 2.0mm dia. X 3 (control side) is used for the connection cable.

CONSTRUCTION AND DIMENSIONAL DIAGRAM FOR OUTDOOR

MODEL RAC-25NH4

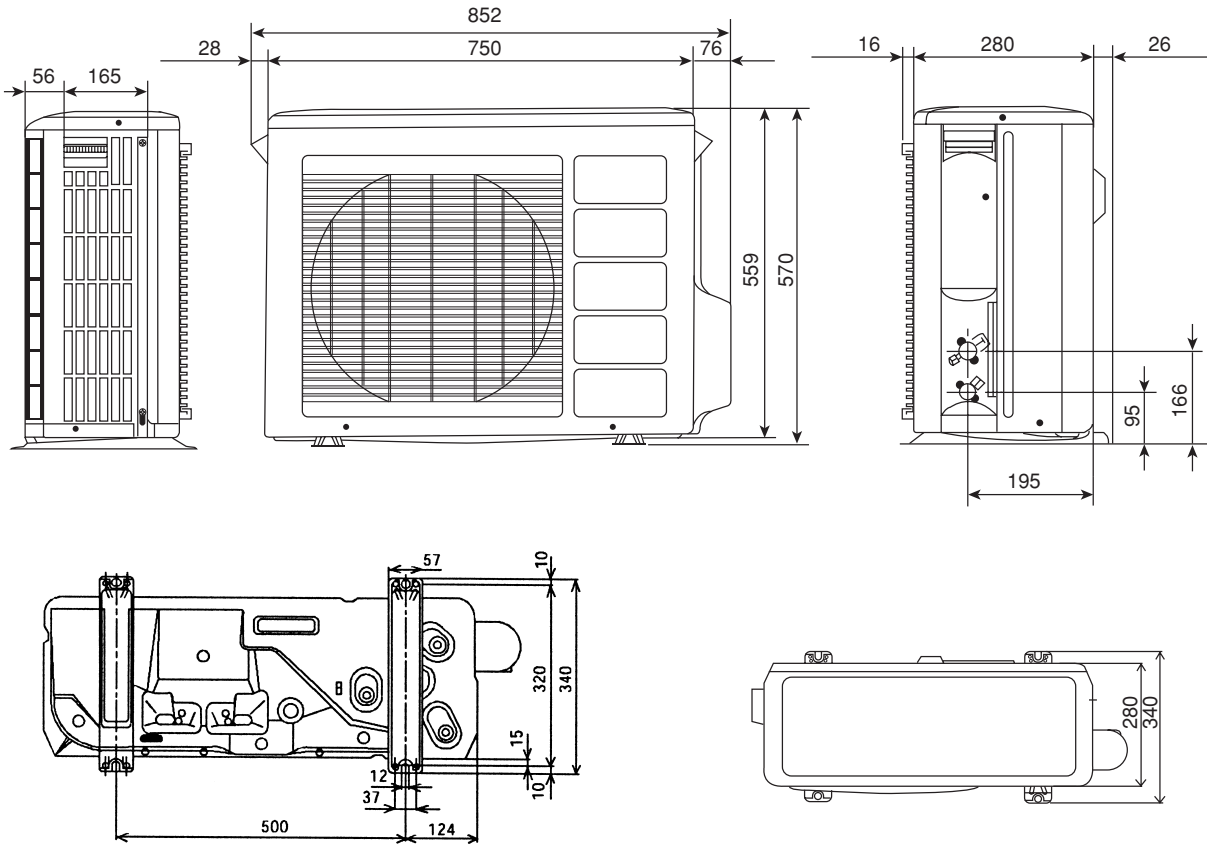

MODEL RAC-50NH4

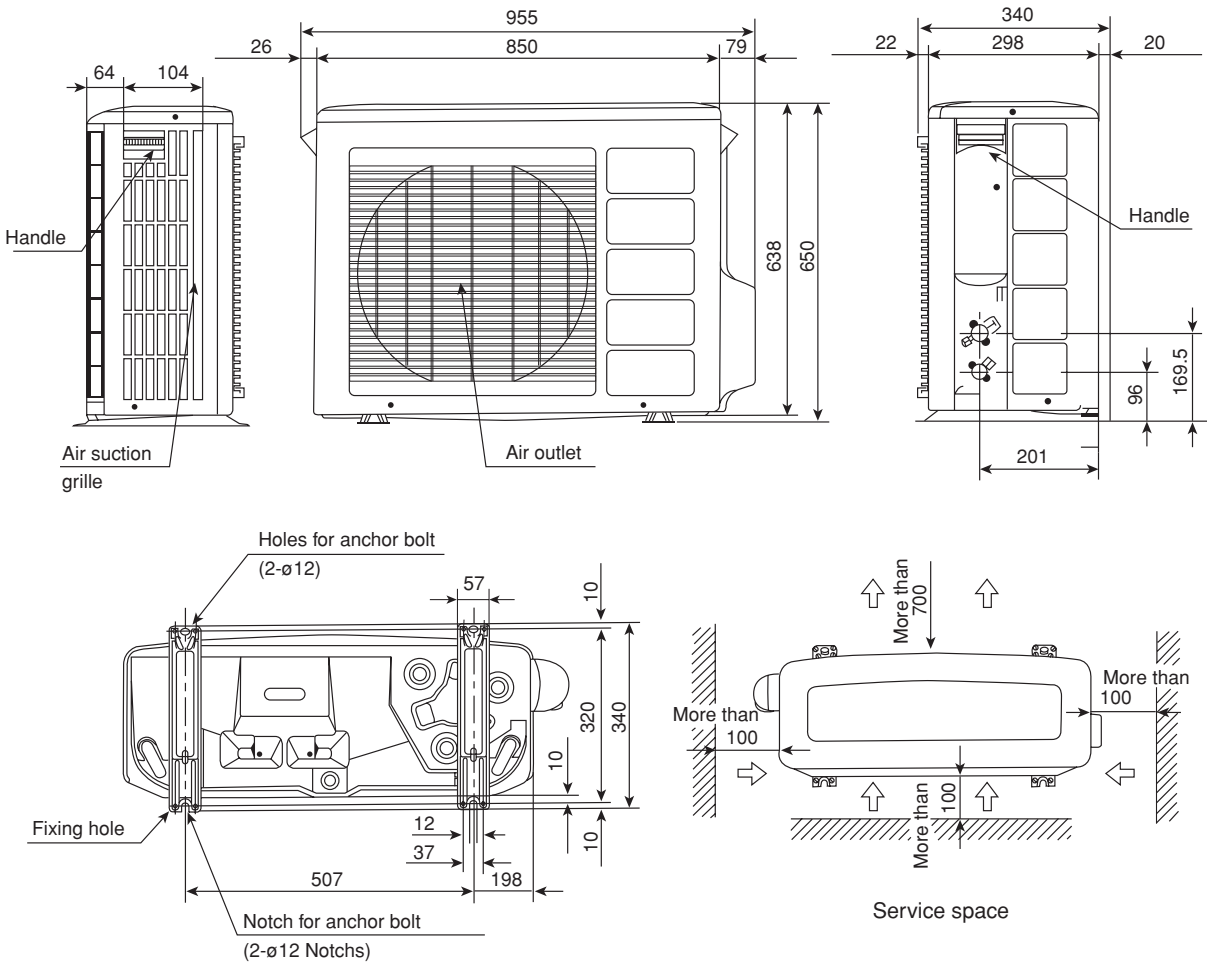

MAIN PARTS COMPONENT

THERMOSTAT

Thermostat Specifications

THERMOSTAT MODEL			IC		
OPERATION MODE			COOL		HEAT
MODEL			RAI-25NH4	RAI-40NH4	RAI-25NH4, RAI-40NH4
TEMPERATURE °C (°F)	INDICATION 16	ON	15.0 (59.0)	13.0 (55.4)	20.0 (68.0)
		OFF	14.7 (58.5)	12.7 (54.9)	20.3 (68.5)
	INDICATION 24	ON	23.0 (73.4)	21.0 (69.8)	28.0 (82.4)
		OFF	22.7 (72.9)	20.7 (69.3)	28.3 (82.9)
	INDICATION 32	ON	31.0 (87.8)	29.0 (84.2)	36.0 (96.8)
		OFF	30.7 (87.3)	28.7 (83.7)	36.3 (97.9)

FAN MOTOR

Fan Motor Specifications

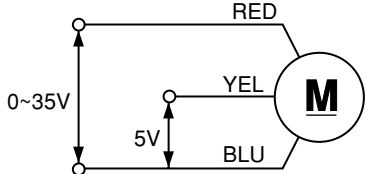
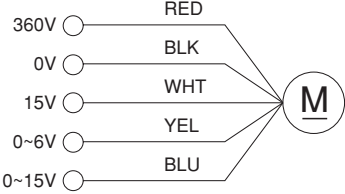
MODEL	RAI-25NH4 RAI-40NH4	RAC-25NH4 RAC-50NH4
POWER SOURCE	DC: 0 ~ 35V	DC360V
OUTPUT	25W	40W
CONNECTION	 <p>(Control circuit built in)</p>	

BLU : BLUE

YEL : YELLOW

BRN : BROWN

WHT : WHITE

GRY : GRAY

ORN : ORANGE

GRN : GREEN

RED : RED

BLK : BLACK

PNK : PINK

VIO : VIOLET

COMPRESSOR MOTOR

Compressor Motor Specifications

MODEL	RAC-25NH4	RAC-40NH4
COMPRESSOR MODEL	JU1012D	JU1013D
PHASE	SINGLE	
RATED VOLTAGE	AC 220 ~ 240 V	
RATED FREQUENCY	50 Hz	
POLE NUMBER	4	
CONNECTION		
RESISTANCE VALUE (Ω)	20°C (68°F)	2M = 1.05
	75°C (167°F)	2M = 1.28

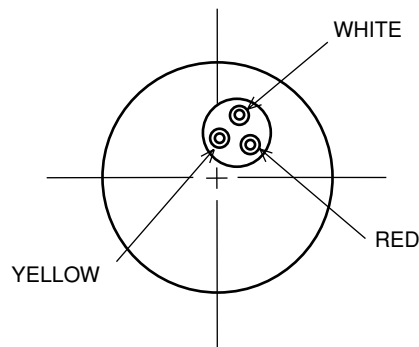

CAUTION

When the refrigerating cycle has been operated for a long time with the capillary tubes clogged or crushed or with too little refrigerant, check the color of the refrigerating machine oil inside the compressor. If the color has been changed conspicuously, replace the compressor.

WIRING DIAGRAM

MODEL RAI-25NH4 / RAC-25NH4
RAI-40NH4 / RAC-40NH4

INDOOR UNIT

OUTDOOR UNIT

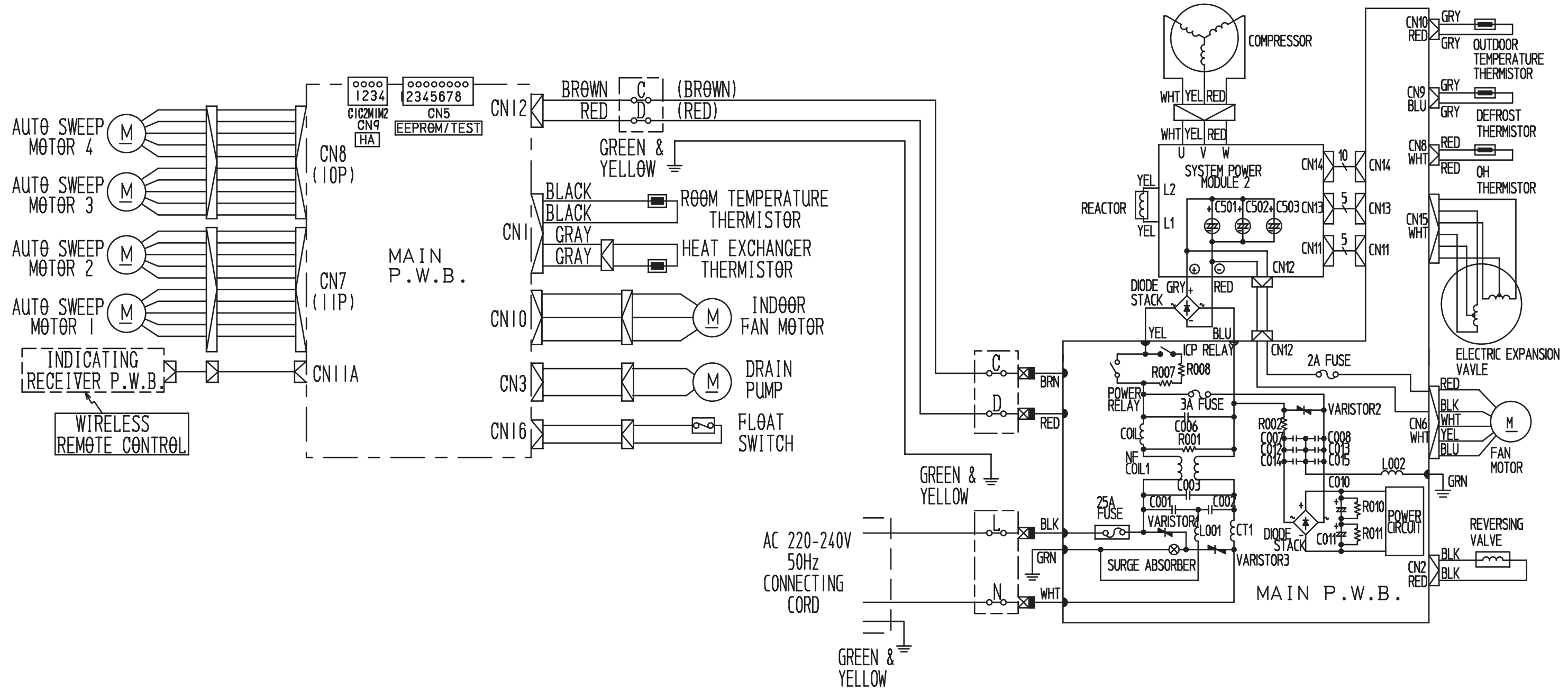

CIRCUIT DIAGRAM

Remote Control

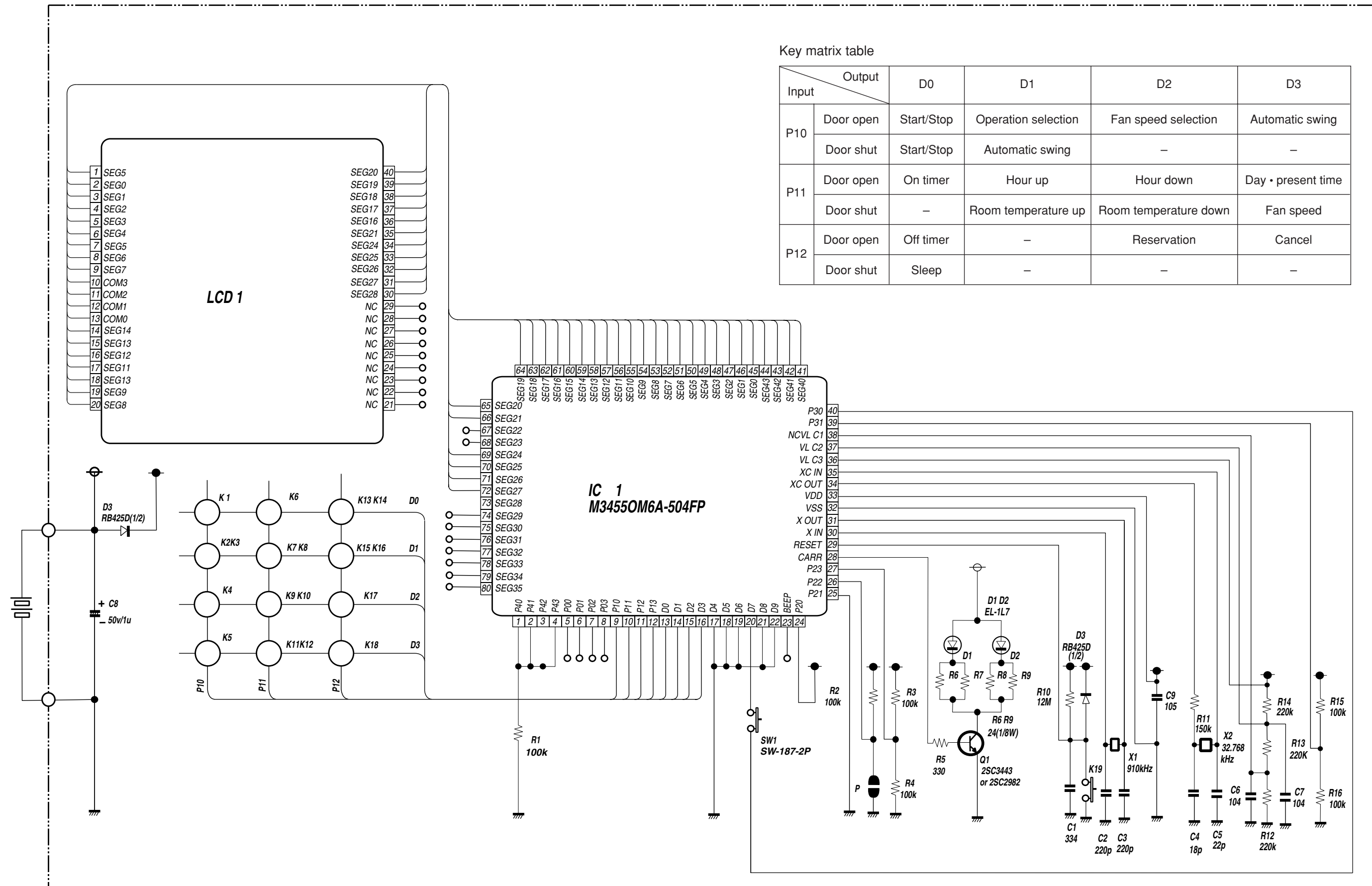

Key matrix table

Input \ Output		D0	D1	D2	D3
		D0	D1	D2	D3
P10	Door open	Start/Stop	Operation selection	Fan speed selection	Automatic swing
	Door shut	Start/Stop	Automatic swing	-	-
P11	Door open	On timer	Hour up	Hour down	Day · present time
	Door shut	-	Room temperature up	Room temperature down	Fan speed
P12	Door open	Off timer	-	Reservation	Cancel
	Door shut	Sleep	-	-	-

CIRCUIT DIAGRAM

MODEL RAI-25NH4, RAI-40NH4

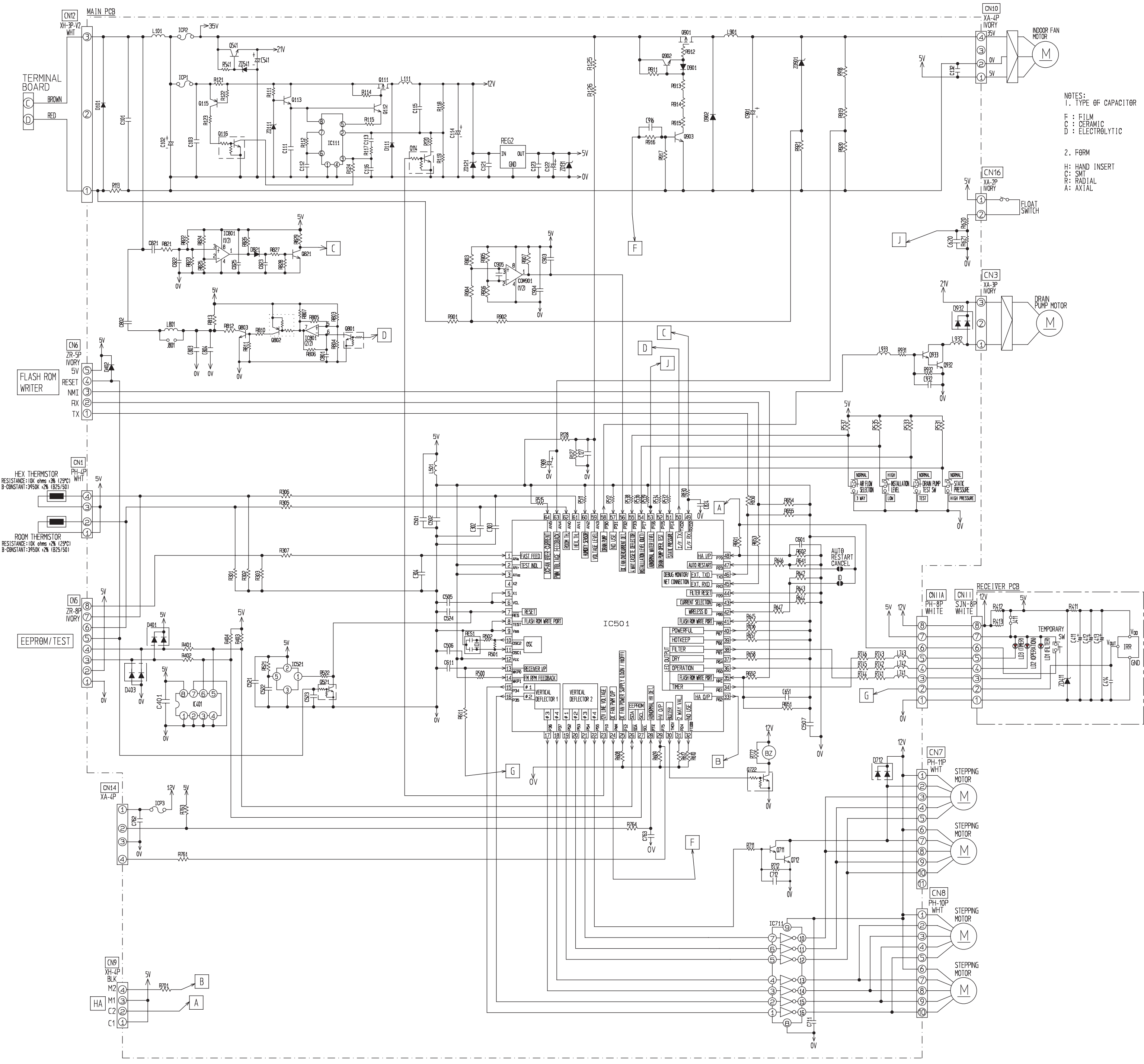

NOTES:
 1. TYPE OF CAPACITOR
 F: FILM
 C: CERAMIC
 D: ELECTROLYTIC
 2. FORM
 H: HAND INSERT
 C: SMT
 R: RADIAL
 A: AXIAL

RESISTOR

SYMBOL	Ω	±%	P/W	FORM
R111	27k	±5%	1/16	C
R112	30k	±5%	1/16	C
R113	0.3	±5%	1	H
R114	750	±5%	1/8	C
R115	560	±5%	1/8	C
R117	68k	±5%	1/16	C
R118	75k	±2%	1/16	C
R119	6.98k	±2%	1/16	C
R121	0.56	±5%	1/4W	C
R122	100	±5%	1/16	C
R123	33k	±5%	1/16	C
R124	100	±5%	1/16	C
R125	1k	±5%	1/16	C
R126	1k	±5%	1/16	C
R127	1k	±5%	1/16	C
R128	10k	±5%	1/16	C
R301	12.7k	±1%	1/16	C
R302	12.7k	±1%	1/16	C
R303	10k	±5%	1/16	C
R305	1k	±5%	1/16	C
R306	1k	±5%	1/16	C
R307	1k	±5%	1/16	C
R401	390	±5%	1/16	C
R402	390	±5%	1/16	C
R403	5.1k	±5%	1/16	C
R404	5.1k	±5%	1/16	C
R411	10k	±5%	1/16	C
R412	10k	±5%	1/16	C
R413	10k	±5%	1/16	C
R45	10k	±5%	1/16	C
R46	1k	±5%	1/16	C
R47	1k	±5%	1/16	C
R48	1k	±5%	1/16	C
R49	1k	±5%	1/16	C
R50	1k	±5%	1/16	C
R51	1k	±5%	1/16	C
R52	1k	±5%	1/16	C
R53	1k	±5%	1/16	C
R54	1k	±5%	1/16	C
R55	1k	±5%	1/16	C
R56	1k	±5%	1/16	C
R57	1k	±5%	1/16	C
R58	1k	±5%	1/16	C
R59	1k	±5%	1/16	C
R60	1k	±5%	1/16	C
R61	1k	±5%	1/16	C
R62	1k	±5%	1/16	C
R63	1k	±5%	1/16	C
R64	1k	±5%	1/16	C
R65	1k	±5%	1/16	C
R66	1k	±5%	1/16	C
R67	1k	±5%	1/16	C
R68	1k	±5%	1/16	C
R69	1k	±5%	1/16	C
R70	1k	±5%	1/16	C
R71	1k	±5%	1/16	C
R72	1k	±5%	1/16	C
R73	1k	±5%	1/16	C
R74	1k	±5%	1/16	C
R75	1k	±5%	1/16	C
R76	1k	±5%	1/16	C
R77	1k	±5%	1/16	C
R78	1k	±5%	1/16	C
R79	1k	±5%	1/16	C
R80	1k	±5%	1/16	C
R81	1k	±5%	1/16	C
R82	1k	±5%	1/16	C
R83	1k	±5%	1/16	C
R84	1k	±5%	1/16	C
R85	1k	±5%	1/16	C
R86	1k	±5%	1/16	C
R87	1k	±5%	1/16	C
R88	1k	±5%	1/16	C
R89	1k	±5%	1/16	C
R90	1k	±5%	1/16	C
R91	1k	±5%	1/16	C
R92	1k	±5%	1/16	C
R93	1k	±5%	1/16	C
R94	1k	±5%	1/16	C
R95	1k	±5%	1/16	C
R96	1k	±5%	1/16	C
R97	1k	±5%	1/16	C
R98	1k	±5%	1/16	C
R99	1k	±5%	1/16	C
R100	1k	±5%	1/16	C

CAPACITOR

SYMBOL	μF	V	TYPE	FORM
C101	0.22	50	F	H
C102	330	63	DIPF	H
C103	470P	630	C	C
C111	2.2	10	CB	C
C112	1000P	50	CB	C
C113	0.047	25	CB	C
C114	220	35	DIPF	H
C115				
C116				
C121	0.1	25	CB	C
C122	100	10	DIPF	H
C123	0.1	25	CB	C
C127				
C132	0.1	25	CB	C
C302	0.1	25	CB	C
C303	0.1	25	CB	C
C304	0.1	25	CB	C
C401	0.1	25	CB	C
C411	47	16	D	R
C412	47	16	D	R
C413				
C414				
C501	0.1	25	CB	C
C502	0.1	25	CB	C
C505	0.1	25	CB	C
C506	0.1	25	CB	C
C507	0.1	25	CB	C
C521	0.1	25	CB	C
C522	0.22	10	CB	C
C523	0.1	25	CB	C
C524	0.1	25	CB	C
C541	100	50	DIPF	R
C601	0.1	25	CB	C
C611	1000P	50	CB	C
C620	0.1	25	CB	C
C651	0.1	25	CB	C
C711	0.1	25	CB	C
C712				
C762				
C763	0.1	25	CB	C
C801	50P	50	CB	C
C802	0.22	50	F	H
C803	0.1	25	CB	C
C804				
C821	0.01	50	F	H
C822	1000P	50	CB	C
C823	0.047	25	CB	C
C824	0.01	50	CB	C
C825	0.1	25	CB	C
C901	330	63	DIPF	H
C903	1000P	50	CB	C
C904	0.1	25	CB	C
C905	1	16	CB	C
C909	10	16	DVX	H
C916				
C932	1	16	CB	C

CONNECTORS

SYMBOL	MODEL NO.	COLOR	FORM	REMARK
CN1	PH-4P (TOP ENTRY)	WHITE	H	ROOM HEAT EXCHG THERMISTOR
CN3	XA-3P-V2 (TOP ENTRY)	IVORY	H	DRAIN PUMP
CN5	ZR-8P (TOP ENTRY)	IVORY	H	EEPROM / TEST
CN6	ZR-8P (TOP ENTRY)	IVORY	H	FLASH ROM
CN7	PH-4P (TOP ENTRY)	WHITE	H	STEPPING MOTOR
CN8	PH-4P (TOP ENTRY)	WHITE	H	STEPPING MOTOR
CN9	XH-4P (TOP ENTRY)	BLACK	H	HA
CN10	XA-4P (TOP ENTRY)	IVORY	H	INDOOR PAN FAN
CN11	SH-8P (SIDE ENTRY)	WHITE	H	R BOARD
CN11A	PH-8P (TOP ENTRY)	WHITE	H	R BOARD
CN12	XH-3P-V2 (TOP ENTRY)	WHITE	H	35V SUPPLY
CN14	XA-7P (TOP ENTRY)	IVORY	H	FLOAT SW

SWITCH

SYMBOL	MODEL	FORM
TEMPORARY SW	SKH-LU-SW	H
DRAIN PUMP TEST SW	SSSS9AE	H
START PRESSURE	SSSS9AE	H
AIR FLOW SELECTION	SSSS9AE	H
INSTALLATION LEVEL	SSSS9AE	H

TRANSISTOR

SYMBOL	MODEL	FORM		
Q111	2S4J51B	C		
Q112	2SC5209H	C		
Q113	2SC5209H	C		
Q114				
Q115	2SA1162Y	C		
Q116	RN1102	C		
Q521	RN1102	C		
Q541	2SD1266-P	H		
C762				
C763	0.1	25	CB	C
C801	50P	50	CB	C
C802	0.22	50	F	H
C803	0.1	25	CB	C
C804				
C821	0.01	50	F	H
C822	1000P	50	CB	C
C823	0.047	25	CB	C
C824	0.01	50	CB	C
C825	0.1	25	CB	C
C901	330	63	DIPF	H
C903	1000P	50	CB	C
C904	0.1	25	CB	C
C905	1	16	CB	C
C909	10	16	DVX	H
C916				
C932	1	16	CB	C

CHIP JUMPER

SYMBOL	USAGE	FORM
J11	EXIST	A
J801	NONE	C

BUZZER

SYMBOL	MODEL	FORM
BZ	PKM13EPEY	H

LIGHT RECEIVING UNIT

SYMBOL	MODEL	FORM
LTR	GPLW28RA	H

LED

SYMBOL	MODEL	COLOR	FORM
L101	SEL5420E	RED	H
L102	SEL5720K	YEL	H
L103	SEL5420A	GRN	H

DIODE

SYMBOL	MODEL	FORM
D101	G4DL-6440	H
D111	D1F56	C
D401	DAN202K	C
D402	ISS355	C
D403	DAP202K	C
D712	DAN202K	C
D821	ISS355	C
D901	LF801	C
D902	D1FL20U	C
D932	DAN202K	C

CIRCUIT DIAGRAM

MODEL RAC-25NH4
RAC-50NH4

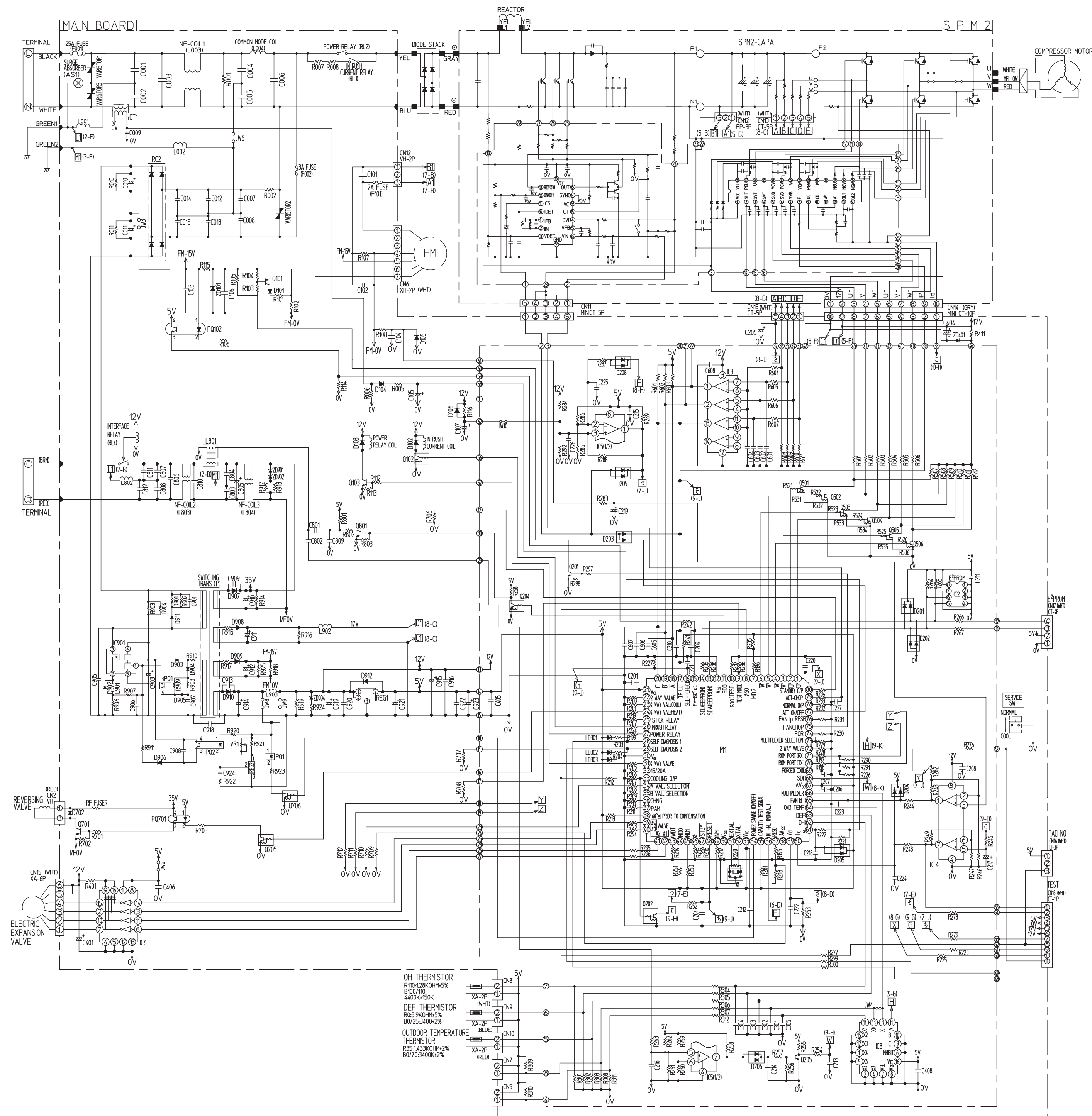

MONITORING BOARD
A: AXIAL (R1,R2)
R: RADIAL (R1,R2)
P: RADIAL (7.5MM PITCH)
H: MANUAL INSERT

HIC: HYBRID IC
M: MAIN BOARD

COMPONENT TYPE
C: CERAMIC
F: FILM
D: ELECTROLYTIC

RESISTORS

MARK	RATING (R) (%) (W)	REMARK
R001	470K 5% 1/2 A M	
R002	2.2 5% 1/4 W M	
R005	1.65K 5% 1/4 A M	
R006	1K 5% 1/4 A M	
R007	100 5% 1/4 W M	
R008	100 5% 1/4 W M	
R010	470K 5% 1/2 A M	
R011	470K 5% 1/2 A M	

RESISTORS

MARK	RATING (R) (%) (W)	REMARK
R308	3.0K 5% 1/4 A M	
R309	5.6K 5% 1/4 A M	
R310	5.6K 5% 1/4 A M	
R311	10K 5% 1/4 A M	
R312	100 5% 1/4 W M	

RESISTORS

MARK	RATING (R) (%) (W)	REMARK
R401	100 5% 1/4 A M	
R501	1K 5% 1/4 W M	
R502	1K 5% 1/4 W M	
R503	1K 5% 1/4 W M	
R504	1K 5% 1/4 W M	
R505	1K 5% 1/4 W M	
R506	1K 5% 1/4 W M	
R507	5.6K 5% 1/4 W M	
R508	5.6K 5% 1/4 W M	
R509	5.6K 5% 1/4 W M	
R510	5.6K 5% 1/4 W M	
R511	5.6K 5% 1/4 W M	
R512	5.6K 5% 1/4 W M	
R513	5.6K 5% 1/4 W M	
R514	5.6K 5% 1/4 W M	
R515	5.6K 5% 1/4 W M	
R516	5.6K 5% 1/4 W M	

CAPACITORS

MARK	RATING (U) (V)	REMARK
C001	0.01 25 C P M	
C002	0.01 25 C P M	
C003	0.68 25V 25V F H M	
C004	0.01 25 C P M	
C005	0.01 25 C P M	
C006	4 400 F H M WITHIN	
C007	0.01 25 C P M	
C008	0.01 25 C P M	
C009	0.1 50 C R M	
C010	100 250 D R M	
C011	100 250 D R M	
C012	0.01 25 C P M	
C013	0.01 25 C P M	
C014	0.01 25 C P M	
C015	0.01 25 C P M	
C016	0.01 25 C P M	
C017	0.01 25 C P M	
C018	0.01 25 C P M	
C019	0.01 25 C P M	
C020	0.01 25 C P M	
C021	0.047 25 C C HL 1608	
C022	0.01 25 C P M	
C023	0.01 25 C P M	
C024	0.01 25 C P M	
C025	0.01 25 C P M	
C026	0.01 25 C P M	
C027	0.01 25 C P M	
C028	0.047 25 C C HL 1608	
C029	0.047 25 C C HL 1608	
C030	0.047 25 C C HL 1608	
C031	0.047 25 C C HL 1608	
C032	0.047 25 C C HL 1608	
C033	0.047 25 C C HL 1608	
C034	0.047 25 C C HL 1608	
C035	0.047 25 C C HL 1608	
C036	0.047 25 C C HL 1608	
C037	0.047 25 C C HL 1608	
C038	0.047 25 C C HL 1608	
C039	0.047 25 C C HL 1608	
C040	0.047 25 C C HL 1608	
C041	0.047 25 C C HL 1608	
C042	0.047 25 C C HL 1608	
C043	0.047 25 C C HL 1608	
C044	0.047 25 C C HL 1608	
C045	0.047 25 C C HL 1608	
C046	0.047 25 C C HL 1608	
C047	0.047 25 C C HL 1608	
C048	0.047 25 C C HL 1608	
C049	0.047 25 C C HL 1608	
C050	0.047 25 C C HL 1608	
C051	0.047 25 C C HL 1608	
C052	0.047 25 C C HL 1608	
C053	0.047 25 C C HL 1608	
C054	0.047 25 C C HL 1608	
C055	0.047 25 C C HL 1608	
C056	0.047 25 C C HL 1608	
C057	0.047 25 C C HL 1608	
C058	0.047 25 C C HL 1608	
C059	0.047 25 C C HL 1608	
C060	0.047 25 C C HL 1608	
C061	0.047 25 C C HL 1608	
C062	0.047 25 C C HL 1608	
C063	0.047 25 C C HL 1608	
C064	0.047 25 C C HL 1608	
C065	0.047 25 C C HL 1608	
C066	0.047 25 C C HL 1608	
C067	0.047 25 C C HL 1608	
C068	0.047 25 C C HL 1608	
C069	0.047 25 C C HL 1608	
C070	0.047 25 C C HL 1608	
C071	0.047 25 C C HL 1608	
C072	0.047 25 C C HL 1608	
C073	0.047 25 C C HL 1608	
C074	0.047 25 C C HL 1608	
C075	0.047 25 C C HL 1608	
C076	0.047 25 C C HL 1608	
C077	0.047 25 C C HL 1608	
C078	0.047 25 C C HL 1608	
C079	0.047 25 C C HL 1608	
C080	0.047 25 C C HL 1608	
C081	0.047 25 C C HL 1608	
C082	0.047 25 C C HL 1608	
C083	0.047 25 C C HL 1608	
C084	0.047 25 C C HL 1608	
C085	0.047 25 C C HL 1608	
C086	0.047 25 C C HL 1608	
C087	0.047 25 C C HL 1608	
C088	0.047 25 C C HL 1608	
C089	0.047 25 C C HL 1608	
C090	0.047 25 C C HL 1608	
C091	0.047 25 C C HL 1608	
C092	0.047 25 C C HL 1608	
C093	0.047 25 C C HL 1608	
C094	0.047 25 C C HL 1608	
C095	0.047 25 C C HL 1608	
C096	0.047 25 C C HL 1608	
C097	0.047 25 C C HL 1608	
C098	0.047 25 C C HL 1608	
C099	0.047 25 C C HL 1608	
C100	0.047 25 C C HL 1608	

LEDS

MARK	MODEL	REMARK
L001	LT1067A	C HIC RED
L002	LT1067A	C HIC RED
L003	10X5-2012A1	A M
L004	10X03615-03171	A M
L801	T002	H M
L802	FR401MA450	A M
L803	CN04	A M
L804	CN137	A M
L901	BL10FN1	A M
L902	JUMPER	A M
L903	JUMPER	A M
L904	JUMPER	A M
L905	JUMPER	A M
L906	JUMPER	A M
L907	JUMPER	A M
L908	JUMPER	A M
L909	JUMPER	A M
L910	JUMPER	A M
L911	JUMPER	A M
L912	JUMPER	A M
L913	JUMPER	A M
L914	JUMPER	A M
L915	JUMPER	A M
L916	JUMPER	A M
L917	JUMPER	A M
L918	JUMPER	A M
L919	JUMPER	A M
L920	JUMPER	A M
L921	JUMPER	A M
L922	JUMPER	A M
L923	JUMPER	A M
L924	JUMPER	A M
L925	JUMPER	A M
L926	JUMPER	A M
L927	JUMPER	A M
L928	JUMPER	A M
L929	JUMPER	A M
L930	JUMPER	A M
L931	JUMPER	A M
L932	JUMPER	A M
L933	JUMPER	A M
L934	JUMPER	A M
L935	JUMPER	A M
L936	JUMPER	A M
L937	JUMPER	A M
L938	JUMPER	A M
L939	JUMPER	A M
L940	JUMPER	A M
L941	JUMPER	A M
L942	JUMPER	A M
L943	JUMPER	A M
L944	JUMPER	A M
L945	JUMPER	A M
L946	JUMPER	A M
L947	JUMPER	A M
L948	JUMPER	A M
L949	JUMPER	A M
L950	JUMPER	A M
L951	JUMPER	A M
L952	JUMPER	A M
L953	JUMPER	A M
L954	JUMPER	A M
L955	JUMPER	A M
L956	JUMPER	A M
L957	JUMPER	A M
L958	JUMPER	A M
L959	JUMPER	A M
L960	JUMPER	A M
L961	JUMPER	A M
L962	JUMPER	A M
L963	JUMPER	A M
L964	JUMPER	A M
L965	JUMPER	A M
L966	JUMPER	A M
L967	JUMPER	A M
L968	JUMPER	A M
L969	JUMPER	A M
L970	JUMPER	A M
L971	JUMPER	A M
L972	JUMPER	A M
L973	JUMPER	A M
L974	JUMPER	A M
L975	JUMPER	A M
L976	JUMPER	A M
L977	JUMPER	A M
L978	JUMPER	A M
L979	JUMPER	A M
L980	JUMPER	A M
L981	JUMPER	A M
L982	JUMPER	A M
L983	JUMPER	A M
L984	JUMPER	A M
L985	JUMPER	A M
L986	JUMPER	A M
L987	JUMPER	A M
L988	JUMPER	A M
L989	JUMPER	A M
L990	JUMPER	A M
L991	JUMPER	A M
L992	JUMPER	A M
L993	JUMPER	A M
L994	JUMPER	A M
L995	JUMPER	A M
L996	JUMPER	A M
L997	JUMPER	A M
L998	JUMPER	A M
L999	JUMPER	A M
L1000	JUMPER	A M

ZENER DIODES

MARK	MODEL	REMARK
Z0101	5.1V	A M
Z0102	5.1V	A M
Z0103	5.1V	A M
Z0104	5.1V	A M
Z0105	5.1V	A M
Z0106	5.1V	A M
Z0107	5.1V	A M
Z0108	5.1V	A M
Z0109	5.1V	A M
Z0110	5.1V	A M
Z0111	5.1V	A M
Z0112	5.1V	A M
Z0113	5.1V	A M
Z0114	5.1V	A M
Z0115	5.1V	A M
Z0116	5.1V	A M
Z0117	5.1V	A M
Z0118	5.1V	A M
Z0119	5.1V	A M
Z0120	5.1V	A M
Z0121	5.1V	A M
Z0122	5.1V	A M
Z0123	5.1V	A M
Z0124	5.1V	A M
Z0125	5.1V	A M
Z0126	5.1V	A M
Z0127	5.1V	A M
Z0128	5.1V	A M
Z0129	5.1V	A M
Z0130	5.1V	A M
Z0131	5.1V	A M
Z0132	5.1V	A M
Z0133	5.1V	A M
Z0134	5.1V	A M
Z0135	5.1V	A M
Z0136	5.1V	A M
Z0137	5.1V	A M
Z0138	5.1V	A M
Z0139	5.1V	A M
Z0140	5.1V	A M
Z0141	5.1V	A M
Z0142	5.1V	A M
Z0143	5.1V	A M
Z0144	5.1V	A M
Z0145	5.1V	A M
Z0146	5.1V	A M
Z0147	5.1V	A M
Z0148	5.1V	A M
Z0149	5.1V	A M
Z0150	5.1V	A M
Z0151	5.1V	A M
Z0152	5.1V	A M
Z0153	5.1V	A M
Z0154	5.1V	A M
Z0155	5.1V	A M
Z0156	5.1V	A M
Z0157	5.1V	A M
Z0158	5.1V	A M
Z0159	5.1V	A M
Z0160	5.1V	A M
Z0161	5.1V	A M
Z0162	5.1V	A M
Z0163	5.1V	A M
Z0164	5.1V	A M
Z0165	5.1V	A M
Z0166	5.1V	A M
Z0167	5.1V	A M
Z0168	5.1V	A M
Z0169	5.1V	A M
Z0170	5.1V	A M
Z0171	5.1V	A M
Z0172	5.1V	A M
Z0173	5.1V	A M
Z0174	5.1V	A M
Z0175	5.1V	A M
Z0176	5.1V	A M
Z0177	5.1V	A M
Z0178	5.1V	A M
Z0179	5.1V	A M
Z0180	5.1V	A M
Z0181	5.1V	A M
Z0182	5.1V	A M
Z0183	5.1V	A M
Z0184	5.1V	A M
Z0185	5.1V	A M
Z0186	5.1V	A M
Z0187	5.1V	A M
Z0188	5.1V	A M
Z0189	5.1V	A M
Z0190	5.1V	A M
Z0191	5.1V	A M
Z0192	5.1V	A M
Z0193	5.1V	A M
Z0194	5.1V	A M
Z0195	5.1V	A M
Z0196	5.1V	A M
Z0197	5.1V	A M
Z0198	5.1V	A M
Z0199	5.1V	A M
Z0200	5.1V	A M
Z0201	5.1V	A M
Z0202	5.1V	A M
Z0203	5.1V	A M
Z0204	5.1V	A M
Z0205	5.1V	A M
Z0206	5.1V	A M
Z0207	5.1V	A M
Z0208	5.1V	A M
Z0209	5.1V	A M
Z0210	5.1V	A M
Z0211	5.1V	A M
Z0212	5.1V	A M
Z0213	5.1V	A M
Z0214	5.1V	A M
Z0215	5.1V	A M
Z0216	5.1V	A M
Z0217	5.1V	A M
Z0218	5.1V	A M
Z0219	5.1V	A M
Z0220	5.1V	A M
Z0221	5.1V	A M
Z0222	5.1V	A M
Z0223	5.1V	A M

PRINTED WIRING BOARD LOCATION DIAGRAM

MODEL RAI-25NH4, RAI-40NH4

MAIN P.W.B.

Marking on P.W.B.

COMPONENT SIDE

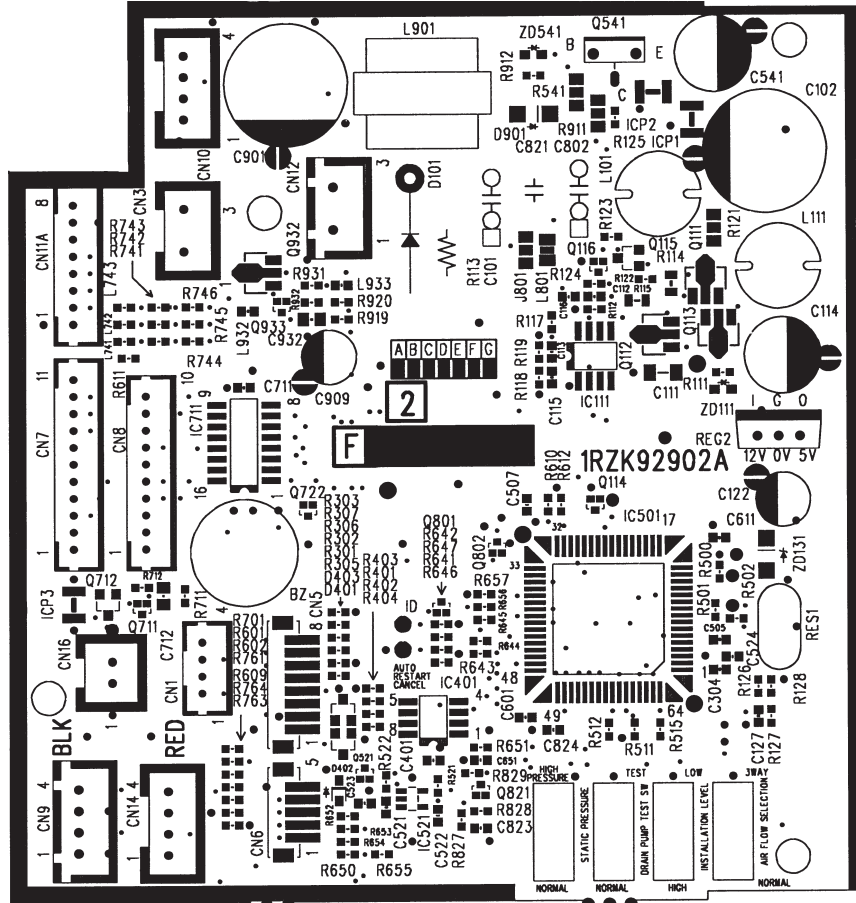

SOLDERING SIDE

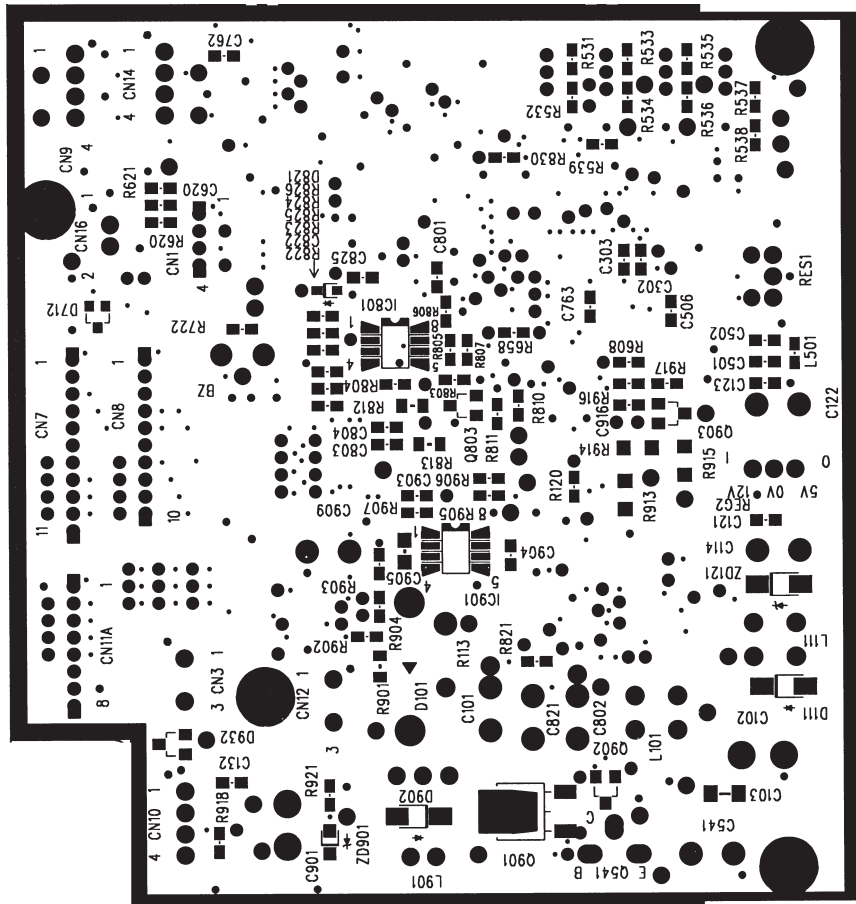

MODEL RAC-25NH4, RAC-50NH4

MAIN P.W.B. Marking on P.W.B

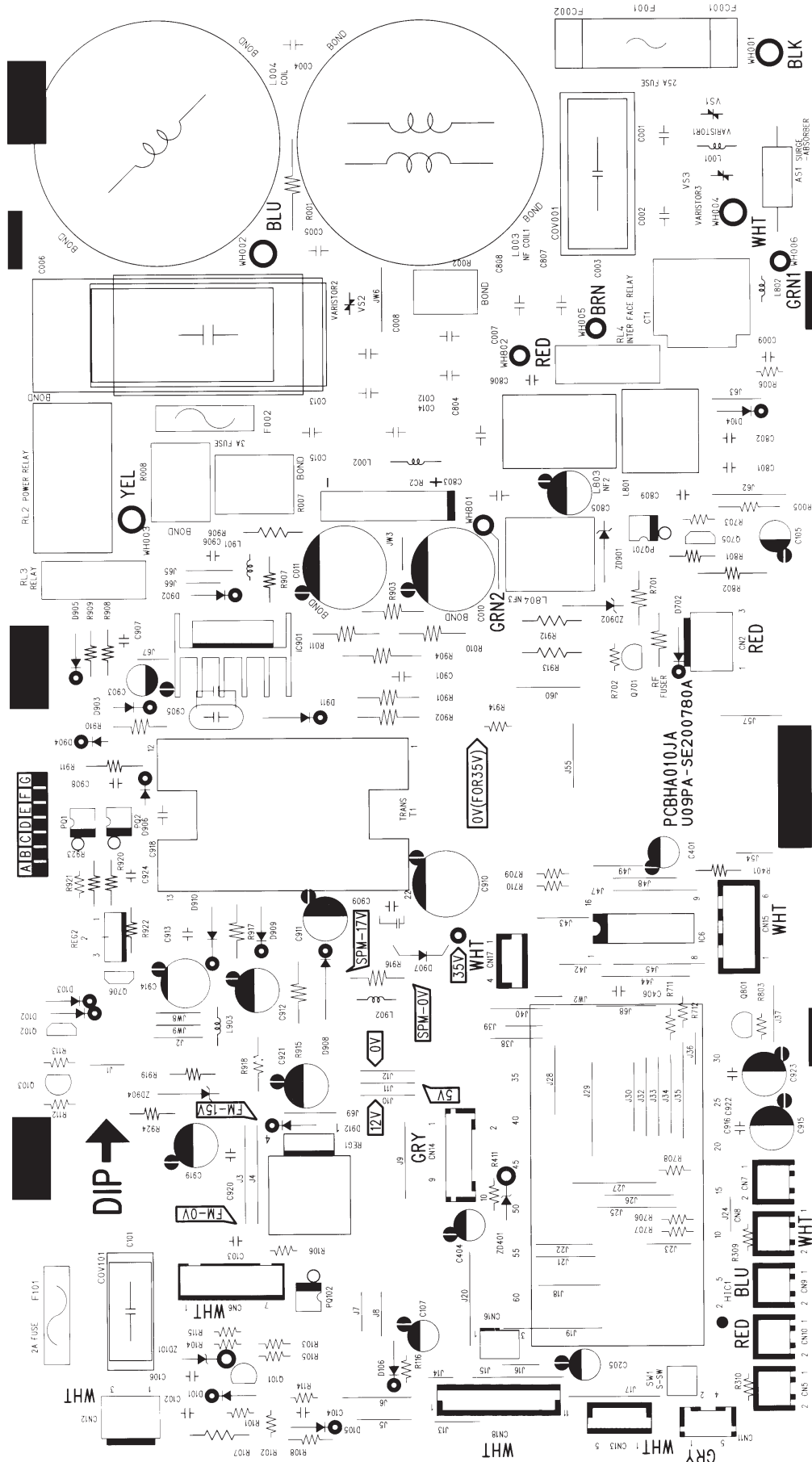

COMPONENT SIDE

BLOCK DIAGRAM

MODEL RAI-25NH4 / RAC-25NH4
RAI-40NH4 / RAC-50NH4

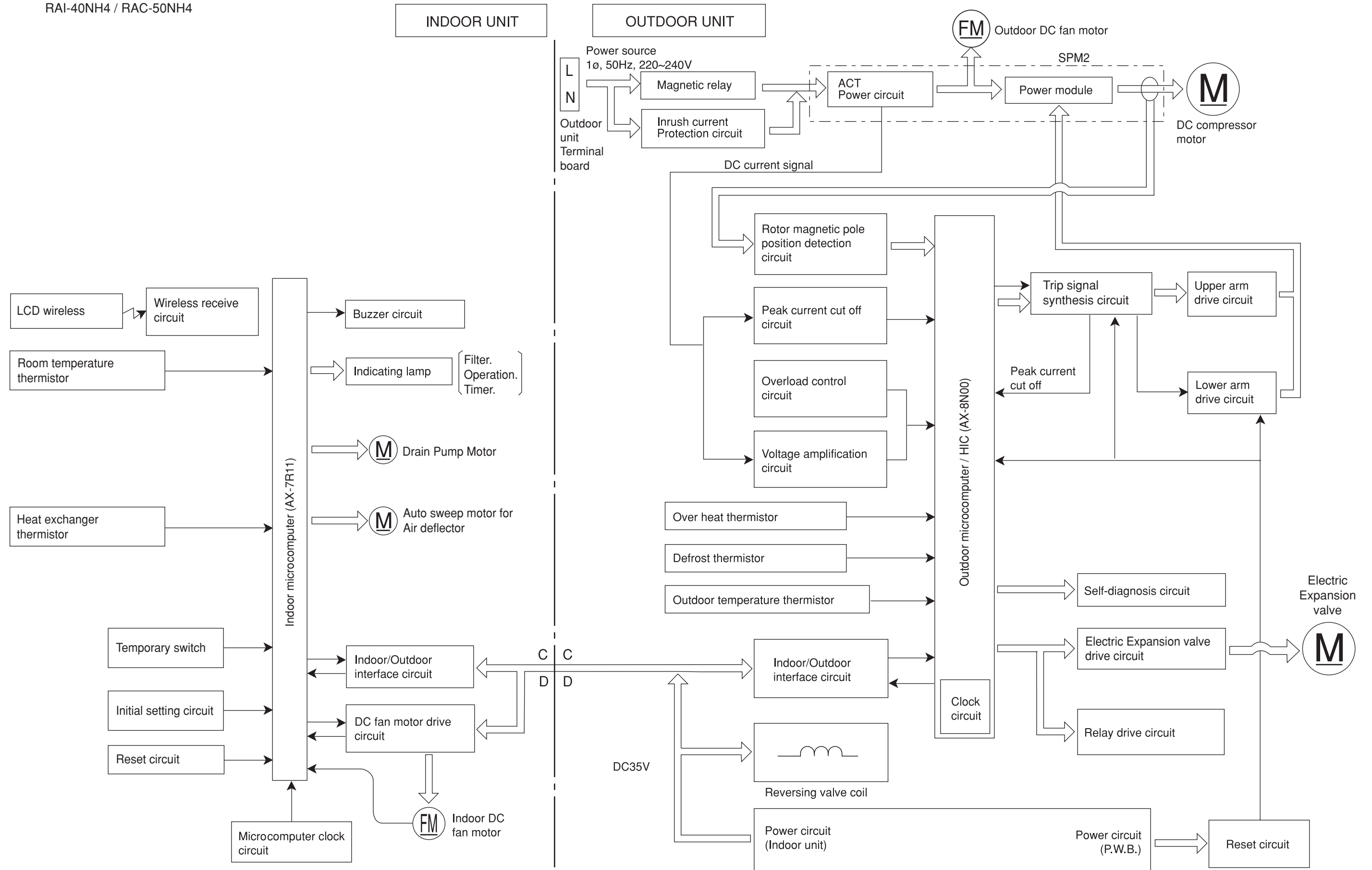

BASIC MODE

MODEL RAI-25NH4, RAI-40NH4

Operation mode	Fan	Cooling	Dehumidifying (dehumidifying operation by the function select button only, not including that engaged by the dehumidify button)	Heating	Auto										
Basic operation of start/stop switch															
Timer functions	Off-timer														
	On-timer														
	Off -> On On -> Off timer														
Fan speed mode (indoor fan)	Auto	<p>Changes from "Hi" to "Med" or "Lo" depending on room temperature.</p> <p>1. Runs at "Hi" until first thermo off after operation is started. 2. Runs at "Lo" when thermo is off.</p>	<p>Changes between "Lo" and "Med" depending on the room temperature.</p> <table border="1"> <thead> <tr> <th>Temperature division</th> <th>Fan speed</th> </tr> </thead> <tbody> <tr> <td>Division 1</td> <td>Lo</td> </tr> <tr> <td>Division 2</td> <td>Lo</td> </tr> <tr> <td>Division 3</td> <td>Med</td> </tr> <tr> <td>Division 4</td> <td>Med</td> </tr> </tbody> </table> <p>1. The indoor fan also stops when the compressor is in stop status.</p>	Temperature division	Fan speed	Division 1	Lo	Division 2	Lo	Division 3	Med	Division 4	Med	<p>Set to "ultra-Lo", "Lo", "Med", "Hi", "ultra-Hi" or "stop" depending on the room temperature, time and heat exchange temperature. Set to "stop" if the room temperature is 18°C in the "ultra-Lo" mode other than during preheating (cooling is recovered at 18.33°C).</p> <p>When the compressor is running at maximum speed during hot dash or when recovered from defrosting, In modes other than left</p>	<p>Operating mode is judged by room temperature and outdoor temperature.</p> <p>(1) Judging by outdoor temperature</p> <ul style="list-style-type: none"> Operating mode is judged by outdoor temperature. Only when the mode is not restricted by this judgment, the judgment by room temperature in the next paragraph will be performed. (a) Outdoor temperature $\geq 30^\circ\text{C}$: Restricted to cooling (b) Outdoor temperature $\leq 9^\circ\text{C}$: Restricted to heating <p>(2) Judging by room temperature</p> <p>Operating mode at start up is judged (initial judgment)</p> <p>(a) Conditions for judgment (any of the followings)</p> <ul style="list-style-type: none"> When auto operation is started after 1 hour has elapsed since the operation was stopped. When auto operation is started after the previous manual mode operation. When the operating mode is switched to auto while operating at manual mode. <p>(b) Judging method</p> <ul style="list-style-type: none"> Room temperature $\geq 23^\circ\text{C} \pm 3^\circ\text{C}$: Cooling Room temperature $< 23^\circ\text{C} \pm 3^\circ\text{C}$: Heating * $\pm 3^\circ\text{C}$ is the fine adjustment value from the remote controller. <p>Judging operating mode change during operation (Continuous judgment)</p> <p>(a) Conditions for judgment (any of the followings)</p> <ul style="list-style-type: none"> The mode is reviewed at every interval time. When auto operation is started again before 1 hour has elapsed since the operation was stopped. <p>(b) Judging method</p> <ul style="list-style-type: none"> Judge by setting the hysteresis on the final preset temperature. The final preset temperature is the actually targeted preset temperature which is the sum of the basic preset temperature and each type of shift value (e.g. $\pm 3^\circ\text{C}$ by remote controller, preset temperature correction value, powerful shift value, etc.). <p>[Currently cooling]</p> <ul style="list-style-type: none"> Room temperature \leq Final preset temperature -3°C Change to heating Room temperature $>$ Final preset temperature -3°C Continue cooling <p>[Currently heating]</p> <ul style="list-style-type: none"> Room temperature \geq Final preset temperature $+2^\circ\text{C}$ Change to cooling Room temperature $<$ Final preset temperature $+2^\circ\text{C}$ Continue heating
	Temperature division	Fan speed													
	Division 1	Lo													
	Division 2	Lo													
Division 3	Med														
Division 4	Med														
Hi	Operates at "Hi" regardless of the room temperature.	Set to "ultra-Hi" when the compressor runs at maximum speed, and to "Hi" in other modes.	Set to "Hi" in modes other than when the compressor stops.	Set to "ultra-Lo", "Lo", "Med", "Hi", "ultra-Hi" or "stop" depending on the room temperature, and time. Set to "stop" if the room temperature is 18°C in the "ultra-Lo" mode other than during preheating (cooling is recovered at 18.33°C). Set to "ultra-Hi" when the compressor is running at maximum speed during hot dash or when recovered from defrosting.											
Med	Operates at "Med" regardless of the room temperature.	Same as at left.	Set to "Med" in modes other than when the compressor stops.	Set to "ultra-Lo", "Lo", "Med" or "stop" depending on the room temperature and time. Set to "stop" if the room temperature is 18°C in the "ultra-Lo" mode other than during preheating (cooling is recovered at 18.33°C). The fan speed is controlled by the heat exchanger temperature; the overload control is executed as in the following diagram:											
Lo	Operates at "Lo" regardless of the room temperature.	Same as at left.	Set to "Lo" in modes other than when the compressor stops.	Set to "ultra-Lo", "Lo", or "stop" depending on the room temperature and time. Set to "stop" if the room temperature is 18°C in the "ultra-Lo" mode other than during preheating (cooling is recovered at 18.33°C). The fan speed is controlled by the heat exchanger temperature; the overload control is executed as in the following diagram:											
Basic operation of temperature controller	<p>Performs only fan operation at the set speed regardless of the room temperature.</p>	See page 49.	See page 53.	See page 55.											
Sleep operation (with sleep button ON)	<ul style="list-style-type: none"> Enters sleep operation after set as on the left. Action during sleep operation Lo (sleep) operation 	<ul style="list-style-type: none"> Same as at left See page 51. 	<ul style="list-style-type: none"> Same as at left See page 53. 	<ul style="list-style-type: none"> Same as at left See page 57. 	<ul style="list-style-type: none"> Same as at left. Performs the sleep operation of each operation mode. 										

Table 1 Mode data file

	RAI-25NH4	RAI-40NH4
LABEL NAME	VALUE	
WMAX	4400 min ⁻¹	6000 min ⁻¹
WMAX2	4500 min ⁻¹	6000 min ⁻¹
WSTD	3300 min ⁻¹	4250 min ⁻¹
WBEMAX	2800 min ⁻¹	3500 min ⁻¹
CMAX	2900 min ⁻¹	4700 min ⁻¹
CMAX2	3000 min ⁻¹	4700 min ⁻¹
CSTD	2350 min ⁻¹	4100 min ⁻¹
CKYMAX	2200 min ⁻¹	3500 min ⁻¹
CJKMAX	1800 min ⁻¹	2700 min ⁻¹
CBEMAX	1600 min ⁻¹	2000 min ⁻¹
WMIN	1500 min ⁻¹	1800 min ⁻¹
CMIN	1500 min ⁻¹	1800 min ⁻¹
STARTMC	60 Seconds	60 Seconds
DWNRATEW	80%	80%
DWNRATEC	80%	80%
SHIFTW	4.00°C	4.00°C
SHIFTC	-1.00°C	-2.99°C
CLMXTTP	30.00°C	30.00°C
YNEOF	21.00°C	21.00°C
TEION	2.00°C	2.00°C
TEIOF	6.00°C	6.00°C
SFTDSW	2.66°C	2.66°C
DFTIM1	50 Minutes	50 Minutes
DFTIM2	90 Minutes	90 Minutes
DFTIM3	60 Minutes	60 Minutes

Basic Cooling Operation

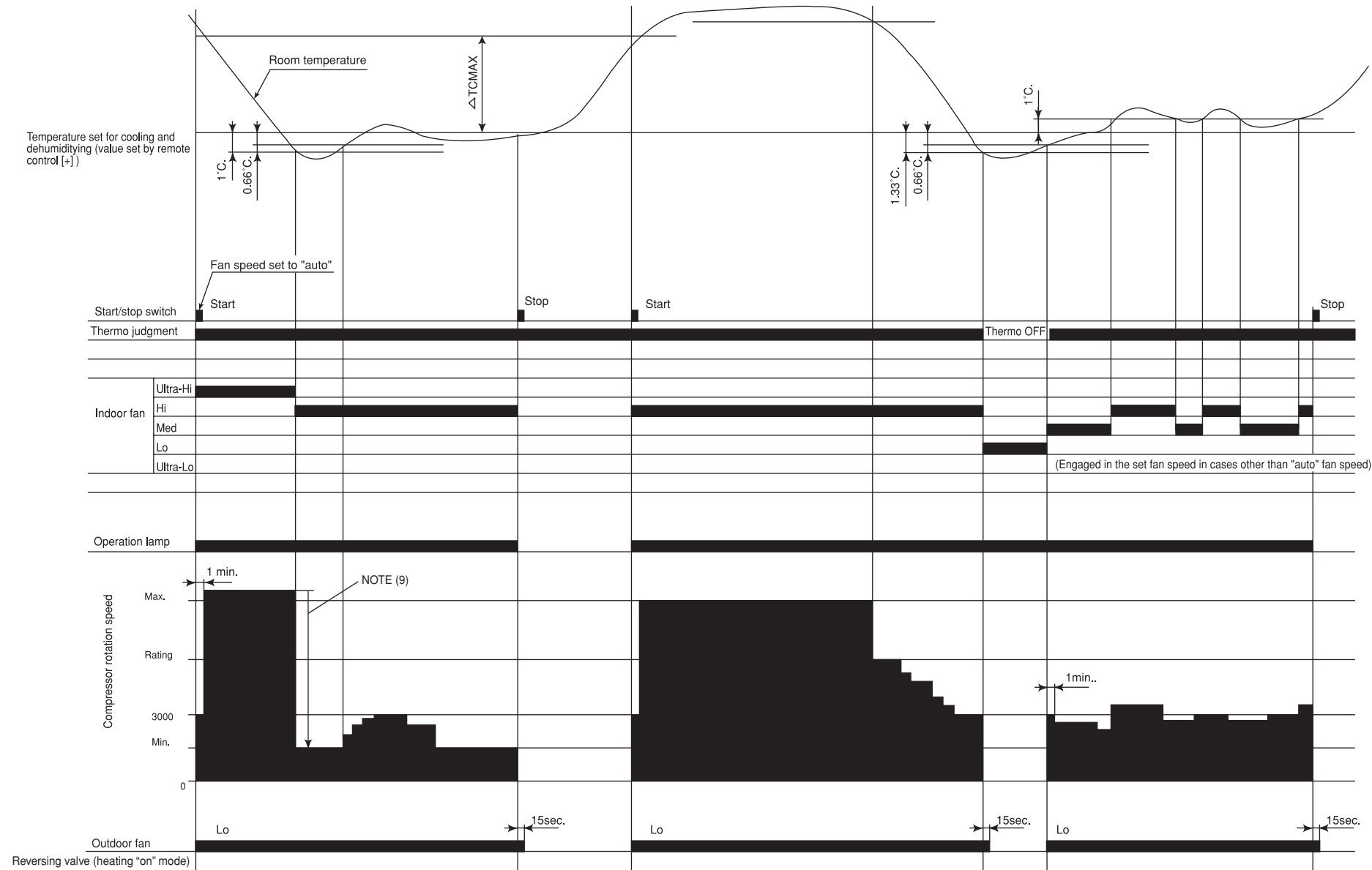

Notes:

- (1) Condition for entering into Cool Dashed mode. When fan set to "Hi" or "Auto mode" and temperature difference between indoor temperature and set temperature has a corresponding compressor rpm (calculated value in Table 7) larger than WMAX.
- (2) Cool Dashed will release when i) a maximum 25 minutes is lapsed and ii) room temperature is lower than set temperature -3°C (thermo off) and iii) when room temperature has achieved setting temperature -1°C then maximum Cool Dashed time will be revised to 20 minutes. And iv) indoor fan is set to Lo and Med fan mode and v) change operation mode.
- (3) During Cool Dashed operation, thermo off temperature is set temperature (with shift value) -3°C . After thermo off, operation continue in Fuzzy control mode.
- (4) Compressor minimum "ON" time and "OFF" time is 3 minutes.
- (5) During normal cooling mode, compressor maximum rpm CMAX will maintain for 60 minutes if indoor temperature is lower than CLMXTTP. No time constrain if indoor temperature is higher than CLMXTTP.
- (6) When fan is set to "Hi", compressor rpm will be limited to CKYMAX.
- (7) When fan is set to "Med", compressor rpm will be limited to CJKMAX.
- (8) When fan is set to "Lo", compressor rpm will be limited to CBEMAX.
- (9) During Cool Dashed, when room temperature reaches set temperature -1°C compressor rpm is actual rpm x DWRATEC.

Table 2 ΔTCMAX

Temperature difference	Calculated compressor rpm
1.66	2265 min^{-1}
2	2435 min^{-1}
2.33	2600 min^{-1}
2.66	2765 min^{-1}
3	2935 min^{-1}
3.33	3100 min^{-1}
3.66	3265 min^{-1}
4	3435 min^{-1}
4.33	3600 min^{-1}
4.66	3765 min^{-1}
5	3935 min^{-1}
5.33	4100 min^{-1}
5.66	4265 min^{-1}
6	4435 min^{-1}
6.33	4600 min^{-1}
6.66	4765 min^{-1}
7	4935 min^{-1}
7.33	5100 min^{-1}
7.66	5265 min^{-1}
8	5435 min^{-1}
8.33	5600 min^{-1}
8.66	5765 min^{-1}
9	5935 min^{-1}
9.33	6100 min^{-1}
9.66	6265 min^{-1}
10	6435 min^{-1}
10.33	6600 min^{-1}
10.66	6765 min^{-1}
11	6935 min^{-1}

Note:

1. See the data in Table 1 on page 45 for each constant in capital letters in the diagrams.

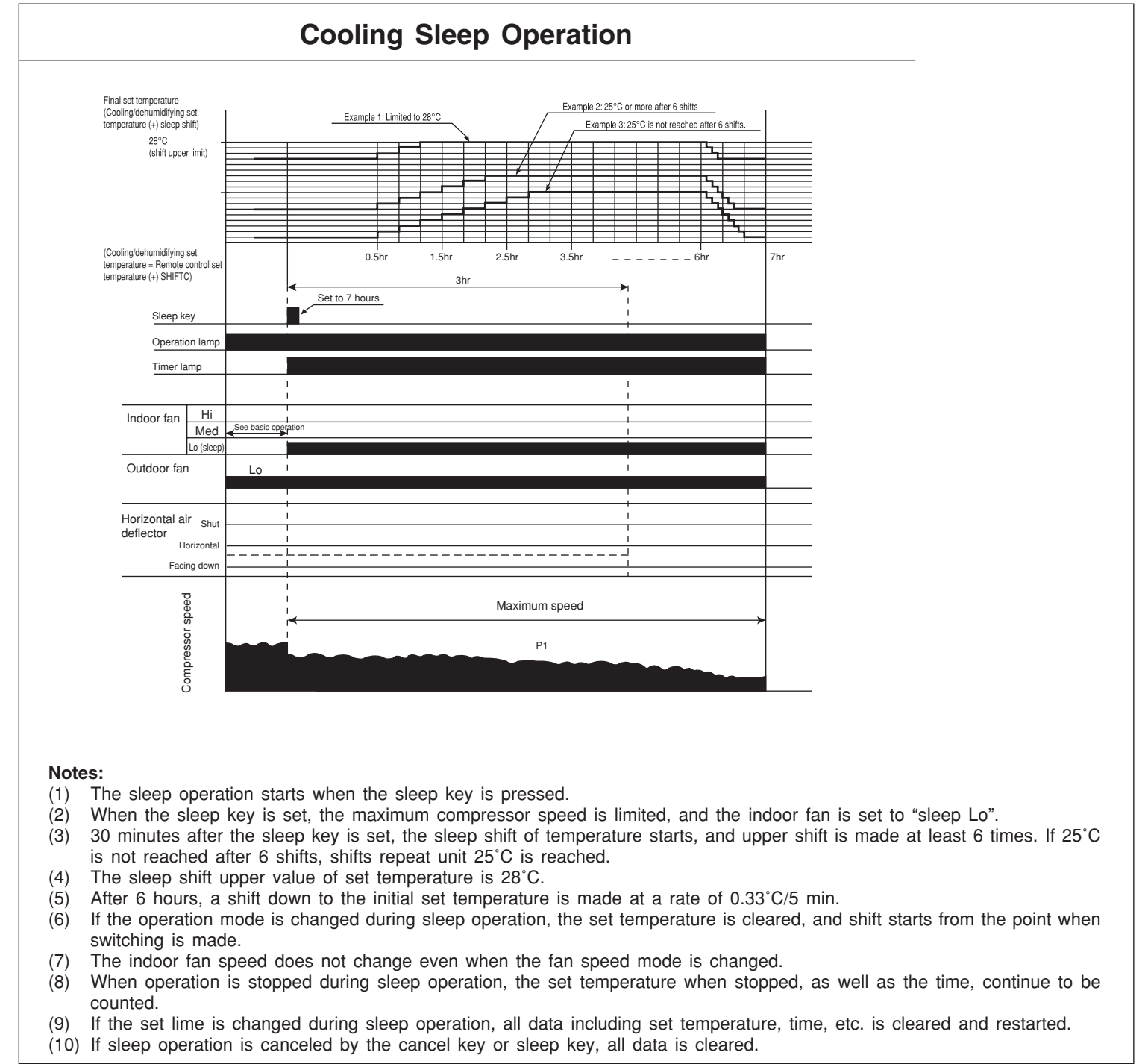
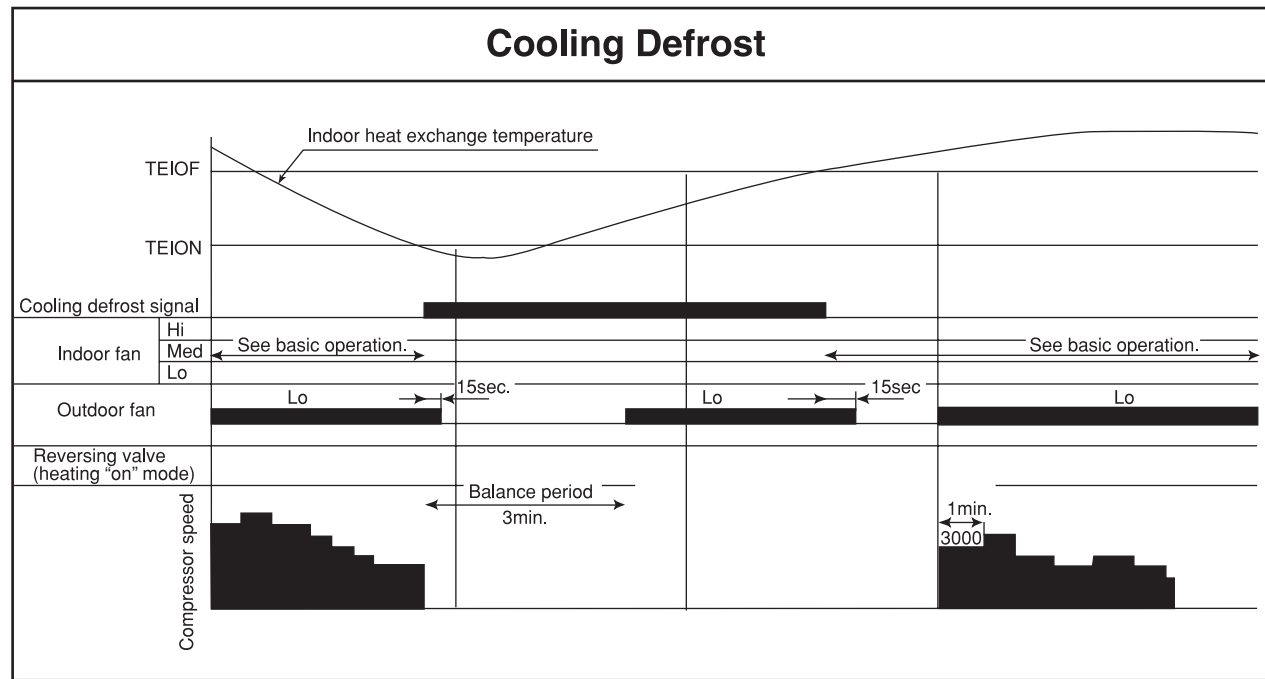

Notes:

- (1) The sleep operation starts when the sleep key is pressed.
- (2) When the sleep key is set, the maximum compressor speed is limited, and the indoor fan is set to "sleep Lo".
- (3) 30 minutes after the sleep key is set, the sleep shift of temperature starts, and upper shift is made at least 6 times. If 25°C is not reached after 6 shifts, shifts repeat until 25°C is reached.
- (4) The sleep shift upper value of set temperature is 28°C.
- (5) After 6 hours, a shift down to the initial set temperature is made at a rate of 0.33°C/5 min.
- (6) If the operation mode is changed during sleep operation, the set temperature is cleared, and shift starts from the point when switching is made.
- (7) The indoor fan speed does not change even when the fan speed mode is changed.
- (8) When operation is stopped during sleep operation, the set temperature when stopped, as well as the time, continue to be counted.
- (9) If the set time is changed during sleep operation, all data including set temperature, time, etc. is cleared and restarted.
- (10) If sleep operation is canceled by the cancel key or sleep key, all data is cleared.

Dehumidifying

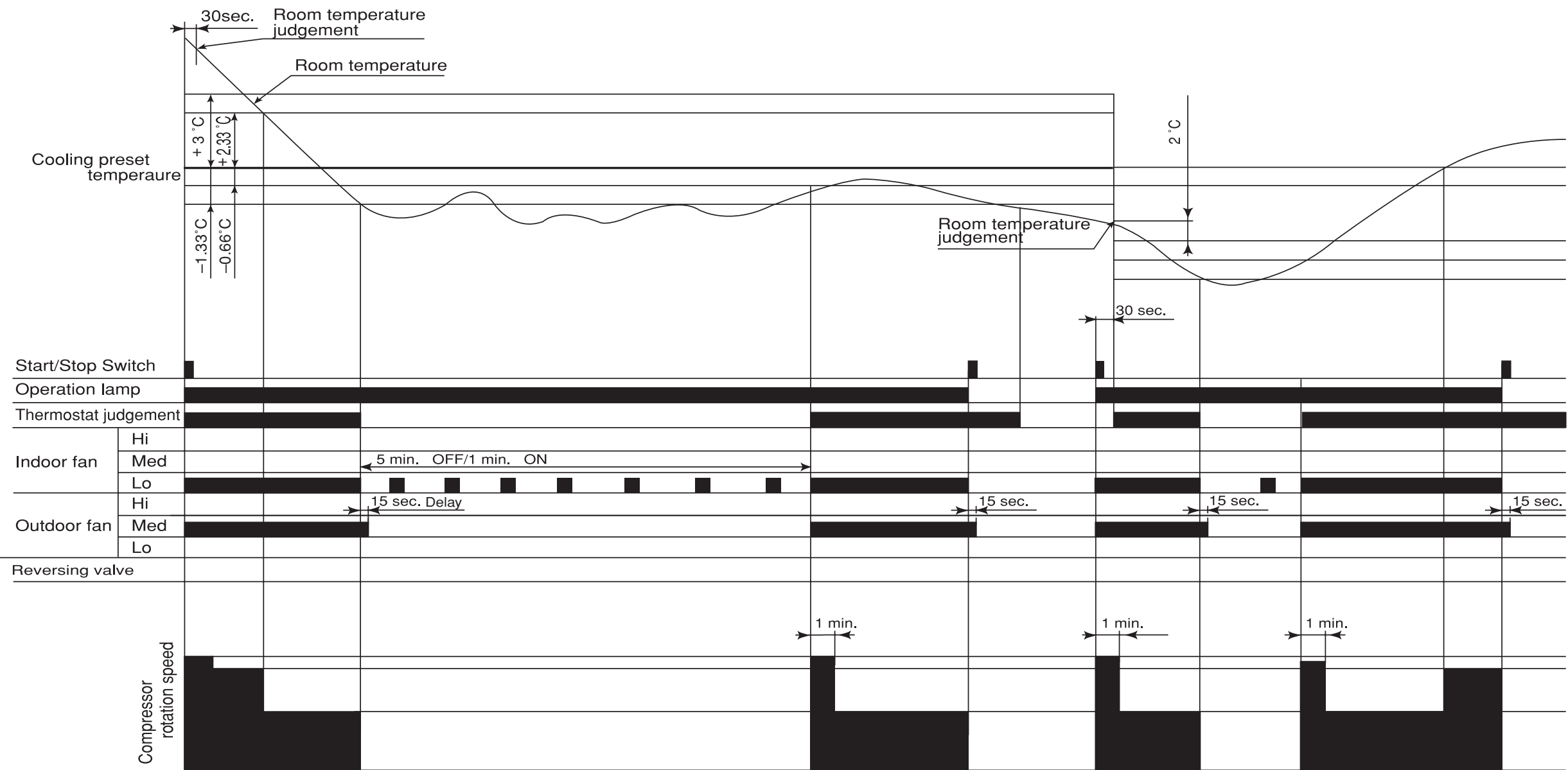

Notes:

- (1) If the room temperature is (cooling preset temperature) - (1.33°C) or less after 30 seconds from starting the operation, the operation is done assuming as the preset temperature = (room temperature at the time) - (2°C).
- (2) The indoor fan is operated in the "Lo" mode. During thermo OFF indoor fan will be OFF for 5 minutes and ON for 1 minute.
- (3) When the operation is started by the thermostat turning ON, the start of the indoor fan is delayed 32 seconds after the start of compressor operation.
- (4) The compressor is operated forcedly for 3 minutes after operation is started.
- (5) The minimum ON time and OFF time of the compressor are 3 minutes.

Basic Heating Operation

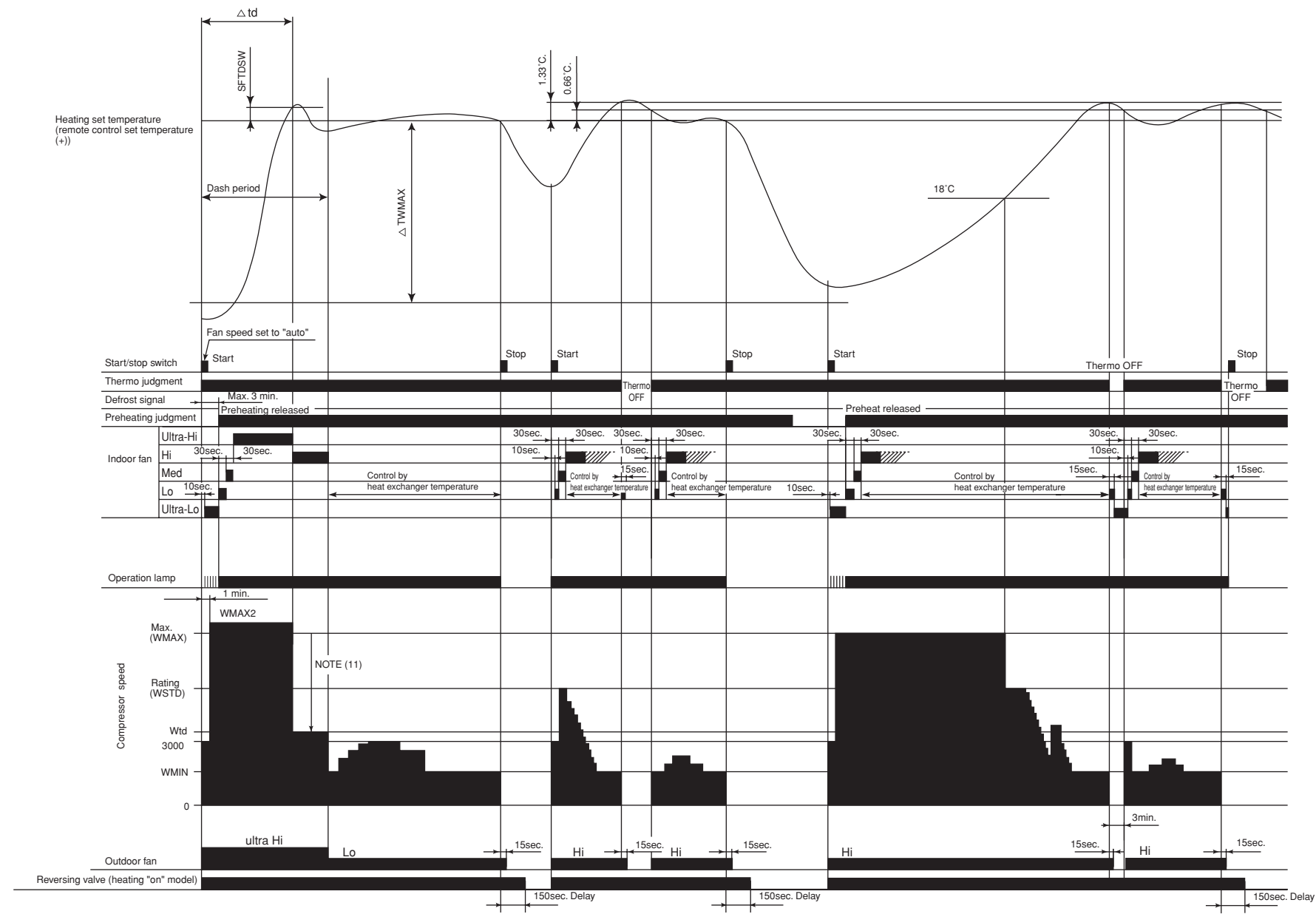

Notes:

- (1) Condition for entering into Hot Dashed mode. When fan set to “Hi” or “Auto mode” and i) Indoor temperature is lower than 18°C, and ii) outdoor temperature is lower than 10°C, and iii) Temperature difference between indoor temperature and set temperature has a corresponding compressor rpm (calculated value in Table 3) larger than WMAX.
- (2) Hot Dashed will release when i) Room temperature has achieved the set temperature + SFTDSW. ii) Thermo off.
- (3) During Hot Dashed operation, thermo off temperature is set temperature (with shift value) +3°C. After thermo off, operation continue in Fuzzy control mode.
- (4) Compressor minimum “ON” time and “OFF” time is 3 minutes.
- (5) During normal heating mode, compressor maximum rpm WMAX will maintain for 120 minutes if indoor temperature is higher than 18°C. No time limit constrain if indoor temperature is lower than 18°C and outdoor temperature is lower than 2°C.
- (6) During Hotkeep or Defrost mode, indoor operation lamp will blink at interval of 3 seconds “ON” and 0.5 second “OFF”.
- (7) When heating mode starts, it will enter into Hotkeep mode if indoor heat exchanger temperature is lower than YNEOF + 0.33°C.
- (8) When fan is set to “Med” or “Lo”, compressor rpm will be limited to WBEMAX.
- (9) In “Ultra-Lo” fan mode, if indoor temperature is lower than 18°C, indoor fan will stop. If indoor temperature is higher than 18°C + 0.33°C, fan will continue in “Ultra-Lo” mode. During Hotkeep or Defrost mode, fan will continue in “Ultra-Lo” mode.
- (10) During Hot Dashed or outdoor temperature is lower than -5°C, compressor rpm is WMAX2.
- (11) During Hot Dashed, when room temperature reaches set temperature + SFTDSW compressor rpm is actual rpm x DWNRATEW.

Table 3 ΔTWMAX

Temperature difference	Calculated compressor rpm
1.66	1965 min ⁻¹
2	2135 min ⁻¹
2.33	2300 min ⁻¹
2.66	2465 min ⁻¹
3	2635 min ⁻¹
3.33	2800 min ⁻¹
3.66	2965 min ⁻¹
4	3135 min ⁻¹
4.33	3300 min ⁻¹
4.66	3465 min ⁻¹
5	3635 min ⁻¹
5.33	3800 min ⁻¹
5.66	3965 min ⁻¹
6	4135 min ⁻¹
6.33	4300 min ⁻¹
6.66	4465 min ⁻¹
7	4635 min ⁻¹
7.33	4800 min ⁻¹
7.66	4965 min ⁻¹
8	5135 min ⁻¹
8.33	5300 min ⁻¹
8.66	5465 min ⁻¹
9	5635 min ⁻¹
9.33	5800 min ⁻¹
9.66	5965 min ⁻¹
10	6135 min ⁻¹
10.33	6300 min ⁻¹
10.66	6465 min ⁻¹
11	6635 min ⁻¹

Notes:

1. See the data in Table 1 on page 47 for each constant in capital letters in the diagrams.

Reversing Valve Defrosting

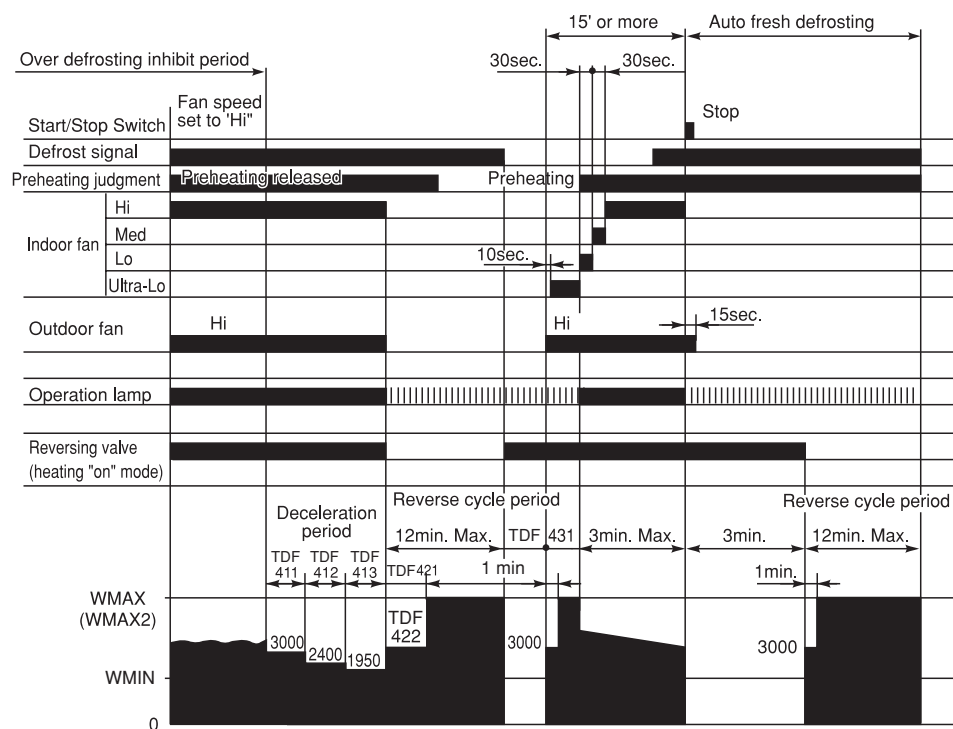

Notes:

- (1) The defrosting inhibit period is set as shown in the diagram below. When defrosting has finished once, the inhibit period is newly set, based on the outdoor temperature when the compressor was started. During this period, the defrost signal is not accepted.
- (2) If the difference between the room and outdoor temperature is large when defrosting is finished, the maximum compressor speed (WMAX) or (WMAX2) can be continued for 120 minutes maximum.
- (3) The defrosting period is 12 minutes maximum.
- (4) When operation is stopped during defrosting, it is switched to auto refresh defrosting.
- (5) Auto refresh defrosting cannot be engaged within 15 minutes after operation is started or defrosting is finished.

Setting Defrosting Inhibit Period

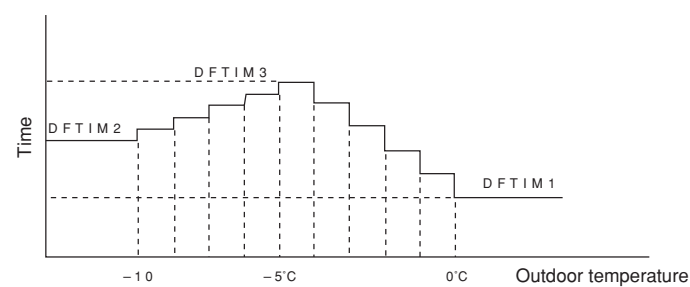

Notes:

- (1) The first inhibit time after operation start is set to DFTIM1.
- (2) From the second time onwards, the inhibit time is set according to the time required for defrosting.
Reverse cycle operation time \geq [DEFCOL] : DFTIM1 is set.
Reverse cycle operation time $<$ [DEFCOL] : The time corresponding to outdoor temperature is set.

Heating Sleep Operation

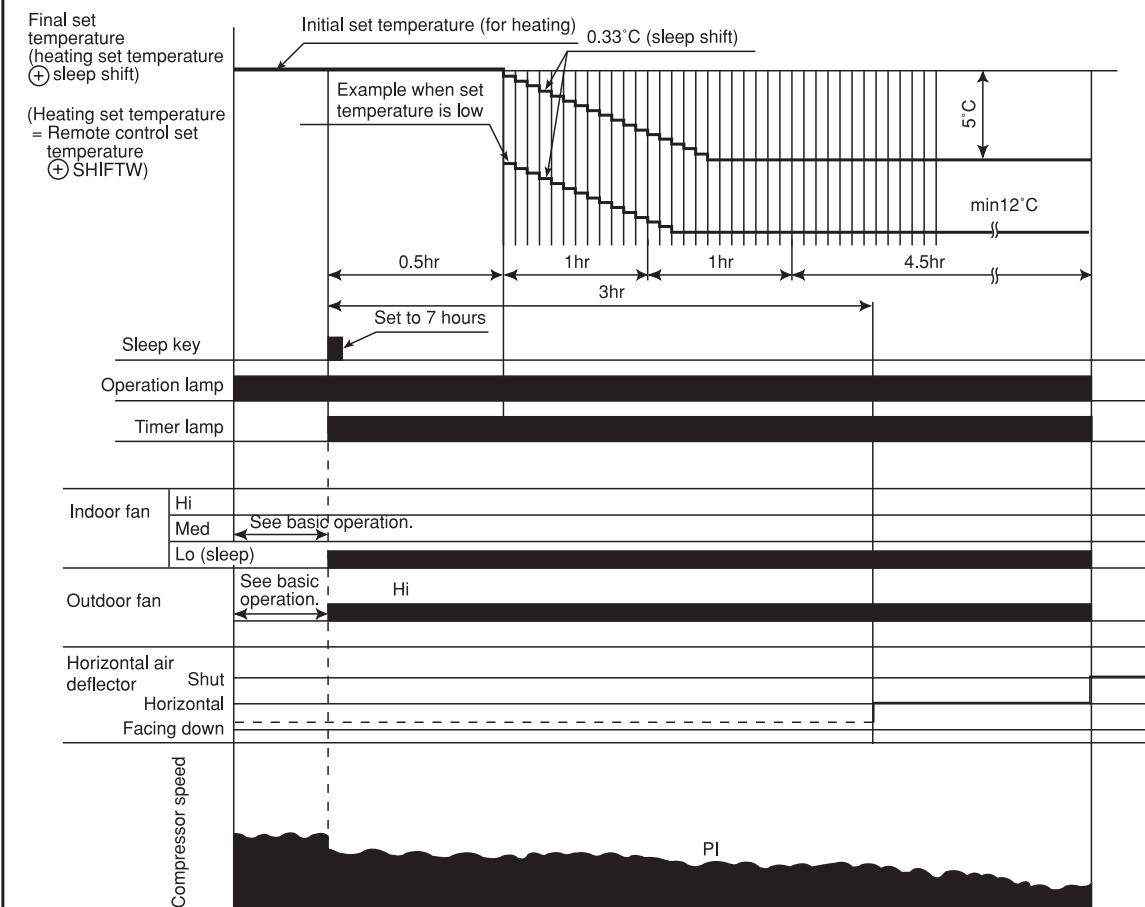

Notes:

- (1) The sleep operation starts when the sleep key is pressed.
- (2) When the sleep key is set, the maximum compressor speed is limited to WSTD+2000/2, and the indoor fan is set to "sleep Lo".
- (3) 30 minutes after the sleep key is set, the sleep shift of set temperature starts.
- (4) The maximum sleep shift of set temperature is 5°C, and the minimum is 12°C.
- (5) If the operation mode is changed during sleep operation, the changed operation mode is set and sleep control starts.
- (6) The indoor fan speed does not change even when the fan speed mode is changed. (Lo)
- (7) When defrosting is to be set during sleep operation, defrosting is engaged and sleep operation is restored after defrosting.
- (8) When operation is stopped during sleep operation, the set temperature when stopped, as well as the time, continue to be counted.
- (9) If the set time is changed during sleep operation, all data including set temperature, time, etc. is cleared and restarted.
- (10) If sleep operation is canceled by the cancel key or sleep key, all data is cleared.

REFRIGERATING CYCLE DIAGRAM

MODEL RAI-25NH4

RAC-25NH4

COOLING, DEHUMIDIFYING, DEFROSTING

OUTDOOR UNIT

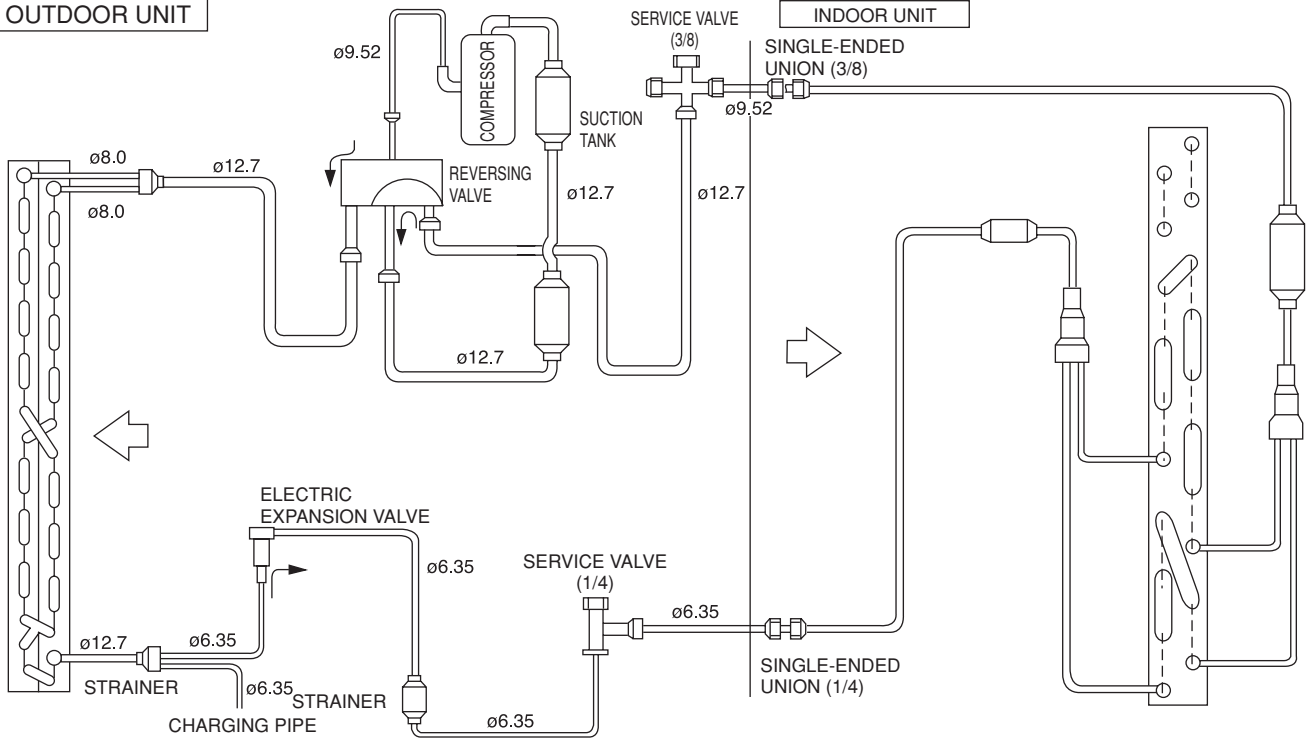

HEATING

OUTDOOR UNIT

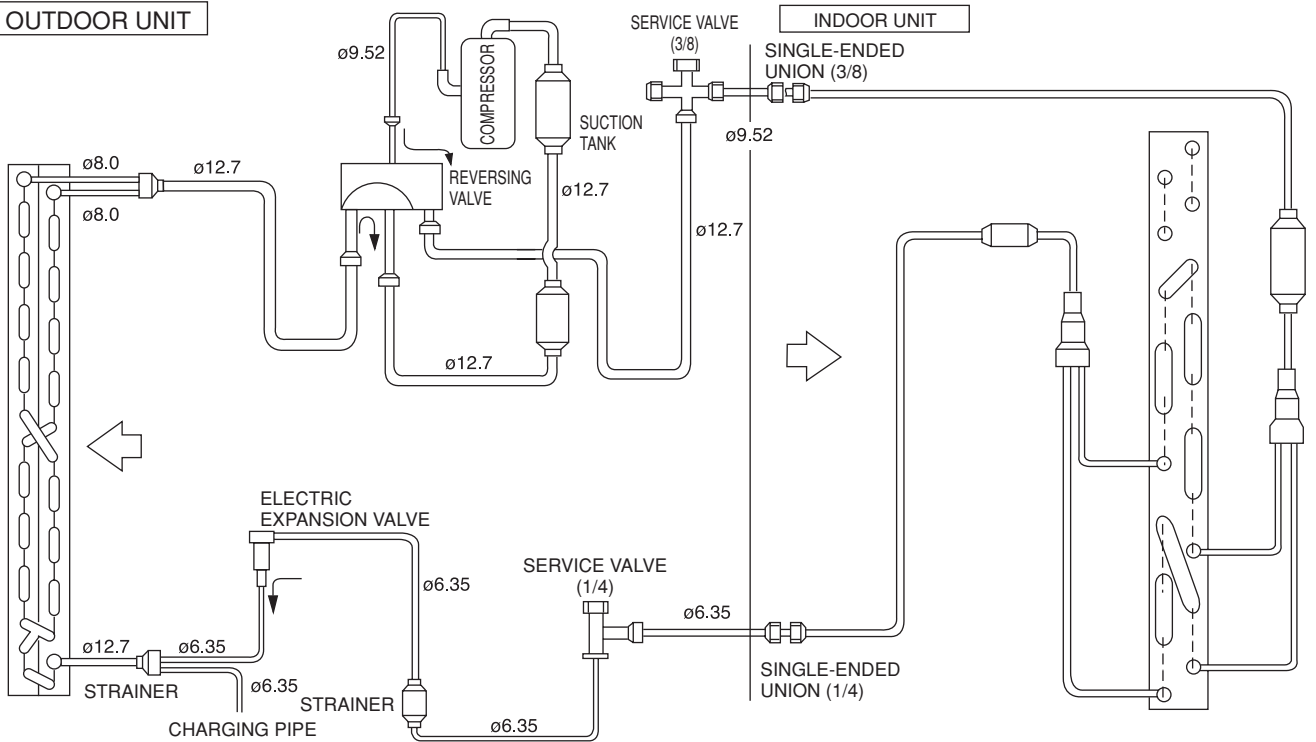

REFRIGERATING CYCLE DIAGRAM

MODEL RAI-40NH4
RAC-50NH4

COOLING, DEHUMIDIFYING, DEFROSTING

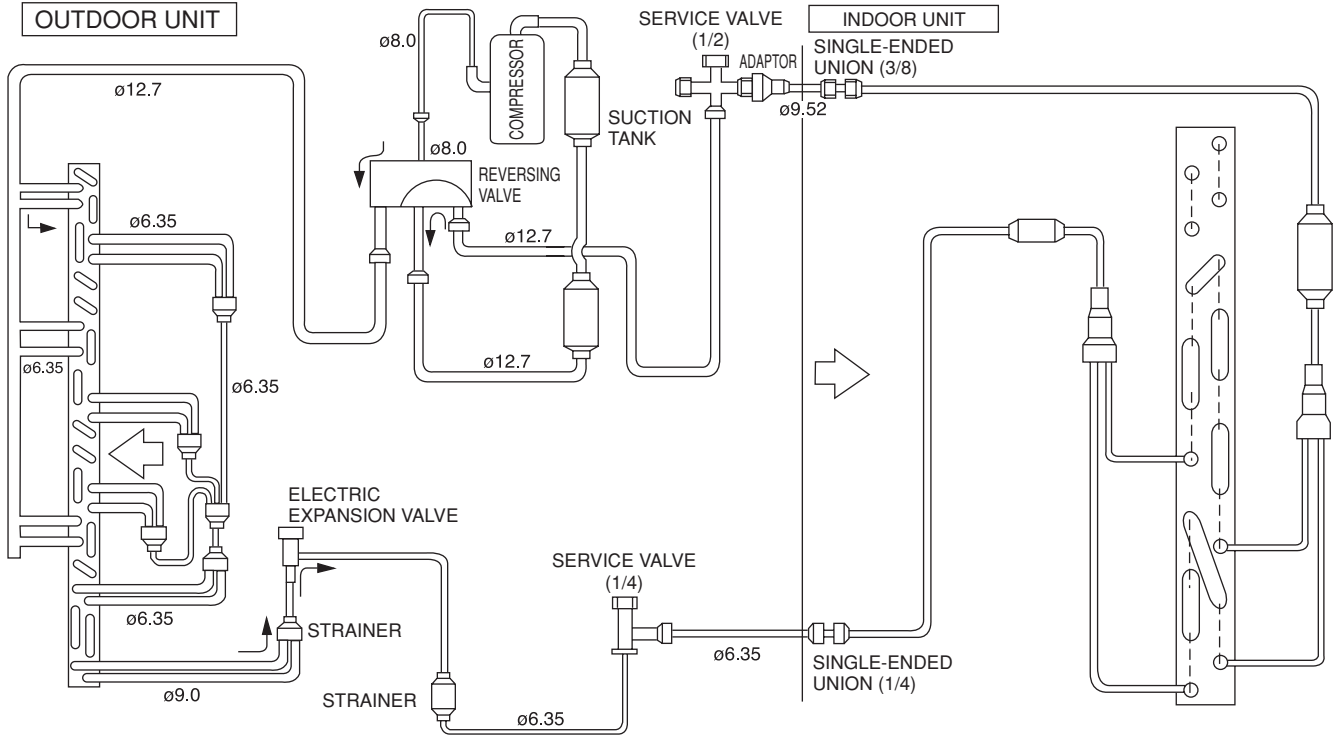

HEATING

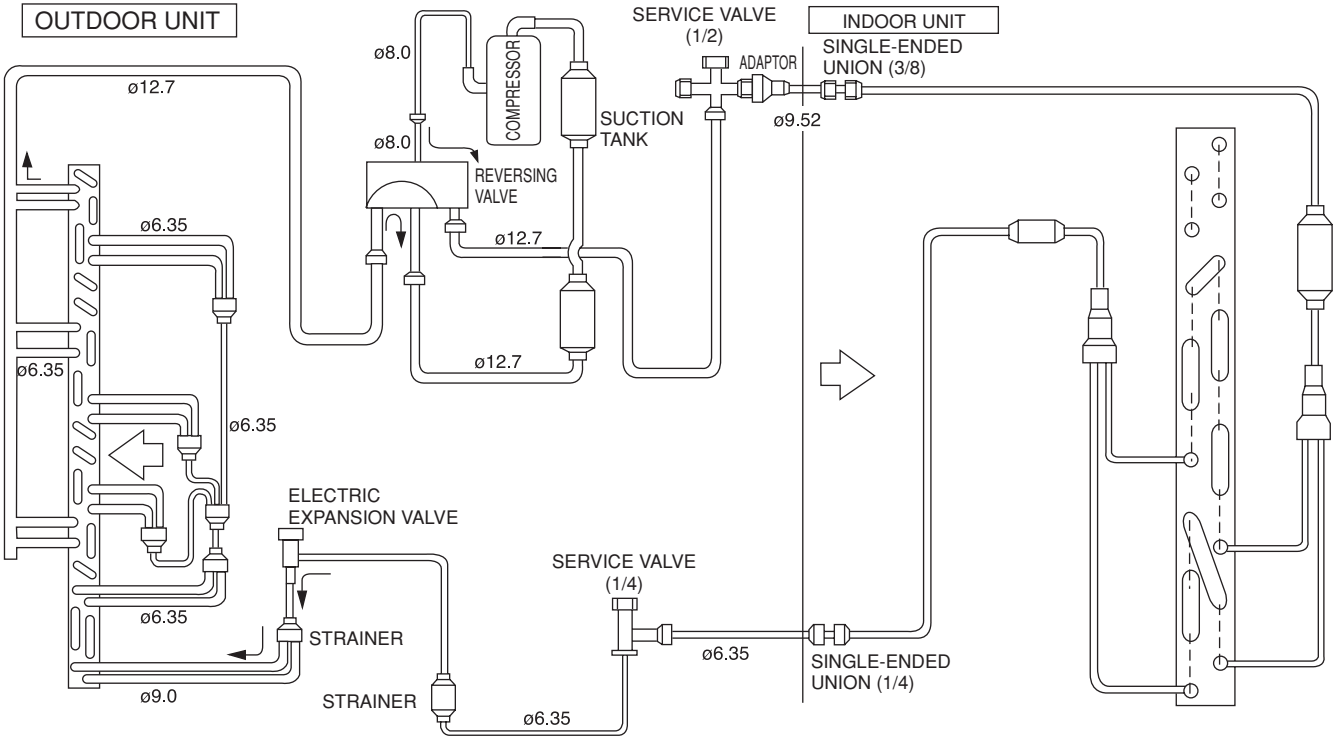

AUTO SWING FUNCTION

MODEL: RAI-25NH4, RAI-40NH4

INPUT SIGNAL	OPERATION	PRESENT CONDITION		OPERATING SPECIFICATION	REFERENCE
		OPERATION MODE	AIR DEFLECTOR		
KEY INPUT	STOP	EACH MODE	STOP	ONE SWING (CLOSING AIR DEFLECTOR) ① DOWNWARD ② UPWARD	INITIALIZE AT NEXT OPERATION.
	DURING OPERATION	AUTO COOL COOL FAN AUTO DRY DRY	DURING ONE SWING	STOP AT THE MOMENT.	
			STOP	START SWINGING ① DOWNWARD ② UPWARD ③ DOWNWARD	
THERMO. ON (INTERNAL FAN ON)	DURING OPERATION	AUTO HEAT HEAT CIRCULATOR	DURING SWINGING	STOP AT THE MOMENT.	
			STOP	START SWINGING ① DOWNWARD ② UPWARD ③ DOWNWARD	
			DURING SWINGING	STOP AT THE MOMENT.	
THERMO. ON (INTERNAL FAN OFF)	DURING OPERATION	AUTO DRY DRY AUTO HAET HEAT CIRCULATOR	TEMPORARY STOP	START SWING AGAIN.	
			DURING SWINGING	STOP SWINGING TEMPORARILY. (SWING MODE IS CLEARED IF SWING COMMAND IS TRANSMITTED DURING TEMPORARY STOP.)	
MAIN SWITCH ON	STOP	COOL FAN DRY HEAT CIRCULATOR	STOP DURING ONE SWING	INITIALIZE ① DOWNWARD ② UPWARD	
			STOP DURING ONE SWING	INITIALIZE ① DOWNWARD	
MAIN SWITCH OFF	DURING OPERATION	EACH MODE	STOP DURING SWINGING	ONE SWING (CLOSING AIR DEFLECTOR) ① DOWNWARD ② UPWARD	INITIALIZE AT NEXT OPERATION.
			DURING INITIALIZING	INITIALIZING CONDITION OF EACH MODE.	
CHANGE OF OPERATION	DURING OPERATION	EACH MODE	STOP	INITIALIZING CONDITION OF EACH MODE.	
			DURING SWINGING	STOP SWINGING AND MODE BECOMES INITIALIZING CONDITION.	

DESCRIPTION OF MAIN CIRCUIT OPERATION

MODEL RAI-25NH4, RAI-40NH4

1. Reset Circuit

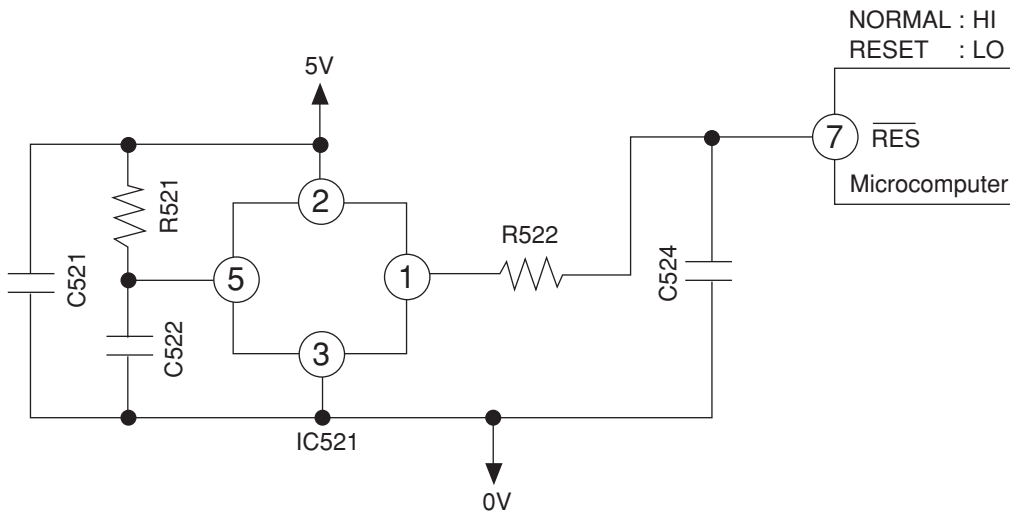

Fig. 1-1

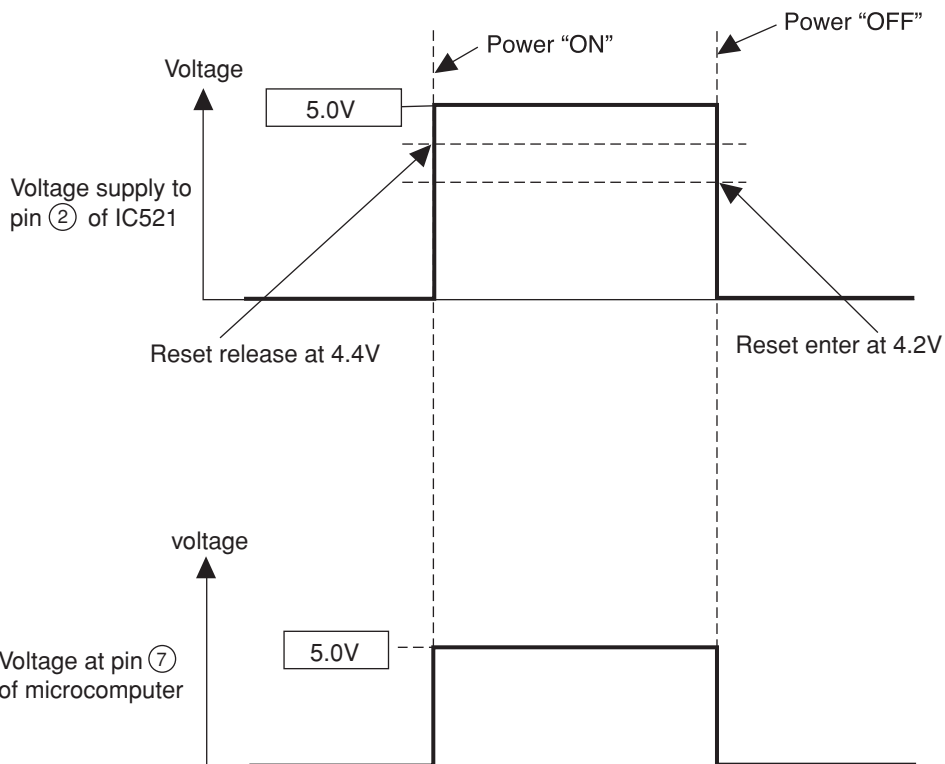

Fig. 1-2

- The reset circuit initializes the microcomputer program when power is ON or OFF.
- Low voltage at pin ⑦ resets the microcomputer and Hi activates the microcomputer.
- When power "ON" 5V voltage rises and reaches 4.4V, pin ① of IC521 is set to "Hi". At this time the microcomputer starts operation.
- When power "OFF" voltage drops and reaches 4.2V, pin ① of IC521 is set to "Low". This will RESET the microcomputer.

2. Receiver Circuit

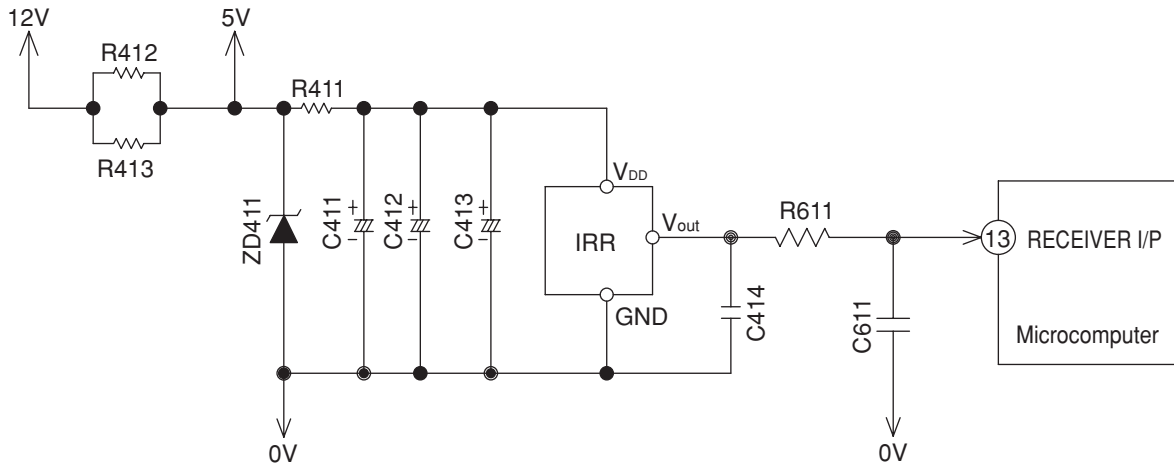

Fig. 2-1

- The light receiver unit receives the infrared signal from the wireless remote control. The receiver amplifies and shapes the signal and outputs it.

3. Buzzer Circuit

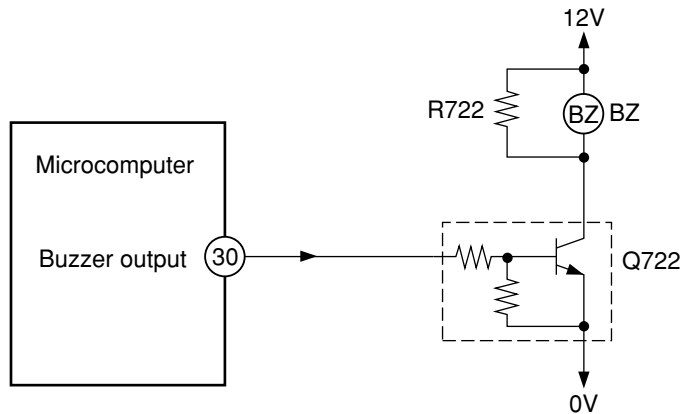

Fig. 3-1 Buzzer Circuit

- When the buzzer sounds, an approx. 3.9kHz square signal is output from buzzer output pin (30) of the microcomputer. After the amplitude of this signal has been set to 12Vp-p by a transistor, it is applied to the buzzer. The piezoelectric element in the buzzer oscillates to generate the buzzer's sound.

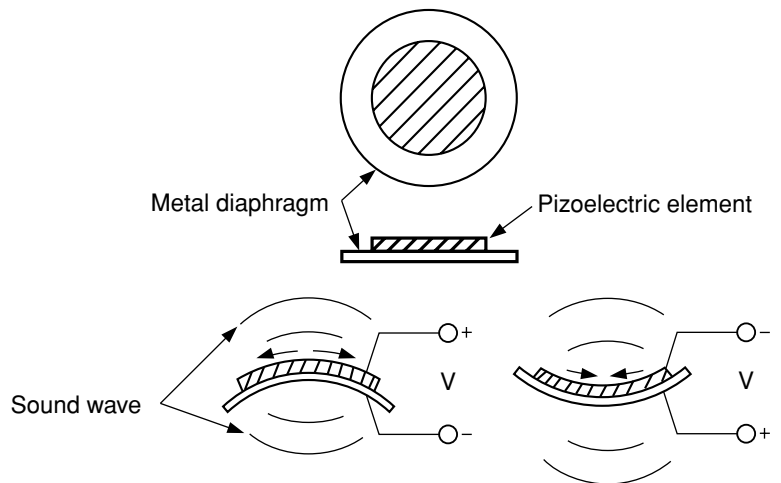

Fig. 3-2 Buzzer Operation

4. Auto Sweep Motor Circuit

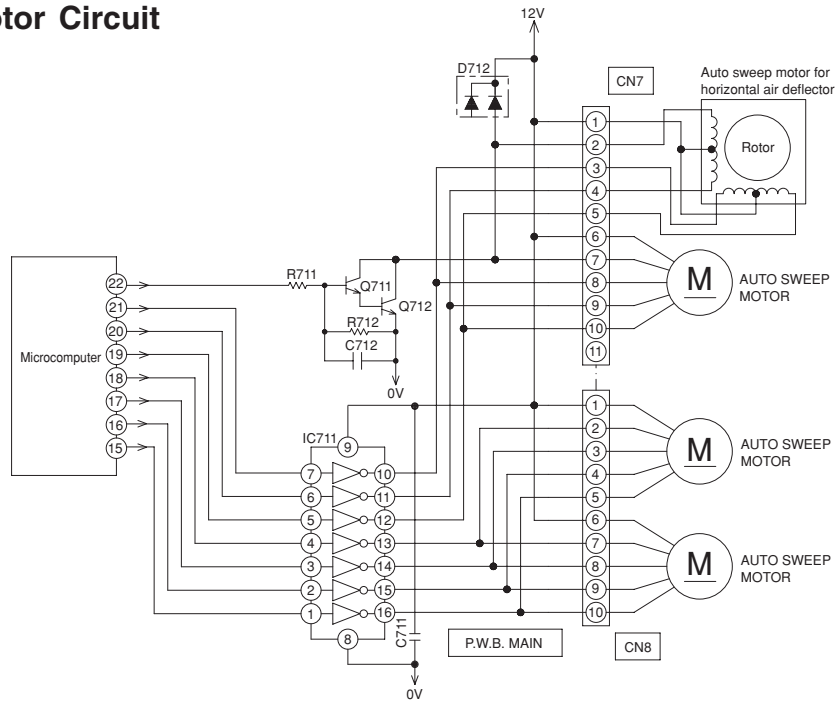

Fig.4-1

- Fig. 4-1 shows the Auto sweep motor drive circuit; the signals shown in Fig.4-2 are output from pins ⑮ – ㉒ of microcomputer.

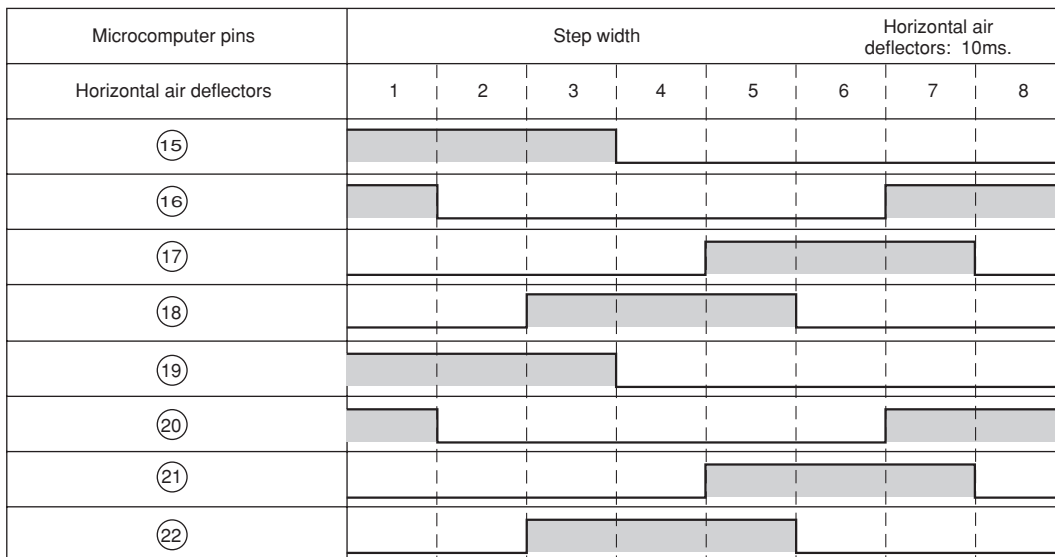

Fig.4-2 Microcomputer Output Signals

- As the microcomputer's outputs change as shown in Fig.4-2, the core of the auto sweep motor is excited to turn the rotor. Table 4-1 shows the rotation angle of horizontal air deflectors.

Table 4-1 Auto sweep Motor Rotation

	Rotation angle per step (°)	Time per step (ms.)
Horizontal air deflectors	0.0882	10

- The air deflectors are driven by the stepping motors, which are instructed by the microcomputer.
- The air deflectors on the left and right are each driven by two stepping motors.
- The stepping motors and main unit are connected via relay connectors. The air deflectors will not operate unless the relay connectors are connected: Securely connect the relay connectors identified by colors when attaching the panel.
- Before removing the panel for servicing, be sure to disconnect the relay connector to protect the lead wires.

5. Room Temperature Thermistor Circuit

- Fig. 5-1 shows the room temperature thermistor circuit.

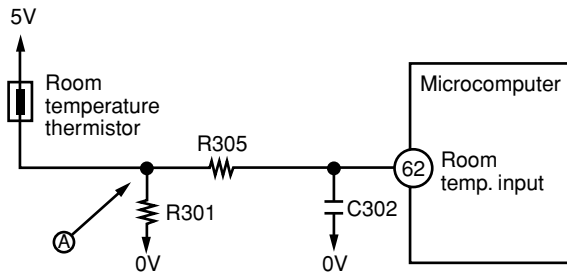

Fig. 5-1

- The voltage at (A) depends on the room temperature as shown in Fig. 5-2.

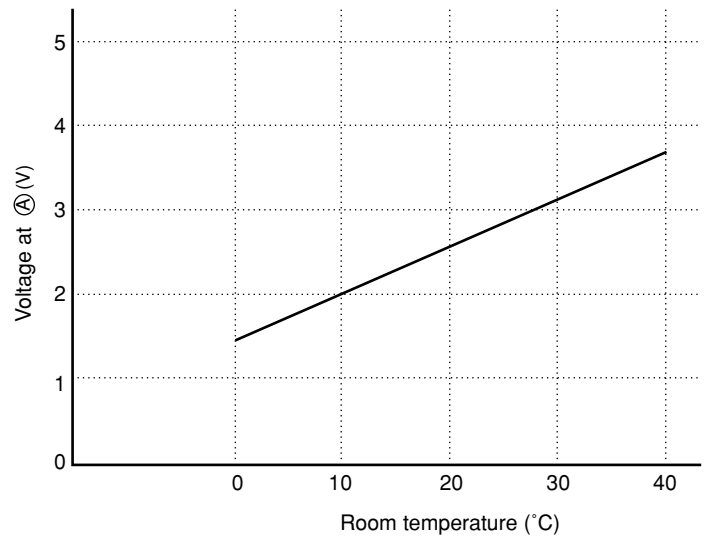

Fig. 5-2

6. Heat exchanger temperature thermistor circuit

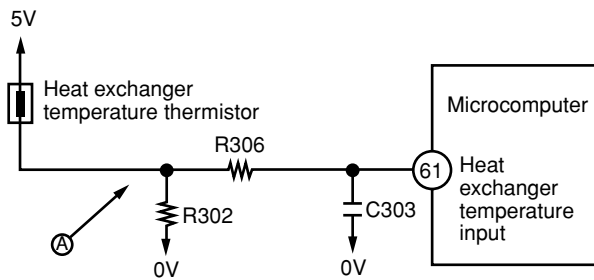

Fig. 6-1

- The circuit detects the indoor heat exchanger temperature and controls the following.

- (1) Preheating.
- (2) Low-temperature defrosting during cooling and dehumidifying operation.
- (3) Detection of the reversing valve non-operation or heat exchanger temperature thermistor open.

The voltage at (A) depends on the heat exchanger temperature as shown in Fig. 6-2.

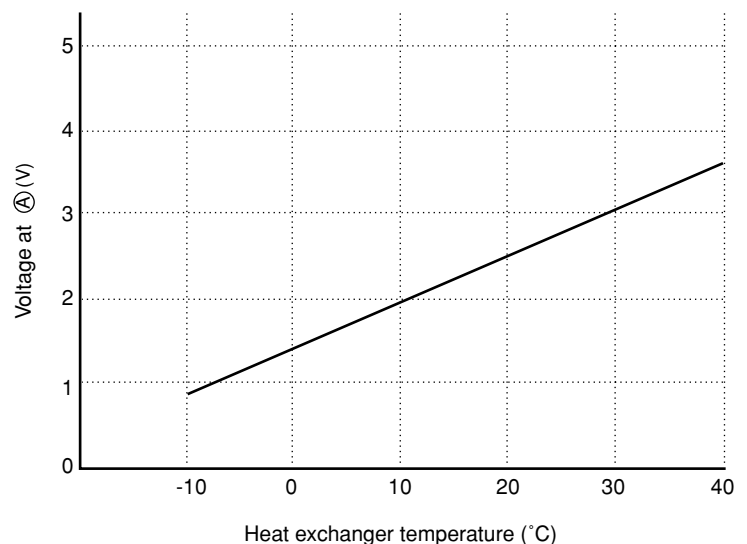

Fig. 6-2

7. Initial Setting Circuit (IC401)

- When power is supplied, the microcomputer reads the data in IC401 (E²PROM) and sets the preheating activation value and the rating and maximum speed of the compressor, etc. to their initial values.
- Data of self-diagnosis mode is stored in IC401; data will not be erased even when power is turned off.

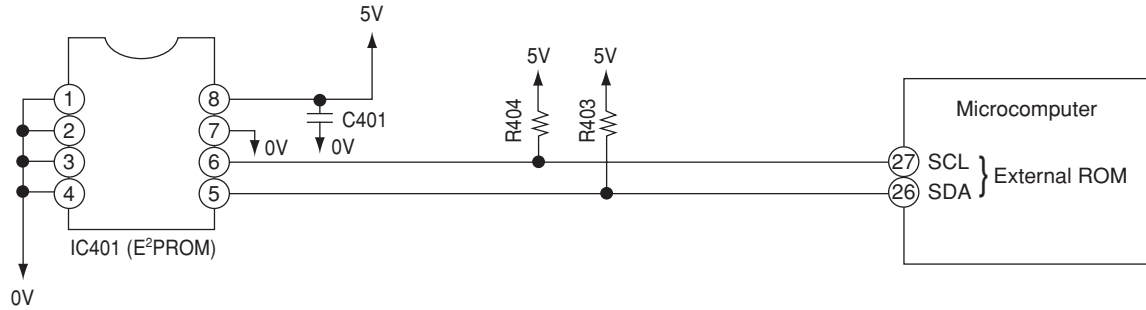

Fig. 7-1

Model RAI-25NH4, RAI-40NH4

1. Power Circuit

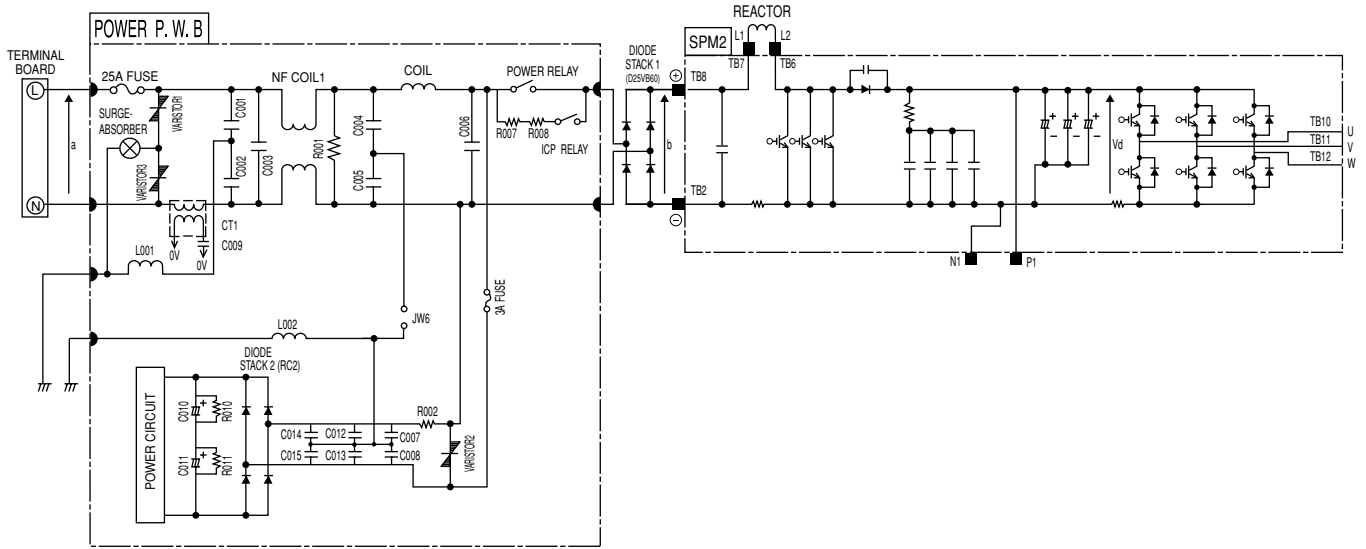

Fig. 1-1

- This circuit full-wave rectifies 220-230V AC applied between terminals L and N, and boosts it to a required voltage with the active module, to create a DC voltage.

The voltage becomes 260-360V when the compressor is operated

(1) Active module

The active filter, consisting of a reactor and switching element, eliminates higher harmonic components contained in the current generated when the compressor is operated, and improves the power-factor.

(2) Diode stacks

These rectify the 220-230V AC from terminals L and N to a DC power supply.

< Reference >

- In case of malfunction or defective connection: Immediately after the compressor starts, it may stop due to “abnormally low speed” active error, etc.

The compressor may continue to operate normally, but the power-factor will decrease, the operation current will increase, and the overcurrent breaker of the household power board will probably activate.

- In case of active module faulty or defective connection:

Although the compressor continues to operate normally, the power-factor will decrease, the operation current will increase, and the overcurrent breaker of the household power board will probably activate.

< Reference >

- If diode stack 1 is faulty, the compressor may stop due to “Ip”, “abnormally low speed”, etc. immediately after it starts, or it may not operate at all because no DC voltage is generated between the positive ⊕ and negative ⊖ terminals.

If diode stack 1 is faulty, be aware that the 25A fuse might also have blown.

- If diode stack 2 is faulty, DC voltage may not be generated and the compressor may not operate at all. Also, be aware that the 3A fuse might have blown.

(3) Smoothing capacitor (C501, C502, C503)

This smoothes (averages) the voltage rectified by the diode stacks.

<Notes> Smoothing capacitor C501 is not available for model RAC-25NH4 and RAC-35NH4.

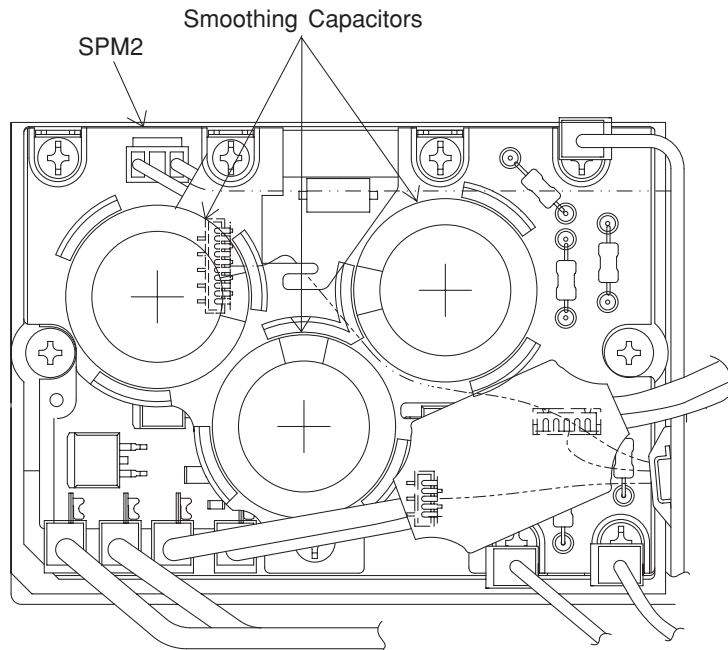

Fig. 1-2

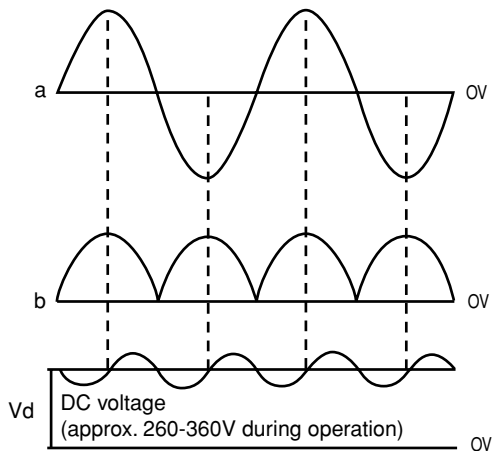

Fig. 1-3

- Be careful to avoid an electric shock as a high voltage is generated. Also take care not to cause a short-circuit through incorrect connection of test equipment terminals. The circuit board could be damaged.

(4) Smoothing capacitor (C010, C011)

This smoothes (averages) the voltage rectified by the diode stack2. A DC voltage is generated in the same way as in Fig. 1-3.

Voltage between + side of C010 and – side of C011 is about 330V.

(5) C001 to C003, C012 to C015, C007, C008, NF COIL1, COIL, absorb electrical noise generated during operation of compressor, and also absorb external noise entering from power line to protect electronic parts.

(6) Surge absorber, Varistor 1, 2, 3, absorbs external power surge.

(7) Inrush protective resistor (R007, R008)

This works to protect from overcurrent when power is turned on.

< Reference >

- When inrush protective resistor is defective, diode stack may malfunction. As a result, DC voltage is not generated and no operation can be done.

2. Indoor/Outdoor Interface Circuit

- The interface circuit superimposes an interface signal on the DC 35V line supplied from the outdoor unit to perform communications between indoor and outdoor units. This circuit consists of a transmitting circuit which superimposes an interface signal transmit from the microcomputer on the DC 35V line and a transmitting circuit which detects the interface signal on the DC 35V line and outputs it to the microcomputer.
- Communications are performed by mutually transmitting and receiving the 4-frame outdoor request signal one frame of which consists of a leader of approx. 100 ms., start bit, 8-bit data and stop bit and the command signal with the same format transmit from the indoor unit.
- Communication signal from outdoor microcomputer to indoor microcomputer. At first outdoor microcomputer will send a request signal (SDO) to indoor microcomputer. A high-frequency IF signal approx. 38 KHz is generated and modulated by the request signal (SDO) inside the outdoor microcomputer then output to pin (11) of microcomputer. This modulated IF signal is output to pin (30) of HIC and amplified by amp. This signal is superimposed to DC 35V line via C801 and L801.
To prevent erroneous reception, the outdoor microcomputer is designed so that it cannot receive a signal while it is outputting a request signal.
The receiving circuit in the indoor unit consists of a comparator and transistor. The interface signal from the outdoor unit on the DC 35V line is supplied to C821, where DC components are eliminated, and is then shaped by the comparator. The shaped signal is detected by diode, amplified by amp, and output to pin (49) of the indoor microcomputer.
Fig. 2-2 shows the voltages at each component when data is transferred from the outdoor microcomputer to the indoor microcomputer.
- Communication signal from indoor microcomputer to outdoor microcomputer. The request signal (SDO) generates by indoor microcomputer is output to pin (50), and amplifies by C801. IF signal approx. 38 kHz is generated by comparator, then modulate by the request signal from pin (50) of indoor microprocessor. This modulated IF signal is then amplified and superimposed to DC 35V line via L801 and C802 of indoor interface circuit.
Fig. 2-3 shows the voltages at each component when data is transferred from outdoor microcomputer to indoor microcomputer.
The circuit operation of the outdoor receiving circuit is same as indoor receiving circuit.

- Fig. 2-1 shows the interface circuit used for the indoor and outdoor microcomputers to communicate with each other.

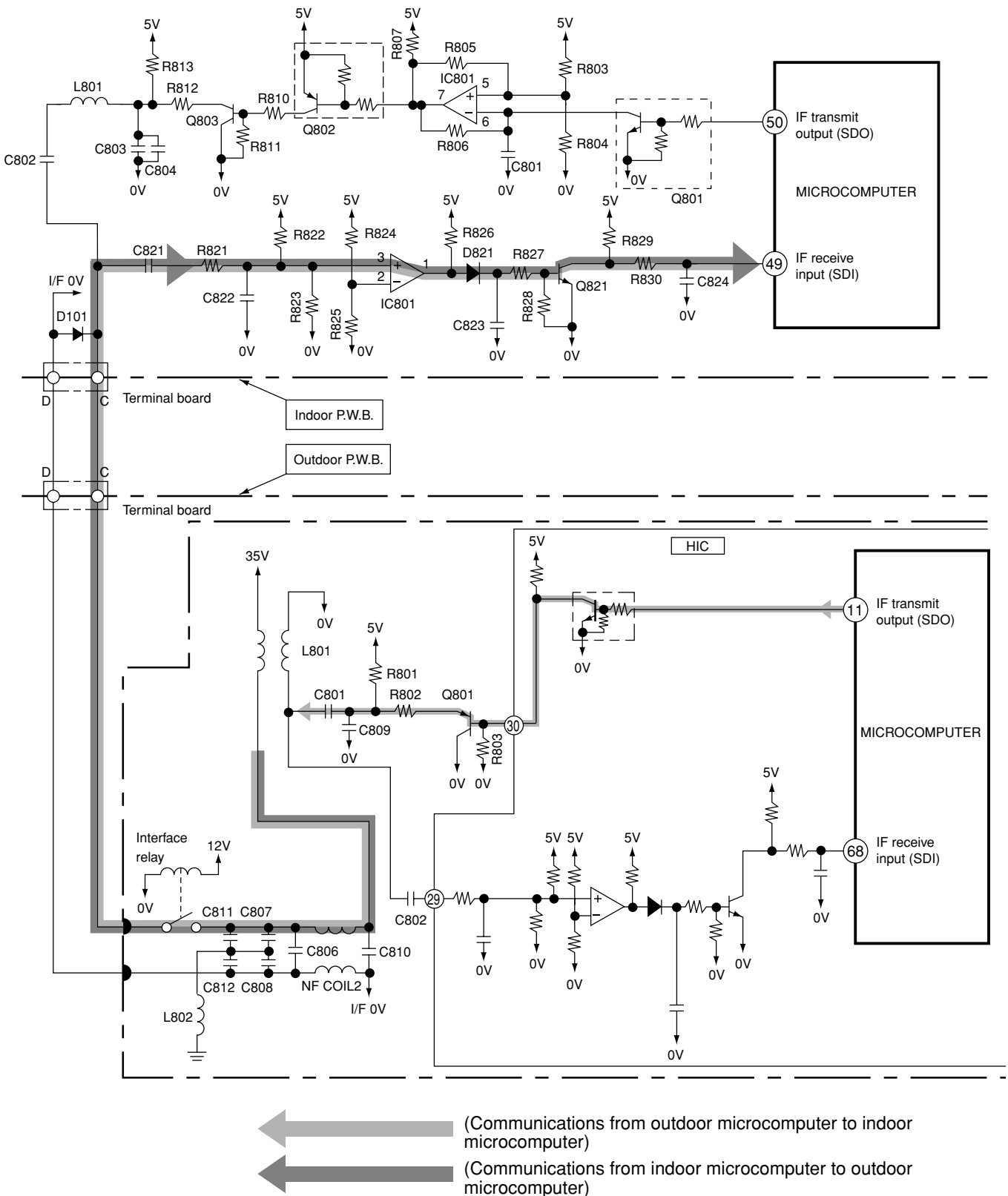

Fig. 2-1 Indoor/outdoor interface Circuit

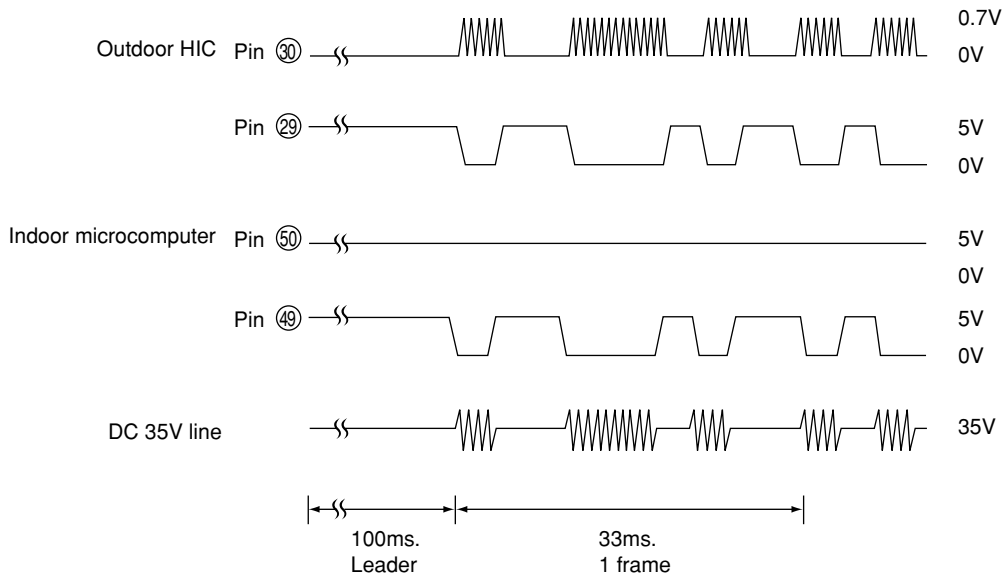

Fig. 2-2 Voltages Waveforms of indoor / Outdoor Microcomputers (Outdoor to Indoor Communications)

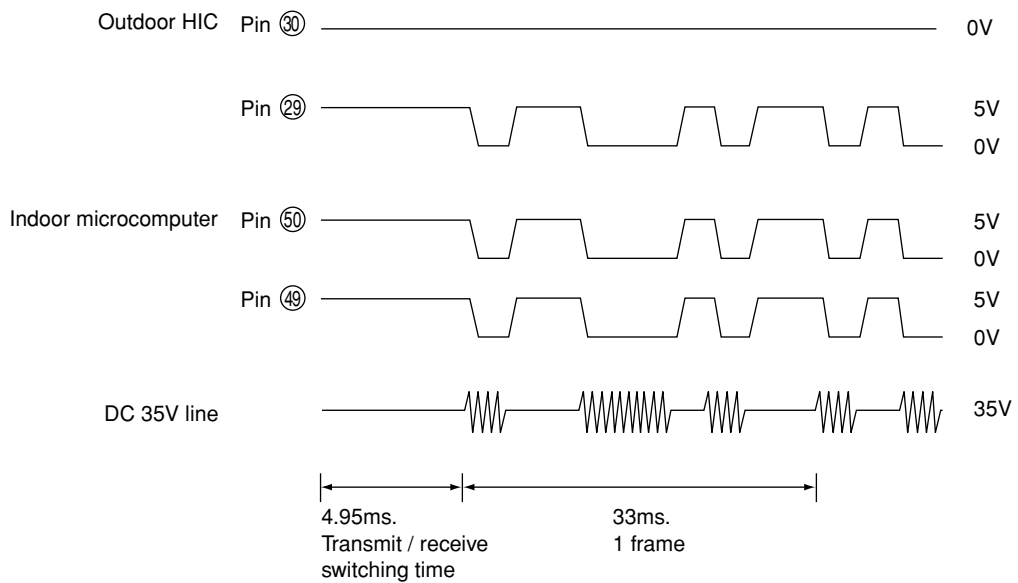
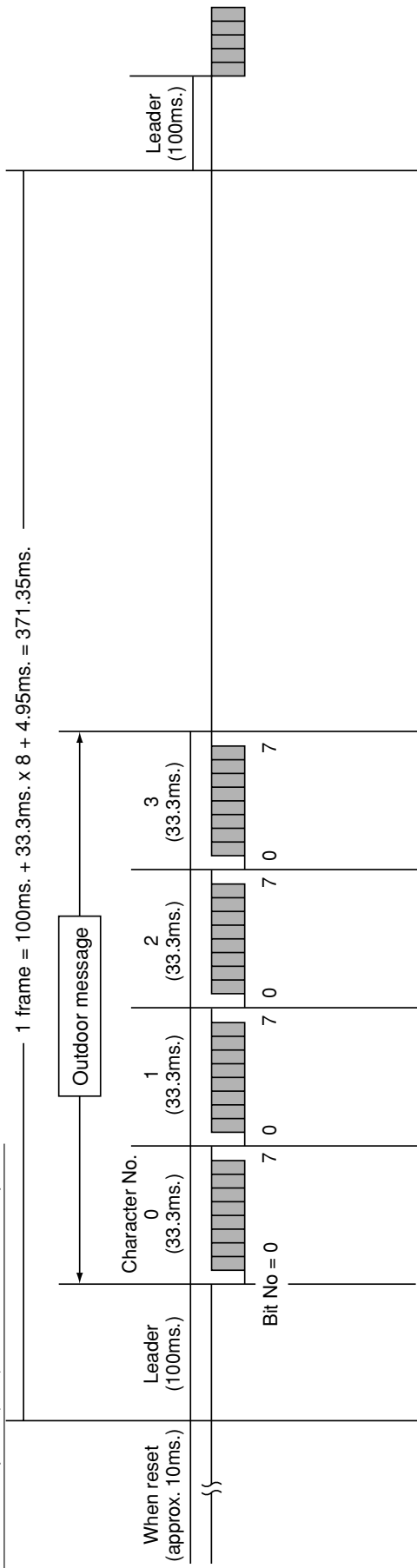

Fig. 2-3 Voltages Waveforms of indoor / Outdoor Microcomputers (Indoor to Outdoor Communications)

[Serial Communications Format during Normal Communications]

(1) Outdoor microcomputer (HIC) to indoor microcomputer



(2) Indoor microcomputer to outdoor microcomputer (HIC)

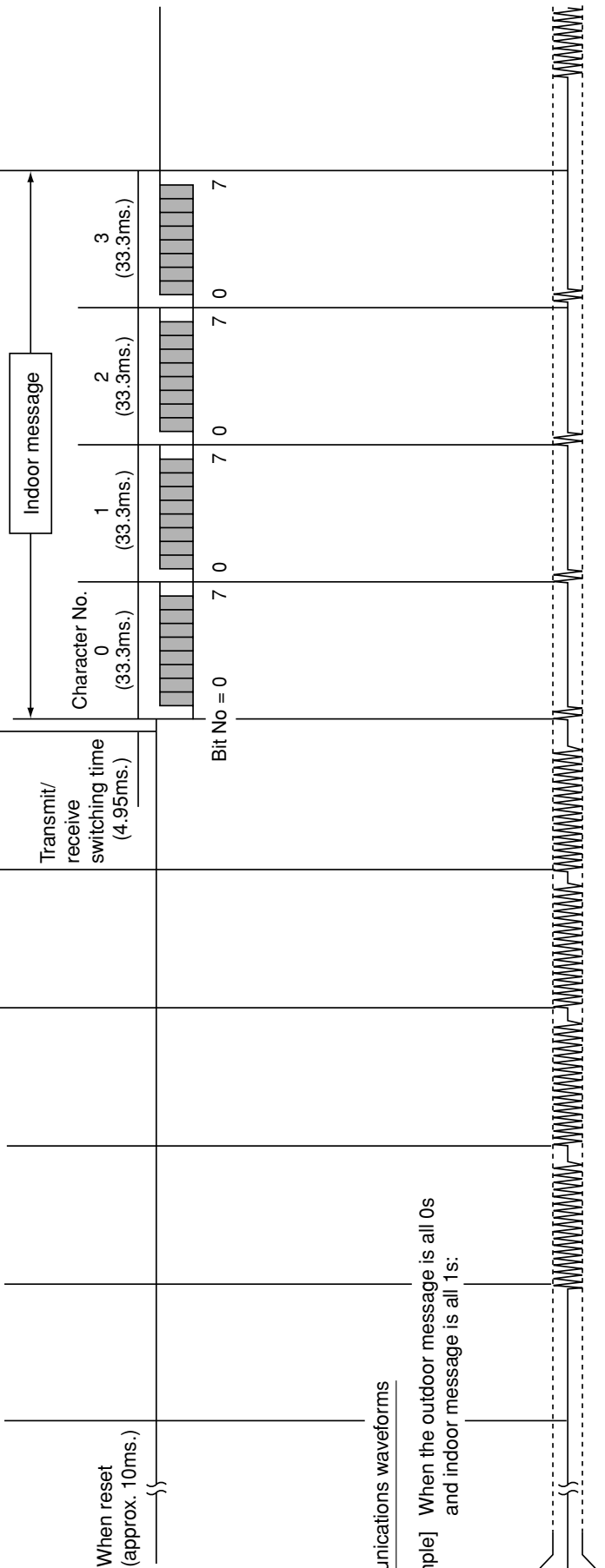

(3) Communications waveforms

[Example] When the outdoor message is all 0s and indoor message is all 1s:

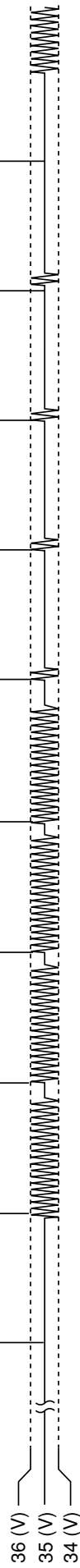

Fig. 2-4

[Serial Communications Data]

(1) Outdoor message

Character No.	0								1								2								3													
Bit No.	7	6	5	4	3	2	1	0	7	6	5	4	3	2	1	0	7	6	5	4	3	2	1	0	7	6	5	4	3	2	1	0						
Contents	Multi-bit								During forced operation	Defrost request signal	Self-diagnosis (0 LSB)	Self-diagnosis (1)	Self-diagnosis (2)	Self-diagnosis (3 MSB)	Outside temperature (0 LSB)	Outside temperature (1)	Outside temperature (2)	Outside temperature (3)	Outside temperature (4)	Outside temperature (5)	Outside temperature (6)	Outside temperature (7 MSB)	Compressor during operation	Compressor during operation	Actual compressor rotation speed (0 LSB)	Actual compressor rotation speed (1)	Actual compressor rotation speed (2)	Actual compressor rotation speed (3)	Actual compressor rotation speed (4)	Actual compressor rotation speed (5 MSB)	Fan-7-step request							
Data	1/0	0	1/0	1/0	1/0	1/0	1/0	1/0	1/0	1/0	1/0	1/0	1/0	1/0	1/0	1/0	1/0	1/0	1/0	1/0	1/0	1/0	1/0	1/0	1/0	1/0	1/0	1/0	1/0	1/0	1	0	0	0	0	0	0	0

(2) Indoor message

Character No.	0								1								2								3															
Bit No.	7	6	5	4	3	2	1	0	7	6	5	4	3	2	1	0	7	6	5	4	3	2	1	0	7	6	5	4	3	2	1	0								
Contents	Operation mode (0 LSB)	Operation mode (1)	Operation mode (2 MSB)	Indoor in-operation bit	Capacity code (0 LSB)	Capacity code (1)	Capacity code (2)	Capacity code (3 MSB)	Fan (0 LSB)	Fan (1)	Fan (2 MSB)	2-way valve	Reversing valve			Compressor ON	Compressor command speed (0 LSB)	Compressor command speed (1)	Compressor command speed (2)	Compressor command speed (3)	Compressor command speed (4)	Compressor command speed (5)	Compressor command speed (6)	Compressor command speed (7 MSB)	15/20(A)	OVL up							Compressor minimum rotation speed (0 LSB)	Compressor minimum rotation speed (1)	Compressor minimum rotation speed (2)	Compressor minimum rotation speed (3)	Compressor minimum rotation speed (4 MSB)			
Data	1/0	1/0	1/0	1/0	0	0	0	0	1/0	1/0	1/0	0	1/0	0	0	1/0	1/0	1/0	1/0	1/0	1/0	1/0	1/0	1/0	1/0	1/0	1/0	1/0	1/0	1/0	1/0	1/0	1/0	1/0	1/0	1/0	1/0	1/0	1/0	1/0

3. Power Module Circuit

- Fig. 3-1 shows the system power module and its peripheral circuit. The three transistors on the positive ⊕ side are called the upper arm, and the three transistors on the negative ⊖ side, the lower arm.

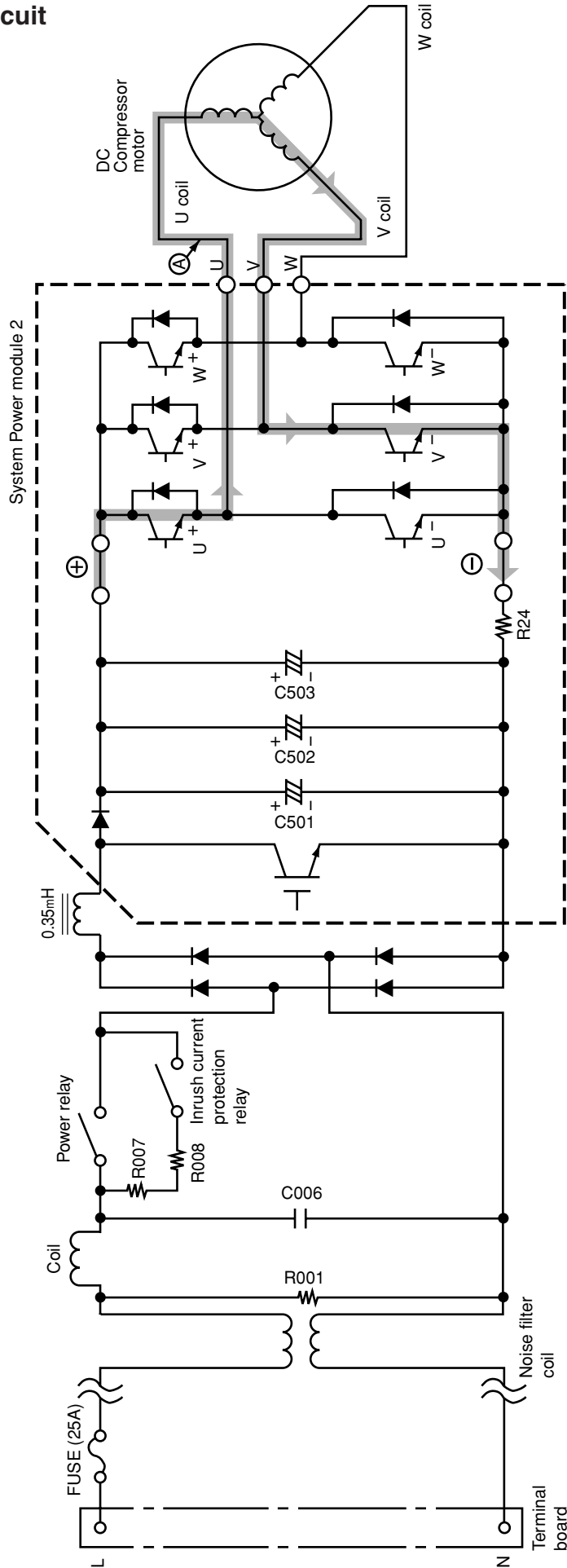

Fig. 3-1 Power module circuit (U⁺ is ON, V⁻ is ON)

- DC 260-360V is input to system power module and system power module switches power supply current according to rotation position of magnet rotor. The switching order is as shown in Fig. 3-2.

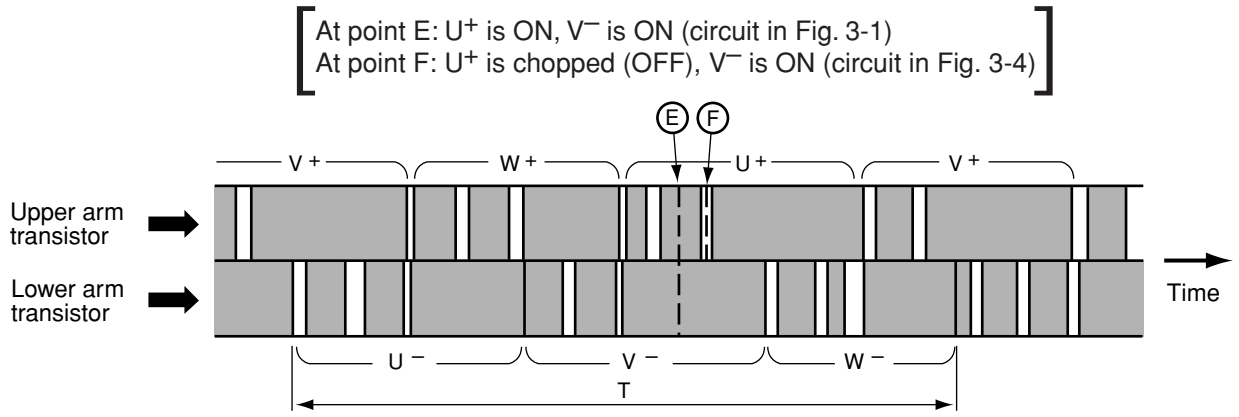

Fig. 3-2 Switching order of power module

- Upper arm transistor is controlled to ON/OFF by 3.3kHz chopper signal. Rotation speed of the compress is proportional to duty ratio (ON time/ ON time + OFF time) of this chopper signal.
- Time T in Fig. 3-2 shows the switching period, and relation with rotation speed (N) of the compressor is shown by formula below;

$$N = 60/2 \times 1/T$$

- Fig. 3-3 shows voltage waveform at each point shown in Figs. 3-1 and 3-4. First half of upper arm is chopper, second half is ON, and first half of lower arm is chopper, second half is ON.

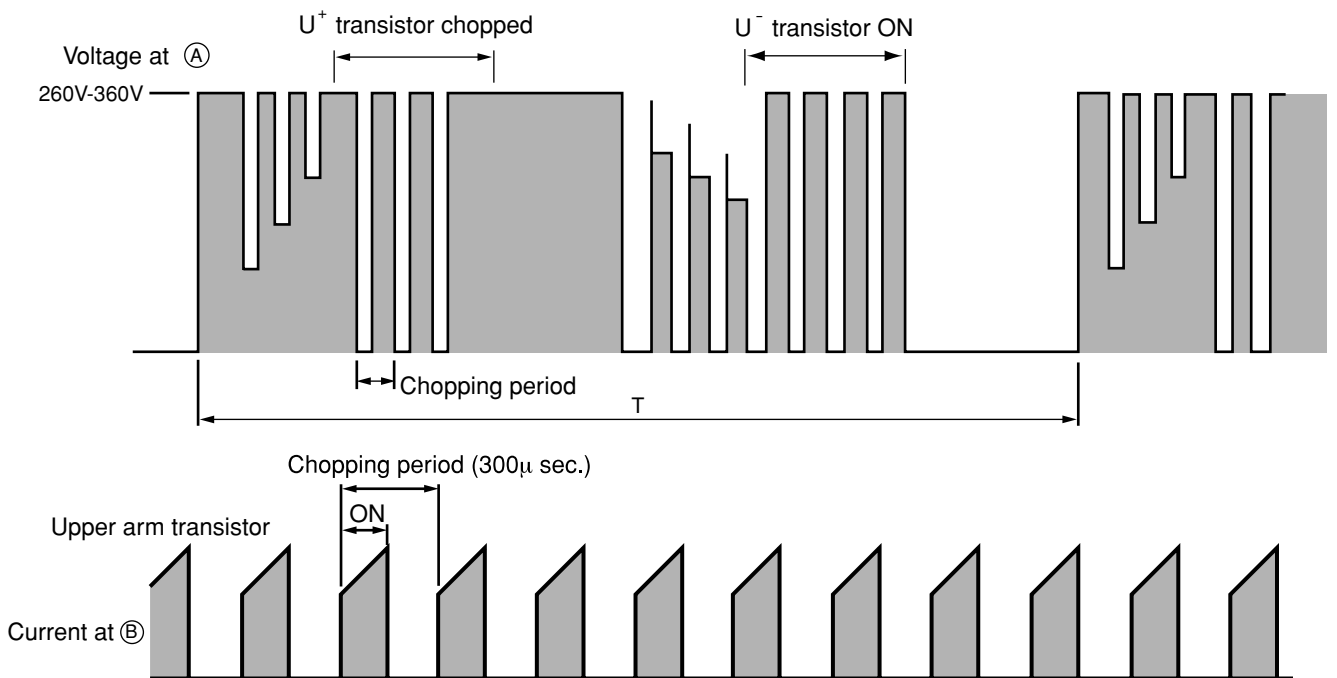

Fig. 3-3 Voltage waveform at each point

- When power is supplied U⁺ → U⁻, because of that U⁺ is chopped, current flows as shown below; (B)
 - (1) When U⁺ transistor is ON: U⁺ transistor → U coil → V coil → V⁻ transistor → DC current detection resistor → Point (B) (Fig. 3-1)
 - (2) When U⁺ transistor is OFF: (by inductance of motor coil) U coil → V coil → V⁻ transistor → Return diode → Point (A) (Fig. 3-4)

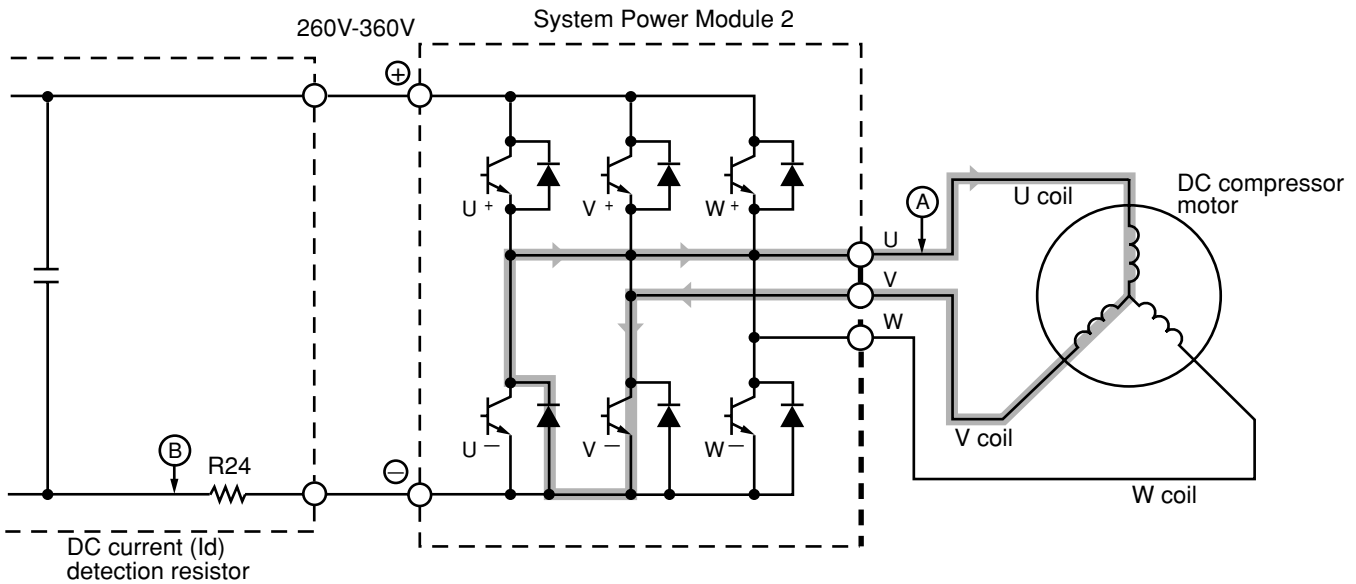

Fig. 3-4 Power module circuit (U⁺ is ON, V⁻ is ON)

- Since current flows at point B only when U⁺ transistor is ON, the current waveform at point B becomes intermittent waveform as shown in Fig. 3-3. Since current at point B is approximately proportional to the input current of the air conditioner, input current is controlled by using DC current (I_d) detection resistor.

<Reference>

If power module is defective, self diagnosis lamps on the control P.W.B. may indicate as shown below:

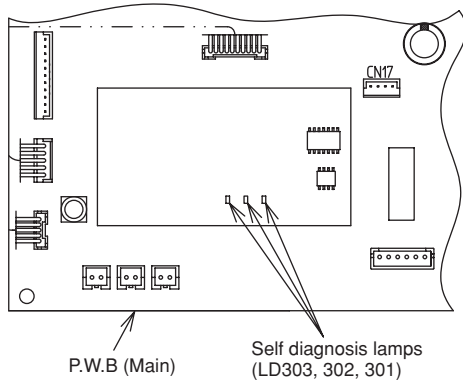

Fig. 3-5

Table 3-1

Self-diagnosis	Self-diagnosis lamp and mode	
I _p (peak current cut)	LD301	Blinks 2 times
Abnormal low speed rotation	LD301	Blinks 3 times
Switching incomplete	LD301	Blinks 4 times

- Simplified check of power module (Lighting mode when operated with compressor leads disconnected)
 - (1) Disconnect connector of 3-pole (WHT, YEL, RED) lead wire connecting to compressor located at the lower part of electric parts box.
 - (2) Set to compressor operation state (other than FAN mode) and press Start/stop switch of remote control.
 - (3) If normal operation continues for more than 1 minute (LD303 lights), power module is considered normal.

* Refer to other item (troubleshooting on page 94) for independent checking of power module.

4. Power Circuit for P.W.B.

- Fig. 4-1 shows the power circuit for P.W.B. and waveform at each point.

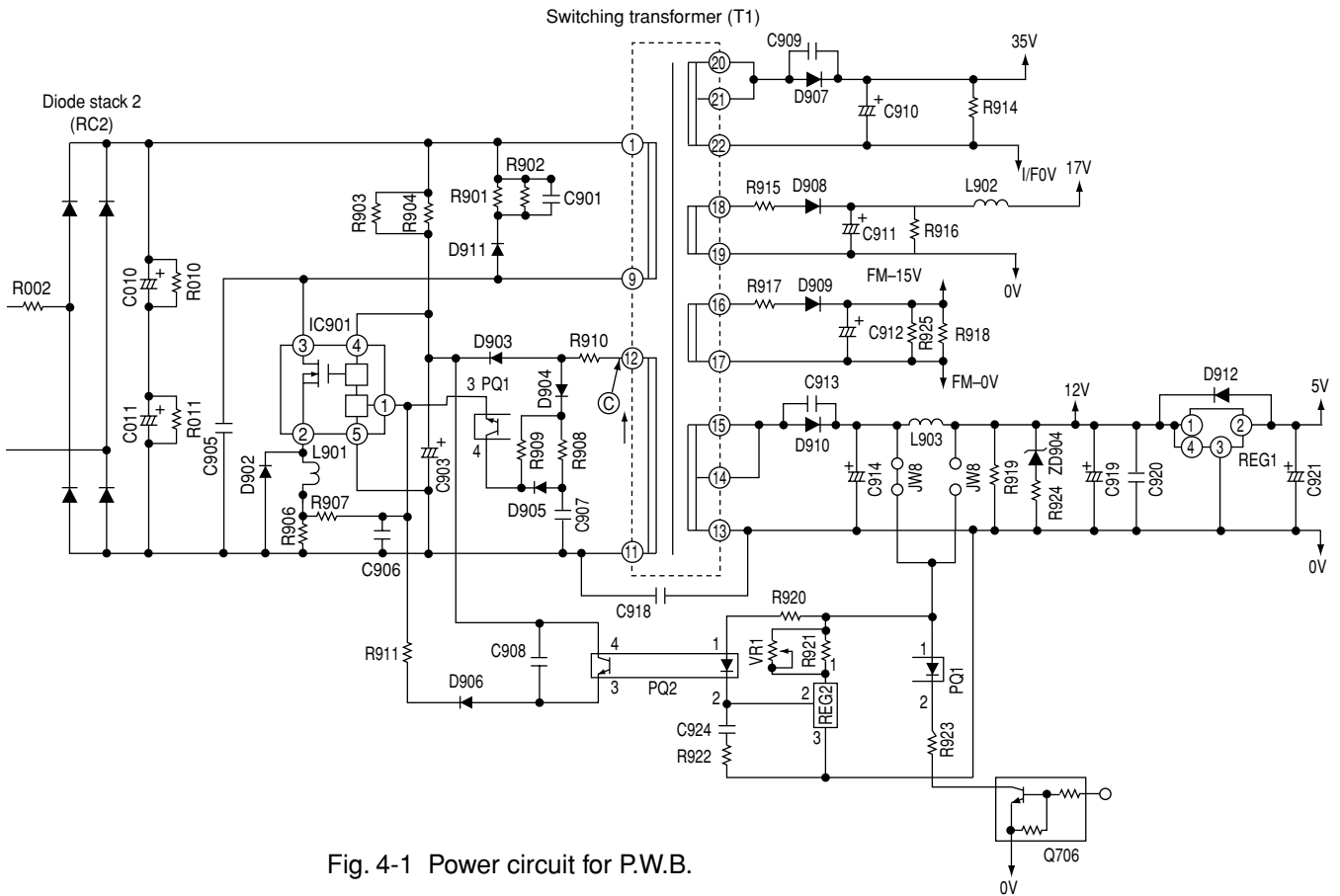

Fig. 4-1 Power circuit for P.W.B.

- In the power circuit for P.W.B., power supply for microcomputer, peripheral circuits, and system power module driver circuit and, as well as DC 35V, are produced by switching power circuit.
- Switching power circuit performs voltage conversion effectively by switching transistor IC901 to convert DC 330V voltage to high frequency of about 20kHz to 200kHz.
- Transistor IC901 operates as follows:

(1) Shifting from OFF to ON

- DC about 330V is applied from smoothing capacitors C010 ⊕ and C011 ⊖ in the control power circuit. With this power, current flows to pin ④ of IC901 via R903 and R904 and IC901 starts to turn ON. Since voltage in the direction of arrow generates at point ③ at the same time, current passing through R910 and D903 is positive-fed back to IC901.

(2) During ON

- The drain current at IC901 increases linearly. During this period, the gate voltage and current become constant because of the saturation characteristics of the transformer.

(3) Shifting from ON to OFF

- This circuit applies a negative feedback signal from the 12V output. When the voltage across C919 reaches the specified value, REG2 turns on and current flows to PQ2 ①-②. This turns the secondary circuits on, sets IC901 pin ① to "Hi", and turns IC901 off.

(4) During OFF

- While IC901 is on, the following energy charges the primary windings of the transformer:

Energy= $LI^2/2$. Here, L : Primary inductance

I : Current when IC1 is off

This energy discharges to the secondary windings during power off. That is, C910, C911, C912, C914 is charged according to the turn ratio of each winding.

- At the start, an overcurrent flows to IC901 because of the charged current at C910, C911, C912, C914.
- The drain current at IC901 generates a voltage across R906. If it exceeds the IC901 base voltage, it sets the IC901 gate voltage to "Hi".
- R906 limits the gate voltage to prevent excessive collector current from flowing to IC901.

<Reference>

If the power circuit for P.W.B. seems to be faulty:

- (1) Make sure that 5V and 12V on the control P.W.B., upper arm U, V and W, and the lower arm power voltage are the specified values.

- (2) When only the 5V output is low:

REG 1 (regulator) faulty, 5V-0V shorted, output is too high, or REG 1 is abnormal.

- (3) When 12V and 5V are abnormal:

The following defects can be considered:

① Fan, operation, power, rush prevention relay (shorting in relay, etc.)

② Microcomputer is abnormal.

③ REG 1 (regulator is abnormal), etc.

Shorting on primary circuits.

When shorting occurs in the secondary circuits, there is no abnormality in the primary circuits because of overcurrent protection.

The voltage rises when an opening occurs in the primary circuits, or the feedback system is abnormal.

- (4) When 15V and 17V are abnormal:

D908, D909 or drive circuit is abnormal.

- (5) When all voltage are abnormal:

IC901, R906, etc. are possibly abnormal.

* If IC901 is abnormal, be aware that other components, such as the power module, REG (regulator), etc. are possibly defective.

[When the switching power supply seems to be abnormal, the voltage between IC901 pin ④ (to be measured at the leads of R904 and R903) and IC901 pin ⑤ (to be measured at R906 lead) may be between 11 and 16V. This is because the protection circuit of IC901 is operating.]

5. Reversing valve control circuit

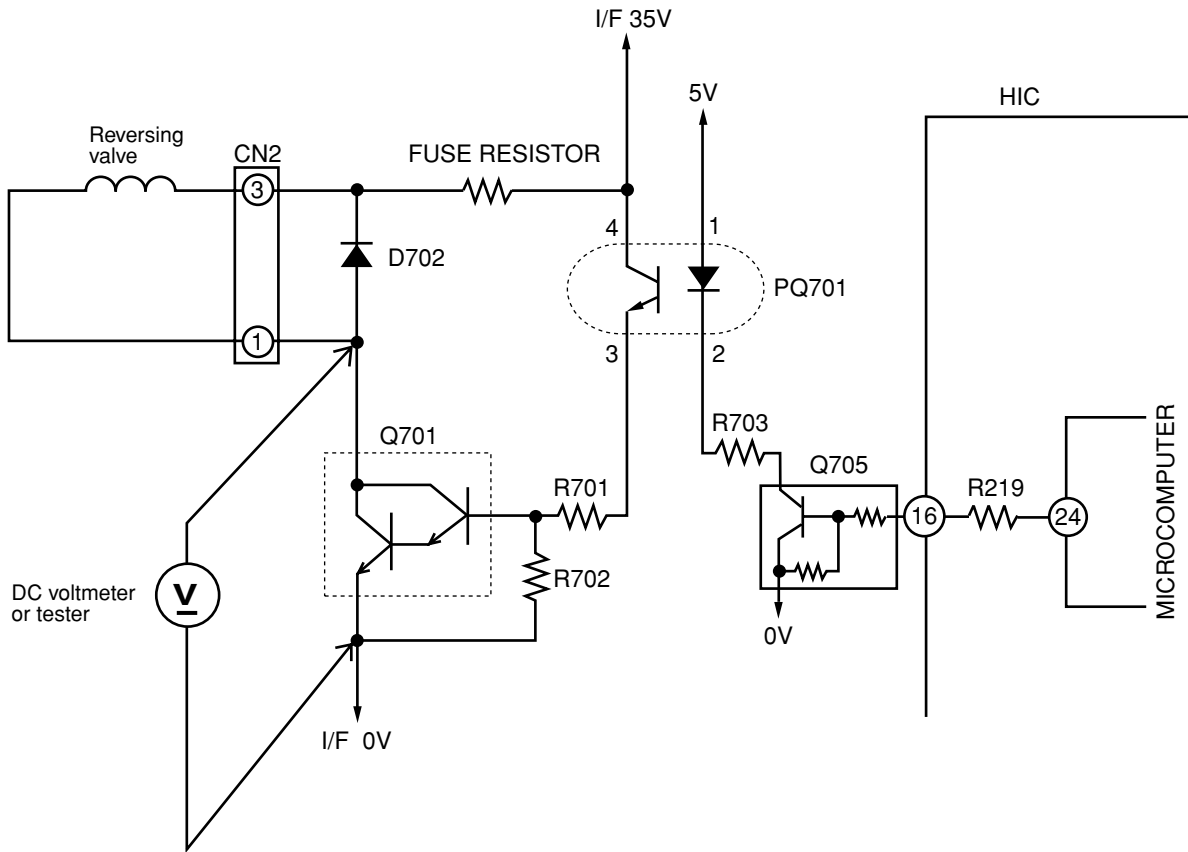

Fig. 5 - 1

- Reversing valve control circuit can switch reversing valve ON/OFF according to instruction from indoor microcomputer depending on the operation condition shows in Table 5-1. Voltage at each point in each operation condition is approximately as shown below when measured by tester. (When collector voltage of Q701 is measured)

Table 5-1

Operation condition		Collector voltage of Q701
Cooling	General operation of Cooling	About 35V
Heating	In normal heating operation	About 0.8V
	MAX. rotation speed instructed by indoor microcomputer after defrost is completed	About 0.8V
	Defrosting	About 35V
Dehumidifying	Sensor dry	About 35V

6. Rotor magnetic pole position detection circuit

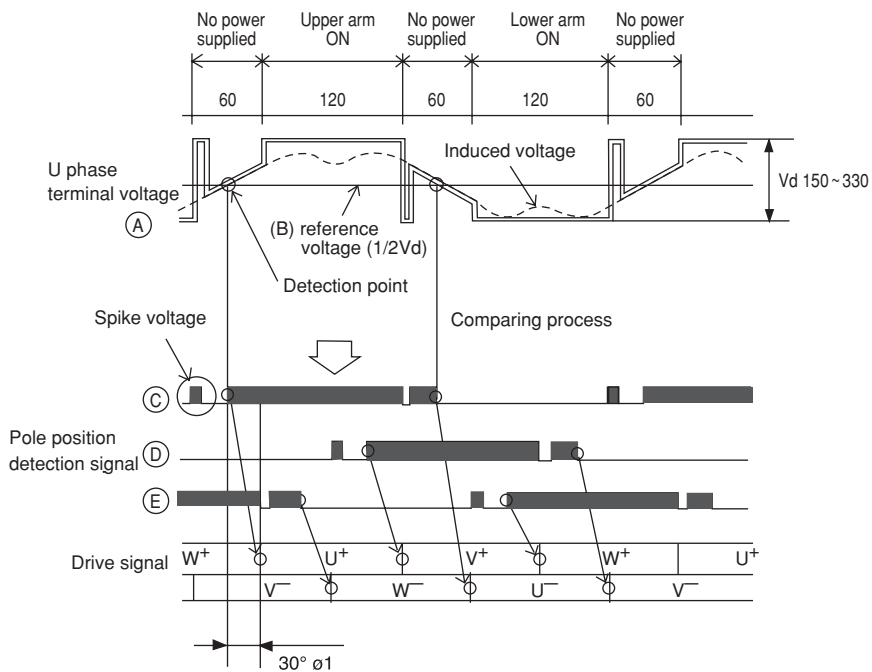
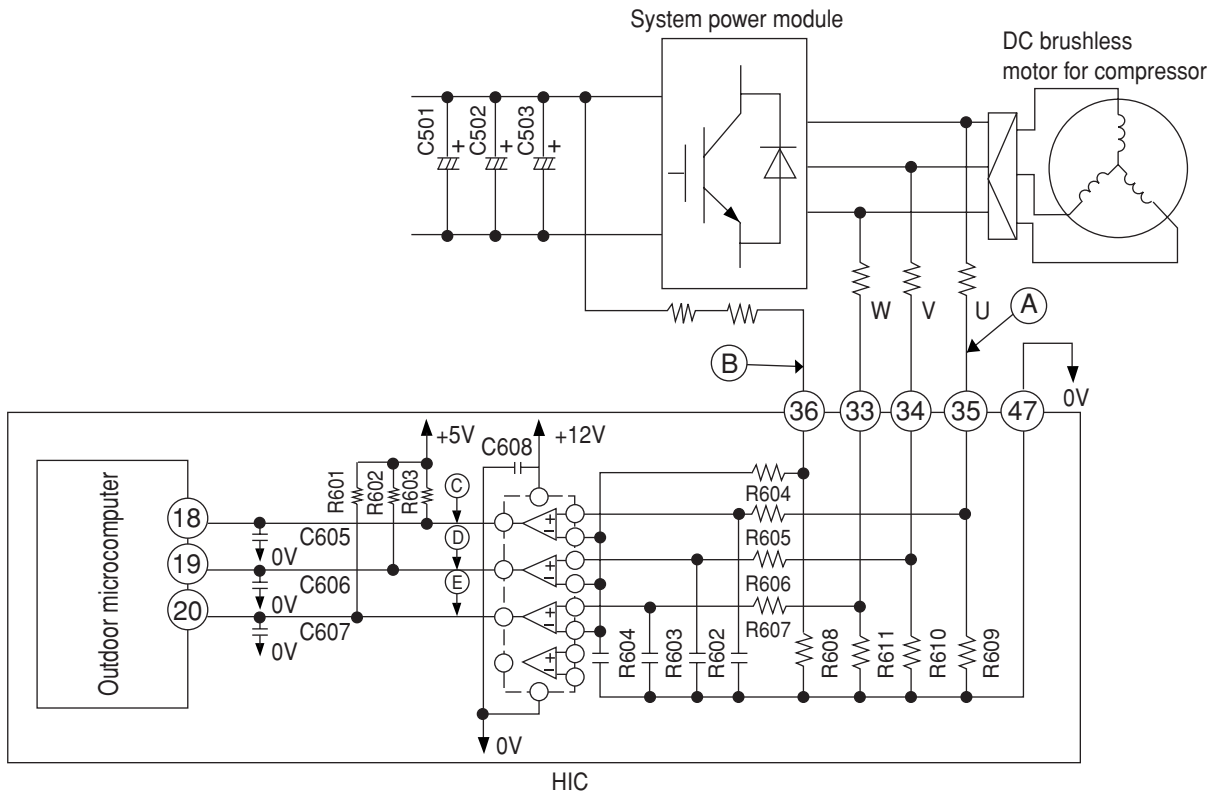

Fig. 6-1 Rotor magnetic pole position detection circuit and voltage waveform at each point

- To detect U phase, voltage at point © is produced by driving motor induced voltage signal (voltage at point (A)) and 1/2 voltage of V_d (voltage at point (B)), and comparing with comparator.
- For V phase and W phase, voltage at point (D) and voltage at point (E) are produced in the same way as above. Voltage at point © is taken into indoor unit microcomputer, switching timing to U^+ transistor from W^+ transistor is produced by delaying 30° from rise waveform, ignoring spike voltage. In addition, switching timing to U-transistor from W-transistor is produced by delaying 30° from fall waveform.
- For V phase and W phase, in the same way as above, drive signals are produced from voltages at point (D) and point (E). Phases are shifted by 120° and 240° , respectively, comparing with U phase.

[Low speed rotation mode]

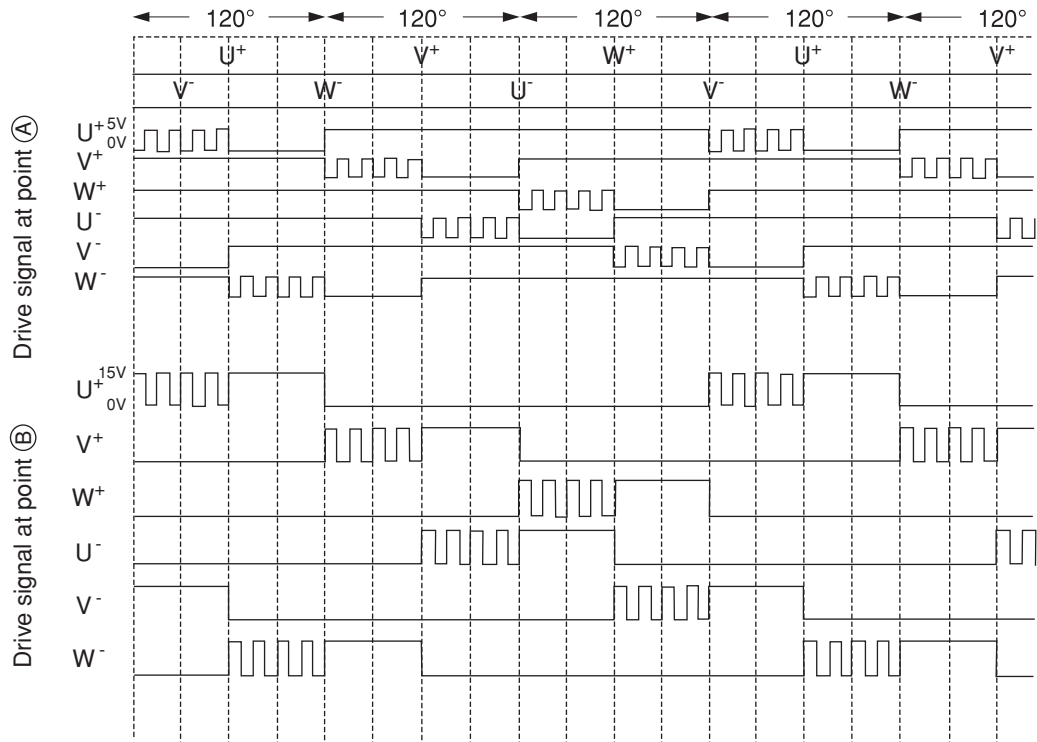

Fig. 7-2

[High speed rotation mode]

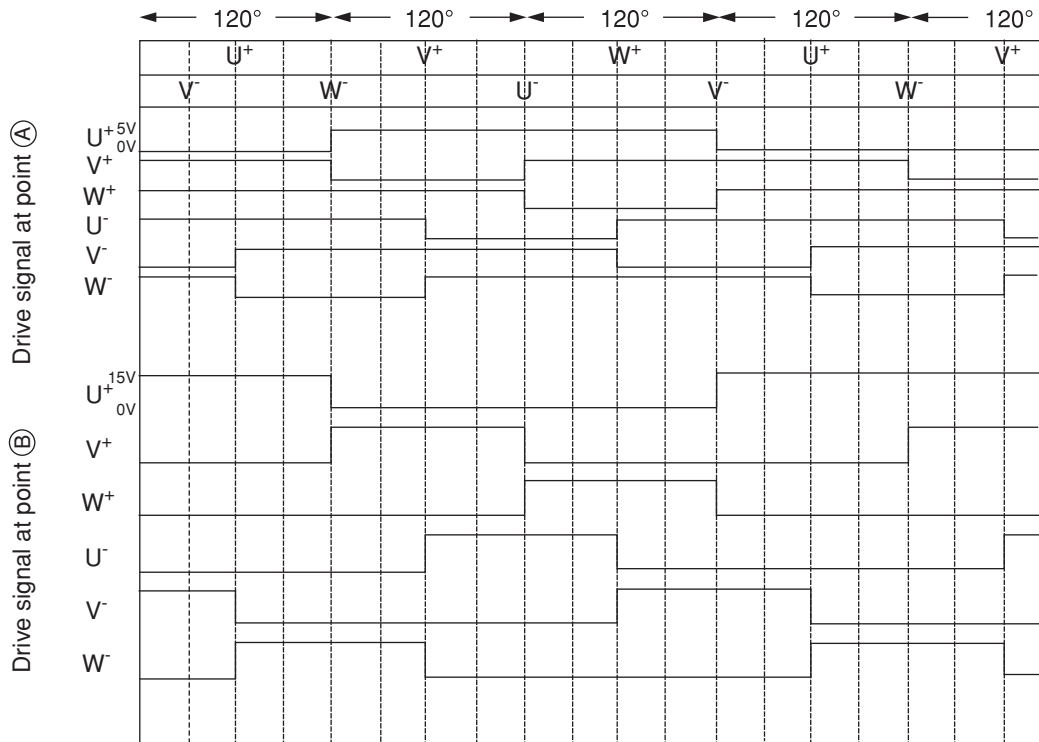

Fig. 7-3

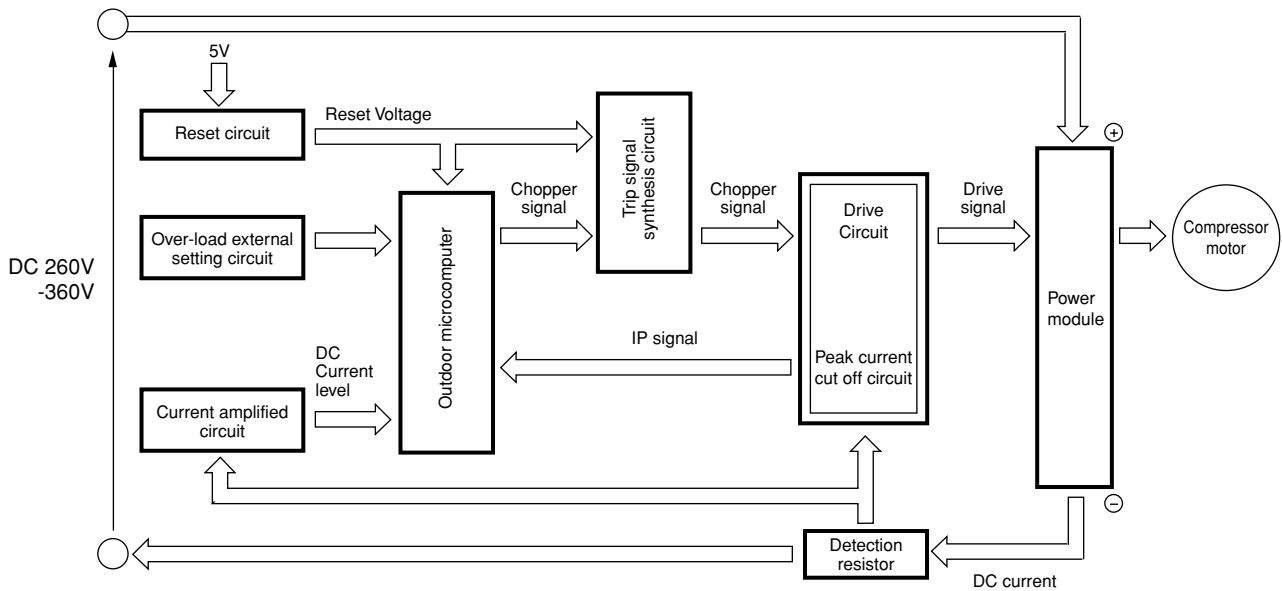

Fig. 8-2

- The following describes the operations of each circuit in detail.

(1) Peak current cut off circuit

Fig.8-3 Peak Current Cut off Circuit and Waveforms at Each Section.

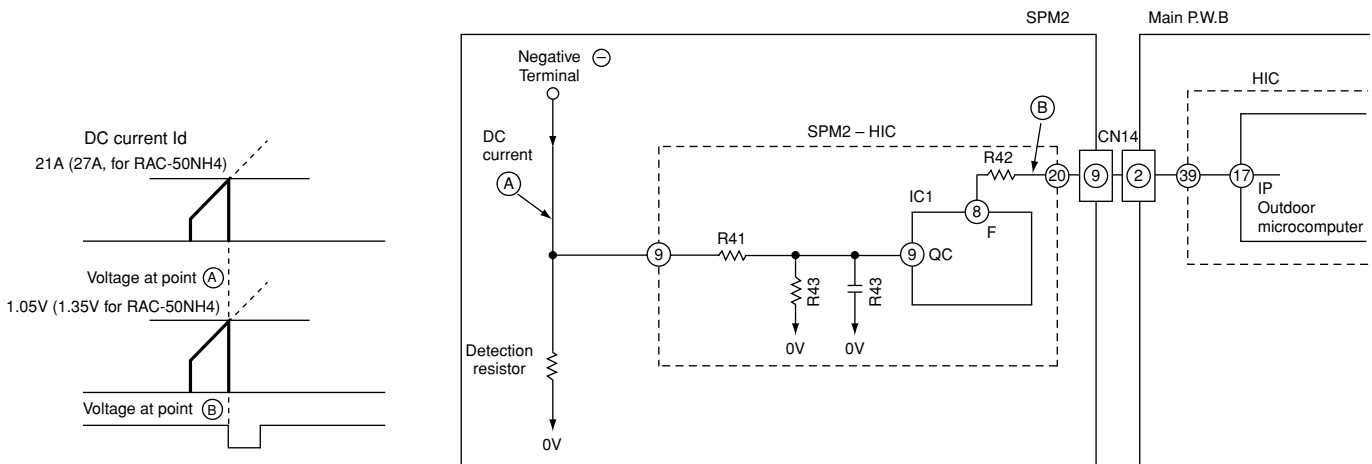

Fig.8-3

- The Ip cut off circuit detects an instantaneous excessive current and stops inverter to protect parts such as SPM2, etc.
- As shown in diagram, if current exceeding 21A (27A for RAC-50NH4) flows, voltage at point (A) recognized by detecting resistor is input to pin (10) of SPM2 – HIC, and voltage divided by R41 and R43 is input to pin (9) of IC1. Since threshold of IC1 is exceeded in this case, Lo signal is input from pin (8) (Voltage at point (B)). When Lo signal is input to pin (17) of microcomputer, microcomputer stops drive output.
- When drive output from microcomputer is stopped, all drive output goes Hi, and microcomputer is initialized to enter drive signal standby mode. 3 minutes later, microcomputer outputs drive signal again, to start operation.

(2) Overload control circuit (OVL control circuit)

- Overload control is to decrease the speed of the compressor and reduce the load when the load on the air conditioner increases to an overload state, in order to protect the compressor, electronic components and power breaker.
- Overloads are judged by comparing the DC current level and set value.
- Fig. 8-4 shows the overload control system configuration and Fig. 8-5 is a characteristic diagram of overload judgement values. There are two judgement methods-external judgement which compares the externally set value with the DC current value regardless of the rotation speed and internal judgement which compares the set value that varies according to the rotation speed programmed in the microcomputer software with the DC current value.

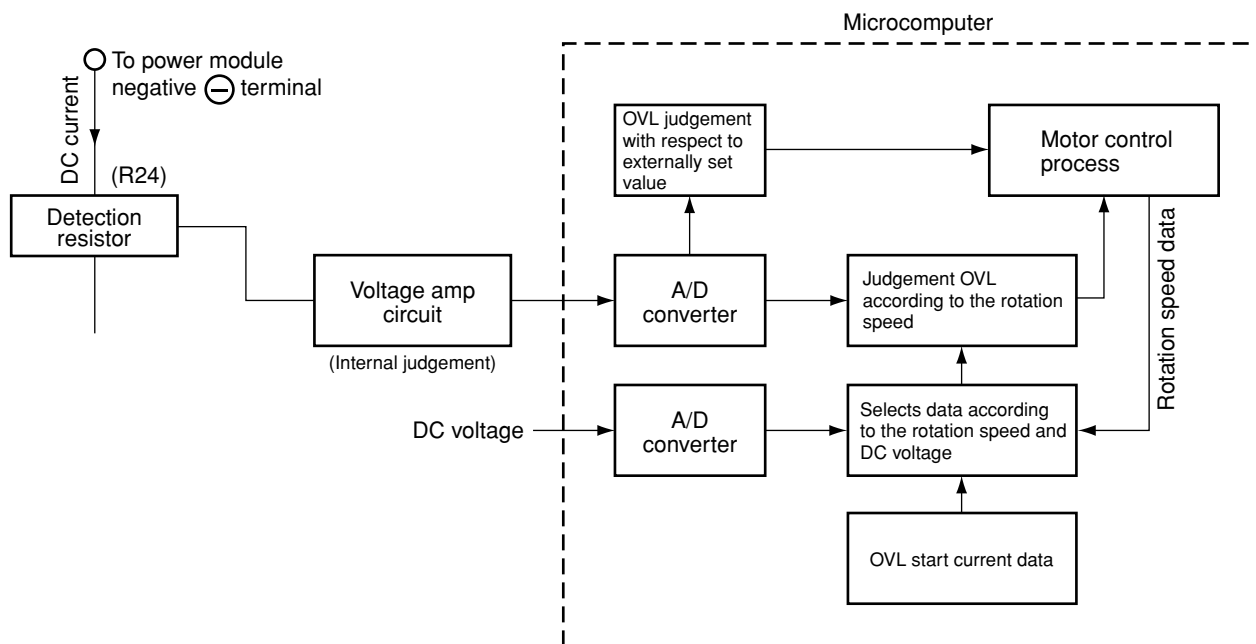

Fig. 8-4 Overload Control System Configuration

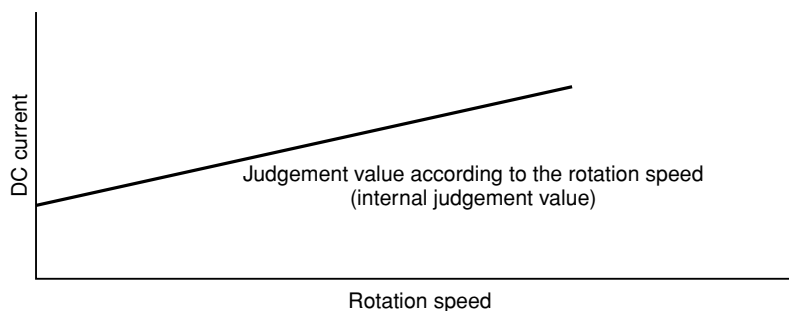

Fig. 8-5

①. Overload external judgement circuit

- Fig. 8-1. The filter consisting of R245 and C217 removes high harmonic components from the voltage generated by the current flowing to Detection resistor; R245 and C217 average the voltage. This voltage is then input to IC4 pin ⑤ is then amplified and supplied to microcomputer pin ⑩. The microcomputer compares this input with the internally set value, and if the input exceeds the set value, it enters overload control status.
- Fig. 8-7 shows the rotation speed control. When the voltage at pin ⑩ of the microcomputer exceeds the set value, the microcomputer decreases the rotation speed of the compressor and reduces the load regardless of the rotation speed commanded by the indoor microcomputer.

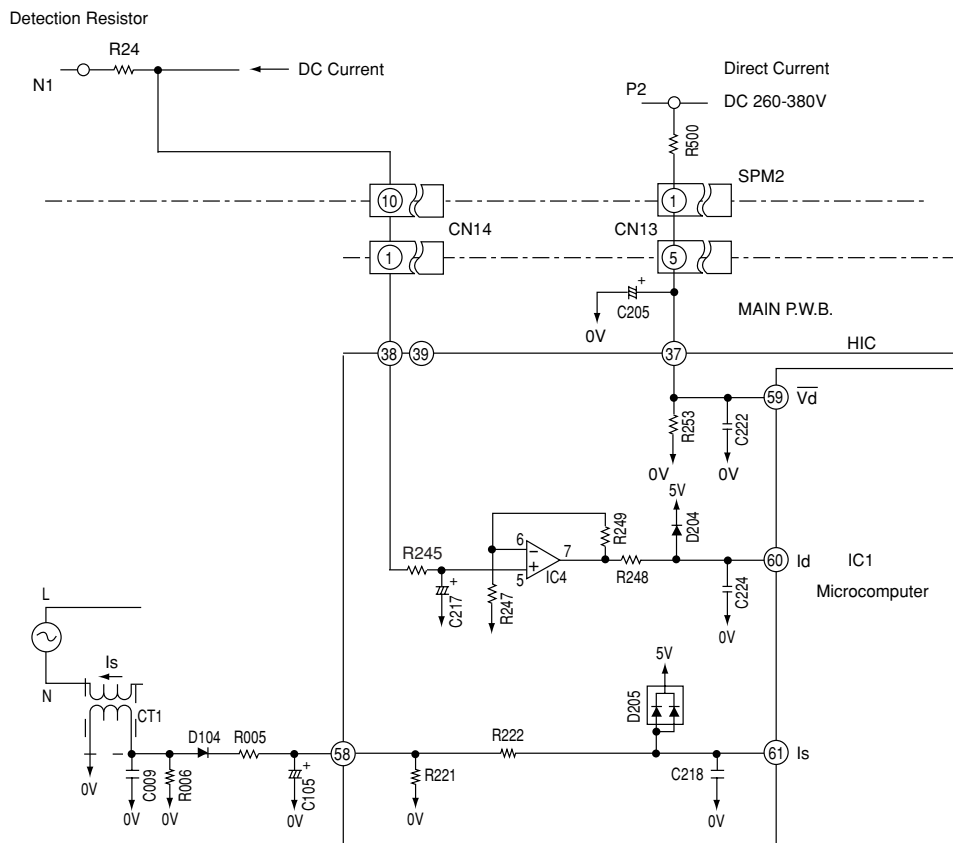

Fig. 8-6

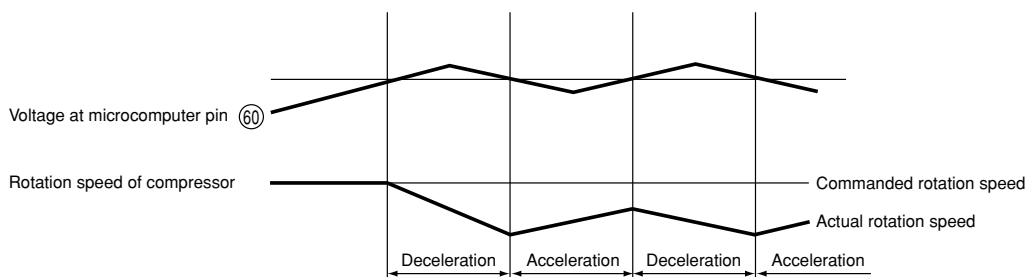

Fig. 8-7

②. Voltage amp. circuit

- The voltage amp. circuit amplifies the DC current level detected by the detection resistor after being converted to a voltage and supplies it to the microcomputer. Receiving this, the microcomputer converts it to a digital signal and compares it with the internal data to judge whether or not overload control is required.

< During overload control >

- The filter consisting of R245 and C217 removes high harmonic components from the voltage generated from the DC current flowing to the detection resistor, and supplies it to IC4 pin ⑤ IC4 forms a non-inverting voltage amp. circuit together with the peripheral elements.
- The microcomputer stores the set values which vary according to the rotation speed. When the DC current level exceeds the set value, the microcomputer enters the overload control state.
- The set Value is determined by the amplification of the voltage amp. circuit.

- Amplification : high → DC current : low
- Amplification : low → DC current: high

- R500, R253, detect the DC voltage at the power circuit. The microcomputer receives a DC voltage (260-380V) via HIC ③7 and applies correction to the overload set value so the DC current is low (high) when the DC voltage is high (low).

(Since the load level is indicated by the DC voltage multiplied by DC current, R247, R248, R249 are provided to perform the same overload judgement even when the voltage varies.)

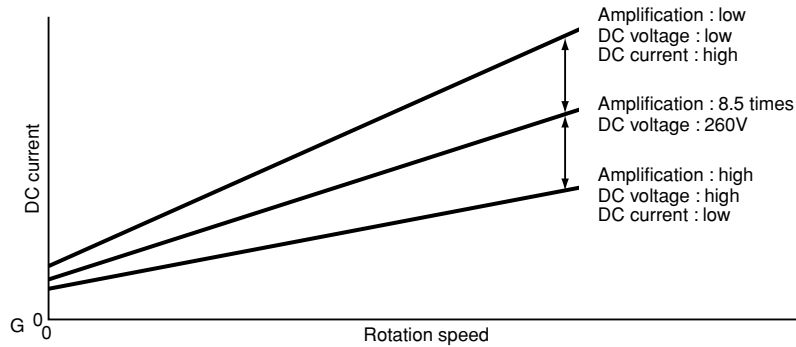

Fig. 8-8

< During start current control >

- It is required to maintain the start current (DC current) constant to smooth the start of the DC motor for the compressor.
- RAC-25NH4, RAC-35NH4, RAC-50NH4 uses software to control the start current.
- The start current varies when the supply voltage varies. This control method copes with variations in the voltages as follows.

(1) Turns on the power module's U⁺ and V⁻ transistors so the current flows to the motor windings as shown in Fig8-9.

(2) Varies the turn-ON time of the W⁺ transistor according to the DC voltage level and the start is controlled so the start current is approx. 10A as shown in Fig. 8-10.

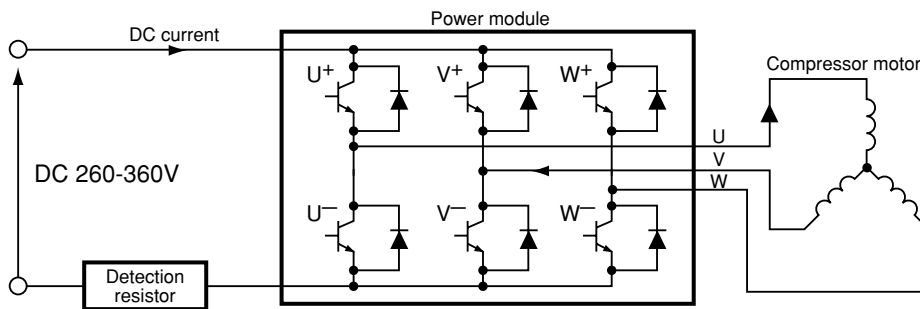

Fig. 8-9

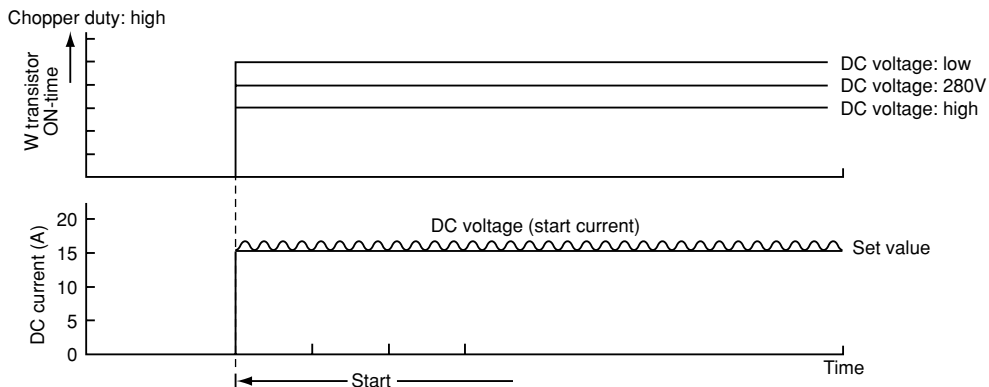

Fig. 8-10

9. Temperature Detection Circuit

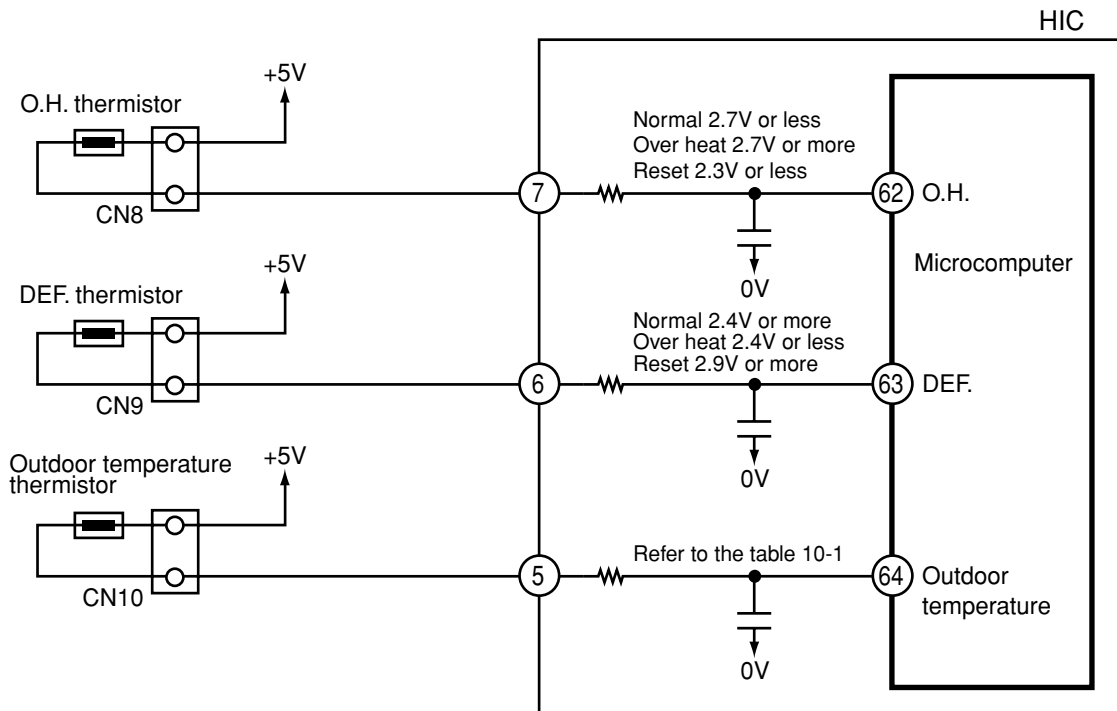

Fig. 9-1

- The Over heat thermistor circuit detects the temperature at the surface of the compressor head, the Defrost. thermistor circuit detects the defrosting operation temperature.
- A thermistor is a negative resistor element which has the characteristics that the higher (lower) the temperature, the lower (higher) the resistance.
- When the compressor is heated, the resistance of the Over heat thermistor becomes low and voltage at pin ⑥② of microcomputer is increased.
- Microcomputer compares the voltage present at pin ⑥② with the internal set value, if it is exceeded the set value microcomputer judges that the compressor is overheated and stops operation.
- When frost forms on the outdoor heat exchanger, the temperature at the exchanger drops abruptly. Therefore the resistance of the Defrost. thermistor becomes high and the voltage at pin ⑥③ of microcomputer drops. If this voltage becomes lower than the set value stored inside, the microcomputer starts defrosting control.
- During defrosting operation the microcomputer transfers the defrosting condition command to the indoor microcomputer via the circuit interface.
- The microcomputer always reads the outdoor temperature via a thermistor (microcomputer pin ⑥④), and transfers it to the indoor unit, thus controlling the compressor rotation speed according to the value set at the EEPROM in the indoor unit, and switching the operation status (outdoor fan on/off, etc.) in the dry mode.

The following shows the typical values of outdoor temperature in relation to the voltage:

Table 9-1

Outdoor temperature (°C)	-10	0	10	20	30	40
Microcomputer pin ⑤ voltage (V)	1.19	1.69	2.23	2.75	3.22	3.62

<Reference>

When the thermistor is open, in open status, or is disconnected, microcomputer pins ⑥②–⑥④ are approx. 0V; when the thermistor is shorted, they are approx. 5 V, and LD301 blinks seven times.

However, an error is detected only when the OH thermistor is shorted; in such a case, the blinking mode is entered 12 minutes after the compressor starts operation.

10. Reset Circuit

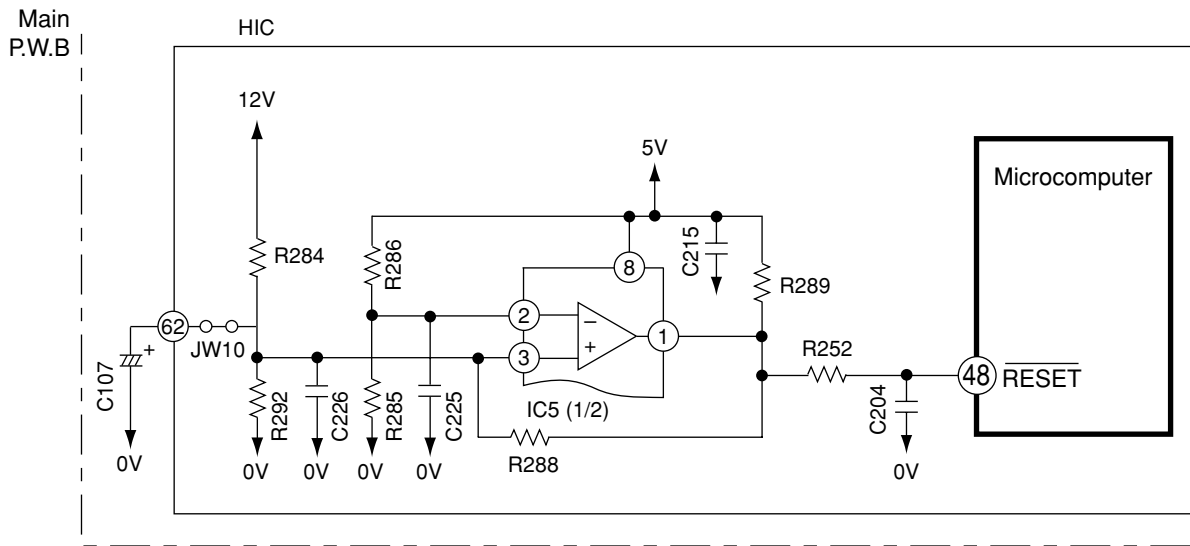

Fig. 10-1

- The reset circuit initializes the microcomputer program when Power is "ON" or "OFF".
- Low voltage at pin (48) resets the microcomputer, and HI activates the microcomputer.
- Fig. 10-1 shows the reset circuit and Fig. 10-2 shows waveform at each point when power is turned on and off.
- When power is turned on, 12V line and 5V line voltages rise and 12V line voltage reaches 10.9V and reset voltage input to pin (48) of microcomputer is set to Hi.
- Reset voltage will be hold "Hi" until the 12V line voltage drops to 9.90V even though the power shuts down.

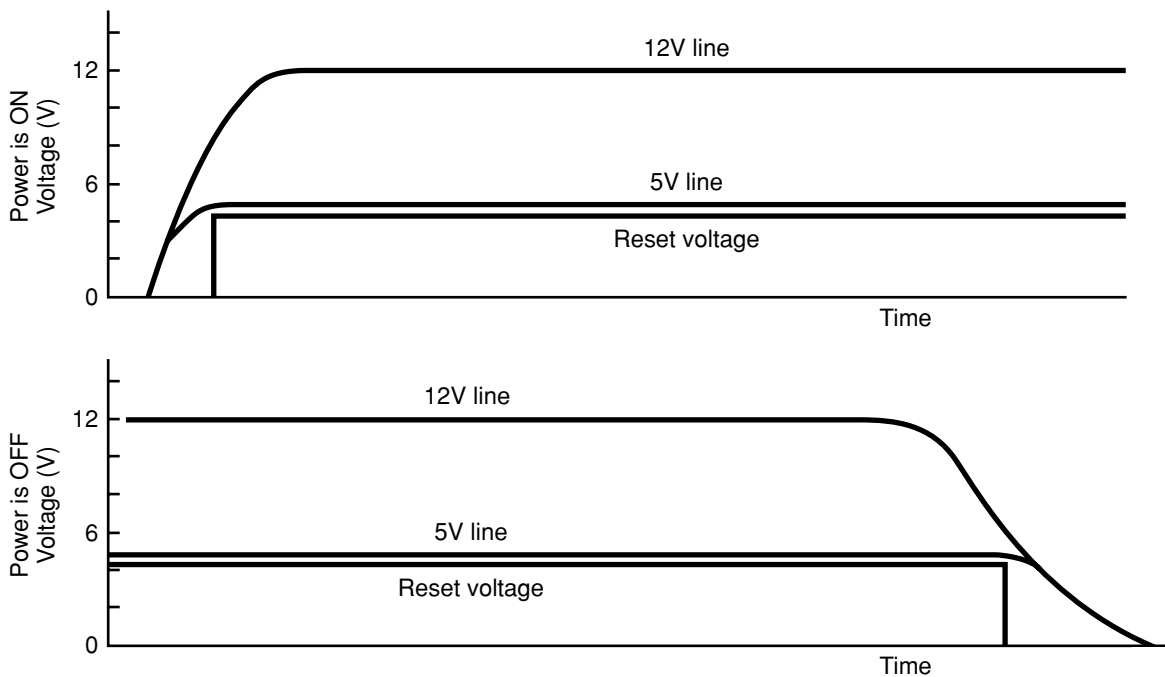

Fig. 10-2

11. Outdoor DC Fan Motor control circuit.

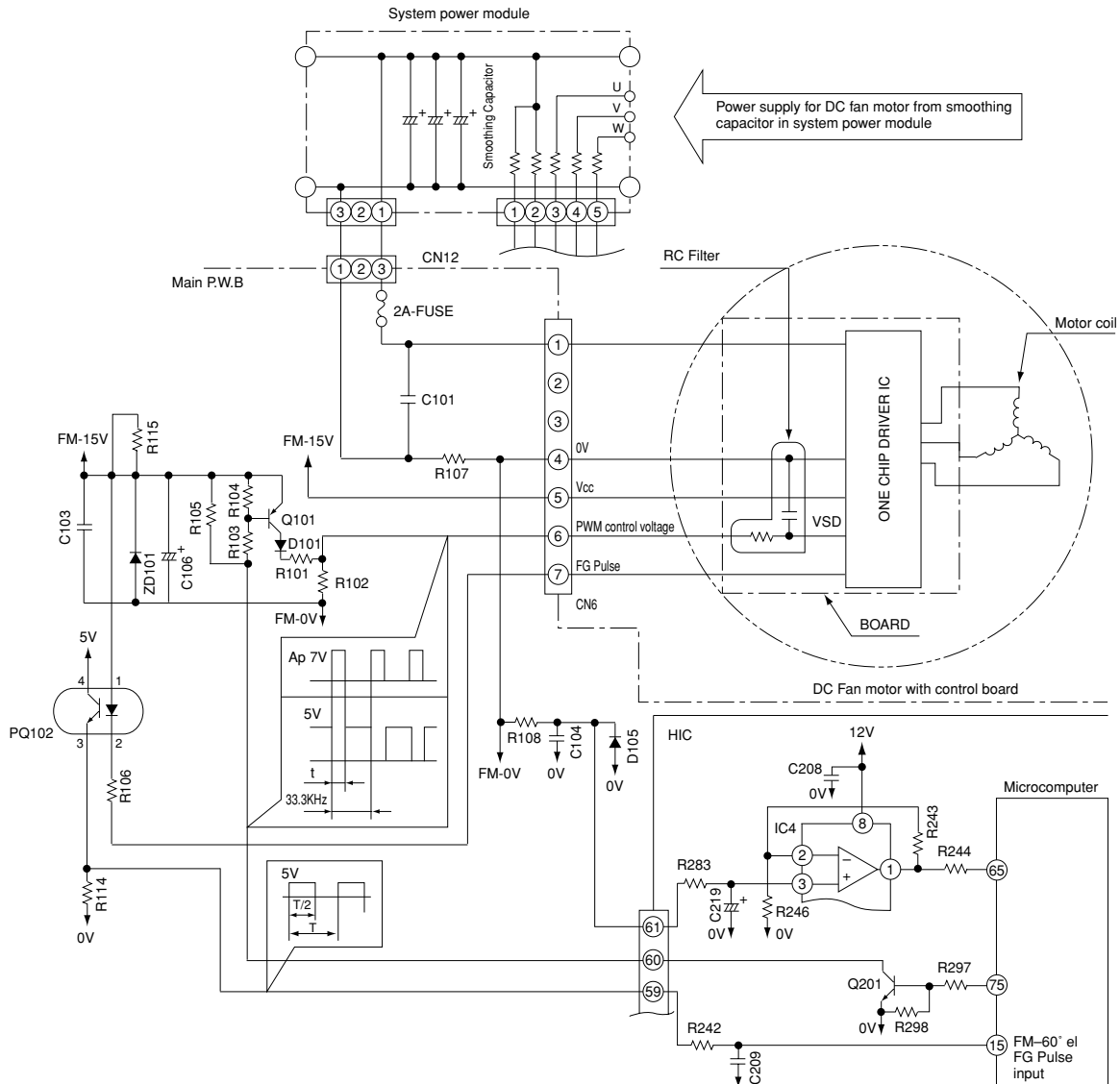

Fig. 11-1

- This model uses DC Fan Motor which has a controller circuit in the Motor.
- This DC Fan Motor will rotate by control voltage apply to Vsp input. (Voltage range: 1.7 to 7V DC)
Vsp high : Faster ; Vsp low : slower ; Vsp lower than 1.7V : stop
- Motor will output FG pulse by following this motor revolution.
- Outdoor Microprocessor will output PWM control signal from FMCHOP terminal by following the instruction from indoor Microprocessor.
- This PWM control signal will convert to Vsp voltage by smoothing circuit (Q101 & RC filter)
- Fan motor will start to rotate when Vsp was proceeding over than 1.7V, and generate FG pulse by rotation speed.
- FG pulse will feed back to Outdoor Microprocessor through PQ102.
- PQ102 is the isolator between Microprocessor circuit and DC Fan Motor circuit, which has to match the Fan Motor revolution with instructed revolution. Such as...
FG feedback: Faster – Instruction: Slower ... Decrease pulse width
FG feedback: Slower – Instruction: Faster ... Increase pulse width
- FG pulse is also used for Fan Motor failure detection
- Microprocessor will monitor FG pulse 30 seconds after start the fan motor. If there is no signal detected, it will consider that the Fan Motor was malfunction and stop the operation. In this case, LD302 on control PWB will blink 12 times. (Fan Motor lock detected)
- R107 and IC4 are used for Fan Motor over current

< Reference >

- When operation stop with LD301 blinks 12 times, it may be caused by faulty DC fan motor.
- In this case, please check CN6 and CN12 connection first. It makes Fan Motor Lock also if those connectors are in misconnection.
- DC Fan Motor has broken when 2A Fuse was burned. Please replace both DC Fan Motor and 2A Fuse together.
- It will makes "Fan Lock Stop" when something has disturb the Fan rotation by inserting materials into propeller fan or ice has growing inside of outdoor unit by snowing.
- It may make "Fan Lock Stop" by strong wind (ex. 17m/sec or above) against the Fan rotation. In this case, unit will be restart again after a while.
- In case of "Fan Lock Stop" even though the DC Fan Motor is rotating correctly, the possible casue is Fan Motor problem or PQ102 on board or control board problem. Stop after the Fan motor runs 2 minutes, Fan Motor may be broken.

< Caution >

- Please take care for the electrical shock by high voltage of DC Fan Motor power source which is common with compressor when you are servicing this unit.
- You can not confirm the coil and wiring of Motor due to the built in control circuit in Fan Motor.

12. Power Factor Control Circuit

Power factor is controlled to almost 100%. (Effective use of power)

With IC in ACT module, control is performed so that input current waveform will be similar to waveform of input voltage

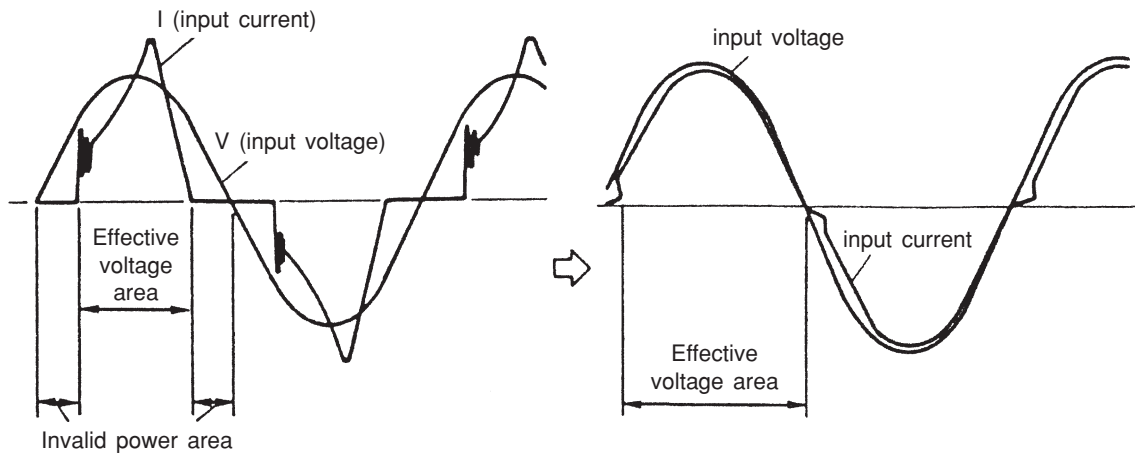

(Even if voltage is applied, current does not flow)

* Assuming the same current capacity (20A), power can be used about 10% effective, comparing with current use (power factor of 90%), and maximum capacity is thereby improved.

SERVICE CALL Q & A

Model RAI-25NH4
RAI-40NH4

COOLING MODE

Q1 The compressor has stopped suddenly during cooling operation.



A1 Check if the indoor heat exchanger is frosted. Wait for 3-4 minutes until it is defrosted.

If the air conditioner operates in cooling mode when it is cold, the evaporator may get frosted.

DEHUMIDIFYING MODE

Q2 Sound of running water is heard from indoor unit during dehumidifying.



A2 Normal sound when refrigerant flows in pipe.

Q3 Compressor occasionally does not operate during dehumidifying.



A3 Compressor may not operate when room temperature is 10°C or less. It also stops when the humidity is preset humidity or less.

HEATING MODE

Q4 The circulation stops occasionally during Heating mode.



A4 It occurs during defrosting. Wait for 5-10 minutes until the condenser is defrosted.

Q5 When the fan speed is set at HIGH or MED, the flow is actually Weak.



A5 At the beginning of heating, the fan speed remains LOW for 30 seconds. If HIGH is selected, it switches to LOW and again to MED after additional 30 seconds.

Q6 Heating operation stops while the temperature is preset at "30".



A6 If temperature is high in the outdoor, heating operation may stop to protect internal devices.

AUTO FRESH DEFROSTING

Q7) After the ON/OFF button is pressed to stop heating, the outdoor unit is still working with the OPERATION lamp lighting.



A7) Auto Fresh Defrosting is carried out : the system checks the outdoor heat exchanger and defrosts it as necessary before stopping operation.

AUTO OPERATION

Q8) Fan speed does not change when fan speed selector is changed during auto operation.



A8) At this point fan speed is automatic.

NICE TEMPERATURE RESERVATION

Q9) When on-timer has been programmed, operation starts before the preset time has been reached.



A9) This is because "Nice temperature reservation" function is operating. This function starts operation earlier so the preset temperature is reached at the preset time. Operation may start maximum 60 minutes before the preset time.

Q10) Does "Nice temperature reservation" function operate during dehumidifying?



A10) It does not work. It works only during cooling and heating.

Q11) Even if the same time is preset, the operation start time varies.



A11) This is because "Nice temperature reservation" function is operating. The start time varies according to the load of room. Since load varies greatly during heating, the operation start time is corrected, so it will vary each day.

INFRARED REMOTE CONTROL

Q12) Timer cannot be set.



A12) Has the clock been set? Timer cannot be set unless the clock has been set.

Q13) The current time display disappears soon.



A13) The current time disappears in approx. 10 seconds. The time set display has priority.

When the current time is set the display flashes for approx 3 minutes.

Q14) The timer has been programmed, but the preset time disappears.



A14) Is the current time past the preset time? When the preset time reaches the current time, it disappears.

OTHERS

Q15 The indoor fan varies among high air flow, low air flow and breeze in the auto fan speed mode. (Heating operation)



A15 This is because the cool wind prevention function is operating, and does not indicate a fault.

The heat exchanger temperature is sensed in the auto speed mode. When the temperature is low, the fan speed varies among high air flow, low air flow and breeze.

Q16 Loud noise from the outdoor unit is heard when operation is started.



A16 When operation is started, the compressor rotation speed goes to maximum to increase the heating or cooling capability, so noise becomes slightly louder. This does not indicate a fault.

Q17 Noise from the outdoor unit occasionally changes.



A17 The compressor rotation speed changes according to the difference between the thermostat set temperature and room temperature. This does not indicate a fault.

Q18 There is a difference between the set temperature and room temperature.



A18 There may be a difference between the set temperature and room temperature because of construction of room, air current, etc. Set the temperature at a comfortable for the space.

Q19 Air does not flow immediately after operation is started.



A19 Preliminary operation is performed for one minute when the power switch on and heating or dehumidifying is set. The operation lamp blinks during this time for heating. This does not indicate a fault.

TROUBLE SHOOTING

Model RAI-25NH4
RAI-40NH4

PRECAUTIONS FOR CHECKING



- Remember that the 0V line is biased to 155-170V in reference to the ground level.
- Also note that it takes about 10 minutes until the voltage fall after the power switch is turned off.

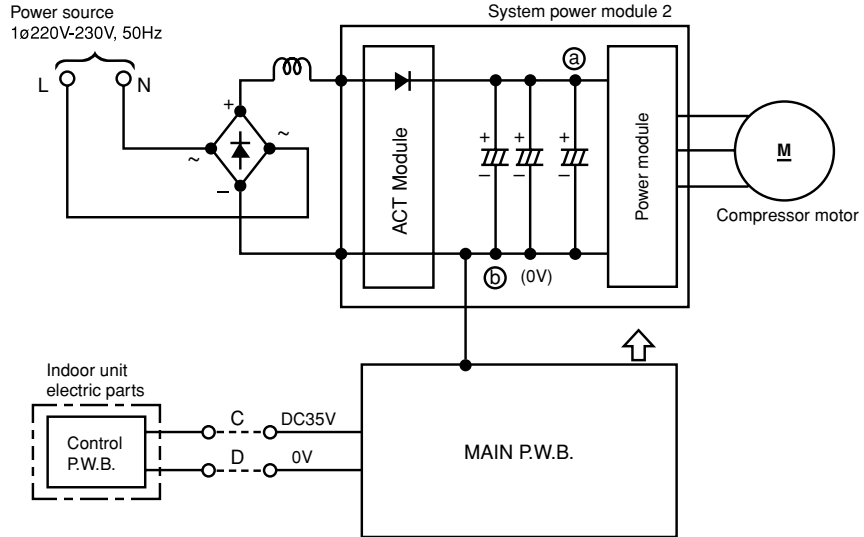

Across (a) – (b) (0V line)..... approx 260-360V
 Across (a) – ground..... approx 155-170V
 Across (b) (0V line)– ground..... approx 155-170V



When using an oscilloscope, never ground it. Don't forget that high voltages as noted above may apply to the oscilloscope.

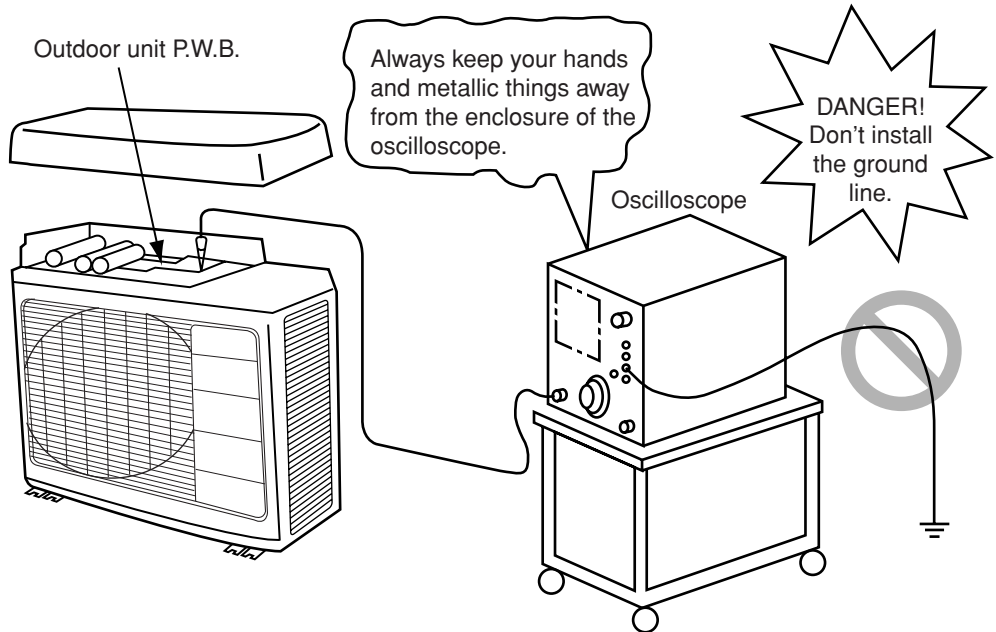

DISCHARGE PROCEDURE AND POWER SHUT OFF METHOD FOR POWER CIRCUIT



WARNING

Caution

- Voltage of about 300-330V is charged between both ends of smoothing capacitors
- During continuity check for each part of circuit in indoor unit electrical parts, disconnect red/gray lead wire connected from diode stack to system power module (SPM2) to prevent secondary trouble. (Be sure to discharge smoothing capacitor)

1. Turn OFF the Power supply to the outdoor unit.
2. After power is turned off, wait for 10 minutes or more. Then, remove electrical parts cover and apply soldering iron of 30 to 75W for 15 seconds or more to P2 and N1 terminals on system power module, in order to discharge voltage in smoothing capacitor.
3. Remove receptacle of red/gray lead wire connected to system power module from diode stack before performing operation check of each circuit.

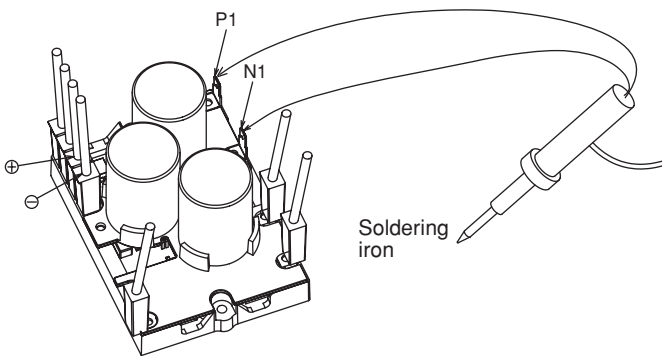

System power module

Do not use a soldering iron with transformer: If one is used, thermal fuse inside transformer will be blown

As shown above, apply soldering iron to metal parts (receptacle) inside the sleeve corresponding to P1 and N1 terminals of system power module: Do this with smoothing capacitors kept connected. By removing red/gray lead wire from diode stack, power supply can be shut off. (corresponding to ⊕ and ⊖ terminals of system power module)

RAC-25NH4

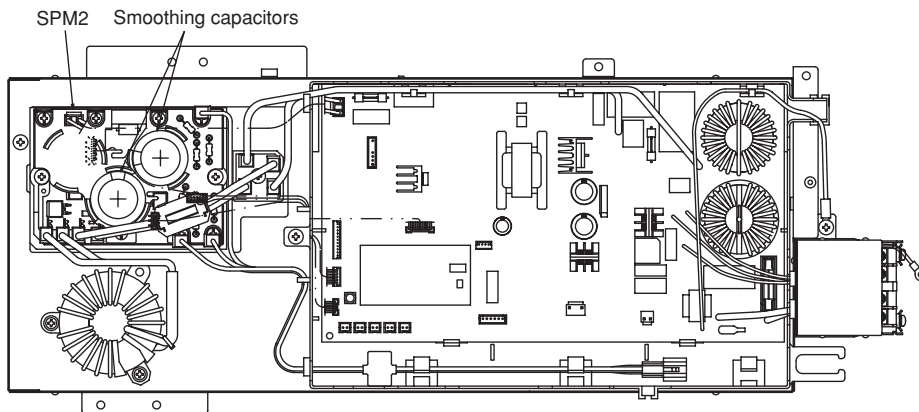

RAC-50NH4

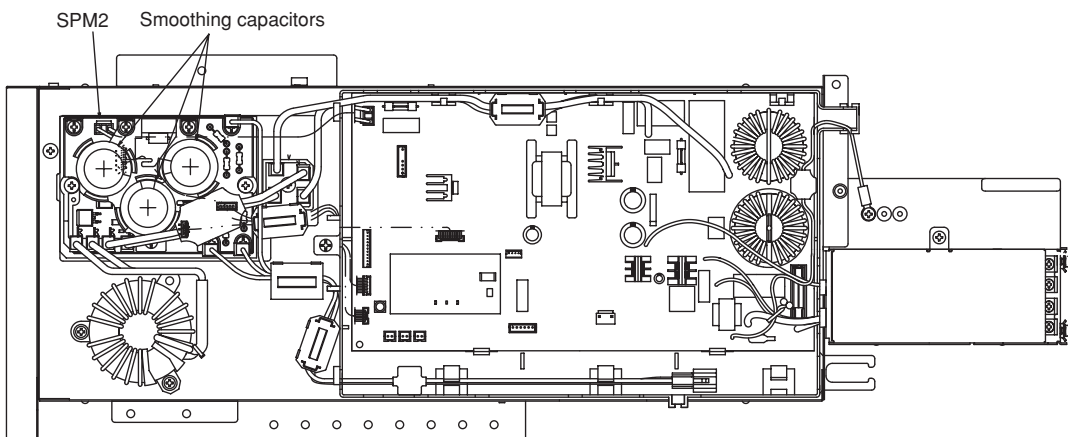

CHECKING THE INDOOR/OUTDOOR UNIT ELECTRICAL PARTS AND REFRIGERATING CYCLE

Model **RAI-25NH4**
RAI-40NH4

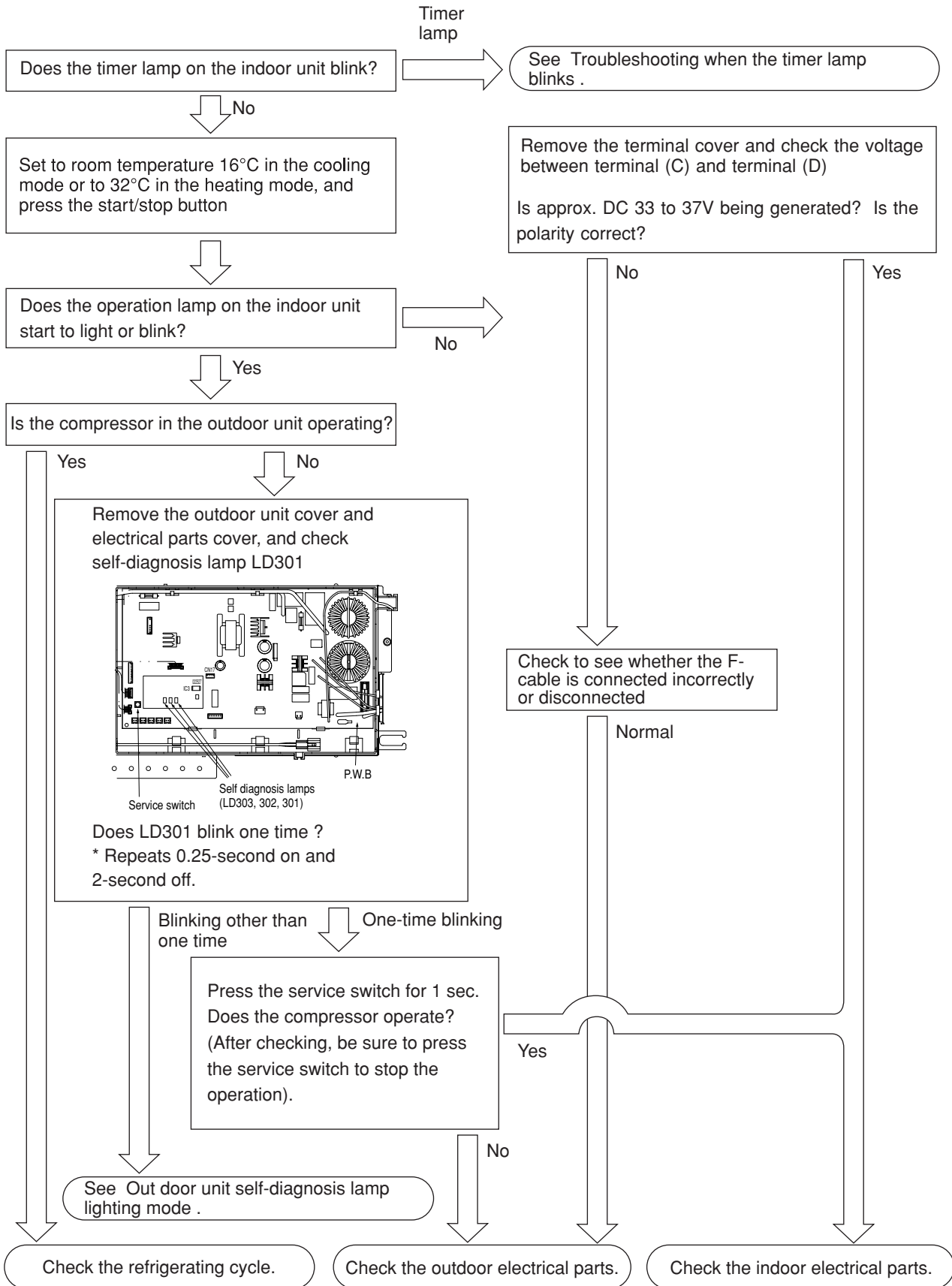







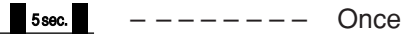
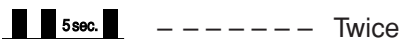

TROUBLESHOOTING WHEN TIMER LAMP BLINKS.

Model RAI-25NH4, RAI-40NH4

Perform troubleshooting according to the number of times the indoor timer lamp and outdoor LD301 blink.

SELF-DIAGNOSIS LIGHTING MODE

Model: RAI-25NH4, RAI-40NH4

No.	Timer indicator flashing mode	Reason for display	Section of estimated fault
1	 Once	Four-way valve faulty The room heat exchange temperature is low during heating, or it is high during cooling.	(1) Four-way valve faulty. (2) Disconnection in heat exchange thermistor (only during heating)
2	 Twice	Outdoor unit forced operation The outdoor unit is in forced operation or undergoing balancing after forced operation.	Service SW in outdoor electrical parts turned ON.
3	 3 times	Indoor/outdoor interface faulty The interface signal from the outdoor unit has been interrupted.	(1) Indoor interface circuit (2) Outdoor interface circuit
4	 -- 4 times	Outdoor electrical assembly defective.	Please check at the outdoor electrical led lamp blinking (LD301) and refer to self diagnosis lighting mode for outdoor unit.
5	 -- 6 times	Abnormal water level detection All stop when the float switch has been activated.	(1) Drain stopped up (2) Drain pump (3) Float switch
6	 -- 7 times	Drain pump forced operation. When the knob of drain pump test switch at Indoor P.W.B main slide to 'test' position.	(1) Indoor P.W.B. Main.
7	 -- 9 times	Room thermistor or heat exchanger thermistor is faulty When room thermistor or heat exchanger thermistor is opened circuit or short circuit.	(1) Room thermistor (2) Heat exchanger thermistor
8	 -- 10 times	DC fan motor overcurrent detection Overcurrent in indoor DC fan motor has been detected.	(1) Indoor fan locked (2) Indoor fan motor (3) Indoor P.W.B. Main
※1 9	 -- 13 times	IC401 data reading fault There was error in the data read from IC401	IC401 faulty

( -- Lights for 0.5 sec. at interval of 0.5 sec..)

<Cautions>

- (1) If the interface circuit is faulty when power is supplied, the self-diagnosis display will not be displayed.
- (2) If the indoor unit does not operate at all, check to see if the F-cable is connected or disconnected.
- (3) To check operation again when the timer lamp is blinking, you can use the remote control for operation (except for mode mark ※1).

SELF-DIAGNOSIS LIGHTING MODE

MODEL: RAI-25NH4, RAI-40NH44



DANGER (DC360V)

- SWITCH OFF MAIN POWER SUPPLY TO THE OUTDOOR UNIT AT LEAST 10 MINUTES BEFORE START THE SERVICING WORK.
- MAKE SURE THE DC VOLTAGE LEVEL AT MEASURING POSITION (P1) AND (N1) IS LESS THAN 10V.
- DO NOT TOUCH THE SCREWS OF THE SYSTEM POWER MODULE WHEN THE UNIT IS TURNED ON. HIGH VOLTAGE STILL REMAIN EVEN AFTER THE UNIT IS TURNED OFF.
- DO NOT TOUCH ANY OTHER PARTS EXCEPT THE SERVICE SWITCH WHEN SERVICE OPERATION IS CONDUCTED.

SELF-DIAGNOSIS LIGHTING MODE ■ LIT ■ BLINKING □ OFF

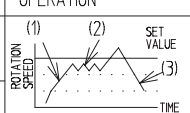
LD301	LD302	SELF-DIAGNOSIS NAME	DETAILS	MAIN CHECK POINT
<input type="checkbox"/>	<input type="checkbox"/>	[1] DURING OPERATION	COMPRESSOR OPERATION	LD303 LIGHTS, ■
<input type="checkbox"/>	<input type="checkbox"/>	NORMAL OPERATION	COMPRESSOR OPERATION	NOT MALFUNCTION
<input checked="" type="checkbox"/>	<input type="checkbox"/>	OVERLOAD (1)	 <p>UNDER OVERLOAD CONDITION, THE ROTATION SPEED IS CONTROLLED AUTOMATICALLY IN ORDER TO PROTECT THE COMPRESSOR.</p>	THIS SHOWS AN OVERLOAD, NOT MALFUNCTION.
<input type="checkbox"/>	<input checked="" type="checkbox"/>	OVERLOAD (2)		
<input checked="" type="checkbox"/>	<input checked="" type="checkbox"/>	OVERLOAD (3)		

LIGHT	DURING STOP	DESCRIPTION
<input type="checkbox"/>	<input type="checkbox"/>	NORMAL STOP INDOOR THERMOSTAT OFF. MAIN OPERATION OFF. NOT MALFUNCTION.
<input checked="" type="checkbox"/>	<input type="checkbox"/>	RESET STOP WHEN STOPPED WITH POWER RESET. (NORMAL WHEN POWER HAS BEEN TURNED ON). ① P.W.B.s (POWER CIRCUIT, HIC, ETC.)
<input checked="" type="checkbox"/>	<input type="checkbox"/>	PEAK CURRENT CUT OVER CURRENT IS DETECTED. ① SYSTEM POWER MODULE ② COMPRESSOR ③ P.W.B.s
<input checked="" type="checkbox"/>	<input type="checkbox"/>	ABNORMAL LOW SPEED ROTATION POSITION DETECTION SIGNAL IS NOT INPUT DURING OPERATION. ① SYSTEM POWER MODULE ② COMPRESSOR ③ P.W.B.s
<input checked="" type="checkbox"/>	<input type="checkbox"/>	SWITCHING FAILURE FAIL TO SWITCH FROM INITIAL LOW FREQUENCY SYNC. TO POSITION DETECTION SYNC.. ① SYSTEM POWER MODULE ② COMPRESSOR ③ P.W.B.s
<input checked="" type="checkbox"/>	<input type="checkbox"/>	OVERLOAD LOWER LIMIT CUT OVERLOAD CONDITION STILL PERSISTING EVEN WHEN ROTATION SPEED IS BELOW THE LOWER RPM LIMIT. ① OUTDOOR UNIT IS EXPOSED TO DIRECT SUNLIGHT OR ITS AIRFLOW BLOCKED. ② FAN MOTOR ③ FAN MOTOR CIRCUIT ④ THE VOLTAGE IS EXTREMELY LOW.
<input checked="" type="checkbox"/>	<input type="checkbox"/>	OH THERMISTOR OH THERMISTOR IS OPERATING. ① LEAK OF REFRIGERANT ② COMPRESSOR ③ OH THERMISTOR CIRCUIT ④ FAN MOTOR ⑤ FAN MOTOR CIRCUIT
<input checked="" type="checkbox"/>	<input type="checkbox"/>	TEMP. RISE THERMISTOR IS OPENED OR SHORTED. ① THERMISTOR ② CONNECTION OF THERMISTOR IS FAULTY ③ THERMISTOR CIRCUIT
<input checked="" type="checkbox"/>	<input type="checkbox"/>	ABNORMAL THERMISTOR
<input checked="" type="checkbox"/>	<input type="checkbox"/>	ACCELERATION DEFECTIVE NO ACCELERATION ABOVE THE LOWER LIMIT OF THE ROTATION SPEED. ① LEAK OF REFRIGERANT ② COMPRESSOR
<input checked="" type="checkbox"/>	<input type="checkbox"/>	COMMUNICATION ERROR COMMUNICATION BETWEEN INDOOR UNIT AND OUTDOOR UNIT ARE INTERRUPTED. ① C, D CABLE IS REVERSED ② CABLE IS DISCONNECTED ③ INTERFACE CIRCUIT OF INDOOR AND OR OUTDOOR UNIT
<input checked="" type="checkbox"/>	<input type="checkbox"/>	POWER SUPPLY VOLTAGE ERROR POWER SUPPLY VOLTAGE IS INCORRECT. ① RECEPTACLE OF WIRE AT SYSTEM POWER MODULE IS NOT PROPERLY INSERTED
<input checked="" type="checkbox"/>	<input type="checkbox"/>	FAN LOCK ERROR OUTDOOR FAN RPM IS NOT ROTATE AS INTENDED RPM. ① FAN MOTOR ② FAN MOTOR CIRCUIT
<input checked="" type="checkbox"/>	<input type="checkbox"/>	EEPROM READING ERROR MICROCOMPUTER CANNOT READ THE DATA IN EEPROM. ① HIC
<input checked="" type="checkbox"/>	<input type="checkbox"/>	ACTIVE CONVERTER DEFECTIVE OVER VOLTAGE IS DETECTED BY SYSTEM POWER MODULE. ① SYSTEM POWER MODULE

* EXAMPLE OF BLINKING (5 TIMES) ■■■■■ 2SEC (■■■■■ • LIGHTS FOR 0.25 SEC. AT INTERVAL OF 0.25 SEC.)

WIRING DIAGRAM

BLK : BLACK GRY : GRAY
 BLU : BLUE RED : RED
 BRN : BROWN WHT : WHITE
 GRN : GREEN YEL : YELLOW

SERVICE OPERATION

COLLECT REFRIGERANT FROM INDOOR UNIT AND STORE AT OUTDOOR UNIT.

- SWITCH OFF THE MAIN POWER SUPPLY AND THEN SWITCH IT ON AGAIN. WAIT FOR 1 MINUTE.
- PRESS AND HOLD THE SERVICE SWITCH FOR 1 SECOND TO START OUTDOOR UNIT IN COOLING OPERATION. IN ORDER TO PREVENT PARTS FROM DAMAGE, DO NOT OPERATE THE OUTDOOR UNIT FOR MORE THAN 5 MINUTES.
- PRESS AND HOLD THE SERVICE SWITCH FOR 1 SECOND TO STOP THE SERVICE OPERATION.
- REPEAT STEP 1 TO 3 IF SERVICE OPERATION NEED TO BE REPEATED.

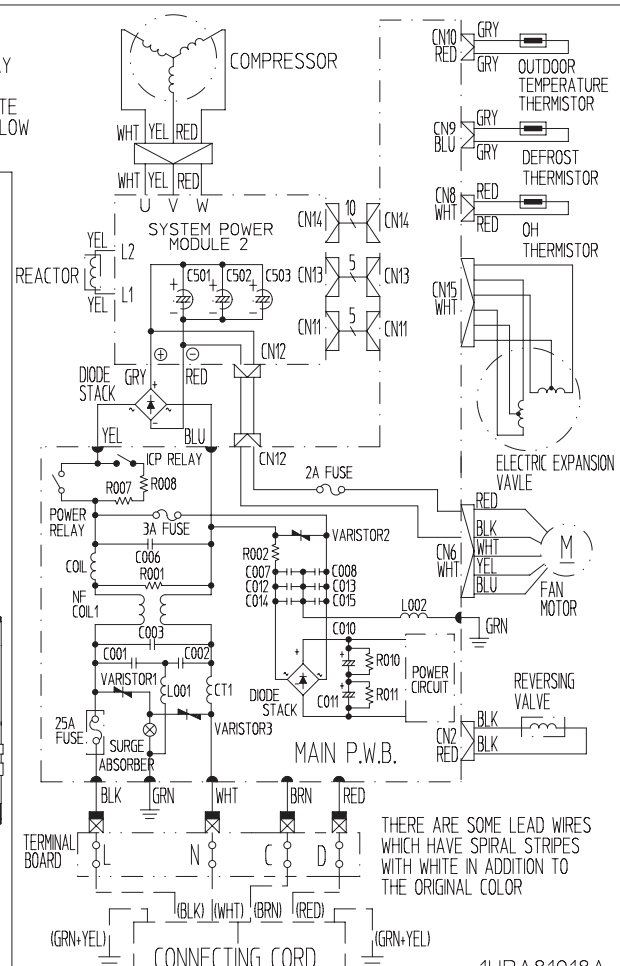

MEASURING POSITION OF DC VOLTAGE (P1) '+ve'.

MEASURING POSITION OF DC VOLTAGE (N1) '-ve'.

COMPONENTS: REACTOR, SYSTEM POWER MODULE 2, DIODE STACK, ICP RELAY, POWER RELAY, COIL, NF COIL 1, COIL 1, VARISTOR1, VARISTOR2, VARISTOR3, DIODE STACK, POWER CIRCUIT, REVERSING VALVE, FAN MOTOR, ELECTRIC EXPANSION VALVE, OH THERMISTOR, DEFROST THERMISTOR, OUTDOOR TEMPERATURE THERMISTOR.

TERMINAL BOARD: (GRN+YEL), (BLK), (WHT), (BRN), (RED), (GRN+YEL)

CONNECTING CORD

1HRA81018A

CHECKING INDOOR UNIT ELECTRICAL PARTS

1. Power does not come on (no operation)

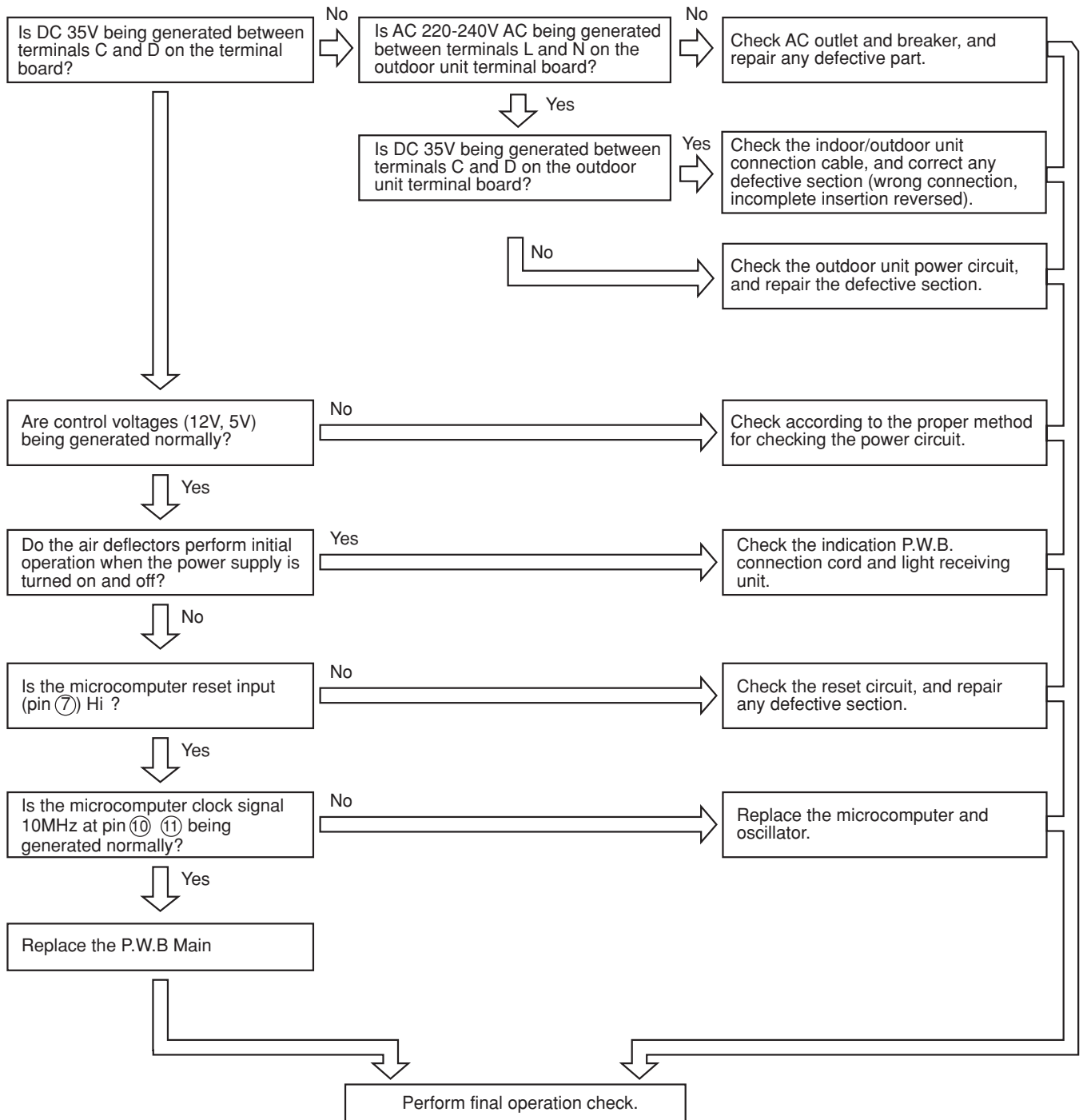

2. Outdoor unit does not operate (but receives remote infrared signal)

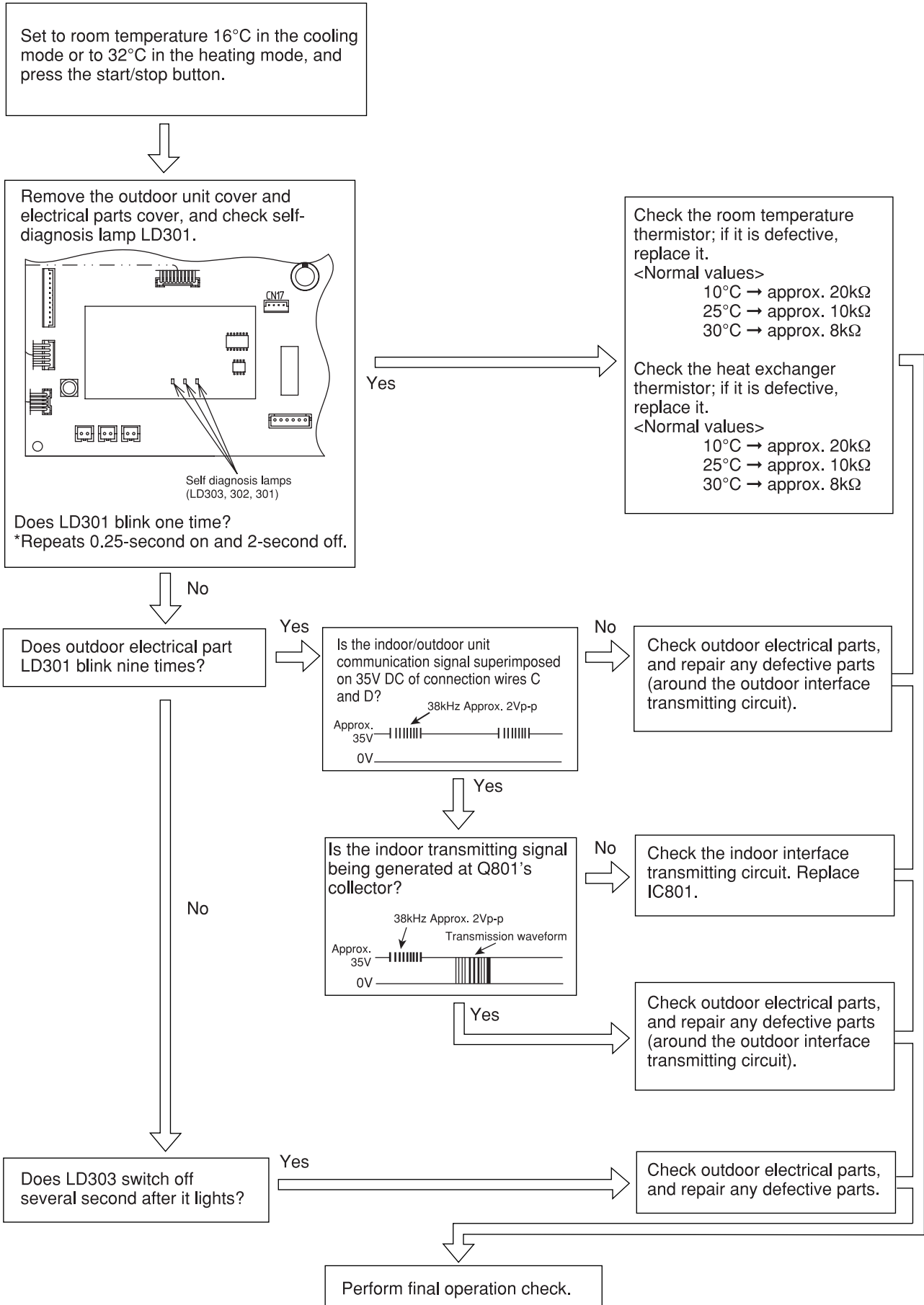

3. Only indoor fan does not operate (other is normal)

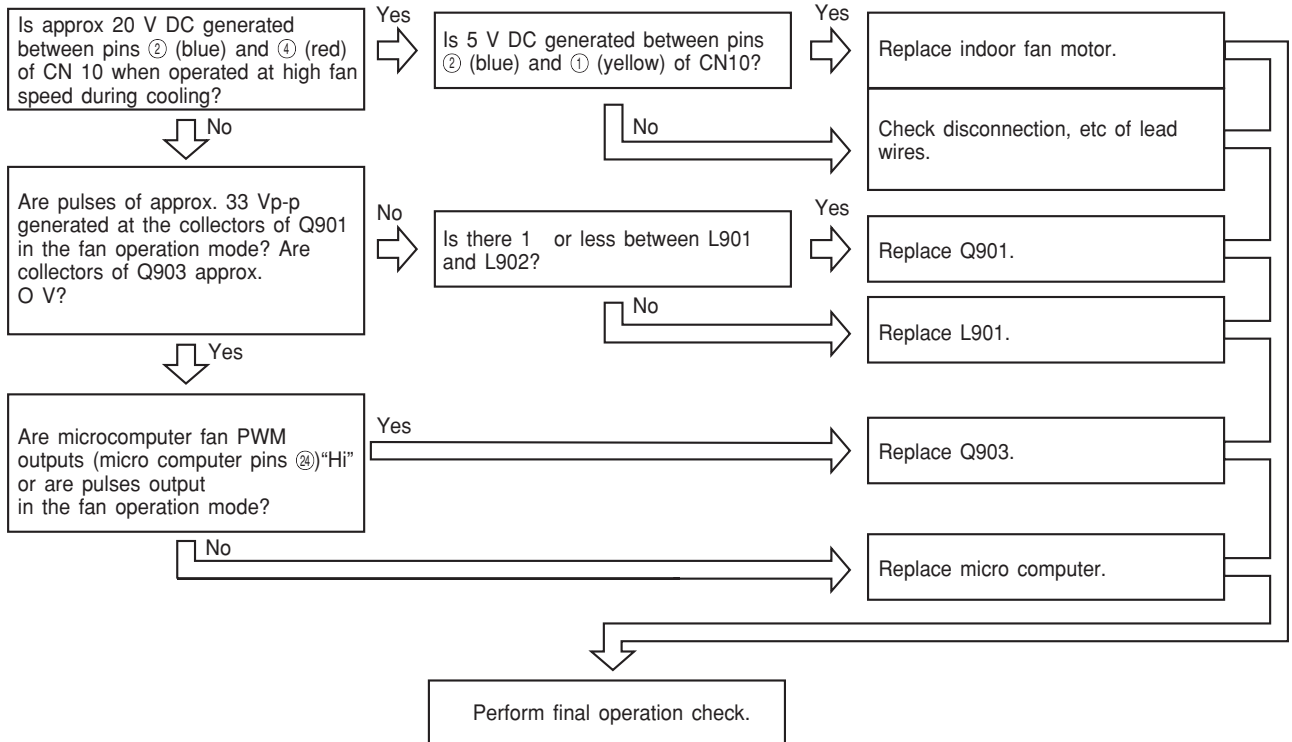

4. Indoor fan speed does not change (other is normal)

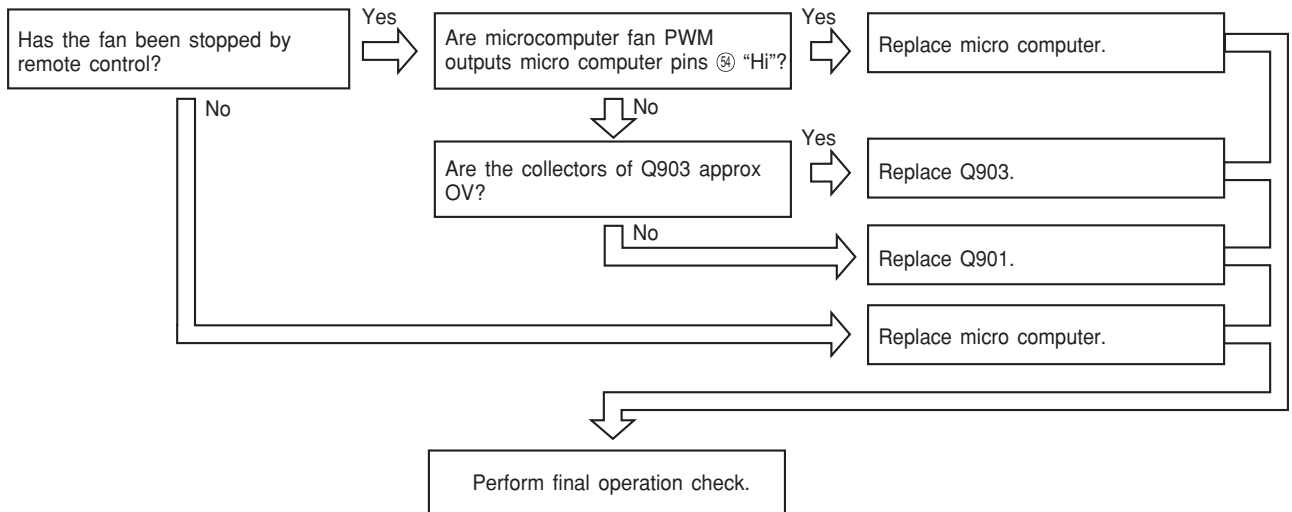

5. Air deflector does not move (other is normal)

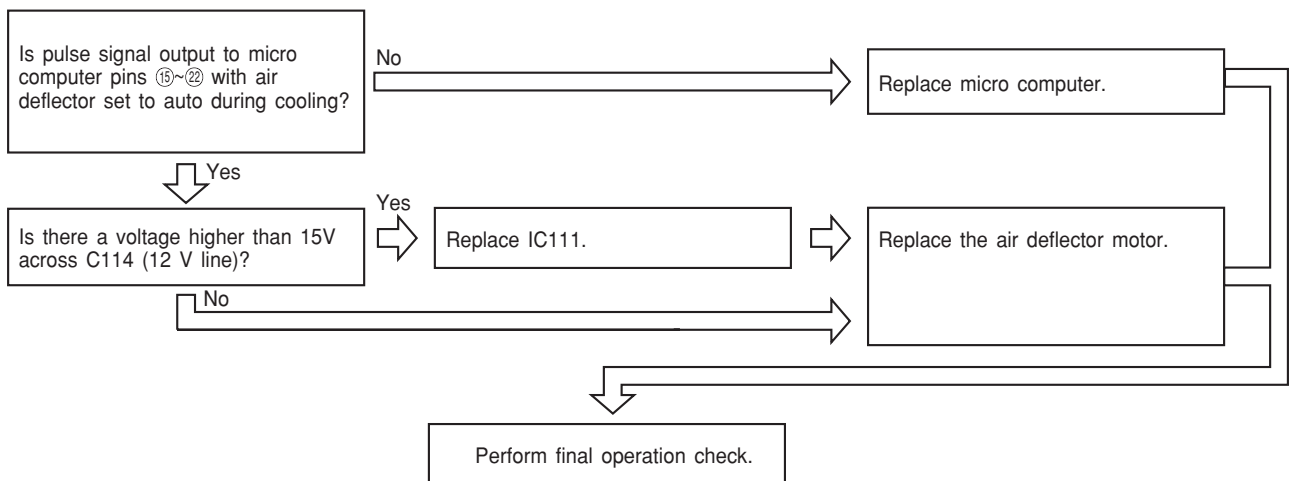

**6. All systems stop from several seconds to several minutes after operation is started
(all indicators are also off)**

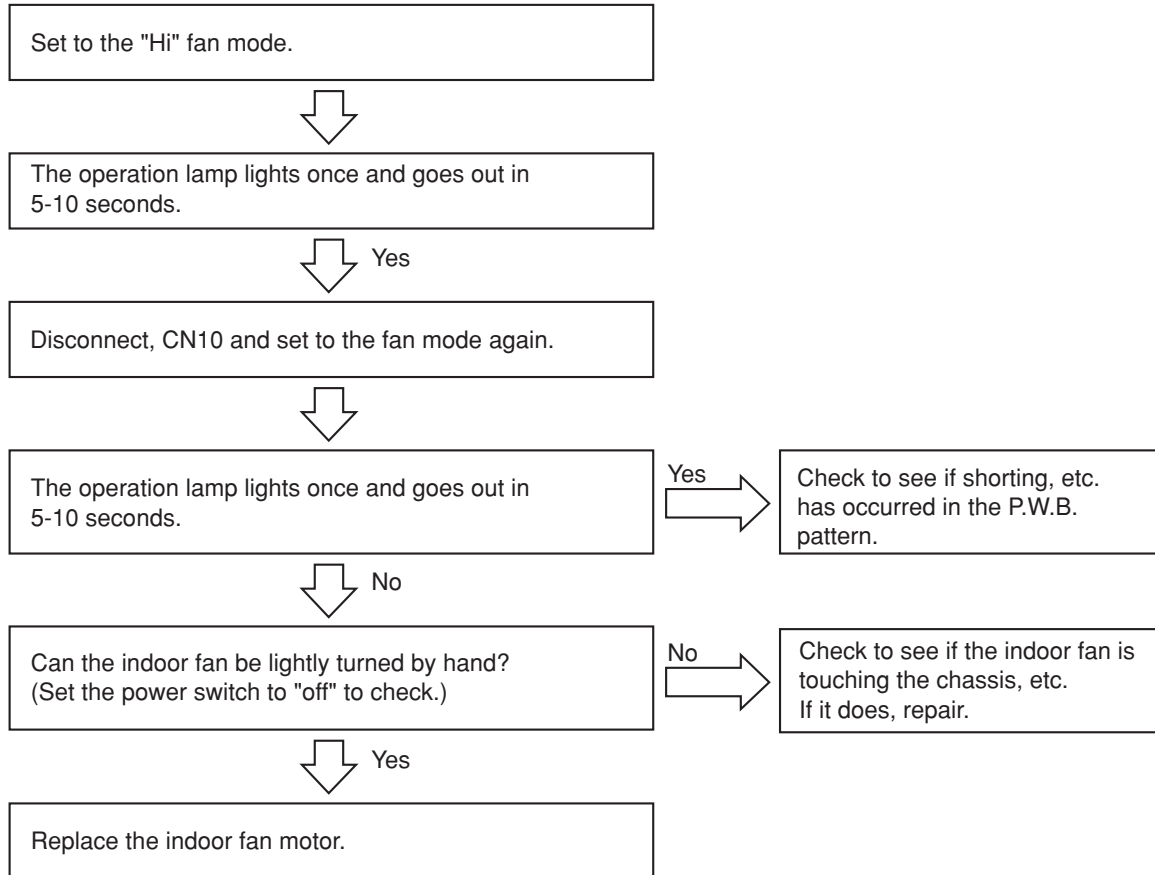

CHECKING THE REMOTE CONTROLLER

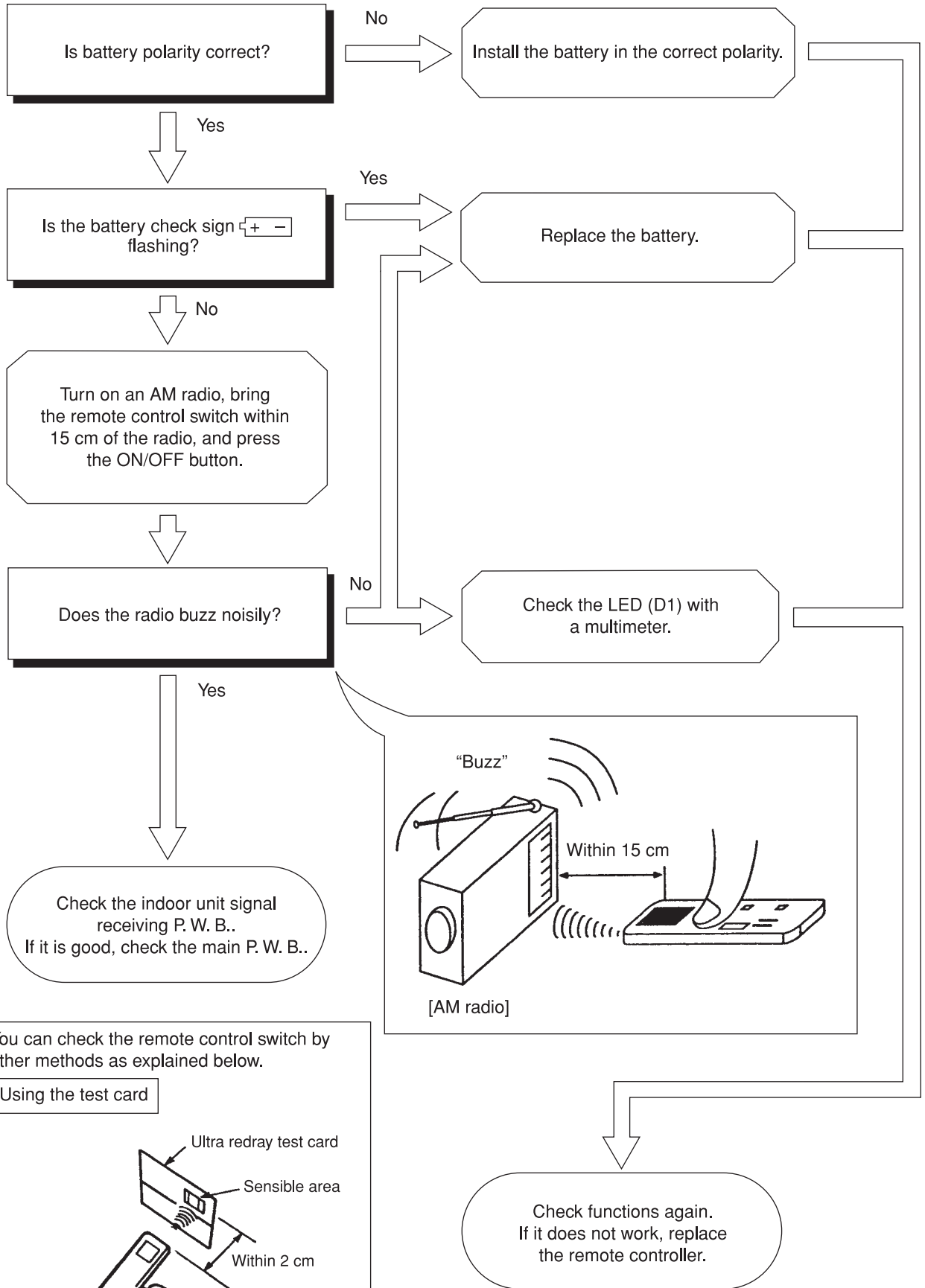

You can check the remote control switch by other methods as explained below.

Using the test card

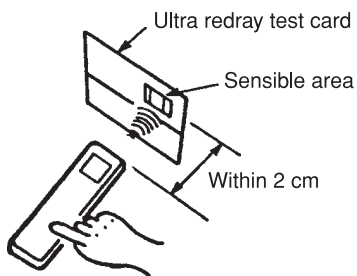

The sensible area should flash in orange when you operate the remote control unit if it is good.

CHECKING THE OUTDOOR UNIT ELECTRICAL PARTS

MODEL RAI-25NH4, RAI-40NH4

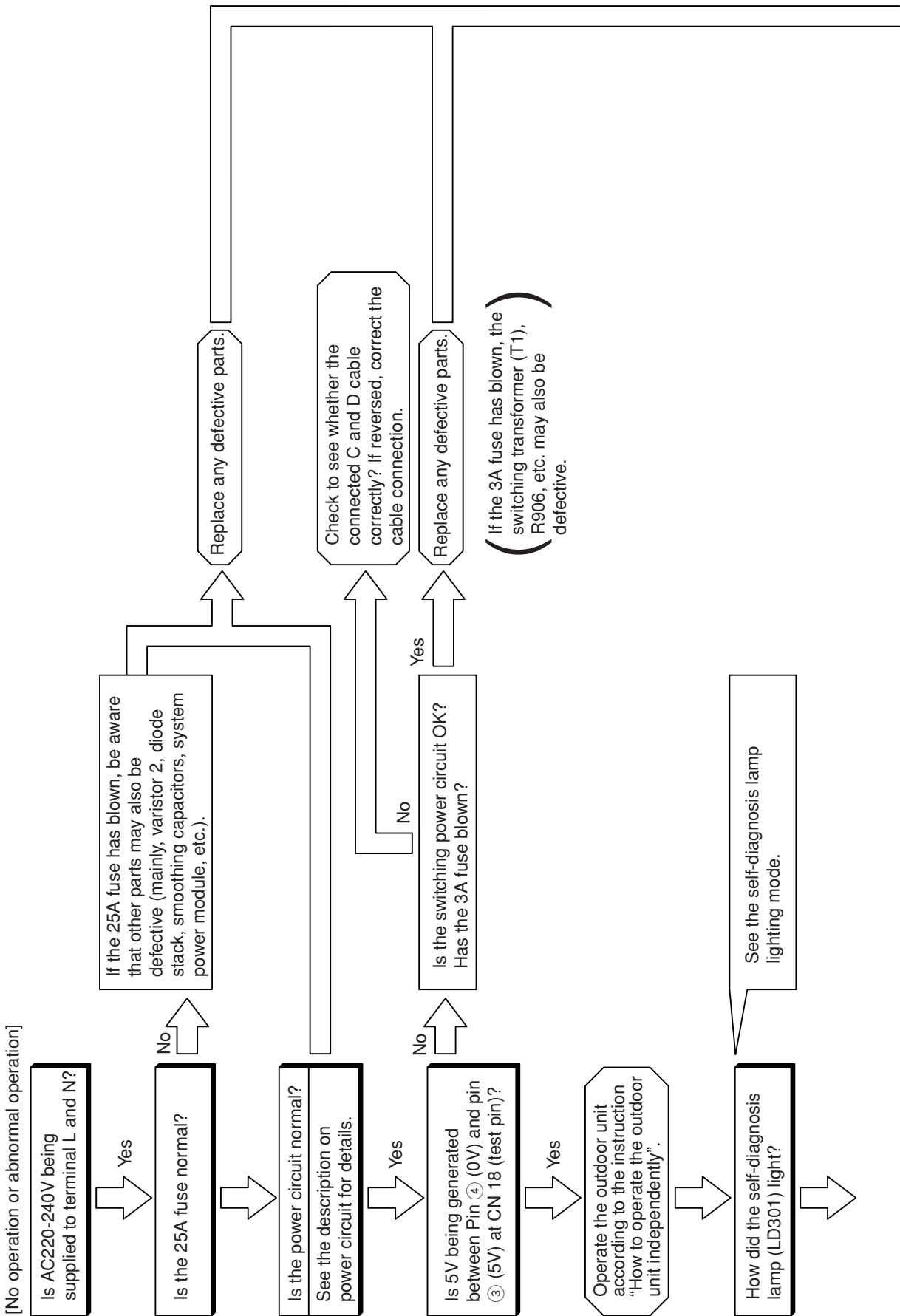

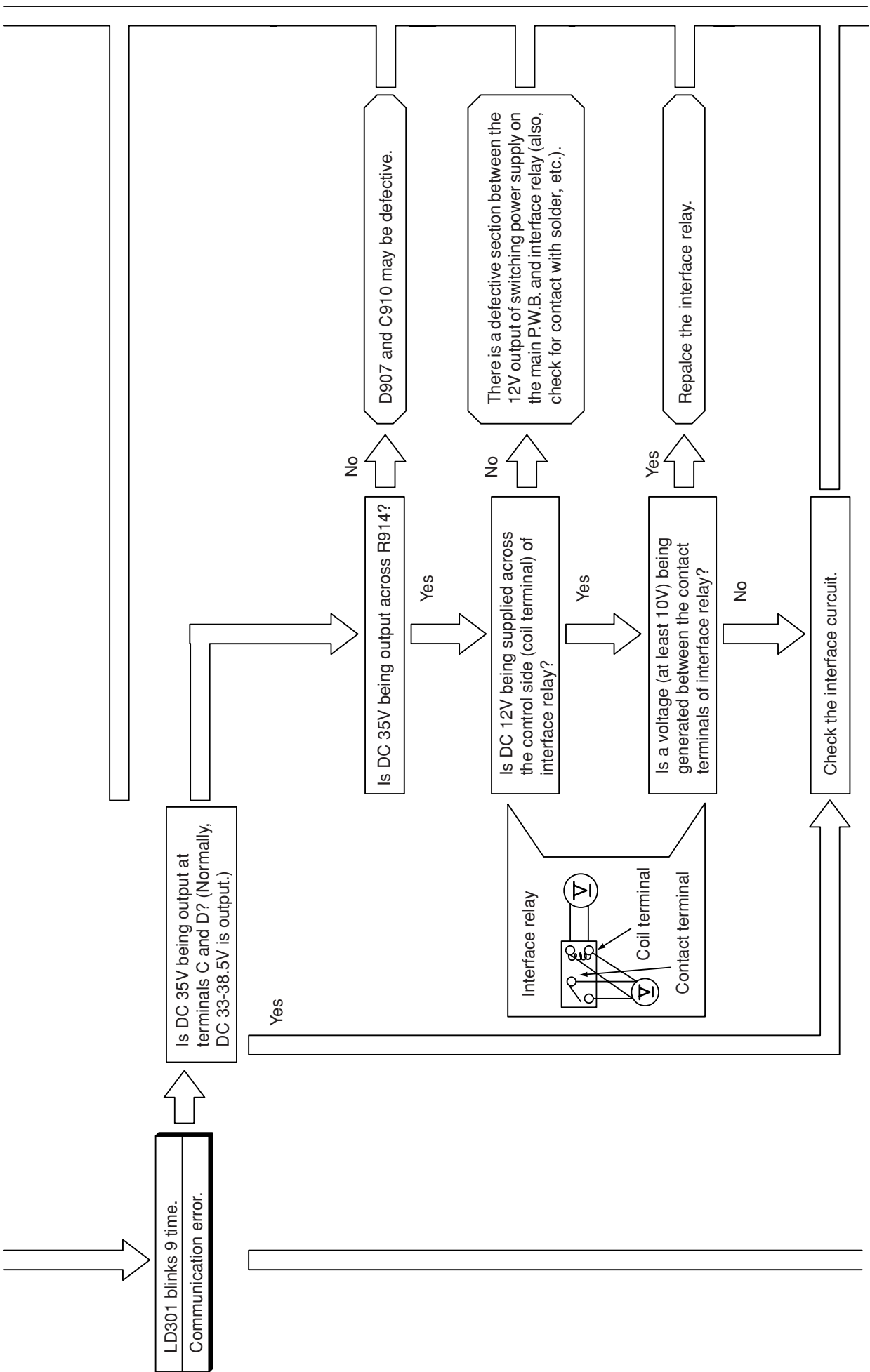

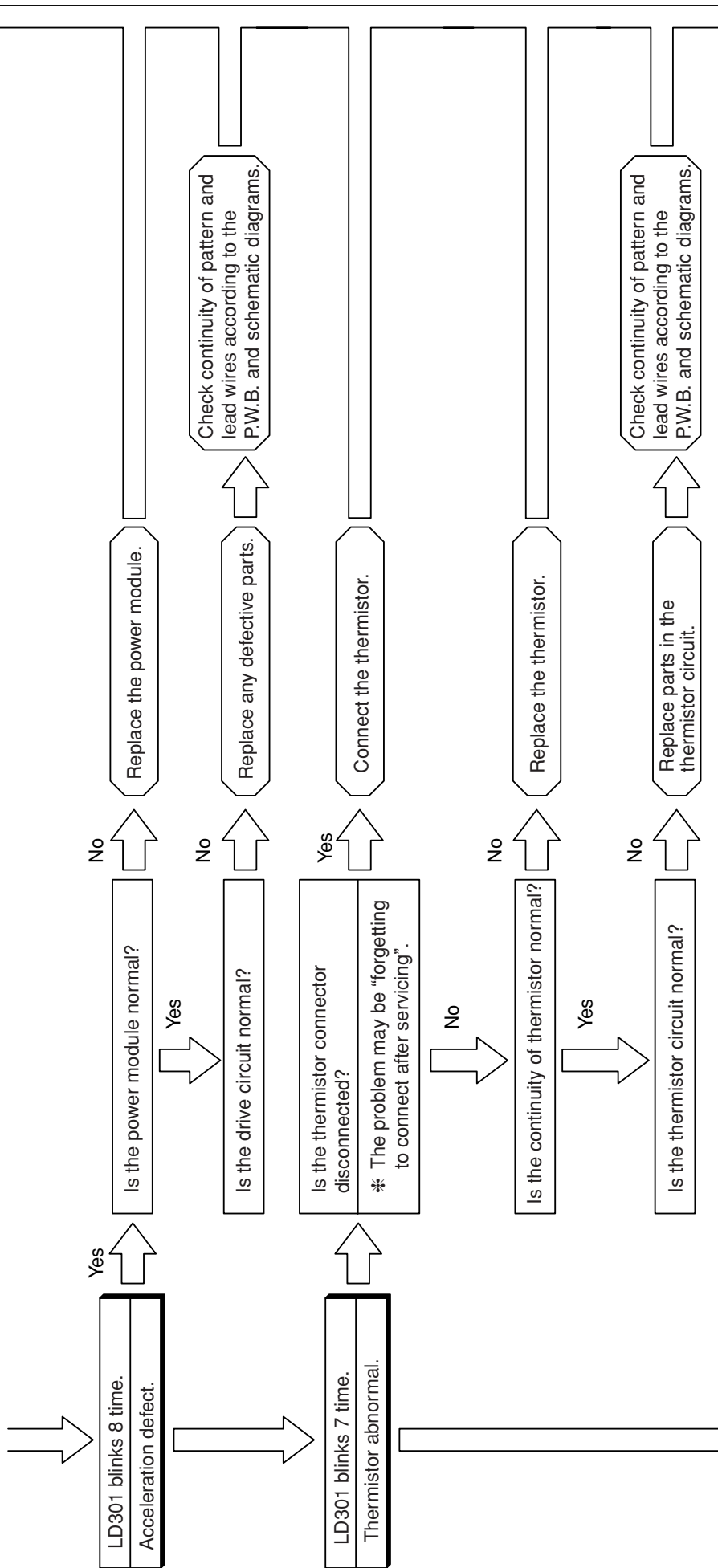

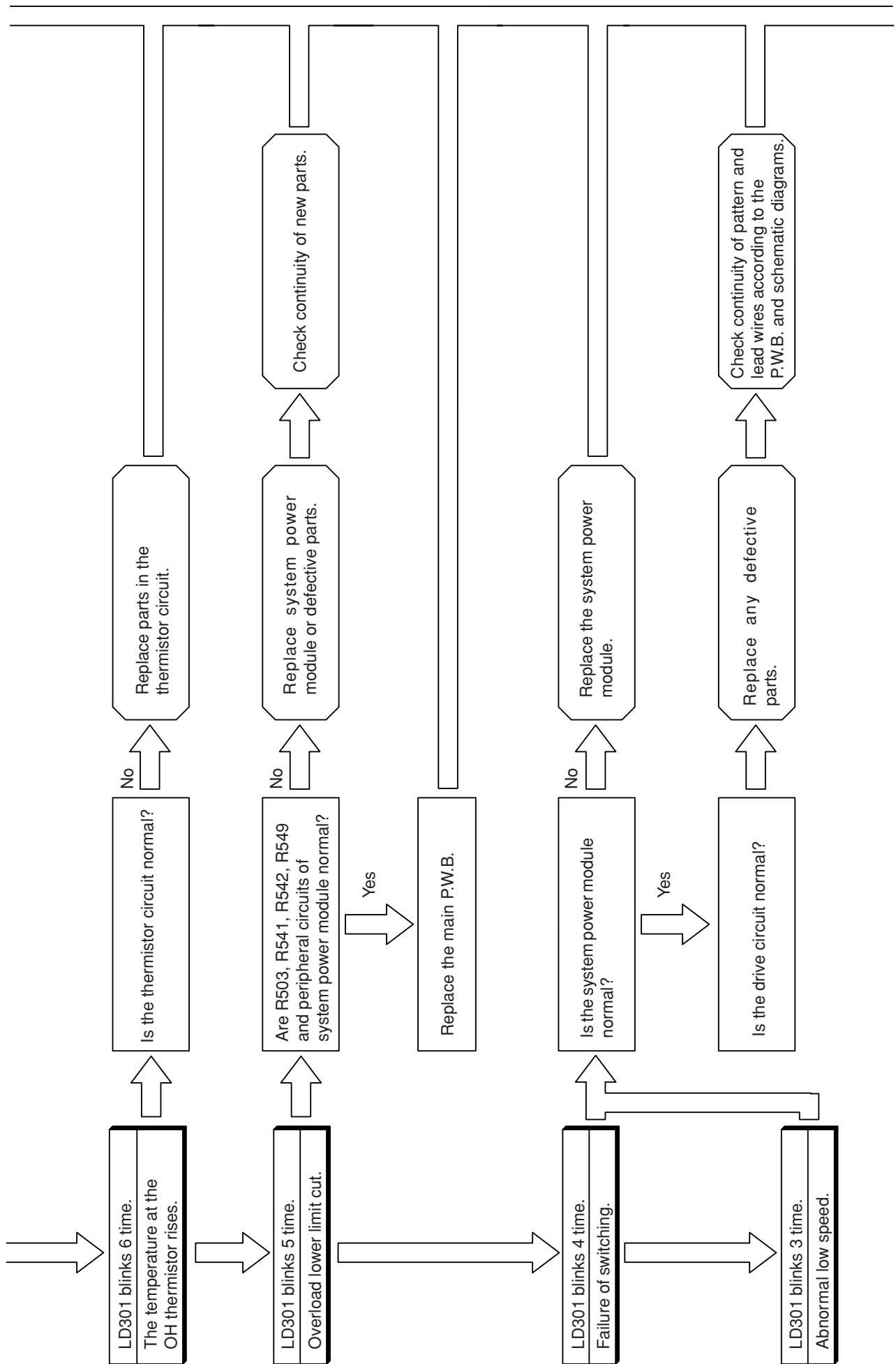

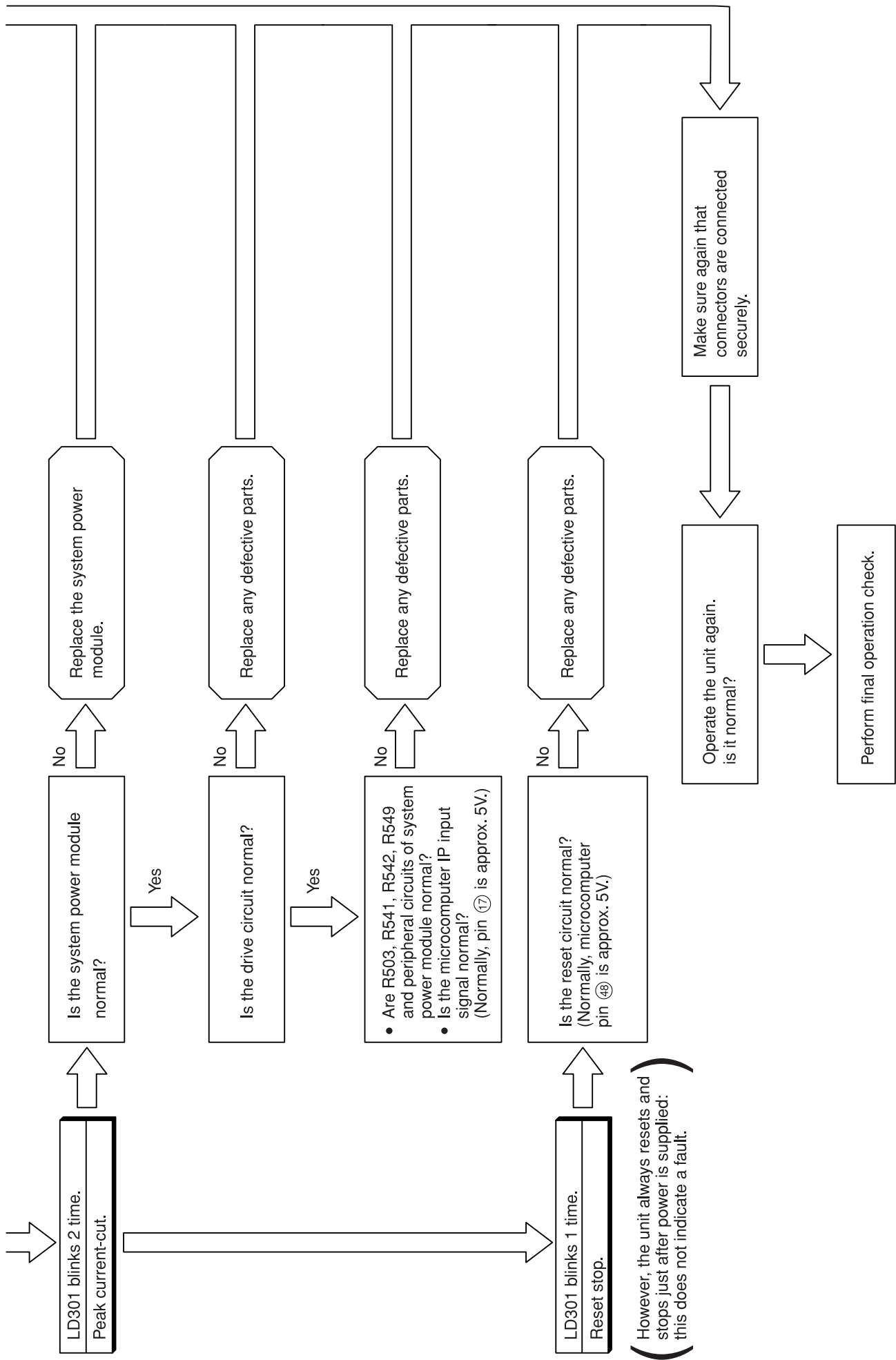

POWER CIRCUIT

Phenomenon 1 <Rotation speed does not increase>

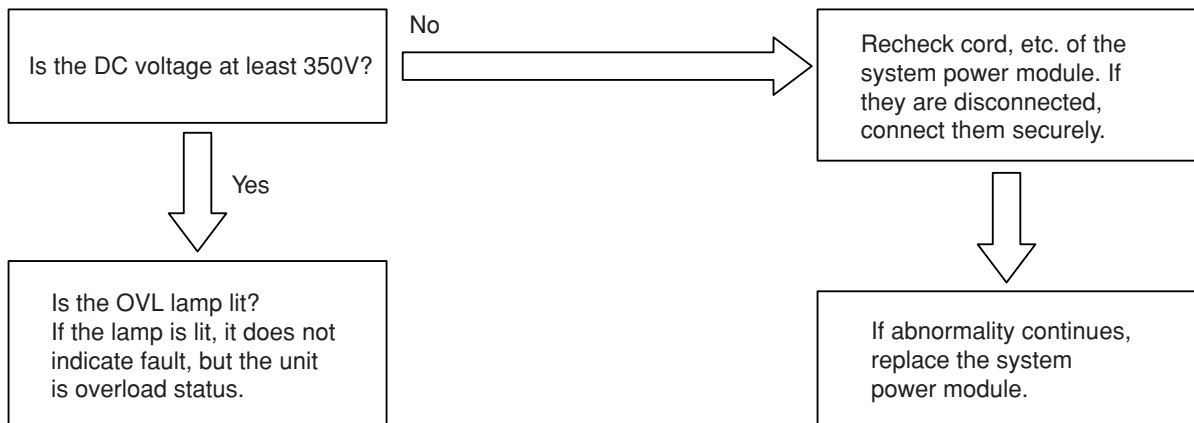

Overvoltage defect: system power module faulty (15-times blinking)

CHECKING THE REFRIGERATING CYCLE

(JUDGING BETWEEN GAS LEAKAGE AND COMPRESSOR DEFECTIVE)

1. Troubleshooting procedure (No operation, No heating, No cooling)

Connect U,V,W phase leads to the power module again and operate the air conditioner.

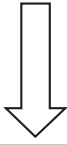

Is the self-diagnosis lamp mode as shown on the right?

Lighting mode Self-diagnosis lamp	Blinks 2 times	Blinks 3 times	Blinks 4 times	Blinks 5 times	Blinks 6 times	Blinks 8 times
LD301						
Time until the lamp lights	Approx. 10 seconds			Approx. 10 seconds	Within Approx. 30 seconds	Approx. 10 seconds
Possible malfunctioning part	Compressor				Gas leakage	Compressor

Blinking off

YES

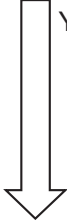

Stop to operate and check the gas pressure in balancing mode.

Normal
(0.39-0.98 MPaG)
(4-10 kg/cm²G)

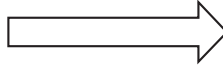

● Checking the system power module

Gas leaking
(less than 4kg/cm²G)
(less than 0.39 MPaG)



Gas leaks.
Repair and seal refrigerant.

When the self-diagnosis lamp lights in the same condition as above.



The compressor is defective. Replace it and seal refrigerant.
(If the compressor checker for an inverter type air conditioner is available, re-check using it.)

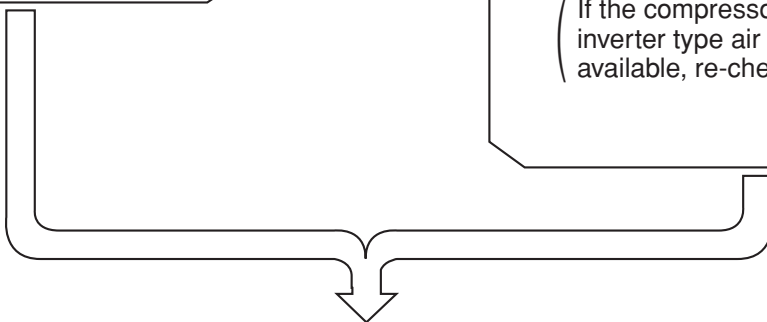

Perform a final check of operation.

HOW TO CHECK SYSTEM POWER MODULE

Checking system power module using tester

Set tester to resistance range (X 100)

If indicator does not swing in the following conductivity check, the system power module is normal.

(In case of digital tester, since built-in battery is set in reverse direction, ⊕ and ⊖ terminals are reversed.)



If inner circuit of system power module is disconnected (open), the indicator of tester will not swing and this may assumed as normal. In this case, if indicator swings when ⊕ and ⊖ terminals are connected in reverse of diagram below, it is normal. Furthermore, compare how indicator swings at U, V and W phases. If indicator swings the same way at each point, it is normal.

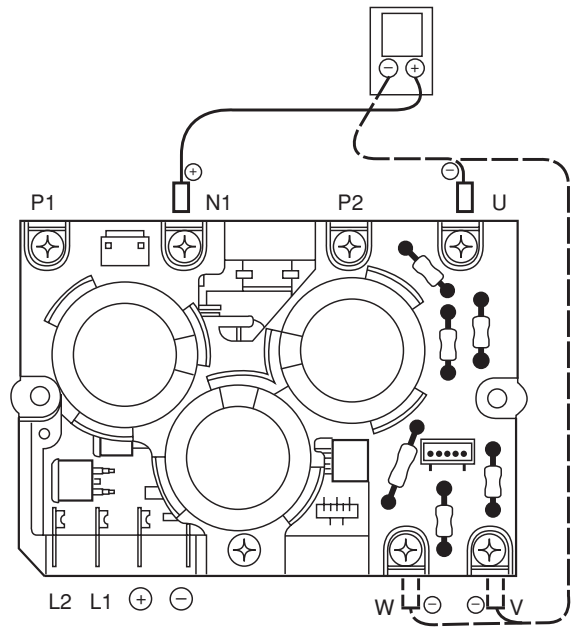
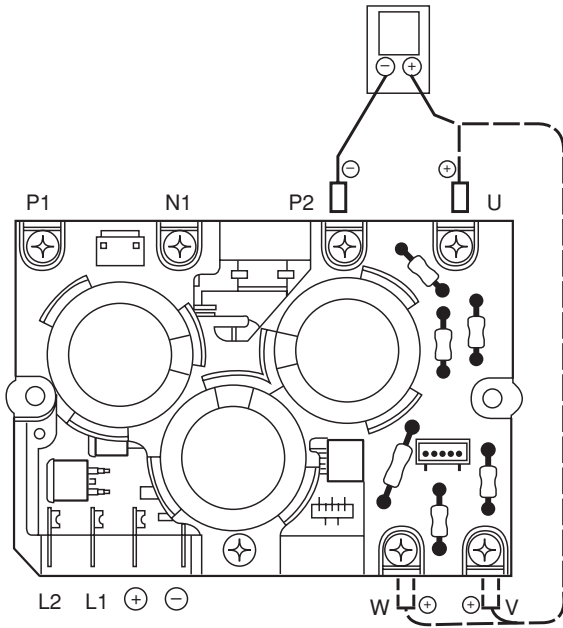

HOW TO OPERATE USING THE SERVICE SWITCH THE OUTDOOR UNIT

MODEL RAI-25NH4, RAI-40NH4

1. Turn off the power supply to outdoor unit and then turn on again.
2. Remove the electrical box cover.

LD303 (red) will light and the unit will operate in the forced cooling mode at this time.

Never operate the unit for more than 5 minutes.

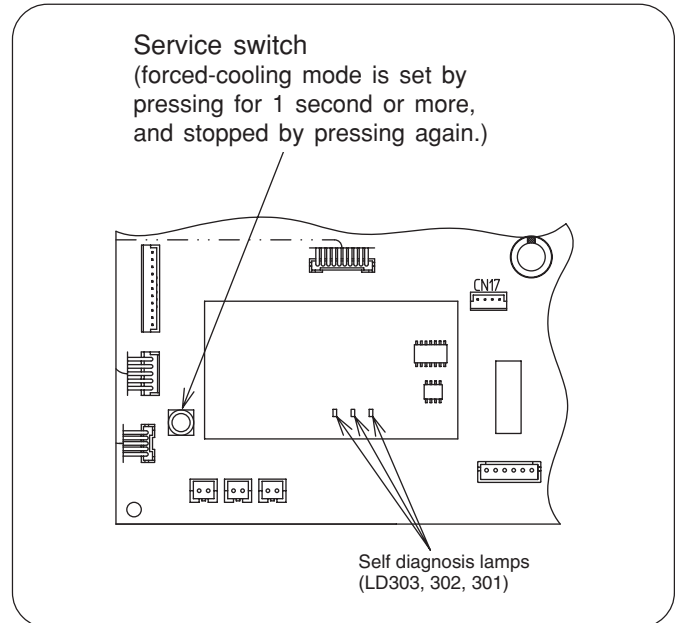
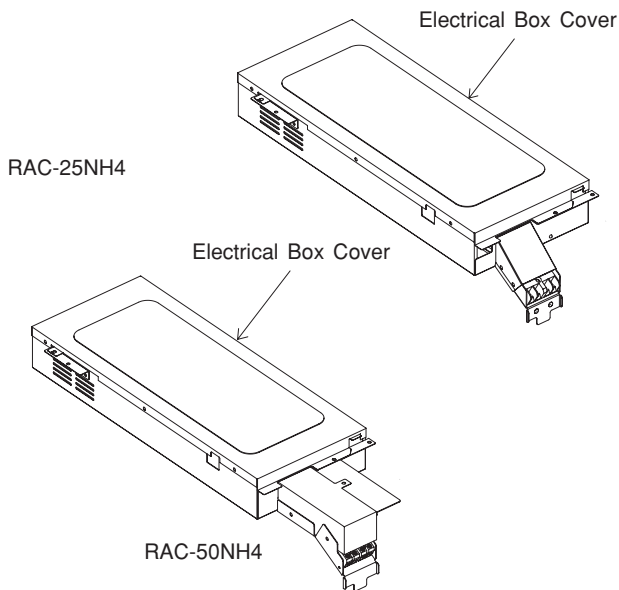

(Cautions)

- (1) If interface signal (DC 35V) terminals C and D are not connected when the outdoor unit is in forced cool mode, the outdoor unit defect indicator (LD301) will blink 9 times during operation to indicate communication error.
- (2) If checking is done with the compressor connector disconnected, the unit will continue normal operation when the electrical parts are normal, or it will repeat operating for approx. one minute and stop due to overload power limit cut, or it will operate in the overload status.

Be sure to push the service switch again to stop the forced cool operation.

HOW TO OPERATE THE OUTDOOR UNIT INDEPENDENTLY

1. Connect the large dia. pipe side and small dia. pipe side service valves using a pipe.

Connect the small diameter service valve and the large diameter service valve using the reducing union and copper pipe as shown on the right.

Charge refrigerant of 300g after vacuuming (※ 1)

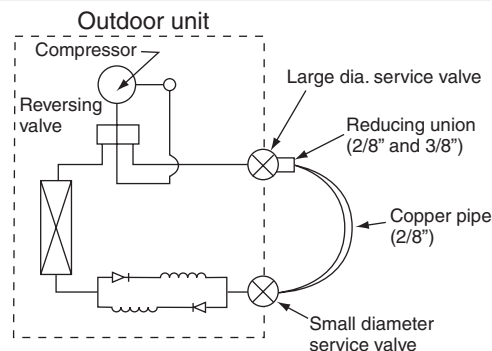

Parts to be prepared

- (1) Reducing union
2/8" (6.35mm)
1/2" (12.7mm)
- (2) Copper pipe (2/8" and 1/2")
- (3) Shorting leads
2 leads approx. 10 cm long with alligator clip or IC clip

Do not operate for more than 5 minutes

The operation method is the same as "How to operate using the connector to servicing the outdoor unit".

※ 1 The charging amount of 300g is equivalent to the load in normal operation.

SYSTEM POWER MODULE DIAGNOSIS

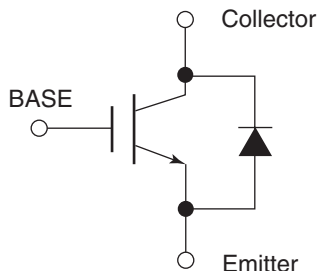
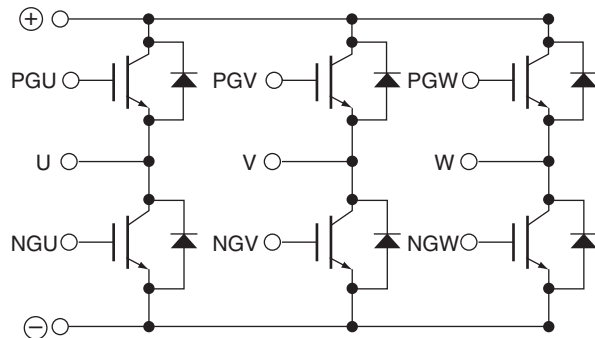
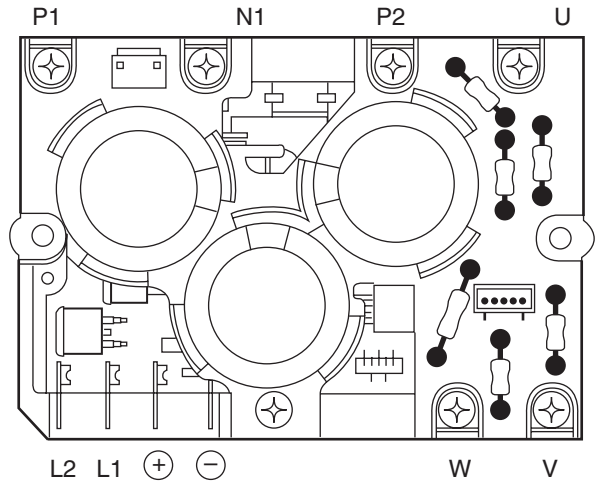
<p>Circuit diagram of the device (excepting the reflux diode)</p>	
<p>Circuit diagram of the module</p>	
<p>Terminals symbol mark of the module</p> <p>※ See next page for measuring value using tester</p>	

PARTS LIST AND DIAGRAM

MODEL RAI-ECPM

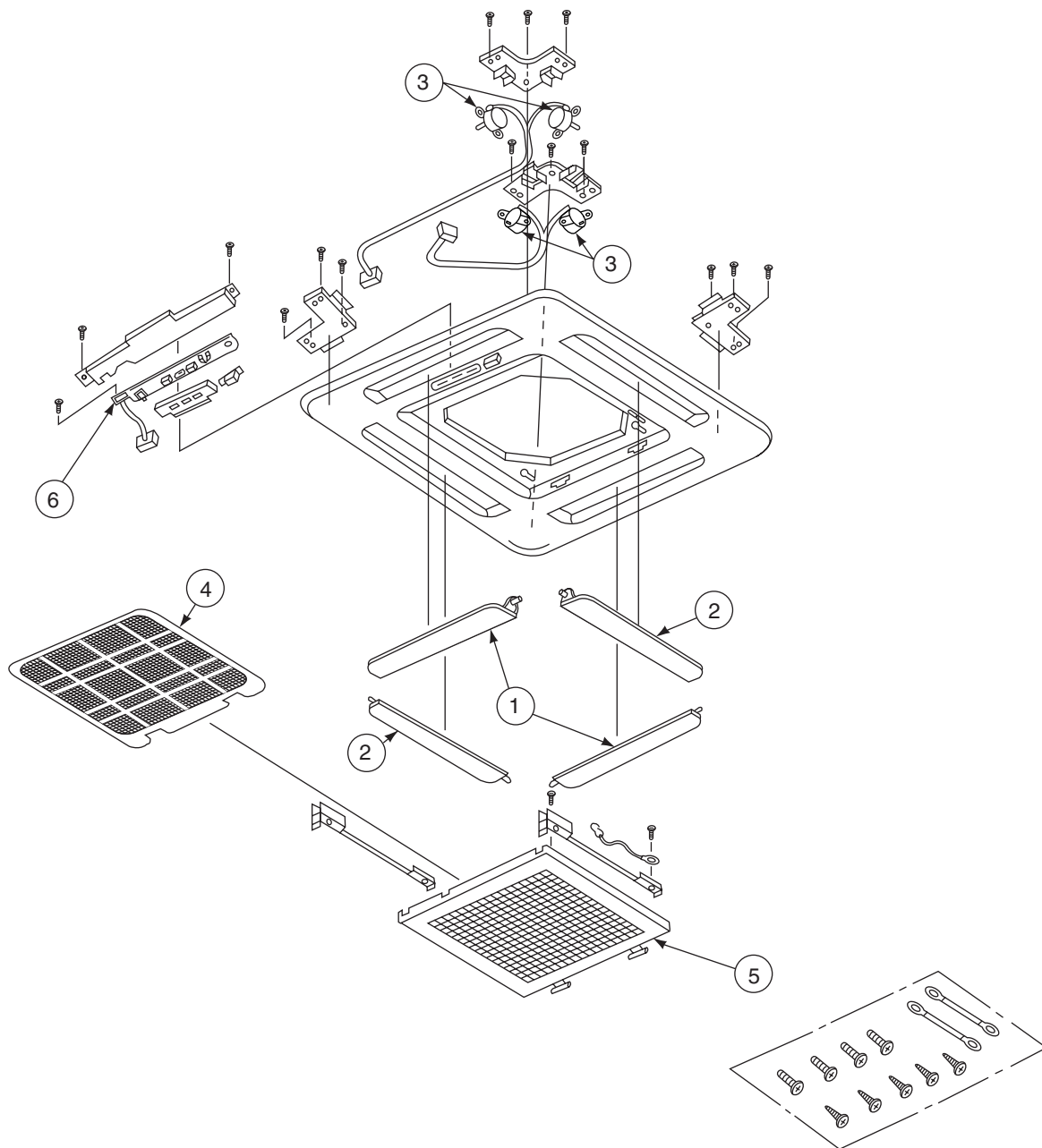

MODEL RAI-ECPM

NO.	PART NO. RAI-ECPM	Q'TY / UNIT	PARTS NAME
1	PMRAI-ECPM 001	2	HORIZONTAL AIR DEFLECTOR 1
2	PMRAI-ECPM 002	2	HORIZONTAL AIR DEFLECTOR 2
3	PMRAI-ECPM 003	4	STEP MOTOR
4	PMRAI-ECPL 004	1	FILTER
5	PMRAI-ECPM 004	1	SUCTION GRILL
6	PMRAI-ECPM 005	1	P.W.B. (DISPLAY)

PARTS LIST AND DIAGRAM

INDOOR UNIT

MODEL : RAI-25NH4, RAI-40NH4

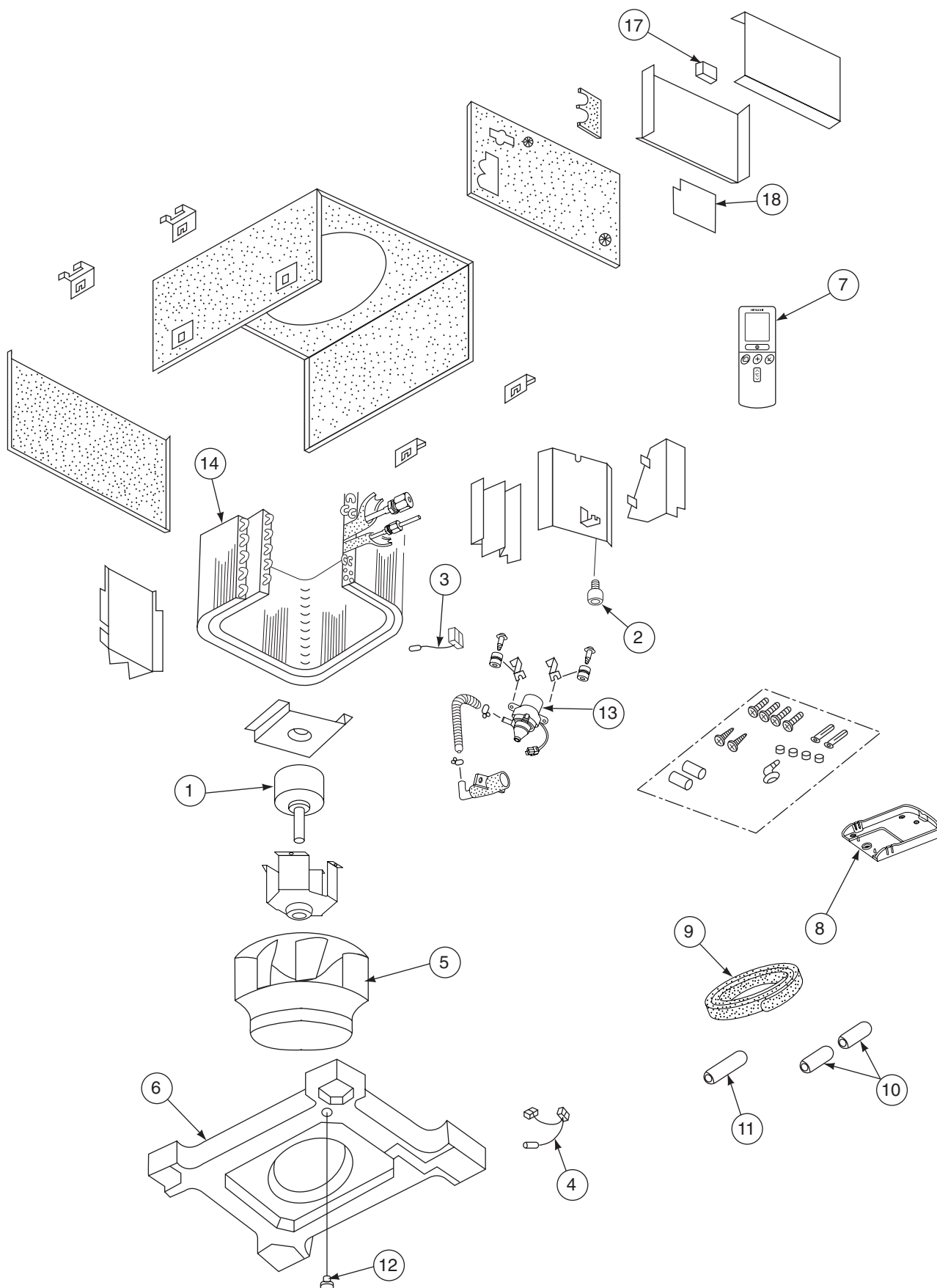

OUTDOOR UNIT
MODEL : RAC-25NH4, RAC-50NH4

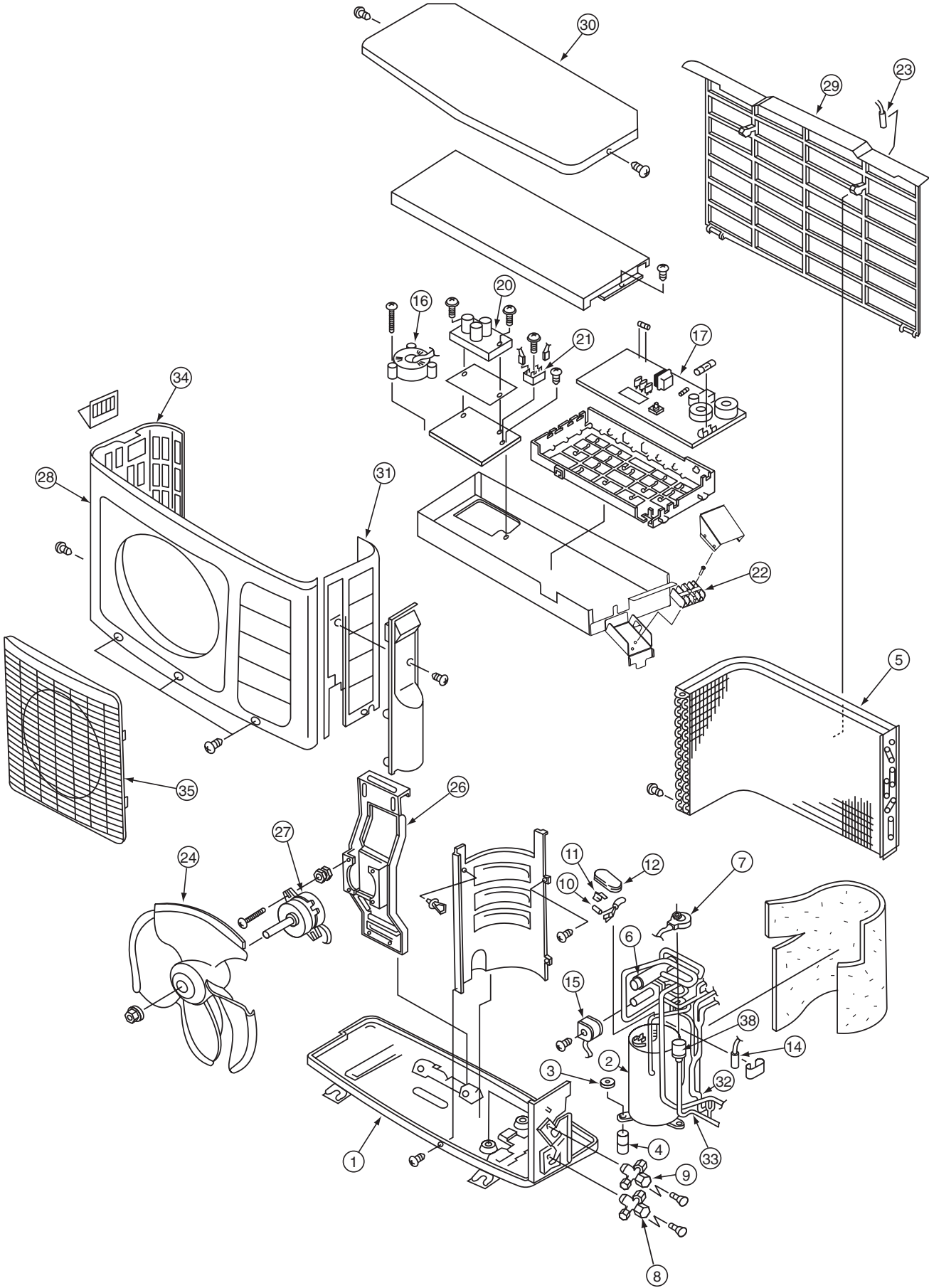

MODEL RAC-25NH4

NO.	PART NO. RAC-25NH4	Q'TY / UNIT	PARTS NAME
1	PMRAC-25NH4 918	1	BASE
2	PMRAC-25NH4 908	1	COMPRESSOR
3	KPNT1 001	6	PUSH NUT
4	RAC-2226HV 805	3	COMPRESSOR RUBBER
5	PMRAC-25NH4 901	1	CONDENSER
6	PMRAC-25NH4 902	1	REVERSING VALVE
7	PMRAC-25NH4 903	1	ELECTRICAL EXPANSION COIL
8	PMRAC-25NH4 904	1	VALVE (2S)
9	PMRAC-25NH4 905	1	VALVE (4S)
10	PMRAC-40CNH2 914	1	THERMISTOR (OH)
11	PMRAC-25NH4 909	1	OVERHEAT THERMISTOR SUPPORT
12	PMRAC-25NH4 910	1	OVERLOAD RELAY COVER
14	PMRAC-40CNH2 915	1	THERMISTOR (DEFROST)
15	PMRAC-07CHV1 921	1	COIL (REVERSING VALVE)
16	PMRAC-40CNH2 908	1	REACTOR
17	PMRAC-25NH4 906	1	P.W.B (MAIN)
20	PMRAC-25NH4 912	1	SYSTEM POWER MODULE
21	PMRAC-40CNH2 902	1	DIODE STACK (D25VB60)
22	PMRAC-25NH4 913	1	TERMINAL BOARD (4P)
23	PMRAC-40CNH2 916	1	THERMISTOR (OUTSIDE TEMPERATURE)
24	PMRAC-25CNH2 902	1	PROPELLER FAN
26	PMRAC-25NH4 914	1	SUPPORT (FAN MOTOR)
27	PMRAC-40CNH2 919	1	FAN MOTOR (40W)
28	PMRAC-51CA1 901	1	CABINET
29	PMRAC-51CA1 908	1	NET
30	PMRAC-51CA1 909	1	TOP COVER
31	PMRAC-25NH4 917	1	SIDE PLATE-R
32	PMRAC-25NH4 915	1	STRAINER
33	PMRAC-25NH4 907	1	STRAINER
35	PMRAC-09CHA1 903	1	GRILL
38	PMRAC-25NH4 916	1	EXPANSION VALVE

MODEL RAC-50NH4

NO.	PART NO. RAC-50NH4	Q'TY / UNIT	PARTS NAME
1	PMRAC-50NH4 901	1	BASE
2	PMRAC-50NH4 907	1	COMPRESSOR
3	KPNT1 001	4	PUSH NUT
4	RAC-2226HV 805	3	COMPRESSOR RUBBER
5	PMRAC-50NH4 902	1	CONDENSER
6	PMRAC-25NH4 902	1	REVERSING VALVE
7	PMRAC-25NH4 903	1	ELECTRICAL EXPANSION COIL
8	PMRAC-50NH4 903	1	VALVE (2S)
9	PMRAC-50NH4 904	1	VALVE (4S)
10	PMRAC-40CNH2 914	1	THERMISTOR (OH)
11	PMRAC-25NH4 909	1	OVERHEAT THERMISTOR SUPPORT
12	PMRAC-25NH4 910	1	OVERLOAD RELAY COVER
14	PMRAC-40CNH2 915	1	THERMISTOR (DEFROST)
15	PMRAC-07CHV1 921	1	COIL (REVERSING VALVE)
16	PMRAC-40CNH2 908	1	REACTOR
17	PMRAC-50NH4 905	1	P.W.B (MAIN)
20	PMRAC-40CNH2 901	1	SYSTEM POWER MODULE
21	PMRAC-40CNH2 902	1	DIODE STACK (D25VB60)
22	PMRAS-10C6M 002	2	TERMINAL BOARD (2P)
23	PMRAC-40CNH2 916	1	THERMISTOR (OUTSIDE TEMPERATURE)
24	PMRAC-40CNH2 917	1	PROPELLER FAN
26	PMRAC-40CNH2 918	1	SUPPORT (FAN MOTOR)
27	PMRAC-40CNH2 919	1	FAN MOTOR (40W)
28	PMRAC-40CNH2 904	1	CABINET
29	PMRAC-40CNH2 921	1	NET
30	PMRAC-40CNH2 922	1	TOP COVER
31	PMRAC-50NH4 910	1	SIDE PLATE-R
32	PMRAC-50NH4 906	1	STRAINER
33	PMRAC-50NH4 909	1	STRAINER
34	PMRAC-40CNH2 926	1	SIDE PLATE-L
35	PMRAC-40CNH2 928	1	GRILL
38	PMRAC-25NH4 916	1	EXPANSION VALVE

HITACHI

RAI-25NH4
RAI-40NH4

PM NO. 0212E

Printed in Malaysia