

Service Manual

Monobloc Air-to-Water Heatpump System

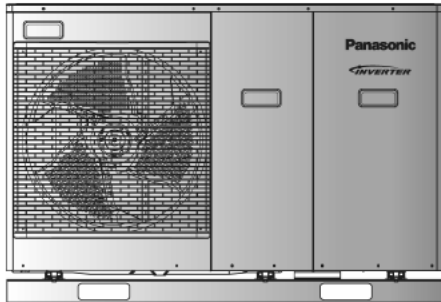

Monobloc Unit
WH-MDF06D3E5
WH-MDF09D3E5

WARNING

This service information is designed for experienced repair technicians only and is not designed for use by the general public. It does not contain warnings or cautions to advise non-technical individuals of potential dangers in attempting to service a product. Products powered by electricity should be serviced or repaired only by experienced professional technicians. Any attempt to service or repair the product or products dealt with in this service information by anyone else could result in serious injury or death.

PRECAUTION OF LOW TEMPERATURE

In order to avoid frostbite, be assured of no refrigerant leakage during the installation or repairing of refrigerant circuit.

Panasonic[®]



© Panasonic HA Air-Conditioning (M) Sdn. Bhd. 2011.
Unauthorized copying and distribution is a violation of law.

TABLE OF CONTENTS

	PAGE		PAGE
1. Safety Precautions	3	15. Maintenance Guide.....	54
2. Specifications	5	16. Troubleshooting Guide.....	56
2.1 WH-MDF06D3E5.....	5	16.1 Refrigeration Cycle System	56
2.2 WH-MDF09D3E5.....	7	16.2 Relationship Between The Condition Of The Monobloc Unit And Pressure And Electric Current	57
3. Features.....	9	16.3 Breakdown Self Diagnosis Function	58
4. Location of Controls and Components.....	10	16.4 Error Codes Table.....	59
4.1 Monobloc Unit.....	10	16.5 Self-diagnosis Method	61
5. Dimensions	17	17. Disassembly and Assembly Instructions	94
5.1 Monobloc Unit.....	17	17.1 To Remove The Cabinet Front Plate	94
6. Refrigeration and Water Cycle Diagram	18	17.2 To Remove The Cabinet Top Plate	94
7. Block Diagram	20	17.3 To Remove The Cabinet Rear Plate.....	95
8. Wiring Connection Diagram	21	17.4 To Remove Pressure Gauge	95
9. Electronic Circuit Diagram	23	17.5 To Remove RCCB	96
10. Printed Circuit Board	25	17.6 To Remove Transformer and Electronic Controller Board.....	96
10.1 Water System	25	17.7 To Remove Pressure Relief Valve.....	97
10.2 Refrigerant System	27	17.8 To Remove Flow Switch	97
11. Installation Instruction Monobloc Unit.....	29	17.9 To Remove Water Pump	97
11.1 Select the Best Location	31	18. Technical Data	98
11.2 Mono Bloc Unit Installation	31	18.1 Operation Characteristics	98
11.3 Piping Installation.....	32	18.2 Heating Capacity Table.....	100
11.4 Connect The Cord And Cable To Mono Bloc Unit.....	33	18.3 Hydraulic Pump Performance.....	100
12. Operation and Control	37	19. Exploded View and Replacement Parts List	101
12.1 Basic Function	37	19.1 WH-MDF06D3E5 WH-MDF09D3E5 (Refrigerant System).....	101
12.2 Water Pump	43	19.2 WH-MDF06D3E5 WH-MDF09D3E5 (Water System).....	105
12.3 Pump Down Operation	43		
12.4 Flow Switch.....	44		
12.5 Force Heater Mode Operation	44		
12.6 Monobloc Unit Safety.....	44		
12.7 Auto Restart Control	44		
12.8 Indication Panel	45		
12.9 Back-Up Heater Control.....	45		
12.10 Tank Booster Heater Control	46		
12.11 Three Way Valve Control.....	46		
12.12 Sterillization Mode.....	46		
12.13 Quiet Operation.....	46		
12.14 Solar operation (Optional).....	47		
12.15 External Room Thermostat Control (Optional)	50		
13. Protection Control.....	51		
13.1 Protection Control For All Operations	51		
13.2 Protection Control For Heating Operation	52		
14. Servicing Mode	53		
14.1 Test Run	53		
14.2 Proper Pump Down Procedure.....	53		
14.3 How To Adjust Water Flow Rate.....	53		
14.4 Expansion Vessel Pre Pressure Checking.....	53		

1. Safety Precautions



- Read the following “SAFETY PRECAUTIONS” carefully before perform any servicing.
- Electrical work and water installation work must be installed or serviced by a licensed electrician and licensed water system installer respectively. Be sure to use the correct rating and main circuit for the model installed.
- The caution items stated here must be followed because these important contents are related to safety. The meaning of each indication used is as below. Incorrect installation or servicing due to ignoring of the instruction will cause harm or damage, and the seriousness is classified by the following indications.

 WARNING	This indication shows the possibility of causing death or serious injury.
 CAUTION	This indication shows the possibility of causing injury or damage to properties.





- The items to be followed are classified by the symbols:

	This symbol denotes item that is PROHIBITED from doing.
---	---









- Carry out test run to confirm that no abnormality occurs after the servicing. Then, explain to user the operation, care and maintenance as stated in instructions. Please remind the customer to keep the operating instructions for future reference.

 WARNING	
1.	Do not modify the machine, part, material during repairing service.
2.	If wiring unit is supplied as repairing part, do not repair or connect the wire even only partial wire break. Exchange the whole wiring unit.
3.	Do not wrench the fasten terminal. Pull it out or insert it straightly.
4.	Engage dealer or specialist for installation and servicing. If installation of servicing done by the user is defective, it will cause water leakage, electrical shock or fire.
5.	Install according to this installation instructions strictly. If installation is defective, it will cause water leakage, electric shock or fire.
6.	Use the attached accessories parts and specified parts for installation and servicing. Otherwise, it will cause the set to fall, water leakage, refrigerant leakage, fire or electrical shock.
7.	Install at a flat horizontal, strong and firm location which is able to withstand the monobloc unit's weight. If the strength is not enough or installation is not properly done, the set will drop and cause injury.
8.	Do not install monobloc unit near handrail of veranda. When installing monobloc unit at veranda of high rise building, child may climb up to monobloc unit and cross over the handrail and causing accident. 
9.	For electrical work, follow the local national wiring standard, regulation and the installation instruction. An independent circuit and single outlet must be used. If electrical circuit capacity is not enough or defect found in electrical work, it will cause electrical shock or fire.
10.	This equipment must be properly earthed. Earth line must not be connected to gas pipe, water pipe, earth of lightning rod and telephone. Otherwise, it may cause electric shock in case equipment breakdown or insulation breakdown.
11.	Do not use joint cable for monobloc unit connection cable. Use specified monobloc unit connection cable, refer to Installation Instructions CONNECT THE CABLE TO THE MONOBLOC UNIT and connect tightly for monobloc unit connection. Clamp the cable so that no external force will be acted on the terminal. If connection or fixing is not perfect, it will cause heat up or fire at the connection.
12.	When install or relocate monobloc unit, do not let any substance other than the specified refrigerant, eg. air etc. mix into refrigerant cycle (piping). Mixing of air etc. will cause abnormal high pressure in refrigeration cycle and result in explosion, injury etc.
13.	This is a R410A model. When connecting the piping, do not use any existing (R22) pipes and flare nuts. Using such same may cause abnormally high pressure in the refrigeration cycle (piping), and possibly result in explosion and injury. Use only R410A refrigerant. Thickness of copper pipes used with R410A must be more than 0.8 mm. Never use copper pipes thinner than 0.8 mm. It is desirable that the amount of residual oil is less than 40 mg/10 m. 
14.	During installation, install the refrigerant piping properly before run the compressor. Operation of compressor without fixing refrigeration piping and valves at opened condition will cause suck-in of air, abnormal high pressure in refrigeration cycle and result in explosion, injury etc.
15.	During pump down operation, stop the compressor before remove the refrigeration piping. Removal of refrigeration piping while compressor is operating and valves are opened condition will cause suck-in of air, abnormal high pressure in refrigeration cycle and result in explosion, injury etc.
16.	After completion of the installation servicing confirm there is no leakage of refrigerant gas. It may generate toxic gas when the refrigerant contacts with fire.
17.	Ventilate the room if there is refrigerant gas leakage during operation. Extinguish all fire sources if present. It may cause toxic gas when the refrigerant contacts with fire.
18.	Only use the supplied or specified installation parts, else, it may cause unit vibrate loose, water/refrigerant leakage, electrical shock or fire.

 **WARNING**

19. The unit is only for use in a closed portable water system. Utilization in an open water circuit or non-portable water circuit, may lead to excessive corrosion of the water piping and risk of incubating bacteria colonies, particularly Legionella, in water.	
20. Do not insert your fingers or other objects into the unit, high speed rotating fan may cause injury.	
21. Do not dismantle refrigerant piping using pipe wrench. It might deform the piping and cause the unit to malfunction.	
22. Select a location where in case of water leakage, the leakage will not cause damage to other properties.	
23. Do not locally purchase electrical parts of the product for the purpose of installation, service, maintenance and etc. They might cause electrical shock or fire.	
24. Do not branch the power from terminal block to heater tape. Overloaded terminal block will cause electrical shock or fire.	
25. Installation or servicing work. It may need four or more people to carry out the installation or servicing work.	
26. Do not use unspecified cord, modified cord, joint cord or extension cord for power supply cord. Do not share the single outlet with other electrical appliances. Poor contact, poor insulation or over current will cause electrical shock or fire.	
27. Tighten the flare nut with torque wrench according to specified method. If the flare nut is over-tightened, after a long period, the flare may break and cause refrigerant gas leakage.	

 **CAUTION**

1. Do not install the monobloc unit at place where leakage of flammable gas may occur. In case gas leaks and accumulates at surrounding of the monobloc unit, it may cause fire.	
2. Carry out drainage piping as mentioned in installation instructions. If drainage is not perfect, water may enter the room and damage the furniture.	
3. It may need four or more persons to carry out the installation work. The weight of monobloc unit might cause injury if carried by less than four person.	
4. Do not touch monobloc unit air inlet and aluminium fin. It may cause injury.	
5. Select an installation location which is easy for maintenance.	
6. Pb free solder has a higher melting point than standard solder; typically the melting point is 50°F - 70°F (30°C - 40°C) higher. Please use a high temperature solder iron. In case of the soldering iron with temperature control, please set it to 700 ± 20°F (370 ± 10°C). Pb free solder will tend to splash when heated too high (about 1100°F/600°C).	
7. Power supply connection to the monobloc unit. <ul style="list-style-type: none">• Power supply point should be in easily access ble place for power disconnection in case of emergency.• Must follow local national wiring standard, regulation and this installation instruction.• Strongly recommended to make permanent connection to a circuit breaker. It must be a double pole switch with a minimum 3.0mm gap.<ul style="list-style-type: none">- Use approved 30A circuit breaker for power supply 1- Use approved 30A circuit breaker for power supply 2- Use approved 15A/16A circuit breaker for power supply 3	
8. Do not release refrigerant during piping work for installation, servicing, re-installation and during repairing a refrigeration parts. Take care of the liquid refrigerant, it may cause frostbite.	
9. Do not install this appliance in a laundry room or other high humidity location. This condition will cause rust and damage to the unit.	
10. Make sure the insulation of power supply cord does not contact to hot part (i.e. refrigerant piping, water piping) to prevent from insulation failure (melt).	
11. Do not sit, step or place anything on the unit, you may fall down accidentally.	
12. Do not touch the sharp aluminum fins or edges of metal parts. If you are required to handle sharp parts during installation or servicing, please wear hand glove. Sharp parts may cause injury.	
13. After installation, check the water leakage condition in connection area during test run. If leakage occur, it will cause damage to other properties.	
14. The unit described in this manual is designed for use in a closed water system only. Utilization in an open water circuit may lead to excessive corrosion of the water piping.	

2. Specifications

2.1 WH-MDF06D3E5

Item		Unit	Refrigerant System	
Performance Test Condition			EN 14511	
Heating Capacity	Condition (Ambient/Water)		A7W35	A2W35
	kW		6.00	5.00
	BTU/h		20500	17100
	kcal/h		5160	4300
COP	W/W		4.41	3.40
	kcal/hW		3.79	2.93
Air Flow	m ³ /min (ft ³ /min)		46.7 (1649)	
Refrigeration Control Device			Expansion Valve	
Refrigeration Oil	cm ³		FV50S (900)	
Refrigerant (R410A)	kg (oz)		1.45 (51.2)	
Pipe Diameter	Liquid	mm (inch)	9.52 (3/8)	
	Gas	mm (inch)	15.88 (5/8)	
Compressor	Type		Hermetic Motor	
	Motor Type		Brushless (4-poles)	
	Rated Output	kW	1.70	
Fan	Type		Propeller Fan	
	Material		PP	
	Motor Type		Induction (8-poles)	
	Input Power	W	—	
	Output Power	W	60	
	Fan Speed	rpm	580	
Heat Exchanger	Fin material		Aluminium (Pre Coat)	
	Fin Type		Corrugated Fin	
	Row × Stage × FPI		2 × 30 × 17	
	Size (W × H × L)	mm	38.1 × 762 × 903.8 873.8	

Item		Unit	Monobloc Unit	
Dimension	Height	mm (inch)	865 (34 - 1/16)	
	Width	mm (inch)	1283 (50 - 17/32)	
	Depth	mm (inch)	320 (12 - 5/8)	
Net Weight		kg (lbs)	112 (247)	
Noise Level		dB-A	47	-
		Power Level dB	65	-
Power Source (Phase, Voltage, Cycle)		ø	Single	
		V	230	
		Hz	50	
Input Power		kW	1.36	1.47
Maximum Input Power For Monobloc Unit		kW	4.48	
Power Supply 1: Phase (ø) / Max. Current (A) / Max. Input Power (W)			Single / 20.5 / 4.48k	
Power Supply 2: Phase (ø) / Max. Current (A) / Max. Input Power (W)			Single / 26.0 / 6.00k	
Power Supply 3: Phase (ø) / Max. Current (A) / Max. Input Power (W)			- / - / -	
Starting Current		A	6.2	
Running Current		A	6.2	6.7
Maximum Current For Monobloc Unit		A	20.5	
Power Factor		%	95	

Item		Unit	Monobloc Unit
Power factor means total figure of compressor and outdoor fan motor.			
Power Cord	Number of core		-
	Length	m (ft)	-
Thermostat			Electronic Control
Protection Device			Electronic Control

Item		Unit	Water System
Performance Test Condition			EN 14511
Operation Range	Outdoor Ambient	°C	-20 ~ 35
	Water Outlet	°C	25 ~ 55
Internal Pressure Differential		kPa	23.4
Refrigerant Pipe Diameter	Liquid	mm (inch)	9.52 (3/8)
	Gas	mm (inch)	15.88 (5/8)
Water Pipe Diameter	Inlet	mm (inch)	30 (1-3/16)
	Outlet	mm (inch)	30 (1-3/16)
Water Drain Hose Inner Diameter		mm (inch)	15.00 (19/32)
Pump	Motor Type		Capacitor Run Induction Motor (2.5 µF)
	No. of Speed		3
	Input Power	W	75
Hot Water Coil	Type		Brazed Plate
	No. of Plates		48
	Size (W x H x L)	mm	93 x 81 x 325
	Water Flow Rate	l/min (m ³ /h)	17.2 (1.0)
Pressure Relief Valve Water Circuit		kPa	Open: 300, Close: 186 and below
Flow Switch			Magnetic Lead Switch
Protection Device		A	Residual Current Circuit Breaker (40)
Expansion Vessel	Volume	l	6
	MWP	bar	1
Capacity of Integrated Electric Heater		kW	3.00

Note:

- Heating capacities are based on outdoor air temperature of 7°C Dry Bulb (44.6°F Dry Bulb), 6°C Wet Bulb (42.8°F Wet Bulb) with controlled water inlet temperature of 30°C and water outlet temperature of 35°C.
- Specification are subjected to change without prior notice for further improvement.

2.2 WH-MDF09D3E5

Item		Unit	Refrigerant System	
Performance Test Condition			EN 14511	
Heating Capacity	Condition (Ambient/Water)		A7W35	A2W35
	kW		9.00	7.00
	BTU/h		30700	23900
	kcal/h		7740	6020
COP	W/W		4.10	3.00
	kcal/hW		3.52	2.58
Air Flow	m ³ /min (ft ³ /min)		51.6 (1822)	
Refrigeration Control Device			Expansion Valve	
Refrigeration Oil	cm ³		FV50S (900)	
Refrigerant (R410A)	kg (oz)		1.45 (51.2)	
Pipe Diameter	Liquid	mm (inch)	9.52 (3/8)	
	Gas	mm (inch)	15.88 (5/8)	
Compressor	Type		Hermetic Motor	
	Motor Type		Brushless (4-poles)	
	Rated Output	kW	1.70	
Fan	Type		Propeller Fan	
	Material		PP	
	Motor Type		Induction (8-poles)	
	Input Power	W	—	
	Output Power	W	60	
	Fan Speed	rpm	640	
Heat Exchanger	Fin material		Aluminium (Pre Coat)	
	Fin Type		Corrugated Fin	
	Row × Stage × FPI		2 × 30 × 17	
	Size (W × H × L)	mm	38.1 × 762 × 903.8 873.8	

Item		Unit	Monobloc Unit	
Dimension	Height	mm (inch)	865 (34 - 1/16)	
	Width	mm (inch)	1283 (50 - 17/32)	
	Depth	mm (inch)	320 (12 - 5/8)	
Net Weight		kg (lbs)	112 (247)	
Noise Level		dB-A	49	-
		Power Level dB	67	-
Power Source (Phase, Voltage, Cycle)		ø	Single	
		V	230	
		Hz	50	
Input Power		kW	2.20	2.33
Maximum Input Power For Monobloc Unit		kW	5.01	
Power Supply 1: Phase (ø) / Max. Current (A) / Max. Input Power (W)			Single / 22.9 / 5.01k	
Power Supply 2: Phase (ø) / Max. Current (A) / Max. Input Power (W)			Single / 26.0 / 6.00k	
Power Supply 3: Phase (ø) / Max. Current (A) / Max. Input Power (W)			- / - / -	
Starting Current		A	10.1	
Running Current		A	10.1	10.7
Maximum Current For Monobloc Unit		A	22.9	
Power Factor		%	95	

Item	Unit	Monobloc Unit
Power factor means total figure of compressor and outdoor fan motor.		
Power Cord	Number of core	-
	Length	m (ft)
Thermostat		Electronic Control
Protection Device		Electronic Control

Item	Unit	Water System
Performance Test Condition		EN 14511
Operation Range	Outdoor Ambient	°C
	Water Outlet	°C
Internal Pressure Differential		kPa
Refrigerant Pipe Diameter	Liquid	mm (inch)
	Gas	mm (inch)
Water Pipe Diameter	Inlet	mm (inch)
	Outlet	mm (inch)
Water Drain Hose Inner Diameter		mm (inch)
Pump	Motor Type	Capacitor Run Induction Motor (2.5 µF)
	No. of Speed	3
	Input Power	W
Hot Water Coil	Type	Brazed Plate
	No. of Plates	48
	Size (W x H x L)	mm
	Water Flow Rate	l/min (m ³ /h)
Pressure Relief Valve Water Circuit		kPa
Flow Switch		Open: 300, Close: 186 and below
Protection Device		Magnetic Lead Switch
Protection Device		A
Protection Device		Residual Current Circuit Breaker (40)
Expansion Vessel	Volume	l
	MWP	bar
Capacity of Integrated Electric Heater		kW

Note:

- Heating capacities are based on outdoor air temperature of 7°C Dry Bulb (44.6°F Dry Bulb), 6°C Wet Bulb (42.8°F Wet Bulb) with controlled water inlet temperature of 30°C and water outlet temperature of 35°C.
- Specification are subjected to change without prior notice for further improvement.

3. Features

- **Inverter Technology**
 - Energy saving
- **High Efficiency**
- **Compact Design**
- **Environment Protection**
 - Non-ozone depletion substances refrigerant (R410A)
- **Easy to use remote control**
- **Weekly Timer setting**
- **Quality Improvement**
 - Random auto restart after power failure for safety restart operation
 - Gas leakage protection
 - Prevent compressor reverse cycle
 - Inner protector to protect compressor
- **Serviceability Improvement**
 - Breakdown Self Diagnosis function
 - System Status Check Buttons for servicing purpose
 - System Pumpdown Button for servicing purpose
 - Front maintenance design for monobloc unit
- **Operation Condition**

		Water outlet temperature (°C)	Ambient temperature (°C)
HEATING	Maximum	55	35
	Minimum	25	-20

NOTICE : When the outdoor temperature is out of the above temperature range, the heating capacity will drop significantly and monobloc unit might stop for protection control.

4. Location of Controls and Components

4.1 Monobloc Unit

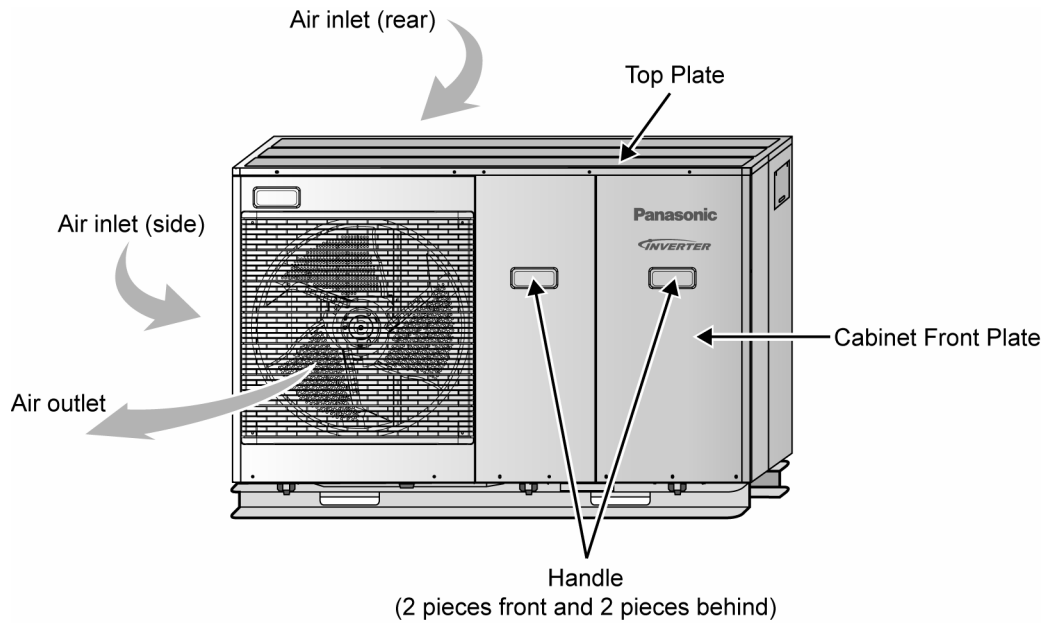

4.1.1 Main Components

<Top View>

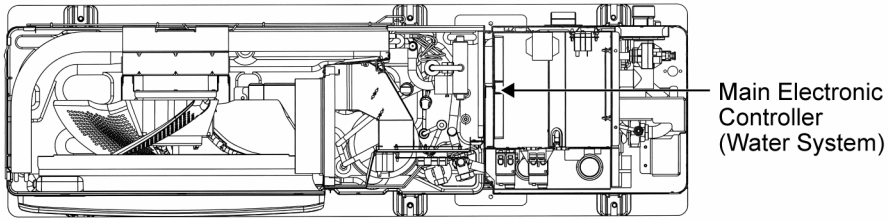

<Front View>

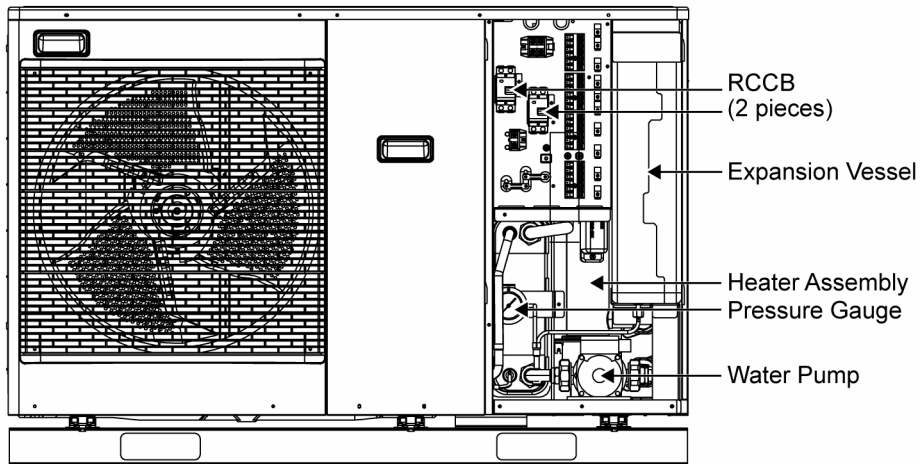

<Side View>

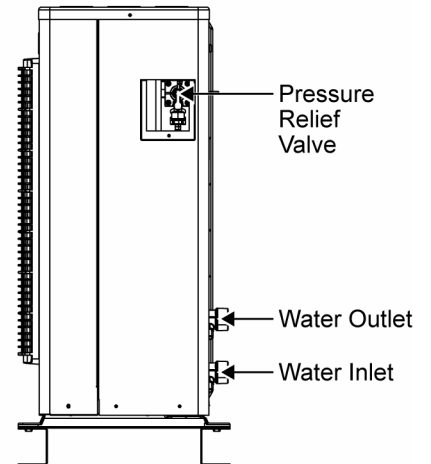

- Water pump: The pump circulates the water in the water circuit.
- Pressure gauge: The manometer allows read out of the water pressure in the water circuit.
- Flow switch: The flow switch checks the flow in the water circuit and protects the heat exchanger against high pressure built-up and the pump against damage.
- Pressure relief valve: The pressure relief valve prevents excessive water pressure in the water circuit (> 190kPa).
- Electric Heater: Additional heating capacity to the system when water and ambient temp is low.
- Expansion Vessel: Storage for excessive water.

4.1.2 Location of Control

4.1.2.1 Remote Control

The user interface allows the installer and user to setup, use and maintain the unit.

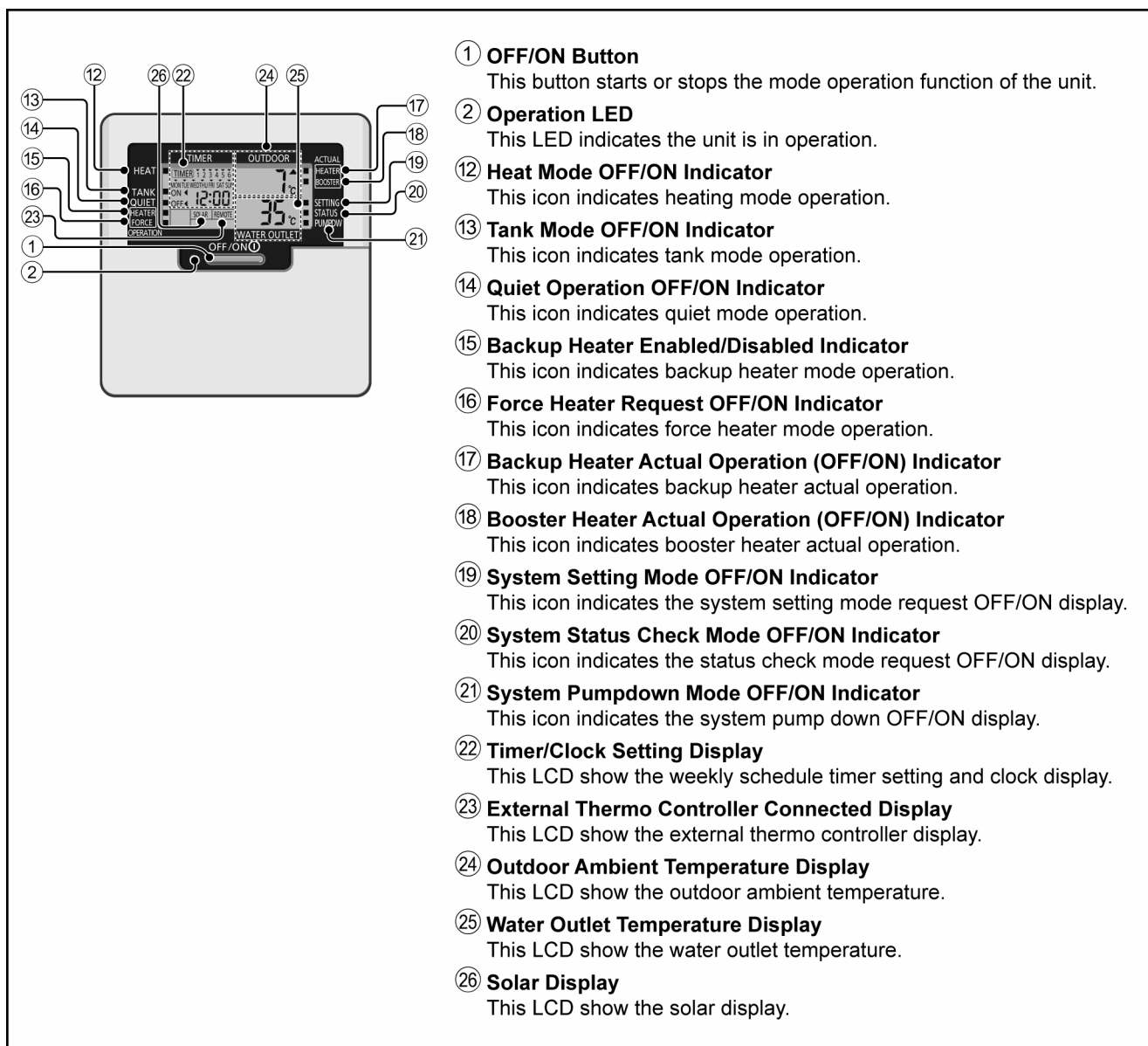

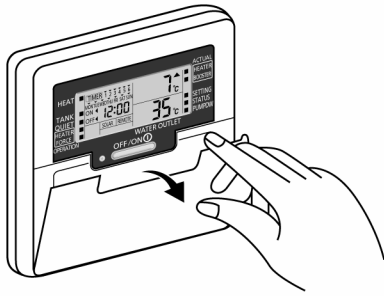

Open cover for buttons selections.

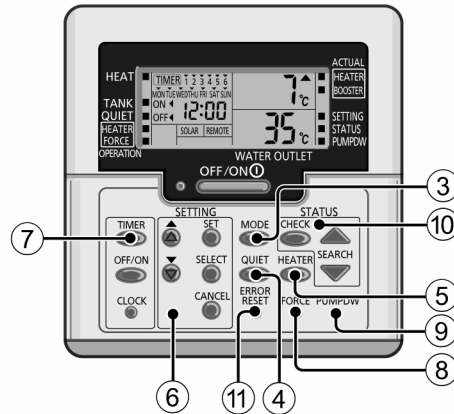

⑥ System Setting Mode Buttons

These setting button can change the temperature range of setup setting mode selection. Perform the steps below to set preferred temperature range.

STEP 1: Press SET button for 5 seconds to enter setting mode.

STEP 2: Press upward or downward button to choose the 7 of the parameter as below for change the temperature range.

- 1) Outdoor ambient set temperature for heat mode at low water outlet temperature (Selection range: $-15^{\circ}\text{C} \sim 15^{\circ}\text{C}$).
- 2) Outdoor ambient set temperature for heat mode at high water outlet temperature (Selection range: $-15^{\circ}\text{C} \sim 15^{\circ}\text{C}$).
- 3) Water outlet set temperature for heat mode at low outdoor ambient temperature (Selection range: $25^{\circ}\text{C} \sim 55^{\circ}\text{C}$).
- 4) Water outlet set temperature for heat mode at high outdoor ambient temperature (Selection range: $25^{\circ}\text{C} \sim 55^{\circ}\text{C}$).
- 5) Set temperature for turning OFF heating operation (Selection range: $5^{\circ}\text{C} \sim 35^{\circ}\text{C}$).
- 6) Outdoor ambient set temperature for turning ON heater operation (Selection range: $-15^{\circ}\text{C} \sim 20^{\circ}\text{C}$).
- 7) Sanitary tank set temperature (Selection range: $40^{\circ}\text{C} \sim 75^{\circ}\text{C}$).

STEP 3: Press SELECT button to enter selected parameter.

STEP 4: Press upward or downward button to set desired temperature.

STEP 5: Press SET button again to confirm the setting.

Note: Repeat steps 2 to 5 to set other parameters.

STEP 6: Press CANCEL button or wait 30 seconds to exit setting mode.

Water Temperature Thermo Shift Setting

Perform the steps below to set the desired shift temperature.

STEP 1: Press SET button within 5 seconds.

STEP 2: Press SELECT button to enter the setting temperature.

STEP 3: Press upward or downward button to set desired temperature (Selection range: $-5^{\circ}\text{C} \sim 5^{\circ}\text{C}$).

STEP 4: Press SET button again to confirm the setting.

STEP 5: Press CANCEL button or wait 30 seconds to exit setting.

⑪ **Error Reset Button**

This button is to reset the remote control and system error code.

⑨ **System Pumpdown Mode Button**

This button is to select the pump down operation (Press 5 seconds)
Press OFF/ON button to stop the pump down operation.

⑩ **System Status Check Mode Buttons**

This button is to check the various mode status.

Perform the steps below to check the selection status.

STEP 1: Press CHECK button for 5 seconds to enter status mode.

STEP 2: Press SEARCH Upward or Downward buttons for checking below value.

1. Compressor running frequency

2. Error history

3. Water inlet temperature

4. Tank Temperature

STEP 3: Press CANCEL button at setting mode or wait 30 seconds to exit status check.

⑦ **Timer Setting Group Buttons**

This button is to set weekly timer and clock-time combine with setting button.

Perform the steps below to setting the current day and time.

STEP 1: Press CLOCK button.

STEP 2: Press SETTING Upward or Downward buttons to set current day.

STEP 3: Press SET button to confirm.

STEP 4: Repeat STEP 2 and 3 to set the current time.

Note: The current time that has been set will be the standard time for all the Timer Operations.

③ **Operation Mode Button**

This button is to set operation mode.

The mode does the following transition by button operation.

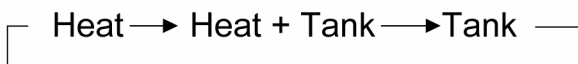

④ **Quiet Operation Button**

This button is to enjoy quiet environment by reduces monobloc unit noise.

⑧ **Force Heater Mode Button**

This button is to select force heater mode operation.

Press OFF/ON button to stop the force heater mode operation.

⑤ **Backup Heater Enabling Button**

This button is to select backup heater mode operation.

4.1.3 Weekly Timer Setting

Timer Display

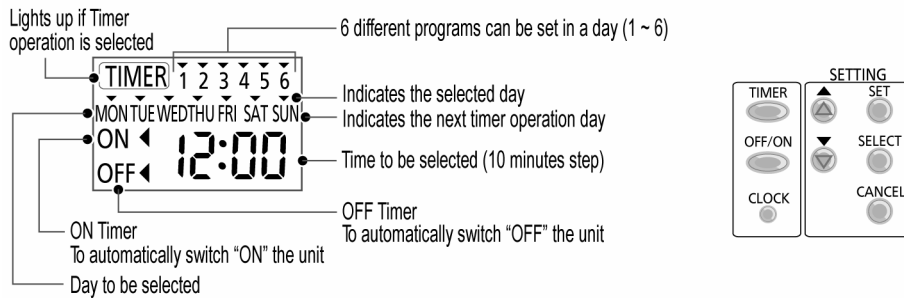

Function	Step
Enter timer mode	Press .
Set day & time	<ol style="list-style-type: none"> 1. Press or to select your desired day. 2. Press to confirm 3. "1" will be blinking, press to set program 1. 4. Press to select ON or OFF timer. 5. Press or to select your desired time. If you want to set the timer together with other operations, press and . 6. Press to confirm program 1. The selected day will be highlighted with . • After 2 seconds, the display will move to the next program. 7. Repeat steps 4 to 7 to set programs 2 to 6. • During timer setup, if no button is pressed within 30 seconds, or if the button is pressed the setting at that moment is confirmed and timer setup is ended.
Add/Modify timer	Repeat the steps above.
Disable timer	Press , then press .
Enable timer	Press , then press .
Check timer	<ol style="list-style-type: none"> 1. Press . 2. Press or until your desired day is shown, press to confirm your selection. 3. Press or to check the set programs.
Cancel timer	<ol style="list-style-type: none"> 1. Press . 2. Press or until your desired day is shown. 3. Press to enter program setting. 4. Press or until your desired program is shown. 5. Press to cancel the program.

Notes:

- You can set the Timer for each day of the week (Monday to Sunday) with 6 programs per day.
- When the unit is switched on by the ON Timer, it will use the previously set temperature to control the water outlet temperature.
- Same timer program cannot be set in the same day.
- You may also select collective days with same timer setting.
- Promotes energy saving by allowing you to set up to 6 programs in any given day.

4.1.4 Setting Up The Special Functions

- After initial installation, you can manually adjust the settings. The initial setting remains active until the user changes it.
- The remote control can be used for multiple installations. Some functions may not be applicable to your unit.
- Ensure the operation LED is in OFF condition before setting.

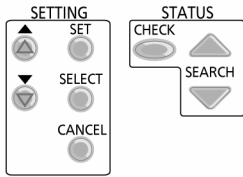
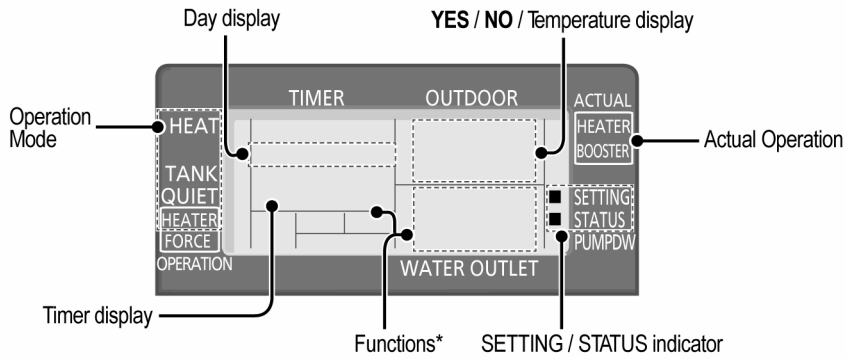

SELECT FUNCTIONS AND SET YOUR DESIRED TIMER

1. Press **SET** and **CHECK** simultaneously for 5 seconds to enter special setting mode. "SETTING" and "STATUS" indicator is ON.
2. Press **▲** or **▼** to browse functions.
3. Press **SELECT** to enter the function.
4. Press **▲** or **▼** to enable **YES** or disable **NO** function, or set your desired day and time.
5. Press **SET** to confirm.

Function *	Operation Mode/ Actual Operation	Description
con	ro on	External Thermo Controller (YES / NO) To set external thermo controller connection.
con	TANK	Tank Connection (YES / NO) To set tank connection.
PrY	SOLAR	Solar Priority (YES / NO) To choose the solar use for water tank heat up.
PrY	HEAT	Heating Priority (YES / NO) To choose the heat pump only use for Heating side during HEAT + TANK mode.
int	HEAT	Heating Heat-up Interval Set To set timer for Heating during HEAT + TANK mode (0.5hour ~ 10hours).
int	TANK	Tank Heat-up Interval Set To set timer for Tank during HEAT + TANK mode (5minutes ~ 1hour 35minutes).
dLY	BOOSTER	Booster Heater Delay Time Set To set delay timer for booster heater to ON if tank temperature is not reached (20minutes ~ 1hour 35minutes).
Fun	SterL	Sterilization (YES / NO) To set sterilization, if required.
Str		Sterilization Day & Time Set To set timer for sterilization (only once a week).
bo i	SterL	Sterilization Temperature Set To set temperature for sterilization function (40°C ~ 75°C).
oPr	Ster	Sterilization Continue Time To set timer to maintain heating temperature in order to complete the sterilization function (5minutes ~ 1hour).

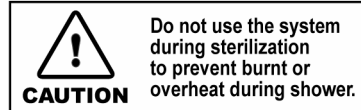

5. Dimensions

5.1 Monobloc Unit

<Top View>

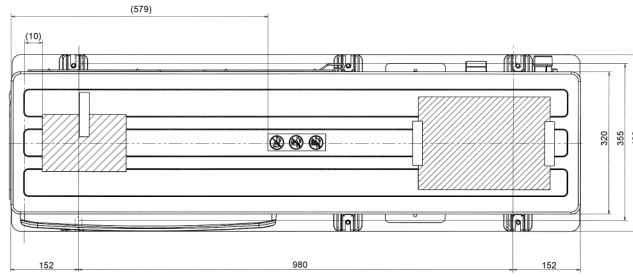

<Front View>

<Side View>

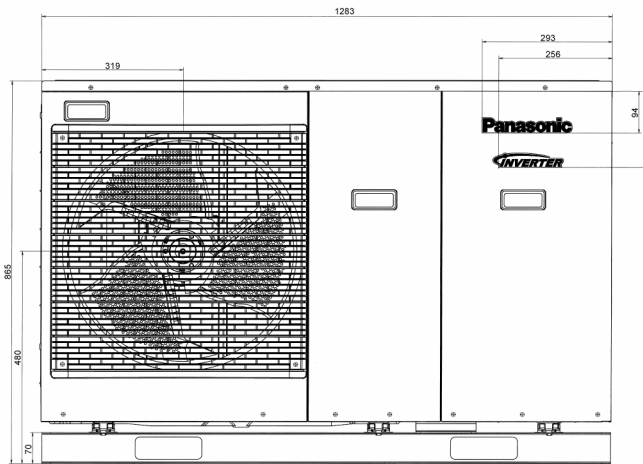
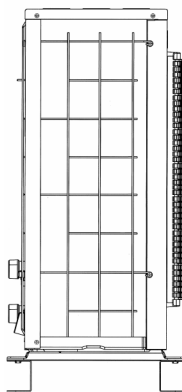

<Side View>

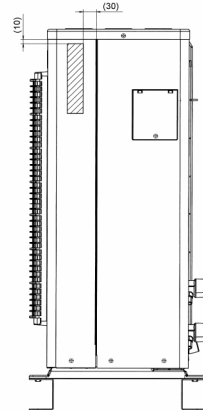

Unit: mm

6. Refrigeration and Water Cycle Diagram

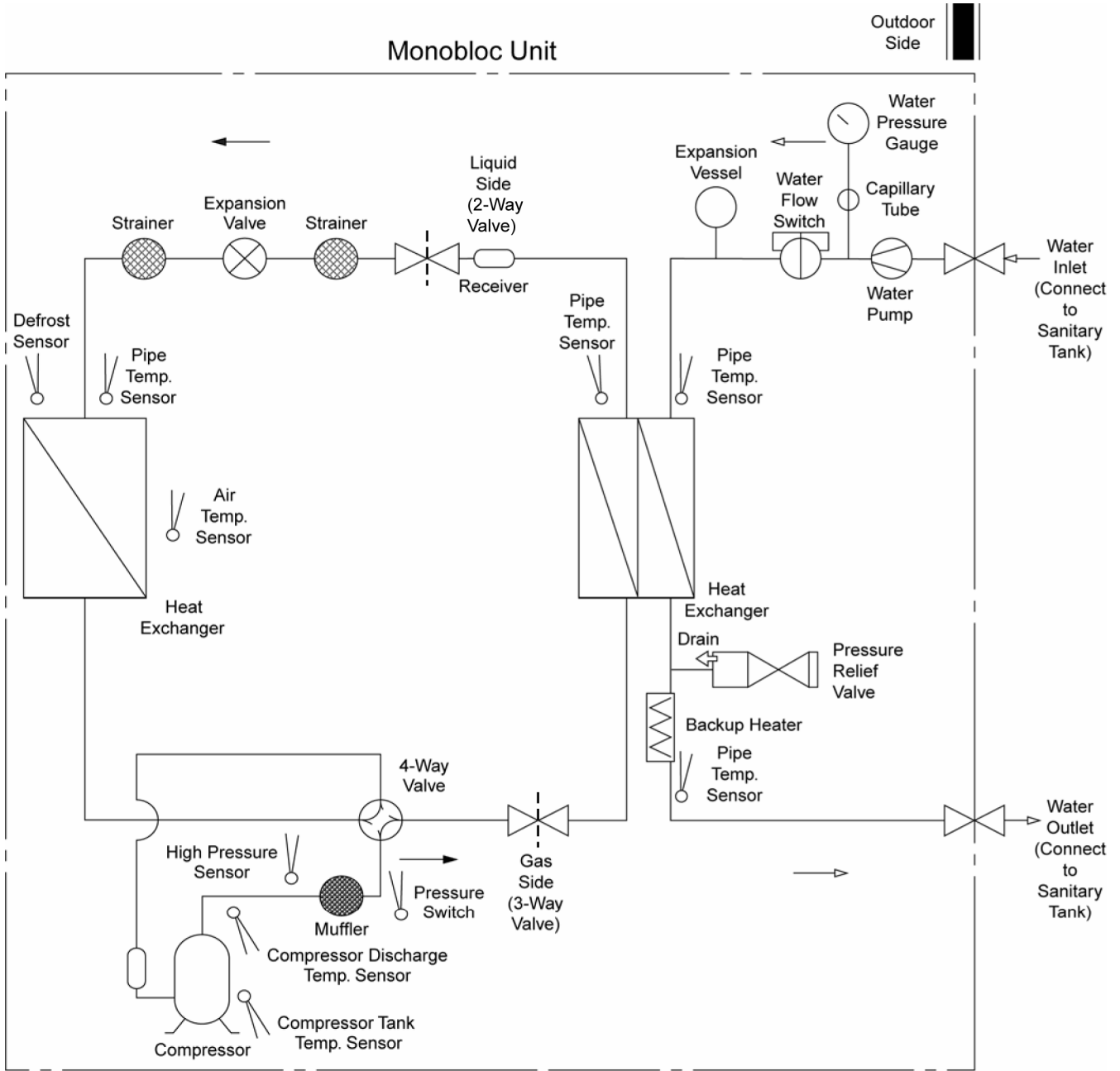

—▶ Refrigerant Cycle (Heating)
 - - -▶ Water Cycle

Indoor Side

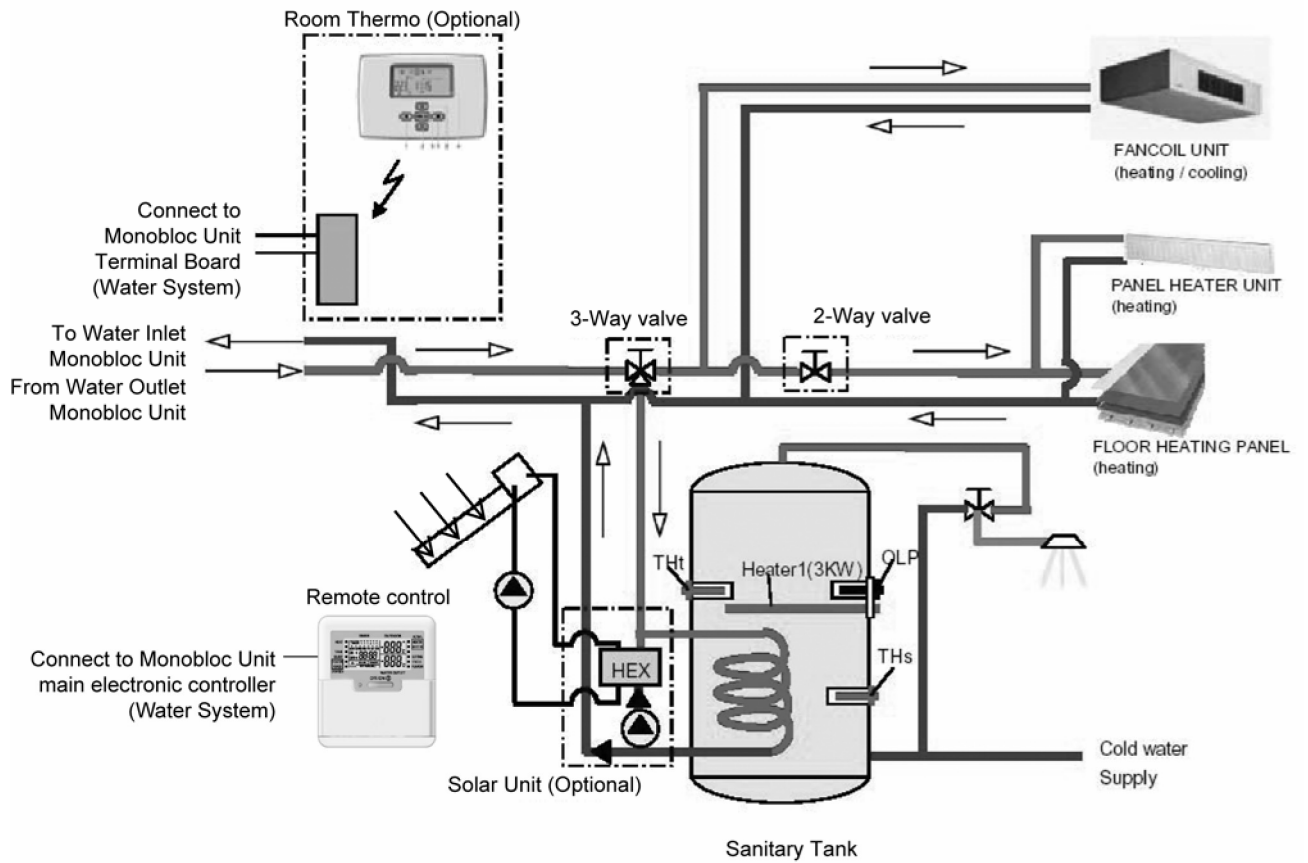

7. Block Diagram

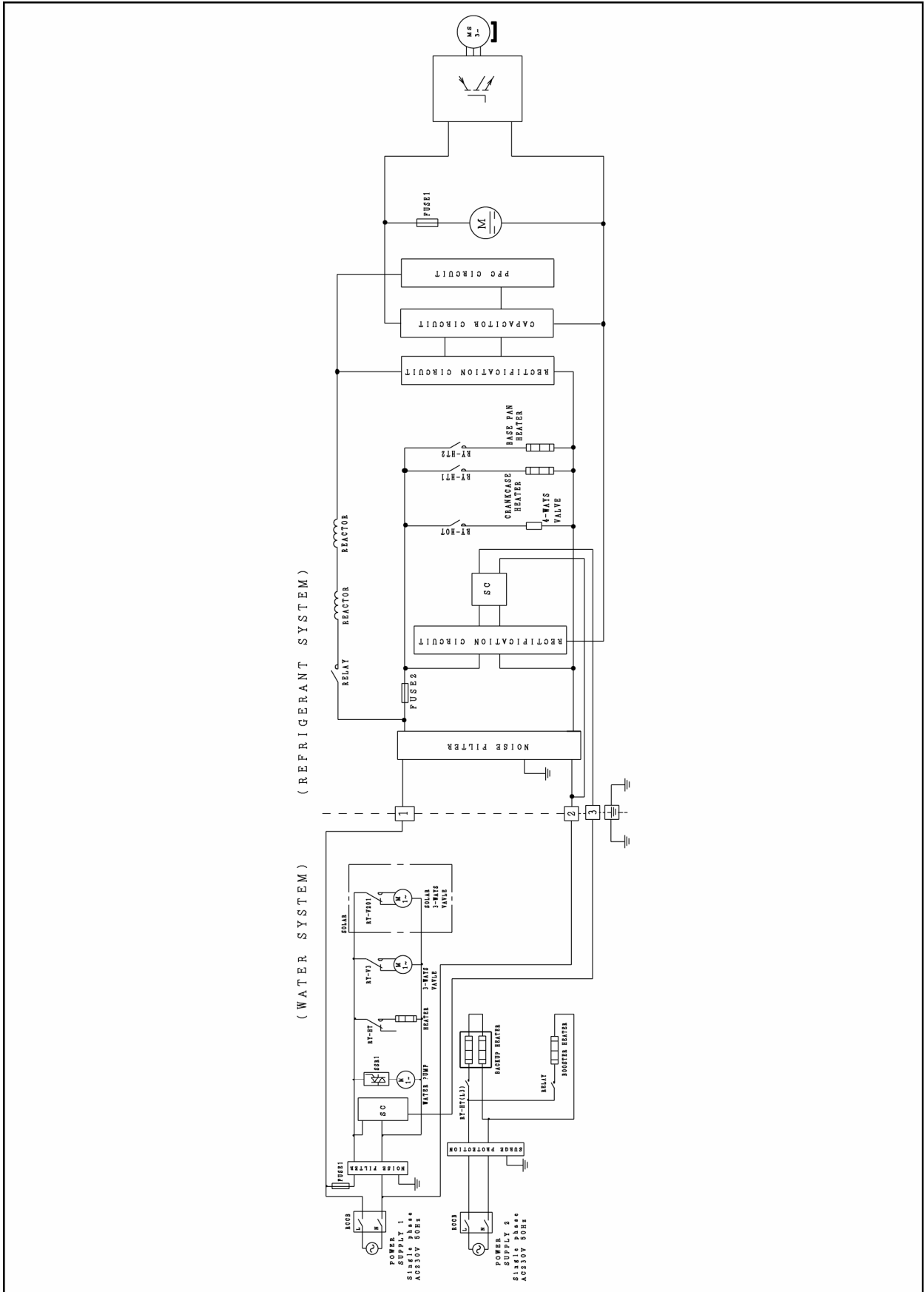

8. Wiring Connection Diagram

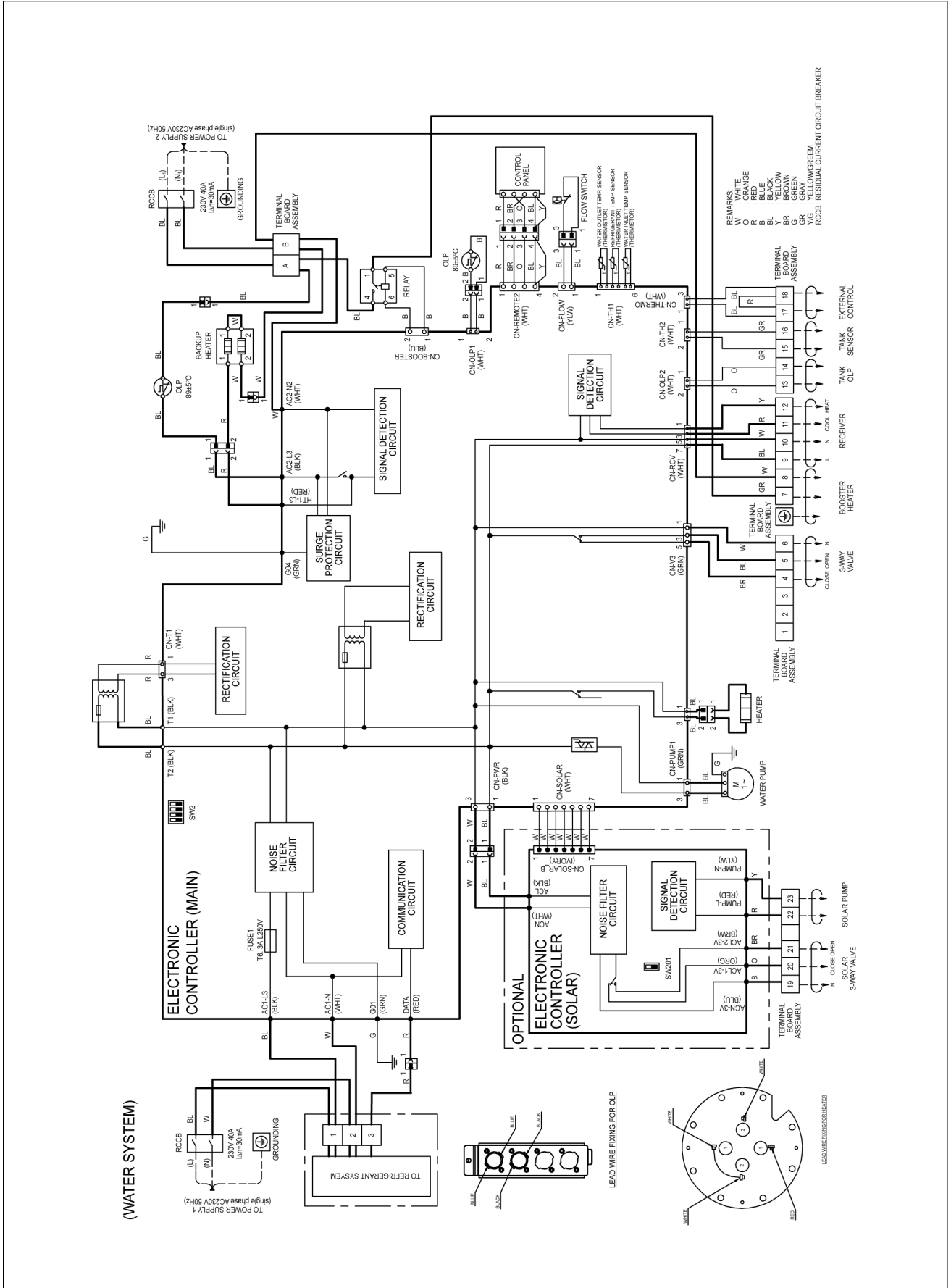

(REFRIGERANT SYSTEM)

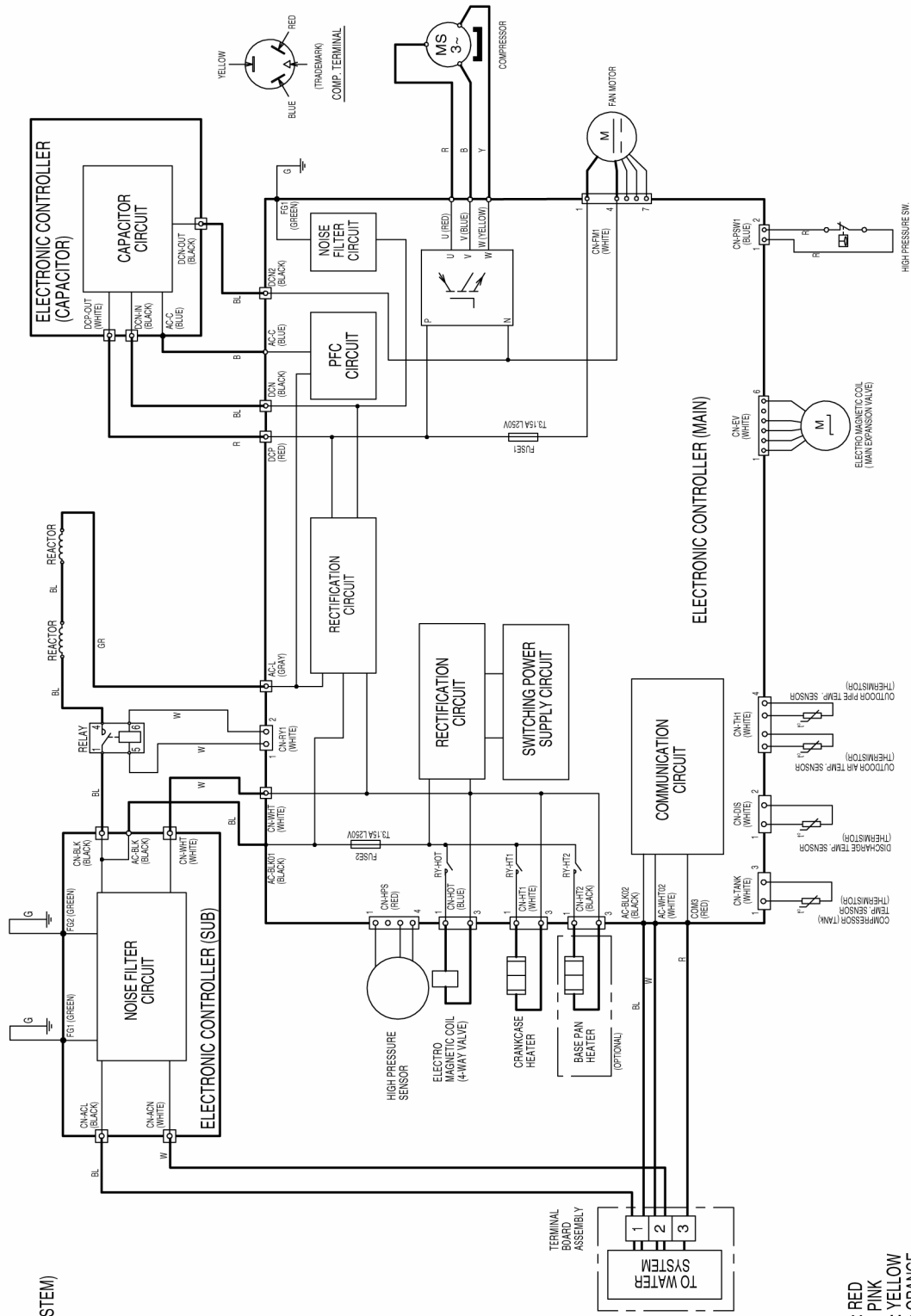

REMARKS:
 R : RED
 W : WHITE
 B : BLUE
 BL : BLACK
 BR : BROWN
 G : GREEN
 Y/G : YELLOW/GREEN
 P : PINK
 Y : YELLOW
 O : ORANGE
 GR : GRAY

9. Electronic Circuit Diagram

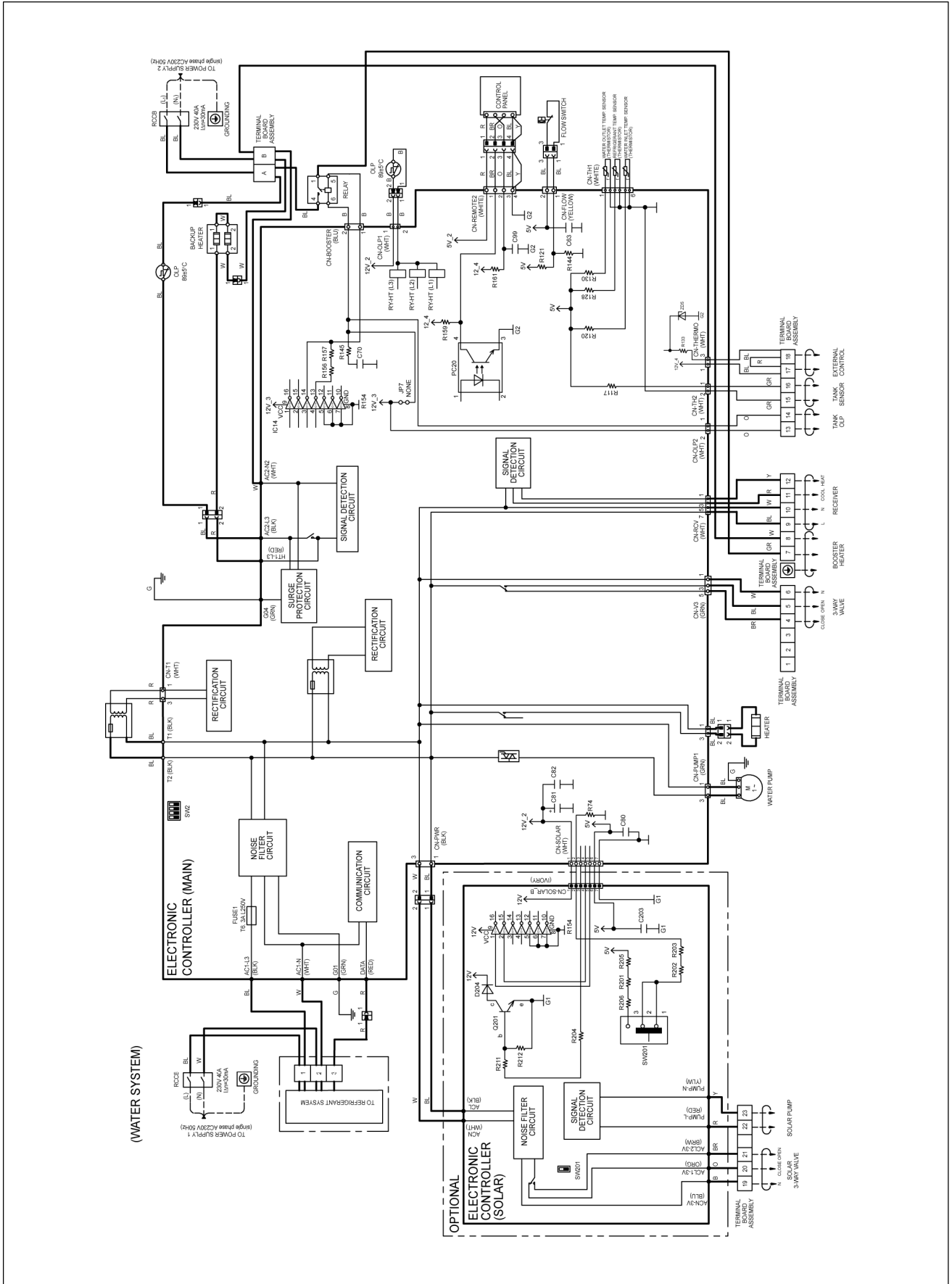

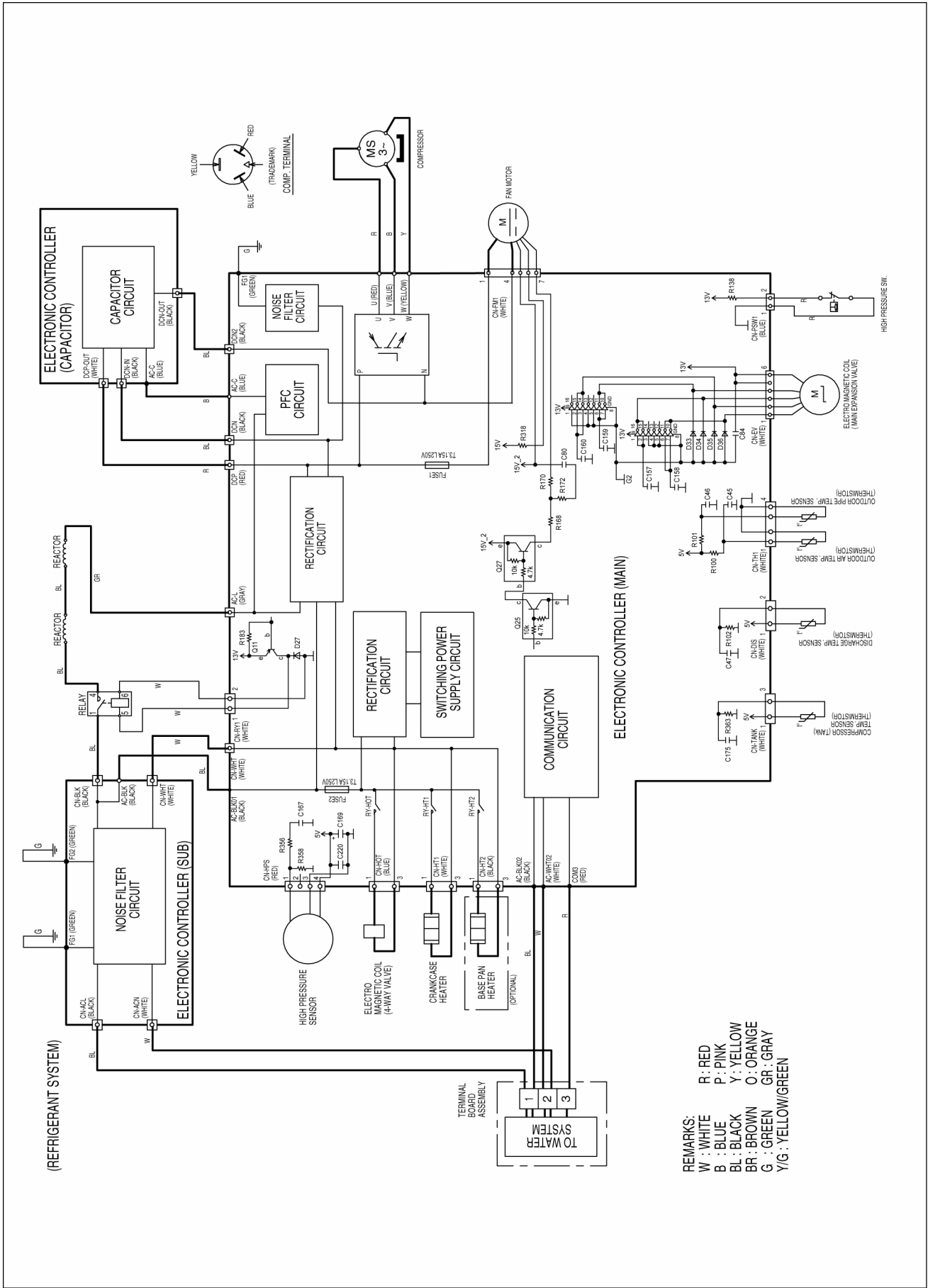

10. Printed Circuit Board

10.1 Water System

10.1.1 Main Printed Circuit Board

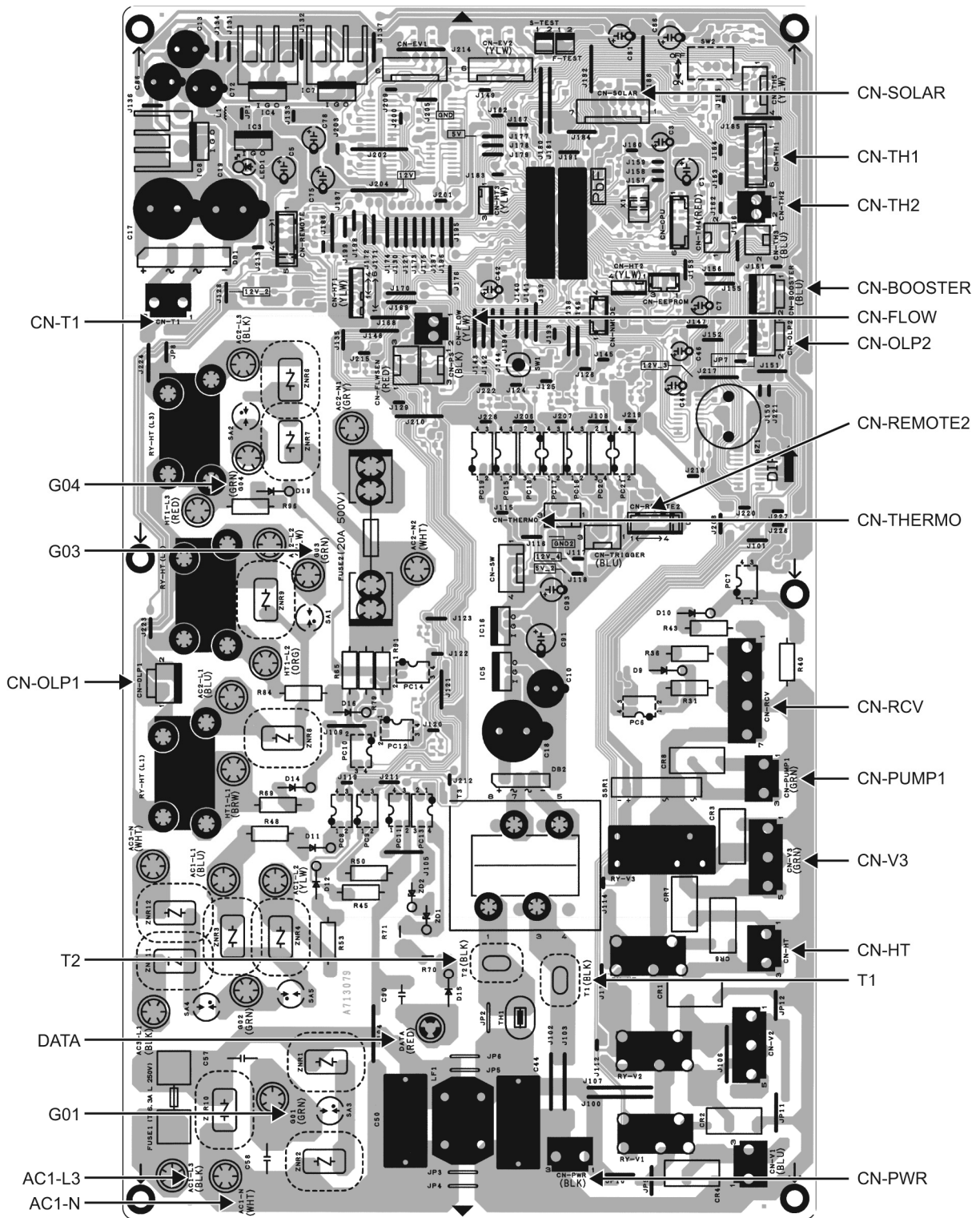

10.1.2 Solar Printed Circuit Board (Optional)

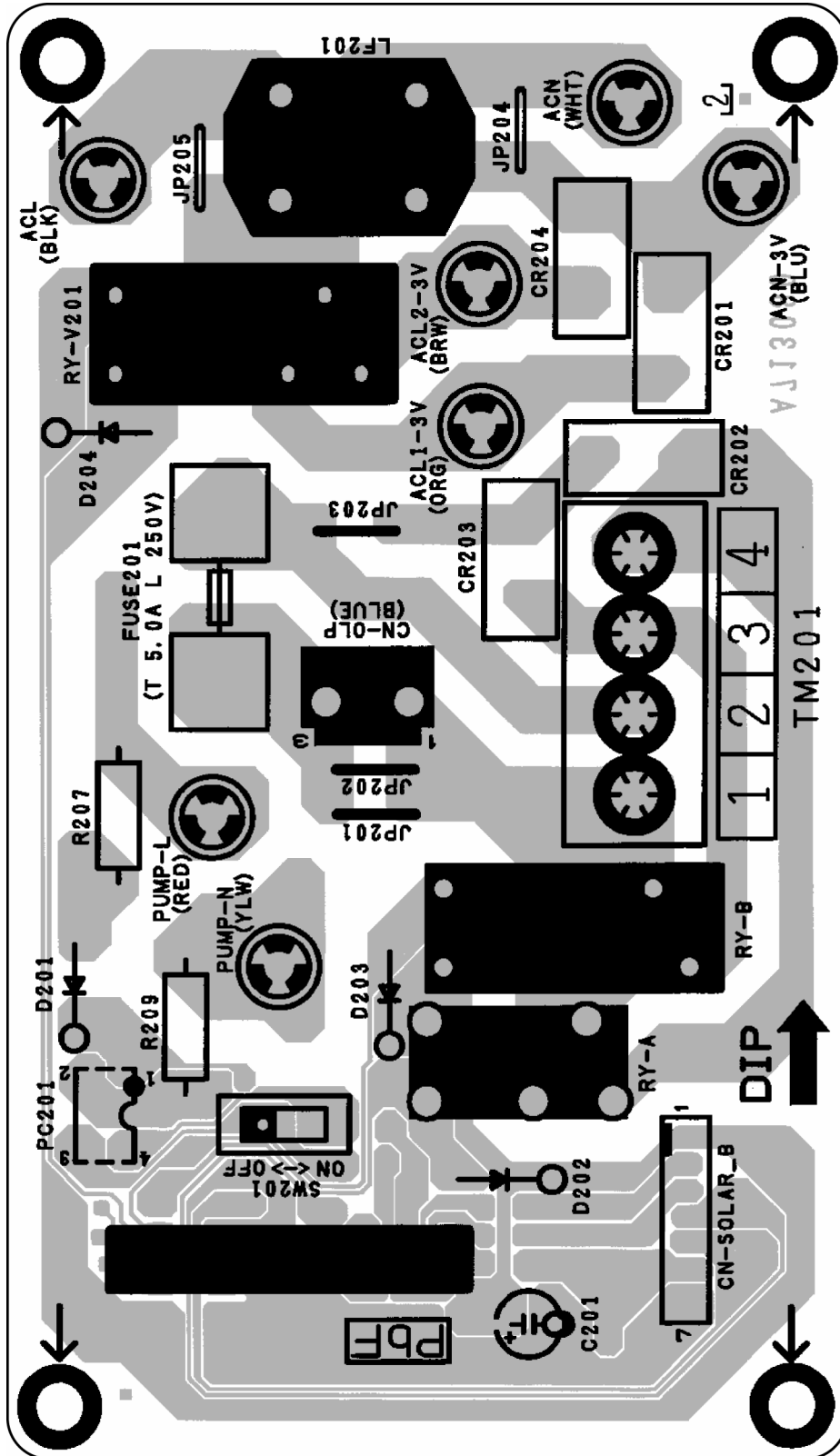

10.2.2 Capacitor Printed Circuit Board

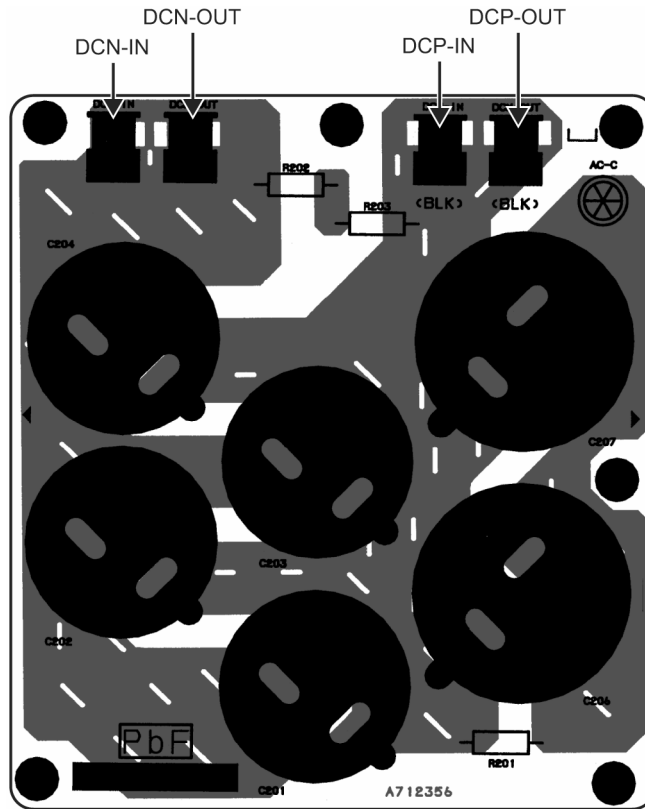

10.2.3 Noise Filter Printed Circuit Board

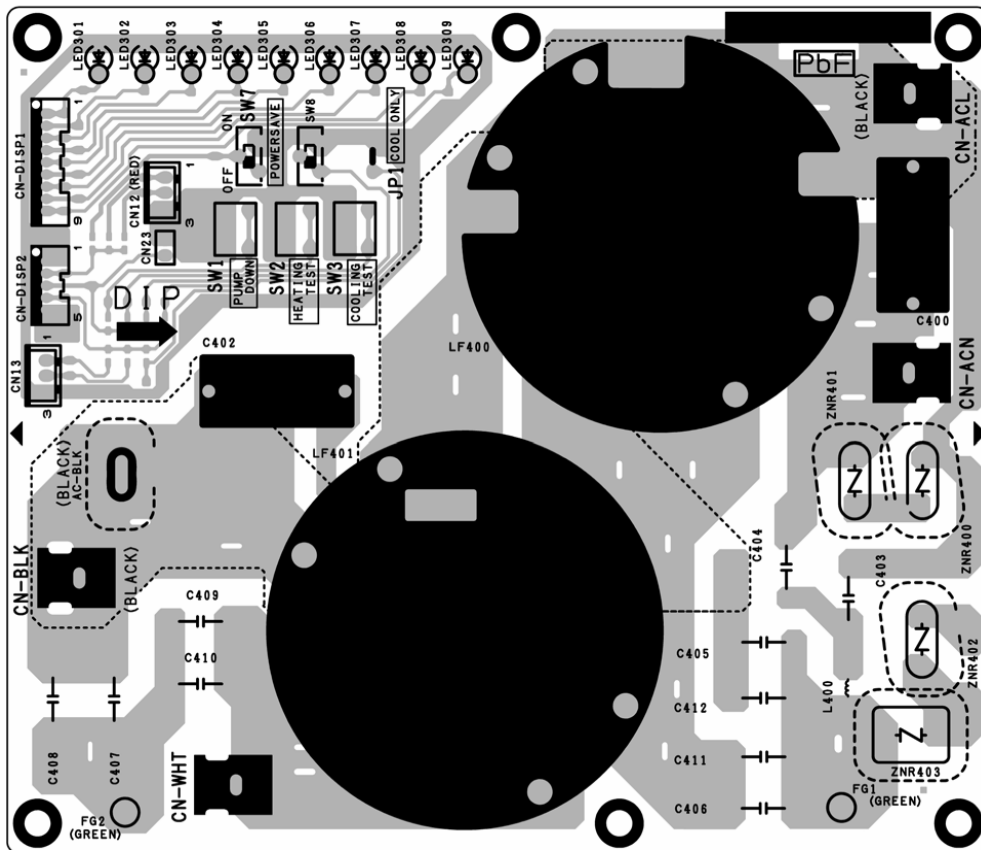

11. Installation Instruction

Monobloc Unit

Dimension Diagram

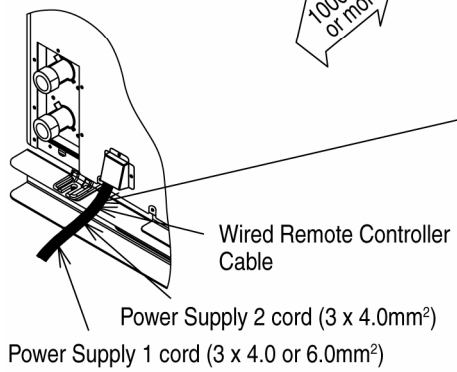
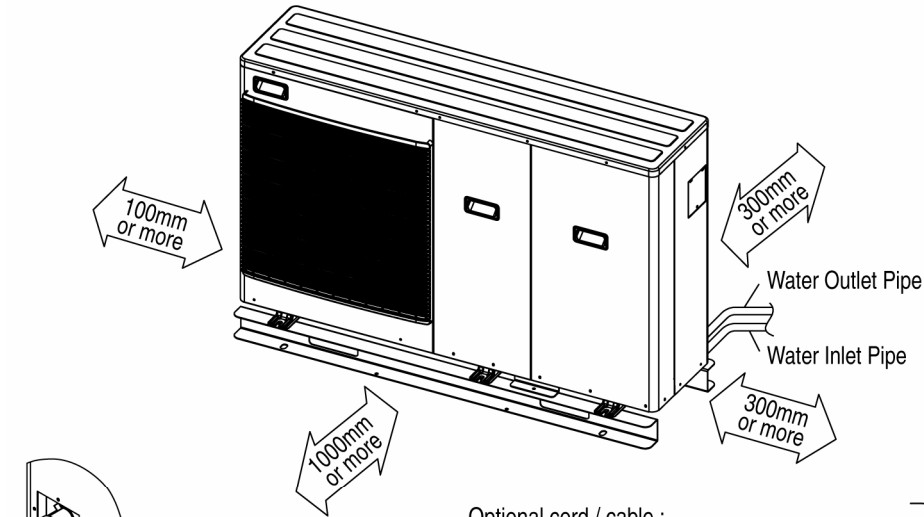
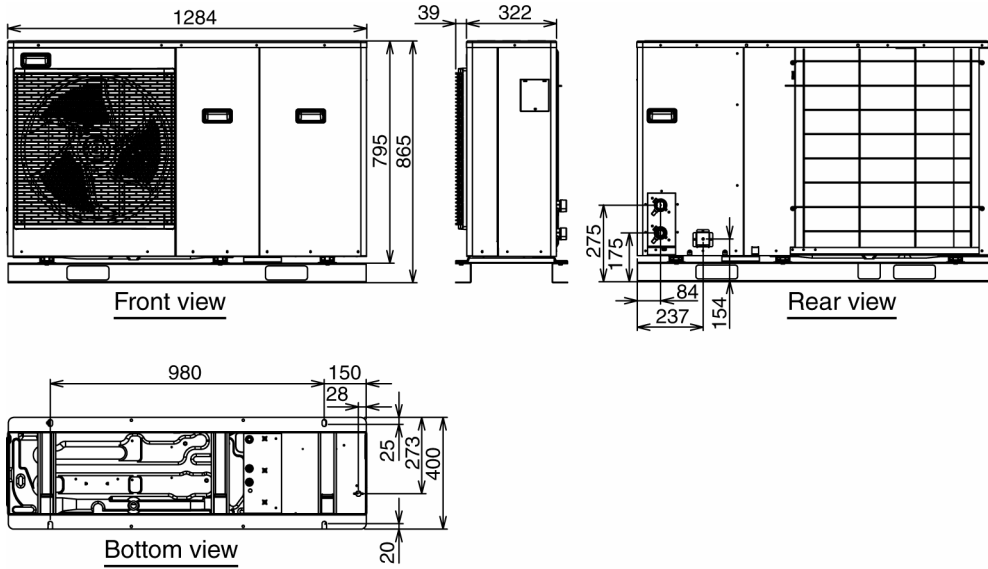

Optional cord / cable :-

- 3-way Valve cable (3 x min 0.5mm²)
- Booster Heater cord (3 x min 1.5mm²)
- Receiver cable (4 or 3 x min 0.5mm²)
- Tank OLP cable (2 x min 0.5mm²)
- Tank Sensor cable (2 x min 0.3mm²)
- External Controller cable (2 x min 0.5mm²)
- Solar Three-way Valve cable (3 x min 0.5mm²)
- Solar Pump Station cable (2 x min 0.5mm²)

Type designation
60245
IEC 57 or
heavier cord/
cable

Main Components

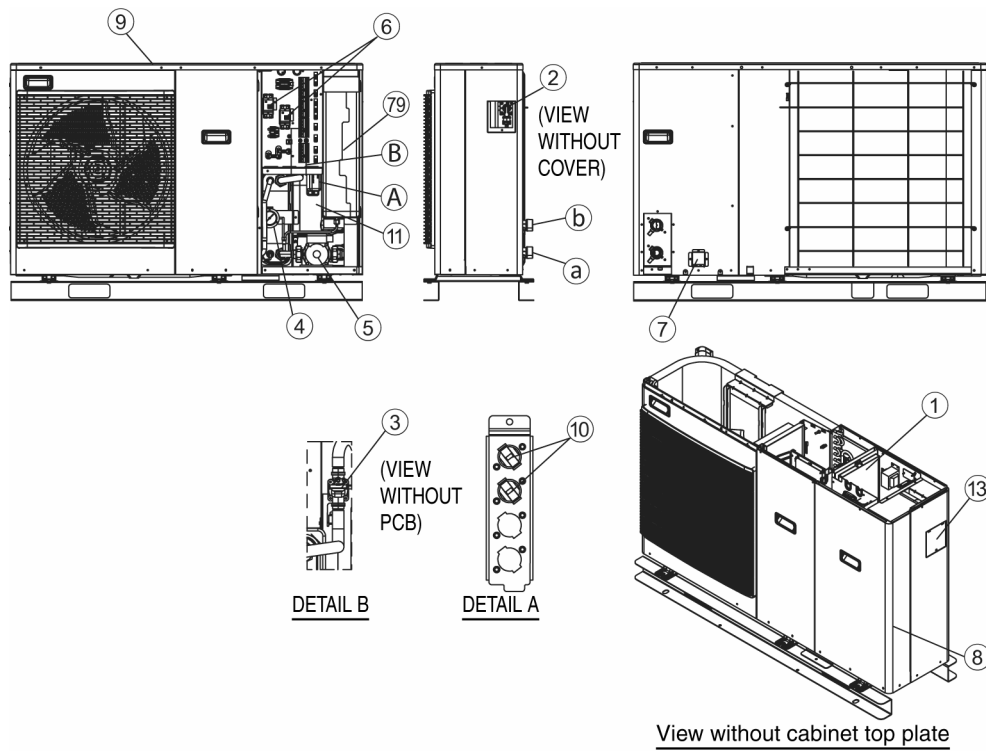

Component name

- ① PCB
- ② Pressure relief valve
- ③ Flow switch
- ④ Pressure gauge
- ⑤ Water pump
- ⑥ RCCB
- ⑦ Cable cover
- ⑧ Cabinet front plate
- ⑨ Cabinet top plate
- ⑩ Overload protector
- ⑪ Heater assembly
- ⑫ Expansion vessel
- ⑬ Cover

Connector name

- Ⓐ Water inlet
- Ⓑ Water outlet

It is advisable to avoid more than 2 blockage directions. For better ventilation & multiple-outdoor installation, please consult authorized dealer/specialist.

11.1 Select the Best Location

- Install Mono bloc unit at outdoor only.
- Avoid location where ambient temperature is below -20°C .
- Must install on a flat horizontal and solid hard surface.
- A place where should not be any heat source or steam near the Mono bloc unit.
- A place where air circulation is good.
- A place where drainage can be easily done.
- A place where Mono bloc unit's operation noise will not cause discomfort to the user.
- A place where accessible for maintenance.
- Ensure to keep minimum distance of spaces as illustrated below from wall, ceiling, or other obstacles.
- A place where flammable gas leaking might not occur.
- A place where the Mono bloc unit's piping and wiring lengths come within reasonable ranges.
- If an awning is built over the unit to prevent direct sunlight or rain, be careful that heat radiation from the condenser is not obstructed.
- Do not place any obstacles which may cause a short circuit of the discharged air.
- Avoid install the Mono bloc unit at a location where suction side may be exposed directly to wind.
- If Mono bloc unit installed near sea, region with high content of sulphur or oily location (e.g. machinery oil, etc.), its lifespan may be shortened.
- When installing the product in a place where it will be affected by typhoon or strong wind such as wind blowing between buildings, including the rooftop of a building and a place where there is no building in surroundings, fix the product with an overturn prevention wire, etc. (Overturn prevention fitting model number: K-KYZP15C)
- When connecting solar pump station cable between Mono bloc unit and solar pump station, the distance between both apparatuses shall be 2 ~ 8 meters and the length of the said cable must be shorter than 10 meter.
Fail to do so may lead to abnormal operation to the system.



11.2 Mono Bloc Unit Installation

Mono bloc unit will become heavy when filled with water. Therefore, please install the Mono bloc unit on strong concrete floor, by considering weight of unit and water.

- Fix Mono bloc unit on the concrete floor with M12 anchor bolt at 4 locations.
- Pull-out strength of these anchor bolts must be above 15000N.

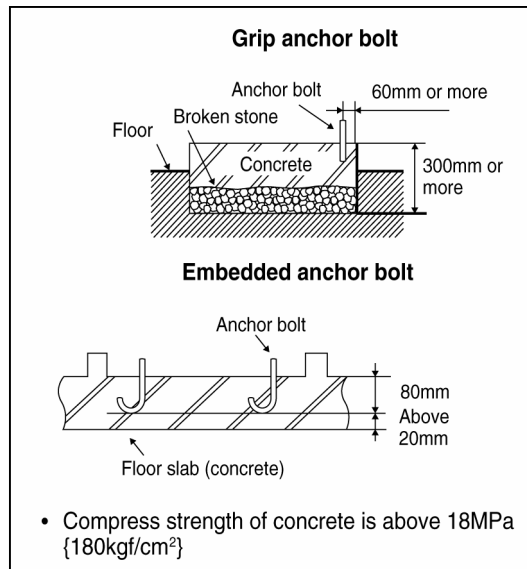

Illustration of grip type and embedded type anchor bolt

11.3 Piping Installation

⚠ WARNING

This section is for authorized and licensed electrician / water system installer only. Work behind the front plate secured by screws must only be carried out under supervision of qualified contractor, installation engineer or service person.

Please engage a licensed water circuit installer to install this water circuit.

- The minimum requirement of water in the system is 30 litres. If this value could not be achieved, please install additional buffer tank (field supply).
- This water circuit must comply with relevant European and national regulations (including EN61770), and local building regulation codes.
- Ensure the components installed in the water circuit could withstand water pressure during operation.
- Do not apply excessive force to piping that may damage the pipes.
- Use Rp 1 1/4" nut for both water inlet and water outlet connection and clean all piping with tap water before install.
- Cover the pipe end to prevent dirt and dust when inserting it through a wall.
- If existing tank is to be connected to this Mono bloc unit, ensure the pipes are clean before water pipe installation is carried out.
- Must install external filter (30 mesh or more, field supply) before water inlet of Mono bloc unit (with "WATER IN" indication).
- Refer to Diagram 3.1 for pipe connection of Panel Heater, Floor Heater, Tank Unit, Solar Pump Station, 3-way Valve Kit and etc. Fail to connect the pipes appropriately might cause the unit malfunction.

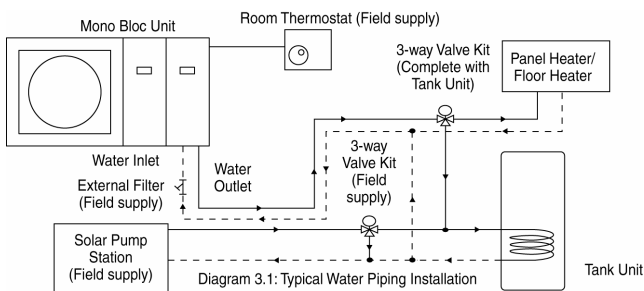

- Choose proper sealer which can withstand the pressures and temperatures of the system.
- Make sure to use two spanners to tighten the connection. Further tighten the nuts with torque wrench in specified torque as stated in the table.

Model	Nut size (Torque)
	Water
WH-MD*06*3E5	Rp 1 1/4" [117.6 N•m]
WH-MD*09*3E5	

- If non-brass metallic piping is used for installation, make sure to insulate the piping to prevent galvanic corrosion.
- Do not use pipes that are crushed or deformed. If these inferior pipes are used, it may cause unit malfunction.
- Make sure to insulate the water circuit piping (insulator thickness: 20mm or more) to prevent reduction of heating capacity, as well as avoid freezing of the outdoor water circuit piping during winter season.
- After installation, check the water leakage condition in connection area during test run.
- After test run, please clean the external filter. Reinstall it after finish cleaning.
- In case of a power supply failure or pump operating failure, drain the system (as suggested in the figure below).

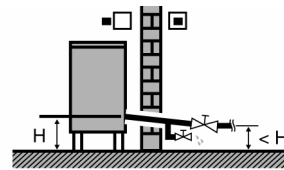

When water is idle inside the system, freezing up is very likely to happen which could damage the system.

Drainage piping installation

- Use a drain hose with inner diameter of 15 mm.
- The hose must be installed in a continuously downward direction and left open to the frost-free atmosphere.
- If drain hose is long, use a metal support fixture along the way to eliminate the wavy pattern of drain tube.
- The water may drip from this drain hose. Therefore must guide the hose without close or block the outlet of the hose.
- Do not insert this hose into sewage hose or cleaning hose that may generate ammonia gas, sulfuric gas, etc.
- If necessary, use a hose clamp to tighten the hose at drain hose connector to prevent it from leaking.

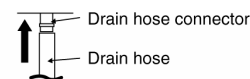
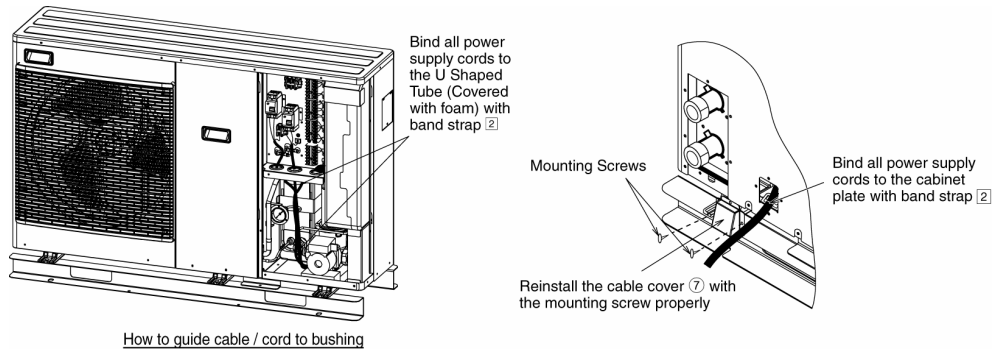
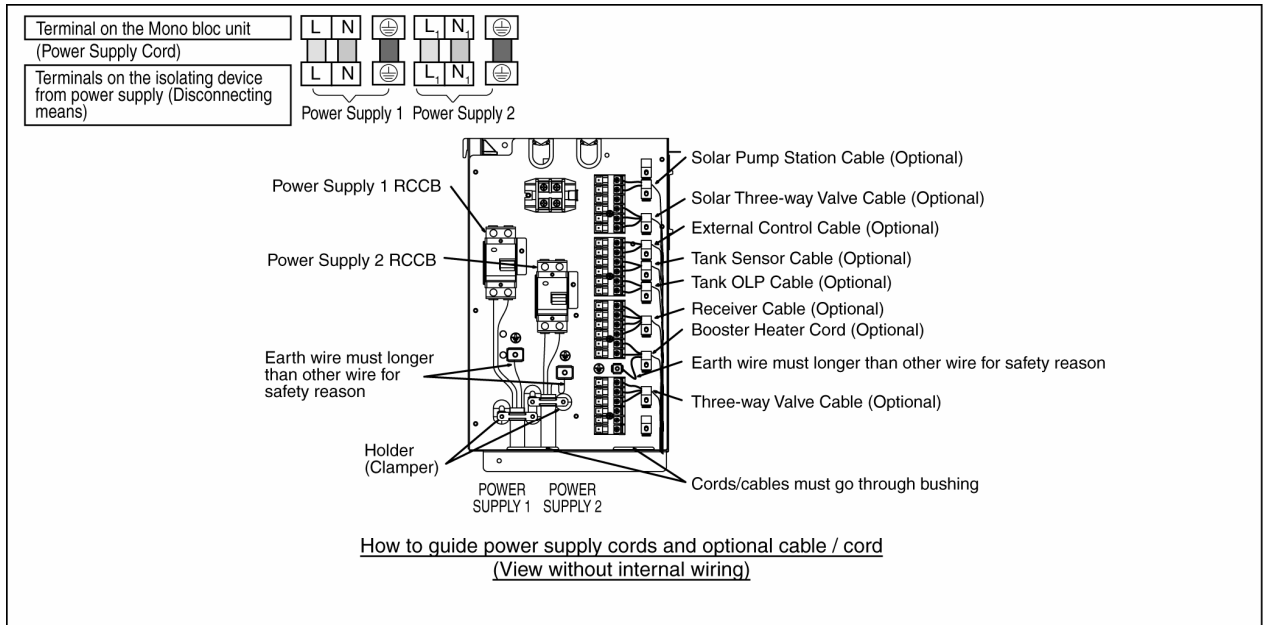

Illustration of how to fix drain hose to Mono bloc unit

11.4 Connect The Cord And Cable To Mono Bloc Unit

(REFER TO WIRING DIAGRAM AT UNIT FOR DETAIL)

- 1 Cable connection to the power supply through isolating device (Disconnecting means).
 - Isolating device (Disconnecting means) should have minimum 3.0 mm contact gap.
 - Connect the approved polychloroprene sheathed power supply 1 cord (3 x 4.0 or 6.0 mm²) and power supply 2 cord (3 x 4.0 mm²), type designation 60245 IEC 57 or heavier cord to the RCCB, and to the other end of the cord to isolating device (Disconnecting means).
- 2 To avoid cable and cord harmed by sharp edge, cable and cord must go through cable cover (located at the rear side of Mono bloc unit) before carry out electrical connection. The cable cover ⑦ must be used and must not take off.
- 3 Secure the cable onto the control board with the holder (clamper).



Connecting with external device (optional)

- 1 All connections shall follow to the local national wiring standard.
- 2 It is strongly recommended to use manufacturer-recommended parts and accessories for installation.
- 3 Maximum output power of booster heater shall be ≤ 3 kW. Booster Heater cord must be (3 x min 1.5 mm²), of type designation 60245 IEC 57 or heavier.
- 4 Three-way Valve shall be spring and electronic type. Valve cable shall be (3 x min 0.5 mm²), of type designation 60245 IEC 57 or heavier, or similarly double insulation sheathed cable.
 - * note: - Shall be CE marking compliance component.
 - It shall be directed to heating mode when it is OFF.
 - Maximum load for the valve is 3VA.
- 5 Receiver shall be connected to "Room Thermostat", refer to "Field Supply Accessories" table for details. Receiver cable must be (4 or 3 x min 0.5 mm²), double insulation layer of PVC-sheathed or polychloroprene sheathed cable. (connection refer to Diagram 4.2).
- 6 Tank OLP cable must be (2 x min 0.5 mm²), double insulation layer of PVC-sheathed or polychloroprene sheathed cable.
 - * note: if such connection deemed NO necessary for tank OLP, please connect jumper between terminal no. 13 and 14.

- 7 Tank Sensor shall be resistance type, please refer to Graph 4.1 for the characteristic and details of sensor. Its cable shall be (2 x min 0.3 mm²), double insulation layer (with insulation strength of min 30V) of PVC-sheathed or polychloroprene sheathed cable.
- 8 External Controller shall be connected to 1-pole switch with min 3.0mm contact gap. (connection refer to Diagram 4.3). Its cable must be (2 x min 0.5 mm²), double insulation layer of PVC-sheathed or polychloroprene sheathed cable.
 - * note: - When making such connection, kindly remove the jumper between terminal no. 17 and 18.
 - Switch used shall be CE compliance component.
 - Maximum operating current shall be less than 3A_{rms}.
- 9 Solar Three-way Valve cable shall be (3 x min 0.5 mm²), double insulation layer PVC-sheathed or polychloroprene sheathed cable.
- 10 Must install Solar Connection PCB (optional) to Mono bloc unit when Solar Pump Station is utilized. Refer Solar Connection PCB installation instruction for detail of installation.
- 11 Solar Pump Station cable shall be (2 x min 0.5 mm²), of double insulation PVC-sheathed or polychloroprene sheathed cable. Strongly recommended install with maximum length of 10 meter only.

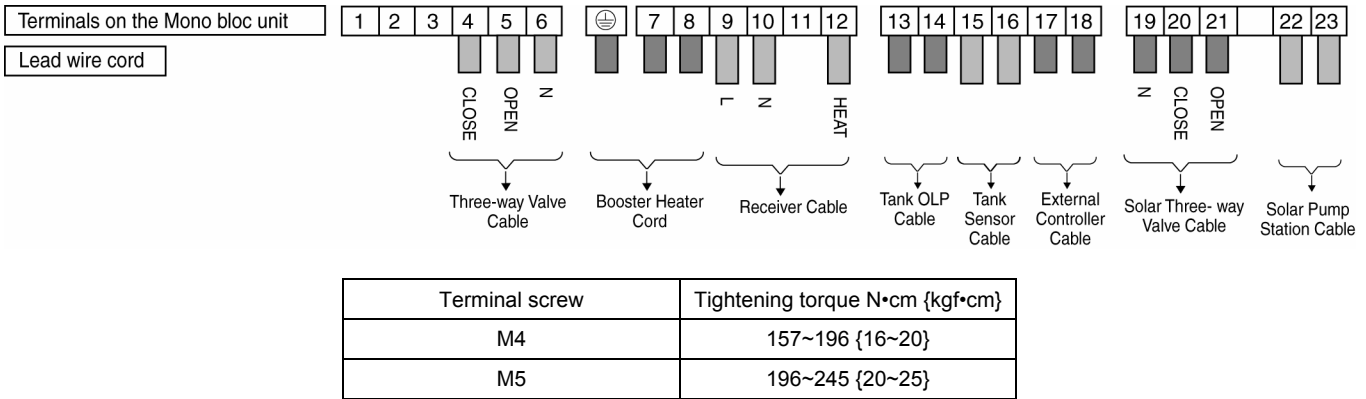

11.4.1 Wire Stripping And Connecting Requirement

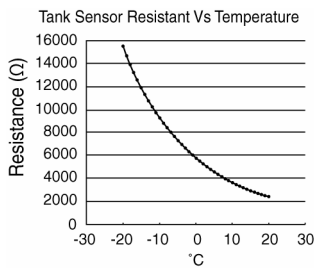
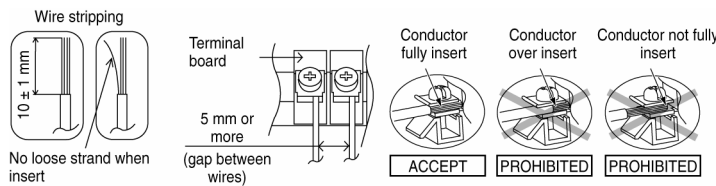

Graph 4.1: Tank sensor characteristic

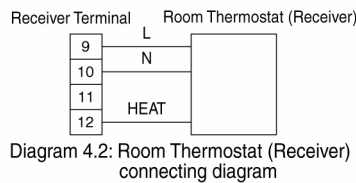

Diagram 4.2: Room Thermostat (Receiver) connecting diagram

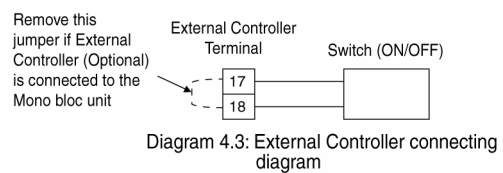

Diagram 4.3: External Controller connecting diagram

11.4.2 Connecting Requirement

- The equipment's power supply 1 complies with IEC/EN 61000-3-12 provided that the short-circuit power S_{sc} is greater than or equal to 1001.24kW at the interface point between the user's supply and the public system. It is the responsibility of the installer or user of the equipment to ensure, by consultation with the distribution network operator if necessary, that the equipment is connected only to a supply with a short-circuit power S_{sc} greater than or equal to 1001.24kW.
- The equipment's power supply 1 shall be connected to a suitable supply network, having service current capacity $\geq 100A$ per phase. Please liaise with supply authority to ensure that the service current capacity at the interface point is sufficient for the installation of the equipment.
- The equipment's power supply 2 complies with IEC/EN 61000-3-12.
- The equipment's power supply 2 shall be connected to a suitable supply network, with the following maximum permissible system impedance Z_{max} at the interface for models: 0.236Ω. Please liaise with supply authority to ensure that the power supply 2 is connected only to a supply of that impedance or less.

11.4.3 Wired Remote Controller Installation

⚠ WARNING	
⊘	Do not modify the length of the remote controller cable. Otherwise, it will cause fire or electrical shock.
!	Be sure to turn off the main power before installing and connecting the remote controller. Otherwise, it will cause the electrical shock.
!	Use the attached accessories parts and specified parts for installation. Otherwise, it will cause the set to fall, fire or electrical shock.
!	If passing the remote controller cable through a wall, be sure to install a water trap above the cable. Otherwise, it will cause the electrical shock.
⚠ CAUTION	
!	Install in a flat surface to avoid warping of remote controller, else damage to the LCD case or operation problems may result.
!	Avoid installing the remote controller cable near refrigerant pipes or water pipes, else will cause electrical shock or fire.
!	Install the remote controller cable at least 5cm away from electric wires of other appliances to avoid miss operation (electromagnetic noise).
!	Be sure to use only the accessory screws to avoid damage of remote controller PCB.

11.4.3.1 Selecting The Installation Location

- Allow sufficient space around the remote controller (1) as shown in the illustration above.
- Install in a place which is away from direct sunlight and high humidity.
- Install in a flat surface to avoid warping of the remote controller. If installed to a wall with an uneven surface, damage to the LCD case or operation problems may result.
- Install in a place where the LCD can be easily seen for operation. (Standard height from the floor is 1.2 to 1.5 meters.)
- Avoid installing the remote controller cable near refrigerant pipes or drain pipes, else it will cause electrical shock or fire.

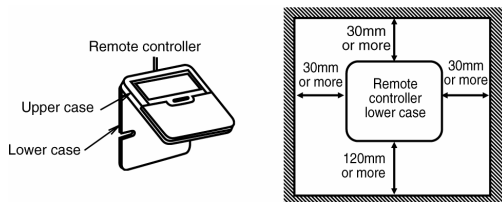
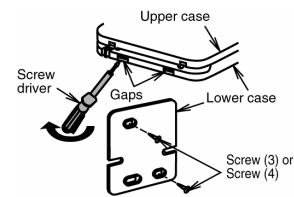

A. If Remote Controller Cable Is Embedded

- 1 Embed an outlet box (JIS C 8336) into the wall. Outlet box may be purchased separately. Medium-sized square outlet box (obtain locally) Part No. DS3744 (Panasonic Co., Ltd.) or equivalent.
- 2 Secure the remote controller lower case to the outlet box with the two accessory screws (3). Make sure that the lower case is flat against the wall at this time, with no bending.
- 3 Pass the remote controller cable (2) into the box.
- 4 Route the remote controller cable (2) inside the lower case through rear feeding-out direction.
- 5 Insert firmly the connector of remote controller cable (2) to connector (CON1) in the upper case circuit board.
[Refer to the illustration at below.]
- 6 Secure the remote controller upper case to the lower case with the tabs provided.

11.4.3.2 Installing The Remote Controller Unit To The Wall

- 1 Remove the remote controller (1) lower case. (Insert a flat-tipped screw driver or similar tool 2 to 3 mm into one of the gaps at the bottom of the case, and twist to open. Refer to the illustration at right.)
Be careful not to damage the lower case.
- 2 Do not remove the protective tape which is affixed to the upper case circuit board when remove the remote controller lower case.
- 3 Secure the lower case to an outlet box or wall. Refer to (A) or (B) instructions below depending on your choice of cable installation.
- 4 Be sure to use only the screws provided.
- 5 Do not over tighten the screws, as it may result in damage to the lower case.

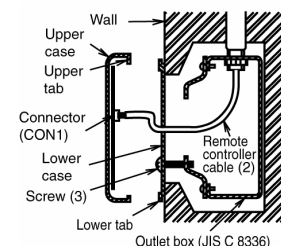

⚠ CAUTION

When the wall is hollow, please be sure to use the sleeve for remote controller to prevent dangers caused by mice biting the cable.

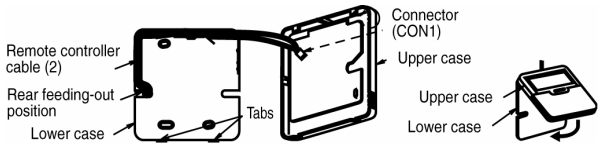

B. If Remote Controller Cable Is Exposed

- 1 Install the remote controller lower case to the wall with the two accessory screws (4).
- 2 Fasten the screws properly until screw head is lower than the rib and reach the base of remote controller lower case to ensure they do not damage the PCB inside the remote controller (1).

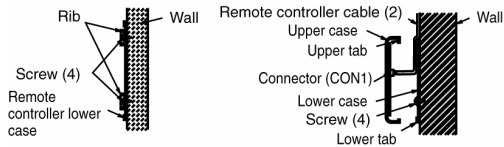

- 3 The feeding-out direction for the remote controller cable can be either via top, left or right side.
- 4 Use nipper to cut a notch at the upper case. (Select the intended feeding-out position)
- 5 Route the remote controller cable (2) inside the lower case in accordance with the intended feeding-out direction. (Refer to the illustration at below)
- 6 Insert firmly the connector of remote controller cable (2) to connector (CON1) in the upper case circuit board. (Refer to the illustration at below)
- 7 Secure the remote controller upper case to the lower case with the tabs provided.

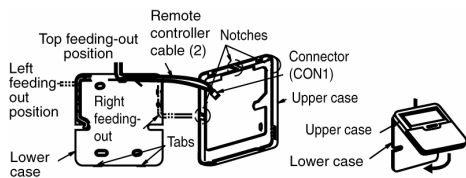

11.4.3.3 Connecting The Remote Controller's Cable To Mono Bloc Unit

CAUTION

Be sure to turn off the main power before installing and connecting the remote controller. Otherwise, it will cause the electrical shock.

- 1 Remove the cabinet front plate.
- 2 Connect the remote controller's cable with the provided connector as shown in below illustration. (Refer wiring diagram for detail.)
- 3 Guide the remote controller cable through the clammer, bushing and Cable cover (7). (Refer illustration "How to connect Remote Controller to Provided Connector" for detail.)
- 4 Reinstall the cabinet front plate after connection complete.

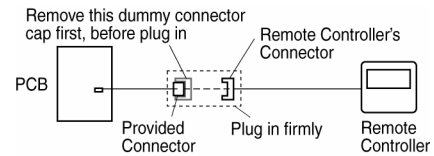

Connect the wired remote controller's cable with the connector provided here

Clamp the wired remote controller's cable with clammer.

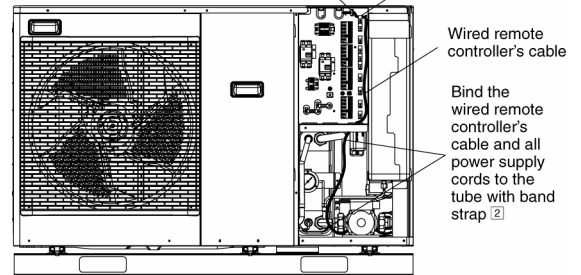

How to connect Remote Controller to Provided Connector

11.4.3.4 Disposal of Mono Bloc Unit Drain Water

- When a Drain elbow (1) is used, please ensure to follow below:
 - The unit should be placed on a stand which is taller than 50mm.
 - Cover the 8 holes (ø20mm) with Rubber cap (4) (refer to illustration below)

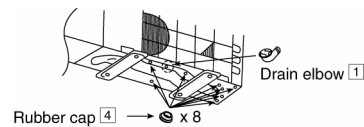

- If the unit is used in an area where temperature falls below 0°C for 2 or 3 consecutive days, it is recommended not to use the Drain elbow (1) and Rubber cap (4), for the drain water freezes and the fan will not rotate.

12. Operation and Control

12.1 Basic Function

Inverter control, which equipped with a microcomputer in determining the most suitable operating mode as time passes, automatically adjusts output power for maximum comfort always. In order to achieve the suitable operating mode, the microcomputer maintains the set temperature by measuring the temperature of the environment and performing temperature shifting. The compressor at monobloc unit is operating following the frequency instructed by the microcomputer at monobloc unit that judging the condition according to internal water setting temperature and water outlet temperature.

12.1.1 Heating Operation

12.1.1.1 Thermostat control

- Compressor is OFF when Water Outlet Temperature - Internal Water Setting Temperature > 2°C for continuously 3 minutes.
- Compressor is ON after waiting for 3 minutes, if the Water Outlet Temperature - Water Inlet Temperature (temperature at thermostat OFF is triggered) < -3°C.

12.1.2 Tank Mode Operation

Control contents:

- 3 ways valve direction
 - 3 ways valve switch and fix to tank side.
- Heat Pump Thermostat characteristic
 - Water set temperature = tank set temperature or **[55°C]** whichever lower.
 - Heat Pump Water Outlet set temperature is set to Maximum (53°C) at tank mode
- i. Case 1
 - THERMO OFF TEMP:
 - 1 THERMO OFF TEMP = Water set temperature + **[+2°C]**.
 - 2 Tank temperature > THERMO OFF TEMP for continuous 3 minutes, heat pump OFF and water pump OFF.
 - THERMO ON TEMP:
 - 1 THERMO ON TEMP = Water set temperature + **[-3°C]**.
 - 2 When detect tank temperature < THERMO ON TEMP, water pump ON for 3 minutes then heat pump ON.
 - Pump ON when Tank temperature is less than Tank temperature when Heat pump Thermo Off - **[-3°C]**.
- ii. Case 2
 - Heat pump THERMO OFF TEMP:
 - 1 Heat pump THERMO OFF TEMP = 55°C + **[+2°C]**.
 - 2 Water outlet temperature > Heat pump THERMO OFF TEMP for continuous 3 minutes, heat pump OFF but water pump ON.
 - Heat pump THERMO ON TEMP:
 - 1 Heat pump THERMO ON TEMP = Water inlet during thermo off time + **[-3°C]**.
 - 2 Heat pump ON back when water outlet temperature < Heat pump THERMO ON TEMP.
- iii. Case 3
 - Heat pump THERMO OFF TEMP:
 - 1 Water inlet temperature > 55°C for continuous 60 secs, heat pump OFF and water pump OFF.
 - Heat pump THERMO ON TEMP:
 - 1 Heat pump THERMO ON TEMP = Water inlet during thermo off time + **[-3°C]**.
 - 2 Water pump ON back when tank temp. < tank temp. when heat pump thermo off + **[-3°C]**.
 - 3 Heat pump only ON back after water outlet temperature < Heat pump THERMO ON TEMP & water pump ON for 3 minutes.

- Booster heater control
 - Booster heater turn On and Off follow normal operation.
 - Booster heater turn ON condition:
 - 1 During startup time (initialization), Booster heater turn ON after DELAY TIMER.
 - 2 When tank temperature lower than HEATER ON TEMP.
 - 3 **[20]** minutes from previous heater off.
 - Booster heater turn OFF condition:
 - 1 When tank temperature higher than tank set temperature for continuous 15 secs.
- Solar 3 way valve
 - Solar pump operates follow solar operation specification.
- Others
 - Indoor backup heater cannot be ON during tank mode only.

12.1.3 Heat + Tank Mode Operation

Setting 1: When Heating priority is set by control panel:

- 1 3 ways valve control:
 - 3 ways valve switch to room side during External Room Thermo ON **OR** Solar 3ways valve ON **OR** Tank Thermo OFF time, and switch to tank side at External Room Thermo OFF **AND** Solar 3 ways valve OFF
- 2 Heat pump operation control:-
 - **During External Room Thermo ON time:** (When room thermo ON, heat pump must operate to room side)
 - Heat pump operate follow normal operation at room side
 - **During External Room Thermo OFF time:**
 - Switch 3 ways valve to tank side, IF
 - Under Solar Priority Set condition:
 - Tank temperature < Tank THERMO ON TEMP **AND** Solar Valve OFF
 - Under Solar Priority Not Set condition:
 - Tank temperature < Tank THERMO ON TEMP
 - Switch back 3 ways valve to room side, Heat pump and water pump turn OFF, IF
 - External Room Thermo ON back **OR**
 - Under Solar Priority Set condition:
 - Tank temperature > Tank THERMO OFF TEMP. for continuous 3 minutes **OR** Solar Valve ON
 - Under Solar Priority Not Set condition:
 - Tank temperature > Tank THERMO OFF TEMP for continuous 3 minutes

* THERMO ON and THERMO OFF point refer to case below.

Operation condition when 3 ways valve switch to tank side:

- Heat pump tank target temperature = tank set temperature or [55°C] whichever lower
- Heat Pump Water Outlet set temperature is set to [53°C] during tank interval
- Initial Tank THERMO ON TEMP = heat pump tank target temperature + **[-3°C]**

Case 1:

- THERMO OFF TEMP:
 1. THERMO OFF TEMP = Heat pump tank target temperature + **[+2°C]**.
 2. Tank temperature > THERMO OFF TEMP for continuous 3 minutes, switch 3 ways valve to room side.
- Next THERMO ON TEMP:
 1. THERMO ON TEMP = Heat pump tank target temperature + **[-3°C]**.
 2. If tank temperature < THERMO ON TEMP **AND** External Room Thermo OFF, switch to tank side.

Case 2:

- Heat pump THERMO OFF TEMP:
 1. Heat pump THERMO OFF TEMP = 53°C + **[+4°C]**.
 2. Water outlet temperature > Heat pump THERMO OFF TEMP for continuous 3 minutes, switch 3 ways valve to room side.
- Next THERMO ON TEMP:
 1. THERMO ON TEMP = Tank temp. when heat pump thermo off + **[-3°C]**.
 2. If tank temperature < THERMO ON TEMP **AND** External Room Thermo OFF, switch to tank side.

Case 3:

- Heat pump THERMO OFF TEMP:
 1. Water inlet temperature > 55°C for continuous 60 secs, switch 3 ways valve to room side.
- Next THERMO ON TEMP:
 1. THERMO ON TEMP = Tank temp. when heat pump thermo off + **[-3°C]**.
 2. If tank temperature < THERMO ON TEMP **AND** External Room Thermo OFF, switch to tank side.

Case 4: (Only during solar priority is set condition)

- When solar request ON, solar valve will ON and switch 3 ways valve to room side
 - THERMO ON TEMP:
 1. THERMO ON TEMP = Heat pump tank target temperature + **[-3°C]**.
 2. If tank temperature < THERMO ON TEMP **AND** External Room Thermo OFF **AND** Solar 3WV OFF, switch to tank side.
- 3 Backup Heater control:-
- During External Room Thermo ON time, follow normal backup heater control operation
 - During External Room Thermo OFF time, Backup heater OFF
- 4 Booster heater control:
- Booster heater On/Off follow normal operation.
- * Under solar priority is set condition, when solar 3 way valve is ON, booster heater turn OFF.
- 5 Solar 3 way valve:
- Solar 3 way valve operates follow solar operation specification.
- * Under solar priority is set condition, when solar 3WV turn ON, booster heater will turn OFF and 3 ways valve switch to room side.
- * Under solar priority is not set condition, solar 3WV will OFF when heat pump operate to tank side.

Setting 2: When heating priority is not set by control panel:

- When Solar Priority is set / not set by control panel:
 - 1 3 ways valve control:
 - 3 ways valve switch to room side during heating heat-up interval, and switch to tank side during tank heat-up interval. Both mode will switch alternatively. Tank mode is the Initial running mode of this heat + tank mode (heating no priority).
 - 2 Heat pump operation control:
 - During heating heat-up interval
 - Follow normal heating operation.
 - Under solar priority set condition:
 - Switch to tank heat-up interval and start counting tank heat-up timer when External Room Thermo OFF **AND** solar 3WV OFF **AND** Tank temperature < THERMO ON TEMP (End Room Interval Early) **OR**
 - Switch to tank heat-up interval and start counting tank heat-up timer when tank temperature < THERMO ON TEMP **AND** solar 3WV OFF after room heat-up timer complete

Under solar priority not set condition:

- Switch to tank heat-up interval and start counting tank heat-up timer when External Room Thermo OFF **AND** Tank temperature < THERMO ON TEMP (End Room Interval Early) **OR**
- Switch to tank heat-up interval and start counting tank heat-up timer when tank temperature < THERMO ON TEMP after room heat-up interval timer complete

* THERMO ON TEMP is defined form following Case1 to Case 4.

- o During tank heat-up interval
 - Heat pump tank target temperature = Tank set temperature or [55°C] whichever lower
 - Heat pump Water Outlet set temperature is set to Maximum [53°C] during tank interval
 - Initial Tank THERMO ON TEMP = heat pump tank target temperature + [-3°C]

Case 1:

- THERMO OFF TEMP:

1. THERMO OFF TEMP = Heat pump tank target temperature + [+2°C].
2. Tank temperature > THERMO OFF TEMP for continuous 3 minutes, switch 3 ways valve to room side. End Tank heat-up interval and start count heating heat-up interval.

- THERMO ON TEMP:

1. THERMO ON TEMP = Heat pump tank target temperature + [-3°C].
2. After Heating heat-up interval, always detect tank temperature. Switch to next tank heat-up interval when tank temperature < THERMO ON TEMP

Case 2:

- Heat pump THERMO OFF TEMP:

1. Heat pump THERMO OFF TEMP = 53°C + [+4°C].

a. Water outlet temperature > Heat pump THERMO OFF TEMP for continuous 90 seconds, switch 3 ways valve to room side. End Tank heat-up interval and start count heating heat-up interval.

- THERMO ON TEMP:

1. THERMO ON TEMP = Tank temp. when heat pump thermo off + [-3°C].
2. After Heating heat-up interval, always detect tank temperature. Switch to next tank heat-up interval when tank temperature < THERMO ON TEMP

Case 3:

- Heat pump THERMO OFF TEMP:

1. Water inlet temperature > 55°C for continuous 60 secs, switch 3 ways valve to room side. End tank heat-up interval and start count heating heat-up interval.

- THERMO ON TEMP:

1. THERMO ON TEMP = Tank temp. when heat pump thermo off + [-3°C].
2. After Heating heat-up interval, always detect tank temperature. Switch to next tank heat-up interval when tank temperature < THERMO ON TEMP

Case 4 (Only during solar priority is set condition):

- When solar pump ON, tank heat-up interval end early and 3 ways valve switch to room side.

- THERMO ON TEMP:

1. THERMO ON TEMP = Heat pump tank target temperature + [-3°C].
2. After Heating heat-up interval, always detect tank temperature. Switch to next tank heat-up interval when tank temperature < THERMO ON TEMP and solar 3 way valve OFF.

- Tank interval will end and start heating interval timer, IF

1. Tank interval timer finish AND External Room Thermo ON **OR**
2. Fulfill above 4 case of thermo off condition.

3 Backup heater control:

- o During heating heat up interval.
 - Follow normal backup heater control operation.
- o During tank heat-up interval.
 - Backup heater OFF during this interval.

- 4 Booster heater control:
 - During heating heat-up interval.
 - Booster heater ON/OFF according to booster heater operation control.
 - During tank heat-up interval.
 - Once switch from heating heat-up interval to tank heat-up interval, turn off the booster heater and start counting the BOOSTER HEATER DELAY TIMER.
 - Booster heater turn ON after BOOSTER HEATER DELAY TIMER fulfill and tank temperature lower than tank set temperature.
 - BOOSTER HEATER DELAY TIMER is clear when switch to heating heat-up interval.
 - 5 Solar 3 way valve:
 - Solar 3WV operates follow solar operation specification.
- * Under solar priority is set condition, when solar 3WV is ON, booster heater turn OFF
 * Under solar priority is not set condition, solar 3WV only can ON during heating heat-up interval.

12.1.4 Setting Water Outlet Temperature For Heat Mode

- The set temperature define the parameters for the outdoor ambient temperature dependent operation of the unit. Where by the internal water setting temperature is determined automatically depending on the outdoor temperature. The colder outdoor temperatures will result in warmer water and vice versa. The user has the possibility to shift up or down the target water temperature by remote control setting.

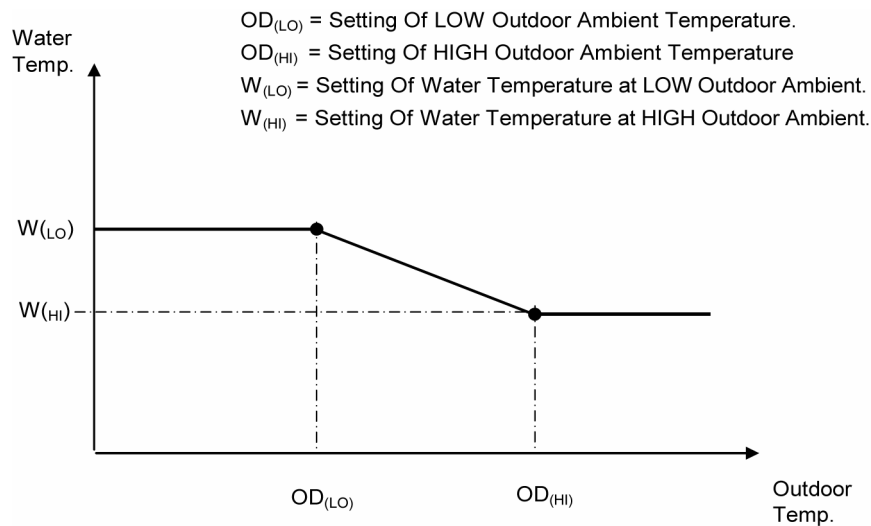

- Outdoor temperature is updated every 30 minutes when operation ON.

12.1.4.1 Heating Mode Operation Time Chart

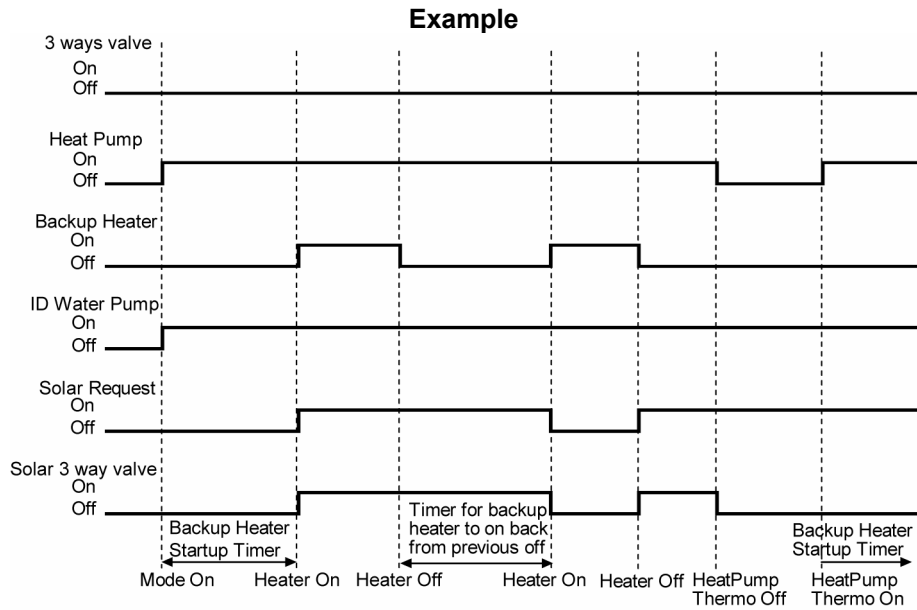

- 1 3 ways valve control:
 - 3 ways valve switch and fix to heating side
- 2 Heat pump operate follow normal heating operation.
- 3 Backup heater operate follow normal operation.
- 4 Solar 3 way valve operates follow solar operation specification.

12.1.5 Water Temperature Thermo Shift Setting

- Switches are ignored during "PUMPDW" = ON.
- Switches are ignored during "STATUS" = ON.
- "▲", "▼", "SELECT" switch are ignored if "SETTING" = OFF.
- "CANCEL" switch is ignored if "SETTING" = OFF & "STATUS" = OFF.
- If "SET" Switch pressed for less than 5secs, immediately enter water temperature shift setting mode.
- Once enter this setting mode, "SETTING" display is ON.
This setting mode is used to easily shift the target water outlet temperature.

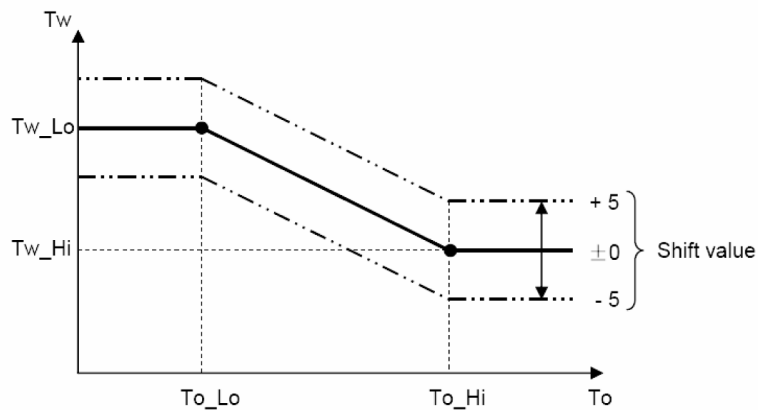

T_w : Setting water temperature
 T_o : Outdoor temperature
 Shift value : Setting water temperature thermo shift

T_{w_Lo} : Setting water temperature at low outdoor temperature (T_{o_Lo}).
 T_{w_Hi} : Setting water temperature at high outdoor temperature (T_{o_Hi}).

12.1.6 Fan Motor Operation

Fan motor is adjusted according to operation condition. It starts when compressor starts operation and it stops 30 seconds after compressor stops operation.

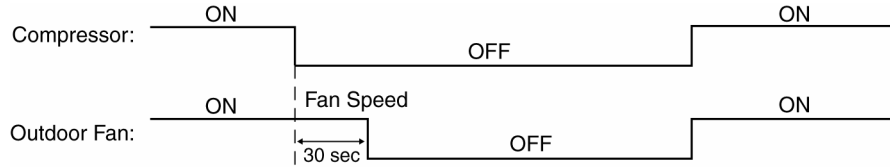

12.2 Water Pump

12.2.1 Water Pump Control

- Once the monobloc unit is ON, the water pump will be ON immediately and no error judgement for 9 minutes. However, during this 9 minutes operation, if there is any abnormality cause at monobloc unit or malfunction, the compressor should be OFF immediately and restart delay after 3 minutes.
- The system will start checking on the water flow level after operation start for 9 minutes. If water flow level is detected low continuously for 10 secs, the water pump and compressor will be OFF permanently and OFF/ON remote control LED will blink (H62 error occurs).
- The water pump will remain ON when compressor OFF due to thermostat OFF.

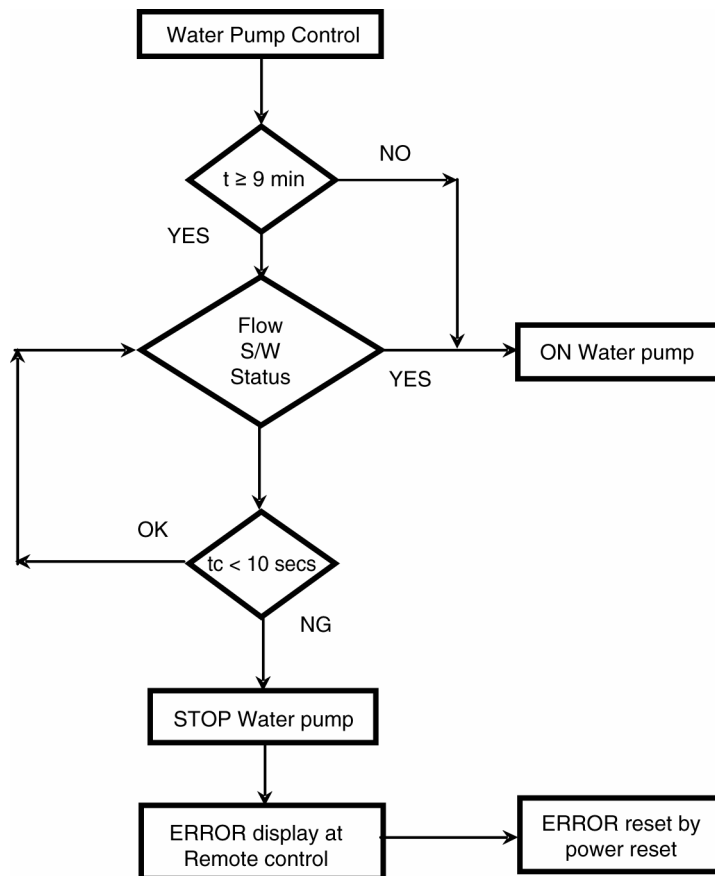

12.3 Pump Down Operation

Purpose

Ensure the pump down operation when relocating or disposing of the unit. The pump down operation will extract all refrigerant from the piping into the monobloc unit.

- Make sure the OFF/ON remote control LED is OFF (no operation).
- Press the Pump Down button to start the pump down operation.
- No low pressure protection error during pump down operation and 3-way valve will be shift to heating side.
- Press OFF/ON button to stop the pump down operation.

12.4 Flow Switch

12.4.1 Flow Switch Control

- 1 The water flow switch serve as an overload protector that shuts down the unit when the water level is detected to be low.
- 2 Detection is Lo (0V) when there is no water flow, and detection is Hi (5V) when there is water flow.

12.5 Force Heater Mode Operation

The backup heater also serves as backup in case of malfunctioning of the monobloc unit.

- 1 Make sure the OFF/ON remote control LED is OFF (no operation).
- 2 Press the Force button to start the force heater mode operation.
- 3 During force heater mode, all other operations are not allowed.
- 4 Press OFF/ON button to stop the force heater mode operation.

12.6 Monobloc Unit Safety

12.6.1 Monobloc Unit Safety Control

- 1 When water pump is ON, the system will start checking flow switch status (ON/OFF).
- 2 If the flow switch ON for 10 seconds, the system will check on the water inlet temperature for 10 seconds. If the water inlet temperature not exceeds 80°C, the water pump shall be continuously running with normal mode. If the water inlet temperature exceeds 80°C for continuously 10 seconds, the water pump will be OFF immediately.
- 3 After water pump OFF for more than 10 minutes, it will be ON back and the monobloc unit safety control checking is restarted.

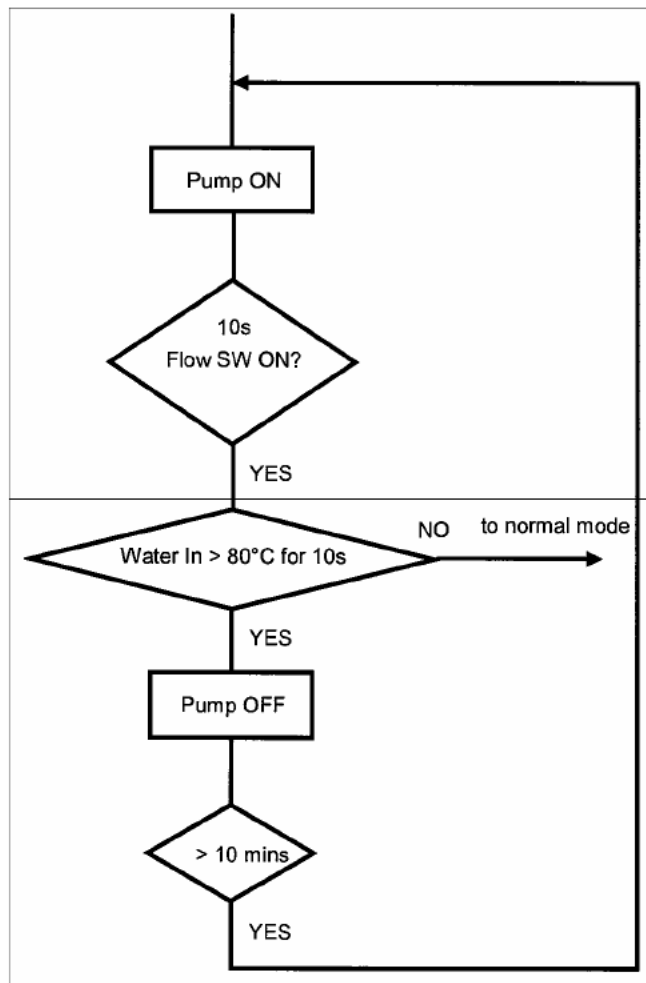

12.7 Auto Restart Control

When the power supply is cut off during the operation of Monobloc unit, the compressor will re-operate after power supply resumes.

12.8 Indication Panel

LED	Operation
Color	Green
Light ON	Operation ON
Light OFF	Operation OFF

Note:

- If Operation LED is blinking, there is an abnormality operation occurs.

12.9 Back-Up Heater Control

12.9.1 Electric Heater control

- 1 Normal Heating Mode
 - Heater On condition:
 - a. Heater switch is ON
 - b. After Heatpump thermo ON for **[30]** mins
 - c. After water pump operate **[9]** mins
 - d. Outdoor air temperature < Outdoor set temperature for heater
 - e. When water outlet temperature < Water set temperature + **[-8°C]**
 - f. **[20]** minutes since previous Backup heater Off
 - * When heatpump cannot operate due to error happens during normal operation, heater will go into force mode automatic
 - * Heater need to operate during deice operation
 - Heater Stop Condition:
 - a. When outdoor set temperature > outdoor set temperature + **[+2°C]** for continuous 15 secs OR
 - b. When water out temp > water set temperature + **[-2°C]** for continuous 15 secs OR
 - c. Heater switch is Off OR
 - d. Heat pump thermo-off or OFF condition
 - 2 Force Heater Mode
 - Heater On Condition:
 - a. After water pump operate **[9]** mins
 - b. When water outlet temperature < water set temperature + **[-8°C]**
 - c. **[20]** minutes since previous Backup heater Off
 - Heater Stop condition
 - a. Force mode off **OR**
 - b. When water outlet temperature > water set temperature + **[-2°C]** for continuous 15 secs
- * Do not operate heater at the following situation
- 1 Water outlet temperature sensor, and water inlet sensor abnormal
 - 2 Flow switch abnormal
 - 3 Circulation pump stop condition
 - 4 During Heat pump switch to tank side

12.10 Tank Booster Heater Control

12.10.1 Tank booster heater control

Heating operation condition:

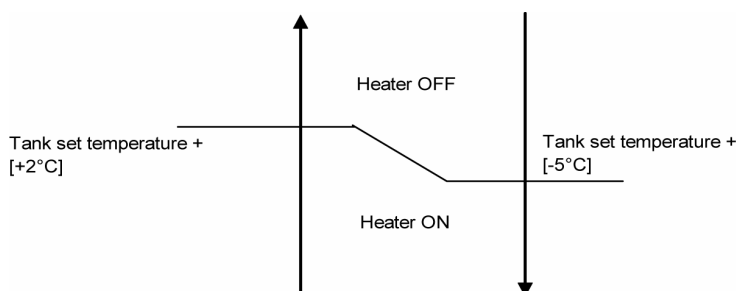

- 1 Booster heater Turn On condition:
 - After BOOSTER HEATER DELAY TIMER fulfill during heat pump startup time in tank mode, or during switching from heating heat-up interval to tank heat-up interval in heat + tank mode (heating priority not set).
 - Tank temperature < tank set temperature + [-5°C],
 - 20 minutes since previous heater off.

* BOOSTER HEATER DELAY TIMER is clear when tank heat-up interval end.
- 2 Booster heater Turn Off condition:
 - Tank temperature > tank set temperature + [+2°C] for continuous 15 secs
 - When BOOSTER HEATER DELAY TIMER start count after switch from heating heat-up interval to tank heat-up interval

* DELAY TIMER can be set by remote control.

12.11 Three Way Valve Control

- Purpose:
 - 3 ways valve is used to change flow direction of hot water from heat pump between heating side and tank side
- Control contents:
 - 1 3 ways valve switch Off:
 - During 3 ways valve switch Off time, the hot water will provide heat capacity to heating side.
 - 2 3 ways valve switch On:
 - During 3 ways valve switch On time, the hot water will provide heat capacity to tank side.
 - 3 Stop condition:
 - During stop mode, 3 ways valve will be in switch off position

12.12 Sterillization Mode

- 1 During Sterillization mode, Tank will be heat up to the Sterillize Set temperature for a certain period of time, also set by controller.
- 2 The function can only be set on timer to operate once in a week.
- 3 It will be cancelled even when the temperature is not reached after 4 hours.
- 4 When tank mode is OFF or disabled, sterillization is cancelled.

12.13 Quiet Operation

- Purpose:
 - To provide quiet operation compare to normal operation by reduces monobloc unit noise.
- Starting condition:
 - 1 When quiet button is presses.
 - 2 When quiet request ON time by weekly timer (Refer to remote control.)
- When any of above mentioned condition is achieved, this control is activated.
New target FM speed = Present target FM speed - 80 rpm
Minimum target FM speed = 200 rpm
- Cancellation condition:
 - 1 Cancel by press quiet button
 - 2 Stop by OFF/ON button
 - 3 When quiet request OFF time by weekly timer

When any of above mentioned condition is achieved, this control is cancelled.

12.14 Solar operation (Optional)

12.14.1 Solar operation

- 1 Control according to preset whether Solar Priority is set or not.
- 2 When tank connection is NOT set at SETTING mode, Solar operation is disabled.
- 3 When Pump A (from Solar pump station) is detected On through connection Y3 and Y4, then the Solar pump 3 Way Valve is requested ON (Refer to figure below).

Connecting diagram with the Solar Pump Station

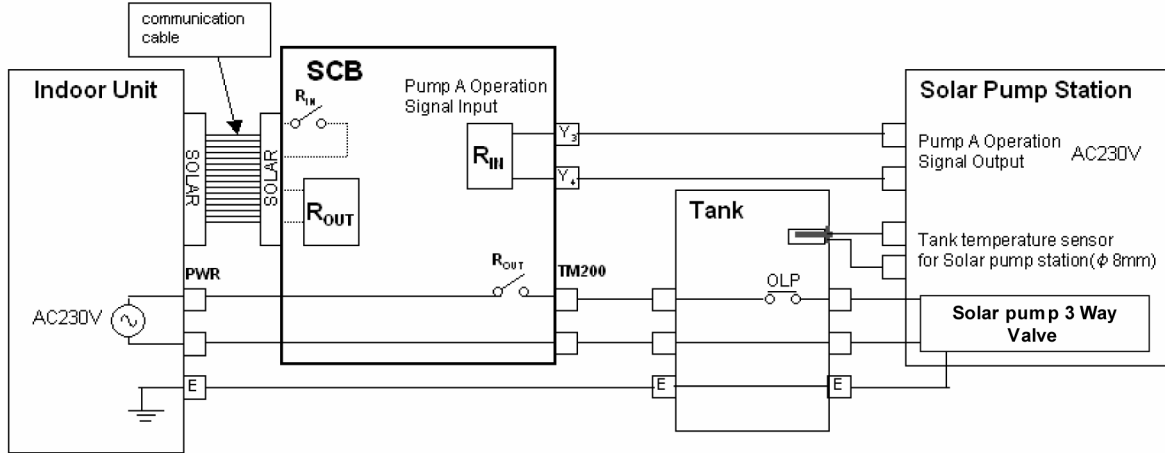

12.14.2 Solar operation control

When solar priority is SET

- 1 Operation condition:
 - a. Solar pump operates if all of the following conditions are fulfilled:-
 - Power On. (regardless operation ON or OFF).
 - There is operation request from Solar pump station.
 - Tank hot water temp is below solar on upper limit temp [EEPROM 1 : 70] °C.
 - 2 Stop condition:
 - a. Solar pump stops operating when:-
 - No power supply to unit **OR**
 - There is **NO** operation request from Solar pump station **OR**
 - Tank hot water temp is above solar off upper limit temp [EEPROM 2 : 77] °C.
- * heat pump OFF OR operate to room side when solar pump operate during solar priority set.
 * booster heater OFF when solar pump operate during solar priority set.

When solar priority is NOT SET

- 1 Operation condition:
 - a. Solar pump operates if all of the following conditions are fulfilled:-
 - Power On. (regardless operation ON or OFF).
 - There is operation request from Solar pump station.
 - Tank hot water temp is below solar on upper limit temp [EEPROM 1 : 70] °C.
 - Heat pump thermo Off in tank mode OR Heat pump operate to room side (During Operation ON and tank mode selected).
- 2 Stop condition:
 - a. Solar pump stops operating when:-
 - No power supply to unit **OR**
 - There is **NO** operation request from Solar pump station **OR**
 - Tank hot water temp is above solar off upper limit temp [EEPROM 2 : 77] °C.
 - Heat pump thermo ON and operate to tank side. (During Operation ON and tank mode selected).

Heat + Tank Mode (Heating priority not set)

(Solar Priority Set)

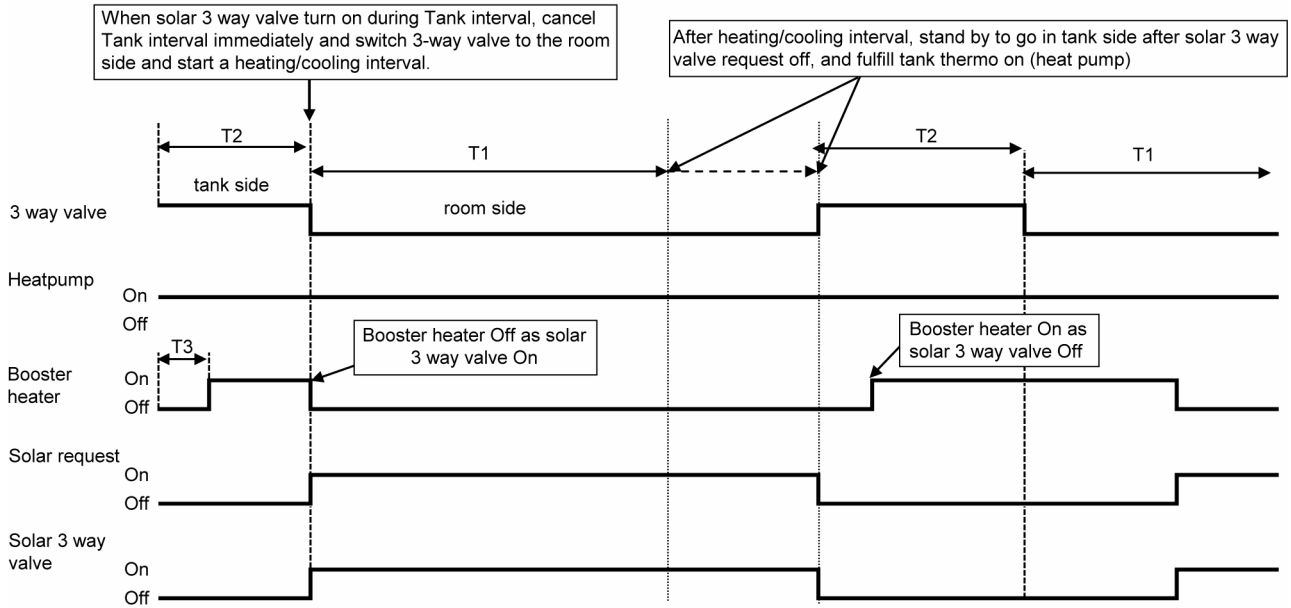

(Solar Priority Not Set)

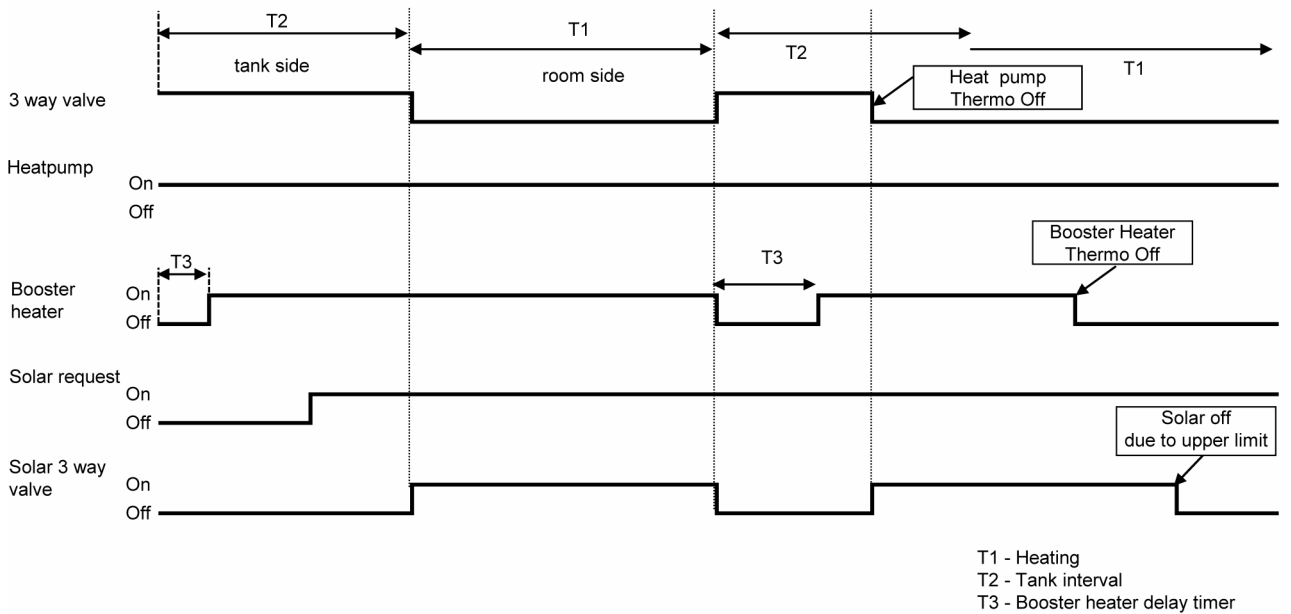

Heat + Tank Mode (Heating Priority Set)

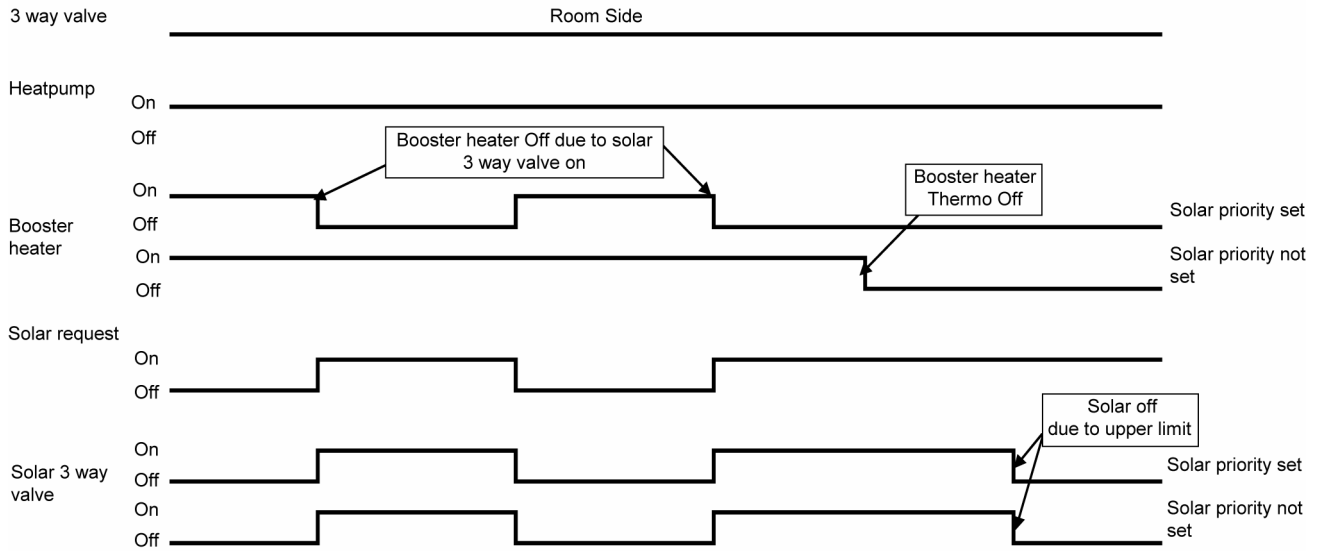

Tank Mode (Solar Priority Set)

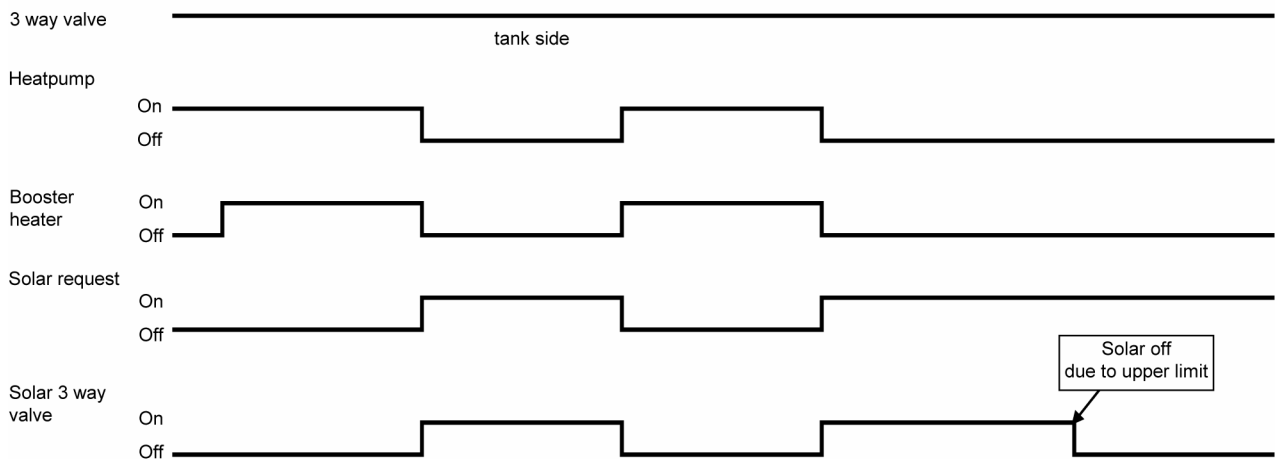

(Solar Priority Not Set)

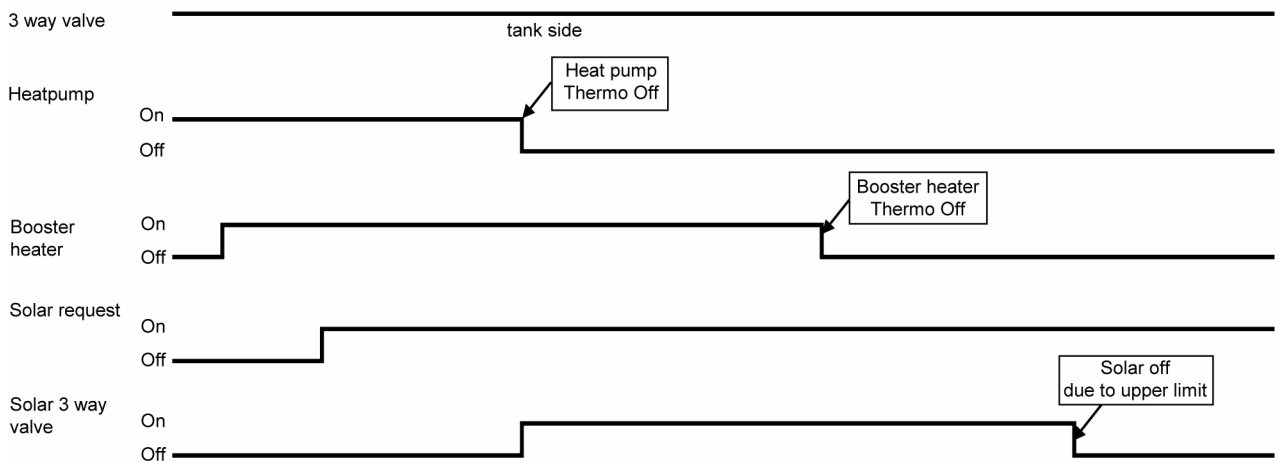

12.15 External Room Thermostat Control (Optional)

Purpose:

- Better room temperature control to fulfill different temperature request by external room thermostat.
Recommended external room thermostat:

Maker	Characteristic
Siemen (REV200)	Touch panel
Siemen (RAA20)	Analog

Connection of external room thermostat:

Wire connection and thermo characteristic of Siemen REV200:

Setting	L/L1 (H)	Heat Thermo
Set Temp < Actual Temp	Open Circuit	OFF
Set Temp > Actual Temp	Short Circuit	ON

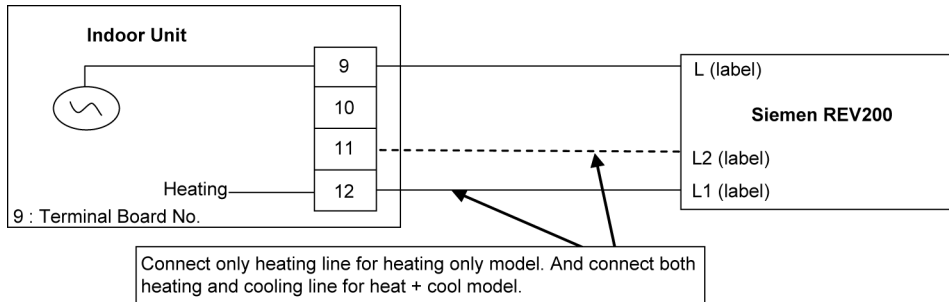

Wire connection and thermo characteristic of Siemen RAA20:

Setting	L/Y1 (H)	Heat Thermo
Set Temp < Actual Temp	Open circuit	OFF
Set Temp > Actual Temp	Short circuit	ON

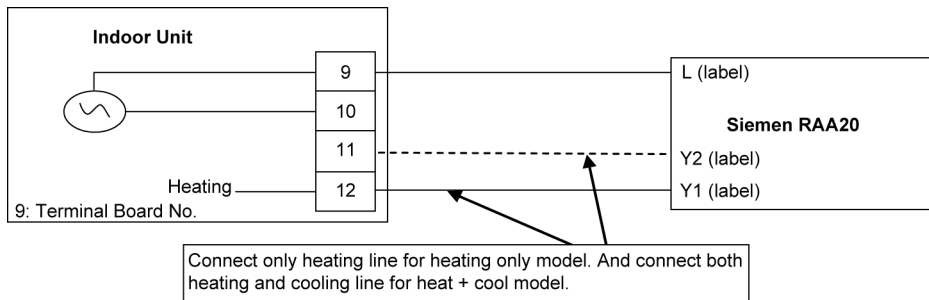

Control Content:

- External room thermostat control activate only when remote thermostat connection select YES by Indoor remote control.
- When indoor running heat mode, refer thermo On/Off from heating line feedback.
- Heat pump Off immediately when receive thermo off feedback.

13. Protection Control

13.1 Protection Control For All Operations

13.1.1 Time Delay Safety Control

- 1 The compressor will not start for three minutes after stop of operation.

13.1.2 30 Seconds Forced Operation

- 1 Once the compressor starts operation, it will not stop its operation for 30 seconds.
- 2 However, it can be stopped using remote control.

13.1.3 Total Running Current Control

- 1 When the monobloc unit running current exceeds X value, the compressor frequency will decrease.
- 2 If the monobloc unit running current does not exceed X value, the compressor frequency will return to normal operating frequency.
- 3 If the monobloc unit running current continue to increase till exceed Y value, compressor will stop, and if this occurs 3 times within 20 minutes, system will stop operation and OFF/ON remote control LED will blink (F16 error occurs).

Operation Mode	06D		09D	
	X (A)	Y (A)	X (A)	Y (A)
Heating	19.5	27.9	22.7	27.9

13.1.4 IPM (Power transistor) Prevention Control

A. Overheating Prevention Control

- 1 When the IPM temperature rises to 95°C, compressor will stop immediately.
- 2 Compressor will restart delay 3 minutes when the IPM temperature decreases to 90°C.
If this condition repeats continuously 3 times within 30 minutes, system will stop operation and OFF/ON remote control LED will blink (F22 error occurs).

B. DC Peak Current Control

- 1 When the current to IPM exceeds set value of 40.1 ± 5.0 A compressor will stop. Compressor will restart after three minutes.
- 2 If the set value exceeds again for more than 30 seconds after the compressor restarts, operation will restart after two minutes.
- 3 If the set value exceeds again for within 30 seconds after the compressor restarts, operation will restart after one minute. If this condition repeats continuously for seven times, system will stop operation and OFF/ON remote control LED will blink (F23 error occurs).

13.1.5 Compressor Overheating Prevention Control

- The compressor operating frequency is regulated in accordance to compressor tank temperature as shown in below figures. When the compressor tank temperature exceeds 112°C, compressor will stop, and if this occurs 4 times within 30 minutes, system will stop operation and OFF/ON remote control LED will blink (F20 error occurs).

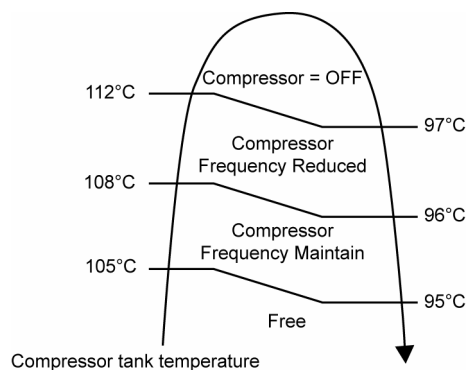

13.1.6 Low Frequency Protection Control 1

- When the compressor continuously operates at frequency lower than 25 Hz for 240 minutes, the operation frequency will change to 24 Hz for 2 minutes.

13.1.7 Low Frequency Protection Control 2

- When all the below conditions comply, the compressor frequency will change to lower frequency.

Temperature, T, for:	Heating
Outlet water (°C)	$T < 14$ or $T \geq 48$
Outdoor air (°C)	$T < 4$ or $T \geq 24$
Indoor heat exchanger (°C)	$T \geq 0$

13.1.8 High Pressure Sensor Control

- Purpose:
 - To protect the system operation.
- Detection period:
 - After compressor on for 5 minutes.
- Detection conditions:
 - When abnormal high voltage detection, 5V or when open circuit detection 0V for 5 seconds continuously.
- After detection:
 - When abnormality is detected continue 5 seconds, unit stop operation.
 - OFF/ON remote control LED will blink (H64 error occurs).

13.1.9 Outside Temperature Current Control

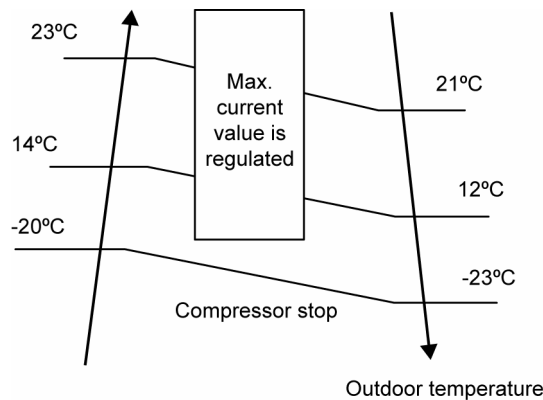

13.1.10 Crank Case Heater Control

- Purpose:
 - For compressor protection during low outdoor ambient operation (during heating low temperature operation).
- Control content:
 - a. Trigger heater START condition
 - When the outdoor air temperature is 4°C or below, and discharge temperature is 11.6°C or below.
 - b. Resetting heater STOP condition
 1. when the outdoor air temperature exceeds entry condition (6°C).
 2. when the discharge temperature exceeds entry condition (18.8°C).

13.2 Protection Control For Heating Operation

13.2.1 Outdoor Air Temperature Control

The maximum current value is regulated when the outdoor air temperature rises above 14°C in order to avoid compressor overloading.

13.2.2 Deice Operation

When Monobloc unit (Refrigerant system) pipe temperature and outdoor air temperature is low, deice operation start where monobloc unit fan motor stop.

14. Servicing Mode

14.1 Test Run

- 1 Fill up the boiler tank with water. For details refer to boiler tanks installation instruction and operation instruction.
- 2 Set ON to the monobloc unit and RCCB. Then, for remote control operation please refers to monobloc unit operation instruction.
- 3 For normal operation, pressure gauge reading should be in between 0.05 MPa and 0.3 MPa. If necessary, adjust the water pump speed accordingly to obtain normal water pressure operating range. If adjust water pump speed cannot solve the problem, contact your local authorized dealer.

14.2 Proper Pump Down Procedure

- 1 Make sure the OFF/ON remote control LED is OFF (no operation).
- 2 Press the "PUMPDW" switch on remote control to begin PUMP DOWN mode. Operate the system in PUMP DOWN mode for 10 ~ 15 minutes.
- 3 After 10-15 minutes, (after 1 or 2 minutes in case very low ambient temperatures ($< 10^{\circ}\text{C}$)), fully close 3 way valve (Liquid side).
- 4 After 3 minutes, fully close 3 way valve (Gas side).
- 5 Press the "OFF/ON" switch on remote control to stop PUMP DOWN mode.
- 6 Remove the refrigerant piping.

14.3 How To Adjust Water Flow Rate

- Before adjust the water flow rate, make sure that the total water volume in the installation is 30 litres minimum.
- The water flow rate can be adjusted with select the water pump speed on the water pump. The default setting is high speed (III). Adjust it to moderate speed (II) and slow speed (I) if necessary (e.g. reduce the noise of running water).

Below graph shown the external static pressure (kPa) versus water flow rate (l/min).

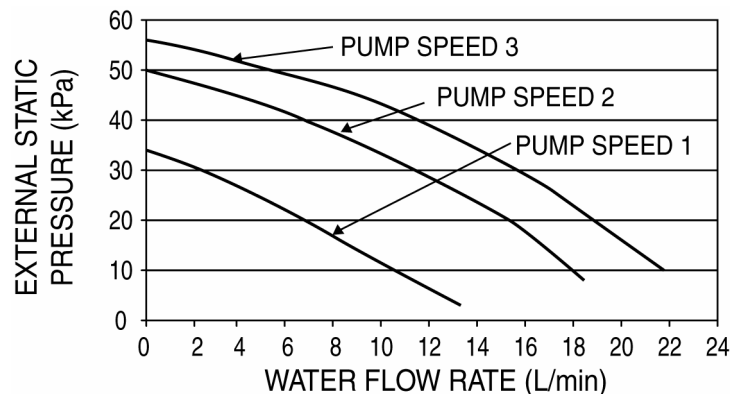

- Flow rate characteristic of indoor unit is as per above mentioned.

14.4 Expansion Vessel Pre Pressure Checking

- Expansion Vessel with 6L air capacity and initial pressure of 1 bar is installed in this monobloc unit.
- Total amount of water in system should be below 150L.
(Note: This amount of water is not include the tank unit volume)
- If total amount of water is over 150L, please add expansion vessel.
- Please keep the installation height difference of system water circuit within 7m.
(Inner volume of same monobloc unit is about 3L)

15. Maintenance Guide

In order to ensure optimal performance of the unit, checks and inspections on the unit and the field wiring must be carried out regularly. Please request a licensed technician for carry out maintenance job.

Before carried out any maintenance or repair work, and removing the front plate of heat exchanger unit, always switch off all power supply (i.e. monobloc unit power supply, heater power supply and sanitary tank power supply). Below checks must be carried out at least once a year.

1 Water pressure

Water pressure should not lower than 0.05 MPa (with inspects the pressure gauge). If necessary add tap water into boiler tank. Refer to boiler tank installation instruction for details on how to add water.

2 Pressure relief valve

- Take out the cover with remove the mounting screw for access to the pressure relief valve.
- Check for correction operation of pressure relief valve by turn up the lever to become horizontal. (Refer to figure below)
- If you do not hear a clacking sound (due to water drainage), contact your local authorized dealer.
- Turn down the lever after checking finish.
- In case the water keeps drained out from the unit, switch off the system, and then contact your local authorized dealer.
- Reinstall the cover with tighten the mounting screws properly, if the pressure relief valve is functioning normal.

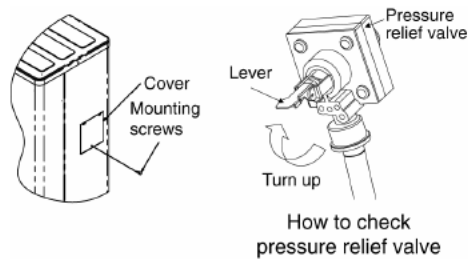

3 Indoor unit control board area

Thorough visual inspection of the control board and look for defects, i.e. loose connection, melting of wire insulator and etc.

4 RCCB

Ensure the RCCB set to "ON" condition before check RCCB.

Turn on the power supply to the monobloc unit.

This testing could only be done when power is supplied to the monobloc unit.

WARNING

Be careful not to touch parts other than RCCB test button when the power is supplied to Monobloc Unit. Else, electrical shock may happen.

- Push the "TEST" button on the RCCB. The lever would turn down and indicate "0" and indicate green colour if it functions normal.
- Contact authorized dealer if the RCCB malfunction.
- Turn off the power supply to the monobloc unit.
- If RCCB functions normal, set the lever to "ON" again after testing finish.

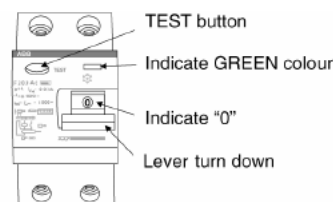

Condition of RCCB - function normal
(after press "TEST" button)

5 How to release the trapped air in water circuit

- Turn up the lever to become horizontal. (Refer to figure "Pressure relief valve"). The trapped air will be drained out together with water. After few seconds, turn down the lever to stop the water drainage.
- Repeat it until the bubbling sound disappear.

6 Reset overload protector

Overload Protector serves the safety purpose to prevent the water over heating. When the Overload Protector trip at high water temperature, take below steps to reset it.

- a. Take out OLP Cover.
- b. Use a test pen to push the centre button gently in order to reset the Overload protector.
- c. After finish, install back the Overload protector following the reverse order of step a & b.

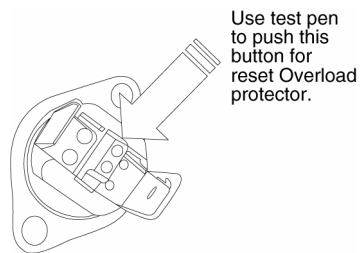

How to reset Overload protector

7 External water filter (field supply)

Clean the external water filter in regularly basic.

- External water filter is located inside the tube connector which is before water inlet connector of monobloc unit (indicated with "WATER IN"). (Refer to figure below)
- Use spanner to detach the tube connector nut.
- Take out the filter carefully so that not deforms it shape.
- Use tap water only to wash the residue on the filter. If necessary, gently use soft brush only to clean the hard dirt.
- After clean, put it back to the original location and tighten the nut connection with torque wrench.

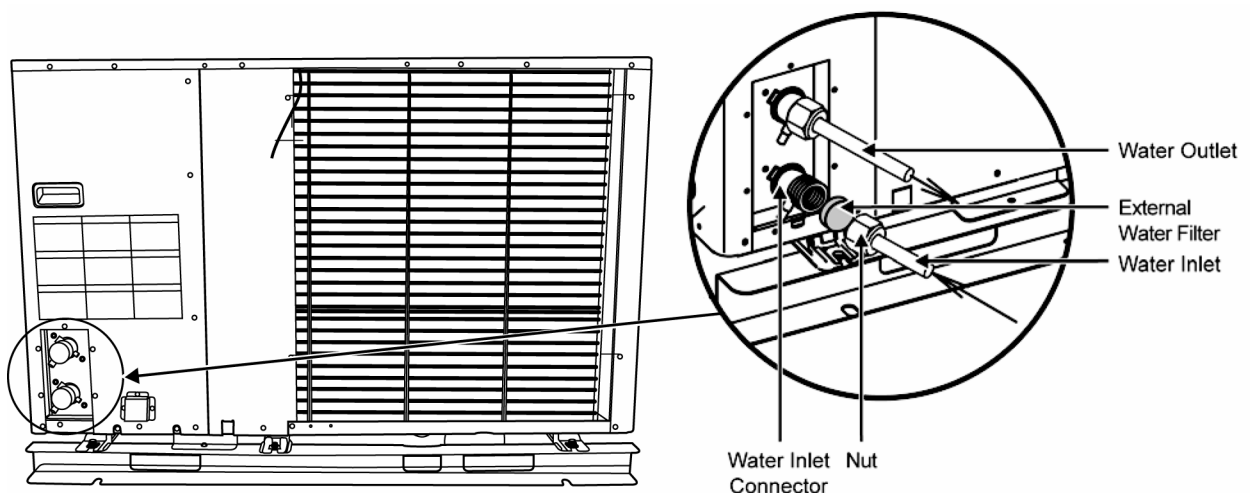

Location Of External Water Filter

16. Troubleshooting Guide

16.1 Refrigeration Cycle System

In order to diagnose malfunctions, make sure that there are no electrical problems before inspecting the refrigeration cycle.

Such problems include insufficient insulation, problem with the power source, malfunction of a compressor and a fan.

The normal pressure of the refrigeration cycle depends on various conditions, the standard values for them are shown in the table on the right.







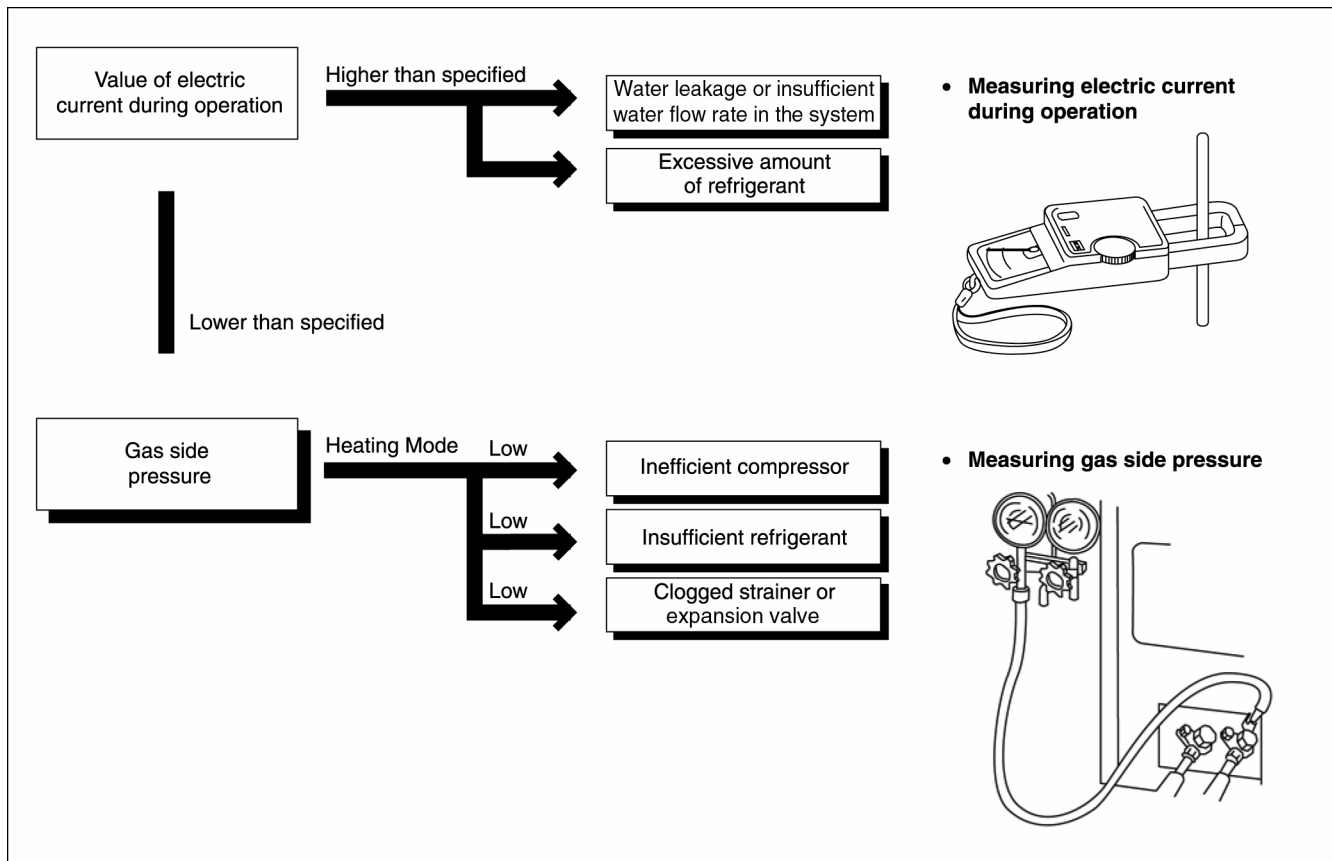











Normal Pressure (Standard)

	Gas pressure MPa (kg/cm ² G)
Heating Mode	2.3 ~ 2.9 (23 ~ 29)

- ★ Condition: • Outdoor temperature 7°C at heating mode.
- Compressor operates at rated frequency.



16.2 Relationship Between The Condition Of The Monobloc Unit And Pressure And Electric Current

Condition of the Monobloc Unit	Heating Mode		
	Low Pressure	High Pressure	Electric current during operation
Water leakage or insufficient water flow rate in the system			
Excessive amount of refrigerant			
Inefficient compression			
Insufficient refrigerant (gas leakage)			
Monobloc unit (refrigerant system) heat exchange deficiency			
Clogged expansion valve or Strainer			

- Carry out the measurements of pressure, electric current, and temperature fifteen minutes after an operation is started.

16.3 Breakdown Self Diagnosis Function

16.3.1 Self Diagnosis Function (Three Digits Alphanumeric Code)

- When abnormality occur during operation, the system will stop operation, and OFF/ON remote control LED will blink and error code will display on the remote control Timer display LCD.
- Even error code is reset by turning OFF power supply or by pressing ERROR RESET button, if the system abnormality is still un-repaired, system will again stop operation, and OFF/ON remote control LED will again blink.
- The error code will store in IC memory.
- **To check the error code**
 - 1 When an abnormality occurs, system will stop operation and OFF/ON remote control LED will blink.
 - 2 Error code of the abnormality will display on the remote control Timer display LCD.
 - 3 To determine the abnormality description, the Error Code Table needs to be referred.
- **To display past/last error code**
 - 1 Turn ON power supply.
 - 2 Press and hold the CHECK button for more than 5 seconds to enter status mode.
 - 3 Press the SEARCH DOWN/UP button to retrieve past/last error code.
 - 4 Press the CANCEL button or wait 30 seconds to exit status mode.
- **To permanently delete error code from IC memory**
 - 1 Turn ON power supply.
 - 2 Press and hold the ERROR RESET button for more than 8 seconds till a beep sound is heard.

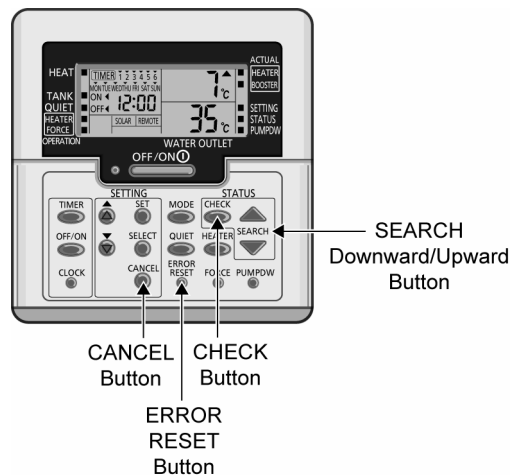

16.4 Error Codes Table

Diagnosis display	Abnormality/Protection control	Abnormality Judgement	Primary location to verify
H00	No abnormality detected	—	—
H12	Indoor/Outdoor capacity unmatched	90s after power supply	<ul style="list-style-type: none"> Indoor/outdoor connection wire Indoor/outdoor PCB Specification and combination table in catalogue
H15	Outdoor compressor temperature sensor abnormality	Continue for 5 sec.	<ul style="list-style-type: none"> Compressor temperature sensor (defective or disconnected)
H23	Indoor refrigerant liquid temperature sensor abnormality	Continue for 5 sec.	<ul style="list-style-type: none"> Refrigerant liquid temperature sensor (defective or disconnected)
H42	Compressor low pressure abnormality	—	<ul style="list-style-type: none"> Outdoor pipe temperature sensor Clogged expansion valve or strainer Insufficient refrigerant Outdoor PCB Compressor
H62	Water flow switch abnormality	Continue for 1 min.	<ul style="list-style-type: none"> Water flow switch
H64	Refrigerant high pressure abnormality	Continue for 5 sec.	<ul style="list-style-type: none"> Outdoor high pressure sensor (defective or disconnected)
H70	Back-up heater OLP abnormality	Continue for 60 sec.	<ul style="list-style-type: none"> Back-up heater OLP (Disconnection or activated)
H72	Tank sensor abnormal	Continue for 5 sec.	<ul style="list-style-type: none"> Tank sensor
H76	Indoor – remote control communication abnormality	—	<ul style="list-style-type: none"> Indoor - control panel (defective or disconnected)
H90	Indoor/outdoor abnormal communication	> 1 min after starting operation	<ul style="list-style-type: none"> Internal/external cable connections Indoor/Outdoor PCB
H91	Tank heater OLP abnormality	Continue for 60 sec.	<ul style="list-style-type: none"> Tank heater OLP (Disconnection or activated)
H95	Indoor/Outdoor wrong connection	—	<ul style="list-style-type: none"> Indoor/Outdoor supply voltage
H98	Outdoor high pressure overload protection	—	<ul style="list-style-type: none"> Outdoor high pressure sensor Water pump or water leakage Clogged expansion valve or strainer Excess refrigerant Outdoor PCB
H99	Indoor heat exchanger freeze prevention	—	<ul style="list-style-type: none"> Indoor heat exchanger Refrigerant shortage
F12	Pressure switch activate	4 times occurrence within 20 minutes	<ul style="list-style-type: none"> Pressure switch
F14	Outdoor compressor abnormal revolution	4 times occurrence within 20 minutes	<ul style="list-style-type: none"> Outdoor compressor
F15	Outdoor fan motor lock abnormality	2 times occurrence within 30 minutes	<ul style="list-style-type: none"> Outdoor PCB Outdoor fan motor
F16	Total running current protection	3 times occurrence within 20 minutes	<ul style="list-style-type: none"> Excess refrigerant Outdoor PCB
F20	Outdoor compressor overheating protection	4 times occurrence within 30 minutes	<ul style="list-style-type: none"> Compressor tank temperature sensor Clogged expansion valve or strainer Insufficient refrigerant Outdoor PCB Compressor
F22	IPM (power transistor) overheating protection	3 times occurrence within 30 minutes	<ul style="list-style-type: none"> Improper heat exchange IPM (Power transistor)
F23	Outdoor Direct Current (DC) peak detection	7 times occurrence continuously	<ul style="list-style-type: none"> Outdoor PCB Compressor
F24	Refrigeration cycle abnormality	2 times occurrence within 20 minutes	<ul style="list-style-type: none"> Insufficient refrigerant Outdoor PCB Compressor low compression
F25	Cooling/Heating cycle changeover abnormality	4 times occurrence within 30 minutes	<ul style="list-style-type: none"> 4-way valve V-coil
F27	Pressure switch abnormality	Continue for 1 min.	<ul style="list-style-type: none"> Pressure switch
F36	Outdoor air temperature sensor abnormality	Continue for 5 sec.	<ul style="list-style-type: none"> Outdoor air temperature sensor (defective or disconnected)
F37	Indoor water inlet temperature sensor abnormality	Continue for 5 sec.	<ul style="list-style-type: none"> Water inlet temperature sensor (defective or disconnected)
F40	Outdoor discharge pipe temperature sensor abnormality	Continue for 5 sec.	<ul style="list-style-type: none"> Outdoor discharge pipe temperature sensor (defective or disconnected)

Diagnosis display	Abnormality/Protection control	Abnormality Judgement	Primary location to verify
F41	PFC control	4 times occurrence within 10 minutes	<ul style="list-style-type: none"> • Voltage at PFC
F42	Outdoor heat exchanger temperature sensor abnormality	Continue for 5 sec.	<ul style="list-style-type: none"> • Outdoor heat exchanger temperature sensor (defective or disconnected)
F43	Outdoor defrost sensor abnormality	Continue for 5 sec.	<ul style="list-style-type: none"> • Outdoor defrost sensor (defective or disconnected)
F45	Indoor water outlet temperature sensor abnormality	Continue for 5 sec.	<ul style="list-style-type: none"> • Water outlet temperature sensor (defective or disconnected)
F46	Outdoor Current Transformer open circuit	—	<ul style="list-style-type: none"> • Insufficient refrigerant • Outdoor PCB • Compressor low
F95	Cooling high pressure overload protection	—	<ul style="list-style-type: none"> • Outdoor high pressure sensor • Water pump or water leakage • Clogged expansion valve or strainer • Excess refrigerant • Outdoor PCB

16.5 Self-diagnosis Method

16.5.1 Connection Capability Rank Abnormality (H12)

Malfunction Decision Conditions:

During startup operation of cooling and heating, the capability rank of indoor checked by the outdoor is used to determine connection capability rank abnormality.

Malfunction Caused:

- 1 Wrong model interconnected.
- 2 Wrong indoor unit or outdoor unit PCB (main) used.
- 3 Faulty indoor unit or outdoor unit PCB (main).

Abnormality Judgment:

Continue for 90 seconds.

Troubleshooting:

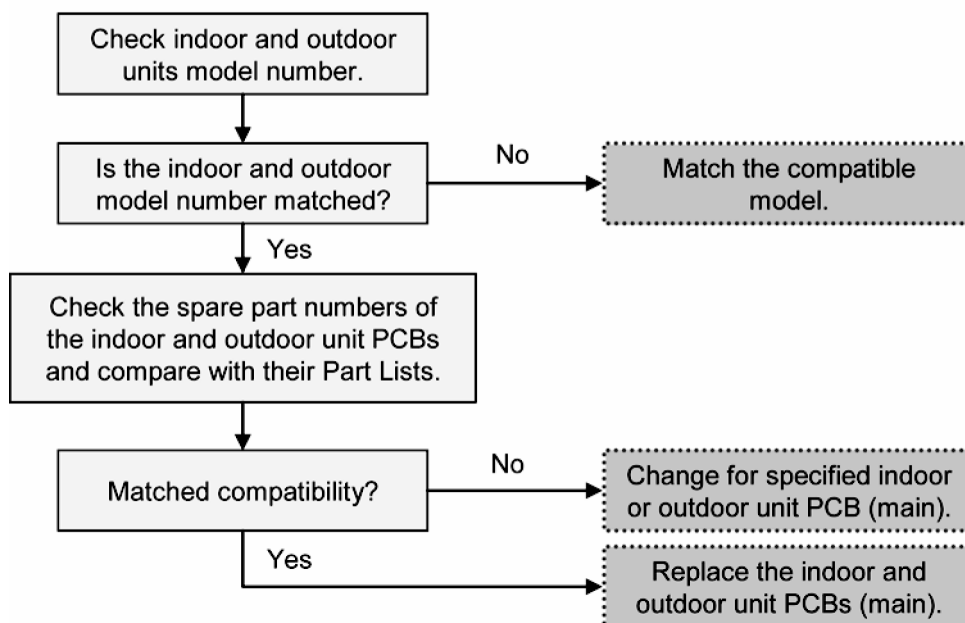

16.5.2 Compressor Tank Temperature Sensor Abnormality (H15)

Malfunction Decision Conditions:

During startup and operation of cooling and heating, the temperatures detected by the compressor tank temperature sensor are used to determine sensor error.

Malfunction Caused:

- 1 Faulty connector connection.
- 2 Faulty sensor.
- 3 Faulty outdoor unit PCB (main).

Abnormality Judgment:

Continue for 5 seconds.

Troubleshooting:

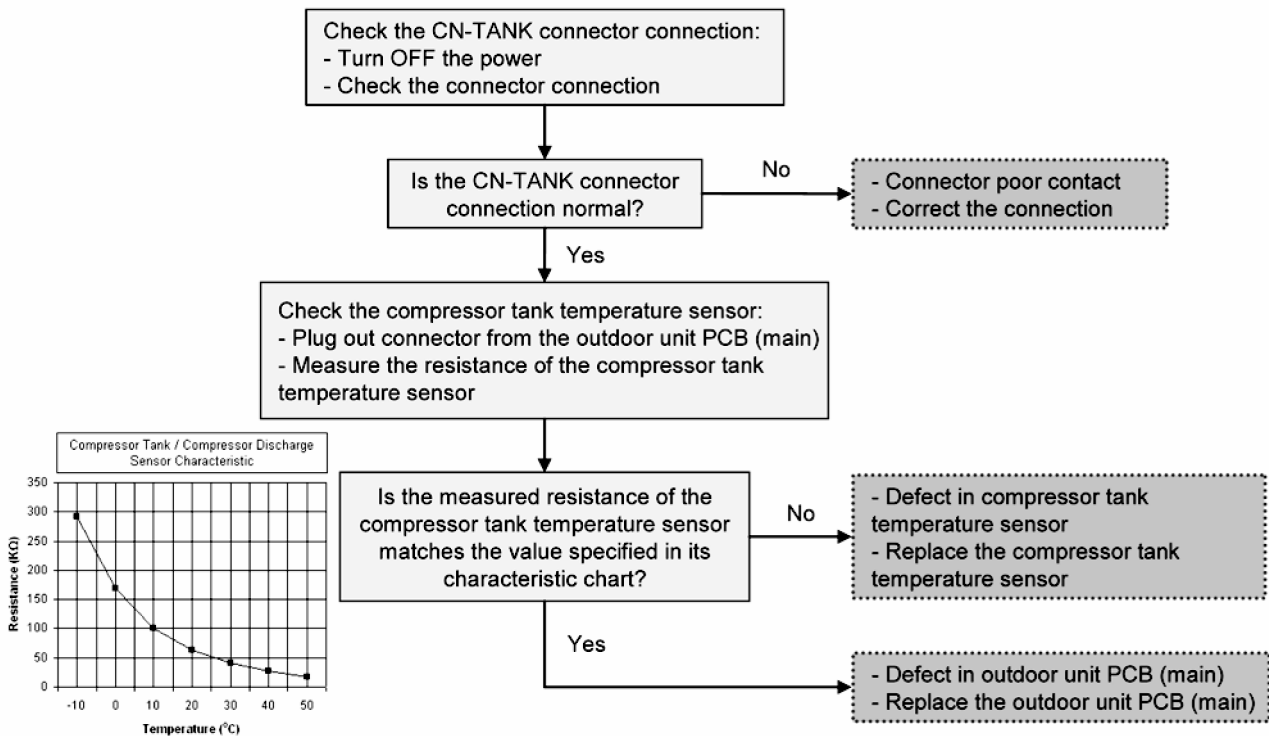

16.5.3 Indoor Refrigerant Liquid Temperature Sensor Abnormality (H23)

Malfunction Decision Conditions:

During startup and operation of cooling and heating, the temperatures detected by the indoor refrigerant liquid temperature sensor are used to determine sensor error.

Malfunction Caused:

- 1 Faulty connector connection.
- 2 Faulty sensor.
- 3 Faulty indoor unit PCB (main).

Abnormality Judgment:

Continue for 5 seconds.

Troubleshooting:



Caution

For safety reason and to prevent component breakdown, always switch off the power before remove and connect the component.

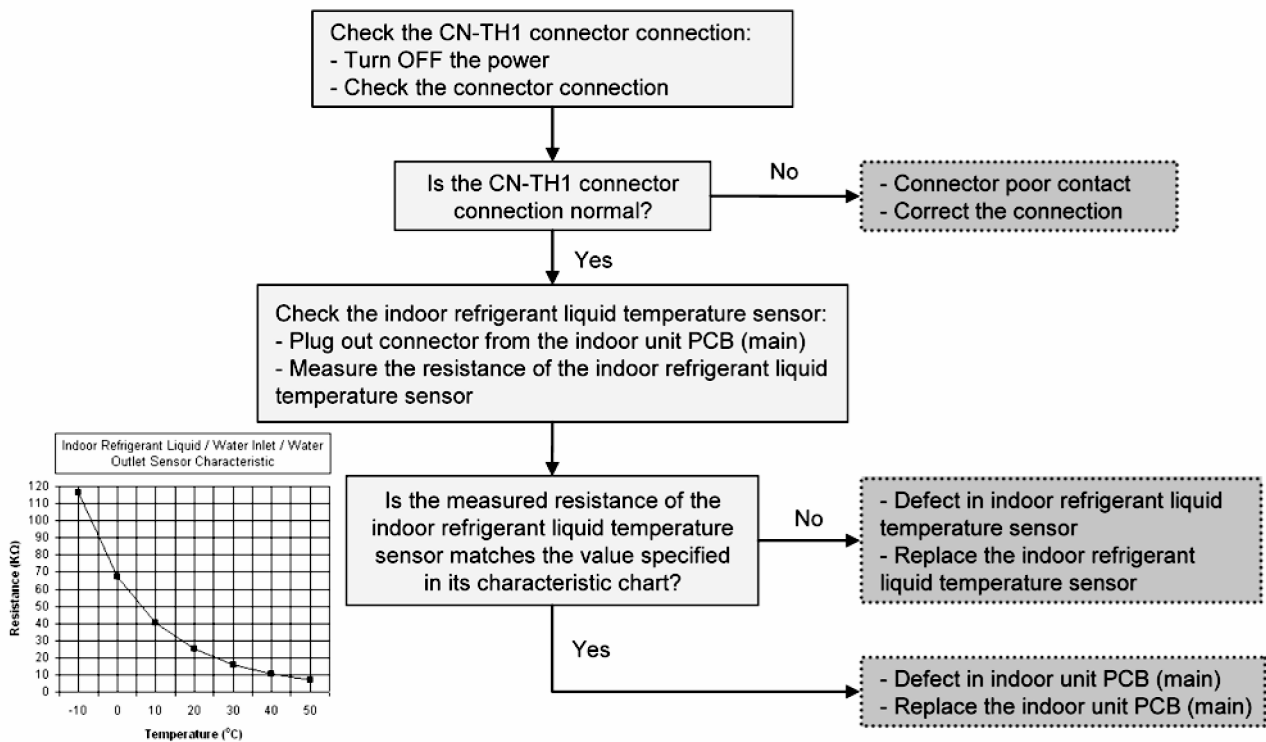

16.5.4 Compressor Low Pressure Protection (H42)

Malfunction Decision Conditions:

During operation of heating and after 5 minutes compressor ON, when outdoor pipe temperature below -29°C or above 26°C is detected by the outdoor pipe temperature sensor.

Malfunction Caused:

- 1 Dust accumulation on the outdoor unit heat exchanger.
- 2 Air short circuit at outdoor unit.
- 3 2 way valve partially closed.
- 4 Faulty outdoor unit fan motor.
- 5 Refrigerant shortage (refrigerant leakage).
- 6 Clogged expansion valve or strainer.
- 7 Faulty outdoor pipe temperature sensor.
- 8 Faulty outdoor unit main PCB (main).

Troubleshooting:



For safety reason and to prevent component breakdown, always switch off the power before remove and connect the component.

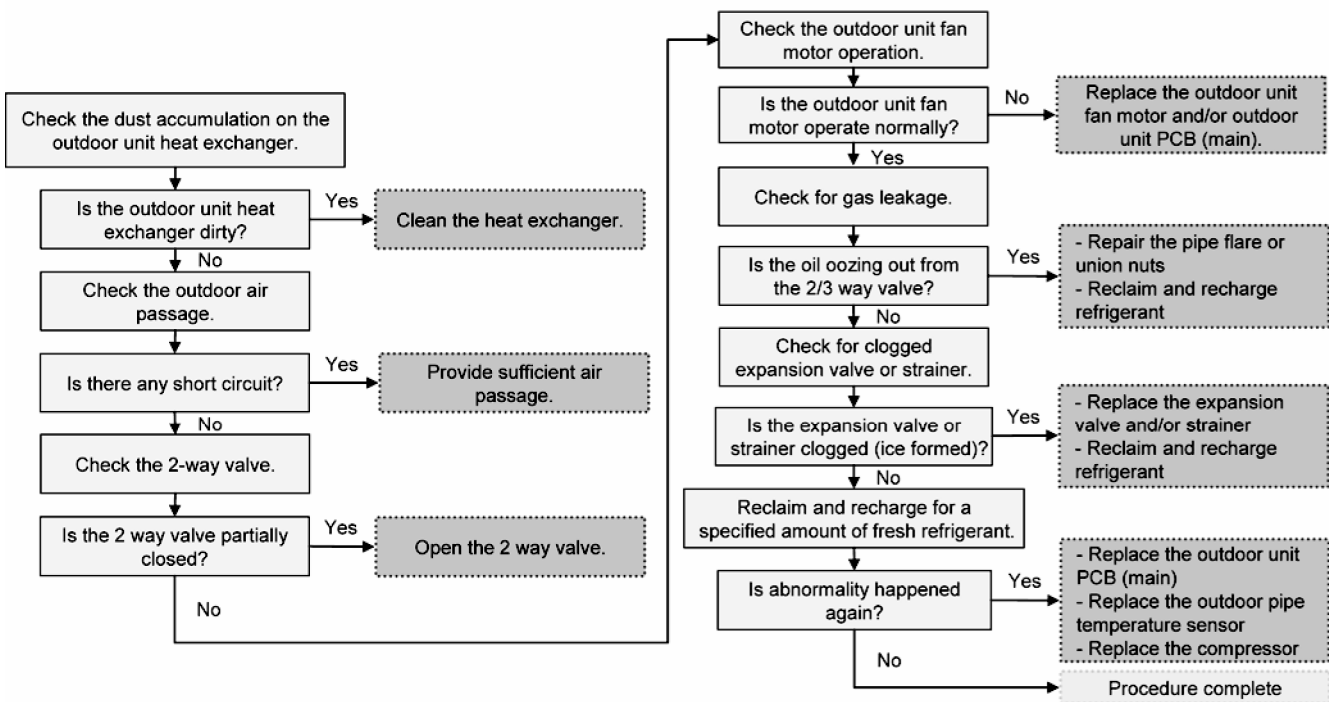

16.5.5 Water Flow Switch Abnormality (H62)

Malfunction Decision Conditions:

During operation of cooling and heating, the water flow detected by the indoor water flow switch is used to determine water flow error.

Malfunction Caused:

- 1 Faulty water pump.
- 2 Water leak in system.
- 3 Faulty connector connection.
- 4 Faulty water flow switch.
- 5 Faulty indoor unit PCB (main).

Abnormality Judgment:

Continue for 10 seconds (but no judgment for 9 minutes after compressor startup/restart).

Troubleshooting:



Caution

For safety reason and to prevent component breakdown, always switch off the power before remove and connect the component.

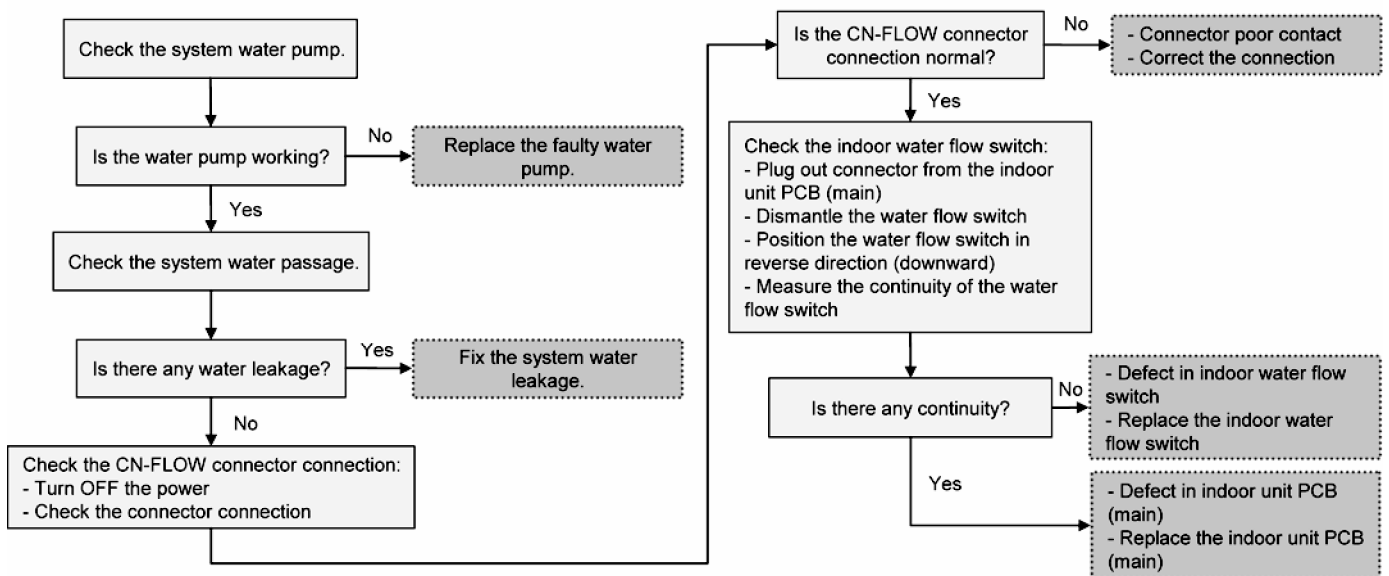

16.5.6 Outdoor High Pressure Abnormality (H64)

Malfunction Decision Conditions:

During operation of cooling and heating, when the outdoor high pressure sensor output signal is 0Vdc or 5Vdc.

Malfunction Caused:

- 1 Faulty connector connection.
- 2 Faulty sensor.
- 3 Faulty outdoor unit PCB (main).

Abnormality Judgment:

Continue 4 times in 20 minutes.

Troubleshooting:



Caution

For safety reason and to prevent component breakdown, always switch off the power before remove and connect the component.

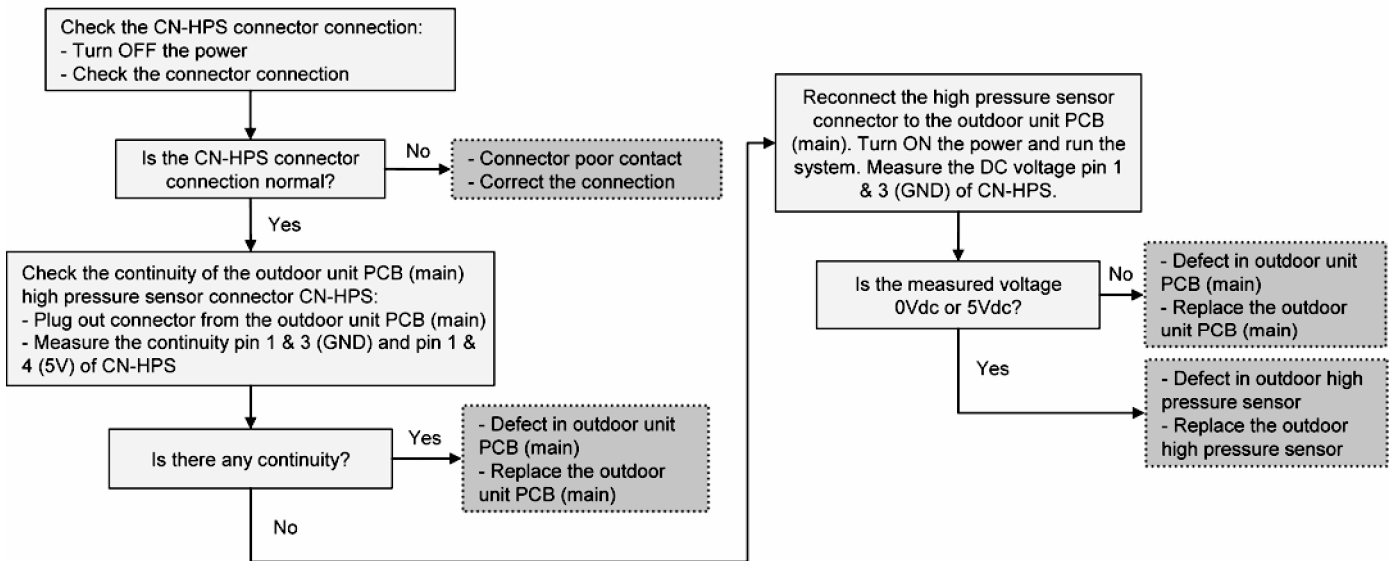

16.5.7 Indoor Backup Heater OLP Abnormality (H70)

Malfunction Decision Conditions:

During operation of indoor backup heater, when no power supplies to indoor backup heater or OLP open circuit.

Malfunction Caused:

- 1 Faulty power supply connector connection.
- 2 Faulty connector connection.
- 3 Faulty indoor backup heater overload protector (OLP).
- 4 Faulty indoor unit PCB (main).

Abnormality Judgment:

Continue for 60 seconds.

Troubleshooting:



For safety reason and to prevent component breakdown, always switch off the power before remove and connect the component.

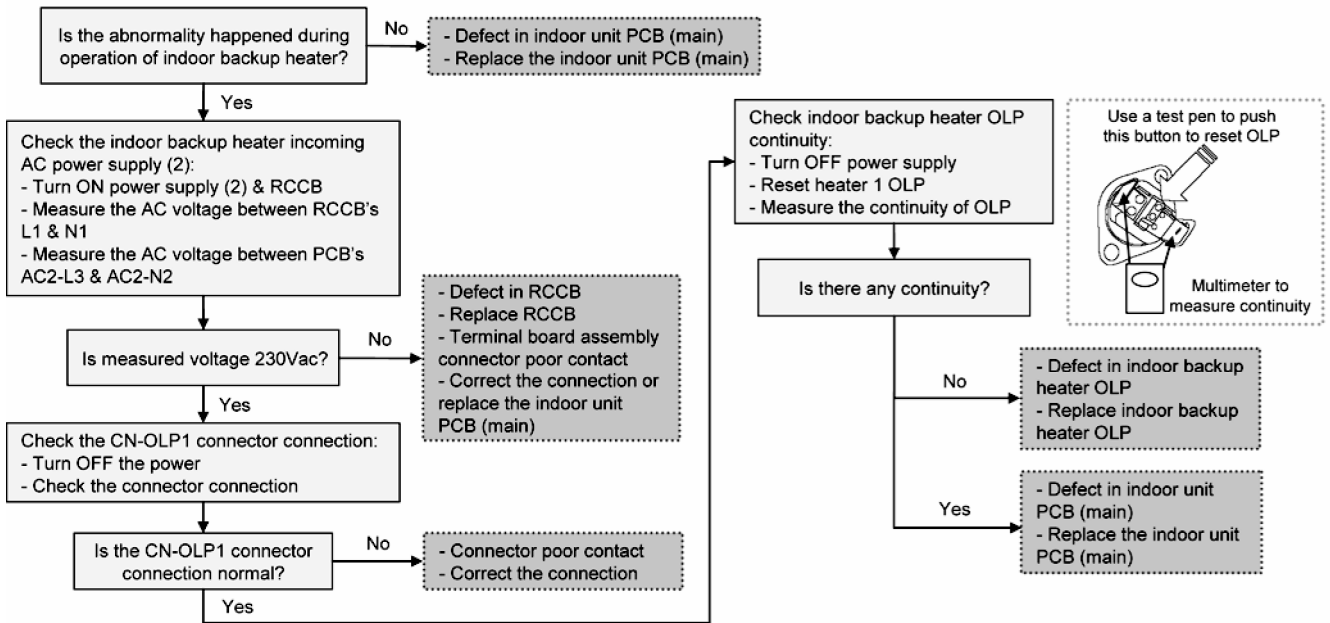

16.5.8 Tank Temperature Sensor Abnormality (H72)

Malfunction Decision Conditions:

When tank connection is set to ON, the temperatures detected by the tank temperature sensor are used to determine sensor error.

Malfunction Caused:

- 1 Faulty connector connection.
- 2 Faulty sensor.
- 3 Faulty indoor unit PCB (main).

Abnormality Judgment:

Continue for 5 seconds.

Troubleshooting:



Caution

For safety reason and to prevent component breakdown, always switch off the power before remove and connect the component.

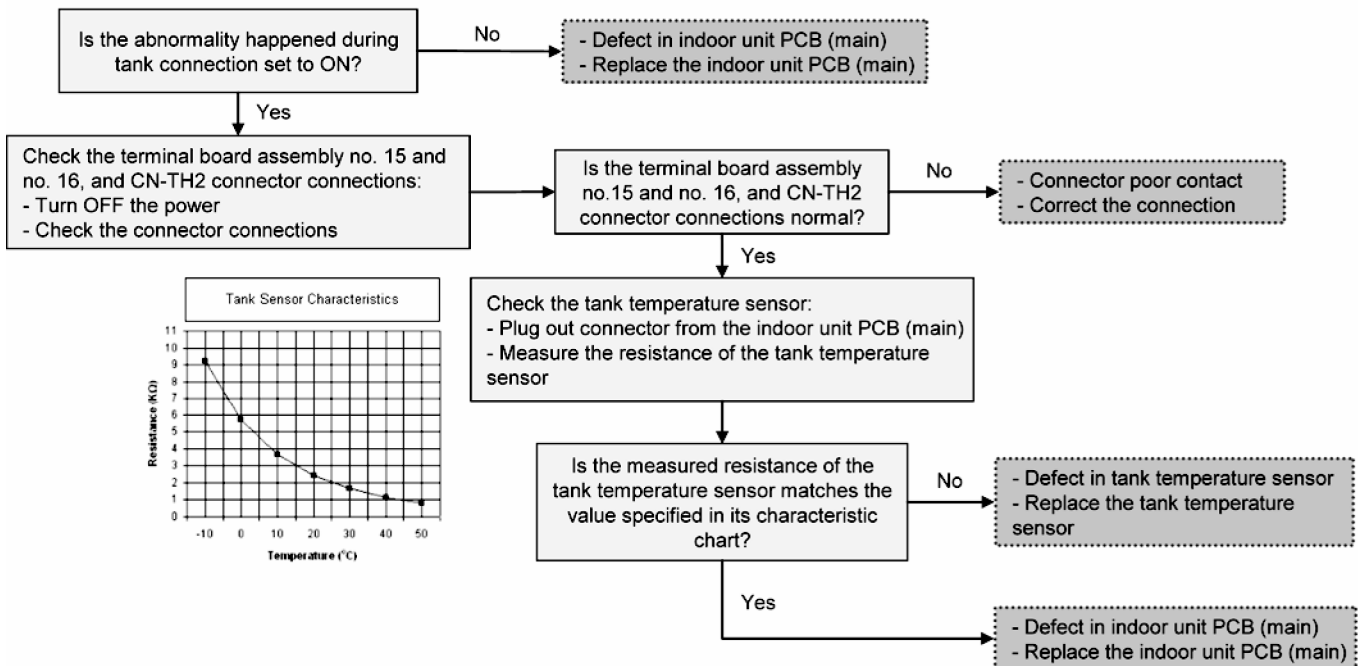

16.5.9 Indoor-Control Panel Communication Abnormality (H76)

Malfunction Decision Conditions:

During standby and operation of cooling and heating, indoor-remote control error occur.

Malfunction Caused:

- 1 Faulty connector connection.
- 2 Faulty remote control.
- 3 Faulty indoor unit PCB (main).

Troubleshooting:



Caution

For safety reason and to prevent component breakdown, always switch off the power before remove and connect the component.

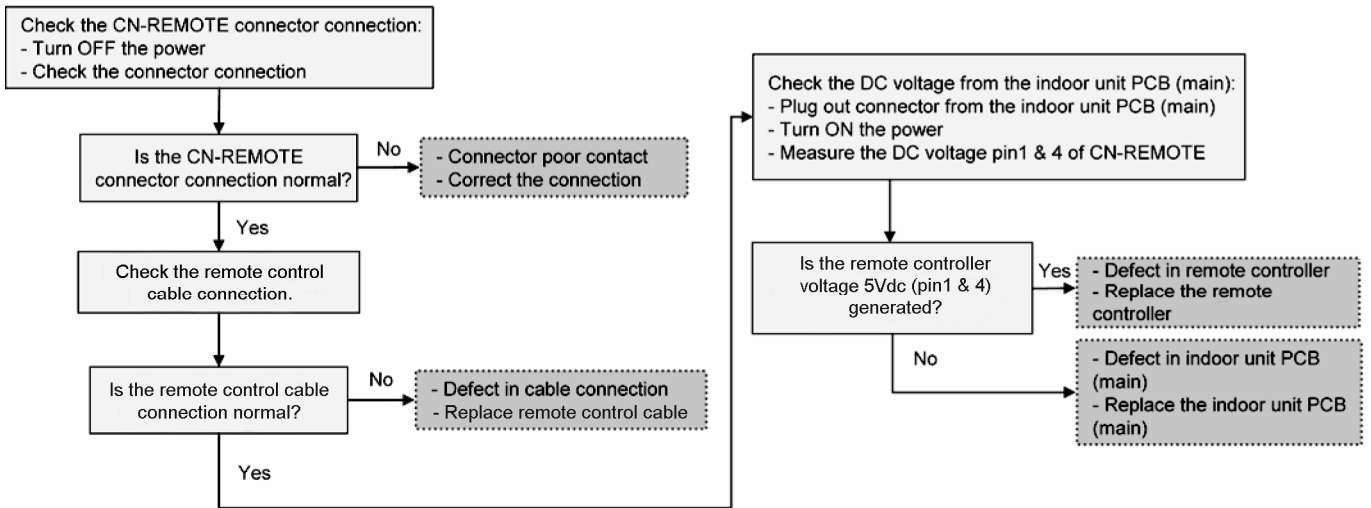

16.5.10 Indoor/Outdoor Abnormal Communication (H90)

Malfunction Decision Conditions:

During operation of cooling and heating, the data received from outdoor unit in indoor unit signal transmission is checked whether it is normal.

Malfunction Caused:

- 1 Faulty outdoor unit PCB (main).
- 2 Faulty indoor unit PCB (main).
- 3 Indoor-outdoor signal transmission error due to wrong wiring.
- 4 Indoor-outdoor signal transmission error due to breaking of wire in the connection wires between the indoor and outdoor units.
- 5 Indoor-outdoor signal transmission error due to disturbed power supply waveform.

Abnormality Judgment:

Continue for 1 minute after operation.

Troubleshooting:



For safety reason and to prevent component breakdown, always switch off the power before remove and connect the component.

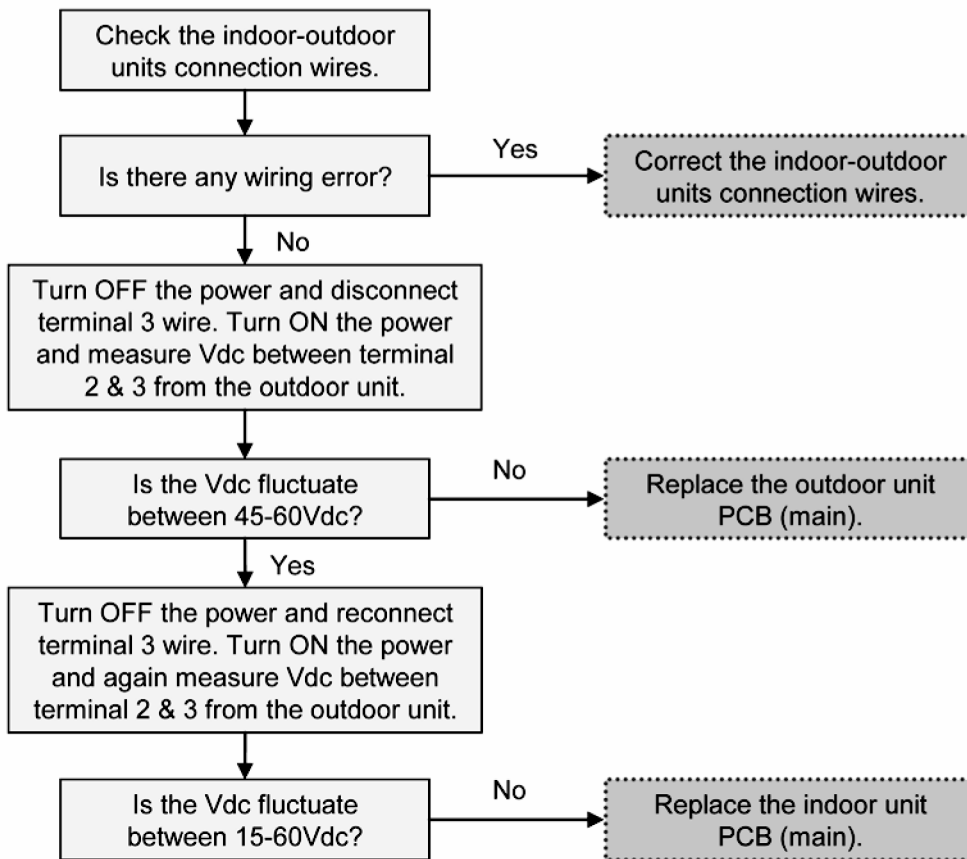

16.5.11 Tank Booster Heater OLP Abnormality (H91)

Malfunction Decision Conditions:

During operation of tank booster heater, and tank booster heater OLP open circuit.

Malfunction Caused:

- 1 Faulty connector connection.
- 2 Faulty tank booster heater overload protector (OLP).
- 3 Faulty indoor unit PCB (main).

Abnormality Judgment:

Continue for 60 seconds.

Troubleshooting:  **Caution**

For safety reason and to prevent component breakdown, always switch off the power before remove and connect the component.

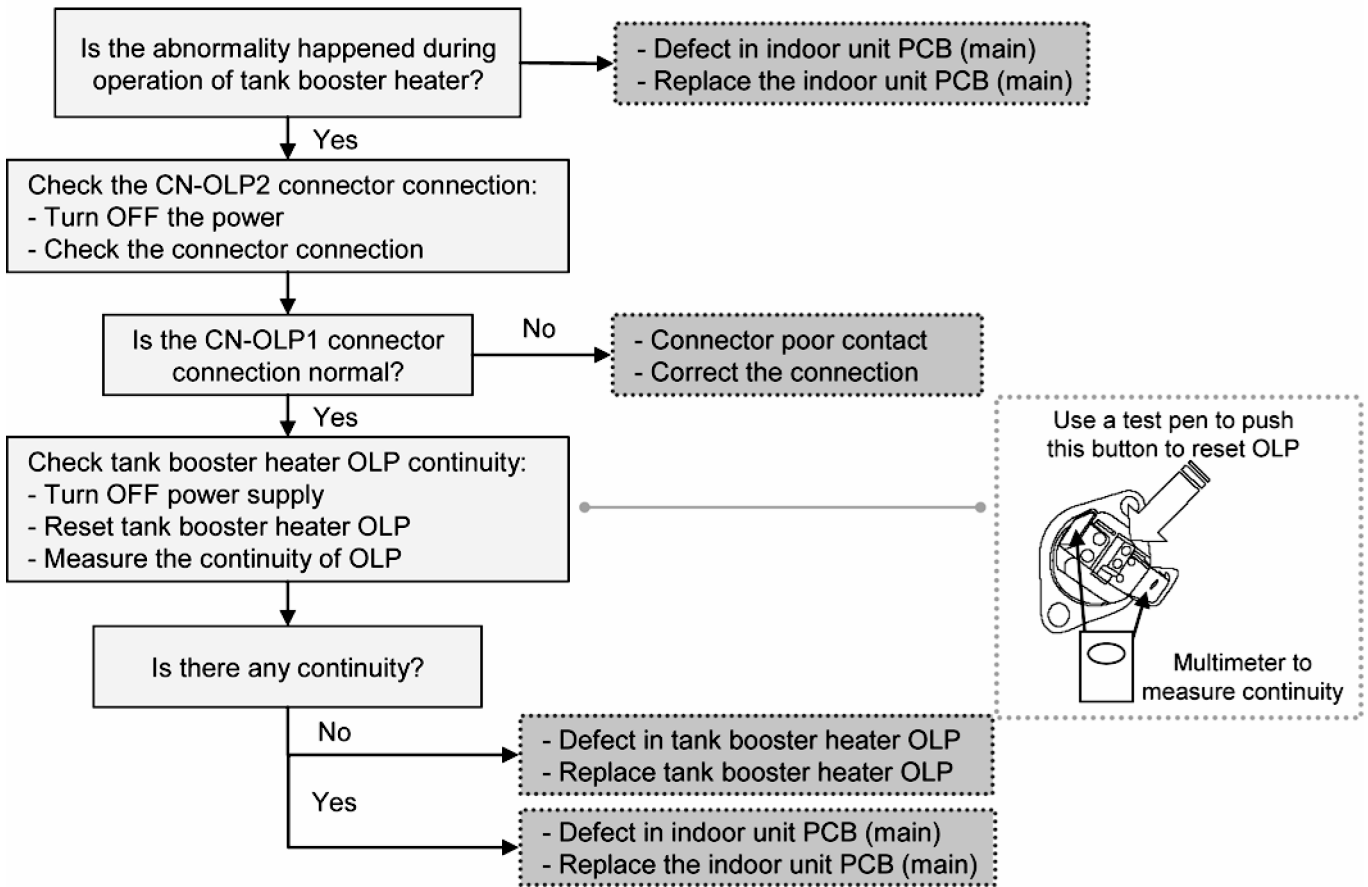

16.5.12 Unspecified Voltage between Indoor and Outdoor (H95)

Malfunction Decision Conditions:

The supply power is detected for its requirement by the indoor/outdoor transmission.

Malfunction Caused:

- 1 Insufficient power supply.
- 2 Faulty outdoor unit PCB (noise filter/main).

Troubleshooting:



Caution

For safety reason and to prevent component breakdown, always switch off the power before remove and connect the component.

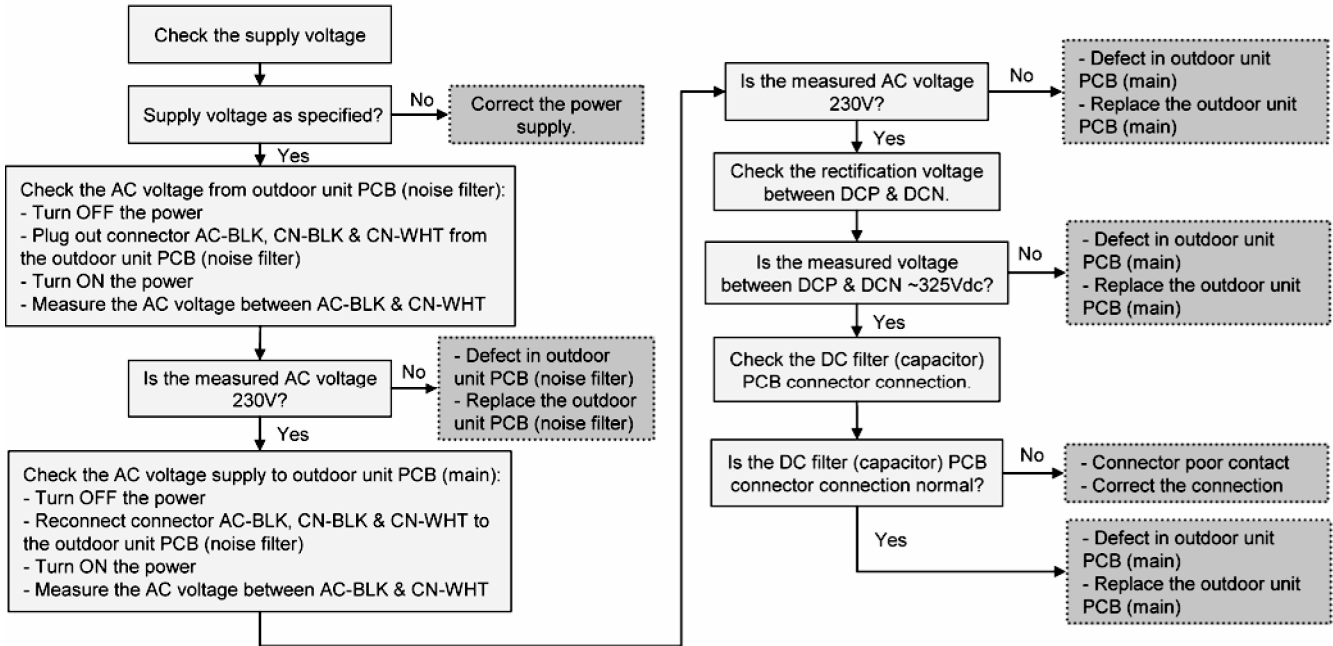

16.5.13 Outdoor High Pressure Protection (H98)

Malfunction Decision Conditions:

During operation of heating, when pressure 4.0 MPa and above is detected by outdoor high pressure sensor.

Malfunction Caused:

- 1 Faulty water pump.
- 2 Insufficient water flow rate in system.
- 3 Water leak in system.
- 4 2/3 way closed.
- 5 Clogged expansion valve or strainer.
- 6 Excessive refrigerant.
- 7 Faulty outdoor high pressure sensor.
- 8 Faulty outdoor unit PCB (main).

Troubleshooting:



Caution

For safety reason and to prevent component breakdown, always switch off the power before remove and connect the component.

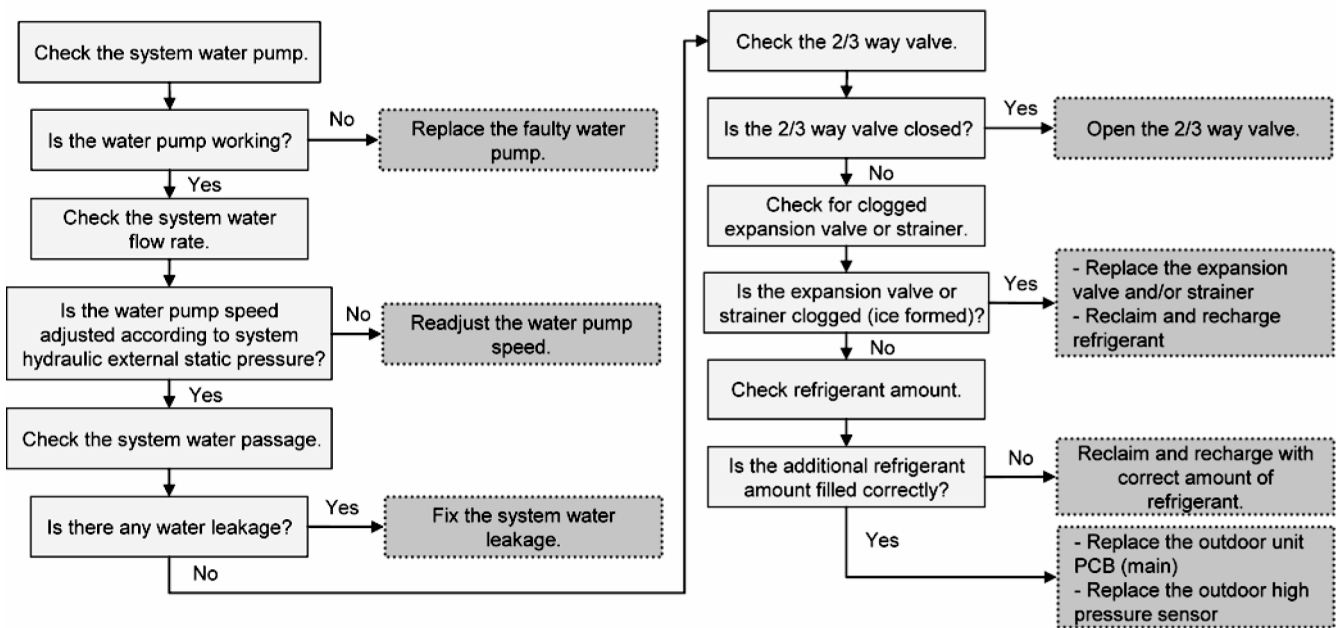

16.5.14 Indoor Freeze-up Protection (H99)

Malfunction Decision Conditions:

During anti-freezing control in cooling operation, when the indoor refrigerant liquid temperature < 0°C.

Malfunction Caused:

- 1 Faulty water pump.
- 2 Insufficient water flow rate in system.
- 3 Water leak in system.
- 4 2 way valve partially closed.
- 5 Clogged expansion valve or strainer.
- 6 Refrigerant shortage (refrigerant leakage).
- 7 Faulty indoor refrigerant liquid temperature sensor.
- 8 Faulty indoor unit PCB (main).

Troubleshooting:



Caution

For safety reason and to prevent component breakdown, always switch off the power before remove and connect the component.

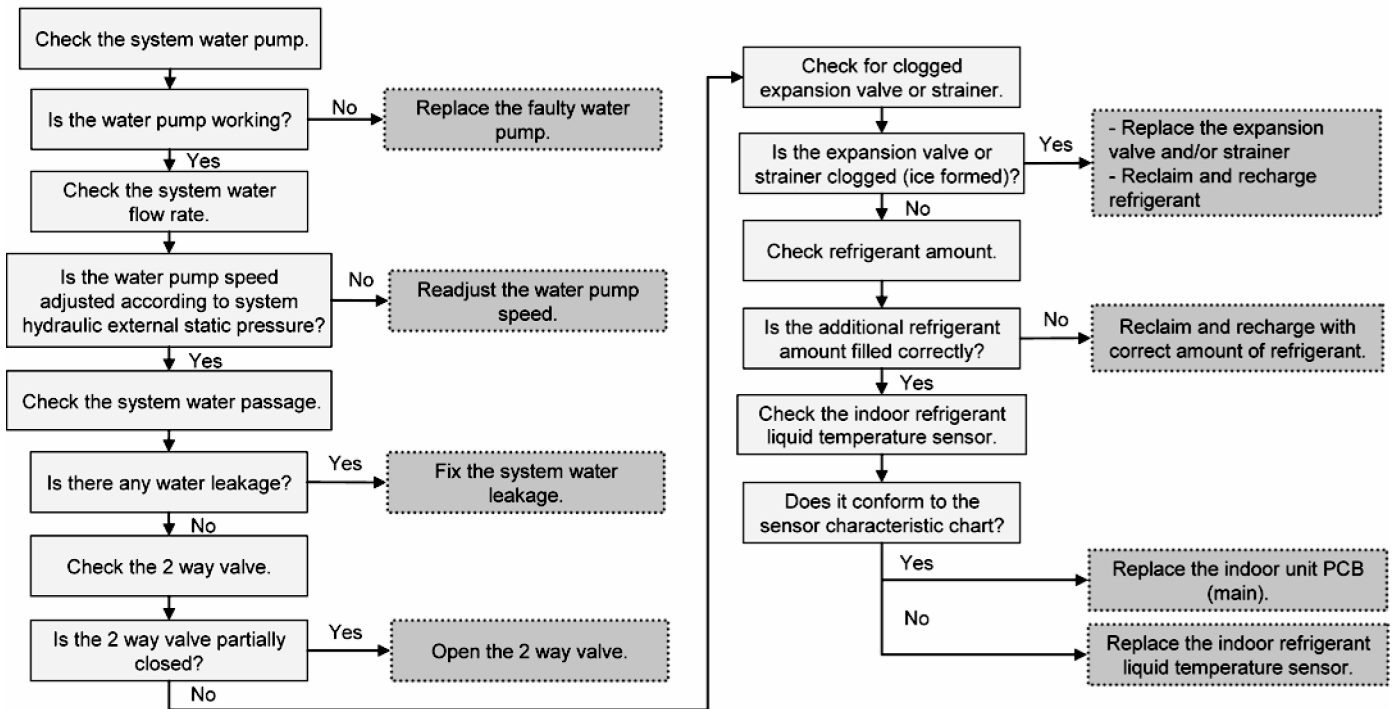

16.5.15 Outdoor High Pressure Switch Activate (F12)

Malfunction Decision Conditions:

During operation of cooling and heating, when pressure 4.5MPa and above is detected by outdoor high pressure switch.

Malfunction Caused:

- 1 Dust accumulation on the outdoor unit heat exchanger.
- 2 Air short circuit at outdoor unit.
- 3 Faulty water pump.
- 4 Insufficient water flow rate in system.
- 5 Water leak in system.
- 6 2/3 way valve closed.
- 7 Clogged expansion valve or strainer.
- 8 Excessive refrigerant.
- 9 Faulty outdoor high pressure sensor and switch.
- 10 Faulty outdoor unit PCB.

Abnormality Judgment:

Continue 4 times in 20 minutes.

Troubleshooting:



Caution

For safety reason and to prevent component breakdown, always switch off the power before remove and connect the component.

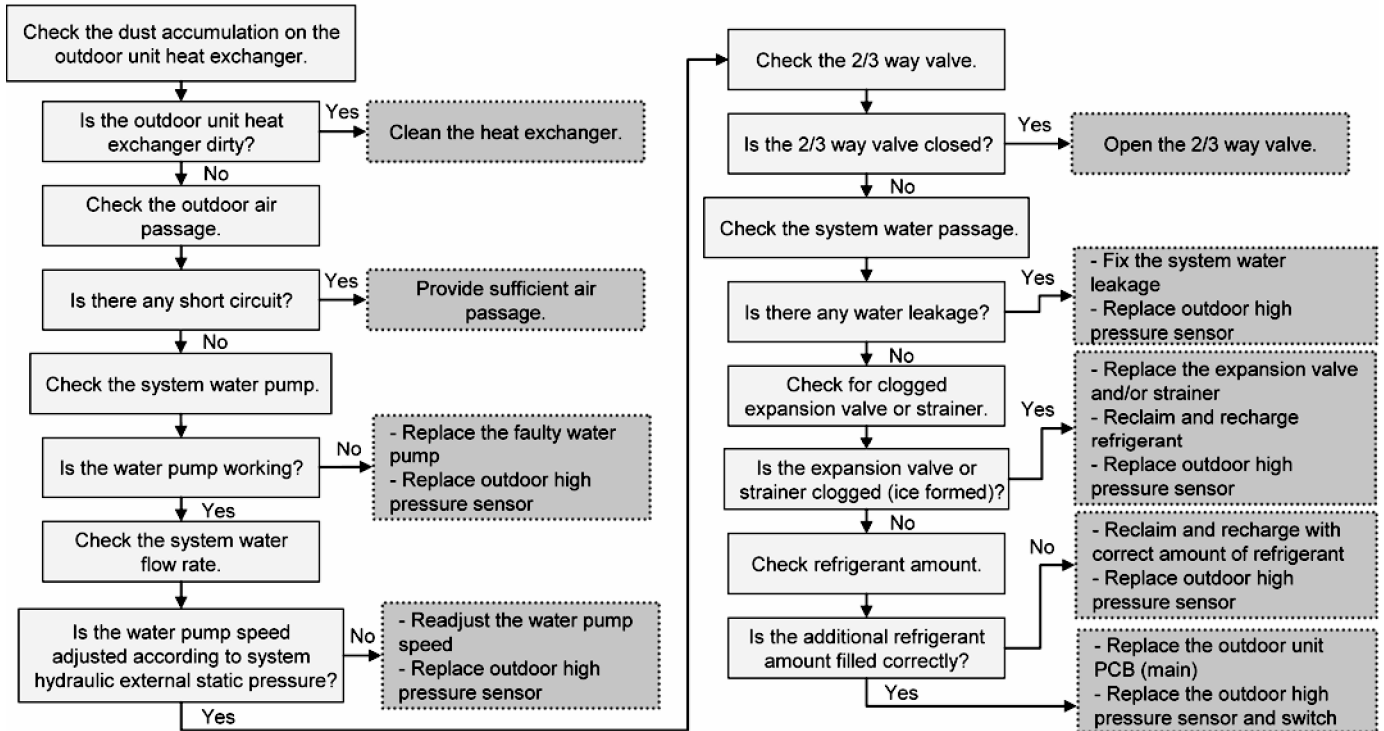

16.5.16 Compressor Rotation Failure (F14)

Malfunction Decision Conditions:

A compressor rotation failure is detected by checking the compressor running condition through the position detection circuit.

Malfunction Caused:

- 1 Compressor terminal disconnect.
- 2 Faulty outdoor unit PCB (main).
- 3 Faulty compressor.

Abnormality Judgment:

Continue 4 times in 20 minutes.

Troubleshooting:



Caution

For safety reason and to prevent component breakdown, always switch off the power before remove and connect the component.

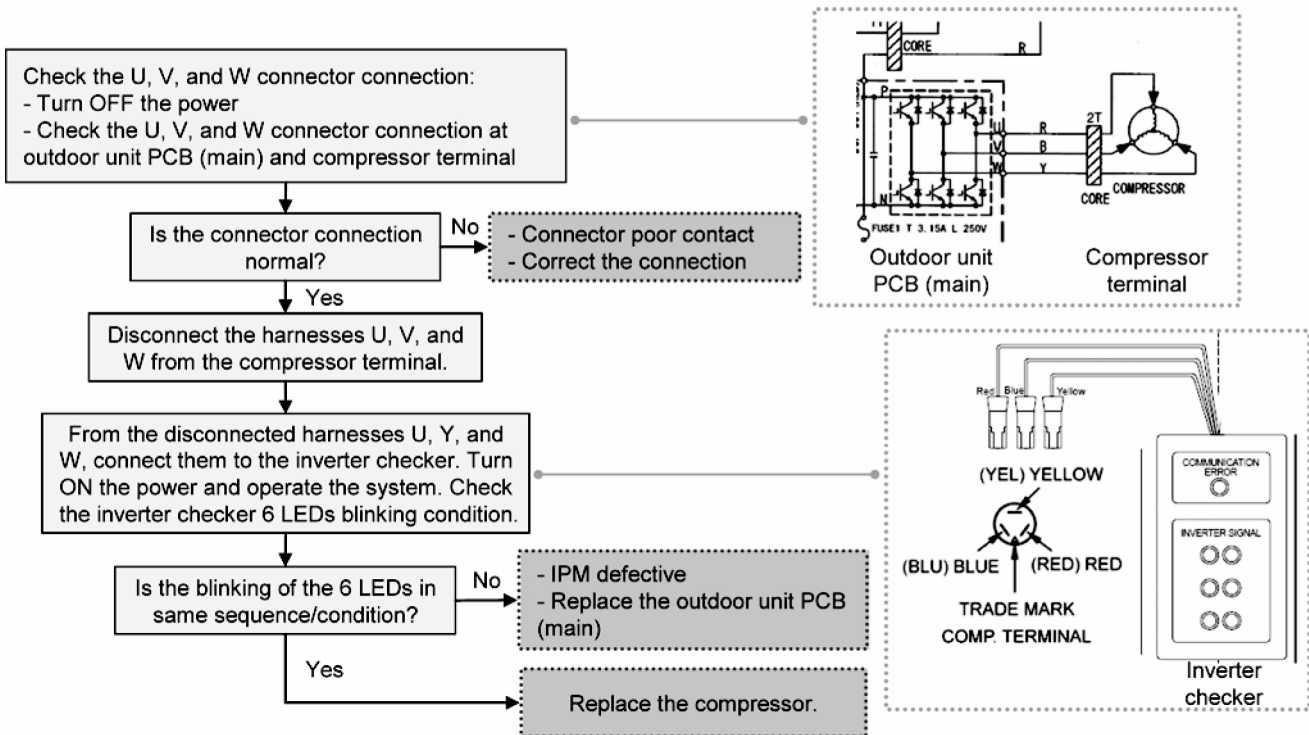

16.5.17 Outdoor Fan Motor (DC Motor) Mechanism Locked (F15)

Malfunction Decision Conditions:

The rotation speed detected by the Hall IC of the fan motor during fan motor operation is used to determine abnormal fan motor (feedback of rotation > 2550rpm or < 50rpm).

Malfunction Caused:

- 1 Operation stop due to short circuit inside the fan motor winding.
- 2 Operation stop due to breaking of wire inside the fan motor.
- 3 Operation stop due to breaking of fan motor lead wires.
- 4 Operation stop due to fan motor Hall IC malfunction.
- 5 Operation error due to faulty outdoor unit PCB.

Abnormality Judgment:

Continue 2 times in 30 minutes.

Troubleshooting:



Caution

For safety reason and to prevent component breakdown, always switch off the power before remove and connect the component.

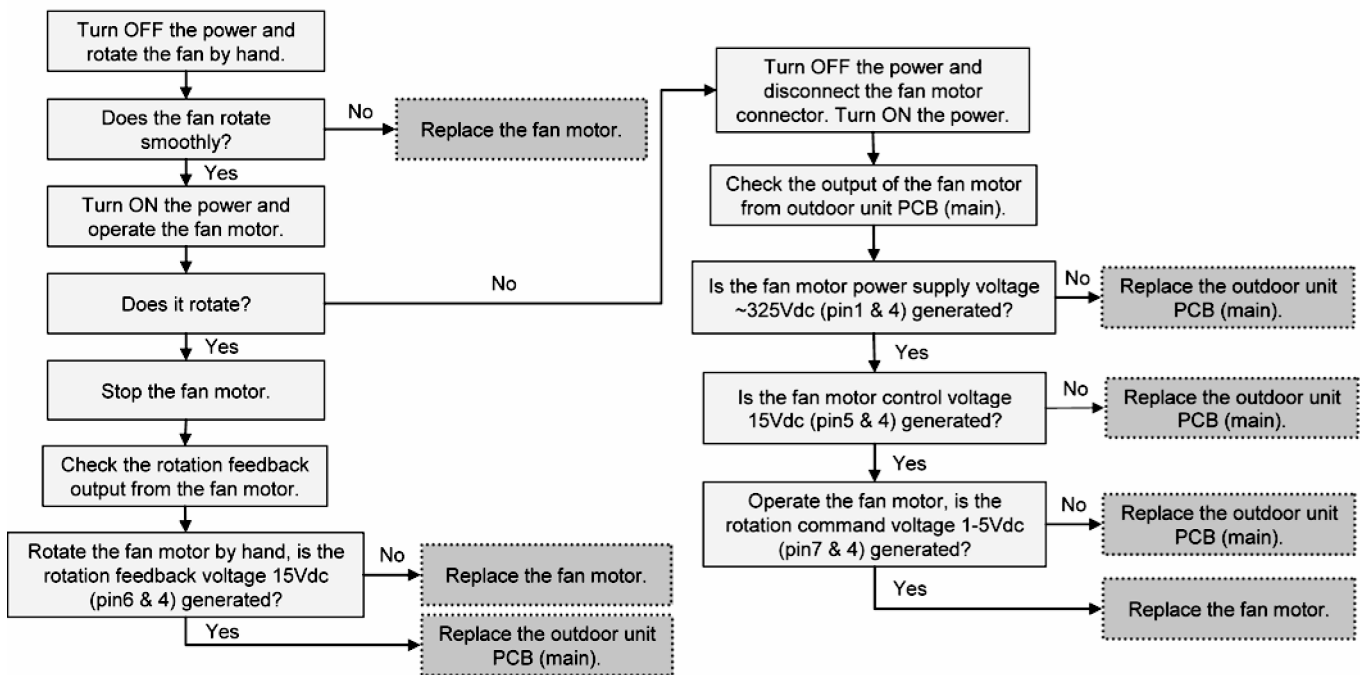

16.5.18 Input Over Current Detection (F16)

Malfunction Decision Conditions:

During operation of cooling and heating, when outdoor current above 27.9A is detected by the current transformer (CT) in the outdoor unit PCB.

Malfunction Caused:

- 1 Excessive refrigerant.
- 2 Faulty outdoor unit PCB (main).

Abnormality Judgment:

Continue 3 times in 20 minutes.

Troubleshooting: Caution

For safety reason and to prevent component breakdown, always switch off the power before remove and connect the component.

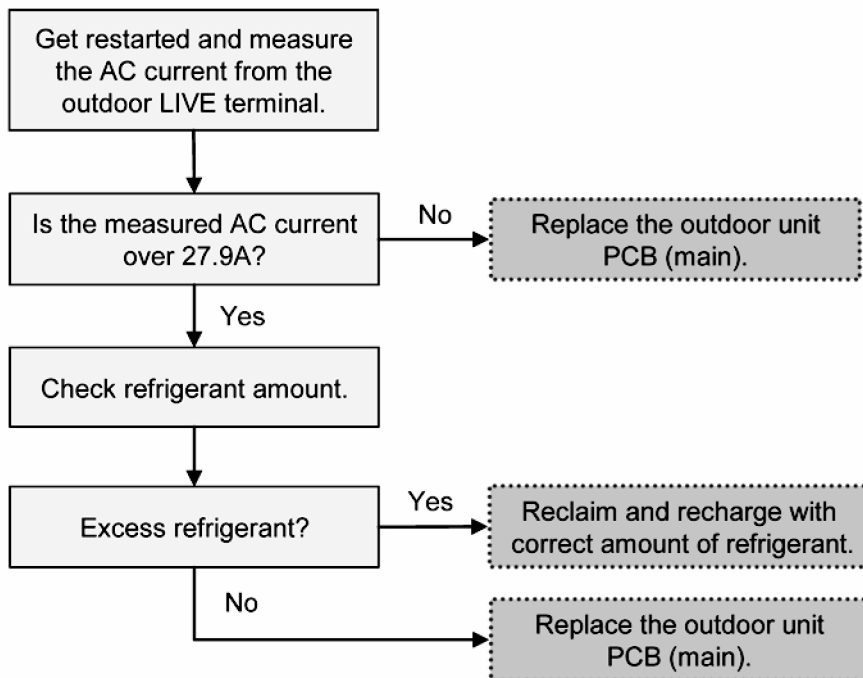

16.5.19 Compressor Overheating (F20)

Malfunction Decision Conditions:

During operation of cooling and heating, when temperature above 112°C is detected by the compressor tank temperature sensor.

Malfunction Caused:

- 1 Faulty compressor tank temperature sensor.
- 2 2/3 way valve closed.
- 3 Refrigerant shortage (refrigerant leakage).
- 4 Clogged expansion valve or strainer.
- 5 Faulty outdoor unit PCB (main).
- 6 Faulty compressor.

Abnormality Judgment:

Continue 4 times in 30 minutes.

Troubleshooting:



Caution

For safety reason and to prevent component breakdown, always switch off the power before remove and connect the component.

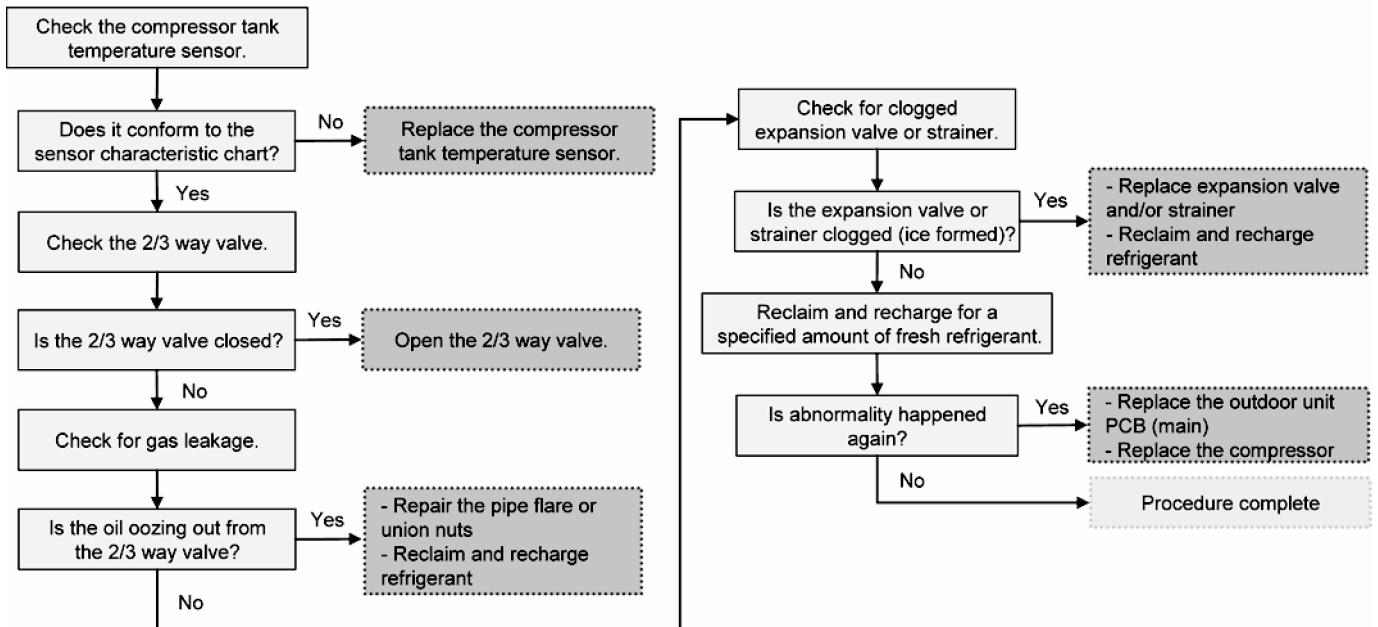

16.5.20 IPM Overheating (F22)

Malfunction Decision Conditions:

During operation of cooling and heating, when temperature 95°C is detected by the outdoor IPM temperature sensor.

Malfunction Caused:

- 1 Faulty outdoor unit fan motor.
- 2 Faulty outdoor unit PCB (main).

Abnormality Judgment:

Continue 3 times in 30 minutes.

Troubleshooting: **Caution**

For safety reason and to prevent component breakdown, always switch off the power before remove and connect the component.

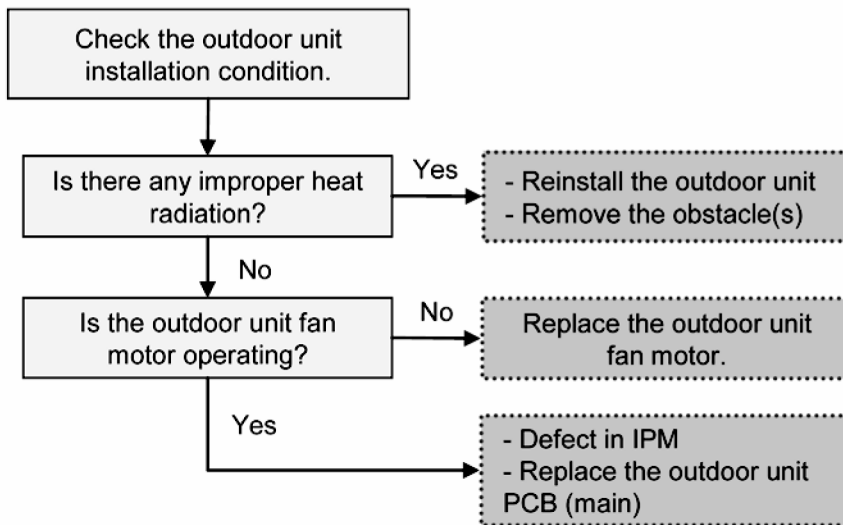

16.5.21 Output Over Current Detection (F23)

Malfunction Decision Conditions:

During operation of cooling and heating, when outdoor DC current is above $40.1 \pm 5.0A$ (for: UD07~09CE) OR $44.7 \pm 5.0A$ (for: UD12~16CE) is detected by the IPM DC Peak sensing circuitry in the outdoor unit PCB (main).

Malfunction Caused:

- 1 Faulty outdoor unit PCB (main).
- 2 Faulty compressor.

Abnormality Judgment:

Continue for 7 times.

Troubleshooting:



Caution

For safety reason and to prevent component breakdown, always switch off the power before remove and connect the component.

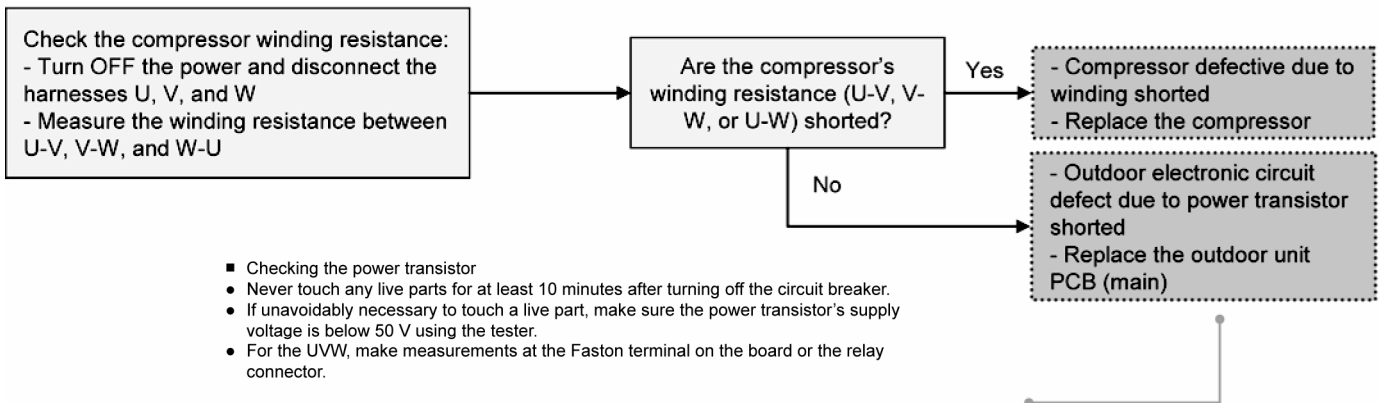

Tester's negative terminal	Power transistor (+)	UVW	Power transistor (-)	UVW
Tester's positive terminal	UVW	Power transistor (+)	UVW	Power transistor (-)
Normal resistance	Several kohms to several Mohms			
Abnormal resistance	0 or ∞			

16.5.22 Refrigeration Cycle Abnormality (F24)

Malfunction Decision Conditions:

- 1 During operation of cooling and heating, compressor frequency > Frated.
- 2 During operation of cooling and heating, running current: $0.65A < I < 1.65A$.
- 3 During operation of cooling, water inlet temperature - indoor refrigerant liquid temperature < 5°C.
- 4 During operation of heating, indoor refrigerant liquid temperature - water inlet temperature < 5°C.

Malfunction Caused:

- 1 Faulty water inlet or indoor refrigerant liquid temperature sensors.
- 2 2/3 way valve closed.
- 3 Refrigerant shortage (refrigerant leakage).
- 4 Clogged expansion valve or strainer.
- 5 Faulty outdoor unit PCB (main).
- 6 Poor compression of compressor.

Abnormality Judgment:

Continue 2 times in 20 minutes.

Troubleshooting:



For safety reason and to prevent component breakdown, always switch off the power before remove and connect the component.

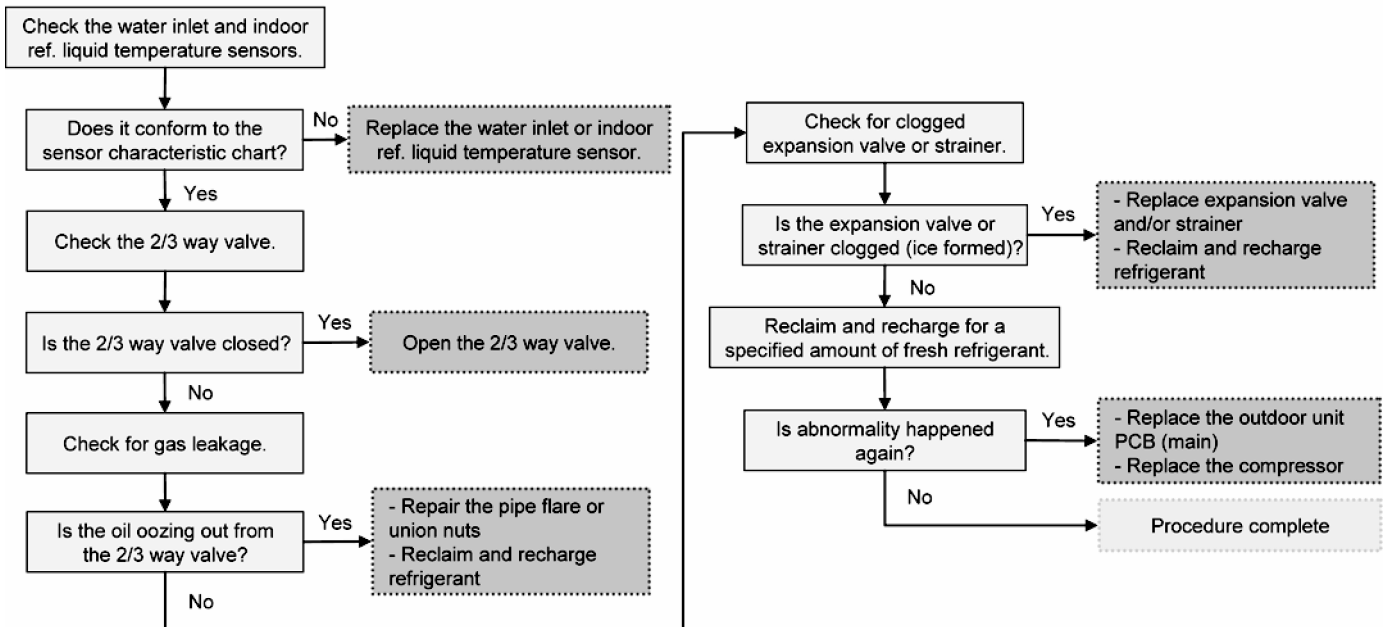

16.5.23 Four Way Valve Abnormality (F25)

Malfunction Decision Conditions:

- 1 During heating operation, when the indoor pipe temperature of thermostat ON indoor unit < 0°C.
- 2 During cooling operation, when the indoor pipe temperature of thermostat ON indoor unit > 45°C.

Malfunction Caused:

- 1 Faulty sensor.
- 2 Faulty connector connection.
- 3 Faulty outdoor unit PCB (noise filter/main).
- 4 Faulty four way valve.

Abnormality Judgment:

Continue 4 times in 30 minutes.

Troubleshooting:



Caution

For safety reason and to prevent component breakdown, always switch off the power before remove and connect the component.

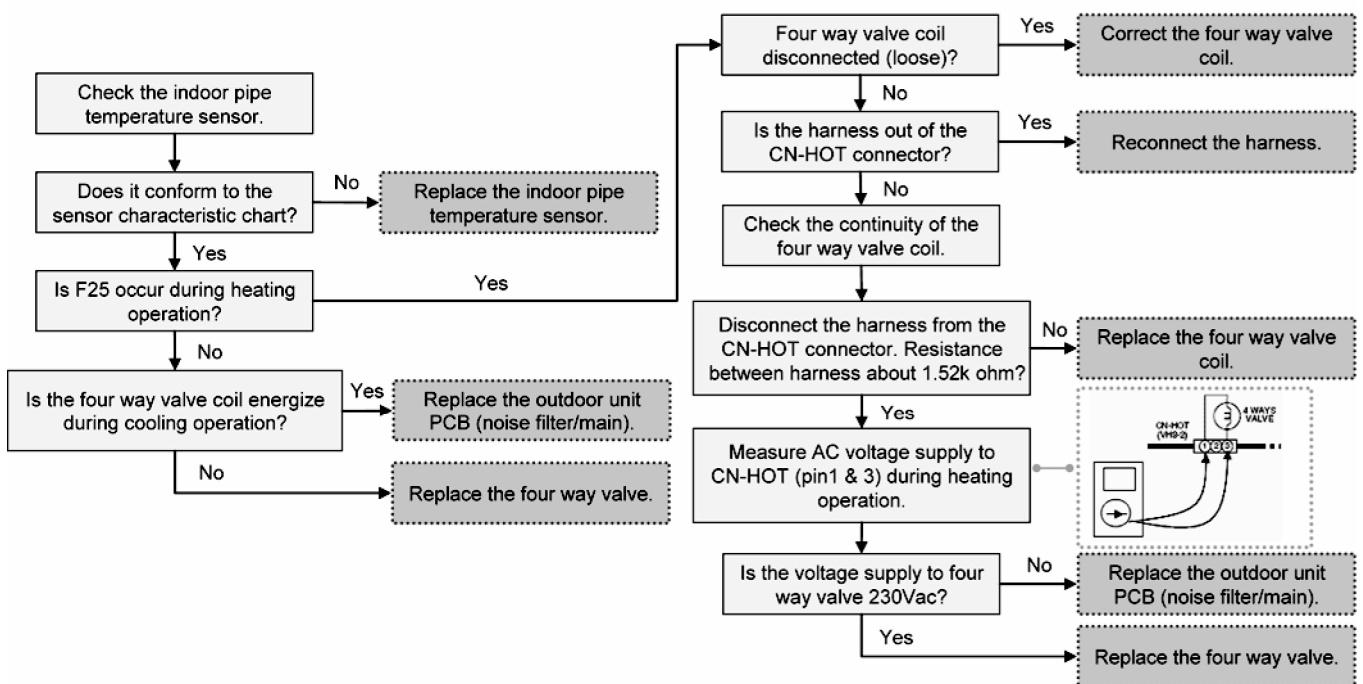

16.5.24 Outdoor High Pressure Switch Abnormal (F27)

Malfunction Decision Conditions:

During compressor stop, and outdoor high pressure switch is remain opened.

Malfunction Caused:

- 1 Faulty connector connection.
- 2 Faulty switch.
- 3 Faulty outdoor unit PCB (main).

Abnormality Judgment:

Continue for 1 minute.

Troubleshooting:



Caution

For safety reason and to prevent component breakdown, always switch off the power before remove and connect the component.

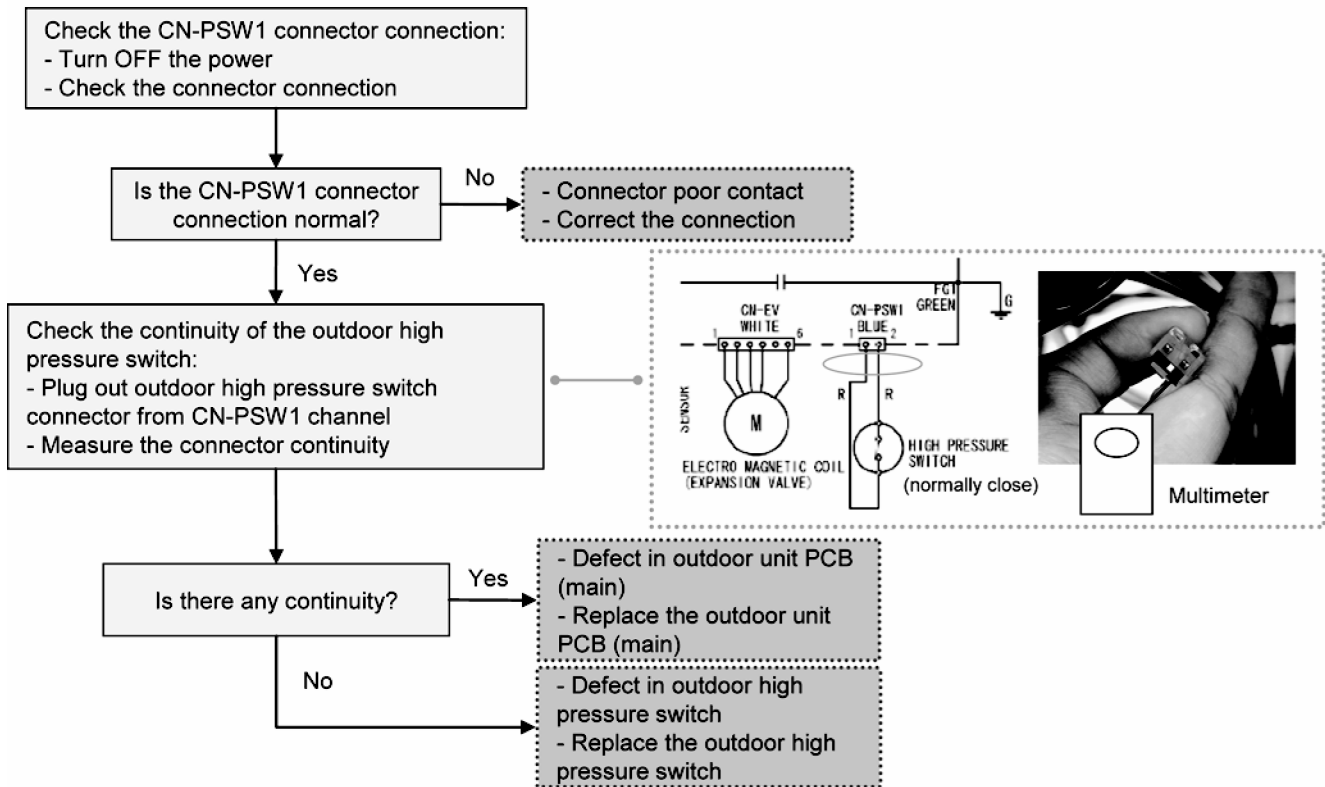

16.5.25 Outdoor Air Temperature Sensor Abnormality (F36)

Malfunction Decision Conditions:

During startup and operation of cooling and heating, the temperatures detected by the outdoor air temperature sensor are used to determine sensor error.

Malfunction Caused:

- 1 Faulty connector connection.
- 2 Faulty sensor.
- 3 Faulty outdoor unit PCB (main).

Abnormality Judgment:

Continue for 5 seconds.

Troubleshooting:



Caution

For safety reason and to prevent component breakdown, always switch off the power before remove and connect the component.

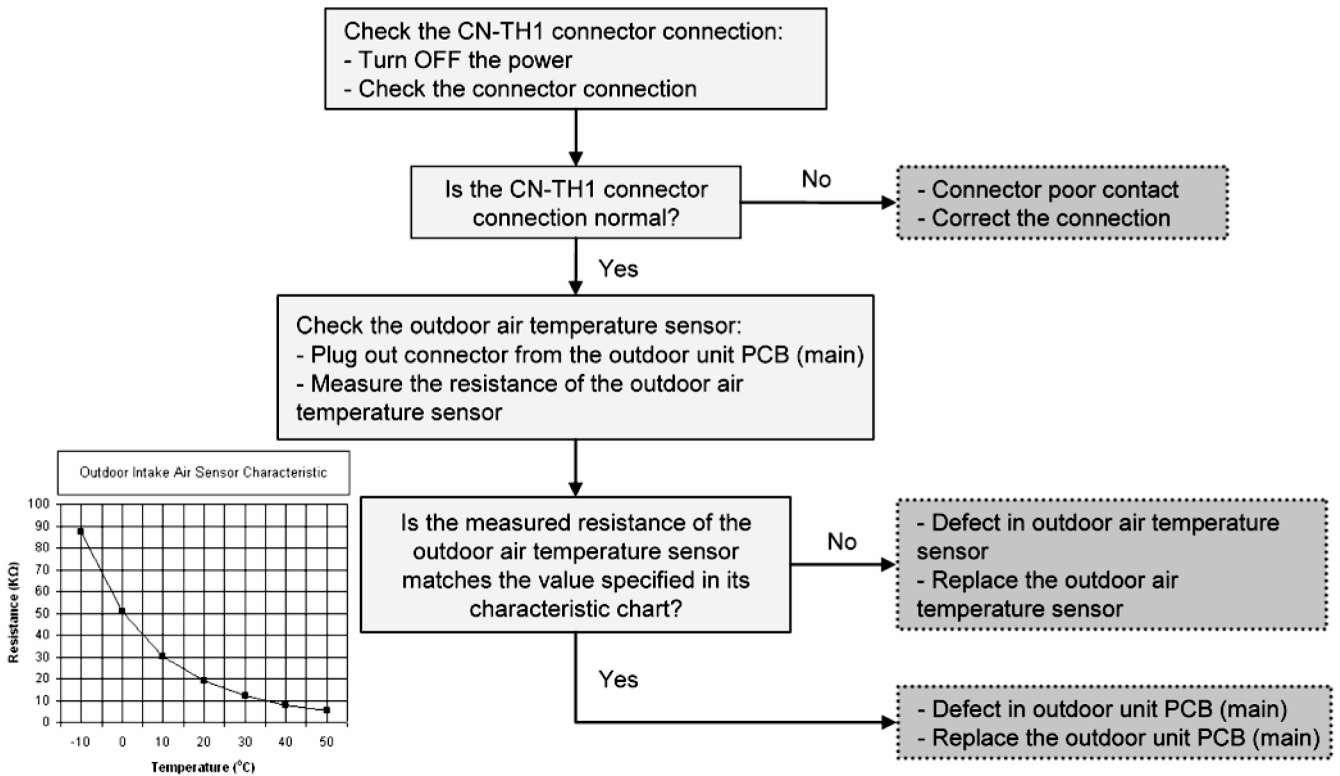

16.5.26 Indoor Water Inlet Temperature Sensor Abnormality (F37)

Malfunction Decision Conditions:

During startup and operation of cooling and heating, the temperatures detected by the indoor water inlet temperature sensor are used to determine sensor error.

Malfunction Caused:

- 1 Faulty connector connection.
- 2 Faulty sensor.
- 3 Faulty indoor unit PCB (main).

Abnormality Judgment:

Continue for 5 seconds.

Troubleshooting:



Caution

For safety reason and to prevent component breakdown, always switch off the power before remove and connect the component.

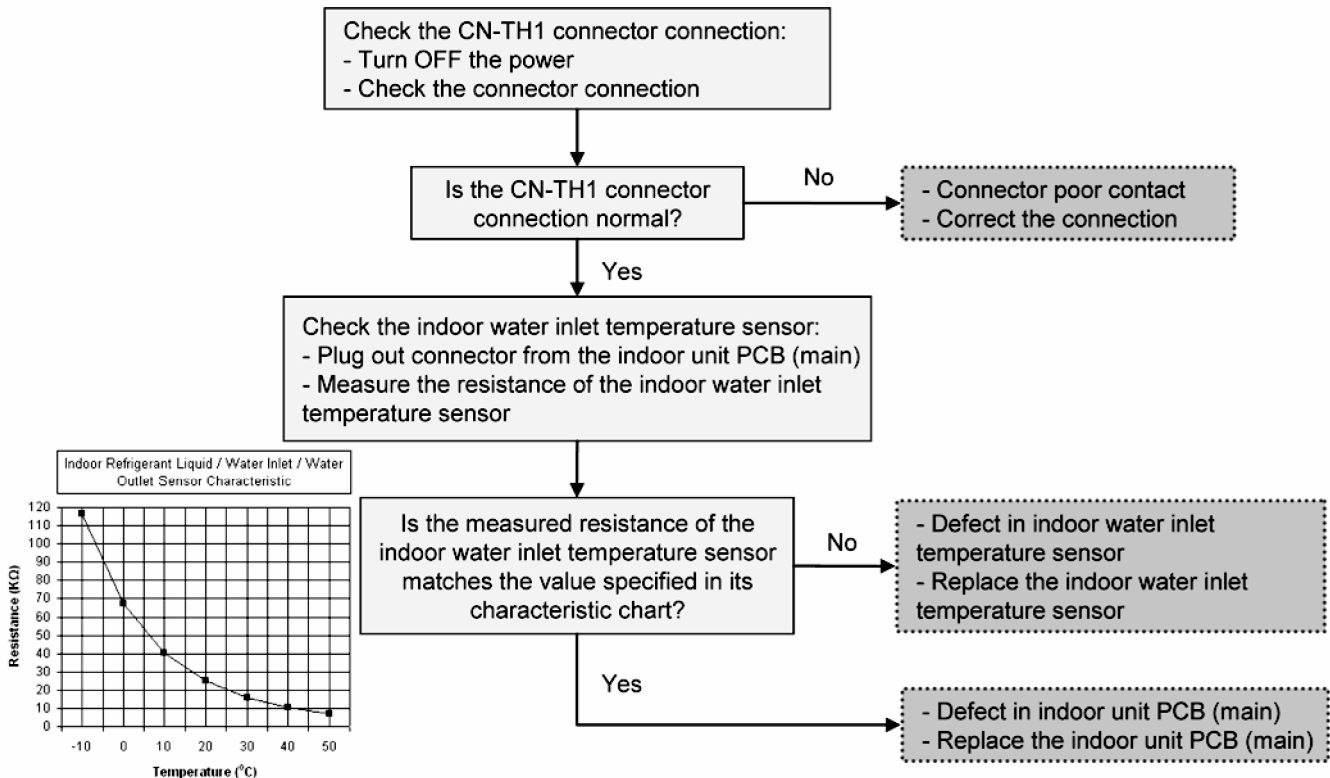

16.5.27 Outdoor Discharge Pipe Temperature Sensor Abnormality (F40)

Malfunction Decision Conditions:

During startup and operation of cooling and heating, the temperatures detected by the outdoor discharge pipe temperature sensor are used to determine sensor error.

Malfunction Caused:

- 1 Faulty connector connection.
- 2 Faulty sensor.
- 3 Faulty outdoor unit PCB (main).

Abnormality Judgment:

Continue for 5 seconds.

Troubleshooting:



Caution

For safety reason and to prevent component breakdown, always switch off the power before remove and connect the component.

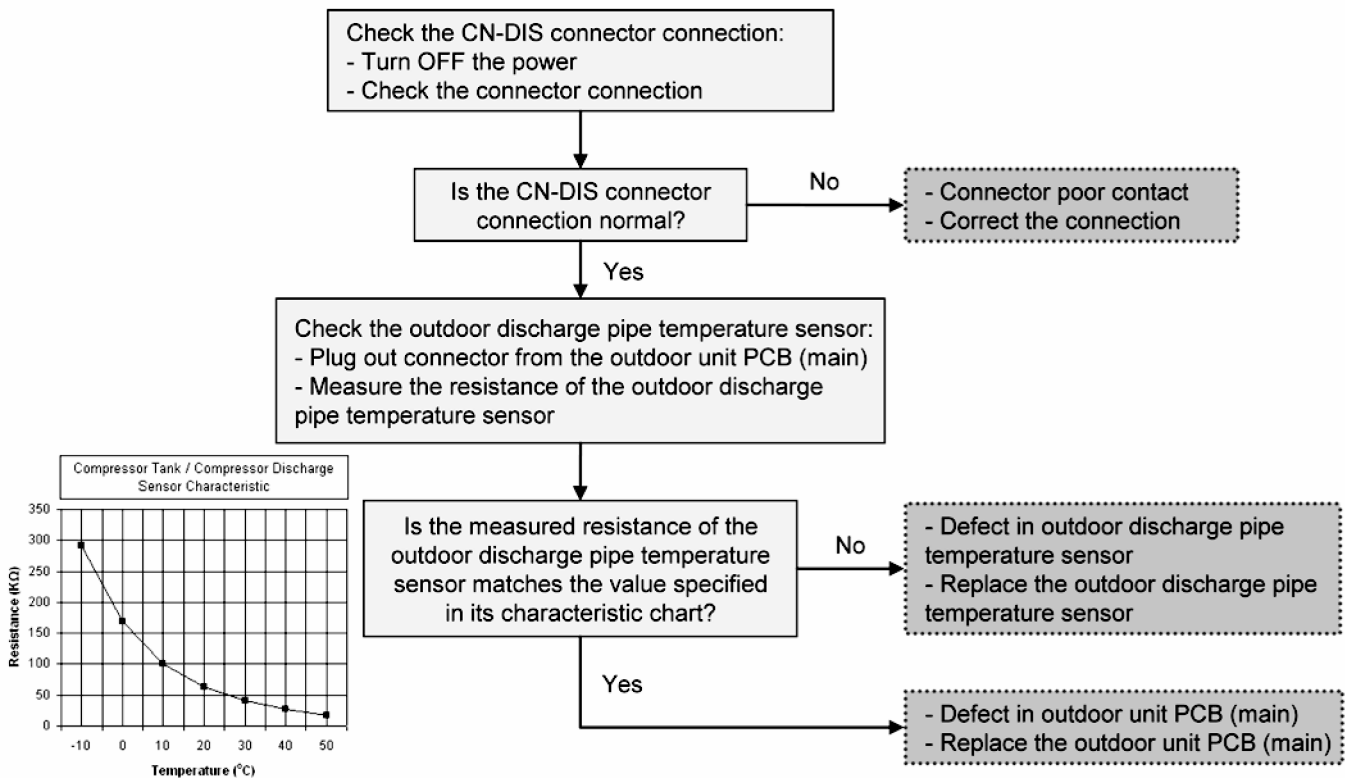

16.5.28 Power Factor Correction (PFC) Abnormality (F41)

Malfunction Decision Conditions:

During operation of cooling and heating, when the PFC protection circuitry in the outdoor unit PCB (main) senses abnormal high DC voltage level.

Malfunction Caused:

- 1 Power supply surge.
- 2 Compressor windings not uniform.
- 3 Faulty outdoor unit PCB (main).

Abnormality Judgment:

Continue 4 times in 10 minutes.

Troubleshooting:



Caution

For safety reason and to prevent component breakdown, always switch off the power before remove and connect the component.

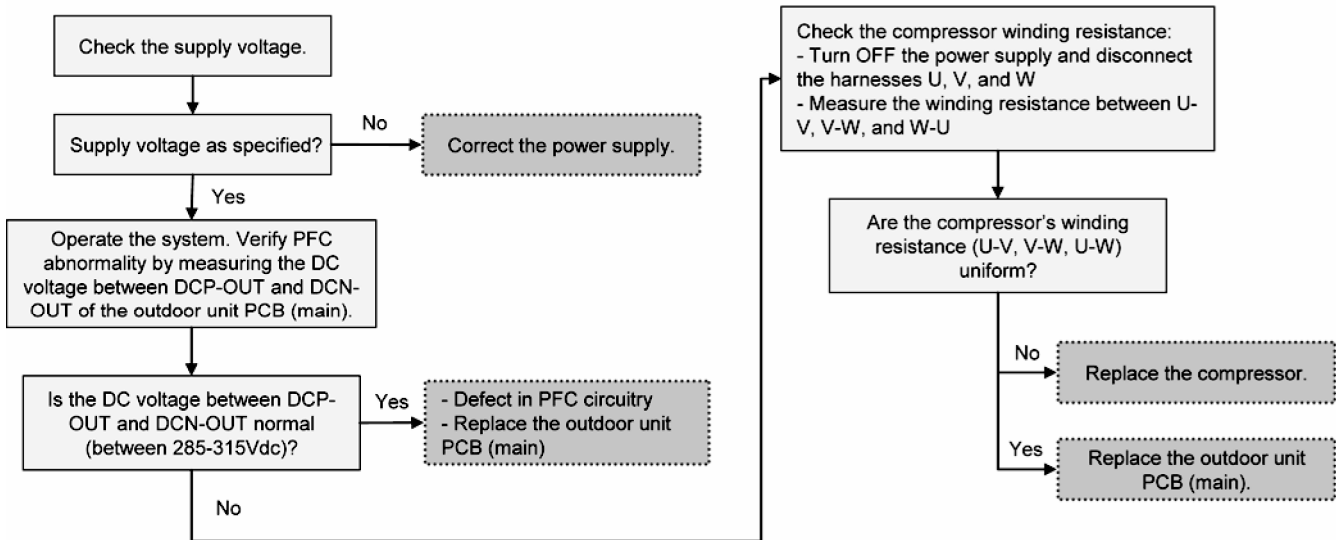

16.5.29 Outdoor Pipe Temperature Sensor Abnormality (F42)

Malfunction Decision Conditions:

During startup and operation of cooling and heating, the temperatures detected by the outdoor pipe temperature sensor are used to determine sensor error.

Malfunction Caused:

- 1 Faulty connector connection.
- 2 Faulty sensor.
- 3 Faulty outdoor unit PCB (main).

Abnormality Judgment:

Continue for 5 seconds.

Troubleshooting:



Caution

For safety reason and to prevent component breakdown, always switch off the power before remove and connect the component.

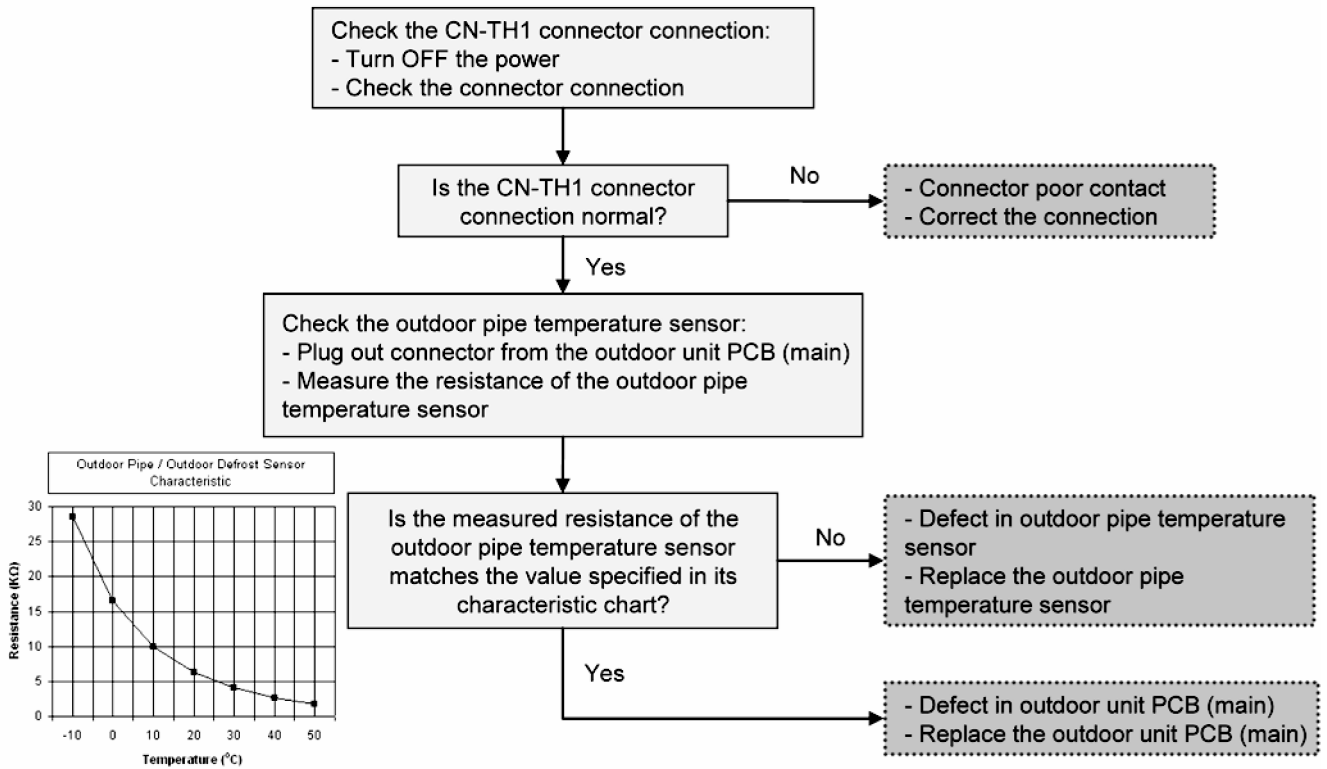

16.5.30 Outdoor Defrost Temperature Sensor Abnormality (F43)

Malfunction Decision Conditions:

During startup and operation of cooling and heating, the temperatures detected by the outdoor defrost temperature sensor are used to determine sensor error.

Malfunction Caused:

- 1 Faulty connector connection.
- 2 Faulty sensor.
- 3 Faulty outdoor unit PCB (main).

Abnormality Judgment:

Continue for 5 seconds.

Troubleshooting:



Caution

For safety reason and to prevent component breakdown, always switch off the power before remove and connect the component.

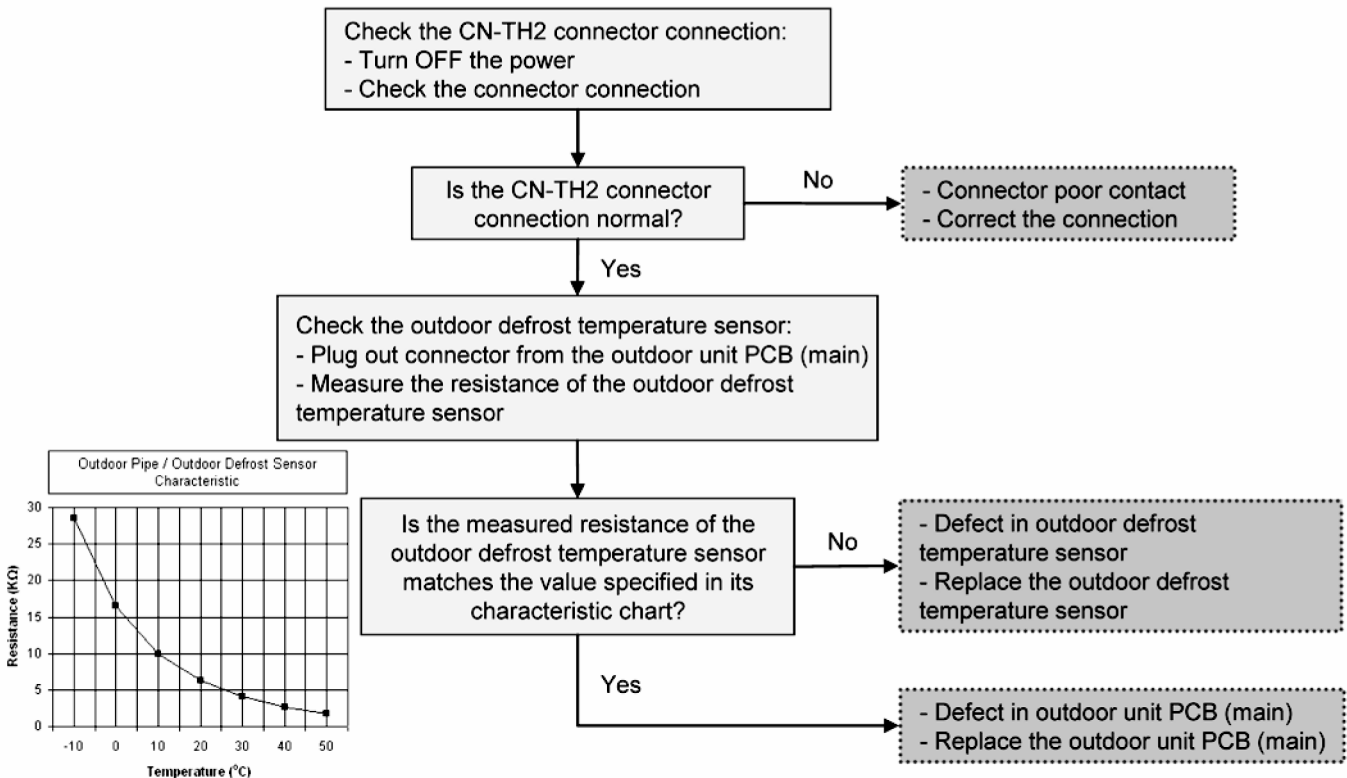

16.5.31 Indoor Water Outlet Temperature Sensor Abnormality (F45)

Malfunction Decision Conditions:

During startup and operation of cooling and heating, the temperatures detected by the indoor water outlet temperature sensor are used to determine sensor errors.

Malfunction Caused:

- 1 Faulty connector connection.
- 2 Faulty sensor.
- 3 Faulty indoor unit PCB (main).

Abnormality Judgment:

Continue for 5 seconds.

Troubleshooting:



Caution

For safety reason and to prevent component breakdown, always switch off the power before remove and connect the component.

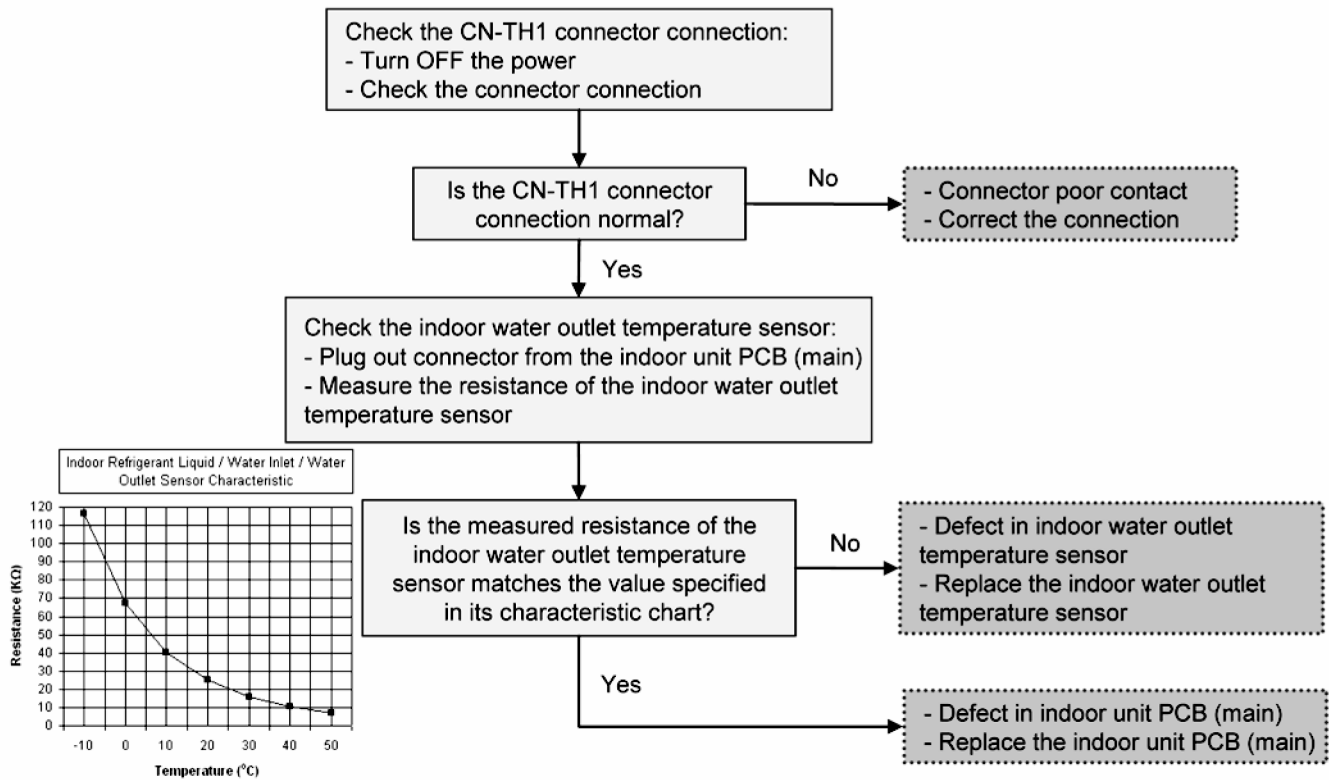

16.5.32 Outdoor Current Transformer Open Circuit (F46)

Malfunction Decision Conditions:

A current transformer (CT) open circuit is detected by checking the compressor running frequency (\geq rated frequency) and CT detected input current ($< 0.65A$) for continuously 20 seconds.

Malfunction Caused:

- 1 CT defective.
- 2 Faulty outdoor unit PCB.
- 3 Compressor defective (low compression).

Abnormality Judgment:

Continue 3 times in 20 seconds.

Troubleshooting:



Caution

For safety reason and to prevent component breakdown, always switch off the power before remove and connect the component.

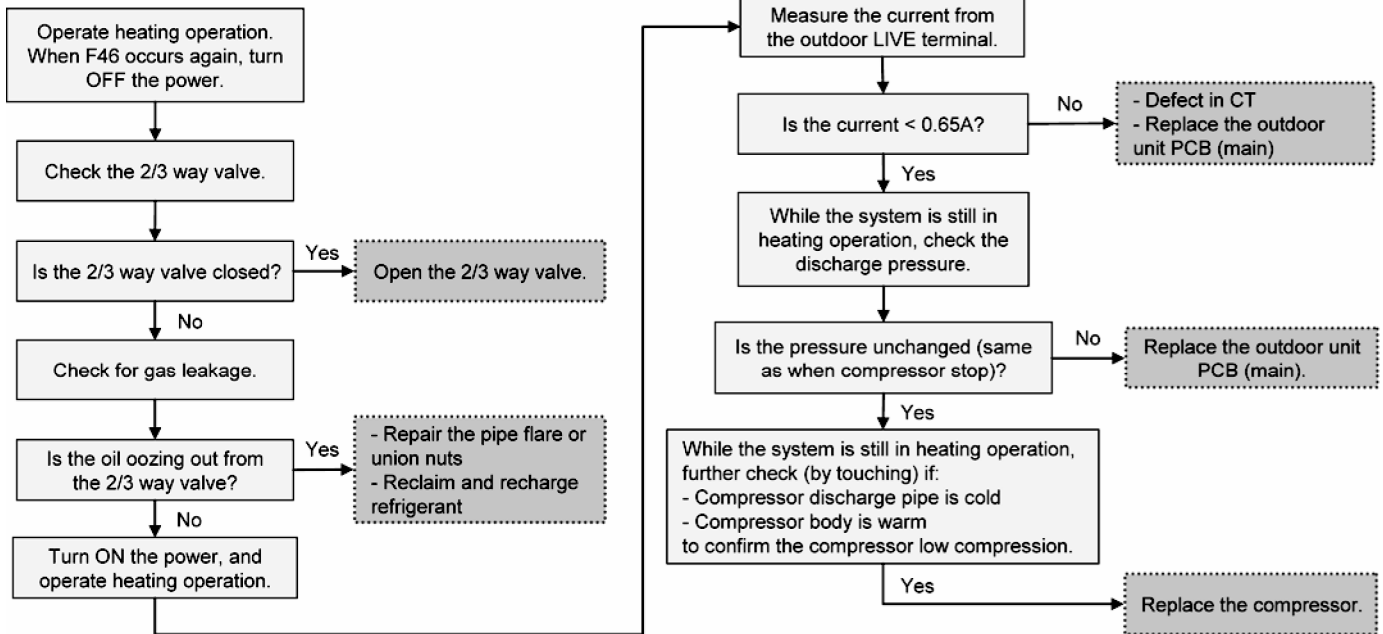

16.5.33 Cooling High Pressure Overload Protection (F95)

Malfunction Decision Conditions:

During operation of cooling, when pressure 4.0MPa and above is detected by outdoor high pressure sensor.

Malfunction Caused:

- 1 Dust accumulation in the outdoor unit heat exchanger.
- 2 Air short circuit at outdoor unit.
- 3 2 way valve closed.
- 4 Faulty outdoor unit fan motor.
- 5 Clogged expansion valve or strainer.
- 6 Excessive refrigerant.
- 7 Faulty outdoor high pressure sensor.
- 8 Faulty outdoor unit PCB (main).

Troubleshooting:



Caution

For safety reason and to prevent component breakdown, always switch off the power before remove and connect the component.

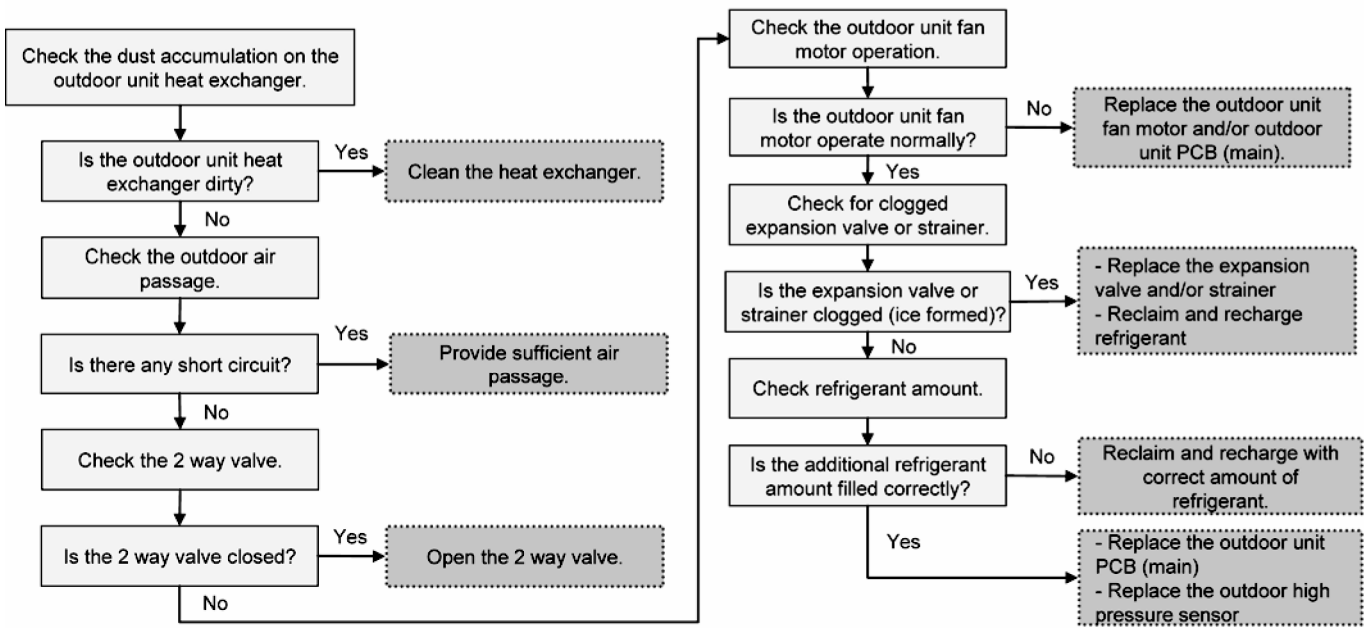

17. Disassembly and Assembly Instructions

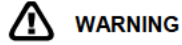

High Voltage are generated in the electrical parts area by the capacitor. Ensure that the capacitor has discharged sufficiently before proceeding with repair work. Failure to heed this caution may result in electric shocks.

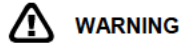

Be sure to switch off all the power supply before performing each of the below action.

17.1 To Remove The Cabinet Front Plate

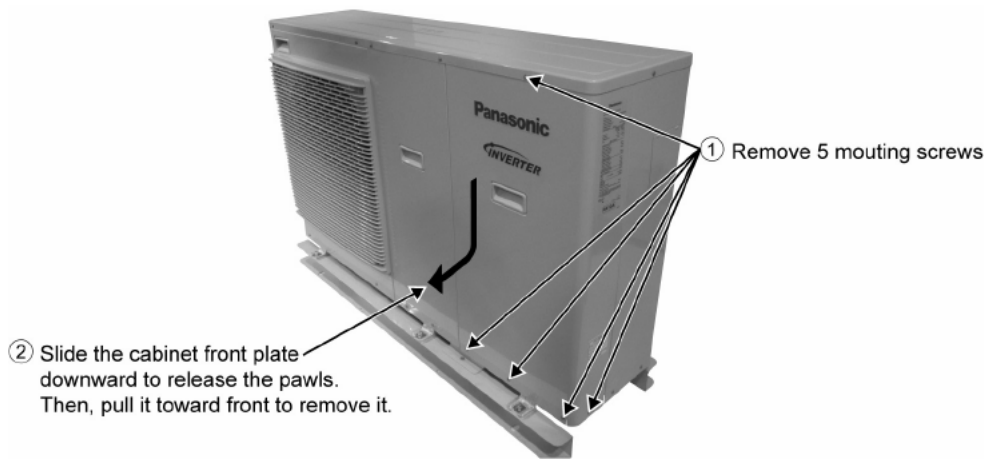

17.2 To Remove The Cabinet Top Plate

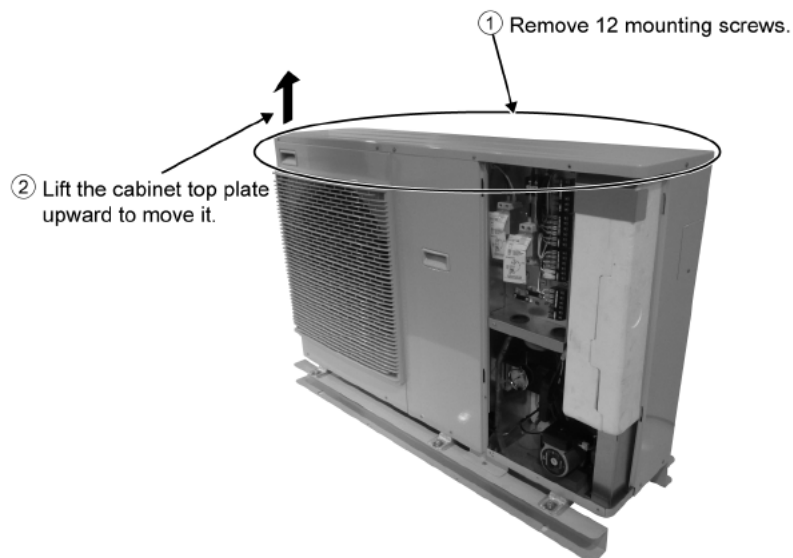

17.3 To Remove The Cabinet Rear Plate

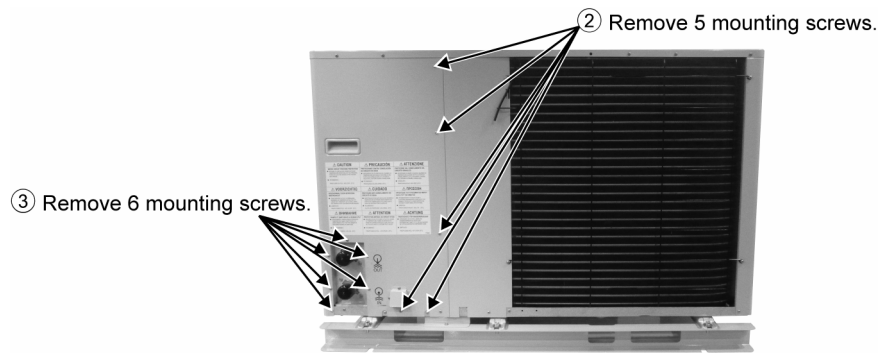
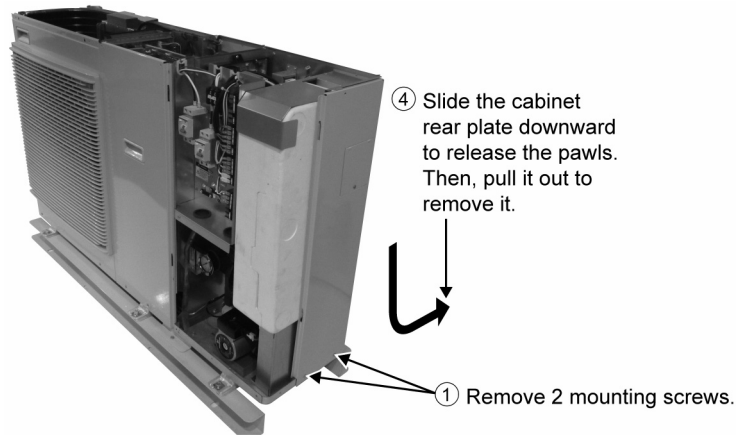

17.4 To Remove Pressure Gauge

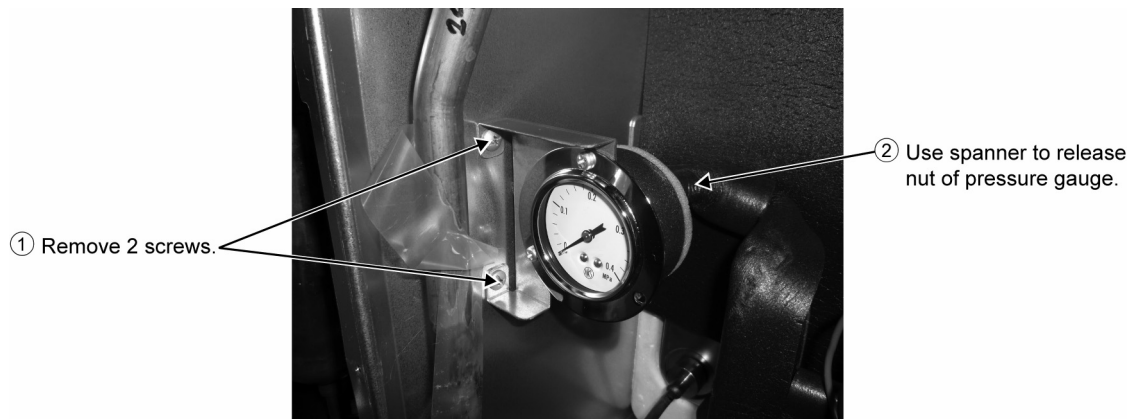

17.5 To Remove RCCB

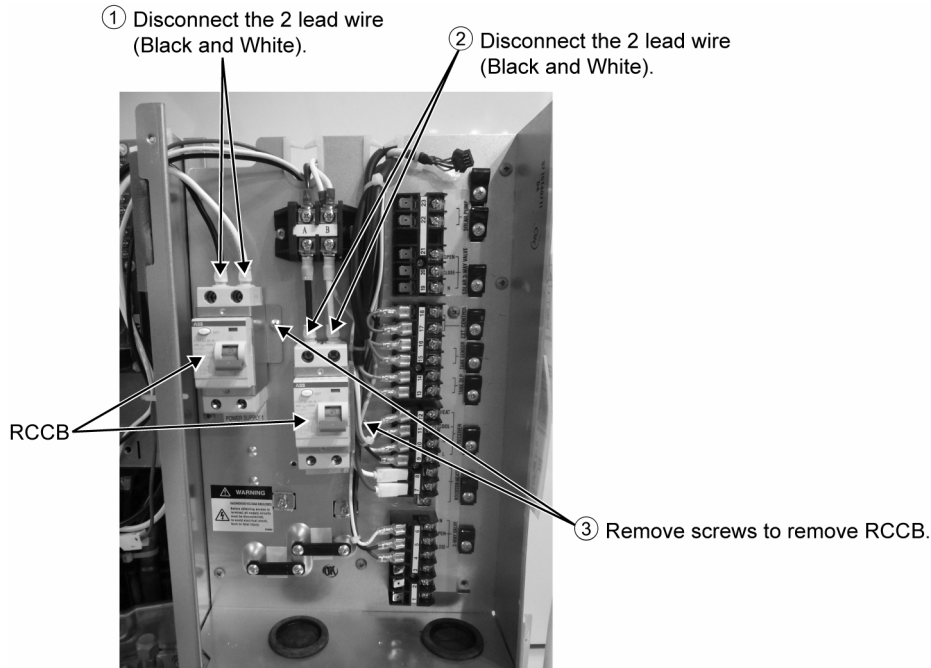

17.6 To Remove Transformer and Electronic Controller Board

- ① Disconnect the 2 lead wire T1, T2 (Black) and connector CN-T1 (Red) from the Electronic Controller board.

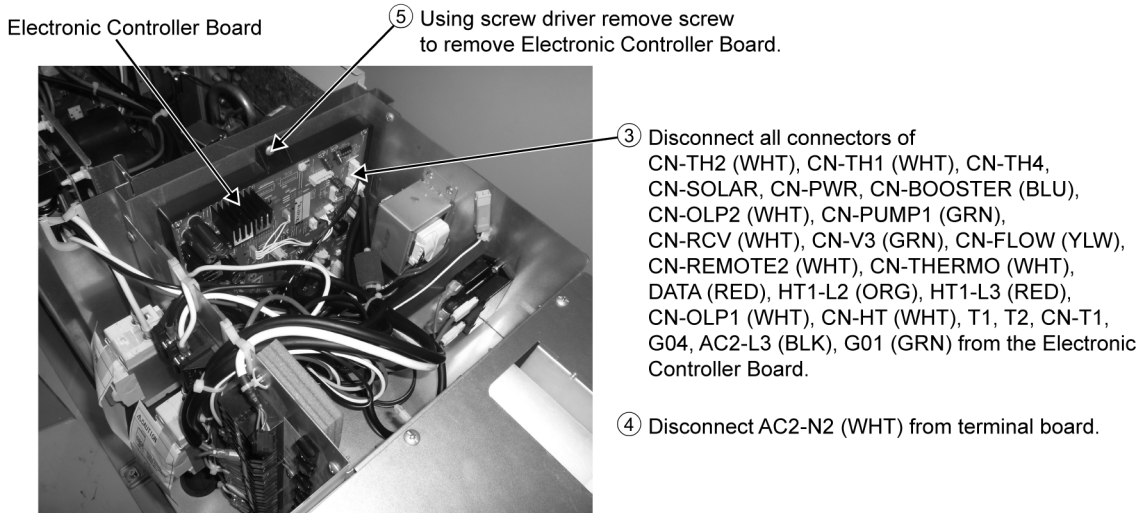
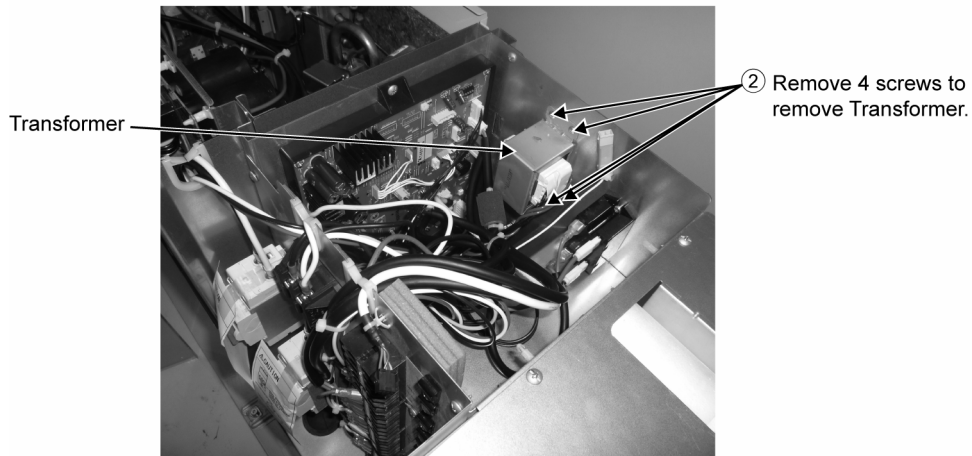

17.7 To Remove Pressure Relief Valve

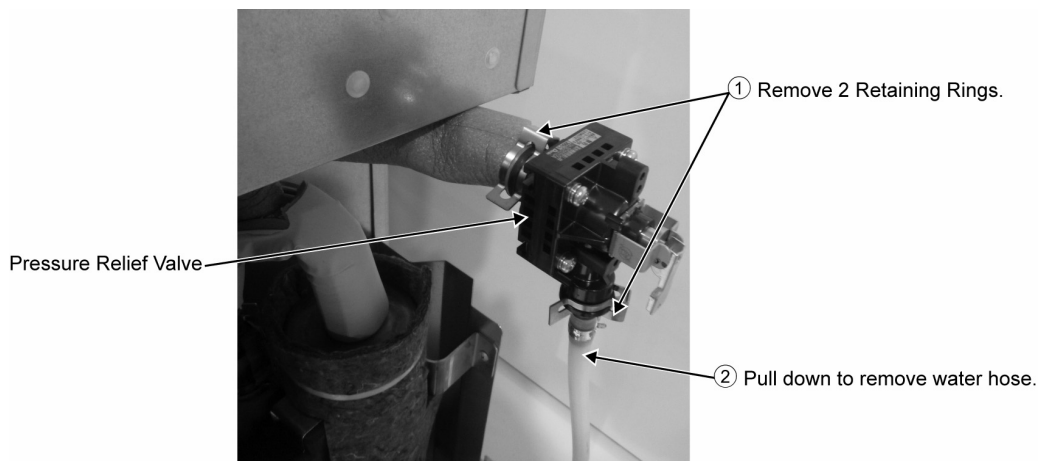

⚠ When reinstall the water pipe, use grease or water at the joining.

17.8 To Remove Flow Switch



① Disconnect the connector of CN-FLOW from the Electronic Controller Board.

⚠ When reinstall the water pipe, use grease or water at the joining.

17.9 To Remove Water Pump

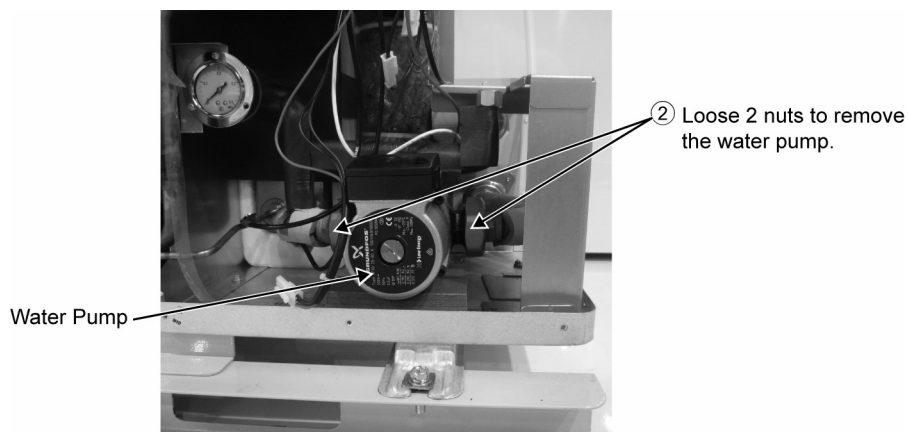

① Disconnect the connector of water pump.

⚠ When reinstall the water pipe, use grease or water at the joining.

18. Technical Data

18.1 Operation Characteristics

18.1.1 WH-MDF06D3E5

Heating Characteristics at Different Outdoor Air Temperature

Condition

Outdoor air temperature : 7°C (DBT), 6°C (WBT)

Indoor water inlet temperature : 30°C

Indoor water outlet temperature : 35°C

Piping length : 7m

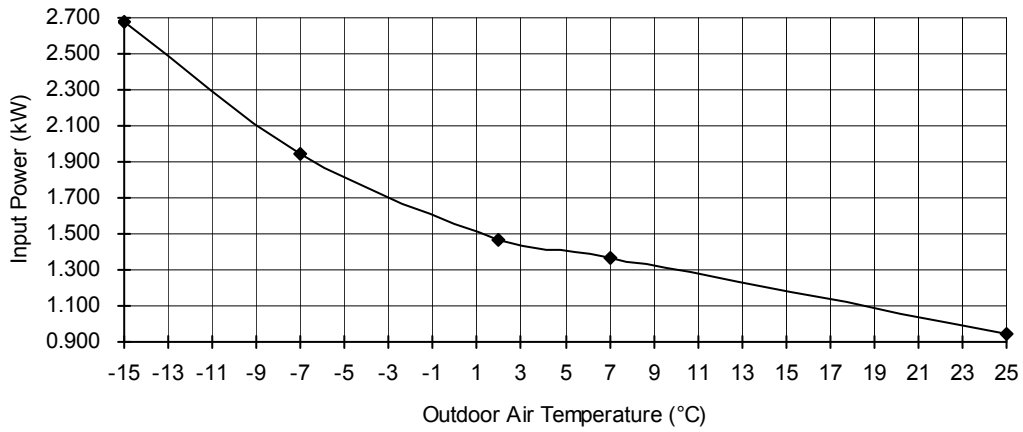
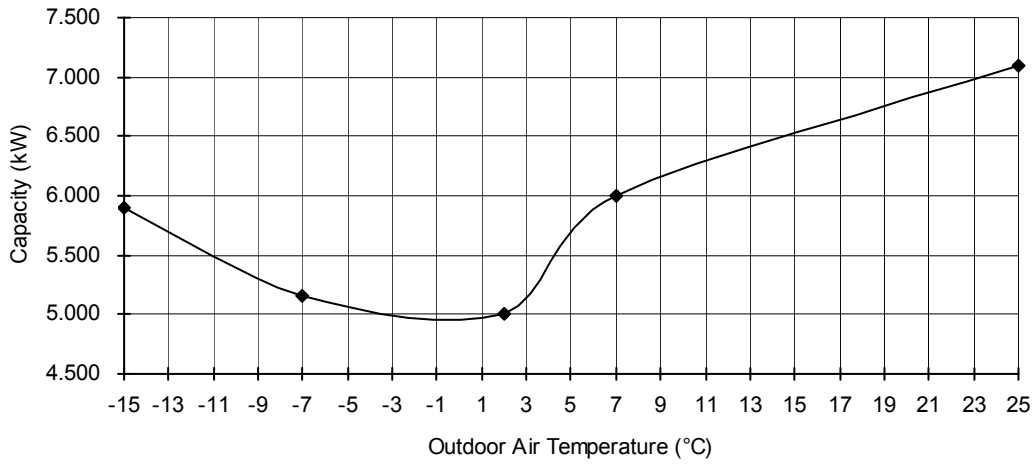

18.1.2 WH-MDF09D3E5

Heating Characteristics at Different Outdoor Air Temperature

Condition

Outdoor air temperature : 7°C (DBT), 6°C (WBT)

Indoor water inlet temperature : 30°C

Indoor water outlet temperature : 35°C

Piping length : 7m

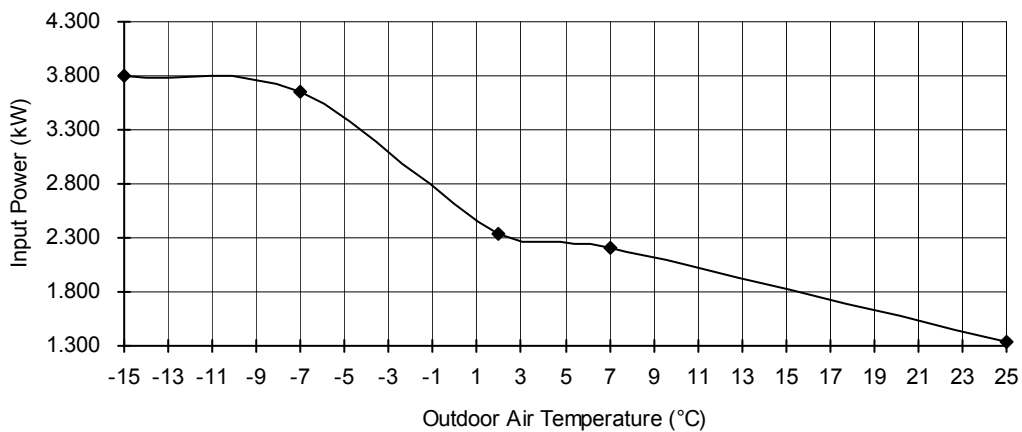
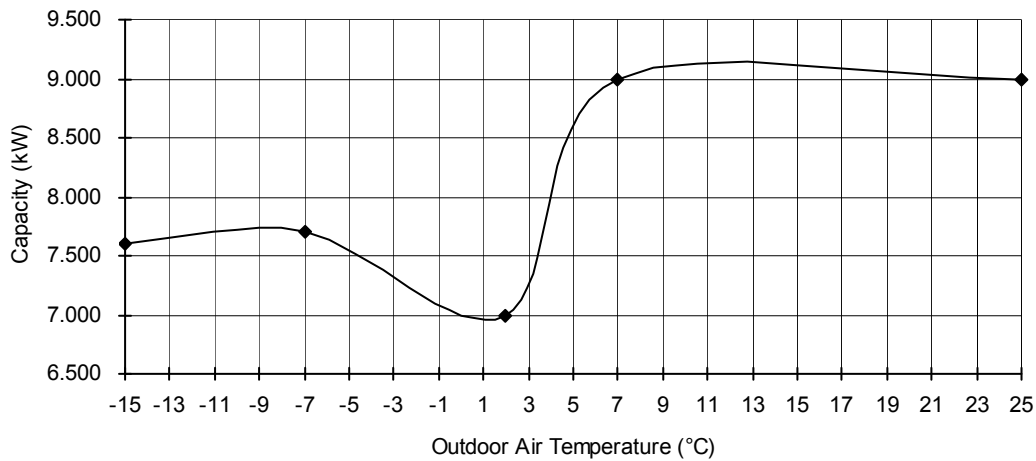

18.2 Heating Capacity Table

18.2.1 WH-MDF06D3E5

Water Out	30		35		40		45		50		55	
Outdoor Air	Capacity	Input Power	Capacity	Input Power	Capacity	Input Power	Capacity	Input Power	Capacity	Input Power	Capacity	Input Power
-15	6150	2520	5900	2680	5650	2840	5400	3000	5200	3170	5000	3340
-7	5175	1695	5150	1940	5125	2185	5100	2430	5450	2825	5800	3220
2	5000	1245	5000	1470	5000	1695	5000	1920	5000	2210	5000	2500
7	6000	1145	6000	1370	6000	1595	6000	1820	6000	2110	6000	2400
25	7300	795	7100	950	6900	1105	6700	1260	6500	1430	6300	1600

18.2.2 WH-MDF09D3E5

Water Out	30		35		40		45		50		55	
Outdoor Air	Capacity	Input Power	Capacity	Input Power	Capacity	Input Power	Capacity	Input Power	Capacity	Input Power	Capacity	Input Power
-15	7900	3645	7600	3800	7300	3955	7000	4110	6450	4085	5900	4060
-7	7800	3410	7700	3660	7600	3910	7500	4160	7550	4620	7600	5080
2	7000	2035	7000	2330	7000	2625	7000	2920	7000	3400	7000	3880
7	9000	1895	9000	2200	9000	2505	9000	2810	8950	3340	8900	3870
25	9000	1020	9000	1340	9000	1660	9000	1980	9000	2230	9000	2480

18.3 Hydraulic Pump Performance

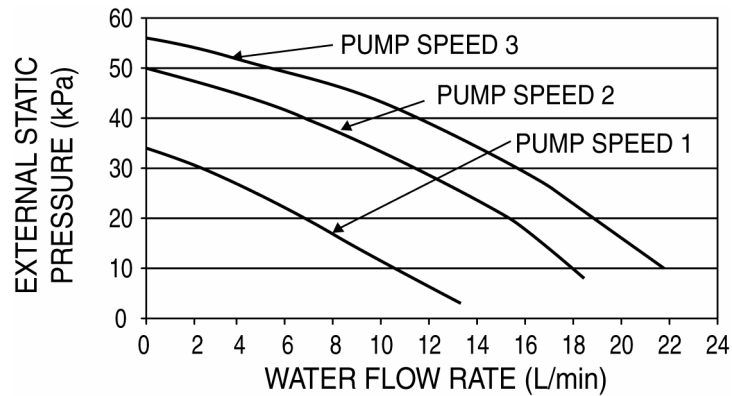

19. Exploded View and Replacement Parts List

19.1 WH-MDF06D3E5 WH-MDF09D3E5 (Refrigerant System)

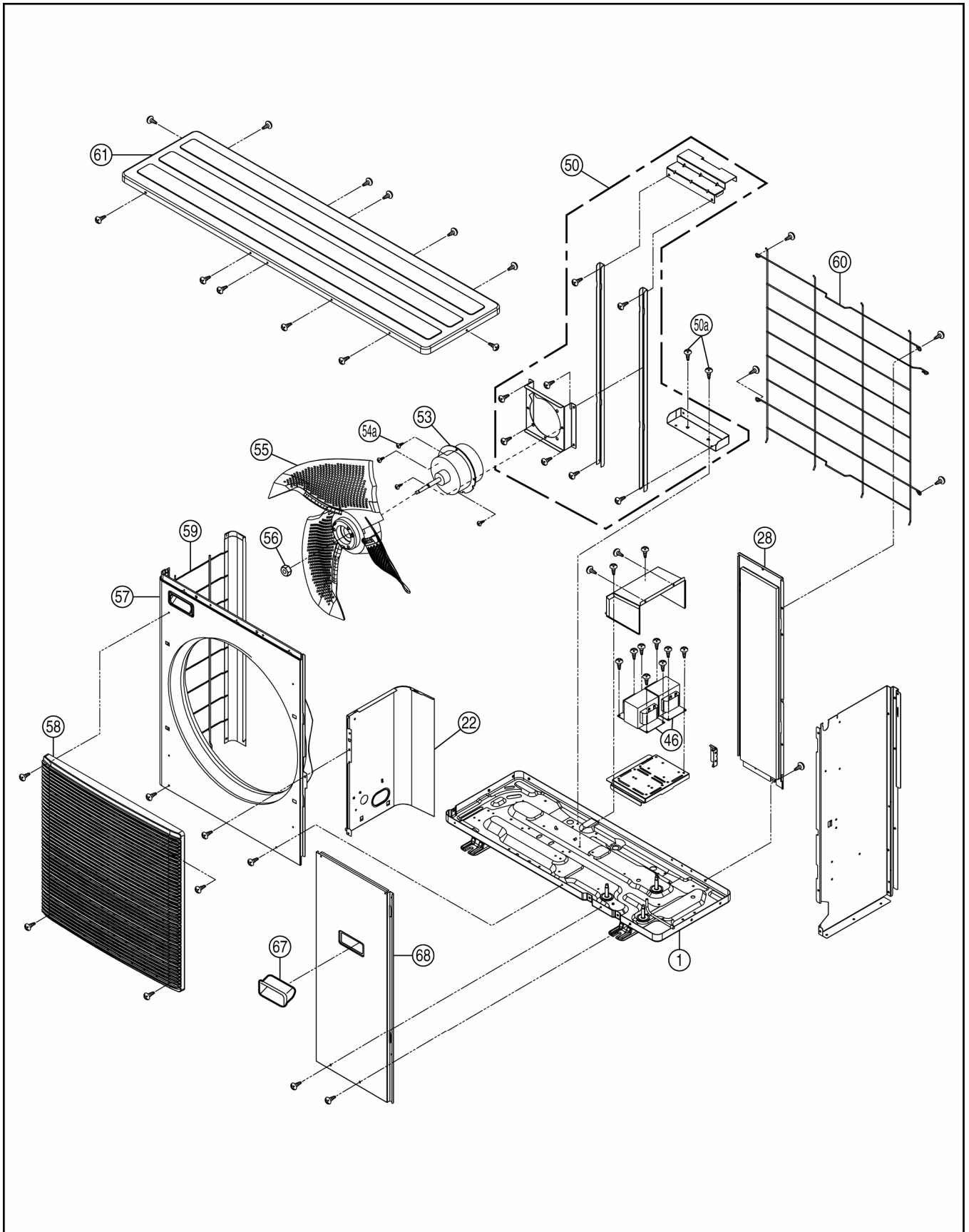

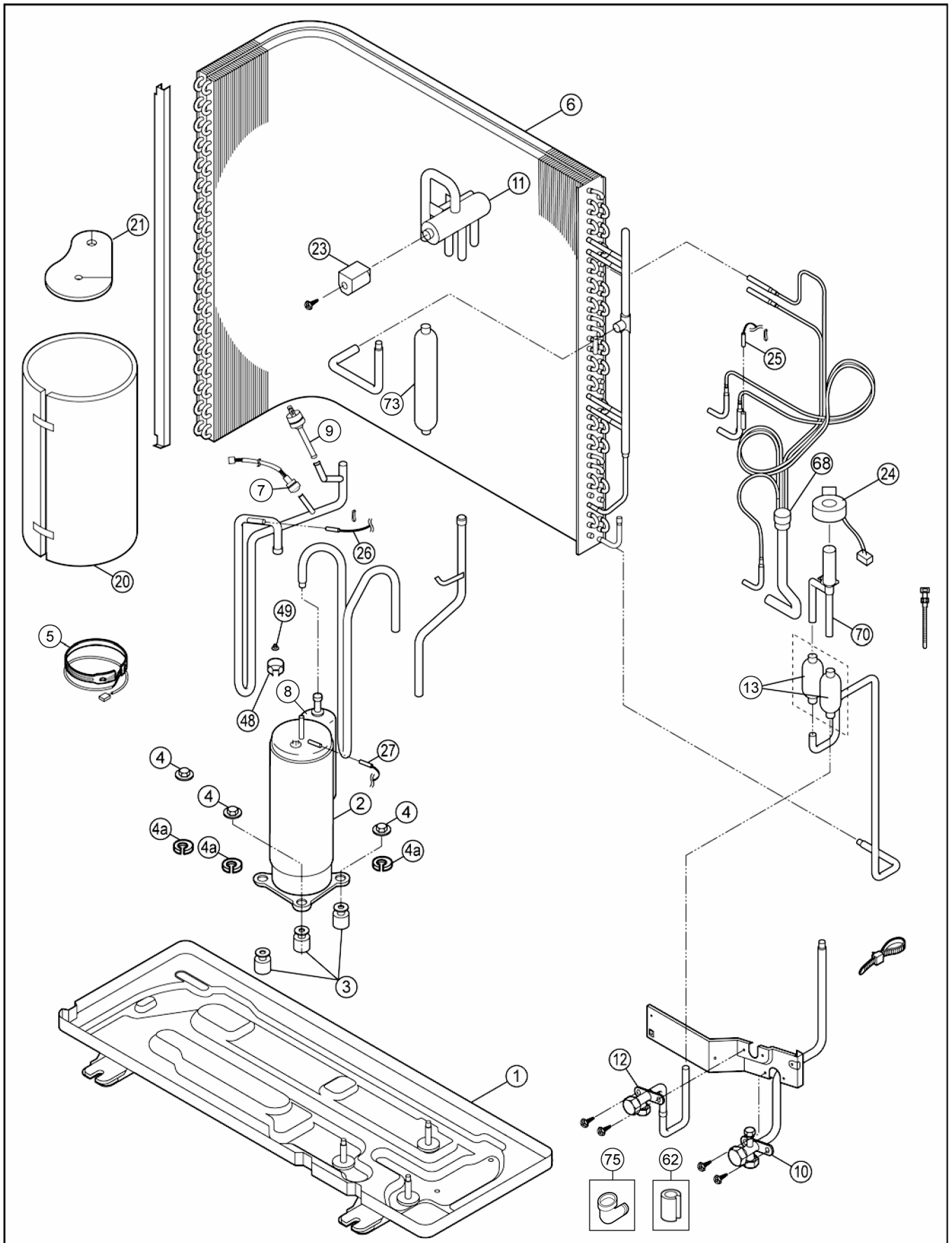

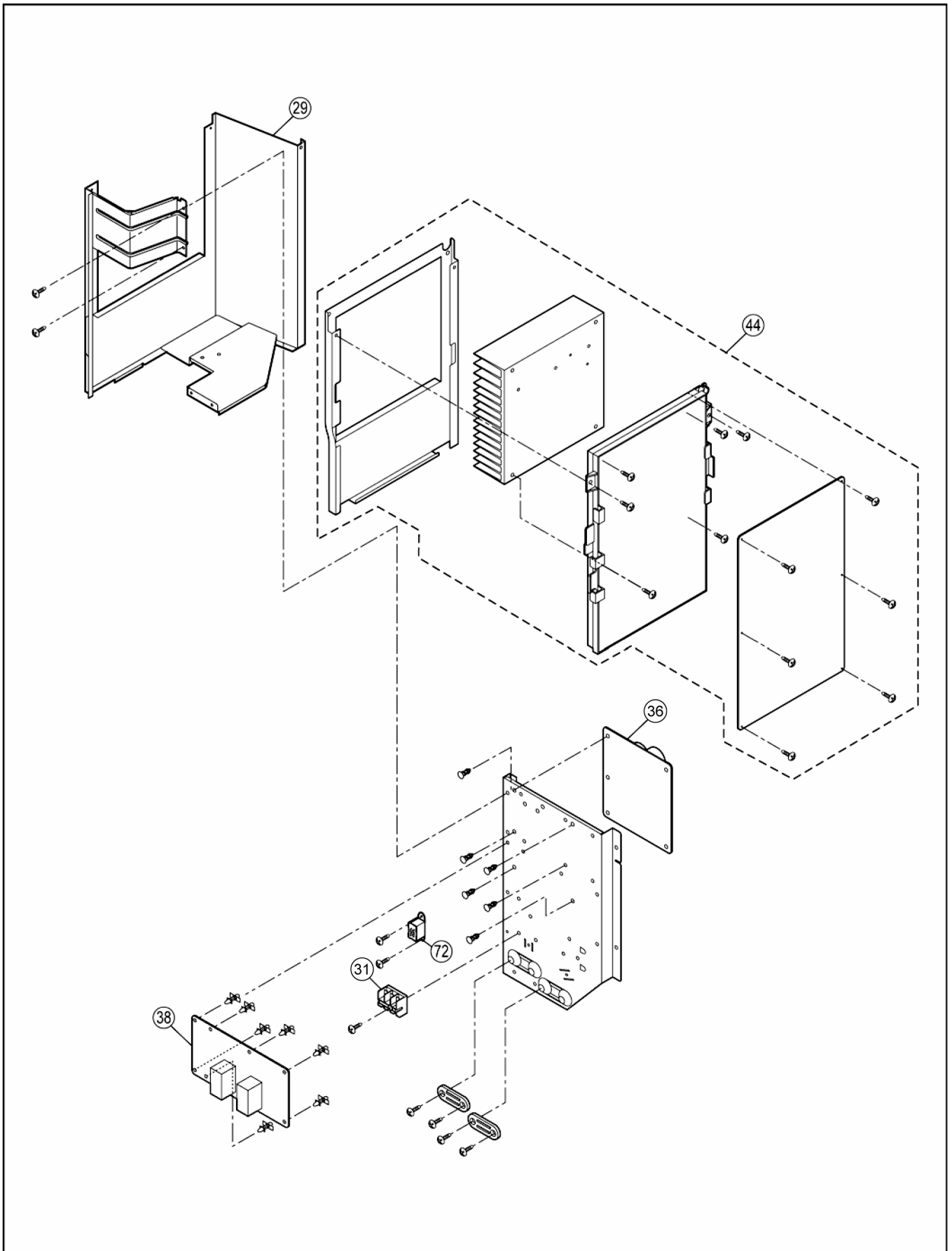

Note:

- The above exploded view is for the purpose of parts disassembly and replacement.
- The non-numbered parts are not kept as standard service parts.

< Model: Refrigerant System >

REF. NO.	DESCRIPTION & NAME	QTY.	WH-MDF06D3E5	WH-MDF09D3E5	REMARK
1	BASE PAN ASS'Y	1	CWD52K1282	←	
2	COMPRESSOR	1	5KD240XCC21	←	O
3	BUSHING - COMPRESSOR MOUNT	3	CWH50055	←	
4	NUT-COMPRESSOR MOUNT	3	CWH561049	←	
4a	GASKET FOR TERMINAL COVER	3	CWB811017	←	
5	CRANKCASE HEATER	1	CWA341043	←	
6	CONDENSER COMPLETE	1	CWB32C2846	←	
7	HIGH PRESSURE SENSOR	1	CWA50C2570	←	O
8	DISCHARGE MUFFLER	1	CWB121013	←	
9	PRESSURE SWITCH	1	CWA101013	←	O
10	3-WAYS VALVE (GAS)	1	CWB011251	←	O
11	4-WAYS VALVE	1	CWB001026J	←	O
12	2-WAYS VALVE (LIQUID)	1	CWB021330	←	
13	STRAINER	2	CWB111024	←	
20	SOUND PROOF MATERIAL	1	CWG302683	CWG302678	
21	SOUND PROOF MATERIAL	1	CWG302246	←	
22	SOUND PROOF BOARD	1	CWH151195	←	
23	V-COIL COMPLETE - 4-WAY VALVE	1	CWA43C2169J	←	O
24	V-COIL COMPLETE - EXP.VALVE	1	CWA43C2342	←	O
25	SENSOR-COMPLETE	1	CWA50C2652	←	O
26	SENSOR-COMP.DISCHARGE	1	CWA50C2528	←	O
27	SENSOR-COMP.TANK	1	CWA50C2665	←	O
28	CABINET REAR PLATE-COMPLETE	1	CWE02C1062	←	
29	CONTROL BOARD CASING	1	CWH10K1150	←	
31	TERMINAL BOARD ASS'Y	1	CWA28K1251	←	O
36	ELECTRONIC CONTROLLER-CAPACITOR	1	CWA746184	←	O
38	ELECTRONIC CONTROLLER-NOISE FILTER	1	CWA745745	←	
44	ELECTRONIC CONTROLLER (MAIN)	1	CWA73C5978R	CWA73C5979R	O
46	REACTOR	2	G0C592J00005	←	O
48	TERMINAL COVER	1	CWH171039A	←	
49	NUT-TERMINAL COVER	1	CWH7080300J	←	
50	FAN MOTOR BRACKET	1	CWD54K1052	←	
50a	SCREW-FAN MOTOR BRACKET	2	CWH551040J	←	
53	FAN MOTOR	1	EHDS80C60AC	←	O
54a	SCREW-FAN MOTOR MOUNT	4	CWH551016J	←	
55	PROPELLER FAN ASSY	1	CWH00K1006	←	
56	NUT	1	CWH561038J	←	
57	CABINET FRONT PLATE	1	CWE061118A	←	
58	DISCHARGE GRILLE	1	CWE201073	←	
59	CABINET SIDE PLATE ASSY	1	CWE04K1019A	←	
60	WIRE NET	1	CWD041102A	←	
61	CABINET TOP PLATE	1	CWE03C1105	←	
62	ACCESSORY CO.(RUBBER CAP)	1	CWH82C1839	←	
66	CABINET FRONT PLATE	1	CWE06C1359	←	
67	HANDLE	2	CWE161008	←	
68	TUBE ASSY (CAP.TUBE)	1	CWT07K1547	←	
70	EXPANSION VALVE	1	CWB051029	←	O
72	ELECTRO MAGNETIC SWITCH	1	CWA001023	←	O
73	RECEIVER	1	CWB141067	←	
75	ACCESSORY CO. (DRAIN ELBOW)	1	CWG87C2030	←	

Note:

- All parts are supplied from PHAAM, Malaysia (Vendor Code: 00029488).
- "O" marked parts are recommended to be kept in stock.

**19.2 WH-MDF06D3E5 WH-MDF09D3E5
(Water System)**

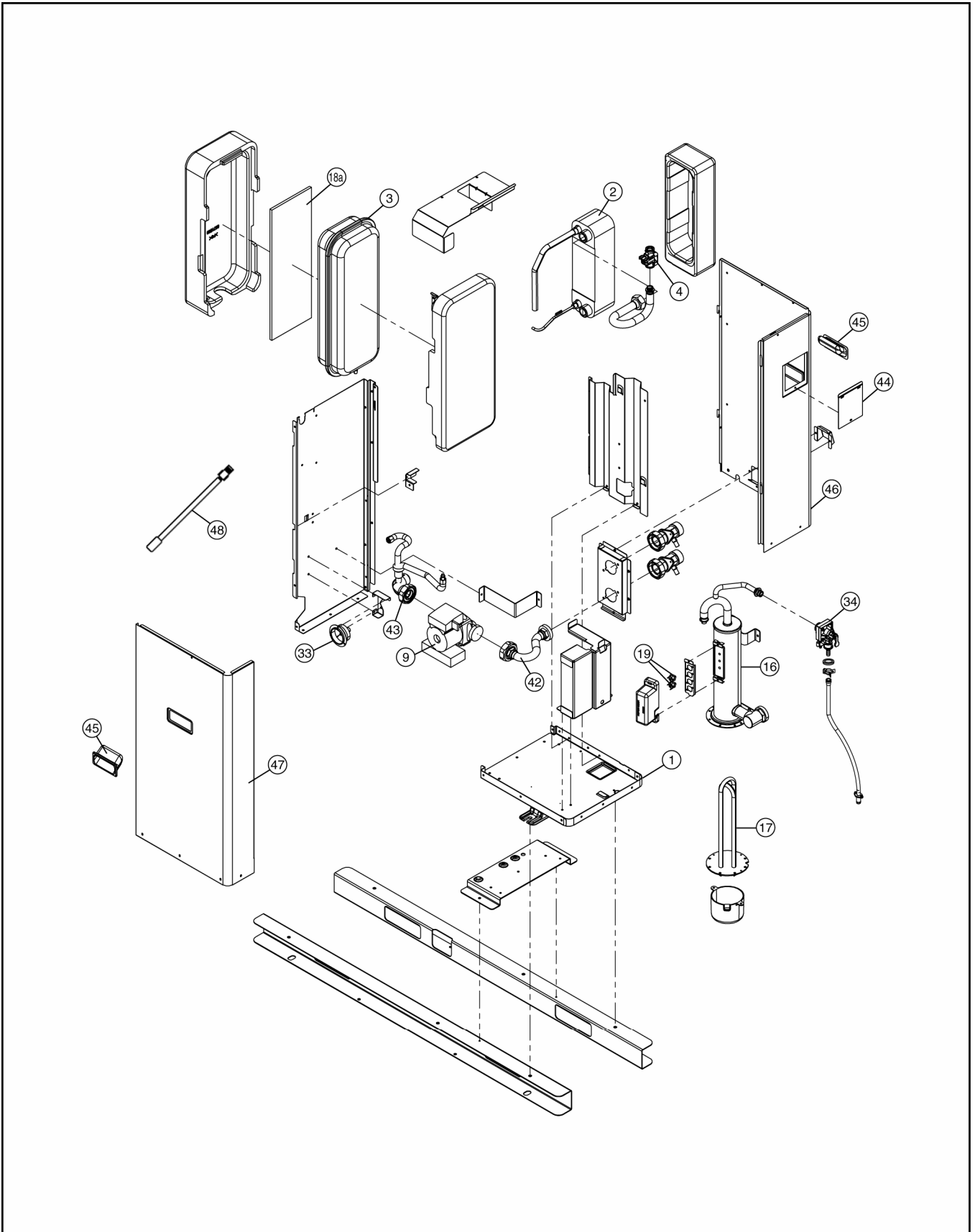

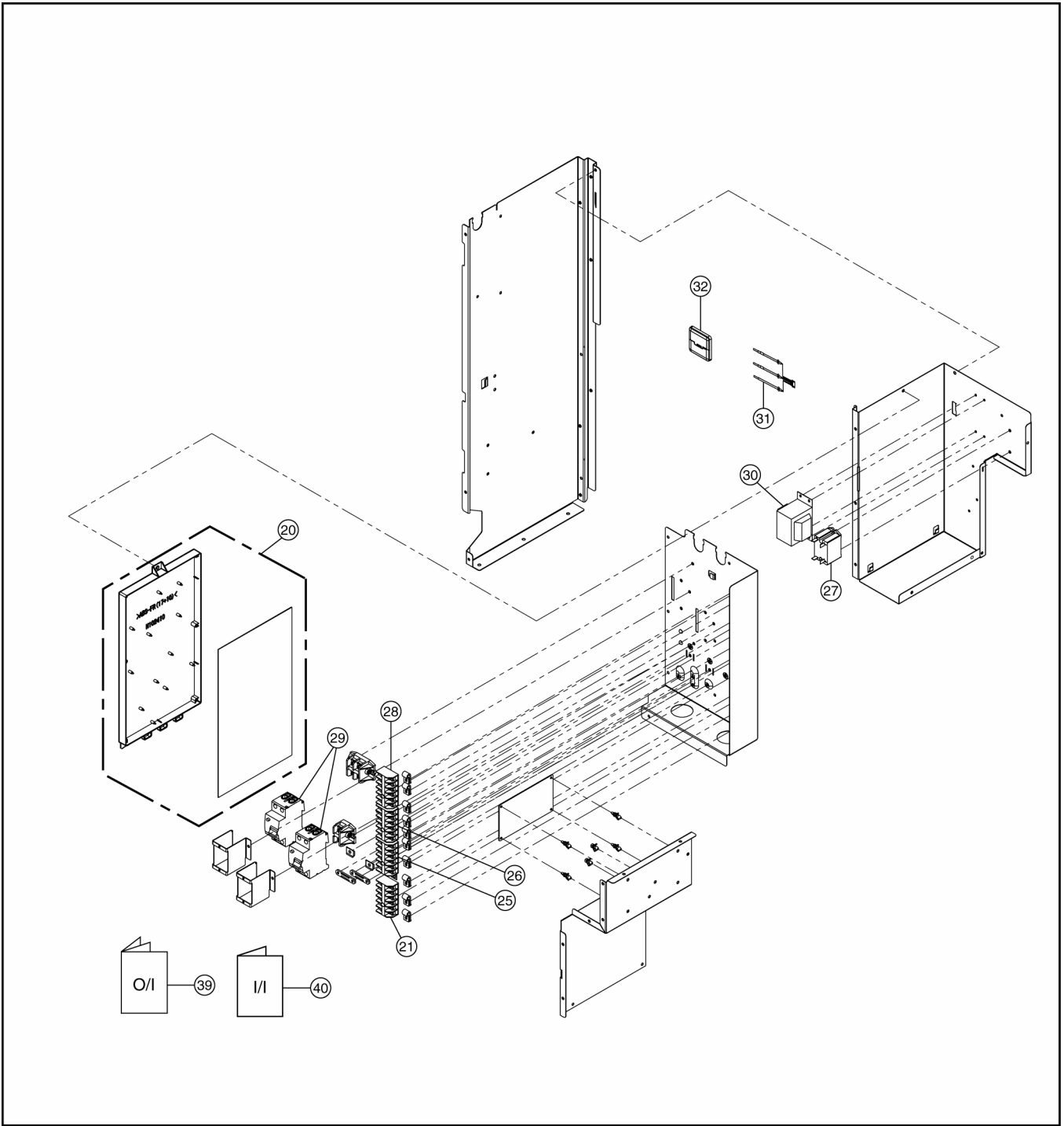

Note:

- The above exploded view is for the purpose of parts disassembly and replacement.
- The non-numbered parts are not kept as standard service parts.

< Model: Water System >

REF. NO.	DESCRIPTION & NAME	QTY.	WH-MDF06D3E5	WH-MDF09D3E5	REMARK
1	BASE PAN ASS'Y	1	CWD52K1279	←	
2	HOT WATER COIL-COMPLETE	1	CWB90C1067	←	O
3	RECEIVER	1	CWB141066	←	
4	FLOW SWITCH	1	CWB621034	←	
9	PUMP	1	CWB532100	←	O
16	BOTTLE COMP.	1	CWH90C0024	←	
17	HEATER ASS'Y	1	CWA34K1026	←	
18a	SOUND PROOF MATERIAL	1	CWG302649	←	
19	THERMOSTAT	2	CWA151065	←	O
20	ELECTRONIC CONTROLLER (MAIN)	1	CWA73C5984R	CWA73C5985R	O
21	TERMINAL BOARD ASS'Y-VALVE	1	CWA28K1229	←	O
25	TERMINAL BOARD ASS'Y-RECEIVER	1	CWA28K1230	←	O
26	TERMINAL BOARD ASS'Y	1	CWA28K1231	←	O
27	MAGNET RELAYS	1	K6C1AYY00004	←	O
28	TERMINAL BOARD ASS'Y-SOLAR	1	CWA28K1232	←	O
29	CIRCUIT BREAKER	2	CWA181005	←	O
30	TRANSFORMER-COMPLETE	1	CWA40C1096	←	O
31	SENSOR-COMPLETE	1	CWA50C2816	←	O
32	REMOTE CONTROL COMPLETE	1	CWA75C3860	←	O
33	PRESSURE GAUGE	1	CWB070001	←	O
34	PRESSURE RELIEF VALVE	1	CWB621092	←	
39	OPERATING INSTRUCTION	1	CWF568156	←	
40	INSTALLATION INSTRUCTION	1	CWF614926	←	
42	TUBE CONNECTOR-COMPLETE	1	CWT027825	←	
43	TUBE CONNECTOR-COMPLETE	1	CWT01C5774	←	
44	CONTROL BOARD COVER	1	CWH131420A	←	
45	HANDLE	2	CWE161008	←	
46	CABINET SIDE PLATE ASS'Y	1	CWE041584A	←	
47	CABINET FRONT PLATE	1	CWE061293A	←	
48	HEATER	1	CWA341071	←	

Note:

- All parts are supplied from PHAAM, Malaysia (Vendor Code: 00029488).
- "O" marked parts are recommended to be kept in stock.