

1 Features and advantages

High part load efficiency

EWAD~BZ is the result of careful design, aimed to optimizing the energy efficiency of the chillers, with the objective of bringing down operating costs and improving installation profitability, effectiveness and economical management.

Per European Seasonal Energy Efficiency Ratio (ESEER), chillers operate at design conditions only three percent of the time. As a result better part load efficiencies are required at part load conditions in a chiller water applications. EWAD~BZ maximize chiller efficiency by optimizing single screw compressor operation dramatically reducing the electric power consumption when the motor speed slows.

Seasonal quietness

Very low noise levels in part load conditions are achieved by varying the fan speed, but especially thanks to the variation of compressor frequency, which ensure the minimum noise level at all the time.

Quick comfort conditions

The ability to vary the output power in direct relation to the cooling requirements of the system, allow the possibility to achieve building comfort conditions much faster at start-up.

Low starting current

No current spikes at start-up. The starting current is always lower than current absorbed in the maximum operating conditions (FLA).

Power factor always > 0.95

EWAD~BZ can operate always > 0.95 power factor, which can allows building owners avoid power factor penalties and decreases electrical losses in cable and transformers.

Redundancy

EWAD~BZ has two independent refrigerant circuits in every size, in order to assure maximum safety for any maintenance, whether planned or not.

Infinitely capacity control

Cooling capacity control is infinitely variable by means of an Inverter driven screw compressor controlled by a microprocessor system. Each unit has infinitely variable capacity control from 100% down to 13,5%. This modulation allows the compressor capacity to exactly match the building cooling load without any leaving evaporator water temperature fluctuation. This chilled water temperature fluctuation is avoided only with a stepless control.

With a compressor load step control in fact, the compressor capacity, at partial loads, will be too high or too low compared to the building cooling load. The result is an increase in chiller energy costs, particularly at the part-load conditions at which the chiller operates most of the time.

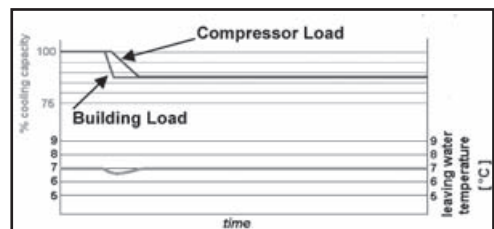
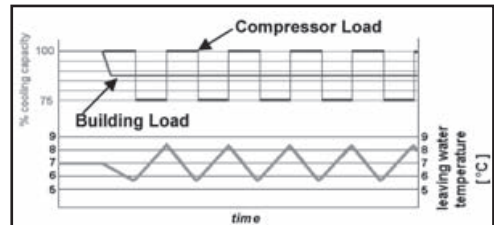

Units with stepless regulation offer benefits that the units with step regulation are unable to match. The ability to follow the system energy demand at any time and the possibility to provide steady outlet water temperature without deviations from the set-point, are the two points that allow you to understand how the optimum operating conditions of a system can be met only through the use of a unit with stepless regulation.

1 Features and advantages

Code requirements – Safety and observant of laws/directives

All EWAD~BZ- units are designed and manufactured in accordance with applicable selections of the following:

Rating of chillers	EN 12055
Construction of pressure vessel	97/23/EC (PED)
Machinery Directive	98/37/EC as modified
Low Voltage	2006/95/EC
Electromagnetic Compatibility	2004/108/EC
Electrical & Safety codes	EN 60204-1 / EN 60335-2-40
Manufacturing Quality Stds	UNI – EN ISO 9001:2000

Certifications

All units manufactured are CE marked, complying with European directives in force, concerning manufacturing and safety. On request units can be produced complying with laws in force in non European countries (ASME, GOST, etc.), and with other applications, such as naval (RINA, etc.).

Versions

EWAD~BZ is available in the following versions:

S: Standard Efficiency

7 sizes to cover a range from 329 up to 515 kW with an ESEER up to 4.70

X: High Efficiency

7 sizes to cover a range from 329 up to 515 kW with an ESEER up to 5.01

The EER (Energy Efficiency Ratio) is the ratio of the Cooling Capacity to the Power Input of the unit. The Power Input includes: the power input for operation of the compressor, the power input of all control and safety devices, the power input for fans.

The ESEER (European Seasonal Energy Efficiency Ratio) is a weighed formula enabling to take into account the variation of EER with the load rate and the variation of air inlet condenser temperature.

$$ESEER = A \times EER_{100\%} + B \times EER_{75\%} + C \times EER_{50\%} + D \times EER_{25\%}$$

	A	B	C	D
Coefficient	0.03 (3%)	0.33 (33%)	0.41 (41%)	0.23 (23%)
Air inlet condenser temperature	35°C	30°C	25°C	20°C

Noise Configuration

EWAD~BZ is available in two or three different noise level configurations:

S: Standard Noise

Condenser fan rotating at 700 rpm, rubber antivibration on compressor

L: Low Noise

Condenser fan rotating at 700 rpm, rubber antivibration on compressor, sound proof cabinet for each compressor

R: Reduced Noise

Condenser fan rotating at 700 rpm, rubber antivibration on compressor, one sound proof cabinet for compressor and evaporator, suction muffler

2 General characteristics

Cabinet and structure

The cabinet is made of galvanized steel sheet and painted to provide a high resistance to corrosion. Colour Ivory White (Munsell code 5Y7.5/1) (\pm RAL7044). The base frame has eye-hook for lifting the unit with ropes for an easy installation. The weight is uniformly distributed along the profiles of the base and this facilitates the arrangement of the unit.

Screw compressors with integrated oil separator

The compressors are semi-hermetic, single-screw type with gate-rotor (made of carbon impregnated engineered composite material). Each compressor has one inverter managed by the unit microprocessor for infinitely modulating the capacity. An integrated high efficiency oil separator maximises the oil separation.

Start is inverter type.

Ecological HFC 134a refrigerant

The compressors have been designed to operate with R-134a, ecological refrigerant with zero ODP (Ozone Depletion Potential) and very low GWP (Global Warming Potential) that means low TEWI (Total Equivalent Warming Impact).

Evaporator

The units are equipped with a Direct Expansion shell&tube evaporator with copper tubes rolled into steel tubesheets. The evaporators are single-pass on both the refrigerant and water sides for pure counter-flow heat exchange and low refrigerant pressure drops. Both attributes contribute to the heat exchanger effectiveness and total unit's outstanding efficiency.

The external shell is covered with a 10mm closed cell insulation material. Each evaporator has 2 circuits, one for each compressor and is manufactured in accordance to PED approval. The evaporator water outlet connections are provided with Victaulic Kit (as standard).

Condenser coils

The condenser is manufactured with internally enhanced seamless copper tubes arranged in a staggered row pattern and mechanically expanded into lanced and rippled aluminium condenser fins with full fin collars. An integral sub-cooler circuit provides sub-cooling to effectively eliminate liquid flashing and increase in cooling capacity without increasing the power input.

Condenser coil fans (version EWAD-BZSS / SL and EWAD-BZXS / XL)

The condenser fans are propeller type with high efficiency design blades to maximize performances. The material of the blades is glass reinforced resin and each fan is protected by a guard. Fan motors are protected by circuit breakers installed inside the electrical panel as a standard. The motors are IP54 and are suitable for use with PWM-operated inverters.

Condenser coil fans (version EWAD-BZXR)

The condenser fans are "brushless" propeller type and are made with synchronous motors excited by permanent magnets and with phase currents controlled by a PWM inverter integrated in the fan motor housing, that allows operation at different speeds. With this technology the fans reach high efficiencies with an extremely low noise level across a very wide speed range.

2 General characteristics

Electronic expansion valve

The unit is equipped with the most advanced electronic expansion valves to achieve precise control of refrigerant mass flow. As today's system requires improved energy efficiency, tighter temperature control, wider range of operating conditions and incorporate features like remote monitoring and diagnostics, the application of electronic expansion valves becomes mandatory. Electronic expansion valve proposes features that make it unique: short opening and closing time, high resolution, positive shut-off function to eliminate use of additional solenoid valve, continuous modulation of mass flow without stress in the refrigerant circuit and corrosion resistance stainless steel body.

Electronic Expansion Valves are typically working with lower ΔP between high and low pressure side, than a thermostatic expansion valve. The electronic expansion valve allows the system to work with low condenser pressure (winter time) without any refrigerant flow problems and with a perfect chilled water leaving temperature control.

Refrigerant Circuit

Each unit has 2 independent refrigerant circuits and each one includes:

- Compressor with integrated oil separator
- Air Cooled Condenser
- Electronic expansion valve
- Evaporator
- Discharge line shut off valve
- Liquid line shut off valve
- Suction line shut off valve
- Sight glass with moisture indicator
- Filter drier
- Charging valves
- High pressure switch
- High and low pressure transducers

Electrical control panel

Power and control are located in two sections of the main panel that is manufactured to ensure protection against all weather conditions. The electrical panel is IP54 and (when opening the doors) internally protected with Plexiglas panel against possible accidental contact with electrical components. The main panel is fitted with a main switch interlocked door.

Power Section

The power section includes circuit breaker, compressors inverters, fans contactors, fans thermal overload relays, fans inverter and control circuit transformer.

MicroTech II controller

MicroTech II C Plus controller is installed as standard; it can be used to modify unit set-points and check control parameters. A built-in display shows machine's operating status, programmable values, set-points, like temperatures and pressures of water, refrigerant and air. Device controls maximise the chiller energy efficiency and the reliability. A sophisticated software with predictive logic, select the most energy efficient combination of compressors, EEXV and condenser fans to keep stable operating conditions and maximise energy efficiency. The compressors are automatically rotated to ensure equal operating hours. MicroTech II C Plus protects critical components in response to external signals from its system sensors measuring: motor temperatures, refrigerant gas and oil pressures, correct phase sequence and evaporator.

2 General characteristics

Control section - main features

- Management of the compressor capacity, Inverter, slide and fans modulation.
- Chillers enabled to work in partial failure condition.
- Full routine operation at condition of:
 - high ambient temperature value,
 - high thermal load,
 - high evaporator entering water temperature (start-up).
- Display of evaporator entering/leaving water temperature.
- Display of condensing-evaporating temperature and pressure, suction and discharge superheat for each circuit.
- Leaving water cooled temperature regulation. Temperature tolerance = 0,1°C.
- Compressors and evaporator pumps hours counter.
- Display of Status Safety Devices.
- Start up numbers and compressors working hours equalization.
- Optimized management of compressors load.
- Fans management according to condensing pressure.
- Automatic re-start in case of power supply interruption (adjustable).
- Soft Load.
- Start at high evaporator water temperature.
- Return Reset.
- AOT Reset (optional).
- Set point Reset (optional).

Safety device / logic for each refrigerant circuit

- High pressure (pressure switch).
- Low pressure (transducer).
- Condensation fan Magneto-thermal.
- High Discharge Temperature on the compressor.
- Phase Monitor.
- Low pressure ratio.
- High oil pressure drop.
- Low oil pressure.

System security

- Phase monitor.
- Freeze protection.

Regulation type

Proportional + integral + derivative regulation on the leaving water evaporator output probe.

Condensing pressure

The condensation can be carried out according to temperature or pressure or pressure ratio. The fans can be managed according to a 0/10 V modulating signal.

Intelligent Compressor Start Mode

Control software includes an intelligent compressor start mode that unloads the first compressor to 75% during the start of the second one, in order to reduce inrush current.

2 General characteristics

MicroTech II C Plus terminal

MicroTech II C Plus built-in terminal has the following features.

- 4-lines by 20-character liquid crystal display back lighting.
- Key-pad consisting of 6 keys.
- Memory to protect the data.
- General faults alarm relays.
- Password access to modify the setting.
- Service report displaying all running hours and general conditions.
- Alarm history memory to allow an easy fault analysis.

Supervising systems (on request)

MicroTech II C Plus remote control

MicroTech II C Plus is able to communicate to BMS (Building Management System) based on the most common protocols as:

- CARELNative
- ModbusRTU
- LonWorks, now also based on the international 8040 Standard Chiller Profile and LonMark Technology
- BacNet BTP certified over IP and MS/TP (class 4)
- Ethernet TCP/IP and SNM.

Standard accessories (supplied on basic unit)

Double set-point – Dual leaving water temperature set-points.

Fans circuit breaker with thermal overload relays – Safety devices against motor overloading and short circuit in addition to the normal protection envisaged by the electrical windings.

Phase monitor – The phase monitor controls that phases sequence is correct and controls phase loss.

Inverter compressor starter – For low inrush current and reduced starting torque.

Evaporator Victaulic kit on water connection – Hydraulic joint with gasket for an easy and quick water connection.

Fan Silent Mode - The microprocessor clock switches the fan at low speed according to the client setting (i.e. Night & Day), providing that the ambient temperature/condensing pressure is allowing the speed change.

Fan speed regulation – To control the fan speed revolution for smooth operating control of the unit. This option improves the sound level of the unit during low ambient temperature operation.

10mm evaporator insulation

Evaporator electric heater – Electric heater controlled by a thermostat to protect the evaporator from freezing down to -28°C ambient temperature, providing the power supply is on.

Electronic expansion valve

Discharge line shut off valves – Installed on the discharge port of the compressor to facilitate maintenance operation.

Suction line shut off valve – Installed on the suction port of the compressor to facilitate maintenance operation.

Low pressure side manometers

Compressor hour run meter

General fault – Alarm relay.

Main switch interlock door

2 General characteristics

Options (on request)

Total heat recovery – Produced with shell and tube heat exchangers to produce hot water up to +55°C. The heat exchangers are mounted on both the refrigerant circuits (2 refrigerant circuits) parallel to the condenser coils to remove all the condensation heat.

Total heat recovery 1 circuit – Produced with shell and tube heat exchangers to produce hot water up to +55°C. The heat exchanger is mounted on one refrigerant circuit parallel to the condenser coils to remove all the condensation heat.

Partial heat recovery – Produced with plate to plate heat exchangers installed between the compressor discharge and the condenser coil, allowing to produce hot water.

Brine version – Allows the unit to operate down to -8°C leaving liquid temperature (antifreeze required).

Under/Over Voltage – This device controls the voltage value of power supply and stops the chiller if the value exceeds the allowed operating limits.

Energy Meter – This device allows to measure the energy absorbed by the chiller during its life. It is installed inside the control box mounted on a DIN rail and shows on a digital display: Line-to-Line Voltage, Phase and Average Current, Active and Reactive Power, Active Energy, Frequency.

Current limit – To limit maximum absorbed current of the unit whenever is required

20mm evaporator insulation

Condenser coil guards

Cu-Cu condensing coils – To give better protection against corrosion by aggressive environments.

Cu-Cu-Sn condensing coils – To give better protection against corrosion in aggressive environments and by salty air.

Alucoat condensing coils – Fins are protected by a special acrylic paint with a high resistance to corrosion.

Evaporator Flow switch – Supplied separately to be wired and installed on the evaporator water piping (by the customer).

High pressure side manometers

Kit container

Rubber type antivibration mounts – Supplied separately, these are positioned under the base of the unit during installation. Ideal to reduce the vibrations when the unit is floor mounted.

Spring type antivibration mounts – Supplied separately, these are positioned under the base of the unit during installation. Ideal for dampening vibrations for installation on roofs and metallic structures.

Water circulation pump (low or high lifting) – Hydronic kit consists of: single direct driven centrifugal pump, water filling system with pressure gauge, safety valve, drain valve. The motor pump is protected by a circuit breaker installed in control panel. The kit is assembled and wired to the control panel. The pipe and pump are protected from freezing with an additional electrical heater.

Two water circulation pumps (low or high lifting) – Hydronic kit consists of: twin direct driven centrifugal pumps, water filling system with pressure gauge, safety valve, drain valve. The motor pump is protected by a circuit breaker installed in control panel. The kit is assembled and wired to the control panel. The pipe and pumps are protected from freezing with an additional electrical heater.

Inertial tank with cabinet (500 l or 1000 l) – Piping to unit are not included and electric heater power supply has to be provided from external source.

Witness test – Every unit is always tested at the test bench prior to the shipment. On request, a second test can be carried out, at customer's presence, in accordance with the procedures indicated on the test form. (Not available for units with glycol mixtures).

Set-point reset, demand limit and alarm from external device – The leaving water temperature set-point can be overwritten with the following options: 4-20mA from external source (by user); outside ambient temperature; evaporator water temperature Δt . Moreover the device allows the user to limit the load of the unit by 4-20mA signal or by network system and the microprocessor is able to receive an alarm signal from an external device (pump etc... - user can decide if this alarm signal will stop or not the unit).

Double pressure relief valve with diverter

GNC_1-2-3-4-5_Rev.00_5

3 Nomenclature

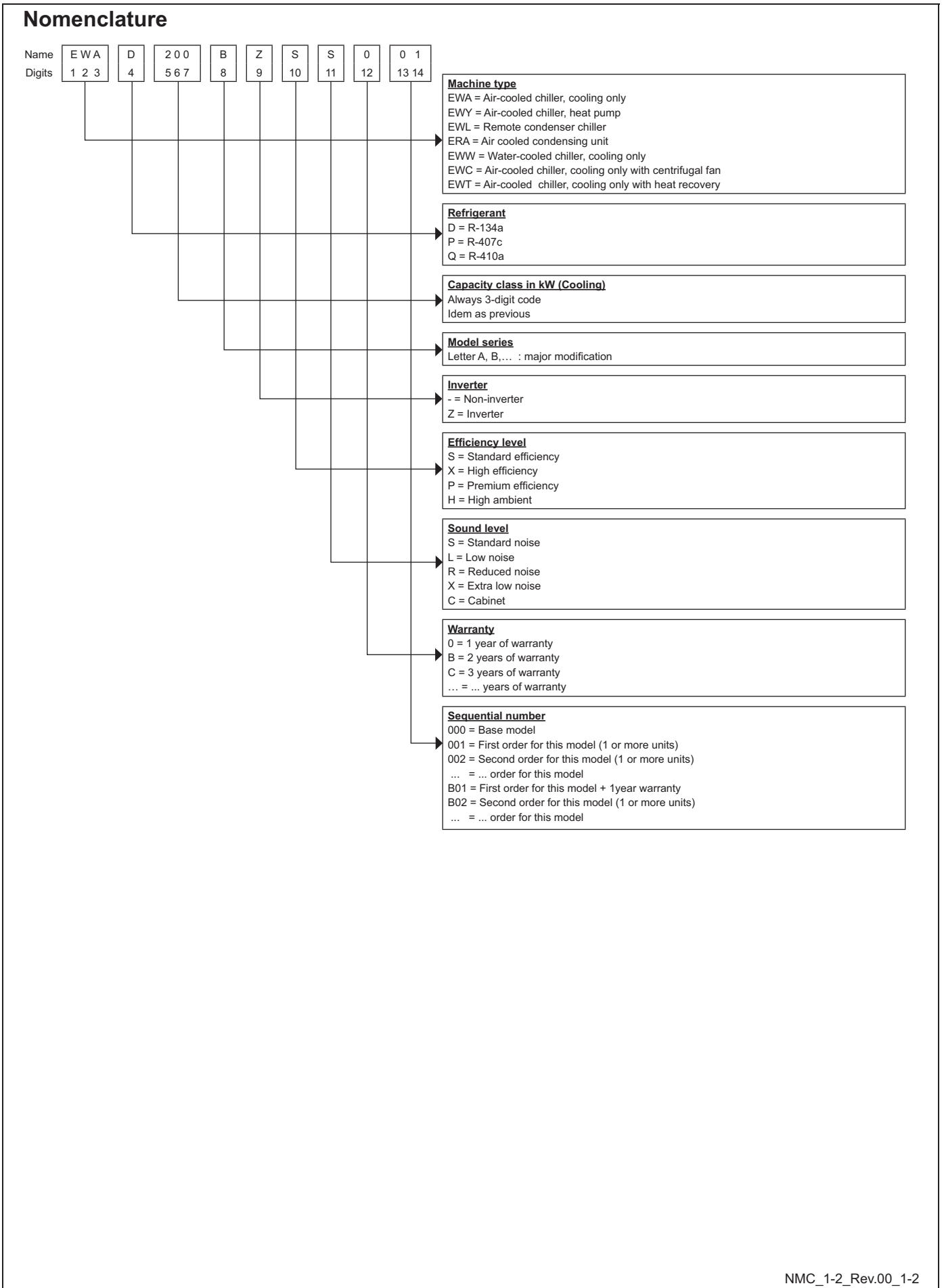

4 Technical specifications

4-1 Technical Specifications			EWAD-BZSS EWAD-BZSL	330	360	400	420	460	490	520
Capacity (1)	Cooling	kW		329	358	395	423	459	488	515
Capacity control	Type	---	Stepless							
	Minimum capacity	%	13,5							
Unit power input (1)	Cooling	kW	120,0	136	147	159	168	181	193	
EER (1)		---	2,74	2,63	2,69	2,66	2,73	2,70	2,67	
ESEER		---	4,59	4,60	4,55	4,59	4,57	4,70	4,60	
IPLV		---	5,53	5,62	5,49	5,63	5,49	5,60	5,54	
Casing	Colour	---	Ivory White							
	Material	---	Galvanized and painted steel sheet							
Dimensions	Unit	Height	mm	2355						
		Width	mm	2224						
		Length	mm	4352	5252		6152			
Weight	Unit	kg	4190	4590		5070				
EWAD-BZSS	Operating Weight	kg	4440	4840		5320				
Weight	Unit	kg	4340	4740		5220				
EWAD-BZSL	Operating Weight	kg	4590	4990		5470				
Water heat exchanger	Type	---	Single Pass Shell&Tube							
	Water volume	l	271	264	264	256	256	248	248	
	Nominal water flow rate	Cooling l/s	15,72	17,10	18,87	20,21	21,93	23,32	24,61	
	Nominal Water pressure drop	Cooling kPa	60	61	72	67	78	69	76	
	Insulation material		Closed cell							
Air heat exchanger	Type	---	High efficiency fin and tube type with integral subcooler							
Fan	Type	---	Direct propeller type							
	Drive	---	VFD driven							
	Diameter	mm	800							
	Nominal air flow	l/s	32667	40833		49000				
	Model	Quantity	No.	8	10		12			
		Speed	rpm	700						
Motor input		W	1133							
Compressor	Type	---	Semi-hermetic single screw compressor Inverter driven							
	Oil charge	l	26							
	Quantity	No.	2							
Sound level	Sound Power	Cooling dB(A)	102,8	103,2		103,6				
EWAD-BZSS	Sound Pressure (2)	Cooling dB(A)	83,0	83,0		83,5				
Sound level	Sound Power	Cooling dB(A)	96,9	97,3		98,2				
EWAD-BZSL	Sound Pressure (2)	Cooling dB(A)	77,0				77,5			
Refrigerant circuit	Refrigerant type	---	R-134a							
	Refrigerant charge	kg.	80	100		120				
	N. of circuits	No.	2							
Piping connections	Evaporator water inlet/outlet	mm	168,3							
Safety devices	High discharge pressure (pressure switch)									
	High discharge pressure (pressure transducer)									
	Low suction pressure (pressure transducer)									
	Compressor overload (Kriwan)									
	High discharge temperature									
	Low oil pressure									
	Low pressure ratio									
	High oil filter pressure drop									
	Phase monitor									
Notes (1)	Cooling capacity, unit power input in cooling and EER are based on the following conditions: evaporator 12/7°C; ambient 35°C, unit at full load operation.									
Notes (2)	The values are according to ISO 3744 and are referred to: evaporator 12/7°C, ambient 35°C, full load operation.									

4 Technical specifications

4-2 Electrical Specifications		EWAD-BZSS EWAD-BZSL	330	360	400	420	460	490	520	
Power Supply	Phase	---	3							
	Frequency	Hz	50							
	Voltage	V	400							
	Voltage Tolerance	Minimum	%	-10%						
		Maximum	%	+10%						
Unit	Maximum starting current	A	232	250	251	278	297	311	316	
	Nominal running current cooling	A	194	220	239	258	273	292	312	
	Maximum running current	A	322		328	358	394			
	Maximum current for wires sizing	A	355		361	394	433			
	Min. displacement power factor at nominal conditions	---	0,98							
Fans	Nominal running current in cooling	A	22,4		28		33,6			
Compressor	Phase	No.	3							
	Voltage	V	400							
	Voltage Tolerance	Minimum	%	-10%						
		Maximum	%	+10%						
	Maximum running current	A	150+150				180+180			
Starting method	---	VFD								
Notes	Allowed voltage tolerance $\pm 10\%$. Voltage unbalance between phases must be within $\pm 3\%$.									
	Maximum starting current: starting current of biggest compressor + current of the compressor at 75% maximum load + fans current for the circuit at 75%.									
	Nominal current in cooling mode is referred to installation with 25kA short circuit current and is based on the following conditions: evaporator 12°C/7°C; ambient 35°C.compressor + fans current.									
	Maximum running current is based on max compressor absorbed current in its envelope and max fans absorbed current									
Maximum current for wires sizing: (compressors full load ampere + fans current) x 1,1.										

4 Technical specifications

4-3 Technical Specifications			EWAD~BZXS EWAD~BZXL/EWAD~BZXR	330	360	400	420	460	490	520
Capacity (1)	Cooling		kW	329	358	395	423	459	488	515
Capacity control	Type		---	Stepless						
	Minimum capacity		%	13,5						
Unit power input (1)	Cooling		kW	118,0	135	145	157	165	178	190
EER (1)			---	2,79	2,65	2,72	2,69	2,78	2,74	2,71
ESEER			---	4,79	4,82	4,78	4,84	4,81	5,01	4,84
IPLV			---	5,76	5,86	5,73	5,87	5,73	5,84	5,78
Casing	Colour		---	Ivory White						
	Material		---	Galvanized and painted steel sheet						
Dimensions	Unit	Height	mm	2355						
		Width	mm	2224						
	Length	mm	4352	5252			6152			
Weight EWAD~BZXS	Unit		kg	4190	4590			5070		
	Operating Weight		kg	4440	4840			5320		
Weight EWAD~BZXL	Unit		kg	4340	4740			5220		
	Operating Weight		kg	4590	4990			5470		
Weight EWAD~BZXR	Unit		kg	4390	4790			5270		
	Operating Weight		kg	4640	5040			5520		
Water heat exchanger	Type		---	Single Pass Shell&Tube						
	Water volume		l	271	264	264	256	256	248	248
	Nominal water flow rate	Cooling	l/s	15,72	17,10	18,87	20,21	21,93	23,32	24,61
	Nominal Water pressure drop	Cooling	kPa	60	61	72	67	78	69	76
	Insulation material			Closed cell						
Air heat exchanger	Type		---	High efficiency fin and tube type with integral subcooler						
Fan	Type		---	Direct propeller type						
	Drive		---	VFD driven						
	Diameter		mm	800						
	Nominal air flow		l/s	32667	40833			49000		
	Model	Quantity	No.	8	10			12		
		Speed	rpm	700						
	Motor input	W	900				1133			
Compressor	Type		---	Semi-hermetic single screw compressor Inverter driven						
	Oil charge		l	26						
	Quantity	No.	2							
Sound level EWAD~BZXS	Sound Power	Cooling	dB(A)	102,8	103,2			103,6		
	Sound Pressure (2)	Cooling	dB(A)	83				83,5		
Sound level EWAD~BZXL	Sound Power	Cooling	dB(A)	96,9	97,3			98,2		
	Sound Pressure (2)	Cooling	dB(A)	77,0				77,5		
Sound level EWAD~BZXR	Sound Power	Cooling	dB(A)	92,9	93,3			94,2		
	Sound Pressure (2)	Cooling	dB(A)	73,0				73,5		
Refrigerant circuit	Refrigerant type		---	R-134a						
	Refrigerant charge		kg.	80	100			120		
	N. of circuits		No.	2						
Piping connections	Evaporator water inlet/outlet		mm	168,3						
Safety devices	High discharge pressure (pressure switch)									
	High discharge pressure (pressure transducer)									
	Low suction pressure (pressure transducer)									
	Compressor overload (Kriwan)									
	High discharge temperature									
	Low oil pressure									
	Low pressure ratio									
	High oil filter pressure drop,									
Phase monitor										
Notes (1)	Cooling capacity, unit power input in cooling and EER are based on the following conditions: evaporator 12/7°C; ambient 35°C, unit at full load operation.									
Notes (2)	The values are according to ISO 3744 and are referred to: evaporator 12/7°C, ambient 35°C, full load operation.									

4 Technical specifications

4-4 Electrical Specifications		EWAD-BZXS EWAD-BZXL/EWAD-BZXR	330	360	400	420	460	490	520	
Power Supply	Phase	---	3							
	Frequency	Hz	50							
	Voltage	V	400							
	Voltage Tolerance	Minimum	%	-10%						
		Maximum	%	+10%						
Unit	Maximum starting current	A	232	244	251	278	297	302	316	
	Nominal running current cooling	A	183	209	225	244	256	275	295	
	Maximum running current	A	311		314	344	377			
	Maximum current for wires sizing	A	342		345	378	414			
	Min. displacement power factor at nominal conditions	---	0,98							
Fans	Nominal running current in cooling	A	11,2		14		16,8			
Compressor	Phase	No.	3							
	Voltage	V	400							
	Voltage Tolerance	Minimum	%	-10%						
		Maximum	%	+10%						
	Maximum running current	A	150+150				180+180			
Starting method	---	VFD								
Notes	Allowed voltage tolerance $\pm 10\%$. Voltage unbalance between phases must be within $\pm 3\%$.									
	Maximum starting current: starting current of biggest compressor + current of the compressor at 75% maximum load + fans current for the circuit at 75%.									
	Nominal current in cooling mode is referred to installation with 25kA short circuit current and is based on the following conditions: evaporator 12°C/7°C; ambient 35°C.compressor + fans current.									
	Maximum running current is based on max compressor absorbed current in its envelope and max fans absorbed current									
Maximum current for wires sizing: (compressors full load ampere + fans current) x 1,1.										

5 Sound Levels

EWAD-BZSS / EWAD-BZXS

Unit size	Sound pressure level at 1 m from the unit in semispheric free field (rif. 2×10^{-5} Pa)									Power
	63 Hz	125 Hz	250 Hz	500 Hz	1000 Hz	2000 Hz	4000 Hz	8000 Hz	dB(A)	dB(A)
330	79,1	77,8	79,0	77,6	80,0	76,1	65,6	56,6	83,0	102,8
360	79,1	77,8	79,0	77,6	80,0	76,1	65,6	56,6	83,0	102,8
400	79,1	77,8	79,0	77,6	80,0	76,1	65,6	56,6	83,0	103,2
420	79,1	77,8	79,0	77,6	80,0	76,1	65,6	56,6	83,0	103,2
460	79,6	78,3	79,5	78,1	80,6	76,6	65,6	56,6	83,5	103,6
490	79,6	78,3	79,5	78,1	80,6	76,6	65,6	56,6	83,5	103,6
520	79,6	78,3	79,5	78,1	80,6	76,6	65,6	56,6	83,5	103,6

EWAD-BZSL / EWAD-BZXL

Unit size	Sound pressure level at 1 m from the unit in semispheric free field (rif. 2×10^{-5} Pa)									Power
	63 Hz	125 Hz	250 Hz	500 Hz	1000 Hz	2000 Hz	4000 Hz	8000 Hz	dB(A)	dB(A)
330	78,4	73,5	73,5	71,8	73,9	69,9	59,6	50,7	77,0	96,9
360	78,4	73,5	73,5	71,8	73,9	69,9	59,6	50,7	77,0	96,9
400	78,4	73,5	73,5	71,8	73,9	69,9	59,6	50,7	77,0	97,3
420	78,4	73,5	73,5	71,8	73,9	69,9	59,6	50,7	77,0	97,3
460	78,4	74,0	74,0	72,3	74,4	70,3	60,1	50,7	77,5	98,2
490	78,4	74,0	74,0	72,3	74,4	70,3	60,1	50,7	77,5	98,2
520	78,4	74,0	74,0	72,3	74,4	70,3	60,1	50,7	77,5	98,2

EWAD-BZXR

Unit size	Sound pressure level at 1 m from the unit in semispheric free field (rif. 2×10^{-5} Pa)									Power
	63 Hz	125 Hz	250 Hz	500 Hz	1000 Hz	2000 Hz	4000 Hz	8000 Hz	dB(A)	dB(A)
330	77,0	70,8	70,0	68,0	69,8	65,6	55,6	46,7	73,0	92,9
360	77,0	70,8	70,0	68,0	69,8	65,6	55,6	46,7	73,0	92,9
400	77,0	70,8	70,0	68,0	69,8	65,6	55,6	46,7	73,0	93,3
420	77,0	70,8	70,0	68,0	69,8	65,6	55,6	46,7	73,0	93,3
460	77,3	71,3	70,5	68,7	70,3	66,1	56,0	46,8	73,5	94,2
490	77,3	71,3	70,5	68,7	70,3	66,1	56,0	46,8	73,5	94,2
520	77,3	71,3	70,5	68,7	70,3	66,1	56,0	46,8	73,5	94,2

NOTES

Note: The values are according to ISO 3744 and are referred to: evaporator 12/7° C, air ambient 35° C, full load operation

5 Sound Levels

EWAD-BZ
Sound Pressure and Sound Power attenuation for different compressor load

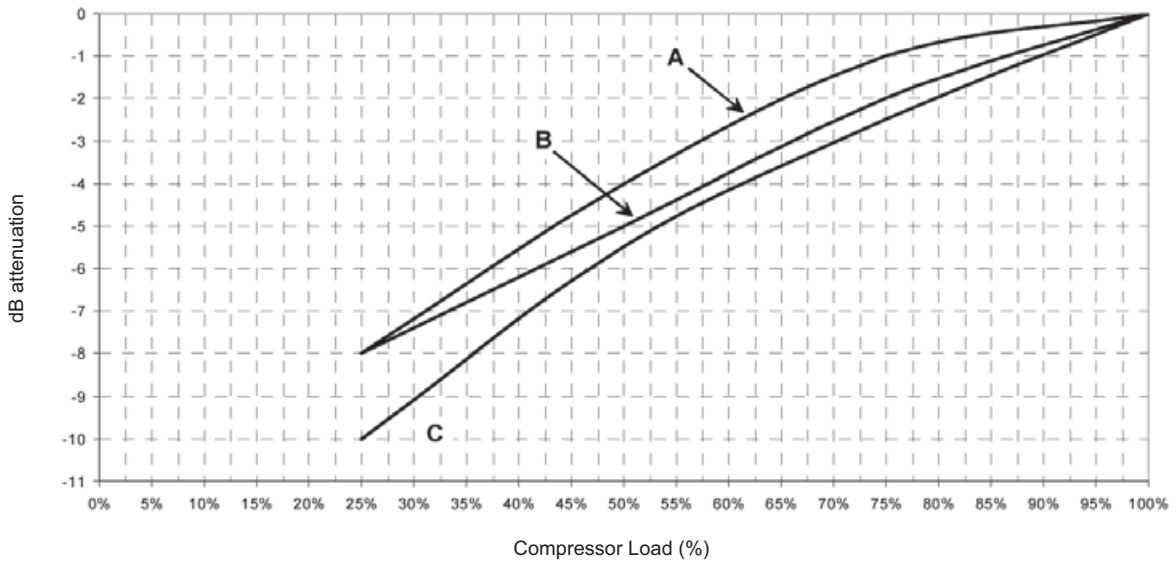

NOTES

Sound pressure in open field conditions on reflecting surface (directivity factor Q=2)

A	EWAD-BZSS / EWAD-BZXS
B	EWAD-BZSL / EWAD-BZXL
C	EWAD-BZXL

5 Sound Levels

Sound pressure level correction factors for different distances

EWAD-BZ

Unit size	Distance					
	1m	5m	10m	15m	20m	25m
330	0,0	-7,7	-12,4	-15,5	-17,7	-19,5
360	0,0	-7,7	-12,4	-15,5	-17,7	-19,5
400	0,0	-7,4	-12,1	-15,1	-17,4	-19,2
420	0,0	-7,4	-12,1	-15,1	-17,4	-19,2
460	0,0	-7,2	-11,8	-14,8	-17,1	-18,8
490	0,0	-7,2	-11,8	-14,8	-17,1	-18,8
520	0,0	-7,2	-11,8	-14,8	-17,1	-18,8

6 Operating limits

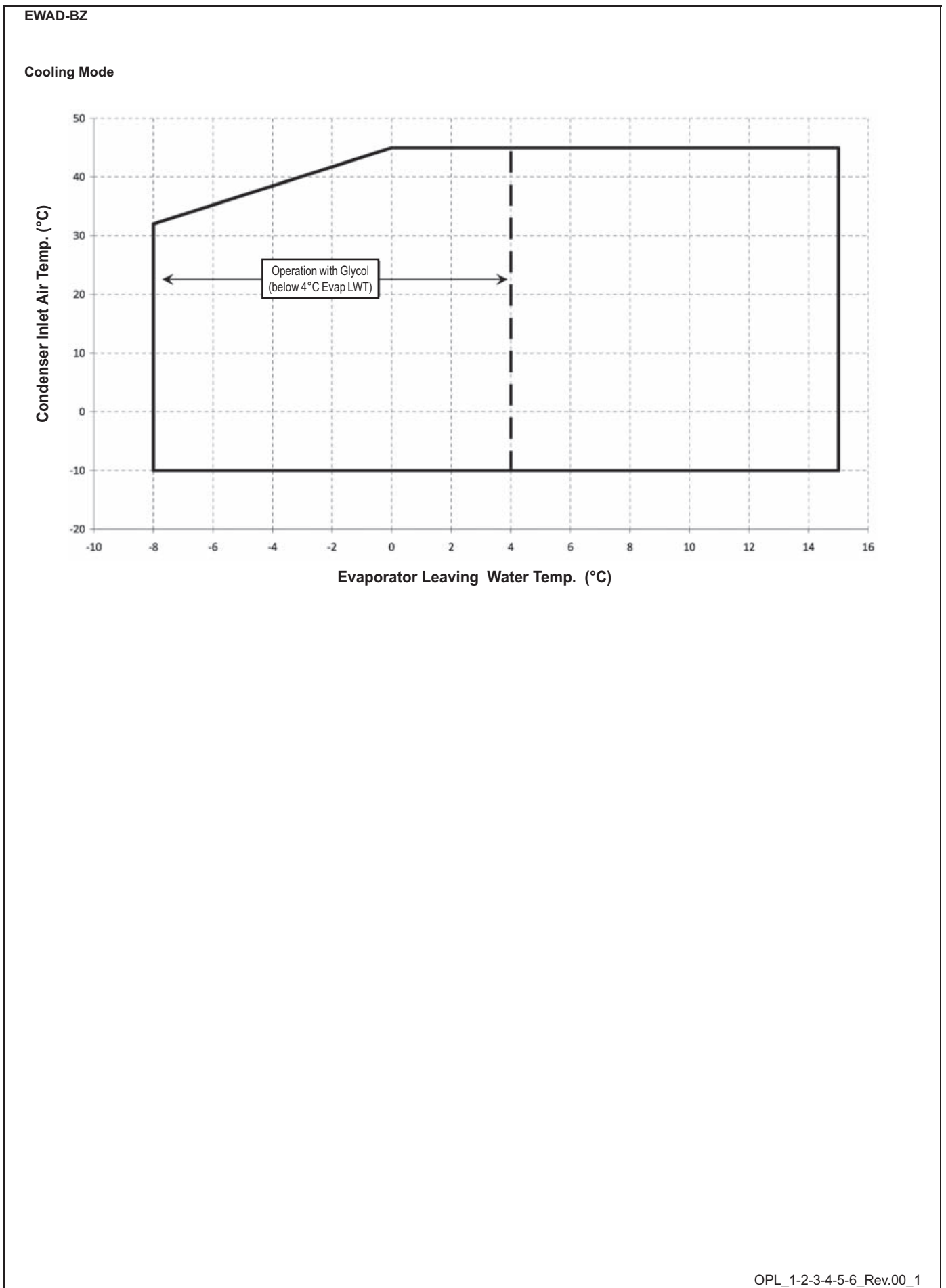

6 Operating limits

EWAD-BZ

Water heat exchanger - Minimum and maximum water Δt

Max evaporator water Δt	°C	8
Min evaporator water Δt	°C	4

Note: Table referred to Cooling and Heating Mode

Water heat exchanger - Fouling factors

Fouling factors m ² °C / kW	Cooling capacity correction factor	Power input correction factor	EER correction factor
0,0176	1,000	1,000	1,000
0,0440	0,978	0,986	0,992
0,0880	0,957	0,974	0,983
0,1320	0,938	0,962	0,975

Note: Table referred to Cooling and Heating Mode

Air heat exchanger - Altitude correction factors

Elevation above sea level (m)	0	300	600	900	1200	1500	1800
Barometric pressure (mbar)	1013	977	942	908	875	843	812
Cooling capacity correction factor	1,000	0,993	0,986	0,979	0,973	0,967	0,960
Power input correction factor	1,000	1,005	1,009	1,015	1,021	1,026	1,031

Note: Table referred to Cooling Mode only

Note: Maximum operating altitude is 2000 m above sea level

Note: Contact factory in case the unit has to be installed at altitudes between 1000 and 2000 m above sea level

Minimum glycol percentage for low water temperature

Evaporator Leaving Water Temperature (°C)	2	0	-2	-4	-6	-8
Ethylene glycol (%)	10	20	20	20	30	30
Propylene glycol (%)	10	20	20	30	30	30

Note: Table referred to Cooling Mode only

Note: Minimum glycol percentage to be used with evaporator leaving water temperature below 4°C to prevent freezing of water circuit.

Minimum glycol percentage for low air ambient temperature

Air Ambient Temperature (°C) (2)	-3	-8	-15	-20
Ethylene glycol (%) (1)	10%	20%	30%	40%
Air Ambient Temperature (°C) (2)	-3	-7	-12	-20
Propylene glycol (%) (1)	10%	20%	30%	40%

Note: Minimum glycol percentage to prevent freezing of water circuit at indicated air ambient temperature

Note: Air ambient temperature do exceed the operating limits of the unit, as protection of water circuit may be needed in winter season at non-working conditions.

Correction factors for low evaporator leaving water temperature

Evaporator Leaving Water Temperature (°C)	2	0	-2	-4	-6	-8
Cooling Capacity	0,842	0,785	0,725	0,670	0,613	0,562
Compressor Power Input	0,950	0,940	0,920	0,890	0,870	0,840

Note: Table referred to Cooling Mode only

Note: Correction factors have to be applied at working conditions: evaporator leaving water temperature 7°C

Correction factors for water and glycol mixture

	Ethylene Glycol (%)	10%	20%	30%	40%	50%
Ethylene Glycol	Cooling Capacity	0,991	0,982	0,972	0,961	0,946
	Compressor Power Input	0,996	0,992	0,986	0,976	0,966
	Flow Rate (Δt)	1,013	1,04	1,074	1,121	1,178
	Evaporator Pressure Drop	1,070	1,129	1,181	1,263	1,308
Propylene Glycol	Cooling Capacity	0,985	0,964	0,932	0,889	0,846
	Compressor Power Input	0,993	0,983	0,969	0,948	0,929
	Flow Rate (Δt)	1,017	1,032	1,056	1,092	1,139
	Evaporator Pressure Drop	1,120	1,272	1,496	1,792	2,128

Note: Table referred to Cooling Mode only

Note: In Heating mode correction factor is 1 at water temperature between operating limits

Note: Contact factory for water temperature out of operating limits

6 Operating limits

How to use the Correction factors proposed in the previous tables

A) Mixture Water and Glycol --- Evaporator leaving water temperature > 4°C

- depending from the type and percentage (%) of glycol filled in the circuit (see table 4.2 and 6)
- multiply the Cooling Capacity, the Compressor Power Input by the Correction factor of Table 6
- starting from this new value of Cooling Capacity, calculate the Flow Rate (l/s) and the Evaporator Pressure Drop (kPa)
- now multiply the new Flow Rate and the new Evaporator Pressure Drop by the Correction Factors of Table 6

Example:

Unit Size: **EWAD330BZSS**

Mixture:	Water
Working condition:	ELWT 12/7°C – Condenser inlet air temperature 35°C
- Cooling capacity:	329 kW (Rated conditions)
- Power input:	120 kW (Rated conditions)
- Flow rate (Δt 5°C):	15.72 l/s
- Evaporator pressure drop:	60 kPa

Mixture:	Water + Ethylene Glycol 30% (for a winter air temperature up to -15°C)
Working condition:	ELWT 12/7°C – Condenser inlet air temperature 35°C
- Cooling capacity:	$329 \times 0.972 = 320$ kW
- Power input:	$120 \times 0.986 = 118$ kW
- Flow rate (Δt 5°C):	15.30 (referred to 320 kW) $\times 1.074 = 16.43$ l/s
- Evaporator pressure drop:	65 (referred to 16.43 l/s) $\times 1.181 = 77$ kPa

B) Mixture Water and Glycol --- Evaporator leaving water temperature < 4°C

- depending from the type and percentage (%) of glycol filled in the circuit (see table 4.1 and 4.2 and table 6)
- depending from the evaporator leaving water temperature (see table 5)
- multiply the Cooling Capacity, the Compressor Power Input by the Correction factor of Table 5 and Table 6
- starting from this new value of Cooling Capacity, calculate the Flow Rate (l/s) and the Evaporator Pressure Drop (kPa)
- now multiply the new Flow Rate and the new Evaporator Pressure Drop by the Correction Factors of Table 6

Example:

Unit Size: **EWAD330BZSS**

Mixture:	Water
Working condition:	ELWT 12/7°C – Condenser inlet air temperature 30°C
- Cooling capacity:	346 kW (Rated conditions)
- Power input:	109 kW (Rated conditions)
- Flow rate (Δt 5°C):	16.53 l/s
- Evaporator pressure drop:	66 kPa

Mixture:	Water + Glycol 30% (for a low evaporator leaving temperature of -1/-6°C)
Working condition:	ELWT -1/-6°C – Condenser inlet air temperature 30°C
- Cooling capacity:	$346 \times 0.613 \times 0.972 = 206$ kW
- Power input:	$109 \times 0.870 \times 0.986 = 93.5$ kW
- Flow rate (Δt 5°C):	9.84 l/s (referred to 206 kW) $\times 1.074 = 10.57$ l/s
- Evaporator pressure drop:	29 kPa (referred to 10.57 l/s) $\times 1.181 = 34$ kPa

6 Operating limits

EWAD-BZ

Items ⁽¹⁾⁽⁵⁾		Cooling Water			Cooled Water		Heated water ⁽²⁾				Tendency if out of criteria	
		Circulating System		Once Flow	Circulating water [Below 20°C]	Supply water ⁽⁴⁾	Low temperature		High temperature			
		Circulating water	Supply water ⁽⁴⁾	Flowing water			Circulating water [20°C ~ 60°C]	Supply water ⁽⁴⁾	Circulating water [60°C ~ 80°C]	Supply water ⁽⁴⁾		
Items to be controlled:	pH	at 25°C	6.5 ~ 8.2	6.0 ~ 8.0	6.0 ~ 8.0	6.0 ~ 8.0	6.0 ~ 8.0	7.0 ~ 8.0	7.0 ~ 8.0	7.0 ~ 8.0	7.0 ~ 8.0	Corrosion + Scale
	Electrical conductivity	[mS/m] at 25°C	Below 80	Below 30	Below 40	Below 40	Below 30	Below 30	Below 30	Below 30	Below 30	Corrosion + Scale
		[µS/cm] at 25°C	(Below 800)	(Below 300)	(Below 400)	(Below 400)	(Below 300)	(Below 300)	(Below 300)	(Below 300)	(Below 300)	Corrosion + Scale
	Chloride ion	[mgCl ⁻ /l]	Below 200	Below 50	Below 50	Below 50	Below 50	Below 50	Below 50	Below 50	Below 50	Corrosion
	Sulfate ion	[mgSO ₄ ²⁻ /l]	Below 200	Below 50	Below 50	Below 50	Below 50	Below 50	Below 50	Below 30	Below 30	Corrosion
	M-alkalinity (pH4.8)	[mgCaCO ₃ /l]	Below 100	Below 50	Below 50	Below 50	Below 50	Below 50	Below 50	Below 50	Below 50	Scale
	Total hardness	[mgCaCO ₃ /l]	Below 200	Below 70	Below 70	Below 70	Below 70	Below 70	Below 70	Below 70	Below 70	Scale
	Calcium hardness	[mgCaCO ₃ /l]	Below 150	Below 50	Below 50	Below 50	Below 50	Below 50	Below 50	Below 50	Below 50	Scale
	Silica ion	[mgSiO ₂ /l]	Below 50	Below 30	Below 30	Below 30	Below 30	Below 30	Below 30	Below 30	Below 30	Scale
Items to be referred to	Iron	[mgFe/l]	Below 1.0	Below 0.3	Below 1.0	Below 1.0	Below 0.3	Below 1.0	Below 0.3	Below 1.0	Below 0.3	Corrosion + Scale
	Copper	[mgCu/l]	Below 0.3	Below 0.1	Below 1.0	Below 1.0	Below 1.0	Below 1.0	Below 0.1	Below 1.0	Below 0.1	Corrosion
	Sulfite ion	[mgS ₂ -/l]	Not detectable	Not detectable	Not detectable	Not detectable	Not detectable	Not detectable	Not detectable	Not detectable	Not detectable	Corrosion
	Ammonium ion	[mgNH ₄ ⁺ /l]	Below 1.0	Below 0.1	Below 1.0	Below 1.0	Below 0.1	Below 0.3	Below 0.1	Below 0.1	Below 0.1	Corrosion
	Remaining chloride	[mgCL/l]	Below 0.3	Below 0.3	Below 0.3	Below 0.3	Below 0.3	Below 0.25	Below 0.3	Below 0.1	Below 0.3	Corrosion
	Free carbide	[mgCO ₃ /l]	Below 4.0	Below 4.0	Below 4.0	Below 4.0	Below 4.0	Below 0.4	Below 4.0	Below 0.4	Below 4.0	Corrosion
	Stability index		6.0 ~ 7.0	---	---	---	---	---	---	---	---	Corrosion + Scale

- Names, definitions and units are according to JIS K 0101. Units and figures between brackets are old units published as reference only.
- In case of using heated water (more than 40°C), corrosion is generally noticeable. Especially when the iron materials is in direct contact with water without any protection shields, it is desirable to give the valid measure for corrosion. E.g. chemical measure
- In the cooling water using hermetic cooling tower, close circuit water is according to heated water standard, and scattered water is according to cooling water standard.
- Supply water is considered drink water, industrial water and ground water except for genuine water, neutral water and soft water.
- The above mentioned items are representable items in corrosion and scale cases.

6 Operating limits

EWAD-BZ

The cooled water distribution circuits should have minimum water content to avoid excessive compressors start and stop. In fact, each time the compressor starts up, an excessive quantity of oil goes from the compressor sump and simultaneously there is a rise in the temperature of the compressor motor's stator due to the inrush current during the start-up. To prevent damage to the compressors, we have envisaged the application of a device to limit frequent stops and restarts.

During the span of one hour there will be no more than 6 starts of the compressor. The plant side should therefore ensure that the overall water content allows a more constant functioning of the unit and consequently greater environmental comfort. The minimum water content per unit should be calculated using this simplified formula:

For 2 compressors unit
M (liters) = (0.1595 x ΔT(°C) + 3.0825) x P(kW)

where:

- M minimum water content per unit expressed in litres
- P Cooling Capacity of the unit expressed in kW
- ΔT evaporator entering / leaving water temperature difference expressed in °C

This formula is valid for:
 - standard microprocessor parameters

For more accurate determination of quantity of water, it is advisable to contact the designer of the plant.

6 Operating limits

EWAD-BZ Automatic and Manual Boost --- Cooling Mode

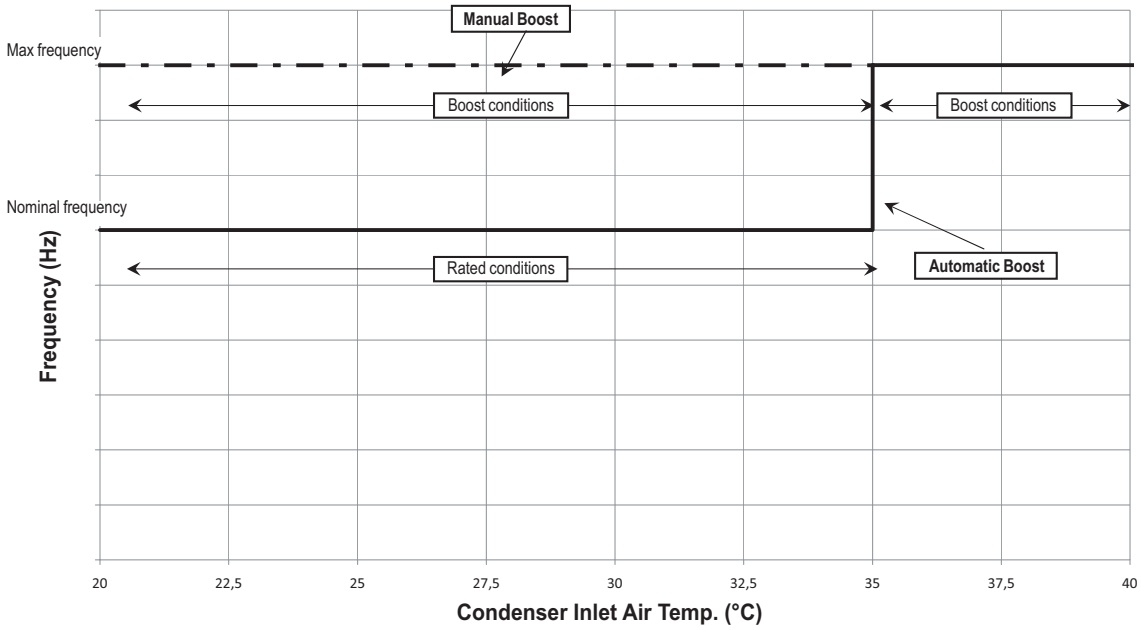

NOTES

1. Automatic boost: unit standard configuration
2. Manual boost: customized configuration by different settings
3. Rated conditions: compressors are working at nominal frequency
4. Boost conditions: compressors are working at the maximum frequency
5. Both automatic and manual boost maximum frequency depends on the maximum current suppliable by the inverter

OPL_1-2-3-4-5-6_Rev.00_6

7 Standard rating

7 - 1 Cooling capacity tables

EWAD-BZSS / EWAD-BZSL

Size		ELWT (°C)		Condenser Inlet Air Temperature (°C)															
				20				25				30				35			
				Rated		Boost		Rated		Boost		Rated		Boost		Rated		Boost	
		Cc (kW)	Pi (kW)	Cc (kW)	Pi (kW)	Cc (kW)	Pi (kW)	Cc (kW)	Pi (kW)	Cc (kW)	Pi (kW)	Cc (kW)	Pi (kW)	Cc (kW)	Pi (kW)	Cc (kW)	Pi (kW)		
330	4	344	86,3	401	110	330	95,7	384	123	315	105	366	136	299	116	346	152		
	5	355	87,2	413	112	341	96,8	396	124	326	107	378	138	309	117	357	153		
	6	366	88,1	425	113	351	97,8	408	125	336	108	389	139	319	119	367	155		
	7	377	89,0	438	114	362	98,8	420	127	346	109	401	141	329	120	378	157		
	8	388	89,9	451	115	373	99,9	433	128	357	110	413	142	339	121	389	158		
	9	400	90,9	464	117	384	101	445	130	368	111	424	144	349	123	401	160		
	10	412	91,8	477	118	396	102	458	131	379	113	436	146	359	124	412	162		
	11	424	92,7	491	120	407	103	471	133	390	114	448	147	370	125	423	164		
	12	436	93,7	505	121	419	104	484	134	401	115	461	149	380	127	435	166		
	13	448	94,6	519	123	431	105	497	136	412	116	473	151	391	128	446	168		
	14	461	95,6	534	124	443	106	511	138	424	118	486	153	402	130	454	167		
	15	474	96,6	549	126	455	108	526	140	435	119	499	155	413	131	462	166		
	360	4	378	97,9	439	126	362	108	420	140	345	119	396	153	326	132	362	160	
		5	390	99,0	452	128	374	110	433	142	356	121	406	153	337	133	371	160	
		6	402	100	466	130	385	111	446	144	368	122	416	153	347	135	382	162	
7		414	101	480	131	397	112	459	146	379	124	428	155	358	136	392	163		
8		426	103	493	133	409	114	472	148	390	125	438	156	369	138	402	163		
9		439	104	507	135	421	115	486	150	402	127	449	156	380	140	413	165		
10		452	105	522	136	434	116	497	150	414	128	459	157	391	142	423	166		
11		465	106	537	138	446	118	508	150	425	130	472	159	402	143	433	166		
12		478	107	551	140	459	119	519	151	437	131	483	159	413	145	445	168		
13		491	109	567	142	472	121	533	153	450	133	493	160	425	147	453	167		
14		505	110	582	144	485	122	545	153	462	135	504	160	436	149	463	168		
15		519	111	597	146	498	123	557	154	474	136	517	162	446	149	471	167		
400		4	414	106	482	136	398	118	462	151	380	129	440	168	360	143	396	171	
		5	427	107	496	138	410	119	476	153	392	131	453	169	371	144	404	169	
		6	440	109	511	139	423	120	490	155	404	132	467	171	383	146	416	171	
	7	454	110	526	141	436	122	505	156	417	134	476	170	395	147	425	170		
	8	467	111	541	143	449	123	519	158	429	135	485	169	407	149	434	169		
	9	481	112	557	144	462	124	534	160	442	137	499	171	419	151	446	171		
	10	495	113	574	146	476	126	549	162	455	138	508	171	431	153	455	170		
	11	510	115	590	148	490	127	565	164	468	140	518	170	444	154	464	169		
	12	524	116	607	150	504	128	581	166	481	142	527	169	456	156	476	171		
	13	539	117	624	152	518	130	597	168	495	143	541	171	469	158	485	170		
	14	554	118	642	154	532	131	614	171	509	145	551	170	482	160	494	169		
	15	570	120	659	156	547	133	624	170	522	147	561	169	495	162	507	171		
	420	4	445	115	518	147	427	127	496	164	408	140	472	182	386	154	424	185	
		5	459	116	533	149	441	128	511	166	421	141	486	184	398	156	435	185	
		6	473	117	549	151	455	130	526	168	434	143	499	185	411	158	444	184	
7		488	119	565	153	468	131	542	170	447	145	511	185	423	159	455	185		
8		503	120	582	155	483	133	558	172	461	146	523	186	436	161	467	185		
9		517	121	599	157	497	134	573	174	475	148	533	185	449	163	476	184		
10		533	123	616	159	511	136	589	176	488	150	543	184	462	165	487	184		
11		548	124	633	161	526	137	606	178	502	152	558	186	475	167	499	185		
12		563	125	651	163	541	139	623	181	517	153	568	185	489	169	508	184		
13		579	127	669	165	556	141	640	183	531	155	578	184	502	171	520	184		
14		595	128	688	167	572	142	654	184	546	157	590	185	516	173	531	185		
15		612	130	706	170	587	144	668	185	560	159	604	186	530	175	541	184		

NOTES

Cc (cooling capacity) - Pi (unit power input) – ELWT (evaporator leaving water temperature – Δt 5°C).
 Data are referred to 0,0176 m² °C/kW evaporator fouling factor
 Rated conditions are for compressors running at nominal frequency.
 Boost conditions are for compressors running at maximum frequency.

7 Standard rating

7 - 1 Cooling capacity tables

EWAD-BZSS / EWAD-BZSL

Size	ELWT (°C)	Condenser Inlet Air Temperature (°C)												
		36				40				45				
		Rated		Boost		Rated		Boost		Rated		Boost		
		Cc (kW)	Pi (kW)	Cc (kW)	Pi (kW)	Cc (kW)	Pi (kW)	Cc (kW)	Pi (kW)	Cc (kW)	Pi (kW)	Cc (kW)	Pi (kW)	
330	4	340	155	340	155	319	167	319	167	267	155	267	155	
	5	351	156	351	156	329	169	329	169	271	151	271	151	
	6	361	157	361	157	336	168	336	168	275	147	275	147	
	7	371	159	371	159	343	166	343	166	279	142	279	142	
	8	382	160	382	160	353	168	353	168	283	138	283	138	
	9	392	162	392	162	360	167	360	167	286	134	286	134	
	10	403	163	403	163	370	169	370	169	290	131	290	131	
	11	414	165	414	165	377	167	377	167	293	127	293	127	
	12	425	166	425	166	385	166	385	166	296	123	296	123	
	13	436	168	436	168	395	168	395	168	299	119	299	119	
	14	443	167	443	167	402	167	402	167	305	118	305	118	
	15	450	165	450	165	406	163	406	163	307	115	307	115	
	360	4	354	162	354	162	325	167	325	167	270	150	270	150
		5	364	162	364	162	334	168	334	168	274	146	274	146
		6	374	163	374	163	343	168	343	168	278	141	278	141
7		384	163	384	163	350	167	350	167	283	138	283	138	
8		393	164	393	164	361	169	361	169	286	134	286	134	
9		404	166	404	166	368	167	368	167	290	130	290	130	
10		414	166	414	166	377	168	377	168	293	126	293	126	
11		424	166	424	166	386	168	386	168	297	123	297	123	
12		434	168	434	168	393	167	393	167	301	121	301	121	
13		442	167	442	167	401	166	401	166	303	117	303	117	
14		452	167	452	167	407	163	407	163	307	114	307	114	
15		459	165	459	165	411	158	411	158	308	110	308	110	
400		4	386	171	386	171	349	170	349	170	296	159	296	159
		5	395	169	395	169	357	169	357	169	306	161	306	161
		6	407	171	407	171	368	171	368	171	313	160	313	160
	7	415	170	415	170	376	170	376	170	323	161	323	161	
	8	424	170	424	170	387	171	387	171	330	160	330	160	
	9	436	171	436	171	396	170	396	170	334	155	334	155	
	10	445	170	445	170	404	169	404	169	338	151	338	151	
	11	454	169	454	169	415	171	415	171	342	146	342	146	
	12	466	171	466	171	423	170	423	170	345	142	345	142	
	13	475	170	475	170	431	168	431	168	348	137	348	137	
	14	484	169	484	169	443	170	443	170	355	136	355	136	
	15	496	171	496	171	452	169	452	169	357	132	357	132	
	420	4	414	185	414	185	373	184	373	184	318	174	318	174
		5	425	185	425	185	384	185	384	185	324	170	324	170
		6	434	184	434	184	394	185	394	185	331	169	331	169
7		445	185	445	185	404	185	404	185	337	165	337	165	
8		456	185	456	185	413	184	413	184	345	164	345	164	
9		466	184	466	184	425	186	425	186	349	159	349	159	
10		477	184	477	184	434	185	434	185	353	154	353	154	
11		488	185	488	185	442	183	442	183	356	149	356	149	
12		498	184	498	184	455	186	455	186	361	146	361	146	
13		508	184	508	184	464	184	464	184	366	143	366	143	
14		520	185	520	185	474	185	474	185	369	138	369	138	
15		530	184	530	184	485	185	485	185	371	134	371	134	

NOTES

Cc (cooling capacity) - Pi (unit power input) - ELWT (evaporator leaving water temperature - Δt 5°C).
 Data are referred to 0,0176 m² °C/kW evaporator fouling factor
 Rated conditions are for compressors running at nominal frequency.
 Boost conditions are for compressors running at maximum frequency.

7 Standard rating

7 - 1 Cooling capacity tables

EWAD-BZSS / EWAD-BZSL

Size	ELWT (°C)	Condenser Inlet Air Temperature (°C)																
		20				25				30				35				
		Rated		Boost		Rated		Boost		Rated		Boost		Rated		Boost		
		Cc (kW)	Pi (kW)	Cc (kW)	Pi (kW)	Cc (kW)	Pi (kW)	Cc (kW)	Pi (kW)	Cc (kW)	Pi (kW)	Cc (kW)	Pi (kW)	Cc (kW)	Pi (kW)	Cc (kW)	Pi (kW)	
460	4	480	121	560	154	461	134	537	172	441	148	512	190	418	162	469	201	
	5	496	122	577	156	476	136	553	174	455	149	528	192	431	164	484	203	
	6	511	124	594	158	491	137	570	175	469	151	544	195	445	166	494	202	
	7	527	125	611	160	506	139	587	177	484	153	560	197	459	168	504	200	
	8	542	126	629	162	521	140	604	180	499	154	576	199	473	170	519	203	
	9	559	127	647	164	537	141	622	182	514	156	592	201	487	172	529	201	
	10	575	129	666	165	553	143	639	184	529	158	609	204	502	174	544	204	
	11	592	130	686	168	569	145	657	186	544	159	620	203	516	176	555	202	
	12	609	131	705	170	585	146	676	188	560	161	631	202	531	178	565	201	
	13	626	133	726	172	602	148	695	191	576	163	642	200	546	180	581	203	
	14	644	134	746	174	619	149	714	193	592	165	660	203	561	182	591	202	
	15	661	135	767	176	636	151	734	196	608	167	671	202	576	184	602	201	
	490	4	512	130	596	166	491	144	571	185	469	159	531	196	445	175	480	201
		5	528	131	614	168	507	146	589	187	485	160	547	198	459	177	495	203
		6	544	133	632	170	523	147	606	189	500	162	561	199	474	179	505	202
7		561	134	651	172	539	149	621	190	515	164	575	199	488	181	516	200	
8		578	136	670	174	555	150	636	190	531	166	591	202	503	183	531	203	
9		595	137	689	177	572	152	654	193	547	168	606	202	518	185	542	201	
10		612	139	709	179	589	154	669	193	563	170	617	201	533	187	555	202	
11		630	140	730	181	606	156	685	194	579	171	634	203	549	189	568	202	
12		648	142	751	183	623	157	704	196	595	173	646	202	562	189	579	201	
13		667	143	772	186	640	159	720	197	612	175	657	201	577	192	592	202	
14		686	145	793	188	658	161	737	198	629	177	672	202	590	192	606	202	
15		705	146	811	189	677	163	754	198	646	179	687	203	604	192	616	201	
520		4	541	139	628	178	519	154	603	198	496	169	547	201	470	187	488	201
		5	558	140	647	180	536	155	621	200	512	171	563	204	485	189	503	203
		6	575	142	667	182	552	157	639	203	528	173	575	203	500	191	514	202
	7	592	143	686	185	569	159	652	202	544	175	587	201	515	193	525	200	
	8	610	145	706	187	586	161	664	201	560	177	604	204	531	195	541	203	
	9	628	147	728	189	604	163	683	203	577	179	616	203	547	198	551	201	
	10	646	148	749	192	621	164	696	202	594	181	627	201	562	200	567	204	
	11	665	150	771	194	639	166	709	201	611	183	645	204	578	202	578	202	
	12	684	151	793	197	657	168	729	204	628	185	657	203	590	201	590	201	
	13	703	153	815	199	676	170	743	203	645	188	669	201	606	203	606	203	
	14	724	155	837	202	694	172	756	202	663	190	681	200	617	202	617	202	
	15	745	157	852	201	714	174	770	201	681	192	699	203	628	200	628	200	

NOTES

Cc (cooling capacity) - Pi (unit power input) – ELWT (evaporator leaving water temperature – Δt 5°C).
 Data are referred to 0,0176 m² °C/kW evaporator fouling factor
 Rated conditions are for compressors running at nominal frequency.
 Boost conditions are for compressors running at maximum frequency.

7 Standard rating

7 - 1 Cooling capacity tables

EWAD-BZSS / EWAD-BZSL

Size	ELWT (°C)	Condenser Inlet Air Temperature (°C)												
		36				40				45				
		Rated		Boost		Rated		Boost		Rated		Boost		
		Cc (kW)	Pi (kW)	Cc (kW)	Pi (kW)	Cc (kW)	Pi (kW)	Cc (kW)	Pi (kW)	Cc (kW)	Pi (kW)	Cc (kW)	Pi (kW)	
460	4	458	201	458	201	414	201	414	201	354	193	354	193	
	5	473	203	473	203	427	203	427	203	362	191	362	191	
	6	482	202	482	202	437	201	437	201	374	193	374	193	
	7	493	201	493	201	450	204	450	204	383	191	383	191	
	8	507	202	507	202	459	202	459	202	395	193	395	193	
	9	517	201	517	201	469	201	469	201	400	188	400	188	
	10	532	203	532	203	483	203	483	203	405	182	405	182	
	11	542	202	542	202	492	201	492	201	409	177	409	177	
	12	553	202	553	202	506	204	506	204	414	172	414	172	
	13	568	203	568	203	516	202	516	202	418	167	418	167	
	14	578	202	578	202	526	201	526	201	421	162	421	162	
	15	589	201	589	201	540	203	540	203	429	160	429	160	
	490	4	469	201	469	201	425	202	425	202	364	192	364	192
		5	483	203	483	203	437	202	437	202	372	191	372	191
		6	494	202	494	202	449	203	449	203	384	193	384	193
7		504	201	504	201	459	201	459	201	393	191	393	191	
8		519	202	519	202	470	201	470	201	404	191	404	191	
9		530	201	530	201	482	202	482	202	411	187	411	187	
10		543	202	543	202	494	202	494	202	421	188	421	188	
11		556	202	556	202	506	203	506	203	426	182	426	182	
12		566	201	566	201	516	201	516	201	433	179	433	179	
13		579	202	579	202	528	201	528	201	437	173	437	173	
14		593	202	593	202	541	202	541	202	440	168	440	168	
15		604	201	604	201	553	202	553	202	444	162	444	162	
520		4	477	201	477	201	435	203	435	203	372	192	372	192
		5	492	203	492	203	445	201	445	201	381	190	381	190
		6	503	202	503	202	459	204	459	204	393	192	393	192
	7	514	201	514	201	469	202	469	202	402	190	402	190	
	8	528	202	528	202	479	200	479	200	415	193	415	193	
	9	540	201	540	201	494	203	494	203	424	191	424	191	
	10	555	203	555	203	504	201	504	201	437	193	437	193	
	11	566	202	566	202	518	203	518	203	441	187	441	187	
	12	577	201	577	201	528	202	528	202	450	185	450	185	
	13	592	203	592	203	539	200	539	200	454	179	454	179	
	14	604	202	604	202	554	202	554	202	458	174	458	174	
	15	615	200	615	200	564	201	564	201	461	168	461	168	

NOTES

Cc (cooling capacity) - Pi (unit power input) – ELWT (evaporator leaving water temperature – Δt 5°C).
 Data are referred to 0,0176 m² °C/kW evaporator fouling factor
 Rated conditions are for compressors running at nominal frequency.
 Boost conditions are for compressors running at maximum frequency.

7 Standard rating

7 - 1 Cooling capacity tables

EWAD-BZXS / EWAD-BZXL / EWAD-BZXR

Size	ELWT (°C)	Condenser Inlet Air Temperature (°C)																
		20				25				30				35				
		Rated		Boost		Rated		Boost		Rated		Boost		Rated		Boost		
	Cc (kW)	Pi (kW)	Cc (kW)	Pi (kW)	Cc (kW)	Pi (kW)	Cc (kW)	Pi (kW)	Cc (kW)	Pi (kW)	Cc (kW)	Pi (kW)	Cc (kW)	Pi (kW)	Cc (kW)	Pi (kW)		
330	4	344	84,4	401	108	330	94	384	121	315	104	366	134	299	114	346	150	
	5	355	85,3	413	110	341	95	396	122	326	105	378	136	309	116	357	151	
	6	366	86,2	425	111	351	96	408	124	336	106	389	137	319	117	367	153	
	7	377	87,1	438	112	362	97	420	125	346	107	401	139	329	118	378	155	
	8	388	88,0	451	114	373	98	433	126	357	108	413	140	339	119	389	157	
	9	400	89,0	464	115	384	99	445	128	368	109	424	142	349	121	397	156	
	10	412	89,9	477	116	396	100	458	130	379	111	436	144	359	122	404	155	
	11	424	90,8	491	118	407	101	471	131	390	112	448	146	370	124	416	157	
	12	436	91,8	505	119	419	102	484	133	401	113	461	147	380	125	423	156	
	13	448	92,7	519	121	431	104	497	134	412	115	473	149	391	127	431	155	
	14	461	93,7	534	122	443	105	511	136	424	116	486	151	402	128	442	156	
	15	474	94,7	549	124	455	106	526	138	435	117	499	153	413	130	450	156	
	360	4	378	96,0	439	124	362	106	420	138	345	117	396	151	326	130	362	158
		5	390	97,1	452	126	374	108	433	140	356	119	406	151	337	131	371	159
		6	402	98,3	466	128	385	109	446	142	368	120	416	152	347	133	382	161
7		414	99,4	480	129	397	110	459	144	379	122	428	153	358	135	392	161	
8		426	101	493	131	409	112	472	146	390	123	438	154	369	136	402	161	
9		439	102	507	133	421	113	486	148	402	125	449	154	380	138	413	163	
10		452	103	522	135	434	114	497	148	414	126	459	155	391	140	423	164	
11		465	104	537	136	446	116	508	148	425	128	472	157	402	141	433	164	
12		478	106	551	138	459	117	519	149	437	130	483	157	413	143	445	166	
13		491	107	567	140	472	119	533	151	450	131	493	158	425	145	453	165	
14		505	108	582	142	485	120	545	151	462	133	504	158	436	147	463	166	
15		519	109	597	144	498	122	557	152	474	135	517	160	446	147	471	165	
400		4	414	104	482	133	398	115	462	148	380	127	440	165	360	140	396	168
		5	427	105	496	135	410	116	476	150	392	128	453	167	371	142	404	167
		6	440	106	511	137	423	118	490	152	404	130	467	169	383	143	416	169
	7	454	107	526	138	436	119	505	154	417	131	476	168	395	145	425	168	
	8	467	108	541	140	449	120	519	156	429	133	485	167	407	147	434	167	
	9	481	110	557	142	462	122	534	158	442	134	499	169	419	148	446	169	
	10	495	111	574	144	476	123	549	160	455	136	508	168	431	150	455	168	
	11	510	112	590	146	490	125	565	162	468	138	518	167	444	152	464	166	
	12	524	113	607	147	504	126	581	164	481	139	527	166	456	154	476	168	
	13	539	114	624	149	518	127	597	166	495	141	541	168	469	156	485	167	
	14	554	116	642	151	532	129	614	168	509	142	551	167	482	157	494	166	
	15	570	117	659	153	547	130	624	167	522	144	561	167	495	159	507	168	
	420	4	445	112	518	145	427	124	496	161	408	137	472	179	386	151	424	182
		5	459	113	533	147	441	126	511	163	421	139	486	181	398	153	435	183
		6	473	115	549	148	455	127	526	165	434	140	499	182	411	155	444	182
7		488	116	565	150	468	129	542	167	447	142	511	182	423	157	455	182	
8		503	117	582	152	483	130	558	169	461	144	523	183	436	159	467	183	
9		517	119	599	154	497	132	573	171	475	145	533	182	449	161	476	182	
10		533	120	616	156	511	133	589	174	488	147	543	181	462	163	487	182	
11		548	121	633	158	526	135	606	176	502	149	558	184	475	165	499	183	
12		563	123	651	160	541	137	623	178	517	151	568	183	489	167	508	181	
13		579	124	669	163	556	138	640	181	531	153	578	182	502	169	520	182	
14		595	126	688	165	572	140	654	182	546	155	590	182	516	171	531	183	
15		612	127	706	167	587	141	668	182	560	156	604	183	530	173	541	182	

NOTES

Cc (cooling capacity) - Pi (unit power input) – ELWT (evaporator leaving water temperature – Δt 5°C).
 Data are referred to 0,0176 m² °C/kW evaporator fouling factor
 Rated conditions are for compressors running at nominal frequency.
 Boost conditions are for compressors running at maximum frequency.

7 Standard rating

7 - 1 Cooling capacity tables

EWAD-BZXS / EWAD-BZXL / EWAD-BZXR

Size	ELWT (°C)	Condenser Inlet Air Temperature (°C)												
		36				40				45				
		Rated		Boost		Rated		Boost		Rated		Boost		
		Cc (kW)	Pi (kW)	Cc (kW)	Pi (kW)	Cc (kW)	Pi (kW)	Cc (kW)	Pi (kW)	Cc (kW)	Pi (kW)	Cc (kW)	Pi (kW)	
330	4	340	153	340	153	319	165	319	165	267	154	267	154	
	5	351	155	351	155	329	167	329	167	271	149	271	149	
	6	361	156	361	156	336	166	336	166	275	145	275	145	
	7	371	157	371	157	343	164	343	164	279	141	279	141	
	8	382	159	382	159	353	166	353	166	283	137	283	137	
	9	389	157	389	157	360	165	360	165	286	133	286	133	
	10	397	157	397	157	370	167	370	167	290	129	290	129	
	11	408	158	408	158	377	166	377	166	293	125	293	125	
	12	415	157	415	157	385	164	385	164	296	121	296	121	
	13	424	157	424	157	395	166	395	166	299	118	299	118	
	14	434	158	434	158	402	165	402	165	305	116	305	116	
	15	441	157	441	157	406	161	406	161	307	113	307	113	
	360	4	354	160	354	160	325	165	325	165	270	148	270	148
		5	364	160	364	160	334	166	334	166	274	144	274	144
		6	374	162	374	162	343	166	343	166	278	139	278	139
7		384	162	384	162	350	165	350	165	283	137	283	137	
8		393	162	393	162	361	167	361	167	286	132	286	132	
9		404	164	404	164	368	165	368	165	290	128	290	128	
10		414	164	414	164	377	166	377	166	293	124	293	124	
11		424	165	424	165	386	166	386	166	297	122	297	122	
12		434	166	434	166	393	165	393	165	301	119	301	119	
13		442	165	442	165	401	164	401	164	303	115	303	115	
14		452	165	452	165	407	161	407	161	307	112	307	112	
15		459	163	459	163	411	157	411	157	308	108	308	108	
400		4	386	168	386	168	349	168	349	168	296	157	296	157
		5	395	167	395	167	357	166	357	166	306	159	306	159
		6	407	169	407	169	368	168	368	168	313	157	313	157
	7	415	168	415	168	376	167	376	167	323	159	323	159	
	8	424	167	424	167	387	169	387	169	330	157	330	157	
	9	436	168	436	168	396	168	396	168	334	153	334	153	
	10	445	167	445	167	404	166	404	166	338	148	338	148	
	11	454	167	454	167	415	168	415	168	342	144	342	144	
	12	466	168	466	168	423	167	423	167	345	139	345	139	
	13	475	167	475	167	431	166	431	166	348	135	348	135	
	14	484	167	484	167	443	168	443	168	355	133	355	133	
	15	496	168	496	168	452	167	452	167	357	129	357	129	
	420	4	414	182	414	182	373	182	373	182	318	172	318	172
		5	425	183	425	183	384	182	384	182	324	168	324	168
		6	434	182	434	182	394	182	394	182	331	166	331	166
7		445	182	445	182	404	183	404	183	337	163	337	163	
8		456	182	456	182	413	182	413	182	345	161	345	161	
9		466	182	466	182	425	184	425	184	349	156	349	156	
10		477	182	477	182	434	182	434	182	353	151	353	151	
11		488	182	488	182	442	181	442	181	356	147	356	147	
12		498	182	498	182	455	183	455	183	361	143	361	143	
13		508	182	508	182	464	182	464	182	366	140	366	140	
14		520	183	520	183	474	182	474	182	369	136	369	136	
15		530	182	530	182	485	183	485	183	371	131	371	131	

NOTES

Cc (cooling capacity) - Pi (unit power input) – ELWT (evaporator leaving water temperature – Δt 5°C).
 Data are referred to 0,0176 m² °C/kW evaporator fouling factor
 Rated conditions are for compressors running at nominal frequency.
 Boost conditions are for compressors running at maximum frequency.

7 Standard rating

7 - 1 Cooling capacity tables

EWAD-BZXS / EWAD-BZXL / EWAD-BZXR

Size	ELWT (°C)	Condenser Inlet Air Temperature (°C)																
		20				25				30				35				
		Rated		Boost		Rated		Boost		Rated		Boost		Rated		Boost		
		Cc (kW)	Pi (kW)	Cc (kW)	Pi (kW)	Cc (kW)	Pi (kW)	Cc (kW)	Pi (kW)	Cc (kW)	Pi (kW)	Cc (kW)	Pi (kW)	Cc (kW)	Pi (kW)	Cc (kW)	Pi (kW)	
460	4	480	118	560	152	461	131	537	169	441	145	512	187	418	160	469	198	
	5	496	119	577	153	476	133	553	171	455	146	528	189	431	161	484	200	
	6	511	121	594	155	491	134	570	173	469	148	544	192	445	163	494	199	
	7	527	122	611	157	506	136	587	175	484	150	560	194	459	165	504	197	
	8	542	123	629	159	521	137	604	177	499	151	576	196	473	167	519	200	
	9	559	125	647	161	537	139	622	179	514	153	592	198	487	169	529	198	
	10	575	126	666	163	553	140	639	181	529	155	609	201	502	171	544	201	
	11	592	127	686	165	569	142	657	183	544	156	620	200	516	173	555	199	
	12	609	129	705	167	585	143	676	185	560	158	631	199	531	175	565	198	
	13	626	130	726	169	602	145	695	188	576	160	642	198	546	177	581	201	
	14	644	131	746	171	619	146	714	190	592	162	660	200	561	179	591	199	
	15	661	133	767	173	636	148	734	193	608	164	671	199	576	181	602	198	
	490	4	512	127	596	164	491	141	571	182	469	156	531	193	445	172	480	198
		5	528	128	614	165	507	143	589	184	485	157	547	195	459	174	495	200
		6	544	130	632	167	523	144	606	186	500	159	561	196	474	176	505	199
7		561	131	651	169	539	146	621	187	515	161	575	196	488	178	516	198	
8		578	133	670	172	555	148	636	187	531	163	591	199	503	180	531	200	
9		595	134	689	174	572	149	654	190	547	165	606	199	518	182	542	199	
10		612	136	709	176	589	151	669	190	563	167	617	198	533	184	555	199	
11		630	137	730	178	606	153	685	191	579	169	634	201	549	186	568	200	
12		648	139	751	180	623	154	704	193	595	171	646	199	562	186	579	198	
13		667	140	772	183	640	156	720	194	612	173	657	198	577	189	592	199	
14		686	142	793	185	658	158	737	195	629	175	672	199	590	189	606	199	
15		705	143	811	186	677	160	754	195	646	177	687	200	604	189	616	198	
520		4	541	136	628	175	519	151	603	195	496	166	547	199	470	184	488	198
		5	558	137	647	177	536	153	621	197	512	168	563	201	485	186	503	200
		6	575	139	667	179	552	154	639	200	528	170	575	200	500	188	514	199
	7	592	140	686	182	569	156	652	199	544	172	587	198	515	190	525	197	
	8	610	142	706	184	586	158	664	198	560	174	604	201	531	192	541	200	
	9	628	144	728	186	604	160	683	200	577	176	616	200	547	195	551	198	
	10	646	145	749	189	621	161	696	199	594	178	627	199	562	197	567	201	
	11	665	147	771	191	639	163	709	198	611	180	645	201	578	199	578	199	
	12	684	149	793	194	657	165	729	201	628	183	657	200	590	198	590	198	
	13	703	150	815	196	676	167	743	200	645	185	669	199	606	200	606	200	
	14	724	152	837	199	694	169	756	199	663	187	681	197	617	199	617	199	
	15	745	154	852	198	714	171	770	198	681	189	699	200	628	198	628	198	

NOTES

Cc (cooling capacity) - Pi (unit power input) – ELWT (evaporator leaving water temperature – Δt 5°C).
 Data are referred to 0,0176 m² °C/kW evaporator fouling factor
 Rated conditions are for compressors running at nominal frequency.
 Boost conditions are for compressors running at maximum frequency.

7 Standard rating

7 - 1 Cooling capacity tables

EWAD-BZXS / EWAD-BZXL / EWAD-BZXR

Size	ELWT (°C)	Condenser Inlet Air Temperature (°C)												
		36				40				45				
		Rated		Boost		Rated		Boost		Rated		Boost		
		Cc (kW)	Pi (kW)	Cc (kW)	Pi (kW)	Cc (kW)	Pi (kW)	Cc (kW)	Pi (kW)	Cc (kW)	Pi (kW)	Cc (kW)	Pi (kW)	
460	4	458	198	458	198	414	198	414	198	354	190	354	190	
	5	473	200	473	200	427	200	427	200	362	188	362	188	
	6	482	199	482	199	437	199	437	199	374	190	374	190	
	7	493	198	493	198	450	201	450	201	383	188	383	188	
	8	507	200	507	200	459	199	459	199	395	190	395	190	
	9	517	198	517	198	469	198	469	198	400	185	400	185	
	10	532	201	532	201	483	200	483	200	405	179	405	179	
	11	542	199	542	199	492	199	492	199	409	174	409	174	
	12	553	199	553	199	506	201	506	201	414	169	414	169	
	13	568	200	568	200	516	199	516	199	418	164	418	164	
	14	578	199	578	199	526	198	526	198	421	159	421	159	
	15	589	198	589	198	540	200	540	200	429	157	429	157	
	490	4	469	198	469	198	425	199	425	199	364	192	364	192
		5	483	200	483	200	437	199	437	199	372	191	372	191
		6	494	199	494	199	449	200	449	200	384	193	384	193
7		504	198	504	198	459	198	459	198	393	191	393	191	
8		519	200	519	200	470	198	470	198	404	191	404	191	
9		530	199	530	199	482	199	482	199	411	187	411	187	
10		543	199	543	199	494	199	494	199	421	188	421	188	
11		556	200	556	200	506	200	506	200	426	182	426	182	
12		566	198	566	198	516	198	516	198	433	179	433	179	
13		579	199	579	199	528	199	528	199	437	173	437	173	
14		593	199	593	199	541	199	541	199	440	168	440	168	
15		604	198	604	198	553	199	553	199	444	162	444	162	
520		4	477	198	477	198	435	200	435	200	372	189	372	189
		5	492	200	492	200	445	198	445	198	381	187	381	187
		6	503	199	503	199	459	201	459	201	393	189	393	189
	7	514	198	514	198	469	199	469	199	402	188	402	188	
	8	528	199	528	199	479	197	479	197	415	190	415	190	
	9	540	198	540	198	494	200	494	200	424	188	424	188	
	10	555	200	555	200	504	198	504	198	437	190	437	190	
	11	566	199	566	199	518	200	518	200	441	184	441	184	
	12	577	198	577	198	528	199	528	199	450	182	450	182	
	13	592	200	592	200	539	197	539	197	454	177	454	177	
	14	604	199	604	199	554	200	554	200	458	171	458	171	
	15	615	198	615	198	564	198	564	198	461	165	461	165	

NOTES

Cc (cooling capacity) - Pi (unit power input) – ELWT (evaporator leaving water temperature – Δt 5°C).
 Data are referred to 0,0176 m² °C/kW evaporator fouling factor.
 Rated conditions are for compressors running at nominal frequency.
 Boost conditions are for compressors running at maximum frequency.

8 Evaporator pressure drop

EWAD-BZ

	330	360	400	420	460	490	520
Cooling Capacity (kW)	329	358	395	423	459	488	515
Water Flow (l/s)	15,72	17,10	18,87	20,21	21,93	23,32	24,61
Pressure Drops (kPa)	60	61	72	67	78	69	76

Water flow and pressure drop referred to nominal condition: evaporator water in/out: 12/7°C – condenser air inlet: 35°C

EPD_1-2_Rev.00_1

EWAD-BZ

To determine the pressure drop for different versions or at different working conditions, please refer to the following formula:

$$PD_2 \text{ (kPa)} = PD_1 \text{ (kPa)} \times \left(\frac{Q_2 \text{ (l/s)}}{Q_1 \text{ (l/s)}} \right)^{1.8}$$

where:

PD_2 Pressure drop to be determinate (kPa)

PD_1 Pressure drop at nominal condition (kPa)

Q_2 water flow at new working condition (l/s)

Q_1 water flow at nominal condition (l/s)

How to use the formula: Example

The unit EWAD330BZSS has been selected for working at the following conditions:

- evaporator water in/out : 11/6°C

- condenser air inlet: 30°C

The cooling capacity at these working conditions is: 336 kW (Rated conditions)

The water flow at these working conditions is: 16.05 l/s (Rated conditions)

The unit EWAD330BZSS at nominal working conditions has the following data:

- evaporator water in/out : 12/7°C

- condenser air inlet: 35°C

The cooling capacity at these working conditions is: 329 kW

The water flow at these working conditions is: 15.72 l/s

The pressure drop at these working conditions is: 60 kPa

The pressure drop at the selected working condition will be:

$$PD_2 \text{ (kPa)} = 60 \text{ (kPa)} \times \left(\frac{16.05 \text{ (l/s)}}{15.72 \text{ (l/s)}} \right)^{1.8}$$

$$PD_2 \text{ (kPa)} = 62 \text{ (kPa)}$$

NOTE - Important

If the calculated evaporator water pressure drop is below 10 kPa or above 100 kPa, please contact the factory for dedicated evaporator.

EPD_1-2_Rev.00_2

9 Options

EWAD-BZ

Size		ELWT (°C)	Condenser Inlet Air Temperature (°C)														
			30/35			35/40			40/45			45/50			50/55		
			Rated			Rated			Rated			Rated			Rated		
		Cc (kW)	Pi (kW)	Hc (kW)	Cc (kW)	Pi (kW)	Hc (kW)	Cc (kW)	Pi (kW)	Hc (kW)	Cc (kW)	Pi (kW)	Hc (kW)	Cc (kW)	Pi (kW)	Hc (kW)	
330	4	321	84.5	405	305	93.9	399	287	105	392	266	118	383	178	82.7	261	
	5	331	85.3	417	315	94.8	410	297	106	402	275	119	394	179	80.2	260	
	6	342	86.1	428	326	95.7	421	307	107	413	284	120	404	180	77.8	258	
	7	353	86.9	440	336	96.6	433	317	108	424	294	121	414	184	77.0	261	
	8	365	87.7	452	347	97.5	445	327	109	436	303	122	425	184	74.6	258	
	9	376	88.5	464	358	98.4	456	337	110	447	313	123	436	187	73.9	261	
	10	388	89.3	477	369	99.3	468	348	111	459	323	124	447	186	71.5	258	
	11	399	90.1	489	380	100	481	359	112	470	333	125	459	189	70.7	259	
	12	411	90.9	502	392	101	493	370	113	482	344	126	470	191	69.9	261	
	13	423	91.7	515	403	102	506	381	114	494	351	125	476	189	67.4	257	
	14	436	92.5	528	415	103	518	392	115	507	354	122	476	191	66.6	258	
	15	448	93.3	542	427	104	531	403	116	519	358	119	477	193	65.7	259	
	360	4	356	94.2	450	338	105	442	317	117	434	293	131	425	187	85.9	273
		5	367	95.1	462	349	106	455	328	118	446	304	132	436	191	85.1	276
		6	379	96.0	475	361	107	467	339	119	458	314	134	447	191	82.4	274
7		392	97.0	489	372	108	480	350	120	470	324	135	459	193	80.7	274	
8		404	97.9	502	384	109	493	362	121	483	335	136	471	197	79.9	277	
9		417	98.8	515	396	110	506	373	123	496	346	137	483	196	77.3	273	
10		429	99.7	529	409	111	520	385	124	508	355	137	492	199	76.4	275	
11		443	101	543	421	112	533	397	125	521	362	136	498	201	75.5	277	
12		456	102	557	434	113	547	409	126	535	370	135	504	199	72.8	271	
13		469	103	572	447	114	561	421	127	548	374	131	505	201	71.9	273	
14		483	104	586	460	115	575	433	129	562	378	128	505	202	70.9	273	
15		497	104	601	473	116	589	446	130	575	381	125	506	204	70.0	274	
400		4	386	104	489	367	115	482	344	129	473	318	145	463	197	90.7	288
		5	399	105	503	379	116	495	356	130	486	329	146	475	201	89.7	291
		6	411	106	517	391	117	509	368	131	499	340	147	487	201	86.9	288
	7	425	107	531	404	119	522	380	132	512	351	148	500	205	85.9	291	
	8	438	108	546	416	120	536	392	134	525	363	150	513	208	85.0	293	
	9	451	109	560	429	121	550	404	135	539	374	151	526	207	82.1	289	
	10	465	110	575	443	122	565	417	136	553	383	150	532	210	81.2	291	
	11	479	111	590	456	123	579	429	138	567	387	146	533	212	80.2	293	
	12	493	112	605	470	125	594	442	139	581	391	142	533	209	77.3	286	
	13	508	113	621	483	126	609	455	140	595	395	139	534	211	76.2	287	
	14	523	114	637	497	127	624	468	142	610	399	135	534	213	75.2	288	
	15	538	115	653	511	128	640	482	143	625	403	132	535	214	74.1	288	
	420	4	415	112	527	394	125	519	370	139	509	341	156	497	207	95.5	303
		5	429	113	542	407	126	533	382	141	523	353	158	510	209	93.4	303
		6	443	115	557	420	127	548	395	142	537	365	159	524	211	91.4	303
7		457	116	572	434	129	562	408	143	551	377	161	537	212	89.3	302	
8		471	117	588	448	130	577	421	145	565	387	161	548	213	87.3	301	
9		486	118	604	462	131	593	434	146	580	395	159	554	216	86.3	303	
10		501	119	620	476	132	608	447	148	595	402	156	558	219	85.3	304	
11		516	120	636	490	134	624	461	149	610	407	152	559	219	83.3	302	
12		531	122	652	505	135	640	475	151	625	411	148	559	218	81.1	299	
13		546	123	669	519	137	656	489	152	641	413	143	557	219	80.0	299	
14		562	124	686	534	138	672	503	154	656	417	140	557	221	78.8	300	
15		578	125	703	550	139	689	517	155	672	421	136	557	222	77.6	299	

NOTES

Cc (cooling capacity) - Pi (unit power input) - ELWT (evaporator leaving water temperature - Δt 5°C).

Data are referred to 0,0176 m²/kW evaporator fouling factor

Rated conditions are for compressors running at nominal frequency.

9 Options

EWAD-BZ

Size	ELWT (°C)	Condenser Inlet Air Temperature (°C)															
		30/35			35/40			40/45			45/50			50/55			
		Rated			Rated			Rated			Rated			Rated			
	Cc (kW)	Pi (kW)	Hc (kW)	Cc (kW)	Pi (kW)	Hc (kW)	Cc (kW)	Pi (kW)	Hc (kW)	Cc (kW)	Pi (kW)	Hc (kW)	Cc (kW)	Pi (kW)	Hc (kW)		
460	4	443	121	563	420	134	554	394	150	543	363	168	531	217	100	317	
	5	457	122	579	434	136	569	407	151	558	375	170	545	217	96.9	314	
	6	472	123	595	448	137	585	420	153	573	388	171	559	221	95.9	316	
	7	487	124	611	462	138	601	434	154	588	400	173	573	219	92.6	312	
	8	502	126	628	477	140	617	448	156	603	410	171	581	222	91.5	314	
	9	518	127	645	492	141	633	462	157	619	415	167	581	225	90.4	316	
	10	534	128	662	507	143	649	476	159	635	420	162	582	228	89.3	317	
	11	550	130	679	522	144	666	490	161	651	425	158	583	224	86.0	310	
	12	566	131	697	537	146	683	505	162	667	429	154	583	226	84.8	311	
	13	582	132	714	553	147	700	520	164	684	433	150	584	227	83.6	311	
	14	599	134	732	569	149	718	535	166	700	437	147	584	229	82.4	311	
	15	616	135	751	585	150	735	550	167	717	441	143	584	229	81.1	310	
	490	4	472	130	602	448	145	592	420	161	581	382	178	560	227	105	332
		5	488	131	619	463	146	609	434	163	597	395	179	575	226	102	328
		6	503	133	636	478	148	625	448	165	612	407	179	586	230	101	331
7		519	134	653	493	149	642	462	166	629	420	181	601	231	98.2	329	
8		536	136	671	508	151	659	477	168	645	430	179	609	235	97.1	332	
9		552	137	689	524	152	676	492	170	661	435	175	610	234	94.6	329	
10		569	138	707	540	154	694	507	171	678	438	169	607	237	93.4	330	
11		586	140	726	556	155	712	522	173	695	443	164	607	236	91.1	327	
12		603	141	744	573	157	730	538	175	713	448	160	608	238	89.9	328	
13		621	143	763	589	159	748	553	177	730	452	156	608	239	88.6	328	
14		638	144	782	606	160	766	567	177	743	456	152	608	240	87.3	327	
15		656	146	802	623	162	785	583	179	761	459	148	608	241	85.9	327	
520		4	500	139	639	474	155	629	444	173	617	401	187	588	236	110	346
		5	516	141	657	490	156	646	459	174	633	415	189	603	235	106	342
		6	533	142	675	505	158	663	474	176	650	424	187	611	239	105	344
	7	549	144	693	521	160	681	489	178	667	438	189	627	243	104	347	
	8	566	145	711	538	161	699	504	180	684	448	187	635	246	103	349	
	9	584	147	730	554	163	717	520	182	702	454	182	636	243	98.8	342	
	10	601	148	749	571	165	736	536	183	719	459	177	636	245	97.5	343	
	11	619	150	769	588	166	754	552	185	737	464	173	637	247	96.2	344	
	12	637	151	788	605	168	773	568	187	755	469	169	637	249	94.9	344	
	13	656	153	808	623	170	792	584	189	774	473	164	637	250	93.5	344	
	14	674	154	829	640	172	812	596	188	783	477	160	637	251	92.1	343	
	15	693	156	849	658	173	832	612	190	802	480	156	637	252	90.6	342	

NOTES

Cc (cooling capacity) - Pi (unit power input) - ELWT (evaporator leaving water temperature - Δt 5°C).
 Data are referred to 0,0176 m² °C/kW evaporator fouling factor
 Rated conditions are for compressors running at nominal frequency.

9 Options

EWAD-BZ
Partial Heat Recovery Ratings

Size	330	360	400	420	460	490	520
Heating Capacity (kW)	424	470	512	551	588	629	667
Water Flow (l/s)	20,47	22,47	24,45	26,32	28,09	30,03	31,86
Heat Recovery Pressure Drops (kPa)	55	65	55	62	60	65	65

Water flow and pressure drop referred to nominal condition: evaporator water in/out: 12/7°C – water heat recovery in/out 40/45°C

OPT_1-2-3-4-5-6-7_Rev.00_3

EWAD-BZ
Partial Heat Recovery Ratings

EWAD-BZSS/SL EWAD-BZXS/XL/XR	Evaporator Leaving Temperature 7°C - Δt 5°C	Condenser Inlet Air 35°C	1Partial Heat Recovery Leaving Water Temperature (°C)			Partial Heat Rrecovery LWT 45°C	
			45 (Δt=5°C) Hc (kW)	50 (Δt=5°C) Hc (kW)	55 (Δt=5°C) Hc (kW)	Water Flow l/s	Pressure Drops kPa
330			86	69	52	4.11	40
360			95	76	57	4.54	50
400			104	83	62	4.97	39
420			112	90	67	5.35	45
460			120	96	72	5.73	52
490			128	102	77	6.12	60
520			136	109	82	6.50	43

OPT_1-2-3-4-5-6-7_Rev.00_4

9 Options

EWAD-BZ

To determine the pressure drop for different versions or at different working condition, please refer to the following formula:

$$PD_2 \text{ (kPa)} = PD_1 \text{ (kPa)} \times \left(\frac{Q_2 \text{ (l/s)}}{Q_1 \text{ (l/s)}} \right)^{1.80}$$

where:

- PD_2 Pressure drop to be determinate (kPa)
- PD_1 Pressure drop at nominal condition (kPa)
- Q_2 water flow at new working condition (l/s)
- Q_1 water flow at nominal condition (l/s)

How to use the formula: Example

The unit EWAD330BZSS has been selected for working at the following conditions:

- Partial heat recovery leaving water temperature 50/55°C
- The heating capacity at these working conditions is: 52 kW
- The water flow at these working conditions is: 2.48 l/s

The unit EWAD330BZSS at nominal working conditions has the following data:

- Partial heat recovery leaving water temperature 40/45°C
- condenser air inlet: 35°C
- The heating capacity at these working conditions is: 86 kW
- The water flow at these working conditions is: 4.11 l/s
- The pressure drop at these working conditions is: 40 kPa

The pressure drop at the selected working condition will be:

$$PD_2 \text{ (kPa)} = 40 \text{ (kPa)} \times \left(\frac{2.48 \text{ (l/s)}}{4.11 \text{ (l/s)}} \right)^{1.80}$$

$$PD_2 \text{ (kPa)} = 16 \text{ (kPa)}$$

OPT_1-2-3-4-5-6-7_Rev.00_5

9 Options

EWAD-BZ

Single Pump (2 poles) - Low Available external static pressure

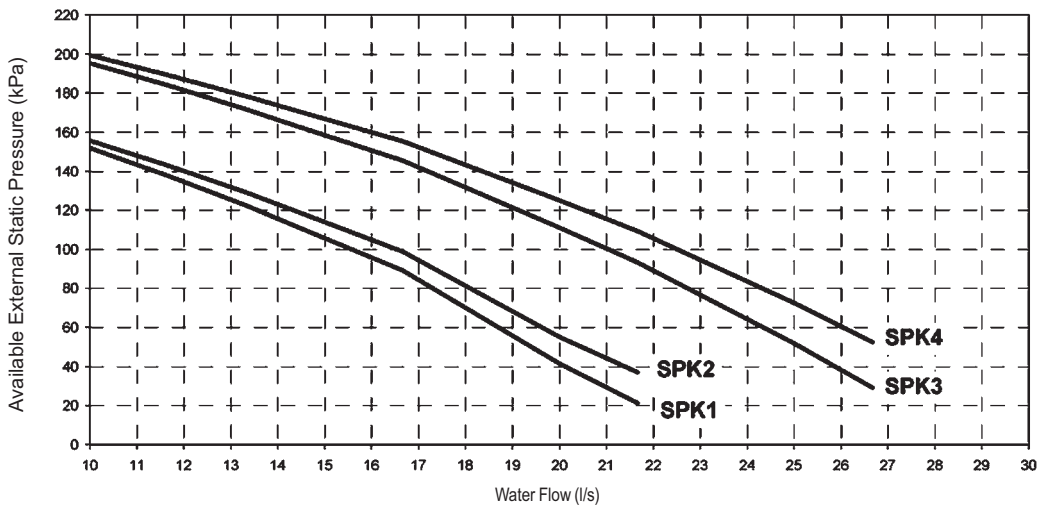

NOTE

When using mixture of water and glycol please contact the factory as above specification can change

Pump Kit	SPK1	SPK2	SPK3	SPK4
Size EWAD-BZSS/SL and Size EWAD-BZXS/XL/XR	330	360	400	420
			460	490
				520

Single Pump (2 poles) - High Available external static pressure

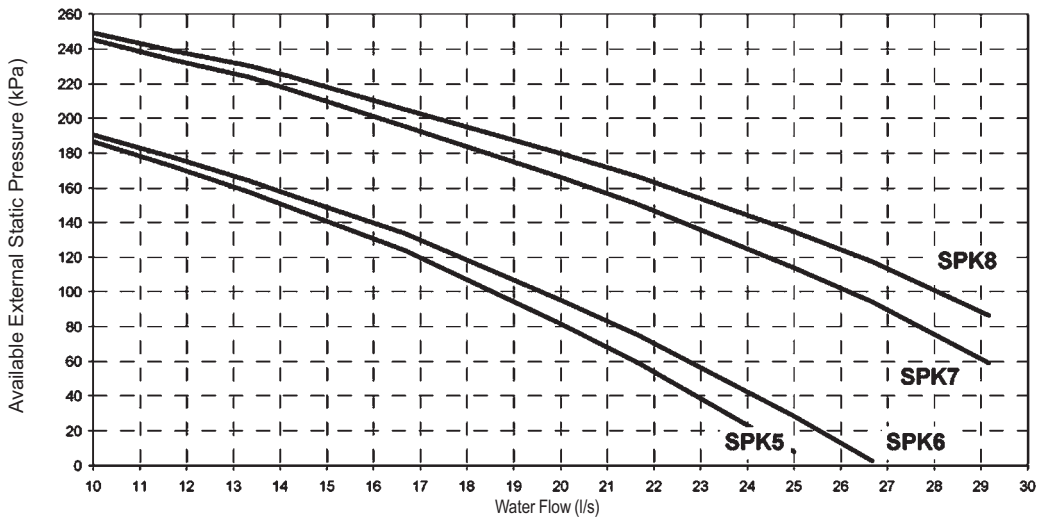

NOTE

When using mixture of water and glycol please contact the factory as above specification can change

Pump Kit	SPK5	SPK6	SPK7	SPK8
Size EWAD-BZSS/SL and Size EWAD-BZXS/XL/XR	330	360	400	420
			460	490
				520

9 Options

EWAD-BZ

Twin Pump (2 poles) - Low Available external static pressure

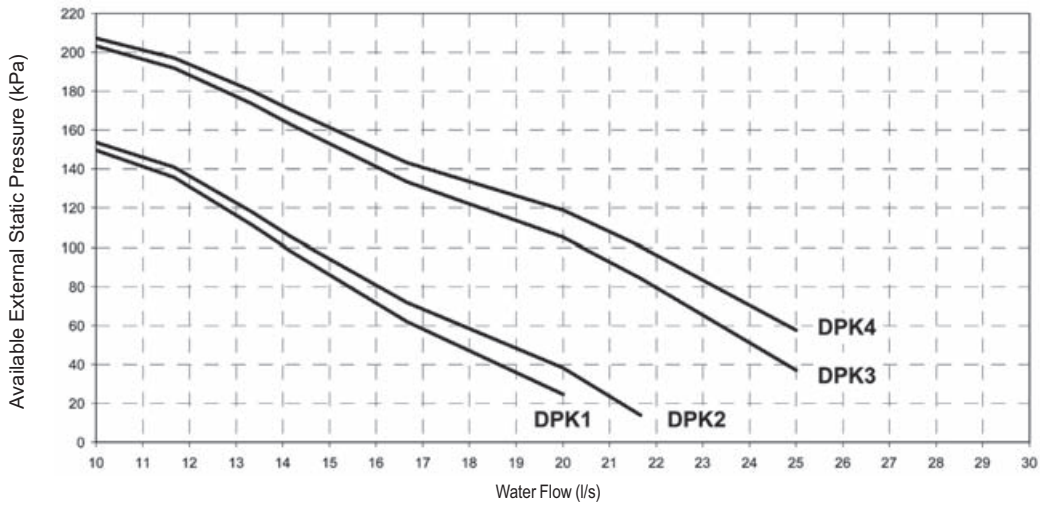

NOTE

when using mixture of water and glycol please contact the factory as above specification can change

Pump Kit	DPK5	DPK6	DPK7	DPK8			
Size EWAD-BZSS/SL and Size EWAD-BZXS/XL/XR	330	360	400	420	460	490	520

Twin Pump (2 poles) - High Available external static pressure

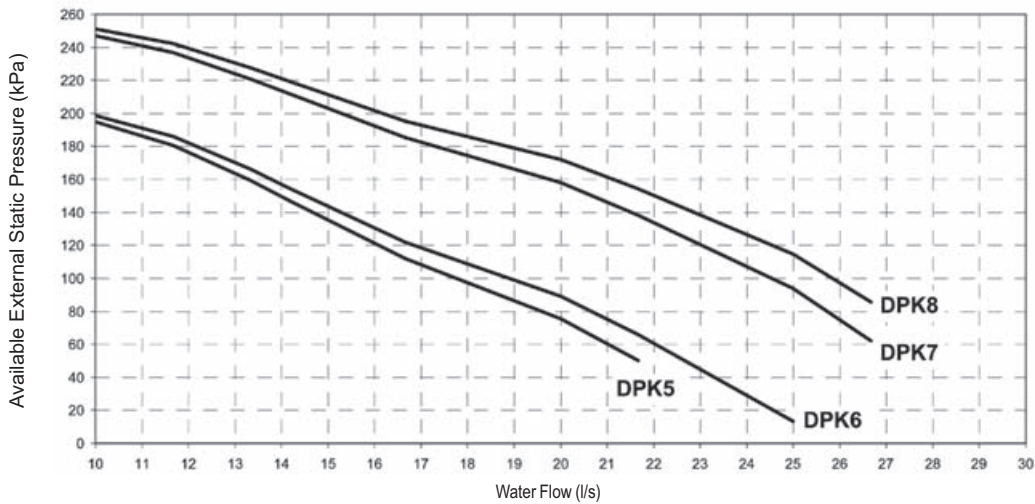

NOTE

when using mixture of water and glycol please contact the factory as above specification can change

Pump Kit	DPK5	DPK6	DPK7	DPK8			
Size EWAD-BZSS/SL and Size EWAD-BZXS/XL/XR	330	360	400	420	460	490	520

9 Options

EWAD-BZ

		Pump Motor Power (kW)	Pump Motor Current (A)	Power supply (V-ph-Hz)	PN	Motor Protection	Insulation (Class)	Working Temp. (°C)
Single Pump	SPK 1	4,0	8,0	400V-3ph-50hz	10	IP54	Class F	-10 ÷ 130
	SPK 2	4,0	8,0	400V-3ph-50hz	10	IP54	Class F	-10 ÷ 130
	SPK 3	5,5	10,1	400V-3ph-50hz	10	IP54	Class F	-10 ÷ 130
	SPK 4	5,5	10,1	400V-3ph-50hz	10	IP54	Class F	-10 ÷ 130
	SPK 5	5,5	10,1	400V-3ph-50hz	10	IP54	Class F	-10 ÷ 130
	SPK 6	5,5	10,1	400V-3ph-50hz	10	IP54	Class F	-10 ÷ 130
	SPK 7	7,5	13,7	400V-3ph-50hz	10	IP54	Class F	-10 ÷ 130
	SPK 8	7,5	13,7	400V-3ph-50hz	10	IP54	Class F	-10 ÷ 130
Double Pump	DPK 1	4,0	8,0	400V-3ph-50hz	10	IP54	Class F	-10 ÷ 130
	DPK 2	4,0	8,0	400V-3ph-50hz	10	IP54	Class F	-10 ÷ 130
	DPK 3	5,5	10,1	400V-3ph-50hz	10	IP54	Class F	-10 ÷ 130
	DPK 4	5,5	10,1	400V-3ph-50hz	10	IP54	Class F	-10 ÷ 130
	DPK 5	5,5	10,1	400V-3ph-50hz	10	IP54	Class F	-10 ÷ 130
	DPK 6	5,5	10,1	400V-3ph-50hz	10	IP54	Class F	-10 ÷ 130
	DPK 7	7,5	13,7	400V-3ph-50hz	10	IP54	Class F	-10 ÷ 130
	DPK 8	7,5	13,7	400V-3ph-50hz	10	IP54	Class F	-10 ÷ 130

NOTE

when using mixture of water and glycol please contact the factory as above specification can change

10 Dimensions

EWAD-BZ

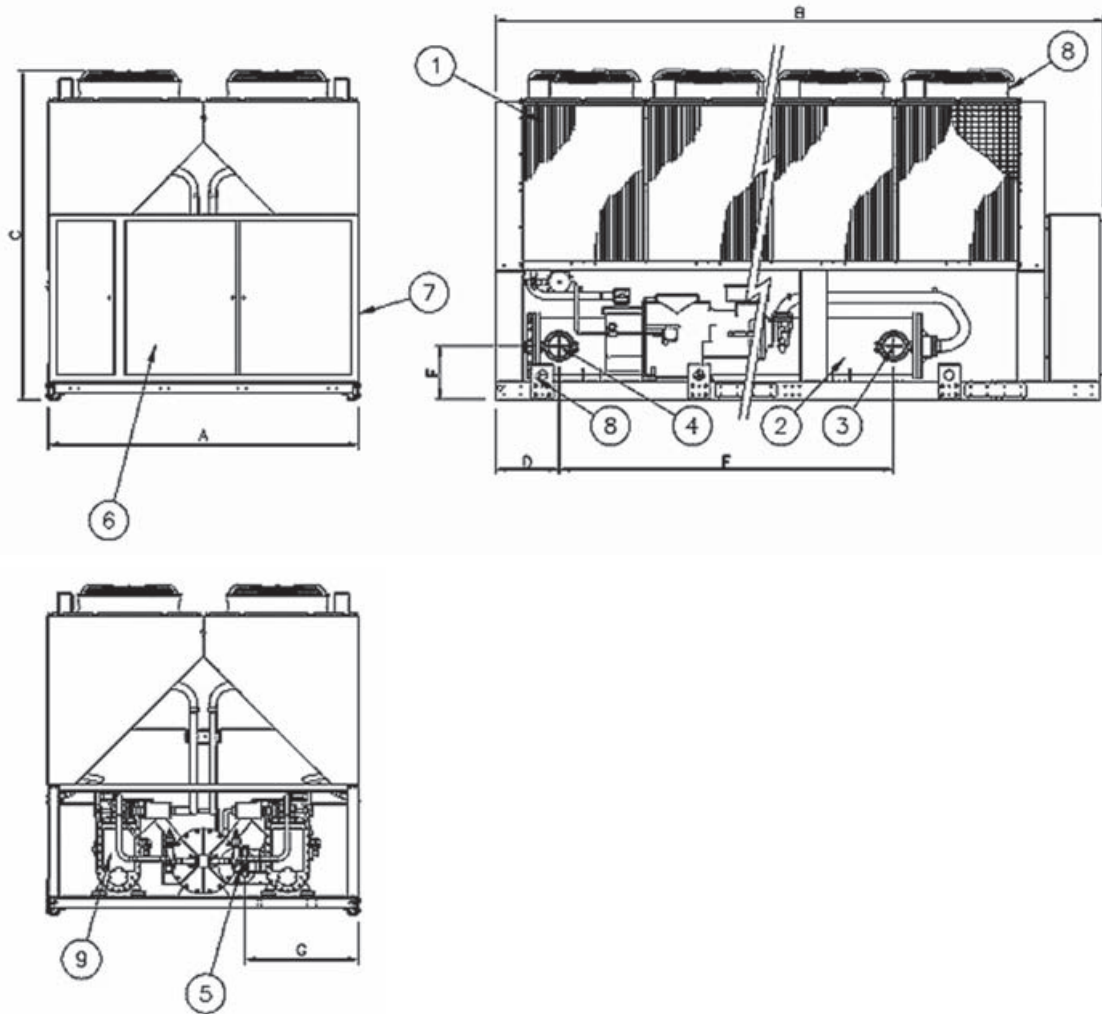

EWAD-BZ	Dimensions							
Size	A	B	C	D	E	F	G	Fans
330	2224	4352	2355	455	2412	379	810	Nr 8
360	2224	4352	2355	455	2412	379	810	Nr 8
400	2224	5252	2355	455	5412	379	810	Nr 10
420	2224	5252	2355	455	5412	379	810	Nr 10
460	2224	6152	2355	455	2412	379	810	Nr 12
490	2224	6152	2355	455	2412	379	810	Nr 12
520	2224	6152	2355	455	2412	379	810	Nr 12

NOTES

- 1 Condenser Coil
- 2 Water heat exchanger (evaporator)
- 3 Evaporator water inlet
- 4 Evaporator water outlet
- 5 Victaulic connection
- 6 Operating and control panel
- 7 Slot for power and control connection
- 8 Fan
- 9 Compressor

11 Installation notes

Warning

Installation and maintenance of the unit must be performed only by qualified personnel who have knowledge with local codes and regulations, and experience with this type of equipment. Must be avoided the unit installation in places that could be considered dangerous for all the maintenance operations.

Handling

Care should be taken to avoid rough handling or shock due to dropping the unit. Do not push or pull the unit from anything other than the base frame. Never allow the unit to fall during unloading or moving as this may result in serious damage. To lift the unit, rings are provided in the base frame of the unit. Spreader bar and cables should be arranged to prevent damage to the condenser coil or unit cabinet.

Location

The units are produced for outside installation on roofs, floors or below ground level on condition that the area is free from obstacles for the passage of the condenser air. The unit should be positioned on solid foundations and perfectly level; in the case of installation on roofs or floors, it may be advisable to arrange the use of suitable weight distribution beams. When the units are installed on the ground, a concrete base at least 250 mm wider and longer than the unit's footprint should be laid. Furthermore, this base should withstand the unit weight mentioned in the technical data table.

Space requirements

The units are air-cooled, then it is important to respect the minimum distances which guarantee the best ventilation of the condenser coils. Limitations of space reducing the air flow could cause significant reductions in cooling capacity and an increase in electricity consumption.

To determinate unit placement, careful consideration must be given to assure a sufficient air flow across the condenser heat transfer surface. Two conditions must be avoided to achieve the best performance: warm air recirculation and coil starvation.

Both these conditions cause an increase of condensing pressures that result in reductions in unit efficiency and capacity.

Moreover the unique microprocessor has the ability to calculate the operating environment of the air cooled chiller and the capacity to optimize its performance staying on-line during abnormal conditions.

Each side of the unit must be accessible after installation for periodic service. Fig.1 shows you minimum recommended clearance requirements.

Vertical condenser air discharge must be unobstructed because the unit would have its capacity and efficiency significantly reduced.

If the units are positioned in places surrounded by walls or obstacles of the same height as the units, the units should be at least 2500 mm from obstacles (fig.3). In the event the obstacles are higher than the units, the units should be at least 3000 mm from the obstacle (fig.2). Units installed closer than the minimum recommended distance to a wall or other vertical riser may experience a combination of coil starvation and warm air recirculation, thus causing reduction in unit capacity and efficiency reductions. The microprocessor control is proactive in response "of design condition". In the case of single or compounded influences restricting airflow to the unit, the microprocessor will act to keep the compressor(s) running (at reduced capacity) rather than allowing a shut-off on high discharge pressure.

When two or more units are positioned side by side it is recommended that the condenser coils are at least 3600 mm distance from one another (fig.4); strong wind could be the cause of air warm recirculation.

For other installation solutions, consult our technicians.

11 Installation notes

The above recommended information are representative of general installation. A specific evaluation should be done by contractor depending on the case.

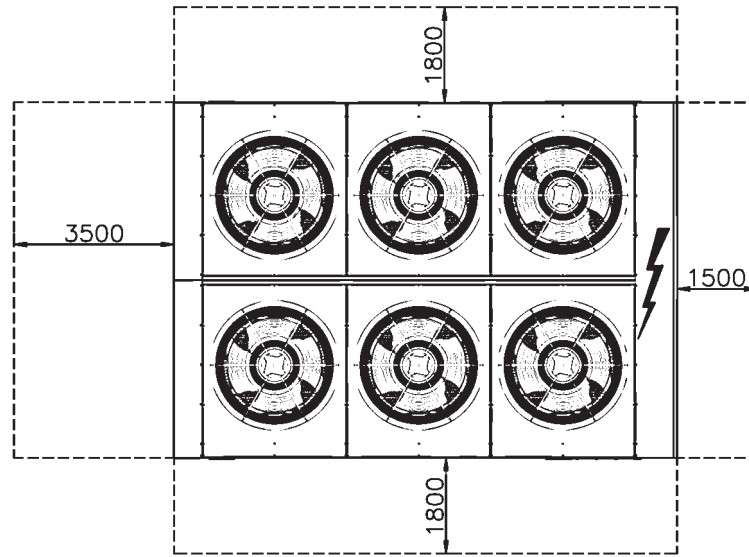

Fig. 1 - Minimum recommended installation clearances

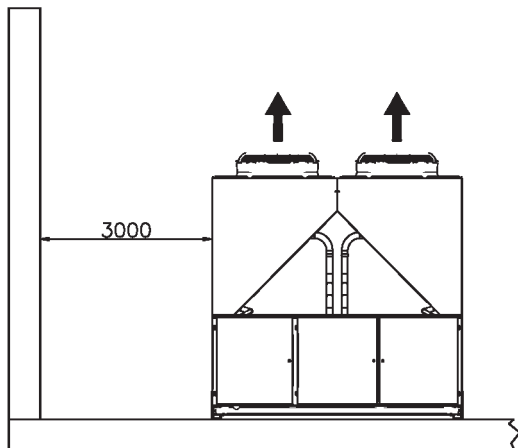

Fig. 2

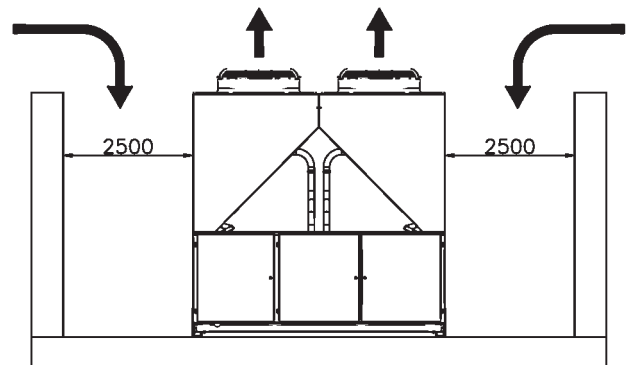

Fig. 3

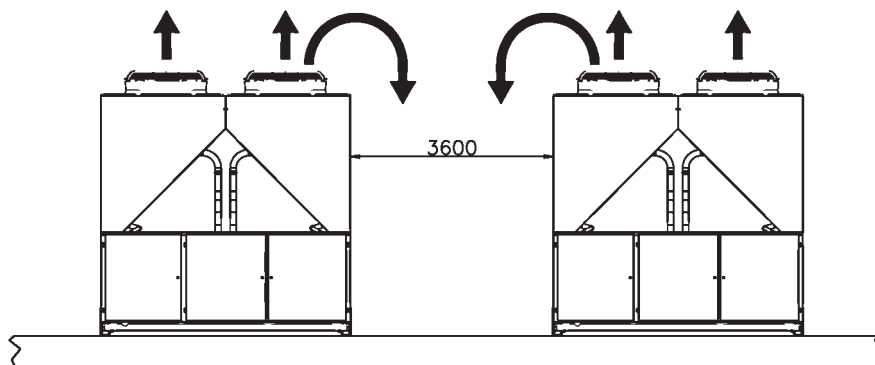

Fig. 4

Minimum clearance requirements for machine maintenance

11 Installation notes

Acoustic protection

When noise level must meet special requirements, it is necessary to pay the maximum attention to ensure the perfect insulation of the unit from the support base by applying appropriate vibration-dampening devices on the unit, on the water pipes and on the electrical connections.

Storage

The environment conditions have to be in the following limits:

Minimum ambient temperature:	-20°C
Maximum ambient temperature:	+57°C
Maximum R.H.:	95% not condensing

INN_1-2-3_Rev.00_3

12 Specification

Technical Specification for Air Cooled Screw Chiller

GENERAL

The air to Water Heat Pump will be designed and manufactured in accordance with following European directives:

Rating of chillers	EN 12055
Construction of pressure vessel	97/23/EC (PED)
Machinery Directive	98/37/EC as modified
Low Voltage	2006/95/EC
Electromagnetic Compatibility	2004/108/EC
Electrical & Safety codes	EN 60204-1 / EN 60335-2-40
Manufacturing Quality Stds	UNI – EN ISO 9001:2000
Rating of chillers	EN 12055

The unit will be tested at full load in the factory at the nominal working conditions and water temperatures. Before shipment a full test will be held to avoid any losses.

Chiller will be delivered to the job site completely assembled and charged with right refrigerant and oil quantity. Comply with the manufacturer instructions for rigging and handling equipment.

The unit will be able to start up and operate as standard at full load and outside air temperature from °C to °C with an evaporator leaving fluid temperature between °C and 15 °C

All unit's published performances have to be certified by Eurovent.

REFRIGERANT

Only HFC 134a will be accepted.

PERFORMANCE

- ✓ Number of air cooled screw chiller:
- ✓ Cooling capacity for single air cooled screw chiller: kW
- ✓ Power input for single air cooled screw chiller in cooling mode: kW
- ✓ Shell & tube heat exchanger entering water temperature in cooling mode: °C
- ✓ Shell & tube heat exchanger leaving water temperature in cooling mode: °C
- ✓ Shell & tube heat exchanger water flow: l/s
- ✓ Nominal outside working ambient temperature in cooling mode: °C

- ✓ The unit should work with electricity in range 400 V ±10%, 3ph, 50Hz without neutral and shall only have one power connection point. The control circuit voltage shall be 24 V maximum, supplied by a factory-installed transformer.

UNIT DESCRIPTION

The unit shall include as standard not less than: two independent refrigerant circuits, semi-hermetic rotary single screw compressors, air-cooled variable electrical frequency driver for each compressor (VFD), electronic expansion device (EEXV), refrigerant direct expansion shell & tube heat exchanger, air-cooled condenser section, R134a refrigerant, lubrication system, motor starting components, suction line shut-off valve, discharge line shut-off valve, control system and all components necessary for safe and stable unit operation.

The unit will be factory assembled on a robust base-frame made of zinc coated steel, protected by an epoxy paint.

12 Specification

NOISE LEVEL AND VIBRATIONS

Sound pressure level at 1 meter distance in free field, semispheric conditions, shall not exceeddB(A). The sound pressure levels must be rated in accordance to ISO 3744.

Other types of rating unacceptable. Vibration level should not exceed 2 mm/s.

DIMENSIONS

Unit dimensions shall not exceed following indications:

- ✓ unit length mm,
- ✓ unit width mm,
- ✓ unit height mm.

HEAT PUMP COMPONENTS

Compressors

- ✓ Semi-hermetic, single-screw type with one main helical rotor meshing with gaterotor. The gaterotor will be constructed of a carbon impregnated engineered composite material. The gaterotor supports will be constructed of cast iron.
- ✓ The oil injection shall be used in order to get high EER (Energy Efficiency Ratio) also at high condensing pressure and low sound pressure levels in each load condition.
- ✓ Refrigerant system differential pressure shall provide oil flow through service replaceable, 0.5 micron, full flow, cartridge type oil filter internal to compressor.
- ✓ Refrigerant system differential pressure shall provide oil injection on all moving compressor parts to correctly lubricate them. Electrical oil pump lubricating system is not acceptable.
- ✓ The compressor's oil cooling must be realized, when necessary, by refrigerant liquid injection. External dedicated heat exchanger and additional piping to carry the oil from the compressor to heat exchanger and viceversa will be not accepted.
- ✓ The compressor shall be provided with an integrated, high efficiency, cyclonic type oil separator and with built-in oil filter, cartridge type.
- ✓ The compressor shall be direct electrical driven, without gear transmission between the screw and the electrical motor.
- ✓ The compressor casing shall be provided with ports to realize economized refrigerant cycles.
- ✓ Shall be present two thermal protection realized by a thermistor for high temperature protection: one temperature sensor to protect electrical motor and another sensor to protect unit and lubricating oil from high discharge gas temperature.
- ✓ The compressor shall be equipped with an electric oil-crankcase heater.
- ✓ Compressor shall be fully field serviceable. Compressor that must be removed and returned to the factory for service shall be unacceptable.

Cooling capacity control system

- ✓ Each unit will have a microprocessor for the control of compressor inverter position and the instantaneous RPM value of the motor.
- ✓ The unit capacity control shall be infinitely modulating, from 100% down to 27% for each compressor (from 100% down to 13.5% of full load for units with 2 compressors).
- ✓ Step unloading unacceptable because of evaporator leaving water temperature fluctuation and low unit efficiency at partial load.
- ✓ The system shall stage the unit based on the leaving evaporator water temperature that shall be controlled by a PID (Proportional Integral Derivative) loop.
- ✓ Unit control logic shall to manage frequency level of the compressor electric motor to exactly match plant load request in order to keep constant the set point for delivered chilled or hot water temperature. In this operating condition unit control logic shall modulate electrical frequency level in a range lower and upper the nominal electrical network value fixed at 50 Hz.

SPC_1-2-3-4-5_Rev.00_2

12 Specification

- ✓ The microprocessor unit control shall detect conditions that approach protective limits and take self-corrective action prior to an alarm occurring. The system shall automatically reduce chiller capacity when any of the following parameters are outside their normal operating range:
 - High condenser pressure
 - Low evaporation refrigerant temperature
 - High compressor motor amps

Unit-Mounted Variable Frequency Driver (VFD) and Electrical Requirement

- ✓ All interconnecting wiring between the VFD and the chiller shall be factory-installed. Customer electrical connection for compressor motor power shall be limited to main power leads to the single point power connection located into electrical panel.
- ✓ The VFD shall be air cooled type. Water cooled design or refrigerant cooled design are not acceptable.
- ✓ The VFD full load efficiency shall meet or exceed 97% at 100% VFD rated capacity.
- ✓ Base motor frequency shall permit motor to be utilized at nameplate voltage. Adjustable frequency range, monitored by unit's microprocessor control, shall permit a stable unit capacity control down to 13.5% without hot-gas bypass.
- ✓ Starting current for the compressor shall not exceed nominal compressor load amps.
- ✓ Unit power factor shall be not less than 0.95 on entire unit capacity range, from 100% down to 13.5%.

Evaporator

- ✓ The units shall be supplied with shell and tubes counter-flow heat exchanger with single refrigerant pass. It will be refrigerant direct expansion type with refrigerant inside the tubes and water outside (shell side). It will include carbon steel tube sheets, with straight copper tubes internally wound for higher efficiencies, expanded on the tube plates.
- ✓ The external shell shall be linked with an electrical heater to prevent freezing down to -28°C ambient temperature, commanded by a thermostat and shall be insulated with flexible, closed cell polyurethane insulation material (10-mm thick).
- ✓ The evaporator will have 2 circuits, one for each compressor and shall be single refrigerant pass.
- ✓ The water connections shall be VICTAULIC type connections as standard to ensure quick mechanical disconnection between the unit and the hydronic network.
- ✓ Evaporator is manufactured in accordance to PED approval.

Condenser coil

- ✓ The condenser coils are constructed with internally finned seamless copper tubes having a "W" configuration and arranged in a staggered row pattern and mechanically expanded into lanced and rippled aluminium fins with full fin collars for higher efficiencies. The space between the fins are given by a collar that will increase the surface area in connection with the tubes, protecting them from ambient corrosion.
- ✓ The coils will have an integral subcooler circuit that provides sufficient subcooling to effectively eliminate the possibility of liquid flashing and increase the unit's efficiency of 5-7% without increasing in power absorption.
- ✓ The condenser coil shall be leak-tested and submitted to a pressure test with dry air.

Condenser fans

- ✓ The fans used in conjunction with the condenser coils, shall be propeller type with high efficiency design blades to maximize performances and lower noise. The material of the blades is glass reinforced resin and each fan is protected by a guard.
- ✓ The air discharge shall be vertical and each fan must be coupled to the electrical motor. Fan motor will be thermally protected (as standard) by internal thermal motor and protected by circuit breaker installed inside the electrical panel as a standard. The motor will be IP54.

12 Specification

Refrigerant circuit

- ✓ The unit must have refrigerant circuits completely independent of each other with one compressor and one variable electrical frequency driver per circuit (VFD).
- ✓ Each circuit shall include as standard: electronic expansion device piloted by unit's microprocessor control, compressor discharge shut-off valve, suction line shut-off valve, liquid line shut-off valve with charging connection, replaceable core filter-drier, sight glass with moisture indicator and insulated suction line.

Condensation control

- ✓ The units will be provided with an automatic control for condensing pressure which ensures the working at low external temperatures down to -10 °C, thanks the Inverter on the condenser fans, to maintain condensing pressure.
- ✓ Automatic compressor unloading when abnormal high condensing pressure is detected to prevent the shutdown of the refrigerant circuit (shutdown of the unit) due to a high-pressure fault.

Low Noise unit options (on request)

- ✓ The unit compressors shall be connected with unit's metal baseframe by rubber antivibration supports to prevent the transmission of vibrations to all metal unit structure and so to control the unit noise.
- ✓ The suction lines shall be provided with mufflers to eliminate vibration and so to reduce the noise unit emission.
- ✓ The chiller shall be provided with an acoustically compressor enclosure. This enclosure shall be realized with a light, corrosion resisting aluminium structure and metal panels. The compressors sound-proof enclosure shall be internally fitted with flexible, multi layer, high density materials. The middle layer is 3 mm, very high density and high efficiency noise reduction material. The enclosure shall be carefully assembled to avoid decreasing of its noise reduction power.
- ✓ The chiller shall be provided with very low speed condenser fans and with an improved condenser section.

SPC_1-2-3-4-5_Rev.00_4

12 Specification

Control panel

- ✓ Field power connection, control interlock terminals, and unit control system should be centrally located in an electric panel (IP 54). Power and starting controls should be separate from safety and operating controls in different compartments of the same panel.
- ✓ Starting will be star/delta type.
- ✓ Power and starting controls should include fuses and contactors for each compressor winding and fan motors. Operating and safety controls should include energy saving control; emergency stop switch; overload protection for compressor motor; high and low pressure cut-out switch (for each refrigerant circuit); anti-freeze thermostat; cut-out switch for each compressor.
- ✓ All of the information regarding the unit will be reported on a display and with the internal built-in calendar and clock that will switch the unit ON/OFF during day time all year long.
- ✓ The following features and functions shall be included:
 - resetting chilled water temperature by controlling the return water temperature or by a remote 4-20 mA DC signal or by controlling the external ambient temperature;
 - soft load function to prevent the system from operating at full load during the chilled fluid pulldown period;
 - password protection of critical parameters of control;
 - start-to-start and stop-to-star timers to provide minimum compressor off-time with maximum motor protection;
 - communication capability with a PC or remote monitoring;
 - discharge pressure control through intelligent cycling of condenser fans;
 - lead-lag selection by manual or automatically by circuit run hours;
 - double set point for brine unit version;
 - scheduling via internal time clock to allow programming of a yearly start-stop schedule accommodating weekends and holidays.

Optional High Level Communications Interface

The controller as a minimum shall be capable of providing the data shown in the above list and document entitled McQuay-comms, using the following options:

- Option A RS485 Serial card
- Option B RS232 Serial card
- Option C LonWorks interface to FTT10A Transceiver
- Option D Bacnet Compatible