

Chillers

Air-cooled R-134a Heat Pump Inverter

- » Inverter technology
- » Wide capacity range
(250 kW - 580 kW)
- » Single screw compressor
- » Two sound versions
- » Extended operation range
- » Alternative to gas boilers



www.daikin.eu

EWYD-BZ
250~580 kW



Daikin Europe N.V.

About Daikin

Daikin has a worldwide reputation based on over 80 years' experience in the successful manufacture of high quality air conditioning equipment for industrial, commercial and residential use. Daikin's much envied quality quite simply stems from the close attention paid to design, production and testing as well as aftersales support. To this end, every component is carefully selected and rigorously tested to verify its contribution to product quality and reliability.

The Heat Pump Inverter EWYD-BZ units - Ideal solutions for comfort applications

With the introduction of the extended Heat Pump Inverter series Daikin offers an extensive inverter range (cooling capacity from 250kW up to 580kW), providing ideal solutions for comfort applications as in office buildings, shop complexes and hotels.

The new EWYD-BZ range, composed of 13 capacity sizes, incorporates inverter-driven single screw compressors which make the units suitable for use in extreme low ambient conditions.

During the heating season, as the outside temperature decreases, the thermal load requirement of the building increases and the heating capacity of a conventional heat pump will actually decrease. Therefore, an additional boiler (fossil-fuel fired or electrical) might need to be integrated with the heat pump if the temperature is dropping.

On the other hand, Daikin's Heat Pump Inverter series can fully match the building's thermal load, even at ambient temperatures down to -12°C. The inverter boosts the compressor to follow exactly the required thermal load, resulting in considerable energy and cost savings compared to a traditional system of a heat pump with integrated boiler.



Table of Contents

THE NEW HEAT PUMP INVERTER CHILLER FEATURES	4
TECHNICAL DATA	6
1 Features and advantages	6
2 General characteristics	8
3 Nomenclature	12
4 Technical & electrical specifications	13
5 Sound Levels	17
- Standard noise	18
- Low noise	19
6 Operating limits	20
7 Standard rating	27
- Cooling mode	27
- Heating mode	43
8 Evaporator pressure drop	53
9 Options	54
10 Dimensional drawing & center of gravity	61
11 Installation	62
12 Specification (for tender)	64



The new heat pump inverter chiller features

Inverter regulation

The incorporation of inverter control on the compressor offers the Heat Pump Inverter the following benefits:

- no loss of heating capacity in colder temperatures (even in ambient conditions down to -12°C) because the inverter boosts the screw compressor with a frequency increase to follow exactly the required thermal load
- lower starting current - each time the compressor is turned on - compared to standard fixed speed models or units provided with traditional softstarter options
- power factor will always be greater than 0.95, in all functioning conditions
- allowing to regulate with maximum precision the compressor capacity, resulting in:
 - higher energy efficiency in partial load conditions
 - less frequent start/stop cycles
 - reduction of life-cycle costs and increase of reliability

Guaranteeing maximum comfort

Being able to provide the required capacity at all times, units with inverter regulation ensure constant outlet water temperature control; minimal deviations compared to the set point. Therefore, together with the efficiency of the elements of the system, it will be possible to guarantee the maximum comfort in every served area of the building.

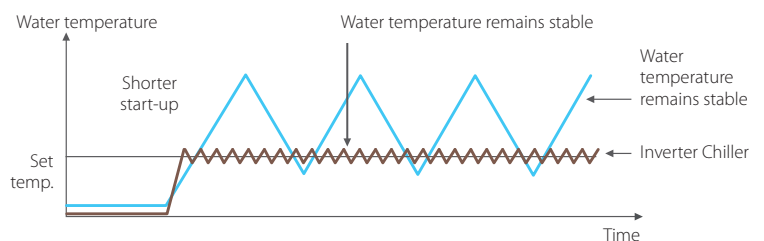

FLEXIBLE APPLICATION & LARGE OPERATION RANGE

The new Heat Pump inverter range is composed of 13 capacity sizes, with heating capacities ranging from 270 to 615 kW and cooling capacities from 250 to 580 kW, available in both standard and low noise version, and supported by an extensive range of Daikin fan coil units.

Sound

The new EWYD-BZ series can be offered as low sound version, including lower speed condenser fans, suction and discharge muffler, and highly absorbent sound proof cabinets around the compressor. Sound reduction towards standard units is +/- 7dBA.

PARTIAL HEAT RECOVERY

By energetically recovering useful heat from the cooling cycle (that would otherwise be rejected to the outside), the unit can maximize its efficiency and offer savings in hot water production. To benefit from this, Daikin offers the full heat pump inverter range with partial heat recovery, to further increase the application flexibility and extend possibilities in the hotel and leisure industry as well as the industrial and process sectors.

Quick comfort conditions

The ability to vary the output power in direct relation to the cooling requirements of the system, allow the possibility to achieve building comfort conditions much faster at start-up.

Low starting current

No current spikes at start-up. The starting current is always lower than current absorbed in the maximum operating conditions (FLA).

Power factor always > 0.95

EWYD-BZ can operate always > 0.95 power factor, which can allow building owners avoid power factor penalties and decrease electrical losses in cable and transformers.

Redundancy

EWYD-BZ has two or three truly independent refrigerant circuits in every size, in order to assure maximum safety for any maintenance, whether planned or not.

Sound

The new EWYD-BZ series can be offered as low sound version, including lower speed condenser fans, suction and discharge muffler, and highly absorbent sound proof cabinets around the compressor. Sound reduction towards standard units is +/- 7dBA.

PARTIAL HEAT RECOVERY

By energetically recovering useful heat from the cooling cycle (that would otherwise be rejected to the outside), the unit can maximize its efficiency and offer savings in hot water production. To benefit from this, Daikin offers the full heat pump inverter range with partial heat recovery, to further increase the application flexibility and extend possibilities in the hotel and leisure industry as well as the industrial and process sectors.

Quick comfort conditions

The ability to vary the output power in direct relation to the cooling requirements of the system, allow the possibility to achieve building comfort conditions much faster at start-up.

Low starting current

No current spikes at start-up. The starting current is always lower than current absorbed in the maximum operating conditions (FLA).

Power factor always > 0.95

EWYD-BZ can operate always > 0.95 power factor, which can allow building owners avoid power factor penalties and decrease electrical losses in cable and transformers.

Redundancy

EWYD-BZ has two or three truly independent refrigerant circuits in every size, in order to assure maximum safety for any maintenance, whether planned or not.

1 Features and advantages

Features and advantages

Infinitely capacity control

Cooling capacity control is infinitely variable by means of a Inverter driven screw compressor controlled by microprocessor system. Each unit has infinitely variable capacity control from 100% down to 13,5% (two compressors units) and down to 7% (three compressors). This modulation allows the compressor capacity to exactly match the building cooling load without any leaving evaporator water temperature fluctuation. This chilled water temperature fluctuation is avoided only with a stepless control.

With a compressor load step control in fact, the compressor capacity, at partial loads, will be too high or too low compared to the building cooling load. The result is an increase in chiller energy costs, particularly at the part-load conditions at which the chiller operates most of the time.

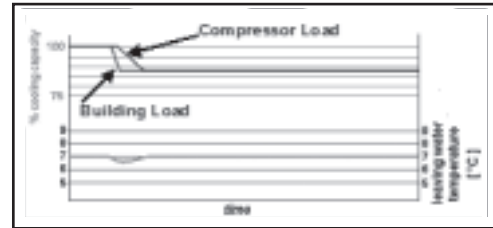

ELWT fluctuation with steps capacity control (4 steps)

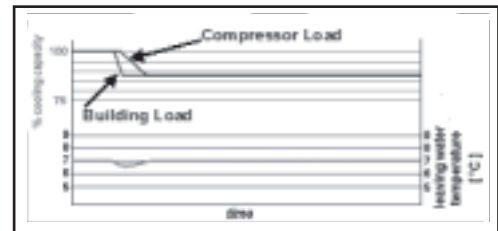

Units with stepless regulation offer benefits that the units with step regulation are unable to match. The ability to follow the system energy demand at any time and the possibility to provide steady outlet water temperature without deviations from the set-point, are the two points that allow you to understand how the optimum operating conditions of a system can be met only through the use of a unit with step-less regulation.

1 Features and advantages

Code requirements – Safety and observant of laws/directives

All EWYD~BZ- units are designed and manufactured in accordance with applicable selections of the following:

Rating of chillers	EN 12055
Construction of pressure vessel	97/23/EC (PED)
Machinery Directive	98/37/EC as modified
Low Voltage	2006/95/EC
Electromagnetic Compatibility	2004/108/EC
Electrical & Safety codes	EN 60204–1 / EN 60335-2-40
Manufacturing Quality Stds	UNI – EN ISO 9001:2000

Certifications

All units manufactured are CE marked, complying with European directives in force, concerning manufacturing and safety. On request units can be produced complying with laws in force in non European countries (ASME, GOST, etc.), and with other applications, such as naval (RINA, etc.).

Versions

EWYD~BZ is available in the following versions:

S: Standard Efficiency

13 sizes to cover a range from 254 up to 583 kW (Cooling Capacity) and from 270 up to 615 kW (Heating Capacity), with an EER up to 2.87, an ESEER up to 4.29 and a COP up to 3.04.

The EER (Energy Efficiency Ratio) is the ratio of the Cooling Capacity to the Power Input of the unit. The Power Input includes: the power input for operation of the compressor, the power input of all control and safety devices, the power input for fans.

The COP (Coefficient of Performance) is the ratio of the heating capacity to the power input of the unit.

The ESEER (European Seasonal Energy Efficiency Ratio) is a weighed formula enabling to take into account the variation of EER with the load rate and the variation of air inlet condenser temperature.

$$ESEER = A \times EER_{100\%} + B \times EER_{75\%} + C \times EER_{50\%} + D \times EER_{25\%}$$

	A	B	C	D
Coefficient	0.03 (3%)	0.33 (33%)	0.41 (41%)	0.23 (23%)
Air inlet condenser temperature	35°C	30°C	25°C	20°C

Noise Configuration

EWYD~BZ is available in two different noise level configurations:

S: Standard Noise

Condenser fan rotating at 920 rpm, rubber antivibration on compressor

L: Low Noise

Condenser fan rotating at 715 rpm (920 rpm in heating mode), rubber antivibration on compressor, compressor sound enclosure.

2 General characteristics

General characteristics

Cabinet and structure

The cabinet is made of galvanized steel sheet and painted to provide a high resistance to corrosion. Colour Ivory White (Munsell code 5Y7.5/1) (\pm RAL7044). The base frame has eye-hook for lifting the unit with ropes for an easy installation. The weight is uniformly distributed along the profiles of the base and this facilitates the arrangement of the unit.

Screw compressors with integrated oil separator

The compressors are semi-hermetic, single-screw type with gate-rotor (made of carbon impregnated engineered composite material). Each compressor has one inverter managed by the unit microprocessor for infinitely modulating the capacity. An integrated high efficiency oil separator maximises the oil separation.

Start is inverter type.

Ecological HFC 134a refrigerant

The compressors have been designed to operate with R-134a, ecological refrigerant with zero ODP (Ozone Depletion Potential) and very low GWP (Global Warming Potential) that means low TEWI (Total Equivalent Warming Impact).

Evaporator

The units are equipped with a Direct Expansion shell&tube evaporator with copper tubes rolled into steel tubesheets. The evaporators are single-pass on both the refrigerant and water sides for pure counter-flow heat exchange and low refrigerant pressure drops. Both attributes contribute to the heat exchanger effectiveness and total unit's outstanding efficiency.

The external shell is covered with a 10mm closed cell insulation material. Each evaporator has 2 or 3 circuits, one for each compressor and is manufactured in accordance to PED approval. The evaporator water outlet connections are provided with Victaulic Kit (as standard).

Condenser coils

The condenser is manufactured with internally enhanced seamless copper tubes arranged in a staggered row pattern and mechanically expanded into lanced and rippled aluminium condenser fins with full fin collars. An integral sub-cooler circuit provides sub-cooling to effectively eliminate liquid flashing and increase in cooling capacity without increasing the power input.

Condenser coil fans

The condenser fans are propeller type with high efficiency design blades to maximize performances. The material of the blades is glass reinforced resin and each fan is protected by a guard. Fan motor is by circuit breaker installed inside the electrical panel as a standard. The motors are IP54.

Electronic expansion valve

The unit is equipped with the most advanced electronic expansion valves to achieve precise control of refrigerant mass flow. As today's system requires improved energy efficiency, tighter temperature control, wider range of operating conditions and incorporate features like remote monitoring and diagnostics, the application of electronic expansion valves becomes mandatory. Electronic expansion valve proposes features that make it unique: short opening and closing time, high resolution, positive shut-off function to eliminate use of additional solenoid valve, continuous modulation of mass flow without stress in the refrigerant circuit and corrosion resistance stainless steel body.

Electronic Expansion Valves are typically working with lower ΔP between high and low pressure side, than a thermostatic expansion valve. The electronic expansion valve allows the system to work with low condenser pressure (winter time) without any refrigerant flow problems and with a perfect chilled water leaving temperature control.

2 General characteristics

Refrigerant Circuit

Each unit has 2 or 3 independent refrigerant circuits and each one includes:

- Compressor with integrated oil separator
- Air Cooled Condenser
- Electronic expansion valve
- Evaporator
- Discharge line shut off valve
- Liquid line shut off valve
- Suction line shut off valve
- Sight glass with moisture indicator
- Filter drier
- Charging valves
- High pressure switch
- High and low pressure transducers

Electrical control panel

Power and control are located in two sections of the main panel that is manufactured to ensure protection against all weather conditions. The electrical panel is IP54 and (when opening the doors) internally protected with Plexiglas panel against possible accidental contact with electrical components (IP20). The main panel is fitted with a main switch interlocked door.

Power Section

The power section includes circuit breaker, compressors inverters, fans contactors, fans thermal overload relays, fans and control circuit transformer.

MicroTech II controller

MicroTech II C Plus controller is installed as standard; it can be used to modify unit set-points and check control parameters. A built-in display shows machine's operating status, programmable values, set-points, like temperatures and pressures of water, refrigerant and air. Device controls maximise the chiller energy efficiency and the reliability. A sophisticated software with predictive logic, select the most energy efficient combination of compressors, EEXV and condenser fans to keep stable operating conditions and maximise energy efficiency. The compressors are automatically rotated to ensure equal operating hours. MicroTech II C Plus protects critical components in response to external signals from its system sensors measuring: motor temperatures, refrigerant gas and oil pressures, correct phase sequence and evaporator.

Control section - main features

- Management of the compressor capacity, Inverter, slide and fans modulation.
- Chillers enabled to work in partial failure condition.
- Full routine operation at condition of:
 - high ambient temperature value,
 - high thermal load,
 - high evaporator entering water temperature (start-up).
- Display of evaporator entering/leaving water temperature.
- Display of condensing-evaporating temperature and pressure, suction and discharge superheat for each circuit.
- Leaving water cooled temperature regulation. Temperature tolerance = 0,1°C.
- Compressors and evaporator pumps hours counter.
- Display of Status Safety Devices.
- Start up numbers and compressors working hours equalization.
- Optimized management of compressors load.
- Fans management according to condensing pressure.
- Automatic re-start in case of power supply interruption (adjustable).
- Soft Load.
- Start at high evaporator water temperature.
- Return Reset.
- AOT Reset (optional).
- Set point Reset (optional).

2 General characteristics

Safety device / logic for each refrigerant circuit

- High pressure (pressure switch).
- Low pressure (transducer).
- Condensation fan Magneto-thermal.
- High Discharge Temperature on the compressor.
- Phase Monitor.
- Low pressure ratio.
- High oil pressure drop.
- Low oil pressure.

System security

- Phase monitor.
- Freeze protection.

Regulation type

Proportional + integral + derivative regulation on the leaving water evaporator output probe.

Condensing pressure

The condensation can be carried out according to temperature or pressure or pressure ratio. The fans can be managed according to a 0/10 V modulating signal.

Intelligent Compressor Start Mode

Control software includes an intelligent compressor start mode that unloads the first compressor to 75% during the start of the second one, in order to reduce inrush current.

MicroTech II C Plus terminal

MicroTech II C Plus built-in terminal has the following features.

- 4-lines by 20-character liquid crystal display back lighting.
- Key-pad consisting of 6 keys.
- Memory to protect the data.
- General faults alarm relays.
- Password access to modify the setting.
- Service report displaying all running hours and general conditions.
- Alarm history memory to allow an easy fault analysis.

Supervising systems (on request)

MicroTech II C Plus remote control

MicroTech II C Plus is able to communicate to BMS (Building Management System) based on the most common protocols as:

- CARELNative
- ModbusRTU
- LonWorks, now also based on the international 8040 Standard Chiller Profile and LonMark Technology
- BacNet BTP certified over IP and MS/TP (class 4)
- Ethernet TCP/IP and SNMP.

Standard accessories (supplied on basic unit)

Inverter compressor starter – For low inrush current and reduced starting torque.

Double set-point – Dual leaving water temperature set-points.

Fans circuit breaker thermal overload relays – Safety devices against motor overloading and short circuit in addition to the normal protection envisaged by the electrical windings.

Phase monitor – The phase monitor controls that phases sequence is correct and controls phase loss.

Evaporator Victaulic kit on water connection – Hydraulic joint with gasket for an easy and quick water connection.

2 General characteristics

10mm evaporator insulation

Evaporator electric heater – Electric heater controlled by a thermostat to protect the evaporator from freezing down to -28°C ambient temperature, providing the power supply is on.

Electronic expansion valve

Discharge line shut off valves – Installed on the discharge port of the compressor to facilitate maintenance operation.

Suction line shut off valve – Installed on the suction port of the compressor to facilitate maintenance operation.

Low pressure side manometers

Compressor hour run meter

General fault – Alarm relay.

Main switch interlock door

Options (on request)

Partial heat recovery – Produced with plate to plate heat exchangers installed between the compressor discharge and the condenser coil, allowing to produce hot water.

Brine version – Allows the unit to operate down to -8°C leaving liquid temperature (antifreeze required).

Under/Over Voltage – This device control the voltage value of power supply and stop the chiller if the value exceeds the allowed operating limits.

Energy Meter – This device allows to measure the energy absorbed by the chiller during its life. It is installed inside the control box mounted on a DIN rail and show on a digital display: Line-to-Line Voltage, Phase and Average Current, Active and Reactive Power, Active Energy, Frequency.

Current limit – To limit maximum absorbed current of the unit whenever is required

20mm evaporator insulation

Fan Silent Mode - The microprocessor clock switches the fan at low speed according to the client setting (i.e. Night & Day), providing that the ambient temperature/condensing pressure is allowing the speed change. It allows a perfect condensing control down to -10°C.

Fan speed regulation – To control the fan speed revolution for smooth operating control of the unit. This option improves the sound level of the unit during low ambient temperature operation.

Condenser coil guards

Cu-Cu condensing coils – To give better protection against corrosion by aggressive environments.

Cu-Cu-Sn condensing coils – To give better protection against corrosion in aggressive environments and by salty air.

Alucoat condensing coils – Fins are protected by a special acrylic paint with a high resistance to corrosion.

Evaporator Flow switch – Supplied separately to be wired and installed on the evaporator water piping (by the customer).

High pressure side manometers

Kit container

Rubber type antivibration mounts – Supplied separately, these are positioned under the base of the unit during installation. Ideal to reduce the vibrations when the unit is floor mounted.

Spring type antivibration mounts – Supplied separately, these are positioned under the base of the unit during installation. Ideal for dampening vibrations for installation on roofs and metallic structures.

Water circulation pump (low or high lifting) – Not available for 250÷290 BZSL units. Hydronic kit consists of: single direct driven centrifugal pump, water filling system with pressure gauge, safety valve, drain valve. The motor pump is protected by a circuit breaker installed in control panel. The kit is assembled and wired to the control panel. The pipe and pump are protected from freezing with an additional electrical heater.

Two water circulation pumps (low or high lifting) – Not available for 250÷290 BZSL units. Hydronic kit consists of: twin direct driven centrifugal pumps, water filling system with pressure gauge, safety valve, drain valve. The motor pump is protected by a circuit breaker installed in control panel. The kit is assembled and wired to the control panel. The pipe and pumps are protected from freezing with an additional electrical heater.

Set-point reset, demand limit and alarm from external device - The leaving water temperature set-point can be overwritten with the following options: 4-20mA from external source (by user); outside ambient temperature, evaporator water temperature Δt . Moreover the device allow the user to limit the load of the unit by 4-20mA signal or by network system and the microprocessor is able to receive an alarm signal from an external device (pump etc... -user can decide if this alarm signal will stop or not the unit).

Witness test – Every unit is always tested at the test bench prior to the shipment. On request, a second test can be carried out, at customer's presence, in accordance with the procedures indicated on the test form. (Not available for units with glycol mixtures).

Double pressure relief valve with diverter

Inertial tank with cabinet (500 l or 1000 l) - Piping to unit are not included and electric heater power supply has to be provided from external source.

3 Nomenclature

Nomenclature

Name	EWA	D	200	B	Z	S	L
Digits	1 2 3	4	5 6 7	8	9	10	11

<p>Machine type EWA = Air-cooled chiller, cooling only EWY = Air-cooled chiller, heat pump EWL = Remote condenser chiller ERA = Air cooled condensing unit EWW = Water-cooled chiller, cooling only EWC = Air-cooled chiller, cooling only with centrifugal fan EWR = Air-cooled chiller, cooling only with heat recovery</p>
<p>Refrigerant D = R-134a P = R-407c Q = R-410a</p>
<p>Capacity class in kW (Cooling) Always 3-digit code Idem as previous</p>
<p>Model series Letter A, B,... : major modification</p>
<p>Inverter - = Non-inverter Z = Inverter</p>
<p>Efficiency level S = Standard efficiency X = High efficiency P = Premium efficiency H = High ambient</p>
<p>Sound level S = Standard noise L = Low noise R = Reduced noise X = Extra low noise C = Cabinet</p>

4 Technical specifications

4-1 Technical Specifications			EWYD-BZSS	250	270	290	320	340	370	380	410	440	460	510	520	580
Capacity (1)(2)	Cooling	kW	254	273	292	324	339	365	382	413	436	457	505	522	583	
	Heating	kW	270	297	324	333	349	379	410	443	463	475	530	558	615	
Capacity control	Type	---	Stepless													
	Minimum capacity	%	13	13	13	13	13	13	13	13	13	13	9	9	9	9
Unit power input (1)(2)	Cooling	kW	90.3	100	109	116	124	134	142	152	163	161	178	186	215	
	Heating	kW	90.4	99	107	117	124	132	141	155	165	164	176	184	205	
EER (1)	---	2.81	2.74	2.69	2.79	2.74	2.73	2.68	2.72	2.68	2.83	2.83	2.81	2.71		
COP (2)	---	2.98	2.99	3.03	2.84	2.80	2.87	2.90	2.85	2.81	2.90	3.02	3.04	3.00		
ESEER	---	4.05	4.04	4.01	4.07	4.01	4.02	3.94	4.03	4.01	4.31	4.13	4.13	4.05		
IPLV	---	4.58	4.62	4.62	4.75	4.64	4.71	4.67	4.73	4.69	4.85	4.89	4.85	4.78		
Casing	Colour	---	Ivory White													
	Material	---	Galvanized and painted steel sheet													
Dimensions	Unit	Height	mm	2335	2335	2335	2335	2335	2335	2335	2335	2335	2335	2335	2335	2335
		Width	mm	2254	2254	2254	2254	2254	2254	2254	2254	2254	2254	2254	2254	2254
		Length	mm	3547	3547	3547	4381	4381	4381	4381	5281	5281	6583	6583	6583	6583
Weight	Unit	kg	3410	3455	3500	3870	3870	3940	4010	4390	4390	5015	5495	5735	5735	
	Operating Weight	kg	3550	3595	3640	4010	4010	4068	4138	4518	4518	5255	5724	5964	5953	
Water heat exchanger	Type	---	Single Pass Shell&Tube													
	Water volume	l	138	138	138	133	133	128	128	128	128	240	229	229	218	
	Nominal water flow rate	Cooling	l/s	12.12	13.03	13.95	15.46	16.21	17.42	18.25	19.72	20.81	21.83	24.11	24.92	27.87
		Heating	l/s	12.89	14.18	15.49	15.89	16.66	18.11	19.57	21.15	22.14	22.68	25.33	26.65	29.39
	Nominal Water pressure drop	Cooling	kPa	37	42	48	53	58	53	57	46	51	61	50	53	65
		Heating	kPa	42	49	58	55	60	57	65	52	57	66	55	60	71
Insulation material	---	Closed cell														
Air heat exchanger	Type	---	High efficiency fin and tube type with integral subcooler													
Fan	Type	---	Direct propeller type													
	Drive	---	DOL													
	Diameter	mm	800	800	800	800	800	800	800	800	800	800	800	800	800	800
	Nominal air flow	l/s	31728	31728	31728	42304	42304	42304	42304	52880	52880	63456	63456	63456	63456	
	Model	Quantity	No.	6	6	6	8	8	8	8	10	10	12	12	12	12
		Speed	rpm	920	920	920	920	920	920	920	920	920	920	920	920	920
Motor input		W	1.75	1.75	1.75	1.75	1.75	1.75	1.75	1.75	1.75	1.75	1.75	1.75	1.75	
Compressor	Type	---	Semi-hermetic single screw compressor Inverter driven													
	Oil charge	l	26	26	26	26	26	26	26	26	26	39	39	39	39	
	Quantity	No.	2	2	2	2	2	2	2	2	2	3	3	3	3	
Sound level	Sound Power	Cooling	dB(A)	100.5	100.5	100.5	101.2	101.2	101.2	101.2	101.8	101.8	103.6	103.6	103.6	103.6
		Heating	dB(A)	100.5	100.5	100.5	101.2	101.2	101.2	101.2	101.8	101.8	103.6	103.6	103.6	103.6
	Sound Pressure (3)	Cooling	dB(A)	82.1	82.1	82.1	82.3	82.3	82.3	82.3	82.5	82.5	83.7	83.7	83.7	83.7
		Heating	dB(A)	82.1	82.1	82.3	82.3	82.3	82.3	82.5	82.5	83.7	83.7	83.7	83.7	83.7
Refrigerant circuit	Refrigerant type	---	R-134a													
	Refrigerant charge	kg.	88	94	100	118	118	121	124	148	148	177	183	186	186	
	N. of circuits	No.	2	2	2	2	2	2	2	2	2	3	3	3	3	
Piping connections	Evaporator water inlet/outlet	mm	139.7	139.7	139.7	139.7	139.7	139.7	139.7	139.7	139.7	219.1	219.1	219.1	219.1	
Safety devices	High discharge pressure (pressure switch)															
	High discharge pressure (pressure transducer)															
	Low suction pressure (pressure transducer)															
	Compressor overload (Kriwan)															
	High discharge temperature															
	Low oil pressure															
	Low pressure ratio															
	High oil filter pressure drop															
	Phase monitor															
Notes (1)	Cooling capacity, unit power input in cooling and EER are based on the following conditions: evaporator 12/7°C; ambient 35°C, unit at full load operation.															
Notes (2)	Heating capacity, unit power input in heating and COP are based on the following conditions: condenser 40/45°C; ambient 7°C DB, unit at full load operation.															
Notes (3)	The values are according to ISO 3744 and are referred to: evaporator 12/7°C, ambient 35°C, full load operation.															

4 Technical specifications

4-1 Technical Specifications		EWYD-BZSS	250	270	290	320	340	370	380	410	440	460	510	520	580	
Power Supply	Phase	---	3													
	Frequency	Hz	50													
	Voltage	V	400													
	Voltage Tolerance	Minimum	%	-10%												
		Maximum	%	+10%												
Unit	Maximum starting current	A	217	217	217	264	296	296	296	334	358	328	398	430	430	
	Nominal running current cooling	A	150	167	181	196	209	224	237	255	273	271	300	313	357	
				153	167	178	197	210	222	235	260	276	275	296	309	342
	Maximum running current	A	238	238	238	285	324	324	324	362	392	369	447	486	486	
	Maximum current for wires sizing	A	262	262	262	314	356	356	356	398	431	406	492	535	535	
Fans	Nominal running current in cooling	A	4													
	Nominal running current in heating	A	4													
Compressor	Phase	No.	3													
	Voltage	V	400													
	Voltage Tolerance	Minimum	%	-10%												
		Maximum	%	+10%												
	Maximum running current	A	107+	107+	107+	107+	146+	146+	146+	146+	176+	176+	107+107	146+146	146+146	146+146
	Starting method	---	VFD													
Notes	Allowed voltage tolerance $\pm 10\%$. Voltage unbalance between phases must be within $\pm 3\%$.															
	Maximum starting current: starting current of biggest compressor + current of the compressor at 75% maximum load + fans current for the circuit at 75%.															
	Nominal current in cooling mode is referred to the following conditions: evaporator 12°C/7°C; ambient 35°C; compressors + fans current.															
	Nominal current in heating mode is referred to installation with 25kA short circuit current and is based on the following conditions: condenser 40°C/45°C; ambient 7°C DB/6°C WB + fans current.															
	Maximum running current is based on max compressor absorbed current in its envelope and max fans absorbed current															
Maximum current for wires sizing: (compressors full load ampere + fans current) x 1,1.																

4 Technical specifications

4-1 Technical Specifications		EWYD-BZSL	250	270	290	320	330	360	370	400	430	450	490	510	570	
Capacity (1) (2)	Cooling	kW	248	266	291	316	331	355	372	403	425	448	493	510	567	
	Heating	kW	270	297	324	333	349	379	410	443	463	475	530	558	615	
Capacity control	Type	---	Stepless													
	Minimum capacity	%	13	13	13	13	13	13	13	13	13	9	9	9	9	
Unit power input (1)(2)	Cooling	kW	88.5	98	109	113	122	132	142	149	161	156	174	183	214	
	Heating	kW	90.4	99	107	117	124	132	141	155	165	164	176	184	205	
EER (1)	---	2.80	2.70	2.66	2.79	2.72	2.68	2.62	2.71	2.64	2.87	2.83	2.79	2.65		
COP (2)	---	2.98	2.99	3.03	2.84	2.80	2.87	2.90	2.85	2.81	2.90	3.02	3.04	3.00		
ESEER	---	4.18	4.16	4.11	4.29	4.18	4.16	4.13	4.19	4.14	4.31	4.29	4.23	4.10		
IPLV	---	4.84	4.86	4.80	4.97	4.87	4.87	4.84	4.91	4.86	5.04	5.01	4.96	4.83		
Casing	Colour	---	Ivory White													
	Material	---	Galvanized and painted steel sheet													
Dimensions	Unit	Height	mm	2335	2335	2335	2335	2335	2335	2335	2335	2335	2335	2335	2335	
		Width	mm	2254	2254	2254	2254	2254	2254	2254	2254	2254	2254	2254	2254	
		Length	mm	3547	3547	3547	4381	4381	4381	4381	5281	5281	6583	6583	6583	6583
Weight	Unit	kg	3750	3795	3840	4210	4210	4280	4350	4730	4730	5525	6005	6245	6245	
	Operating Weight	kg	3888	3933	3978	4343	4343	4408	4478	4858	4858	5765	6234	6474	6463	
Water heat exchanger	Type	---	Single Pass Shell&Tube													
	Water volume	l	138	138	138	133	133	128	128	128	128	240	229	229	218	
	Nominal water flow rate	Cooling	l/s	11.83	12.70	13.89	15.12	15.83	16.98	17.77	19.28	20.30	21.39	23.56	24.34	27.11
		Heating	l/s	12.89	14.18	15.49	15.89	16.66	18.11	19.57	21.15	22.14	22.68	25.33	26.65	29.39
	Nominal Water pressure drop	Cooling	kPa	36	40	48	51	55	50.32	54.62	44.07	48.40	59.16	48	51	62
		Heating	kPa	42	49	58	55	60	57	65	52	57	66	55	60	71
Insulation material	0	Closed cell														
Air heat exchanger	Type	---	High efficiency fin and tube type with integral subcooler													
Fan	Type	---	Direct propeller type													
	Drive	---	DOL													
	Diameter	mm	800													
	Nominal air flow	Cooling	l/s	24432	24432	24432	32576	32576	32576	32576	40720	40720	48864	48864	48864	48864
		Heating	l/s	31728	31728	31728	42304	42304	42304	42304	52880	52880	63456	63456	63456	63456
	Model	Quantity	No.	6	6	6	8	8	8	8	10	10	12	12	12	12
		Speed - Cooling (Heating)	rpm	715 (920)	715 (920)	715 (920)	715 (920)	715 (920)	715 (920)	715 (920)	715 (920)	715 (920)	715 (920)	715 (920)	715 (920)	715 (920)
Motor input - Cooling (Heating)		W	0.78 (1.75)	0.78 (1.75)	0.78 (1.75)	0.78 (1.75)	0.78 (1.75)	0.78 (1.75)	0.78 (1.75)	0.78 (1.75)	0.78 (1.75)	0.78 (1.75)	0.78 (1.75)	0.78 (1.75)	0.78 (1.75)	
Compressor	Type	---	Semi-hermetic single screw compressor													
	Oil charge	l	26	26	26	26	26	26	26	26	26	39	39	39	39	
	Quantity	No.	2	2	2	2	2	2	2	2	2	3	3	3	3	
Sound level	Sound Power	Cooling	dB(A)	94.0	94.0	94.0	94.7	94.7	94.7	94.7	95.3	95.3	97.0	97.0	97.0	97.0
		Heating	dB(A)	94.9	94.9	94.9	96.1	96.1	96.1	96.1	96.7	96.7	98.4	98.4	98.4	98.4
	Sound Pressure (3)	Cooling	dB(A)	75.6	75.6	75.6	75.8	75.8	75.8	75.8	76.0	76.0	77.2	77.2	77.2	77.2
		Heating	dB(A)	76.5	76.5	76.5	77.2	77.2	77.2	77.2	77.4	77.4	78.6	78.6	78.6	78.6
Refrigerant circuit	Refrigerant type	---	R-134a													
	Refrigerant charge	kg.	88	94	100	118	118	121	124	148	148	177	183	186	186	
	N. of circuits	No.	2	2	2	2	2	2	2	2	2	3	3	3	3	
Piping connections	Evaporator water inlet/outlet	mm	139.7	139.7	139.7	139.7	139.7	139.7	139.7	139.7	139.7	219.1	219.1	219.1	219.1	
Safety devices	High discharge pressure (pressure switch)															
	High discharge pressure (pressure transducer)															
	Low suction pressure (pressure transducer)															
	Compressor overload (Kriwan)															
	High discharge temperature															
	Low oil pressure															
	Low pressure ratio															
	High oil filter pressure drop															
	Phase monitor															
Notes (1)	Cooling capacity, unit power input in cooling and EER are based on the following conditions: evaporator 12/7°C; ambient 35°C, unit at full load operation.															
Notes (2)	Heating capacity, unit power input in heating and COP are based on the following conditions: condenser 40/45°C; ambient 7°C DB, unit at full load operation.															
Notes (3)	The values are according to ISO 3744 and are referred to: evaporator 12/7°C, ambient 35°C, full load operation.															

4 Technical specifications

4-3 Technical Specifications			EWYD-BZSL		250	270	290	320	330	360	370	400	430	450	490	510	570	
Power Supply	Phase	---	3															
	Frequency	Hz	50															
	Voltage	V	400															
	Voltage Tolerance	Minimum	%	-10%														
		Maximum	%	+10%														
Unit	Maximum starting current	A	208	208	208	252	284	285	284	319	343	310	380	412	412			
	Nominal running current cooling	A	149	160	147	153	167	178	192	200	219	232	255	269	311			
	Nominal running current heating	A	153	167	178	197	210	222	235	260	276	275	296	309	342			
	Maximum running current	A	238	238	238	285	324	324	324	362	392	369	447	486	486			
	Maximum current for wires sizing	A	262	262	262	314	356	356	356	398	431	406	492	535	535			
Fans	Nominal running current in cooling	A	3															
	Nominal running current in heating	A	4															
Compressor	Phase	No.	3															
	Voltage	V	400															
	Voltage Tolerance	Minimum	%	-10%														
		Maximum	%	+10%														
	Maximum running current	A	107+	107+	107+	107+	146+	146+	146+	146+	176+	176+	107+107	146+146	146+146	146+146	146+146	
	Starting method	---	Wye – Delta type (Y –)															
Notes	Allowed voltage tolerance $\pm 10\%$. Voltage unbalance between phases must be within $\pm 3\%$.																	
	Maximum starting current: starting current of biggest compressor + current of the compressor at 75% maximum load + fans current for the circuit at 75%.																	
	Nominal current in cooling mode is referred to installation with 25kA short circuit current and is based on the following conditions: evaporator 12°C/7°C; ambient 35°C.compressor + fans current.																	
	Nominal current in heating mode is referred to installation with 25kA short circuit current and is based on the following conditions: condenser 40°C/45°C; ambient 7°C DB/6°C WB + fans current.																	
	Maximum running current is based on max compressor absorbed current in its envelope and max fans absorbed current																	
Maximum current for wires sizing: (compressors full load ampere + fans current) x 1,1.																		

5 Sound Levels

Sound Levels

EWYD-BZ - Cooling

EWYD-BZSS

Unit size		Sound pressure level at 1 m from the unit in semispheric free field (rif. 2 x 10 ⁻⁵ Pa)									Power
		63 Hz	125 Hz	250 Hz	500 Hz	1000 Hz	2000 Hz	4000 Hz	8000 Hz	dB(A)	dB(A)
250+290	Rated	77,0	75,6	75,8	74,9	81,1	69,3	60,7	51,9	82,1	100,5
	Min	77,0	75,1	73,8	74,0	72,2	66,2	58,9	49,5	75,9	94,4
	Boost	77,4	78,6	79,1	80,7	79,5	74,7	66,5	58,0	83,1	101,5
320+380	Rated	77,2	75,8	76,0	75,1	81,3	69,5	60,9	52,1	82,3	101,2
	Min	77,2	75,3	74,0	74,2	72,4	66,4	59,1	49,7	76,1	95,0
	Boost	78,5	79,7	80,2	81,8	80,6	75,8	67,6	59,1	84,2	103,1
410+440	Rated	77,4	76,0	76,2	75,3	81,5	69,7	61,1	52,3	82,5	101,8
	Min	77,4	75,5	74,2	74,4	72,6	66,6	59,3	49,9	76,3	95,7
	Boost	78,7	79,9	80,4	82,0	80,8	76,0	67,8	59,3	84,4	103,7
460+580	Rated	78,6	77,2	77,4	76,5	82,7	70,9	62,3	53,5	83,7	103,6
	Min	78,6	76,7	75,4	75,6	73,8	67,8	60,5	51,1	77,5	97,4
	Boost	79,9	81,1	81,6	83,2	82,0	77,2	69,0	60,5	85,6	105,4

EWYD-BZSL

Unit size		Sound pressure level at 1 m from the unit in semispheric free field (rif. 2 x 10 ⁻⁵ Pa)									Power
		63 Hz	125 Hz	250 Hz	500 Hz	1000 Hz	2000 Hz	4000 Hz	8000 Hz	dB(A)	dB(A)
250+290	Rated	76,1	72,4	70,9	69,6	74,2	63,9	55,5	46,3	75,6	94,0
	Min	76,1	72,5	70,5	69,8	68,6	62,8	55,1	45,7	72,3	90,7
	Boost	76,2	73,6	72,8	73,7	72,6	67,7	59,5	50,8	76,2	94,6
320+370	Rated	76,3	72,6	71,1	69,8	74,4	64,1	55,7	46,5	75,8	94,7
	Min	76,3	72,7	70,7	70,0	68,8	63,0	55,3	45,9	72,5	91,4
	Boost	76,4	73,8	73,0	73,9	72,8	67,9	59,7	51,0	76,4	95,3
400+430	Rated	76,5	72,8	71,3	70,0	74,6	64,3	55,9	46,7	76,0	95,3
	Min	76,5	72,9	70,9	70,2	69,0	63,2	55,5	46,1	72,7	92,0
	Boost	76,6	74,0	73,2	74,1	73,0	68,1	59,9	51,2	76,6	95,9
450+570	Rated	77,7	74,0	72,5	71,2	75,8	65,5	57,1	47,9	77,2	97,0
	Min	77,7	74,1	72,1	71,4	70,2	64,4	56,7	47,3	73,9	93,7
	Boost	77,8	75,2	74,4	75,3	74,2	69,3	61,1	52,4	77,8	97,6

NOTES

- Rated (nominal frequency)
- Min (minimum frequency)
- Boost (maximum frequency)

5 Sound Levels

Sound Levels

EWYD~BZ - Heating

EWYD~BZSS

Unit size		Sound pressure level at 1 m from the unit in semispheric free field (rif. 2 x 10 ⁻⁵ Pa)								Power	
		63 Hz	125 Hz	250 Hz	500 Hz	1000 Hz	2000 Hz	4000 Hz	8000 Hz	dB(A)	dB(A)
250÷290	Rated	77,0	75,6	75,8	74,9	81,1	69,3	60,7	51,9	82,1	100,5
	Min	77,0	75,1	73,8	74,0	72,2	66,2	58,9	49,5	75,9	94,4
	Boost	77,4	78,6	79,1	80,7	79,5	74,7	66,5	58,0	83,1	101,5
320÷380	Rated	77,2	75,8	76,0	75,1	81,3	69,5	60,9	52,1	82,3	101,2
	Min	77,2	75,3	74,0	74,2	72,4	66,4	59,1	49,7	76,1	95,0
	Boost	78,5	79,7	80,2	81,8	80,6	75,8	67,6	59,1	84,2	103,1
410÷440	Rated	77,4	76,0	76,2	75,3	81,5	69,7	61,1	52,3	82,5	101,8
	Min	77,4	75,5	74,2	74,4	72,6	66,6	59,3	49,9	76,3	95,7
	Boost	78,7	79,9	80,4	82,0	80,8	76,0	67,8	59,3	84,4	103,7
460÷580	Rated	78,6	77,2	77,4	76,5	82,7	70,9	62,3	53,5	83,7	103,6
	Min	78,6	76,7	75,4	75,6	73,8	67,8	60,5	51,1	77,5	97,4
	Boost	79,9	81,1	81,6	83,2	82,0	77,2	69,0	60,5	85,6	105,4

EWYD~BZSL

Unit size		Sound pressure level at 1 m from the unit in semispheric free field (rif. 2 x 10 ⁻⁵ Pa)								Power	
		63 Hz	125 Hz	250 Hz	500 Hz	1000 Hz	2000 Hz	4000 Hz	8000 Hz	dB(A)	dB(A)
250÷290	Rated	78,1	74,1	72,3	70,8	74,8	65,1	56,8	47,5	76,5	94,9
	Min	78,1	74,1	71,8	70,9	69,9	64,2	56,4	46,9	73,5	91,9
	Boost	78,1	74,9	73,7	74,1	73,2	68,2	60,0	51,2	76,7	95,1
320÷370	Rated	79,5	75,5	74,1	71,5	75,1	67,6	59,6	51,0	77,2	96,1
	Min	78,3	74,3	72,0	71,1	70,1	64,4	56,6	47,1	73,7	92,6
	Boost	78,3	75,1	73,9	74,3	73,4	68,4	60,2	51,4	76,9	95,8
400÷430	Rated	79,7	75,7	74,3	71,7	75,3	67,8	59,8	51,2	77,4	96,7
	Min	78,5	74,5	72,2	71,3	70,3	64,6	56,8	47,3	73,9	93,2
	Boost	78,5	75,3	74,1	74,5	73,6	68,6	60,4	51,6	77,1	96,4
450÷570	Rated	80,9	76,9	75,5	72,9	76,5	69,0	61,0	52,4	78,6	98,4
	Min	79,7	75,7	73,4	72,5	71,5	65,8	58,0	48,5	75,1	94,9
	Boost	79,7	76,5	75,3	75,7	74,8	69,8	61,6	52,8	78,3	98,1

NOTES

- Rated (nominal frequency)
- Min (minimum frequency)
- Boost (maximum frequency)

5 Sound Levels

Sound pressure level correction factors for different distances

EWYD-BZ

EWYD-BZSS / EWYD-BZSL

Unit size		Distance						
BZSS	BZSL	1m	5m	10m	15m	20m	25m	50m
250	250	0,0	6,2	10,3	13,0	15,1	16,8	22,2
270	270	0,0	6,2	10,3	13,0	15,1	16,8	22,2
290	290	0,0	6,2	10,3	13,0	15,1	16,8	22,2
320	320	0,0	5,9	9,9	12,6	14,7	16,4	21,8
340	330	0,0	5,9	9,9	12,6	14,7	16,4	21,8
370	360	0,0	5,9	9,9	12,6	14,7	16,4	21,8
380	370	0,0	5,9	9,9	12,6	14,7	16,4	21,8
410	400	0,0	5,7	9,6	12,3	14,3	16,0	21,4
440	130	0,0	5,7	9,6	12,3	14,3	16,0	21,4
460	450	0,0	5,4	9,3	11,9	13,9	15,6	20,9
510	490	0,0	5,4	9,3	11,9	13,9	15,6	20,9
520	510	0,0	5,4	9,3	11,9	13,9	15,6	20,9
580	570	0,0	5,4	9,3	11,9	13,9	15,6	20,9

6 Operating limits

Cooling Mode

EWYD~BZSS and EWYD~BZSL

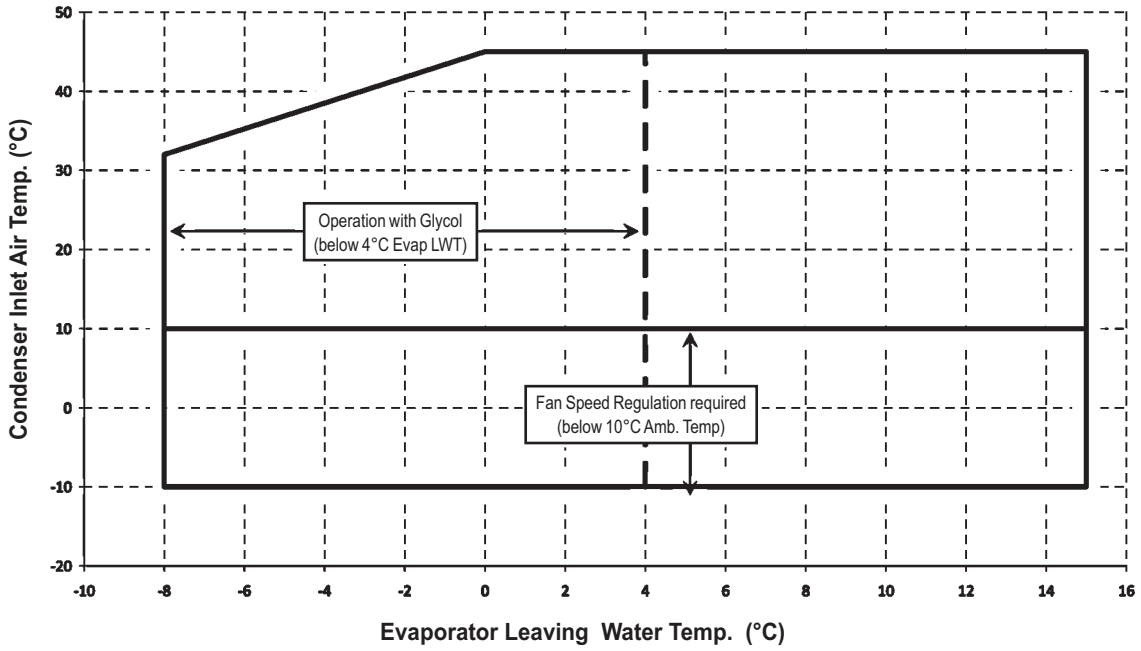

Heating Mode

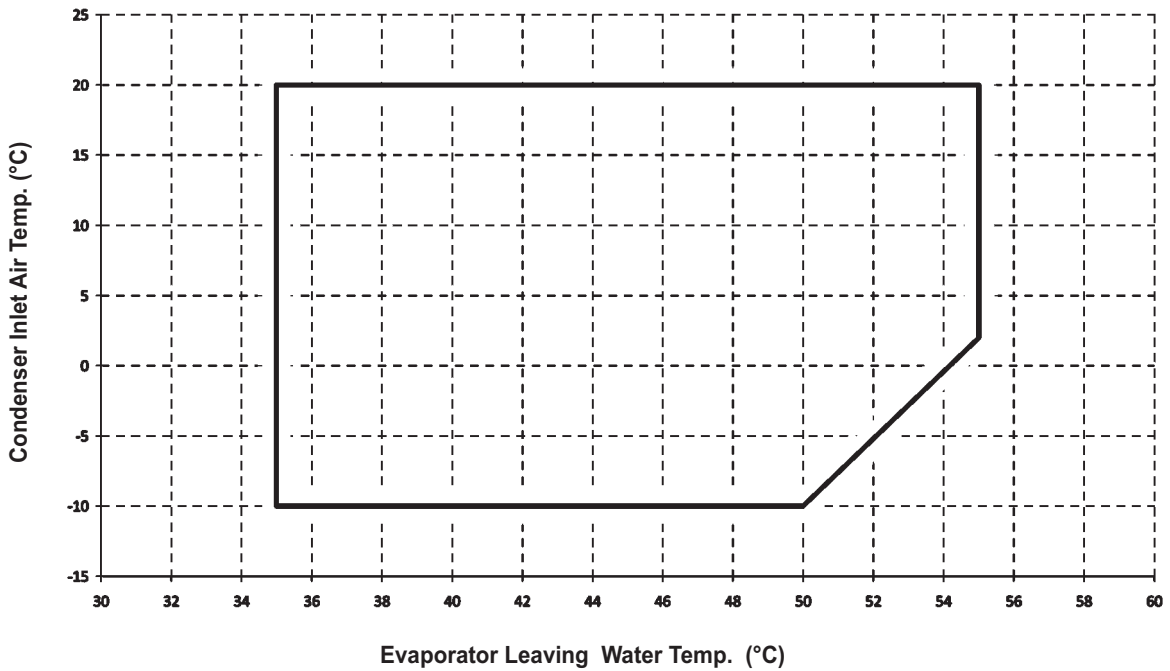

6 Operating limits

EWYD-BZ

Water heat exchanger - Minimum and maximum water Δt

Max evaporator water Δt	°C	8
Min evaporator water Δt	°C	4

Note: Table referred to Cooling and Heating Mode

Water heat exchanger - Fouling factors

Fouling factors m ² °C / kW	Cooling capacity correction factor	Power input correction factor	EER correction factor
0,0176	1,000	1,000	1,000
0,0440	0,978	0,986	0,992
0,0880	0,957	0,974	0,983
0,1320	0,938	0,962	0,975

Note: Table referred to Cooling and Heating Mode

Air heat exchanger - Altitude correction factors

Elevation above sea level (m)	0	300	600	900	1200	1500	1800
Barometric pressure (mbar)	1013	977	942	908	875	843	812
Cooling capacity correction factor	1,000	0,993	0,986	0,979	0,973	0,967	0,960
Power input correction factor	1,000	1,005	1,009	1,015	1,021	1,026	1,031

Note: Table referred to Cooling Mode only

Note: Maximum operating altitude is 2000 m above sea level

Note: Contact factory in case the unit has to be installed at altitudes between 1000 and 2000 m above sea level

Minimum glycol percentage for low water temperature

Evaporator Leaving Water Temperature (°C)	2	0	-2	-4	-6	-8
Ethylene glycol (%)	10	20	20	20	30	30
Propylene glycol (%)	10	20	20	30	30	30

Note: Table referred to Cooling Mode only

Note: Minimum glycol percentage to be used with evaporator leaving water temperature below 4°C to prevent freezing of water circuit.

Minimum glycol percentage for low air ambient temperature

Air Ambient Temperature (°C) (2)	-3	-8	-15	-20
Ethylene glycol (%) (1)	10%	20%	30%	40%
Air Ambient Temperature (°C) (2)	-3	-7	-12	-20
Propylene glycol (%) (1)	10%	20%	30%	40%

Minimum glycol percentage to prevent freezing of water circuit at indicated air ambient temperature

Air ambient temperature do exceed the operating limits of the unit, as protection of water circuit may be needed in winter season at non-working conditions.

Correction factors for low evaporator leaving water temperature

Evaporator Leaving Water Temperature (°C)	2	0	-2	-4	-6	-8
Cooling Capacity	0,842	0,785	0,725	0,670	0,613	0,562
Compressor Power Input	0,950	0,940	0,920	0,890	0,870	0,840

Note: Table referred to Cooling Mode only

Note: Correction factors have to be applied at working conditions: evaporator leaving water temperature 7°C

Correction factors for water and glycol mixture

	Ethylene Glycol (%)	10%	20%	30%	40%	50%
Ethylene Glycol	Cooling Capacity	0,991	0,982	0,972	0,961	0,946
	Compressor Power Input	0,996	0,992	0,986	0,976	0,966
	Flow Rate (Δt)	1,013	1,04	1,074	1,121	1,178
	Evaporator Pressure Drop	1,070	1,129	1,181	1,263	1,308
Propylene Glycol	Cooling Capacity	0,985	0,964	0,932	0,889	0,846
	Compressor Power Input	0,993	0,983	0,969	0,948	0,929
	Flow Rate (Δt)	1,017	1,032	1,056	1,092	1,139
	Evaporator Pressure Drop	1,120	1,272	1,496	1,792	2,128

Note: Table referred to Cooling Mode only

Note: In Heating mode correction factor is 1 at water temperature between operating limits

Note: Contact factory for water temperature out of operating limits

6 Operating limits

EWYD-BZ

How to use the Correction factors proposed in the previous tables

A) Mixture Water and Glycol --- Evaporator leaving water temperature > 4°C

- depending from the type and percentage (%) of glycol filled in the circuit (see table 4.2 and 6)
- multiply the Cooling Capacity, the Compressor Power Input by the Correction factor of Table 6
- starting from this new value of Cooling Capacity, calculate the Flow Rate (l/s) and the Evaporator Pressure Drop (kPa)
- now multiply the new Flow Rate and the new Evaporator Pressure Drop by the Correction Factors of Table 6

Example:

Unit Size: EWYD250BZSS

- Mixture: Water
- Working condition: ELWT 12/7°C – Condenser inlet air temperature 35°C
- Cooling capacity: 254 kW (Rated conditions)
 - Power input: 90.3 kW (Rated conditions)
 - Flow rate (Δt 5°C): 12.12 l/ss
 - Evaporator pressure drop: 37 kPa

- Mixture: Water + Ethylene Glycol 30% (for a winter air temperature up to -15°C)
- Working condition: ELWT 12/7°C - Condenser inlet air temperature 35°C
- Cooling capacity: $254 \times 0.972 = 247 \text{ kW}$
 - Power input: $90.3 \times 0.986 = 89.0 \text{ kW}$
 - Flow rate (Δt 5°C): 11.80 (referred to 247 kW) $\times 1.074 = 12.67 \text{ l/s}$
 - Evaporator pressure drop: 40 (referred to 12.67 l/s) $\times 1.181 = 47 \text{ kPa}$

B) Mixture Water and Glycol --- Evaporator leaving water temperature < 4°C

- depending from the type and percentage (%) of glycol filled in the circuit (see table 4.1 and 4.2 and table 6)
- depending from the evaporator leaving water temperature (see table 5)
- multiply the Cooling Capacity, the Compressor Power Input by the Correction factor of Table 5 and Table 6
- starting from this new value of Cooling Capacity, calculate the Flow Rate (l/s) and the Evaporator Pressure Drop (kPa)
- now multiply the new Flow Rate and the new Evaporator Pressure Drop by the Correction Factors of Table 6

Example:

Unit Size: EWYD250BZSS

- Mixture: Water
- Working condition: ELWT 12/7°C – Condenser inlet air temperature 30°C
- Cooling capacity: 265 kW (Rated conditions)
 - Power input: 83.3 kW (Rated conditions)
 - Flow rate (Δt 5°C): 12.66 l/s
 - Evaporator pressure drop: 40 kPa

- Mixture: Water + Glycol 30% (for a low evaporator leaving temperature of -1/-6°C)
- Working condition: ELWT -1/-6°C – Condenser inlet air temperature 30°C
- Cooling capacity: $265 \times 0.613 \times 0.972 = 158 \text{ kW}$
 - Power input: $83.3 \times 0.870 \times 0.986 = 71.5 \text{ kW}$
 - Flow rate (Δt 5°C): 7.54 l/s (referred to 158 kW) $\times 1.074 = 8.10 \text{ l/s}$
 - Evaporator pressure drop: 18 kPa (referred to 8.10 l/s) $\times 1.181 = 21 \text{ kPa}$

OPL_1-2-3-4-5-6a-7-8_Rev.01_3

6 Operating limits

Water charge, flow and quality

Items ^{(1),(5)}	Cooling Water			Cooled Water		Heated water ⁽²⁾				Tendency if out of criteria
	Circulating System		Once Flow Flowing water	Circulating water [Below 20°C]	Supply water ⁽⁴⁾	Low temperature		High temperature		
	Circulating water	Supply water ⁽⁴⁾				Circulating water [20°C ~ 60°C]	Supply water ⁽⁴⁾	Circulating water [60°C ~ 80°C]	Supply water ⁽⁴⁾	
pH	at 25°C	6.5 ~ 8.2	6.0 ~ 8.0	6.0 ~ 8.0	6.0 ~ 8.0	7.0 ~ 8.0	7.0 ~ 8.0	7.0 ~ 8.0	7.0 ~ 8.0	Corrosion + Scale
Electrical conductivity	[mS/m] at 25°C	Below 80	Below 30	Below 40	Below 40	Below 30	Below 30	Below 30	Below 30	Corrosion + Scale
	[µS/cm] at 25°C	(Below 800)	(Below 300)	(Below 400)	(Below 400)	(Below 300)	(Below 300)	(Below 300)	(Below 300)	Corrosion + Scale
Chloride ion	[mgCl ₂ -l]	Below 200	Below 50	Below 50	Below 50	Below 50	Below 50	Below 30	Below 30	Corrosion
Sulfate ion	[mgSO ₂ -l]	Below 200	Below 50	Below 50	Below 50	Below 50	Below 50	Below 30	Below 30	Corrosion
M-alkalinity (pH4.8)	[mgCaCO ₃ -l]	Below 100	Below 50	Below 50	Below 50	Below 50	Below 50	Below 50	Below 50	Scale
Total hardness	[mgCaCO ₃ -l]	Below 200	Below 70	Below 70	Below 70	Below 70	Below 70	Below 70	Below 70	Scale
Calcium harness	[mgCaCO ₃ -l]	Below 150	Below 50	Below 50	Below 50	Below 50	Below 50	Below 50	Below 50	Scale
Silica ion	[mgSiO ₂ -l]	Below 50	Below 30	Below 30	Below 30	Below 30	Below 30	Below 30	Below 30	Scale
Iron	[mgFe-l]	Below 1.0	Below 0.3	Below 1.0	Below 1.0	Below 0.3	Below 1.0	Below 0.3	Below 1.0	Corrosion + Scale
Copper	[mgCu-l]	Below 0.3	Below 0.1	Below 1.0	Below 1.0	Below 1.0	Below 1.0	Below 0.1	Below 1.0	Corrosion
Sulfite ion	[mgS ₂ -l]	Not detectable	Not detectable	Not detectable	Not detectable	Not detectable	Not detectable	Not detectable	Not detectable	Corrosion
Ammonium ion	[mgNH ₄ -l]	Below 1.0	Below 0.1	Below 1.0	Below 1.0	Below 0.1	Below 0.3	Below 0.1	Below 0.1	Corrosion
Remaining chloride	[mgCl-l]	Below 0.3	Below 0.3	Below 0.3	Below 0.3	Below 0.3	Below 0.25	Below 0.3	Below 0.1	Corrosion
Free carbide	[mgCO ₂ -l]	Below 4.0	Below 4.0	Below 4.0	Below 4.0	Below 4.0	Below 0.4	Below 4.0	Below 4.0	Corrosion
Stability index		6.0 ~ 7.0	---	---	---	---	---	---	---	Corrosion + Scale

- Names, definitions and units are according to JIS K 0101. Units and figures between brackets are old units published as reference only.
- In case of using heated water (more than 40°C), corrosion is generally noticeable.
Especially when the iron materials is in direct contact with water without any protection shields, it is desirable to give the valid measure for corrosion. E.g. chemical measure
- In the cooling water using hermetic cooling tower, close circuit water is according to heated water standard, and scattered water is according to cooling water standard.
- Supply water is considered drink water, industrial water and ground water except for genuine water, neutral water and soft water.
- The above mentioned items are representable items in corrosion and scale cases.

Water content in cooling circuits

The cooled water distribution circuits should have minimum water content to avoid excessive compressors start and stop. In fact, each time the compressor starts up, an excessive quantity of oil goes from the compressor sump and simultaneously there is a rise in the temperature of the compressor motor's stator due to the inrush current during the start-up. To prevent damage to the compressors, we have envisaged the application of a device to limit frequent stops and restarts.

During the span of one hour there will be no more than 6 starts of the compressor. The plant side should therefore ensure that the overall water content allows a more constant functioning of the unit and consequently greater environmental comfort. The minimum water content per unit should be calculated using this simplified formula:

For 2 compressors unit
 $M \text{ (liters)} = (0.1595 \times \Delta T(^{\circ}\text{C}) + 3.0825) \times P(\text{kW})$

For 3 compressors unit
 $M \text{ (liters)} = (0.0443 \times \Delta T(^{\circ}\text{C}) + 1.6202) \times P(\text{kW})$

where:
 M minimum water content per unit expressed in litres
 P Cooling Capacity of the unit expressed in kW
 ΔT evaporator entering / leaving water temperature difference expressed in °C

This formula is valid for:
 - standard microprocessor parameters

For more accurate determination of quantity of water, it is advisable to contact the designer of the plant.

6 Operating limits

EWYD-BZ

Automatic and Manual Boost --- Cooling Mode

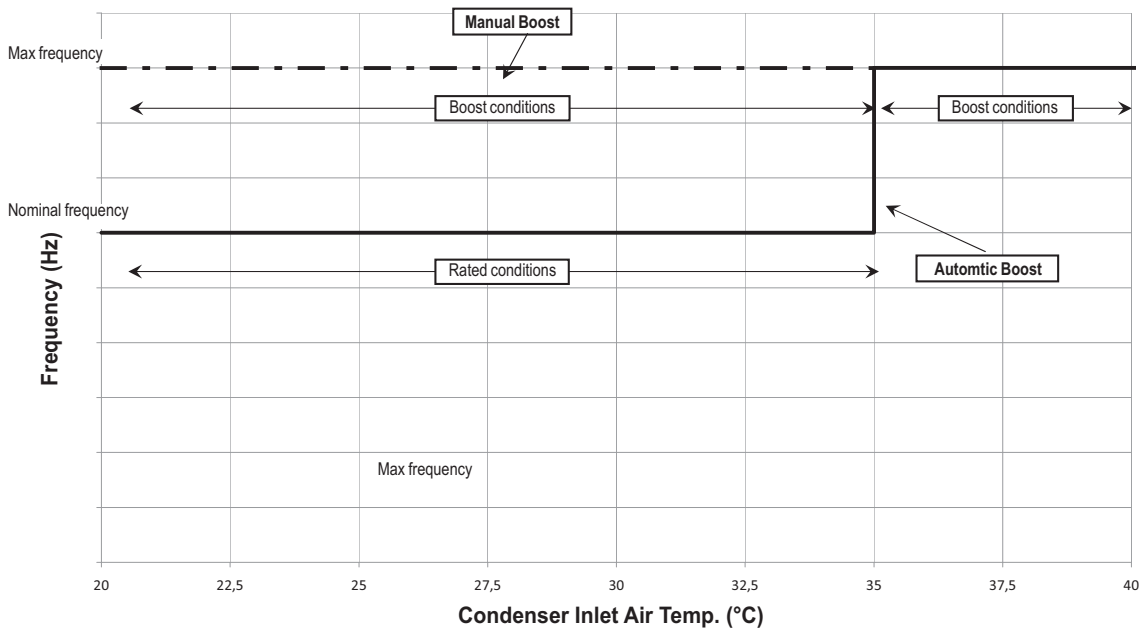

NOTES

1. Automatic boost: unit standard configuration
2. Manual boost: customized configuration by different settings
3. Rated conditions: compressors are working at nominal frequency
4. Boost conditions: compressors are working at the maximum frequency
5. Both automatic and manual boost maximum frequency depends on the maximum current suppliable by the inverter

Automatic and Manual Boost --- Heating Mode

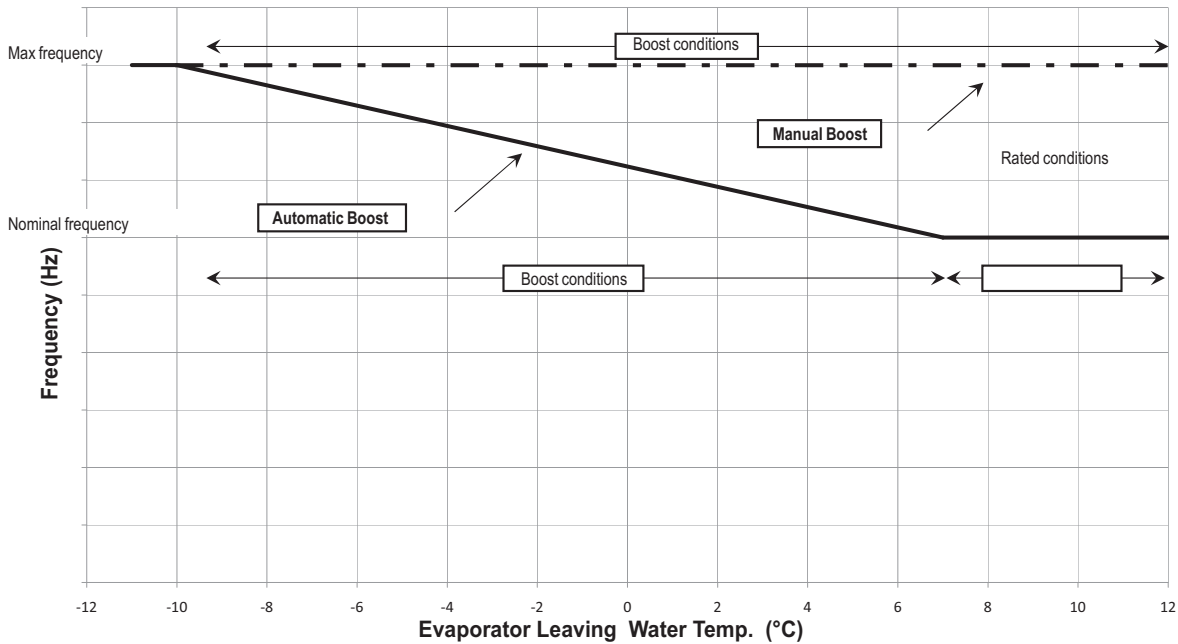

NOTES

1. Automatic boost: unit standard configuration
2. Manual boost: customized configuration by different settings
3. Rated conditions: compressors are working at nominal frequency
4. Boost conditions: compressors are working at the maximum frequency
5. Manual boost: customized configuration by different settings
6. Both automatic and manual boost maximum frequency depends on the maximum current suppliable by the inverter

OPL_1-2-3-4-5-6a-7-8_Rev.01_6

6 Operating limits

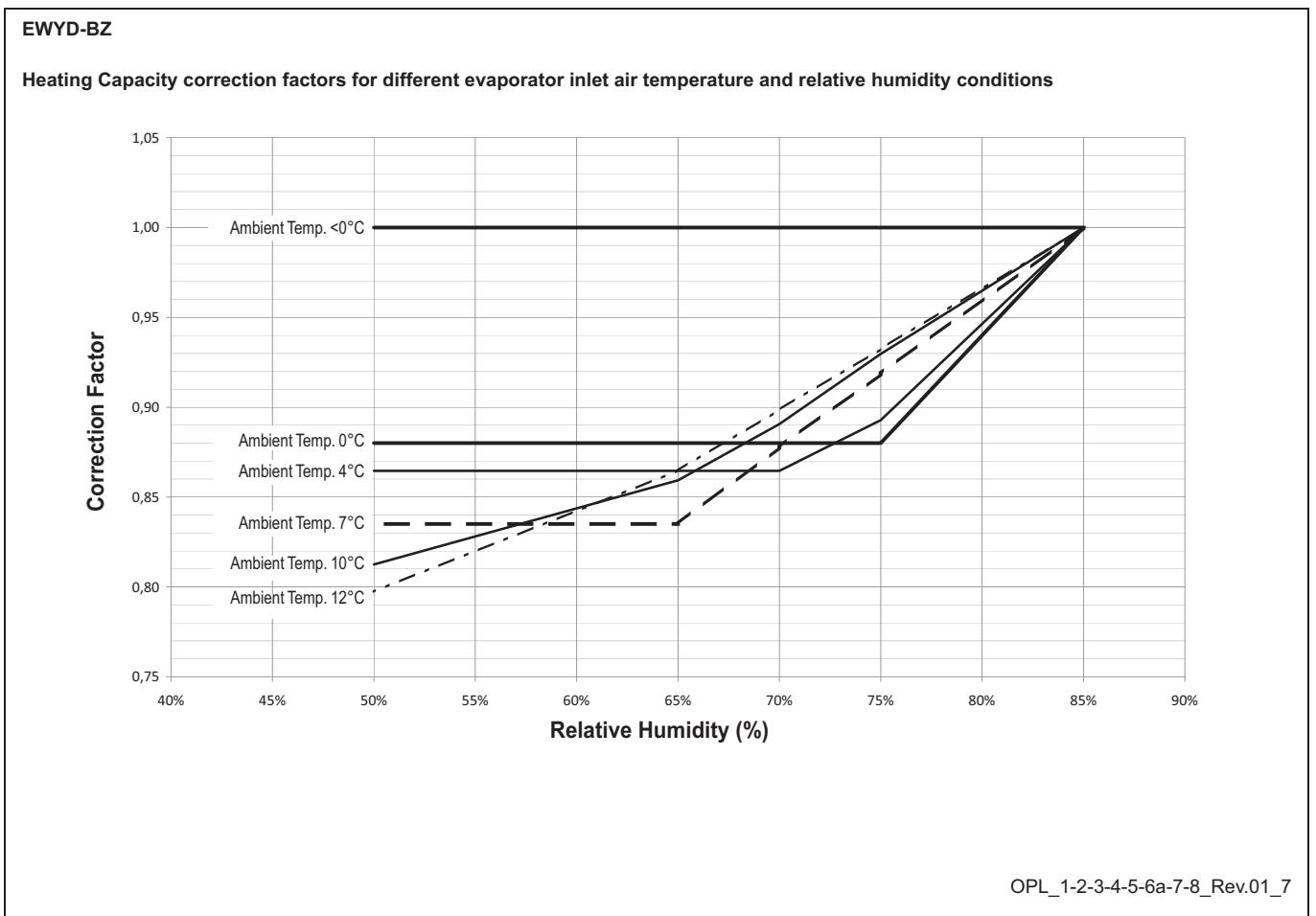

6 Operating limits

EWYD-BZ

Integrated Heating Capacity - Automatic Boost

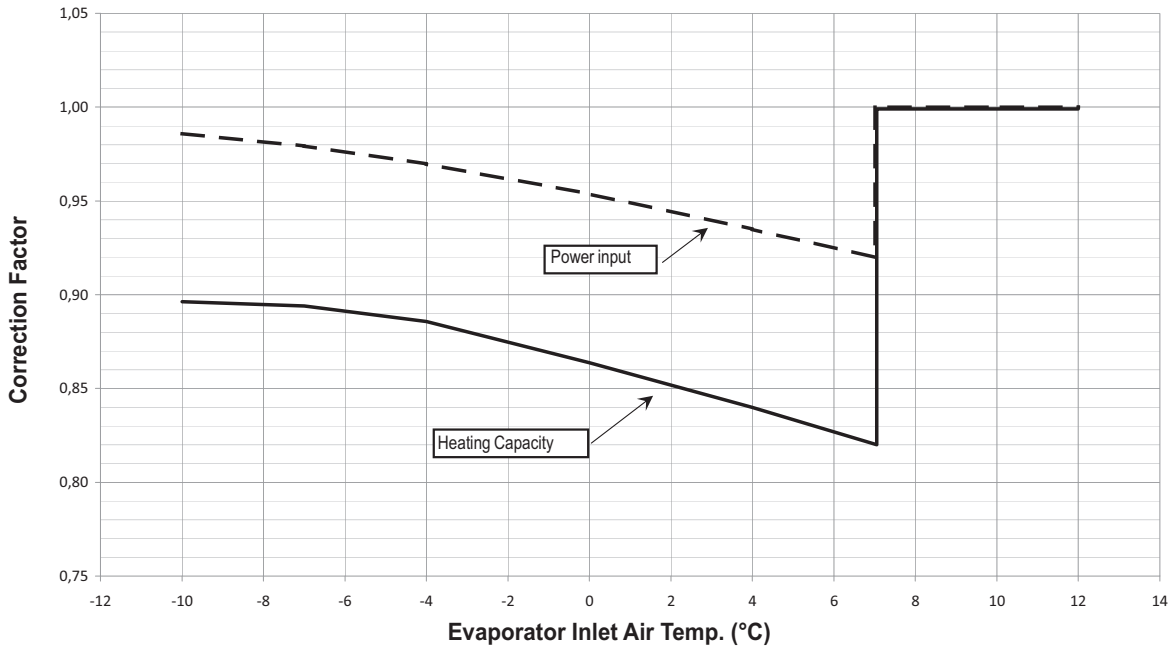

NOTES

- Correction factors to be applied to Standard Ratings in Heating Mode (Relative Humidity: 85% with evaporator inlet air temperature above 0°C ; 100% with evaporator inlet air temperature below 0°C)

Integrated Heating Capacity - Manual Boost

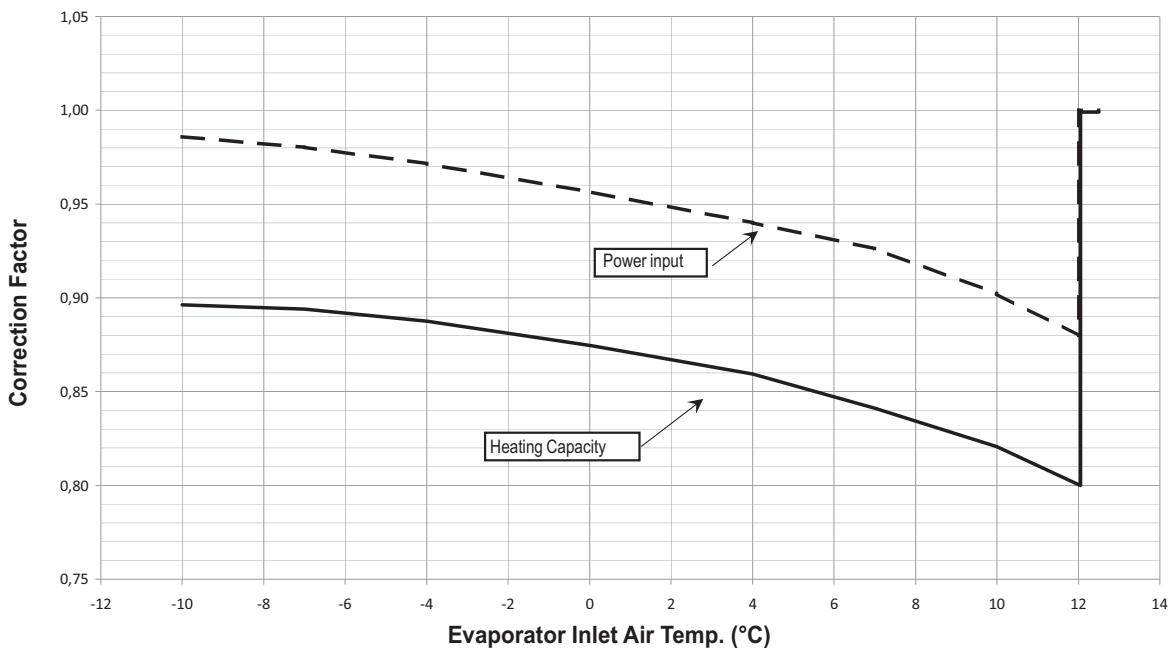

NOTES

- Correction factors to be applied to Standard Ratings in Heating Mode (Relative Humidity: 85% with evaporator inlet air temperature above 0°C ; 100% with evaporator inlet air temperature below 0°C)

OPL_1-2-3-4-5-6a-7-8_Rev.01_8

7 Standard rating

7 - 1 Cooling capacity tables

EWYD-BZSS																		
Size	ELWT (°C)	Condenser Inlet Air Temperature (°C)																
		20				25				30				35				
		Rated		Boost		Rated		Boost		Rated		Boost		Rated		Boost		
		Cc (kW)	Pi (kW)	Cc (kW)	Pi (kW)	Cc (kW)	Pi (kW)	Cc (kW)	Pi (kW)	Cc (kW)	Pi (kW)	Cc (kW)	Pi (kW)	Cc (kW)	Pi (kW)	Cc (kW)	Pi (kW)	
250	4	263	68,3	358	114	253	74,1	343	125	242	80,4	326	134	231	87,3	295	132	
	5	271	69,1	368	116	261	75,0	353	127	250	81,4	333	134	239	88,4	304	134	
	6	279	69,9	378	118	268	75,9	363	129	258	82,3	339	133	246	89,3	311	133	
	7	287	70,9	388	119	276	76,8	373	130	265	83,3	346	133	254	90,3	317	133	
	8	295	71,8	398	121	284	77,8	383	132	273	84,2	353	133	261	91,4	323	132	
	9	303	72,7	409	122	293	78,7	393	134	281	85,3	360	132	269	92,4	333	134	
	10	312	73,6	419	124	301	79,7	400	133	289	86,3	370	134	277	93,4	339	133	
	11	320	74,6	430	126	309	80,7	408	133	298	87,3	377	133	285	94,5	345	133	
	12	329	75,6	440	128	318	81,7	415	133	306	88,4	383	133	293	95,6	352	132	
	13	338	76,5	451	130	327	82,7	422	132	314	89,5	390	132	301	96,7	361	133	
	14	347	77,6	462	131	335	83,8	433	134	323	90,5	400	134	310	97,8	367	133	
	15	356	78,6	473	133	344	84,9	440	133	332	91,7	407	133	318	99,0	374	132	
	270	4	283	74,8	377	124	273	81,4	355	129	261	88,5	318	133	249	96,2	300	132
		5	291	75,8	386	124	281	82,4	363	130	269	89,5	326	133	257	97,3	309	134
		6	300	76,7	397	126	289	83,4	372	130	277	90,6	334	134	265	98,4	315	133
7		309	77,7	406	126	297	84,4	382	132	285	91,6	341	133	273	100	322	132	
8		317	78,7	415	127	306	85,4	391	133	294	92,7	347	133	281	101	330	133	
9		326	79,8	424	128	315	86,5	399	133	302	93,8	354	132	289	102	337	133	
10		335	80,8	433	128	323	87,6	407	133	311	95,0	363	134	297	103	343	133	
11		344	81,9	444	130	332	88,7	416	133	320	96,1	370	133	306	104	351	133	
12		353	82,9	453	131	341	89,8	423	133	328	97,3	376	132	315	105	357	132	
13		363	84,0	462	131	350	91,0	430	132	337	98,5	384	133	323	107	365	133	
14		372	85,2	471	132	360	92,1	439	133	346	100	392	133	332	108	373	133	
15		382	86,3	481	133	369	93,3	448	134	355	101	399	133	341	109	379	132	
290		4	304	81,4	397	133	292	88,7	366	133	280	96,5	336	133	267	105	305	132
		5	312	82,5	405	132	301	89,8	374	133	288	97,7	342	132	275	106	314	134
		6	321	83,5	416	134	309	90,9	381	132	297	98,8	352	134	283	107	320	133
	7	330	84,6	423	133	318	92,0	391	134	306	100	359	133	292	109	326	132	
	8	340	85,7	431	133	327	93,1	398	133	314	101	366	133	300	110	336	134	
	9	349	86,8	439	133	336	94,3	406	133	323	102	372	132	309	111	342	133	
	10	358	88,0	446	132	346	95,5	413	132	332	104	382	133	318	112	348	132	
	11	368	89,1	457	134	355	96,7	423	134	341	105	389	133	327	114	357	134	
	12	378	90,3	465	134	365	97,9	430	133	351	106	395	132	336	115	363	133	
	13	388	91,5	473	133	374	99,2	437	132	360	107	405	134	345	116	369	131	
	14	397	92,7	480	133	384	100	444	132	370	109	412	133	354	118	379	133	
	15	407	94,0	488	132	394	102	455	134	379	110	418	132	364	119	385	132	
	320	4	335	87,6	452	145	322	95	427	154	309	103	396	157	295	112	361	157
		5	345	88,7	465	147	332	96	437	155	319	105	404	157	305	113	369	157
		6	355	89,7	475	148	342	97	449	157	328	106	412	156	314	115	378	157
7		365	90,8	486	149	352	98	459	157	338	107	423	158	324	116	387	158	
8		375	91,9	499	151	362	100	468	157	348	108	431	157	333	117	395	157	
9		386	93,0	510	152	372	101	477	156	358	109	440	157	343	118	404	157	
10		396	94,2	521	153	383	102	487	157	368	110	450	157	353	120	411	156	
11		407	95,3	532	154	393	103	498	157	378	112	459	158	363	121	421	157	
12		418	96,5	543	155	404	104	507	157	389	113	468	157	373	122	430	157	
13		429	97,7	557	157	415	106	515	156	400	114	478	157	383	124	437	156	
14		440	98,9	568	158	425	107	526	157	410	116	485	156	394	125	447	157	
15		451	100	577	157	437	108	537	158	421	117	495	157	404	126	456	157	

NOTES

Cc (cooling capacity) - Pi (unit power input) – ELWT (evaporator leaving water temperature – Δt 5°C).
 Data are referred to 0,0176 m² °C/kW evaporator fouling factor
 Rated conditions are for compressors running at nominal frequency.
 Boost conditions are for compressors running at maximum frequency.
 10% glycol is recommend for shaded area conditions

7 Standard rating

7 - 1 Cooling capacity tables

EWYD-BZSS

Size	ELWT (°C)	Condenser Inlet Air Temperature (°C)												
		36				40				45				
		Rated		Boost		Rated		Boost		Rated		Boost		
		Cc (kW)	Pi (kW)	Cc (kW)	Pi (kW)	Cc (kW)	Pi (kW)	Cc (kW)	Pi (kW)	Cc (kW)	Pi (kW)	Cc (kW)	Pi (kW)	
250	4	290	132	290	132	270	134	270	134	230	122	230	122	
	5	299	134	299	134	276	133	276	133	238	123	238	123	
	6	305	133	305	133	282	133	282	133	243	122	243	122	
	7	311	133	311	133	288	132	288	132	251	124	251	124	
	8	318	132	318	132	296	134	296	134	256	123	256	123	
	9	326	134	326	134	302	133	302	133	261	122	261	122	
	10	333	133	333	133	308	132	308	132	269	123	269	123	
	11	340	133	340	133	317	134	317	134	274	122	274	122	
	12	346	132	346	132	323	133	323	133	282	123	282	123	
	13	355	133	355	133	329	132	329	132	287	122	287	122	
	14	361	133	361	133	338	134	338	134	295	124	295	124	
	15	367	132	367	132	343	133	343	133	300	123	300	123	
	270	4	295	132	295	132	273	134	273	134	232	122	232	122
		5	303	134	303	134	279	133	279	133	240	123	240	123
		6	310	133	310	133	287	133	287	133	245	122	245	122
7		316	132	316	132	292	133	292	133	253	123	253	123	
8		324	133	324	133	300	133	300	133	258	122	258	122	
9		331	133	331	133	307	133	307	133	264	123	264	123	
10		337	133	337	133	313	132	313	132	270	123	270	123	
11		345	133	345	133	322	134	322	134	277	123	277	123	
12		351	132	351	132	327	133	327	133	283	123	283	123	
13		359	132	359	132	333	132	333	132	290	123	290	123	
14		367	133	367	133	342	133	342	133	296	123	296	123	
15		373	132	373	132	347	132	347	132	303	123	303	123	
290		4	299	132	299	132	253	114	277	133	235	122	235	122
		5	308	134	308	134	261	116	283	132	242	123	242	123
		6	315	133	315	133	269	117	292	134	247	122	247	122
	7	321	132	321	132	277	118	297	133	255	123	255	123	
	8	329	133	329	133	286	119	303	132	260	122	260	122	
	9	336	133	336	133	294	121	312	133	268	123	268	123	
	10	342	132	342	132	303	122	317	132	272	122	272	122	
	11	351	134	351	134	311	123	326	134	280	123	280	123	
	12	357	133	357	133	320	125	332	133	285	122	285	122	
	13	363	131	363	131	329	126	337	131	293	123	293	123	
	14	372	133	372	133	338	128	346	133	297	121	297	121	
	15	378	132	378	132	347	129	351	132	306	123	306	123	
	320	4	354	157	354	157	327	157	327	157	281	147	281	147
		5	362	156	362	156	334	156	334	156	289	147	289	147
		6	371	157	371	157	344	158	344	158	296	147	296	147
7		380	157	380	157	351	157	351	157	304	147	304	147	
8		388	157	388	157	360	157	360	157	310	145	310	145	
9		397	157	397	157	368	157	368	157	319	147	319	147	
10		405	156	405	156	377	158	377	158	325	146	325	146	
11		413	157	413	157	384	156	384	156	335	147	335	147	
12		423	157	423	157	392	157	392	157	341	146	341	146	
13		430	156	430	156	401	157	401	157	350	147	350	147	
14		439	156	439	156	408	156	408	156	356	146	356	146	
15		449	157	449	157	419	158	419	158	366	147	366	147	

NOTES

Cc (cooling capacity) - Pi (unit power input) – ELWT (evaporator leaving water temperature – Δt 5°C).
 Data are referred to 0,0176 m² °C/kW evaporator fouling factor
 Rated conditions are for compressors running at nominal frequency.
 Boost conditions are for compressors running at maximum frequency.
 10% glycol is recommend for shaded area conditions

7 Standard rating

7 - 1 Cooling capacity tables

EWYD-BZSS		Condenser Inlet Air Temperature (°C)																
		20				25				30				35				
		Rated		Boost		Rated		Boost		Rated		Boost		Rated		Boost		
Size	ELWT (°C)	Cc (kW)	Pi (kW)	Cc (kW)	Pi (kW)	Cc (kW)	Pi (kW)	Cc (kW)	Pi (kW)	Cc (kW)	Pi (kW)	Cc (kW)	Pi (kW)	Cc (kW)	Pi (kW)	Cc (kW)	Pi (kW)	
340	4	351	93,4	472	156	339	102	453	171	325	110	424	178	310	120,1	388	178	
	5	362	94,5	485	158	349	103	466	174	335	112	433	177	320	121,4	397	177	
	6	372	95,6	498	160	359	104	478	176	345	113	442	176	329	122,6	405	176	
	7	383	96,8	511	163	369	105	491	178	355	114	454	179	339	124,0	416	179	
	8	393	98,0	524	165	380	106	501	177	365	115	463	178	349	125,3	425	178	
	9	404	99,2	537	167	390	108	510	177	375	117	472	177	359	126,7	433	177	
	10	415	100	551	169	401	109	519	176	386	118	480	177	370	128,1	441	176	
	11	426	102	564	171	412	110	533	178	397	119	493	179	380	129,5	453	178	
	12	438	103	578	174	423	111	542	178	407	121	502	178	391	130,9	461	177	
	13	449	104	592	176	434	113	551	177	418	122	510	177	401	132,4	469	176	
	14	461	106	606	178	445	114	560	176	429	124	519	176	412	133,8	481	178	
	15	472	107	616	178	457	116	574	178	440	125	532	178	423	135,3	489	177	
	370	4	378	100	504	167	364	109	475	175	349	119	438	177	333	129,4	399	177
		5	389	102	518	170	375	111	486	176	360	120	447	176	343	130,8	409	177
		6	401	103	530	170	386	112	499	179	370	122	458	177	354	132,2	419	178
7		412	104	542	171	397	113	509	178	381	123	468	178	365	133,7	428	177	
8		424	106	554	172	409	115	519	177	392	124	477	177	375	135,2	438	178	
9		435	107	566	173	420	116	528	176	404	126	486	176	386	136,7	446	176	
10		447	108	580	175	432	118	540	177	415	127	497	177	397	138,3	456	177	
11		459	110	592	176	443	119	551	178	427	129	508	177	409	139,9	467	178	
12		471	111	604	177	455	120	561	177	438	131	517	176	420	141,5	475	176	
13		484	113	615	176	467	122	570	176	450	132	528	177	431	143,1	485	177	
14		496	114	625	176	480	123	582	177	462	134	539	178	443	144,8	495	177	
15		509	116	639	178	492	125	594	178	474	135	547	177	455	146,5	503	176	
380		4	397	107	522	176	382	116	483	177	366	126	443	177	349	137,8	403	176
		5	409	108	537	178	393	118	492	176	377	128	452	176	360	139,3	415	178
		6	420	109	547	178	405	119	506	179	388	129	465	178	371	140,8	423	177
	7	432	111	557	177	416	120	515	178	400	131	473	178	382	142,4	431	176	
	8	444	112	567	177	428	122	525	177	411	132	482	177	393	144,0	444	178	
	9	456	114	577	176	440	123	534	176	423	134	491	176	405	145,6	452	177	
	10	468	115	592	178	452	125	548	179	435	136	504	178	416	147,3	460	176	
	11	481	117	602	178	464	127	557	178	446	137	513	177	428	149,0	472	178	
	12	493	118	612	177	477	128	567	177	459	139	521	176	439	150,7	480	177	
	13	506	120	622	177	489	130	576	176	471	141	535	178	451	152,5	488	175	
	14	519	121	632	176	502	131	590	178	483	142	543	177	463	154,3	501	178	
	15	532	123	647	178	514	133	599	177	496	144	551	176	476	156,1	508	176	
	410	4	427	114	572	191	412	124	534	196	395	135	491	197	377	147	449	197
		5	440	116	588	193	424	126	545	195	407	137	501	196	389	149	458	196
		6	452	117	603	195	436	127	557	196	419	138	511	195	401	150	469	196
7		465	118	617	196	449	129	570	197	431	140	525	197	413	152	480	197	
8		478	120	628	196	461	130	581	196	444	141	535	196	425	153	489	195	
9		491	121	642	197	474	132	591	195	456	143	545	195	437	155	501	196	
10		504	123	653	196	487	133	607	197	469	144	560	198	450	157	512	196	
11		518	124	664	195	500	135	617	196	482	146	569	196	462	158	521	195	
12		531	126	678	196	514	136	628	196	495	148	579	195	475	160	535	197	
13		545	127	689	196	527	138	640	196	508	149	594	198	488	162	544	196	
14		559	129	703	197	541	140	654	197	522	151	603	196	501	164	553	195	
15		573	131	714	196	555	141	664	196	535	153	613	195	514	165	567	197	

NOTES

Cc (cooling capacity) - Pi (unit power input) - ELWT (evaporator leaving water temperature - Δt 5°C).
 Data are referred to 0,0176 m² °C/kW evaporator fouling factor
 Rated conditions are for compressors running at nominal frequency.
 Boost conditions are for compressors running at maximum frequency.
 10% glycol is recommend for shaded area conditions

7 Standard rating

7 - 1 Cooling capacity tables

EWYD-BZSS

Size	ELWT (°C)	Condenser Inlet Air Temperature (°C)												
		36				40				45				
		Rated		Boost		Rated		Boost		Rated		Boost		
		Cc (kW)	Pi (kW)	Cc (kW)	Pi (kW)	Cc (kW)	Pi (kW)	Cc (kW)	Pi (kW)	Cc (kW)	Pi (kW)	Cc (kW)	Pi (kW)	
340	4	381	178	381	178	352	177,7	352	178	307	461,0	307	168	
	5	389	177	389	177	360	176,7	360	177	314	466,5	314	166	
	6	398	177	398	177	371	178,8	371	179	324	478,3	324	168	
	7	409	178	409	178	379	177,7	379	178	331	483,7	331	167	
	8	417	177	417	177	386	176,7	386	177	337	489,0	337	166	
	9	426	177	426	177	398	178,7	398	179	348	500,9	348	167	
	10	434	176	434	176	405	177,6	405	178	354	506,1	354	166	
	11	445	178	445	178	413	176,4	413	176	365	518,2	365	168	
	12	453	177	453	177	424	178,5	424	178	371	523,1	371	166	
	13	461	176	461	176	431	177,2	431	177	382	535,5	382	168	
	14	473	178	473	178	439	176,0	439	176	388	540,3	388	166	
	15	481	177	481	177	450	178,0	450	178	398	552,7	398	168	
	370	4	392	177	392	177	362	177,2	362	177	313	166,1	313	166
		5	402	177	402	177	372	177,6	372	178	323	167,9	323	168
		6	411	178	411	178	379	176,5	379	176	330	166,4	330	166
7		420	177	420	177	389	177,0	389	177	341	168,2	341	168	
8		430	178	430	178	398	177,3	398	177	347	166,7	347	167	
9		439	177	439	177	408	177,8	408	178	356	166,9	356	167	
10		448	177	448	177	416	176,5	416	176	364	166,9	364	167	
11		459	178	459	178	427	178,6	427	179	373	167,1	373	167	
12		467	177	467	177	435	177,2	435	177	381	167,1	381	167	
13		476	177	476	177	442	175,8	442	176	390	167,2	390	167	
14		487	177	487	177	454	177,9	454	178	399	167,2	399	167	
15		495	176	495	176	462	176,4	462	176	407	167,3	407	167	
380		4	396	177	396	177	366	178,1	366	178	315	166,3	315	166
		5	407	178	407	178	374	176,8	374	177	326	168,0	326	168
		6	415	177	415	177	382	175,5	382	175	332	166,4	332	166
	7	424	176	424	176	393	177,5	393	177	343	168,1	343	168	
	8	435	178	435	178	401	176,1	401	176	349	166,5	349	166	
	9	444	177	444	177	412	178,1	412	178	360	168,2	360	168	
	10	452	176	452	176	420	176,7	420	177	366	166,5	366	166	
	11	464	178	464	178	431	178,7	431	179	377	168,2	377	168	
	12	472	177	472	177	439	177,2	439	177	383	166,4	383	166	
	13	479	176	479	176	446	175,7	446	176	394	168,1	394	168	
	14	492	178	492	178	458	177,7	458	178	400	166,3	400	166	
	15	500	176	500	176	465	176,1	465	176	411	168,0	411	168	
	410	4	437	194	437	194	393	185,7	393	186	352	186,0	352	186
		5	447	194	447	194	403	186,2	403	186	360	184,3	360	184
		6	458	194	458	194	411	184,7	411	185	371	186,2	371	186
7		469	195	469	195	424	186,7	424	187	378	184,4	378	184	
8		478	193	478	193	432	185,2	432	185	390	186,3	390	186	
9		489	194	489	194	442	185,2	442	185	397	184,5	397	185	
10		500	194	500	194	452	185,6	452	186	409	186,3	409	186	
11		509	193	509	193	462	185,6	462	186	416	184,4	416	184	
12		523	195	523	195	473	186,0	473	186	428	186,3	428	186	
13		532	194	532	194	483	186,0	483	186	435	184,4	435	184	
14		541	193	541	193	493	186,3	493	186	448	186,2	448	186	
15		554	194	554	194	501	184,6	501	185	457	186,0	457	186	

NOTES

Cc (cooling capacity) - Pi (unit power input) – ELWT (evaporator leaving water temperature – Δt 5°C).
 Data are referred to 0,0176 m²/kW evaporator fouling factor
 Rated conditions are for compressors running at nominal frequency.
 Boost conditions are for compressors running at maximum frequency.
 10% glycol is recommend for shaded area conditions

7 Standard rating

7 - 1 Cooling capacity tables

EWYD-BZSS																		
Size	ELWT (°C)	Condenser Inlet Air Temperature (°C)																
		20				25				30				35				
		Rated		Boost		Rated		Boost		Rated		Boost		Rated		Boost		
		Cc (kW)	Pi (kW)	Cc (kW)	Pi (kW)	Cc (kW)	Pi (kW)	Cc (kW)	Pi (kW)	Cc (kW)	Pi (kW)	Cc (kW)	Pi (kW)	Cc (kW)	Pi (kW)	Cc (kW)	Pi (kW)	
440	4	452	122	602	206	435	133	562	211	417	145	517	212	398	158	472	212	
	5	465	124	618	209	448	135	573	211	430	147	528	211	411	159	482	210	
	6	478	125	634	211	461	136	584	210	443	148	538	210	423	161	496	213	
	7	491	127	646	211	474	138	600	212	455	150	553	213	436	163	505	212	
	8	505	128	658	210	487	139	611	211	468	152	563	212	448	165	515	210	
	9	519	130	675	213	501	141	622	210	482	153	573	211	461	166	529	213	
	10	533	132	687	212	514	143	638	213	495	155	589	213	474	168	539	212	
	11	547	133	699	211	528	145	649	212	508	157	599	212	487	170	548	210	
	12	561	135	710	211	542	146	660	211	522	159	609	211	501	172	563	213	
	13	575	137	722	210	556	148	671	210	536	160	624	213	514	174	572	211	
	14	590	138	739	213	570	150	687	213	550	162	635	212	528	176	581	210	
	15	605	140	751	212	585	152	698	212	564	164	645	211	542	178	596	212	
	460	4	472	122	640	201	455	133	592	203	436	144	544	205	417	156	495	204
		5	486	124	658	203	468	134	609	206	450	146	555	204	430	158	505	203
		6	500	125	675	206	482	136	621	205	463	147	571	206	443	160	520	206
7		514	127	688	205	496	137	633	204	477	149	582	205	457	161	530	204	
8		529	128	701	205	511	139	650	206	491	150	593	204	471	163	540	203	
9		544	130	714	204	525	140	662	206	506	152	609	206	485	165	556	205	
10		559	131	727	203	540	142	674	205	520	154	620	205	499	166	566	204	
11		574	133	745	206	555	144	685	204	535	155	631	204	513	168	582	206	
12		590	134	758	205	570	145	703	206	549	157	647	206	527	170	592	205	
13		605	136	771	205	585	147	715	205	564	159	658	205	542	172	601	203	
14		621	138	783	204	601	149	726	204	580	161	669	204	557	174	617	205	
15		637	139	796	203	617	150	738	204	595	162	686	206	572	175	627	204	
510		4	522	135	708	225	503	146	672	240	482	159	623	246	460	173	569	246
		5	537	136	726	226	518	148	689	242	497	161	638	246	475	174	582	246
		6	553	138	746	229	533	150	707	244	512	163	651	245	490	176	595	245
	7	569	140	764	231	549	152	724	246	527	164	664	244	505	178	610	246	
	8	585	141	782	233	565	153	738	245	543	166	680	246	520	180	624	246	
	9	602	143	801	235	581	155	754	246	559	168	695	246	535	182	636	245	
	10	619	145	819	238	597	157	768	245	575	170	708	245	551	184	647	244	
	11	636	147	838	240	614	159	786	247	591	172	721	244	567	186	665	247	
	12	653	149	857	242	631	161	799	246	607	174	740	247	583	188	677	245	
	13	670	151	878	245	648	163	815	246	624	176	752	245	599	190	691	245	
	14	688	153	893	244	665	165	829	245	641	178	765	244	615	193	707	246	
	15	706	155	912	247	682	167	843	244	658	180	784	247	632	195	719	245	
	520	4	540	140	730	235	520	152	701	257	499	166	656	267	476	180	600	267
		5	556	142	750	238	536	154	721	261	514	168	670	266	491	182	613	266
		6	572	144	770	241	552	156	741	264	530	169	683	265	506	184	626	265
7		589	145	791	244	568	158	761	267	545	171	697	264	522	186	644	268	
8		605	147	812	247	584	160	776	266	561	173	716	268	537	188	656	267	
9		622	149	833	251	601	162	790	265	578	175	730	266	553	190	669	266	
10		639	151	854	254	617	164	805	264	594	177	743	265	569	192	682	264	
11		657	153	875	258	634	166	825	268	611	179	757	264	585	194	700	267	
12		674	155	897	261	652	168	840	267	627	181	777	267	602	196	713	266	
13		692	157	918	265	669	170	855	266	644	184	790	266	618	199	725	264	
14		710	159	934	264	687	172	869	265	662	186	804	264	635	201	744	267	
15		729	161	956	268	705	174	883	264	679	188	824	268	652	203	757	266	

NOTES

Cc (cooling capacity) - Pi (unit power input) – ELWT (evaporator leaving water temperature – Δt 5°C).
 Data are referred to 0,0176 m² °C/kW evaporator fouling factor
 Rated conditions are for compressors running at nominal frequency.
 Boost conditions are for compressors running at maximum frequency.
 10% glycol is recommend for shaded area conditions

7 Standard rating

7 - 1 Cooling capacity tables

EWYD-BZSS

Size		ELWT (°C)		Condenser Inlet Air Temperature (°C)											
				36				40				45			
				Rated		Boost		Rated		Boost		Rated		Boost	
		Cc (kW)	Pi (kW)	Cc (kW)	Pi (kW)	Cc (kW)	Pi (kW)	Cc (kW)	Pi (kW)	Cc (kW)	Pi (kW)	Cc (kW)	Pi (kW)		
440	4	460	209	460	209	414	200	414	200	373	202	373	202		
	5	471	209	471	209	427	202	427	202	381	200	381	200		
	6	484	210	484	210	436	200	436	200	393	202	393	202		
	7	494	210	494	210	449	203	449	203	401	200	401	200		
	8	503	209	503	209	457	201	457	201	413	202	413	202		
	9	517	210	517	210	465	199	465	199	421	200	421	200		
	10	527	210	527	210	479	201	479	201	433	202	433	202		
	11	536	208	536	208	487	200	487	200	441	200	441	200		
	12	550	211	550	211	500	202	500	202	454	202	454	202		
	13	559	209	559	209	508	200	508	200	461	200	461	200		
	14	569	208	569	208	522	202	522	202	474	202	474	202		
	15	583	210	583	210	530	200	530	200	481	200	481	200		
	460	4	485	204	485	204	446	204	446	204	379	188	379	188	
		5	496	204	496	204	461	206	461	206	391	190	391	190	
		6	510	205	510	205	470	204	470	204	399	188	399	188	
7		521	205	521	205	484	206	484	206	412	190	412	190		
8		531	203	531	203	494	205	494	205	419	188	419	188		
9		545	205	545	205	503	203	503	203	433	189	433	189		
10		556	204	556	204	517	206	517	206	440	188	440	188		
11		571	206	571	206	527	204	527	204	453	189	453	189		
12		581	205	581	205	541	206	541	206	460	187	460	187		
13		591	203	591	203	550	204	550	204	474	189	474	189		
14		606	205	606	205	559	203	559	203	488	191	488	191		
15		617	204	617	204	574	205	574	205	495	189	495	189		
510		4	558	246	558	246	516	246	516	246	445	231	445	231	
		5	571	246	571	246	527	245	527	245	455	229	455	229	
		6	584	245	584	245	542	246	542	246	469	231	469	231	
	7	599	246	599	246	554	246	554	246	479	229	479	229		
	8	612	246	612	246	566	245	566	245	490	229	490	229		
	9	625	245	625	245	582	247	582	247	503	230	503	230		
	10	637	244	637	244	593	246	593	246	515	229	515	229		
	11	654	246	654	246	606	245	606	245	528	230	528	230		
	12	666	245	666	245	621	247	621	247	539	229	539	229		
	13	679	245	679	245	632	245	632	245	552	230	552	230		
	14	695	246	695	246	644	245	644	245	564	229	564	229		
	15	707	245	707	245	660	246	660	246	580	232	580	232		
	520	4	589	267	589	267	544	266	544	266	473	251	473	251	
		5	601	266	601	266	556	265	556	265	484	249	484	249	
		6	615	265	615	265	573	268	573	268	499	252	499	252	
7		632	268	632	268	585	267	585	267	510	250	510	250		
8		644	266	644	266	596	265	596	265	520	248	520	248		
9		658	266	658	266	614	268	614	268	536	251	536	251		
10		670	265	670	265	626	266	626	266	546	249	546	249		
11		688	267	688	267	637	265	637	265	562	251	562	251		
12		701	266	701	266	655	268	655	268	572	249	572	249		
13		714	264	714	264	667	266	667	266	588	252	588	252		
14		731	267	731	267	678	264	678	264	598	250	598	250		
15		744	266	744	266	696	267	696	267	615	252	615	252		

NOTES

Cc (cooling capacity) - Pi (unit power input) – ELWT (evaporator leaving water temperature – Δt 5°C).
 Data are referred to 0,0176 m²/kW evaporator fouling factor
 Rated conditions are for compressors running at nominal frequency.
 Boost conditions are for compressors running at maximum frequency.
 10% glycol is recommend for shaded area conditions

7 Standard rating

7 - 1 Cooling capacity tables

EWYD-BZSS

Size	ELWT (°C)	Condenser Inlet Air Temperature (°C)															
		20				25				30				35			
		Rated		Boost		Rated		Boost		Rated		Boost		Rated		Boost	
		Cc (kW)	Pi (kW)	Cc (kW)	Pi (kW)	Cc (kW)	Pi (kW)	Cc (kW)	Pi (kW)	Cc (kW)	Pi (kW)	Cc (kW)	Pi (kW)	Cc (kW)	Pi (kW)	Cc (kW)	Pi (kW)
580	4	606	161	802	267	583	176	734	264	559	191	678	268	533	208	616	266
	5	624	163	817	266	601	178	755	268	576	193	692	267	549	210	628	265
	6	642	166	833	265	618	180	769	266	593	196	705	266	566	213	647	268
	7	660	168	848	265	636	182	784	265	611	198	718	264	583	215	660	267
	8	679	170	864	264	654	185	798	264	628	200	738	268	601	218	672	265
	9	698	172	886	268	673	187	819	268	646	203	752	266	618	220	691	268
	10	717	174	902	267	691	189	834	266	664	205	765	265	636	223	703	266
	11	736	177	917	266	710	192	848	265	683	208	785	268	654	225	715	264
	12	755	179	933	265	729	194	862	264	701	210	799	266	672	228	735	268
	13	775	182	948	264	749	197	884	267	720	213	812	265	690	231	747	266
	14	795	184	971	268	768	199	898	266	739	216	832	268	709	233	759	264
	15	815	186	986	267	788	202	912	265	759	218	845	266	728	236	778	267

NOTES

Cc (cooling capacity) - Pi (unit power input) – ELWT (evaporator leaving water temperature – Δt 5°C).

Data are referred to 0,0176 m² °C/kW evaporator fouling factor

Rated conditions are for compressors running at nominal frequency.

Boost conditions are for compressors running at maximum frequency.

10% glycol is recommend for shaded area conditions

7 Standard rating

7 - 1 Cooling capacity tables

EWYD-BZSS

Size	ELWT (°C)	Condenser Inlet Air Temperature (°C)											
		36				40				45			
		Rated		Boost		Rated		Boost		Rated		Boost	
		Cc (kW)	Pi (kW)	Cc (kW)	Pi (kW)	Cc (kW)	Pi (kW)	Cc (kW)	Pi (kW)	Cc (kW)	Pi (kW)	Cc (kW)	Pi (kW)
580	4	604	266	604	266	554	264	554	264	481	251	481	251
	5	617	265	617	265	571	267	571	267	490	248	490	248
	6	634	268	634	268	583	265	583	265	506	251	506	251
	7	648	267	648	267	601	268	601	268	516	249	516	249
	8	660	265	660	265	612	266	612	266	532	251	532	251
	9	678	267	678	267	623	264	623	264	542	249	542	249
	10	691	266	691	266	641	267	641	267	558	251	558	251
	11	703	265	703	265	652	265	652	265	568	249	568	249
	12	722	268	722	268	671	268	671	268	584	251	584	251
	13	734	266	734	266	682	266	682	266	593	249	593	249
	14	745	264	745	264	693	263	693	263	610	251	610	251
	15	765	267	765	267	711	266	711	266	619	248	619	248

NOTES

Cc (cooling capacity) - Pi (unit power input) – ELWT (evaporator leaving water temperature – Δt 5°C).
 Data are referred to 0,0176 m² °C/kW evaporator fouling factor
 Rated conditions are for compressors running at nominal frequency.
 Boost conditions are for compressors running at maximum frequency.
 10% glycol is recommend for shaded area conditions

7 Standard rating

7 - 1 Cooling capacity tables

EWYD-BZSL

Size		ELWT (°C)		Condenser Inlet Air Temperature (°C)															
				20				25				30				35			
				Rated		Boost		Rated		Boost		Rated		Boost		Rated		Boost	
Cc (kW)	Pi (kW)	Cc (kW)	Pi (kW)	Cc (kW)	Pi (kW)	Cc (kW)	Pi (kW)	Cc (kW)	Pi (kW)	Cc (kW)	Pi (kW)	Cc (kW)	Pi (kW)	Cc (kW)	Pi (kW)				
250	4	258	65,5	348	116	248	71,5	333	127	237	78,1	306	127	226	85,3	281	129		
	5	266	66,4	358	118	256	72,5	340	127	245	79,2	312	127	233	86,3	287	128		
	6	274	67,4	367	120	263	73,5	347	127	252	80,2	321	128	240	87,4	293	128		
	7	282	68,4	377	122	271	74,6	354	126	260	81,3	328	128	248	88,5	299	127		
	8	290	69,4	387	124	279	75,6	363	128	267	82,4	334	128	255	89,7	305	126		
	9	298	70,4	397	125	287	76,7	370	128	275	83,5	341	127	263	90,8	314	128		
	10	306	71,5	407	127	295	77,8	377	127	283	84,6	347	127	270	92,0	320	128		
	11	314	72,5	414	127	303	78,9	384	127	291	85,8	356	129	278	93,2	326	127		
	12	323	73,6	422	127	311	80,0	391	127	299	86,9	363	128	286	94,4	332	126		
	13	331	74,7	429	127	320	81,2	400	129	307	88,1	369	127	294	95,7	340	128		
	14	340	75,8	436	126	328	82,3	407	128	315	89,4	375	127	302	96,9	346	127		
	15	349	77,0	446	128	337	83,5	414	128	324	90,6	385	129	310	98,2	352	126		
	270	4	278	72,6	361	121	267	79,4	340	128	255	86,8	312	127	243	94,8	285	128	
		5	286	73,7	371	123	275	80,5	347	127	263	87,9	318	127	250	96,0	291	128	
		6	294	74,8	379	124	283	81,6	354	127	271	89,1	327	129	258	97,2	297	127	
7		303	75,9	388	125	291	82,8	360	127	279	90,3	333	128	266	98,4	305	128		
8		311	77,0	396	125	299	84,0	369	127	287	91,5	339	127	274	100	310	127		
9		320	78,1	405	126	308	85,1	377	128	295	92,8	346	127	282	101	318	127		
10		328	79,3	413	127	316	86,4	384	127	303	94,0	354	127	290	102	325	128		
11		337	80,5	422	128	325	87,6	390	127	312	95,3	361	128	298	104	331	127		
12		346	81,7	430	127	334	88,9	397	126	320	96,6	367	127	306	105	336	126		
13		355	82,9	437	127	342	90,1	407	128	329	98,0	375	128	314	106	345	128		
14		364	84,2	444	127	351	91,4	413	128	338	99,3	381	127	323	108	351	127		
15		373	85,4	452	127	360	92,8	420	127	346	101	389	128	331	109	358	128		
290		4	305	80,8	382	126	293	88,3	354	128	280	96,4	322	127	266	105	294	127	
		5	314	82,0	393	128	301	89,6	361	128	288	97,8	332	128	274	107	300	126	
		6	323	83,2	400	128	310	90,9	368	127	297	99,1	338	128	282	108	309	128	
	7	332	84,5	407	128	319	92,2	374	126	305	100	345	127	291	109	315	127		
	8	341	85,8	415	127	328	93,5	385	128	314	102	351	126	299	111	320	126		
	9	351	87,1	422	127	337	94,9	391	128	323	103	360	128	308	112	330	128		
	10	360	88,5	429	126	347	96,3	398	127	332	105	367	127	317	114	335	127		
	11	370	89,8	440	128	356	97,7	405	126	341	106	373	127	326	115	341	126		
	12	380	91,2	447	128	365	99,2	415	128	351	108	383	128	335	117	350	128		
	13	389	92,6	454	127	375	101	422	128	360	109	389	128	344	119	356	127		
	14	400	94,1	462	127	385	102	428	127	369	111	395	127	353	120	361	126		
	15	410	95,6	469	126	395	104	435	126	379	112	405	129	362	122	371	128		
	320	4	329	83,7	436	144	317	91,6	409	150	303	100	375	150	289	109	343	150	
		5	339	84,9	448	146	326	92,8	417	150	313	101	383	149	298	111	350	150	
		6	349	86,0	459	147	336	94,0	427	150	322	103	392	150	307	112	357	149	
7		359	87,2	469	148	345	95,2	435	150	331	104	400	149	316	113	366	150		
8		369	88,5	479	149	355	96,5	444	149	341	105	408	149	326	115	375	150		
9		379	89,7	490	150	365	97,8	452	149	351	107	419	151	335	116	382	149		
10		389	91,0	498	150	375	99,1	463	151	361	108	426	150	345	117	391	149		
11		400	92,2	509	150	386	100	472	150	371	109	434	149	355	119	399	150		
12		410	93,6	518	150	396	102	480	149	381	111	443	149	365	120	406	149		
13		421	94,9	526	149	406	103	487	149	391	112	452	150	374	122	415	149		
14		432	96,2	535	149	417	105	499	151	401	114	460	149	385	123	424	150		
15		443	97,6	545	150	428	106	507	150	412	115	469	150	395	125	431	149		

NOTES

Cc (cooling capacity) - Pi (unit power input) – ELWT (evaporator leaving water temperature – Δt 5°C).
 Data are referred to 0,0176 m² °C/kW evaporator fouling factor
 Rated conditions are for compressors running at nominal frequency.
 Boost conditions are for compressors running at maximum frequency.
 10% glycol is recommend for shaded area conditions

7 Standard rating

7 - 1 Cooling capacity tables

EWYD-BZSL

Size	ELWT (°C)	Condenser Inlet Air Temperature (°C)												
		36				40				45				
		Rated		Boost		Rated		Boost		Rated		Boost		
		Cc (kW)	Pi (kW)	Cc (kW)	Pi (kW)	Cc (kW)	Pi (kW)	Cc (kW)	Pi (kW)	Cc (kW)	Pi (kW)	Cc (kW)	Pi (kW)	
250	4	274	127	274	127	245	118	245	118	218	117	218	117	
	5	280	126	280	126	250	118	250	118	225	118	225	118	
	6	286	125	286	125	255	117	255	117	230	117	230	117	
	7	291	125	291	125	260	116	260	116	235	116	235	116	
	8	298	125	298	125	268	118	268	118	242	118	242	118	
	9	306	126	306	126	273	117	273	117	247	117	247	117	
	10	312	126	312	126	281	118	281	118	254	118	254	118	
	11	318	125	318	125	286	117	286	117	259	117	259	117	
	12	323	124	323	124	291	116	291	116	264	116	264	116	
	13	332	126	332	126	300	118	300	118	271	117	271	117	
	14	338	125	338	125	304	117	304	117	276	116	276	116	
	15	343	124	343	124	309	116	309	116	283	118	283	118	
	270	4	278	126	278	126	246	117	246	117	220	117	220	117
		5	284	126	284	126	253	118	253	118	227	118	227	118
		6	289	125	289	125	258	117	258	117	232	117	232	117
7		297	126	297	126	265	117	265	117	238	117	238	117	
8		303	125	303	125	271	117	271	117	243	117	243	117	
9		310	125	310	125	277	118	277	118	250	117	250	117	
10		317	126	317	126	284	118	284	118	255	117	255	117	
11		322	125	322	125	289	117	289	117	262	117	262	117	
12		328	124	328	124	295	117	295	117	266	116	266	116	
13		337	126	337	126	301	117	301	117	274	117	274	117	
14		342	125	342	125	308	117	308	117	278	116	278	116	
15		349	125	349	125	313	116	313	116	286	118	286	118	
290		4	286	125	286	125	254	117	254	117	226	117	226	117
		5	292	124	292	124	259	116	259	116	230	116	230	116
		6	300	126	300	126	267	118	267	118	238	117	238	117
	7	306	125	306	125	272	117	272	117	242	116	242	116	
	8	312	125	312	125	280	118	280	118	250	117	250	117	
	9	321	126	321	126	285	117	285	117	254	116	254	116	
	10	327	125	327	125	293	118	293	118	262	117	262	117	
	11	332	124	332	124	298	117	298	117	266	116	266	116	
	12	341	126	341	126	302	116	302	116	274	117	274	117	
	13	347	125	347	125	311	117	311	117	278	116	278	116	
	14	352	124	352	124	315	116	315	116	286	117	286	117	
	15	361	126	361	126	324	118	324	118	290	116	290	116	
	320	4	334	148	334	148	299	140	299	140	268	141	268	141
		5	341	147	341	147	305	139	305	139	274	139	274	139
		6	349	147	349	147	314	140	314	140	281	139	281	139
7		357	147	357	147	320	139	320	139	288	140	288	140	
8		366	148	366	148	328	139	328	139	296	140	296	140	
9		373	147	373	147	336	140	336	140	303	140	303	140	
10		381	147	381	147	342	139	342	139	310	140	310	140	
11		389	148	389	148	350	139	350	139	316	138	316	138	
12		396	147	396	147	357	139	357	139	325	140	325	140	
13		405	147	405	147	365	139	365	139	330	138	330	138	
14		414	148	414	148	373	139	373	139	339	140	339	140	
15		421	147	421	147	381	139	381	139	345	139	345	139	

NOTES

Cc (cooling capacity) - Pi (unit power input) – ELWT (evaporator leaving water temperature – Δt 5°C).
 Data are referred to 0,0176 m² °C/kW evaporator fouling factor
 Rated conditions are for compressors running at nominal frequency.
 Boost conditions are for compressors running at maximum frequency.
 10% glycol is recommend for shaded area conditions

7 Standard rating

7 - 1 Cooling capacity tables

EWYD-BZSL		ELWT (°C)		Condenser Inlet Air Temperature (°C)															
				20				25				30				35			
				Rated		Boost		Rated		Boost		Rated		Boost		Rated		Boost	
Size	Cc (kW)	Pi (kW)	Cc (kW)	Pi (kW)	Cc (kW)	Pi (kW)	Cc (kW)	Pi (kW)	Cc (kW)	Pi (kW)	Cc (kW)	Pi (kW)	Cc (kW)	Pi (kW)	Cc (kW)	Pi (kW)			
330	4	345	89,9	460	159	332	98,4	437	171	318	108	402	171	303	118	367	170		
	5	356	91,2	472	162	342	100	446	171	328	109	411	170	312	119	375	170		
	6	366	92,4	484	164	352	101	455	170	337	110	419	170	322	120	383	169		
	7	376	93,7	497	166	362	102	464	170	347	112	427	169	331	122	394	171		
	8	386	95,1	510	169	372	104	473	169	357	113	435	169	341	123	401	170		
	9	397	96,4	522	172	383	105	481	169	367	115	447	171	351	125	409	169		
	10	408	97,8	532	171	393	107	494	171	377	116	455	170	361	126	417	168		
	11	418	99,2	541	171	404	108	502	171	388	118	463	170	371	128	428	171		
	12	429	101	550	170	414	110	511	170	398	119	471	169	381	130	435	170		
	13	440	102	560	170	425	111	520	169	409	121	483	171	391	131	443	169		
	14	452	104	569	169	436	113	532	172	419	122	491	170	402	133	454	171		
	15	463	105	582	172	447	114	541	171	430	124	499	169	412	135	461	170		
	360	4	371	97,6	485	167	357	107	452	171	341	117	414	170	325	128	378	170	
		5	382	99,0	496	168	367	108	461	170	352	118	423	169	335	129	386	169	
		6	393	100	507	169	378	110	470	170	362	120	433	170	345	131	395	170	
7		404	102	518	170	389	111	479	169	373	121	441	169	355	132	405	171		
8		415	103	528	169	400	113	490	170	383	123	451	170	366	134	413	170		
9		427	105	539	170	411	114	500	171	394	125	459	169	376	136	422	170		
10		438	106	551	171	422	116	509	170	405	126	470	170	387	138	432	171		
11		450	108	560	171	434	118	518	170	416	128	478	169	398	139	439	170		
12		462	110	570	170	445	119	529	170	427	130	488	170	409	141	447	169		
13		474	111	579	169	457	121	538	170	439	132	498	171	420	143	459	171		
14		486	113	588	169	469	123	549	170	450	133	506	170	431	145	466	170		
15		498	115	600	170	480	125	557	170	462	135	514	168	442	147	473	168		
370		4	389	104	497	171	374	114	458	171	358	125	419	170	340	137	383	171	
		5	401	106	506	171	385	116	467	170	368	127	427	169	351	138	391	170	
		6	412	107	516	170	396	117	475	170	379	128	439	171	361	140	398	169	
	7	423	109	525	170	407	119	484	169	390	130	447	170	372	142	410	171		
	8	435	111	535	169	419	121	497	171	401	132	455	169	383	144	417	170		
	9	447	112	544	168	430	122	506	171	413	133	463	168	394	145	425	169		
	10	459	114	558	171	442	124	515	170	424	135	476	171	405	147	437	171		
	11	471	115	567	170	454	126	523	169	435	137	484	170	416	149	444	170		
	12	483	117	576	170	466	128	536	171	447	139	492	169	427	151	451	169		
	13	495	119	585	169	478	129	545	170	459	141	504	171	439	153	463	171		
	14	508	121	595	168	490	131	553	169	471	143	512	170	450	155	470	169		
	15	520	123	608	171	502	133	562	168	483	145	520	169	462	157	477	168		
	400	4	420	110	535	174	404	120	502	183	387	131	465	187	369	144	424	186	
		5	432	111	547	175	416	122	514	184	399	133	477	188	380	145	434	187	
		6	445	113	559	176	428	123	525	185	411	135	486	187	392	147	445	188	
7		457	114	571	177	440	125	539	187	422	136	495	186	403	149	453	187		
8		470	116	586	180	453	127	549	187	435	138	507	187	415	151	462	185		
9		482	118	598	181	465	128	559	186	447	140	516	186	427	152	474	188		
10		495	119	611	182	478	130	573	188	459	142	527	187	439	154	483	186		
11		508	121	623	183	491	132	583	187	472	143	539	188	451	156	494	187		
12		522	122	638	185	504	133	593	186	484	145	548	186	464	158	504	187		
13		535	124	651	186	517	135	605	187	497	147	556	185	476	160	515	188		
14		549	126	663	187	530	137	617	188	510	149	570	188	486	160	523	187		
15		562	128	674	186	543	139	627	187	523	151	579	186	495	160	531	185		

NOTES

Cc (cooling capacity) - Pi (unit power input) - ELWT (evaporator leaving water temperature - Δt 5°C).
 Data are referred to 0,0176 m² °C/kW evaporator fouling factor
 Rated conditions are for compressors running at nominal frequency.
 Boost conditions are for compressors running at maximum frequency.
 10% glycol is recommend for shaded area conditions

7 Standard rating

7 - 1 Cooling capacity tables

EWYD-BZSL

Size	ELWT (°C)	Condenser Inlet Air Temperature (°C)												
		36				40				45				
		Rated		Boost		Rated		Boost		Rated		Boost		
		Cc (kW)	Pi (kW)	Cc (kW)	Pi (kW)	Cc (kW)	Pi (kW)	Cc (kW)	Pi (kW)	Cc (kW)	Pi (kW)	Cc (kW)	Pi (kW)	
330	4	358	168	358	168	323	160	323	160	291	161	291	161	
	5	366	167	366	167	330	159	330	159	298	160	298	160	
	6	374	167	374	167	340	161	340	161	304	159	304	159	
	7	384	169	384	169	347	160	347	160	313	160	313	160	
	8	392	168	392	168	354	159	354	159	320	159	320	159	
	9	400	168	400	168	364	161	364	161	329	161	329	161	
	10	407	167	407	167	371	159	371	159	336	160	336	160	
	11	418	168	418	168	377	158	377	158	342	158	342	158	
	12	426	168	426	168	388	160	388	160	351	160	351	160	
	13	433	167	433	167	394	159	394	159	357	158	357	158	
	14	444	169	444	169	405	161	405	161	367	160	367	160	
	15	451	168	451	168	411	159	411	159	373	159	373	159	
	360	4	368	168	368	168	330	159	330	159	296	159	296	159
		5	377	168	377	168	340	161	340	161	306	161	306	161
		6	386	168	386	168	347	159	347	159	312	160	312	160
7		395	168	395	168	354	158	354	158	320	160	320	160	
8		403	168	403	168	365	160	365	160	328	160	328	160	
9		412	168	412	168	371	159	371	159	334	158	334	158	
10		422	169	422	169	382	161	382	161	344	160	344	160	
11		429	168	429	168	388	159	388	159	350	159	350	159	
12		437	167	437	167	397	160	397	160	358	159	358	159	
13		448	169	448	169	406	160	406	160	366	159	366	159	
14		456	168	456	168	415	160	415	160	374	159	374	159	
15		463	167	463	167	423	160	423	160	385	161	385	161	
370		4	373	169	373	169	333	159	333	159	298	159	298	159
		5	381	168	381	168	343	161	343	161	308	161	308	161
		6	389	167	389	167	350	159	350	159	314	159	314	159
	7	399	169	399	169	357	158	357	158	324	161	324	161	
	8	407	168	407	168	367	160	367	160	330	160	330	160	
	9	415	167	415	167	374	158	374	158	335	158	335	158	
	10	426	169	426	169	384	160	384	160	345	160	345	160	
	11	433	168	433	168	391	159	391	159	351	158	351	158	
	12	441	167	441	167	402	161	402	161	361	160	361	160	
	13	452	168	452	168	408	159	408	159	367	158	367	158	
	14	460	168	460	168	419	161	419	161	377	159	377	159	
	15	467	166	467	166	425	159	425	159	388	161	388	161	
	400	4	416	187	416	187	385	188	385	188	343	186	343	186
		5	426	187	426	187	393	187	393	187	352	186	352	186
		6	436	187	436	187	401	186	401	186	361	187	361	187
7		445	187	445	187	413	188	413	188	371	187	371	187	
8		453	185	453	185	421	186	421	186	378	185	378	185	
9		466	187	466	187	431	187	431	187	389	187	389	187	
10		474	187	474	187	441	187	441	187	399	187	399	187	
11		485	187	485	187	451	187	451	187	408	187	408	187	
12		495	187	495	187	458	186	458	186	418	188	418	188	
13		506	188	506	188	471	188	471	188	424	186	424	186	
14		514	187	514	187	478	186	478	186	436	188	436	188	
15		523	185	523	185	489	187	489	187	443	186	443	186	

NOTES

Cc (cooling capacity) - Pi (unit power input) – ELWT (evaporator leaving water temperature – Δt 5°C).
 Data are referred to 0,0176 m² °C/kW evaporator fouling factor
 Rated conditions are for compressors running at nominal frequency.
 Boost conditions are for compressors running at maximum frequency.
 10% glycol is recommend for shaded area conditions

7 Standard rating

7 - 1 Cooling capacity tables

EWYD-BZSL		Condenser Inlet Air Temperature (°C)																
		20				25				30				35				
		Rated		Boost		Rated		Boost		Rated		Boost		Rated		Boost		
Size	ELWT (°C)	Cc (kW)	Pi (kW)	Cc (kW)	Pi (kW)	Cc (kW)	Pi (kW)	Cc (kW)	Pi (kW)	Cc (kW)	Pi (kW)	Cc (kW)	Pi (kW)	Cc (kW)	Pi (kW)	Cc (kW)	Pi (kW)	
430	4	444	118	578	203	427	130	534	203	409	142	490	203	389	155	446	201	
	5	457	120	589	203	439	131	545	203	421	144	500	202	401	157	459	204	
	6	469	122	600	202	452	133	555	202	433	145	510	201	413	159	468	203	
	7	482	123	611	201	465	135	566	201	445	147	524	204	425	161	477	202	
	8	496	125	623	200	477	137	580	204	458	149	533	203	437	163	486	200	
	9	509	127	638	203	490	139	591	203	471	151	543	201	450	165	500	203	
	10	522	129	649	203	504	140	601	202	484	153	552	200	462	167	508	201	
	11	536	130	660	202	517	142	611	201	497	155	567	203	475	169	522	204	
	12	550	132	671	201	531	144	626	204	510	157	576	202	488	171	531	203	
	13	564	134	682	200	544	146	637	203	523	159	586	200	501	173	540	201	
	14	578	136	698	203	558	148	647	202	537	161	600	203	514	175	553	204	
	15	592	138	709	203	572	150	657	201	550	163	610	202	527	178	562	202	
	450	4	465	116	617	194	447	126	564	192	429	138	517	192	409	151	474	195
		5	478	117	629	194	461	128	580	195	442	140	532	195	422	153	483	193
		6	492	119	641	193	474	130	592	194	455	142	542	194	435	154	493	192
7		506	120	653	193	488	131	603	193	469	143	553	193	448	156	507	195	
8		521	122	670	195	502	133	614	192	482	145	568	195	461	158	517	193	
9		535	124	682	195	516	135	630	195	496	147	578	194	475	160	526	192	
10		550	125	694	194	531	137	641	194	510	149	589	193	488	162	541	194	
11		565	127	706	193	545	138	652	193	524	151	604	195	502	164	550	193	
12		580	129	718	193	560	140	663	192	539	152	614	194	516	166	565	195	
13		595	131	729	192	575	142	680	195	553	154	624	193	530	168	574	194	
14		610	133	747	195	590	144	691	194	568	156	640	195	545	170	584	192	
15		626	134	759	194	605	146	702	193	583	158	650	194	559	172	599	195	
490		4	513	129	686	224	494	141	646	236	473	154	592	236	450	168	539	235
		5	529	131	703	226	508	143	659	236	487	156	605	235	464	170	551	234
		6	544	133	720	229	524	145	672	235	502	158	617	234	479	172	563	234
	7	560	135	737	231	539	147	685	234	517	160	629	233	493	174	578	236	
	8	575	136	755	233	554	149	698	234	532	162	643	233	508	176	589	234	
	9	591	138	774	237	570	151	713	234	547	164	658	236	523	179	602	234	
	10	608	140	788	236	586	153	729	236	563	166	670	234	538	181	613	233	
	11	624	142	802	235	602	155	742	235	578	169	684	234	553	183	628	235	
	12	641	144	815	235	618	157	755	234	594	171	696	233	569	186	641	234	
	13	658	147	829	234	635	159	770	234	610	173	712	235	584	188	652	233	
	14	675	149	843	233	651	162	782	233	626	175	726	235	600	190	669	236	
	15	692	151	859	234	668	164	799	235	643	178	738	234	616	193	680	234	
	510	4	531	135	711	239	510	148	676	257	489	161	622	257	465	176	567	255
		5	546	137	731	242	526	149	690	256	504	163	635	256	480	178	579	254
		6	562	139	750	246	541	151	704	256	519	165	648	255	495	180	591	253
7		578	141	770	250	557	154	718	255	534	167	660	254	510	183	608	257	
8		594	143	789	253	573	156	732	254	549	170	673	253	525	185	620	255	
9		611	145	810	257	589	158	745	253	565	172	691	257	540	187	632	254	
10		628	147	824	257	605	160	764	257	581	174	704	256	555	189	644	252	
11		644	149	839	256	621	162	778	256	597	176	717	254	571	192	661	256	
12		662	151	853	255	638	164	791	255	613	179	729	253	587	194	673	254	
13		679	153	868	255	655	167	805	254	630	181	748	256	603	197	684	253	
14		696	156	882	254	672	169	818	253	647	184	760	255	619	199	702	256	
15		714	158	897	253	690	171	838	256	663	186	773	254	636	202	714	254	

NOTES

Cc (cooling capacity) - Pi (unit power input) - ELWT (evaporator leaving water temperature - Δt 5°C).
 Data are referred to 0,0176 m² °C/kW evaporator fouling factor
 Rated conditions are for compressors running at nominal frequency.
 Boost conditions are for compressors running at maximum frequency.
 10% glycol is recommend for shaded area conditions

7 Standard rating

7 - 1 Cooling capacity tables

EWYD-BZSL

Size	ELWT (°C)	Condenser Inlet Air Temperature (°C)												
		36				40				45				
		Rated		Boost		Rated		Boost		Rated		Boost		
		Cc (kW)	Pi (kW)	Cc (kW)	Pi (kW)	Cc (kW)	Pi (kW)	Cc (kW)	Pi (kW)	Cc (kW)	Pi (kW)	Cc (kW)	Pi (kW)	
430	4	435	199	435	199	394	192	394	192	353	193	353	193	
	5	448	201	448	201	402	190	402	190	361	191	361	191	
	6	457	201	457	201	414	192	414	192	372	193	372	193	
	7	466	199	466	199	422	191	422	191	380	191	380	191	
	8	476	199	476	199	434	193	434	193	391	193	391	193	
	9	488	201	488	201	442	191	442	191	399	191	399	191	
	10	498	200	498	200	455	194	455	194	410	194	410	194	
	11	510	202	510	202	462	192	462	192	417	191	417	191	
	12	519	200	519	200	470	190	470	190	429	194	429	194	
	13	528	199	528	199	483	192	483	192	436	192	436	192	
	14	541	201	541	201	490	191	490	191	448	194	448	194	
	15	550	200	550	200	503	193	503	193	455	191	455	191	
	450	4	460	191	460	191	407	178	407	178	365	179	365	179
		5	470	190	470	190	415	177	415	177	372	178	372	178
		6	480	190	480	190	428	179	428	179	384	179	384	179
7		493	191	493	191	436	177	436	177	391	178	391	178	
8		503	190	503	190	450	179	450	179	404	179	404	179	
9		512	189	512	189	457	178	457	178	411	178	411	178	
10		527	191	527	191	471	180	471	180	424	179	424	179	
11		536	190	536	190	478	178	478	178	430	177	430	177	
12		551	192	551	192	492	180	492	180	443	179	443	179	
13		560	191	560	191	500	178	500	178	450	177	450	177	
14		568	189	568	189	507	176	507	176	463	179	463	179	
15		583	192	583	192	521	179	521	179	469	177	469	177	
490		4	530	236	530	236	495	239	495	239	446	241	446	241
		5	541	234	541	234	505	238	505	238	456	240	456	240
		6	555	235	555	235	521	241	521	241	466	238	466	238
	7	569	236	569	236	531	239	531	239	481	241	481	241	
	8	580	235	580	235	542	238	542	238	490	239	490	239	
	9	593	236	593	236	558	241	558	241	504	240	504	240	
	10	604	234	604	234	568	239	568	239	515	240	515	240	
	11	619	236	619	236	583	241	583	241	528	241	528	241	
	12	631	235	631	235	593	239	593	239	538	239	538	239	
	13	643	234	643	234	605	239	605	239	549	238	549	238	
	14	659	237	659	237	620	240	620	240	563	240	563	240	
	15	670	235	670	235	630	238	630	238	572	237	572	237	
	510	4	553	252	553	252	498	239	498	239	448	241	448	241
		5	565	251	565	251	509	238	509	238	458	239	458	239
		6	578	251	578	251	524	241	524	241	468	237	468	237
7		593	253	593	253	535	239	535	239	483	240	483	240	
8		605	252	605	252	545	238	545	238	492	238	492	238	
9		618	251	618	251	561	241	561	241	507	241	507	241	
10		629	250	629	250	572	239	572	239	517	239	517	239	
11		646	253	646	253	588	242	588	242	532	242	532	242	
12		658	252	658	252	598	240	598	240	542	239	542	239	
13		669	250	669	250	608	238	608	238	551	237	551	237	
14		687	253	687	253	624	241	624	241	566	240	566	240	
15		698	251	698	251	634	239	634	239	575	237	575	237	

NOTES

Cc (cooling capacity) - Pi (unit power input) – ELWT (evaporator leaving water temperature – Δt 5°C).
 Data are referred to 0,0176 m² °C/kW evaporator fouling factor
 Rated conditions are for compressors running at nominal frequency.
 Boost conditions are for compressors running at maximum frequency.
 10% glycol is recommend for shaded area conditions

7 Standard rating

7 - 1 Cooling capacity tables

EWYD-BZSL

Size	ELWT (°C)	Condenser Inlet Air Temperature (°C)															
		20				25				30				35			
		Rated		Boost		Rated		Boost		Rated		Boost		Rated		Boost	
		Cc (kW)	Pi (kW)	Cc (kW)	Pi (kW)	Cc (kW)	Pi (kW)	Cc (kW)	Pi (kW)	Cc (kW)	Pi (kW)	Cc (kW)	Pi (kW)	Cc (kW)	Pi (kW)	Cc (kW)	Pi (kW)
570	4	595	158	755	255	571	173	695	254	546	189	640	257	519	206	579	254
	5	612	160	770	255	588	175	708	253	562	191	653	256	535	209	597	257
	6	629	162	784	254	605	178	728	257	579	194	665	254	551	211	608	256
	7	647	165	799	253	622	180	741	256	596	196	678	253	567	214	620	254
	8	665	167	819	257	640	183	755	255	613	199	696	257	584	217	631	252
	9	683	170	834	256	657	185	768	254	630	202	709	255	601	220	649	256
	10	701	172	848	255	675	188	781	252	647	205	721	254	618	223	661	254
	11	720	175	862	254	693	191	801	256	665	207	740	257	635	226	679	257
	12	739	178	877	253	712	193	815	255	683	210	752	256	653	229	690	255
	13	758	180	898	257	730	196	828	254	701	213	764	254	670	232	701	253
	14	777	183	912	256	749	199	840	252	720	216	776	252	688	235	719	257
	15	797	186	926	255	768	202	861	256	738	219	796	256	706	238	730	255

NOTES

Cc (cooling capacity) - Pi (unit power input) – ELWT (evaporator leaving water temperature – Δt 5°C).

Data are referred to 0,0176 m² °C/kW evaporator fouling factor

Rated conditions are for compressors running at nominal frequency.

Boost conditions are for compressors running at maximum frequency.

10% glycol is recommend for shaded area conditions

7 Standard rating

7 - 1 Cooling capacity tables

EWYD-BZSL

Size	ELWT (°C)	Condenser Inlet Air Temperature (°C)											
		36				40				45			
		Rated		Boost		Rated		Boost		Rated		Boost	
		Cc (kW)	Pi (kW)	Cc (kW)	Pi (kW)	Cc (kW)	Pi (kW)	Cc (kW)	Pi (kW)	Cc (kW)	Pi (kW)	Cc (kW)	Pi (kW)
570	4	565	251	565	251	508	240	508	240	453	240	453	240
	5	581	253	581	253	518	238	518	238	463	238	463	238
	6	594	253	594	253	534	241	534	241	478	240	478	240
	7	605	251	605	251	544	238	544	238	487	238	487	238
	8	617	250	617	250	560	241	560	241	502	241	502	241
	9	633	252	633	252	570	239	570	239	511	238	511	238
	10	644	250	644	250	579	237	579	237	526	241	526	241
	11	662	254	662	254	596	240	596	240	535	238	535	238
	12	673	252	673	252	605	237	605	237	551	241	551	241
	13	685	251	685	251	622	240	622	240	559	238	559	238
	14	702	253	702	253	632	238	632	238	575	241	575	241
	15	714	252	714	252	649	241	649	241	583	238	583	238

NOTES

Cc (cooling capacity) - Pi (unit power input) – ELWT (evaporator leaving water temperature – Δt 5°C).

Data are referred to 0,0176 m² °C/kW evaporator fouling factor

Rated conditions are for compressors running at nominal frequency.

Boost conditions are for compressors running at maximum frequency.

10% glycol is recommend for shaded area conditions

7 Standard rating

7 - 2 Heating capacity tables

EWYD-BZSS

Size	CLWT (°C)	Condenser Inlet Air Temperature (°C)																			
		-10 (RH 100%)				-5 (RH 100%)				0 (RH 85%)				7 (RH 85%)				12 (RH 85%)			
		Rated		Boost		Rated		Boost		Rated		Boost		Rated		Boost		Rated		Boost	
		Hc (kW)	Pi (kW)	Hc (kW)	Pi (kW)	Hc (kW)	Pi (kW)	Hc (kW)	Pi (kW)	Hc (kW)	Pi (kW)	Hc (kW)	Pi (kW)	Hc (kW)	Pi (kW)	Hc (kW)	Pi (kW)	Hc (kW)	Pi (kW)	Hc (kW)	Pi (kW)
580	35	493	234	493	234	536	214	575	241	575	195	663	248	617	171	810	265	714	179	908	266
	36	496	239	496	239	538	218	578	246	576	199	666	254	617	174	806	267	713	182	904	267
	37	499	245	499	245	539	223	581	251	576	203	669	259	617	177	797	265	713	185	892	265
	38	501	250	501	250	542	228	584	257	577	207	672	265	616	181	793	267	712	189	887	266
	39	504	256	504	256	543	233	586	263	578	211	669	267	616	184	789	268	712	192	881	267
	40	507	261	507	261	545	238	584	265	579	215	661	265	616	187	778	266	712	196	868	264
	41	510	267	510	267	547	243	581	267	580	220	658	267	616	191	774	267	711	199	861	265
	42	503	266	503	266	549	248	574	265	581	224	649	266	616	194	762	265	711	203	854	266
	43	500	268	500	268	551	253	571	267	582	229	645	267	616	198	756	266	710	206	847	267
	44	493	266	493	266	553	258	562	265	583	233	635	265	615	202	750	267	710	210	840	268
	45	490	268	490	268	554	264	559	267	584	238	631	267	615	205	744	268	709	214	824	265
	46	482	266	482	266	550	265	550	265	585	243	626	268	615	209	731	265	708	218	815	265
	47	478	267	478	267	546	267	546	267	586	248	615	266	614	213	724	266	708	221	807	266
	48	470	265	470	265	536	264	536	264	587	252	610	267	614	217	717	267	707	225	798	266
	49	466	266	466	266	531	266	531	266	587	257	605	268	614	221	710	268	707	229	789	267
	50	462	268	462	268	527	267	527	267	588	263	592	265	613	225	694	264	706	233	780	267

NOTES

Hc (heating capacity) - Pi (unit power input) – CLWT (condenser leaving water temperature – Δt 5°C)
 Data are referred to 0,0176 m² °C/kW evaporator fouling factor
 Rated conditions are for compressors running at nominal frequency
 Boost conditions are for compressors running at maximum frequency
 Refer to Operating limit chapter for Integrated Heating Capacity

7 Standard rating

7 - 2 Heating capacity tables

EWYD-BZSL

Size	CLWT (°C)	Condenser Inlet Air Temperature (°C)																			
		-10 (RH 100%)				-5 (RH 100%)				0 (RH 85%)				7 (RH 85%)				12 (RH 85%)			
		Rated		Boost		Rated		Boost		Rated		Boost		Rated		Boost		Rated		Boost	
	Hc (kW)	Pi (kW)	Hc (kW)	Pi (kW)	Hc (kW)	Pi (kW)	Hc (kW)	Pi (kW)	Hc (kW)	Pi (kW)	Hc (kW)	Pi (kW)	Hc (kW)	Pi (kW)	Hc (kW)	Pi (kW)	Hc (kW)	Pi (kW)	Hc (kW)	Pi (kW)	
570	35	493	234	493	234	536	214	575	241	575	195	663	248	617	171	810	265	714	179	908	266
	36	496	239	496	239	538	218	578	246	576	199	666	254	617	174	806	267	713	182	904	267
	37	499	245	499	245	539	223	581	251	576	203	669	259	617	177	797	265	713	185	892	265
	38	501	250	501	250	542	228	584	257	577	207	672	265	616	181	793	267	712	189	887	266
	39	504	256	504	256	543	233	586	263	578	211	669	267	616	184	789	268	712	192	881	267
	40	507	261	507	261	545	238	584	265	579	215	661	265	616	187	778	266	712	196	868	264
	41	510	267	510	267	547	243	581	267	580	220	658	267	616	191	774	267	711	199	861	265
	42	503	266	503	266	549	248	574	265	581	224	649	266	616	194	762	265	711	203	854	266
	43	500	268	500	268	551	253	571	267	582	229	645	267	616	198	756	266	710	206	847	267
	44	493	266	493	266	553	258	562	265	583	233	635	265	615	202	750	267	710	210	840	268
	45	490	268	490	268	554	264	559	267	584	238	631	267	615	205	744	268	709	214	824	265
	46	482	266	482	266	550	265	550	265	585	243	626	268	615	209	731	265	708	218	815	265
	47	478	267	478	267	546	267	546	267	586	248	615	266	614	213	724	266	708	221	807	266
	48	470	265	470	265	536	264	536	264	587	252	610	267	614	217	717	267	707	225	798	266
	49	466	266	466	266	531	266	531	266	587	257	605	268	614	221	710	268	707	229	789	267
	50	462	268	462	268	527	267	527	267	588	263	592	265	613	225	694	264	706	233	780	267

NOTES

Hc (heating capacity) - Pi (unit power input) – CLWT (condenser leaving water temperature – Δt 5°C)
 Data are referred to 0,0176 m²/kW evaporator fouling factor
 Rated conditions are for compressors running at nominal frequency
 Boost conditions are for compressors running at maximum frequency
 Refer to Operating limit chapter for Integrated Heating Capacity

8 Evaporator pressure drop

EWYD-BZSS	250	270	290	320	340	370	380	410	440	460	510	520	580
Cooling Capacity (kW)	254	273	292	324	339	365	382	413	436	457	505	522	583
Water Flow (l/s)	12,12	13,03	13,94	15,46	16,21	17,42	18,25	19,72	20,81	21,83	24,11	24,92	27,87
Pressure Drops (kPa)	37	42	48	53	58	53	57	46	51	61	50	53	65

Water flow and pressure drop referred to nominal condition: evaporator water in/out: 12/7°C – condenser air inlet: 35°C

EWYD-BZSS	250	270	290	320	340	370	380	410	440	460	510	520	580
Heating Capacity (kW)	270	297	324	333	349	379	410	443	463	475	530	558	615
Water Flow (l/s)	12,89	14,18	15,49	15,89	16,66	18,11	19,57	21,15	22,14	22,68	25,33	26,65	29,39
Pressure Drops (kPa)	42	49	58	55	60	57	65	52	57	66	55	60	71

Water flow and pressure drop referred to nominal condition: evaporator water in/out: 12/7°C – condenser air inlet: 35°C

EWYD-BZSL	250	270	290	320	330	360	370	400	430	450	490	510	570
Cooling Capacity (kW)	248	266	291	316	331	355	372	403	425	448	493	510	567
Water Flow (l/s)	11,83	12,70	13,89	15,12	15,83	16,98	17,77	19,28	20,30	21,39	23,56	24,34	27,11
Pressure Drops (kPa)	36	40	48	51	55	50	55	44	48	59	48	51	62

Water flow and pressure drop referred to nominal condition: evaporator water in/out: 12/7°C – condenser air inlet: 35°C

EWYD-BZSL	250	270	290	320	330	360	370	400	430	450	490	510	570
Heating Capacity (kW)	270	297	324	333	349	379	410	443	463	475	530	558	615
Water Flow (l/s)	12,89	14,18	15,49	15,89	16,66	18,11	19,57	21,15	22,14	22,68	25,33	26,65	29,39
Pressure Drops (kPa)	42	49	58	55	60	57	65	52	57	66	55	60	71

Water flow and pressure drop referred to nominal condition: evaporator water in/out: 12/7°C – condenser air inlet: 35°C

Evaporating Pressure Drops

To determinate the pressure drop for different versions or at different working conditions, please refer to the following formula:

$$PD_2 \text{ (kPa)} = PD_1 \text{ (kPa)} \times \left(\frac{Q_2 \text{ (l/s)}}{Q_1 \text{ (l/s)}} \right)^{1.8}$$

where:

- PD₂ Pressure drop to be determinate (kPa)
- PD₁ Pressure drop at nominal condition (kPa)
- Q₂ water flow at new working condition (l/s)
- Q₁ water flow at nominal condition (l/s)

How to use the formula: Example

The unit EWAD650C-SS has been selected for working at the following conditions:

- evaporator water in/out : 11/6°C
- condenser air inlet: 30°C
- The cooling capacity at these working conditions is: 265 kW (Rated conditions)
- The water flow at these working conditions is: 12.68 l/s (Rated conditions)

The unit EWYD250BZSS at nominal working conditions has the following data:

- evaporator water in/out : 12/7°C
- condenser air inlet: 35°C
- The cooling capacity at these working conditions is: 254 kW
- The water flow at these working conditions is: 12.12 l/s
- The pressure drop at these working conditions is: 37 kPa

The pressure drop at the selected working condition will be:

$$PD_2 \text{ (kPa)} = 73 \text{ (kPa)} \times \left(\frac{12.68 \text{ (l/s)}}{12.12 \text{ (l/s)}} \right)^{1.8}$$

$$PD_2 \text{ (kPa)} = 52 \text{ (kPa)}$$

NOTES

If the calculated evaporator water pressure drop is below 10 kPa or above 100 kPa please contact the factory for dedicated evaporator.

9 Options

9 - 1 Partial heat recovery

EWYD-BZ		Evaporator Leaving Temperature 7°C - Δ15°C Condenser Inlet Air 35°C	1Partial Heat Recovery Leaving Water Temperature (°C)			Partial Heat Rrecovery LWT 45°C	
EWYD-BZSS	EWYD-BZSL		45 (Δt=5°C)	50 (Δt=5°C)	55 (Δt=5°C)	Water Flow	Pressure Drops
			Hc (kW)	Hc (kW)	Hc (kW)	l/s	kPa
250	250		74.3	67.8	57.9	3.55	5
270	270	80.9	76.1	65.4	3.87	6	
290	290	88.5	85.2	73.5	4.23	7	
320	320	93.5	88.2	75.7	4.47	8	
340	330	99.4	91.9	78.6	4.75	7	
370	360	106	100	85.7	5.06	8	
380	370	115	109	94.2	5.49	9	
410	400	117	107	96.0	5.60	22	
440	130	125	113	102	5.95	24	
460	450	133	128	110	6.34	15	
510	490	144	135	115	6.86	18	
520	510	149	138	118	7.12	14	
580	570	173	164	141	8.24	18	

OPT_1-2-3-4_Rev.00_1

9 Options

9 - 1 Partial heat recovery

Partial Heat Recovery Pressure Drops

To determinate the pressure drop for different versions or at different working condition, please refer to the following formula:

$$PD_2 \text{ (kPa)} = PD_1 \text{ (kPa)} \times \left(\frac{Q_2 \text{ (l/s)}}{Q_1 \text{ (l/s)}} \right)^{1.80}$$

where:

- PD₂ Pressure drop to be determinate (kPa)
- PD₁ Pressure drop at nominal condition (kPa)
- Q₂ water flow at new working condition (l/s)
- Q₁ water flow at nominal condition (l/s)

How to use the formula: Example

The unit EWYD250BZSS has been selected for working at the following conditions:

Partial heat recovery leaving water temperature 50/55°C

The heating capacity at these working conditions is: 57.9 kW

The water flow at these working conditions is: 2.77 l/s

The unit EWAD650C-SS at nominal working conditions has the following data:

- Partial heat recovery leaving water temperature 40/45°C

- condenser air inlet: 35°C

The heating capacity at these working conditions is: 74.3 kW

The water flow at these working conditions is: 3.55 l/s

The pressure drop at these working conditions is: 5 kPa

The pressure drop at the selected working condition will be:

$$PD_2 \text{ (kPa)} = 5 \text{ (kPa)} \times \left(\frac{2.77 \text{ (l/s)}}{3.55 \text{ (l/s)}} \right)^{1.80}$$

$$PD_2 \text{ (kPa)} = 3 \text{ (kPa)}$$

OPT_1-2-3-4-5_Rev.00_2

9 Options

9 - 2 Water pump kit

Water Pump Kit - Discharge Head

Single Pump (2 poles) - Low Available external static pressure

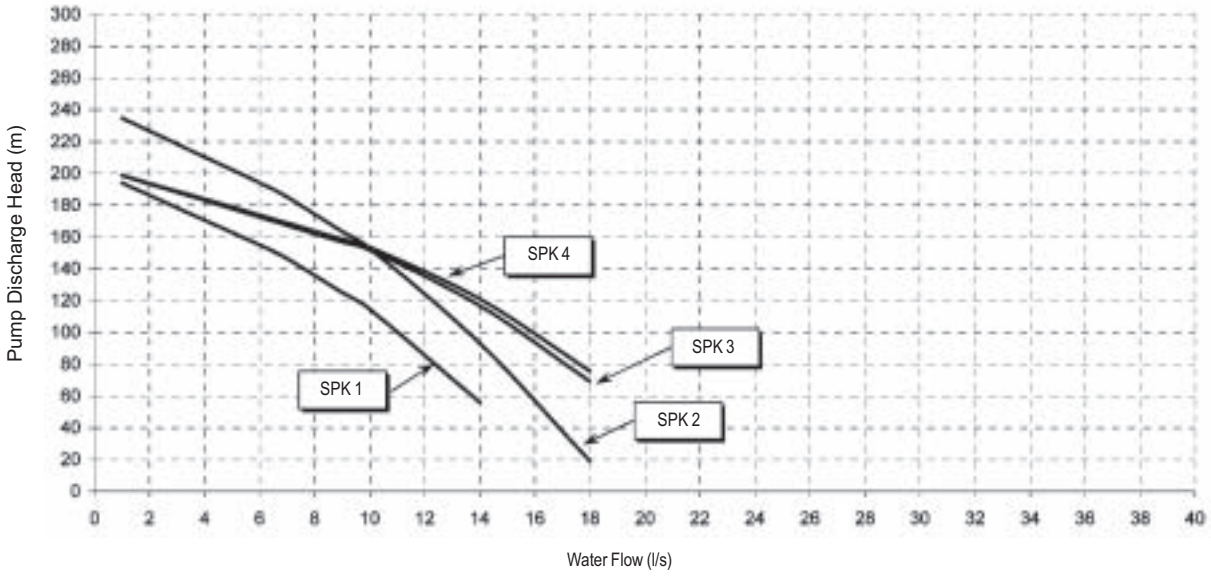

NOTES

- when using mixture of water and glycol please contact the factory as above specification can change

Single Pump (2 poles) - Low Available external static pressure

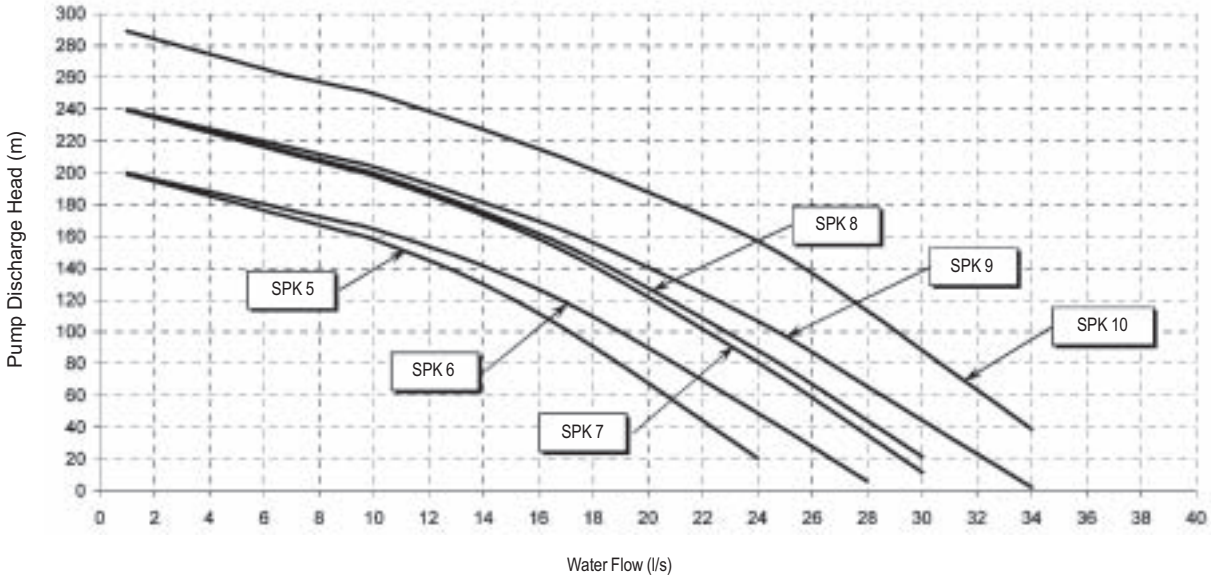

NOTES

- when using mixture of water and glycol please contact the factory as above specification can change

Pump Kit	SPK1	SPK2	SPK3	SPK4		SPK5		SPK6	SPK7	SPK8	SPK9	SPK10	
Size EWYD-BZSS	250	270	290	320	340	370	380	410	440	460	510	520	580
Size EWYD-BZSL	250	270	290	320	330	360	370	400	430	450	490	510	570

9 Options

9 - 2 Water pump kit

Water Pump Kit - Discharge Head

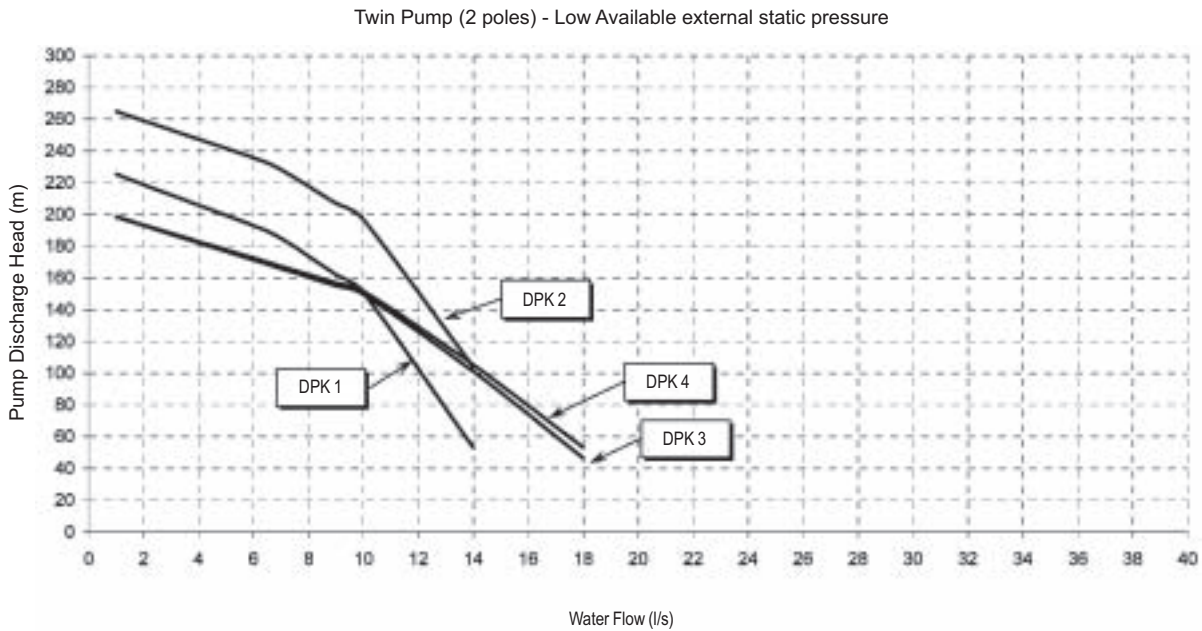

NOTES

- when using mixture of water and glycol please contact the factory as above specification can change

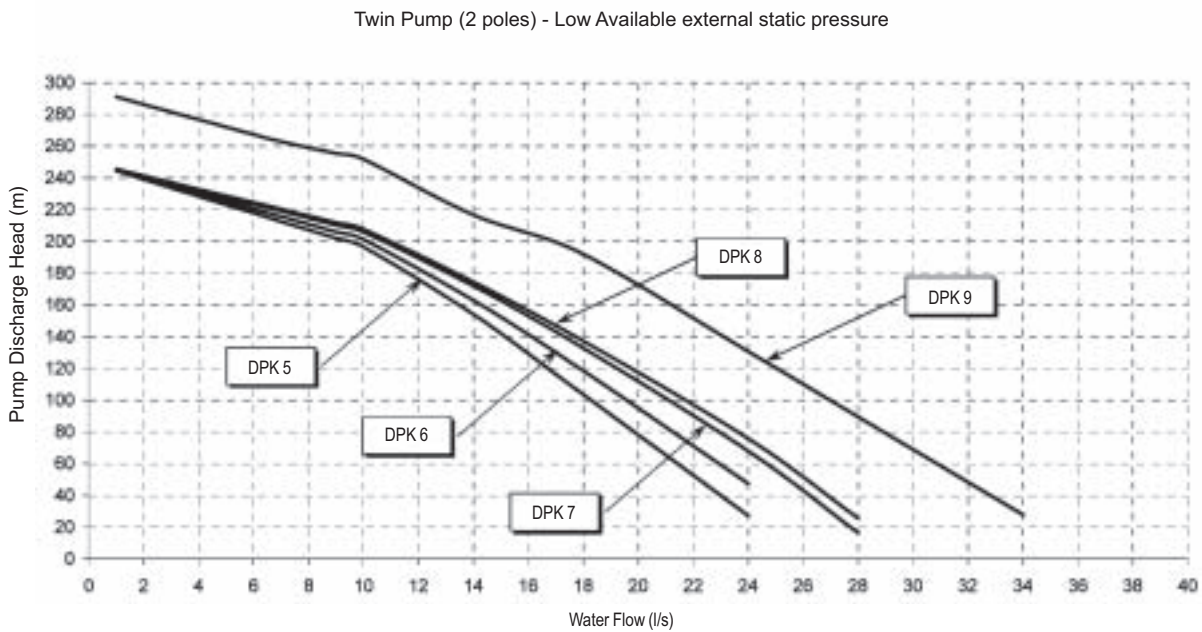

NOTES

- when using mixture of water and glycol please contact the factory as above specification can change

Pump Kit	DPK1	DPK2	DPK3	DPK4	DPK5	DPK6		DPK7		DPK8	DPK9		
Size EWYD-BZSS	250	270	290	320	340	370	380	410	440	460	510	520	580
Size EWYD-BZSL	250	270	290	320	330	360	370	400	430	450	490	510	570

9 Options

9 - 2 Water pump kit

Water Pump Kit - Discharge Head

Single Pump (2 poles) - High Available external static pressure

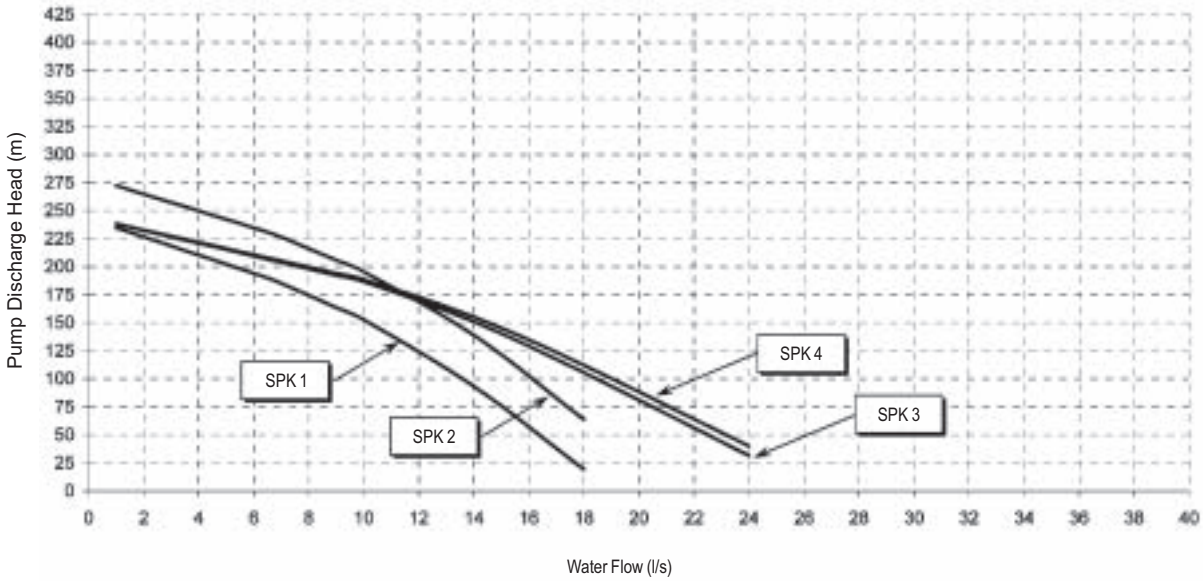

NOTES

- when using mixture of water and glycol please contact the factory as above specification can change

Single Pump (2 poles) - High Available external static pressure

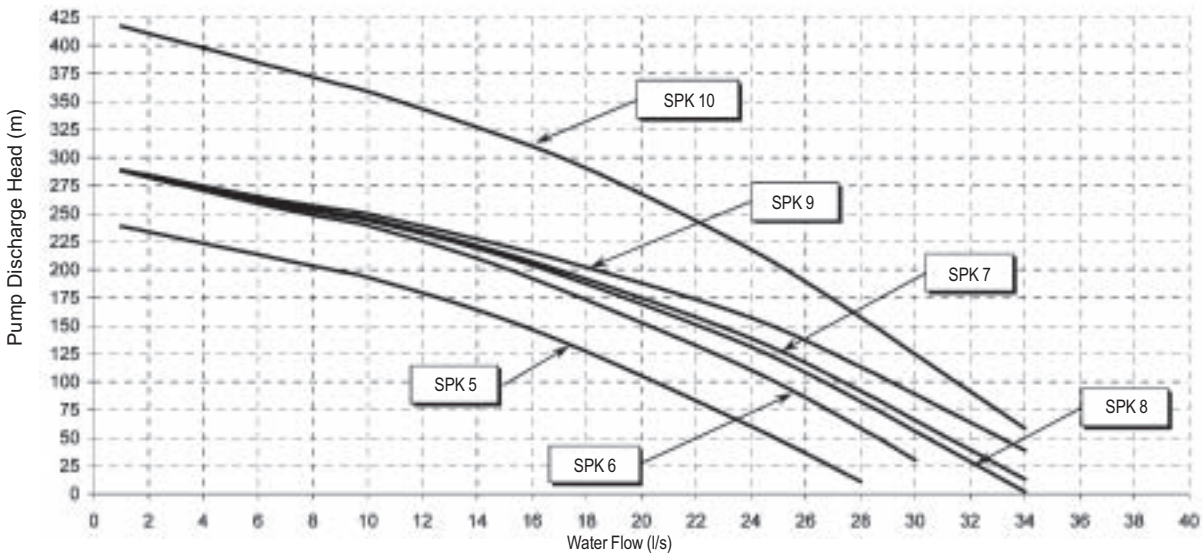

NOTES

- when using mixture of water and glycol please contact the factory as above specification can change

Pump Kit	SPK1	SPK2	SPK3	SPK4		SPK5	SPK6	SPK7		SPK8	SPK9	SPK10	
Size EWYD-BZSS	250	270	290	320	340	370	380	410	440	460	510	520	580
Size EWYD-BZSL	250	270	290	320	330	360	370	400	430	450	490	510	570

9 Options

9 - 2 Water pump kit

Water Pump Kit - Discharge Head

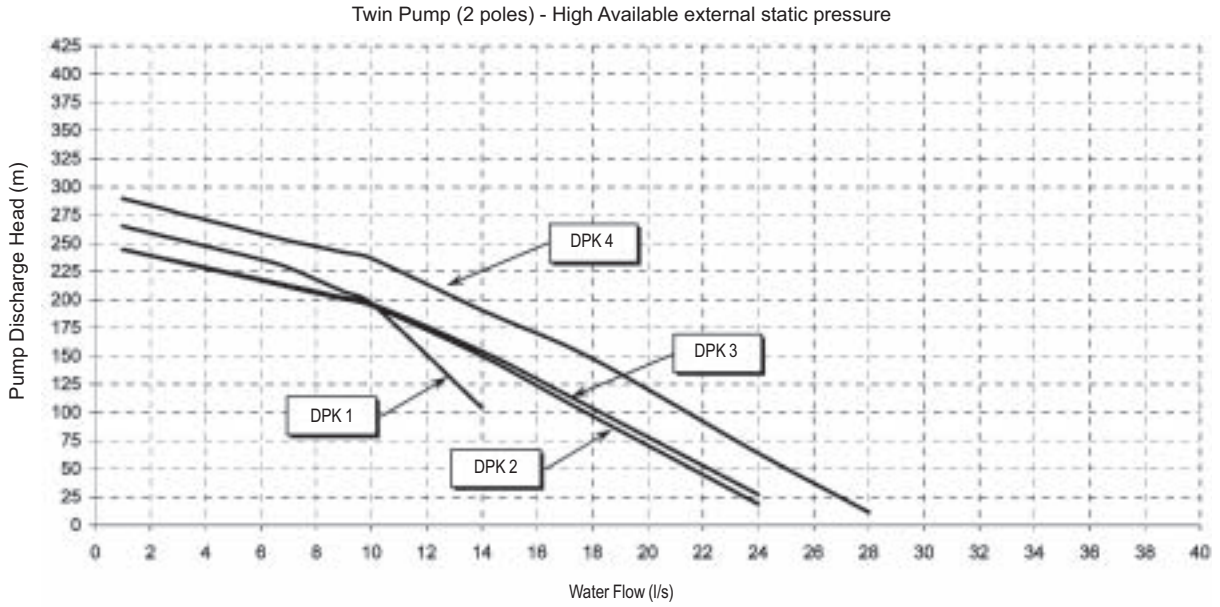

NOTES

- when using mixture of water and glycol please contact the factory as above specification can change

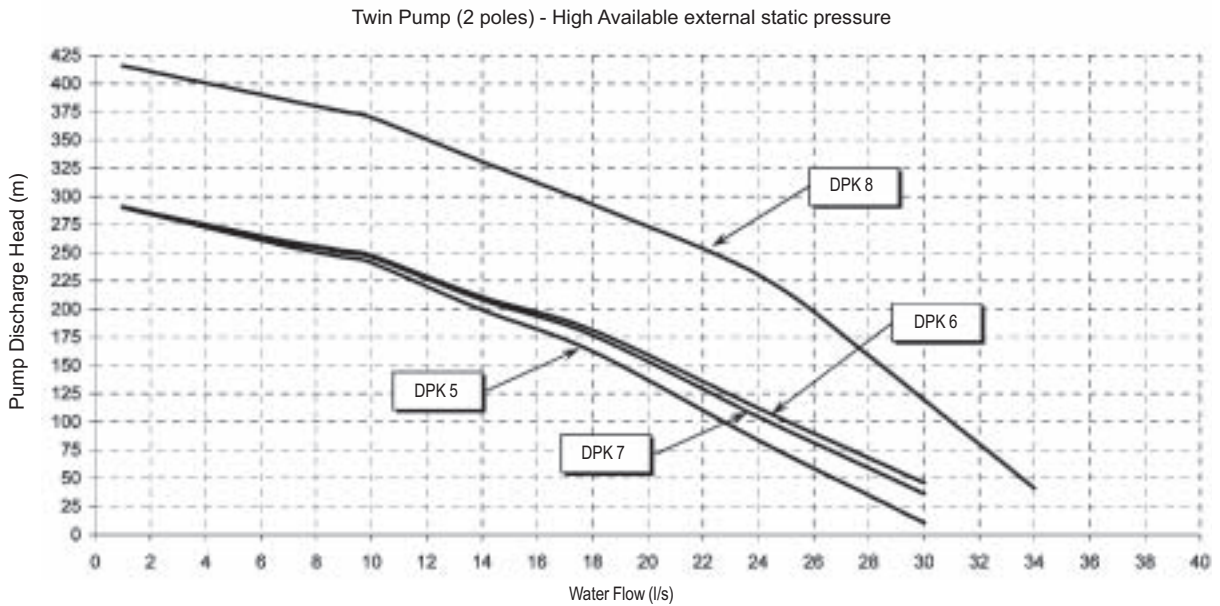

NOTES

- when using mixture of water and glycol please contact the factory as above specification can change

Pump Kit	DPK1	DPK2	DPK3	DPK4	DPK5	DPK6	DPK7	DPK8					
Size EWYD-BZSS	250	270	290	320	340	370	380	410	440	460	510	520	580
Size EWYD-BZSL	250	270	290	320	330	360	370	400	430	450	490	510	570

9 Options

9 - 2 Water pump kit

Water Pump Kit - Technical Information

		Pump Motor Power (kW)	Pump Motor Current (A)	Power supply (V-ph-Hz)	PN	Motor Protection	Insulation (Class)	Working Temp. (°C)
Single Pump Low Available Static Pressure	SPK 1	2,2	5,0	400V-3ph-50hz	10	IP55	Class F	-10 ÷ 130
	SPK 2	3,0	6,3	400V-3ph-50hz	10	IP55	Class F	-10 ÷ 130
	SPK 3	4,0	7,7	400V-3ph-50hz	10	IP55	Class F	-10 ÷ 130
	SPK 4	4,0	7,7	400V-3ph-50hz	10	IP55	Class F	-10 ÷ 130
	SPK 5	4,0	7,7	400V-3ph-50hz	10	IP55	Class F	-10 ÷ 130
	SPK 6	4,0	7,7	400V-3ph-50hz	10	IP55	Class F	-10 ÷ 130
	SPK 7	5,5	10,4	400V-3ph-50hz	10	IP55	Class F	-10 ÷ 130
	SPK 8	5,5	10,4	400V-3ph-50hz	10	IP55	Class F	-10 ÷ 130
	SPK 9	5,5	10,4	400V-3ph-50hz	10	IP55	Class F	-10 ÷ 130
	SPK 10	7,5	13,9	400V-3ph-50hz	10	IP55	Class F	-10 ÷ 130
Double Pump Low Available Static Pressure	DPK 1	3,0	6,3	400V-3ph-50hz	10	IP55	Class F	-10 ÷ 130
	DPK 2	4,0	7,7	400V-3ph-50hz	10	IP55	Class F	-10 ÷ 130
	DPK 3	4,0	7,7	400V-3ph-50hz	10	IP55	Class F	-10 ÷ 130
	DPK 4	4,0	7,7	400V-3ph-50hz	10	IP55	Class F	-10 ÷ 130
	DPK 5	5,5	10,4	400V-3ph-50hz	10	IP55	Class F	-10 ÷ 130
	DPK 6	5,5	10,4	400V-3ph-50hz	10	IP55	Class F	-10 ÷ 130
	DPK 7	5,5	10,4	400V-3ph-50hz	10	IP55	Class F	-10 ÷ 130
	DPK 8	5,5	10,4	400V-3ph-50hz	10	IP55	Class F	-10 ÷ 130
	DPK 9	7,5	13,9	400V-3ph-50hz	10	IP55	Class F	-10 ÷ 130

NOTES

- when using mixture of water and glycol please contact the factory as above specification can change

		Pump Motor Power (kW)	Pump Motor Current (A)	Power supply (V-ph-Hz)	PN	Motor Protection	Insulation (Class)	Working Temp. (°C)
Single Pump High Available Static Pressure	SPK 1	3,0	6,3	400V-3ph-50hz	10	IP55	Class F	-10 ÷ 130
	SPK 2	4,0	7,7	400V-3ph-50hz	10	IP55	Class F	-10 ÷ 130
	SPK 3	5,5	10,4	400V-3ph-50hz	10	IP55	Class F	-10 ÷ 130
	SPK 4	5,5	10,4	400V-3ph-50hz	10	IP55	Class F	-10 ÷ 130
	SPK 5	5,5	10,4	400V-3ph-50hz	10	IP55	Class F	-10 ÷ 130
	SPK 6	7,5	13,9	400V-3ph-50hz	10	IP55	Class F	-10 ÷ 130
	SPK 7	7,5	13,9	400V-3ph-50hz	10	IP55	Class F	-10 ÷ 130
	SPK 8	7,5	13,9	400V-3ph-50hz	10	IP55	Class F	-10 ÷ 130
	SPK 9	7,5	13,9	400V-3ph-50hz	10	IP55	Class F	-10 ÷ 130
	SPK 10	11,0	20,2	400V-3ph-50hz	10	IP55	Class F	-10 ÷ 130
Double Pump High Available Static Pressure	DPK 1	4,0	7,7	400V-3ph-50hz	10	IP55	Class F	-10 ÷ 130
	DPK 2	5,5	10,4	400V-3ph-50hz	10	IP55	Class F	-10 ÷ 130
	DPK 3	5,5	10,4	400V-3ph-50hz	10	IP55	Class F	-10 ÷ 130
	DPK 4	7,5	13,9	400V-3ph-50hz	10	IP55	Class F	-10 ÷ 130
	DPK 5	7,5	13,9	400V-3ph-50hz	10	IP55	Class F	-10 ÷ 130
	DPK 6	7,5	13,9	400V-3ph-50hz	10	IP55	Class F	-10 ÷ 130
	DPK 7	7,5	13,9	400V-3ph-50hz	10	IP55	Class F	-10 ÷ 130
	DPK 8	11,0	20,2	400V-3ph-50hz	10	IP55	Class F	-10 ÷ 130
	DPK 9	11,0	20,2	400V-3ph-50hz	10	IP55	Class F	-10 ÷ 130

NOTES

- when using mixture of water and glycol please contact the factory as above specification can change

10 Dimensional drawing & center of gravity

10 - 1 Dimensional drawing

EWYD-BZ

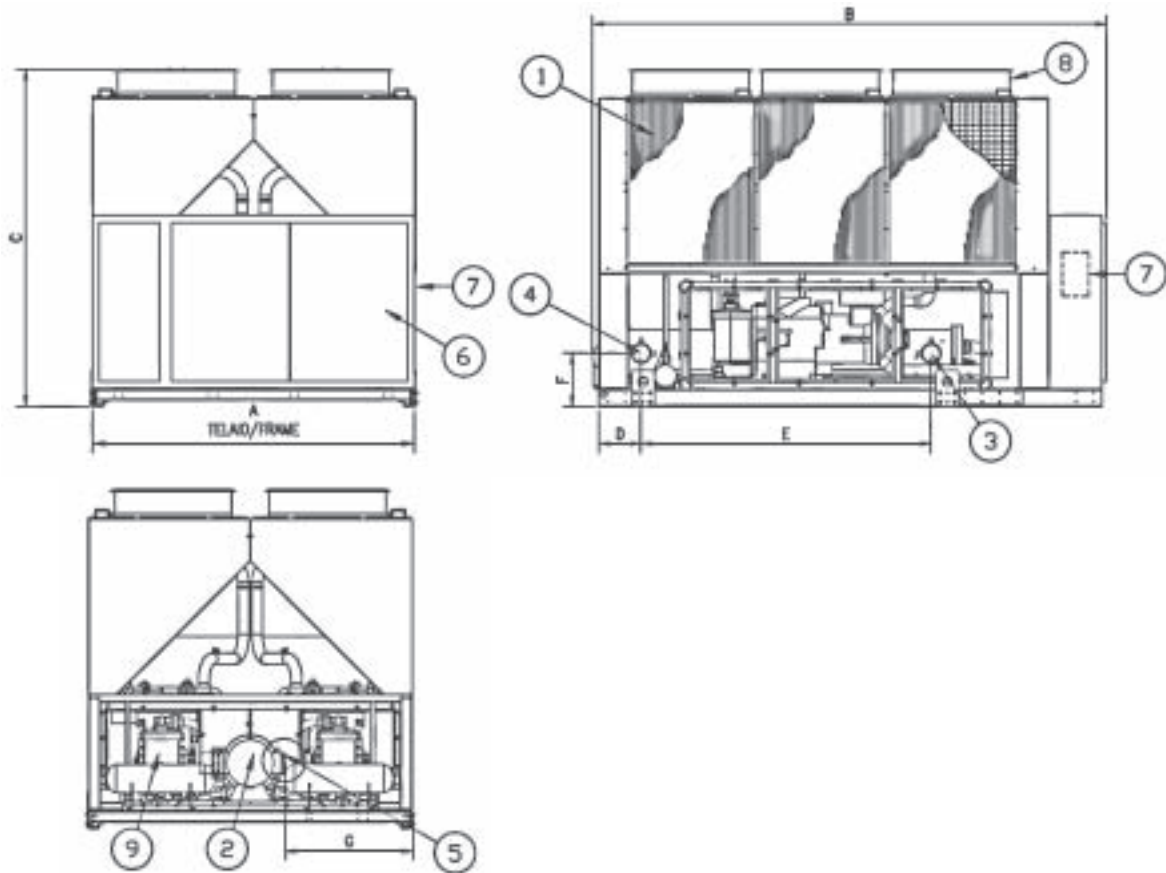

Size		Dimensions							
BZSS	BZSL	A	B	C	D	E	F	G	Fans
250	250	2254	3547	2335	288	2000	449	852	6
270	270	2254	3547	2335	288	2000	449	852	6
290	290	2254	3547	2335	288	2000	449	852	8
320	320	2254	4381	2335	290	2000	449	852	8
340	330	2254	4381	2335	290	2000	449	852	8
370	360	2254	4381	2335	290	2000	449	852	8
380	370	2254	4381	2335	290	2000	449	852	8
410	400	2254	5281	2335	290	2000	449	852	10
440	430	2254	5281	2335	290	2000	449	852	10
460	450	2254	6583	2335	290	2000	449	852	12
510	490	2254	6583	2335	451	1973	503	809	12
520	510	2254	6583	2335	451	1973	503	809	12
580	570	2254	6583	2335	451	1973	503	809	12

NOTES

- 1 Air heat exchanger (condenser – evaporator)
- 2 Water heat exchanger (evaporator – condenser)
- 3 Evaporator water inlet
- 4 Evaporator water outlet
- 5 Victaulic connection
- 6 Electrical control panel
- 7 Slot for power and control connection
- 8 Fan
- 9 Compressor

11 Installation

11 - 1 Installation method

Installation notes

Warning

Installation and maintenance of the unit must be performed only by qualified personnel who have knowledge with local codes and regulations, and experience with this type of equipment. Must be avoided the unit installation in places that could be considered dangerous for all the maintenance operations.

Handling

Care should be taken to avoid rough handling or shock due to dropping the unit. Do not push or pull the unit from anything other than the base frame. Never allow the unit to fall during unloading or moving as this may result in serious damage. To lift the unit, rings are provided in the base frame of the unit. Spreader bar and cables should be arranged to prevent damage to the condenser coil or unit cabinet.

Location

The units are produced for outside installation on roofs, floors or below ground level on condition that the area is free from obstacles for the passage of the condenser air. The unit should be positioned on solid foundations and perfectly level; in the case of installation on roofs or floors, it may be advisable to arrange the use of suitable weight distribution beams. When the units are installed on the ground, a concrete base at least 250 mm wider and longer than the unit's footprint should be laid. Furthermore, this base should withstand the unit weight mentioned in the technical data table.

Space requirements

The units are air-cooled, then it is important to respect the minimum distances which guarantee the best ventilation of the condenser coils. Limitations of space reducing the air flow could cause significant reductions in cooling capacity and an increase in electricity consumption.

To determinate unit placement, careful consideration must be given to assure a sufficient air flow across the condenser heat transfer surface. Two conditions must be avoided to achieve the best performance: warm air recirculation and coil starvation. Both these conditions cause an increase of condensing pressures that result in reductions in unit efficiency and capacity.

Moreover the unique microprocessor has the ability to calculate the operating environment of the air cooled chiller and the capacity to optimize its performance staying on-line during abnormal conditions.

Each side of the unit must be accessible after installation for periodic service. Fig.1 shows you minimum recommended clearance requirements.

Vertical condenser air discharge must be unobstructed because the unit would have its capacity and efficiency significantly reduced.

If the units are positioned in places surrounded by walls or obstacles of the same height as the units, the units should be at least 2500 mm from obstacles (fig.2). In the event the obstacles are higher than the units, the units should be at least 3000 mm from the obstacle (fig.4). Units installed closer than the minimum recommended distance to a wall or other vertical riser may experience a combination of coil starvation and warm air recirculation, thus causing reduction in unit capacity and efficiency reductions. The microprocessor control is proactive in response "of design condition". In the case of single or compounded influences restricting airflow to the unit, the microprocessor will act to keep the compressor(s) running (at reduced capacity) rather than allowing a shut-off on high discharge pressure.

When two or more units are positioned side by side it is recommended that the condenser coils are at least 3600 mm distance from one another (fig.3); strong wind could be the cause of air warm recirculation.

For other installation solutions, consult our technicians.

11 Installation

11 - 1 Installation method

Warning

The above recommended information are representative of general installation. A specific evaluation should be done by contractor depending on the case.

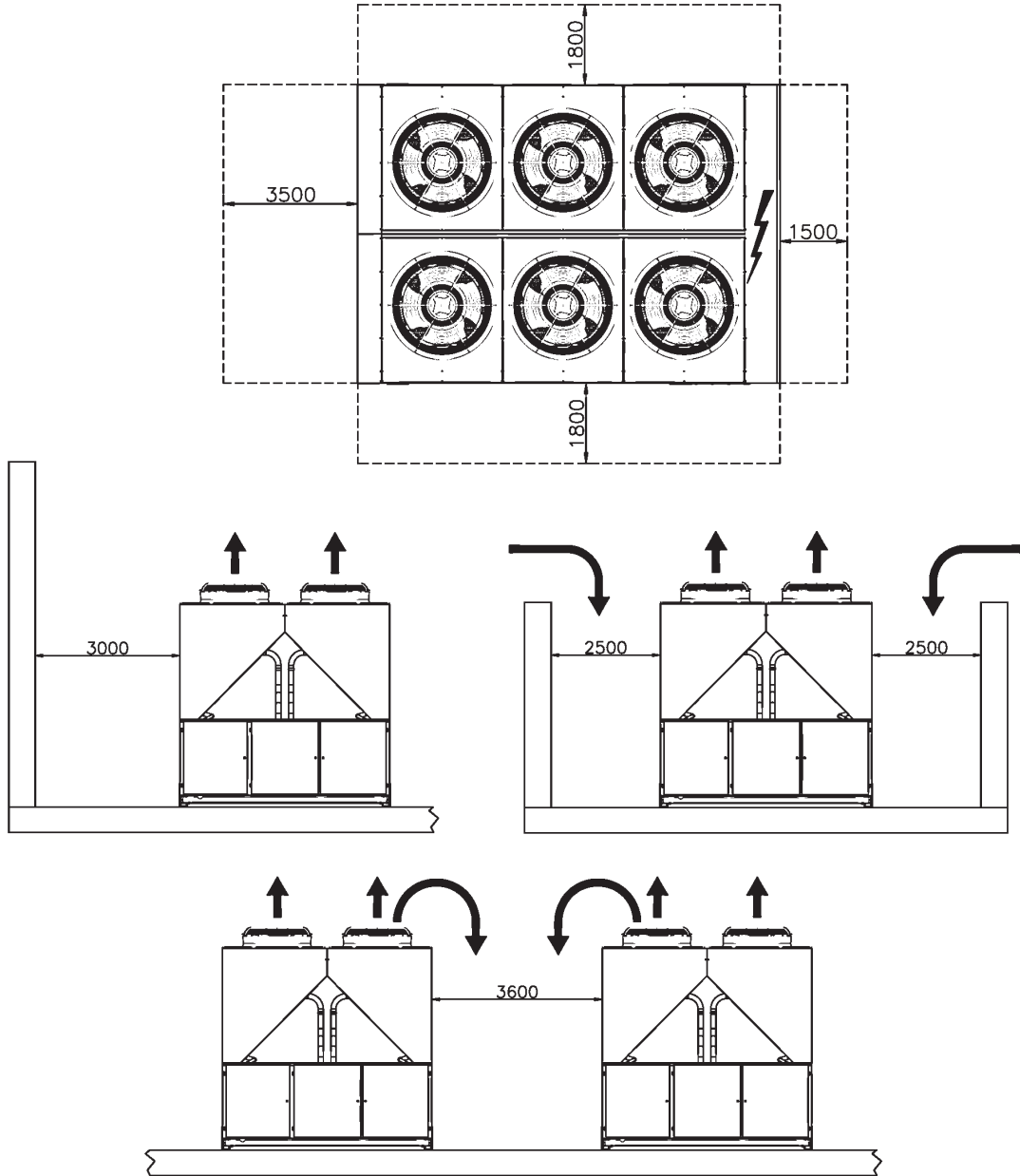

Acoustic protection

When noise level must meet special requirements, it is necessary to pay the maximum attention to ensure the perfect insulation of the unit from the support base by applying appropriate vibration-dampening devices on the unit, on the water pipes and on the electrical connections.

Storage

The environment conditions have to be in the following limits:

- Minimum ambient temperature: -20°C
- Maximum ambient temperature: +57°C
- Maximum R.H.: 95% not condensing

12 Specification

Technical Specification for Air Cooled Screw Chiller

GENERAL

The air to Water Heat Pump will be designed and manufactured in accordance with following European directives:

Rating of chillers	EN 12055
Construction of pressure vessel	97/23/EC (PED)
Machinery Directive	98/37/EC as modified
Low Voltage	2006/95/EC
Electromagnetic Compatibility	2004/108/EC
Electrical & Safety codes	EN 60204-1 / EN 60335-2-40
Manufacturing Quality Stds	UNI – EN ISO 9001:2000
Rating of chillers	EN 12055

The unit will be tested at full load in the factory at the nominal working conditions and water temperatures. Before shipment a full test will be held to avoid any losses.

Heat Pump will be delivered to the job site completely assembled and charged with right refrigerant and oil quantity. Comply with the manufacturer instructions for rigging and handling equipment.

The unit will be able to start up and operate as standard at full load and outside air temperature from °C to °C with an evaporator leaving fluid temperature between °C and 15 °C

All unit's published performances have to be certified by **Eurovent**.

REFRIGERANT

Only HFC 134a will be accepted.

PERFORMANCE

- ✓ Number of air to water heat pumps:
- ✓ Cooling capacity for single air to water heat pump: kW
- ✓ Power input for single air to water heat pump in cooling mode: kW
- ✓ Shell & tube heat exchanger entering water temperature in cooling mode: °C
- ✓ Shell & tube heat exchanger leaving water temperature in cooling mode: °C
- ✓ Shell & tube heat exchanger water flow: l/s
- ✓ Nominal outside working ambient temperature in cooling mode: °C

- ✓ Heating capacity for single air to water heat pump: kW
- ✓ Power input for single air to water heat pump in heating mode: kW
- ✓ Shell & tube heat exchanger entering water temperature in heating mode: °C
- ✓ Shell & tube heat exchanger leaving water temperature in heating mode: °C
- ✓ Shell & tube heat exchanger water flow: l/s
- ✓ Nominal outside working ambient temperature in heating mode: °C

- ✓ The unit should work with electricity in range 400 V ±10%, 3ph, 50Hz without neutral and shall only have one power connection point. The control circuit voltage shall be 24 V maximum, supplied by a factory-installed transformer.

UNIT DESCRIPTION

The unit shall include as standard not less than: two or three independent refrigerant circuits, semi-hermetic rotary single screw compressors, air-cooled variable electrical frequency driver for each compressor (VFD), electronic expansion device (EEXV), refrigerant direct expansion shell & tube heat exchanger, air-cooled condenser section, R134a refrigerant, lubrication system, motor starting components, suction line shut-off valve, discharge line shut-off valve, control system and all components necessary for safe and stable unit operation.

The unit will be factory assembled on a robust base-frame made of zinc coated steel, protected by an epoxy paint.

SPC_1a-2a-3a-4a-5a_Rev.00_1

12 Specification

NOISE LEVEL AND VIBRATIONS

Sound pressure level at 1 meter distance in free field, semispheric conditions, shall not exceeddB(A). The sound pressure levels must be rated in accordance to ISO 3744.

Other types of rating unacceptable. Vibration level should not exceed 2 mm/s.

DIMENSIONS

Unit dimensions shall not exceed following indications:

- ✓ unit length mm,
- ✓ unit width mm,
- ✓ unit height mm.

HEAT PUMP COMPONENTS

Compressors

- ✓ Semi-hermetic, single-screw type with one main helical rotor meshing with gaterotor. The gaterotor will be constructed of a carbon impregnated engineered composite material. The gaterotor supports will be constructed of cast iron.
- ✓ The oil injection shall be used in order to get high EER (Energy Efficiency Ratio) also at high condensing pressure and low sound pressure levels in each load condition.
- ✓ Refrigerant system differential pressure shall provide oil flow through service replaceable, 0.5 micron, full flow, cartridge type oil filter internal to compressor.
- ✓ Refrigerant system differential pressure shall provide oil injection on all moving compressor parts to correctly lubricate them. Electrical oil pump lubricating system is not acceptable.
- ✓ The compressor's oil cooling must be realized, when necessary, by refrigerant liquid injection. External dedicated heat exchanger and additional piping to carry the oil from the compressor to heat exchanger and viceversa will be not accepted.
- ✓ The compressor shall be provided with an integrated, high efficiency, cyclonic type oil separator and with built-in oil filter, cartridge type.
- ✓ The compressor shall be direct electrical driven, without gear transmission between the screw and the electrical motor.
- ✓ The compressor casing shall be provided with ports to realize economized refrigerant cycles.
- ✓ Shall be present two thermal protection realized by a thermistor for high temperature protection: one temperature sensor to protect electrical motor and another sensor to protect unit and lubricating oil from high discharge gas temperature.
- ✓ The compressor shall be equipped with an electric oil-crankcase heater.
- ✓ Compressor shall be fully field serviceable. Compressor that must be removed and returned to the factory for service shall be unacceptable.

Cooling capacity control system

- ✓ Each unit will have a microprocessor for the control of compressor inverter position and the instantaneous RPM value of the motor.
- ✓ The unit capacity control shall be infinitely modulating, both in cooling and in heating mode, from 100% down to 30% for each compressor (from 100% down to 13% of full load for units with 2 compressors and down to 9% of full load for units with 3 compressors).
- ✓ Step unloading unacceptable because of evaporator leaving water temperature fluctuation and low unit efficiency at partial load.
- ✓ The system shall stage the unit based on the leaving evaporator water temperature that shall be controlled by a PID (Proportional Integral Derivative) loop.
- ✓ Unit control logic shall to manage frequency level of the compressor electric motor to exactly match plant load request in order to keep constant the set point for delivered chilled or hot water temperature.
- ✓ In this operating condition unit control logic shall modulate electrical frequency level in a range lower and upper the nominal electrical network value fixed at 50 Hz.

12 Specification

- ✓ The microprocessor unit control shall detect conditions that approach protective limits and take self-corrective action prior to an alarm occurring. The system shall automatically reduce chiller capacity when any of the following parameters are outside their normal operating range:
 - High condenser pressure
 - Low evaporation refrigerant temperature
 - High compressor motor amps
- ✓ Air to water heat pump shall be able to deliver heating capacity (with -5°C outside ambient temperature) close to its nominal cooling capacity related at +35°C outside ambient temperature with +7°C for set-point of the leaving evaporator chilled water. In this condition unit shall be able to deliver 45°C hot water.

Unit-Mounted Variable Frequency Driver (VFD) and Electrical Requirement

- ✓ All interconnecting wiring between the VFD and the chiller shall be factory-installed. Customer electrical connection for compressor motor power shall be limited to main power leads to the single point power connection located into electrical panel.
- ✓ The VFD shall be air cooled type. Water cooled design or refrigerant cooled design are not acceptable.
- ✓ The VFD full load efficiency shall meet or exceed 97% at 100% VFD rated capacity.
- ✓ Base motor frequency shall permit motor to be utilized at nameplate voltage. Adjustable frequency range, monitored by unit's microprocessor control, shall permit a stable unit capacity control down to 13% (9% with 3 compressor unit) without hot-gas bypass.
- ✓ Starting current for the compressor shall not exceed nominal compressor load amps.
- ✓ Unit power factor shall be not less than 0.95 on entire unit capacity range, from 100% down to 13% (9% with 3 compressor unit).

Evaporator

- ✓ The units shall be supplied with shell and tubes counter-flow heat exchanger with single refrigerant pass. It will be refrigerant direct expansion type with refrigerant inside the tubes and water outside (shell side). It will include carbon steel tube sheets, with straight copper tubes internally wound for higher efficiencies, expanded on the tube plates.
- ✓ The external shell shall be linked with an electrical heater to prevent freezing down to -28°C ambient temperature, commanded by a thermostat and shall be insulated with flexible, closed cell polyurethane insulation material (10-mm thick).
- ✓ The evaporator will have 2 or 3 circuits, one for each compressor and shall be single refrigerant pass.
- ✓ The water connections shall be VICTAULIC type connections as standard to ensure quick mechanical disconnection between the unit and the hydronic network.
- ✓ Evaporator is manufactured in accordance to PED approval.

Condenser coil

- ✓ The condenser coils are constructed with internally finned seamless copper tubes having a "W" configuration and arranged in a staggered row pattern and mechanically expanded into lanced and rippled aluminium fins with full fin collars for higher efficiencies. The space between the fins are given by a collar that will increase the surface area in connection with the tubes, protecting them from ambient corrosion.
- ✓ The coils will have an integral subcooler circuit that provides sufficient subcooling to effectively eliminate the possibility of liquid flashing and increase the unit's efficiency of 5-7% without increasing in power absorption.
- ✓ The condenser coil shall be leak-tested and submitted to a pressure test with dry air.

Condenser fans

- ✓ The fans used in conjunction with the condenser coils, shall be propeller type with high efficiency design blades to maximize performances and lower noise. The material of the blades is glass reinforced resin and each fan is protected by a guard.
- ✓ The air discharge shall be vertical and each fan must be coupled to the electrical motor. Fan motor will be thermally protected (as standard) by internal thermal motor and protected by circuit breaker installed inside the electrical panel as a standard. The motor will be IP54.
- ✓ They shall have individual overload protection via a disconnect switch.

SPC_1a-2a-3a-4a-5a_Rev.00_3

12 Specification

Refrigerant circuit

- ✓ The unit must have refrigerant circuits completely independent of each other with one compressor and one variable electrical frequency driver per circuit (VFD).
- ✓ Each circuit shall include as standard: electronic expansion device piloted by unit's microprocessor control, compressor discharge shut-off valve, suction line shut-off valve, 4-way valve to reverse refrigerant cycle into the unit, liquid line shut-off valve with charging connection, replaceable core filter-drier, sight glass with moisture indicator and insulated suction line.

Condensation control

- ✓ The units will be provided with an automatic control for condensing pressure which ensures the working at low external temperatures down to +10 °C, thanks the ON/OFF of the condenser fans, to maintain condensing pressure. Fan speed control, to allow unit's operation with very low ambient temperature (-18°C), should be available as option.
- ✓ Automatic compressor unloading when abnormal high condensing pressure is detected to prevent the shutdown of the refrigerant circuit (shutdown of the unit) due to a high-pressure fault.

Low Noise unit options (on request)

- ✓ The unit compressors shall be connected with unit's metal baseframe by rubber antivibration supports to prevent the transmission of vibrations to all metal unit structure and so to control the unit noise.
- ✓ The discharge and suction lines shall be provided with mufflers to eliminate vibration and so to reduce the noise unit emission.
- ✓ The chiller shall be provided with an acoustically compressor enclosure. This enclosure shall be realized with a light, corrosion resisting aluminium structure and metal panels. The compressors sound-proof enclosure shall be internally fitted with flexible, multi layer, high density materials. The middle layer is 3 mm, very high density and high efficiency noise reduction material. The enclosure shall be carefully assembled to avoid decreasing of its noise reduction power.
- ✓ The chiller shall be provided with very low speed condenser fans and with an improved condenser section.

12 Specification

Control panel

- ✓ Field power connection, control interlock terminals, and unit control system should be centrally located in an electric panel (IP 54). Power and starting controls should be separate from safety and operating controls in different compartments of the same panel.
- ✓ Starting will be star/delta type.
- ✓ Power and starting controls should include fuses and contactors for each compressor winding and fan motors. Operating and safety controls should include energy saving control; emergency stop switch; overload protection for compressor motor; high and low pressure cut-out switch (for each refrigerant circuit); anti-freeze thermostat; cut-out switch for each compressor.
- ✓ All of the information regarding the unit will be reported on a display and with the internal built-in calendar and clock that will switch the unit ON/OFF during day time all year long.
- ✓ The following features and functions shall be included:
 - resetting chilled water temperature by controlling the return water temperature or by a remote 4-20 mA DC signal or by controlling the external ambient temperature;
 - soft load function to prevent the system from operating at full load during the chilled fluid pulldown period;
 - password protection of critical parameters of control;
 - start-to-start and stop-to-start timers to provide minimum compressor off-time with maximum motor protection;
 - communication capability with a PC or remote monitoring;
 - discharge pressure control through intelligent cycling of condenser fans;
 - lead-lag selection by manual or automatically by circuit run hours;
 - double set point for brine unit version;
 - scheduling via internal time clock to allow programming of a yearly start-stop schedule accommodating weekends and holidays.

Optional High Level Communications Interface

The controller as a minimum shall be capable of providing the data shown in the above list and document entitled McQuay-comms, using the following options:

- Option A RS485 Serial card
- Option B RS232 Serial card
- Option C LonWorks interface to FTT10A Transceiver
- Option D Bacnet Compatible



Daikin's unique position as a manufacturer of air conditioning equipment, compressors and refrigerants has led to its close involvement in environmental issues. For several years Daikin has had the intention to become a leader in the provision of products that have limited impact on the environment. This challenge demands the eco design and development of a wide range of products and an energy management system, resulting in energy conservation and a reduction of waste.



The present leaflet is drawn up by way of information only and does not constitute an offer binding upon Daikin Europe N.V.. Daikin Europe N.V. has compiled the content of this leaflet to the best of its knowledge. No express or implied warranty is given for the completeness, accuracy, reliability or fitness for particular purpose of its content and the products and services presented therein. Specifications are subject to change without prior notice. Daikin Europe N.V. explicitly rejects any liability for any direct or indirect damage, in the broadest sense, arising from or related to the use and/or interpretation of this leaflet. All content is copyrighted by Daikin Europe N.V.



Daikin Europe N.V. participates in the Eurovent Certification Programme for Air Conditioners (AC), Liquid Chilling Packages (LCP) and Fan Coil Units (FC); the certified data of certified models are listed in the Eurovent Directory. Multi units are Eurovent certified for combinations up to 2 indoor units.



EC DEN10-416

Daikin products are distributed by: