

1 Features and advantages

Features and advantages

Low operating cost

EWAD~E- is the result of careful design, aimed to optimizing the energy efficiency of the chillers, with the objective of bringing down operating costs and improving installation profitability, effectiveness and economical management.

The EWAD~E- chillers use the new very high efficiency single rotor screw compressor design, large condenser coil surface area for maximum heat transfer and low discharge pressure, advanced technology condenser fans, a plate to plate direct-expansion evaporator with low refrigerant pressure drops.

Low operating sound levels

Very low noise levels both at full load and part load conditions are achieved by the latest compressor design and by a unique new fan that moves large volume of air at exceptionally low sound levels and by the virtually vibration-free operation.

Excellent Serviceability

Field serviceability has not been sacrificed to meet design performance objectives. Compressor is equipped with combination discharge, liquid and suction shut off valves. Compressor and serviceable components such as filter-driers are located on the outside edges of the base allowing ready access. The shaped of the coil provides excellent room under the unit for inspection and service. The MicroTech III controller gives detailed information on the causes of an alarm or fault.

Proven Reliability

Full factory testing of every unit with water hook-up helps provide a trouble-free start-up. Extensive quality control checks during testing means that each equipment protection and operating control is properly adjusted and operates correctly before it leaves the factory.

Infinite capacity control

Cooling capacity control is infinitely variable by means of a single screw compressor controlled by microprocessor system. Each unit has infinitely variable capacity control from 100% down to 25%. This modulation allows the compressor capacity to exactly match the building cooling load without any leaving evaporator water temperature fluctuation. This chilled water temperature fluctuation is avoided only with a stepless control.

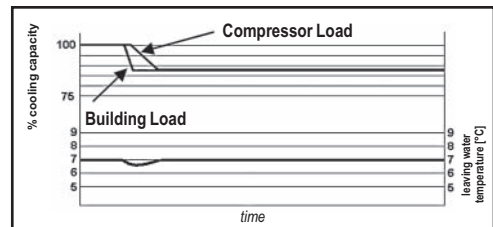

ELWT fluctuation with stepless capacity control

With a compressor load step control in fact, the compressor capacity, at partial loads, will be too high or too low compared to the building cooling load. The result is an increase in chiller energy costs, particularly at the part-load conditions at which the chiller operates most of the time.

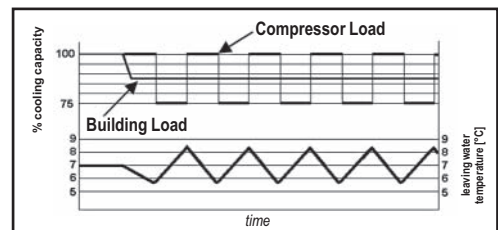

ELWT fluctuation with steps capacity control (4 steps)

Units with stepless regulation offer benefits that the units with step regulation are unable to match. The ability to follow the system energy demand at any time and the possibility to provide steady outlet water temperature without deviations from the set-point, are the two points that allow you to understand how the optimum operating conditions of a system can be met only through the use of a unit with step-less regulation.

1 Features and advantages

Superior control logic

The new MicroTech III controller provides an easy to use control environment. The control logic is designed to provide maximum efficiency, to continue operation in unusual operating conditions and to provide a history of unit operation. One of the greatest benefits is the easy interface with LonWorks, Bacnet, Ethernet TCP/IP or Modbus communications.

Code requirements – Safety and observant of laws/directives

All EWAD~E- units are designed and manufactured in accordance with applicable selections of the following:

Rating of chillers	EN 12055
Construction of pressure vessel	97/23/EC (PED)
Machinery Directive	98/37/EC as modified
Low Voltage	2006/95/EC
Electromagnetic Compatibility	2004/108/EC
Electrical & Safety codes	EN 60204-1 / EN 60335-2-40
Manufacturing Quality Stds	UNI – EN ISO 9001:2000

Certifications

All units manufactured by Daikin are CE marked, complying with European directives in force, concerning manufacturing and safety. On request units can be produced complying with laws in force in non European countries (ASME, GOST, etc.), and with other applications, such as naval (RINA, etc.).

Versions

EWAD~E- is available in one Efficiency Versions:

S: Standard Efficiency

10 sizes to cover a range from 98 up to 413 kW with an EER up to 2.98 and an ESEER up to 3.34 (data referred to Standard Noise)

The EER (Energy Efficiency Ratio) is the ratio of the Cooling Capacity to the Power Input of the unit. The Power Input includes: the power input for operation of the compressor, the power input of all control and safety devices, the power input for fans.

The ESEER (European Seasonal Energy Efficiency Ratio) is a weighed formula enabling to take into account the variation of EER with the load rate and the variation of air inlet condenser temperature.

$$ESEER = A \times EER_{100\%} + B \times EER_{75\%} + C \times EER_{50\%} + D \times EER_{25\%}$$

	A	B	C	D
Coefficient	0.03 (3%)	0.33 (33%)	0.41 (41%)	0.23 (23%)
Air inlet condenser temperature	35°C	30°C	25°C	20°C

Sound Configuration

EWAD~E- is available in two different Sound level configurations:

S: Standard Noise

Condenser fan rotating at 920 rpm, rubber antivibration on compressor

L: Low Noise

Condenser fan rotating at 715 rpm, rubber antivibration on compressor, compressor sound enclosure.

2 General characteristics

Cabinet and structure

The cabinet is made of galvanized steel sheet and painted to provide a high resistance to corrosion. Colour Ivory White (Munsell code 5Y7.5/1) (\pm RAL7044). The base frame has eye-hook for lifting the unit with ropes for an easy installation. The weight is uniformly distributed along the profiles of the base and this facilitates the arrangement of the unit.

Screw compressors with integrated oil separator

From size EWAD100E-SS to size EWAD 210E-SS and from size EWAD100E-SL to size EWAD210E-SL

The compressor is semi-hermetic, single-screw type with gate-rotors (made of carbon impregnated engineered composite material). The compressor has one slide managed by the unit microprocessor for infinitely modulating the capacity from 100% to 25%. An integrated high efficiency oil separator maximises the oil separation. Standard Start is Wye-delta (Y- Δ) type.

From size EWAD260E-SS to size EWAD 410E-SS and from size EWAD250E-SL to size EWAD400E-SL

The compressor is semi-hermetic, single-screw type with gate-rotor (with the latest high-strength fibre reinforced star material). The compressor has an asymmetric slide regulation managed by the unit controller for infinitely modulating capacity from 100% to 25%. An integrated high efficiency oil separator maximizes the oil separation. Standard Start is Wye-delta (Y- Δ) type.

Ecological HFC 134a refrigerant

The compressors have been designed to operate with R-134a, ecological refrigerant with zero ODP (Ozone Depletion Potential) and very low GWP (Global Warming Potential) that means low TEWI (Total Equivalent Warming Impact).

Evaporator

The units are equipped with a direct expansion plate to plate type heat exchanger evaporator. The heat exchanger is made of stainless steel brazed plates and is covered with a 10mm closed cell insulation material. The exchanger is equipped with an heater for protection against freezing down to -28°C .

Each evaporator has 1circuit (one compressor) and is manufactured in accordance to PED approval. The evaporator water outlet connections are 3".

Condenser coils

The condenser is manufactured with internally enhanced seamless copper tubes arranged in a staggered row pattern and mechanically expanded into lanced and rippled aluminium condenser fins with full fin collars. An integral sub-cooler circuit provides sub-cooling to effectively eliminate liquid flashing and increase in cooling capacity without increasing the power input.

Condenser coil fans

The condenser fans are propeller type with high efficiency design blades to maximize performances. The material of the blades is glass reinforced resin and each fan is protected by a guard. Fan motors are protected by circuit breakers installed inside the electrical panel as a standard. The motors are IP54.

Electronic expansion valve

The unit is equipped with the most advanced electronic expansion valves to achieve precise control of refrigerant mass flow. As today's system requires improved energy efficiency, tighter temperature control, wider range of operating conditions and incorporate features like remote monitoring and diagnostics, the application of electronic expansion valves becomes mandatory. Electronic expansion valve proposes features that make it unique: short opening and closing time, high resolution, positive shut-off function to eliminate use of additional solenoid valve, continuous modulation of mass flow without stress in the refrigerant circuit and corrosion resistance stainless steel body.

Electronic Expansion Valves are typically working with lower ΔP between high and low pressure side, than a thermostatic expansion valve. The electronic expansion valve allows the system to work with low condenser pressure (winter time) without any refrigerant flow problems and with a perfect chilled water leaving temperature control.

2 General characteristics

Refrigerant Circuit

Each unit has 1 refrigerant circuit and includes:

- Compressor with integrated oil separator
- Air Cooled Condenser
- Electronic expansion valve
- Evaporator
- Discharge line shut off valve
- Liquid line shut off valve
- Suction line shut off valve
- Sight glass with moisture indicator
- Filter drier
- Charging valves
- High pressure switch
- High and low pressure transducers

Electrical control panel

Power and control are located in the main panel that is manufactured to ensure protection against all weather conditions. The electrical panel is IP54 and (when opening the doors) internally protected with Plexiglas panel against possible accidental contact with electrical components (IP20). The main panel is fitted with a main switch interlocked door.

Power Section

The power section includes compressors fuses, fan circuit breaker, fan contactors and control circuit transformer.

MicroTech III controller

MicroTech III controller is installed as standard; it can be used to modify unit set-points and check control parameters. A built-in display shows chiller operating status plus temperatures and pressures of water, refrigerant and air, programmable values, set-points. A sophisticated software with predictive logic, selects the most energy efficient combination of compressors, EEXV and condenser fans to keep stable operating conditions to maximise chiller energy efficiency and reliability.

MicroTech III is able to protect critical components based on external signs from its system (such as motor temperatures, refrigerant gas and oil pressures, correct phase sequence, pressure switches and evaporator). The input coming from the high pressure switch cuts all digital output from the controller in less than 50ms, this is an additional security for the equipment.

Fast program cycle (200ms) for a precise monitoring of the system. Floating point calculations supported for increased accuracy in P/T conversions.

Control section - main features

- Management of the compressor stepless capacity and fans modulation.
- Chillers enabled to work in partial failure condition.
- Full routine operation at condition of:
 - high ambient temperature value
 - high thermal load
 - high evaporator entering water temperature (start-up)
- Display of evaporator entering/leaving water temperature.
- Display of Outdoor Ambient Temperature.
- Display of condensing-evaporating temperature and pressure, suction and discharge superheat for each circuit.
- Leaving water evaporator temperature regulation. Temperature tolerance = 0,1°C.
- Compressor and evaporator pumps hours counter.
- Display of Status Safety Devices.
- Number of starts and compressor working hours.

2 General characteristics

- Optimized management of compressor load.
- Fan management according to condensing pressure.
- Re-start in case of power failure (automatic / manual).
- Soft Load (optimized management of the compressors load during the start-up).
- Start at high evaporator water temperature.
- Return Reset (Set Point Reset based on return water temperature).
- OAT (Outside Ambient temperature) Reset.
- Set point Reset (optional).
- Application and system upgrade with commercial SD cards.
- Ethernet port for remote or local servicing using standard web browsers.
- Two different sets of default parameters could be stored for easy restore.

Safety device / logic for each refrigerant circuit

- High pressure (pressure switch).
- High pressure (transducer).
- Low pressure (transducer).
- Fans circuit breaker.
- High compressor discharge temperature.
- High motor winding temperature.
- Phase Monitor.
- Low pressure ratio.
- High oil pressure drop.
- Low oil pressure.
- No pressure change at start.

System security

- Phase monitor.
- Low Ambient temperature lock-out.
- Freeze protection.

Regulation type

Proportional + integral + derivative regulation on the leaving water evaporator output probe.

Condensing pressure

Condensing pressure can be controlled in according to the entering air temperature to the condenser coil. The fans can be managed either with steps, or with a 0/10 V modulating signal or with a mixed 0/10V + Steps strategy to cover all possible operational conditions.

MicroTech III

MicroTech III built-in terminal has the following features.

- 164x44 dots liquid crystal display with white back lighting. Supports Unicode fonts for multi-lingual.
- Key-pad consisting of 3 keys.
- Push'n'Roll control for an increased usability.
- Memory to protect the data.
- General faults alarm relays.
- Password access to modify the setting.

2 General characteristics

- Application security to prevent application tampering or hardware usability with third party applications.
- Service report displaying all running hours and general conditions.
- Alarm history memory to allow an easy fault analysis.

Supervising systems (on request)

MicroTech III remote control

MicroTech III is able to communicate to BMS (Building Management System) based on the most common protocols as:

- ModbusRTU
- LonWorks, now also based on the international 8040 Standard Chiller Profile and LonMark Technology
- BacNet BTP certified over IP and MS/TP (class 4) (Native)
- Ethernet TCP/IP.

Standard accessories (supplied on basic unit)

Wye-Delta Compressors starter (Y-D) – For low inrush current and reduced starting torque.

Double set-point – Dual leaving water temperature set-points.

Fans thermal overload relays – Safety devices against fan motor overloading in addition to the normal protection envisaged by the electrical windings.

Phase monitor – The phase monitor controls that phases sequence is correct and controls phase loss.

Evaporator Victaulic kit on water connection – Hydraulic joint with gasket for an easy and quick water connection.

10mm evaporator insulation

Evaporator electric heater – Electric heater controlled by a thermostat to protect the evaporator from freezing down to -28°C ambient temperature, providing the power supply is on.

Electronic expansion valve

Discharge line shut off valves – Installed on the discharge port of the compressor to facilitate maintenance operation.

Suction line shut off valve – Installed on the suction port of the compressor to facilitate maintenance operation.

Outside ambient temperature sensor and reset of leaving water temperature set-point.

Compressor hour run meter.

General fault – Alarm relay.

Set-point reset – The leaving water temperature set-point can be overwritten with the following options: 4-20mA from external source (by user); outside ambient temperature; evaporator water temperature Δt .

Demand limit – User can limit the load of the unit by 4-20mA signal or by network system

Alarm from external device – Microprocessor is able to receive an alarm signal from an external device (pump etc...). User can decide if this alarm signal will stop or not the unit.

Main switch interlock door

Emergency stop

Fans circuit breakers – Safety device against motor overloading and short circuit

Low pressure side manometers

2 General characteristics

Options (on request)

Total heat recovery – Produced with plate to plate heat exchangers to produce hot water.

Partial heat recovery – Produced with plate to plate heat exchangers installed between the compressor discharge and the condenser coil, allowing to produce hot water.

Soft starter – Electronic starting device to reduce the mechanical stress during compressor start-up.

Brine version – Allows the unit to operate down to -8°C leaving liquid temperature (antifreeze required).

Compressor thermal overload relays – Safety devices against compressor motor overloading. This device together with internal motor protection (standard) guarantee the best safety system for compressor motor.

Under/Over Voltage – This device control the voltage value of power supply and stop the chiller if the value exceeds the allowed operating limits.

Energy Meter – This device allows to measure the energy absorbed by the chiller during its life. It is installed inside the control box mounted on a DIN rail and show on a digital display: Line-to-Line Voltage, Phase and Average Current, Active and Reactive Power, Active Energy, Frequency.

Capacitors for power factor correction – To increase the operating power factor of the unit at nominal operating conditions. The capacitors are “dry” self-regenerating type with over pressure disconnection safety device insulated with a no toxic dielectric mix with no PCB or PCT.

Current limit – To limit maximum absorbed current of the unit whenever is required
20mm evaporator insulation

Fan speed regulation – To control the fan speed revolution for smooth operating control of the unit. This option improves the sound level of the unit during low ambient temperature operation.

With “Fan speed regulation” option, by different microprocessor setting, it is also possible to set the “Fan Silent Mode” configuration. It means that the microprocessor clock switches the fan at low speed according to the client setting (i.e. Night & Day), providing that the ambient temperature/condensing pressure is allowing the speed change.

It allows a perfect condensing control down to -10°C.

Speedtrol – Continuous fan speed modulation on the first fan of each circuit. It allows the unit working with air temperature down to -18°C.

Condenser coil guards

Cu-Cu condensing coils – To give better protection against corrosion by aggressive environments.

Cu-Cu-Sn condensing coils – To give better protection against corrosion in aggressive environments and by salty air.

Alucoat condensing coils – Fins are protected by a special acrylic paint with a high resistance to corrosion.

Evaporator Flow switch – Supplied separately to be wired and installed on the evaporator water piping (by the customer).

High pressure gauges.

Kit container

Rubber type anti vibration mounts – Supplied separately, these are positioned under the base of the unit during installation. Ideal to reduce the vibrations when the unit is floor mounted.

Spring type anti vibration mounts – Supplied separately, these are positioned under the base of the unit during installation. Ideal for dampening vibrations for installation on roofs and metallic structures.

Hydronic Kit (single water pump - low or high lifting) – Hydronic kit consists of: single direct driven centrifugal pump, water filling system with pressure gauge, safety valve, drain valve. The motor pump is protected by a circuit breaker installed in control panel. The kit is assembled and wired to the control panel. The pipe and pump are protected from freezing with an additional electrical heater.

Hydronic Kit (twin water pumps - low or high lifting) – (Not available on sizes EWAD100E-SS / SL and EWAD120E-SS / SL) Hydronic kit consists of: twin direct driven centrifugal pumps, water filling system with pressure gauge, safety valve, drain valve. The motor pump is protected by a circuit breaker installed in control panel. The kit is assembled and wired to the control panel. The pipe and pumps are protected from freezing with an additional electrical heater.

Witness test – Every unit is always tested at the test bench prior to the shipment. On request, a second test can be carried out, at customer’s presence, in accordance with the procedures indicated on the test form. (Not available for units with glycol mixtures).

Acoustic test – On request, a test can be carried out, at customer’s presence (Not available for units with glycol mixtures).

Compressors circuit breakers.

Double pressure relief valve with diverter

3 Nomenclature

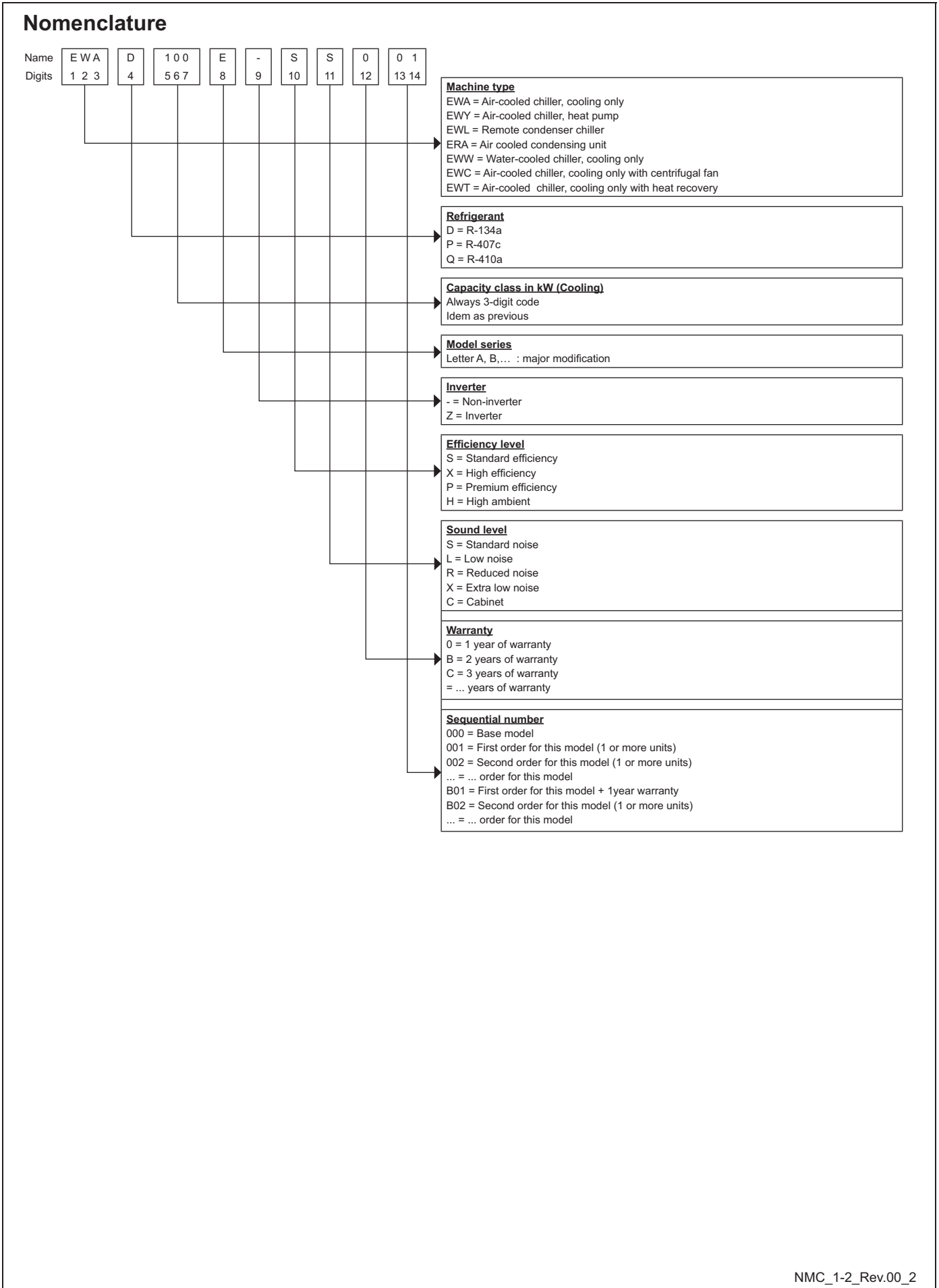

4 Technical specifications

4-1 Technical Specifications			EWAD~E-SS		100	120	140	160	180	210	260	310	360	410	
Capacity (1)	Cooling	kW	101	121	138	163	183	214	256	307	360	413			
Capacity control	Type	---	Stepless												
	Minimum capacity	%	25												
Unit power input (1)	Cooling	kW	38.7	46.9	53.4	60.3	68.5	71.7	86.7	111	133	146			
EER (1)		---	2.61	2.57	2.58	2.70	2.67	2.98	2.95	2.77	2.71	2.84			
ESEER		---	2.93	2.93	2.75	2.93	2.81	3.02	3.18	3.05	3.23	3.34			
IPLV		---	3.36	3.25	2.98	3.13	3.25	3.48	3.68	3.57	3.61	3.65			
Casing	Colour	---	Ivory White												
	Material	---	Galvanized and painted steel sheet												
Dimensions	Unit	Height	mm	2273	2273	2273	2273	2273	2273	2223	2223	2223	2223		
		Width	mm	1292	1292	1292	1292	1292	1292	1292	2236	2236	2236	2236	
		Length	mm	2165	21965	3065	3065	3965	3965	3070	3070	3070	3070	3070	
Weight	Unit	kg	1651	1684	1806	1861	2023	2086	2522	2745	2855	2919			
	Operating Weight	kg	1663	1699	1823	1881	2047	2116	2547	2775	2891	2963			
Water heat exchanger	Type	---	Plate to plate												
	Water volume	l	12	15	17	20	24	30	25	30	36	44			
	Nominal water flow rate	Cooling	l/s	4.83	5.76	6.58	7.77	8.74	10.22	12.22	14.65	17.21	19.74		
	Nominal water pressure drop	Cooling	kPa	24	25	24	24	22	21	48	48	48	45		
	Insulation material			Closed cell											
Air heat exchanger	Type	---	High efficiency fin and tube type with integral subcooler												
Fan	Type	---	Direct propeller type												
	Drive	---	DOL												
	Diameter	mm	800												
	Nominal air flow	l/s	10922	10575	16383	15863	21844	21150	32767	32767	31725	31725			
	Model	Quantity	No.	2	2	3	3	4	4	6	6	6	6		
		Speed	rpm	920											
Motor input		W	1.75												
Compressor	Type	---	Semi-hermetic single screw compressor Inverter driven												
	Oil charge	l	13	13	13	13	13	13	16	19	19	19			
	Quantity	No.	1												
Sound level	Sound Power	Cooling	dB(A)	91.5	91.5	92.3	92.3	93.0	94.2	94.2	94.5	94.5	95.2		
	Sound Pressure (2)	Cooling	dB(A)	73.5	73.5	73.7	73.7	73.9	75.1	75.0	75.3	75.3	76		
Refrigerant circuit	Refrigerant type	---	R-134a												
	Refrigerant charge	kg.	18	21	23	28	30	33	46	46	56	60			
	N. of circuits	No.	1												
Piping connections	Evaporator water inlet/outlet	mm	3												
Safety devices	High discharge pressure (pressure switch)														
	High discharge pressure (pressure transducer)														
	Low suction pressure (pressure transducer)														
	Compressor overload (Kriwan)														
	High discharge temperature														
	Low oil pressure														
	Low pressure ratio														
	High oil filter pressure drop														
	Phase monitor														
	Water freeze protection controller														
	Notes (1)	Cooling capacity, unit power input in cooling and EER are based on the following conditions: evaporator 12/7°C; ambient 35°C, unit at full load operation.													
Notes (2)	The values are according to ISO 3744 and are referred to: evaporator 12/7°C, ambient 35°C, full load operation.														

4 Technical specifications

4-2 Electrical Specifications		EWAD~E-SS	100	120	140	160	180	210	260	310	360	410	
Power Supply	Phase	---	3										
	Frequency	Hz	50										
	Voltage	V	400										
	Voltage Tolerance	Minimum	%	-10%									
		Maximum	%	+10%									
Unit	Maximum starting current	A	156		203	213	298		395	425			
	Nominal running current cooling	A	67	82	91	113	118	124	144	184	223	248	
	Maximum running current	A	81	97	112	132	149	155	185	224	270	281	
	Maximum current for wires sizing	A	89	107	123	146	164	170	204	246	297	309	
Fans	Nominal running current in cooling	A	2,5										
Compressor	Phase	No.	3										
	Voltage	V	400										
	Voltage Tolerance	Minimum	%	-10%									
		Maximum	%	+10%									
	Maximum running current	A	80	96	107	121	145		171	224	264		
	264	---	Wye – Delta type (Y – Δ)										
Notes	Allowed voltage tolerance $\pm 10\%$. Voltage unbalance between phases must be within $\pm 3\%$.												
	Maximum starting current: starting current of biggest compressor + current of the compressor at 75% maximum load + fans current for the circuit at 75%.												
	Nominal current in cooling mode is referred to installation with 25kA short circuit current and is based on the following conditions: evaporator 12°C/7°C; ambient 35°C.compressor + fans current.												
	Maximum running current is based on max compressor absorbed current in its envelope and max fans absorbed current												
	Maximum current for wires sizing: (compressors full load ampere + fans current) x 1,1.												

4 Technical specifications

4-3 Technical Specifications			EWAD-E-SL	100	120	140	160	180	210	260	310	360	410
Capacity (1)	Cooling		kW	97,9	116	134	157	177	209	249	296	345	398
Capacity control	Type		---	Stepless									
	Minimum capacity		%	25									
Unit power input (1)	Cooling		kW	38,8	47,9	53,0	60,6	67,8	72,1	84,5	110	134	150
EER (1)			---	2,52	2,42	2,53	2,60	2,61	2,89	2,95	2,69	2,58	2,65
ESEER			---	3,01	2,97	2,85	3,00	3,07	3,32	3,55	3,41	3,34	3,45
IPLV			---	3,32	3,21	3,30	3,46	3,28	3,48	3,86	3,75	3,63	3,76
Casing	Colour		---	Ivory White									
	Material		---	Galvanized and painted steel sheet									
Dimensions	Unit	Height	mm	2273	2273	2273	2273	2273	2273	2223	2223	2223	2223
		Width	mm	1292	1292	1292	1292	1292	1292	1292	2236	2236	2236
		Length	mm	2165	2165	3065	3065	3965	3965	3070	3070	3070	3070
Weight	Unit		kg	1768	1801	1923	1978	2140	2203	2639	2862	2972	3036
	Operating Weight		kg	1780	1815	1940	1998	2164	2232	2664	2892	3008	3079
Water heat exchanger	Type		---	Plate to plate									
	Water volume		l	12	15	17	20	24	30	25	30	36	44
	Nominal water flow rate	Cooling	l/s	4,68	5,54	6,40	7,51	8,47	9,97	11,90	14,15	16,50	19,01
	Nominal water pressure drop	Cooling	kPa	23	23	23	23	21	20	46	45	44	42
	Insulation material			Closed cell									
Air heat exchanger	Type		---	High efficiency fin and tube type with integral subcooler									
Fan	Type		---	Direct propeller type									
	Drive		---	DOL									
	Diameter		mm	800									
	Nominal air flow		l/s	8372	8144	12558	12217	16744	16289	25117	25117	24433	24433
	Model	Quantity	No.	2	2	3	3	4	4	6	6	6	6
		Speed	rpm	715									
Motor input		W	0,78										
Compressor	Type		---	Semi-hermetic single screw compressor Inverter driven									
	Oil charge		l	13	13	13	13	13	13	16	19	19	19
	Quantity		No.	1									
Sound level	Sound Power	Cooling	dB(A)	89,0	89,0	89,8	89,8	90,5	91,7	91,7	92,0	92,0	92,7
	Sound Pressure (2)	Cooling	dB(A)	71,0	71,0	71,2	71,2	71,4	72,6	72,5	72,8	72,8	73,5
Refrigerant circuit	Refrigerant type		---	R-134a									
	Refrigerant charge		kg.	18	21	23	28	30	33	46	46	56	60
	N. of circuits		No.	1									
Piping connections	Evaporator water inlet/outlet		mm	3									
Safety devices	High discharge pressure (pressure switch)												
	High discharge pressure (pressure transducer)												
	Low suction pressure (pressure transducer)												
	Compressor overload (Kriwan)												
	High discharge temperature												
	Low oil pressure												
	Low pressure ratio												
	High oil filter pressure drop												
	Phase monitor												
	Water freeze protection controller												
Notes (1)	Cooling capacity, unit power input in cooling and EER are based on the following conditions: evaporator 12/7°C; ambient 35°C, unit at full load operation.												
Notes (2)	The values are according to ISO 3744 and are referred to: evaporator 12/7°C, ambient 35°C, full load operation.												

4 Technical specifications

4-4 Electrical Specifications		EWAD~E-SL	100	120	140	160	180	210	260	310	360	410	
Power Supply	Phase	---	3										
	Frequency	Hz	50										
	Voltage	V	400										
	Voltage Tolerance	Minimum	%	-10%									
		Maximum	%	+10%									
Unit	Maximum starting current	A	159		207		304		404	434			
	Nominal running current cooling	A	67	81	92	102	119	124	148	185	220	241	
	Maximum running current	A	85	100	116	129	155	161	195	238	276	291	
	Maximum current for wires sizing	A	93	109	128	142	171	177	214	262	303	320	
Fans	Nominal running current in cooling	A	4										
Compressor	Phase	No.	3										
	Voltage	V	400										
	Voltage Tolerance	Minimum	%	-10%									
		Maximum	%	+10%									
	Maximum running current	A	80	96	107	121	145	171	224	264			
Starting method	---	Wye – Delta type (Y – Δ)											
Notes	Allowed voltage tolerance $\pm 10\%$. Voltage unbalance between phases must be within $\pm 3\%$.												
	Maximum starting current: starting current of biggest compressor + current of the compressor at 75% maximum load + fans current for the circuit at 75%.												
	Nominal current in cooling mode is referred to installation with 25kA short circuit current and is based on the following conditions: evaporator 12°C/7°C; ambient 35°C.compressor + fans current.												
	Maximum running current is based on max compressor absorbed current in its envelope and max fans absorbed current												
	Maximum current for wires sizing: (compressors full load ampere + fans current) x 1,1.												

5 Sound Levels

Noise Level

EWAD-E-SS

Unit size	Sound pressure level at 1 m from the unit in semispheric free field (rif. 2 x 10 ⁻⁵ Pa)									Power
	63 Hz	125 Hz	250 Hz	500 Hz	1000 Hz	2000 Hz	4000 Hz	8000 Hz	dB(A)	dB(A)
100	75,5	70,8	68,9	75,3	64,3	61,7	53,0	47,3	73,5	91,5
120	75,5	70,8	68,9	75,3	64,3	61,7	53,0	47,3	73,5	91,5
140	75,7	71,0	69,1	75,5	64,5	61,9	53,2	47,5	73,7	92,3
160	75,7	71,0	69,1	75,5	64,5	61,9	53,2	47,5	73,7	92,3
180	75,9	71,2	69,3	75,7	64,7	62,1	53,4	47,7	73,9	93,0
210	77,1	72,4	70,5	76,9	65,9	63,3	54,6	48,9	75,1	94,2
260	77,0	72,3	70,4	76,8	65,8	63,2	54,5	48,8	75,0	94,2
310	77,3	72,6	70,7	77,1	66,1	63,5	54,8	49,1	75,3	94,5
360	77,3	72,6	70,7	77,1	66,1	63,5	54,8	49,1	75,3	94,5
410	78,0	73,3	71,4	77,8	66,8	64,2	55,5	49,8	76,0	95,2

EWAD-E-SL

Unit size	Sound pressure level at 1 m from the unit in semispheric free field (rif. 2 x 10 ⁻⁵ Pa)									Power
	63 Hz	125 Hz	250 Hz	500 Hz	1000 Hz	2000 Hz	4000 Hz	8000 Hz	dB(A)	dB(A)
100	73,0	68,3	66,4	72,8	61,8	59,2	50,5	44,8	71,0	89,0
120	73,0	68,3	66,4	72,8	61,8	59,2	50,5	44,8	71,0	89,0
130	73,2	68,5	66,6	73,0	62,0	59,4	50,7	45,0	71,2	89,8
160	73,2	68,5	66,6	73,0	62,0	59,4	50,7	45,0	71,2	89,8
180	73,4	68,7	66,8	73,2	62,2	59,6	50,9	45,2	71,4	90,5
210	74,6	69,9	68,0	74,4	63,4	60,8	52,1	46,4	72,6	91,7
250	74,5	69,8	67,9	74,3	63,3	60,7	52,0	46,3	72,5	91,7
300	74,8	70,1	68,2	74,6	63,6	61,0	52,3	46,6	72,8	92,0
350	74,8	70,1	68,2	74,6	63,6	61,0	52,3	46,6	72,8	92,0
400	75,5	70,8	68,9	75,3	64,3	61,7	53,0	47,3	73,5	92,7

NOTES

The values are according to ISO 3744 and are referred to: evaporator 12/7° C, air ambient 35° C, full load operation

5 Sound Levels

Sound pressure level correction factors for different distances

EWAD-E-SS and EWAD-E-SL

Unit size		Distance						
EWAD-E-SS	EWAD-E-SL	1m	5m	10m	15m	20m	25m	50m
100	100	0,0	8,8	13,9	17,1	19,4	21,2	27,0
120	120	0,0	8,8	13,9	17,1	19,4	21,2	27,0
140	130	0,0	8,5	13,5	16,6	18,9	20,7	26,5
160	160	0,0	8,5	13,5	16,6	18,9	20,7	26,5
180	180	0,0	8,2	13,1	16,2	18,4	20,3	26,0
210	210	0,0	8,2	13,1	16,2	18,4	20,3	26,0
260	250	0,0	8,1	13,0	16,1	18,4	20,2	25,9
310	300	0,0	8,1	13,0	16,1	18,4	20,2	25,9
360	350	0,0	8,1	13,0	16,1	18,4	20,2	25,9
410	400	0,0	8,1	13,0	16,1	18,4	20,2	25,9

6 Operating limits

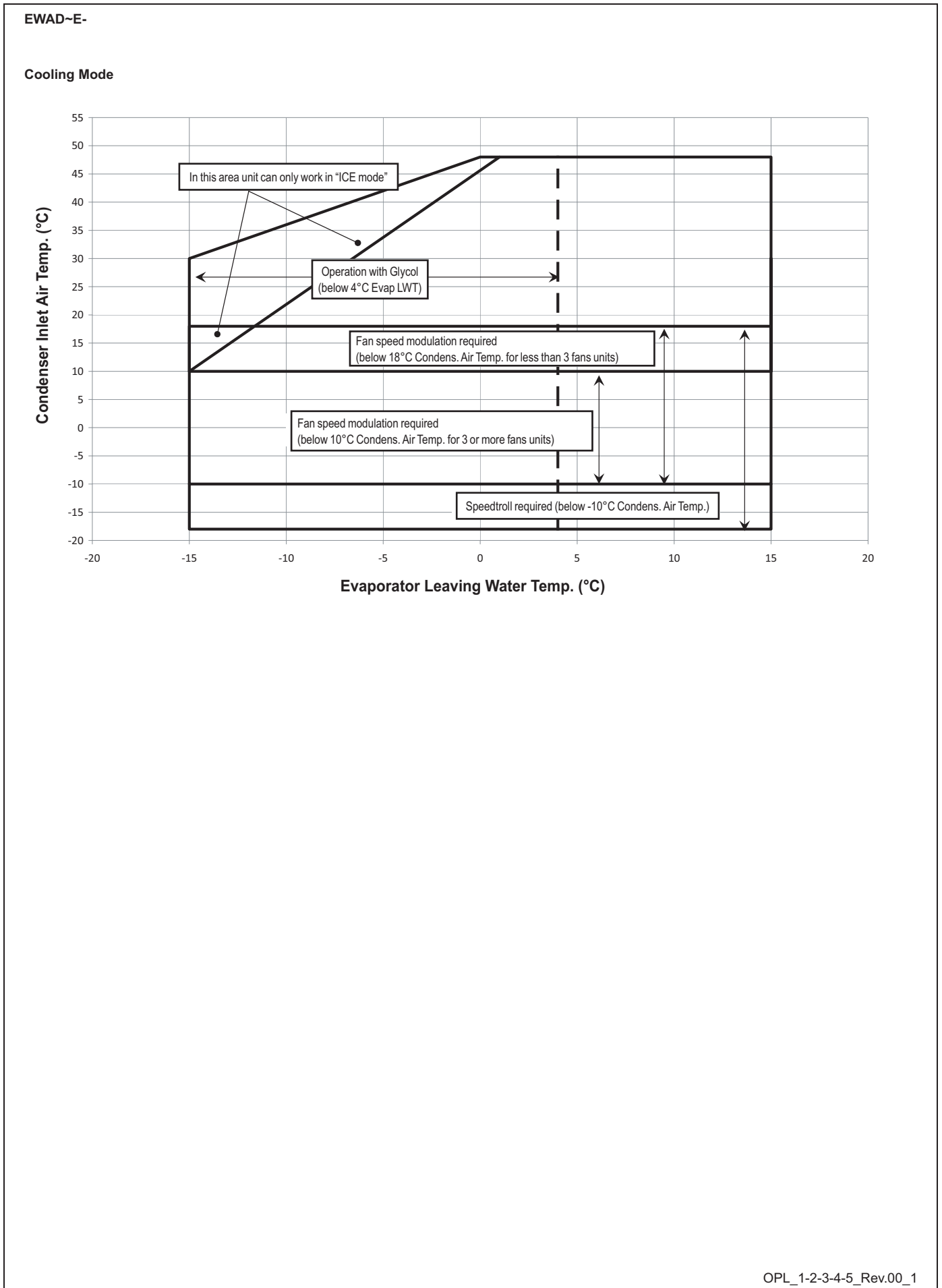

6 Operating limits

EWAD~E-

Water heat exchanger - Minimum and maximum water Δt

Max evaporator water Δt	°C	8
Min evaporator water Δt	°C	4

Water heat exchanger - Fouling factors

Fouling factors m ² °C / kW	Cooling capacity correction factor	Power input correction factor	EER correction factor
0,0176	1,000	1,000	1,000
0,0440	0,978	0,986	0,992
0,0880	0,957	0,974	0,983
0,1320	0,938	0,962	0,975

Air heat exchanger - Altitude correction factors

Elevation above sea level (m)	0	300	600	900	1200	1500	1800
Barometric pressure (mbar)	1013	977	942	908	875	843	812
Cooling capacity correction factor	1,000	0,993	0,986	0,979	0,973	0,967	0,960
Power input correction factor	1,000	1,005	1,009	1,015	1,021	1,026	1,031

- Maximum operating altitude is 2000 m above sea level
- Contact factory in case the unit has to be installed at altitudes between 1000 and 2000 m above sea level

Minimum glycol percentage for low water temperature

EWLT (°C)	2	0	-2	-4	-6	-8	-10	-12	-15
Ethylene glycol (%)	10	20	20	20	30	30	30	40	40
Propylene glycol (%)	10	20	20	30	30	30	40	40	40

- ELWT (Evaporator Leaving Water Temperature (°C))
- Minimum glycol percentage to be used with evaporator leaving water temperature below 4°C to prevent freezing of water circuit.

Minimum glycol percentage for low air ambient temperature

Air Ambient Temperature (°C) (2)	-3	-8	-15	-20
Ethylene glycol (%) (1)	10%	20%	30%	40%
Air Ambient Temperature (°C) (2)	-3	-7	-12	-20
Propylene glycol (%) (1)	10%	20%	30%	40%

- Minimum glycol percentage to prevent freezing of water circuit at indicated air ambient temperature
- Air ambient temperature do exceed the operating limits of the unit, as protection of water circuit may be needed in winter season at non-working conditions.

Correction factors for low evaporator leaving water temperature (EWLT < 4°C)

Evaporator Leaving Water Temperature (°C)	2	0	-2	-4	-6	-8	-10	-12	-15
Cooling Capacity	0,842	0,785	0,725	0,670	0,613	0,562	0,510	0,455	0,375
Compressor Power Input	0,950	0,940	0,920	0,890	0,870	0,840	0,798	0,755	0,680

- ELWT (Evaporator Leaving Water Temperature (°C))
- Table referred to Cooling Mode only
- Correction factors have to be applied at working conditions: evaporator leaving water temperature 7°C

Correction factors for water and glycol mixture

	Ethylene Glycol (%)	10%	20%	30%	40%	50%
Ethylene Glycol	Cooling Capacity	0,991	0,982	0,972	0,961	0,946
	Compressor Power Input	0,996	0,992	0,986	0,976	0,966
	Flow Rate (Δt)	1,013	1,04	1,074	1,121	1,178
	Evaporator Pressure Drop	1,070	1,129	1,181	1,263	1,308
Propylene Glycol	Cooling Capacity	0,985	0,964	0,932	0,889	0,846
	Compressor Power Input	0,993	0,983	0,969	0,948	0,929
	Flow Rate (Δt)	1,017	1,032	1,056	1,092	1,139
	Evaporator Pressure Drop	1,120	1,272	1,496	1,792	2,128

- Contact factory for water temperature out of operating limits

6 Operating limits

How to use the Correction factors proposed in the previous tables

A) Mixture Water and Glycol --- Evaporator leaving water temperature > 4°C

- depending from the type and percentage (%) of glycol filled in the circuit (see table 4.2 and 6)
- multiply the Cooling Capacity, the Compressor Power Input by the Correction factor of Table 6
- starting from this new value of Cooling Capacity, calculate the Flow Rate (l/s) and the Evaporator Pressure Drop (kPa)
- now multiply the new Flow Rate and the new Evaporator Pressure Drop by the Correction Factors of Table 6

Example:

Unit Size: **EWAD100E-SS**

Mixture: Water
 Working condition: ELWT 12/7°C – Condenser inlet air temperature 35°C
 - Cooling capacity: 101 kW (Rated conditions)
 - Power input: 38.7 kW (Rated conditions)
 - Flow rate (Δt 5°C): 4.83 l/s
 - Evaporator pressure drop: 24 kPa

Mixture: Water + Ethylene Glycol 30% (for a winter air temperature up to -15°C)
 Working condition: ELWT 12/7°C – Condenser inlet air temperature 35°C
 - Cooling capacity: $101 \times 0.972 = 98.2$ kW
 - Power input: $38.7 \times 0.986 = 38.2$ kW
 - Flow rate (Δt 5°C): 4.69 (referred to 98.2 kW) $\times 1.074 = 5.04$ l/s
 - Evaporator pressure drop: 26 (referred to 5.04 l/s) $\times 1.181 = 31$ kPa

B) Mixture Water and Glycol --- Evaporator leaving water temperature < 4°C

- depending from the type and percentage (%) of glycol filled in the circuit (see table 4.1 and 4.2 and table 6)
- depending from the evaporator leaving water temperature (see table 5)
- multiply the Cooling Capacity, the Compressor Power Input by the Correction factor of Table 5 and Table 6
- starting from this new value of Cooling Capacity, calculate the Flow Rate (l/s) and the Evaporator Pressure Drop (kPa)
- now multiply the new Flow Rate and the new Evaporator Pressure Drop by the Correction Factors of Table 6

Example:

Unit Size: **EWAD100E-SS**

Mixture: Water
 Working condition: ELWT 12/7°C – Condenser inlet air temperature 30°C
 - Cooling capacity: 346 kW (Rated conditions)
 - Power input: 35.6 kW (Rated conditions)
 - Flow rate (Δt 5°C): 5.06 l/s
 - Evaporator pressure drop: 26 kPa

Mixture: Water + Glycol 30% (for a low evaporator leaving temperature of -1/-6°C)
 Working condition: ELWT -1/-6°C – Condenser inlet air temperature 30°C
 - Cooling capacity: $106 \times 0.613 \times 0.972 = 63.2$ kW
 - Power input: $35.6 \times 0.870 \times 0.986 = 30.5$ kW
 - Flow rate (Δt 5°C): 3.02 l/s (referred to 63.2 kW) $\times 1.074 = 3.24$ l/s
 - Evaporator pressure drop: 12 kPa (referred to 3.24 l/s) $\times 1.181 = 14$ kPa

6 Operating limits

EWAD~E-

Items ^{(1) (5)}	Cooling Water			Cooled Water		Heated water ⁽²⁾				Tendency if out of criteria		
	Circulating System		Once Flow	Cooled Water		Low temperature		High temperature				
	Circulating water	Supply water ⁽⁴⁾	Flowing water	Circulating water [Below 20°C]	Supply water ⁽⁴⁾	Circulating water [20°C ~ 60°C]	Supply water ⁽⁴⁾	Circulating water [60°C ~ 80°C]	Supply water ⁽⁴⁾			
pH	at 25°C	6.5 ~ 8.2	6.0 ~ 8.0	6.0 ~ 8.0	6.0 ~ 8.0	6.0 ~ 8.0	7.0 ~ 8.0	7.0 ~ 8.0	7.0 ~ 8.0	7.0 ~ 8.0	Corrosion + Scale	
Items to be controlled:	Electrical conductivity	[mS/cm] at 25°C	Below 80	Below 30	Below 40	Below 40	Below 30	Below 30	Below 30	Below 30	Corrosion + Scale	
		[μS/cm] at 25°C	(Below 800)	(Below 300)	(Below 400)	(Below 400)	(Below 300)	(Below 300)	(Below 300)	(Below 300)	Corrosion + Scale	
	Chloride ion	[mgCl ⁻ /l]	Below 200	Below 50	Below 50	Below 50	Below 50	Below 50	Below 50	Below 50	Corrosion	
	Sulfate ion	[mgSO ₄ ²⁻ /l]	Below 200	Below 50	Below 50	Below 50	Below 50	Below 50	Below 50	Below 30	Below 30	Corrosion
	M-alkalinity (pH4.8)	[mgCaCO ₃ /l]	Below 100	Below 50	Below 50	Below 50	Below 50	Below 50	Below 50	Below 50	Below 50	Scale
	Total hardness	[mgCaCO ₃ /l]	Below 200	Below 70	Below 70	Below 70	Below 70	Below 70	Below 70	Below 70	Below 70	Scale
	Calcium hardness	[mgCaCO ₃ /l]	Below 150	Below 50	Below 50	Below 50	Below 50	Below 50	Below 50	Below 50	Below 50	Scale
	Silica ion	[mgSiO ₂ /l]	Below 50	Below 30	Below 30	Below 30	Below 30	Below 30	Below 30	Below 30	Below 30	Scale
	Iron	[mgFe/l]	Below 1.0	Below 0.3	Below 1.0	Below 1.0	Below 0.3	Below 1.0	Below 0.3	Below 1.0	Below 0.3	Corrosion + Scale
	Copper	[mgCu/l]	Below 0.3	Below 0.1	Below 1.0	Below 1.0	Below 1.0	Below 1.0	Below 0.1	Below 1.0	Below 0.1	Corrosion
Items to be referred to	Sulfite ion	[mgS ₂ -/l]	Not detectable	Not detectable	Not detectable	Not detectable	Not detectable	Not detectable	Not detectable	Not detectable	Corrosion	
	Ammonium ion	[mgNH ₄ ⁺ /l]	Below 1.0	Below 0.1	Below 1.0	Below 1.0	Below 0.1	Below 0.3	Below 0.1	Below 0.1	Below 0.1	Corrosion
	Remaining chloride	[mgCl ₂ /l]	Below 0.3	Below 0.3	Below 0.3	Below 0.3	Below 0.3	Below 0.25	Below 0.3	Below 0.1	Below 0.3	Corrosion
	Free carbide	[mgCO ₂ /l]	Below 4.0	Below 4.0	Below 4.0	Below 4.0	Below 4.0	Below 0.4	Below 4.0	Below 0.4	Below 4.0	Corrosion
	Stability index		6.0 ~ 7.0	---	---	---	---	---	---	---	---	Corrosion + Scale

- Names, definitions and units are according to JIS K 0101. Units and figures between brackets are old units published as reference only.
- In case of using heated water (more than 40°C), corrosion is generally noticeable. Especially when the iron materials is in direct contact with water without any protection shields, it is desirable to give the valid measure for corrosion. E.g. chemical measure
- In the cooling water using hermetic cooling tower, close circuit water is according to heated water standard, and scattered water is according to cooling water standard.
- Supply water is considered drink water, industrial water and ground water except for genuine water, neutral water and soft water.
- The above mentioned items are representable items in corrosion and scale cases.

Water content in cooling circuits

The cooled water distribution circuits should have minimum water content to avoid excessive compressors start and stop. In fact, each time the compressor starts up, an excessive quantity of oil goes from the compressor sump and simultaneously there is a rise in the temperature of the compressor motor's stator due to the inrush current during the start-up. To prevent damage to the compressors, Daikin has envisaged the application of a device to limit frequent stops and restarts.

During the span of one hour there will be no more than 6 starts of the compressor. The plant side should therefore ensure that the overall water content allows a more constant functioning of the unit and consequently greater environmental comfort. The minimum water content per unit should be calculated using this simplified formula:

$$\text{For 1 compressors unit} \\ M \text{ (liters)} = (0.94 \times \Delta T(^{\circ}\text{C}) + 5.87) \times P(\text{kW})$$

Where:

- M minimum water content per unit expressed in litres
- P Cooling Capacity of the unit expressed in kW
- ΔT evaporator entering / leaving water temperature difference expressed in °C

This formula is valid for:
- standard microprocessor parameters

For more accurate determination of quantity of water, it is advisable to contact the designer of the plant.

7 Standard rating

7 - 1 Cooling capacity tables

EWAD~E-SS		Condenser Inlet Air Temperature (°C)														
Size	ELWT (°C)	20		25		30		35		40		45		48		
		Cc (kW)	Pi (kW)	Cc (kW)	Pi (kW)	Cc (kW)	Pi (kW)	Cc (kW)	Pi (kW)	Cc (kW)	Pi (kW)	Cc (kW)	Pi (kW)	Cc (kW)	Pi (kW)	
100	4	106	28,9	102	31,4	97,2	34,2	92,5	37,3	87,3	40,6	81,8	44,1	78,2	46,3	
	5	109	29,3	105	31,9	100	34,7	95,3	37,7	90,1	41,1	84,6	44,6	81,0	46,9	
	6	112	29,7	108	32,3	103	35,1	98,2	38,2	92,9	41,5	87,3	45,1	83,6	47,4	
	7	115	30,1	111	32,7	106	35,6	101	38,7	95,7	42,0	90,0	45,6	86,4	47,9	
	8	118	30,5	114	33,1	109	36,0	104	39,2	98,6	42,5	92,8	46,2	88,1	47,7	
	9	121	30,9	117	33,6	112	36,5	107	39,6	101	43,0	95,6	46,7	88,4	46,5	
	10	124	31,4	120	34,1	115	37,0	110	40,1	104	43,6	98,4	47,2	89,2	45,7	
	11	128	31,8	123	34,5	118	37,5	113	40,6	107	44,1	101	47,8	89,9	45,0	
	12	131	32,3	126	35,0	121	37,9	116	41,1	110	44,6	104	48,3	91,3	44,6	
	13	134	32,7	129	35,5	124	38,4	119	41,7	113	45,1	107	48,9	91,8	43,8	
	14	138	33,2	133	36,0	128	39,0	122	42,2	116	45,7	110	49,4	92,2	43,0	
	15	141	33,7	136	36,5	131	39,5	125	42,7	119	46,2	111	48,7	93,2	42,5	
	120	4	127	34,9	122	38,0	116	41,4	110	45,2	104	49,2	97,2	53,5	92,9	56,2
		5	130	35,3	125	38,5	120	42,0	114	45,7	107	49,8	101	54,1	94,9	55,9
		6	134	35,9	129	39,1	123	42,6	117	46,3	111	50,4	104	54,8	95,5	54,5
7		137	36,4	132	39,6	127	43,1	121	46,9	114	51,0	107	55,4	96,5	53,7	
8		141	36,9	136	40,1	130	43,7	124	47,5	117	51,6	110	56,1	97,5	52,8	
9		145	37,4	139	40,7	134	44,3	127	48,1	121	52,3	114	56,7	98,4	51,8	
10		149	38,0	143	41,3	137	44,8	131	48,7	124	52,9	117	57,4	99,1	50,9	
11		152	38,5	147	41,8	141	45,4	134	49,4	128	53,6	120	58,1	101	50,4	
12		156	39,1	150	42,4	144	46,1	138	50,0	131	54,2	121	56,8	101	49,5	
13		160	39,6	154	43,0	148	46,7	142	50,6	135	54,9	122	55,9	101	48,5	
14		164	40,2	158	43,6	152	47,3	145	51,3	138	55,6	123	54,9	102	48,0	
15		168	40,8	162	44,3	156	48,0	149	52,0	142	56,3	124	54,5	103	47,5	
140		4	136	42,9	138	43,7	132	47,5	126	51,6	119	56,1	111	61,1	107	64,4
		5	140	43,6	142	44,3	136	48,0	130	52,2	123	56,8	115	61,8	110	65,2
		6	152	41,3	146	44,8	140	48,6	134	52,8	127	57,4	119	62,5	114	65,9
	7	156	41,8	150	45,4	144	49,2	138	53,4	131	58,0	123	63,2	118	66,6	
	8	160	42,4	155	45,9	148	49,8	142	54,0	135	58,7	127	63,9	122	67,4	
	9	164	42,9	159	46,5	152	50,4	146	54,7	139	59,4	131	64,7	126	68,1	
	10	169	43,5	163	47,1	157	51,0	150	55,3	143	60,1	135	65,4	129	68,9	
	11	173	44,0	167	47,6	161	51,6	154	55,9	147	60,8	139	66,1	133	69,6	
	12	178	44,6	171	48,2	165	52,2	158	56,6	151	61,5	143	66,9	135	68,7	
	13	182	45,2	176	48,9	169	52,9	162	57,3	155	62,2	147	67,7	136	67,6	
	14	187	45,8	180	49,5	174	53,5	166	58,0	159	62,9	150	68,4	137	66,4	
	15	191	46,4	185	50,1	178	54,2	171	58,7	163	63,6	155	69,2	138	65,3	
	160	4	170	45,0	163	49,0	156	53,4	149	58,1	141	63,3	132	68,8	126	72,3
		5	174	45,5	168	49,6	161	54,1	153	58,8	145	64,0	136	69,6	131	73,1
		6	179	46,1	173	50,3	166	54,7	158	59,5	150	64,7	141	70,3	135	73,9
7		184	46,8	177	50,9	170	55,4	163	60,3	154	65,5	145	71,1	139	74,7	
8		189	47,4	182	51,5	175	56,1	167	61,0	159	66,3	150	71,9	144	75,5	
9		194	48,0	187	52,2	180	56,8	172	61,7	163	67,0	154	72,7	148	76,4	
10		199	48,7	192	52,9	184	57,5	176	62,4	168	67,8	159	73,6	150	75,3	
11		204	49,3	197	53,6	189	58,2	181	63,2	173	68,6	163	74,4	151	74,1	
12		209	50,0	202	54,3	194	58,9	186	63,9	177	69,4	168	75,2	153	72,9	
13		214	50,7	207	55,0	199	59,6	191	64,7	182	70,2	172	76,1	154	71,6	
14		219	51,4	212	55,7	204	60,4	196	65,5	187	71,0	177	76,9	155	70,4	
15		225	52,1	217	56,4	209	61,2	201	66,3	191	71,8	182	77,8	157	69,8	
180		4	185	53,5	184	55,9	176	60,7	167	66,1	157	72,2	144	79,2	135	83,8
		5	190	54,3	190	56,6	181	61,4	172	66,9	162	73,0	149	80,0	140	84,7
		6	196	55,1	195	57,3	187	62,2	178	67,7	167	73,9	154	81,0	144	85,7
	7	207	53,4	200	58,0	192	62,9	183	68,5	172	74,7	158	81,9	149	86,6	
	8	213	54,1	206	58,7	198	63,7	188	69,3	177	75,6	163	82,8	154	87,6	
	9	218	54,8	211	59,4	203	64,4	194	70,1	182	76,5	168	83,8	158	88,6	
	10	224	55,5	217	60,1	208	65,2	199	70,9	187	77,5	173	84,8	163	89,6	
	11	230	56,2	222	60,8	214	66,0	204	71,7	192	78,4	178	85,8	168	90,7	
	12	236	56,9	228	61,6	219	66,7	209	72,6	197	79,3	183	86,8	172	91,7	
	13	241	57,6	234	62,3	225	67,6	214	73,4	202	80,2	188	87,8	177	92,8	
	14	247	58,4	239	63,1	230	68,4	220	74,3	207	81,1	193	88,9	179	91,5	
	15	253	59,1	245	63,9	236	69,2	225	75,2	212	82,1	197	89,9	181	90,0	
	210	4	207	54,8	206	57,4	203	63,1	197	69,4	188	76,5	176	84,6	167	90,0
		5	213	55,5	212	58,0	208	63,8	202	70,1	194	77,3	181	85,5	172	90,9
		6	218	56,3	218	58,7	214	64,5	208	70,9	199	78,1	187	86,4	177	91,8
7		224	57,0	224	59,3	220	65,2	214	71,7	205	79,0	192	87,3	182	92,8	
8		232	54,4	229	60,0	226	65,9	220	72,5	210	79,8	197	88,2	187	93,8	
9		237	55,0	235	60,7	232	66,6	225	73,2	216	80,7	202	89,1	193	94,7	
10		243	55,7	241	61,3	237	67,4	231	74,0	221	81,6	208	90,1	198	95,7	
11		249	56,3	247	62,0	243	68,1	237	74,8	227	82,4	213	91,1	203	96,7	
12		255	57,0	253	62,8	249	68,9	242	75,7	232	83,3	219	92,0	205	96,1	
13		261	57,7	259	63,5	255	69,7	248	76,5	238	84,2	224	93,0	207	94,3	
14		267	58,4	266	64,2	261	70,5	254	77,3	244	85,2	229	94,0	208	92,5	
15		274	59,1	272	65,0	267	71,3	260	78,2	249	86,1	235	95,0	210	91,7	

NOTES

Cc (cooling capacity) - Pi (unit power input) - ELWT (evaporator leaving water temperature - Δt 5°C).
Data are referred to 0,0176 m² °C/kW evaporator fouling factor

7 Standard rating

7 - 1 Cooling capacity tables

EWAD~E-SL																
Size	ELWT (°C)	Condenser Inlet Air Temperature (°C)														
		20		25		30		35		40		45		48		
		Cc (kW)	Pi (kW)	Cc (kW)	Pi (kW)	Cc (kW)	Pi (kW)	Cc (kW)	Pi (kW)	Cc (kW)	Pi (kW)	Cc (kW)	Pi (kW)	Cc (kW)	Pi (kW)	
100	4	103	28.4	99	31.1	94.6	34.0	89.7	37.2	84.4	40.6	78.6	44.2	70.0	42.4	
	5	106	28.9	102	31.6	97.3	34.5	92.4	37.7	87.0	41.1	81.2	44.8	70.9	41.6	
	6	109	29.3	105	32.1	100	35.0	95.1	38.2	89.7	41.7	83.8	45.4	71.6	40.9	
	7	112	29.8	108	32.5	103	35.5	97.9	38.8	92.4	42.2	86.5	45.9	72.2	40.1	
	8	115	30.3	111	33	106	36.0	101	39.3	95.1	42.8	88.1	45.7	73.3	39.8	
	9	118	30.7	114	33.5	109	36.6	104	39.8	97.9	43.4	89.1	45.0	73.7	39.0	
	10	121	31.2	117	34.1	112	37.1	106	40.4	101	43.9	89.9	44.2	74.1	38.1	
	11	125	31.7	120	34.6	115	37.7	109	41.0	103	44.5	90.6	43.4	75.0	37.7	
	12	128	32.2	123	35.1	118	38.2	112	41.5	106	45.1	91.3	42.6	75.8	37.3	
	13	131	32.8	126	35.7	121	38.8	115	42.1	109	45.7	91.8	41.8	75.7	36.4	
	14	134	33.3	129	36.2	124	39.3	118	42.7	112	46.3	93.0	41.4	76.4	36.0	
	15	137	33.8	132	36.8	127	39.9	121	43.3	115	47.0	93.3	40.6	76.9	35.5	
	120	4	123	35.1	118	38.4	112	42.0	106	45.9	99.7	50.1	92.0	54.0	76.5	47.2
		5	127	35.7	121	39	116	42.7	109	46.6	103	50.8	93.3	53.2	77.3	46.2
		6	130	36.3	125	39.6	119	43.3	113	47.2	106	51.5	94.5	52.3	77.8	45.3
7		133	36.9	128	40.3	122	44.0	116	47.9	109	52.2	94.9	50.9	78.9	44.8	
8		137	37.5	131	40.9	126	44.6	119	48.6	112	52.9	95.8	50.0	79.2	43.8	
9		141	38.1	135	41.5	129	45.3	122	49.3	115	53.7	97.2	49.6	80.1	43.3	
10		144	38.7	138	42.2	132	46.0	126	50.0	119	54.4	98.0	48.7	81.0	42.8	
11		148	39.3	142	42.8	136	46.6	129	50.8	122	55.2	98.5	47.7	81.8	42.3	
12		151	40	145	43.5	139	47.4	132	51.5	125	56.0	100	47.2	81.5	41.2	
13		155	40.6	149	44.2	143	48.1	136	52.2	129	56.7	100	46.2	82.0	40.7	
14		159	41.3	153	44.9	146	48.8	139	53.0	129	55.4	101	45.7	83.4	40.6	
15		163	42	156	45.6	150	49.6	143	53.8	130	54.4	101	44.7	83.8	40.0	
130		4	141	39.2	135	42.7	129	46.6	122	50.9	115	55.7	108	60.9	103	64.4
		5	145	39.7	139	43.3	133	47.3	126	51.6	119	56.4	111	61.7	105	64.0
		6	149	40.3	143	44.0	137	47.9	130	52.3	123	57.1	115	62.5	106	63.0
	7	153	40.9	147	44.6	141	48.6	134	53.0	126	57.9	119	63.3	107	62.0	
	8	157	41.5	151	45.2	145	49.2	138	53.7	130	58.6	122	64.1	109	60.9	
	9	161	42.1	155	45.8	149	49.9	142	54.4	134	59.4	126	65.0	110	59.8	
	10	165	42.7	159	46.5	153	50.6	146	55.1	138	60.2	130	65.8	110	58.7	
	11	169	43.3	163	47.1	157	51.3	150	55.9	142	61.0	133	66.6	111	57.5	
	12	174	44.0	167	47.8	161	52.0	153	56.6	146	61.8	135	65.7	113	57.0	
	13	178	44.6	172	48.5	165	52.7	157	57.4	150	62.6	136	64.6	113	55.8	
	14	182	45.3	176	49.2	169	53.4	162	58.2	154	63.4	137	63.5	114	55.2	
	15	187	46.0	180	49.9	173	54.2	166	59.0	157	64.3	138	62.3	115	54.6	
	160	4	166	44.5	159	48.7	152	53.3	144	58.2	136	63.5	126	69.3	116	69.0
		5	170	45.2	164	49.5	156	54.0	148	59.0	140	64.4	131	70.1	117	67.8
		6	175	45.9	168	50.2	161	54.8	153	59.8	144	65.2	135	71.0	119	66.7
7		180	46.6	173	50.9	165	55.6	157	60.6	149	66.1	139	71.9	120	65.5	
8		184	47.3	177	51.6	170	56.4	162	61.5	153	67.0	143	72.8	121	64.3	
9		189	48.0	182	52.4	174	57.1	166	62.3	157	67.8	147	73.2	122	63.0	
10		194	48.7	187	53.1	179	57.9	171	63.1	162	68.8	148	72.0	123	62.4	
11		199	49.5	191	53.9	184	58.8	175	64.0	166	69.7	150	70.8	124	61.1	
12		204	50.2	196	54.7	188	59.6	180	64.9	171	70.6	151	69.6	125	60.5	
13		209	51.0	201	55.5	193	60.4	184	65.7	175	71.5	152	68.3	125	59.1	
14		214	51.8	206	56.4	198	61.3	189	66.6	180	72.4	153	67.0	127	58.5	
15		219	52.6	211	57.2	203	62.2	194	67.6	184	73.4	154	65.7	128	57.8	
180		4	187	49.8	180	54.4	172	59.4	162	65.1	151	71.6	137	78.9	128	83.7
		5	193	50.5	185	55.2	177	60.3	167	66.0	156	72.5	142	79.9	132	84.8
		6	198	51.3	191	56	182	61.1	172	66.9	160	73.5	146	80.9	136	85.8
	7	203	52.0	196	56.7	188	62.0	177	67.8	165	74.5	150	82.0	140	86.2	
	8	209	52.7	201	57.5	193	62.8	182	68.8	170	75.5	155	83.1	142	84.8	
	9	214	53.5	206	58.3	198	63.7	187	69.7	175	76.5	159	84.2	142	82.5	
	10	220	54.3	212	59.1	203	64.5	192	70.7	179	77.6	164	85.3	144	81.1	
	11	225	55.1	217	60	208	65.4	197	71.6	184	78.6	168	86.4	145	79.6	
	12	231	55.9	222	60.8	213	66.3	202	72.6	189	79.7	173	87.6	148	78.9	
	13	236	56.7	228	61.7	218	67.2	207	73.6	194	80.8	177	88.8	149	77.3	
	14	242	57.5	234	62.6	224	68.2	212	74.6	198	81.9	180	88.4	150	75.7	
	15	248	58.4	239	63.4	229	69.1	217	75.6	203	83.0	181	86.0	151	75.0	
	210	4	208	51.1	204	56.7	200	62.7	192	69.4	182	77.1	168	85.7	156	90.5
		5	213	51.8	210	57.4	205	63.5	198	70.3	187	78.0	173	86.7	158	88.9
		6	219	52.5	216	58.2	211	64.4	203	71.2	192	79.0	177	87.8	160	87.2
7		225	53.2	222	59	217	65.2	209	72.1	197	80.0	182	88.9	161	85.5	
8		231	53.9	227	59.8	222	66.1	214	73.1	202	81.0	187	89.9	163	83.8	
9		236	54.7	233	60.5	228	66.9	220	74.0	208	82.0	192	91.0	165	82.9	
10		242	55.4	239	61.3	234	67.8	225	75.0	213	83.1	197	92.2	166	81.1	
11		248	56.2	245	62.2	239	68.7	231	75.9	218	84.1	201	92.5	167	80.2	
12		254	57.0	251	63.0	245	69.6	236	76.9	224	85.2	202	90.8	168	78.3	
13		260	57.8	257	63.9	251	70.5	242	77.9	229	86.3	203	89.0	169	77.4	
14		266	58.6	263	64.7	256	71.4	247	78.9	234	87.4	206	88.1	171	76.3	
15		273	59.5	269	65.6	262	72.4	253	80.0	239	88.5	207	86.3	172	75.3	

NOTES

Cc (cooling capacity) - Pi (unit power input) – ELWT (evaporator leaving water temperature – Δt 5°C).
Data are referred to 0,0176 m² °C/kW evaporator fouling factor

7 Standard rating

7 - 1 Cooling capacity tables

EWAD~E-SS

Size	ELWT (°C)	Condenser Inlet Air Temperature (°C)														
		20		25		30		35		40		45		48		
		Cc (kW)	Pi (kW)	Cc (kW)	Pi (kW)	Cc (kW)	Pi (kW)	Cc (kW)	Pi (kW)	Cc (kW)	Pi (kW)	Cc (kW)	Pi (kW)	Cc (kW)	Pi (kW)	
260	4	262	67,0	256	71,5	245	77,2	233	83,8	220	91,6	204	101	193	107	
	5	270	68,0	264	72,4	253	78,2	240	84,8	227	92,5	211	101	200	108	
	6	278	69,0	272	73,4	261	79,1	248	85,7	234	93,4	218	102	207	108	
	7	286	70,0	280	74,4	269	80,1	256	86,7	242	94,3	225	103	214	109	
	8	294	71,1	288	75,4	277	81,2	264	87,7	249	95,3	232	104	221	110	
	9	302	72,2	296	76,4	285	82,2	272	88,8	257	96,4	239	105	228	111	
	10	316	72,2	305	77,4	293	83,2	280	89,8	265	97,4	247	106	235	112	
	11	325	73,2	313	78,5	301	84,3	287	90,9	272	98,5	254	107	242	113	
	12	333	74,3	321	79,5	309	85,3	295	92,0	280	99,6	262	108	249	114	
	13	342	75,4	330	80,6	317	86,4	303	93,1	288	101	270	110	257	115	
	14	351	76,5	339	81,8	326	87,6	312	94,2	296	102	277	111	265	117	
	15	360	77,7	348	82,9	334	88,7	320	95,4	303	103	285	112	272	118	
	310	4	322	84,9	309	91,6	296	98,6	280	106	263	114	243	123	230	128
		5	331	86,1	318	92,9	305	100	289	108	271	116	251	124	237	130
		6	341	87,4	327	94,2	313	101	298	109	280	117	259	126	245	132
7		350	88,6	337	95,6	322	103	307	111	288	119	267	128	252	134	
8		359	89,9	346	96,9	331	104	315	112	297	121	275	130	260	136	
9		369	91,2	355	98,3	340	106	324	114	305	123	283	132	268	138	
10		379	92,5	365	99,7	349	107	333	116	314	124	291	134	269	137	
11		389	93,9	374	101	359	109	341	117	322	126	300	136	270	134	
12		399	95,2	384	103	368	110	350	119	331	128	308	138	273	133	
13		409	96,6	394	104	377	112	359	121	339	130	316	140	275	131	
14		419	98,0	404	106	387	114	369	122	348	132	324	142	277	130	
15		430	99,4	414	107	397	115	378	124	357	134	332	144	278	128	
360		4	380	101	365	109	349	118	330	127	309	136	285	147	268	154
		5	391	103	375	111	359	120	340	129	319	139	294	149	277	156
		6	401	104	386	113	369	121	350	131	328	141	303	152	286	159
	7	412	106	396	114	379	123	360	133	338	143	312	154	291	159	
	8	424	108	407	116	390	125	370	135	348	145	321	156	294	158	
	9	435	109	418	118	400	127	380	137	358	147	331	159	296	156	
	10	446	111	429	120	411	129	390	139	367	150	340	161	298	154	
	11	458	112	440	121	422	131	401	141	377	152	350	164	299	151	
	12	469	114	452	123	432	133	411	143	387	154	359	166	301	149	
	13	481	116	463	125	443	135	421	145	397	156	366	168	305	148	
	14	493	118	475	127	454	137	432	147	407	159	370	167	307	145	
	15	505	119	486	129	466	139	443	149	417	161	370	164	308	142	
	410	4	417	108	407	118	396	128	382	139	363	151	339	165	297	156
		5	428	110	418	120	407	130	392	141	373	154	348	168	299	153
		6	439	111	429	122	417	132	403	144	383	156	358	170	300	151
7		450	113	440	123	428	134	413	146	393	158	365	171	301	148	
8		462	115	451	125	439	136	424	148	404	161	366	167	305	147	
9		473	117	462	127	450	138	434	150	414	163	368	165	305	145	
10		485	118	474	129	461	140	445	152	424	166	372	164	307	143	
11		497	120	485	131	472	142	455	155	434	168	374	161	310	142	
12		509	122	497	133	483	144	466	157	444	170	375	159	312	141	
13		521	124	509	135	495	147	477	159	454	173	379	157	314	139	
14		533	126	521	137	506	149	488	161	464	175	379	155	315	138	
15		546	128	533	139	518	151	499	164	475	178	382	153	317	136	

NOTES

Cc (cooling capacity) - Pi (unit power input) - ELWT (evaporator leaving water temperature - Δt 5°C).
 Data are referred to 0,0176 m² °C/kW evaporator fouling factor

7 Standard rating

7 - 1 Cooling capacity tables

EWAD~E-SL																
Size	ELWT (°C)	Condenser Inlet Air Temperature (°C)														
		20		25		30		35		40		45		48		
		Cc (kW)	Pi (kW)	Cc (kW)	Pi (kW)	Cc (kW)	Pi (kW)	Cc (kW)	Pi (kW)	Cc (kW)	Pi (kW)	Cc (kW)	Pi (kW)	Cc (kW)	Pi (kW)	
250	4	262	62,9	251	68,3	239	74,3	227	81,4	213	89,6	197	99	185	106	
	5	270	63,9	259	69,3	247	75,3	234	82,4	220	90,5	203	100	191	106	
	6	278	65,0	267	70,3	255	76,4	242	83,4	227	91,6	210	101	198	107	
	7	286	66,0	275	71,4	263	77,5	249	84,5	234	92,6	216	102	204	108	
	8	293	67,0	282	72,5	270	78,6	257	85,6	241	93,7	223	103	211	109	
	9	302	68,1	290	73,5	278	79,7	264	86,7	248	94,8	230	104	218	110	
	10	310	69,2	298	74,7	286	80,8	272	87,9	256	96,0	237	105	224	112	
	11	318	70,3	306	75,8	294	82,0	280	89,1	263	97,2	244	106	228	111	
	12	327	71,5	315	77,0	302	83,1	287	90,2	271	98,4	251	108	229	109	
	13	335	72,7	323	78,1	310	84,3	295	91,4	278	100	258	109	231	107	
	14	344	73,9	331	79,4	318	85,6	303	92,7	286	101	266	110	233	105	
	15	352	75,1	340	80,6	326	86,8	310	94,0	293	102	273	112	235	103	
	300	4	315	83,0	302	89,7	287	96,8	271	104	253	113	232	122	213	125
		5	324	84,3	310	91,2	296	99	279	106	260	115	239	124	215	123
		6	333	85,7	319	92,7	305	100	288	108	268	117	246	126	217	122
7		342	87,1	328	94,2	313	102	296	110	276	118	253	128	218	120	
8		351	88,6	337	95,8	321	103	304	112	284	120	261	130	220	118	
9		360	90,0	346	97,3	330	105	313	114	292	123	268	132	222	117	
10		369	91,5	355	98,9	339	107	321	115	300	125	270	131	224	115	
11		379	93,1	364	101	347	109	329	117	308	127	272	130	225	112	
12		389	94,6	373	102	356	110	337	119	316	129	273	127	228	111	
13		398	96,2	382	104	365	112	346	121	324	131	275	126	229	109	
14		408	97,8	392	106	374	114	354	123	332	133	277	124	231	108	
15		418	99,4	401	107	383	116	363	125	340	135	279	122	233	106	
350		4	370	101	354	109	337	118	317	127	294	137	268	148	230	139
		5	380	103	364	111	347	120	326	129	303	140	276	151	232	138
		6	390	105	374	113	356	122	336	132	312	142	284	153	235	136
	7	401	106	384	115	366	124	345	134	321	145	288	153	237	133	
	8	411	108	394	117	376	126	355	136	330	147	289	151	238	131	
	9	422	110	405	119	385	128	364	139	339	150	290	148	242	130	
	10	433	112	415	121	395	131	373	141	348	152	293	146	243	127	
	11	444	114	425	123	405	133	383	143	357	155	295	144	246	126	
	12	455	116	436	125	415	135	392	146	366	157	297	142	246	122	
	13	466	118	447	127	425	137	402	148	375	160	299	139	249	121	
	14	477	120	457	129	436	140	411	151	384	163	303	138	251	119	
	15	488	122	468	132	446	142	421	153	391	164	304	135	253	117	
	400	4	409	110	399	120	385	131	368	142	346	156	289	149	239	132
		5	420	112	409	122	396	133	378	145	355	158	293	148	242	130
		6	431	114	420	124	406	135	388	148	364	161	294	146	244	128
7		442	116	430	126	416	138	398	150	373	164	295	143	246	126	
8		453	118	441	128	427	140	408	153	383	166	298	141	247	124	
9		464	120	452	131	437	142	417	155	387	167	301	140	249	121	
10		475	122	463	133	447	145	427	158	390	165	300	136	250	119	
11		487	124	474	135	458	147	437	160	392	163	303	134	254	118	
12		498	126	485	138	468	150	447	163	393	161	305	132	254	116	
13		510	128	496	140	478	152	456	166	395	158	306	130	254	113	
14		522	131	507	142	489	155	466	169	399	157	311	130	258	112	
15		533	133	518	145	500	158	476	171	399	154	312	128	261	112	

NOTES

Cc (cooling capacity) - Pi (unit power input) – ELWT (evaporator leaving water temperature – Δt 5°C).
 Data are referred to 0,0176 m² °C/kW evaporator fouling factor

8 Evaporator pressure drop

EWAD~E-SS

	100	120	140	160	180	210	260	310	360	410
Cooling Capacity (kW)	101	121	138	163	183	214	256	307	360	413
Water Flow (l/s)	4,83	5,76	6,58	7,77	8,74	10,22	12,22	14,65	17,21	19,74
Pressure Drops (kPa)	24	25	24	24	22	21	48	48	48	45

Water flow and pressure drop referred to nominal condition: evaporator water in/out: 12/7°C – condenser air inlet: 35°C

EWAD~E-SL

	100	120	130	160	180	210	250	300	350	400
Cooling Capacity (kW)	97,9	116	134	157	177	209	249	296	345	398
Water Flow (l/s)	4,68	5,54	6,40	7,51	8,47	9,97	11,90	14,15	16,50	19,01
Pressure Drops (kPa)	23	23	23	23	21	20	46	45	44	42

Water flow and pressure drop referred to nominal condition: evaporator water in/out: 12/7°C – condenser air inlet: 35°C

EPD_1-2_Rev.00_1

To determine the pressure drop for different versions or at different working conditions, please refer to the following formula:

$$PD_2 \text{ (kPa)} = PD_1 \text{ (kPa)} \times \left(\frac{Q_2 \text{ (l/s)}}{Q_1 \text{ (l/s)}} \right)^{1.8}$$

where:

- PD_2 Pressure drop to be determinate (kPa)
- PD_1 Pressure drop at nominal condition (kPa)
- Q_2 water flow at new working condition (l/s)
- Q_1 water flow at nominal condition (l/s)

How to use the formula: Example

The unit EWAD100E-SS has been selected for working at the following conditions:

- evaporator water in/out : 11/6°C
 - condenser air inlet: 30°C
- The cooling capacity at these working conditions is: 103 kW (Rated conditions)
 The water flow at these working conditions is: 4.92 l/s (Rated conditions)

The unit EWAD100E-SS at nominal working conditions has the following data:

- evaporator water in/out : 12/7°C
 - condenser air inlet: 35°C
- The cooling capacity at these working conditions is: 101 kW
 The water flow at these working conditions is: 4.83 l/s
 The pressure drop at these working conditions is: 24 kPa

The pressure drop at the selected working condition will be:

$$PD_2 \text{ (kPa)} = 24 \text{ (kPa)} \times \left(\frac{4.92 \text{ (l/s)}}{4.83 \text{ (l/s)}} \right)^{1.8}$$

$$PD_2 \text{ (kPa)} = 25 \text{ (kPa)}$$

NOTE - Important

If the calculated evaporator water pressure drop is below 10 kPa or above 100 kPa, please contact the factory for dedicated evaporator.

EPD_1-2_Rev.00_2

9 Options

Partial Heat Recovery pressure drops

EWAD-E-SS / SL

Size EWAD-E-SS	100	120	140	160	180	210	260	310	360	410
Size EWAD-E-SL	100	120	130	160	180	210	250	300	350	400
Heating Capacity (kW)	44,2	52,9	60,8	70	79	92	109	133	134	134
Water Flow (l/s)	2,11	2,53	2,90	3,37	3,78	4,41	5,22	6,33	6,41	6,39
Heat Recovery Pressure Drops (kPa)	5	6	6	7	7	8	4	5	4	3

NOTES

Water flow and pressure drop referred to nominal condition: evaporator water in/out: 12/7°C – condenser air inlet 35°C – water heat recovery in/out 40/45°C

Total Heat Recovery pressure drops

EWAD-E-SS / SL

Size EWAD-E-SS	100	120	140	160	180	210	260	310	360	410
Size EWAD-E-SL	100	120	130	160	180	210	250	300	350	400
Heating Capacity (kW)	110	131	151	175	196	230	273	330	344	343
Water Flow (l/s)	5,24	6,27	7,21	8,36	9,38	10,99	13,02	15,78	16,44	16,39
Heat Recovery Pressure Drops (kPa)	26	29	33	34	36	39	23	27	21	18

NOTES

Water flow and pressure drop referred to nominal condition: evaporator water in/out: 12/7°C – condenser air inlet 35°C – water heat recovery in/out 40/45°C

OPT_1-2-3-4-5-6-7_Rev.01_1-2

Total and Partial Heat Recovery Pressure Drops

To determine the pressure drop for different versions or at different working condition, please refer to the following formula:

$$PD_2 \text{ (kPa)} = PD_1 \text{ (kPa)} \times \left(\frac{Q_2 \text{ (l/s)}}{Q_1 \text{ (l/s)}} \right)^{1.80}$$

where:

- PD_2 Pressure drop to be determinate (kPa)
- PD_1 Pressure drop at nominal condition (kPa)
- Q_2 water flow at new working condition (l/s)
- Q_1 water flow at nominal condition (l/s)

How to use the formula: Example

The unit EWAD100E-SS has been selected for working at the following conditions:

- Total heat recovery leaving water temperature 40/50°C
- The heating capacity at these working conditions is: 106 kW
- The water flow at these working conditions is: 2.53 l/s

The unit EWAD100E-SS at nominal working conditions has the following data:

- Total heat recovery leaving water temperature 40/45°C
- condenser air inlet: 35°C
- The heating capacity at these working conditions is: 110 kW
- The water flow at these working conditions is: 5.24 l/s
- The pressure drop at these working conditions is: 26 kPa

The pressure drop at the selected working condition will be:

$$PD_2 \text{ (kPa)} = 26 \text{ (kPa)} \times \left(\frac{2.53 \text{ (l/s)}}{5.24 \text{ (l/s)}} \right)^{1.80}$$

$$PD_2 \text{ (kPa)} = 7 \text{ (kPa)}$$

OPT_1-2-3-4-5-6-7_Rev.01_3

9 Options

Total heat recovery ratings

EWC/LWC	Model EWAD-E-SS	Model EWAD-E-SL	Cc (kW)	Pi (kW)	Hc (kW)	% Hc	EER Hc
40/45	100	100	92,3	36,6	110	85%	5,52
	120	120	110	44,4	131	85%	5,44
	140	130	128	49,4	151	85%	5,65
	160	160	149	57,1	175	85%	5,67
	180	180	166	65,2	196	85%	5,55
	210	210	197	73,2	230	85%	5,84
	260	250	233	87,6	273	85%	5,77
	310	300	278	110	330	85%	5,51
	360	350	326	132	344	75%	5,06
	410	400	380	148	343	65%	4,88
40/50	100	100	88,0	37,0	106	85%	5,25
	120	120	105	44,8	127	85%	5,18
	140	130	122	49,9	146	85%	5,38
	160	160	142	57,7	170	85%	5,40
	180	180	158	65,9	190	85%	5,29
	210	210	188	74,0	223	85%	5,56
	260	250	222	88,4	264	85%	5,50
	310	300	265	111	320	85%	5,25
	360	350	311	134	334	75%	4,82
	410	400	362	150	332	65%	4,64
45/55	100	100	88,0	37,4	75,3	60%	4,36
	120	120	105	45,3	90,1	60%	4,30
	140	130	122	50,5	104	60%	4,47
	160	160	142	58,3	120	60%	4,49
	180	180	158	66,6	135	60%	4,39
	210	210	188	74,7	158	60%	4,63
	260	250	222	89,3	187	60%	4,58
	310	300	265	113	227	60%	4,37
	360	350	311	135	223	50%	3,96
	410	400	362	151	221	43%	3,86

Partial heat recovery ratings

50/60	100	100	88,0	38,2	44,2	35%	3,47
	120	120	105	46,3	52,9	35%	3,41
	140	130	122	51,5	60,8	35%	3,55
	160	160	142	59,5	70,4	35%	3,57
	180	180	158	67,9	79,1	35%	3,49
	210	210	188	75,4	92,3	35%	3,72
	260	250	222	90,1	109	35%	3,68
	310	300	265	114	133	35%	3,50
	360	350	311	136	134	30%	3,27
	410	400	362	152	134	26%	3,25

NOTES

- Cc (cooling capacity)
- Pi (unit power input)
- Hc (heating heat recovery capacity)
- %Hc (percentage heat recovered)
- EER Hc (coefficient of performance during heat recovery = (cooling+ heating capacity) / power input)
- EWC (Entering water heat recovery condenser)
- LWC (Leaving water heat recovery condenser)

Data are referred to:

- LWE (Leaving water evaporator) = 7°C
- Same evaporator flow as for nominal cooling operation
- Condenser Inlet Air Temperature = 35°C
- 0,0176 m² °C/kW evaporator fouling factor

9 Options

EWAD~E-

Single Pump (2 poles) - Low Available external static pressure

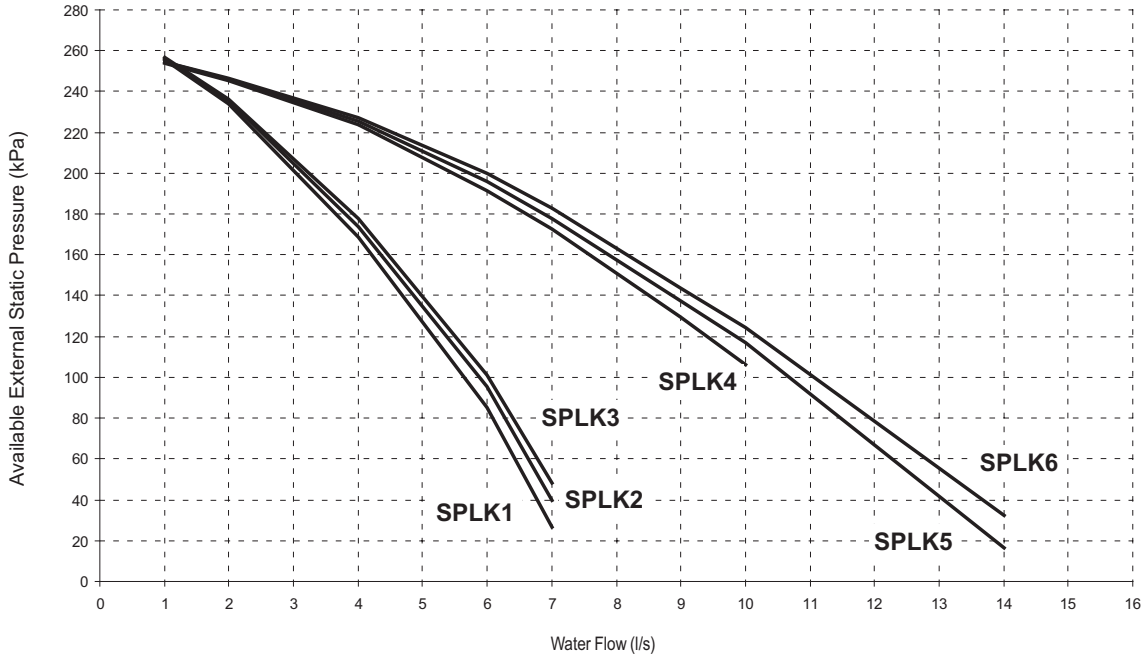

NOTE

When using mixture of water and glycol please contact the factory as above specification can change

Single Pump (2 poles) - Low Available external static pressure

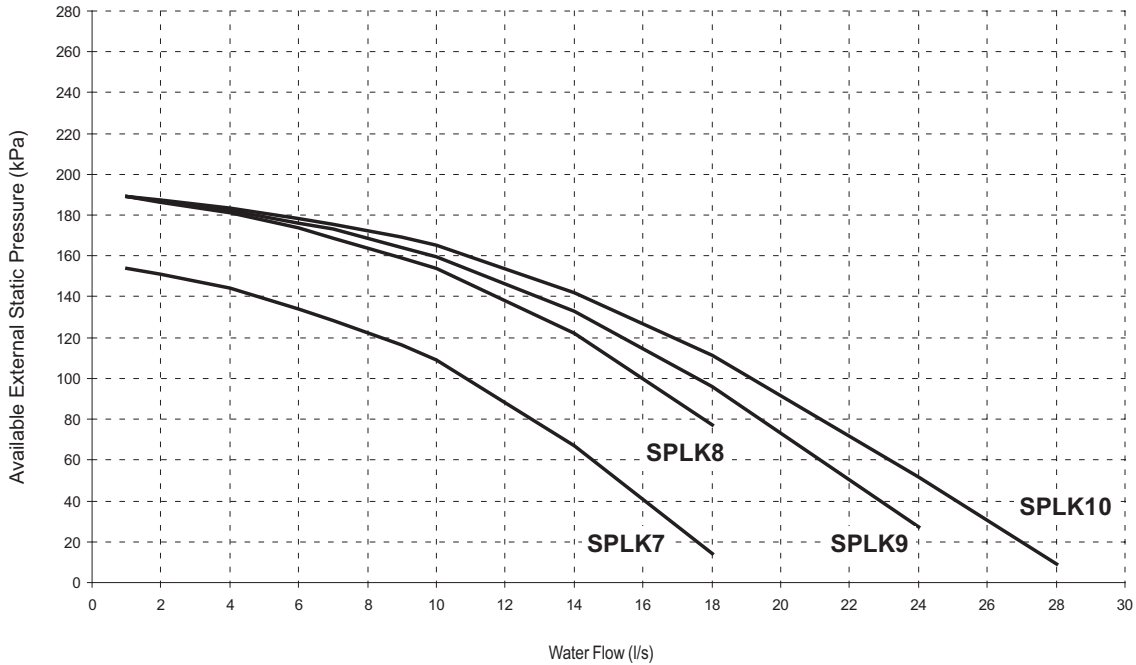

NOTE

When using mixture of water and glycol please contact the factory as above specification can change

Pump Kit	SPLK1	SPLK2	SPLK3	SPLK4	SPLK5	SPLK6	SPLK7	SPLK8	SPLK9	SPLK10
Size EWAD~E-SS	100	120	140	160	180	210	260	310	360	410
Size EWAD~E-SL	100	120	130	160	180	210	250	300	350	400

9 Options

EWAD~E-

Single Pump (2 poles) - High Available external static pressure

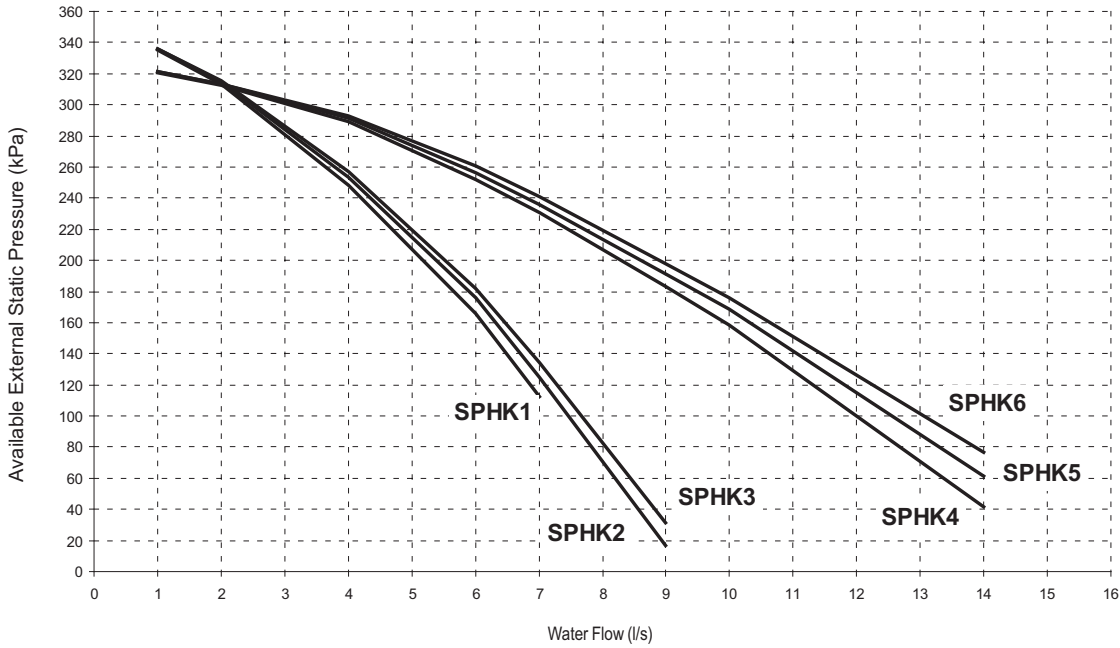

NOTE

When using mixture of water and glycol please contact the factory as above specification can change

Single Pump (2 poles) - High Available external static pressure

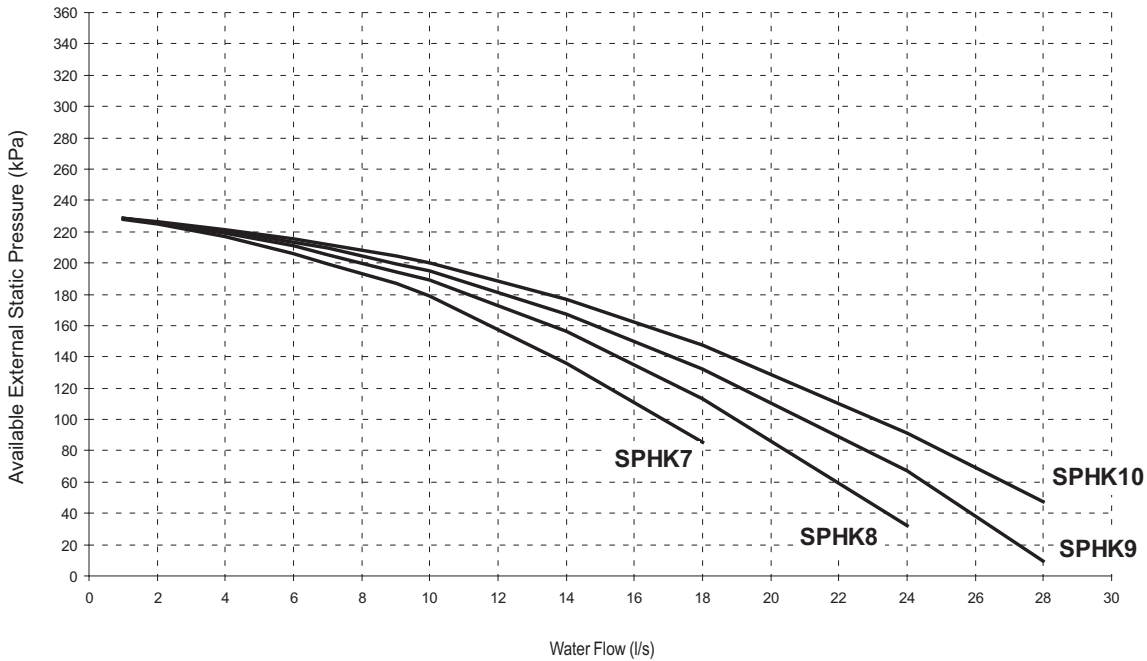

NOTE

When using mixture of water and glycol please contact the factory as above specification can change

Pump Kit	SPHK1	SPHK2	SPHK3	SPHK4	SPHK5	SPHK6	SPHK7	SPHK8	SPHK9	SPHK10
Size EWAD-E-SS	100	120	140	160	180	210	260	310	360	410
Size EWAD-E-SL	100	120	130	160	180	210	250	300	350	400

OPT_1-2-3-4-5-6-7_Rev.01_6b

9 Options

EWAD~E-

Twin Pump (2 poles) - Low Available external static pressure

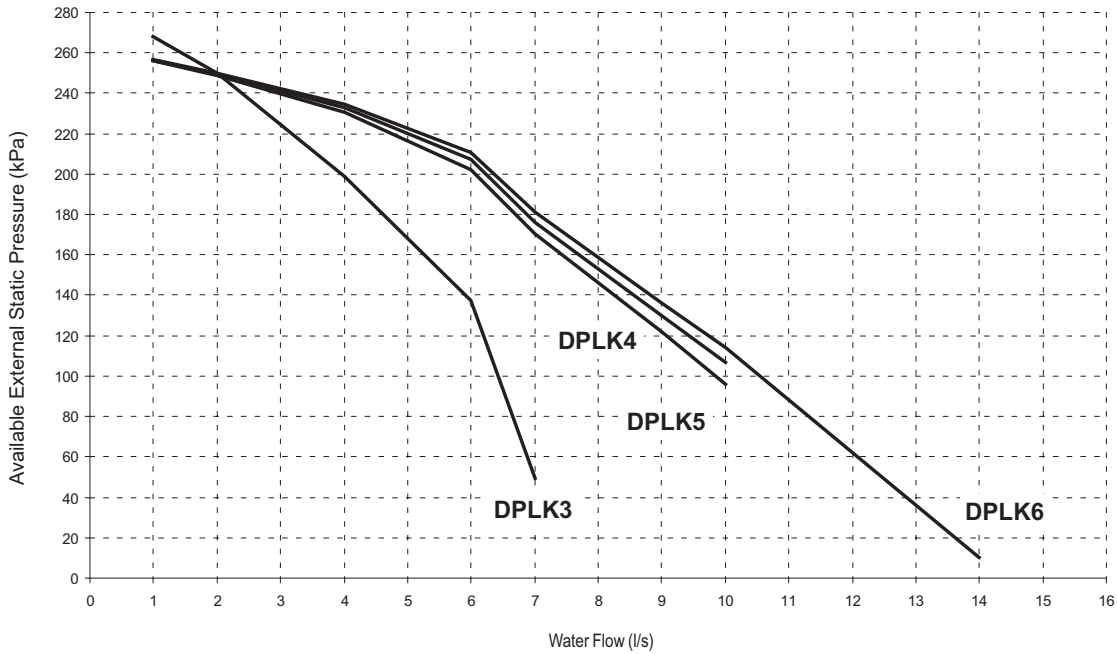

NOTE

When using mixture of water and glycol please contact the factory as above specification can change

Twin Pump (2 poles) - Low Available external static pressure

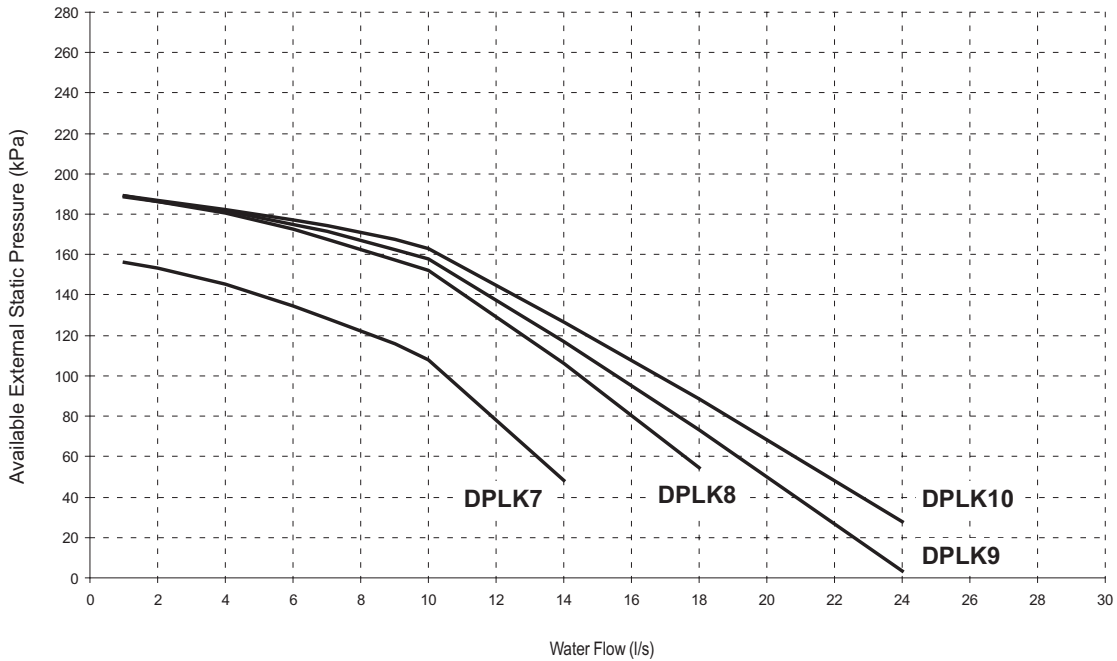

NOTE

When using mixture of water and glycol please contact the factory as above specification can change

Pump Kit	DPLK3	DPLK4	DPLK5	DPLK6	DPLK7	DPLK8	DPLK9	DPLK10
Size EWAD~E-SS	140	160	180	210	260	310	360	410
Size EWAD~E-SL	130	160	180	210	250	300	350	400

9 Options

EWAD~E-

Twin Pump (2 poles) - High Available external static pressure

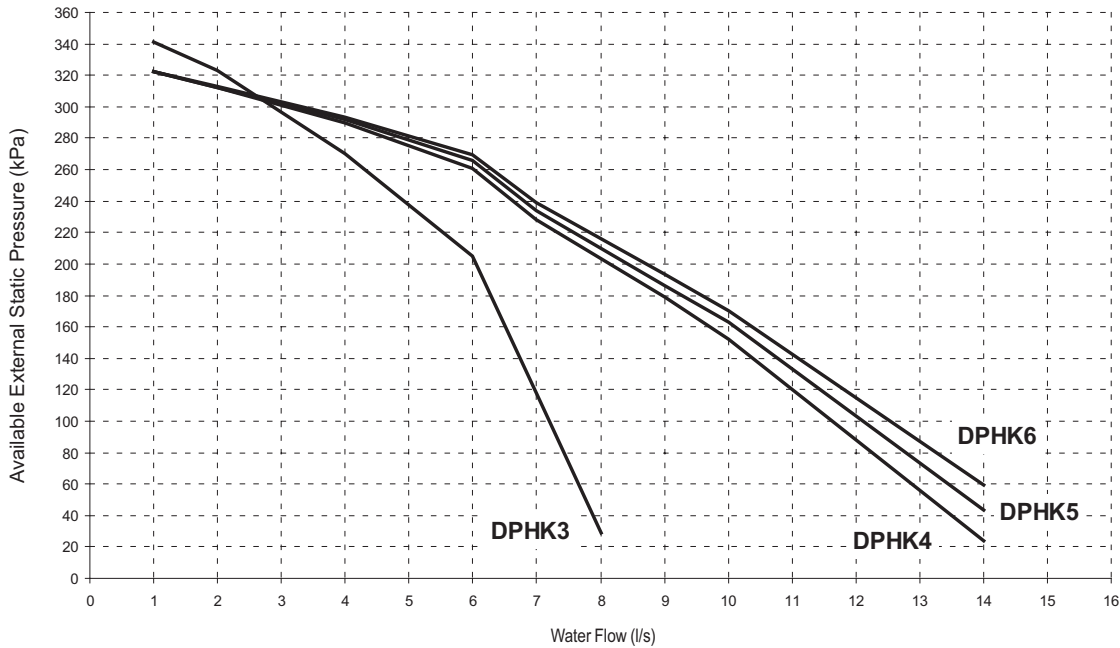

NOTE

When using mixture of water and glycol please contact the factory as above specification can change

Twin Pump (2 poles) - High Available external static pressure

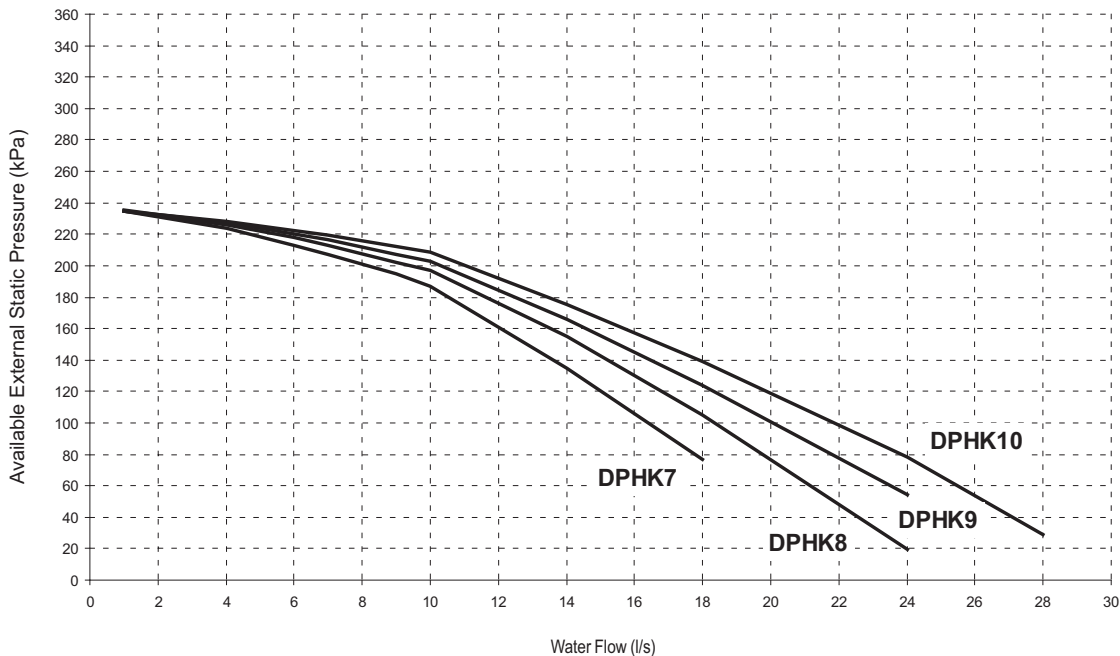

NOTE

When using mixture of water and glycol please contact the factory as above specification can change

Pump Kit	DPHK3	DPHK4	DPHK5	DPHK6	DPHK7	DPHK8	DPHK9	DPHK10
Size EWAD-E-SS	140	160	180	210	260	310	360	410
Size EWAD-E-SL	130	160	180	210	250	300	350	400

9 Options

EWAD~E- Water Pump Kit - Technical Information

		Pump Motor Power (kW)	Pump Motor Current (A)	Power supply (V-ph-Hz)	PN	Motor Protection	Insulation (Class)	Working Temp. (°C)	
Single Pump - Low Lifting	SPLK 1	1,5	3,4	400V-3ph-50hz	10	IP55	Class F	-10 ÷ 130	
	SPLK 2	1,5	3,4	400V-3ph-50hz	10	IP55	Class F	-10 ÷ 130	
	SPLK 3	1,5	3,4	400V-3ph-50hz	10	IP55	Class F	-10 ÷ 130	
	SPLK 4	2,2	5,0	400V-3ph-50hz	10	IP55	Class F	-10 ÷ 130	
	SPLK 5	2,2	5,0	400V-3ph-50hz	10	IP55	Class F	-10 ÷ 130	
	SPLK 6	2,2	5,0	400V-3ph-50hz	10	IP55	Class F	-10 ÷ 130	
	SPLK 7	3,0	6,0	400V-3ph-50hz	10	IP55	Class F	-10 ÷ 130	
	SPLK 8	4,0	8,1	400V-3ph-50hz	10	IP55	Class F	-10 ÷ 130	
	SPLK 9	4,0	8,1	400V-3ph-50hz	10	IP55	Class F	-10 ÷ 130	
	SPLK 10	4,0	8,1	400V-3ph-50hz	10	IP55	Class F	-10 ÷ 130	
Single Pump - High Lifting	SPHK 1	2,2	5,0	400V-3ph-50hz	10	IP55	Class F	-10 ÷ 130	
	SPHK 2	2,2	5,0	400V-3ph-50hz	10	IP55	Class F	-10 ÷ 130	
	SPHK 3	2,2	5,0	400V-3ph-50hz	10	IP55	Class F	-10 ÷ 130	
	SPHK 4	3,0	6,0	400V-3ph-50hz	10	IP55	Class F	-10 ÷ 130	
	SPHK 5	3,0	6,0	400V-3ph-50hz	10	IP55	Class F	-10 ÷ 130	
	SPHK 6	3,0	6,0	400V-3ph-50hz	10	IP55	Class F	-10 ÷ 130	
	SPHK 7	5,5	10,1	400V-3ph-50hz	10	IP55	Class F	-10 ÷ 130	
	SPHK 8	5,5	10,1	400V-3ph-50hz	10	IP55	Class F	-10 ÷ 130	
	SPHK 9	5,5	10,1	400V-3ph-50hz	10	IP55	Class F	-10 ÷ 130	
	SPHK 10	5,5	10,1	400V-3ph-50hz	10	IP55	Class F	-10 ÷ 130	
Twin Pump - low Lifting	DPLK 3	1,5	3,4	400V-3ph-50hz	10	IP55	Class F	-10 ÷ 130	
	DPLK 4	2,2	5,0	400V-3ph-50hz	10	IP55	Class F	-10 ÷ 130	
	DPLK 5	2,2	5,0	400V-3ph-50hz	10	IP55	Class F	-10 ÷ 130	
	DPLK 6	2,2	5,0	400V-3ph-50hz	10	IP55	Class F	-10 ÷ 130	
	DPLK 7	3,0	6,0	400V-3ph-50hz	10	IP55	Class F	-10 ÷ 130	
	DPLK 8	4,0	8,1	400V-3ph-50hz	10	IP55	Class F	-10 ÷ 130	
	DPLK 9	4,0	8,1	400V-3ph-50hz	10	IP55	Class F	-10 ÷ 130	
	DPLK 10	4,0	8,1	400V-3ph-50hz	10	IP55	Class F	-10 ÷ 130	
	Twin Pump - High Lifting	DPHK 3	2,2	5,0	400V-3ph-50hz	10	IP55	Class F	-10 ÷ 130
		DPHK 4	3,0	6,0	400V-3ph-50hz	10	IP55	Class F	-10 ÷ 130
DPHK 5		3,0	6,0	400V-3ph-50hz	10	IP55	Class F	-10 ÷ 130	
DPHK 6		3,0	6,0	400V-3ph-50hz	10	IP55	Class F	-10 ÷ 130	
DPHK 7		5,5	10,1	400V-3ph-50hz	10	IP55	Class F	-10 ÷ 130	
DPHK 8		5,5	10,1	400V-3ph-50hz	10	IP55	Class F	-10 ÷ 130	
DPHK 9		5,5	10,1	400V-3ph-50hz	10	IP55	Class F	-10 ÷ 130	
DPHK 10		5,5	10,1	400V-3ph-50hz	10	IP55	Class F	-10 ÷ 130	

NOTE

when using mixture of water and glycol please contact the factory as above specification can change

10 Dimensions

EWAD100-210E-SS
EWAD100-210E-SL

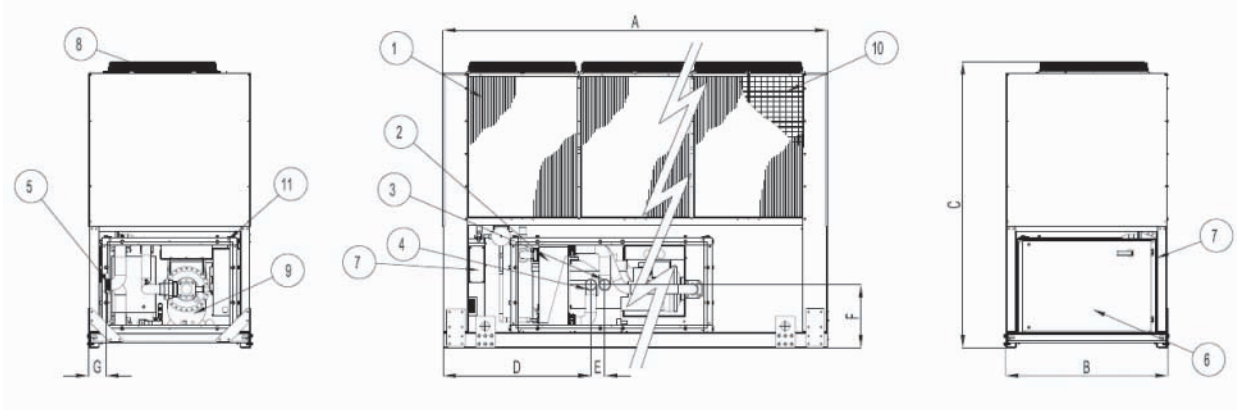

Size		Dimensions							
E-SS	E-SL	A	B	C	D	E	F	G	Fans
100	100	2165	1292	2273	1175	112	501	139	2
120	120	2165	1292	2273	1175	112	501	139	2
140	130	3065	1292	2273	1175	112	501	139	3
160	160	3065	1292	2273	1175	112	501	139	3
180	180	3965	1292	2273	1175	112	501	139	4
210	210	3965	1292	2273	1175	112	501	139	4

LEGEND

- 1 Air heat exchanger (condenser)
- 2 Water heat exchanger (evaporator)
- 3 Evaporator water inlet
- 4 Evaporator water outlet
- 5 Evaporator connections
- 6 Electrical control panel
- 7 Slot for power and control connection
- 8 Fan
- 9 Compressor
- 10 Coil protection guards (optional)
- 11 Compressor sound enclosure (optional)

DMN_1-2_Rev.00_1

10 Dimensions

EWAD260-410E-SS
EWAD250-400E-SL

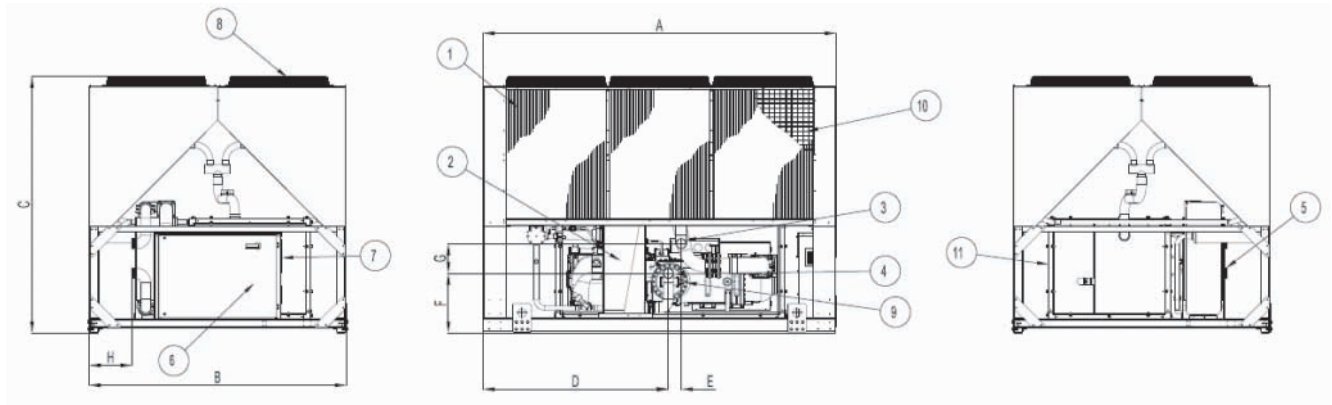

Size		Dimensions								
E-SS	E-SL	A	B	C	D	E	F	G	H	Fans
260	250	3070	2236	2223	1612	112	515	257	376	6
310	300	3070	2236	2223	1612	112	515	257	376	6
360	350	3070	2236	2223	1612	112	515	257	376	6
410	400	3070	2236	2223	1612	112	515	257	376	6

LEGEND

- 1 Air heat exchanger (condenser)
- 2 Water heat exchanger (evaporator)
- 3 Evaporator water inlet
- 4 Evaporator water outlet
- 5 Evaporator connections
- 6 Electrical control panel
- 7 Slot for power and control connection
- 8 Fan
- 9 Compressor
- 10 Coil protection guards (optional)
- 11 Compressor sound enclosure (optional)

11 Installation notes

Warning

Installation and maintenance of the unit must be performed only by qualified personnel who have knowledge with local codes and regulations, and experience with this type of equipment. Must be avoided the unit installation in places that could be considered dangerous for all the maintenance operations.

Handling

Care should be taken to avoid rough handling or shock due to dropping the unit. Do not push or pull the unit from anything other than the base frame. Never allow the unit to fall during unloading or moving as this may result in serious damage. To lift the unit, rings are provided in the base frame of the unit. Spreader bar and cables should be arranged to prevent damage to the condenser coil or unit cabinet.

Location

The units are produced for outside installation on roofs, floors or below ground level on condition that the area is free from obstacles for the passage of the condenser air. The unit should be positioned on solid foundations and perfectly level; in the case of installation on roofs or floors, it may be advisable to arrange the use of suitable weight distribution beams. When the units are installed on the ground, a concrete base at least 250 mm wider and longer than the unit's footprint should be laid. Furthermore, this base should withstand the unit weight mentioned in the technical data table.

Space requirements

The units are air-cooled, then it is important to respect the minimum distances which guarantee the best ventilation of the condenser coils. Limitations of space reducing the air flow could cause significant reductions in cooling capacity and an increase in electricity consumption.

To determinate unit placement, careful consideration must be given to assure a sufficient air flow across the condenser heat transfer surface. Two conditions must be avoided to achieve the best performance: warm air recirculation and coil starvation.

Both these conditions cause an increase of condensing pressures that result in reductions in unit efficiency and capacity.

Moreover the unique microprocessor has the ability to calculate the operating environment of the air cooled chiller and the capacity to optimize its performance staying on-line during abnormal conditions.

Each side of the unit must be accessible after installation for periodic service. Fig.1 shows you minimum recommended clearance requirements.

Vertical condenser air discharge must be unobstructed because the unit would have its capacity and efficiency significantly reduced.

If the units are positioned in places surrounded by walls or obstacles of the same height as the units, the units should be at least 2500 mm from obstacles (fig.3). In the event the obstacles are higher than the units, the units should be at least 3000 mm from the obstacle (fig.2). Units installed closer than the minimum recommended distance to a wall or other vertical riser may experience a combination of coil starvation and warm air recirculation, thus causing reduction in unit capacity and efficiency reductions. The microprocessor control is proactive in response "of design condition". In the case of single or compounded influences restricting airflow to the unit, the microprocessor will act to keep the compressor(s) running (at reduced capacity) rather than allowing a shut-off on high discharge pressure.

When two or more units are positioned side by side it is recommended that the condenser coils are at least 3600 mm distance from one another (fig.4); strong wind could be the cause of air warm recirculation.

For other installation solutions, consult our technicians.

11 Installation notes

The above recommended information are representative of general installation. A specific evaluation should be done by contractor depending on the case.

Minimum recommended installation clearances.

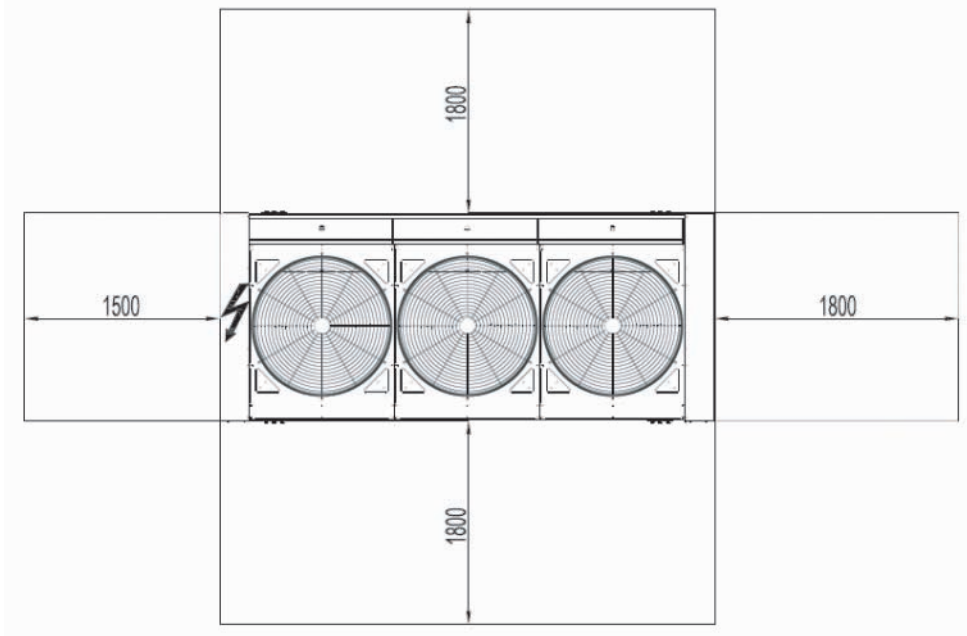

Fig. 1

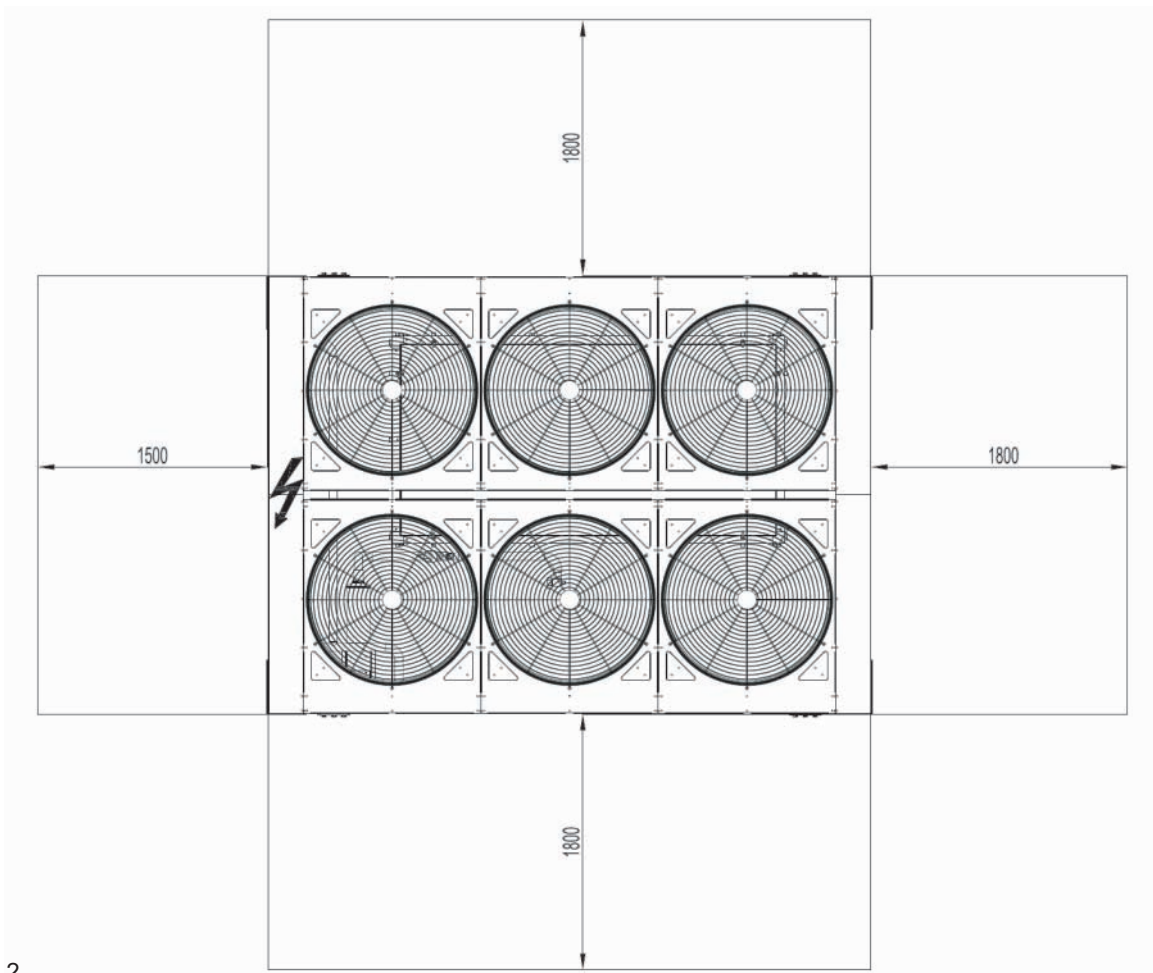

Fig. 2

11 Installation notes

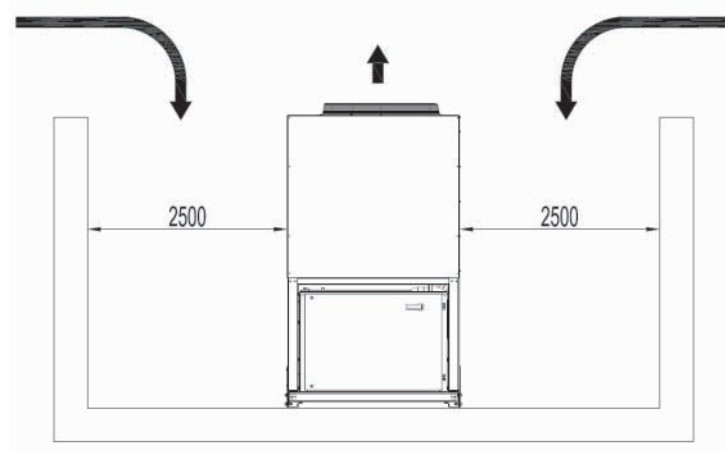

Fig. 3

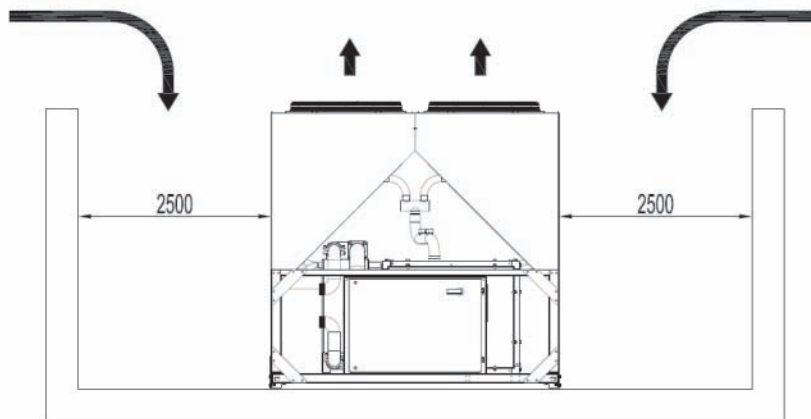

Fig. 4

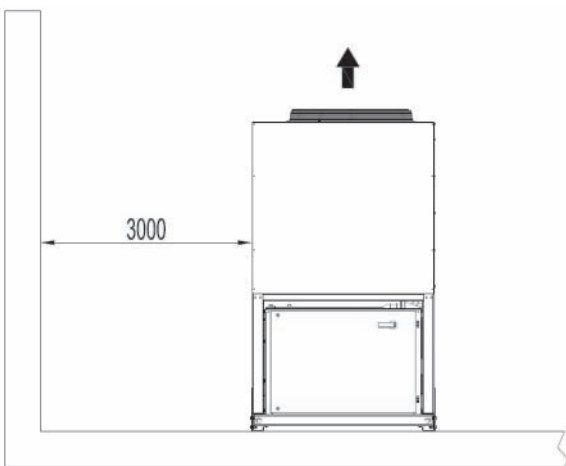

Fig. 5

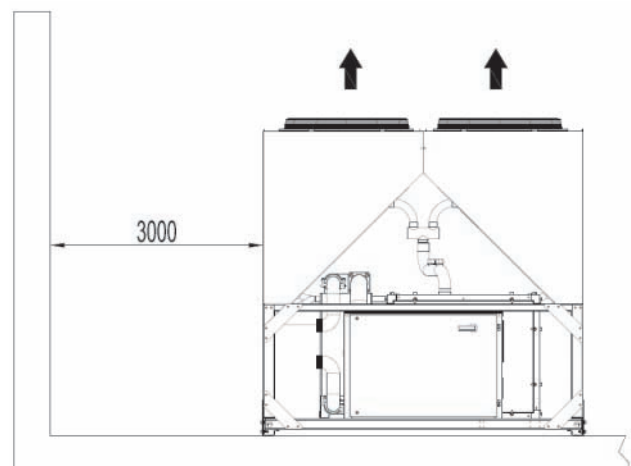

Fig. 6

11 Installation notes

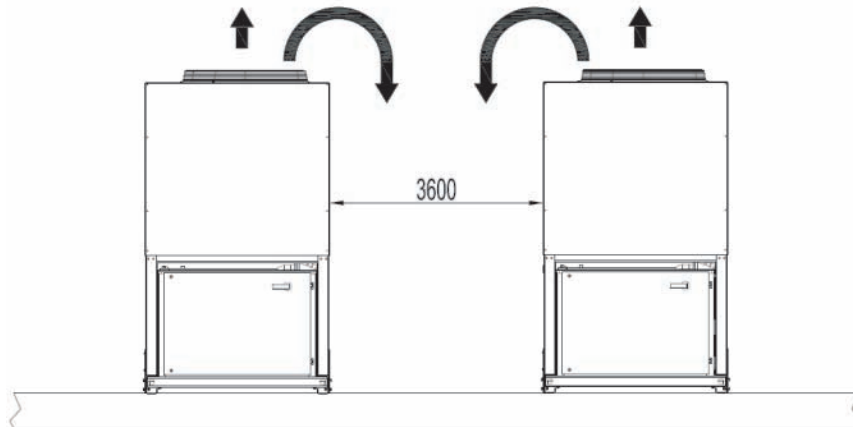

Fig. 7

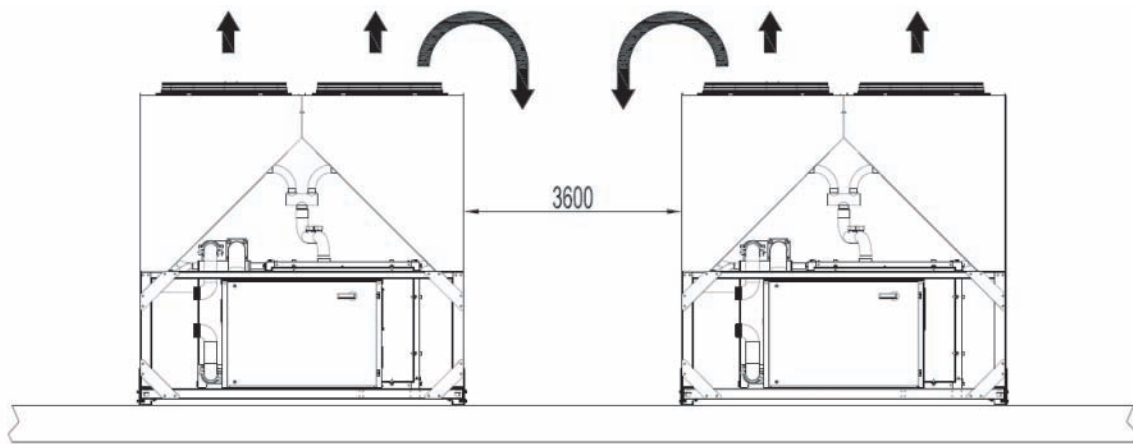

Fig. 8

Acoustic protection

When noise level must meet special requirements, it is necessary to pay the maximum attention to ensure the perfect insulation of the unit from the support base by applying appropriate vibration-dampening devices on the unit, on the water pipes and on the electrical connections.

Storage

The environment conditions have to be in the following limits:

- Minimum ambient temperature: -20°C
- Maximum ambient temperature: +57°C
- Maximum R.H.: 95% not condensing

12 Specification

Technical Specification for Air Cooled Screw Chiller

GENERAL

The air cooled screw chiller will be designed and manufactured in accordance with following European directives:

Rating of chillers	EN 12055
Construction of pressure vessel	97/23/EC (PED)
Machinery Directive	98/37/EC as modified
Low Voltage	2006/95/EC
Electromagnetic Compatibility	2004/108/EC
Electrical & Safety codes	EN 60204-1 / EN 60335-2-40
Manufacturing Quality Stds	UNI – EN ISO 9001:2000

The unit will be tested at full load in the factory at the nominal working conditions and water temperatures. Before shipment a full test will be held to avoid any losses.

Chiller will be delivered to the job site completely assembled and charged with right refrigerant and oil quantity.

Comply with the manufacturer instructions for rigging and handling equipment.

The unit will be able to start up and operate as standard at full load and outside air temperature from °C to °C with an evaporator leaving fluid temperature between °C and °C

REFRIGERANT

Only HFC 134a will be accepted.

PERFORMANCE

- ✓ Number of air cooled screw chiller:
- ✓ Cooling capacity for single air cooled screw chiller: kW
- ✓ Power input for single air cooled screw chiller in cooling mode: kW
- ✓ Plate to plate heat exchanger entering water temperature in cooling mode: °C
- ✓ Plate to plate heat exchanger leaving water temperature in cooling mode: °C
- ✓ Plate to plate heat exchanger water flow: l/s
- ✓ Nominal outside working ambient temperature in cooling mode: °C
- ✓ Operating voltage range should be 400V ±10%, 3ph, 50Hz, voltage unbalance maximum 3%, without neutral conductor and shall only have one power connection point.

UNIT DESCRIPTION

Chiller shall include as standard not less than: one refrigerant circuit, semi-hermetic type rotary single screw compressor, electronic expansion device (EEXV), refrigerant direct expansion plate to plate heat exchanger, air-cooled condenser section, R134a refrigerant, lubrication system, motor starting components, discharge line shut-off valve, suction line shut-off valve, control system and all components necessary for safe and stable unit operation.

Chiller will be factory assembled on a robust base-frame made of galvanized steel, protected by an epoxy paint.

NOISE LEVEL AND VIBRATIONS

Sound pressure level at 1 meter distance in free field, semispheric conditions, shall not exceeddB(A). The sound pressure levels must be rated in accordance to ISO 3744.

Other types of rating unacceptable. Vibration on the base frame should not exceed 2 mm/s.

12 Specification

DIMENSIONS

Unit dimensions shall not exceed following indications:

- ✓ unit length mm,
- ✓ unit width mm,
- ✓ unit height mm.

CHILLER COMPONENTS

Compressors

From size EWAD100E-SS to size EWAD 210E-SS and from size EWAD100E-SL to size EWAD210E-SL

- ✓ Semi-hermetic, single-screw type with one main helical rotor meshing with gaterotor. The gaterotor will be constructed of a carbon impregnated engineered composite material. The gaterotor supports will be constructed of cast iron.

From size EWAD260E-SS to size EWAD 410E-SS and from size EWAD250E-SL to size EWAD400E-SL

- ✓ Semi-hermetic, single-screw asymmetric type with one main helical rotor meshing with two diametrical opposed gaterotors. The gaterotors' contact elements shall be constructed of composite material designed for extended life. Electrical motor shall be 2-pole, semi-hermetic, squirrel-cage induction type and cooled by suction gas.
- ✓ The oil injection shall be used in order to get high EER (Energy Efficiency Ratio) also at high condensing pressure and low sound pressure levels in each load condition.
- ✓ The compressor shall be provided with a built in, high efficiency, mesh type oil separator and oil filter
- ✓ Refrigerant system differential pressure shall provide oil injection on all moving compressor parts to correctly lubricate them. Electrical oil pump lubricating system is not acceptable.
- ✓ Compressor cooling must be done by refrigerant liquid injection. External dedicated heat exchanger and additional piping to carry the oil from the compressor to heat exchanger and viceversa will be not accepted.
- ✓ The compressor shall be direct electrical driven, without gear transmission between the screw and the electrical motor.
- ✓ The compressor casing shall be provided with ports to realize economized refrigerant cycles.
- ✓ Compressor must be protected by temperature sensor for high discharge temperature and electrical motor thermistor for high winding temperature.
- ✓ The compressor shall be equipped with an electric oil heater.
- ✓ Compressor shall be fully field serviceable. Compressor that must be removed and returned to the factory for service shall be unacceptable.

Cooling capacity control system

- ✓ Each chiller will have a microprocessor for the control of compressor slide valve position.
- ✓ The unit capacity control shall be infinitely modulating, from 100% down to 25% for each circuit. The chiller shall be capable of stable operation to a minimum of 25% of full load without hot gas bypass.
- ✓ The system shall control the unit based on the leaving evaporator water temperature that shall be controlled by a PID (Proportional Integral Derivative) logic.
- ✓ Unit control logic shall manage the compressor slides to exactly match plant load request in order to keep constant the set point for delivered chilled water temperature.
- ✓ The microprocessor unit control shall detect conditions that approach protective limits and take self-corrective action prior to an alarm occurring. The system shall automatically reduce chiller capacity when any of the following parameters are outside their normal operating range:
 - o High condenser pressure
 - o Low evaporation refrigerant temperature

12 Specification

Evaporator

- ✓ The units shall be equipped with a Direct Expansion plate to plate evaporator with copper tubes rolled into steel tubesheets.
- ✓ The external shell shall be linked with an electrical heater to prevent freezing down to -28°C ambient temperature, controlled by a thermostat and shall be insulated with flexible, closed cell polyurethane insulation material (10 mm thick).
- ✓ The evaporator will have 1 circuit, and shall be single refrigerant pass.
- ✓ The water connections shall be threaded type connections as standard to ensure quick mechanical disconnection between the unit and the hydronic network.
- ✓ Evaporator is manufactured in accordance to PED approval.

Condenser coil

- ✓ The condenser coils are constructed with internally finned seamless copper tubes and arranged in a staggered row pattern and mechanically expanded into lanced and rippled aluminium fins with full fin collars for higher efficiencies. The space between the fins is given by a collar that will increase the surface area in connection with the tubes, protecting them from ambient corrosion.
- ✓ The coils will have an integral subcooler circuit that provides sufficient subcooling to effectively eliminate the possibility of liquid flashing and increase the unit's efficiency of 5-7% without increasing in energy consumption.
- ✓ The condenser coil shall be leak-tested and submitted to a pressure test with dry air.

Condenser fans

- ✓ The fans used in conjunction with the condenser coils, shall be propeller type with glass reinforced resin blades for higher efficiencies and lower noise. Each fan shall be protected by a fan guard.
- ✓ The air discharge shall be vertical and each fan must be coupled to the electrical motor, supplied as standard to IP54 and capable to work to ambient temperatures of - 20°C to + 65°C.
- ✓ They shall have as a standard a thermally protection by internal thermal motor protection and protected by circuit breaker installed inside the electrical panel as a standard.

Refrigerant circuit

- ✓ The circuit shall include as standard: electronic expansion device piloted by unit's microprocessor control, compressor discharge shut-off valve, suction shut-off valve, replaceable core filter-drier, sight glass with moisture indicator and insulated suction line.

Condensation control

- ✓ The units will be provided with an automatic control for condensing pressure which ensures the working at low external temperatures down to - °C, to maintain condensing pressure.
- ✓ Compressor automatically unloads when abnormal high condensing pressure is detected to prevent the shutdown of the refrigerant circuit (shutdown of the unit) due to a high-pressure fault.

Low Noise unit options (on request)

- ✓ The unit compressor shall be connected with unit's metal baseframe by rubber antivibration supports to prevent the transmission of vibrations to all metal unit structure and so to control the unit noise.
- ✓ The chiller shall be provided with an acoustically compressor enclosure. This enclosure shall be realized with a light, corrosion resisting aluminium structure and metal panels. The compressor sound-proof enclosure shall be internally fitted with flexible, multi layer, high density materials.

12 Specification

Hydronic kit options (on request)

- ✓ The hydronic module shall be integrated in the chiller chassis without increasing its dimensions and include the following elements: centrifugal water pump with three-phase motor equipped with internal over-temperature protection, safety relief valve, filling kit.
- ✓ The water piping shall be protected against corrosion and equipped with drain and purge plugs. The customer connections shall be Victaulic connections. The piping shall be fully insulated to prevent condensation (pump insulation using polyurethane foam).
- ✓ A choice of two pump types shall be available on unit with 2 compressors:
 - o in-line single pump low and high lifting
 - o in-line twin pumps low and high lifting

Control panel

- ✓ Field power connection, control interlock terminals, and unit control system should be centrally located in an electric panel (IP 54). Power and starting controls should be separate from safety and operating controls in different compartments of the same panel.
- ✓ Starting will be Wye-Delta type (Y-Δ).
- ✓ Operating and safety controls should include energy saving control; emergency stop switch; overload protection for compressor motor; high and low pressure cut-out switch (for each refrigerant circuit); anti-freeze thermostat; cut-out switch for each compressor.
- ✓ All of the information regarding the unit will be reported on a display and with the internal built-in calendar and clock that will switch the unit ON/OFF during day time all year long.
- ✓ The following features and functions shall be included:
 - leaving water temperature reset by controlling the water temperature Δt , by a remote 4-20mA DC signal or by controlling the external ambient temperature;
 - soft load function to prevent the system from operating at full load during the chilled fluid pulldown period;
 - password protection of critical parameters of control;
 - start-to-start and stop-to-start timers to provide minimum compressor off-time with maximum motor protection;
 - communication capability with a PC or remote monitoring;
 - discharge pressure control through intelligent cycling of condenser fans;
 - lead-lag selection by manual or automatically by circuit run hours;
 - double set point for brine unit version;
 - scheduling via internal time clock to allow programming of a yearly start-stop schedule accommodating weekends and holidays.

Optional High Level Communications Interface

Chiller must be able to communicate to BMS (Building Management System) based on the most common protocols as:

- ModbusRTU
- LonWorks, now also based on the international 8040 Standard Chiller Profile and LonMark Technology
- BacNet BTP certified over IP and MS/TP (class 4) (Native)
- Ethernet TCP/IP.