

Service Manual

Multi-Split Air Conditioner



CS-C9BKPG CU-2C14BKP5G
 CS-C9BKPG CU-2C18BKP5G
 CS-C9BKPG CU-3C20BKP5G
 CS-C7BKPG CU-2C19BKP5G
 CS-C12BKPG



⚠ WARNING

This service information is designed for experienced repair technicians only and is not designed for use by the general public. It does not contain warnings or cautions to advise non-technical individuals of potential dangers in attempting to service a product. Products powered by electricity should be serviced or repaired only by experienced professional technicians. Any attempt to service or repair the product or products dealt with in this service information by anyone else could result in serious injury or death.

⚠ PRECAUTION OF LOW TEMPERATURE

In order to avoid frostbite, be assured of no refrigerant leakage during the installation or repairing of refrigeration circuit.

CONTENTS

	Page		Page
1 Features	2	11 3-way Valve	49
2 Functions	3	12 Servicing Information	56
3 Product Specifications	6	13 Troubleshooting Guide	60
4 Dimensions	14	14 Technical Data	62
5 Refrigeration Cycle Diagram	16	15 Exploded View	69
6 Block Diagram	18	16 Replacement Parts List	70
7 Wiring Diagram	22	17 Exploded View	71
8 Operation Details	26	18 Replacement Parts List	72
9 Operating Instructions	34	19 Exploded View	73
10 Installation Instructions	39	20 Replacement Parts List	74

Panasonic

© 2002 Matsushita Air-Conditioning Corp. Sdn. Bhd. (183914D). All rights reserved. Unauthorized copying and distribution is a violation of law.

21 Exploded View	75	24 Replacement Parts List	78
22 Replacement Parts List	76	25 Electronic Parts List	79
23 Exploded View	77	26 Electronic Circuit Diagram	80

1 Features

- **High Efficiency**
- **Compact Design**
- **Comfort Environment**
 - 8 hours of sleep mode operation
 - Air filter with function to reduce dust and smoke
 - Wider range of horizontal discharge air
- **Auto Restart**
 - Random auto restart after power failure for safety restart operation
- **Removable and Washable Front Panel**
- **Remote Control Self-illuminating Button**
- **Catechin Air Purifying Filter**
 - Trap dust, tobacco smoke and tiny particles
 - Prevent the growth of bacteria and viruses trapped
- **Solar Refreshing Deodorizing Filter**
 - Remove unpleasant odour from the air
- **Quality Improvement**
 - Gas leakage protection
 - Prevent compressor reverse cycle
 - 2-stage OLP to protect compressor
 - Noise prevention during soft dry operation.
 - Anti-dew Formation Control (Cooling & Soft Dry)
- **Operation Improvement**
 - Economy mode to reduce electrical power consumption
 - Powerful mode to reach the desired room temperature quickly
- **Long Installation Piping**
 - Long piping up to 15 meter
- **24-hour Timer Setting**

2 Functions

Remote Control

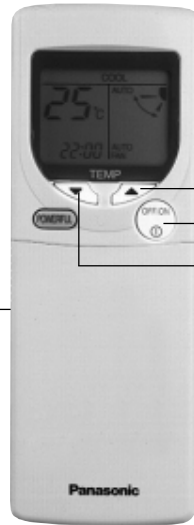

Self illuminating button

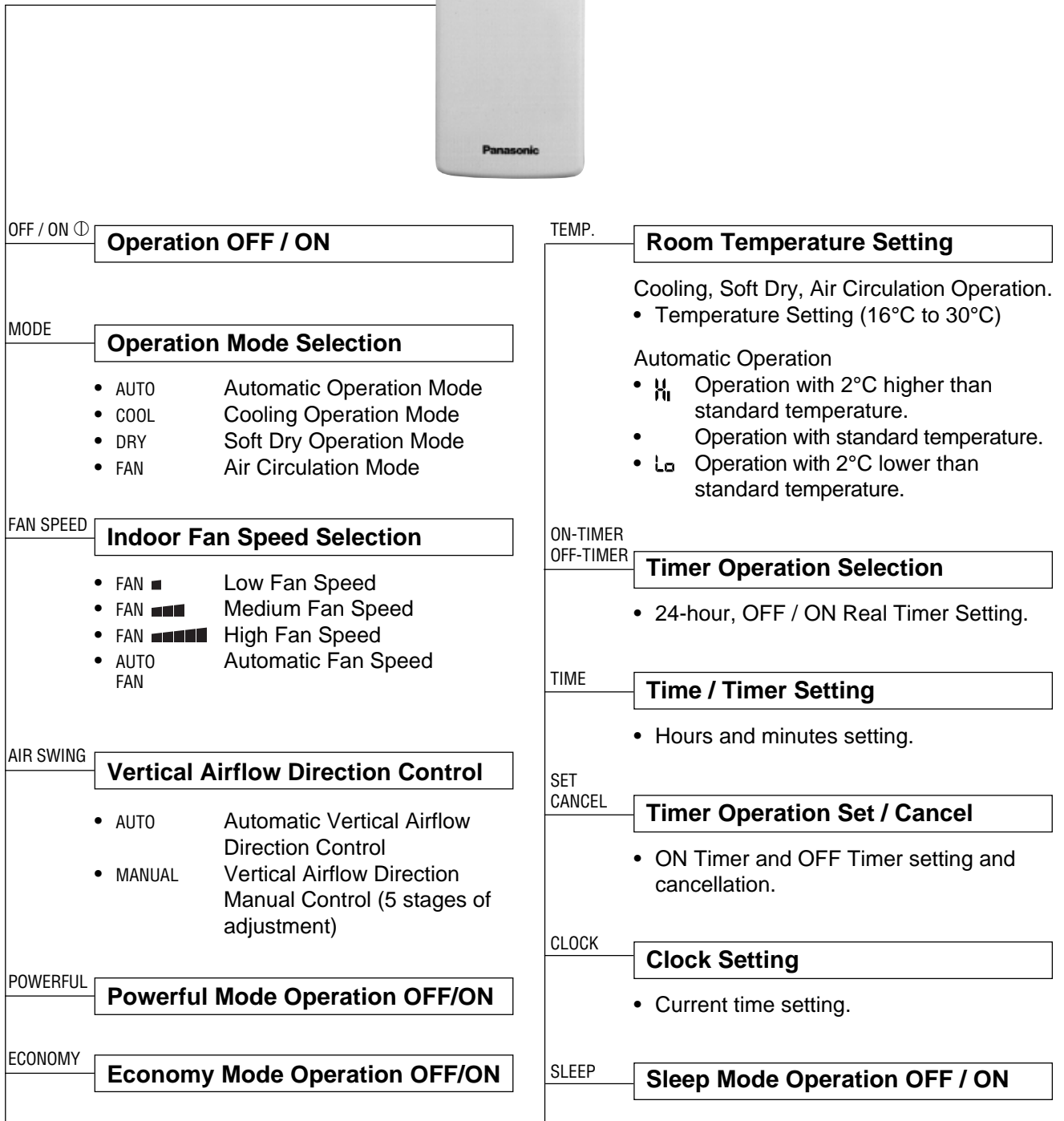

Indoor Unit



AUTO
OFF / ON

Automatic Operation Button

- Press for < 5s to operate Automatic operation mode.
(Used when the remote control cannot be used.)
- Press continuously for 5s or < 10s to operate Test Run/Pump down. “Beep” sound will be heard at the 5th second.
(Used when test running or servicing.)
- Press continuously for 10s and above to omit or resume the remote control signal receiving sound. “Beep, beep” sound will be heard at the 10th second.

Operation Indication Lamps (LED)

- POWER (Green) Lights up in operation, blinks in Automatic Operation Mode judging.
- SLEEP (Orange) Lights up in Sleep Mode Operation.
- TIMER (Orange) Lights up in Timer Setting.
- POWERFUL (Orange) .. Lights up in Powerful Mode Operation.
- ECONOMY (Green) Lights up in Economy Mode Operation.

Operation Mode

- Cooling, Soft Dry, Air Circulation and Automatic Mode.

Powerful Operation

- Reaches the desired room temperature quickly.

Economy Operation

- To reduce electrical power consumption.

Random Auto Restart Control

- Operation is restarted randomly after power failure at previous setting mode.

Anti-Freezing Control

- Anti-Freezing control for indoor heat exchanger. (Cooling and Soft Dry)

Sleep Mode Auto Control

- Indoor Fan operates at Low speed.
- Operation stops after 8 hours.

Indoor Fan Speed Control

- High, Medium and Low.
- Automatic Fan Speed Mode
 - Cooling : Fan rotates at Hi, Me and SLo speed. Deodorizing control is available.
 - Soft Dry: Fan rotates at SLo speed. Deodorizing control is available.

Airflow Direction Control

- Automatic air swing and manual adjusted by remote control for vertical airflow.
- Manually adjusted by hand for horizontal airflow.

Starting Current Control

- Fan motor is delayed for 1.6 seconds when compressor starts simultaneously.

Time Delay Safety Control

- Restarting is inhibited for approx. 3 minutes.

7 Minutes Time Save Control

- Cooling Operation only.

Anti-Dew Formation Control

- Anti-Dew Formation Control for indoor unit discharge area.

Outdoor Unit

CU-2C14BK, CU-2C18BK, CU-2C19BK & CU-3C20BK



Compressor Reverse Rotation Protection Control

- To protect compressor from reverse rotation when there is a instantaneous power failure.



Overload Protector

- 2-Stage OLP to protect the compressor. Overload Protector will trip when
 - Temperature of compressor increases to 120°C.
 - High temperature or high current flows to compressor. (Refer circuit diagram for OLP characteristic)





60 Secs. Forced Operation Control

- Once the compressor is activated, it does not stop within the first 60 secs. However, it stops immediately with remote control stop signal.

Outdoor Fan Operation Control

- Temperature Fuse.

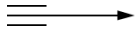
3 Product Specifications

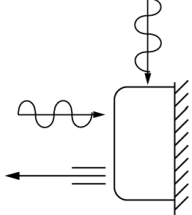
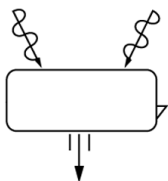
		Unit	CS-C9BKPG	CU-2C14BKPG5G
Power Source		Phase V Cycle	Europe: 230 - 220	Single Oceania: 240 - 220 50
Cooling Capacity		kW kcal/h	(1 unit) 2.82 - 2.78 2,430 - 2,390	(2 units) 3.62 - 3.58 3,110 - 3,080
Moisture Removal		l/h Pint/h	(1 unit) 1.6 3.4	(2 units) 2.1 4.4
Airflow Method		<p>OUTLET</p>  <p>INTAKE</p> 	<p>SIDE VIEW</p> 	<p>TOP VIEW</p> 
Air Volume	Indoor Air (Lo)	m ³ /min (cfm)	6.8 (240) - 6.8 (240)	—
	Indoor Air (Me)	m ³ /min (cfm)	8.0 (280) - 8.0 (280)	—
	Indoor Air (Hi)	m ³ /min (cfm)	9.9 (350) - 9.9 (350)	—
	Indoor Air (SHi)	m ³ /min (cfm)	10.9 (380) - 10.9 (380)	—
Noise Level		dB (A)	High 36 - 36, Low 26 - 26	High 47 - 46
		Power level dB	High 49 - 49	High 62 - 61
Electrical Data	Input	W	(1 unit) 1,150 - 1,100	(2 units) 1,220 - 1,160
	Running Current	A	(1 unit) 5.1 - 5.2	(2 units) 5.4 - 5.5
	EER	W/W kcal/hW	(1 unit) 2.45 - 2.53 2.11 - 2.17	(2 units) 2.97 - 3.09 2.55 - 2.66
	Starting Current	A	20.5 - 19.5	
Piping Connection Port (Flare piping)		inch inch	G ; Half Union 3/8" L ; Half Union 1/4"	G ; 3-way valve 3/8" L ; 3-way valve 1/4"
Pipe Size (Flare piping)		inch inch	G (gas side) ; 3/8" L (liquid side) ; 1/4"	G (gas side) ; 3/8" L (liquid side) ; 1/4"
Drain Hose	Inner diameter	mm	12	—
	Length	m	0.7	—
Dimensions	Height	inch (mm)	10 - 13/16 (275)	21 - 1/4 (540)
	Width	inch (mm)	31 - 15/32 (799)	29 - 15/16 (760)
	Depth	inch (mm)	8 - 9/32 (210)	9 - 7/8 (250)
Net Weight		lb (kg)	20 (9.0)	77 (35.0)
Compressor	Type		—	Rotary (1 cylinder) rolling piston type
	Motor Type		—	Induction (2-poles)
	Rated Output	W	—	900

Air Circulation	Type		Cross-flow Fan	Propeller Fan	
	Material		AS + Glass Fiber 20%	AS + Glass Fiber 20%	
	Motor	Type	Induction (4-poles)	Induction (6-poles)	
		Input	W	29.3 - 26.3	41.75 - 36.80
	Rated Output		W	15	12
	Fan Speed	Low	rpm	780 - 780	—
		Medium	rpm	920 - 920	—
		High	rpm	1,140 - 1,140	795 - 750
SuperHigh		rpm	1,250 - 1,250	—	
Heat Exchanger	Description		Evaporator	Condenser	
	Tube material		Copper	Copper	
	Fin material		Aluminium	Aluminium	
	Fin Type		Slit Fin	Louver Fin	
	Row / Stage		(Plate fin configuration, forced draft)		
			2 x 15	1 x 20	
	FPI		19	19	
Size (W x H x L)		mm	610 x 315 x 25.4	687 x 508 x 22	
Refrigerant Control Device			—	Capillary Tube	
Refrigeration Oil		(c.c)	—	SUNISO 4GDID or ATMOS M60 (350)	
Refrigerant (R-22)		g (oz)	—	890 (31.4)	
Thermostat			Electronic Control	—	
Protection Device			—	Overload Protector	
Capillary Tube	Length	mm	—	505	
	Flow Rate	l/min	—	17.8	
	Inner Diameter	mm	—	1.7	
Air Filter	Material	(c.c)	P.P.	—	
	Style		Honeycomb		
Capacity Control			Capillary Tube		
Compressor Capacitor		µF, VAC	—	30 µF, 440 VAC	
Fan Motor Capacitor		µF, VAC	1.5 µF, 400 VAC	1.0 µF, 430 VAC	

- Specifications are subject to change without notice for further improvement.

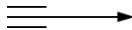
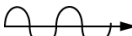
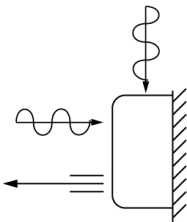
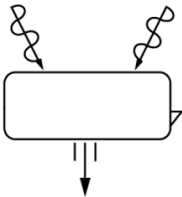
		Unit	CS-C9BPKG	CU-2C18BKP5G
Power Source		Phase V Cycle	Europe: 230 - 220	Single Oceania: 240 - 220 50
Cooling Capacity		kW kcal/h	(1 unit) 2.44 - 2.40 2,100 - 2,060	(2 units) 4.88 - 4.80 4,200 - 4,130
Moisture Removal		l/h Pint/h	(1 unit) 1.5 3.2	(2 units) 2.6 5.5
Airflow Method		<p>OUTLET</p>  <p>INTAKE</p> 	<p>SIDE VIEW</p> 	<p>TOP VIEW</p> 
Air Volume	Indoor Air (Lo)	m ³ /min (cfm)	6.8 (240) - 6.8 (240)	—
	Indoor Air (Me)	m ³ /min (cfm)	8.0 (280) - 8.0 (280)	—
	Indoor Air (Hi)	m ³ /min (cfm)	9.9 (350) - 9.9 (350)	—
	Indoor Air (SHi)	m ³ /min (cfm)	10.9 (380) - 10.9 (380)	—
Noise Level		dB (A)	High 36 - 36, Low 26 - 26	High 55 - 53
		Power level dB	High 49 - 49	High 70 - 68
Electrical Data	Input	W	(1 unit) 770 - 730	(2 units) 1,540 - 1,460
	Running Current	A	(1 unit) Europe: 3.4 - 3.5 Oceania: 3.3 - 3.5	(2 units) Europe: 6.8 - 7.0 Oceania: 6.6 - 7.0
	EER	W/W (kcal/hW)	3.17 - 3.29 (2.73 - 2.83)	
	Starting Current	A	15.5 - 15.0	
Piping Connection Port (Flare piping)		inch inch	G ; Half Union 3/8" L ; Half Union 1/4"	G ; 3-way valve 3/8" L ; 3-way valve 1/4"
Pipe Size (Flare piping)		inch inch	G (gas side) ; 3/8" L (liquid side) ; 1/4"	G (gas side) ; 3/8" L (liquid side) ; 1/4"
Drain Hose	Inner diameter	mm	12	—
	Length	m	0.7	—
Dimensions	Height	inch (mm)	10 - 13/16 (275)	25 - 21/32 (651)
	Width	inch (mm)	31 - 15/32 (799)	35 - 3/16 (893)
	Depth	inch (mm)	8 - 9/32 (210)	13 - 19/32 (345)
Net Weight		lb (kg)	20 (9.0)	137 (62)
Compressor	Type		—	Rotary (1 cylinder) rolling piston type
	Motor Type		—	Induction (2-poles)
	Rated Output	W	—	650

Air Circulation	Type		Cross-flow Fan	Propeller Fan	
	Material		AS + Glass Fiber 20%	AS + Glass Fiber 20%	
	Motor Type		Induction (4-poles)	Induction (6-poles)	
	Input	W	29.3 - 26.3	117.1 - 103.3	
	Rated Output	W	15	43	
	Fan Speed	Low	rpm	780 - 780	—
		Medium	rpm	920 - 920	—
		High	rpm	1,140 - 1,140	760 - 720
SuperHigh		rpm	1,250 - 1,250	—	
Heat Exchanger	Description		Evaporator	Condenser	
	Tube material		Copper	Copper	
	Fin material		Aluminium	Aluminium	
	Fin Type		Slit Fin	Louver Fin	
	Row / Stage		(Plate fin configuration, forced draft)		
			2 x 15	2 x 24	
	FPI		19	16	
Size (W x H x L)	mm	610 x 315 x 25.4	560 x 609.6 x 44		
Refrigerant Control Device			—	Capillary Tube	
Refrigeration Oil	(c.c)		—	SUNISO 4GDID or ATMOS M60 (270)	
Refrigerant (R-22)	g (oz)		—	750 x 2 (26.5 x 2)	
Thermostat			Electronic Control	—	
Protection Device			—	Overload Protector	
Capillary Tube	Length	mm	—	680	
	Flow Rate	l/min	—	11.5	
	Inner Diameter	mm	—	1.5	
Air Filter	Material	(c.c)	P.P.	—	
	Style		Honeycomb		
Capacity Control			Capillary Tube		
Compressor Capacitor		µF, VAC	—	25 µF, 370 VAC	
Fan Motor Capacitor		µF, VAC	1.5 µF, 400 VAC	3.0 µF, 450 VAC	

- Specifications are subject to change without notice for further improvement.

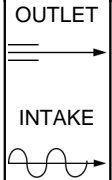
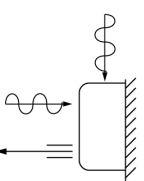
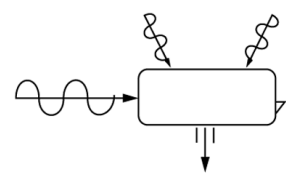
		Unit	CS-C9BPKG	CU-3C20BKP5G				
			Single Operation (A, B1, B2)	Single Operation		Double Operation		Triple Operation
				(A)	(B1 or B2)	(B1 + B2)	(A + B1 or B2)	(A + B1 + B2)
Power Source		Phase V Cycle	Single Europe: 230 - 220 Oceania: 240 - 220 50					
Cooling Capacity Per Unit		kW kcal/h	— —	2.40-2.34 2,060-2,010	2.82-2.78 2,430-2,390	3.60-3.52 3,100-3,030	5.22-5.12 4,490-4,400	6.00-5.86 5,160-5,040
Moisture Removal		l/h Pint/h	— —	1.5 3.2	1.6 3.4	2.1 4.4	2.8 5.9	3.2 6.8
Airflow Method		OUTLET  INTAKE	SIDE VIEW 	TOP VIEW 				
Air Volume	Indoor Air (Lo)	m ³ /min (cfm)	6.8 - 6.8 (240 - 240)	—				
	Indoor Air (Me)	m ³ /min (cfm)	8.0 - 8.0 (280 - 280)	—				
	Indoor Air (Hi)	m ³ /min (cfm)	9.9 - 9.9 (350 - 350)	—				
	Indoor Air (SHi)	m ³ /min (cfm)	10.9 - 10.9 (380 - 380)	—				
Noise Level		dB (A)	High 36 - 36, Low 26 - 26	High 56 - 54				
		Power level dB	High 49 - 49	High 71 - 69				
Electrical Data	Input	W	50 - 50	820-770	1,120-1,070	1,210-1,150	1,850-1,750	1,920-1,840
	Running Current	A	0.23 - 0.23	3.6 - 3.7	Europe: 5.0 - 5.1 Oceania: 4.9 - 5.1	Europe: 5.4 - 5.5 Oceania: 5.3 - 5.5	8.1 - 8.3	Europe: 8.4 - 8.7 Oceania: 8.3 - 8.7
	EER	W/W (kcal/hW)	—	2.93 - 3.04 (2.51 - 2.61)	2.52 - 2.60 (2.17 - 2.23)	2.98 - 3.06 (2.56 - 2.63)	2.82 - 2.93 (2.43 - 2.51)	3.13 - 3.18 (2.69 - 2.74)
	Starting Current	A	(A unit) 15.5 - 15.0		(B unit) 21.5 - 21.0			
Piping Connection Port (Flare piping)		inch inch	G ; Half Union 3/8" L ; Half Union 1/4"	G ; 3-way valve 3/8" L ; 3-way valve 1/4"				
Pipe Size (Flare piping)		inch inch	G (gas side) ; 3/8" L (liquid side) ; 1/4"	G (gas side) ; 3/8" L (liquid side) ; 1/4"				
Drain Hose	Inner diameter	mm	12	—				
	Length	m	0.7	—				
Dimensions	Height	inch (mm)	10 - 13/16 (275)	25 - 21/32 (651)				
	Width	inch (mm)	31 - 15/32 (799)	35 - 3/16 (893)				
	Depth	inch (mm)	8 - 9/32 (210)	13 - 19/32 (345)				
Net Weight		lb (kg)	20 (9.0)	146 (66)				
Compressor	Type		—	Rotary (1 cylinder) rolling piston type				
	Motor Type		—	Induction (2-poles)				
	Rated Output	W	—	(A unit) 650		(B unit) 900		

Air Circulation	Type		Cross-flow Fan	Propeller Fan	
	Material		AS + Glass Fiber 20%	AS + Glass Fiber 20%	
	Motor Type		Induction (4-poles)	Induction (6-poles)	
	Input	W	29.3 - 26.3	121.82 - 107.91	
	Rated Output	W	15	37	
	Fan Speed	Low	rpm	780 - 780	—
		Medium	rpm	920 - 920	—
High		rpm	1,140 - 1,140	765 - 725	
SuperHigh		rpm	1,250 - 1,250	—	
Heat Exchanger	Description		Evaporator	Condenser	
	Tube material		Copper	Copper	
	Fin material		Aluminium	Aluminium	
	Fin Type		Slit Fin	Louver Fin	
	Row / Stage		2 x 15	(Plate fin configuration, forced draft) 2 x 24	
	FPI		19	16	
	Size (W x H x L)	mm	610 x 315 x 25.4	756.0 x 609.6 x 44 719.5	
Refrigerant Control Device		—	Capillary Tube		
Refrigeration Oil	(c.c)	—	SUNISO 4GDID or ATMOS M60 (320, 270)		
Refrigerant (R-22)	g (oz)	—	(A unit) 800 (28.2) (B unit) 1,070 (37.7)		
Thermostat		Electronic Control	—		
Protection Device		—	Overload Protector		
Capillary Tube	Length	mm	—	935, 920, 1,170	
	Flow Rate	l/min	—	20.0, 15.5, 10.0	
	Inner Diameter	mm	—	2.0, 1.8, 1.6	
Air Filter	Material Style		P.P. Honeycomb	—	
Capacity Control				Capillary Tube	
Compressor Capacitor	μF, VAC		—	25 μF, 440 VAC	
Fan Motor Capacitor	μF, VAC		1.5 μF, 400 VAC	3.0 μF, 450 VAC	

- Specifications are subject to change without notice for further improvement.

		Unit	One Unit (A) CS-C12BKP5G	One Unit (B) CS-C7BKP5G	CU-2C19BKP5G	
Cooling Capacity		kW kcal/h	(A) 3.55 - 3.52 (A) 3,050 - 3,030	(B) 2.08 - 2.06 (B) 1,790 - 1,770	(A+B) 5.63 - 5.58 (A+B) 4,840 - 4,800	
Moisture Removal		l/h Pint/h	(A) 2.1 4.4	(B) 1.4 3.0	(A+B) 3.1 6.6	
Power Source		Phase V Cycle	Single 230 - 220 50			
Airflow Method		<p>OUTLET</p> <p>INTAKE</p>	<p>SIDE VIEW</p>		<p>TOP VIEW</p>	
Air Volume	Indoor Air (Lo)	m ³ /min (cfm)	7.3 - 7.3 (260 - 260)	6.4 - 6.4 (230 - 230)	—	
	Indoor Air (Me)	m ³ /min (cfm)	8.7 - 8.7 (310 - 310)	7.4 - 7.4 (260 - 260)	—	
	Indoor Air (Hi)	m ³ /min (cfm)	10.2 - 10.2 (360 - 360)	8.5 - 8.5 (300 - 300)	—	
	Indoor Air (SHi)	m ³ /min (cfm)	10.5 - 10.5 (370 - 370)	9.4 - 9.4 (330 - 330)	—	
Noise Level		dB (A)	(A) High 39 - 39 Low 29 - 29	(B) High 33 - 33 Low 26 - 26	High 55 - 53	
		Power level dB	(A) High 52 - 52	(B) High 46 - 46	High 70 - 68	
Electrical Data	Input	W	(A) 1,250 - 1,230	(B) 750 - 720	(A+B) 1,880 - 1,840	
	Running Current	A	(A) 5.7 - 5.9	(B) 3.9 - 3.8	(A+B) 9.0 - 9.1	
	EER	W/W (kcal/hW)	(A) 2.84 - 2.86 (2.44 - 2.46)	(B) 2.77 - 2.86 (2.39 - 2.46)	(A+B) 2.99 - 3.03 (2.57 - 2.61)	
	Starting Current	A	(A) 25 - 24	(B) 15 - 14	(A+B) 40 - 38	
Piping Connection Port (Flare piping)		inch inch	G ; Half Union 1/2", 3/8" L ; Half Union 1/4", 1/4"		G ; 3-way valve 1/2", 3/8" L ; 3-way valve 1/4", 1/4"	
Pipe Size (Flare piping)		inch inch	G (gas side) ; 1/2", 3/8" L (liquid side) ; 1/4", 1/4"		G (gas side) ; 1/2", 3/8" L (liquid side) ; 1/4", 1/4"	
Drain Hose	Inner diameter	mm	12		—	
	Length	m	0.7		—	
Dimensions	Height	inch (mm)	10 - 13/16 (275)		25 - 21/32 (651)	
	Width	inch (mm)	31 - 15/32 (799)		35 - 3/16 (893)	
	Depth	inch (mm)	8 - 9/32 (210)		13 - 19/32 (345)	
Net Weight		lb (kg)	20 (9.0)		148 (67)	
Compressor	Type		—		Rotary (1 cylinder) rolling piston type	
	Motor Type		—		Induction (2-poles)	
	Rated Output	W	(A) 1,100	(B) 600	(A+B) 1,700	
Air Circulation	Type		Cross-flow Fan		Propeller Fan	
	Material		AS + Glass Fiber 20%		AS + Glass Fiber 20%	
	Motor Type		Induction (4-poles)		Induction (6-poles)	
	Input	W	(A) 28.7 - 27.1	(B) 20.6 - 19.1	121.82 - 107.91	
	Rated Output	W	(A) 15	(B) 10	37	
	Fan Speed	Low	rpm	(A) 900 - 900	(B) 780 - 780	—
		Medium	rpm	(A) 1,080 - 1,080	(B) 900 - 900	—
		High	rpm	(A) 1,260 - 1,260	(B) 1,030 - 1,030	740 - 725
SuperHigh		rpm	(A) 1,300 - 1,300	(B) 1,140 - 1,140	—	

Heat Exchanger	Description		Evaporator	Condenser	
	Tube material		Copper	Copper	
	Fin material		Aluminium	Aluminium	
	Fin Type		Slit Fin	Louver Fin	
	Row / Stage		(Plate fin configuration, forced draft)		
	FPI		(A) 2 x 15 21	(B) 2 x 15 19	2 x 24 16
	Size (W x H x L)	mm	610 x 315 x 25.4		756 x 609.6 x 44 719.5
Refrigerant Control Device			—	Capillary Tube	
Refrigeration Oil	(c.c)		—	SUNISO 4GDID or ATMOS M60 (290, 410)	
Refrigerant (R-22)	g (oz)		—	(A) 840 (29.7) (B) 820 (28.9)	
Thermostat			Electronic Control	—	
Protection Device			—	Overload Protector	
Capillary Tube	Length	mm	—	(A) 610 (B) 920	
	Flow Rate	l/min	—	(A) 16.5 (B) 9.5	
	Inner Diameter	mm	—	(A) 1.7 (B) 1.5	
Air Filter	Material	(c.c)	P.P.	—	
	Style		Honeycomb		
Capacity Control			Capillary Tube		
Compressor Capacitor		µF, VAC	—	(A) 30 µF, 370 VAC (B) 15 µF, 440 VAC	
Fan Motor Capacitor		µF, VAC	1.5 µF, 400 VAC	3.0 µF, 450 VAC	

- Specifications are subject to change without notice for further improvement.

4 Dimensions

CS-C7BK / CS-C9BK / CS-C12BK

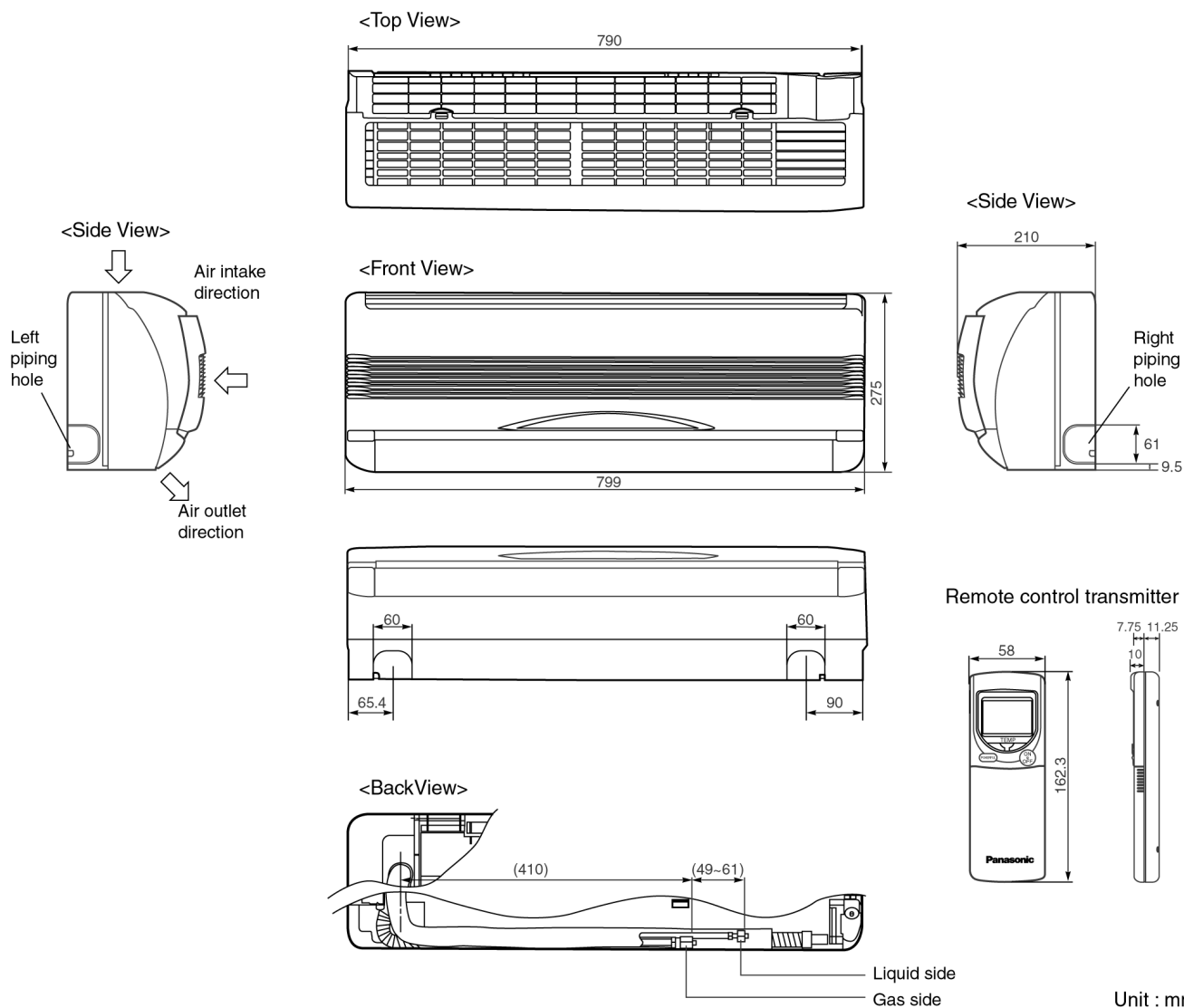

Relative position between the indoor unit and the installation plate <Front View>

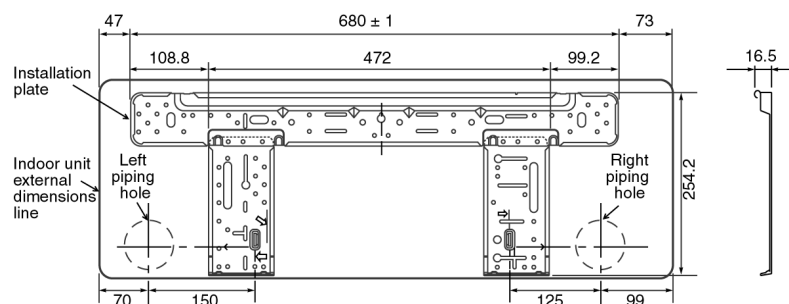

CU-2C14BK

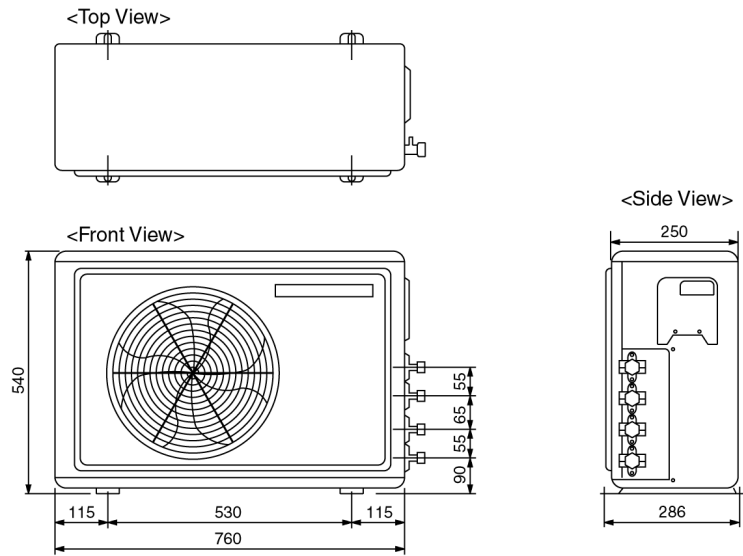

CU-2C18BK & CU-2C19BK

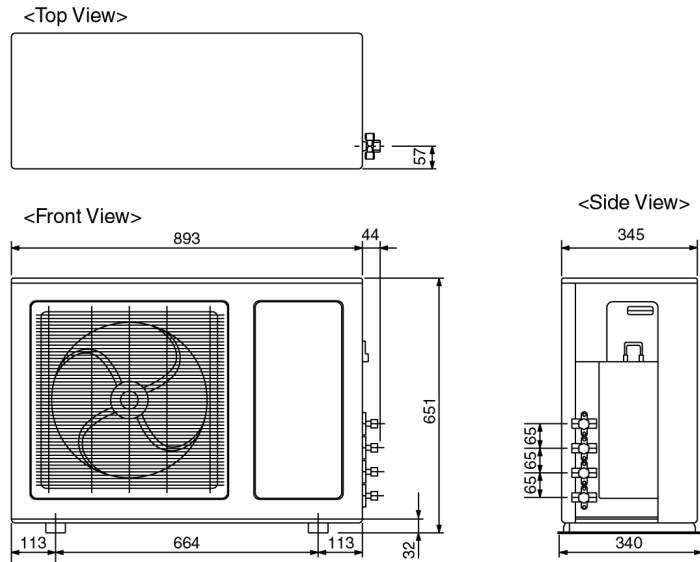

CU-3C20BK

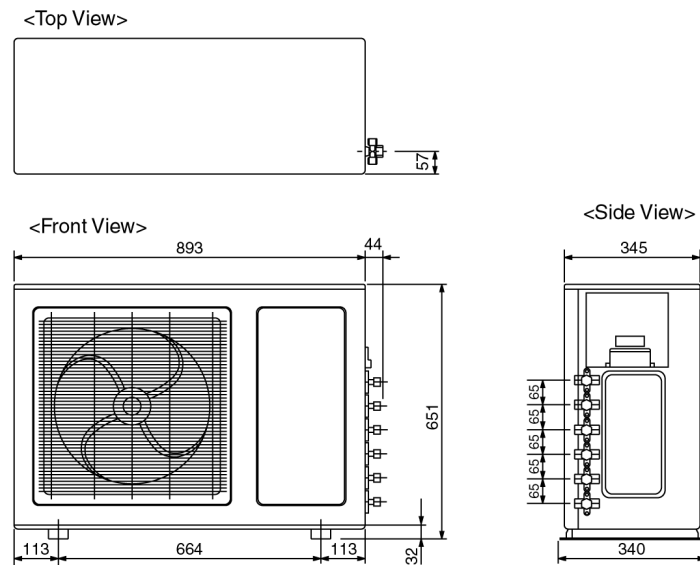

5 Refrigeration Cycle Diagram

CS-C9BK / CU-2C14BK

- ① Evaporator
- ② Capillary tube (2)
- ③ 3 way valve (1/4")
- ④ 3 way valve (3/8")
- ⑤ Half union (1/4")
- ⑥ Half union (3/8")
- ⑦ Switching solenoid valve (A)
- ⑧ Switching solenoid valve (B)
- ⑨ Capillary tube (1)
- ⑩ Condensator
- ⑪ Compressor
- ⑫ Outdoor unit
- ⑬ Strainer
- ⑭ To indoor unit B

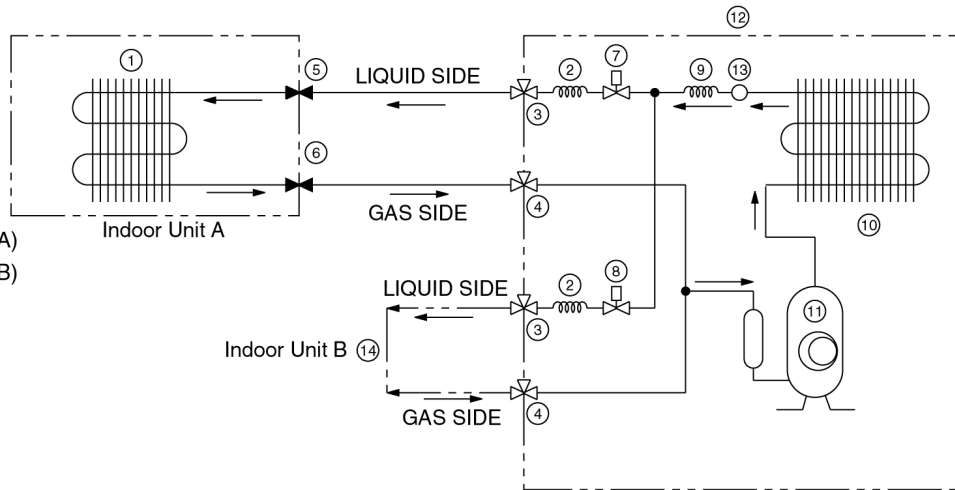

CS-C9BK / CU-2C18BK

- ① Evaporator
- ② Capillary tube (2)
- ③ 3 way valve (1/4")
- ④ 3 way valve (3/8")
- ⑤ Half union (1/4")
- ⑥ Half union (3/8")
- ⑩ Condensator
- ⑪ Compressor
- ⑫ Outdoor unit
- ⑬ Strainer

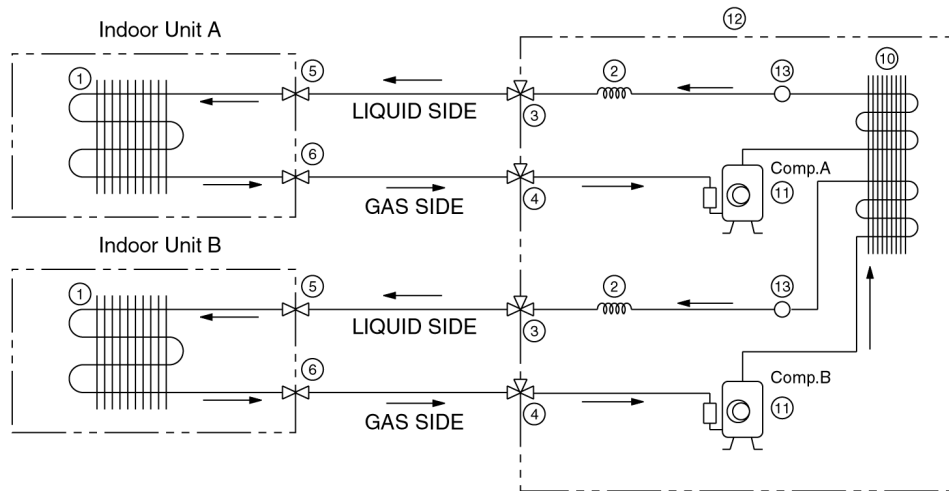

CS-C9BK / CU-3C20BK

- ① Compressor (1)
- ② Compressor (2)
- ③ Condensator
- ④ Capillary tube (1)
- ⑤ Capillary tube (2)
- ⑥ Capillary tube (3)
- ⑦ Switching solenoid valve
- ⑧ 3 way valve (1/4")
- ⑨ 3 way valve (3/8")
- ⑩ Half union (1/4")
- ⑪ Half union (3/8")
- ⑫ Evaporator

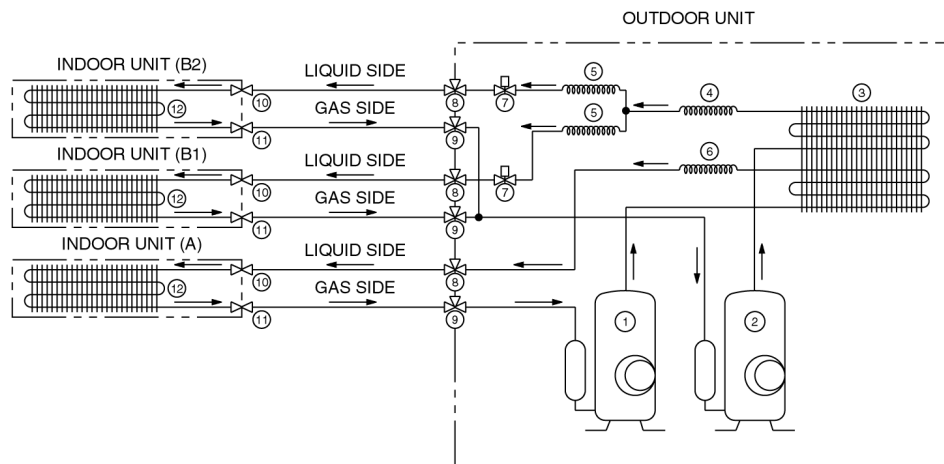

CS-C7BK, CS-C12BK / CU-2C19BK

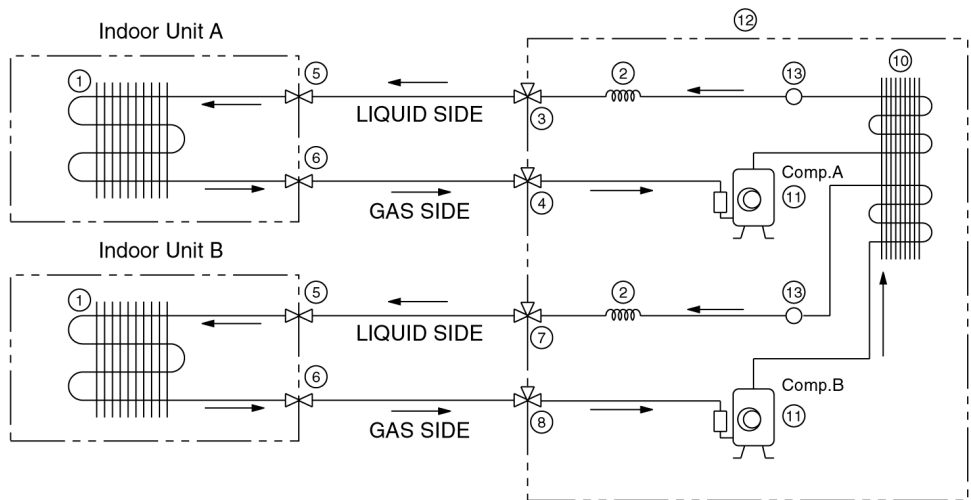

- ① Evaporator
- ② Capillary tube (2)
- ③ 3 way valve (1/4")
- ④ 3 way valve (1/2")
- ⑤ Half union
- ⑥ Half union
- ⑦ 3 way valve (1/4")
- ⑧ 3 way valve (3/8")
- ⑩ Condensor
- ⑪ Compressor
- ⑫ Outdoor unit
- ⑬ Strainer

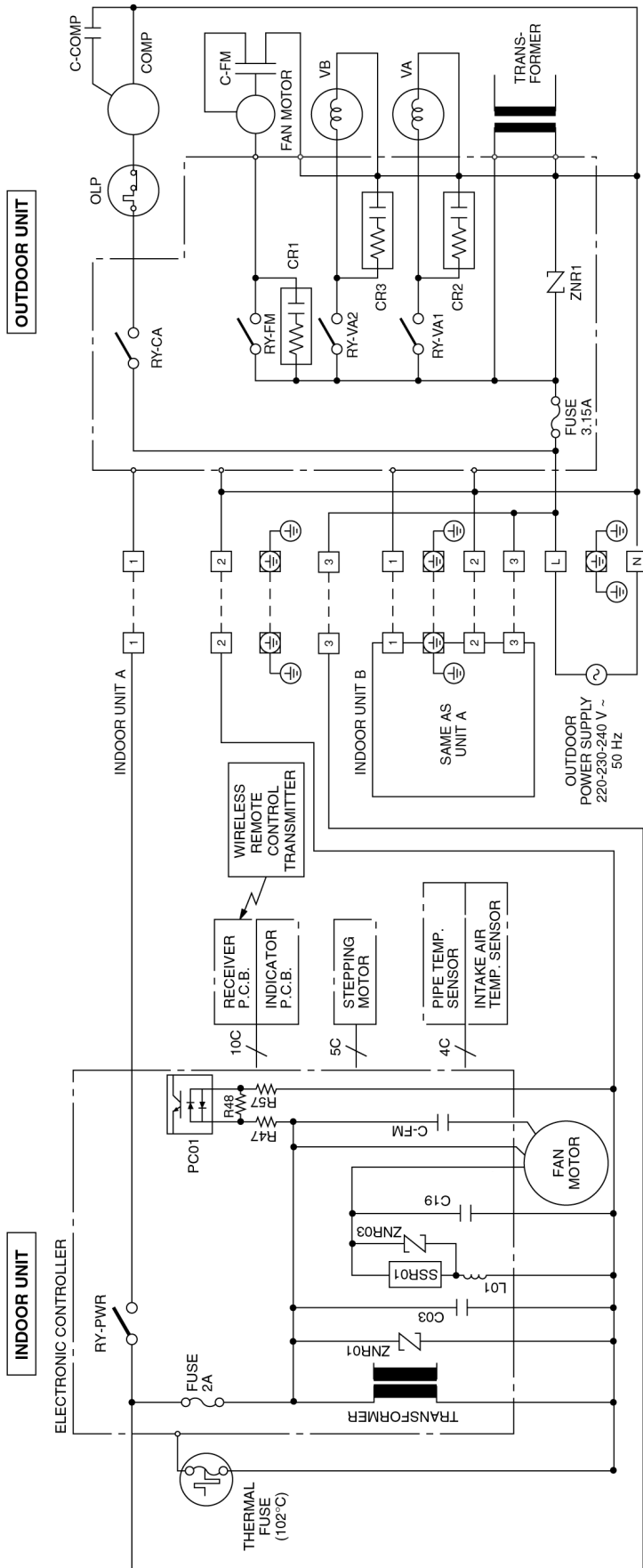

6 Block Diagram

CS-C9BK / CU-2C14BK



 Indicates the electronic control unit.
 "C" Indicates the number of core wires. (Example: 6C=6 core wires)

CS-C9BK / CU-2C18BK

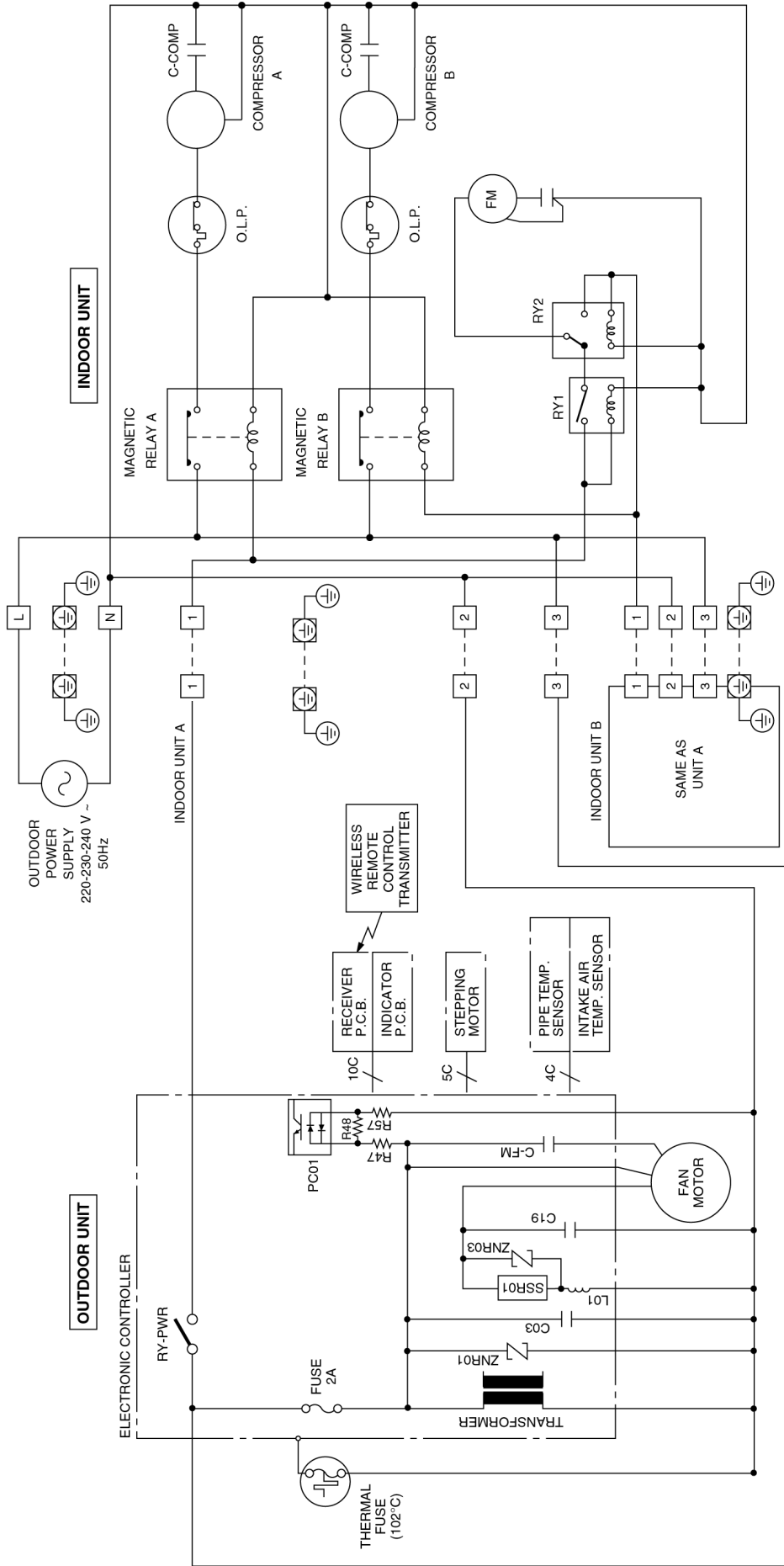

⊞ Indicates the electronic control unit.
 ⊞ "C" Indicates the number of core wires. (Example: 6C=6 core wires)

CS-C9BK / CU-3C20BK

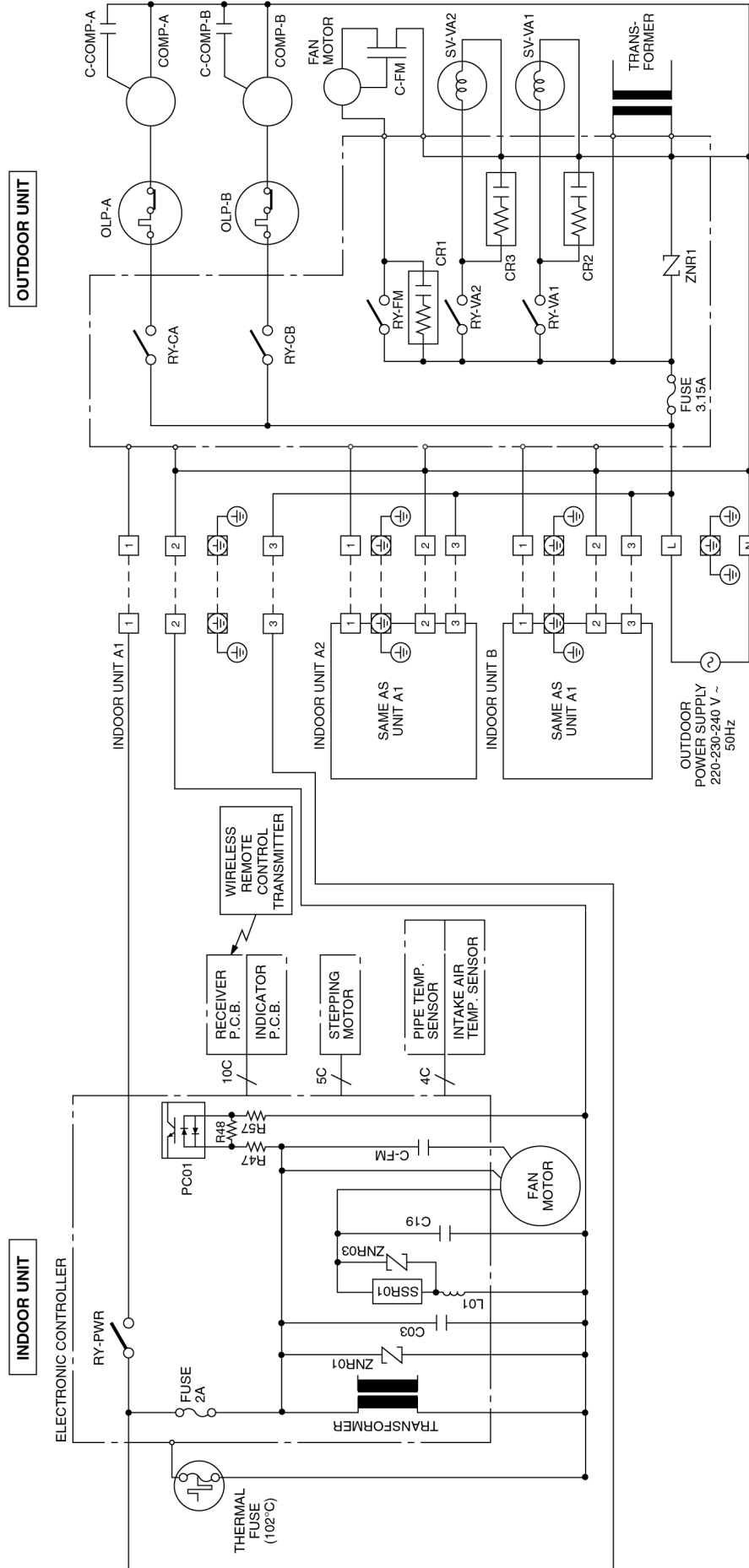

✱ [] Indicates the electronic control unit.

✱ *C Indicates the number of core wires. (Example: 6C=6 core wires)

CS-C7BK, CS-C12BK / CU-2C19BK

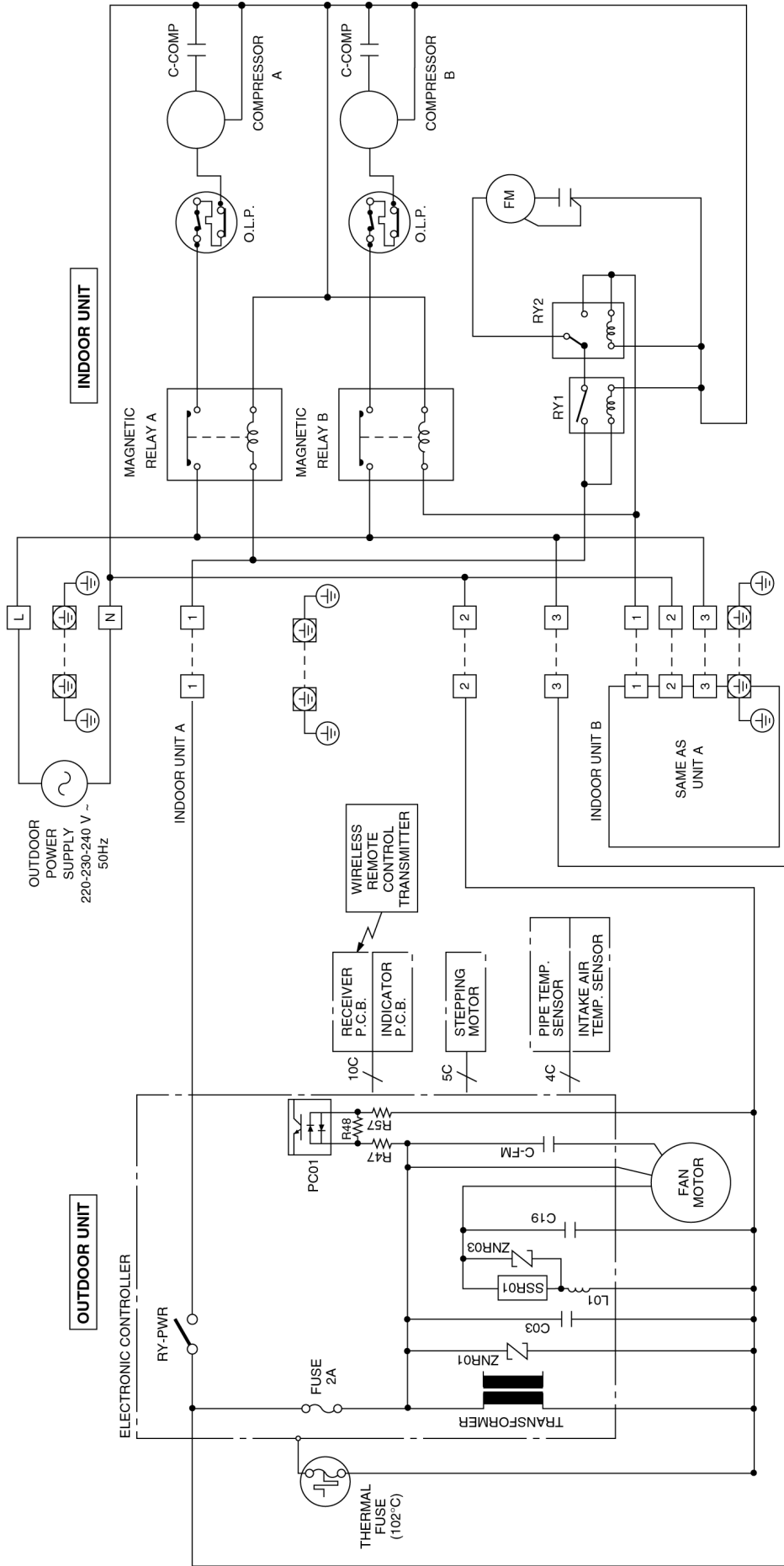

⊠ Indicates the electronic control unit.
 ✖✖ "C" Indicates the number of core wires. (Example: 6C=6 core wires)

7 Wiring Diagram

CS-C9BK / CU-2C14BK

Remarks:

- B : BLUE
- BR : BROWN
- BL : BLACK
- W : WHITE
- R : RED
- O : ORANGE
- P : PINK
- Y/G : YELLOW / GREEN
- GRY : GRAY

Resistance of Indoor Fan Motor Windings

CONNECTION	CWA921060 (Ω)
YELLOW - BLUE	371.0
YELLOW - RED	388.6

Resistance of Outdoor Fan Motor Windings

CONNECTION	CWA95374 (Ω)
BLUE - YELLOW	446.1
YELLOW - RED	474.6

Resistance of Compressor Windings

CONNECTION	2PS192D2AA02 (Ω)
C - R	3.19
C - S	5.30

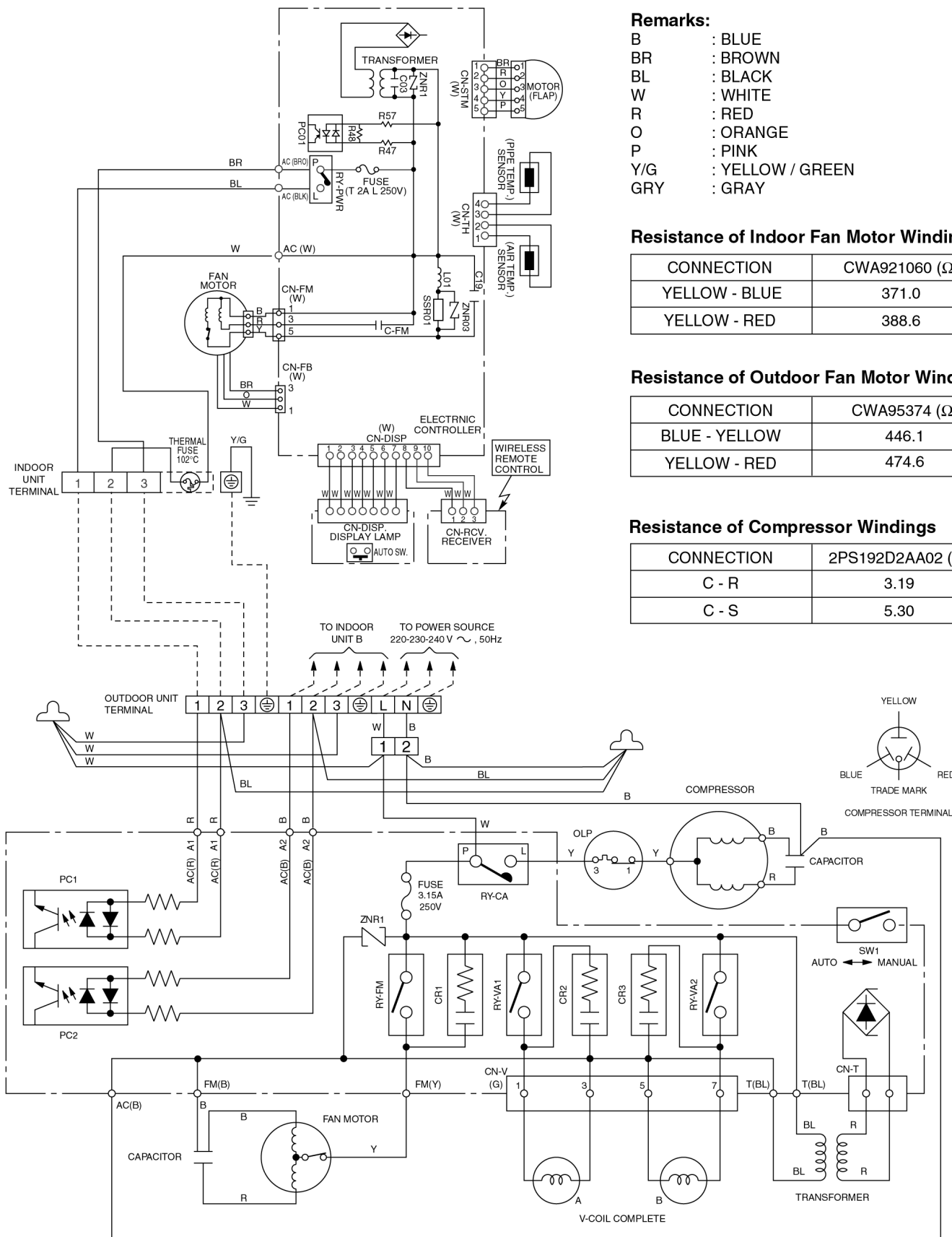

CS-C9BK / CU-2C18BK

Remarks:

- B : BLUE
- BR : BROWN
- BL : BLACK
- W : WHITE
- R : RED
- O : ORANGE
- P : PINK
- Y/G : YELLOW / GREEN
- GRY : GRAY

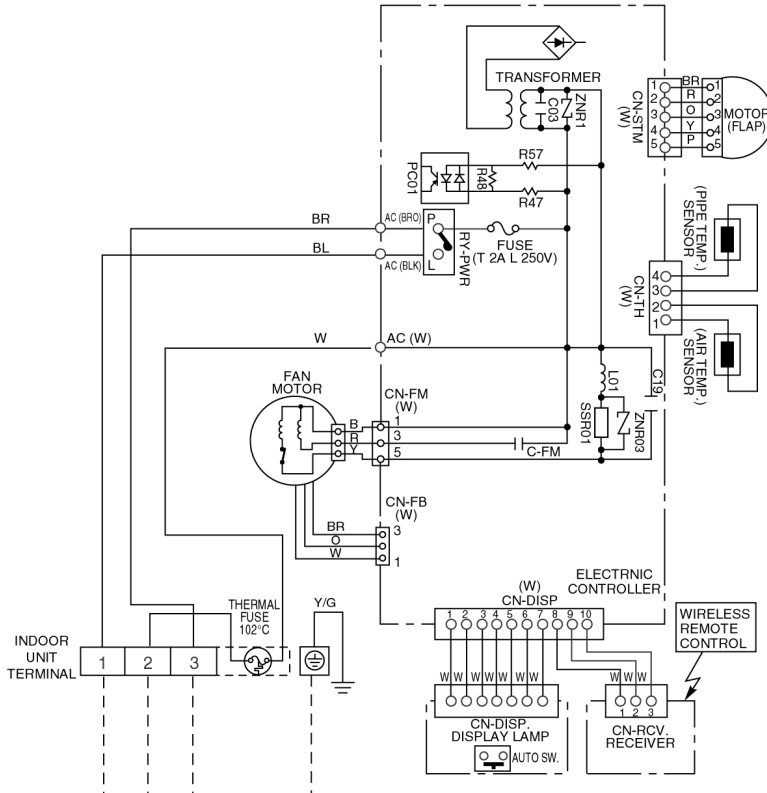

Resistance of Indoor Fan Motor Windings

CONNECTION	CWA921060 (Ω)
YELLOW - BLUE	371.0
YELLOW - RED	388.6

Resistance of Outdoor Fan Motor Windings

CONNECTION	CWA951179 (Ω)
BLUE - YELLOW	71.1
YELLOW - RED	96.9

Resistance of Compressor Windings

CONNECTION	2PS134D2AA01 (Ω)
C - R	4.20
C - S	4.95

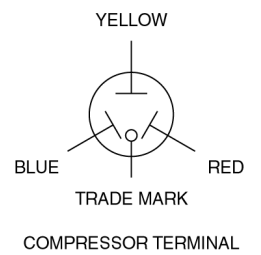
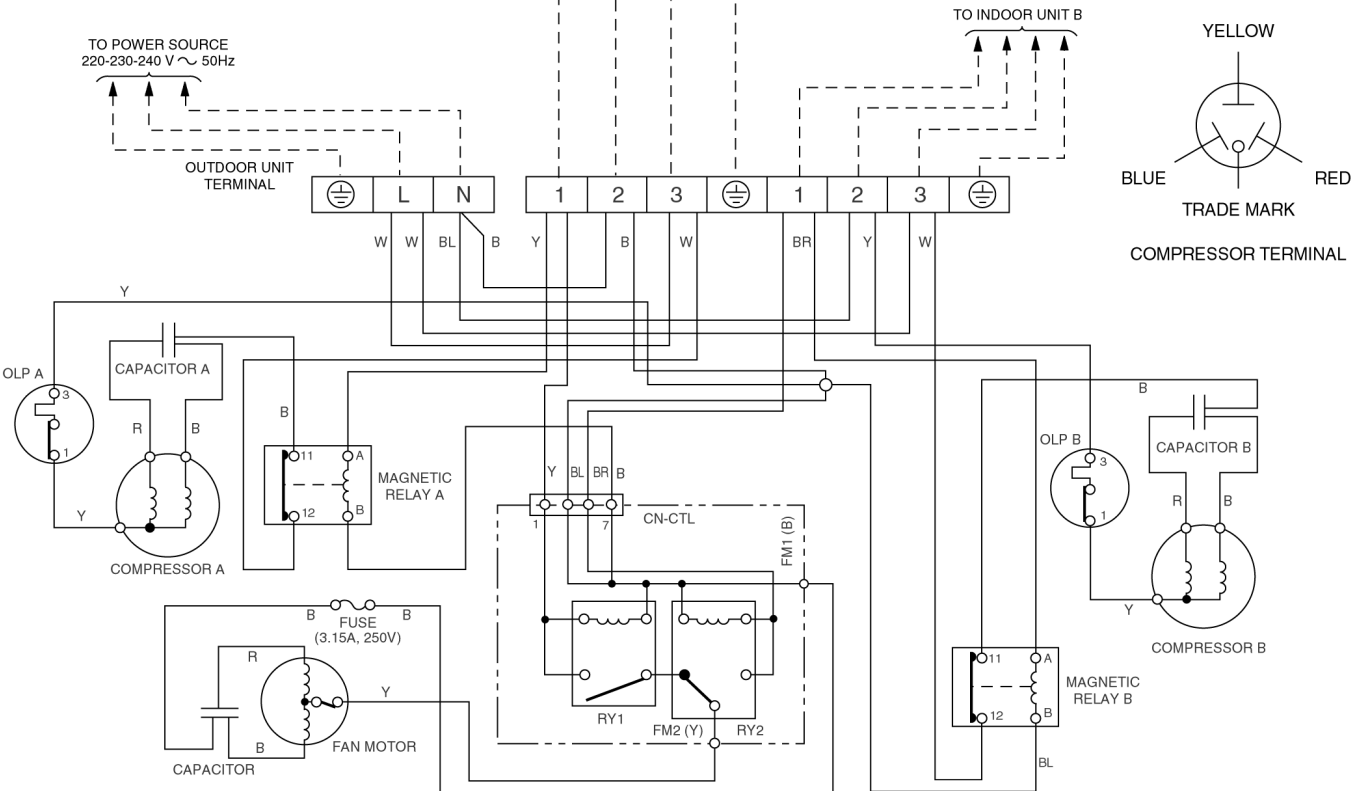

CS-C9BK / CU-3C20BK

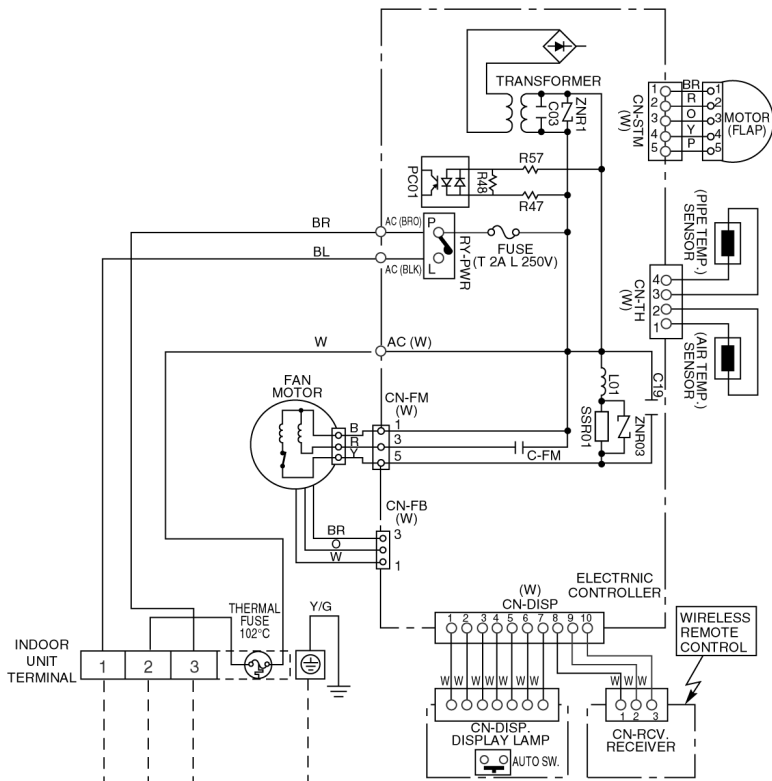

Remarks:

- B : BLUE
- BR : BROWN
- BL : BLACK
- W : WHITE
- R : RED
- O : ORANGE
- P : PINK
- Y/G : YELLOW / GREEN
- GRY : GRAY

Resistance of Indoor Fan Motor Windings

CONNECTION	CWA921060 (Ω)
YELLOW - BLUE	371.0
YELLOW - RED	388.6

Resistance of Outdoor Fan Motor Windings

CONNECTION	CWA951179 (Ω)
BLUE - YELLOW	71.1
YELLOW - RED	96.9

Resistance of Compressor Windings

CONNECTION	2PS134D2AA01 (Ω)
C - R	4.20
C - S	4.95

CONNECTION	2PS193D2AA01 (Ω)
C - R	3.19
C - S	5.30

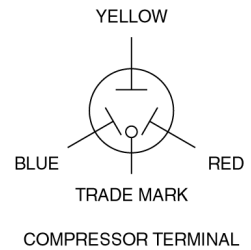
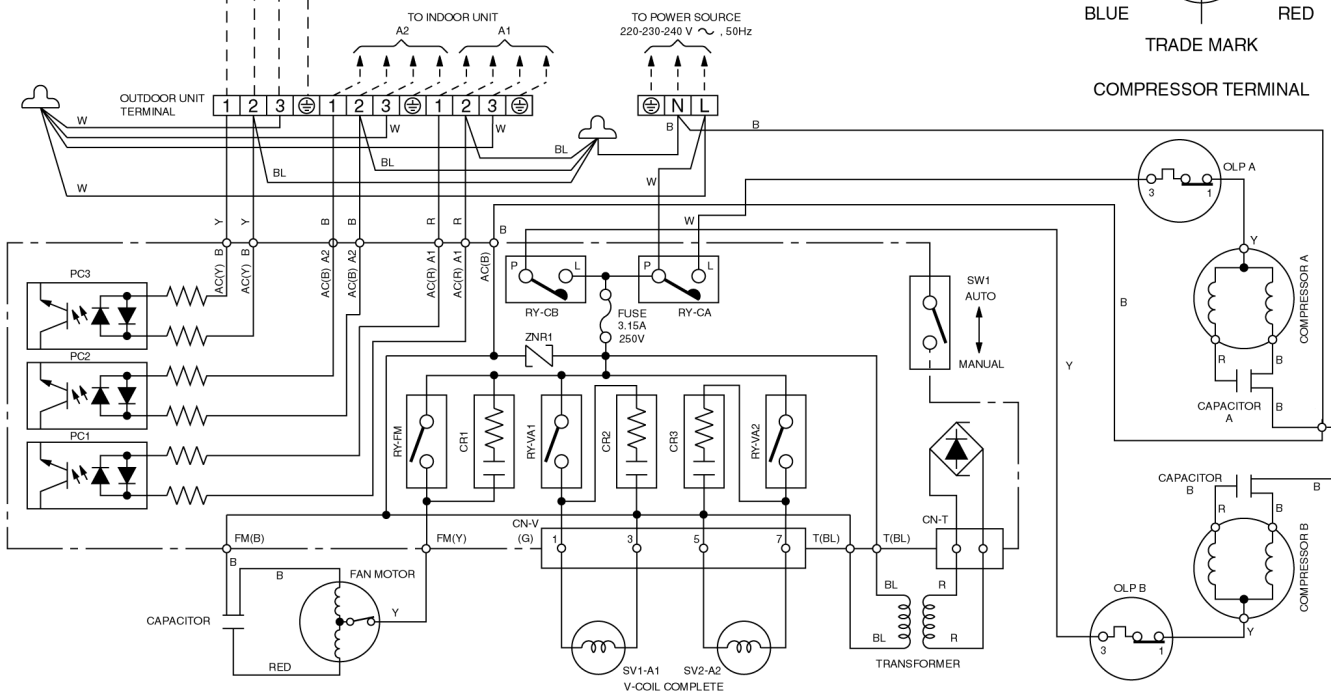

CS-C7BK, CS-C12BK / CU-2C19BK

Remarks:

- B : BLUE
- BR : BROWN
- BL : BLACK
- W : WHITE
- R : RED
- O : ORANGE
- P : PINK
- Y/G : YELLOW / GREEN
- GRY : GRAY

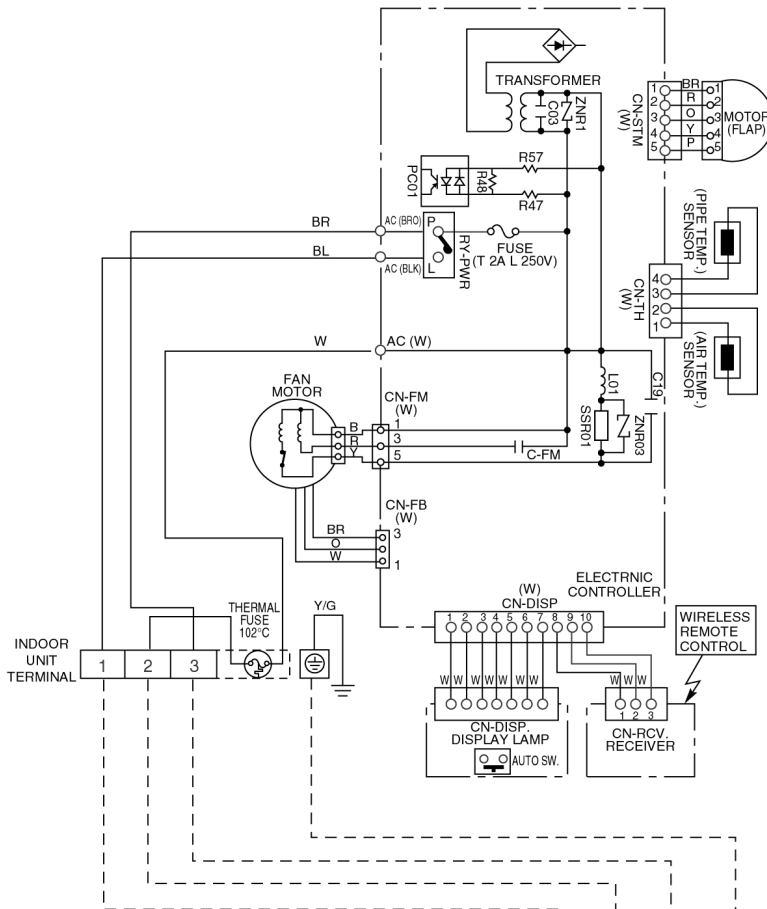

Resistance of Indoor Fan Motor Windings

CONNECTION	CWA921060 (Ω)
YELLOW - BLUE	371.0
YELLOW - RED	388.6

Resistance of Outdoor Fan Motor Windings

CONNECTION	CWA951179 (Ω)
BLUE - YELLOW	71.1
YELLOW - RED	96.9

Resistance of Compressor Windings

CONNECTION	2RS127D3CA04 (Ω)
C - R	4.023
C - S	8.803

CONNECTION	2KS224D5CA02 (Ω)
C - R	2.211
C - S	2.924

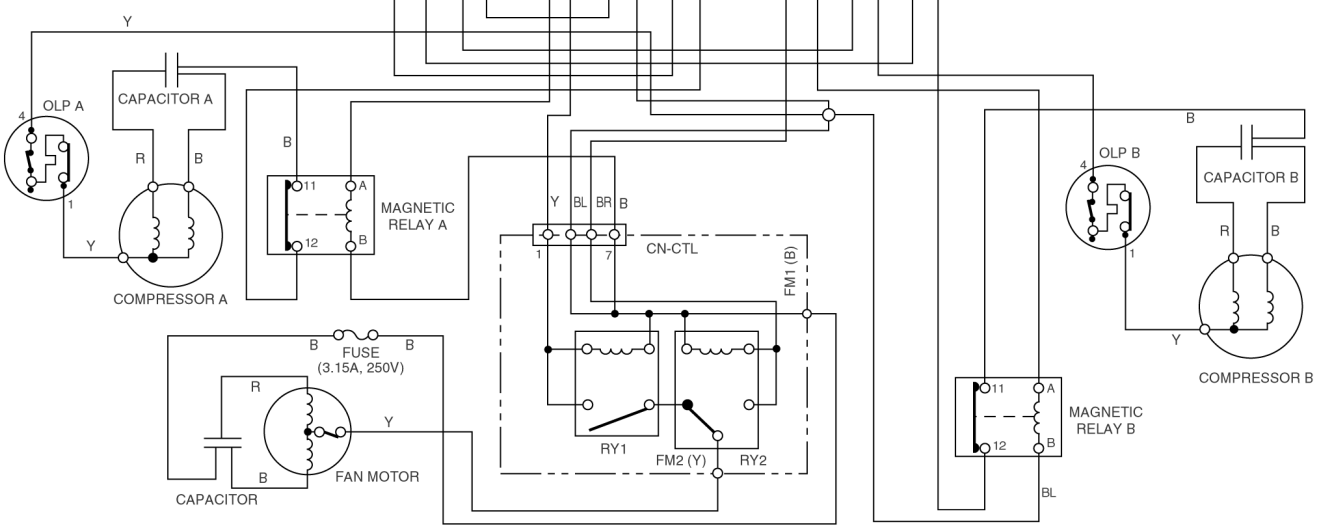
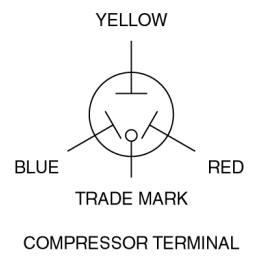
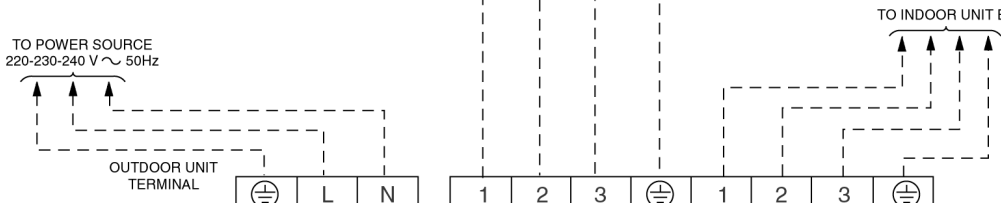

8 Operation Details

8.1. Cooling Mode Operation

Cooling in operation according to Remote Control setting.

Time Delay Safety Control (3 minutes)

- When the compressor is stopped by Remote Control, it restarts after 3 minutes when the Remote Control is turned ON.
- When the setting temperature is reached during cooling operation, the compressor stops and it will not start for 3 minutes.

7 minutes Time Save Control

- The compressor will start automatically if it has stopped for 7 minutes even if the room temperature is between the compressor ON temperature and OFF temperature.

Starting Current Control

- When the compressor outdoor fan motor and indoor fan motor are simultaneously started, the indoor fan motor will operate 1.6 second later.

Anti-Freezing Control

- If the temperature of the indoor heat exchanger falls continuously below 2°C for 4 minutes or more, the compressor turns off to protect the indoor heat exchanger from freezing. The fan speed setting remains the same.
- Compressor will restart again when the indoor heat exchanger temperature rises to 10°C (Recovery).

⊗ 3 minutes waiting of Time Delay Safety Control is valid for Cooling Operation.

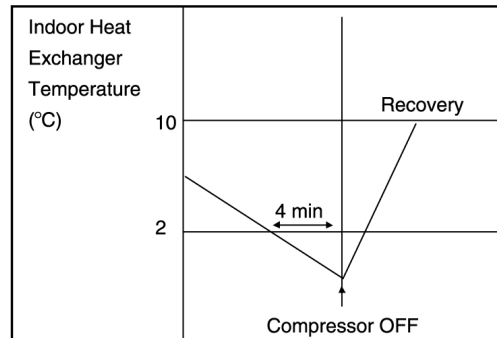

Compressor Reverse Rotation Protection Control

- If the compressor is operating continuously for 5 minutes or longer and the temperature difference between intake air and indoor heat exchanger is 2.5°C or less for 2 minutes, compressor will stop and restart automatically. (Time Delay Safety Control is valid)



▲ T = Intake air temperature - Indoor heat exchanger temperature

This is to protect reverse rotation of the compressor when there is a instantaneous power failure.

Anti-Dew Formation Control

- Purpose is to prevent dew formation on indoor unit air discharge area.
- When the following conditions occur for 30 minutes continuously, anti-dew formation is controlled by indoor fan speed shift to low (CLo to HLo):
 - Indoor intake air temperature is more than 24°C and less than 30°C.
 - Remote Control setting temperature is less than 25°C.
 - Compressor is on.
 - Cooling operation mode.
 - Indoor Fan motor operate at Low fan speed.
- This control is cancelled immediately when above condition is changed.

Automatic Fan Speed Mode

When Automatic Fan Speed is selected at Remote Control during cooling operation.

- Fan speed rotates in the range of Hi to Me.
- Deodorizing Control.

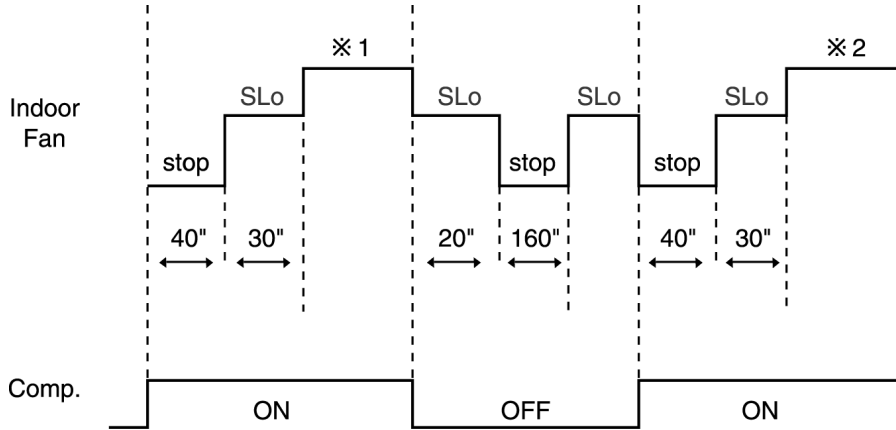

- ※ 1 Fan Speed is Hi until the compressor stops (when the room temperature reaches setting temperature).
- ※ 2 Fan Speed is Me after the compressor restarts.

Cooling Operation Time Diagram

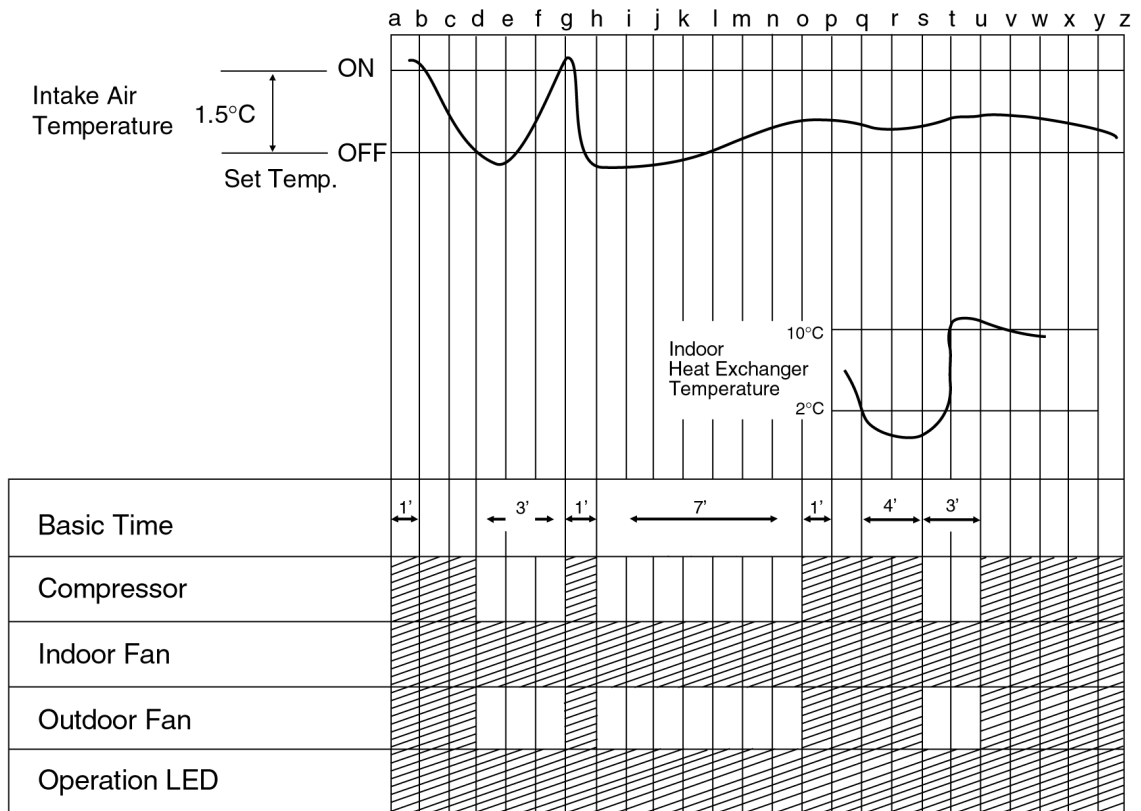

<Description of operation>

- d – g : Time Delay Safety Control (waiting for 3 minutes)
- g – h : 60 sec. Forced Operation
- h – o : 7 min. Time Save Control
- q – u : Anti Freezing Control

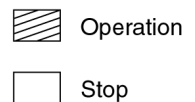

8.2. Soft Dry Mode Operation

- The unit starts cooling operation until the room temperature reaches the setting temperature set on the Remote Control, and then Soft Dry operation will start.
- During Soft Dry operation, the Indoor Fan will operate at SLo speed.
- The operation will be switched on and off for up to 10 minutes "ON" and 6 minutes "OFF". Once Soft Dry operation is turned off, it stops for 6 minutes.

Time Delay Safety Control

- Once the compressor stops, it will not start for 3 minutes during Cooling operation.

Starting Current Control

- Same as Starting Current Control for Cooling Mode operation.

Anti-Freezing Control

- Same as Anti-Freezing Control for Cooling Mode operation. (For Soft Dry region, 6 minutes waiting is valid during compressor stops.)

Compressor Reverse Rotation Protection Control

- Same as Compressor Reverse Rotation Protection Control for Cooling Mode Operation. (For Soft Dry region, 6 minutes waiting is valid during compressor stops.)

Anti-Dew Formation Control

- Same as Anti-Dew Formation Control for Cooling Mode operation.

Automatic Fan Speed Mode

When Automatic Fan Speed is selected at Remote Control during Soft Dry operation.

- Fan speed off and on at SLo speed.
- Deodorizing Control.

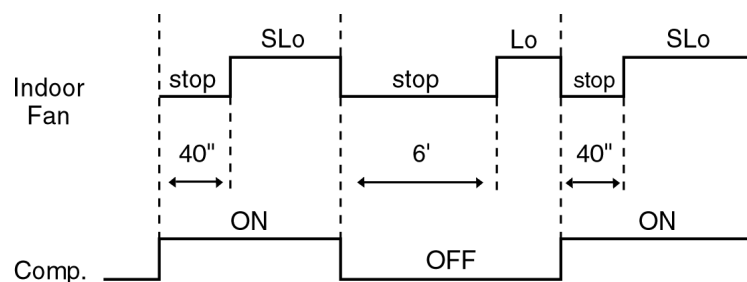

Soft Dry Operation Time Diagram

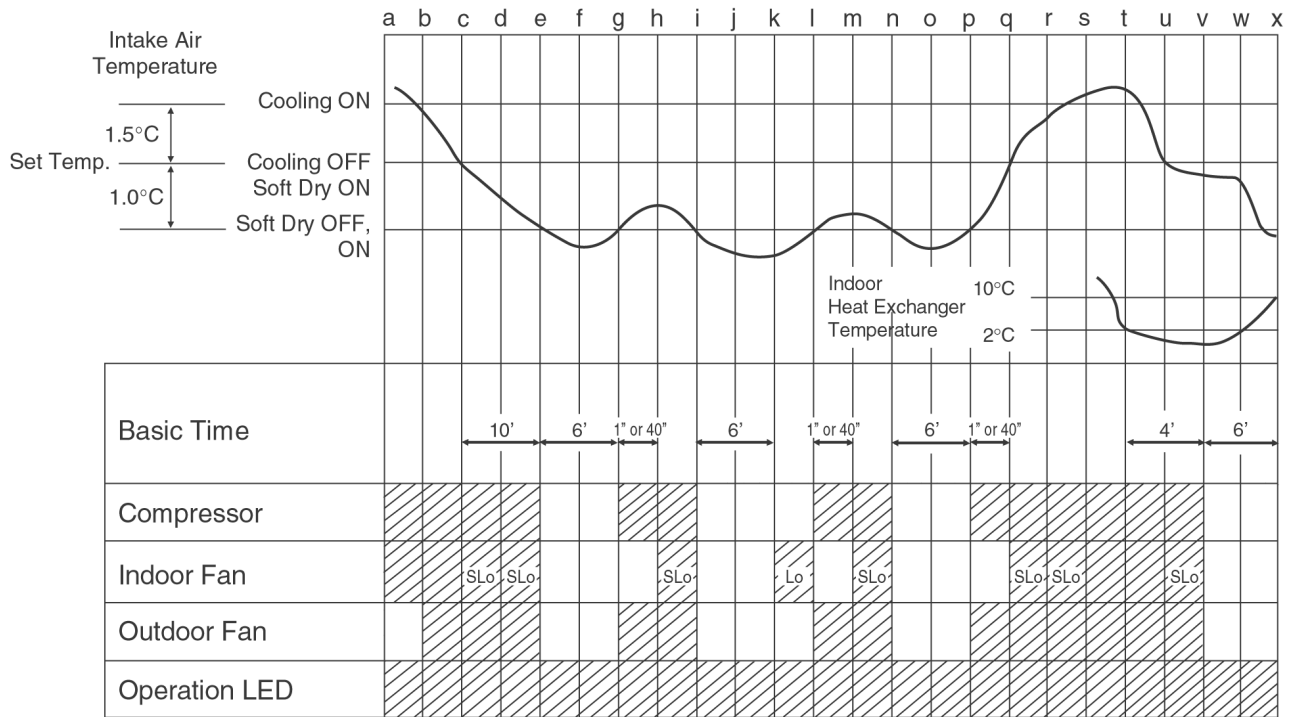

<Description of operation>

- a – c : Cooling Operation
- c – s : Soft Dry Operation
- e – g : Soft Dry OFF
- l – m : 60 sec. Forced Operation
- t – x : Anti Freezing Control

 Operation
 Stop

8.3. Air Circulation Mode Operation

- When the temperature near the ceiling reaches the setting temperature, Air Circulation Mode operation commences at low airflow volume. It stops when the temperature drops to 2°C below the setting temperature.

Air Circulation Mode Operation Time Diagram

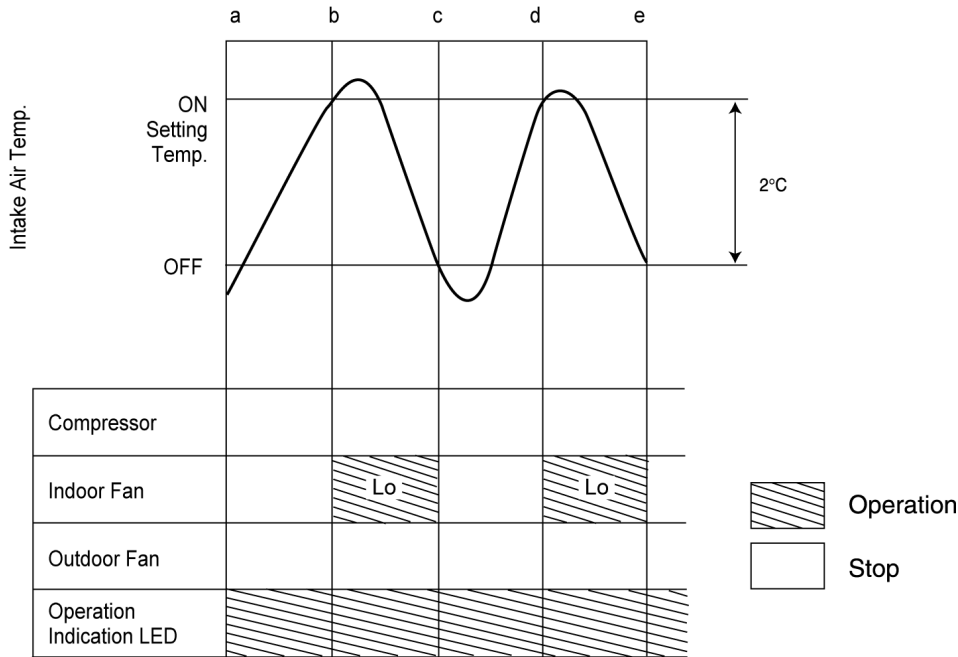

8.4. Automatic Mode Operation

Standard for Determining Operation Mode

↑
Intake Air Temperature

23°C | Cooling Mode
Soft Dry Mode

	Setting Temperature (Standard)
Cooling Mode	25°C
Soft Dry Mode	22°C

- Indoor fan operates at SLo fan speed for 25 seconds.
- After judging indoor air temperature, the operation mode is determined and operation continued at the mode determined.
- After the operation mode has been determined, the mode does not change. However, Soft Dry mode operation includes Cooling mode operation.
- Room temperature adjustment.

The following are added to the setting temperature specified as above.

	Cooling	Soft Dry
Higher → +2°C	27°C	24°C
Standard → ±0°C	25°C	22°C
Lower → -2°C	23°C	20°C

- The mode judging temperature and standard setting temperature can be increased by 2°C, by open the circuit of JX1 at indoor electronic controller.

↑
Intake Air Temperature

25°C | Cooling Mode
Soft Dry Mode

	Setting Temperature (Standard)
Cooling Mode	27°C
Soft Dry Mode	24°C

8.5. Sleep Mode Auto Operation

Cooling or Soft Dry Operation

Purpose is to obtain a comfortable room temperature while sleeping. When you press the SLEEP Mode, the following movement will start to avoid overcooling.

- Sleep shift operation starts, when the room temperature reaches the setting temperature or after 1 hour of operation.
- The setting temperature will be risen by 0.5°C at the start of operation and by 0.5°C one hour later.
- The airflow volume will automatically change to Lo fan speed.
- Sleep Mode operation time is 8 hours, the operation will be stop after 8 hours.
- When used together with the Timer, the Timer has priority.

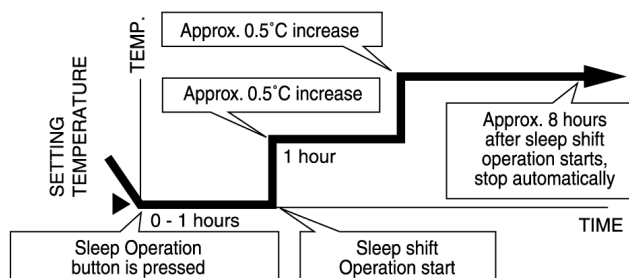

8.6. Powerful Mode Operation

- Purpose of this operation is to obtain the setting temperature quickly.
- When the Powerful Mode is set, the set temperature will be automatically decreased 3°C against the present setting temperature (Lower temperature: 16°C).
- This operation automatically will be running under SHi Fan Speed (Cooling), SLo Fan Speed (Soft Dry).
- Vertical Airflow Direction:-
 - In "Manual" setting, the vane will automatically swing down 10° lower than previous setting.
 - In "Auto" setting, the vane will automatically swing up and down. However the lower limit will be shifted 10° downward.
- Powerful Mode will operate for 15 minutes only, after that it will shift back to previous operation mode.
- Powerful Mode will stop if:-
 - Powerful mode button is pressed again.
 - Stopped by ON / OFF switch.
 - Timer OFF activates.
 - Economy mode button is pressed.
 - Sleep mode is pressed.
 - Operation mode button is changed.

8.7. Economy Mode Operation

- Purpose of this operation is to save or reduced electrical power consumption of the room air conditioner.
- When the Economy Mode is set, the set temperature will be automatically increased 0.5°C against the preset setting temperature (Higher temperature: 30°C).
- This operation automatically will be running under SLo Fan Speed.
- Vertical Airflow Direction:-
 - In "Manual" or "Auto" setting, the vane will automatically change to Auto Air Swing.
- Economy Mode will stop if:-
 - Economy Mode button is pressed again.
 - Stopped by ON / OFF switch.
 - Timer OFF activates.
 - Powerful mode button is pressed.
 - Auto or Manual air swing button is pressed.
 - Fan Speed control button is pressed.
 - Sleep Mode button is pressed ON.
 - Operation Mode is changed.

8.8. Random Auto Restart Control

- If there is a power failure, operation will be automatically restarted after 3 to 4 minutes when the power is resumed.
It will start with previous operation mode and airflow direction.
- Restart time is decided randomly using 4 parameter:-
Intake air temperature, setting temperature, fan speed and Air Swing Blade position.
- Auto Restart Control is not available when Timer or Sleep Mode is set.
- This control can be omitted by open the circuit of JX2. (Refer Circuit Diagram)

8.9. Indoor Fan Speed Control

- Auto Fan Speed Control
When set to Auto Fan Speed, the fan speed is adjusted between maximum and minimum setting as shown in the table.
- Manual Fan Speed Control
Basic fan speed adjustment (3 settings, from Lo to Hi) can be carried out by using the Fan Speed selection button at the remote control.

		Tap	S Hi	Hi	Me	H Lo	C Lo	Lo-	S Lo	SSLo	Stop
Cooling	Normal	Manual	Hi	○							
			Me		○						
			Lo				○	○			
		Air volume auto		○	○				○		
		Sleep shift					○				
	Powerful	Manual	○								
		Air volume auto	○								
		Sleep shift					○				
	Economy	Manual							○		
		Air volume auto							○		
Sleep shift						○					
Dry	Normal Powerful Economy	Manual, Air volume auto							○		○
		Sleep shift					○				
Air circulation		Normal					○				
Auto Mode judgement									○		

	Cooling			Soft dry (dry area)			Air circulation
	Normal	Powerful	Economy	Normal	Powerful	Economy	Normal
Normal Operation	Control by remote controller	S Hi	S Lo	S Lo	S Lo	S Lo	C Lo
Sleep mode	C Lo	C Lo	C Lo	C Lo	C Lo	C Lo	-
Preliminary operation (On timer)	Control by remote controller	-	-	S Lo	-	-	-

8.10. Vertical Airflow Direction Control

Vertical Airflow Direction Auto-Control

- When set a Airflow Direction Auto-Control with remote control, the louver swings up and down as shown in the diagram.
- The louver does not swing when the Indoor Fan Motor stops during operation at the upper limit.
- When stopped with remote control, the discharge vent is reset, and stopped at the closing position.

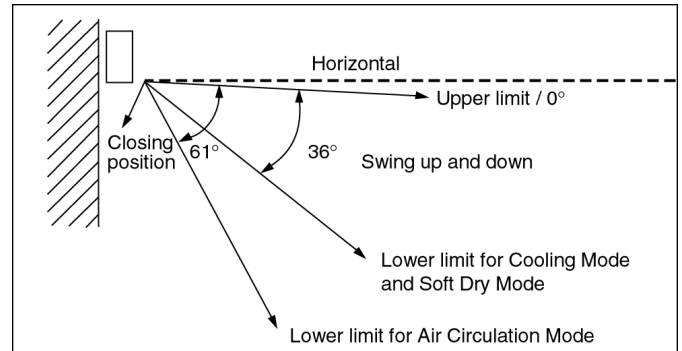

✘ The left and right airflow direction louvers can be adjusted manually.

- ✘ 1. There is no swinging while indoor fan motor is stopped during Cooling and Soft Dry operation.
- ✘ 2. In Air Circulation operation, when the intake air temperature reaches set temperature, the airflow direction is changed from upper limit to lower limit. When the intake air temperature falls to 2°C lower than set temperature, the airflow direction is changed from lower limit to upper limit.

Vertical Airflow Direction manual Control

- When the manual Airflow Direction Selection Button is pressed, the automatic airflow is released and the airflow direction louver move up and down in the range shown in the diagram.
The louver can be adjusted by pressing the button to the desired louver position.
- When the remote control is used to stop the operation, the discharge vent is reset, and stopped at the closing position.

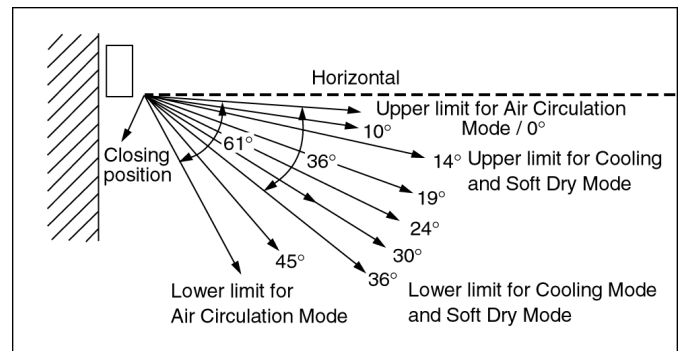

✘ The left and right airflow direction louvers can be adjusted manually.

8.11. Delay ON Timer Control

- When the Delayed ON Timer is set by using the remote control, the unit will start operate slightly before the set time, so that the room will reach nearly to the set temperature by the desired time.
- For Cooling and Soft Dry mode, the operation will start 15 minutes before the set time.
- For Automatic mode, the indoor fan will operate at SLo speed for 25 seconds, 15 minutes before the set time to detect the intake air temperature to determine the operation mode. The operation indication lamp will blink at this time.

8.12. Remote Control Signal Receiving Sound

- Long beep sound will be heard when:-
 - Stopping the Air Conditioner using ON/OFF switch.
 - Stopping the Sleep Mode.
 - Stopping the Powerful Mode.
 - Stopping the Economy Mode.
- Short beep sound will be heard for others.
- To switch off the beep sound:-
Press the “Automatic Operation Button” continuously for 10 seconds or more (“beep” “beep” will be heard at the 10th second). Repeat the above if you want to switch ON the beep sound.

- ✘ However, if the “Automatic Operation Button” has been pressed the Automatic operation will be activated. If you do not require this operation, you may change it by using the remote control.

9 Operating Instructions

SAFETY PRECAUTIONS

Before operating, please read the following "Safety Precautions" carefully.

- To prevent personal injury, injury to others and property damage, the following instructions must be followed.
- Incorrect operation due to failure to follow instructions will cause harm or damage, the seriousness of which is classified as follow:



This sign warns of death or serious injury.



This sign warns of damage to property.

- The instructions to be followed are classified by the following symbols:



This symbol (with a white background) denotes an action that is PROHIBITED.



These symbols (with a black background) denote actions that are COMPULSORY.

Installation Precautions



- **Do not install, remove and reinstall the unit by yourself.**
Improper installation will cause leakage, electric shock or fire. Please engage an authorized dealer or specialist for the installation work.

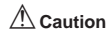

- **This room air conditioner must be earthed.**
Improper grounding could cause electric shock.
- **Ensure that the drainage piping is connected properly.**
Otherwise, water will leak out.
- **Do not install the unit in a potentially explosive atmosphere.**
Gas leak near the unit could cause fire.

Operation Precautions



This sign warns of death or serious injury.

- Do not share outlet.
- Do not operate with wet hands.
- Do not damage or modify the power cord.
- Do not insert finger or other objects into the indoor or outdoor units.
- Do not expose directly to cold air for a long period.



- Use specified power cord.



- If abnormal condition (burnt smell, etc.) occurs, switch off the power supply.



This sign warns of injury.



- Do not wash the unit with water.
- Do not use for other purposes such as preservation.
- Do not use any combustible equipment at airflow direction.
- Do not sit or place anything on the outdoor unit.



- Switch off the power supply before cleaning.
- Ventilate the room regularly.
- Pay attention as to whether the installation rack is damaged after long period of usage.



- Switch off the power supply if the unit is not used for a long period.

NAME OF EACH PART

Indoor Unit

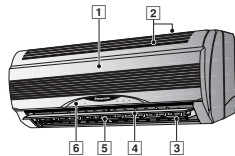

- 1 Front Panel
- 2 Air Intake Vent
- 3 Air Outlet Vent
- 4 Vertical Airflow Direction Louver
- 5 Horizontal Airflow Direction Louver (manually adjusted)
- 6 Indicator Panel

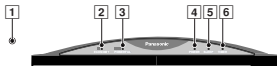

- 1 Auto Operation Button (when the front panel is opened)
- 2 Economy Mode Indicator - GREEN
- 3 Powerful Mode Indicator - ORANGE
- 4 Power Indicator - GREEN
- 5 Sleep Mode Indicator - ORANGE
- 6 Timer Mode Indicator - ORANGE

Indoor Unit (when the front panel is opened)

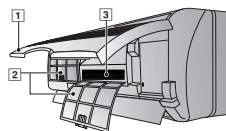

- 1 Front Panel
- 2 Air Filters
- 3 Air Purifying Filter

Outdoor Unit

CU-2C18BKP5G
CU-2C19BKP5G

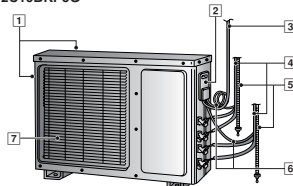

CU-2C14BKP5G



- 1 Air Intake Vents
- 2 Ground Terminal (Inside cover)
- 3 Power Supply Cord
- 4 Piping

CU-3C20BKP5G



- 5 Drain Hose
- 6 Connecting Cable
- 7 Air Outlet Vents

Accessories

Remote Control



Remote Control Indication Sticker

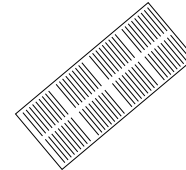

Remote Control Holder

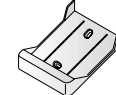

Two R03 (AAA) dry-cell batteries or equivalent



Air Purifying Filter

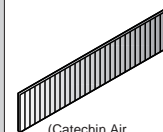

(Catechin Air Purifying Filter)

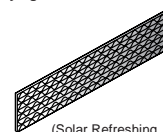

(Solar Refreshing Deodorizing Filter)

NAME OF EACH PART

■ Remote Control

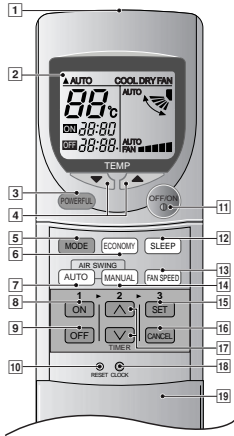

● Remote Control Signal.

- Make sure it is not obstructed.
- Maximum distance : 10 m.
- Signal received sound.
- One short beep or one long beep.

● Notes for Remote Control.

- Do not throw or drop.
- Do not get it wet.
- Certain type of fluorescent lamps may affect signal reception. Consult your dealer.

- 1 Signal Transmitter
- 2 Operation Display
- 3 Powerful Mode Operation Button
- 4 Room Temperature Setting Button (self-illuminating button)
- 5 Operation Mode Selection Button
- 6 Economy Mode Operation Button
- 7 Auto Airflow Direction Button
- 8 ON-Timer Button
- 9 OFF-Timer Button
- 10 Reset Point (Press with fine-tipped object to clear the memory)
- 11 OFF/ON Button (self-illuminating button)
- 12 Sleep Mode Operation Button
- 13 Fan Speed Selection Button
- 14 Manual Airflow Direction Selection Button
- 15 Timer Set Button
- 16 Timer Cancellation Button
- 17 Time-Setting Button
- 18 Clock Button
- 19 Remote Control Cover

● How to Insert the Batteries

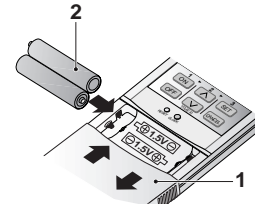

1 Slide down the remote control cover completely

2 Insert the batteries

- Be sure the direction is correct
- 12.00 at display - flashing
- Set the current time (CLOCK) immediately to prevent battery exhaustion.

● About the batteries

- Can be used for approximately one year.

● Observe the following when replacing the batteries

- Replace with new batteries of the same type.
- Do not use rechargeable batteries (Ni-Cd).
- Remove the batteries if the unit is not going to be used for a long period.

PREPARATION BEFORE OPERATION

■ Indoor Unit

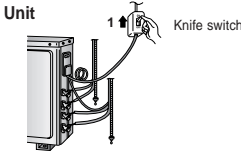

1 Set the knife switch to "ON"

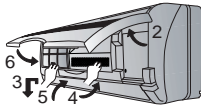

- 2 Open the front panel
- 3 Remove the air filters
- 4 Fit the air purifying filters in place
- 5 Insert the air filters
- 6 Close the front panel

■ Remote Control

- To set the current time

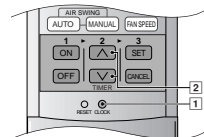

- 1 Press [1].
 - 2 Then press [2] to increase or decrease the time.
 - 3 Press [1] again.
- Set time at display will light up.

HOW TO OPERATE

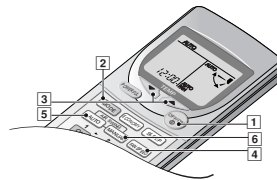

■ To start the operation

- Press [1].
- POWER indicator (green) on the indoor unit will light up.
- To stop, press once more.

■ Setting Mode

- Press [2] to select-

- AUTO - Automatic Operation
- COOL - Cooling Operation
- DRY - Soft Dry Operation
- FAN - Air Circulation Operation

■ Setting Temperature

- Press [3] to increase or decrease the temperature.
- The temperature can be set between 16°C ~ 30°C.
- Recommended temperature:

COOL	26°C ~ 28°C
DRY	1°C ~ 2°C lower than the room temperature

- During AUTO Operation, press [3] to select-



- Operation with 2°C higher than the standard temperature.
- Operation with the standard temperature.
- Operation with 2°C lower than the standard temperature.

● Standard Temperature

Indoor temperature	Operation	Standard temperature
23°C	Cooling	25°C
	Soft Dry	22°C

- Once the Automatic Operation is selected, the indoor temperature sensor operates automatically to select the desired operation mode with Cooling or Soft Dry.
- After the operation mode has been selected, the mode does not change.

■ Setting the Fan Speed

• Press [4] to select:-

- FAN ■ - Low Fan Speed
- FAN ■ ■ ■ - Medium Fan Speed
- FAN ■ ■ ■ ■ ■ - High Fan Speed
- AUTO - Automatic Fan Speed

The speed of the indoor fan is adjusted automatically according to the operation. The indoor fan stops occasionally during cooling operation.

■ Setting the Vertical Airflow Direction

• Press [5] or [6] to select:-

COOL / DRY Operation

AUTO



Swing up/down Automatically

MANUAL

Five stages of adjustment can be made between 14° - 36°.

FAN Operation

AUTO



Swing up/down Automatically

MANUAL

Five stages of adjustment can be made between 0° - 61°.

■ Setting the Horizontal Airflow Direction

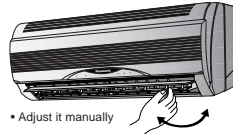

• Adjust it manually

• Use this air conditioner under the following conditions:

DBT: Dry Bulb Temp WBT: Wet Bulb Temp	Unit in °C			
	Indoor		Outdoor	
	DBT	WBT	DBT	WBT
Maximum Temperature	32	23	43	26
Minimum Temperature	16	11	16	11

• Notes

- If the unit is not going to be used for an extended period of time, turn off the main power supply. If it is left at the ON position, approximately 2.5 W of electricity will be used even if the indoor unit has been turned off with the remote control.
- If operation is stopped, then restart immediately, the unit will resume operation only after 3 minutes.

● Operation Details

COOL – Cooling Operation

- To set the room temperature at your preference cooling comfort.

AUTO – Automatic Operation

- Sense indoor temperature to select the optimum mode.
- Temperature is not displayed on the remote control during AUTO operation.

DRY – Soft Dry Operation

- A very gentle Cooling Operation, prior to dehumidification. It does not lower the room temperature.
- During Soft Dry operation, the indoor fan operates at Low fan speed.

FAN – Air Circulation Operation

- When the room temperature reaches the set temperature, operation commences at Low airflow volume. It stops when the room temperature drops to 2°C below the set temperature. (It is useful when using a heater).

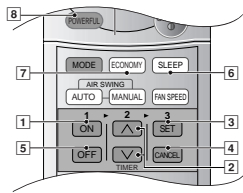

SETTING THE TIMER

Ensure that the current time is correct before setting the timer. The timer cannot be set if the time display is flashing.

■ ON-TIMER Operation

To start the air conditioner operation automatically.

- Press [1] to set the operation.
- Press [2] to increase or decrease the time.
- Then press [3].
- To cancel this operation, press [4].

■ OFF-TIMER Operation

To stop the air conditioner operation automatically.

- Press [5] to set the operation.
- Press [2] to increase or decrease the time.
- Then press [3].
- To cancel this operation, press [4].

● Timer Mode Operation Details

- When the ON-Timer is set, operation will start before the actual set time. This is to enable the room temperature reaches the set temperature at the set time.

COOL, DRY, AUTO	15 minutes in advance
-----------------	-----------------------

- Once the ON-Timer is set, operation will start at the set time everyday.
- The current time is not displayed when the timers are set.
- When both timers are used together, the TIMER mode indicator on the indoor unit remains lit even when the operation is stopped by the OFF-TIMER.

CONVENIENCE OPERATION

■ Sleep Mode Operation

To obtain a comfortable room temperature while sleeping:-

- Press [6].
- Sleep mode indicator on the indoor unit will light up.
- To cancel this operation, press once more.

● Sleep Mode Operation Details

- When the room temperature reaches the set temperature, the airflow volume will change to low automatically.
- Sleep Mode Operation time is 8 hours.
- When used together with the timer, the timer has a priority.

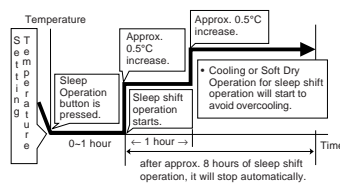

■ Economy Mode Operation

To save electrical power consumption. Please use this mode when the room has reached your desired temperature.

- Press [7].
- ✗ Economy mode indicator (green) on the indoor unit will light up.
- Press once more to cancel this operation.

■ Powerful Mode Operation

To obtain the set temperature quickly.

- Press [8].
- ✗ Powerful mode indicator (orange) on the indoor unit will light up.
- ✗ Powerful mode will operate for 15 minutes only.
- To cancel this operation, press once more.

● Economy / Powerful Mode Operation Details

- Economy and Powerful operation cannot be selected simultaneously.
- The changes of the temperature and airflow volume are automatic.
- The remote control display remains unchanged.
- If sleep button or operation mode button is pressed, economy or powerful operation will be cancelled.
- During FAN – Air circulation operation, the powerful and economy operation are not available.

Economy Mode Operation	Temperature	Airflow volume
COOL / DRY	0.5°C higher than set temp.	Super Low

Powerful Mode Operation	Temperature	Airflow volume
COOL / DRY	3°C lower than set temp.	Super High

CARE AND MAINTENANCE

■ Cleaning the Indoor Unit and Remote Control

- Wipe gently with a soft, dry cloth.
- Do not use water hotter than 40°C or polishing fluid to clean the unit.

■ Cleaning the Air Filter

(Recommendation:- If the unit is operated in a dusty environment, clean the filters every two weeks, continuous use of this dirty filters will reduce cooling efficiency)

- 1 Remove dirt using a vacuum cleaner.
 - 2 Wash back of the air filter with water.
 - 3 If badly soiled, wash it with soap or a mild household detergent.
 - 4 Let it dry and reinstall it.
Be sure the "FRONT" mark is facing you.
× Damaged air filter.
Consult the nearest authorized dealer.
Part No.: CWD001047.
- Do not use benzene, thinner, scouring powder or clothes soaked in caustic chemical to clean the unit.

■ Cleaning the Front Panel

(Must be removed before washing)

- 1 Raise the front panel higher than the horizontal and pull to remove it.
- 2 Gently wash with water and a sponge.
 - Do not press the front panel too hard when washing.
 - When use kitchen cleaning fluid (neutral detergent), rinse thoroughly.
 - Do not dry the front panel under direct sunlight.
- 3 To fix the front panel, raise the front panel horizontally, match the protruding portion on the indoor unit to the fulcrum and push into place.

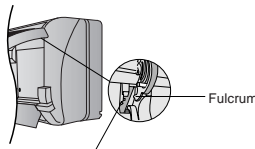

Protruding portion on indoor unit

■ Air Purifying Filters

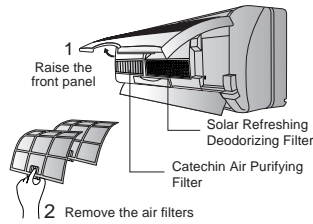

● Solar Refreshing Deodorizing Filter

- Used to remove unpleasant odour and deodorize the air in the room.
- Reusable.
- Vacuum, place under direct sunlight for 6 hours and fit it back in place.
(Recommended: every 6 months)

● Catechin Air Purifying Filter

- The filter is coated with catechin to prevent growth of bacteria and viruses.
- Reusable.
- Vacuum and fit it back in place
(Recommended: every 6 months)

- Recommended to change these filters every 3 years. Do not reuse damaged filters. Consult the nearest authorized dealer to purchase a new filter.
Catechin Air Purifying Filter No.: CZ-SF70P
Solar Refreshing Deodorizing Filter No.: CZ-SFD70P

- If you operate the air conditioner with dirty filters:-
 - Air is not purified
 - Cooling capacity decreases
 - Foul odour is emitted

■ Pre-season Inspection

● Is the discharged air cold?

Operation is normal if 15 minutes after the start of operation, the difference between the air intake and outlet vents temperature is:-

COOL – 8°C or above

● Are the air intake or outlet vents of the indoor or outdoor units obstructed?

● Are the remote control batteries weak?

If the remote control display appears weak, replace the batteries.

■ When the Air Conditioner is Not Used for an Extended Period of Time

- 1 To dry the internal parts of the indoor unit, operate the unit for 2 - 3 hours using:-

FAN operation

- 2 Stop the operation by remote control and switch off the knife switch.

Note: If the unit is not switched off by the remote control, it will start operating when the knife switch is switched to ON (because the unit is equipped with Auto Restart Control).

- 3 Remove the remote control batteries.

■ Recommended Inspection

- After used over several seasons, the unit will become dirty and thus decreases the unit's performance. Depending on the operation conditions, a dirty unit may produce odour and dust may pollute dehumidification system. Therefore, a seasonal inspection is recommended in addition to regular cleaning. (Consult an authorized dealer).

HELPFUL INFORMATION

■ Auto Operation Button

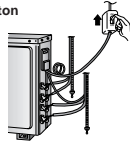

• Confirm the knife switch at "ON"



• Raise the front panel and press

● Automatic Operation

- If the remote control fails to function or has been misplaced, press the Auto Operation button to start the Automatic operation.
- The Automatic operation will be activated immediately once the Auto operation button is pressed. However, temperature cannot be adjusted in this operation.
- The power indicator on the indoor unit will blink until the operation mode is selected automatically.
- To cancel this operation, press once more.

● Remote Control Signal Receiving Sound

- To switch off the beep (Signal Receiving Sound), press the Auto Operation button for 10 seconds continuously or longer.
"Beep", "beep" sound will be heard at the tenth seconds.
Note: "Beep" sound will be heard at the fifth seconds;
However please press continuously until you heard "beep", "beep" sound.
- Repeat the above steps if you want to switch on the Signal Receiving Sound.

● (This is for Servicing purposes only)

- Note: If you press this button continuously for 5 to 10 seconds, Test Run operation will be performed. A "beep" sound will be heard at the fifth seconds indicating the Test Run starts to operate.

■ Auto Restart Control

- If power is resumed after a power failure, the operation will restart automatically after 3 - 5 1/2 minutes.
- Operation will be restarted automatically under the previous operation mode and airflow direction when power is resumed as the operation is not stopped by the remote control.

■ Timer Setting

- When power failure occurs, the timer setting will be cancelled. Once power is resumed, reset the timer.

■ Thunder and Lightning

- This air conditioner is equipped with a built-in surge protective device. However, in order to further protect your air conditioner from being damaged by abnormally strong lightning activity, you may switch off the knife switch.

ENERGY SAVING AND OPERATION HINTS

■ Setting the Temperature

- Approximately 10% of electricity can be saved.
- Set the temperature 1°C higher than the desired temperature.

■ Air Filters and Air Purifying Filters

- Clean the air filters every 2 weeks and the Air Purifying Filters every 6 months.
- Dirty filters may reduce cooling efficiency.

■ Keep All Doors and Windows Closed

- Otherwise, cooling performance will be reduced and electricity cost is wasted.

■ Outdoor Unit

- Do not block the air outlet vents. Otherwise, it will lower the cooling performance.

■ Timer and Sleep Mode

- To prevent wastage of electricity, use sleep mode when sleeping or Timer when going out.

■ Avoid Direct Sunlight

- Keep curtains or drapes closed to avoid direct sunlight during cooling operation.

TROUBLESHOOTING

■ Normal Operation

Is it okay?	This is the answer
<ul style="list-style-type: none"> • Air conditioner has been restarted, but does not operate for 3 minutes. 	<ul style="list-style-type: none"> • This is to protect the air conditioner. Wait until the air conditioner begins to operate.
<ul style="list-style-type: none"> • A sound like water flowing can be heard. 	<ul style="list-style-type: none"> • This is the sound of refrigerant flowing inside the air conditioner.
<ul style="list-style-type: none"> • It seems that fog is coming out from the air conditioner. 	<ul style="list-style-type: none"> • Condensation occurs when the airflow from the air conditioner cools the room.
<ul style="list-style-type: none"> • The room has a peculiar odour. 	<ul style="list-style-type: none"> • This may be a damp smell emitted by the wall, carpet, furniture or clothing in the room.
<ul style="list-style-type: none"> • During Automatic Airflow setting, indoor fan stops occasionally. 	<ul style="list-style-type: none"> • This is to remove smell emitted by the surroundings.
<ul style="list-style-type: none"> • The outdoor unit emits water or steam. 	<ul style="list-style-type: none"> • In COOL/DRY operation, moisture in the air condenses into water on the cool surface of outdoor unit piping that causes dripping.

■ Abnormal Operation

Is it okay?	Please check
<ul style="list-style-type: none"> • The air conditioner does not operate. 	<ul style="list-style-type: none"> • Has the circuit breaker been tripped? • Is the timer being used correctly?
<ul style="list-style-type: none"> • Air conditioner produces loud noise during operation. 	<ul style="list-style-type: none"> • Is the installation work slanted? • Is the front grille closed properly?
<ul style="list-style-type: none"> • The air conditioner does not cool effectively. 	<ul style="list-style-type: none"> • Has the temperature been set incorrectly? • Are the filters dirty? • Are the intake or outlet vents of the outdoor unit obstructed? • Are all windows and doors closed?

■ Call the Dealer Immediately

If the following conditions occur, turn off the main power supply, and then call the dealer immediately.

- **Abnormal noise is heard during operation.**
- **Water or foreign material gets into the remote control by mistake.**
- **Water leak from the indoor unit.**
- **Switches or buttons do not operate properly.**
- **The circuit breaker switches off frequently.**
- **Power supply cord become unusually warm.**





10 Installation Instructions

Required tools for Installation Works			
1. Philips screw driver	5. Spanner	9. Gas leak detector	13. Multimeter
2. Level gauge	6. Pipe cutter	10. Measuring tape	14. Torque wrench 18 N.m (1.8 kgf.m) 42 N.m (4.2 kgf.m) 55 N.m (5.5 kgf.m)
3. Electric drill, hole core drill (ø70 mm)	7. Reamer	11. Thermometer	15. Vacuum pump
4. Hexagonal wrench (4 mm)	8. Knife	12. Megameter	16. Gauge manifold

10.1. Safety Precautions

- Read the following “SAFETY PRECAUTIONS” carefully before installation.
- Electrical work must be installed by a licensed electrician. Be sure to use the correct rating of the power plug and main circuit for the model to be installed.
- The caution items stated here must be followed because these important contents are related to safety. The meaning of each indication used is as below. Incorrect installation due to ignoring of the instruction will cause harm or damage, and the seriousness is classified by the following indications.



 WARNING	This indication shows the possibility of causing death or serious injury.
--------------------------------------------------------------------------------------------------	---------------------------------------------------------------------------

 CAUTION	This indication shows the possibility of causing injury or damage to properties only.
--------------------------------------------------------------------------------------------------	---------------------------------------------------------------------------------------

The items to be followed are classified by the symbols:

	Symbol with background white denotes item that is PROHIBITED from doing.
-------------------------------------------------------------------------------------	--------------------------------------------------------------------------

- Carry out test running to confirm that no abnormality occurs after the installation. Then, explain to user the operation, care and maintenance as stated in instructions. Please remind the customer to keep the operating instructions for future reference.

 WARNING	
1. Engage dealer or specialist for installation. If installation done by the user is defective, it will cause water leakage, electrical shock or fire.	
2. Install according to this installation instruction strictly. If installation is defective, it will cause water leakage, electrical shock or fire.	
3. Use the attached accessories parts and specified parts for installation. Otherwise, it will cause the set to fall, water leakage, fire or electrical shock.	
4. Install at a strong and firm location which is able to withstand the set's weight. If the strength is not enough or installation is not properly done, the set will drop and cause injury.	
5. For electrical work, follow the local national wiring standard, regulation and this installation instruction. An independent circuit and single outlet must be used. If electrical circuit capacity is not enough or defect found in electrical work, it will cause electrical shock or fire.	
6. Use the specified cable (1.5 mm ²) and connect tightly for indoor/outdoor connection. Connect tightly and clamp the cable so that no external force will be acted on the terminal. If connection or fixing is not perfect, it will cause heat-up or fire at the connection.	
7. Wire routing must be properly arranged so that control board cover is fixed properly. If control board cover is not fixed perfectly, it will cause heat-up at connection point of terminal, fire or electrical shock.	
8. When carrying out piping connection, take care not to let air substances other than the specified refrigerant go into refrigeration cycle. Otherwise, it will cause lower capacity, abnormal high pressure in the refrigeration cycle, explosion and injury.	
9. Do not damage or use unspecified power supply cord. Otherwise, it will cause fire or electrical shock.	
10. Do not modify the length of the power supply cord or use of the extension cord, and do not share the single outlet with other electrical appliances. Otherwise, it will cause fire or electrical shock.	







 **CAUTION**

- 1. This equipment must be earthed. It may cause electrical shock if grounding is not perfect.
- 2. Do not install the unit at place where leakage of flammable gas may occur. In case gas leaks and accumulates at surrounding of the unit, it may cause fire. 
- 3. Carry out drainage piping as mentioned in installation instructions. If drainage is not perfect, water may enter the room and damage the furniture.

ATTENTION

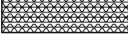
- 1. Selection of the installation location.
Select a installation location which is rigid and strong enough to support or hold the unit, and select a location for easy maintenance.
- 2. Power supply connection to the room air conditioner.
Connect the power supply cord of the room air conditioner to the mains using one of the following method.
Power supply point shall be the place where there is ease for access for the power disconnection in case of emergency.
In some countries, permanent connection of this room air conditioner to the power supply is prohibited.
 - 1. Power supply connection to the receptacle using a power plug.
Use an approved 15A/16A power plug with earth pin for the connection to the socket.
 - 2. Power supply connection to a circuit breaker for the permanent connection. Use an approved 16A circuit breaker for the permanent connection. It must be a double pole switch with a minimum 3 mm contact gap.
- 3. Do not release refrigerant.
Do not release refrigerant during piping work for installation, reinstallation and during repairing a refrigeration parts. Take care of the liquid refrigerant, it may cause frostbite.
- 4. Installation work.
It may need two people to carry out the installation work.
- 5. Do not install this appliance in a laundry room or other location where water may drip from the ceiling, etc.

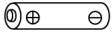
Attached accessories

No.	Accessories part	Qty.	No.	Accessories part	Qty.
1	Installation plate 	1	5	Air purifying filter 	1
2	Installation plate fixing screw 	6	6	Solar refreshing deodorizing filter 	1
3	Remote control 	1	7	Remote Control holder 	1
4	Battery 	2	8	Remote Control holder fixing screw 	2

Model	Piping size		Common Length (m)	Max. Elevation (m)	Max. Piping Length (m)	Additional Refrigerant (g/m)
	Gas	Liquid				
CS-C9BKPG x2 CU-2C14BKPG5G	3/8"	1/4"	7.5	5	15	10
CS-C9BKPG x2 CU-2C18BKPG5G	3/8"	1/4"	7.5	5	15	10
CS-C7BKPG x1 CU-2C19BKPG5G	3/8"	1/4"	7.5	5	15	10
CS-C12BKPG x1 CU-2C19BKPG5G	1/2"	1/4"	7.5	5	15	10
CS-C9BKPG x3 CU-3C20BKPG5G	3/8"	1/4"	7.5	5	15	10
CS-C9BKPG x1 CU-2C23BKPG5G	3/8"	1/4"	7.5	5	15	10
CS-C14BKPG x1 CU-2C23BKPG5G	1/2"	1/4"	7.5	5	15	10
CS-C12BKPG x2 CU-2C18BKPG5G	1/2"	1/4"	7.5	5	15	10

• The above models will be installed at a 15 m (max) distance.
The refrigerant should be added 75 a. (15-7.5) x 10 a = 75 a

Applicable piping kit

CZ-3F5, 7AEN (CS-C7BKPG, CS-C9BKPG)

CZ-4F5, 7, 10AN (CS-C12BKPG, CS-C14BKPG)

SELECT THE BEST LOCATION

INDOOR UNIT

- There should not be any heat source or steam near the unit.
- There should not be any obstacles blocking the air circulation.
- A place where air circulation in the room is good.
- A place where drainage can be easily done.
- A place where noise prevention is taken into consideration.
- Do not install the unit near the door way.
- Ensure the spaces indicated by arrows from the wall, ceiling, fence or other obstacles.
- Recommended installation height for indoor unit shall be at least 2.3 m.

OUTDOOR UNIT

- If an awning is built over the unit to prevent direct sunlight or rain, be careful that heat radiation from the condenser is not obstructed.
- There should not be any animal or plant which could be affected by hot air discharged.
- Keep the spaces indicated by arrows from wall, ceiling, fence or other obstacles.
- Do not place any obstacles which may cause a short circuit of the discharged air.
- If piping length is over the common length, additional refrigerant should be added as shown in the table.

Indoor/Outdoor Unit Installation Diagram

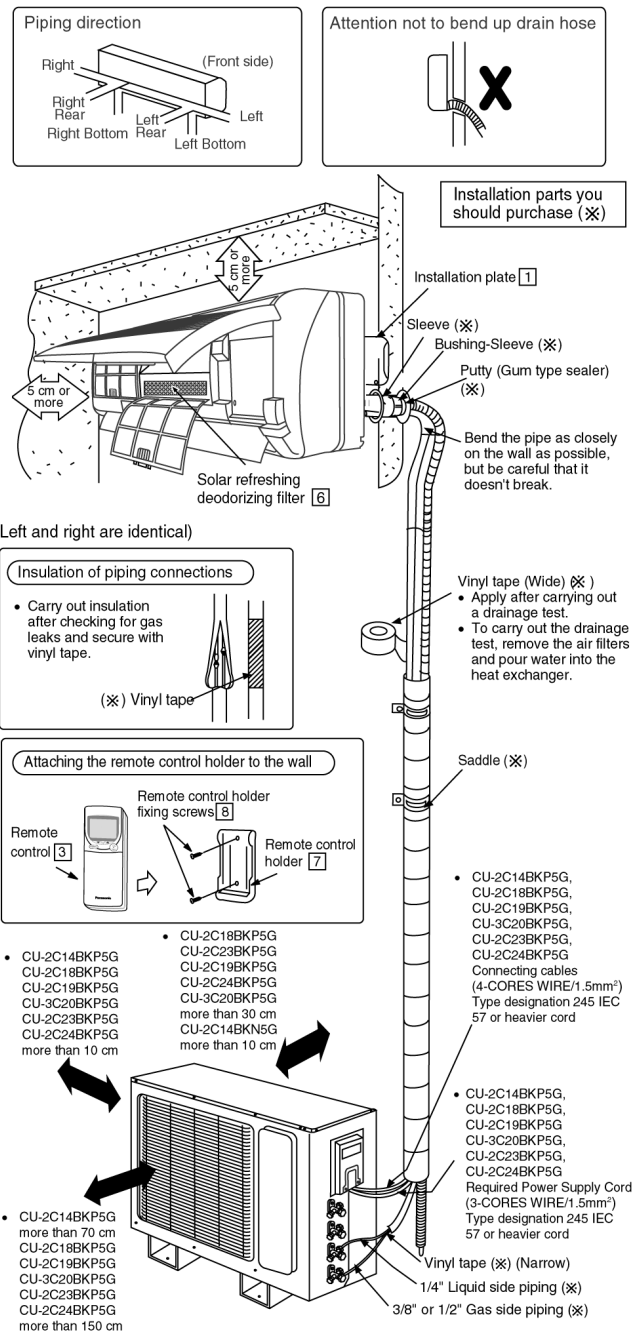

• This illustration is for explanation purpose only.
The indoor unit will actually face a different way.

10.2. INDOOR UNIT

10.2.1. SELECT THE BEST LOCATION (Refer to “Select the best location” section)

10.2.2. HOW TO FIX INSTALLATION PLATE

The mounting wall is strong and solid enough to prevent it from the vibration.

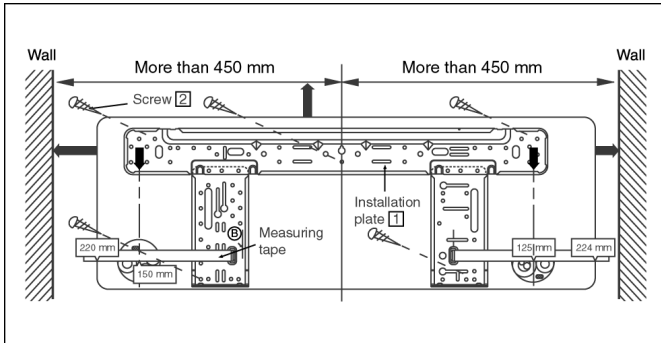

The centre of installation plate should be at more than 450 mm at right and left of the wall.

The distance from installation plate edge to ceiling should more than 67 mm.

From installation plate left edge to unit's left side is 47 mm.

From installation plate right edge to unit's right is 73 mm.

- Ⓑ : For left side piping, piping connection for liquid should be about 14 mm from this line.
- : For left side piping, piping connection for gas should be about 56 mm from this line.
- : For left side piping, piping connecting cable should be about 785 mm from this line.

1. Mount the installation plate on the wall with 5 screws or more.

(If mounting the unit on the concrete wall consider using anchor bolts.)

- Always mount the installation plate horizontally by aligning the marking-off line with the thread and using a level gauge.

2. Drill the piping plate hole with $\phi 70$ mm hole-core drill.

- Line according to the arrows marked on the lower left and right side of the installation plate. The meeting point of the extended line is the centre of the hole. Another method is by putting measuring tape at position as shown in the diagram above. The hole centre is obtained by measuring the distance namely 150 mm and 125 mm for left and right hole respectively.
- Drill the piping hole at either the right or the left and the hole should be slightly slanted to the outdoor side.

10.2.3. TO DRILL A HOLE IN THE WALL AND INSTALL A SLEEVE OF PIPING

1. Insert the piping sleeve to the hole.
2. Fix the bushing to the sleeve.
3. Cut the sleeve until it extrudes about 15 mm from the wall.

Caution

When the wall is hollow, please be sure to use the sleeve for tube ass'y to prevent dangers caused by mice biting the connecting cable.

4. Finish by sealing the sleeve with putty or caulking compound at the final stage.

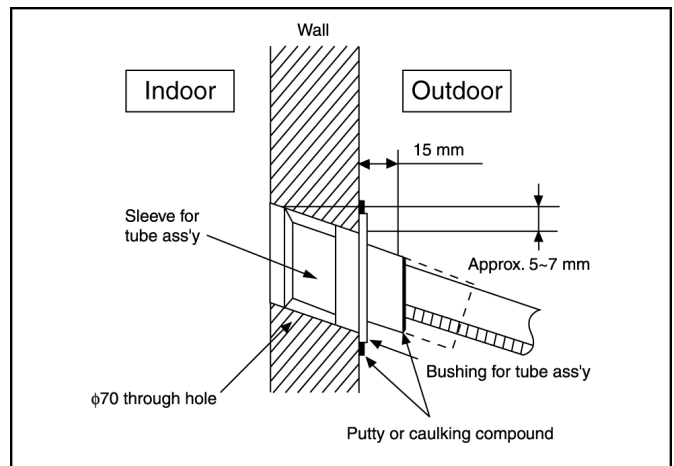

10.2.4. INDOOR UNIT INSTALLATION

1. For the right rear piping

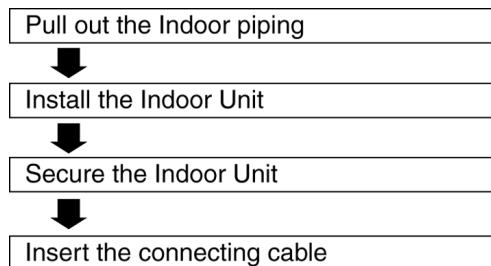

2. For the right and right bottom piping

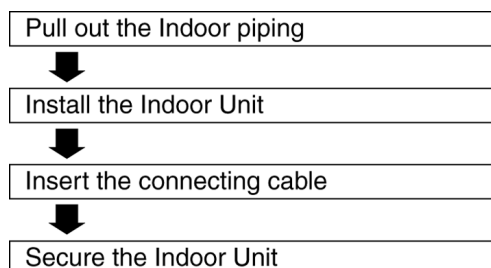

3. For the embedded piping

- Replace the drain hose
- ↓
- Bend the embedded piping
 - Use a spring bender or equivalent to bend the piping so that the piping is not crushed.
- ↓
- Install the Indoor Unit
- ↓
- Cut and flare the embedded piping
 - When determining the dimension of the piping, slide the unit all the way to the left on the installation plate.
 - Refer to the section "Cutting and flaring the piping".
- ↓
- Pull the connecting cable into Indoor Unit
 - The inside and outside connecting cable can be connected without removing the front grille.
- ↓
- Connect the piping
 - Please refer to "Connecting the piping" column in outdoor unit section. (Below steps are done after connecting the outdoor piping and gas-leakage confirmation.)
- ↓
- Insulate and finish the piping
 - Please refer to "Piping and finishing" column of outdoor section and "Insulation of piping connections" column as mentioned in Indoor/Outdoor Unit Installation.
- ↓
- Secure the Indoor Unit

Install the Indoor Unit

Hook the indoor unit onto the upper portion of installation plate (Engage the indoor unit with the upper edge of the installation plate). Ensure the hooks are properly seated on the installation plate by moving in left and right.

Secure the Indoor Unit

1. Tape the extra power supply cord in a bundle and keep it behind the chassis.
 - Ensure that the power supply cord is not clamped in between the unit's hook (2 positions) and installation plate.
2. Press the lower left and right side of the unit against the installation plate until hooks engages with their slots (sound click).

Pull out the piping and drain hose

Move the drain hose near to arrow mark and tape it with piping in a position as mentioned in Fig. below

To take out the unit, push the [PUSH] marking at the bottom unit, and pull it slightly towards you to disengage the hooks from the unit.

(This can be used for left rear piping & left bottom piping also.)

How to keep the cover

In case of the cover is cut, keep the cover at the rear of chassis as shown in the illustration for future reinstallation.

(Left, right and 2 bottom covers for piping)

Exchange the drain hose and the cap

Refer view for left piping installation

Adjust the piping slightly downwards

Insert the connecting cable

Length of connecting cable	77 cm
Cable	Gas side piping
	Liquid side piping

- How to pull the piping and drain hose out, in case of the embedded piping.

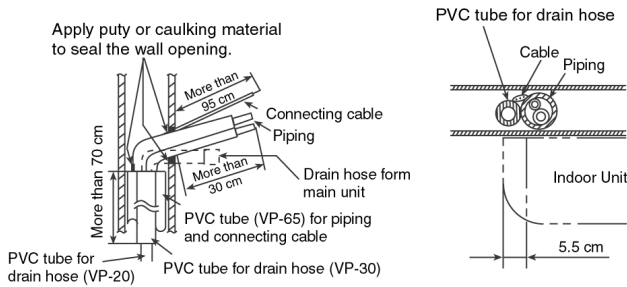

- In case of left piping how to insert the connecting cable and drain hose.

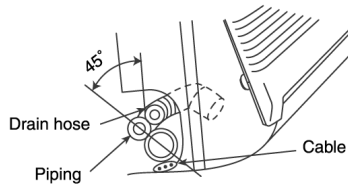

(For the right piping, follow the same procedure)

10.2.5. CONNECT THE CABLE TO THE INDOOR UNIT

1. The inside and outside connecting cable can be connected without removing the front grille.
2. Connecting cable between indoor unit and outdoor unit shall be approved polychloroprene sheathed $4 \times 1.5 \text{ mm}^2$ flexible cord, type designation 245 IEC 57 or heavier cord.
 - Ensure the color of wires of outdoor unit and the terminal Nos. are the same to the indoor's respectively.
 - Earth lead wire shall be longer than the other lead wires as shown in the figure for the electrical safety in case of the slipping out of the cord from the anchorage.

Terminals on the indoor unit	1	2	3	
Color of wires				
Terminals on the outdoor unit	1	2	3	

- Secure the cable onto the control board with the holder (clammer).

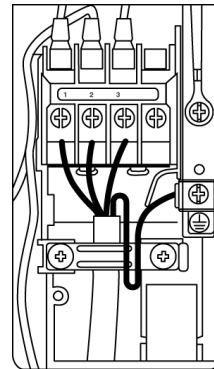

INSTALLATION OF AIR PURIFYING FILTERS

1. Open the front panel.
2. Remove the air filters.
3. Put air purifying filters (left) and solar refreshing deodorizing filter (right) into place as shown in illustration below.

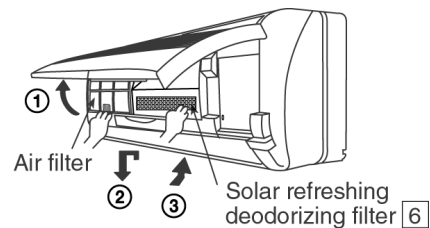

HOW TO TAKE OUT FRONT GRILLE

Please follow the steps below to take out front grille if necessary such as when servicing.

1. Set the vertical airflow direction louver to the horizontal position.
2. Slide down the two caps on the front grille as shown in the illustration below, and then remove the two mounting screws.
3. Pull the lower section of the front grille towards you to remove the front grille.

When reinstalling the front grille, first set the vertical airflow direction louver to the horizontal position and then carry out above steps 2 - 3 in the reverse order.

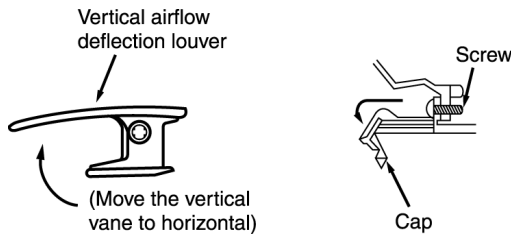

AUTO SWITCH OPERATION

The below operations will be performed by pressing the "AUTO" switch.

1. AUTO OPERATION MODE

The Auto operation will be activated immediately once the Auto Switch is pressed.

2. TEST RUN OPERATION (FOR PUMP DOWN/SERVICING PURPOSE)

The Test Run operation will be activated if the Auto Switch is pressed continuously for more than 5 sec. to below 10 sec.. A "pep" sound will occur at the fifth sec., in order to identify the starting of Test Run operation

3. REMOTE CONTROLLER RECEIVING SOUND ON/OFF

The ON/OFF of Remote Controller receiving sound can be change over by pressing the "AUTO" Switch continuously for 10 sec. and above. A "pep", "pep" sound will occur at the tenth sec., in order to indicate the "ON/OFF" change over of remote control receiving sound.

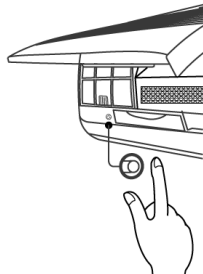

10.3. OUTDOOR UNIT

10.3.1. SELECT THE BEST LOCATION (Refer to "Select the best location" section)

10.3.2. INSTALL THE OUTDOOR UNIT

- After selecting the best location, start installation according to Indoor/Outdoor Unit Installation Diagram.

1. Fix the unit on concrete or rigid frame firmly and horizontally by bolt nut. (ø10 mm).
2. When installing at roof, please consider strong wind and earthquake. Please fasten the installation stand firmly with bolt or nails.

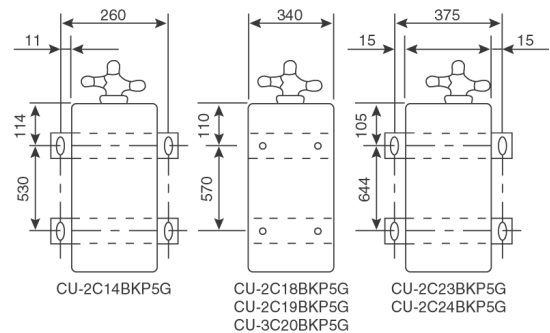

10.3.3. CONNECTING THE PIPING

Connecting the Piping to Indoor Unit

Please make flare after inserting flare nut (locate at joint portion of tube assembly) onto the copper pipe. (In case of using long piping)

Connect the piping

- Align the center of piping and sufficiently tighten the flare nut with fingers.
- Further tighten the flare nut with torque wrench in specified torque as stated in the table.

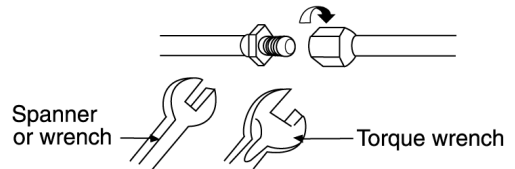

MODEL	Piping size (Torque)	
	Gas	Liquid
CS-C7BKPG	3/8" (42 N.m)	1/4" (18 N.m)
CS-C9BKPG	3/8" (42 N.m)	1/4" (18 N.m)
CS-C12BKPG	1/2" (55 N.m)	1/4" (18 N.m)
CS-C14BKPG	1/2" (55 N.m)	1/4" (18 N.m)

Connecting the Piping to Outdoor Unit

1. Align the center of the piping and sufficiently tighten the flare nut with fingers.
2. Finally, tighten the flare nut with torque wrench until the wrench clicks.
 - When tightening the flare nut with torque wrench, ensure the direction for tightening follows the arrow on the wrench.

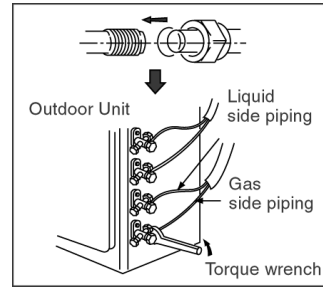

Caution

The CU-3C20BKPG5G/C9BKPG have different cooling capacities depending on the connection to A₁, A₂ and/or B on CU-3C20BKPG5G individually.

(Refer to SPECIFICATIONS on CATALOG)

1. The Cooling Capacity of Indoor Unit connecting "B" on CU-3C20BKPG5G (Called B unit) is different from that of A₁ and A₂ Units.
2. A₁ and A₂ Units share the same compressor, their cooling capacities thus change depending on whether one, the other, or both of the units is in use.
3. Reflect the B or A (A₁ and/or A₂) on the Indoor Unit for later reference.

CUTTING AND FLARING THE PIPING

1. Please cut using pipe cutter and then remove the burrs.
2. Remove the burrs by using reamer. If burrs is not removed, gas leakage may be caused.
Turn the piping end down to avoid the metal powder entering the pipe.
3. Please make flare after inserting the flare nut onto the copper pipes.

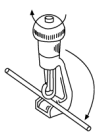

1. To cut

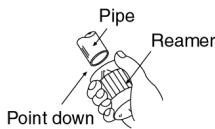

2. To remove burrs

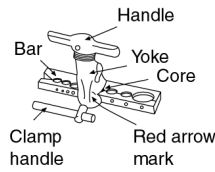

3. To flare

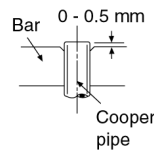

Improper flaring

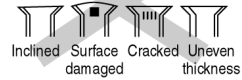

When properly flared, the internal surface of the flare will evenly shine and be of even thickness. Since the flare part comes into contact with the connections, carefully check the flare finish

10.3.4. EVACUATION OF THE EQUIPMENT

WHEN INSTALLING AN AIR CONDITIONER, BE SURE TO EVACUATE THE AIR INSIDE THE INDOOR UNIT AND PIPES in the following procedure.

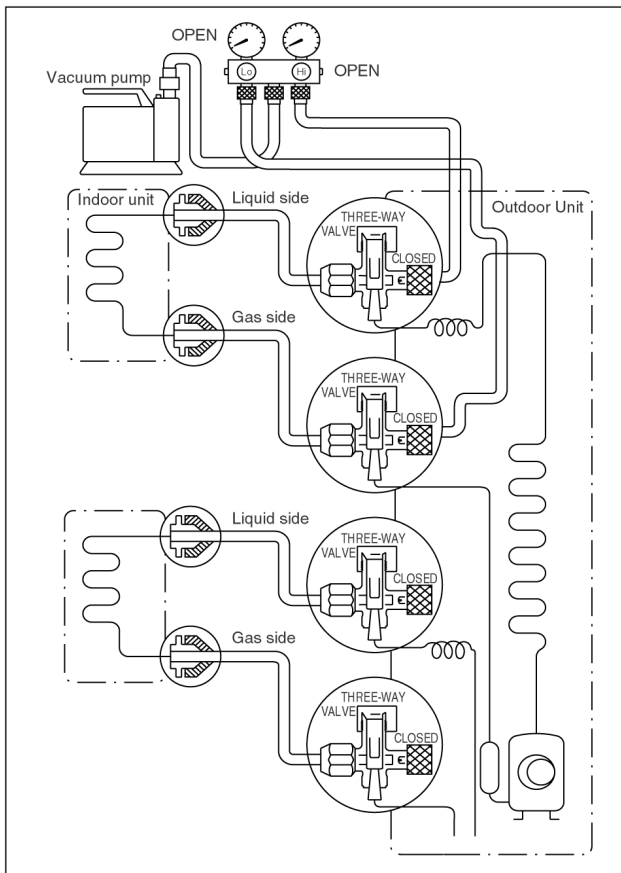

1. Connect a charging hose with a push pin to the Low and High side of a charging set and the service port of the 3-way valve.
 - Be sure to connect the end of the charging hose with the push pin to the service port.
2. Connect the center hose of the charging set to a vacuum pump with check valve, or vacuum pump and vacuum pump adaptor.
3. Turn on the power switch of the vacuum pump and make sure that the needle in the gauge moves from 0 cmHg (0 MPa) to -76 cmHg (-0.1 MPa). Then evacuate the air approximately ten minutes.
4. Close the Low side valve of the charging set and turn off the vacuum pump. Make sure that the needle in the gauge does not move after approximately five minutes.

Note: BE SURE TO FOLLOW THIS PROCEDURE IN ORDER TO AVOID REFRIGERANT GAS LEAKAGE.
5. Disconnect the charging hose from the vacuum pump and from the service port of the 3-way valve.
6. Tighten the service port caps of the 3-way valve at torque of 18 N.m with a torque wrench.
7. Remove the valve caps of both of the 2-way valve and 3-way valve. Position both of the valves to "OPEN" using a hexagonal wrench (4 mm).
8. Mount valve caps onto the 2-way valve and the 3-way valve.
 - Be sure to check for gas leakage.

CAUTION

- If gauge needle does not move from 0 cmHg (0 MPa) to -76 cmHg (-0.1 MPa), in step 3 above take the following measure:
- If the leak stops when the piping connections are tightened further, continue working from step 3.
- If the leak does not stop when the connections are retightened, repair the location of leak.
- Do not release refrigerant during piping work for installation and reinstallation. Take care of the liquid refrigerant, it may cause frostbite.

10.3.5. CONNECT THE CABLE TO THE OUTDOOR UNIT

1. Remove the control board cover from the unit by loosening the screw.
2. Connecting cable between indoor unit and outdoor unit shall be approved polychloroprene sheathed flexible cord, type designation 245 IEC 57 or heavier cord (4 × 1.5 mm²).

Power supply cord cable use 3 × 1.5 mm² flexible cord, type designation 245 IEC 57 or heavier cord.

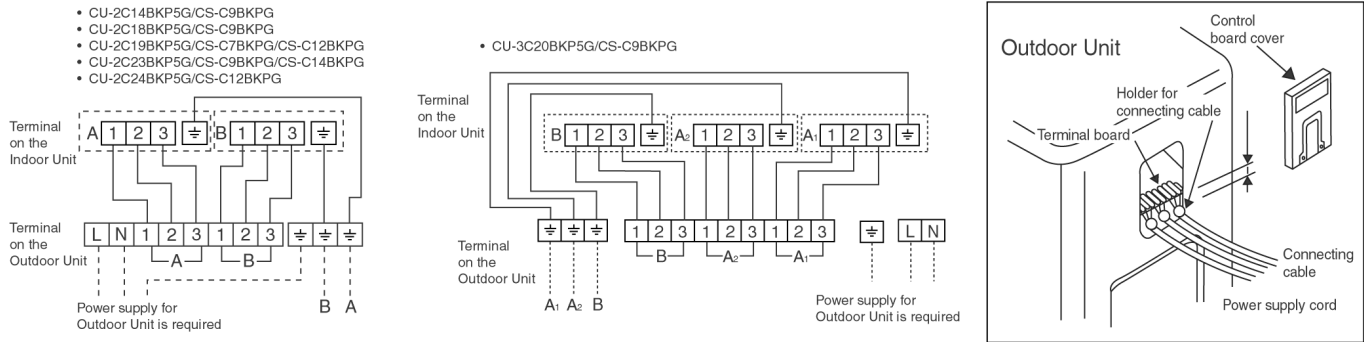

3. Secure the cable onto the control board with the holder (clamber).
4. Confirm the SW1 Switch at AUTO position. (CU-2C14BKP5G, CU-3C20BKP5G)
5. Attach the control board cover back to the original position with the screw.

10.3.6. PIPE INSULATION

1. Please carry out insulation at pipe connection portion as mentioned in Indoor/Outdoor Unit Installation Diagram. Please wrap the insulated piping end to prevent water from going inside the piping.
2. If drain hose or connecting piping is in the room (where dew may form), please increase the insulation by using POLY-E FOAM with thickness 6 mm or above.

CHECK THE DRAINAGE

- Open front panel and remove air filters. (Drainage checking can be carried out without removing the front grille.)
- Pour a glass of water into the drain tray-styrofoam.
- Ensure that water flows out from drain hose of the indoor unit.

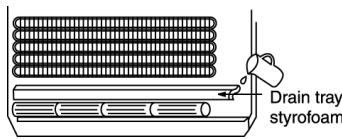

EVALUATION OF THE PERFORMANCE

- Operate the unit at cooling operation mode for fifteen minutes or more.
- Measure the temperature of the intake and discharge air.
- Ensure the difference between the intake temperature and the discharge is more than 8°C.

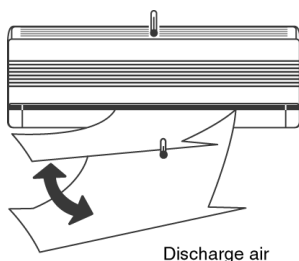

CHECK ITEMS

- Is there any gas leakage at flare nut connections?
- Has the heat insulation been carried out at flare nut connection?
- Is the connecting cable being fixed to terminal board firmly?
- Is the connecting cable being clamped firmly?
- Is the drainage OK?
(Refer to "Check the drainage" section)
- Is the earth wire connection properly done?
- Is the indoor unit properly hooked to the installation plate?
- Is the power supply voltage complied with rated value?
- Is there any abnormal sound?
- Is the cooling operation normal?
- Is the thermostat operation normal?
- Is the remote control's LCD operation normal?
- Is the air purifying filter installed?

11 3-way Valve

	3-way Valve (Liquid Side)		3-way Valve (Gas Side)	
Works	Shaft Position	Service Port	Shaft Position	Service Port
Shipping	Closed (With valve cap)	Closed (With cap)	Closed (With valve cap)	Close (With cap)
(Installation and Re-installation)	Closed (Clockwise)	Open (Connected manifold gauge w/charging cylinder)	Closed (Clockwise)	Open (Push-pin)
Operation	Open (With valve cap)	Closed (With cap)	Open (With valve cap)	Closed (With cap)
Pumping down (Transferring)	Closed (Clockwise)	Closed (With cap)	Open (Counter-clockwise)	Open (Connected manifold gauge)
Evacuation (Servicing)	Open (Counter-clockwise)	Open (Connected manifold gauge)	Open (Counter-clockwise)	Open (Connected manifold gauge)
Gas charging (Servicing)	Open (Counter-clockwise)	Open (Connected manifold gauge)	Open (Counter-clockwise)	Open (Connected manifold gauge)
Pressure check (Servicing)	Open (Counter-clockwise)	Closed (With cap)	Open (Counter-clockwise)	Open (Connected manifold gauge)
Gas releasing (Servicing)	Open (Counter-clockwise)	Open (Connected manifold gauge)	Open (Counter-clockwise)	Open (Connected manifold gauge)

11.1. Evacuation of the Equipment

11.1.1. Evacuation of the Installation

When installing an air conditioner, be sure to evacuate the air inside the indoor unit and pipes in the following procedure.

Required tools: Hexagonal wrench, adjustable wrench, torque wrenches, wrench to hold the joints, gas leak detector, and charging set.

The air in the indoor unit and in the piping must be purged. If air remains in the refrigeration pipings, it will affect the compressor, reduce the cooling capacity, and could lead to a malfunction.

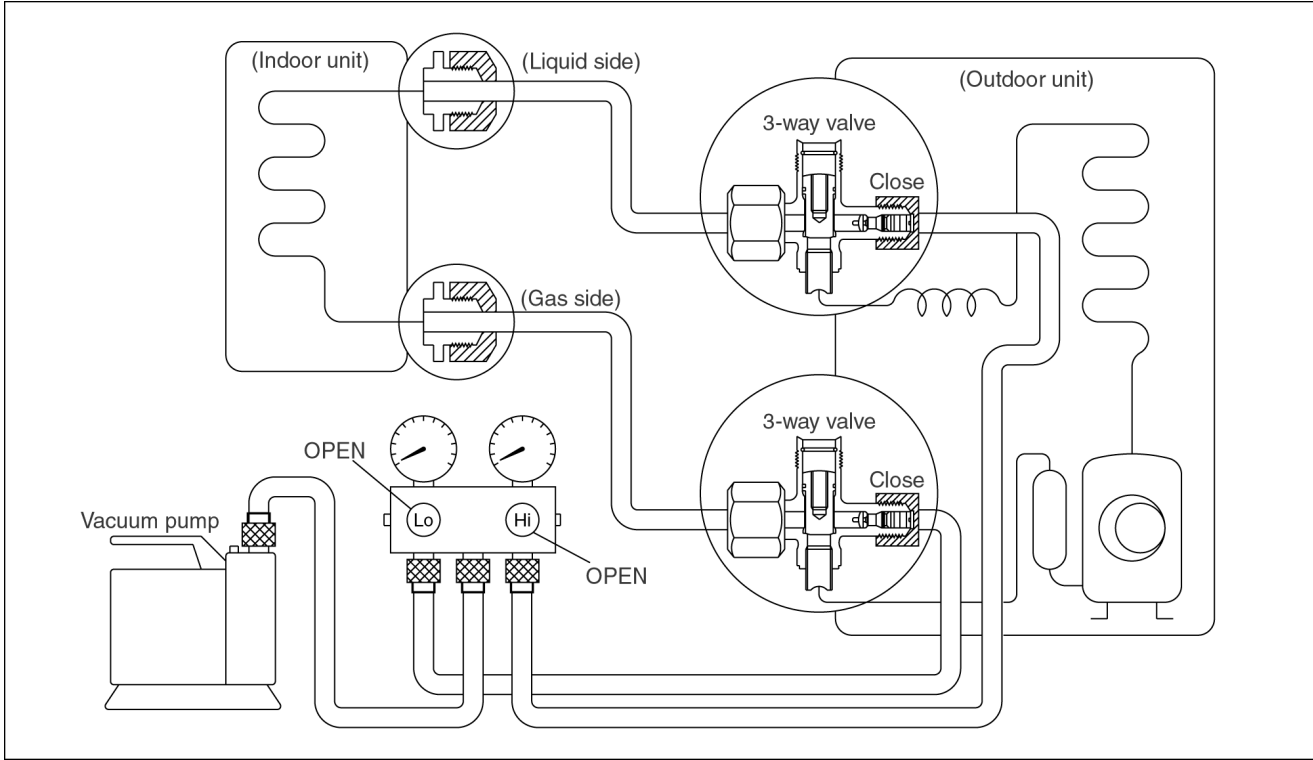

Service port cap

Be sure, using a torque wrench to tighten the service port nut (after using the service port), so that it prevents the gas leakage from the refrigeration cycle.

Procedure:

1. Connect a charging hose with a push pin to the Low and High sides of a charging set and the service ports of a 3-way valves.
 - Be sure to connect the end of the charging hose with the push pin to the service port.
2. Connect the centre hose of the charging set to a vacuum pump.
3. Turn on the power switch of the vacuum pump and make sure that the needle in the gauge moves from 0 cmHg (0 MPa) to -76 cmHg (-0.1 MPa). Then evacuate the air for approximately 10 minutes.
4. Close the valve of both the Low and High sides of the charging set and turn off the vacuum pump. Make sure that the needle in the gauge does not move after approximately 5 minutes.

BE SURE TO TAKE THIS PROCEDURE IN ORDER TO AVOID REFRIGERANT GAS LEAKAGE.
5. Disconnect the charging hose from the vacuum pump and from the service ports of the 3-way valves.
6. Tighten the service port caps of both the 3-way valves at a torque of 18 N.m with a torque wrench.
7. Remove the valve caps of both the 3-way valves. Position both of the valves to "open" using a hexagonal wrench (4 mm).
8. Mount the valve caps onto both of the 3-way valves.
 - Be sure to check for gas leakage.

Caution

If gauge needle does not move from 0 cmHg (0 MPa) to -76 cmHg (-0.1 MPa) in step (3) above, take the following measures:

If the leaks stop when the piping connections are tightened further, continue working from step (3).

If the leaks do not stop when the connections are retightened, repair the location of the leak.

11.1.2. Pumping down

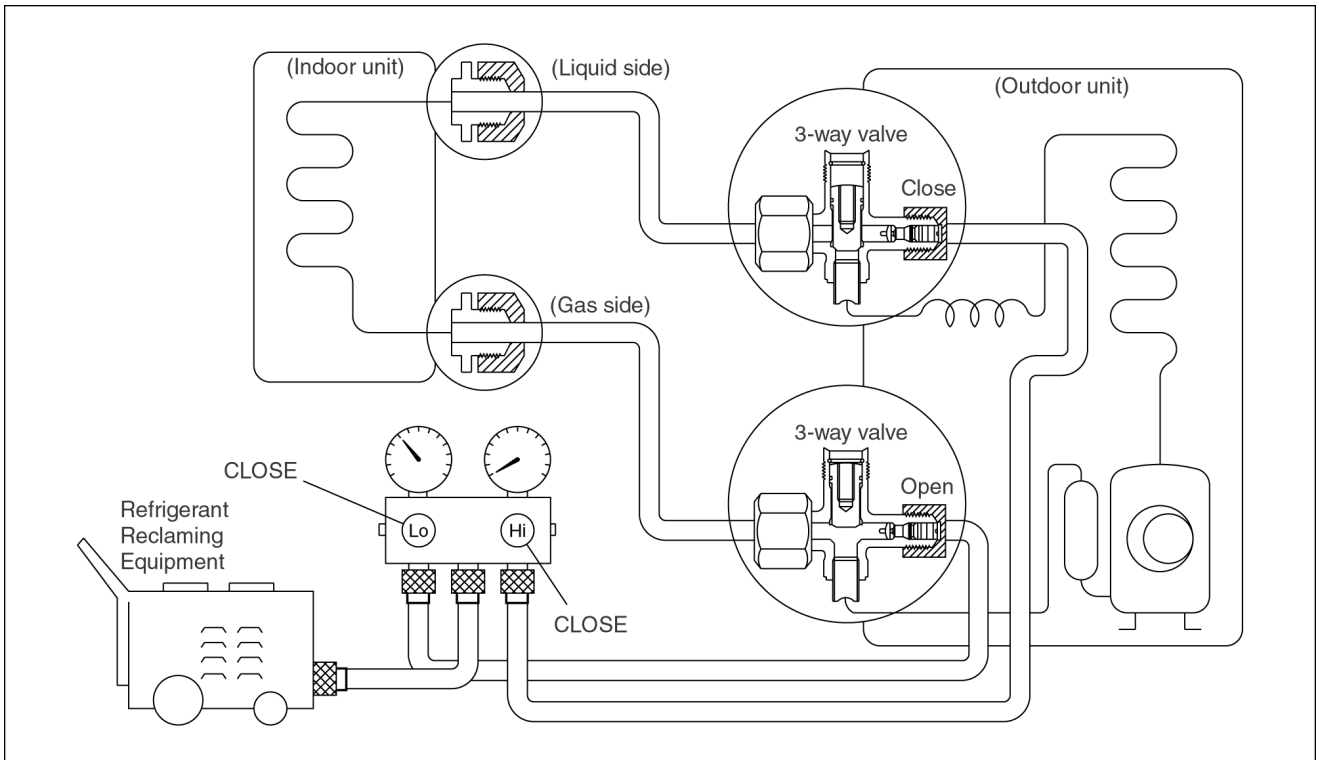

Procedure:

1. **Confirm that both the 3-way valves are set to the open position.**
 - Remove the valve stem caps and confirm that the valve stems are in the open position.
 - Be sure to use a hexagonal wrench to operate the valve stems.
2. **Operate the unit for 10 to 15 minutes.**
3. **Stop operation and wait for 3 minutes, then connect the charge set to the service port of the 3-way valve.**
 - Connect the charge hose with the push pin to the Gas side service port.
4. **Air purging of the charge hose.**
 - Open the low-pressure valve on the charge set slightly to purge air from the charge hose.
5. **Set the Liquid side 3-way valve to the close position.**
6. **Operate the air conditioner at the cooling cycle and stop it when the gauge indicates 0 kg/cm²G (0 MPa).**
 - If the unit cannot be operated at the cool condition (weather is rather cool), press the Pump Down Switch on the Indoor unit.
 - So that the unit can be operated.
7. **Immediately set the gas side 3-way valve to the close position.**
 - Do this quickly so that the gauge ends up indicating 1 to 3 kg/cm²G (0.1 MPa to 0.3 MPa)
8. **Use refrigerant reclaiming equipment to collect refrigerant from indoor unit and pipes.**
9. **Disconnect the charge set, and mount both the 3-way valve's stem nuts and the service port caps.**
 - Use a torque wrench to tighten the service port cap to a torque of 18 N.m.
 - Be sure to check for gas leakage.
10. **Disconnect pipes from indoor unit and outdoor unit.**

11.1.3. Evacuation of Re-installation

WHEN REINSTALLING AN AIR CONDITIONER, BE SURE TO EVACUATE THE AIR INSIDE THE INDOOR UNIT AND PIPES in the following procedure.

If air remains in the indoor unit and refrigeration pipes, it will affect the compressor, reduce to cooling capacity, and could lead to a malfunction.

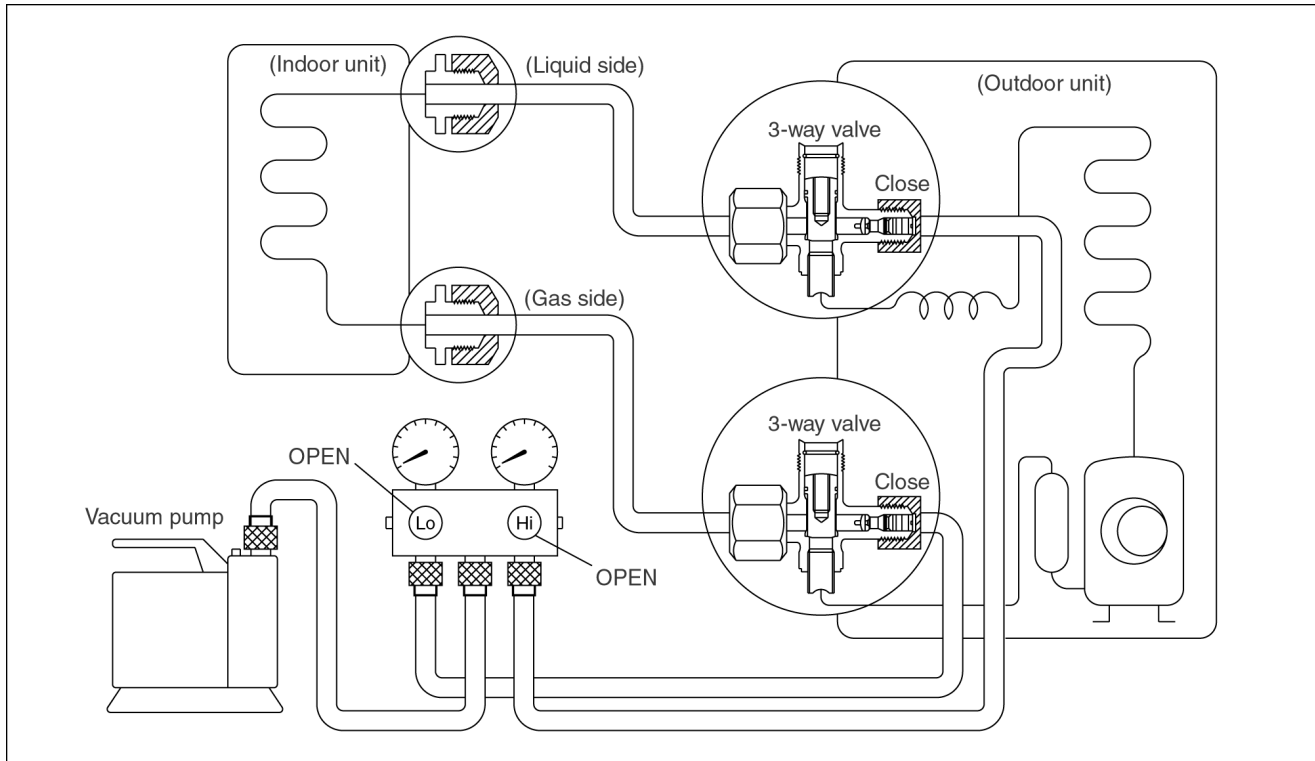

Procedure:

1. Connect a charging hose with a push pin to the Low and High sides of a charging set and the service port of the 3-way valve.
 - Be sure to connect the end of the charging hose with the push pin to the service port.
2. Connect the centre hose of the charging set to a vacuum pump.
3. Turn on the power switch of the vacuum pump and make sure that the needle in the gauge moves from 0 cmHg (0 MPa) to -76 cmHg (-0.1 MPa). Then evacuate the air for approximately 10 minutes.
4. Close the valve of both Low side and High side of the charging set and turn off the vacuum pump. Make sure that the needle in the gauge does not move after approximately 5 minutes.

BE SURE TO TAKE THIS PROCEDURE IN ORDER TO AVOID REFRIGERANT GAS LEAKAGE.
5. Disconnect the charging hose from the vacuum pump.
6. Charge the pipes and indoor unit with gas refrigerant from liquid (High) side 3-way valve service port and then discharge the refrigerant until gas side (Low) side gauge needle indicates 3 kg/cm² (0.3 MPa).

• BE SURE TO USE REFRIGERANT RECLAIMING EQUIPMENT WHILE DISCHARGING THE REFRIGERANT.

- Purge the air from charge set's centre hose.
- Be sure to check for gas leakage.

Caution

If gauge needle does not move from 0 cmHg (0 MPa) to -76 cmHg (-0.1 MPa) in step (3) above, take the following measures:

If the leaks stop when the piping connections are tightened further, continue working from step 3.

If the leaks do not stop when the connections are retightened, repair the location of the leak.

7. Tighten the service port caps of both the 3-way valves at a torque of 18 N.m with a torque wrench.
8. Remove the valve caps of both the 3-way valves. Position both of the valves to "open" using a hexagonal wrench (4 mm).
9. Mount valve caps onto the 3-way valves.

11.1.4. Balance refrigerant of the 3-way valves

(Lack of refrigerant in the refrigeration cycle)

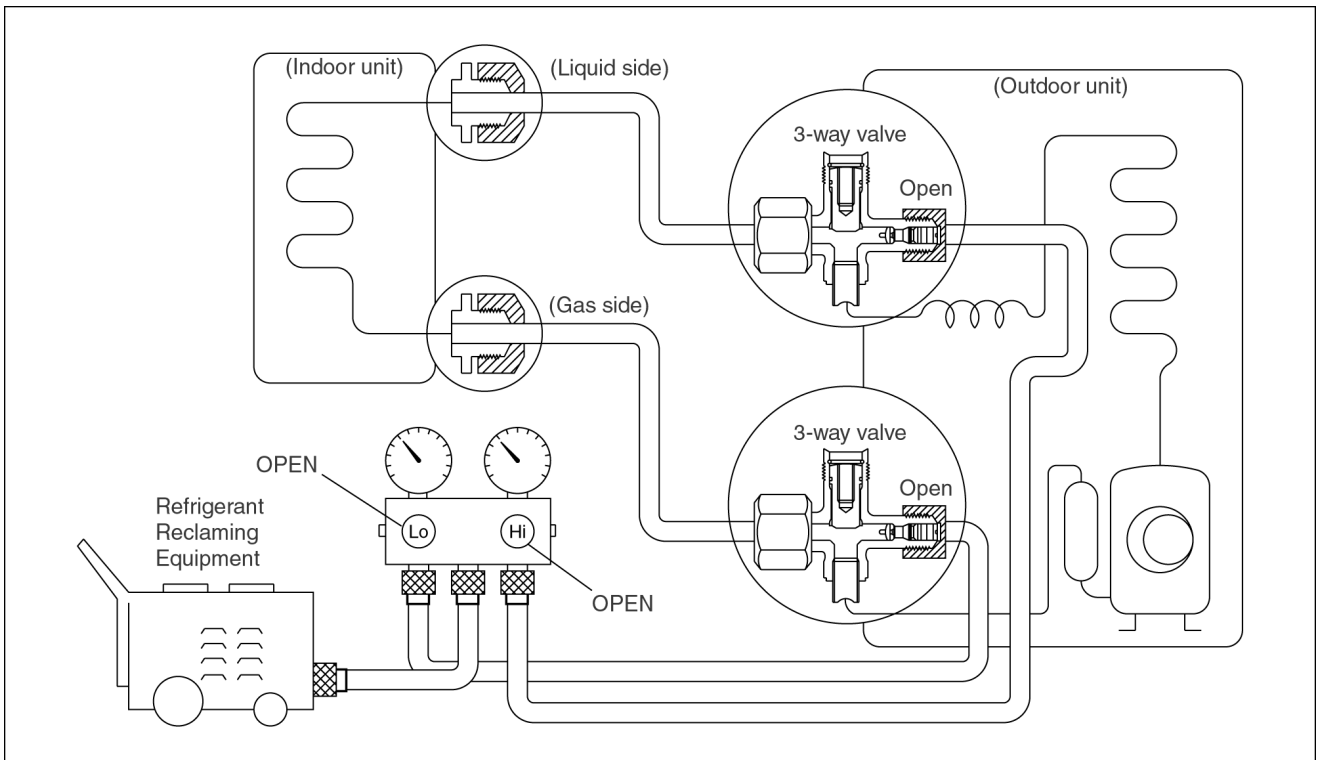

Procedure:

1. Confirm that both the 3-way valves are set to the opened position.
2. Connect the charge set to the 3-way valve's service port.
 - Leave the valve on the charge set closed.
 - Connect the charge hose with the push-pin to the service port.
 - Confirm whether the pressure indicates more than 0.1 MPa (1 kg/cm²G).
3. Connect the charge set's centre hose to refrigerant reclaiming equipment.
4. Open the valve (Low side) on the charge set and loosen the hose connected with the Refrigerant Reclaiming Equipment to purge the air from the hose.
5. Turn on refrigerant reclaiming equipment to collect the refrigerant until the needle indicates 0 (no refrigerant is remaining).

11.1.5. Evacuation

(No refrigerant in the refrigeration cycle)

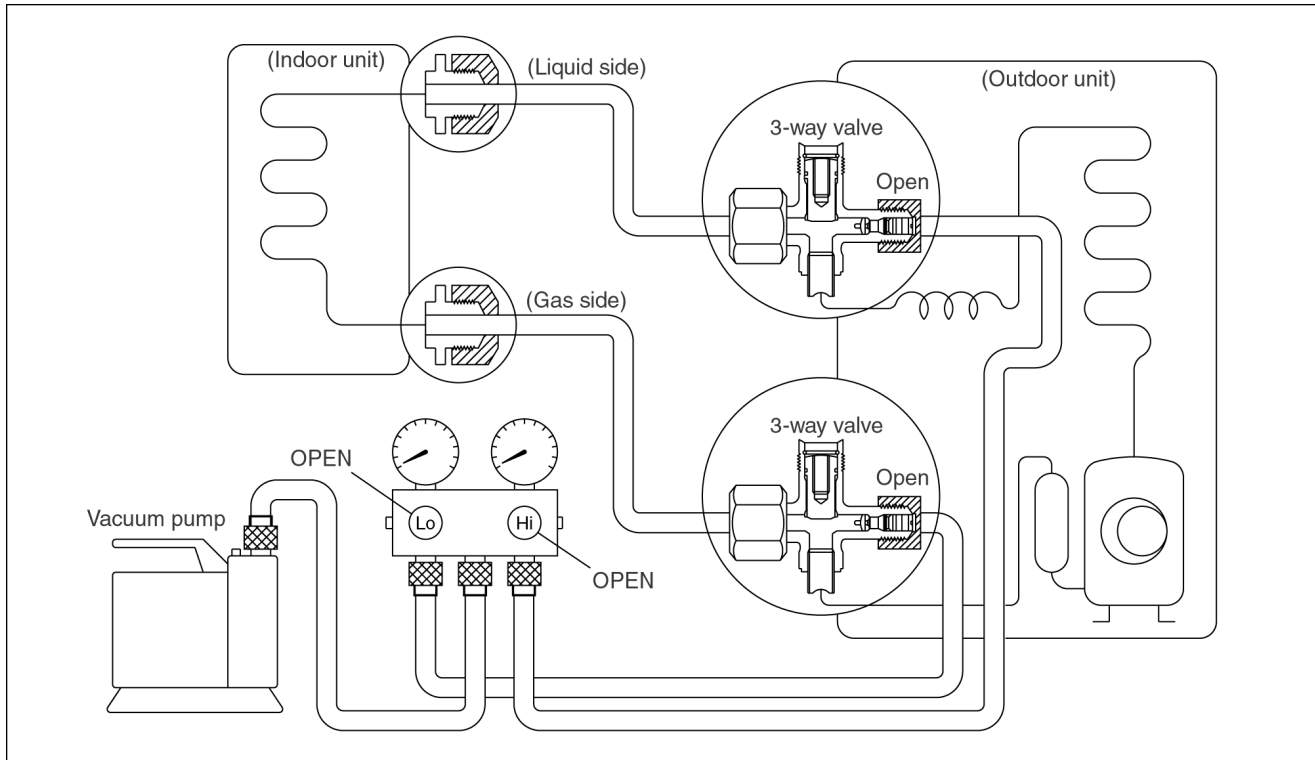

Procedure:

1. Connect the vacuum pump to the charge set's centre hose.
2. Turn on the vacuum pump to evacuate the unit.
 - Confirm that the gauge needle has moved toward -76 cmHg (-0.1 MPa).
 - Apply the vacuum for approximately 1 hour (vacuum of 4 mmHg or less).
3. Close the valves (Low side and High side) on the charge set, turn off the vacuum pump, and confirm that the gauge needle does not move (approximately 5 minutes after the vacuum pump is turned off).
4. Disconnect the charge hose from the vacuum pump.

11.1.6. Gas charging

(After Evacuation)

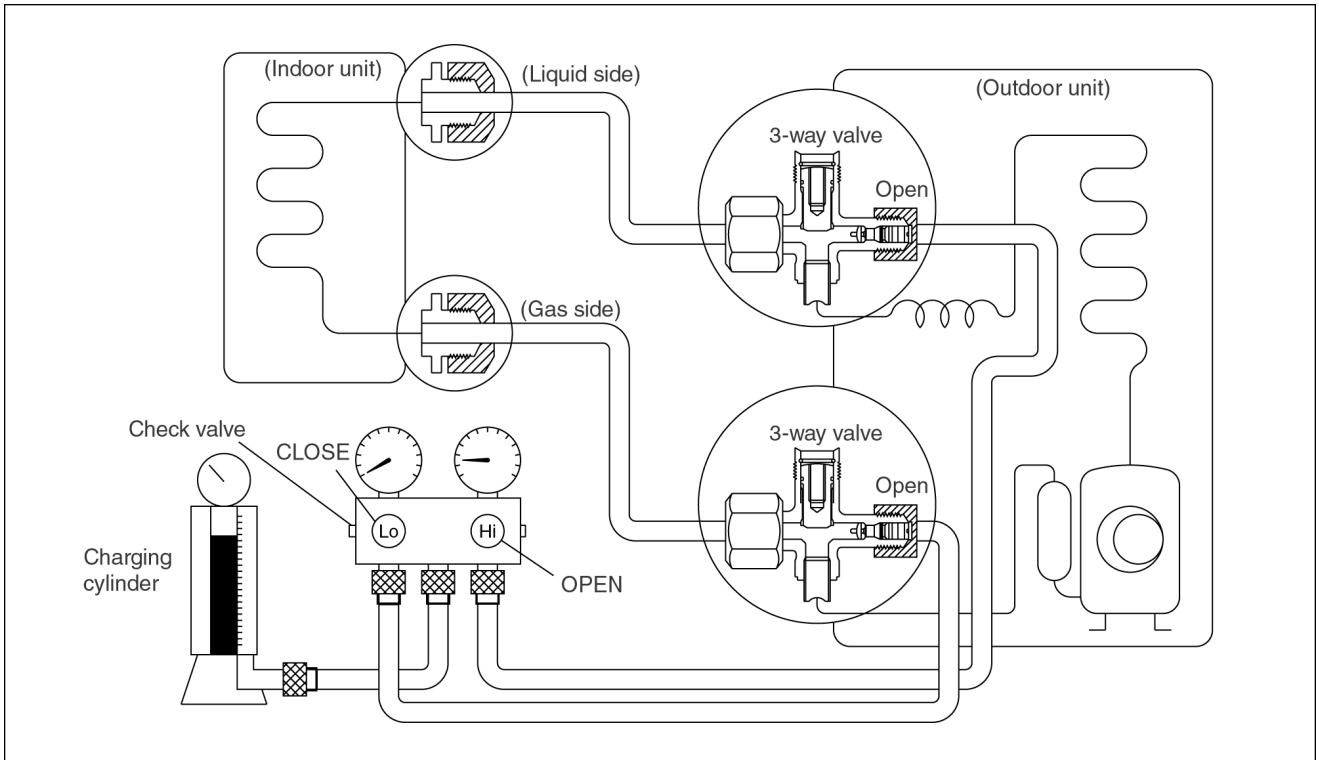

Procedure:

1. Connect the charge hose to the charging cylinder.

- Connect the charge hose which you disconnected from the vacuum pump to the valve at the bottom of the cylinder.

2. Purge the air from the charge hose.

- Open the valve at the bottom of the cylinder and use a screwdriver to press the check valve on the charge set to purge the air (be careful of the liquid refrigerant).

3. Open the High side on the charge set and charge the refrigerant to the unit.

- Be sure to open only the High side valve on the charge set to charge the system from the liquid-side (high-pressure) pipe. (If the system cannot be charged with the specified amount of refrigerant, operate the compressor until the specified amount can be charged, and then close the valve at the bottom of the charge cylinder.)

4. Immediately disconnect the charge hoses from both 3-way valve service ports.

5. Mount the valve stem nuts and the service port caps onto the 3-way valves.

- Use torque wrench to tighten the service port caps to a torque of 18 N.m.
- Be sure to check for gas leakage.

12 Servicing Information

12.1. Indoor Electronic Controllers Removal Procedures

1. The Electronic Controller, a Signal Receiver and an Indicator (Fig. 3) can be seen by the below steps:

- Remove the 2 caps and 2 screws at the bottom of the Front Grille. (Fig. 1)
- Remove the Front Grille by releasing the 2 hooks at the top of the Front Grille. (Fig. 1)

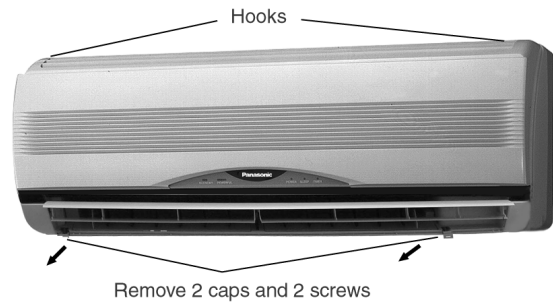

Fig. 1

- Remove the Control Board Cover by releasing the 2 tabs at left, 1 tab on top and 1 tab at right side of the Control Board Cover. (Fig. 2)

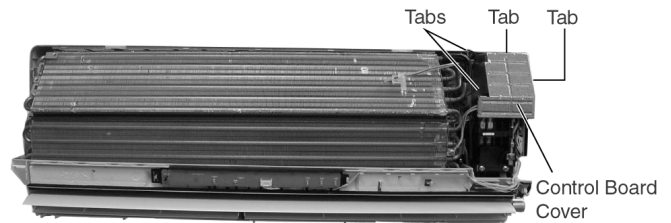

Fig. 2

2. To remove the Electronic Controller:

- Release the Particular Piece. (Fig. 3)
- Release the hook that hold the Electronic Controller. (Fig. 3)

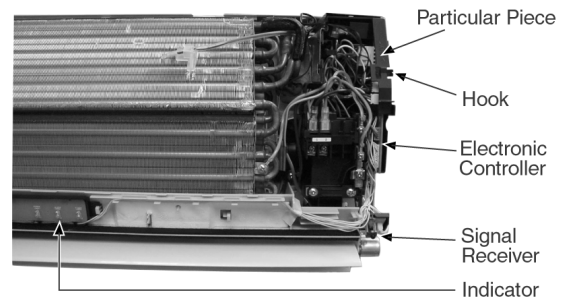

Fig. 3

12.2. Indoor Fan Motor and Cross Flow Fan Removal Procedures

- Remove the Control Board by:-

- Releasing CN-REC/DISP connectors. (Fig. 4)
- Releasing CN-FM connectors. (Fig. 4)
- Releasing CN-STM connector. (Fig. 4)
- Removing the Earth Wire screw. (Fig. 4)
- Releasing the Intake Air Sensor. (Fig. 4)
- Releasing the Piping Sensor. (Fig. 4)

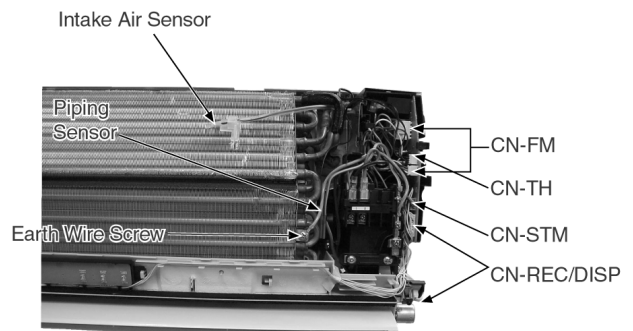

Fig. 4

- Pulling out the Drain Hose from outlet to remove the Discharge Grille. (Fig. 5)
- Removing the right and left screws. (Fig. 5)
- Then remove the Control Board by pressing down the hook at the left and pushing up the right hook. (Fig. 5)

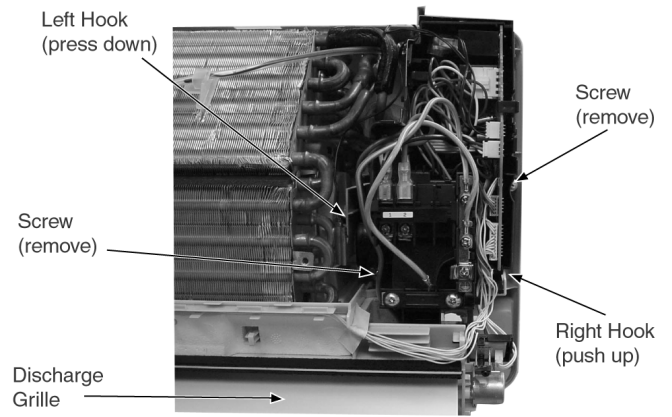

Fig. 5

- Release the Fan Motor leadwire by pressing the hook at the center of the connector. (Fig. 6)

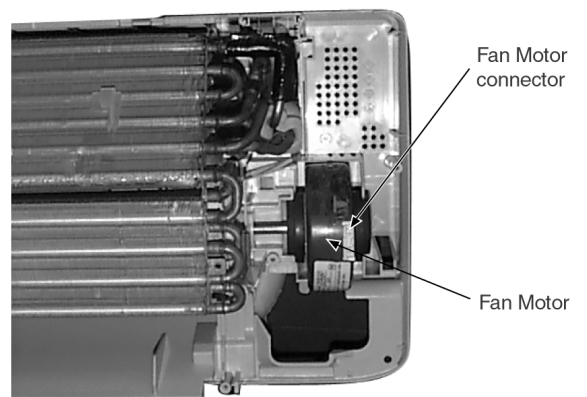

Fig. 6

- Remove the screw at the Cross Flow Fan. (Fig. 7)
- REMINDER - To reinstall the Fan Motor, adjust the connector of the Fan Motor as shown in the Fig. 7.

To reinstall the Fan Motor, please adjust the connector location is positioned 45° with Fan Motor before fixing Control Board Complete.

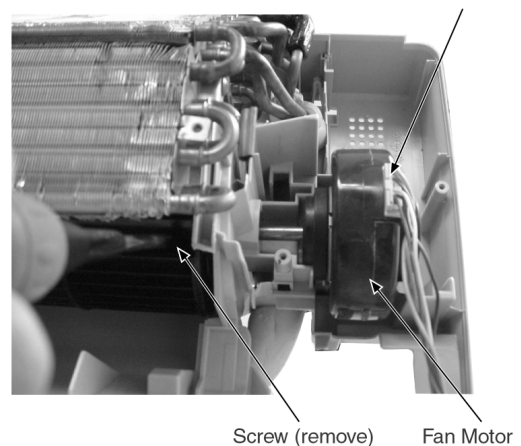

Fig. 7

- Remove the screws at the left of the Evaporator. (Fig. 8)

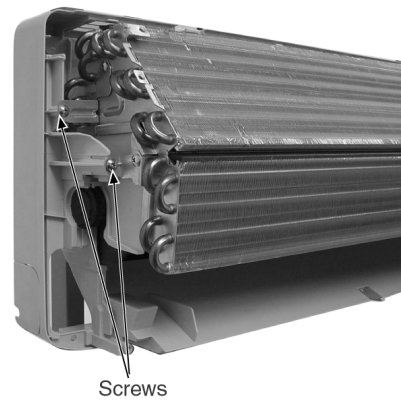

Fig. 8

- Remove the Bearing. (Fig. 9)
- Push up the Evaporator and pull out the Cross Flow Fan from shaft. By then, Fan Motor can be taken out. (Fig. 9)

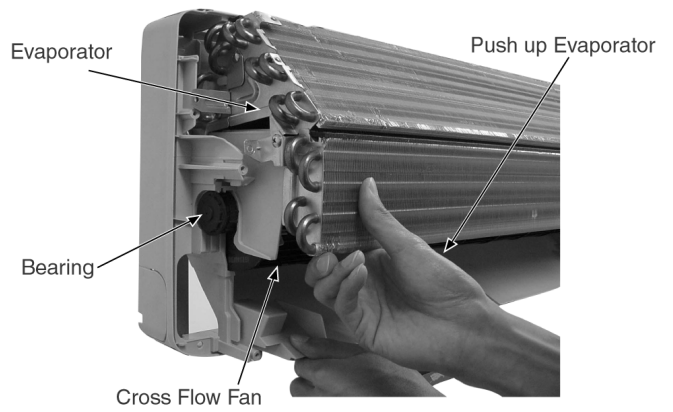

Fig. 9

• Remote Control Reset

When the batteries are inserted for the first time, or the batteries are replaced, all the indications will blink and the remote control might not work.

If this happen, remove the cover of the remote control and you will find a resetting terminal, and by shorting it with a minus screwdriver, it will return to normal.



• Changing the wireless remote control transmission code

When two indoor units are installed in the same room, in order to prevent operating errors caused by using two remote controls, cut a jumper wire at the remote control printed circuit board (J - A) and cut a jumper wire at the indoor printed circuit board (JX4). It is possible to select from 4 types of transmission codes including one at time of delivery condition (0).

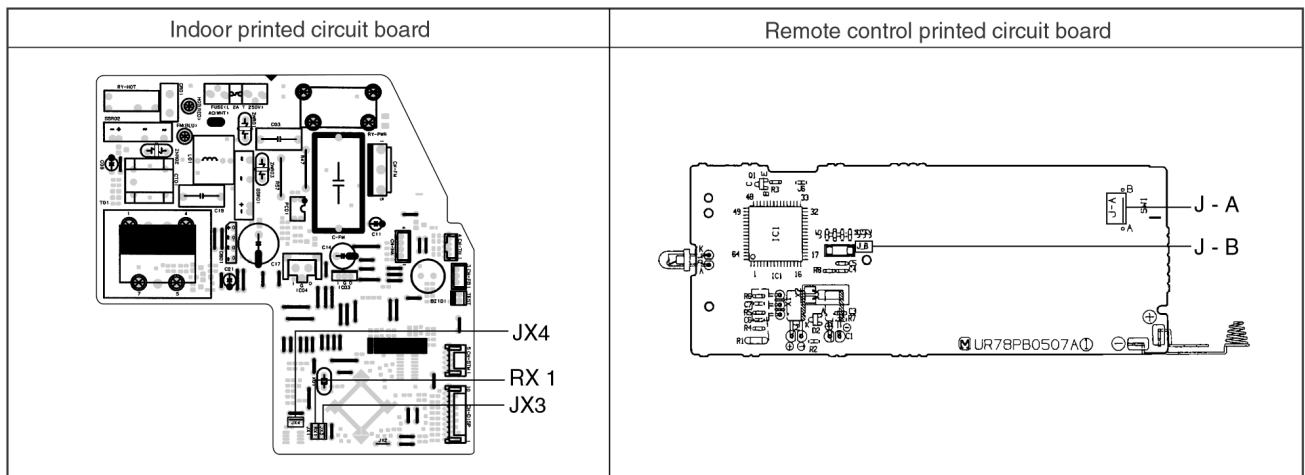

	Remote control printed circuit board		Indoor printed circuit board			Note
	J - A	J - B	JX3	JX4	RX 1	
0	SHORT	OPEN	SHORT	SHORT	—	At product delivery
1	OPEN	OPEN	SHORT	OPEN	—	
2	SHORT	SHORT	OPEN	OPEN	10 KΩ	
3	OPEN	SHORT	SHORT	OPEN	10 KΩ	

13 Troubleshooting Guide

13.1. Refrigeration cycle system

In order to diagnose malfunctions, make sure that there are no electrical problems before inspecting the refrigeration cycle. Such problems include insufficient insulation, problem with the power source, malfunction of a compressor and a fan.

The normal outlet air temperature and pressure of the refrigeration cycle depends on various conditions, the standard values for them are shown in the table on the right.

Normal Pressure and Outlet Air Temperature (Standard)

	Gas pressure Mpa (kg/cm ² G)	Outlet air temperature (°C)
Cooling Mode	0.4 ~ 0.6 (4 ~ 6)	12 ~ 16

* Condition: Indoor fan speed; High
Outdoor temperature: 35°C

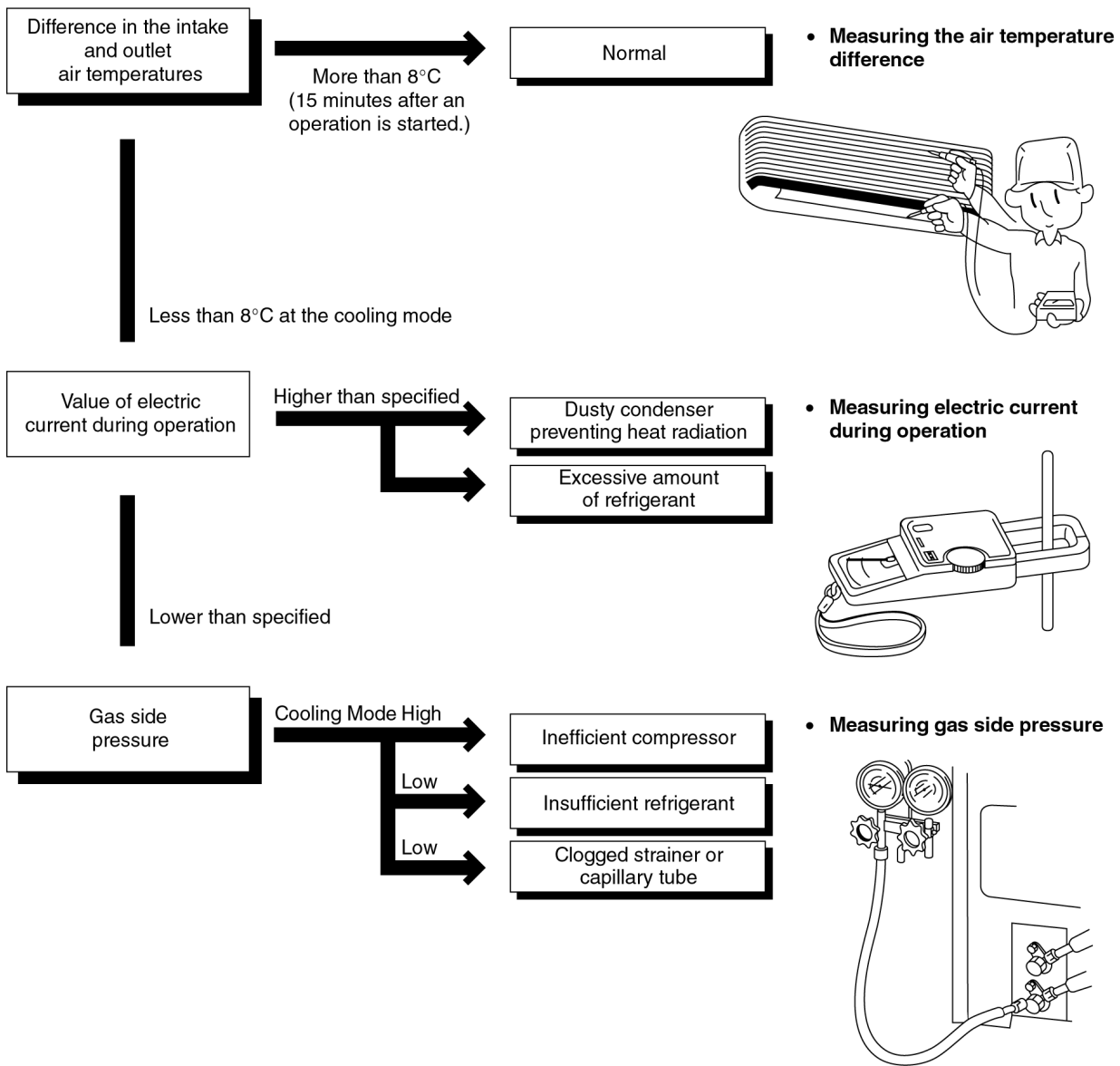

13.1.1. Relationship between the condition of the air conditioner and pressure and electric current

Condition of the air conditioner	Cooling Mode		
	Low Pressure	High Pressure	Electric current during operation
Insufficient refrigerant (gas leakage)	➔	➔	➔
Clogged capillary tube or Strainer	➔	➔	➔
Short circuit in the indoor unit	➔	➔	➔
Heat radiation deficiency of the outdoor unit	➔	➔	➔
Inefficient compression	➔	➔	➔

- Carry out the measurements of pressure, electric current, and temperature fifteen minutes after an operation is started.

13.1.2. Diagnosis methods of a malfunction of a compressor

Nature of fault	Symptom
Insufficient compressing of a compressor	<ul style="list-style-type: none"> • Electric current during operation becomes approximately 20% lower than the normal value. • The discharge tube of the compressor becomes abnormally hot (normally 70 to 90°C). • The difference between high pressure and low pressure becomes almost zero.
Locked compressor	<ul style="list-style-type: none"> • Electric current reaches a high level abnormally, and the value exceeds the limit of an ammeter. In some cases, a breaker turns off. • The compressor has a humming sound.

14 Technical Data

Thermostat characteristics

CS-C7BK / CS-C9BK / CS-C12BK

Cooling

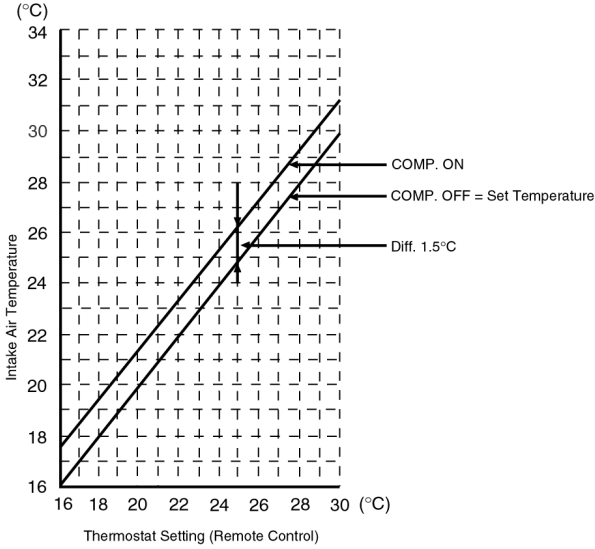

Soft Dry

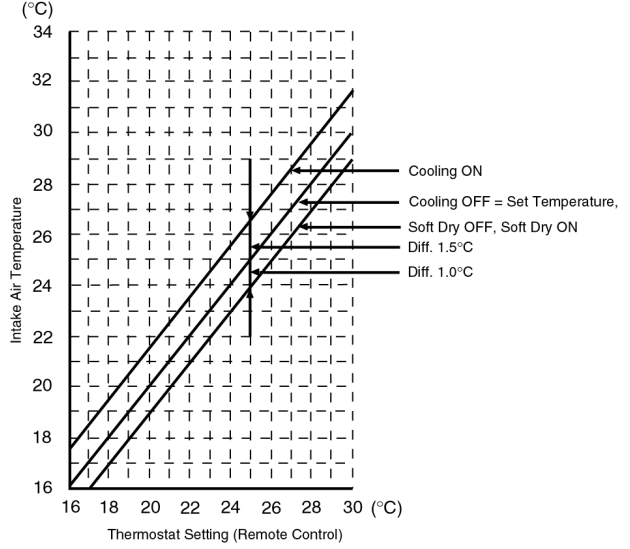

Operation characteristics

CS-C9BK / CU-2C14BK

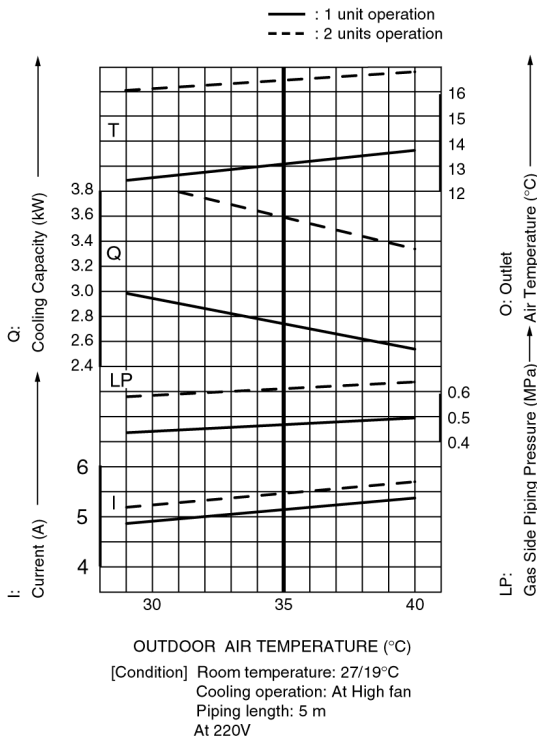

CS-C9BK / CU-2C18BK

The capability value shown is the value for one unit.
For a total for two units, multiply by 2.

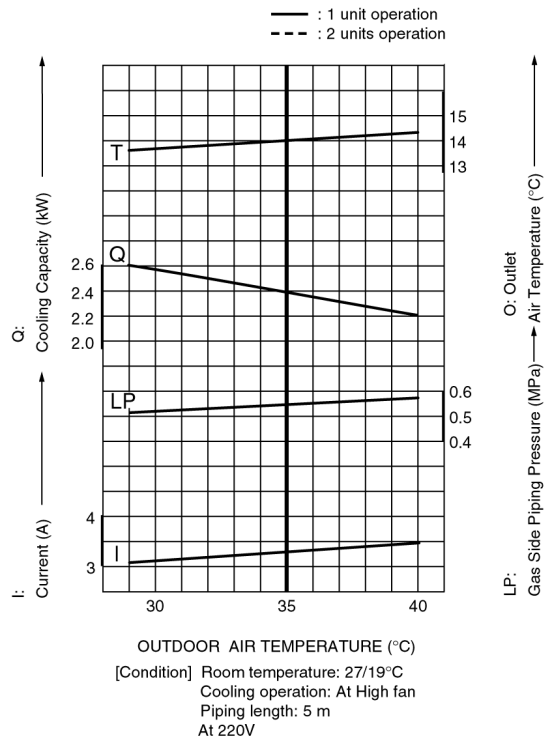

■ Operation characteristics

CS-C9BK / CU-3C20BK

● 1 Unit Operation

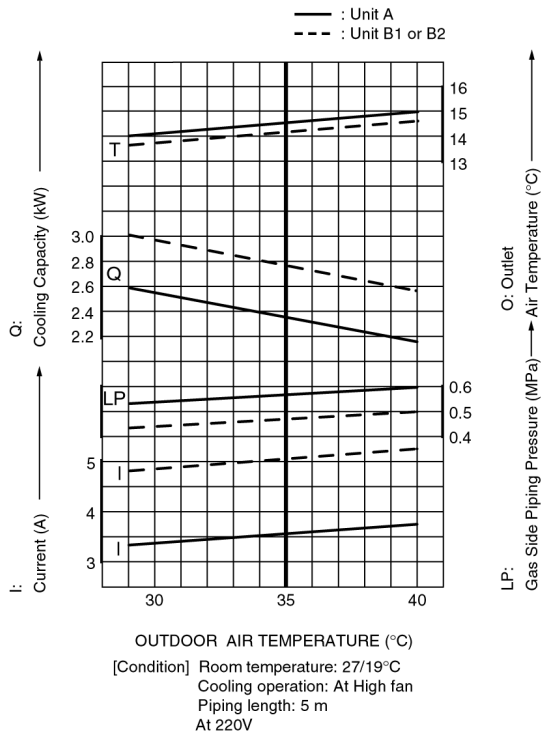

● 3 Units Operation

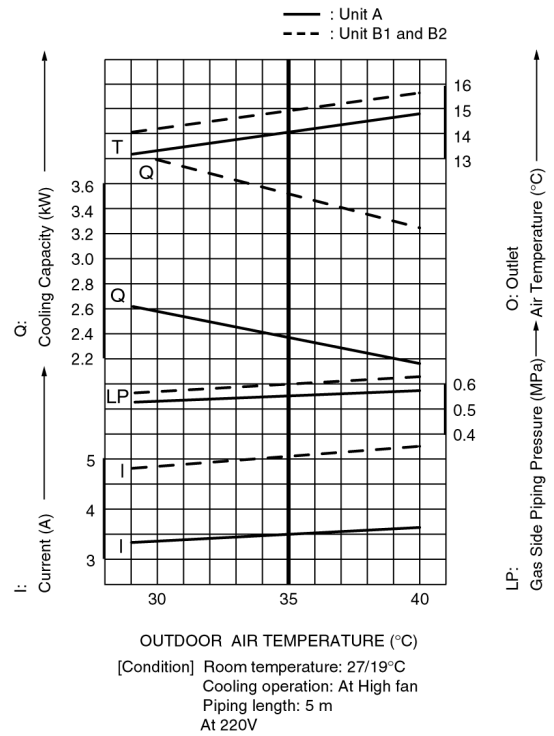

● 2 Units Operation (A + B1 or B2)

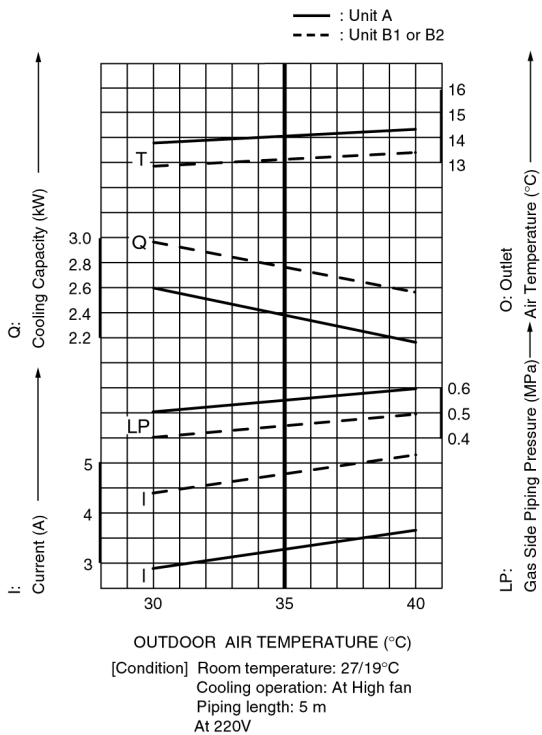

● 2 Units Operation (B1 + B2)

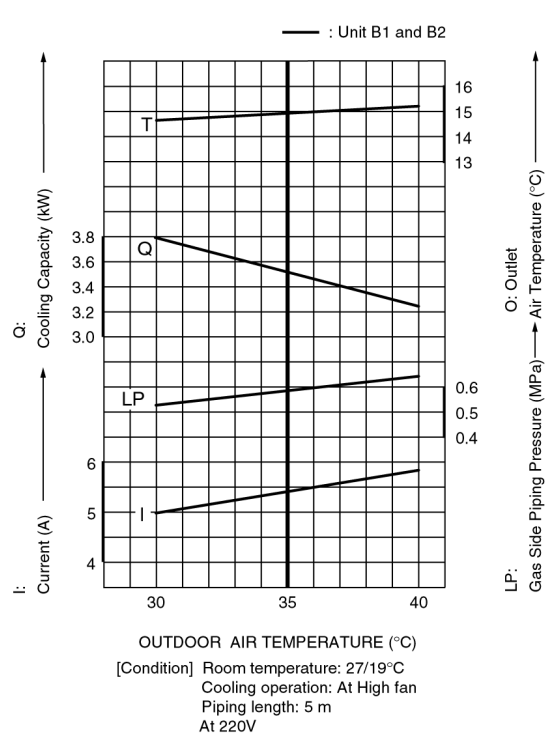

CS-C7BK / CU-2C19BK

• Cooling Characteristic

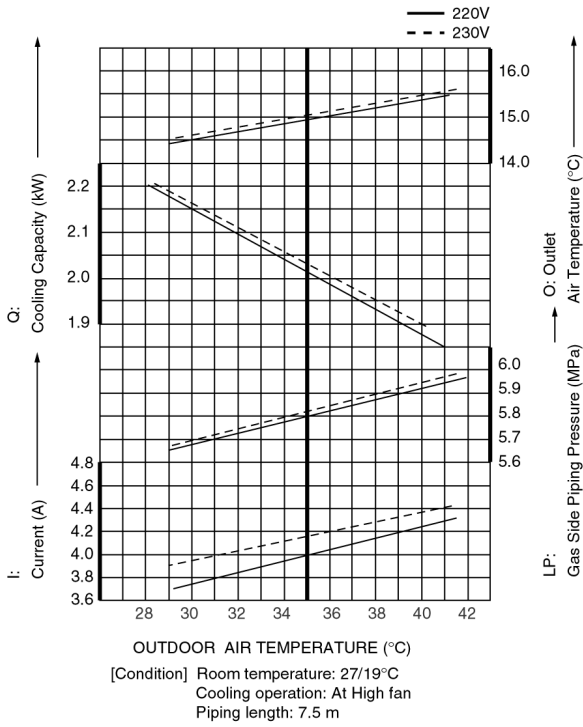

• Piping Length Characteristic

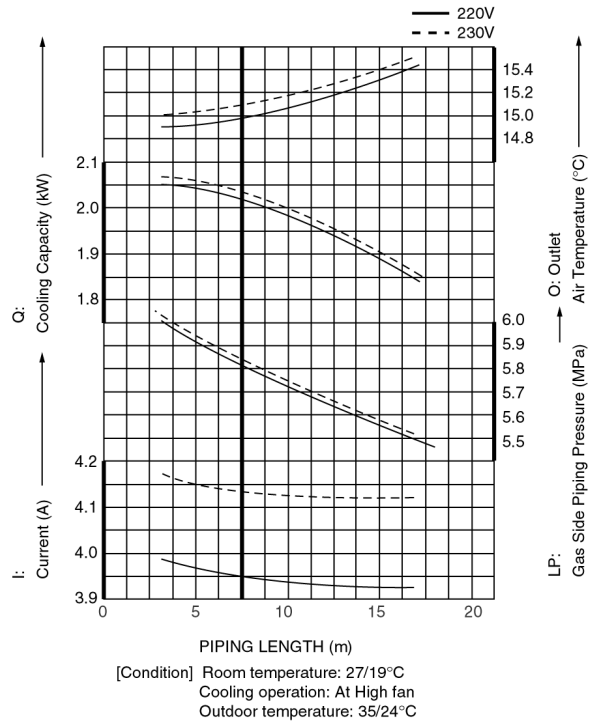

CS-C12BK / CU-2C19BK

• Cooling Characteristic

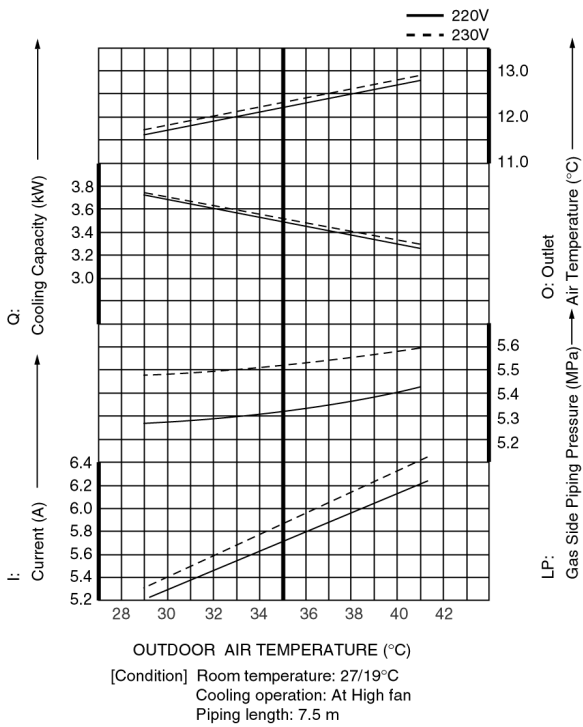

• Piping Length Characteristic

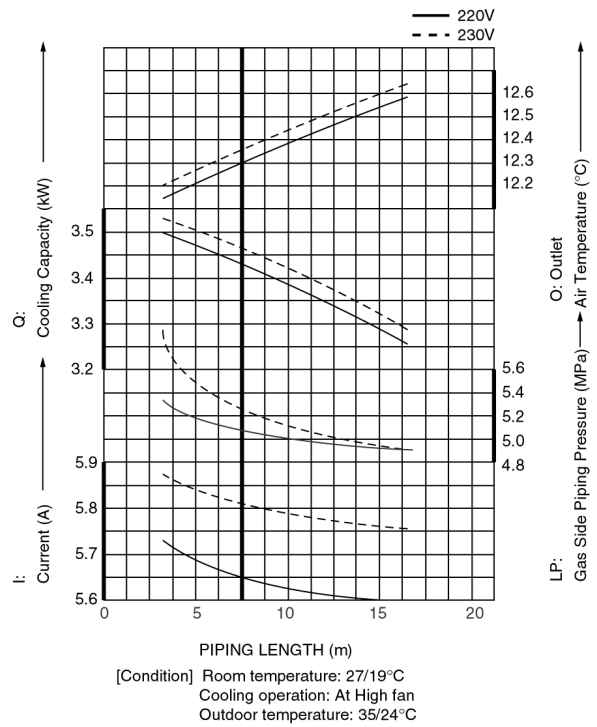

■ Sensible Capacity Chart

• CS-C9BK / CU-2C14BK (1 unit)

230V		Outdoor Temp. (°C)											
Indoor wet bulb temp.	30			35			40			46			
	TC	SHC	IP	TC	SHC	IP	TC	SHC	IP	TC	SHC	IP	
17.0°C	2.80	2.12	1.05	2.61	2.03	1.13	2.43	1.95	1.21	2.21	1.86	1.31	
19.0°C				2.82		1.15							
19.5°C	3.07	2.22	1.07	2.87	2.13	1.15	2.67	2.05	1.24	2.43	1.95	1.33	
22.0°C	3.35	2.30	1.09	3.13	2.21	1.18	2.91	2.14	1.26	2.65	2.04	1.36	

220V		Outdoor Temp. (°C)											
Indoor wet bulb temp.	30			35			40			46			
	TC	SHC	IP	TC	SHC	IP	TC	SHC	IP	TC	SHC	IP	
17.0°C	2.76	2.09	1.01	2.58	2.00	1.08	2.40	1.93	1.16	2.18	1.83	1.25	
19.0°C				2.78		1.10							
19.5°C	3.03	2.19	1.03	2.83	2.10	1.10	2.63	2.02	1.18	2.39	1.93	1.27	
22.0°C	3.30	2.27	1.05	3.08	2.18	1.12	2.87	2.11	1.20	2.61	2.01	1.30	

• CS-C9BK / CU-2C14BK (2 units)

230V		Outdoor Temp. (°C)											
Indoor wet bulb temp.	30			35			40			46			
	TC	SHC	IP	TC	SHC	IP	TC	SHC	IP	TC	SHC	IP	
17.0°C	3.59	2.72	1.12	3.36	2.61	1.20	3.12	2.51	1.29	2.84	2.38	1.39	
19.0°C				3.62		1.22							
19.5°C	3.94	2.85	1.14	3.69	2.74	1.22	3.43	2.64	1.31	3.12	2.51	1.41	
22.0°C	4.30	2.96	1.16	4.01	2.84	1.25	3.74	2.74	1.33	3.40	2.61	1.44	

220V		Outdoor Temp. (°C)											
Indoor wet bulb temp.	30			35			40			46			
	TC	SHC	IP	TC	SHC	IP	TC	SHC	IP	TC	SHC	IP	
17.0°C	3.55	2.69	1.06	3.32	2.58	1.14	3.09	2.48	1.22	2.81	2.36	1.32	
19.0°C				3.58		1.16							
19.5°C	3.90	2.82	1.08	3.64	2.71	1.16	3.39	2.61	1.25	3.08	2.48	1.34	
22.0°C	4.25	2.92	1.10	3.97	2.81	1.19	3.69	2.71	1.27	3.36	2.59	1.37	

• CS-C9BK / CU-2C18BK (1 unit)

230V		Outdoor Temp. (°C)											
Indoor wet bulb temp.	30			35			40			46			
	TC	SHC	IP	TC	SHC	IP	TC	SHC	IP	TC	SHC	IP	
17.0°C	2.42	1.83	0.71	2.26	1.76	0.76	2.10	1.69	0.81	1.91	1.61	0.88	
19.0°C				2.44		0.77							
19.5°C	2.66	1.92	0.72	2.48	1.85	0.77	2.31	1.78	0.83	2.10	1.69	0.89	
22.0°C	2.90	1.99	0.73	2.71	1.92	0.79	2.52	1.85	0.84	2.29	1.76	0.91	

220V		Outdoor Temp. (°C)											
Indoor wet bulb temp.	30			35			40			46			
	TC	SHC	IP	TC	SHC	IP	TC	SHC	IP	TC	SHC	IP	
17.0°C	2.38	1.80	0.67	2.22	1.73	0.72	2.07	1.66	0.77	1.88	1.58	0.83	
19.0°C				2.40		0.73							
19.5°C	2.61	1.89	0.68	2.44	1.82	0.73	2.27	1.75	0.78	2.07	1.66	0.85	
22.0°C	2.85	1.96	0.69	2.66	1.88	0.75	2.48	1.82	0.80	2.25	1.73	0.86	

• **CS-C9BK / CU-2C18BK (2 units)**

230V		Outdoor Temp. (°C)											
Indoor wet bulb temp.	30			35			40			46			
	TC	SHC	IP	TC	SHC	IP	TC	SHC	IP	TC	SHC	IP	
17.0°C	4.84	3.67	1.41	4.52	3.52	1.52	4.21	3.38	1.62	3.83	3.21	1.75	
19.0°C				4.88		1.54							
19.5°C	5.31	3.84	1.44	4.97	3.69	1.55	4.62	3.55	1.65	4.20	3.38	1.78	
22.0°C	5.79	3.99	1.46	5.41	3.83	1.57	5.04	3.70	1.68	4.58	3.52	1.82	

220V		Outdoor Temp. (°C)											
Indoor wet bulb temp.	30			35			40			46			
	TC	SHC	IP	TC	SHC	IP	TC	SHC	IP	TC	SHC	IP	
17.0°C	4.76	3.61	1.34	4.45	3.46	1.44	4.14	3.33	1.54	3.76	3.16	1.66	
19.0°C				4.80		1.46							
19.5°C	5.23	3.78	1.36	4.89	3.63	1.47	4.55	3.50	1.57	4.13	3.33	1.69	
22.0°C	5.70	3.92	1.39	5.32	3.77	1.49	4.95	3.64	1.60	4.50	3.47	1.72	

• **CS-C9BK / CU-3C20BK (A unit)**

230V		Outdoor Temp. (°C)											
Indoor wet bulb temp.	30			35			40			46			
	TC	SHC	IP	TC	SHC	IP	TC	SHC	IP	TC	SHC	IP	
17.0°C	2.38	1.80	0.75	2.22	1.73	0.81	2.07	1.66	0.86	1.88	1.58	0.93	
19.0°C				2.40		0.82							
19.5°C	2.61	1.89	0.77	2.44	1.82	0.82	2.27	1.75	0.88	2.07	1.66	0.95	
22.0°C	2.85	1.96	0.78	2.66	1.88	0.84	2.48	1.82	0.90	2.25	1.73	0.97	

220V		Outdoor Temp. (°C)											
Indoor wet bulb temp.	30			35			40			46			
	TC	SHC	IP	TC	SHC	IP	TC	SHC	IP	TC	SHC	IP	
17.0°C	2.32	1.76	0.71	2.17	1.69	0.76	2.02	1.62	0.82	1.83	1.54	0.88	
19.0°C				2.34		0.77							
19.5°C	2.55	1.84	0.72	2.38	1.77	0.77	2.22	1.70	0.83	2.01	1.62	0.90	
22.0°C	2.78	1.91	0.73	2.60	1.84	0.79	2.41	1.77	0.85	2.19	1.69	0.91	

• **CS-C9BK / CU-3C20BK (B1 or B2 unit)**

230V		Outdoor Temp. (°C)											
Indoor wet bulb temp.	30			35			40			46			
	TC	SHC	IP	TC	SHC	IP	TC	SHC	IP	TC	SHC	IP	
17.0°C	2.80	2.12	1.03	2.61	2.03	1.10	2.43	1.95	1.18	2.21	1.86	1.27	
19.0°C				2.82		1.12							
19.5°C	3.07	2.22	1.04	2.87	2.13	1.12	2.67	2.05	1.20	2.43	1.95	1.30	
22.0°C	3.35	2.30	1.06	3.13	2.21	1.14	2.91	2.14	1.22	2.65	2.04	1.32	

220V		Outdoor Temp. (°C)											
Indoor wet bulb temp.	30			35			40			46			
	TC	SHC	IP	TC	SHC	IP	TC	SHC	IP	TC	SHC	IP	
17.0°C	2.76	2.09	0.98	2.58	2.00	1.05	2.40	1.93	1.13	2.18	1.83	1.22	
19.0°C				2.78		1.07							
19.5°C	3.03	2.19	1.00	2.83	2.10	1.07	2.63	2.02	1.15	2.39	1.93	1.24	
22.0°C	3.30	2.27	1.02	3.08	2.18	1.09	2.87	2.11	1.17	2.61	2.01	1.26	

• **CS-C9BK / CU-3C20BK (B1 + B2 units)**

230V		Outdoor Temp. (°C)											
Indoor wet bulb temp.	30			35			40			46			
	TC	SHC	IP	TC	SHC	IP	TC	SHC	IP	TC	SHC	IP	
17.0°C	3.57	2.71	1.11	3.34	2.60	1.19	3.10	2.49	1.28	2.82	2.37	1.38	
19.0°C				3.60		1.21							
19.5°C	3.92	2.83	1.13	3.66	2.72	1.21	3.41	2.62	1.30	3.10	2.50	1.40	
22.0°C	4.27	2.94	1.15	3.99	2.83	1.24	3.72	2.73	1.32	3.38	2.60	1.43	

220V		Outdoor Temp. (°C)											
Indoor wet bulb temp.	30			35			40			46			
	TC	SHC	IP	TC	SHC	IP	TC	SHC	IP	TC	SHC	IP	
17.0°C	3.49	2.65	1.05	3.26	2.54	1.13	3.03	2.44	1.21	2.76	2.32	1.31	
19.0°C				3.52		1.15							
19.5°C	3.83	2.77	1.07	3.58	2.66	1.15	3.33	2.56	1.24	3.03	2.44	1.33	
22.0°C	4.18	2.87	1.09	3.90	2.76	1.18	3.63	2.67	1.26	3.30	2.54	1.36	

• **CS-C9BK / CU-3C20BK (A + B1 or B2 units)**

230V		Outdoor Temp. (°C)											
Indoor wet bulb temp.	30			35			40			46			
	TC	SHC	IP	TC	SHC	IP	TC	SHC	IP	TC	SHC	IP	
17.0°C	5.18	3.93	1.69	4.84	3.76	1.82	4.50	3.62	1.95	4.09	3.44	2.10	
19.0°C				5.22		1.85							
19.5°C	5.68	4.11	1.73	5.31	3.95	1.86	4.94	3.80	1.99	4.49	3.62	2.14	
22.0°C	6.20	4.26	1.76	5.79	4.10	1.89	5.39	3.95	2.02	4.90	3.77	2.18	

220V		Outdoor Temp. (°C)											
Indoor wet bulb temp.	30			35			40			46			
	TC	SHC	IP	TC	SHC	IP	TC	SHC	IP	TC	SHC	IP	
17.0°C	5.08	3.85	1.60	4.75	3.69	1.72	4.41	3.55	1.84	4.01	3.37	1.99	
19.0°C				5.12		1.75							
19.5°C	5.58	4.03	1.63	5.21	3.87	1.76	4.85	3.73	1.88	4.41	3.55	2.03	
22.0°C	6.08	4.18	1.66	5.68	4.02	1.79	5.28	3.88	1.91	4.80	3.70	2.06	

• **CS-C9BK / CU-3C20BK (A + B1 + B2 units)**

230V		Outdoor Temp. (°C)											
Indoor wet bulb temp.	30			35			40			46			
	TC	SHC	IP	TC	SHC	IP	TC	SHC	IP	TC	SHC	IP	
17.0°C	5.95	4.51	1.76	5.56	4.33	1.89	5.17	4.16	2.02	4.70	3.95	2.18	
19.0°C				6.00		1.92							
19.5°C	6.53	4.72	1.79	6.11	4.54	1.93	5.68	4.37	2.06	5.17	4.16	2.22	
22.0°C	7.12	4.90	1.82	6.65	4.71	1.96	6.19	4.54	2.10	5.63	4.33	2.26	

220V		Outdoor Temp. (°C)											
Indoor wet bulb temp.	30			35			40			46			
	TC	SHC	IP	TC	SHC	IP	TC	SHC	IP	TC	SHC	IP	
17.0°C	5.81	4.41	1.69	5.43	4.23	1.81	5.05	4.06	1.94	4.59	3.86	2.09	
19.0°C				5.86		1.84							
19.5°C	6.38	4.61	1.72	5.97	4.43	1.85	5.55	4.27	1.98	5.05	4.06	2.13	
22.0°C	6.96	4.79	1.75	6.50	4.60	1.88	6.05	4.44	2.01	5.50	4.23	2.17	

• **CS-C12BK / CU-2C19BK (A unit)**

230V	Outdoor Temp. (°C)											
Indoor wet bulb temp.	30			35			40			46		
	TC	SHC	IP	TC	SHC	IP	TC	SHC	IP	TC	SHC	IP
17.0°C	3.52	2.67	1.15	3.29	2.56	1.23	3.06	2.46	1.32	2.78	2.34	1.42
19.0°C				3.55		1.25						
19.5°C	3.87	2.80	1.17	3.61	2.69	1.26	3.36	2.59	1.34	3.06	2.46	1.45
22.0°C	4.21	2.90	1.19	3.94	2.79	1.28	3.66	2.69	1.37	3.33	2.56	1.47

220V	Outdoor Temp. (°C)											
Indoor wet bulb temp.	30			35			40			46		
	TC	SHC	IP	TC	SHC	IP	TC	SHC	IP	TC	SHC	IP
17.0°C	3.49	2.65	1.13	3.26	2.54	1.21	3.03	2.44	1.30	2.76	2.32	1.40
19.0°C				3.52		1.23						
19.5°C	3.83	2.77	1.15	3.58	2.66	1.23	3.33	2.56	1.32	3.03	2.44	1.42
22.0°C	4.18	2.87	1.17	3.90	2.76	1.26	3.63	2.67	1.34	3.30	2.54	1.45

• **CS-C7BK / CU-2C19BK (B unit)**

230V	Outdoor Temp. (°C)											
Indoor wet bulb temp.	30			35			40			46		
	TC	SHC	IP	TC	SHC	IP	TC	SHC	IP	TC	SHC	IP
17.0°C	2.06	1.56	0.69	1.93	1.50	0.74	1.79	1.44	0.79	1.63	1.37	0.85
19.0°C				2.08		0.75						
19.5°C	2.27	1.64	0.70	2.12	1.57	0.75	1.97	1.51	0.81	1.79	1.44	0.87
22.0°C	2.47	1.70	0.71	2.31	1.63	0.77	2.15	1.58	0.82	1.95	1.50	0.88

220V	Outdoor Temp. (°C)											
Indoor wet bulb temp.	30			35			40			46		
	TC	SHC	IP	TC	SHC	IP	TC	SHC	IP	TC	SHC	IP
17.0°C	2.04	1.55	0.66	1.91	1.49	0.71	1.78	1.43	0.76	1.62	1.36	0.82
19.0°C				2.06		0.72						
19.5°C	2.24	1.62	0.67	2.10	1.56	0.72	1.95	1.50	0.77	1.77	1.43	0.83
22.0°C	2.45	1.68	0.68	2.28	1.62	0.74	2.13	1.56	0.79	1.93	1.49	0.85

• **CS-C12BK, CS-C7BK / CU-2C19BK (A + B units)**

230V	Outdoor Temp. (°C)											
Indoor wet bulb temp.	30			35			40			46		
	TC	SHC	IP	TC	SHC	IP	TC	SHC	IP	TC	SHC	IP
17.0°C	5.58	4.23	1.72	5.22	4.06	1.85	4.85	3.90	1.98	4.41	3.71	2.14
19.0°C				5.63		1.88						
19.5°C	6.13	4.43	1.75	5.73	4.26	1.89	5.33	4.10	2.02	4.85	3.90	2.18
22.0°C	6.68	4.60	1.79	6.24	4.42	1.92	5.81	4.26	2.05	5.28	4.07	2.22

220V	Outdoor Temp. (°C)											
Indoor wet bulb temp.	30			35			40			46		
	TC	SHC	IP	TC	SHC	IP	TC	SHC	IP	TC	SHC	IP
17.0°C	5.54	4.20	1.69	5.17	4.02	1.81	4.81	3.87	1.94	4.37	3.67	2.09
19.0°C				5.58		1.84						
19.5°C	6.08	4.39	1.72	5.68	4.22	1.85	5.28	4.06	1.98	4.80	3.87	2.13
22.0°C	6.62	4.56	1.75	6.19	4.38	1.88	5.76	4.23	2.01	5.23	4.03	2.17

TC - Total Cooling (kW)

SHC - Sensible Heat Capacity (kW)

IP - Input Power (kw)

Indoor 27°C/19°C

Outdoor 35°C/24°C

15 Exploded View

CS-C7BK / CS-C9BK / CS-C12BK

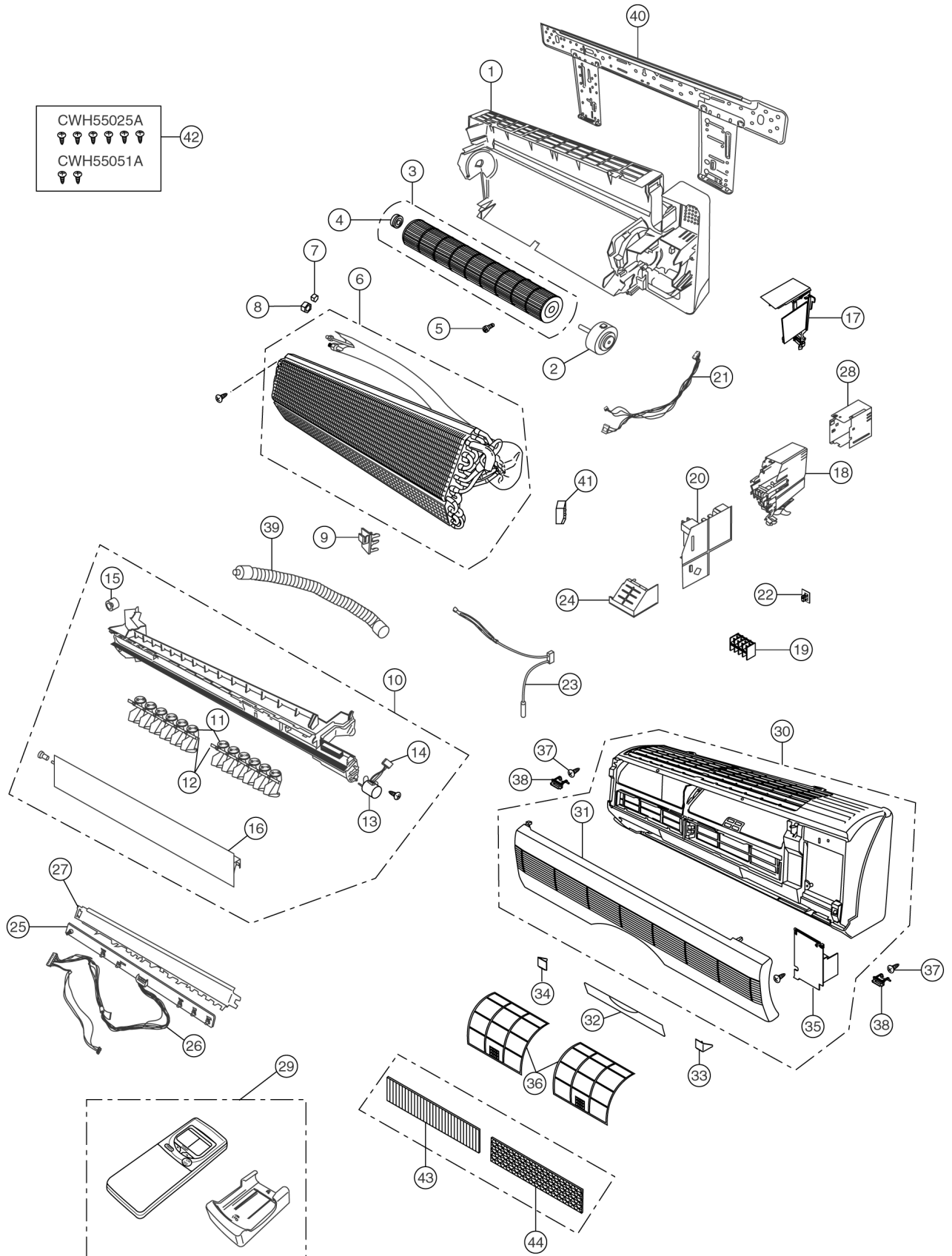

Note:

The above exploded view is for the purpose of parts disassembly and replacement.

The non-numbered parts are not kept as standard service parts.

16 Replacement Parts List

<Model: CS-C7BPKG / CS-C9BPKG / CS-C12BPKG>

REF. NO.	PART NAME & DESCRIPTION	QTY.	CS-C7BPKG	CS-C9BPKG	CS-C12BPKG	REMARKS
1	CHASSY COMPLETE	1	CWD50C1177	←	←	
2	FAN MOTOR	1	CWA921060	←	←	0
3	CROSS FLOW FAN COMPLETE	1	CWH02C1012	←	←	
4	BEARING ASS'Y	1	CWH64K007	←	←	
5	SCREW - CROSS FLOW FAN	1	CWH4580304	←	←	
6	EVAPORATOR	1	CWB30C1143	←	CWB30C1124	
7	FLARE NUT	1	CWH6002140 (1/4")	←	←	
8	FLARE NUT	1	CWT25005 (3/8")	←	CWT25007 (1/2")	
9	INTAKE AIR SENSOR HOLDER	1	CWH32142	←	←	
10	DISCHARGE GRILLE COMPLETE	1	CWE20C2101	←	←	
11	VERTICAL VANE	12	CWE241068	←	←	
12	CONNECTING BAR	2	CWE261024	←	←	
13	AIR SWING MOTOR	1	CWA98260	←	←	0
14	LEAD WIRE - AIR SWING MOTOR	1	CWA67C3977	←	←	
15	CAP - DRAIN TRAY	1	CWH52C1001	←	←	
16	HORIZONTAL VANE	1	CWE241070	←	←	
17	PARTICULAR PIECE	1	CWD932162	←	←	
18	CONTROL BOARD	1	CWH102103	←	←	
19	TERMINAL BOARD COMPLETE	1	CWA28C2082	←	←	0
20	ELECTRONIC CONTROLLER - MAIN	1	CWA742779	CWA742780	CWA742781	0
21	LEAD WIRE - FAN MOTOR	1	CWA67C3729	←	←	
22	ELECTRONIC CONTROLLER - RECEIVER	1	CWA73C1124	←	←	0
23	SENSOR COMPLETE	1	CWA50C608	←	←	0
24	CONTROL BOARD FRONT COVER	1	CWH131090	←	←	
25	ELECTRONIC CONTROLLER - INDICATOR	1	CWE39C1042	←	←	0
26	LEAD WIRE - INDICATOR	1	CWA67C3637	←	←	
27	INDICATOR HOLDER	1	CWD932163	←	←	
28	CONTROL BOARD TOP COVER	1	CWH131091	←	←	
29	REMOTE CONTROL COMPLETE	1	CWA75C2162	←	←	0
30	FRONT GRILLE COMPLETE	1	CWE11C2329	←	←	
31	INTAKE GRILLE	1	CWE221036	←	←	
32	CONTROL PANEL	1	CWE312114	←	←	
33	DECORATION BASE (R)	1	CWE351067	←	←	
34	DECORATION BASE (L)	1	CWE351068	←	←	
35	GRILLE DOOR	1	CWE141033	←	←	
36	AIR FILTER	2	CWD001047	←	←	
37	SCREW - FRONT GRILLE	2	XTN4+16C	←	←	
38	CAP - FRONT GRILLE	2	CWH521062	←	←	
39	DRAIN HOSE	1	CWH85287	←	←	
40	INSTALLATION PLATE	1	CWH36K1006	←	←	
41	ANTI-VIBRATION BUSHING	1	-	-	CWH501023	
42	BAG COMPLETE - INSTALLATION SCREW	1	CWH82C067	←	←	
43	AIR PURIFYING FILTER	1	CWMD00C0001	←	←	0
44	SOLAR DEODORIZING FILTER	1	CWMD00C0002	←	←	0

(Note)

- All parts are supplied from MACC, Malaysia (Vendor Code: 086).
- "O" marked parts are recommended to be kept in stock.

17 Exploded View

CU-2C14BK

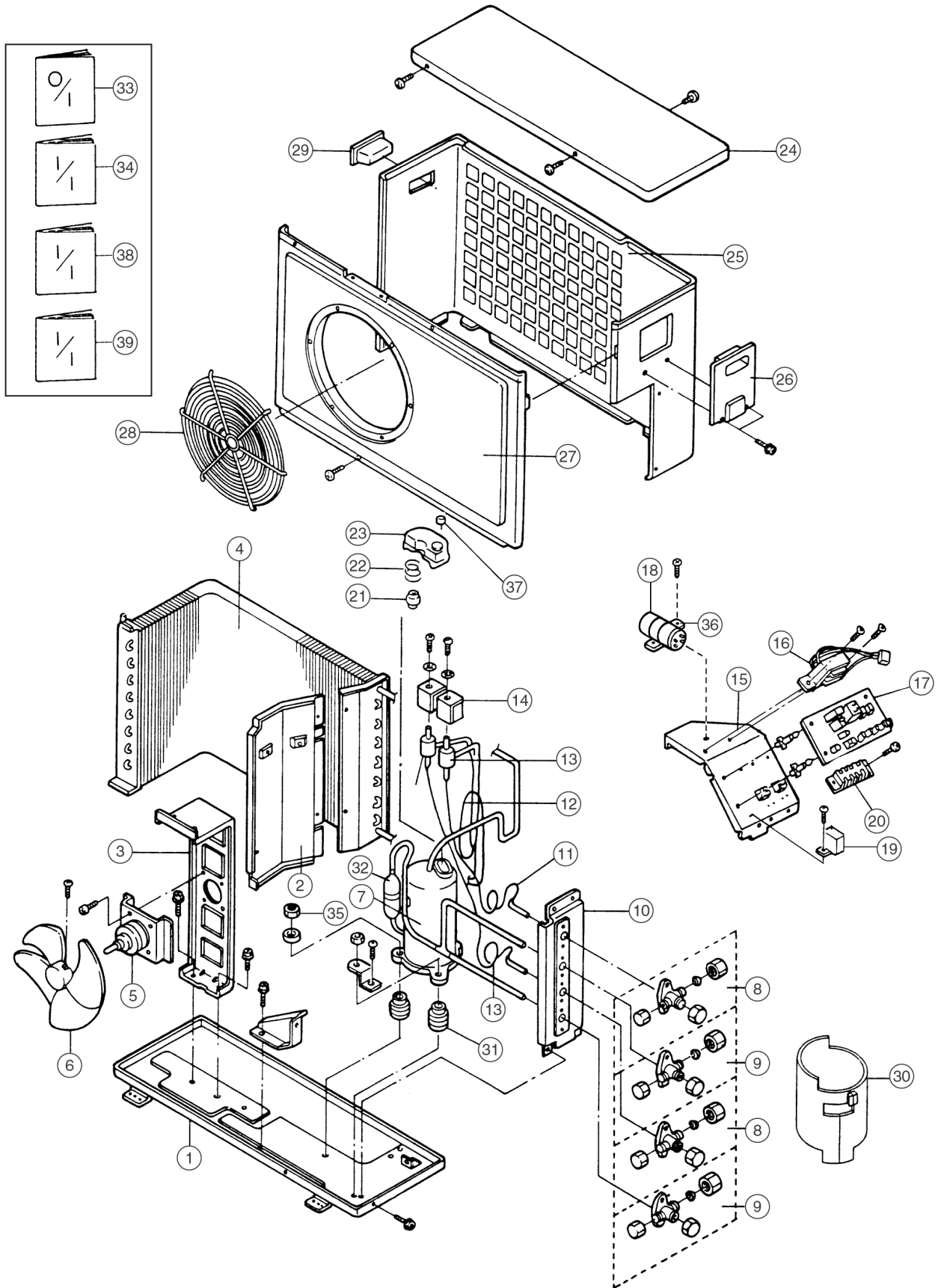

Note:

The above exploded view is for the purpose of parts disassembly and replacement.

The non-numbered parts are not kept as standard service parts.

18 Replacement Parts List

<Model: CU-2C14BKP5G>

NO.	DESCRIPTION & NAME	Q'TY	CU-2C14BKP5G	REMARKS
1	CHASSY ASS'Y	1	CWD50K573A	
2	SOUND PROOF BOARD	1	CWH15066	
3	FAN MOTOR BRACKET	1	CWD54168	
4	CONDENSER	1	CWB32C1030	
5	FAN MOTOR	1	CWA95374	0
6	PROPELLER FAN	1	CWH00022	
7	COMPRESSOR	1	2PS192D2AA02	0
8	3-WAY VALVE (LIQUID SIDE)	2	CWB01383	0
9	3-WAY VALVE (GAS SIDE)	2	CWB01384	0
10	HOLDER COUPLING	1	CWH35075A	
11	CAPILLARY TUBE	1	CWB15537	
12	CAPILLARY TUBE	2	CWB15537	
13	2 WAY VALVE	1	CWB02089	
14	V - COIL COMPLETE	1	CWA43C650	0
15	CONTROL BOARD	1	CWH10967	
16	TRANSFORMER	1	CWA40C192	0
17	ELECTRONIC CONTROLLER	1	CWA741123	0
18	CAPACITOR - COMPRESSOR	1	DS441306CPNA (440VAC, 30μF)	0
19	CAPACITOR - FAN MOTOR	1	CWA31709 (430VAC, 1μF)	0
20	TERMINAL BOARD	1	CWA28131	
21	OVERLOAD PROTECTOR	1	CWA12334	0
22	HOLDER - OVERLOAD PROTECTOR	1	CWH7041200	
23	TERMINAL COVER - COMPRESSOR	1	CWH7070204	
24	CABINET TOP PLATE	1	CWE03061A	
25	CABINET REAR PLATE	1	CWE02071A	
26	CONTROL BOARD COVER	1	CWH13236	
27	CABINET FRONT PLATE	1	CWE06C109A	
28	FAN GUARD	1	CWD04182	
29	HANDLE	1	CWE16000E	
30	SOUND - PROOF MATERIAL	1	CWG30267	
31	ANTI - VIBRATION BUSHING	3	CWH50049	
32	STRAINER	1	CWB11002	
33	OPERATING INSTRUCTION	1	CWF563436	
34	INSTALLATION INSTRUCTION	1	CWF612239	
35	NUT - COMPRESSOR	3	CWH56000	
36	HOLDER CAPACITOR	1	CWH30060	
37	NUT TERMINAL COVER	1	CWH7080300	
38	INSTALLATION INSTRUCTION	1	CWF612242	
39	INSTALLATION INSTRUCTION	1	CWF612243	

(Note)

- All parts are supplied from MACC, Malaysia (Vendor Code: 086).
- "O" marked parts are recommended to be kept in stock.

19 Exploded View

CU-2C18BK

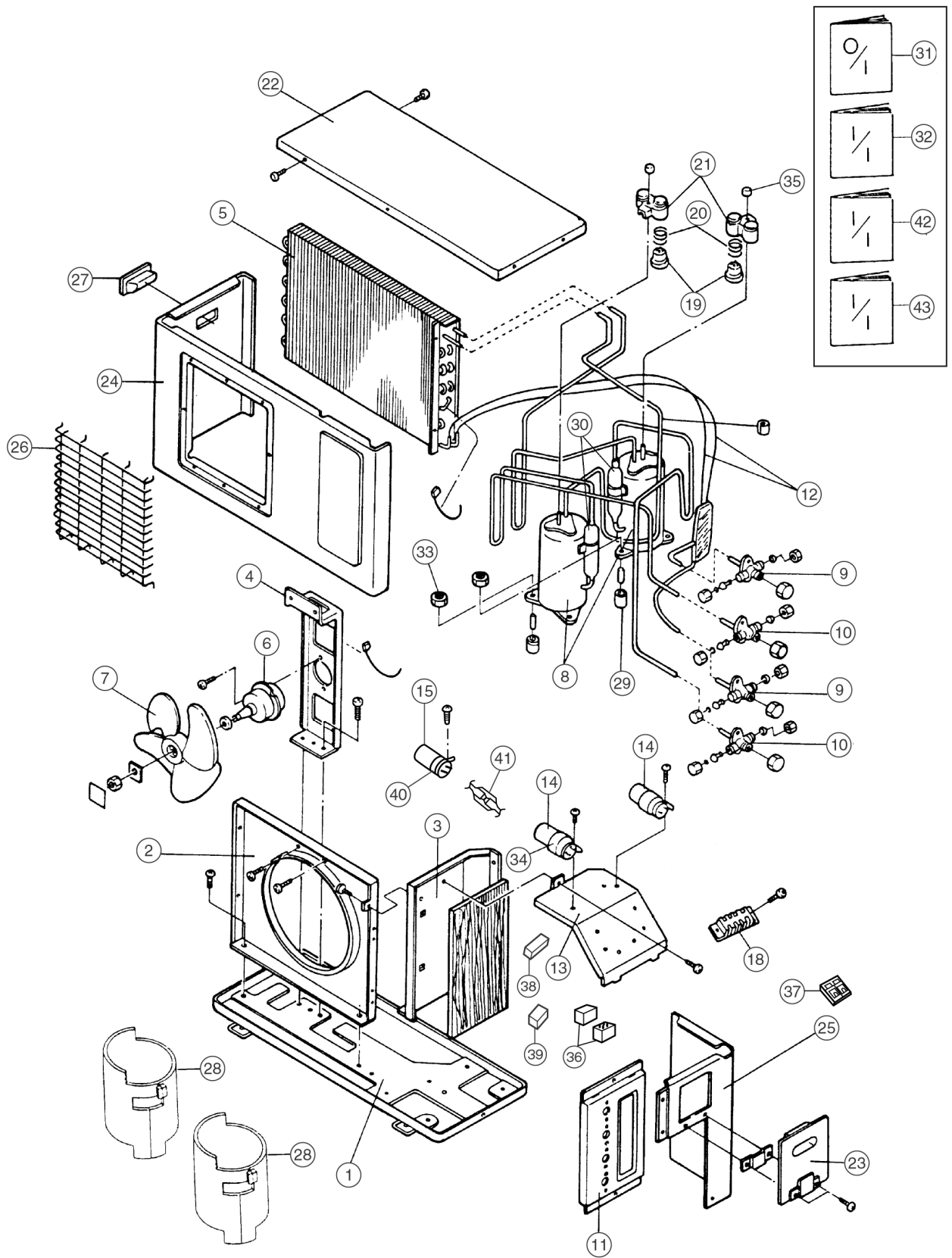

Note:

The above exploded view is for the purpose of parts disassembly and replacement.
 The non-numbered parts are not kept as standard service parts.

20 Replacement Parts List

<Model: CU-2C18BKP5G>

NO.	DESCRIPTION & NAME	Q'TY	CU-2C18BKP5G	REMARKS
1	CHASSY ASS'Y	1	CWD50R663A	
2	AIR GUIDER FOR PROPELLER FAN	1	CWD31094A	
3	SOUND PROOF BOARD	1	CWH15071	
4	FAN MOTOR BRACKET	1	CWD54179	
5	CONDENSER	1	CWB32C1028	
6	FAN MOTOR	1	CWA951179	0
7	PROPELLER FAN	1	CWH00023	
8	COMPRESSOR	2	2PS134D2AA01	0
9	3-WAY VALVE (LIQUID SIDE)	2	CWB01383	0
10	3-WAY VALVE (GAS SIDE)	2	CWB01384	0
11	HOLDER COUPLING	1	CWH35083A	
12	CAPILLARY TUBE	2	CWB15302	
13	CONTROL BOARD	1	CWH102151	
14	CAPACITOR - COMPRESSOR	2	CWA312075 (370VAC, 25 μ F)	0
15	CAPACITOR - FAN MOTOR	1	FOGAH305A002 (450VAC, 3 μ F)	0
18	TERMINAL BOARD	1	CWA281006	0
19	OVERLOAD PROTECTOR	2	CWA12336	0
20	HOLDER - OVERLOAD PROTECTOR	2	CWH7041200	
21	TERMINAL COVER - COMPRESSOR	2	CWH7070204	
22	CABINET TOP PLATE	1	CWE03C026	
23	CONTROL BOARD COVER	1	CWH13244	
24	CABINET FRONT PLATE	1	CWE06C110A	
25	CABINET SIDE PLATE	1	CWE04069A	
26	FAN GUARD	1	CWD04183	
27	HANDLE	1	CWE16000E	
28	SOUND - PROOF MATERIAL	2	CWG30267	
29	ANTI - VIBRATION BUSHING	6	CWH50049	
30	STRAINER	2	CWB11002	
31	OPERATING INSTRUCTION	1	CWF563436	
32	INSTALLATION INSTRUCTION	1	CWF612239	
33	NUT - COMPRESSOR	6	CWH56000	
34	HOLDER CAPACITOR	2	CWH30078	
35	NUT TERMINAL COVER	2	CWH7080300	
36	MAGNETIC RELAY	2	CWA4000088	
37	TERMINAL BOARD ASS'Y	1	CWA28K234	
38	TERMINAL BOARD	1	CWA4711012	
39	ELECTRONIC CONTROLLER	1	CWA742811	
40	HOLDER CAPACITOR - FAN	1	CWH301005	
41	FUSE	1	XBA2C31TR0	
42	INSTALLATION INSTRUCTION	1	CWF612242	
43	INSTALLATION INSTRUCTION	1	CWF612243	

(Note)

- All parts are supplied from MACC, Malaysia (Vendor Code: 086).
- "O" marked parts are recommended to be kept in stock.

21 Exploded View

CU-3C20BK

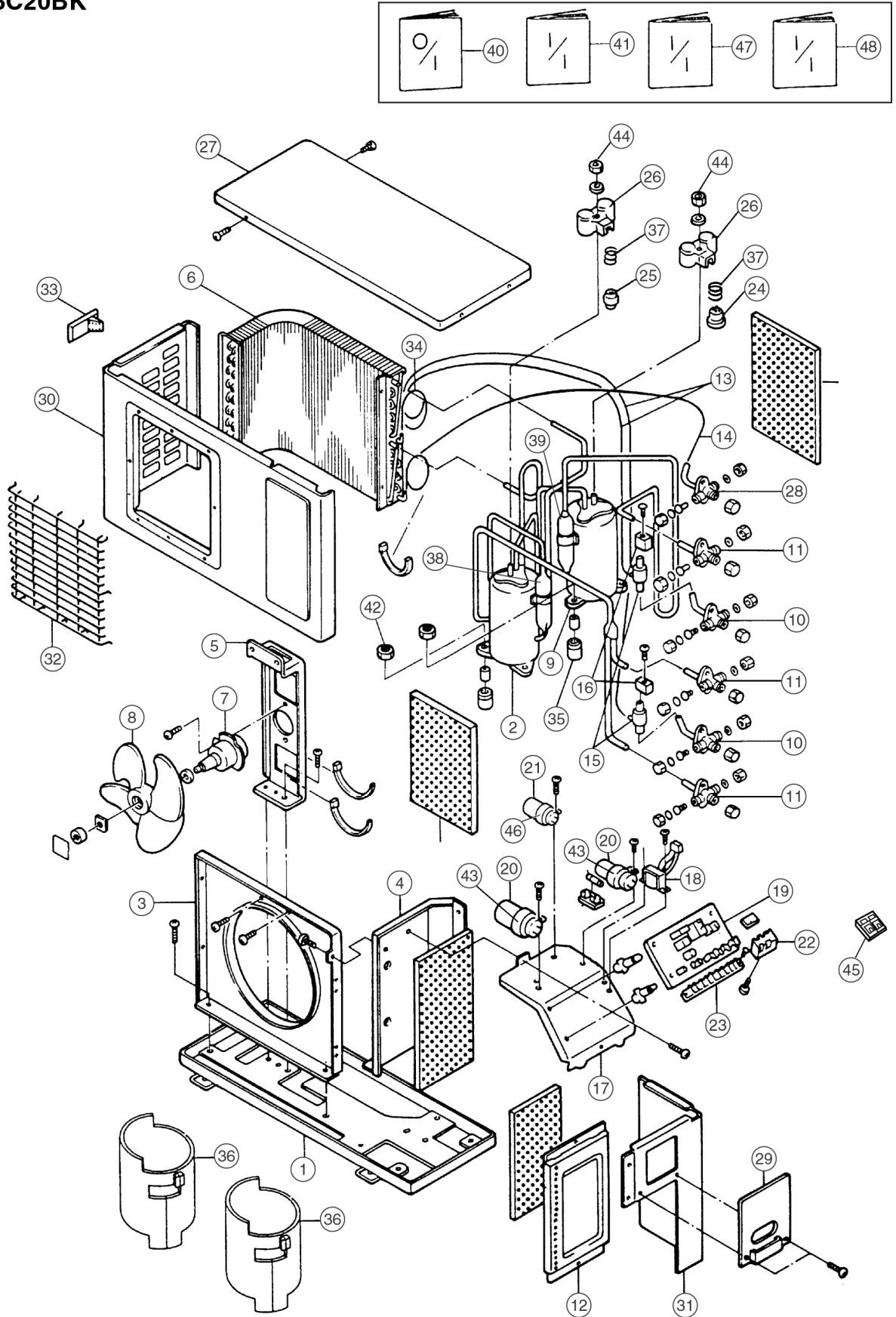

Note:

The above exploded view is for the purpose of parts disassembly and replacement.
The non-numbered parts are not kept as standard service parts.

22 Replacement Parts List

<Model: CU-3C20BKP5G>

NO.	DESCRIPTION & NAME	Q'TY	CU-3C20BKP5G	REMARKS
1	CHASSY ASS'Y	1	CWD50K663A	
2	COMPRESSOR	1	2PS193D2AA01	0
3	AIR GUIDER	1	CWD31094A	
4	SOUND PROOF BOARD	1	CWH15071	
5	FAN MOTOR BRACKET	1	CWD54179	
6	CONDENSER	1	CWB32C1029	
7	FAN MOTOR	1	CWA951179	
8	PROPELLER FAN	1	CWH00023	
9	COMPRESSOR	1	2PS134D2AA01	
10	3-WAY VALVE (LIQUID SIDE)	2	CWB01385	0
11	3-WAY VALVE (GAS SIDE)	3	CWB01384	0
12	HOLDER COUPLING	1	CWH35127A	
13	CAPILLARY TUBE	2	CWB15315	
14	CAPILLARY TUBE	1	CWB15199	
15	2-WAY VALVE	2	CWB02306	
16	V - COIL COMPLETE	1	CWA43C516	0
17	CONTROL BOARD	1	CWH102151	0
18	TRANSFORMER	1	CWA40C192	0
19	ELECTRONIC CONTROLLER	1	CWA741165	0
20	CAPACITOR - COMPRESSOR	2	DS441256CPNA (25 μ F, 440VAC)	0
21	CAPACITOR - FAN MOTOR	1	F0GAH305A002 (3.0 μ F, 450VAC)	0
22	TERMINAL BOARD	1	CWA4711012	
23	TERMINAL BOARD	1	CWA28064	
24	OVERLOAD PROTECTOR	1	CWA12336	0
25	OVERLOAD PROTECTOR	1	CWA12334	0
26	TERMINAL COVER - COMPRESSOR	2	CWH7070204	
27	CABINET TOP PLATE	1	CWE03032A	
28	3-WAY VALVE (LIQUID SIDE)	1	CWB01383	0
29	CONTROL BOARD COVER	1	CWH13322	
30	CABINET FRONT PANEL	1	CWE06C111A	
31	CABINET SIDE PLATE	1	CWE04131A	
32	FAN GUARD	1	CWD04183	
33	HANDLE	1	CWE16037C	
34	CAPILLARY TUBE	1	CWB15474	
35	ANTI - VIBRATION BUSHING	6	CWH50049	
36	SOUND PROOF MATERIAL	2	CWG30267	
37	HOLDER - OVERLOAD PROTECTOR	2	CWH7041200	
38	STRAINER	1	CWB11002	
39	STRAINER	1	CWB11004	
40	OPERATING INSTRUCTION	1	CWF563436	
41	INSTALLATION INSTRUCTION	1	CWF612239	
42	NUT - COMPRESSOR	6	CWH56000	
43	HOLDER CAPACITOR	2	CWH30078	
44	NUT - TERMINAL COVER	2	CWH7080300	
45	TERMINAL BOARD ASS'Y	1	CWA28K234	
46	HOLDER CAPACITOR - FAN	1	CWH301005	
47	INSTALLATION INSTRUCTION	1	CWF612242	
48	INSTALLATION INSTRUCTION	1	CWF612243	

(Note)

- All parts are supplied from MACC, Malaysia (Vendor Code: 086).
- "O" marked parts are recommended to be kept in stock.

23 Exploded View

CU-2C19BK

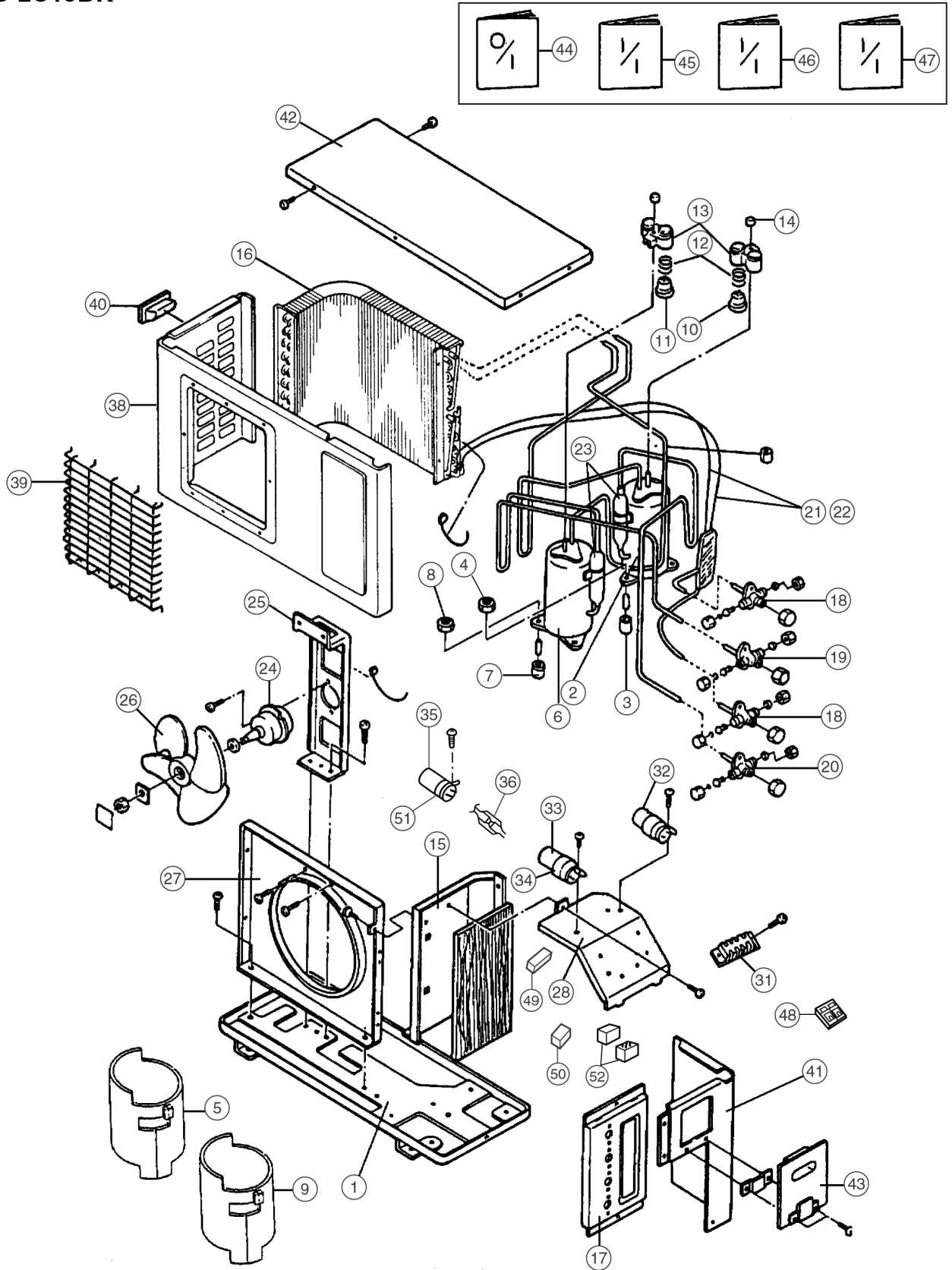

Note:

The above exploded view is for the purpose of parts disassembly and replacement.
The non-numbered parts are not kept as standard service parts.

24 Replacement Parts List

<Model: CU-2C19BK>

NO.	DESCRIPTION & NAME	Q'TY	CU-2C19BKP5G	REMARKS
1	BASE ASS'Y	1	CWD50K662A	
2	COMPRESSOR A	1	2KS224D5CA02	0
3	MOUNT RUBBER	3	CWH50055	
4	NUT	3	CWH4582065	
5	SOUND PROOF MATERIAL	1	CWG30915	
6	COMPRESSOR B	1	2RS127D3CA04	0
7	MOUNT RUBBER	3	CWH50077	
8	NUT	3	CWH56000	
9	SOUND PROOF MATERIAL	1	CWG30916	
10	OVERLOAD PROTECTOR A	1	CWA12352	0
11	OVERLOAD PROTECTOR B	1	CWA12345	0
12	HOLDER - O.L.P	2	CWH7041200	
13	TERMINAL COVER - COMP.	2	CWH171011	
14	NUT TERMINAL COVER	2	CWH7080300	
15	SOUND PROOF COVER	1	CWH15071	
16	CONDENSER	1	CWB32C1031	
17	COUPLING BRACKET	1	CWH35083A	
18	3-WAY VALVE (LIQUID SIDE)	2	CWB01383	0
19	3-WAY VALVE (GAS SIDE)	1	CWB01384	0
20	3-WAY VALVE (GAS SIDE)	1	CWB01486	0
21	CAPILLARY TUBE	1	CWB15672	
22	CAPILLARY TUBE	1	CWB15490	
23	STRAINER	2	CWB11002	
24	FAN MOTOR	1	CWA951179	0
25	FAN MOTOR BRACKET	1	CWD54179	
26	PROPELLER FAN	1	CWH00023	
27	AIR GUIDER - P. FAN	1	CWD31094A	
28	CONTROL BOARD	1	CWH102151	
31	TERMINAL BOARD	1	CWA281006	
32	CAPACITOR - COMP. A	1	DS371306CPNA	0
33	CAPACITOR - COMP. B	1	DS441156CPNA	0
34	HOLDER CAPACITOR	2	CWH30078	
35	CAPACITOR - FAN MOTOR	1	FOGAH305A002	0
36	FUSE	1	XBA2C31TR0	0
38	CABINET FRONT PLATE	1	CWE06C111A	
39	FAN GUARD	1	CWD04183	
40	HANDLE	1	CWE16037C	
41	CABINET SIDE PLATE	1	CWE04069A	
42	CABINET TOP PLATE	1	CWE03C026	
43	CONTROL BOARD COVER	1	CWH13244	
44	OPERATING INSTRUCTION	1	CWF563436	
45	INSTALLATION INSTRUCTION	1	CWF612239	
46	INSTALLATION INSTRUCTION	1	CWF612242	
47	INSTALLATION INSTRUCTION	1	CWF612243	
48	TERMINAL BOARD ASS'Y	1	CWA28K234	
49	TERMINAL BOARD	1	CWA4711012	
50	ELECTRONIC CONTROLLER	1	CWA742811	
51	HOLDER CAPACITOR - FAN	1	CWH301005	
52	MAGNETIC RELAY	2	CWA4000088	

(Note)

- All parts are supplied from MACC, Malaysia (Vendor Code: 086).
- "O" marked parts are recommended to be kept in stock.

25 Electronic Parts List

<Electronic Controller Part No.: CWA742779, CWA742780 & CWA742781>

SYMBOL	DESCRIPTION & NAME	PART NO.
BZ101	SOUND GENERATOR	A48040
C-FM	SH CAPACITOR	A31698
D08, D10, D11	DIODE	B0ACCK000005 (CWA742779 & CWA742780 only)
DB01	DIODE	A54CS1VB20E
FUSE	FUSE	XBA2C20TR0
FUSE HOLDER	FUSE HOLDER	XCSCW012
IC01	INTEGRATED CIRCUIT	A52D0022GB34
IC02	INTEGRATED CIRCUIT	C3EBDG000021
IC03	INTEGRATED CIRCUIT	A52C040
IC04	INTEGRATED CIRCUIT	A52C114
IC05	INTEGRATED CIRCUIT	A52A2003GR2
L01	V-COIL	A431036
PC01	PHOTO COUPLER	A52LP620-G4
Q01, Q02, Q03	TRANSISTOR	B1GBCFGH0001
Q04, Q05, Q06	TRANSISTOR	A55C2412KTX
RY-PWR	ELECTRO MAGNETIC RELAY	K6B1AGA00077
SSR01	TYRISTOR	A56G3MC202PL
T01	TRANSFORMER	A401030
X01	RESONATOR	A45CSTS409MG
ZD1	DIODE	B0BC7R400003
ZNR01, ZNR03	DIODE	ERZVEAV511

(Note)

- All parts are supplied from MACC, Malaysia (Vendor Code: 086)

26 Electronic Circuit Diagram

- CS-C9BKP5G / CU-2C14BKP5G
- CS-C9BKP5G / CU-2C18BKP5G
- CS-C9BKP5G / CU-3C20BKP5G
- CS-C7BKP5G / CU-2C19BKP5G
- CS-C12BKP5G

SCHEMATIC DIAGRAM 1/7

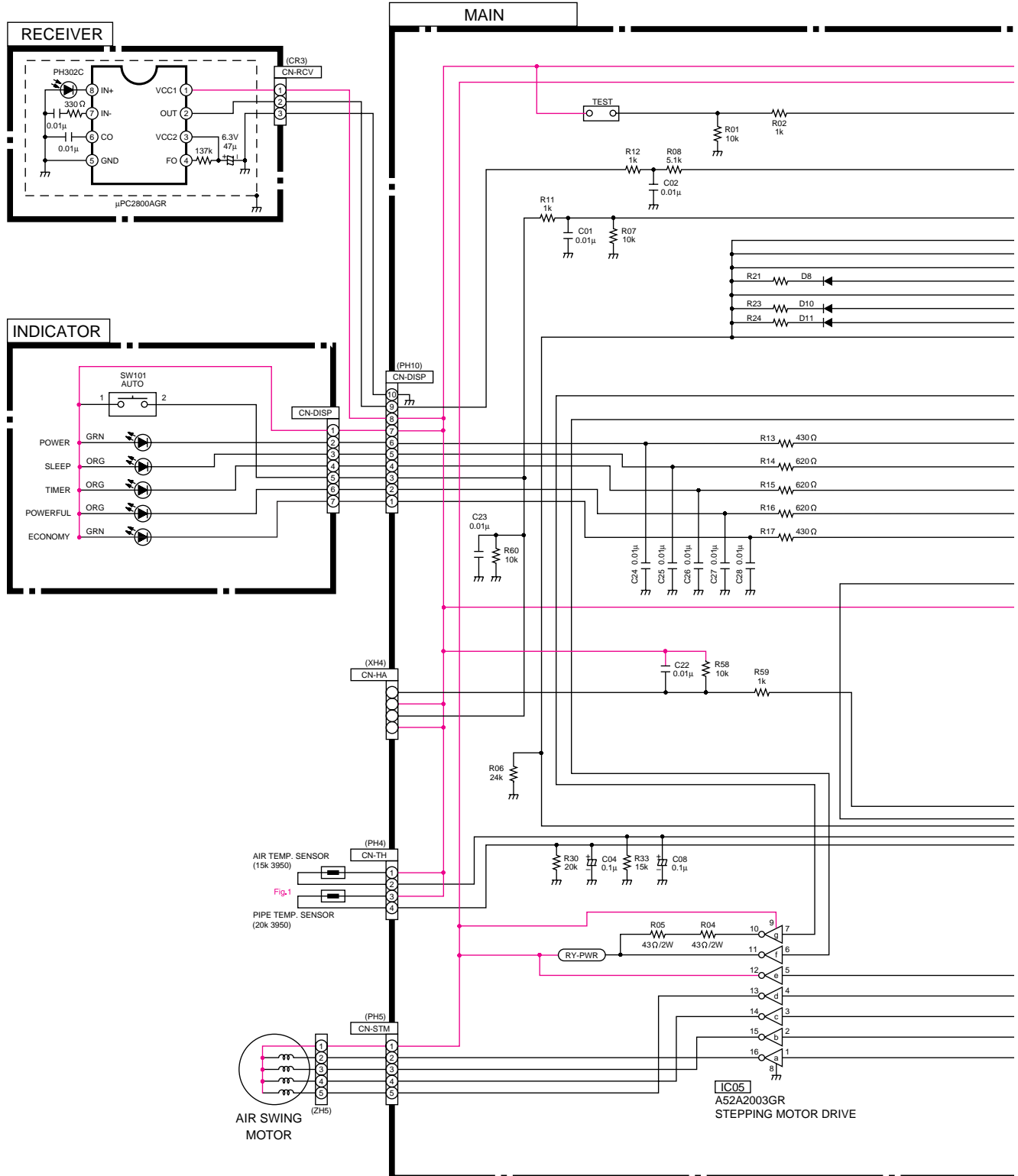

SCHEMATIC DIAGRAM 2/7

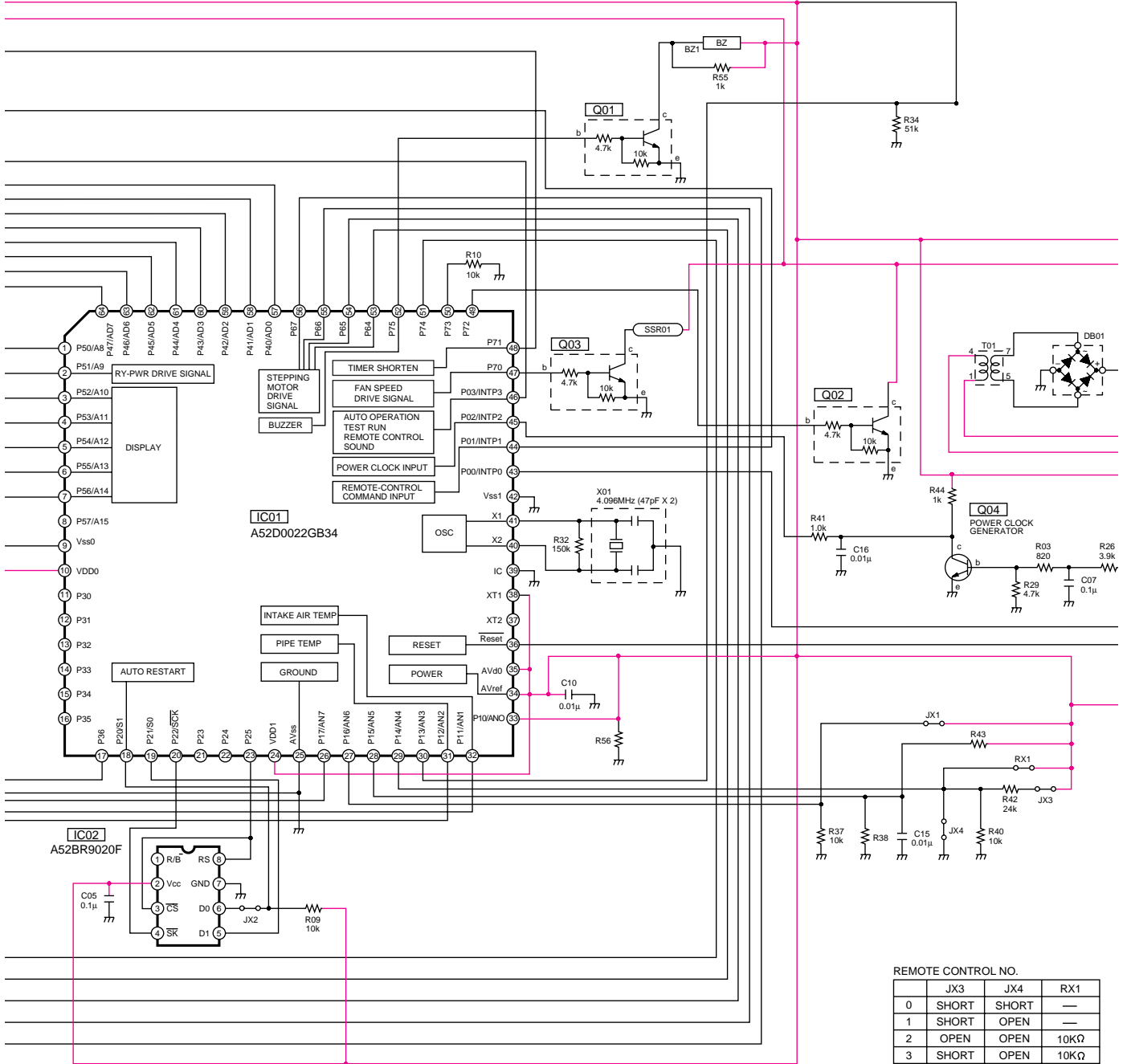

SCHEMATIC DIAGRAM 3/7

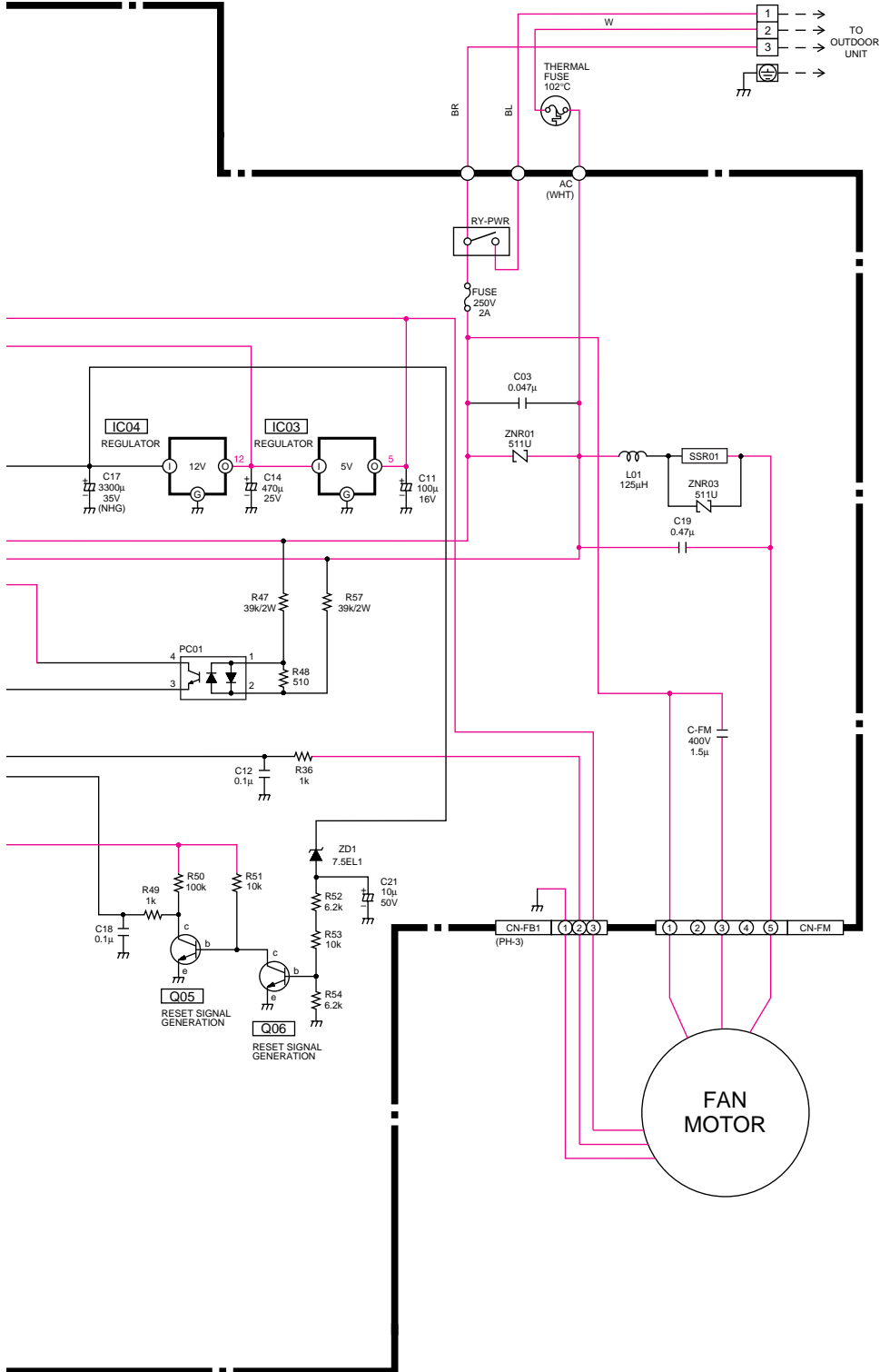

• CU-2C14BKP5G

SCHEMATIC DIAGRAM 4/7

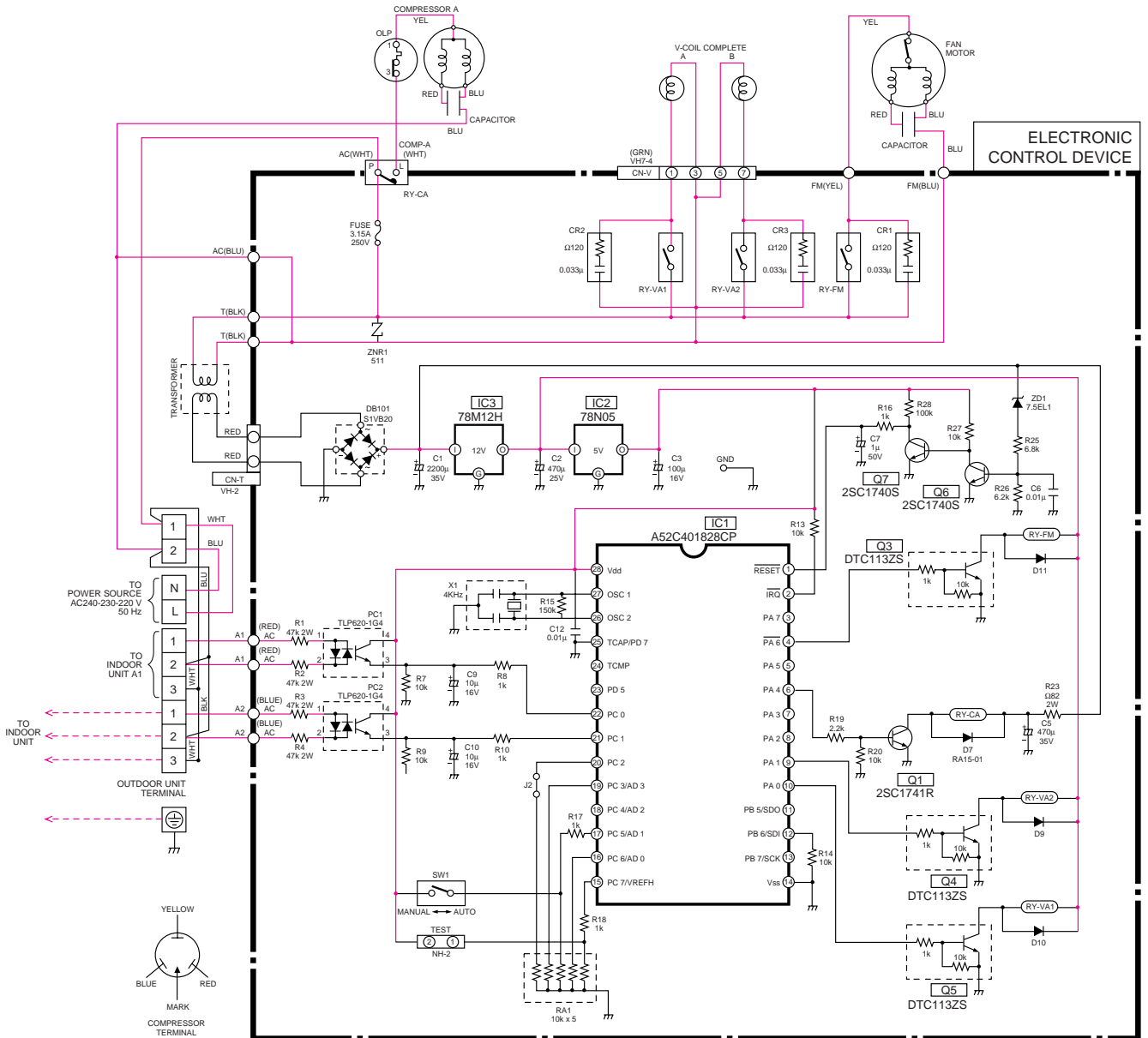

• CU-2C18BKP5G

SCHEMATIC DIAGRAM 5/7

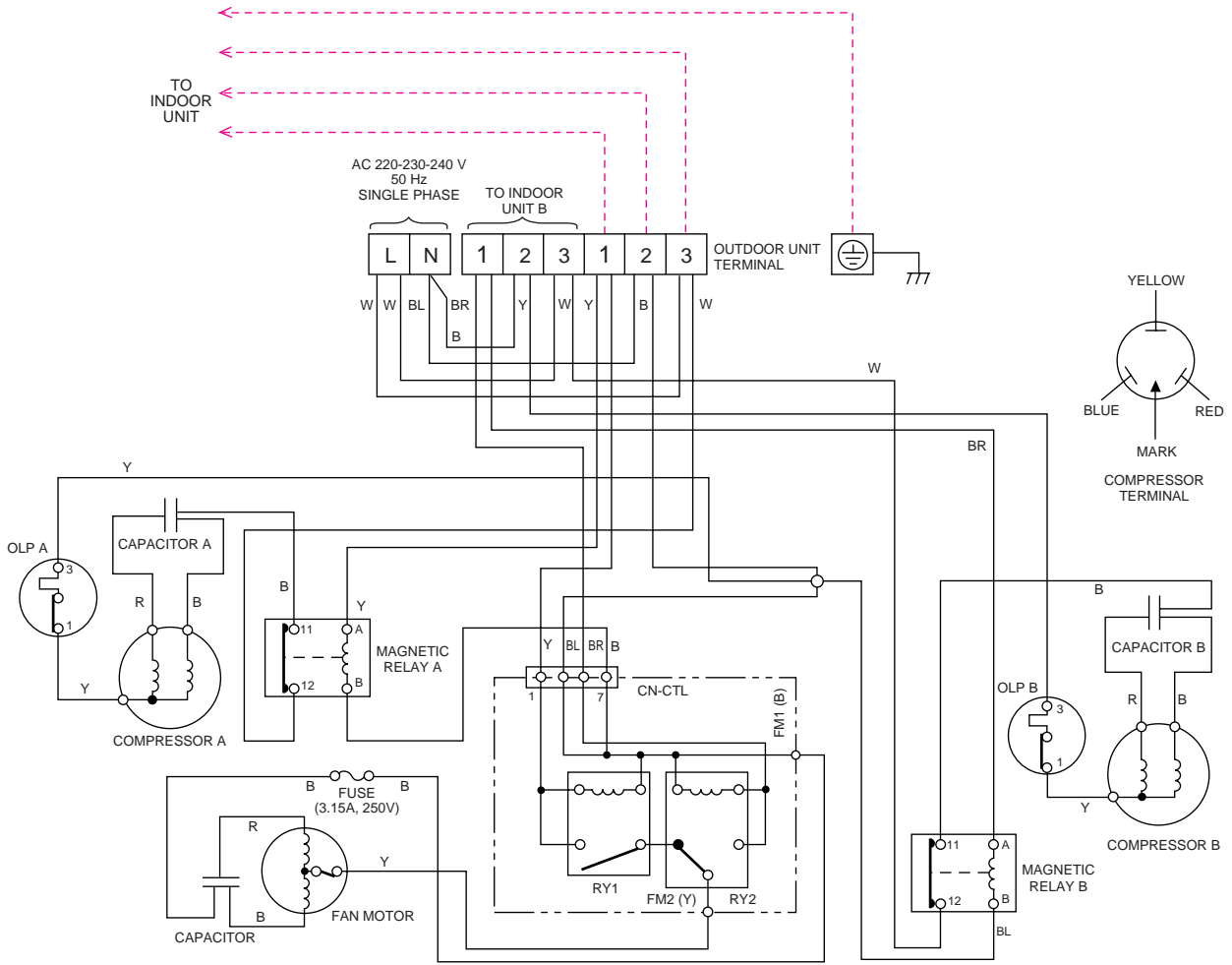

• CU-3C20BKPG5G

SCHEMATIC DIAGRAM 6/7

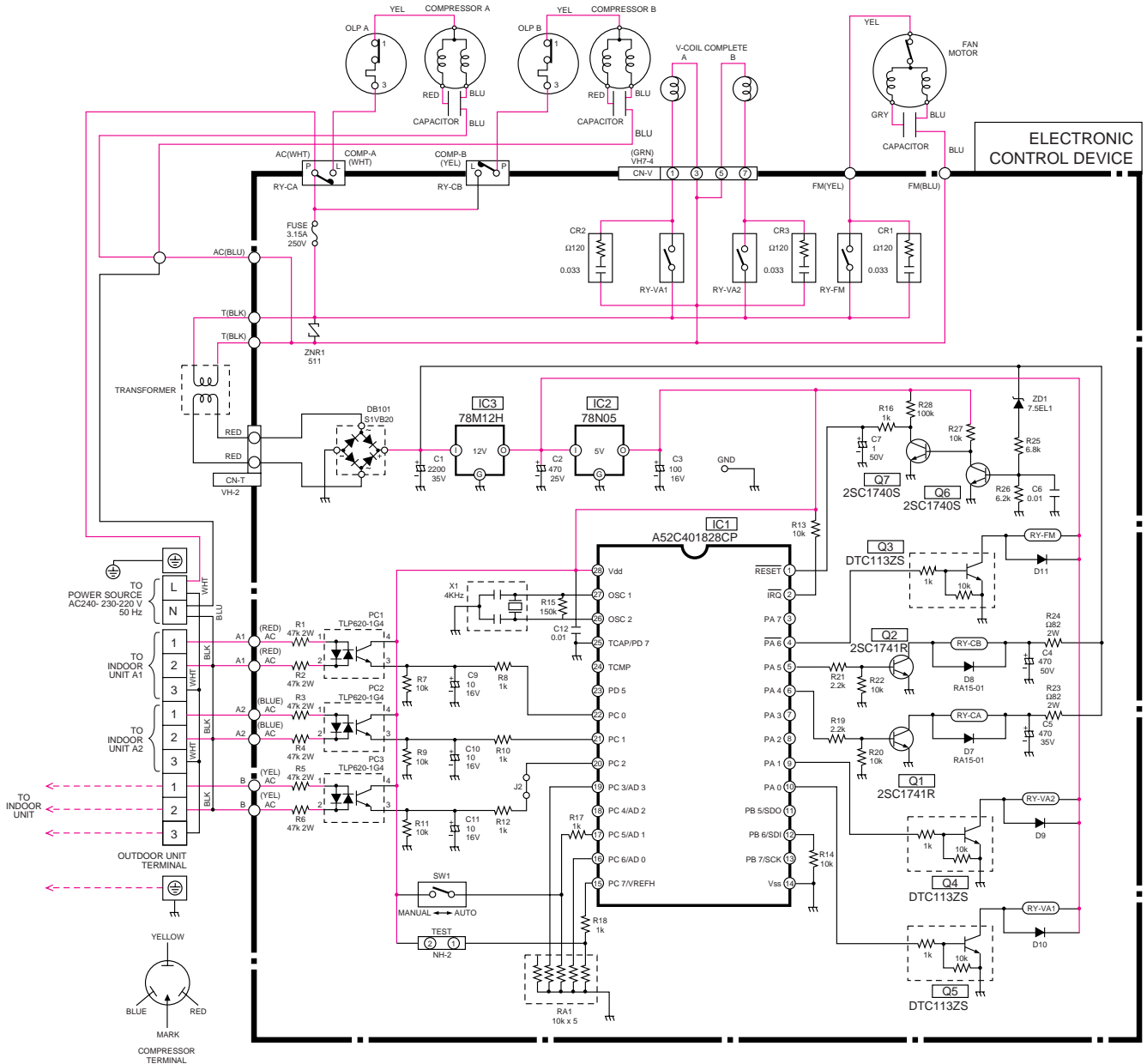

• CU-2C19BKP5G

SCHEMATIC DIAGRAM 7/7

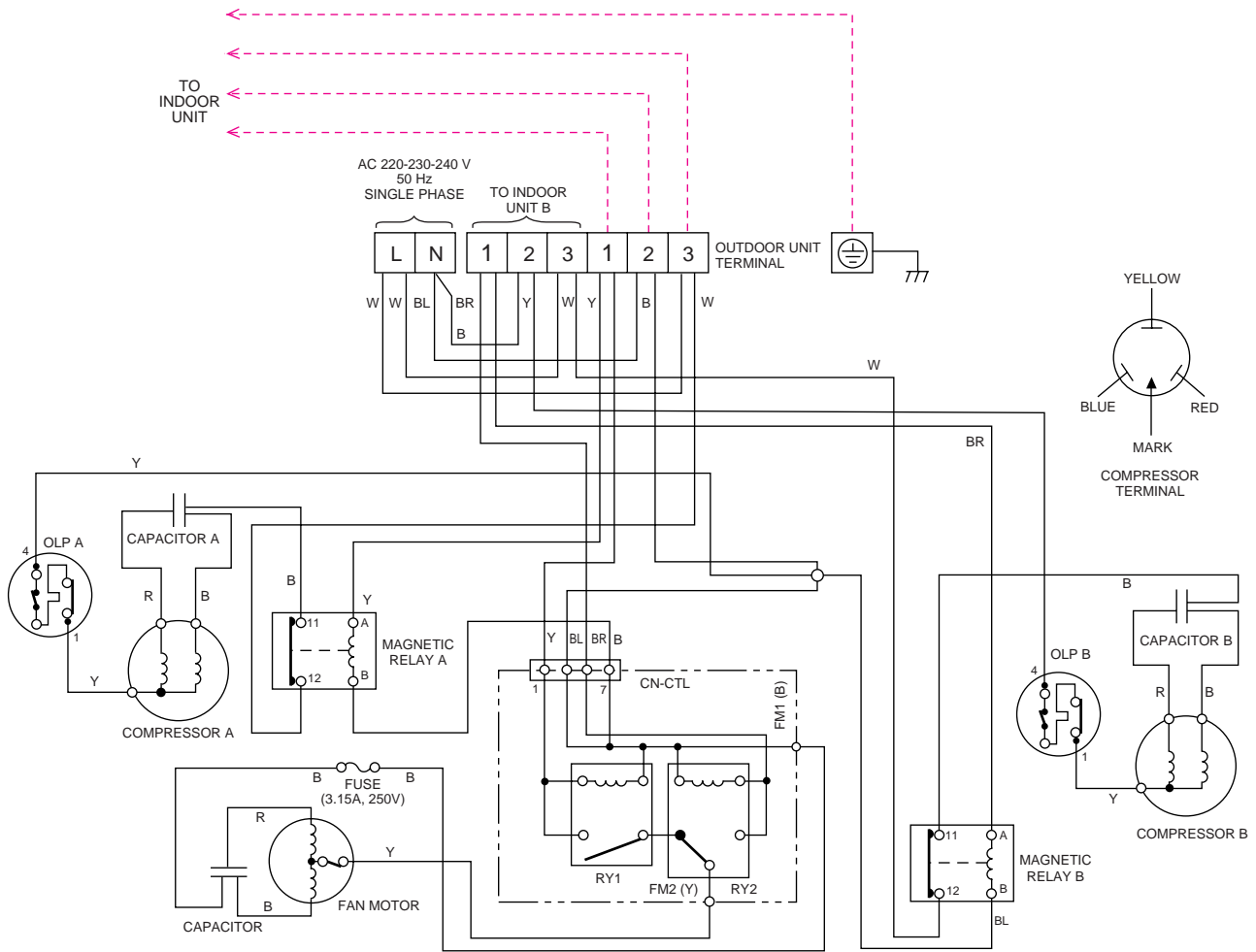

Fig. 1

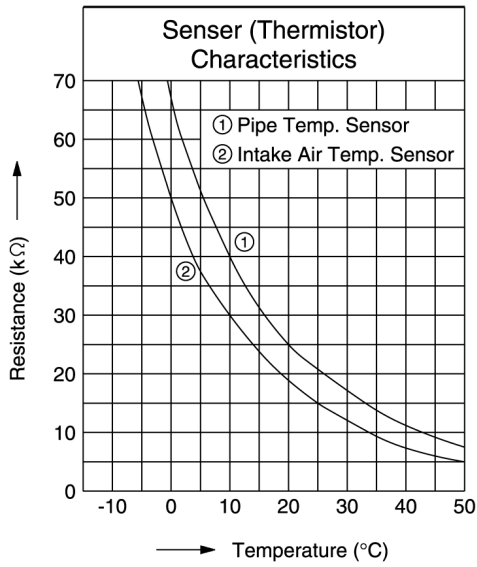

Fig. 2

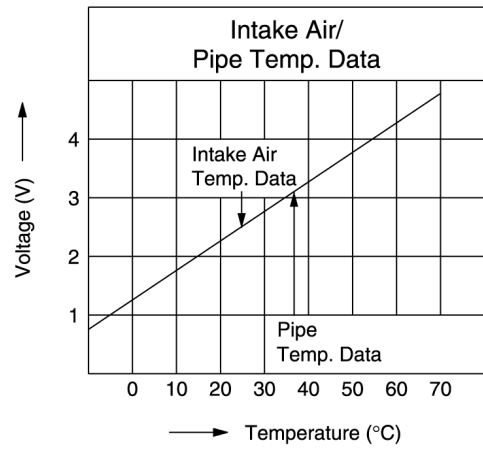
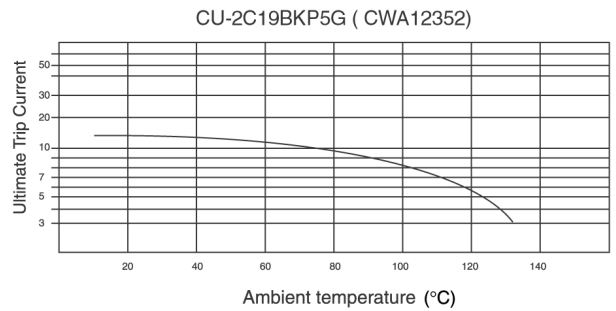
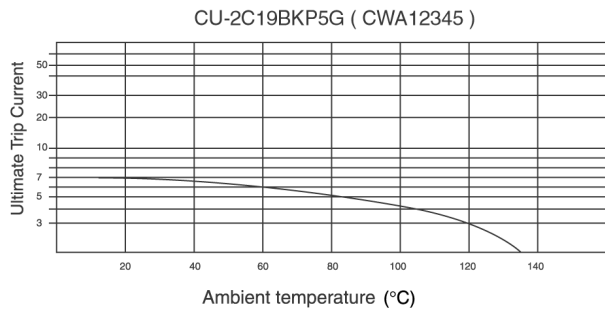
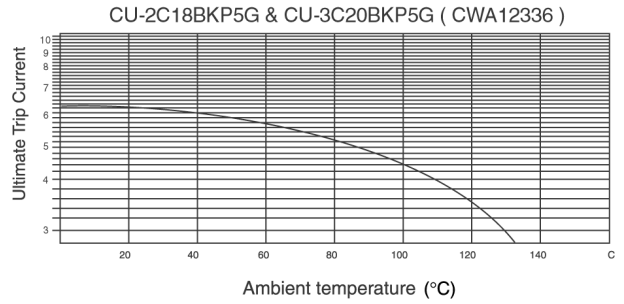
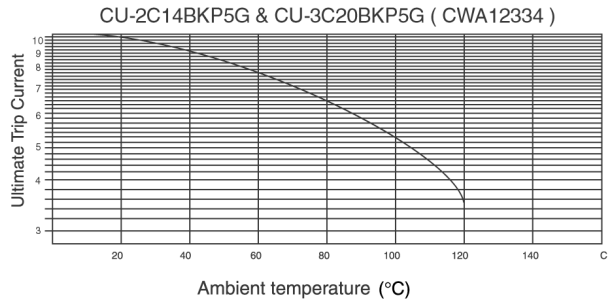

Fig. 3 OLP Characteristics (Compressor)



How to use electronic circuit diagram

Before using the circuit diagram, read the following carefully.

- * Voltage measurement
Voltage has been measured with a digital tester when the indoor fan is set at high fan speed under the following conditions without setting the timer.
Use them for servicing.
Voltage indication is in Red at all operations.

	Intake air temperature	Temperature setting	Discharge air temperature	Pipe temperature
Cooling	27°C	16°C	17°C	15°C

- * Indications for resistance
 - a. K....kΩ M....MΩ
 - W...watt Not indicated....1/4W
 - b. Type
 - Not indicated.....carbon resister
Tolerance±5%
 - metal oxide resister
Tolerance±1%

- * Indications for capacitor
 - a. Unit μ....μF P....pF
 - b. Type Not indicated....ceramic capacitor
 - (S).....S series aluminium electrolytic capacitor
 - (Z).....Z series aluminium electrolytic capacitor
 - (SU).....SU series aluminium electrolytic capacitor
 - (P).....P series polyester system
 - (SXE).....SXE series aluminium electrolytic capacitor
 - (SRA).....SRA series aluminium electrolytic capacitor
 - (KME).....KME series aluminium electrolytic capacitor

- * Diode without indication.....MA165
- * Circuit Diagram is subject to change without notice for further development.

TIMER TABLE

Name		Time	Test Mode (When test point Short-circuited)	Remarks
Sleep Mode Waiting		1 hr.	6 sec.	
Sleep Mode Operation		8 hrs.	48 sec.	
Real Timer		1 hr.	1 min.	
		10 min.	10 sec.	
		1 min.	1 sec.	
Time Delay Safety Control		2 min. 58 sec.	0 sec.	
Forced Operation		60 sec.	0 sec.	
Time Save Control		7 min.	4.2 sec.	
Anti-Freezing		4 min.	0 sec.	
Auto Mode Judgement		25 sec.	0 sec.	
Soft Dry	OFF	6 min.	36 sec.	
	ON	10 min.	60 sec.	Soft Dry: 10 min. operation
Deodorizing Control	Cooling	40 sec.	4 sec.	
		70 sec.	7 sec.	
		20 sec.	2 sec.	
		180 sec.	18 sec.	
	Soft Dry	40 sec.	4 sec.	
		360 sec.	36 sec.	
Comp. Reverse Rotation Detection		5 min.	30 sec.	Comp. ON 5 min. and above
		2 min.	0 sec.	
Comp./ Fan Motor Delay Timer		1.6 sec.	0 sec.	
Powerful Mode Operation		15 min.	15 sec.	
Random FM Timer (Economy Mode)		5 sec.	5 sec.	
Random Auto Restart Control		0 ~ 62 sec.	0 ~ 6.2 sec.	

26.1. REMOTE CONTROL

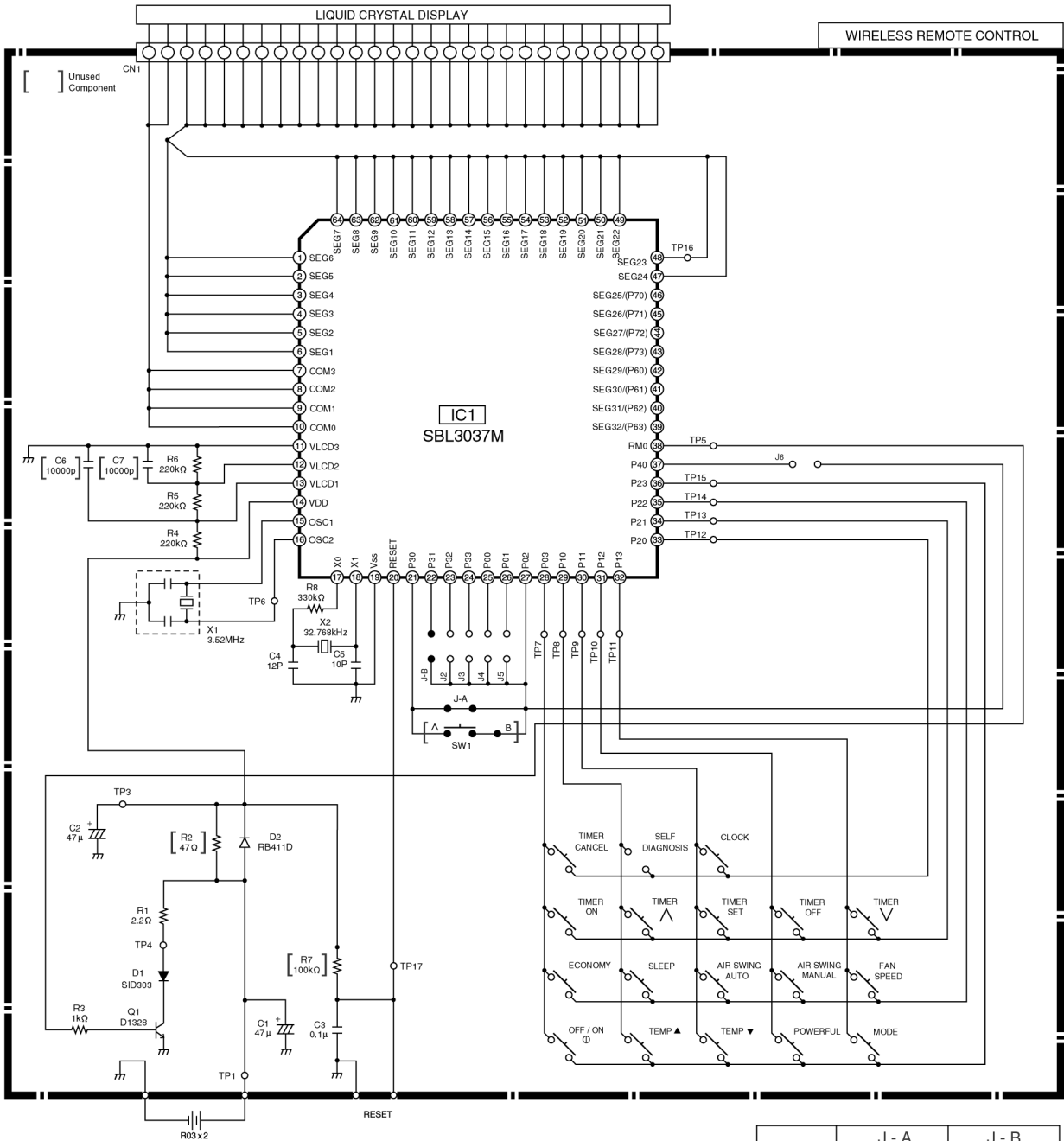

	J - A	J - B
0	SHORT	OPEN
1	OPEN	OPEN
2	SHORT	SHORT
3	OPEN	SHORT

26.2. PRINT PATTERN INDOOR UNIT PRINTED CIRCUIT BOARD

TOP VIEW

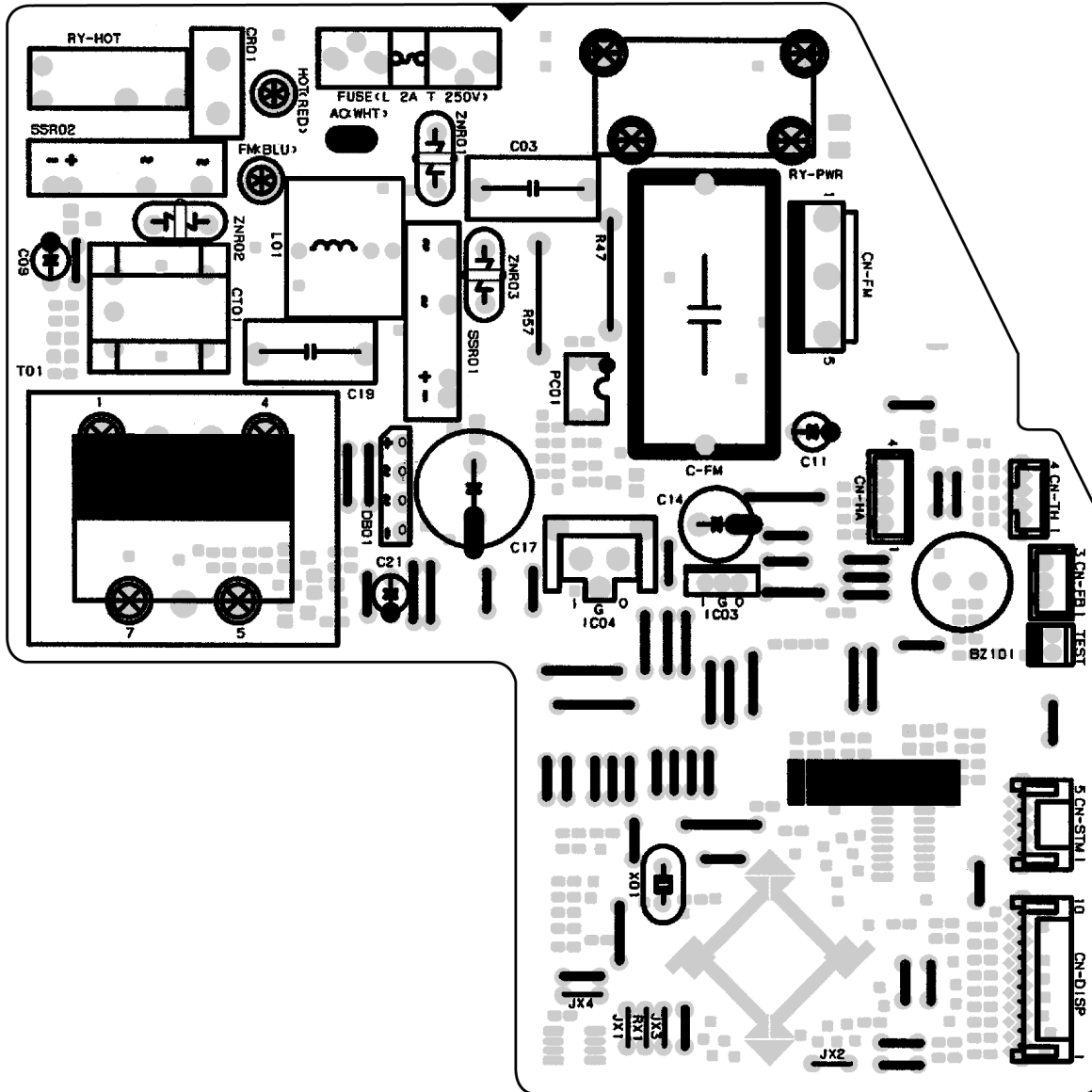

26.3. PRINT PATTERN INDOOR UNIT PRINTED CIRCUIT BOARD

BOTTOM VIEW

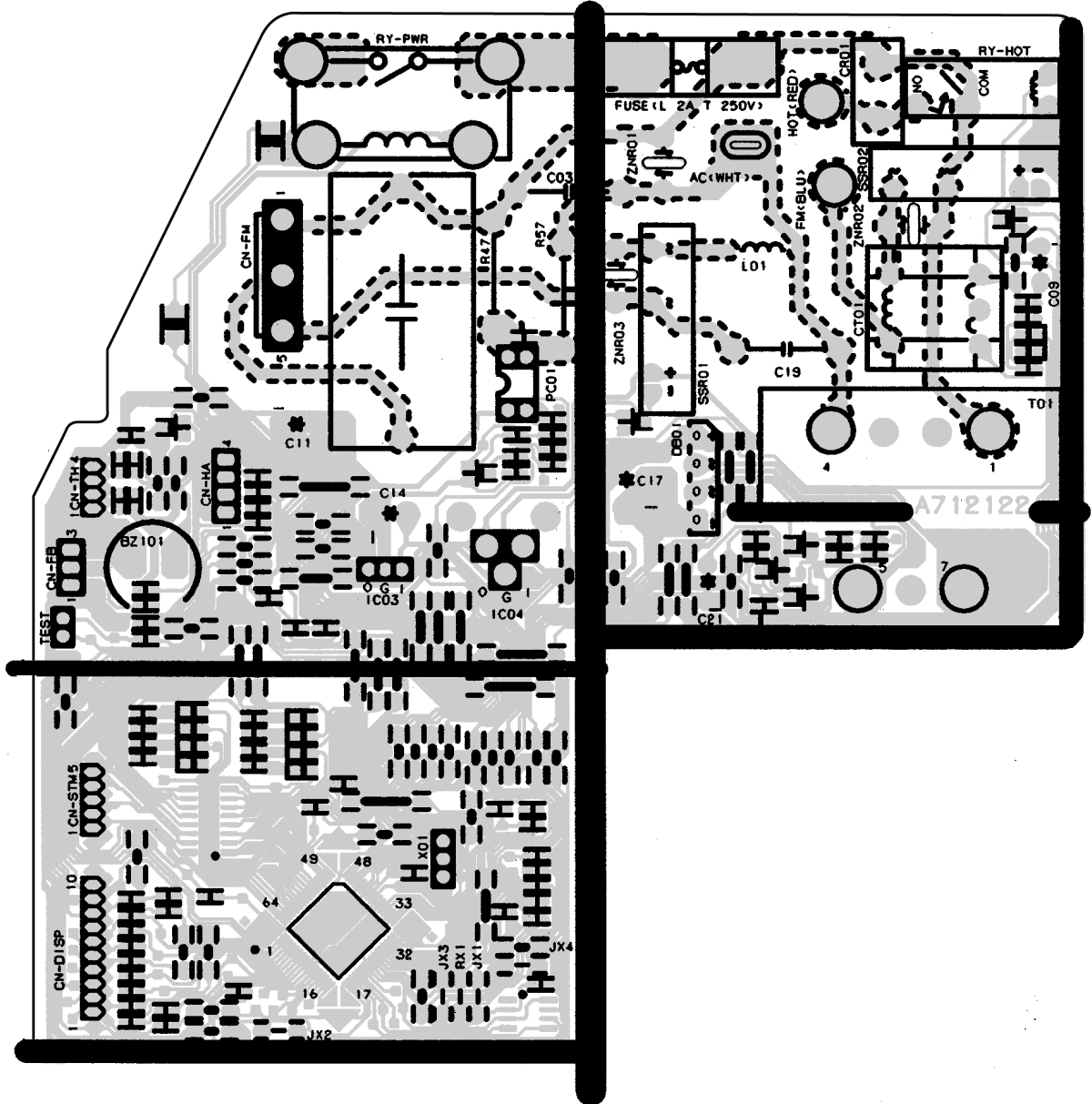

26.4. PRINT PATTERN OUTDOOR UNIT PRINTED CIRCUIT BOARD

CU-2C14BK / CU-3C20BK

