

# Service Manual

## Multi Air Conditioner

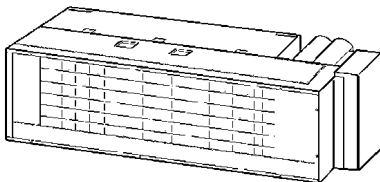

CS-ME7CB1P  
 CS-ME10CB1P  
 CS-ME12CB1P  
 CS-ME14CB1P  
 CS-ME10CD3P  
 CS-ME14CD3P

Please file and use this manual together with the service manual for Model No. CS-ME7CKPG, CS-ME10CKPG, CS-ME12CKPG, CS-ME14CKPG, CS-ME18CKPG, CU-2E15CBPG, CU-2E18CBPG, CU-3E23CBPG, CU-4E27CBPG, Order No. RAC0209005C2.

### ⚠ WARNING

This service information is designed for experienced repair technicians only and is not designed for use by the general public. It does not contain warnings or cautions to advise non-technical individuals of potential dangers in attempting to service a product. Products powered by electricity should be serviced or repaired only by experienced professional technicians. Any attempt to service or repair the product or products dealt with in this service information by anyone else could result in serious injury or death.

### ⚠ PRECAUTION OF LOW TEMPERATURE

In order to avoid frostbite, be assured of no refrigerant leakage during the installation or repairing of refrigeration circuit.

## CONTENTS

	Page		Page
<b>1 Features</b> .....	3	5.1. Cassette Type .....	8
<b>2 About Lead Free Solder (PbF)</b> .....	3	5.2. Grille .....	10
2.1. DISTINCTION OF PbF P.C. BOARD .....	3	5.3. Duct Type .....	11
2.2. CAUTION .....	3	<b>6 Refrigeration Cycle Diagram</b> .....	<b>12</b>
<b>3 Functions</b> .....	4	<b>7 Block Diagram</b> .....	<b>13</b>
3.1. REMOTE CONTROL .....	4	<b>8 Wiring Diagram</b> .....	<b>14</b>
3.2. INDOOR UNIT .....	5	8.1. Cassette Type (CS-	
<b>4 Product Specifications</b> .....	7	ME7CB1P/ME10CB1P/ME12CB1P/ME14CB1P) .....	14
<b>5 Dimensions</b> .....	8	8.2. Duct Type (CS-ME10CD3P/ME14CD3P) .....	15

# Panasonic

© 2003 Matsushita Electric Industrial Co., Ltd. All rights reserved. Unauthorized copying and distribution is a violation of law.

<b>9 Operation Details (Functions &amp; Protection)</b> .....	<b>16</b>	12.1. Cassette Type (Indoor Unit: CS-	
9.1. Simultaneous Operation Control .....	16	ME7CB1P/ME10CB1P/ME12CB1P/ME14CB1P) .....	53
9.2. Airflow Direction Control (Cassette Type only) .....	17	12.2. Duct Type (Indoor Unit: CS-ME10CD3P/ME14CD3P) .....	57
9.3. Indoor Fan Control .....	18	<b>13 Technical Data</b> .....	<b>59</b>
9.4. Drain Pump Control .....	20	13.1. OPERATION CHARACTERISTICS .....	59
9.5. Auto Restart Control .....	21	<b>14 Electronic Circuit Diagram</b> .....	<b>63</b>
9.6. Other Indoor Unit Operation Functions .....	22	14.1. REMOTE CONTROL .....	63
<b>10 Installation Instructions</b> .....	<b>30</b>	14.2. Cassette Type .....	64
10.1. Cassette Type .....	30	14.3. Duct Type .....	65
10.2. Duct Type .....	35	<b>15 Exploded View &amp; Replacement Parts List</b> .....	<b>66</b>
<b>11 Operating Instructions</b> .....	<b>41</b>	15.1. CS-ME7CB1P/ME10CB1P/ME12CB1P/ME14CB1P .....	66
<b>12 Disassembly of Parts</b> .....	<b>53</b>	15.2. CS-ME10CD3P/ME14CD3P .....	68

# 1 Features

**Product**

– A single OUTDOOR unit enables air conditioning of up to four separate rooms

OUT DOOR UNIT	CONNECTABLE INDOOR UNIT	Type	Wall					Cassette				Duct		Capacity range of connectable indoor units	Pipe length				
			2.2 kW	2.8 kW	3.2 kW	4.0 kW	5.0 kW	2.2 kW	2.8 kW	3.2 kW	4.0 kW	2.8 kW	4.0 kW		1-room maximum pipe length m	Allowable elevation m	Total allowable pipe length m	Total pipe length for maximum chargeless length m	Additional gas amount over chargeless length g/m
			CS-ME7CKPG	CS-ME10CKPG	CS-ME12CKPG	CS-ME14CKPG	CS-ME18CKPG	CS-ME7CB1P	CS-ME10CB1P	CS-ME12CB1P	CS-ME14CB1P	CS-ME10CD3P	CS-ME14CD3P						
CU-3E23CBPG	A	○	○	○	○	○	○	○	○	○	○	○	○	From 5.0 to 10.0 kW	25	15	50	30	20
	B	○	○	○	○	○	○	○	○	○	○	○	○						
	C	○	○	○	○	○	○	○	○	○	○	○	○						
CU-4E27CBPG	A	○	○	○	○	○	○	○	○	○	○	○	From 5.0 to 13.6 kW	25	15	70	40	20	
	B	○	○	○	○	○	○	○	○	○	○	○							
	C	○	○	○	○	○	○	○	○	○	○	○							
	D	○	○	○	○	○	○	○	○	○	○	○							

**Remarks:**

- At least two indoor units must be connected.
- The total nominal cooling capacity of indoor units that will be connected to outdoor unit must be within connectable capacity range of outdoor unit. (Shown in the above table)

Example: The below indoor units combination is not possible to connect CU-3E23CBPG. (Total nominal capacity of indoor unit is between 5.0kW and 10.0kW)

- Two CS-ME7CB1P only. (Total nominal cooling capacity is 4.4kW)
- Three CS-ME14CB1P only. (Total nominal cooling capacity is 12.0kW)

- Inverter controlled for High energy efficiency and optimal comfort
- **New refrigerant R410A** is used for protecting ozone layer
- Lead - free P.C. Board

**Serviceability**

- Self diagnosis
- Test Run at both Cooling and Heating rated frequency

**Built-in drain pump (Cassette and Duct type)**

- A drain pump is built in.
- The pipe can rise to 200 mm above the drain outlet.

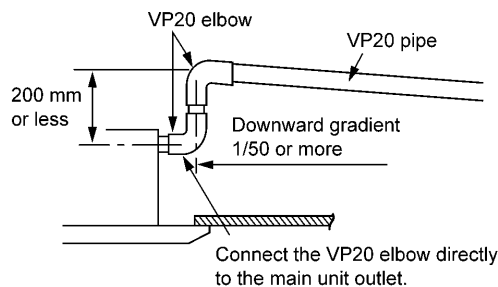

## 2 About Lead Free Solder (PbF)

### 2.1. DISTINCTION OF PbF P.C. BOARD

P.C. Boards (manufactured) using lead free solder will have a PbF stamp on the P.C. Board.

### 2.2. CAUTION

- Pb free solder has a higher melting point than standard solder; Typically the melting point is 50 - 70 °F (30 - 40 °C) higher. Please use a high temperature solder iron and set it to 700 ± 20 °F (370 ± 10 °C).
- Pb free solder will tend to splash when heated too high (about 1100 °F/ 600 °C).

If you must use Pb solder, please completely remove all of the Pb free solder on the pins or solder area before applying Pb solder. If this is not practical, be sure to heat the Pb free solder until it melts, before applying Pb solder.

# 3 Functions

## 3.1. REMOTE CONTROL

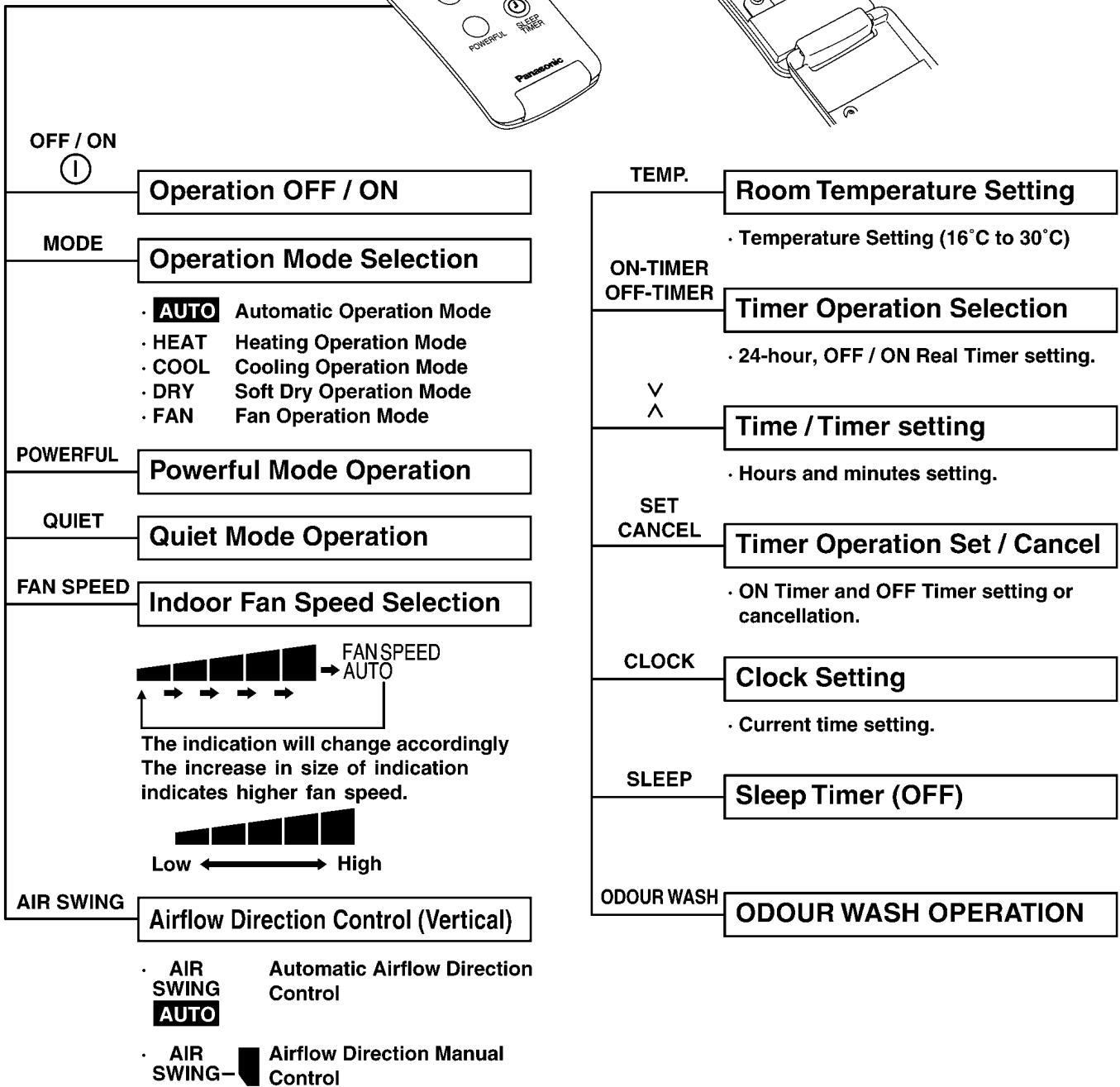
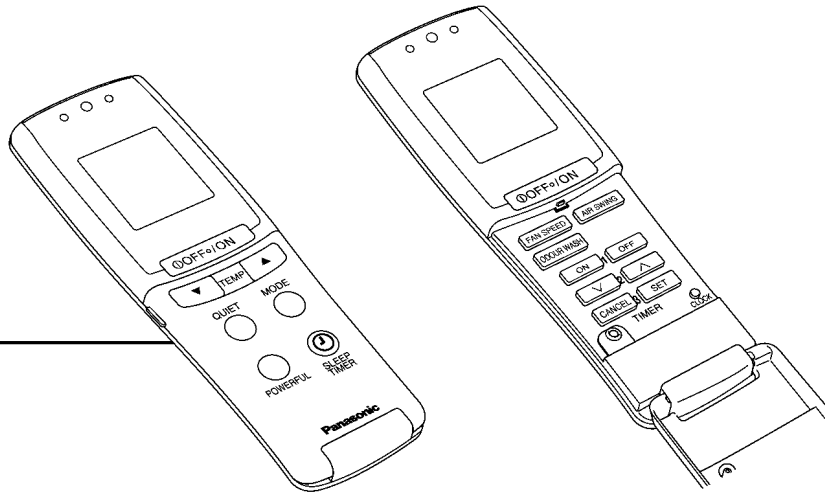

### 3.2. INDOOR UNIT

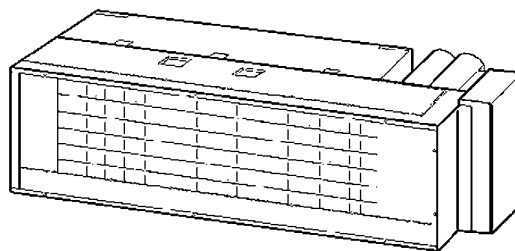
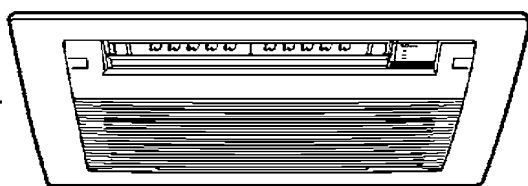

#### FOR ALL OPERATIONS

**Simultaneous Operation Control ※**

**Operation Indication Lamps**

- **POWER (GREEN)** - Lights up in operation, blinks in Automatic Operation judging and Hot Start Control.
- **TIMER (ORANGE)** - Lights up in timer setting. Blinks in Self Diagnosis Control.
- **ODOUR WASH (GREEN)** - Lights up ODOUR WASH Setting.

**AUTO SW ※**

- 5s **TEST RUN**
- 5s - 8s **FORCED OPERATION COOLING**
- 8s - 11s **FORCED OPERATION HEATING**
- 11s - 16s **VARIOUS SETTING 1**
  - REMOTE CONTROL A, B, C, D SETTING
- 16s - 21s **ODOUR WASHING**
- 21s - 26s **VARIOUS SETTING 2**
  - BEEP SOUND OFF

**Operation Mode**

- Automatic, Heating, Cooling, Dry and Fan Operation.

**Automatic Restart Control ※**

- Operation is restarted after power failure at previous setting mode.

**Sleep timer / Sleep Operation Mode**

**QUIET Mode**

**Timer Operation**

**ODOUR WASH Operation**

**Powerful Mode**

- For quick cooling or heating

**Indoor Fan Speed Control ※**

**Airflow Direction Control ※**

**Room Temperature Control**

**Temperature Shift**

**Self Diagnosis ※**

**HEATING OPERATION**

Anti-Cold Draft Control

Hot Start

Intake Air Temperature Control

**COOLING / SOFT DRY OPERATION**

Deodorizing Control

Anti-Fog Discharge Control

Anti-Dew Formation Control

Anti-Freezing Control

Drain Pump Control ※

**AUTOMATIC OPERATION**

**FAN OPERATION**

## 4 Product Specifications

Model			CS-ME7CB1P	CS-ME10CB1P	CS-ME12CB1P	CS-ME14CB1P	CS-ME10CD3P	CS-ME14CD3P
Item			Cassette Type				Duct Type	
Power Source			Outdoor power (single 230V 50Hz)					
Air Volume	Cooling	m <sup>3</sup> /min.	9.1		9.6	9.5	7.0	7.8
	Heating	m <sup>3</sup> /min.	9.8		10.2	9.8	8.7	
Noise Level	Cooling (Power)	dB(A) (dB)	Hi:40(53) Lo:32(45)		Hi:41(54) Lo:32(45)	Hi:43(56) Lo:32(45)	Hi:43(56) Lo:32(45)	Hi:45(58) Lo:32(45)
	Heating (Power)	dB(A) (dB)	Hi:42(55) Lo:32(45)		Hi:43(56) Lo:32(45)	Hi:44(57) Lo:34(47)	Hi:47(60) Lo:32(45)	Hi:47(60) Lo:35(48)
Moisture Removal		L/h	1.3	1.6	1.8	2.3	1.6	2.3
Refrigeration piping	Connection	Liquid	6.35 (1/4") Flare to the main unit					
		Gas	9.52 (3/8") Flare to the main unit					
		Type of pipe	CZ-3F					
Type of Indoor/Outdoor connecting cable		mm	4 x 1.5 mm <sup>2</sup> flexible cord, type designation 245 IEC 57 (H05RN-F)					
Drain opening		mm	VP20					
Dimensions		mm	Height 185 x Width 770 x Depth 360				Height 235 x Width 750 x Depth 370	
Net Weight		kg	9.8			10.5		16.5
Fan	Type		Cross-flow fan				Sirocco fan	
	Motor	Type	DC brushless motor (EHOCM24A4P25)				DC brushless motor (ARW31V8P30AC)	
		Output	W	4P 25W 40V A98258				8P 30W 280-340V A981071
Heat exchanger			Plate fin forced-draft					
Adjustments	Switches		Wireless remote control					
	Timer		Timer with ON and OFF times programmable					
	Temperature		Electronic thermostat					
Air filter			PP honeycomb				-	

### Remarks:

The specifications are differ from wall type indoor units when 2.8kW Duct type is connected to CU-2E15CBPG and CU-2E18CBPG.

	Indoor unit Combination	Outdoor unit	Power Input (kW)		Current (A)
				min. - max	
Cooling	22 + 28	CU-2E15CBPG	1.39	0.25 - 1.73	6.50
Heating			1.36	0.21 - 1.67	6.05
Cooling	22 + 28	CU-2E18CBPG	1.39	0.25 - 1.73	6.50
Heating			1.36	0.21 - 1.67	6.05
Cooling	28 + 28 (*)		1.56	0.25 - 1.73	7.25
Heating			1.47	0.21 - 1.74	6.50
Cooling	28 + 32		1.67	0.25 - 1.80	7.80
Heating			1.39	0.21 - 1.72	6.15

(\*) The combination 2.8kW Duct type X 2 and 2.8kW Duct type + 2.8kW Wall type are same value.

\* Specifications are subject to change without notice for further improvement.

### Rating Conditions

	Cooling	Heating
Inside air temperature	27°C DB / 19°C WB	20°C DB
Outside air temperature	35°C DB / 24°C WB	7°C DB / 6°C WB

# 5 Dimensions

## 5.1. Cassette Type

■ Cassette Type ( CS-ME7CB1P/ ME10CB1P/ ME12CB1P/ ME14CB1P )

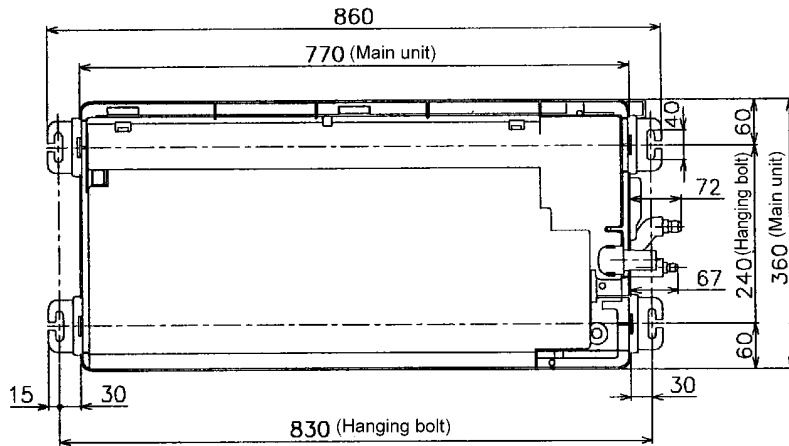

Top view

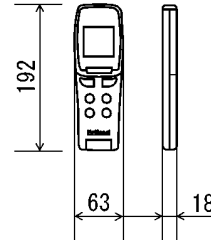

Remote control

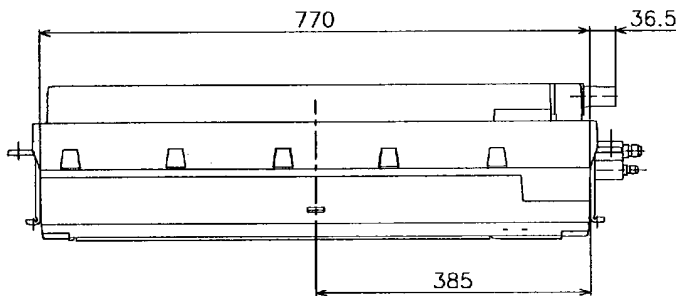

Front view

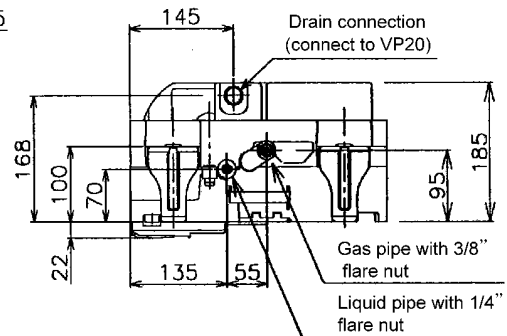

Right view

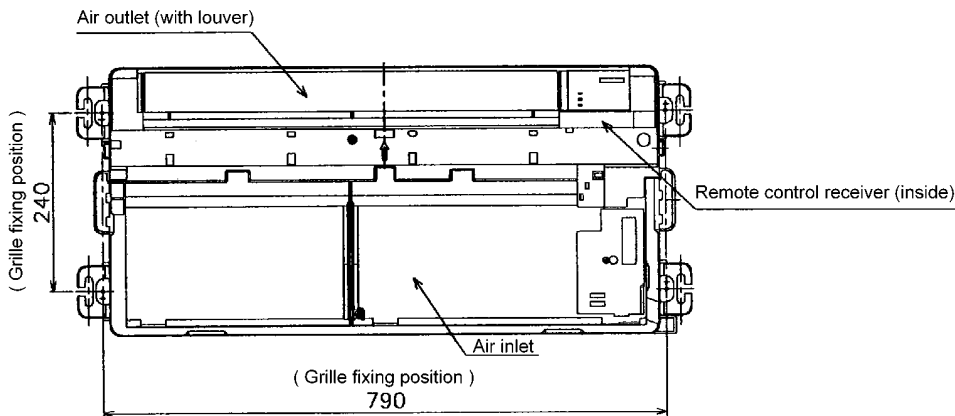

Bottom view

Units: mm



■ Cassette Type  
 ( CS-ME7CB1P/ ME10CB1P/ ME12CB1P/ ME14CB1P)

Installation dimensions  
 (Units: mm)

Grille	1070 × 460
Ceiling opening	1010 × 390
Hanging bolts	830 × 240
Main unit	H185 × W770 × D360
Ceiling clearance	190 or more
Drain rise	200 or less

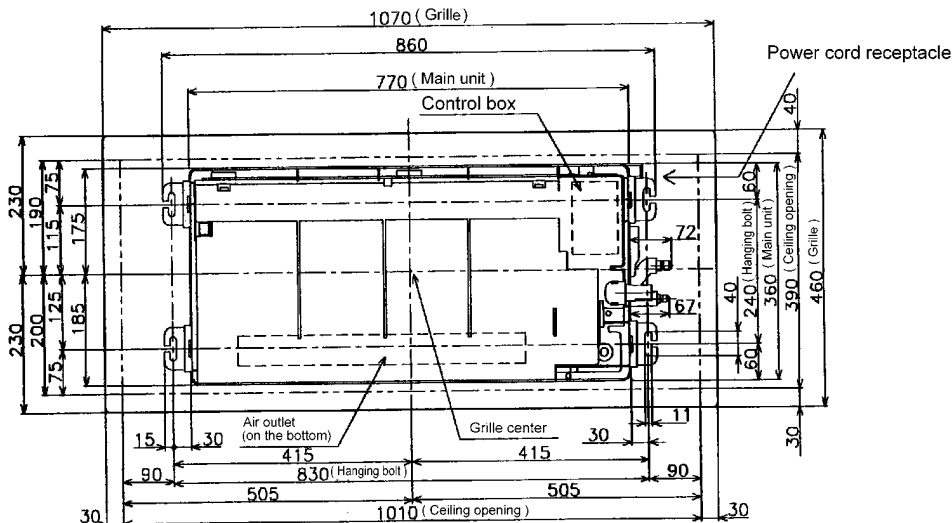
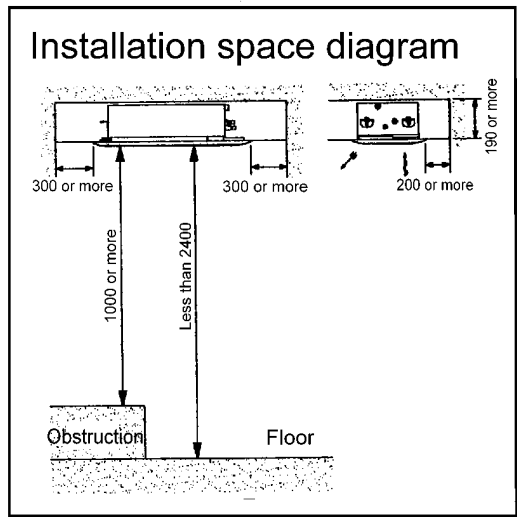

Top view

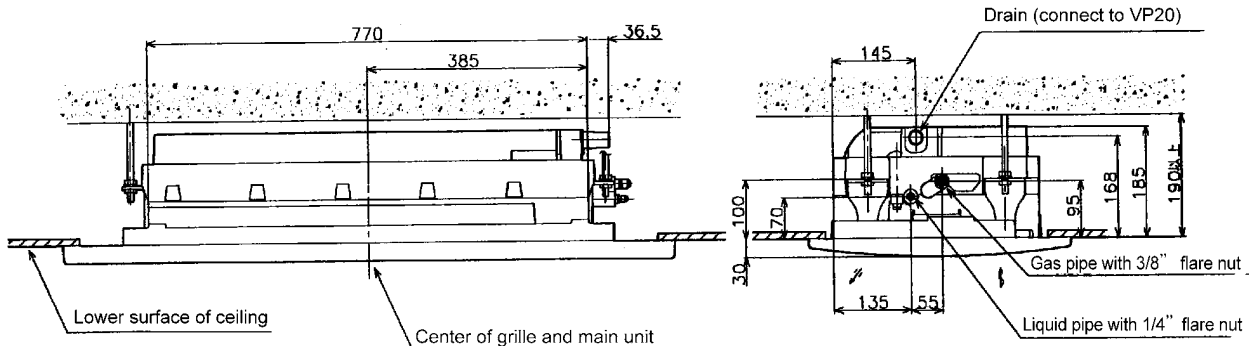

Front view

Right view

Units: mm

## 5.2. Grille

### ■ Grille ( CZ-BT20P )

Applicable model: CS-ME7CB1P / ME10CB1P / ME12CB1P / ME14CB1P

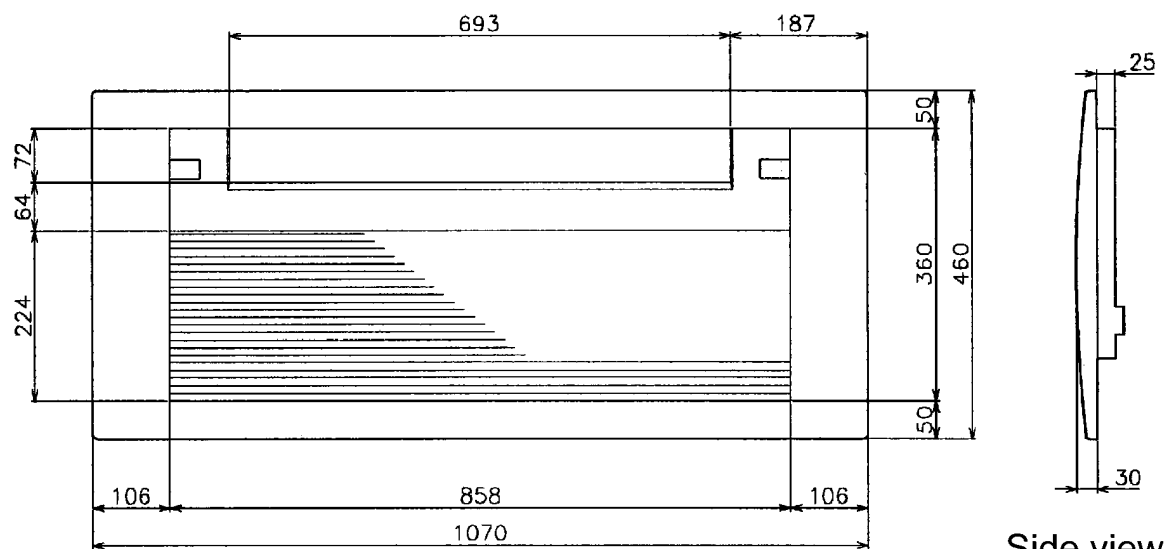

Top view

Side view

Units: mm

### 5.3. Duct Type

■ Duct Type ( CS-ME10CD3P / ME14CD3P )

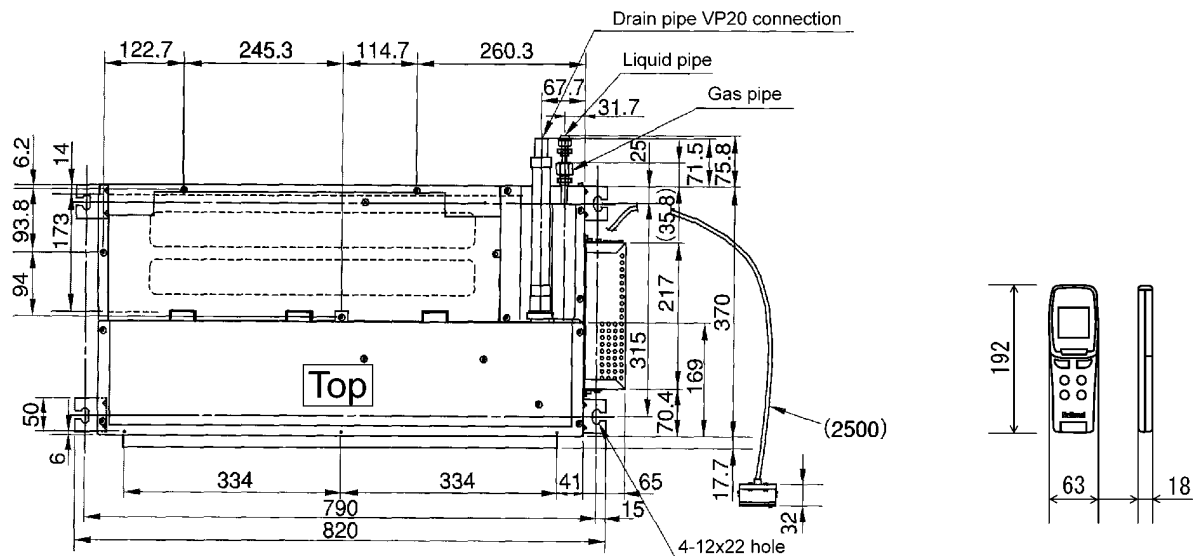

Top view

Remote control

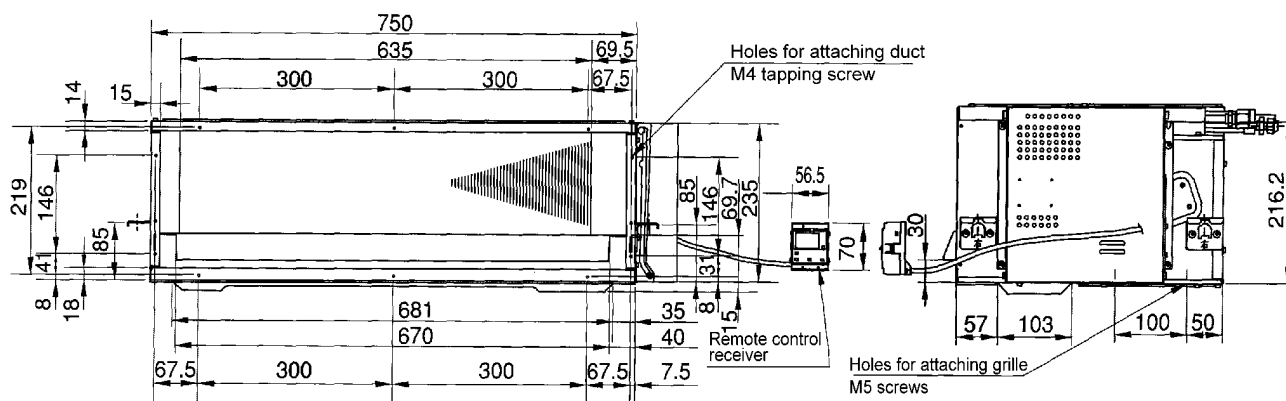

Front view

Side view

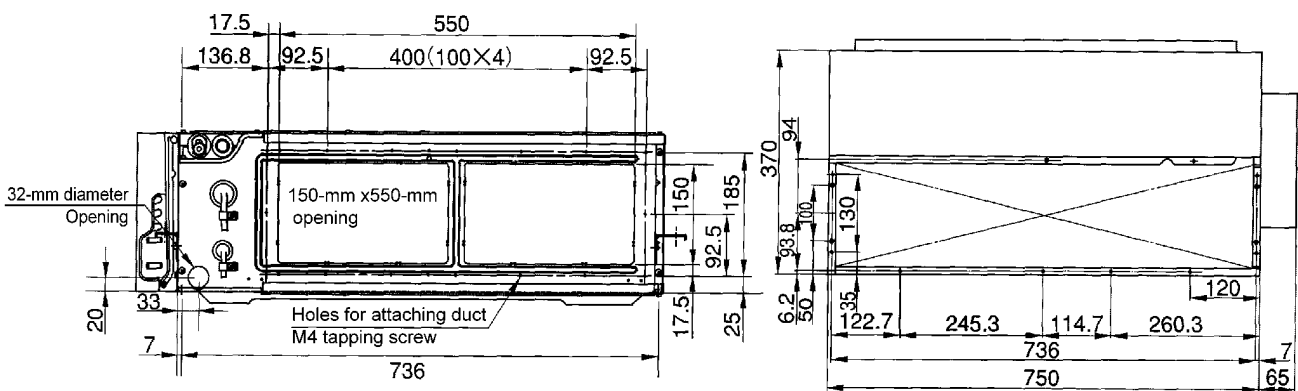

Back view

Detail of the air inlet on the bottom

Units: mm

# 6 Refrigeration Cycle Diagram

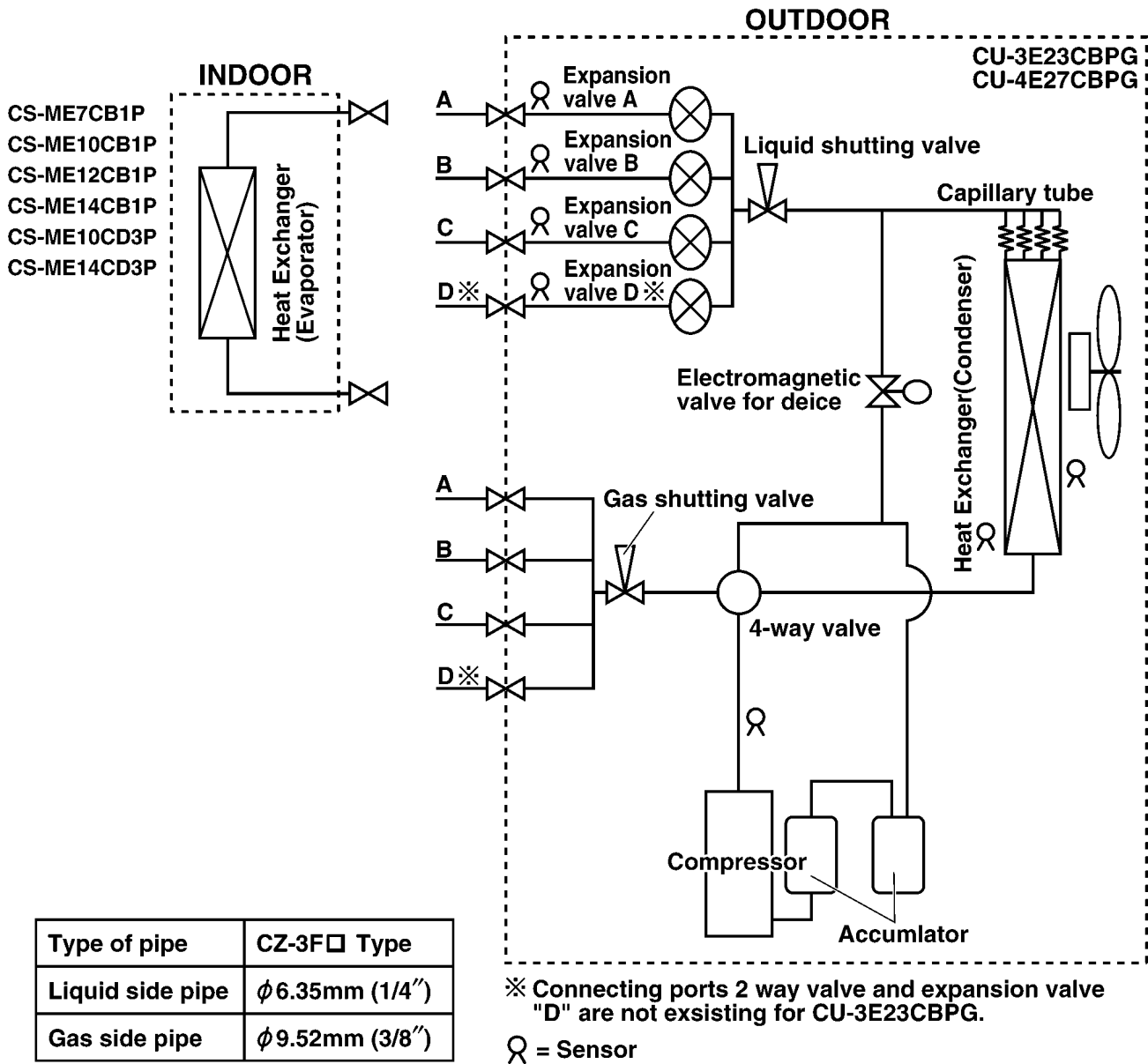

Type	Wall					Cassette				Duct		Capacity range of connectable indoor units	Pipe length				
	2.2 kW	2.8 kW	3.2 kW	4.0 kW	5.0 kW	2.2 kW	2.8 kW	3.2 kW	4.0 kW	2.8 kW	4.0 kW		1-room maximum pipe length	Allowable elevation	Total allowable pipe length	Total pipe length for maximum chargeless length	Additional gas amount over chargeless length
CONNECTABLE INDOOR UNIT	CS-ME7CKPG	CS-ME10CKPG	CS-ME12CKPG	CS-ME14CKPG	CS-ME18CKPG	CS-ME7CB1P	CS-ME10CB1P	CS-ME12CB1P	CS-ME14CB1P	CS-ME10CD3P	CS-ME14CD3P						
OUT DOOR UNIT	A	⊙	⊙	⊙	⊙	⊙	⊙	⊙	⊙	⊙	⊙	From 5.0 to 10.0 kW	25	15	50	30	20
	B	⊙	⊙	⊙	⊙	⊙	⊙	⊙	⊙	⊙	⊙						
	C	⊙	⊙	⊙	⊙	⊙	⊙	⊙	⊙	⊙	⊙						
ROOM	A	⊙	⊙	⊙	⊙	⊙	⊙	⊙	⊙	⊙	⊙	From 5.0 to 13.6 kW	25	15	70	40	20
	B	⊙	⊙	⊙	⊙	⊙	⊙	⊙	⊙	⊙	⊙						
	C	⊙	⊙	⊙	⊙	⊙	⊙	⊙	⊙	⊙	⊙						
	D	⊙	⊙	⊙	⊙	⊙	⊙	⊙	⊙	⊙	⊙						

# 7 Block Diagram

CS-ME7CB1P/ME10CB1P/ME12CB1P/ME14CB1P/ME10CD3P/ME14CD3P

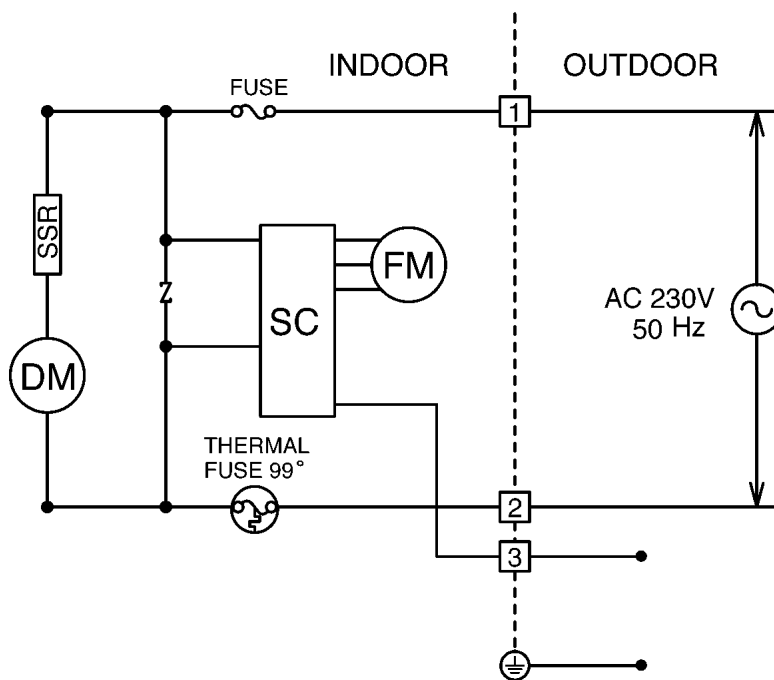

# 8 Wiring Diagram

## 8.1. Cassette Type (CS-ME7CB1P/ME10CB1P/ME12CB1P/ME14CB1P)

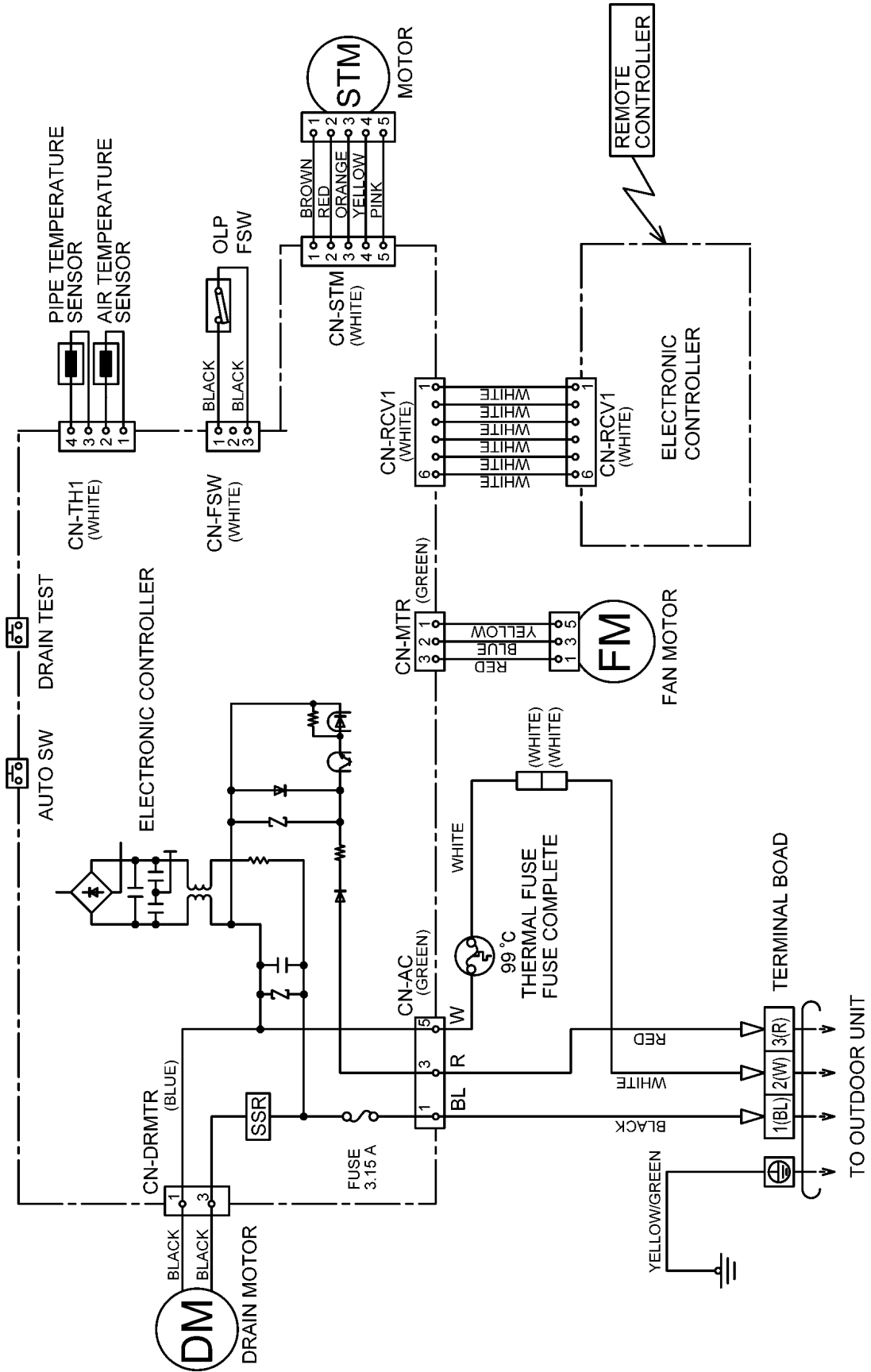

## 8.2. Duct Type (CS-ME10CD3P/ME14CD3P)

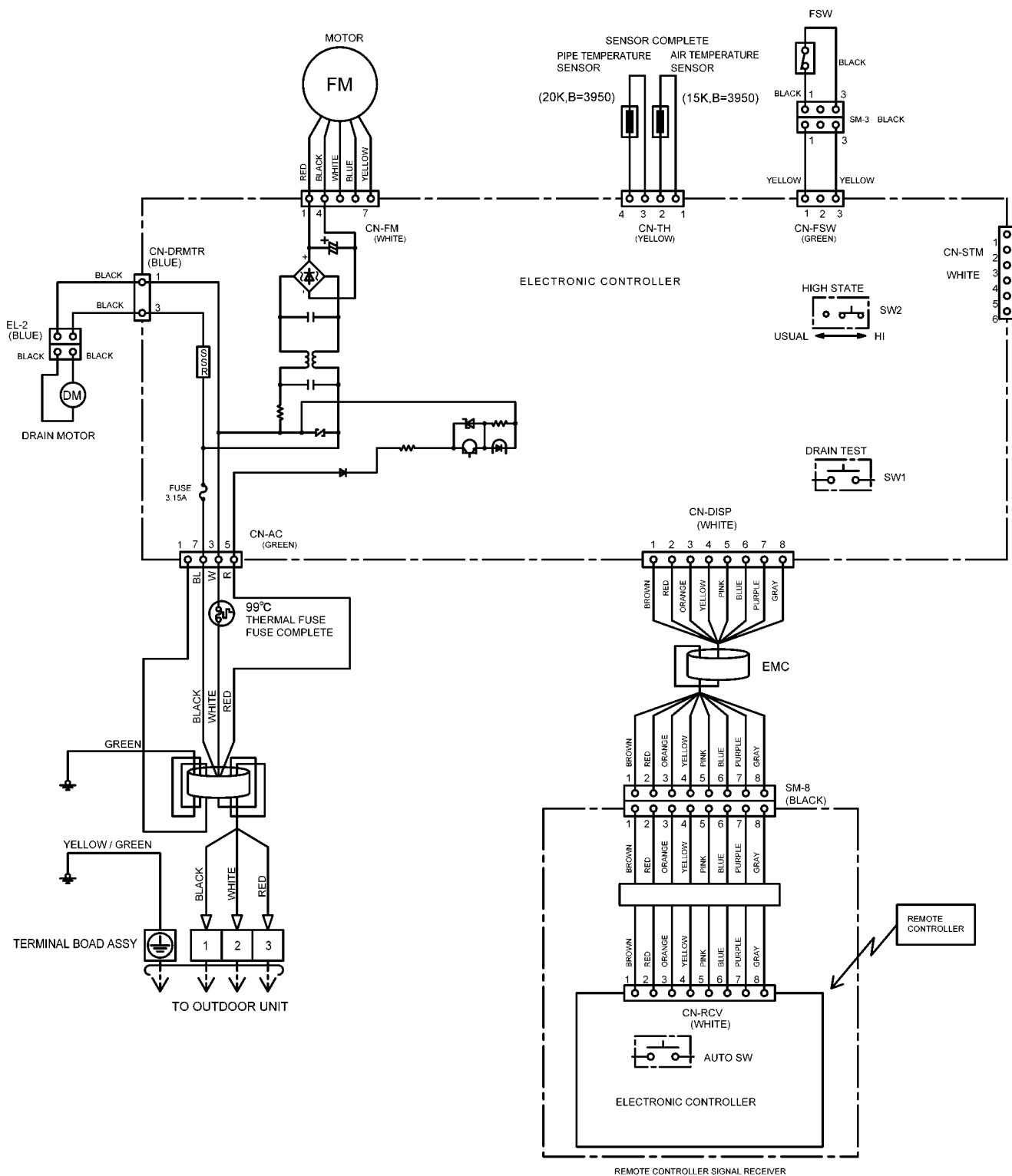

# 9 Operation Details (Functions & Protection)

## 9.1. Simultaneous Operation Control

1. **Operation modes which can be selected using the remote control unit:** Automatic, Cooling, Dry, Heating, Fan operation mode.

2. **Types of operations modes which can be performed simultaneously**

- Cooling operation and cooling, Dry or fan operation
- Heating operation and heating operation

3. **Types of operation modes which cannot be performed simultaneously**

- While a cooling operation is in progress, a heating operation cannot be performed by an indoor unit in another room.

In the room where the operation button for cooling was pressed first, the operation is continued. In the room where the operation button for heating was pressed afterward, the operation lamp of the indoor unit blinks, where the attempt is made to establish the heating operation. Its fan is stopped, and the air does not discharged.

- While a heating operation is in progress, a cooling operation cannot be performed by an indoor unit in another room.

In the room where the operation button for heating was pressed first, operation is continued. In the room where the operation button for cooling was pressed afterward, the operation lamp of the indoor unit blinks, where the attempt is made to establish the cooling operation. Its fan is stopped, and the air does not discharged.

4. **Operation mode priority control**

- The operation mode designated first by the indoor unit has priority.
- If the priority indoor unit stops operation or initiates the fan operation, the priority is transferred to other indoor units.

“Waiting” denotes the standby status in which the operation lamp LED blinks (ON for 2.5 sec. and OFF for 0.5 sec.), and the fan is stopped.

		B ROOM				Non Priority Unit (2nd. ON)			
		A ROOM		Cooling	Dry	Heating	Fan		
Priority Unit (1st. ON)	Cooling	C	C	C	D	C	Waiting	C	F
	Dry	D	C	D	D	D	Waiting	D	F
	Heating	H	Waiting	H	Waiting	H	H	H	Stop
	Fan *	F	C	F	D	Stop	H	F	F

\* In the fan mode, priority is transferred to a non-priority unit.

**Note**

- C: Cooling operation mode
- D: Dry operation mode
- H: Heating operation mode
- F: Fan operation mode



## 9.2. Airflow Direction Control (Cassette Type only)

The following shows how louver operation changes depending on the direction set with the AIR SWING button and other operating conditions.

### Cooling and Dry

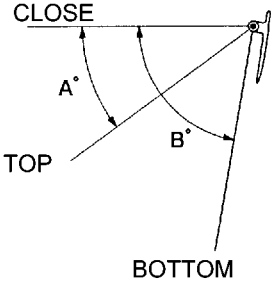
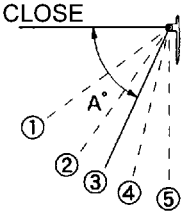
<p><b>(1) AUTO</b></p> <ul style="list-style-type: none"> <li>• When you set to AUTO on the remote control, the louver swings between the ranges shown in the below diagram.</li> <li>• The louver stops swinging if the indoor fan stops.</li> <li>• When stopped with the remote control, the louver moves to the CLOSE position.</li> </ul>	<p><b>(2) Airflow setting</b></p> <ul style="list-style-type: none"> <li>• You can choose one of five positions to stop the louver with the airflow button.</li> <li>• When stopped with the remote control, the louver moves to the CLOSE position.</li> </ul>																																																																
<table border="1" style="width: 100%; border-collapse: collapse;"> <tr> <th colspan="2">Operating conditions</th> <th>A</th> <th>B</th> </tr> <tr> <td rowspan="3">Cooling</td> <td>Normal</td> <td>36</td> <td>80</td> </tr> <tr> <td>Powerful</td> <td>36</td> <td>80</td> </tr> <tr> <td>Anti-dew formation</td> <td>45</td> <td>70</td> </tr> <tr> <td rowspan="3">Dry</td> <td>Normal</td> <td>36</td> <td>80</td> </tr> <tr> <td>Powerful</td> <td>36</td> <td>80</td> </tr> <tr> <td>Anti-dew formation</td> <td>45</td> <td>70</td> </tr> </table> 	Operating conditions		A	B	Cooling	Normal	36	80	Powerful	36	80	Anti-dew formation	45	70	Dry	Normal	36	80	Powerful	36	80	Anti-dew formation	45	70	<table border="1" style="width: 100%; border-collapse: collapse;"> <tr> <th colspan="2">Operating conditions</th> <th colspan="5">A</th> </tr> <tr> <td colspan="2"></td> <th>①</th> <th>②</th> <th>③</th> <th>④</th> <th>⑤</th> </tr> <tr> <td rowspan="3">Cooling</td> <td>Normal</td> <td>36</td> <td>50</td> <td>63</td> <td>77</td> <td>90</td> </tr> <tr> <td>Powerful</td> <td>36</td> <td>50</td> <td>63</td> <td>77</td> <td>90</td> </tr> <tr> <td>Anti-dew formation</td> <td>45</td> <td>51</td> <td>58</td> <td>64</td> <td>70</td> </tr> <tr> <td>Dry</td> <td></td> <td>36</td> <td>50</td> <td>63</td> <td>77</td> <td>90</td> </tr> </table> 	Operating conditions		A							①	②	③	④	⑤	Cooling	Normal	36	50	63	77	90	Powerful	36	50	63	77	90	Anti-dew formation	45	51	58	64	70	Dry		36	50	63	77	90
Operating conditions		A	B																																																														
Cooling	Normal	36	80																																																														
	Powerful	36	80																																																														
	Anti-dew formation	45	70																																																														
Dry	Normal	36	80																																																														
	Powerful	36	80																																																														
	Anti-dew formation	45	70																																																														
Operating conditions		A																																																															
		①	②	③	④	⑤																																																											
Cooling	Normal	36	50	63	77	90																																																											
	Powerful	36	50	63	77	90																																																											
	Anti-dew formation	45	51	58	64	70																																																											
Dry		36	50	63	77	90																																																											

### Heating

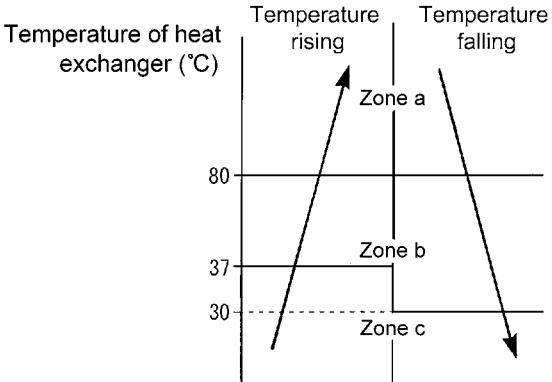
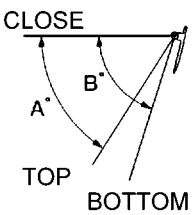
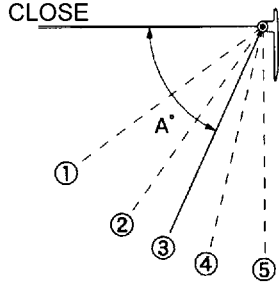
<p><b>(1) AUTO</b></p> <ul style="list-style-type: none"> <li>• When you set to AUTO on the remote control, the louver swings between the ranges shown in the below diagram to prevent cold drafts and improve heating.</li> <li>• When stopped with the remote control, the louver moves to the CLOSE position.</li> </ul>	<p><b>(2) Airflow setting</b></p> <ul style="list-style-type: none"> <li>• You can choose one of five positions to stop the louver with the airflow button.</li> <li>• When stopped with the remote control, the louver moves to the CLOSE position.</li> </ul>																																																
 <table border="1" style="width: 100%; border-collapse: collapse;"> <tr> <th>Operating conditions</th> <th>A</th> <th>B</th> <th>Movement</th> </tr> <tr> <td>Zone a</td> <td></td> <td>90</td> <td>Fixed</td> </tr> <tr> <td rowspan="2">Zone b</td> <td>Normal</td> <td>57</td> <td>76</td> <td rowspan="2">Swinging</td> </tr> <tr> <td>Powerful</td> <td>57</td> <td>76</td> </tr> <tr> <td>Zone c</td> <td></td> <td>34</td> <td>Fixed</td> </tr> </table> 	Operating conditions	A	B	Movement	Zone a		90	Fixed	Zone b	Normal	57	76	Swinging	Powerful	57	76	Zone c		34	Fixed	<table border="1" style="width: 100%; border-collapse: collapse;"> <tr> <th colspan="2">Operating conditions</th> <th colspan="5">A</th> </tr> <tr> <td colspan="2"></td> <th>①</th> <th>②</th> <th>③</th> <th>④</th> <th>⑤</th> </tr> <tr> <td colspan="2">Normal</td> <td>34</td> <td>48</td> <td>62</td> <td>76</td> <td>90</td> </tr> <tr> <td colspan="2">Powerful</td> <td>34</td> <td>48</td> <td>62</td> <td>76</td> <td>90</td> </tr> </table> 	Operating conditions		A							①	②	③	④	⑤	Normal		34	48	62	76	90	Powerful		34	48	62	76	90
Operating conditions	A	B	Movement																																														
Zone a		90	Fixed																																														
Zone b	Normal	57	76	Swinging																																													
	Powerful	57	76																																														
Zone c		34	Fixed																																														
Operating conditions		A																																															
		①	②	③	④	⑤																																											
Normal		34	48	62	76	90																																											
Powerful		34	48	62	76	90																																											

- The louver stops at the CLOSE position when the power switch or breaker is ON.
- The louver stops at their current position when the power switch or breaker is OFF.
- Move the horizontal airflow direction control louver manually.

### 9.3. Indoor Fan Control

- The following shows how fan speed changes depending on the setting made with the FAN SPEED button and other operating conditions.
- Actual fan speed may differ from that you set with remote control.

《 CS-ME7CB1P/CS-ME10CB1P 》

Voltage supply to fan motor DC(V)		Stop	~	14.2	~	15.2	~	16.2	~	17.6	~	19.3	~	20.5	~	23.0	~	25.0	~	27.0	~	30.0	~	32.0	~	35.0	Remarks	
Cooling	Manual							SSLo		SLo		Lo-		Low	Me-	Me	Me+	Hi								Remote control settings		
	Auto	○						○						※1	※2	24.5	25.5									※1	When difference between intake air temperature and internal set temperature is +0.5°C and below.	
	Powerful	○												※1	※2	28.5	29.0										※2	When difference between intake air temperature and internal set temperature is +1.5°C and below.
	Quiet	○										※1	※2	23.0	23.5													
Dry	Manual	◎						SSLo		SLo		Lo-		Low	Me-	Me	Me+	Hi									※2	When difference between intake air temperature and internal set temperature is +1.5°C and below.
	Auto	○						○						※1	※2	24.5	25.5											
Voltage supply to fan motor DC(V)		Stop	~	14.2	~	15.2	~	20.5	~	~	~	22.6	~	~	~	25.0	~	28.0	~	30.5	~	33.0	~	35.0	~	36.0		
Heating	Manual			SSLo		SLo						Low		Me-	Me	Me+	Hi											
	Auto	○		○		○						◎	◎	◎	◎	◎	◎	◎	◎	◎	◎	◎	◎	◎	◎	◎	◎	When difference between intake air temperature and internal set temperature is +1.5°C and below.
	Powerful	○										◎	◎	◎	◎	◎	◎	◎	◎	◎	◎	◎	◎	◎	◎	◎	◎	When difference between intake air temperature and internal set temperature is +1.5°C and above.
	Quiet	○										◎	◎	◎	◎	◎	◎	◎	◎	◎	◎	◎	◎	◎	◎	◎	◎	

◎ fan speed is set automatically      \* 1. ○ in Cooling indicates that fan speed and deodorizing are controlled together.  
 \* 2. ○ in Heating indicates that fan speed, hot start and anti-cold draft are controlled together.

《 CS-ME12CB1P 》

Voltage supply to fan motor DC(V)		Stop	~	15.2	~	16.2	~	17.6	~	19.3	~	21.5	~	24.0	~	26.5	~	29.0	~	31.5	~	33.5	~	38.0	Remarks			
Cooling	Manual					SSLo		SLo		Lo-		Low	Me-	Me	Me+	Hi										Remote control settings		
	Auto	○				○						◎	◎	◎	◎	◎	◎	◎	◎	◎	◎	◎	◎	◎	◎	◎	※1	When difference between intake air temperature and internal set temperature is +0.5°C and below.
	Powerful	○										◎	◎	◎	◎	◎	◎	◎	◎	◎	◎	◎	◎	◎	◎	◎	※2	When difference between intake air temperature and internal set temperature is +1.5°C and below.
	Quiet	○										◎	◎	◎	◎	◎	◎	◎	◎	◎	◎	◎	◎	◎	◎	◎		
Dry	Manual	◎				SSLo		SLo		Lo-		Low	Me-	Me	Me+	Hi											※2	When difference between intake air temperature and internal set temperature is +1.5°C and below.
	Auto	○						○				◎	◎	◎	◎	◎	◎	◎	◎	◎	◎	◎	◎	◎	◎	◎		
Voltage supply to fan motor DC(V)		Stop	~	15.2	~	16.2	~	19.3	~	22.6	~	~	~	26.0	~	29.0	~	32.0	~	35.0	~	38.0	~	38.5				
Heating	Manual			SSLo		SLo		Lo-				Low		Me-	Me	Me+	Hi											
	Auto	○		○		○						◎	◎	◎	◎	◎	◎	◎	◎	◎	◎	◎	◎	◎	◎	◎	◎	When difference between intake air temperature and internal set temperature is +1.5°C and above.
	Powerful	○										◎	◎	◎	◎	◎	◎	◎	◎	◎	◎	◎	◎	◎	◎	◎	◎	
	Quiet	○										◎	◎	◎	◎	◎	◎	◎	◎	◎	◎	◎	◎	◎	◎	◎	◎	

◎ fan speed is set automatically      \* 1. ○ in Cooling indicates that fan speed and deodorizing are controlled together.  
 \* 2. ○ in Heating indicates that fan speed, hot start and anti-cold draft are controlled together.

《 CS-ME14CB1P 》

Voltage supply to fan motor DC(V)		Stop	~	15.2	~	16.2	~	17.6	~	19.3	~	21.5	~	25.0	~	28.0	~	31.0	~	34.5	~	36.0	~	38.0	Remarks			
Cooling	Manual					SSLo		SLo		Lo-		Low	Me-	Me	Me+	Hi										Remote control settings		
	Auto	○				○						◎	◎	◎	◎	◎	◎	◎	◎	◎	◎	◎	◎	◎	◎	◎	※1	When difference between intake air temperature and internal set temperature is +0.5°C and below.
	Powerful	○										◎	◎	◎	◎	◎	◎	◎	◎	◎	◎	◎	◎	◎	◎	◎	※2	When difference between intake air temperature and internal set temperature is +1.5°C and below.
	Quiet	○										◎	◎	◎	◎	◎	◎	◎	◎	◎	◎	◎	◎	◎	◎	◎		
Dry	Manual	◎				SSLo		SLo		Lo-		Low	Me-	Me	Me+	Hi											※2	When difference between intake air temperature and internal set temperature is +1.5°C and below.
	Auto	○						○				◎	◎	◎	◎	◎	◎	◎	◎	◎	◎	◎	◎	◎	◎	◎		
Voltage supply to fan motor DC(V)		Stop	~	15.2	~	16.2	~	22.6	~	25.0	~	~	~	28.0	~	31.0	~	34.0	~	37.0	~	38.0	~	38.5				
Heating	Manual			SSLo		SLo		Lo-				Low		Me-	Me	Me+	Hi											
	Auto	○		○		○						◎	◎	◎	◎	◎	◎	◎	◎	◎	◎	◎	◎	◎	◎	◎	◎	When difference between intake air temperature and internal set temperature is +1.5°C and above.
	Powerful	○										◎	◎	◎	◎	◎	◎	◎	◎	◎	◎	◎	◎	◎	◎	◎	◎	
	Quiet	○										◎	◎	◎	◎	◎	◎	◎	◎	◎	◎	◎	◎	◎	◎	◎	◎	

◎ fan speed is set automatically      \* 1. ○ in Cooling indicates that fan speed and deodorizing are controlled together.  
 \* 2. ○ in Heating indicates that fan speed, hot start and anti-cold draft are controlled together.

《 CS-ME10CD3P 》

Voltage supply to fan motor DC(V)		Stop	~	3.13	~	3.37	~	3.49	~	3.72	~	3.91	~	3.98	~	4.10	~	4.27	~	4.50	~	4.58	~	4.79	~	5.03	Remarks
Cooling	Manual					SSL <sub>Lo</sub> S <sub>Lo</sub>		Lo-		Low		Me-				Me		Me+		Hi		SHi		PSHi		Remote control settings ※1 When difference between intake air temperature and internal set temperature is +0.5°C and below. ※2 When difference between intake air temperature and internal set temperature is +1.5°C and below.	
	Auto	○				○				⊗※1		⊗※2				⊗1040	~	⊗1080									
	Powerful	○														⊗※1	⊗※2	⊗1120	~	⊗1160							
	Quiet	○							⊗※1	⊗※2	⊗960	~	⊗1000														
Dry	Manual	⊙				SSL <sub>Lo</sub> S <sub>Lo</sub>		Lo-		Low		Me-				Me		Me+		Hi		SHi		PSHi		When difference between intake air temperature and internal set temperature is +1.5°C and below.	
	Auto	○				○				⊗※1		⊗※2				⊗1040	~	⊗1080									
Voltage supply to fan motor DC(V)		Stop	~	3.13	~	3.37	~	3.49	~	3.72	~	3.91	~	3.98	~	4.10	~	4.27	~	4.55	~	4.84	~	4.98	~	5.03	Remote control settings ※1 When difference between intake air temperature and internal set temperature is +0.5°C and below. ※2 When difference between intake air temperature and internal set temperature is +1.5°C and above.
Heating	Manual					SSL <sub>Lo</sub> S <sub>Lo</sub>		Lo-		Low		Me-				Me		Me+		Hi		SSH <sub>i</sub>		PSHi			
	Auto	○				○		⊙	⊙	⊙	⊙	⊙	⊙	⊙	⊙	⊙	⊙	⊙	⊙	⊙	⊙	⊙	⊙	⊙	⊙		
	Powerful	○																									
	Quiet	○				⊙	⊙	⊙	⊙	⊙	⊙	⊙	⊙	⊙	⊙	⊙	⊙	⊙	⊙	⊙	⊙	⊙	⊙	⊙	⊙	⊙	

⊙ fan speed is set automatically      \* 1. ○ in Cooling indicates that fan speed and deodorizing are controlled together.  
 \* 2. ○ in Heating indicates that fan speed, hot start and anti-cold draft are controlled together.

《 CS-ME14CD3P 》

Voltage supply to fan motor DC(V)		Stop	~	3.13	~	3.37	~	3.49	~	3.72	~	3.91	~	4.13	~	4.20	~	4.36	~	4.67	~	4.74	~	4.79	~	5.03	Remarks
Cooling	Manual					SSL <sub>Lo</sub> S <sub>Lo</sub>		Lo-		Low		Me-				Me		Me+		Hi		SHi		PSHi		Remote control settings ※1 When difference between intake air temperature and internal set temperature is +0.5°C and below. ※2 When difference between intake air temperature and internal set temperature is +1.5°C and below.	
	Auto	○				○				⊗※1		⊗※2				⊗1040	~	⊗1080									
	Powerful	○														⊗※1	⊗※2	⊗1120	~	⊗1160							
	Quiet	○							⊗※1	⊗※2	⊗960	~	⊗1000														
Dry	Manual	⊙				SSL <sub>Lo</sub> S <sub>Lo</sub>		Lo-		Low		Me-				Me		Me+		Hi		SHi		PSHi		When difference between intake air temperature and internal set temperature is +1.5°C and below.	
	Auto	○				○				⊗※1		⊗※2				⊗1040	~	⊗1080									
Voltage supply to fan motor DC(V)		Stop	~	3.13	~	3.37	~	3.49	~	3.72	~	3.91	~	4.13	~	4.20	~	4.36	~	4.60	~	4.84	~	4.98	~	5.03	Remote control settings ※1 When difference between intake air temperature and internal set temperature is +0.5°C and below. ※2 When difference between intake air temperature and internal set temperature is +1.5°C and above.
Heating	Manual					SSL <sub>Lo</sub> S <sub>Lo</sub>		Lo-		Low		Me-				Me		Me+		Hi		SSH <sub>i</sub>		PSHi			
	Auto	○				○				⊙	⊙	⊙	⊙	⊙	⊙	⊙	⊙	⊙	⊙	⊙	⊙	⊙	⊙	⊙	⊙		
	Powerful	○																									
	Quiet	○							⊙	⊙	⊙	⊙	⊙	⊙	⊙	⊙	⊙	⊙	⊙	⊙	⊙	⊙	⊙	⊙	⊙	⊙	

⊙ fan speed is set automatically      \* 1. ○ in Cooling indicates that fan speed and deodorizing are controlled together.  
 \* 2. ○ in Heating indicates that fan speed, hot start and anti-cold draft are controlled together.

## 9.4. Drain Pump Control

### Basic operation

- The drain pump starts 50 seconds after the indoor unit starts or the thermostat comes on (i.e., 10 seconds after the fan motor starts).

The drain pump stops 30 seconds after the indoor unit stops or the thermostat turns off.

- The drain pump repeats a cycle of on for 30 seconds then off for between 50 and 90 seconds as long as the unit is operating. Operation while the unit is off is determined by the difference between the temperature setting and the room temperature.

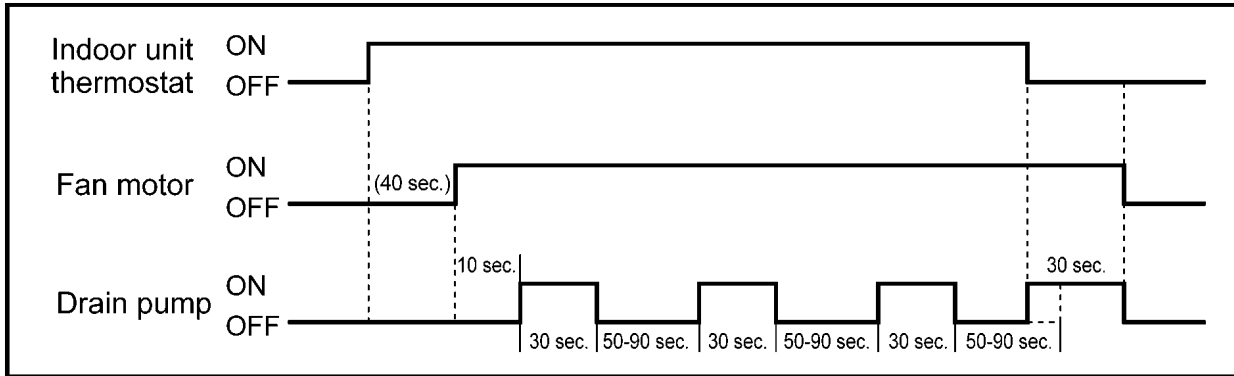

### Float switch operation

- When the float switch turns on for 10 seconds continuously, the thermostat of the indoor unit turns off and the drain pump operates continuously.
- When the float switch stays on for 150 seconds continuously, the drain pump and indoor unit stop and the timer lamp flashes indicating an H21 error.

## 9.5. Auto Restart Control

· if there is a power failure, operation will automatically be restarted when the power is resumed. It will start with the previous operation mode and airflow direction. (Time Delay Safety Control is valid)

### 1. Control start conditions

<1> The 24-hour timer must not be set.

<2> The sleep timer must not be set.

Auto restart control is not available when timer or sleep mode is set.

### 2. Description of control

<1> In the case of manual operation, the operation mode, temperature setting, fan speed and airflow direction before the power is turned off are restored.

<2> In the case of automatic operation, after the power is restored operation starts with the determination of the mode.

<3> While the air conditioner odour clear timer has been set, the setting is cancelled, and operation is transferred to the mode before the power is turned off.

<4> While the air conditioner odour clear operation (with timer / without timer setting) are being performed, both of these operations are completed, and operation is transferred to the operation mode prior to these operations.

Example: When the power is turned off during an outdoor unit cooling operation

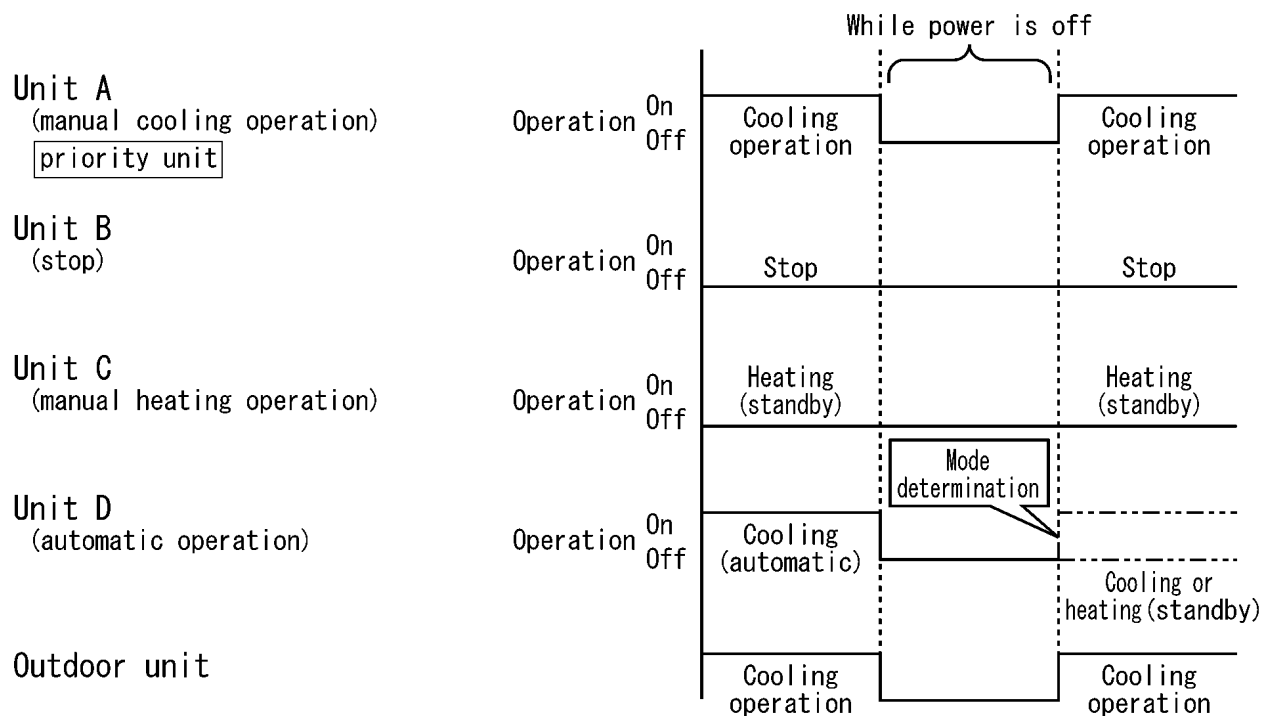

## 9.6. Other Indoor Unit Operation Functions

### 9.6.1. Auto button

Proceed with operation when the air conditioner is stopped.

(When the auto button is pressed during operation, the air conditioner is stopped.)

#### Cassette Type

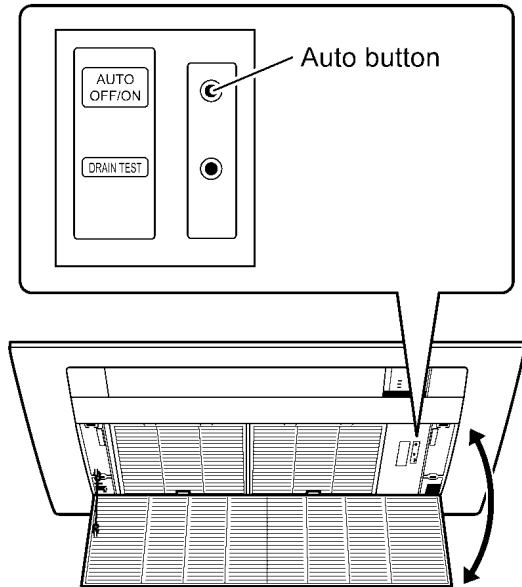

#### Duct Type

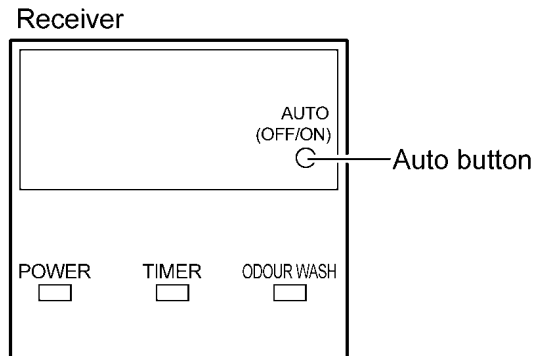

#### 1. Emergency operation

Press the auto button and release it within 5 seconds to perform emergency operation.

Under normal condition (failure is not occurred) automatic operation is performed. In the event of a failure that still enables operation to be performed, emergency operation is performed.

#### 2. Forced cooling operation

Press the auto button about 5-8 seconds (1 beep sound) to perform the forced cooling operation.

**The air conditioner does not operate for 2 minutes if the room temperature is low (intake temperature below 16 °C) so just wait. The forced operation is performed after the 2 minutes have elapsed.**

#### 3. Forced heating operation

Press the auto button about 8-11 seconds (2 beeps sound) to perform the forced heating operation.

#### 4. Setting modes (Remote control transmission code, current switching mode)

The remote control transmission code selection mode is established by pressing the AUTO button about 11-16 seconds (3 beeps sound).

Remote control transmission code selection ... remote control unit no.A (beep) ↔ remote control unit no.B (extended beep)  
(Auto button operation)

## CHANGING THE REMOTE CONTROL TRANSMISSION CODE

- When installing two air conditioners in one room, each air conditioner can be synchronized to the remote control. In order to operate separately, open the rear cover of one of the remote control and set to "B".

### Set "B" on the remote control.

This can be achieved by cutting the jumper wire of the remote control with a cutter.

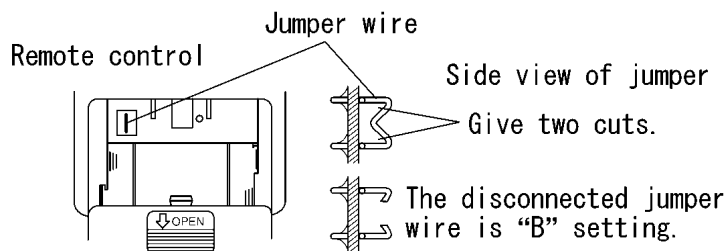

### Setting the air conditioner unit to "B"

- Press the "AUTO" button for about 11 to 15 seconds. When you hear three short beeps, release the button. Note: you will hear one beep in about 5 seconds, and then two beeps in about 8 seconds.
- Press again the "AUTO" button within 60 seconds. Every press the "AUTO" button, you pressing the "AUTO" button, which achieves "B" setting. If you stop pressing the "AUTO" button midway at the short beep, this will achieve "A" setting.
- After 60 seconds or longer of the above setting, use the "B" set remote control to confirm successful operation.
- Set, A, B, C or D transmission code at remote control. (Fig.1)

Remote Control  
Transmission Code Change (Fig.1)

Setting	J-A	J-B	Remarks
A	ON	ON	At product delivery
B	OFF	ON	
C	ON	OFF	
D	OFF	OFF	

ON: Connected

OFF: Disconnected

\* J-B is locating on the PC Board.

### 5. Odour clear setting mode

The odour clear inhibit mode is established by pressing the AUTO button 16-21 seconds (4 beeps sound).

Odour clear (beep)  $\leftrightarrow$  Odour clear inhibit (long beep sound)  
(Auto button operation)

### 6. Individual setting mode

The H14 error detection selection mode is established by pressing the auto button about for 21 seconds (5 beeps sound). Now remove the remote control unit's battery cover, and short the "SET" terminals to establish the beep sound mute mode.

H14 error detection ... error detection (1 beep)  $\leftrightarrow$  no error detection (long beep)  
(Auto button operation)

2 beeps  $\updownarrow$  1 beep (remote control unit rear, setting terminals shorted)

Receiving beep sound muted ... Receiving beep sound heard (long beep)  
(Auto button operation)

\* If the auto button is pressed and 26 seconds or so are allowed to elapse, the auto button operation mode is restored. When nothing happens for 60 seconds in the "Setting mode", "Odour clear setting mode" or "individual setting mode" or if a remote control code is received, the mode concerned is canceled.

### 9.6.2. Drain Test (SW1)

When installing the unit and you want the drain pump to operate independently, press the DRAIN TEST switch to operate it for about 5 minutes.

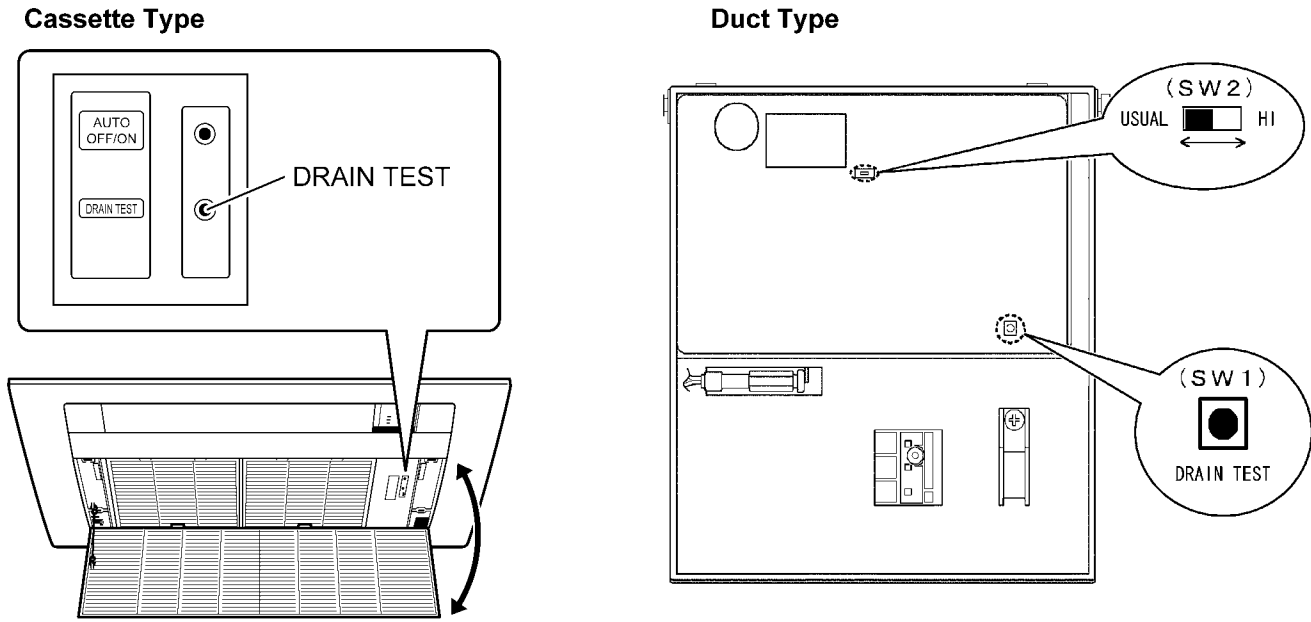

### 9.6.3. High Static Pressure Switch (High state switch SW2) (For Duct Type)

To increase the fan speed, open the control box and on the control board switch the HIGH STATE switch (SW2) to "HI".



### 9.6.4. Self Diagnosis display

The diagnostic displays that appear when trouble has occurred can be checked using the remote control unit.

When trouble occurs, operation is stopped automatically, and the timer lamp blinks. The diagnosis time has been reduced by warning the user by means of the blinking of the timer lamp.

- When trouble occurs, operation is stopped automatically, and the timer lamp blinks.
- The timer lamp will go off if the power is turned off, but it will start blinking again if the air conditioner is operated with the trouble left unremedied.
- No diagnostic displays will appear when the unit is operated after the trouble has been remedied. However, the last diagnostic symbol is stored in the IC's memory. (This symbol can be cleared.)
- When the air conditioner protection operation is triggered because the air conditioner is being operated under overload conditions, its heat radiation is being interfered with or anti-freezing operation is initiated or because its supply voltage has dropped or its power has been turned off and then back on during operation, for instance, no diagnostic displays will appear. However, **F99** and other such information are stored in the IC's memory: this is normal and not indicative of malfunctioning.

· **The diagnostic displays appear automatically when trouble occurs.**

1. Operation is stopped automatically.
2. The timer lamp of the display unit on the indoor unit blinks.
3. The timer lamp goes off when the power is turned off.

· **To display the trouble (or protection operation) status stored in the memory**

1. Turn on the power.
2. Open the remote control unit's door, and press the timer setting "UP-ARROW" button for 5 seconds.
3. Press the "UP-ARROW" button slowly and repeatedly until 4 beeps are heard continuously from the indoor unit.
4. The 3-digit alphanumeric display on the remote control unit indicates the trouble which has occurred.

\* If the 3-digit alphanumeric display on the remote control unit and the nature of the trouble match, the operation lamp (green) will light.

· **To clear the trouble (or protection operation) status stored in the memory after remedial action has been taken**

1. Set forced cooling operation by pressing Auto button 5 to 8 seconds.
2. Remove the battery cover from remote control.
3. The air conditioner can then be forcibly reset by shorting the RESET terminals toward the main unit. (one short receiving beep)

The procedure is applied to all of Cassette, Duct and Wall type models.

· **Concerning emergency operation (which can be performed in some of the trouble conditions)**

1. Using the remote control unit, select COOL or HEAT, and press the operation OFF/ON button. (4 receiving beeps are heard, and the timer lamp blinks.)
2. The air conditioner can now be used temporarily until its trouble is remedied.

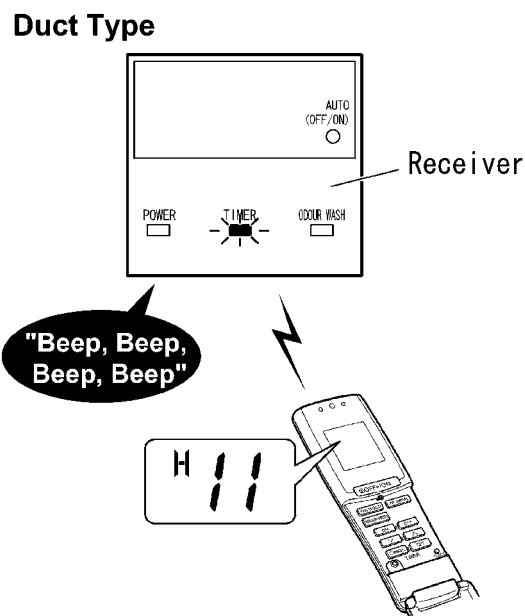
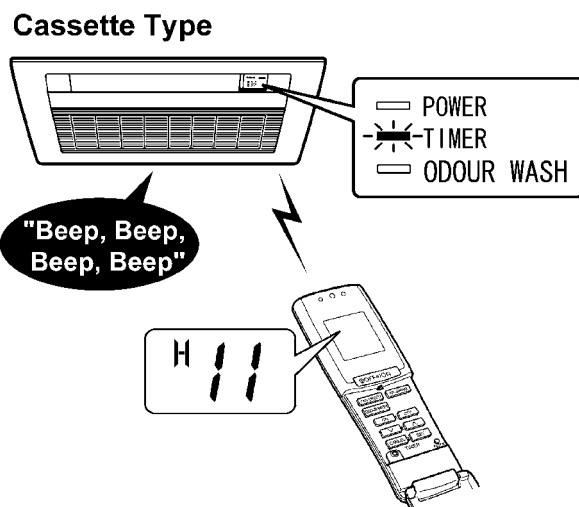

Characters allowing temporary operation	Possible temporary operations	Description of operation
H23	Cooling	Emergency operation with limited functions. (The Timer LED continues to blink.)
H27	Heating	
H28	Cooling	

### 9.6.4.1. Error Cord

Symbol	Diagnosis	Diagnosis method
H11	Indoor/Outdoor abnormal communication	This trouble display appears when indoor/outdoor unit communication fails to be established after 30 or more seconds. <b>&lt;Diagnosis checkpoint&gt;</b> 1. Measure the voltages of the indoor/outdoor unit communication cables, and check whether the voltage is being supplied properly to the outdoor unit or whether it is being returned from the outdoor unit to the indoor units.
H12	Indoor unit capacity unmatched	This trouble display appears when wrong in the total connection capacity and wrong connection in each capacity. The trouble is determined within 2 minutes after the power is turned on. <b>&lt;Diagnosis checkpoint&gt;</b> 1. Check the total capacity of the units connected and check that the models are compatible for connection.
H14	Intake air temp. sensor	This trouble display appears when the intake air temperature has exceeded above 46 °C continuously for 2 minutes or dropped below -54 °C continuously for 5 seconds during operation. <b>&lt;Diagnosis checkpoint&gt;</b> 1. This trouble display appears when a temperature which is impossibly high or low from a normal standpoint has been detected.  Check the sensor, and if open-circuiting (more than 500 kΩ) or short-circuiting (less than 6.5 kΩ) is not found, defective contact of the connector is to blame.
H16	Outdoor Current Transformer	When the total current has dropped below the set current level continuously for 20 seconds during operation beyond the set capacity, operation is stopped. Three minutes later, operation is started up again, and when the trouble occurs on 4 successive occasions, the trouble display appears (the timer lamp blinks). <b>&lt;Diagnosis checkpoint&gt;</b> 1. Check the refrigerating cycle: Gas may be leaking (the amount of refrigerant is extremely low). 2. Check the control P.C. Board: Check for a broken wire (open circuit) in the current transformer. (If an open circuit is found, replace the control P.C. Board.)  In the case of a scroll compressor (DC motor), H16 is detected only when the regular compressor is operating.
H19	Indoor fan motor mechanism lock	· High-voltage PWM: When a state in which the fan motor speed is not synchronized with the control signal has been detected on 7 successive occasions:  · Low-voltage PAM: When the fan lock detection signal has been detected on 7 successive occasions or it has been detected continuously for 25 seconds or when a state in which the fan motor speed is not synchronized with the control signal has been detected on 7 successive occasions:  The trouble display appears (the timer lamp blinks). <b>&lt;Diagnosis checkpoint&gt;</b> 1. Check the nature of the fan lockup trouble. 2. Check for disconnections of the fan motor connectors and for defects in contact, in the fan motor and in the control P.C. Board.
H21	Indoor float switch abnormality	Error appears when the float switch is open for 150 seconds. <b>&lt;Diagnosis checkpoint&gt;</b> 1. Drain blockage 2. Check the conductivity of float switch. 3. Check that the resistance of the drain motor is about 200 Ω
H23	Indoor heat exchanger temp. sensor	This trouble display appears when a temperature of under approximately -40 °C or above approximately 80 °C has been detected by the heat exchanger temperature sensor continuously for 5 seconds. (This trouble is not detected during de-icing.) <b>&lt;Diagnosis checkpoint&gt;</b> 1. This trouble display appears when a temperature which is impossibly high or low from a normal standpoint has been detected.  Check the sensor, and if open-circuiting (more than 500 kΩ) or short-circuiting (less than 2.5 kΩ) is not found, defective contact of the connector or a defective control P.C. Board is to blame.
H27	Outdoor air temp. sensor	This trouble display appears when a temperature of under approximately -40 °C or above approximately 150 °C has been detected by the outside air temperature sensor for 2 to 5 seconds. (This trouble is not detected during de-icing.) <b>&lt;Diagnosis checkpoint&gt;</b> 1. This trouble display appears when a temperature which is impossibly high or low from a normal standpoint has been detected.  Check the sensor, and if open-circuiting (more than 500 kΩ) or short-circuiting (less than 0.5 kΩ) is not found, defective contact of the connector or a defective control P.C. Board is to blame.
H28	Outdoor heat exchanger temp. sensor 1	This trouble display appears when a temperature of under approximately -60 °C or above approximately 110 °C has been detected by the heat exchanger temperature sensor for 2 to 5 seconds. (This trouble is not detected during de-icing.) <b>&lt;Diagnosis checkpoint&gt;</b> 1. This trouble display appears when a temperature which is impossibly high or low from a normal standpoint has been detected.  Check the sensor, and if open-circuiting (more than 500 kΩ) or short-circuiting (less than 0.5 kΩ) is not found, defective contact of the connector or a defective control P.C. Board is to blame.

Symbol	Diagnosis	Diagnosis method
H30	Outdoor discharge pipe temp. sensor	<p>Disconnected discharge sensor</p> <ul style="list-style-type: none"> <li>When the condensation temperature is higher than the discharge temperature + (plus) 6 °C, a sensor disconnection is detected, operation stops, and the trouble display appears (the timer lamp blinks).</li> </ul> <p><b>&lt;Diagnosis checkpoint&gt;</b></p> <ol style="list-style-type: none"> <li>This trouble display appears when a temperature which is impossibly high or low from a normal standpoint has been detected.</li> </ol> <p>Check the sensor, and if open-circuiting (more than 500 kΩ) or short-circuiting (less than 0.5 kΩ) is not found, defective contact of the connector or a defective control P.C. Board is to blame.</p>
H32	Outdoor heat exchanger temp. sensor 2 (discharge pipe temp.)	<p>This trouble display appears when a temperature of under approximately -60 °C or over approximately 110 °C has been detected continuously for 2 to 5 seconds by the outlet temperature sensor of the heat exchanger.</p> <p><b>&lt;Diagnosis checkpoint&gt;</b></p> <ol style="list-style-type: none"> <li>This trouble display appears when a temperature which is impossibly high or low from a normal standpoint has been detected.</li> </ol> <p>Check the sensor, and if open-circuiting (more than 500 kΩ) or short-circuiting (less than 0.5 kΩ) is not found, defective contact of the connector or a defective control P.C. Board is to blame.</p>
H34	Outdoor heat sink temp. sensor	<p>This trouble display appears when a temperature of under -43 °C or above 80 °C has been detected by the outdoor unit radiator fin sensor continuously for 2 seconds.</p> <p><b>&lt;Diagnosis checkpoint&gt;</b></p> <ol style="list-style-type: none"> <li>This trouble display appears when a temperature which is impossibly high or low from a normal standpoint has been detected.</li> </ol> <p>Check the sensor, and if open-circuiting (more than 500 kΩ) or short-circuiting (less than 0.5 kΩ) is not found, defective contact of the connector or a defective control P.C. Board is to blame.</p>
H35	Drainage or drain pump abnormality	<p>This error appears if the float switch is open three times for ten seconds or more during a twenty-minute period.</p> <p><b>&lt;Diagnosis checkpoint&gt;</b></p> <ol style="list-style-type: none"> <li>Drain blockage</li> <li>Check the conductivity of float switch.</li> <li>Check that the resistance of the drain motor is about 200 Ω</li> </ol>
H36	Outdoor gas pipe temp. sensor	<p>This trouble display appears when a temperature of under approximately -45 °C or above approximately 149 °C has been detected by the outdoor unit gas side pipe temperature sensor continuously for 2 to 5 seconds.</p> <p><b>&lt;Diagnosis checkpoint&gt;</b></p> <ol style="list-style-type: none"> <li>This trouble display appears when a temperature which is impossibly high or low from a normal standpoint has been detected.</li> </ol> <p>Check the sensor, and if open-circuiting (more than 500 kΩ) or short-circuiting (less than 0.5 kΩ) is not found, defective contact of the connector or a defective control P.C. Board is to blame.</p>
H37	Outdoor liquid pipe temp. sensor	<p>This trouble display appears when a temperature of under -45 °C or above 149 °C has been detected by the outdoor unit liquid side pipe temperature sensor continuously for 2 seconds.</p> <p><b>&lt;Diagnosis checkpoint&gt;</b></p> <ol style="list-style-type: none"> <li>This trouble display appears when a temperature which is impossibly high or low from a normal standpoint has been detected.</li> </ol> <p>Check the sensor, and if open-circuiting (more than 500 kΩ) or short-circuiting (less than 0.5 kΩ) is not found, defective contact of the connector or a defective control P.C. Board is to blame.</p>
H39	Abnormal indoor operating unit or standby units	<p>This display appears in rooms other than one in which indoor freezing trouble has occurred when the pipes have been connected incorrectly, when an outdoor expansion valve is defective or when an expansion valve connector has become disconnected.</p>
H41	Abnormal wiring or piping connection	<p>CU-2E only</p> <p>This display appears when this kind of trouble is detected 3 minutes after a forced cooling operation was conducted for one room during the initial operation after the power was turned on. It appears when:</p> <ul style="list-style-type: none"> <li>The indoor unit pipe temperature in a room without the capacity supply available at an outside air temperature above 5 °C has dropped by more than 20 °C to 5 °C or lower 3 minutes after the compressor started up.</li> <li>The outdoor unit gas pipe temperature in a room without the capacity supply available has dropped by more than 5 °C to 5 °C or lower 3 minutes after the compressor started up.</li> </ul>
H97	Outdoor fan motor mechanism lock	<p>When the fan motor speed detected when its maximum output is demanded is below 30 rpm continuously for 15 seconds, the fan motor stops for 3 minutes and then restarted.</p> <p>When this happens on 16 occasions (the trouble display is cleared when the value is normal for 5 minutes), the H97 diagnostic symbol is stored in the memory, and the fan motor stops.</p> <p><b>&lt;Diagnosis checkpoint&gt;</b></p> <ol style="list-style-type: none"> <li>Check the nature of the fan lockup trouble.</li> <li>Check for disconnections of the fan motor connectors and for defects in contact, in the fan motor and in the control P.C. Board.</li> </ol>
H98	Indoor high pressure protection	<p>The restriction on the compressor frequency is started when the temperature of the indoor unit heat exchanger source is between 50 °C and 52 °C, the compressor stops at a temperature from 62 °C to 65 °C, it is restarted 3 minutes later at below 62 °C to 65 °C, and the restriction on the compressor frequency is released at a temperature between 48 °C and 50 °C. (No trouble display appears.)</p> <p><b>&lt;Diagnosis checkpoint&gt;</b></p> <ol style="list-style-type: none"> <li>Check the indoor unit heat exchanger temperature sensor (check for changes in its characteristics and check its resistance): Symptoms include no hot start when operation is started, a failure of the thermostat to turn on (no outdoor unit operation). And frequent repetition of stopping and startup.</li> <li>Check also for short circuits indoors and clogging of the air filters.</li> </ol>

Symbol	Diagnosis	Diagnosis method
H99	Indoor operating unit freezing	<p>The restriction on the compressor frequency is started when the indoor unit heat exchanger temperature is between 8 °C and 12 °C. Operation stops if a temperature below 0 °C continues for 6 minutes. Three minutes later, operation is started up at a temperature from 3 °C to 8 °C. The restriction on the compressor frequency is released at a temperature between 13 °C and 14 °C.</p> <p><b>&lt;Diagnosis checkpoint&gt;</b></p> <ol style="list-style-type: none"> <li>1. <b>A cooling or dry mode operation conducted at a low outside air temperature is mainly to blame: this is not indicative of any malfunctioning.</b></li> </ol> <p><b>If the outside air temperature rises during automatic operation in the winter months, the dry mode operation is selected. The H99 diagnostic display also appears at such a time.</b></p> <ol style="list-style-type: none"> <li>2. Check the refrigerating cycle: Gas may be leaking (the amount of refrigerant is low) or a pipe may be broken, etc.</li> <li>3. Check also for short circuits indoors and clogging of the air filters.</li> </ol>
F11	4-way valve switching failure	<p>When a difference of 0 °C to 5 °C has been detected between the outdoor unit heat exchanger temperature and liquid side pipe temperature on 5 occasions, the trouble display appears.</p> <p><b>&lt;Diagnosis checkpoint&gt;</b></p> <ol style="list-style-type: none"> <li>1. Check the 4-way valve coil: Check that no power is supplied to the coil during cooling and dry mode operations, and that power is supplied during heating operations. Inspect the coil for broken wires (open circuits).</li> <li>2. If the coil is trouble-free, the switching action of the 4-way valve may be defective.</li> </ol>
F17	Indoor standby units freezing	<p>When the difference of an intake temperature (room temperature sensor) and the indoor unit heat exchanger temperature (piping sensor) is higher than 10 °C or an indoor unit heat exchanger temperature of below -1 °C has been detected continuously for 5 minutes, operation stops. Three minutes later, it is started up, and the trouble display appears when this has occurred on 3 consecutive occasions.</p> <p><b>&lt;Diagnosis checkpoint&gt;</b></p> <ol style="list-style-type: none"> <li>1. Check the refrigerating cycle: Expansion valve leakage</li> <li>2. Check the indoor unit pipe temperature sensor (check for changes in its characteristics and check its resistance).</li> </ol>
F90	PFC circuit protection	<p>When a DC voltage over 393V to 424V has been detected on 16 occasions, this trouble display appears.</p> <p><b>&lt;Diagnosis checkpoint&gt;</b></p> <ol style="list-style-type: none"> <li>1. To check whether the shutting valve has been left close by mistake, operation is performed for one to several minutes after the compressor has started up, F93 is stored in the memory as the symptom, and operation stops.</li> <li>2. Check the inverter circuit (for open circuits) in the control P.C. Board: Check the IPM base current (6 locations) within 3 minutes after the power has been turned back on. As the symptom, F93 is stored in the memory 30 seconds after the compressor has started up, and operation stops. The trouble display appears after 4 restarts.</li> <li>3. Check for broken wires (open circuits) in the compressor winding: Approximately 1 ohm under normal conditions for each phase (same symptom as in 2.)</li> <li>4. Check the power supply voltage has been fluctuating or not.</li> </ol>
F91	Refrigeration cycle abnormality	<p>When the compressor frequency is above 55 Hz and the current drops below the prescribed level continuously for 7 minutes, operation stops, and it is restarted 3 minutes later.</p> <p>When the compressor discharge temperature has exceeded the setting and the expansion valve has remained fully open for 80 seconds, operation stops, and it is restarted 3 minutes later.</p> <p>When the stopping described above has occurred on 4 occasions, operation stops, and the trouble display appears.</p> <p><b>&lt;Diagnosis checkpoint&gt;</b></p> <ol style="list-style-type: none"> <li>1. Check the refrigerating cycle: Gas may be leaking (more than one-half of the volume of the gas has gone). The diagnostic displays resulting from a gas leak generally change in the following sequence depending on the extent of the gas leak: H99 → F97 → F91 → H16.</li> </ol> <p>The range of this trouble (F91) is limited. (Compressor protection at the start of the season)</p>
F93	Compressor abnormal revolution	<p>When a state in which the rotation of the compressor is not synchronized with the control signal has been detected on 8 successive occasions, operation stops, and the trouble display appears.</p> <p><b>&lt;Diagnosis checkpoint&gt;</b></p> <ol style="list-style-type: none"> <li>1. To check whether the shutting valve has been left close by mistake, operation is performed for one to several minutes after the compressor has started up, F93 is stored in the memory as the symptom, and operation stops.</li> <li>2. Check the inverter circuit (for open circuits) in the control P.C. Board: Check the IPM base current (6 locations) within 3 minutes after the power has been turned back on. As the symptom, F93 is stored in the memory 30 seconds after the compressor has started up, and operation stops. The trouble display appears after 4 restarts.</li> <li>3. Check for broken wires (open circuits) in the compressor winding: Approximately 1 ohm under normal conditions for each phase (same symptom as in 2.)</li> </ol>
F95	Outdoor high pressure protection	<p>CU-2E only</p> <p>When the temperature of the outdoor unit heat exchanger temperature sensor exceeds 62 °C, the F95 diagnostic symbol is stored in the memory, and operation stops. 13 minutes later, operation is restarted at a temperature below 48 °C. This trouble display appears when this happens on 4 occasions in a 20-minute period.</p> <p><b>&lt;Diagnosis checkpoint&gt;</b></p> <ol style="list-style-type: none"> <li>1. Check the outdoor unit heat exchanger temperature sensor (check for changes in its characteristics and check its resistance).</li> <li>2. Check whether something is interfering with the dissipation of the heat outdoors.</li> </ol>

Symbol	Diagnosis	Diagnosis method
F96	IPM (Power transistor module) or compressor overheating	<p>When this trouble is detected from the electrical parts radiation fin temperature sensor and OLP output during operation, operation stops, and it is restarted 3 minutes later. If the trouble occurs on 4 occasions, operation stops, and the trouble display appears.</p> <p><b>&lt;Diagnosis checkpoint&gt;</b></p> <ol style="list-style-type: none"> <li>1. Something may be interfering with the dissipation of the heat outdoors or the outdoor unit fan may be defective. (The outdoor unit fan is not running.)</li> <li>2. Defective IPM (outdoor unit control P.C. Board)</li> <li>3. Gas leaks. Shutting valve is not opened.</li> </ol>
F97	Compressor high discharge temperature	<p>This trouble display appears and operation stops when this happens on 6 occasions (it is cleared when the operation is normal for 20 minutes).</p> <p><b>&lt;Diagnosis checkpoint&gt;</b></p> <ol style="list-style-type: none"> <li>1. Check the refrigerating cycle: Gas may be leaking (the amount of refrigerant is low). The stopping of the outdoor unit from time to time is a symptom of this trouble.</li> <li>2. When operation steps with this trouble display appearing, check the compressor temperature sensor (check for changes in its characteristics and check its resistance).</li> <li>3. Something may be interfering with the dissipation of the heat outdoors or the outdoor unit fan may be defective. (The fan will not run because of an open circuit.)</li> </ol> <p>(The protection function may be activated by an overload, and the F97 trouble display will remain stored in the memory.)</p>
F98	Total running current protection	<p>When the total current exceeds the setting (17A to 20A), frequency control is started, and if it then exceeds the setting, operation stops, and the trouble display appears.</p> <p><b>&lt;Diagnosis checkpoint&gt;</b></p> <ol style="list-style-type: none"> <li>1. Check the AC voltage at the outdoor unit terminal board during operation: The voltage drop must be within 5% of the voltage when operation has stopped (<math>\pm 110\%</math> of rated voltage even during operation). If the voltage drop exceeds 5% or if the voltage changes suddenly, inspect whether the power supply cord and indoor/outdoor unit connection cables are too long or too small in diameter, etc.</li> <li>2. Check whether something is interfering with the dissipation of the heat outdoors (during cooling operations): Normally, the capacity is limited by the current so that the outdoor unit don't stop, and the diagnostic display does not appear.</li> </ol>
F99	DC peak detection	<p>When "Output current trouble", which occurs when the prescribed current level is exceeded, has occurred on 16 consecutive occasions, operation stops, and the trouble display appears.</p> <p><b>&lt;Diagnosis checkpoint&gt;</b></p> <ol style="list-style-type: none"> <li>1. Check whether the compressor is defective (locked up or shorted winding). Check the outdoor unit control P.C. Board.</li> </ol>

# 10 Installation Instructions

## 10.1. Cassette Type

# Installation Instructions

Required tools for Installation Works		
1. Philips screw driver	7. Reamer	14. Torque wrench
2. Level gauge	8. Knife	18 N•m (1.8 kgf.m)
3. Electric drill, hole core drill (ø70 mm)	9. Gas leak detector	42 N•m (4.2 kgf.m)
4. Hexagonal wrench (4 mm)	10. Measuring tape	15. Vacuum pump
5. Spanner	11. Thermometer	16. Gauge manifold
6. Pipe cutter	12. Megameter	
	13. Multimeter	

### SAFETY PRECAUTIONS

- Read the following "SAFETY PRECAUTIONS" carefully before installation.
- Electrical work must be installed by a licensed electrician. Be sure to use the correct rating of the power plug and main circuit for the model to be installed.
- The caution items stated here must be followed because these important contents are related to safety. The meaning of each indication used is as below. Incorrect installation due to ignoring of the instruction will cause harm or damage, and the seriousness is classified by the following indications.

	<b>WARNING</b>	This indication shows the possibility of causing death or serious injury.
	<b>CAUTION</b>	This indication shows the possibility of causing injury or damage to properties only.



The items to be followed are classified by the symbols:



	Symbol with background white denotes item that is PROHIBITED from doing.
--	--



- Carry out test running to confirm that no abnormality occurs after the installation. Then, explain to user the operation, care and maintenance as stated in instructions. Please remind the customer to keep the operating instructions for future reference.

<b>WARNING</b>	
1) Engage dealer or specialist for installation. If installation done by the user is defective, it will cause water leakage, electrical shock or fire.	
2) Install according to this installation instruction strictly. If installation is defective, it will cause water leakage, electrical shock or fire.	
3) Use the attached accessories parts and specified parts for installation. Otherwise, it will cause the set to fall, water leakage, fire or electrical shock.	
4) Install at a strong and firm location which is able to withstand the set's weight. If the strength is not enough or installation is not properly done, the set will drop and cause injury.	
5) For electrical work, follow the local national wiring standard, regulation and this installation instruction. An independent circuit and single outlet must be used. If electrical circuit capacity is not enough or defect found in electrical work, it will cause electrical shock or fire.	
6) Use the specified cable (1.5 mm <sup>2</sup> ) and connect tightly for indoor/outdoor connection. Connect tightly and clamp the cable so that no external force will be acted on the terminal. If connection or fixing is not perfect, it will cause heat-up or fire at the connection.	
7) Wire routing must be properly arranged so that control board cover is fixed properly. If control board cover is not fixed perfectly, it will cause heat-up at connection point of terminal, fire or electrical shock.	
8) When carrying out piping connection, take care not to let air substances other than the specified refrigerant go into refrigeration cycle. Otherwise, it will cause lower capacity, abnormal high pressure in the refrigeration cycle, explosion and injury.	
9) When connecting the piping, do not allow air or any substances other than the specified refrigerant (R410A) to enter the refrigeration cycle. Otherwise, this may lower the capacity, cause abnormally high pressure in the refrigeration cycle, and possibly result in explosion and injury.	
10) Do not modify the length of the power supply cord or use of the extension cord, and do not share the single outlet with other electrical appliances. Otherwise, it will cause fire or electrical shock.	
<b>CAUTION</b>	
1) This equipment must be earthed. It may cause electrical shock if grounding is not perfect.	
2) Do not install the unit at place where leakage of flammable gas may occur. In case gas leaks and accumulates at surrounding of the unit, it may cause fire.	
3) Carry out drainage piping as mentioned in installation instructions. If drainage is not perfect, water may enter the room and damage the furniture.	
<b>ATTENTION</b>	
1) Selection of the installation location. Select a installation location which is rigid and strong enough to support or hold the unit, and select a location for easy maintenance.	
2) Do not release refrigerant. Do not release refrigerant during piping work for installation, reinstallation and during repairing a refrigeration parts. Take care of the liquid refrigerant, it may cause frostbite.	
3) Installation work. It may need two people to carry out the installation work.	
4) Do not install this appliance in a laundry room or other location where water may drip from the ceiling, etc.	

### Indoor Unit Accessory Parts

No.	Accessory part	Qty.
1	Piping insulation 	2
2	Band 	4
3	Remote control 	1

No.	Accessory part	Qty.
4	Battery 	2
5	Remote control holder 	1
6	Remote control holder fixing screw 	2

No.	Accessory part	Qty.
7	Drain joint 	1
8	Pattern 	1
9	Pattern fixing screw 	4

### Required Materials

Part name	Part number
Decorative grille	CZ-BT20P (white)

### Other Items to be Prepared (Locally Purchased)

Product name	Remarks
Rigid PVC pipe	VP20 (outer diameter ø26) ; also sockets, elbows and other parts as necessary
Adhesive	PVC adhesive
Insulation	For refrigerant piping insulation (foamed polyethylene with a thickness of 8 mm or more) For drain piping insulation (foamed polyethylene with a thickness of 10 mm or more)
Indoor/outdoor connecting cable	4×1.5 mm <sup>2</sup> flexible cord, type designation 245 IEC 57 (H05RN-F) (See "Connecting the Indoor/Outdoor Connecting Cable".)
Hanging bolt related parts	Hanging bolts (M10) (4) and nuts (12), Flat washers (8)

## 1 Selecting the Installation Location

Determine the location with the agreement of the customer.

### Indoor unit

- The location should be strong enough to support the main unit without vibration.
- There should not be any heat or steam sources nearby.
- Drainage should be easy. Avoid locating the drain port close to ditches (domestic wastewater).
- Avoid locations above entrances and exits.
- Ensure the distances indicated by the ↔ marks in the illustration.
- Ensure sufficient space for installation and servicing.
- The ceiling surface (lower surface) should be level.
- Locate the indoor unit at least 1 m or more away from a TV, radio, wireless equipment, antenna cables and fluorescent lights, and 2 m or more away from a telephone.

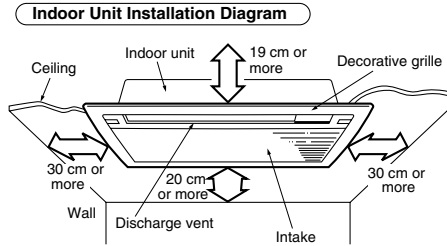

Note that if the air conditioning unit is installed near an electronically lit fluorescent light (inverter, rapid start type, etc.), it may not receive the remote control signals.

### Remote control mounting location

- Signals may not be transmitted and received correctly when the remote control is operated while in the holder. Take the remote control in your hand to operate the unit.
- Mount the holder in a location that is not subject to the effects of heat (direct sunlight and stoves, etc.).

### Attaching the remote control holder to the wall

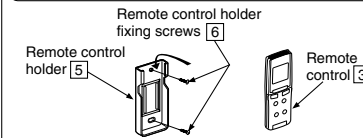

## 2 Selecting the Piping

- Prepare the piping set shown in the table below or equivalent products for the refrigerant piping.

Liquid side	ø 6.35 (1/4") t 0.8
Gas side	ø 9.52 (3/8") t 0.8

\* See the Outdoor Unit Installation Instructions.

## 3 To Drill a Hole in the Wall and Install a Sleeve of Piping

1. Insert the piping sleeve to the hole.
2. Fix the bushing to the sleeve.
3. Cut the sleeve until it extrudes about 15 mm from the wall.

### CAUTION

When the wall is hollow, please be sure to use the sleeve for tube ass'y to prevent dangers caused by mice biting the connecting cable.

4. Finish by sealing the sleeve with putty or caulking compound at the final stage.

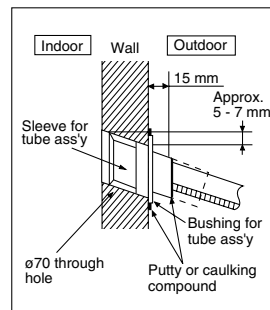

## 4 Installation Dimensions

- Select the unit position and airflow direction so that the cool and warm air spreads throughout the whole room.
- Secure the hanging bolts (M10, locally purchased) firmly in the manners shown below in a location that is capable of supporting the unit weight.
- When the ceiling materials insufficient strength, it may be necessary to make an opening in the ceiling and add a framework or other reinforcing structure to maintain the levelness of the ceiling and prevent ceiling vibration. Consult a construction or interior contractor for details.

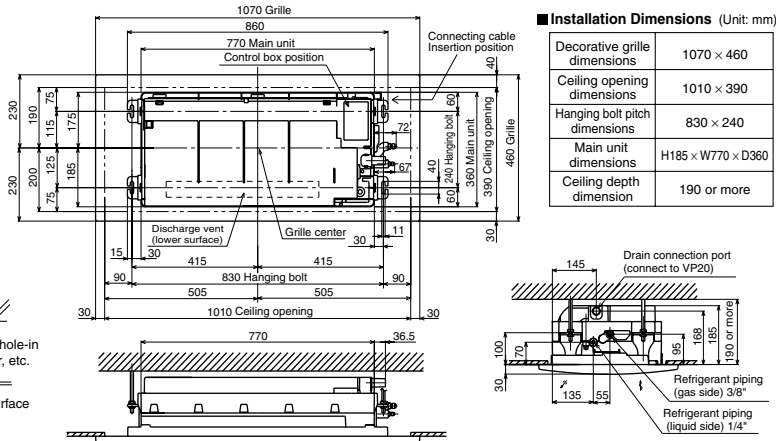
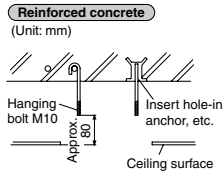
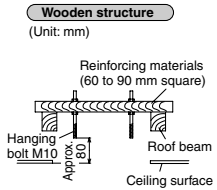

## 5 Installing the Indoor Unit

- Attach the nuts and washers to the hanging bolts, then lift up and hook the main unit onto the hanging fixtures.
- Adjust the lower surface of the ceiling indoor unit relative to the ceiling surface as shown in the illustration below.
- Check the levelness using a level or a vinyl hose filled partially with water before tightening the nuts.

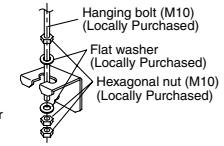

**CAUTION**  
Note that if the main unit is not level or if the height relative to the ceiling surface is not appropriate, water may leak or condense around the discharge vent.

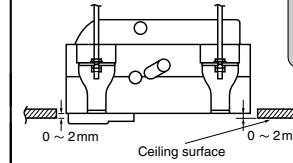

## 6 Connecting the Drain Piping

- Lay the drain piping so as to ensure drainage.
- Use a locally purchased VP20 rigid PVC pipe (outer diameter ø26) for the drain piping, and connect it to the drain port of the indoor unit using the drain joint [7]. Coat both sides with a PVC adhesive and adhere them firmly.
- Drain piping located indoors should always be insulated by wrapping with locally purchased insulation (foamed polyethylene with a thickness of 10 mm or more).
- The drain piping should have a downward gradient (1/50 or more), and should be secured using pipe hanging equipment to avoid creating hills or traps partway.

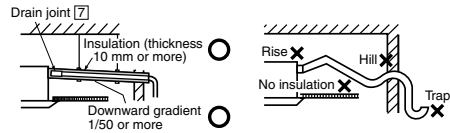

- Should some obstacle prevent the drain piping from being extended smoothly, the drain piping can be raised outside the main unit as shown in the illustration below.

**CAUTION**  
Absolutely do not install and extend the drain piping from the main unit drain water outlet horizontally or upward or raise it 20cm or more. Doing so may result in poor drainage or cause of drain motor failure.

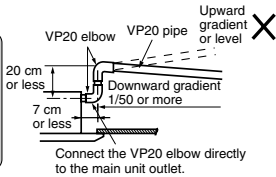

**Check the drainage** Check after connecting the power supply.

- Pour approximately 300 to 400 cc of water into the drain pan of the main unit. (Pour the water from a squeeze bottle or other vessel as shown in the illustration below.)
- Press the "DRAIN TEST" switch located on the control box to start the drain motor, and check that the water drains normally. (The drain motor operates for approximately 5 minutes and then stops automatically.)

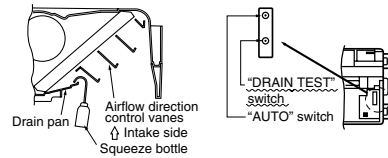

## 7 Connecting and Insulating the Refrigerant Piping

- Tighten the refrigerant piping using the torque shown in the table to the right.
- Cover the piping joint with piping insulation [1] and tie the insulation firmly using two bands [2] on both sides. Be sure to adhere the insulation closely so that there is no gap between the main unit and the piping insulation.
- When the relative humidity inside the ceiling (indoors) is thought to exceed 80% such as in a new building during the rainy season or a new reinforced concrete structure, moisture may condense on the outer surface of the piping insulation. In this case be sure to add further insulation to the refrigerant piping.

**CAUTION**  
Hold the half-union with a wrench, and do not rotate the male side.

Pipe diameter	Tightening torque
Liquid side ø6.35 (1/4")	18N · m (1.8 kgf · m)
Gas side ø9.52 (3/8")	42N · m (4.2 kgf · m)

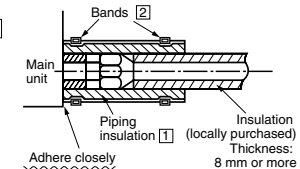
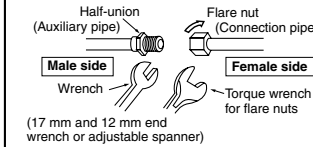



## 8 Connecting the Indoor/Outdoor Connecting Cable

- Remove the control box cover and insert the cable into the main unit through the cable holder located on the side.
- Check the colors of the wires on the terminal board, and secure them with screws.
- Secure the outer sheath of the connecting cable with the cord clamp.
- Reattach the control box cover in its original position.

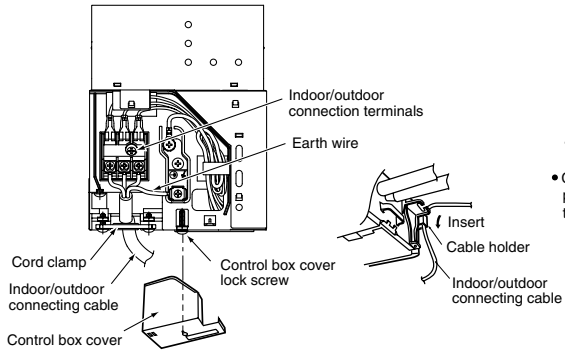

- Connecting cable between indoor unit and outdoor unit shall be approved polychloroprene sheathed  $4 \times 1.5 \text{ mm}^2$  flexible cord, type designation 245 IEC 57(H05RN-F) or heavier cord.
- Ensure the color of wires of outdoor unit and the terminal Nos. are the same to the indoor's respectively.
- Earth lead wire shall be longer than the other lead wires as shown in the figure for the electrical safety in case of the slipping out of the cord from the anchorage.

Terminals on the indoor unit	1	2	3	
Color of wires				
Terminals on the outdoor unit	1	2	3	

- Secure the cable onto the control board with the holder (clammer).
- Connect the indoor/outdoor connecting cable using the prescribed cable, and secure it firmly so that external force from the cable is not transmitted to the terminal connectors.

## 9 Attaching the Decorative grille

- Lift up the decorative grille from directly below to match it with the main unit, and tentatively secure it in place.
- Open the intake grille and the screw caps, and secure the decorative grille using the lock screws (4).

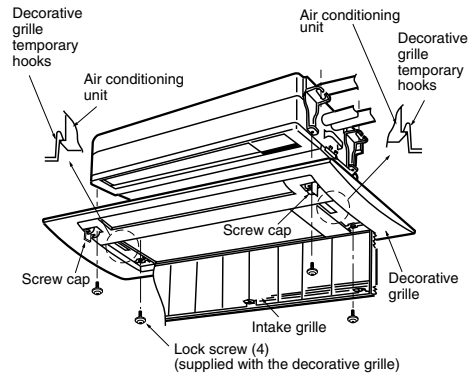

### Opening the Intake Grille

Press the three locations shown below and open the grille.



### Opening the Screw Caps

Press the edge (outside) of the screw cap to open it.

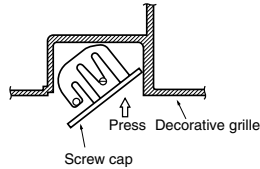

## Using the Pattern 8

- When finishing the ceiling after the air conditioner has been installed, use the pattern 8 to indicate the ceiling opening dimensions as shown below. (The protection sheet of the pattern is used to prevent the air conditioner discharge vent from becoming dirty, so wrap it around the discharge vent as shown in the illustration.)

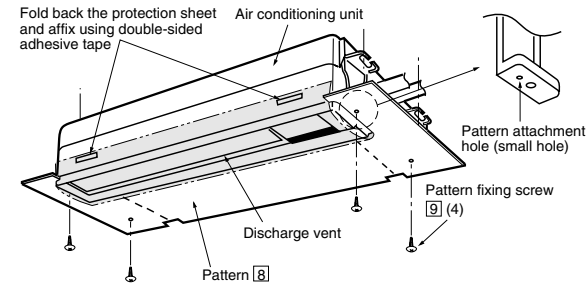

### AUTO SWITCH OPERATION

The below operations will be performed by pressing the "AUTO" switch.

1. AUTO OPERATION MODE  
The Auto operation will be activated immediately once the "AUTO" switch is pressed.

2. TEST RUN OPERATION (FOR PUMP DOWN/SERVICING PURPOSE)

The Test Run operation will be activated if the "AUTO" switch is pressed continuously for more than 5 sec. to below 8 sec..  
A short beep sound will occur at the fifth sec., in order to identify the starting of Test Run operation.

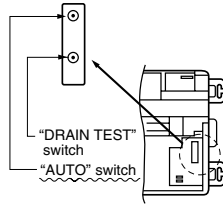

### Changing the remote control transmission code

- When installing two air conditioners in one room, each air conditioner can be synchronized to the remote control.  
In order to operate separately, open the rear cover of one of the remote control and set to "B".

Set "B" on the remote control.  
This can be achieved by cutting the jumper wire of the remote control with a cutter.

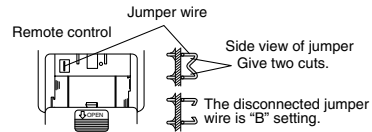

Setting the air conditioner unit to "B"

1. Press the "AUTO" switch for about 11 to 15 seconds. When you hear three short beeps, release the switch.  
Note: you will hear one short beep in about 5 seconds, and then two short beeps in about 8 seconds.
2. Press again the "AUTO" switch within 60 seconds. Every press the "AUTO" switch, you will hear a short beep. When you hear eventually a long beep, stop pressing the "AUTO" switch, which achieves "B" setting.  
If you stop pressing the "AUTO" switch midway at the short beep, this will achieve "A" setting.
3. After 60 seconds or longer of the above setting, use the "B" set remote control to confirm successful operation.

### CHECK ITEMS

- |  |   |
|--|---|
| <input type="checkbox"/> Is there any gas leakage at flare nut connections?                | <input type="checkbox"/> Is the earth wire connection properly done?            |
| <input type="checkbox"/> Has the heat insulation been carried out at flare nut connection? | <input type="checkbox"/> Is the power supply voltage complied with rated value? |
| <input type="checkbox"/> Is the connecting cable being fixed to terminal board firmly?     | <input type="checkbox"/> Is there any abnormal sound?                           |
| <input type="checkbox"/> Is the connecting cable being clamped firmly?                     | <input type="checkbox"/> Is the cooling / heating operation normal?             |
| <input type="checkbox"/> Is the drainage ok?<br>(Refer to "Check the drainage" section)    | <input type="checkbox"/> Is the thermostat operation normal?                    |
|  | <input type="checkbox"/> Is the remote control's LCD operation normal?          |

MATSUSHITA ELECTRIC INDUSTRIAL CO., LTD.

Web Site : <http://www.panasonic.co.jp/global/>

ENGLISH

F612424

PRINTED IN JAPAN

## 10.2. Duct Type



# Installation Instructions

### Required tools for Installation Works

1. Philips screw driver	7. Reamer	14. Torque wrench
2. Level gauge	8. Knife	18 N•m (1.8 kgf.m)
3. Electric drill, hole core drill (ø70 mm)	9. Gas leak detector	42 N•m (4.2 kgf.m)
4. Hexagonal wrench (4 mm)	10. Measuring tape	15. Vacuum pump
5. Spanner	11. Thermometer	16. Gauge manifold
6. Pipe cutter	12. Megameter	
	13. Multimeter	

### SAFETY PRECAUTIONS

- Read the following "SAFETY PRECAUTIONS" carefully before installation.
- Electrical work must be installed by a licensed electrician. Be sure to use the correct rating of the power plug and main circuit for the model to be installed.
- The caution items stated here must be followed because these important contents are related to safety. The meaning of each indication used is as below. Incorrect installation due to ignoring of the instruction will cause harm or damage, and the seriousness is classified by the following indications.



	<b>WARNING</b>	This indication shows the possibility of causing death or serious injury.
	<b>CAUTION</b>	This indication shows the possibility of causing injury or damage to properties only.

The items to be followed are classified by the symbols:

	Symbol with background white denotes item that is PROHIBITED from doing.
---	--

- Carry out test running to confirm that no abnormality occurs after the installation. Then, explain to user the operation, care and maintenance as stated in instructions. Please remind the customer to keep the operating instructions for future reference.

### WARNING

- 1) Engage dealer or specialist for installation. If installation done by the user is defective, it will cause water leakage, electrical shock or fire.
- 2) Install according to this installation instruction strictly. If installation is defective, it will cause water leakage, electrical shock or fire.
- 3) Use the attached accessories parts and specified parts for installation. Otherwise, it will cause the set to fall, water leakage, fire or electrical shock.
- 4) Install at a strong and firm location which is able to withstand the set's weight. If the strength is not enough or installation is not properly done, the set will drop and cause injury.
- 5) For electrical work, follow the local national wiring standard, regulation and this installation instruction. An independent circuit and single outlet must be used. If electrical circuit capacity is not enough or defect found in electrical work, it will cause electrical shock or fire.
- 6) Use the specified cable (1.5 mm<sup>2</sup>) and connect tightly for indoor/outdoor connection. Connect tightly and clamp the cable so that no external force will be acted on the terminal. If connection or fixing is not perfect, it will cause heat-up or fire at the connection.
- 7) Wire routing must be properly arranged so that control board cover is fixed properly. If control board cover is not fixed perfectly, it will cause heat-up at connection point of terminal, fire or electrical shock.
- 8) When carrying out piping connection, take care not to let air substances other than the specified refrigerant go into refrigeration cycle. Otherwise, it will cause lower capacity, abnormal high pressure in the refrigeration cycle, explosion and injury. 
- 9) When connecting the piping, do not allow air or any substances other than the specified refrigerant (R410A) to enter the refrigeration cycle. Otherwise, this may lower the capacity, cause abnormally high pressure in the refrigeration cycle, and possibly result in explosion and injury. 
- 10) Do not modify the length of the power supply cord or use of the extension cord, and do not share the single outlet with other electrical appliances. Otherwise, it will cause fire or electrical shock. 













### CAUTION

- 1) This equipment must be earthed. It may cause electrical shock if grounding is not perfect.
- 2) Do not install the unit at place where leakage of flammable gas may occur. In case gas leaks and accumulates at surrounding of the unit, it may cause fire. 
- 3) Carry out drainage piping as mentioned in installation instructions. If drainage is not perfect, water may enter the room and damage the furniture.

### ATTENTION

- 1) Selection of the installation location.  
Select a installation location which is rigid and strong enough to support or hold the unit, and select a location for easy maintenance.
- 2) Do not release refrigerant.  
Do not release refrigerant during piping work for installation, reinstallation and during repairing a refrigeration parts. Take care of the liquid refrigerant, it may cause frostbite.
- 3) Installation work.  
It may need two people to carry out the installation work.
- 4) Do not install this appliance in a laundry room or other location where water may drip from the ceiling, etc.

### Indoor Unit Accessory Parts

No.	Accessory part	Qty.	No.	Accessory part	Qty.
1	Piping insulation 	1	7	Drain hose insulation 	1
2	Band 	2	8	Receiver 	1
3	Remote control 	1	9	Receiver cover 	1
4	Battery 	2	10	Receiver mount 	1
5	Remote control holder 	1	11	Clamp 	2
6	Remote control holder fixing screw 	2	12	Clamp mounting screw 	2

#### Required Materials

- Read the catalog and other technical materials and prepare the required materials.

#### Other Items to be Prepared (Locally Purchased)

Product name	Remarks
Rigid PVC pipe	VP20 (outer diameter ø26); also sockets, elbows and other parts as necessary
Adhesive	PVC adhesive
Insulation	For refrigerant piping insulation (foamed polyethylene with a thickness of 8 mm or more) For drain piping insulation (foamed polyethylene with a thickness of 10 mm or more)
Indoor/outdoor connecting cable	4 × 1.5 mm <sup>2</sup> flexible cord, type designation 245 IEC 57 (H05RN-F)
Hanging bolt related parts	Hanging bolts (M10) (4) and nuts (12), Flat washers (8) (when hanging the indoor unit)

## 1 Selecting the Installation Location

Take into consideration the following contents when creating the blueprint.

#### Indoor unit installation location

- The location should be strong enough to support the main unit without vibration.
- There should not be any heat or steam sources nearby.
- Drainage should be easy. Avoid locating the drain port close to ditches (domestic wastewater).
- Avoid locations above entrances and exits.
- Do not block the intake and discharge.
- Select the location so that the cool and warm air spreads throughout the entire room.
- Locate the indoor unit at least 1 m or more away from a TV, radio, wireless equipment, antenna cables and fluorescent lights, and 2 m or more away from a telephone.

Note that if the air conditioning unit is installed near an electronically lit fluorescent light (inverter, rapid start type, etc.), it may not receive the remote control signals.

#### Remote control mounting location

- Signals may not be transmitted and received correctly when the remote control is operated while in the holder. Take the remote control in your hand to operate the unit.
- Mount the holder in a location that is not subject to the effects of heat (direct sunlight and stoves, etc.).

#### Attaching the remote control holder to the wall

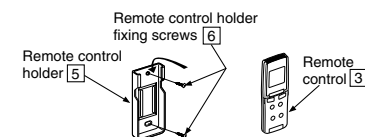

## 2 Selecting the Piping

- Prepare the piping set shown in the table below or equivalent products for the refrigerant piping.

Liquid side	ø 6.35 (1/4") t 0.8
Gas side	ø 9.52 (3/8") t 0.8

\* See the Outdoor Unit Installation Instructions.

## 3 To Drill a Hole in the Wall and Install a Sleeve of Piping

- Insert the piping sleeve to the hole.
- Fix the bushing to the sleeve.
- Cut the sleeve until it extrudes about 15 mm from the wall.

#### CAUTION

When the wall is hollow, please be sure to use the sleeve for tube ass'y to prevent dangers caused by mice biting the connecting cable.

- Finish by sealing the sleeve with putty or caulking compound at the final stage.

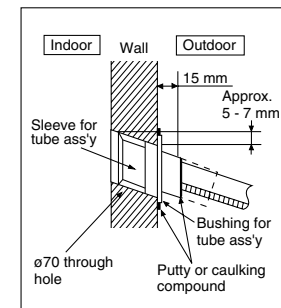

## 4 Installing the Indoor Unit (Installation embedded in the ceiling)

- Always provide sufficient entry and exit space to allow installation work, inspection and unit replacement.
- Waterproof the rear surface of the ceiling below the unit in consideration of water droplets forming and dropping.

### CAUTION

When cooling operation is performed for an extended period under the following conditions, water droplets may form and drop. Attach locally purchased insulation (foamed polyethylene with a thickness of 5 mm or more) to the outside of the indoor unit before installation within the ceiling for improving the heat insulation.

- Locations with a dew point inside the ceiling of 23 C or more
- Kitchens and other locations that produce large amounts of heat and steam
- Locations where the inside of the ceiling serves as an outside air intake passage

- When installing within a ceiling, select the unit position and the airflow direction so that the cool air and warm air spread throughout the whole room.
- Do not place objects that might obstruct the air flow within 1 m below the intake grille.

### Ceiling Opening and Hanging Bolt Locations

- The relative positions of the ceiling opening and the hanging bolts are shown in the illustration to the right. When making an inspection opening below the unit, make a 960 mm × 480 mm opening in the ceiling surface. Also, lead the drain piping, refrigerant piping and indoor/outdoor connecting cable up to the respective piping and cable connection positions.
- Secure the hanging bolts (M10, Locally Purchased) firmly in a manners capable of supporting the unit weight.
- Consult your construction or interior contractor for details on finishing the ceiling opening.

### Preparing to Install the Indoor Unit

- Fit the drain hose insulation [7] around the drain hose as shown in the right figure.
- Attach the discharge chamber. (※) (10 screws)
- Cut out the intake cut-out portions in the unit rear panel using cutter or other tools to make openings.
- Remove the two screws at the rear edge of the unit top panel, and attach the intake chamber. (※) (8 screws)

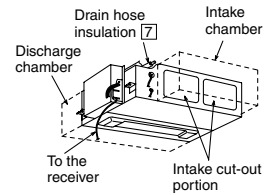

(View from below and behind the unit)

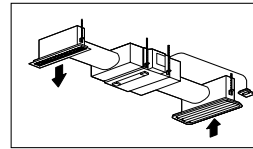

### Installation Diagram

This diagram shows the unit together with the purchased components.

(This shows an installation example.)

Installing an Intake and Discharge Duct Type		
	Allowable duct length	Duct bends
Discharge side duct	5 m or less including the intake side	90° or less in one location
Intake side duct	1 m or less	45° or less in one location

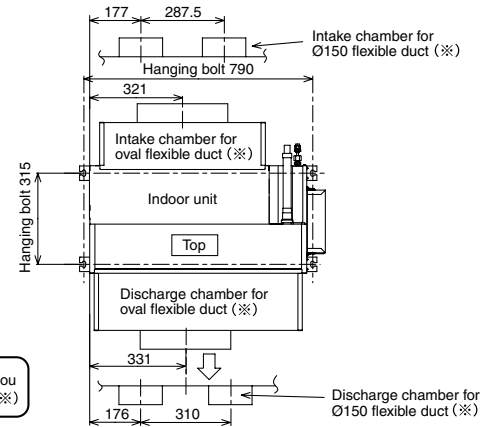

Top view (from above the ceiling)

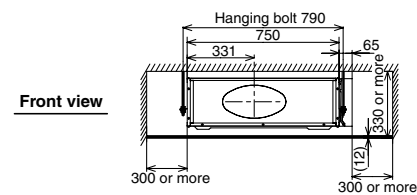

Front view

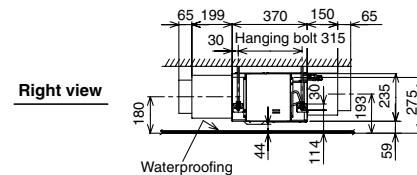

Right view

**Securing the Hanging Bolts**

**Reinforced concrete**  
(Unit: mm)

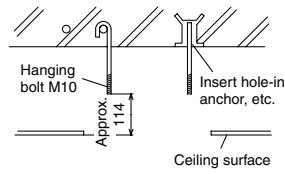

**Wooden or other structure**  
(Unit: mm)

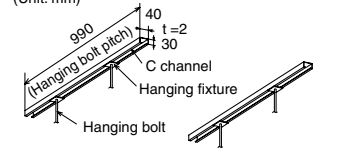

**Switching the high state switch (SW2)**

- To increase the air volume, open the control box and on the control board switch the high state switch (SW2) to "HI".
- See the diagram for "Connecting the Indoor/ Outdoor Connecting Cable".

**Installation in the Ceiling**

- Attach the nuts and washers to the hanging bolts, then lift up and hook the main unit onto the hanging fixtures.
- Check that the unit is level using a level or a vinyl hose filled partially with water.

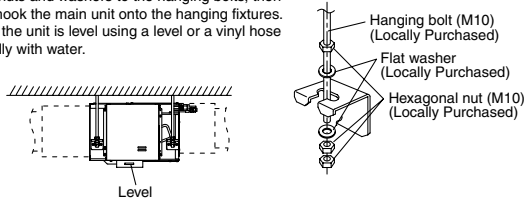

**Mounting the Receiver**

- Select a ceiling or wall position that does not block reception for the mounting location. Note that the receiver cord is 2.0 m.
- First hook the clamps [11] onto the receiver mount [10] as shown in the figure below, then partially tighten the mounting screws [12].
- Fit the receiver [8] into the receiver mount [10] so that the locking hooks are firmly engaged.
- Fit the above mounts into the ceiling or wall opening, and tighten the screws [12] until the clamps [11] firmly clasp the ceiling or wall materials.
- Attach the receiver cover [9] so that the hooks on the inside are firmly hooked onto the receiver mount [10].
- Lead the receiver cord and connect it to the control box.

**Mounting Section View**

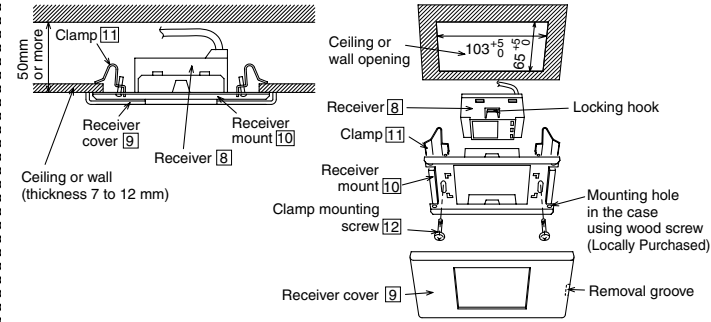

## 5 Connecting the Drain Piping

- Lay the drain piping so as to ensure drainage.
- Use a locally purchased VP20 general rigid PVC pipe (outer diameter  $\phi 26$ ) for the drain piping, and firmly connect the indoor unit and the drain piping using PVC adhesive to ensure that there is no leakage.
- Drain piping located indoors should always be insulated by wrapping with locally purchased insulation (foamed polyethylene with a thickness of 10 mm or more).
- The drain piping should have a downward gradient (1/50 or more), and should be secured using pipe hanging equipment to avoid creating hills or traps partway.

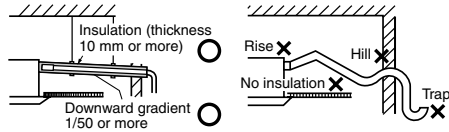

- Should some obstacle prevent the drain piping from being extended smoothly, the drain piping can be raised outside the main unit as shown in the illustration below.

### CAUTION

Absolutely do not install and extend the drain piping from the main unit drain water outlet horizontally or upward or raise it 20cm or more. Doing so may result in poor drainage or cause of drain motor failure.

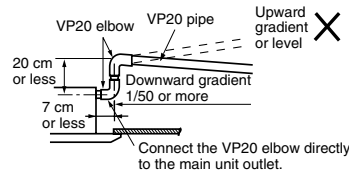

### Check the Drainage

#### Check after connecting the power supply.

- Pour approximately 600 cc of water into the drain pan of the main unit using a squeeze bottle, etc.
- Press the drain test run switch located on the control board of the control box to start the drain motor, and check that the water drains normally. (The drain motor operates for approximately 5 minutes and then stops automatically.) (See the diagram for "Connecting the Indoor/Outdoor Connecting Cable".)

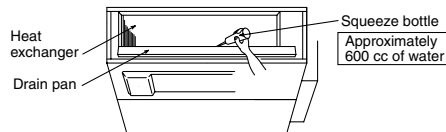

## 6 Connecting and Insulating the Refrigerant Piping

- Align the center of the half-union and the connection pipe and tighten the flare nut by hand, then tighten with a torque wrench.

Pipe diameter	Tightening torque
Liquid side $\phi 6.35$ (1/4")	18N • m (1.8 kgf • m)
Gas side $\phi 9.52$ (3/8")	42N • m (4.2 kgf • m)

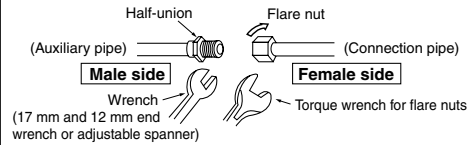

- After the piping is connected, insulate as shown in the illustration below.

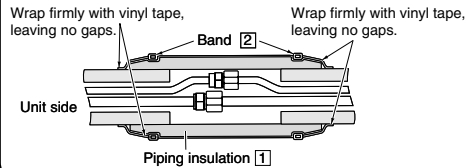

## 7 Connecting the Indoor/Outdoor Connecting Cable

- Remove the control box cover and lead the connecting cable into the control box.
- Check the colors of the wires on the terminal board, and secure them with screws.
- Secure the outer sheath of the connecting cable with the cord clamp.
- Reattach the control box cover in its original position.

### CAUTION

When connecting the connecting cable, provide approximately 40 cm of extra length near the unit to facilitate servicing of electrical parts.

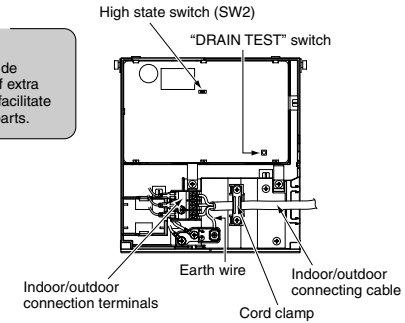

- Connecting cable between indoor unit and outdoor unit shall be approved polychloroprene sheathed  $4 \times 1.5 \text{ mm}^2$  flexible cord, type designation 245 IEC 57(H05RN-F) or heavier cord.
- Ensure the color of wires of outdoor unit and the terminal Nos. are the same to the indoor's respectively.
- Earth lead wire shall be longer than the other lead wires as shown in the figure for the electrical safety in case of the slipping out of the cord from the anchorage.

Terminals on the indoor unit	1	2	3	
Color of wires				
Terminals on the outdoor unit	1	2	3	

- Secure the cable onto the control board with the holder (clammer).

### AUTO SWITCH OPERATION

The below operations will be performed by pressing the "AUTO" switch.

- 1. AUTO OPERATION MODE**  
The Auto operation will be activated immediately once the "AUTO" switch is pressed.
- 2. TEST RUN OPERATION (FOR PUMP DOWN/SERVICING PURPOSE)**  
The Test Run operation will be activated if the "AUTO" switch is pressed continuously for more than 5 sec. to below 8 sec.. A short beep sound will occur at the fifth sec., in order to identify the starting of Test Run operation.

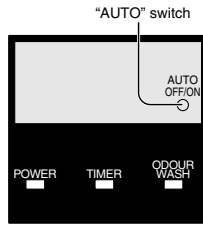

### Changing the remote control transmission code

- When installing two air conditioners in one room, each air conditioner can be synchronized to the remote control. In order to operate separately, open the rear cover of one of the remote control and set to "B".

Set "B" on the remote control. This can be achieved by cutting the jumper wire of the remote control with a cutter.

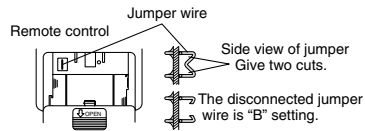

Setting the air conditioner unit to "B"

- Press the "AUTO" switch for about 11 to 15 seconds. When you hear three short beeps release the switch.  
Note: you will hear one short beep in about 5 seconds, and then two short beeps in about 8 seconds.
- Press again the "AUTO" switch within 60 seconds. Every press the "AUTO" switch, you will hear a short beep. When you hear eventually a long beep, stop pressing the "AUTO" switch, which achieves "B" setting.  
If you stop pressing the "AUTO" switch midway at the short beep, this will achieve "A" setting.
- After 60 seconds or longer of the above setting, use the "B" set remote control to confirm successful operation.

### CHECK ITEMS

- |  |   |
|--|---|
| <input type="checkbox"/> Is there any gas leakage at flare nut connections?                | <input type="checkbox"/> Is the earth wire connection properly done?            |
| <input type="checkbox"/> Has the heat insulation been carried out at flare nut connection? | <input type="checkbox"/> Is the power supply voltage complied with rated value? |
| <input type="checkbox"/> Is the connecting cable being fixed to terminal board firmly?     | <input type="checkbox"/> Is there any abnormal sound?                           |
| <input type="checkbox"/> Is the connecting cable being clamped firmly?                     | <input type="checkbox"/> Is the cooling / heating operation normal?             |
| <input type="checkbox"/> Is the drainage ok? (Refer to "Check the drainage" section)       | <input type="checkbox"/> Is the thermostat operation normal?                    |
|  | <input type="checkbox"/> Is the remote control's LCD operation normal?          |

MATSUSHITA ELECTRIC INDUSTRIAL CO., LTD.

Web Site : <http://www.panasonic.co.jp/global/>

ENGLISH

F612425

PRINTED IN JAPAN



# 11 Operating Instructions

## Contents

---

### SAFETY PRECAUTION

---

#### BEFORE OPERATION

- Selection of easy operating modes  
(Automatic operation / Heating / Cooling / Dry /  
Air circulation operation)

---

#### POINTS TO NOTE

- Names of parts and preparations  
(Indoor unit)
- Fan speed / Air Swing Adjustment

---

#### HELPFUL INFORMATION

- Care and maintenance
- Troubleshooting (Self diagnosis)
- Helpful Information

NOTE

**For details about the following items, carefully read the operating instructions attached at the outdoor unit for model CS-ME7CKPG.**

#### SAFETY PRECAUTION

- Installation precautions
- Operation precautions

#### POINTS TO NOTE

- Names of parts and preparations  
(Outdoor unit / Remote control)
- Operational setup

#### CONVENIENCE OPERATIONS

- Powerful operations / Quiet operations
- Timer setting / Sleep Timer Mode
- Odour wash mode

#### HELPFUL INFORMATION

- Inspections and maintenance
- Troubleshooting (Except for “Self diagnosis”)

# Convenience Operation

**Automatic operation • Heating • Cooling • Dry • Air circulation operation**



**WHEN IT IS COLD**



**WHEN IT IS HOT**



**WHEN IT IS HUMID**



**WHEN HEATING / COOLING / DRY ARE NOT REQUIRED**

**1** After connecting the power supply, press  button to select operating mode

Display in the remote control

HEAT  
Or  
AUTO

COOL  
Or  
AUTO  
Or  
DRY

DRY

FAN

Continuously pressing the button, operation changes in this order:

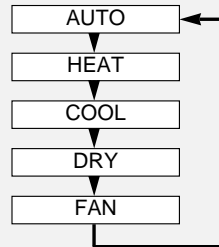

**2** Press  button

- The operation light on the indoor unit will light up.
- During Auto operation / Heating operating mode, the operation light will light up.
- During Heating / Cooling / Dry operating mode, you may not get an instant air flow.

**TO STOP OPERATION**

Press one more time.

Please also refer to "Fan speed / Air swing Adjustment" chapters.

## SETTING TEMPERATURE

DECREASE  TEMP  INCREASE

- Setting range: 16 ~ 30°C
- Each press on the button will change by 1°C. Continuously pressing the button will speed up the changes.

**RECOMMENDED TEMPERATURE**  
 Select suitable temperature will save electricity consumption.

Heating : 20 ~ 22°C  
 Cooling : 26 ~ 28°C  
 Dry : 22 ~ 26°C

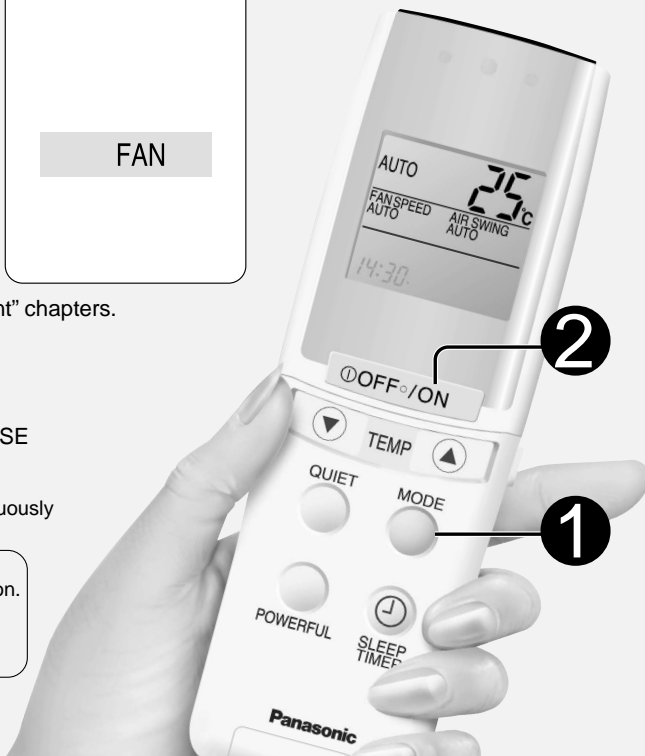

# Names of Parts and Preparations

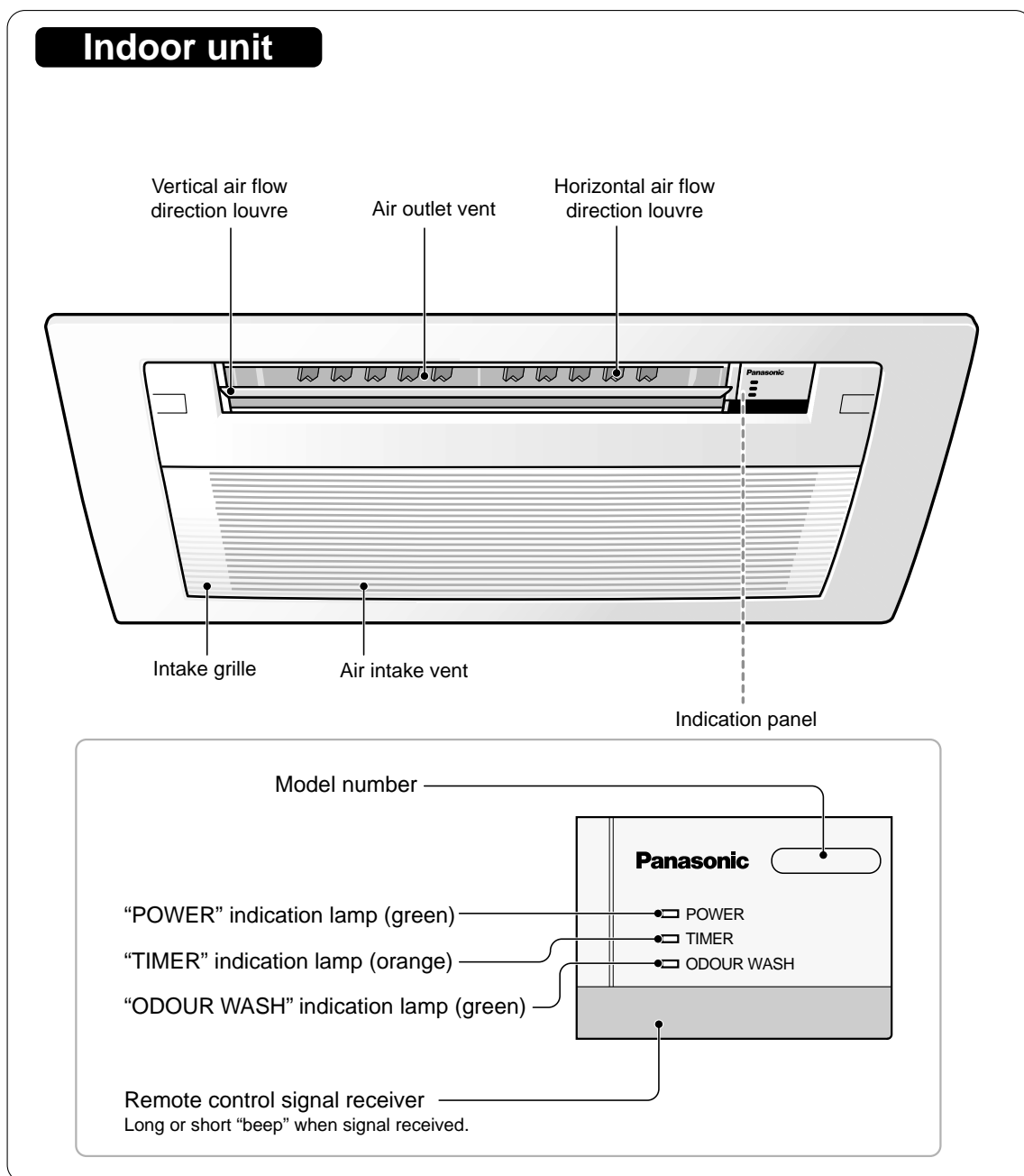

## Auto Restart Control

- If there is a power failure, operation will be automatically restarted under the previous operation mode and air flow direction when power is resumed. (When the operation is not stopped by remote control.)
- If you do not want the unit to restart automatically when power is resumed, switch off the main power supply.
- Auto Restart Control is not available when Timer or Sleep mode is set or the dry mode timer is cancelled.

**Cassette Type**

**■ When the intake grille is open**

**To open**

Press in the 3 places shown.

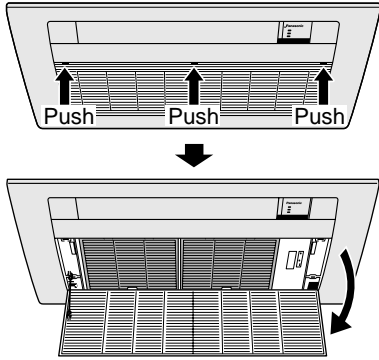

**To close**

Press in the 3 places shown.

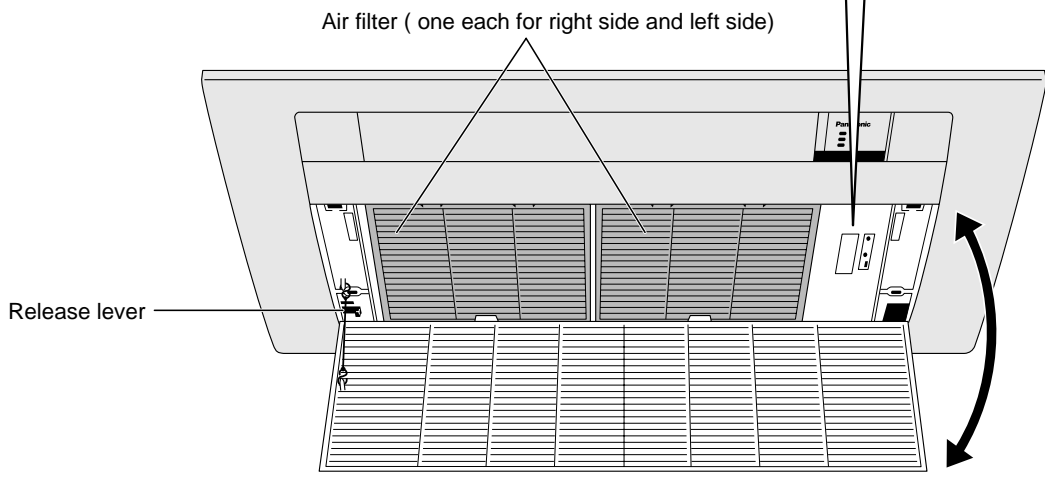
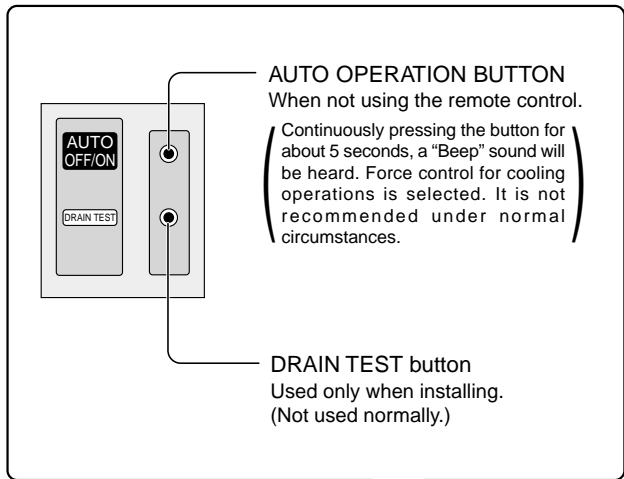
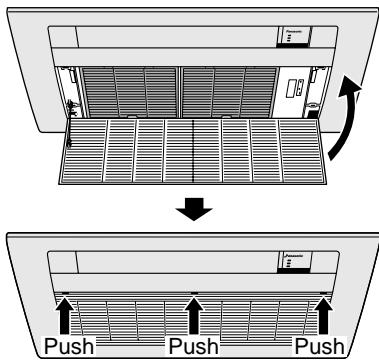

# Names of Parts and Preparations

Duct Type

## Indoor unit

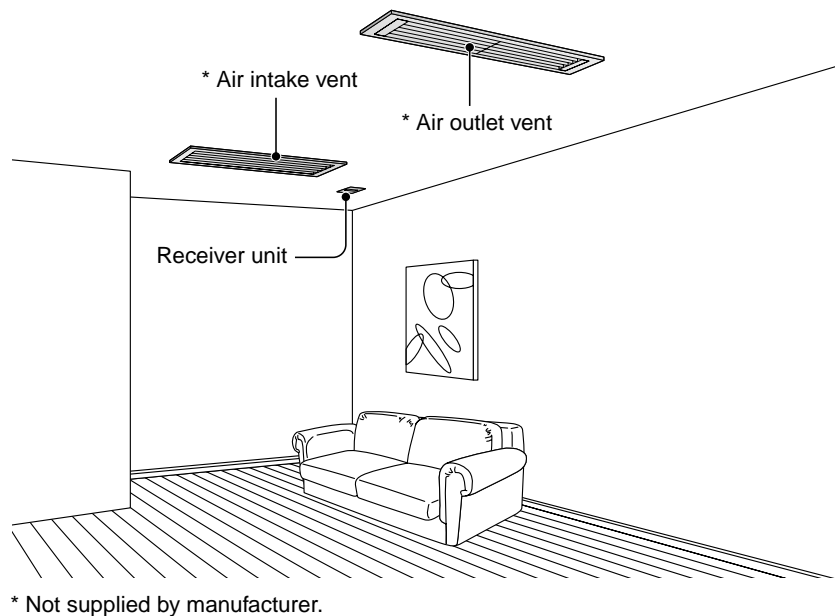

### Receiver unit

Remote control signal receiver  
Long or short "beep" when signal received.

"POWER" indication lamp (green)  
"TIMER" indication lamp (orange)  
"ODOUR WASH" indication lamp (green)

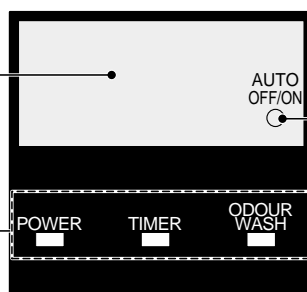

AUTO OPERATION BUTTON  
When not using the remote control.

(Continuously pressing the button for about 5 seconds, a "Beep" sound will be heard. Force control for cooling operations is selected. It is not recommended under normal circumstances.)

### Auto Restart Control

- If there is a power failure, operation will be automatically restarted under the previous operation mode and air flow direction when power is resumed. (When the operation is not stopped by remote control.)
- If you do not want the unit to restart automatically when power is resumed, switch off the main power supply.
- Auto Restart Control is not available when Timer or Sleep mode is set or the dry mode timer is cancelled.

# Fan Speed / Air Swing Adjustment

## Changing the fan speed

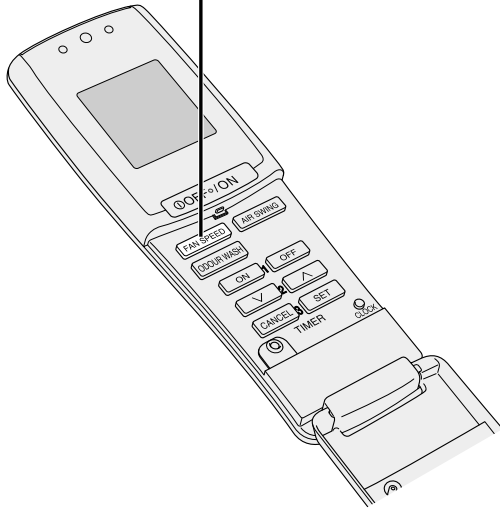

Press **FAN SPEED**

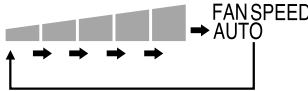
- You may select from 5 stages of fan speed apart from the auto fan speed.
- Continuously pressing:
 

The indication will change accordingly.  
The increase in size of indication indicates higher fan speed.



Low ← High

- During DRY mode, should the room temperature is higher than the remote control set temperature, the fan speed will be running to that set by the remote control. Whenever the room temperature approaches the set temperature level, the fan speed will be running in the Low fan speed regardless of the indication.

**■ AUTOMATIC FAN SPEED**

**HEATING:**  
Fan speed will be running in the Low fan speed when the air temperature is low. Fan speed will be running in the High fan speed when the air temperature is high.

**COOLING / DRY:**  
During COOLING mode, adjust the fan speed to create cool air flow.  
The air flow will be delayed for 40 seconds during the start of operations under the COOLING / DRY modes. Furthermore, sometimes there may be air flow cut off during operation. Read the instructions for the wall-mounted type (CS-ME7CKPG). (Page 22)

## Changing the vertical air flow directions

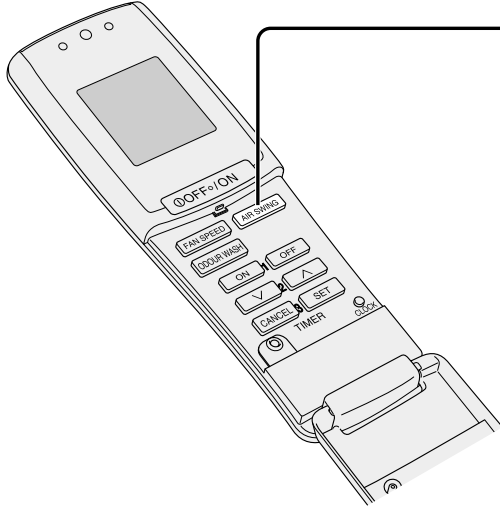

Press **AIR SWING**

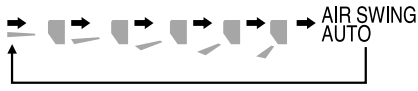
- You may select from 5 stages of air flow direction apart from the auto air swing.
- Continuously pressing:
 

The indication will change accordingly  
(The indications are just air flow direction guidelines, which may differ with the actual indoor unit louvre positions and angles)

**NOTE**

- You cannot change the air flow direction on the duct type.

# Fan Speed / Air Swing Adjustment

## Vertical air flow direction

### ■ Setting automatic air flow directions

#### HEATING

During starting of operations and other circumstances when the air temperature is low, the air flow blows horizontally.

When temperature is high, air flow is blown down, then it starts swinging.

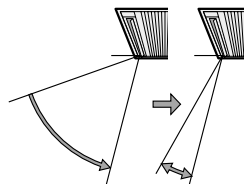

#### COOLING • DRY • AIR CIRCULATION

Automatically it sets to swing up and swing down.

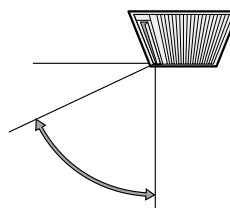

- Adjust the vertical air flow directions by only using the remote control. (To prevent mistakes, condensation and damage)
- At the end of operation, the louvres will automatically close up the air flow outlet vents.
- The louvres will automatically adjust its air flow angles to prevent condensation (during COOLING / DRY) and cold air blowing out (during HEATING).
- The louvres adjustment range during HEATING and COOLING / DRY may not be the same.

#### Louvres adjustment angles

You can adjust the louvres in 5 steps within these ranges.

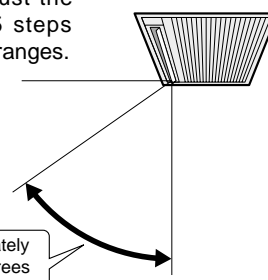

#### NOTE

- You cannot change the air flow direction on the duct type.

## Horizontal air flow direction

- Manually grip and move the horizontal air flow louvres.
- The blower fan of the indoor unit is operating at a high speed, hence, be careful not to insert your fingers into the portion behind the louvres.

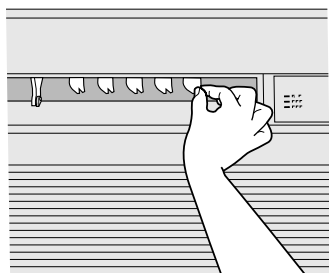

#### NOTE

- You cannot change the air flow direction on the duct type.

# Care and maintenance

Cassette Type

## ⚠ Caution

■ Ensure that the operation is stopped, power supply is off before you do the air conditioner cleaning.

The internal high speed fan may cause injuries.

■ Ensure that you are on firm footing before attempting to repair or service the air conditioner.

The unit in operation may cause injuries.

## Cleaning the air filter (about once every one and a half months)

**1** Press in the 3 places shown to open the intake grille.

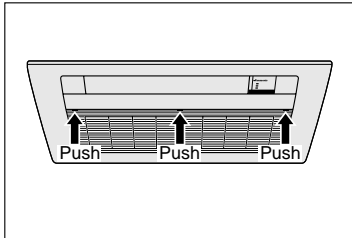

**2** Remove the air filter

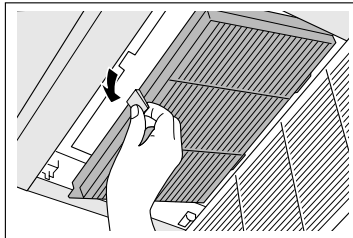

Grasp the tab and pull down.

**3** Suck up the dust and dirt by a vacuum cleaner

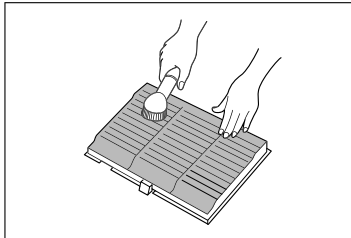

For stubborn dirt and grime, apply mild kitchen detergent (neutral type) and rinse with water. Leave it to dry in the sun. (Avoid drying them near the stove or electric dryer)

**4** Installing the air filter

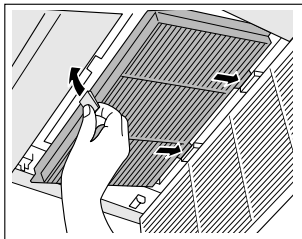

Insert the tabs into the slots and push up.

**5** Press in the 3 places shown to close the intake grille.

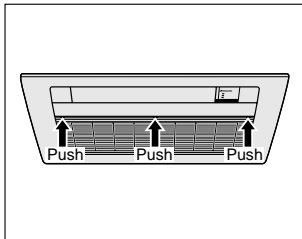

### NOTE

- If the filters are being used over an extended period of time without timely servicing, their performance may decrease and foul odour may build up.
- The maintenance period may be used as a criterion. However, if operating conditions cause build up of odours, you need to service it as soon as possible.

### ITEMS SOLD SEPARATELY

PART NAME	PART NUMBER
Air filter	CWD00228



# Care and maintenance

Cassette Type

## Cleaning the intake grille (Must be removed from unit before washing)

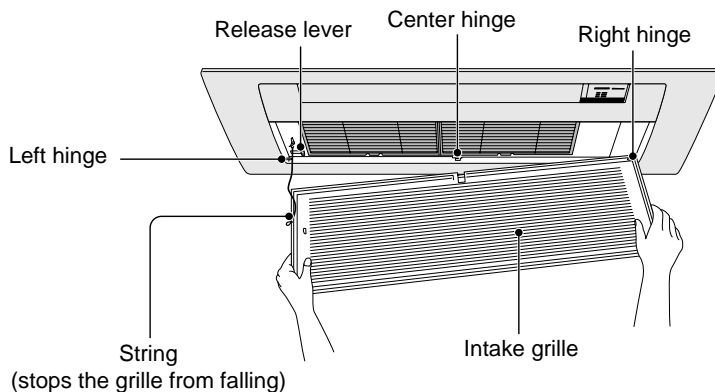

### 1 Raise the intake grille (Keep hold of the intake grille when detaching it.)

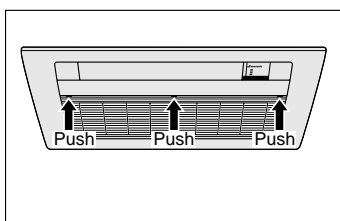

Press in the 3 places shown to open the intake grille.

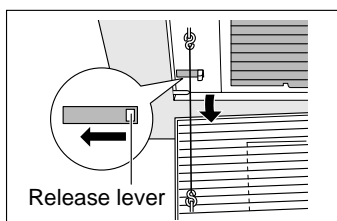

Hold onto the intake grille and slide the release lever to release the hinge.

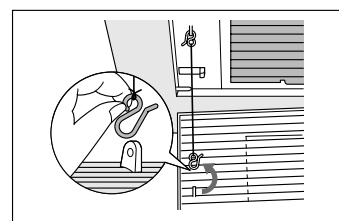

Release the string from the intake grille.

### 2 Wash and dry the intake grille

Cleanse with a soft cloth and sponge.

Then, wipe dry the excess moisture and leave the panel to dry in the shade.

- Avoid pressing hard on the surface and avoid the use of a hard brush. (To prevent injuries)
- Apply some mild kitchen detergent (neutral type) to wash off stubborn dirt and grime.
- Avoid drying the panel in direct sunlight or over a stove. (May cause color fading and structural distortions)

### 3 To fix the intake grille

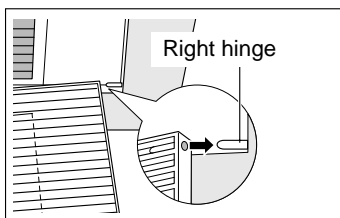

Fit the grille to the hinge on the right of the main unit.

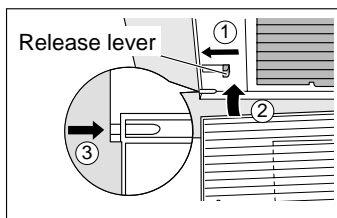

Slide and hold the release lever in place, then fit the grille into place and release the lever.

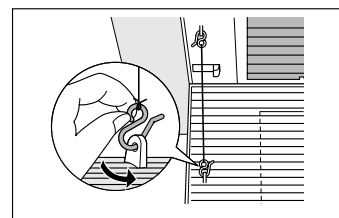

Attach the string to the grille, then press in the 3 places (shown in the first illustration in step 1) to close the intake grille.

# Troubleshooting

The following symptoms are not faults. Please continue to use it without fear.

## Is it faulty?

There is noise.

## No, it is okay

- Sound of flowing water:
  - Caused by the flow of refrigerant gas through the air conditioner system.
  - Caused by the flow of condensated water by drain pump.

For details about items not covered here, read the operating instructions attached at the outdoor unit for model CS-ME7CKPG.

## Self diagnosis

### Is it okay?

#### ■ The TIMER lamp blinks

##### Cassette Type

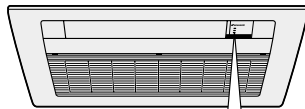

- POWER
- TIMER
- ODOUR WASH

##### Duct Type

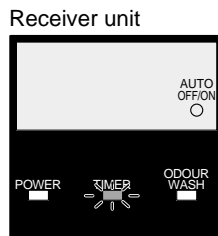

### Consult your dealer

Notify them of all abnormalities. You can self diagnose using the remote control. Follow the instructions below. After confirmation, stop all operations and switch off the power supply.

#### ■ How to self diagnosis

- 1 Press for 5 seconds**
  - 3 alphanumeric digits will appear on the remote control display.

- 2 When the indoor unit gives off a continuous "Beep, Beep, Beep, Beep" sound, slowly and repeatedly press** 
  - Inform your dealer on the displayed 3 alphanumeric digits.

DISPLAYED ALPHANUMERIC DIGITS	
H□□	The H and F (followed by 2 numerals) represent different sets of abnormalities.
F□□	

When H33, H36 and H37 are displayed, you must not operate until repairs have been done.

- H36 : Heating • Air circulation
- H37 : Cooling • Dry • Air circulation

Press for 5 seconds, using the remote control select and operate the Heating • Cooling • Dry • Air circulation modes. (There will be "Beep, Beep, Beep, Beep" sound to confirm the command is received).

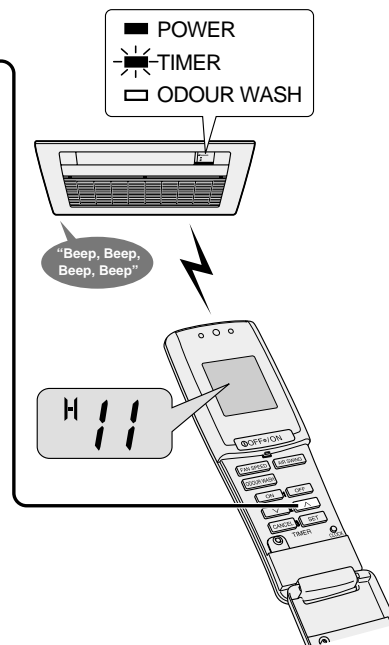

# Helpful Information

## Helpful Information

### ■ When the remote control is not available and the batteries are out.

It is still possible for emergency operations. In this case, the unit will operate on the default temperature of 25°C. Adjustment to the default temperature is not allowed.

- ① Switch on the power supply
- ② Press the auto operation button.

■ To stop operation, press the button once more.

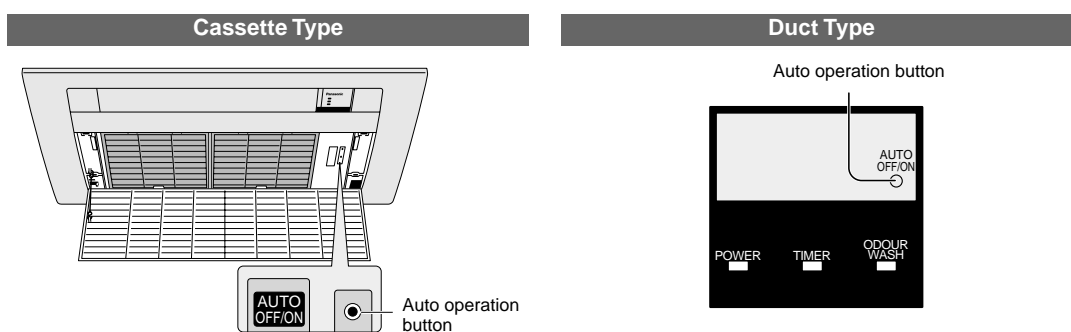

### ■ When there is a power failure

- During operation:  
All operations stopped. When power supply is restored, run operations all over again.
- During preset timer mode:  
The timer mode is cancelled. (The indoor unit TIMER lamp will be off) When power supply is restored, reset TIMER once again.

### ■ When there is thunder in the vicinity:

To avoid lightning strikes, stop all operations and switch off the power supply. (To protect the air conditioner)

### ■ After you have used wax:

Be sure the furniture wax is fully dried before starting the air conditioner.

### ■ Placing things around the indoor unit:

Allow a lot of spacing if you wish to place things around the indoor unit.  
If tall furniture are placed near the unit, it may hinder the air flow which will reduce the efficiency of the unit.

### ■ When the unit is not operated for an extended period of time:

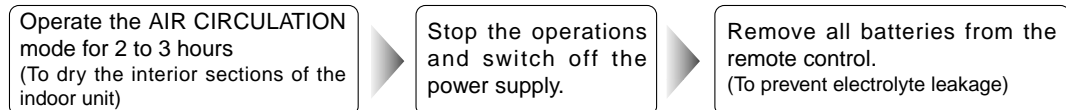

# Safety Precaution

## WARNING

- 1) This appliance must be earthed.
- 2) If the supply cord is damaged or needed to be replaced, it must be replaced by authorized service agent or a similarly qualified person in order to avoid a hazard.
- 3) Remove power plug or disconnect from the main power supply before servicing this appliance.
- 4) Do not repair by yourself.  
In case of malfunction of this appliance, do not repair by yourself.  
Contact to the sales dealer or service dealer for a repair.
- 5) Do not use in an explosive atmosphere.  
Do not use this appliance in a potentially explosive atmosphere.
- 6) Turn off the power (Isolation from main power supply).  
Pull off the power plug from the receptacle, or switch off the breaker, or switch off power disconnecting mean to isolate the equipment from the main power supply in case of an emergency.

\* Airborne noise.  
A-weighted sound pressure level of this appliance is less than 70dB (A) under the JIS C 9612 test conditions.  
Maximum cooling operation 1 m from the unit

### ■ Notes

- If the unit is not going to be used for an extended period of time, turn off the main Power supply. If it is left at the ON position, approximately 14 W of electricity will be used even if the indoor unit has been turned off with the remote control.
- If operation is stopped, then restart immediately, the unit will resume operation only after 3 minutes.

Use under the following conditions								(Unit in °C)	
DBT: Dry Bulb Temp	Cooling				Heating				
	Indoor		Outdoor		Indoor		Outdoor		
WBT: Wet Bulb Temp	DBT	WBT	DBT	WBT	DBT	WBT	DBT	WBT	
Maximum Temperature	32	23	43	26	30	–	24	18	
Minimum Temperature	16	11	16	11	2	–	-5	-6	

## 12 Disassembly of Parts

### 12.1. Cassette Type (Indoor Unit: CS-ME7CB1P/ME10CB1P/ME12CB1P/ME14CB1P)

#### 12.1.1. Detaching the fan motor and cross flow fan

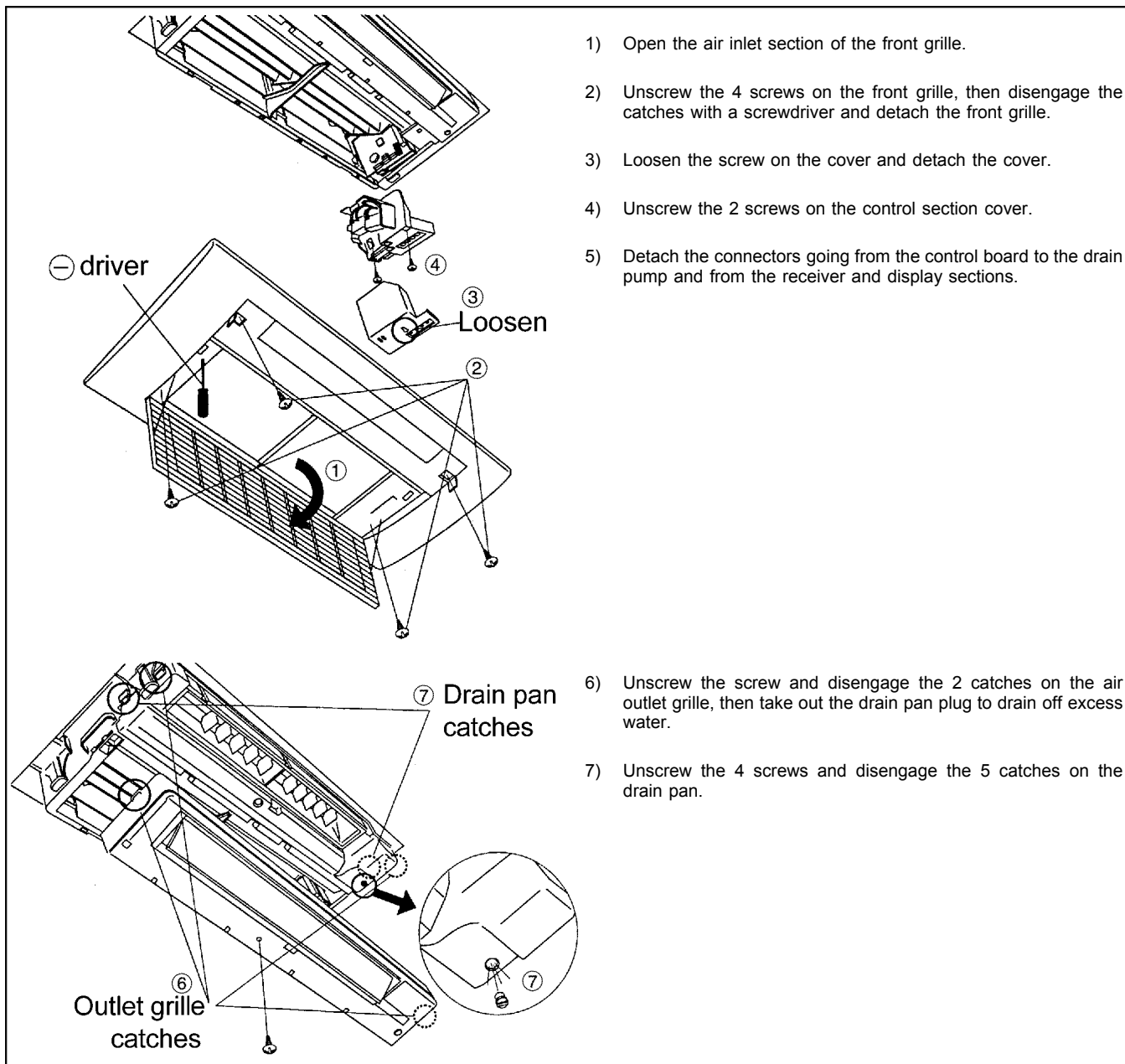

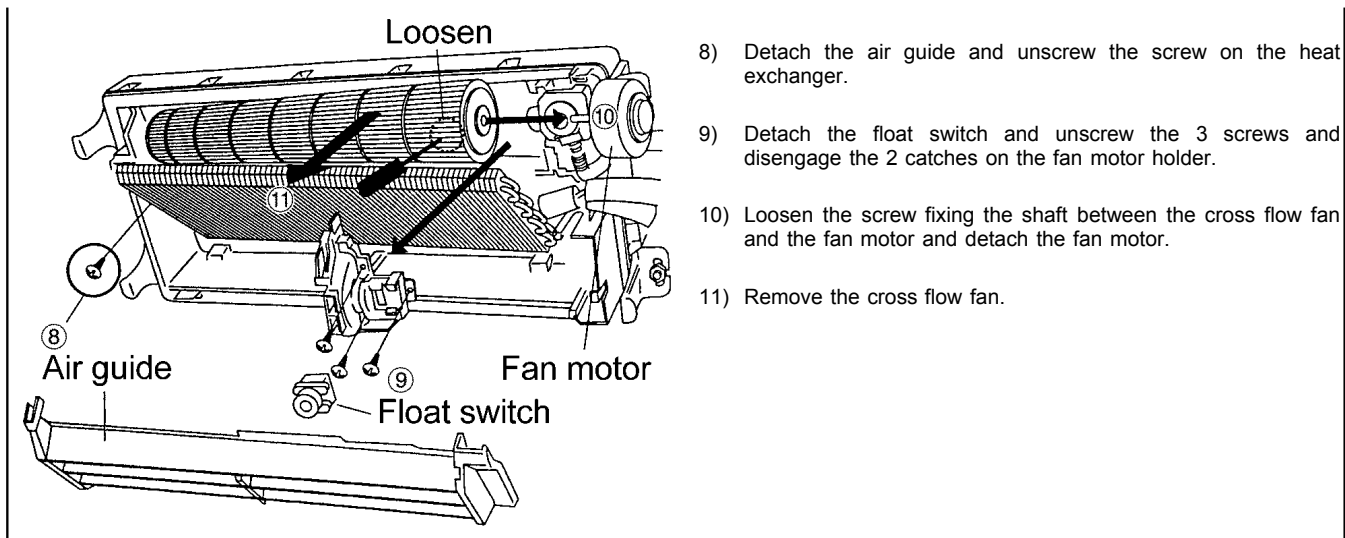

### 12.1.2. Detaching the drain pump

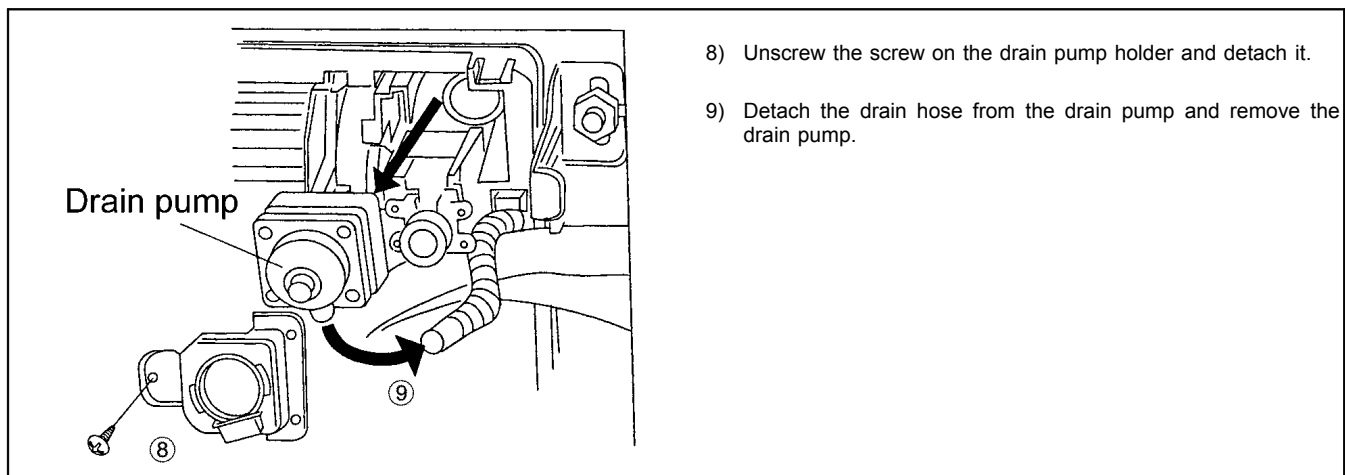

### 12.1.3. Detaching the control board

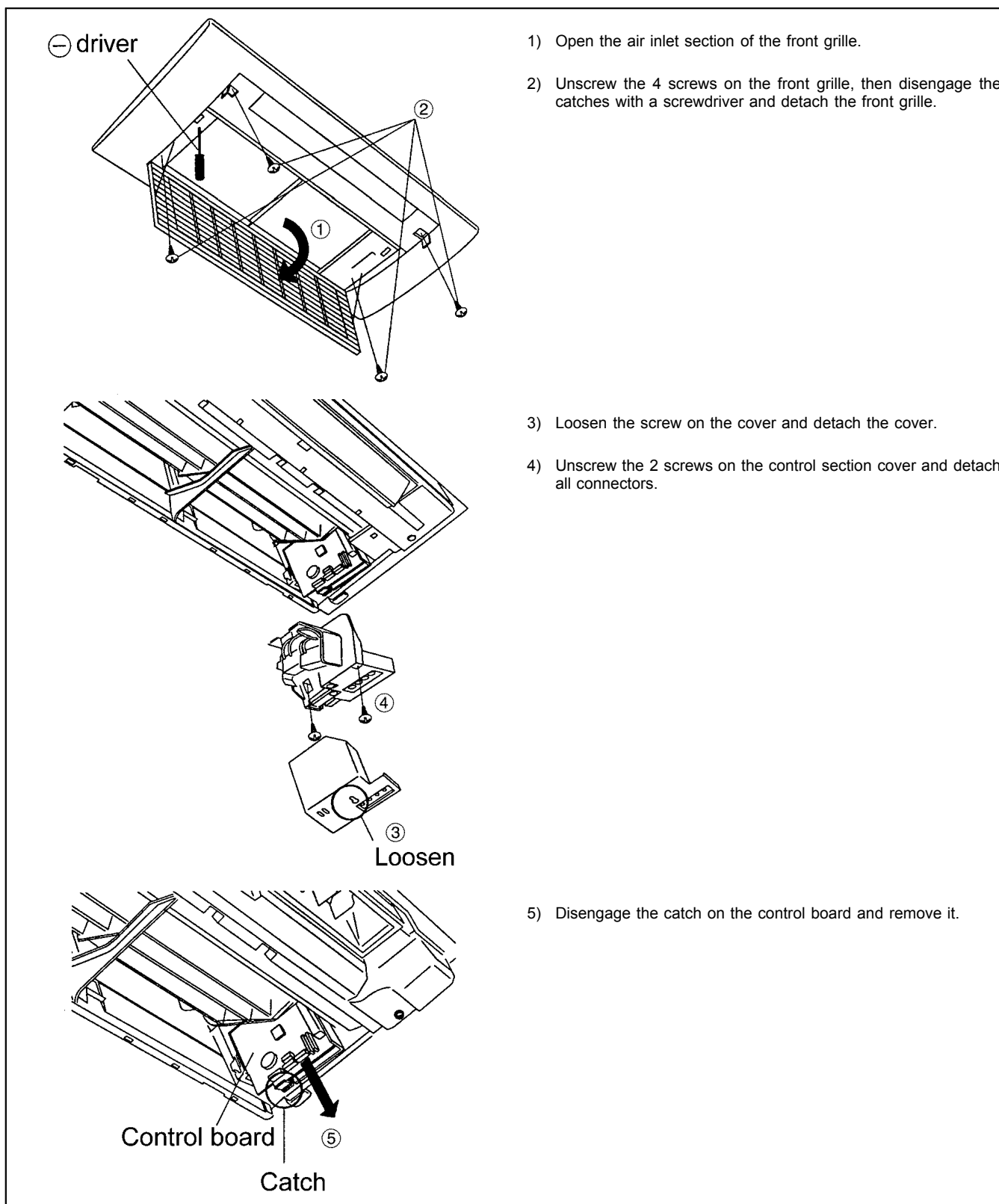

### 12.1.4. Detaching the louver motor

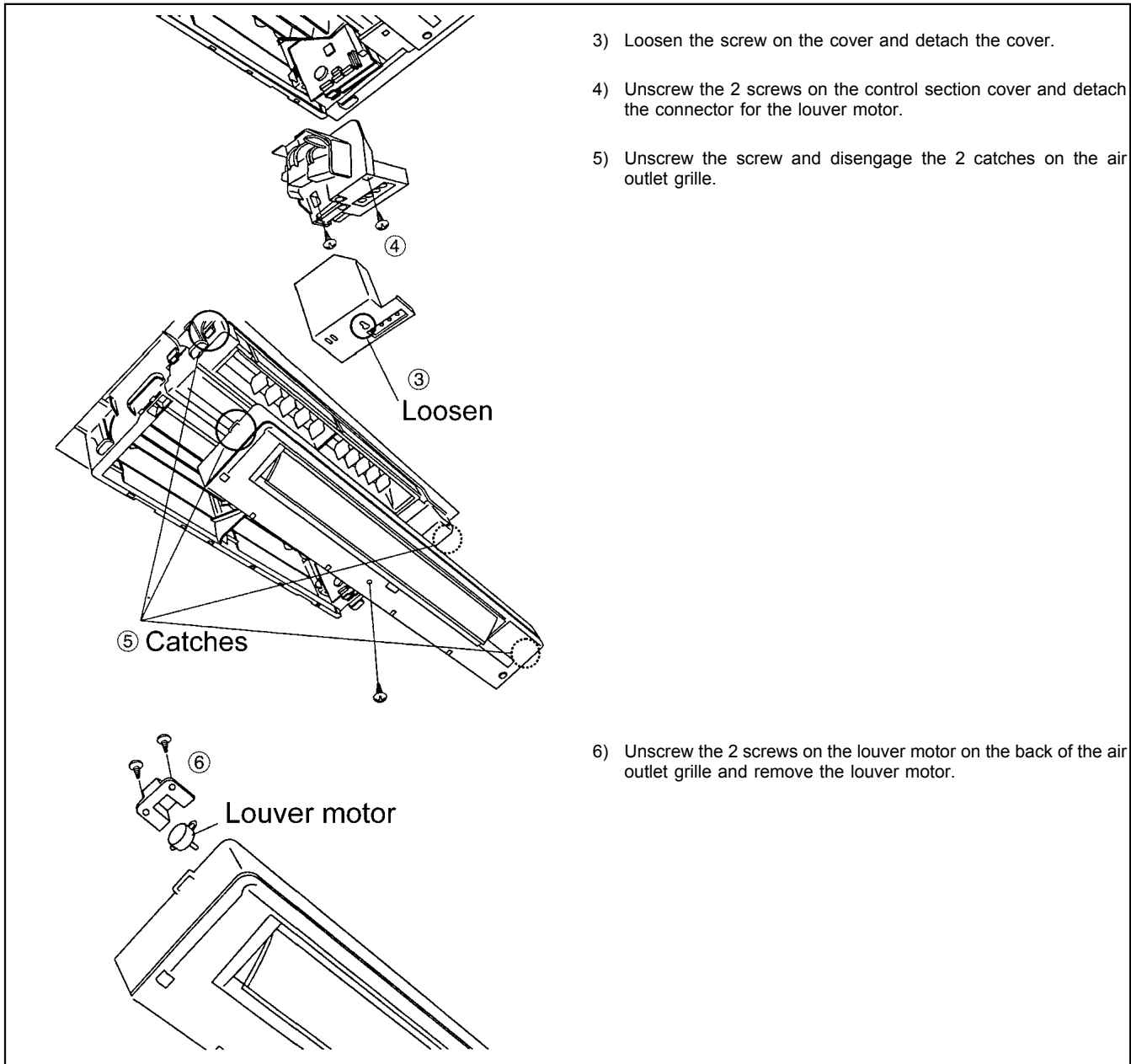



## 12.2. Duct Type (Indoor Unit: CS-ME10CD3P/ME14CD3P)

### 12.2.1. Detaching the upper and inner casing

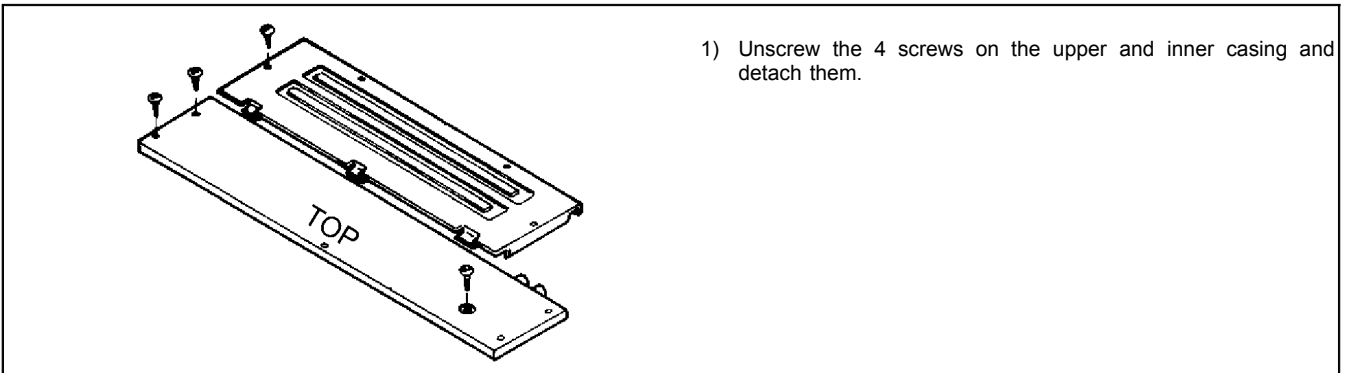

### 12.2.2. Detaching the control board

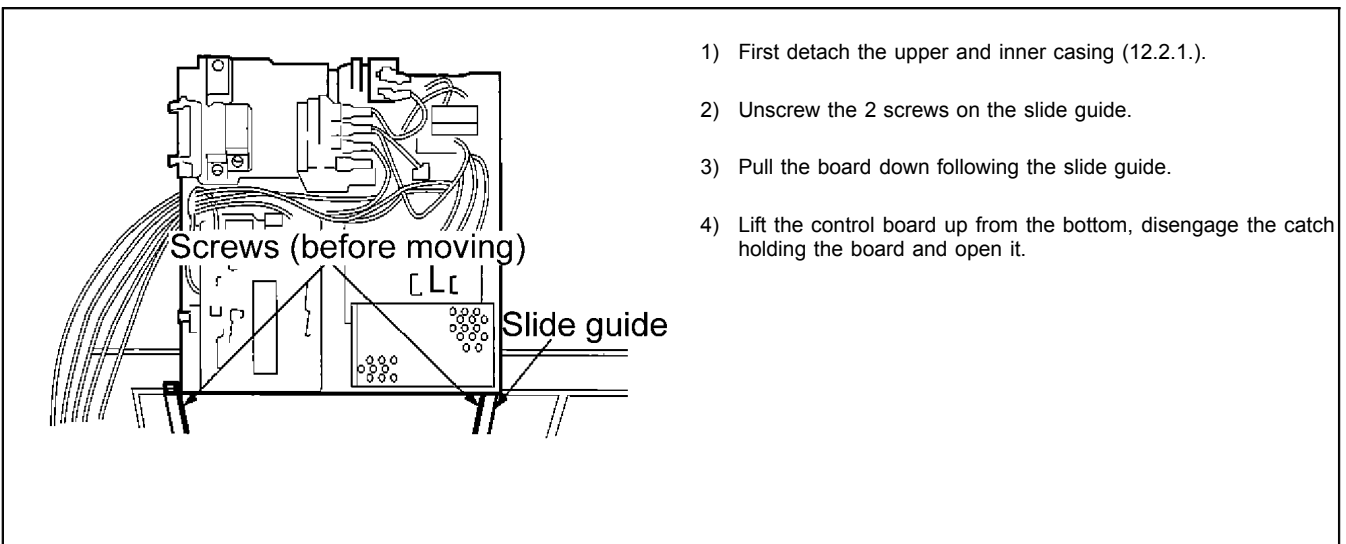

### 12.2.3. Detaching the fan

The diagram illustrates the three steps of detaching the fan. Step 1 shows the upper and lower air guides being separated from the main casing. Step 2 shows the fan motor being released from the casing by disengaging catches on both sides. Step 3 shows the fan blades being detached from the motor shaft by loosening a connecting bolt and a screw that holds the fan in place.

- 1) First detach the upper and inner casing (12.2.1.).
- 2) Disengage the 4 catches (2 each on the left and right) on the air guide.
- 3) Use a 2.5 mm hexagonal wrench to loosen the bolt connecting the fan motor and fan, detach the shaft connecting the fan motor and fan, loosen the screw holding the fan and detach the fan.

### 12.2.4. Detaching the fan motor and drain motor

The diagram shows the internal components of the unit. The drain motor is located at the bottom left, and the fan motor is at the top left. Two hexagon bolts are shown securing the drain motor to the casing. The instructions describe how to remove the fan motor first, then the drain motor by undoing the hexagon bolts.

**Fan motor**

- 1) First detach the upper and inner casing (12.2.1.) and the fan (12.2.3.).
- 2) Unscrew the 4 screws holding the fan motor and detach it.

**Drain motor**

- 1) First detach the upper and inner casing (12.2.1.) and the fan (12.2.3.).
- 2) From the fan motor side, undo the 2 hexagon bolts and detach the drain motor.

# 13 Technical Data

## 13.1. OPERATION CHARACTERISTICS

### CU-3E23CBPG (one room operation)

Cooling characteristics and outdoor temperature  
Operating conditions\*: Room 27°C, fan on HIGH

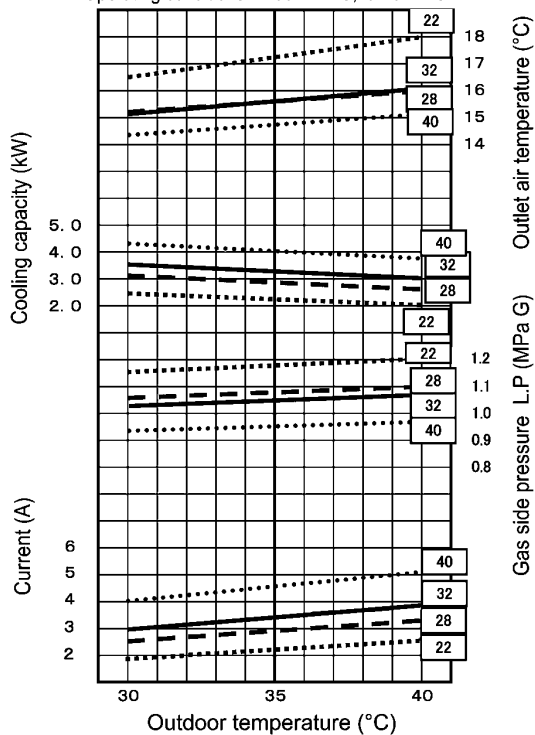

\* 22:17Hz 28:24Hz 32:28Hz 40:38Hz 50:46Hz

Heating characteristics and outdoor temperature  
Operating conditions\*: Room 20°C, fan on HIGH

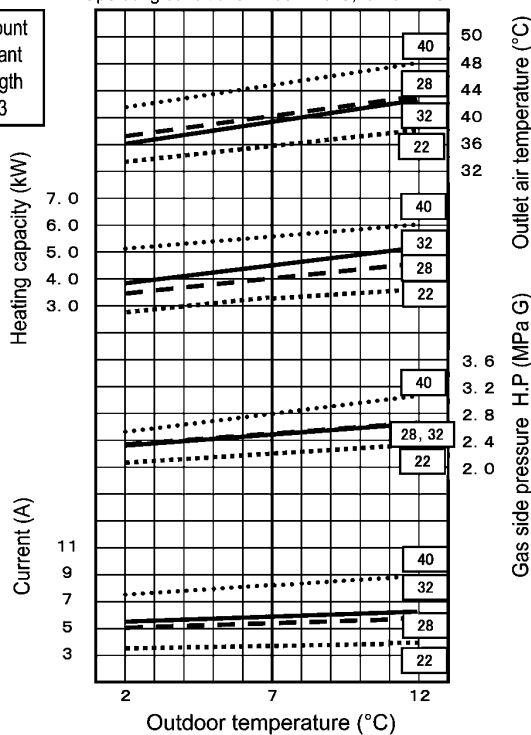

\* 22:35Hz 28:46Hz 32:52Hz 40:65Hz 50:83Hz  
\* Forced heating operation so the inside fan is set to HIGH

Rated amount of refrigerant  
Piping length  
7.5m X 3

### CU-3E23CBPG (two rooms operation)

Cooling characteristics and outdoor temperature  
Operating conditions (72Hz) : Room 27°C, fan on HIGH

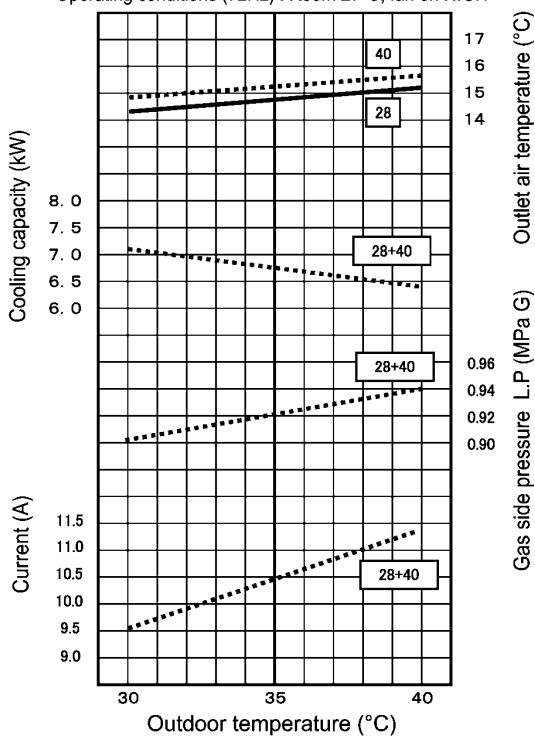

Heating characteristics and outdoor temperature  
Operating conditions (79Hz) : Room 20°C, fan on HIGH

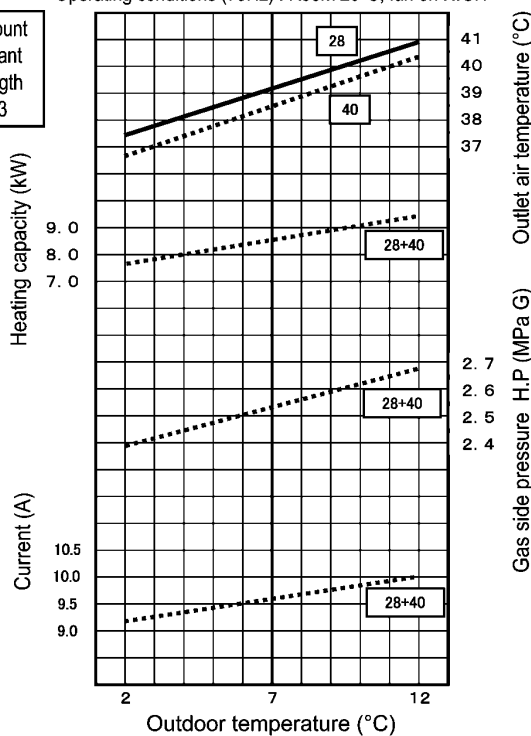

\* Forced heating operation so the inside fan is set to HIGH

Rated amount of refrigerant  
Piping length  
7.5m X 3

### CU-3E23CBPG (three rooms operation)

Cooling characteristics and outdoor temperature  
Operating conditions (62Hz): Room 27°C, fan on HIGH

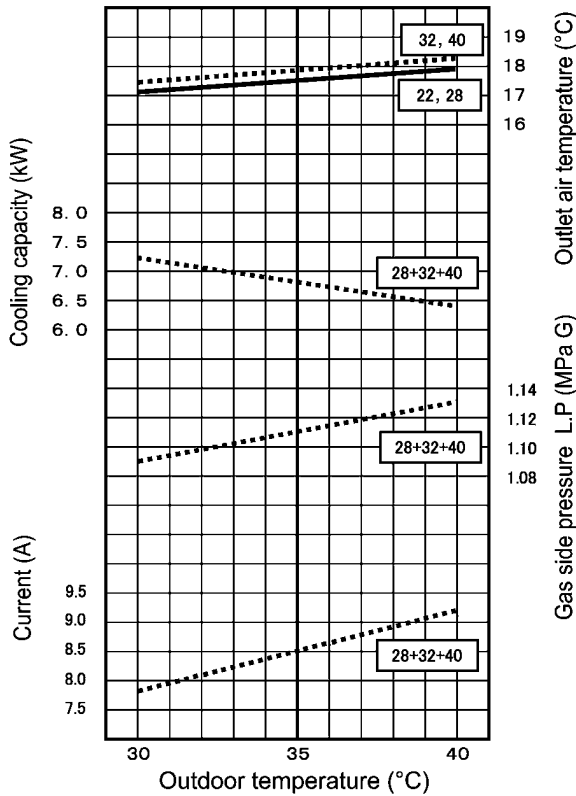

Heating characteristics and outdoor temperature  
Operating conditions (78Hz): Room 20°C, fan on HIGH

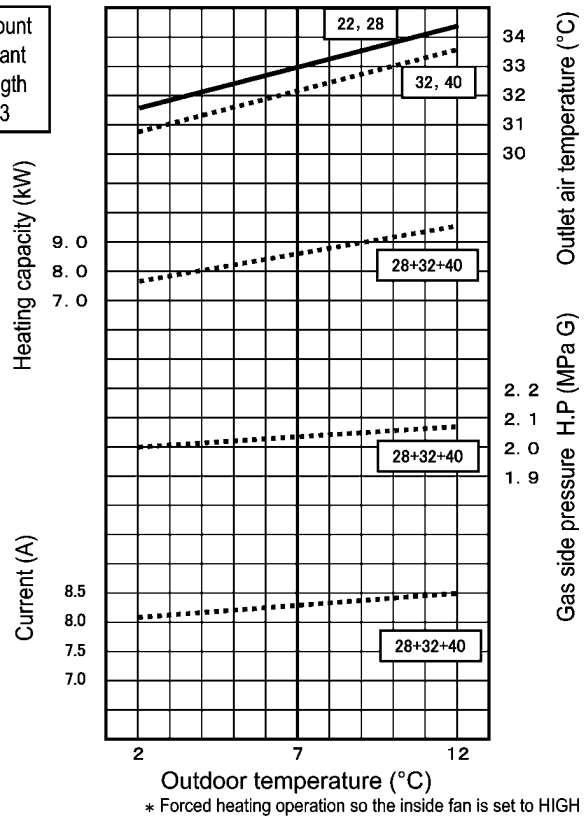

### CU-4E27CBPG (one room operation)

Cooling characteristics and outdoor temperature  
Operating conditions\*: Room 27°C, fan on HIGH

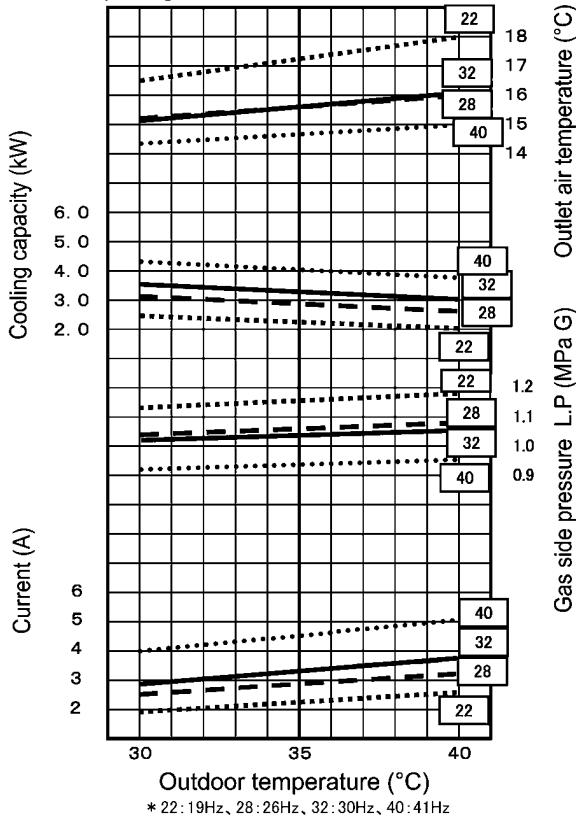

Heating characteristics and outdoor temperature  
Operating conditions\*: Room 20°C, fan on HIGH

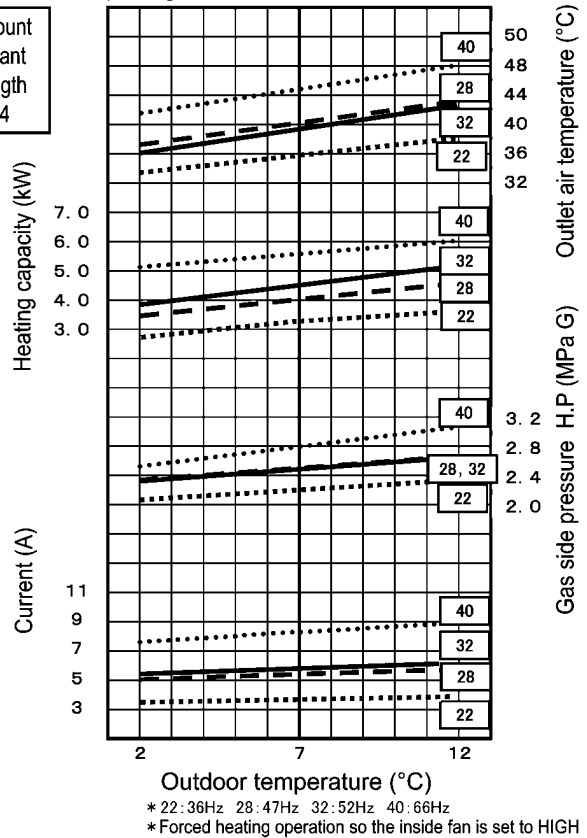

### CU-4E27CBPG (two rooms operation)

Cooling characteristics and outdoor temperature  
Operating conditions (70Hz) : Room 27°C, fan on HIGH

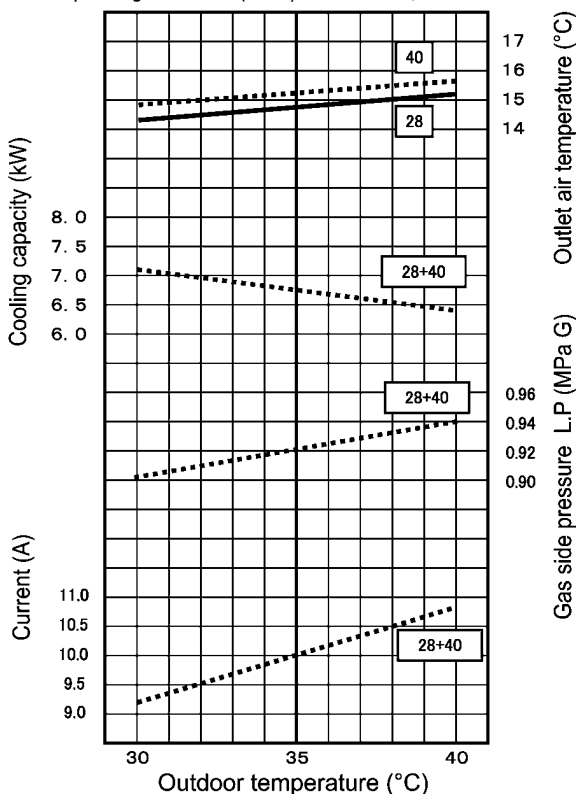

Heating characteristics and outdoor temperature  
Operating conditions (79Hz) : Room 20°C, fan on HIGH

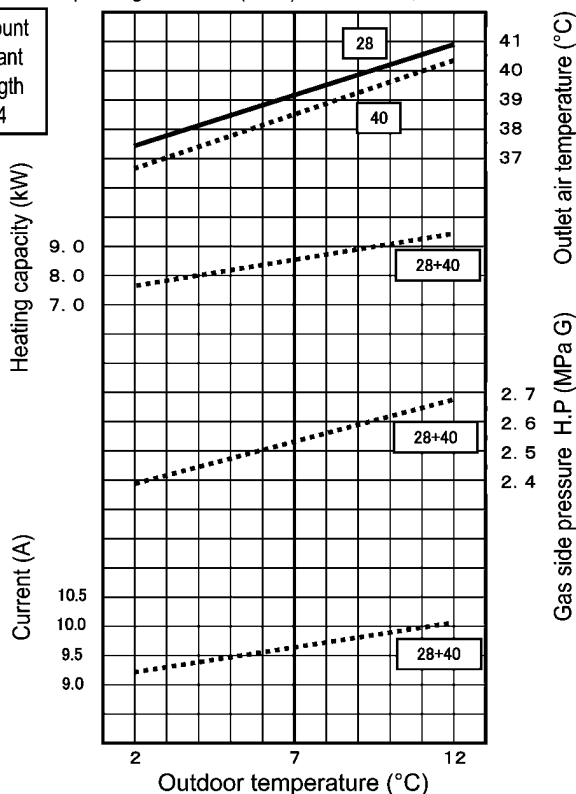

\* Forced heating operation so the inside fan is set to HIGH

### CU-4E27CBPG (three rooms operation)

Cooling characteristics and outdoor temperature  
Operating conditions (75Hz) : Room 27°C, fan on HIGH

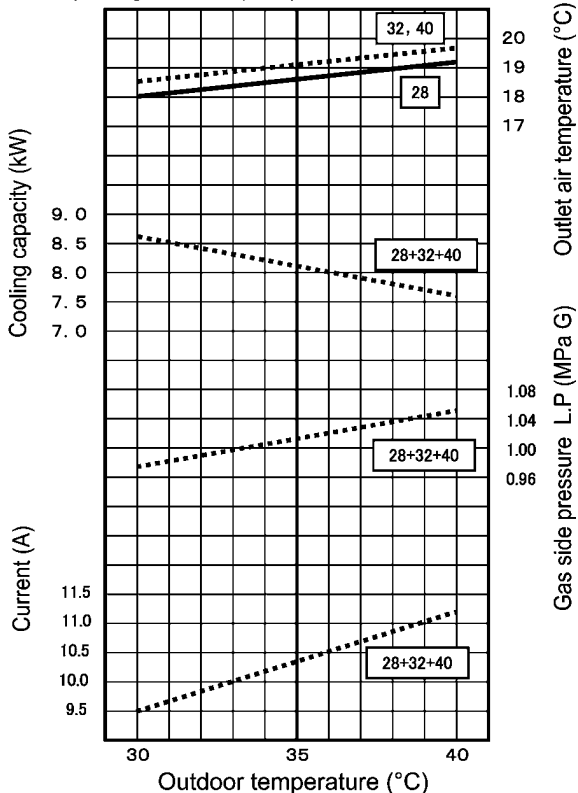

Heating characteristics and outdoor temperature  
Operating conditions (84Hz) : Room 20°C, fan on HIGH

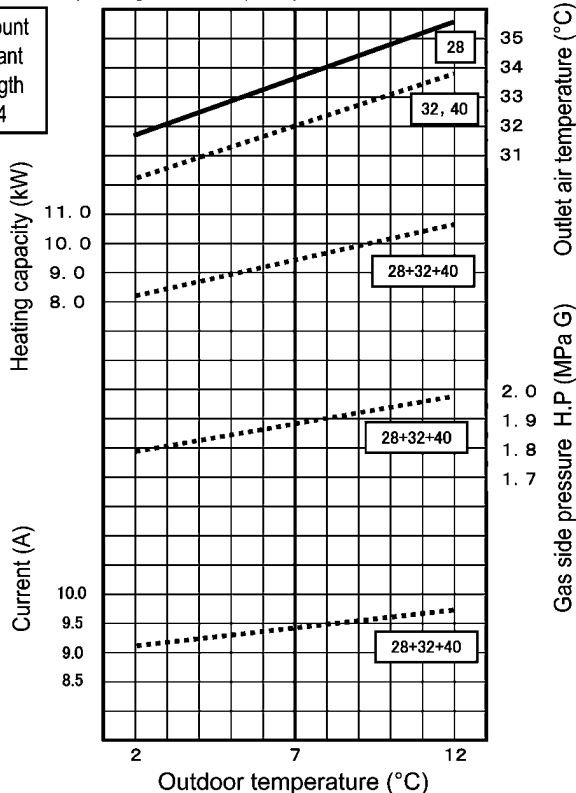

\* Forced heating operation so the inside fan is set to HIGH

**CU-4E27CBPG (four rooms operation)**

**Cooling characteristics and outdoor temperature**  
 Operating conditions (67 Hz) : Room 27°C, fan on HIGH

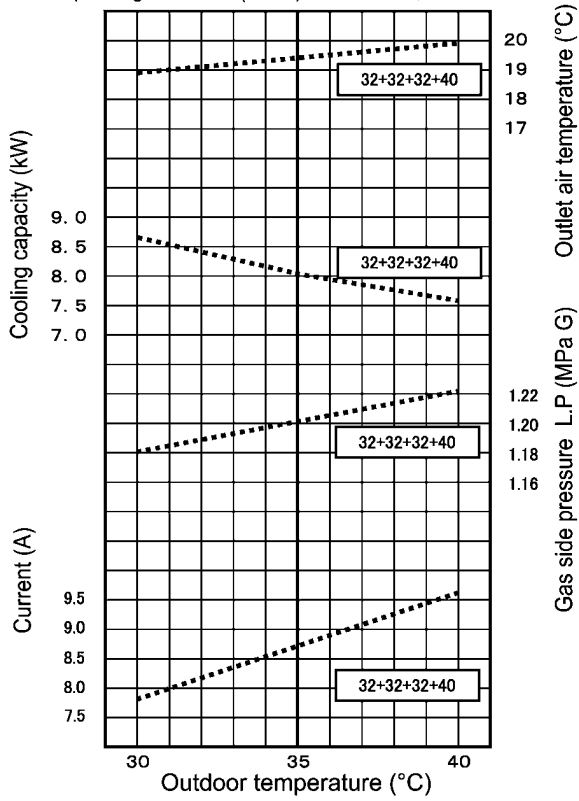

**Heating characteristics and outdoor temperature**  
 Operating conditions (84Hz): Room 20°C, fan on HIGH

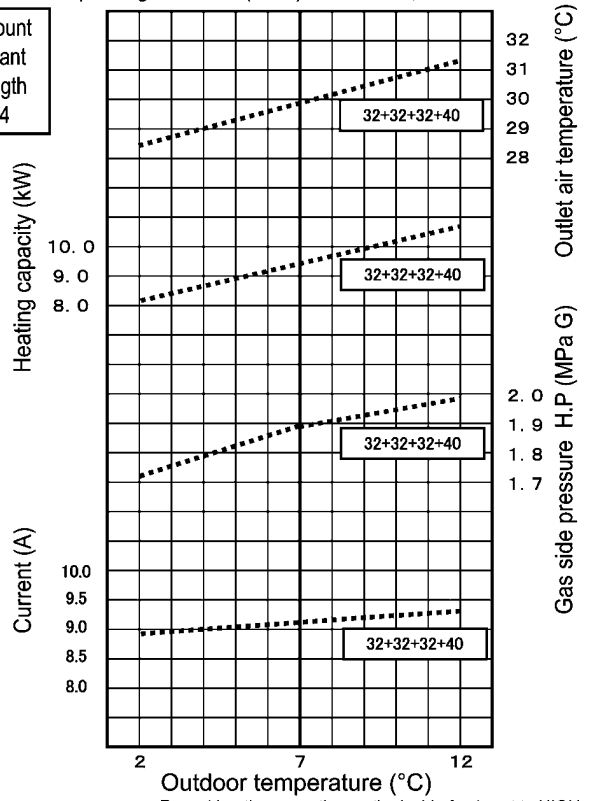

Rated amount of refrigerant  
 Piping length  
 7.5m X 4

\* Forced heating operation so the inside fan is set to HIGH

# 14 Electronic Circuit Diagram

## 14.1. REMOTE CONTROL

CS-ME7CB1P, CS-ME10CB1P, CS-ME12CB1P, CS-ME14CB1P,  
CS-ME10CD3P, CS-ME14CD3P

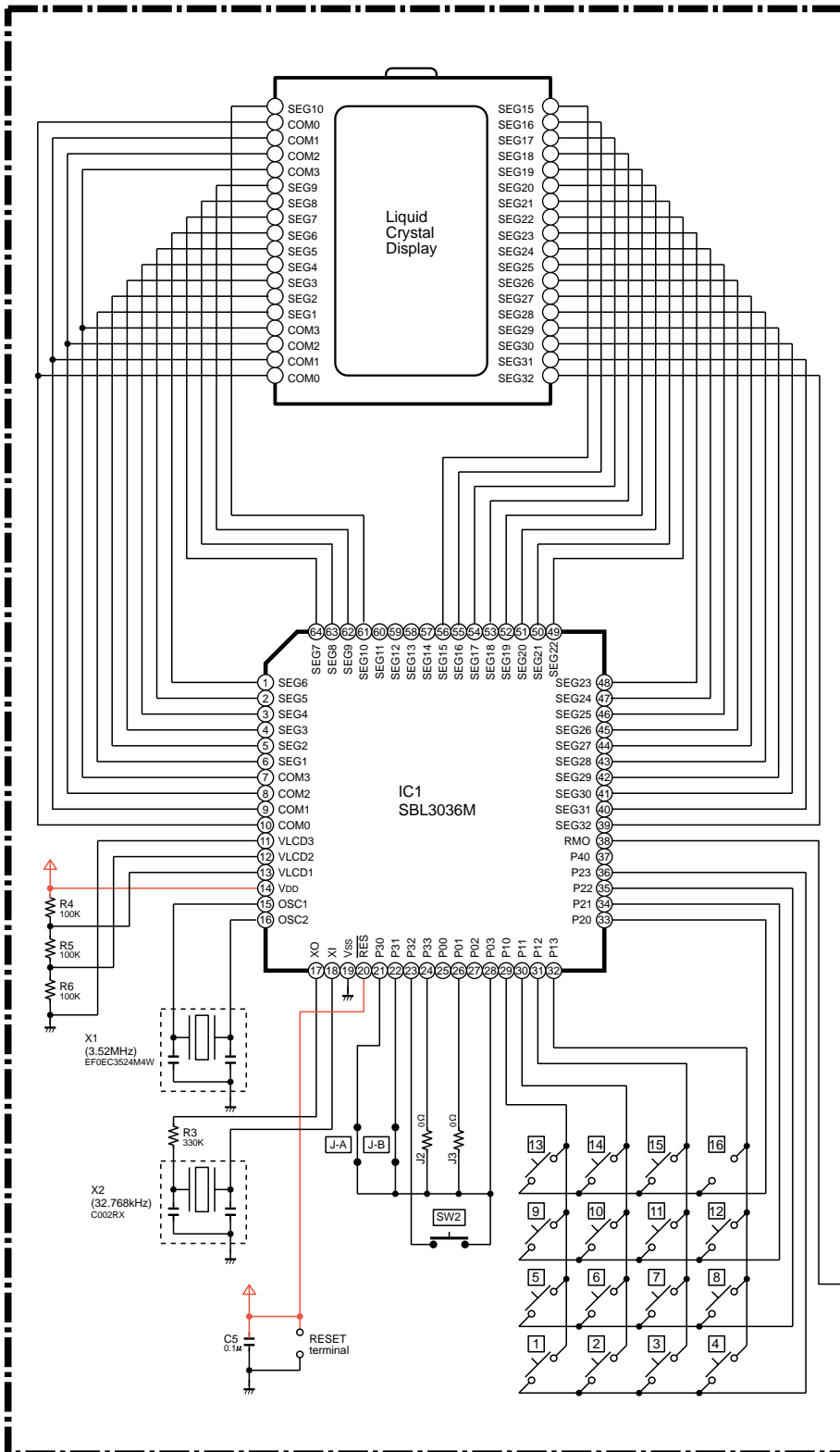

Remote Control  
Transmission Code Change

Setting	J-A	J-B	Remarks
A	ON	ON	At product delivery
B	OFF	ON	
C	ON	OFF	
D	OFF	OFF	

ON: Connected  
OFF: Disconnected

Remote Control Key

Key No.	SW2 OFF (Door is opened)	SW2 ON (Door is closed)
1	OFF / ON	OFF / ON
2	FAN SPEED	TEMP ▼
3	AIR SWING	TEMP ▲
4	ODOUR WASH	
5		
6	ON (Timer)	QUIET
7	OFF (Timer)	MODE
8	∨ (Timer)	
9	∧ (Timer)	
10	CANCEL (Timer)	POWERFUL
11	SET (Timer)	SLEEP TIMER
12		
13		
14		
15	CLOCK	
16	SET	SET

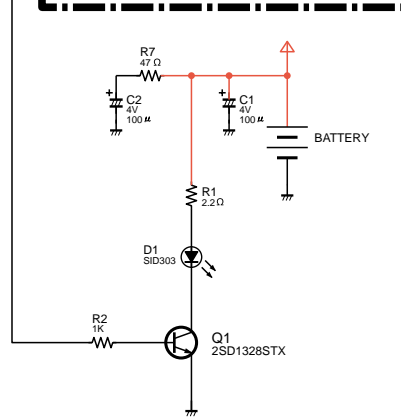

# 14.2. Cassette Type

## ELECTRONIC CIRCUIT DIAGRAM CS-ME7CB1P,CS-ME10CB1P,CS-ME12CB1P,CS-ME14CB1P

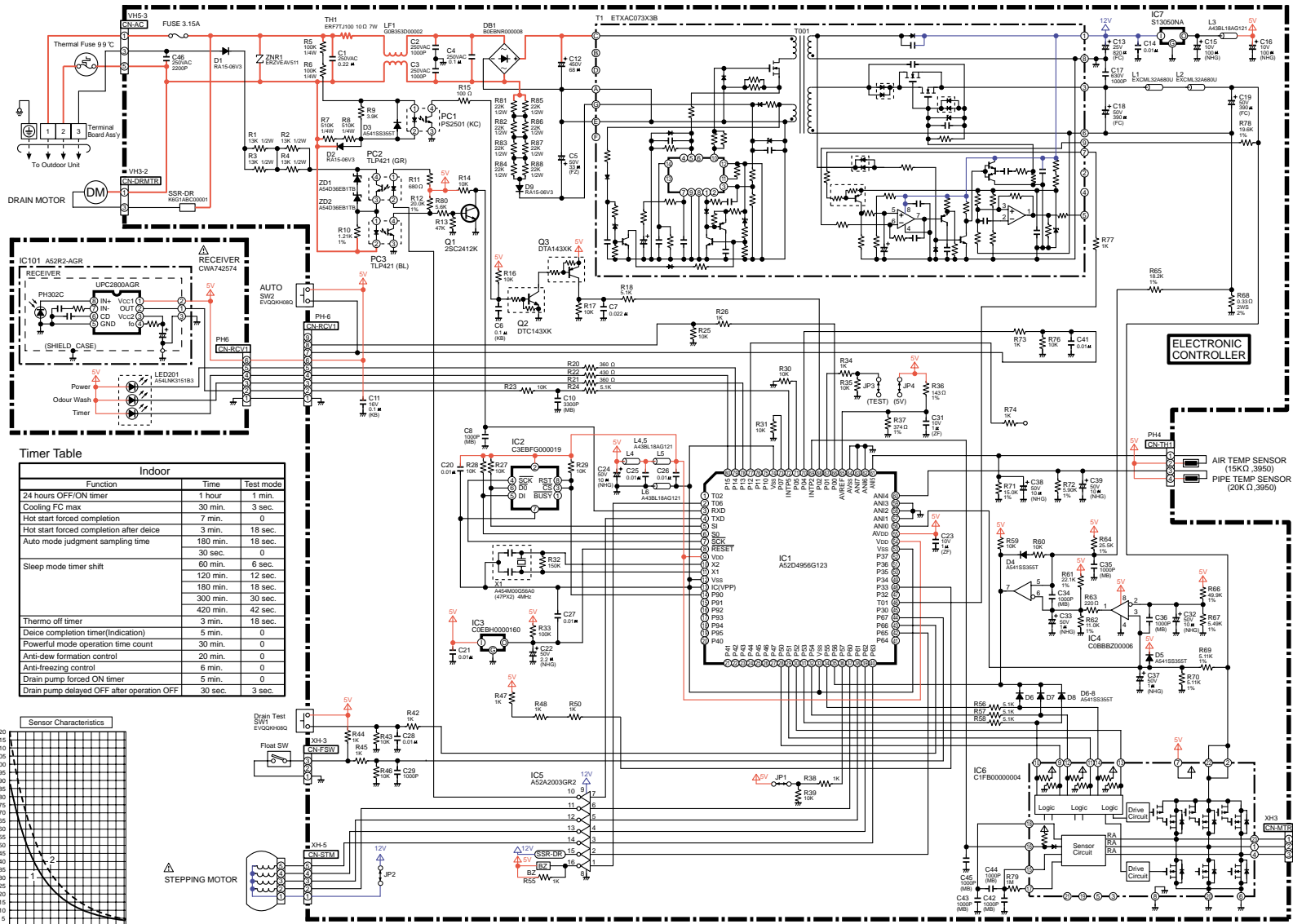

IC1 Microprocessor: AS2D4956G123

Pin No.	Pin No.	Description
1	TO2	
2	TO3	Buzzer Drive
3	TD	Data Reception
4	TD	Data Transmission
5	SI	
6	SD	
7	RESSET	Reset Signal
8	V8	+5V
9	X2	4MHz Oscillation
10	X1	4MHz Oscillation
11	V8	GND
12	IC1VPP	GND
13	P0	Data
14	P0	Data
15	P0	Data
16	P2	
17	P3	
18	P4	
19	P5	
20	P40	
21	P41	
22	P42	
23	P43	
24	P44	
25	P45	
26	P46	
27	P47	
28	P50	Fan Motor Drive
29	P51	Fan Motor Drive
30	P52	Fan Motor Drive
31	P53	Fan Motor Drive
32	P54	Fan Motor Drive
33	V8	GND
34	P55	Fan Motor Drive
35	P56	Fan Speed Detection
36	P57	
37	P60	Stepping Motor Drive
38	P61	Stepping Motor Drive
39	P62	Stepping Motor Drive
40	P63	Stepping Motor Drive
41	P64	
42	P65	SSR-DR Drive
43	P66	Drain Test
44	P67	Floot Switch
45	P68	
46	T01	Fan Speed Control
47	P32	
48	P33	
49	P34	
50	P35	
51	P36	
52	P37	GND
53	V8	GND
54	V8	+5V
55	AVDD	+5V
56	AN0	Fan Speed Control
57	AN1	
58	AN2	
59	AN3	
60	AN4	Pipe Temperature
61	XN5	Intake Air Temperature
62	AN6	
63	AN7	
64	AVSS	
65	AVREF	Power
66	P00	
67	P01	Test
68	P02	Clock Pulse
69	INTP2	Fan Speed Control
70	P04	Auto Switch
71	P05	
72	INTP5	Remote Control Signal
73	P07	
74	V8	GND
75	P10	
76	P11	
77	P12	
78	P13	Display Odour Wash
79	P14	Display Power
80	P15	Display Timer

Timer Table

Function	Time	Test mode
24 hours OFF/ON timer	1 hour	1 min.
Cooling FC max	30 min.	3 sec.
Hot start forced completion	7 min.	0
Hot start forced completion after deice	3 min.	18 sec.
Auto mode judgment sampling time	180 min.	18 sec.
	30 sec.	0
Sleep mode timer shift	60 min.	6 sec.
	120 min.	12 sec.
	180 min.	18 sec.
	300 min.	30 sec.
	420 min.	42 sec.
Thermo off timer	3 min.	18 sec.
Deice completion timer(Indication)	5 min.	0
Powerful mode operation time count	30 min.	0
Anti-dew formation control	20 min.	0
Anti-freezing control	6 min.	0
Drain pump forced ON timer	5 min.	0
Drain pump delayed OFF after operation OFF	30 sec.	3 sec.

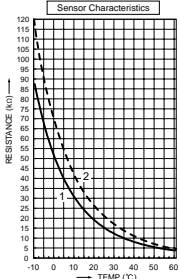

64



# 14.3. Duct Type

ELECTRONIC CIRCUIT DIAGRAM CS-ME10CD3P,CS-ME14CD3P

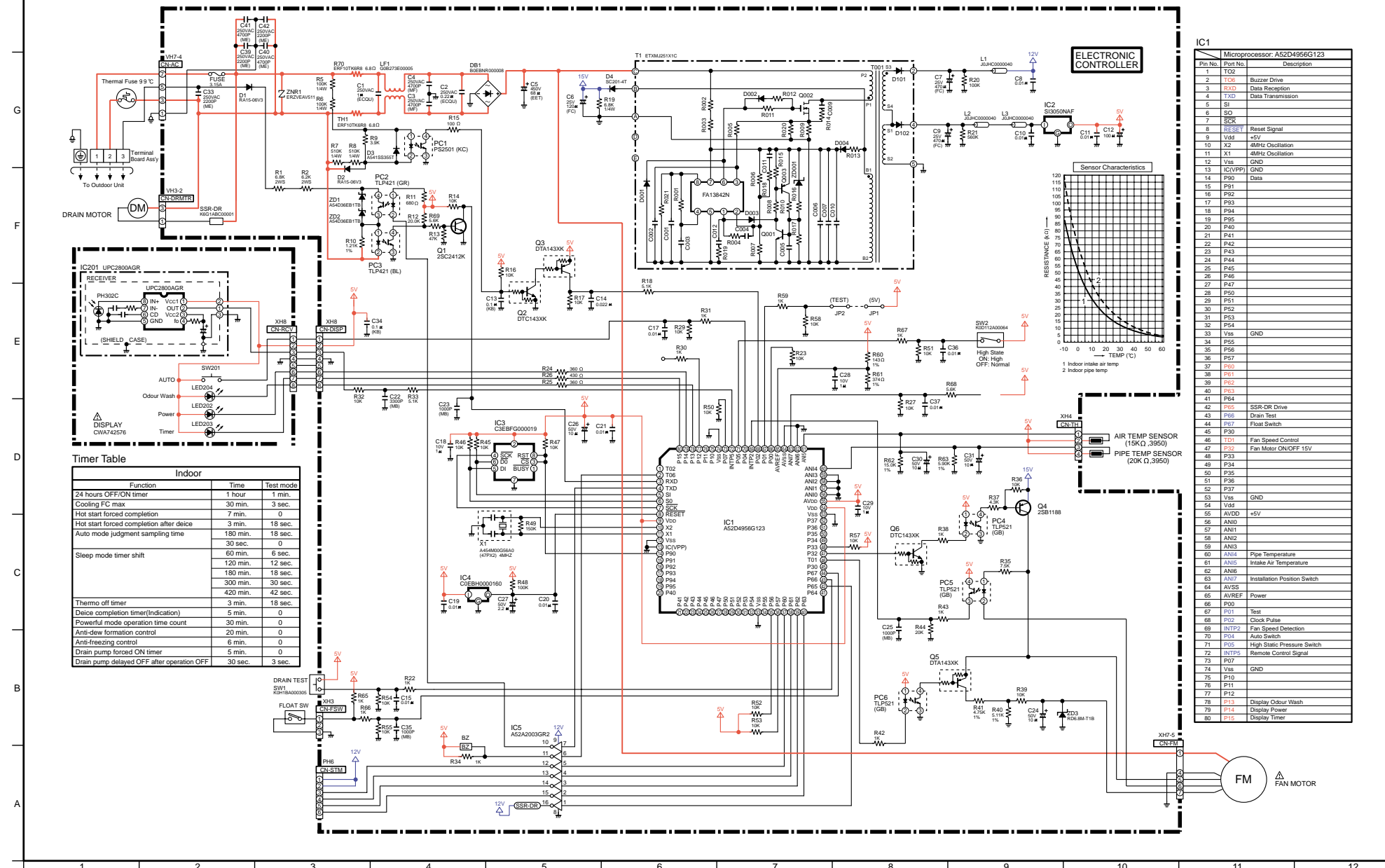

**Timer Table**

Indoor		
Function	Time	Test mode
24 hours OFF/ON timer	1 hour	1 min.
Cooling FC max	30 min.	3 sec.
Hot start forced completion	7 min.	0
Hot start forced completion after delay	3 min.	18 sec.
Auto mode judgment sampling time	180 min.	18 sec.
Sleep mode timer shift	60 min.	6 sec.
	120 min.	12 sec.
	180 min.	18 sec.
	300 min.	30 sec.
	420 min.	42 sec.
Thermo off timer	3 min.	18 sec.
Device completion timer(indication)	5 min.	0
Powerful mode operation time count	30 min.	0
Anti-dew formation control	20 min.	0
Anti-freezing control	6 min.	0
Drain pump forced ON timer	5 min.	0
Drain pump delayed OFF after operation OFF	30 sec.	3 sec.

**IC1 Microprocessor: AS2D4956G123**

Pin No.	Port No.	Description
1	TO2	
2	TO6	Buzzer Drive
3	RXD	Data Reception
4	TXD	Data Transmission
5	SI	
6	SD	
7	SPK	
8	RESET	Reset Signal
9	Vdd	+5V
10	X2	4MHz Oscillation
11	X1	4MHz Oscillation
12	Vss	GND
13	ICVPP	GND
14	P00	Data
15	P01	
16	P02	
17	P03	
18	P04	
19	P05	
20	P40	
21	P41	
22	P42	
23	P43	
24	P44	
25	P45	
26	P46	
27	P47	
28	P50	
29	P51	
30	P52	
31	P53	
32	P54	
33	Vss	GND
34	P55	
35	P56	
36	P57	
37	P50	
38	P61	
39	P62	
40	P63	
41	P64	
42	P65	SSR-DR Drive
43	P66	Drain Test
44	P67	Floot Switch
45	P30	
46	TDI	Fan Speed Control
47	TP3	Fan Motor ON/OFF 15V
48	P33	
49	P34	
50	P35	
51	P36	
52	P37	
53	Vss	GND
54	Vdd	+5V
55	AVDD	
56	AND	
57	ANI1	
58	ANI2	
59	ANI3	
60	ANI4	Pipe Temperature
61	ANI5	Intake Air Temperature
62	AN6	
63	ANI7	Installation Position Switch
64	AVSS	
65	AVREF	Power
66	P00	
67	P01	Test
68	P02	Clock Pulse
69	INTP2	Fan Speed Detection
70	P04	Auto Switch
71	P05	High State Pressure Switch
72	INTP5	Remote Control Signal
73	P07	
74	Vss	GND
75	P10	
76	P11	
77	P12	Display Odour Wash
78	P13	Display Power
79	P14	
80	P15	Display Timer

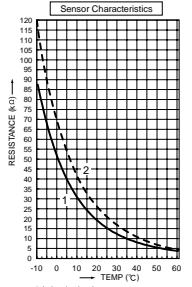

65

CS-ME10CD3P / CS-ME14CD3P / CS-ME12CD3P / CS-ME14CD3P / CS-ME10CD3P / CS-ME14CD3P

# 15 Exploded View & Replacement Parts List

## 15.1. CS-ME7CB1P/ME10CB1P/ME12CB1P/ME14CB1P

### 15.1.1. Exploded View

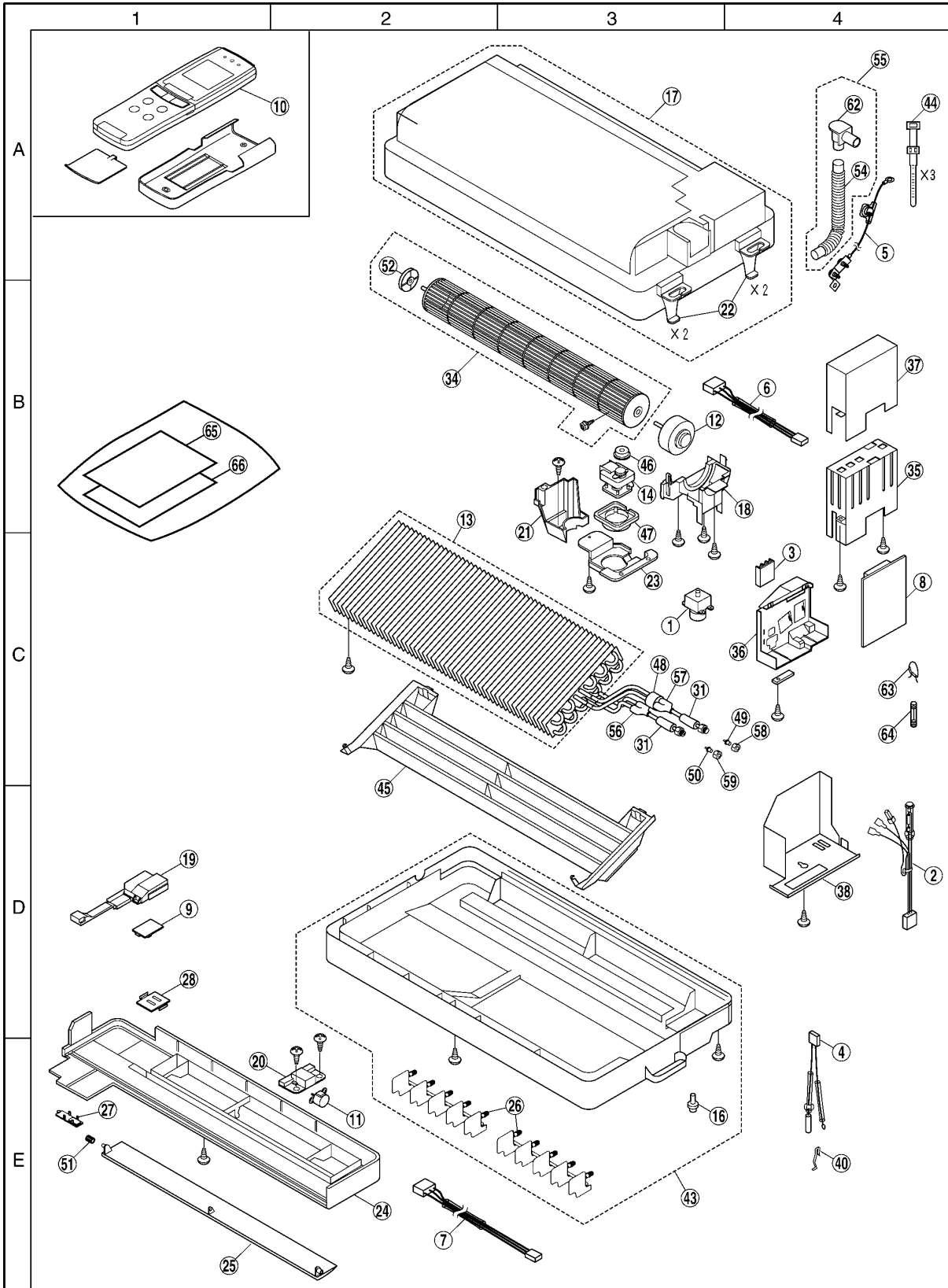

**Note:**

The above exploded view is for the purpose of parts disassembly and replacement.  
The non-numbered parts are not kept as standard service parts.

## 15.1.2. Replacement Parts List

<Model: CS-ME7CB1P / CS-ME10CB1P / CS-ME12CB1P / CS-ME14CB1P>

Ref. No.	Part Name & Description	Q'ty	Part No.				Remarks
			CS-ME7CB1P	CS-ME10CB1P	CS-ME12CB1P	CS-ME14CB1P	
1	FLOAT SWITCH	1	CWA12326	←	←	←	●
2	THERMAL FUSE	1	CWA16C1031	←	←	←	●
3	TERMINAL BOARD COMPLETE	1	CWA28K1045	←	←	←	●
4	SENSOR COMPLETE	1	CWA50C2100	←	←	←	●
5	TERMINAL PLATE FOR EARTH	1	CWA64C1005	←	←	←	
6	LEAD WIRE COMPLETE (FM)	1	CWA67C1641	←	←	←	
7	LEAD WIRE COMPLETE (AS)	1	CWA67C1643	←	←	←	
8	PC BOARD (MAIN)	1	CWA73C1458	CWA73C1459	CWA73C1460	CWA73C1461	●
9	PC BOARD (RECEIVER)	1	CWA742574	←	←	←	●
10	REMOTE CONTROL	1	CWA75C2311	←	←	←	●
11	AIR SWING MOTOR	1	CWA98168	←	←	←	●
12	FAN MOTOR	1	CWA98258	←	←	←	●
13	EVAPORATOR	1	CWB302119	←	←	CWB30C1171	
14	DRAIN PUMP	1	CWB532010	←	←	←	●
16	DRAIN CAP	1	CWB82018	←	←	←	
17	CHASSIS COMPLETE	1	CWD50C260	←	←	←	
18	FAN MOTOR BRACKET	1	CWD54232	←	←	←	
19	PARTICULAR PLATE	1	CWD66238	←	←	←	
20	PARTICULAR PIECE-1	1	CWD76223	←	←	←	
21	PARTICULAR PIECE-2	1	CWD76225	←	←	←	
22	PARTICULAR PIECE-3	4	CWD91197	←	←	←	
23	DRAIN PUMP BRACKET	1	CWD93938	←	←	←	
24	DISCHARGE GRILE COMPLETE	1	CWE20C2232	←	←	←	
25	LOUVER	1	CWE24423	←	←	←	
26	VERTICAL LOUVER	1	CWE24C101	←	←	←	
27	DECORATION PANEL	1	CWE35243	←	←	←	
28	INDICATION PLATE	1	CWE39280	←	←	←	
31	INSULATION SHEET	2	CWG10467	←	←	←	
34	CROSS-FLOW FAN COMPLETE	1	CWH02K117X	←	←	←	
35	CONTROL BOARD BOX	1	CWH10931	←	←	←	
36	CONTROL COVER-1	1	CWH131172	←	←	←	
37	CONTROL COVER-2	1	CWH13424	←	←	←	
38	CONTROL COVER-3	1	CWH13426	←	←	←	
40	HOLDER SENSOR	1	CWH32137	←	←	←	
43	DRAIN TRAY	1	CWH40C1022	←	←	←	
44	BELT	3	CWH4605004	←	←	←	
45	GUTTER	1	CWH481002X	←	←	←	
46	BUSHING FOR DRAIN PUMP-1	1	CWH50196	←	←	←	
47	BUSHING FOR DRAIN PUMP-2	1	CWH50197	←	←	←	
48	BUSHING	1	CWH50198	←	←	CWH501030	
49	CAP (1/4)	1	CWH52061	←	←	←	
50	CAP (3/8)	1	CWH52062	←	←	←	
51	CAP	1	CWH52160	←	←	←	
52	FLUCRUM	1	CWH64C017	←	←	←	
54	DRAIN PIPE	1	CWH85266	←	←	←	
55	DRAIN HOSE COMPLETE	1	CWH85C038	←	←	←	
56	TUBE ASSY (3/8)	1	CWT022528	←	←	CWT022529	
57	TUBE ASSY (1/4)	1	CWT022530	←	←	CWT022531	
58	FLARE NUT (1/4)	1	CWT25086	←	←	←	
59	FLARE NUT (3/8)	1	CWT25087	←	←	←	
62	JOINT FOR DRAIN PIPE	1	CWT29116	←	←	←	
63	ZNR	1	ERZVEAV511	←	←	←	
64	FUSE (250V 3A)	1	K5D312BB0002	←	←	←	
65	OPERATING INSTRUCTIONS	1	CWF563997	←	←	←	
66	INSTALLATION INSTRUCTIONS	1	CWF612424	←	←	←	

(Note)

- "●" marked parts are recommended to be kept in stock.
- All parts are supplied from ACD, JAPAN (VENDER CODE : 00025800).

## 15.2. CS-ME10CD3P/ME14CD3P

### 15.2.1. Exploded View

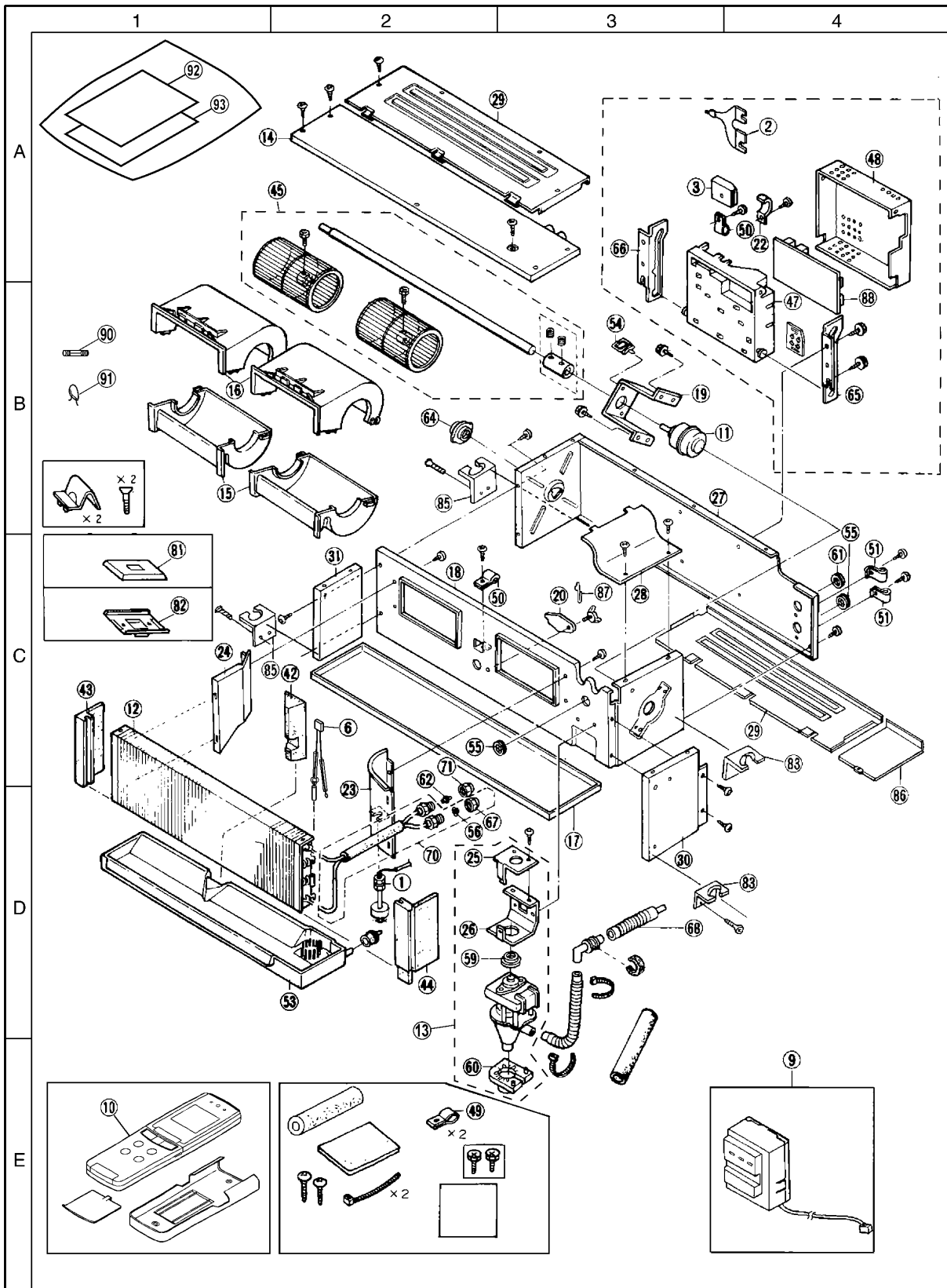

Note:

The above exploded view is for the purpose of parts disassembly and replacement.

The non-numbered parts are not kept as standard service parts.

## 15.2.2. Replacement Parts List

<Model: CS-ME10CD3P / CS-ME14CD3P>

Ref. No.	Part Name & Description	Q'ty	Part No.		Remarks
			CS-ME10CD3P	CS-ME14CD3P	
1	FLOAT SWITCH	1	CWA12161	←	●
2	THERMAL FUSE	1	CWA16C1030	←	●
3	TERMINAL BOARD COMPLETE	1	CWA28K188	←	●
6	SENSOR COMPLETE	1	CWA50C2116	←	●
9	REMOTE CONTROL (RECEIVER)	1	CWA75C2337	←	●
10	REMOTE CONTROL	1	CWA75C2311	←	●
11	FAN MOTOR	1	CWA981071	←	●
12	EVAPORATOR	1	CWB302123	←	
13	DRAIN PUMP	1	CWB53C1010	←	●
14	PARTICULAR PLATE-1	1	CWD11024X	←	
15	AIR GUIDER-1	2	CWD32091	←	
16	AIR GUIDER-2	2	CWD32092	←	
17	BOTTOM PLATE	1	CWD52259	←	
18	BULKHEAD	1	CWD53063	←	
19	BRACKET FAN MOTOR	1	CWD541036	←	
20	PARTICULAR PLATE-2	1	CWD74100	←	
22	HOLDER LEAD WIRE-1	1	CWD77003	←	
23	PARTICULAR PLATE-3	1	CWD90K080	←	
24	PARTICULAR PLATE-4	1	CWD90616	←	
25	PARTICULAR PLATE-5	1	CWD90618	←	
26	PARTICULAR PLATE-6	1	CWD90766	←	
27	CABINET BACK PLATE	1	CWE02079	←	
28	CABINET TOP PLATE-1	1	CWE03034	←	
29	CABINET TOP PLATE-2	2	CWE03035	←	
30	CABINET SIDE PLATE-1	1	CWE04071	←	
31	CABINET SIDE PLATE-2	1	CWE04072	←	
42	INSULATION SHEET-1	1	CWG07165	←	
43	INSULATION SHEET-2	1	CWG07166	←	
44	INSULATION SHEET-3	1	CWG07167	←	
45	CROSS-FLOW FAN COMPLETE	1	CWH01C005	←	
47	CONTROL BOARD BOX	1	CWH10527	←	
48	CONTROL COVER	1	CWH131144	←	
49	HOLDER LEAD WIRE-2	2	CWH31062	←	
50	HOLDER LEAD WIRE-3	2	CWH31030	←	
51	HOLDER LEAD WIRE-4	2	CWH31044	←	
53	DRAIN TRAY	1	CWH40C061	←	
54	BELT	1	CWH4605008	←	
55	BUSHING-1	2	CWH4610440	←	
56	CAP-1	1	CWH52061	←	
59	BUSHING-2	1	CWH50147	←	
60	BUSHING-3	1	CWH50146	←	
61	BUSHING-4	1	CWH51134	←	
62	CAP-2	1	CWH52062	←	
64	FULCRUM	1	CWH64C015	←	
65	GUIDER-1	1	CWH69024	←	
66	GUIDER-2	1	CWH69025	←	
67	FLARE NUT (1/4)	1	CWT25086	←	
68	DRAIN HOSE	1	CWH85C008	←	
70	TUBE ASSY	1	CWT01C2422	←	
71	FLARE NUT (3/8)	1	CWT25087	←	
81	COVER FOR RECEIVER	1	CWD66132B	←	
82	RECEIVER PIECE-1	1	CWD90650	←	
83	PARTICULAR PIECE-1	2	CWD93435	←	
85	PARTICULAR PIECE-2	2	CWD93436	←	
86	CABINET BOTTOM PLATE	1	CWE05012	←	
87	HOLDER SENSOR-2	1	CWH32137	←	
88	PC BOARD (MAIN)	1	CWA73C1462	CWA73C1463	●
90	FUSE (250V 3A)	1	K5D312BB0002	←	
91	ZNR	1	ERZVEAV511	←	
92	OPERATING INSTRUCTIONS	1	CWF563997	←	
93	INSTALLATION INSTRUCTIONS	1	CWF612425	←	

(Note)

- "●" marked parts are recommended to be kept in stock.
- All parts are supplied from ACD, JAPAN (VENDER CODE : 00025800).