

# Service Manual

## Air Conditioner

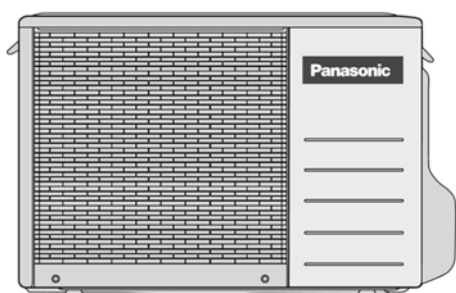

**CS-A7DKD CU-A7DKD**  
**CS-A9DKD CU-A9DKD**  
**CS-A12DKD CU-A12DKD**

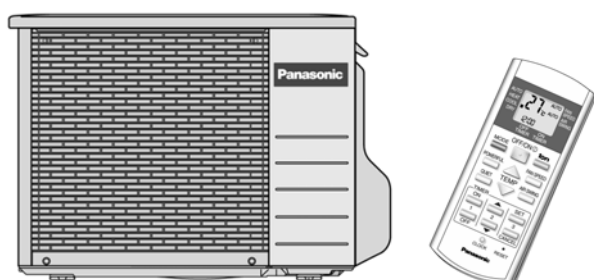

### ⚠ WARNING

This service information is designed for experienced repair technicians only and is not designed for use by the general public. It does not contain warnings or cautions to advise non-technical individuals of potential dangers in attempting to service a product. Products powered by electricity should be serviced or repaired only by experienced professional technicians. Any attempt to service or repair the product or products dealt with in this service information by anyone else could result in serious injury or death.

## CONTENTS

	Page		Page
<b>1 Features</b> .....	2	4.1. Indoor Unit & Remote Control .....	12
<b>2 Functions</b> .....	3	4.2. Outdoor Unit .....	13
2.1. Remote Control .....	3	<b>5 Refrigeration Cycle Diagram</b> .....	14
2.2. Indoor Unit .....	4	<b>6 Block Diagram</b> .....	15
2.3. Outdoor Unit .....	5	<b>7 Wiring Diagram</b> .....	17
<b>3 Product Specifications</b> .....	6	<b>8 Operation Details</b> .....	19
3.1. CS-A7DKD CU-A7DKD .....	6	8.1. Heating Operation .....	19
3.2. CS-A9DKD CU-A9DKD .....	8	8.2. Cooling Operation .....	20
3.3. CS-A12DKD CU-A12DKD .....	10	8.3. Soft Dry Operation .....	21
<b>4 Dimensions</b> .....	12		

# Panasonic®

© 2005 Panasonic HA Air-Conditioning (M) Sdn Bhd (11969-T). All rights reserved. Unauthorized copying and distribution is a violation of law.

8.4. Automatic Operation .....	22	12.3. Indoor Fan Motor And Cross Flow Fan Removal Procedures .....	64
8.5. Operation Control .....	23	12.4. Auto OFF/ON Button .....	65
8.6. Indoor Fan Speed Control .....	30	12.5. Remote Control Reset .....	66
8.7. Outdoor Fan Speed Control .....	32	<b>13 Troubleshooting Guide .....</b>	<b>67</b>
8.8. Vertical Airflow Direction Control .....	32	13.1. Refrigeration Cycle System .....	67
8.9. Horizontal Airflow Direction Control .....	33	13.2. Relationship Between The Condition Of The Air Conditioner And Pressure And Electric Current .....	68
8.10. Powerful Operation .....	33	13.3. Diagnosis Methods Of A Malfunction Of A Compressor And 4-way Valve .....	68
8.11. Quiet Operation .....	35	<b>14 Technical Data .....</b>	<b>69</b>
8.12. Ionizer Operation .....	37	14.1. Thermostat Characteristics .....	69
8.13. Timer Control .....	38	14.2. Operation Characteristics .....	70
8.14. Random Auto Restart Control .....	38	<b>15 Exploded View (Indoor Unit) .....</b>	<b>73</b>
8.15. Remote Control Signal Receiving Sound .....	38	15.1. CS-A7DKD CS-A9DKD CS-A12DKD .....	73
<b>9 Operating Instructions .....</b>	<b>39</b>	<b>16 Replacement Parts List (Indoor Unit) .....</b>	<b>74</b>
<b>10 Installation Instructions .....</b>	<b>45</b>	<b>17 Exploded View (Outdoor Unit) .....</b>	<b>75</b>
10.1. Safety Precautions .....	45	17.1. CU-A7DKD CU-A9DKD .....	75
10.2. Attached accessories .....	47	17.2. CU-A12DKD .....	76
10.3. Select the best location .....	47	<b>18 Replacement Parts List (Outdoor Unit) .....</b>	<b>77</b>
10.4. Indoor/Outdoor Unit Installation Diagram .....	47	<b>19 Electronic Circuit Diagram .....</b>	<b>79</b>
10.5. Indoor unit .....	48	19.1. Indoor Unit & Outdoor Unit .....	79
10.6. Outdoor unit .....	51	19.2. Remote Control .....	85
<b>11 2-way, 3-way Valve .....</b>	<b>56</b>	19.3. Print Pattern Indoor Unit Printed Circuit Board .....	86
11.1. Air Purging of the Piping and Indoor Unit .....	57	19.4. Print Pattern Indicator & Receiver Printed Circuit Board .....	88
<b>12 Servicing Information .....</b>	<b>63</b>		
12.1. Distinction Of Lead Free (PbF) Printed Circuit Board .....	63		
12.2. Indoor Electronic Controllers Removal Procedures .....	63		

# 1 Features

- **High Efficiency**
- **Compact Design**
- **Wider range of horizontal discharge air.**
- **Air Filter with function to reduce dust and smoke.**
- **Automatic air swing and manual adjusted by Remote Control for vertical airflow.**
- **Long installation piping.**
  - CS/CU-A7DK, CS/CU-A9DK, long piping up to 10 meter.
  - CS/CU-A12DK, long piping up to 15 meter.
- **Supersonic Air Purifying Device with SUPER allerbuster.**
  - Inactive various harmful airborne elements including allergen, viruses and bacteria.
  - Generated supersonic waves enhance the ability to collect dust and dirt in the air.
- **Quality Improvement**
  - Random auto restart after power failure for safety restart operation.
  - Gas leakage protection.
  - Prevent Compressor reverse cycle.
  - Inner protector to protect Compressor.
  - Noise prevention during soft dry operation.
  - Blue Coated Condenser for high resistance to corrosion.
- **Operation Improvement**
  - Quiet mode to provide quiet operation.
  - Powerful mode to reach the desired room temperature quickly.
  - Ionizer control for generating negative ion in discharge air.
  - 24-hour timer setting.
- **Serviceability Improvement**
  - Removable and washable Front Panel.

## 2 Functions

### 2.1. Remote Control

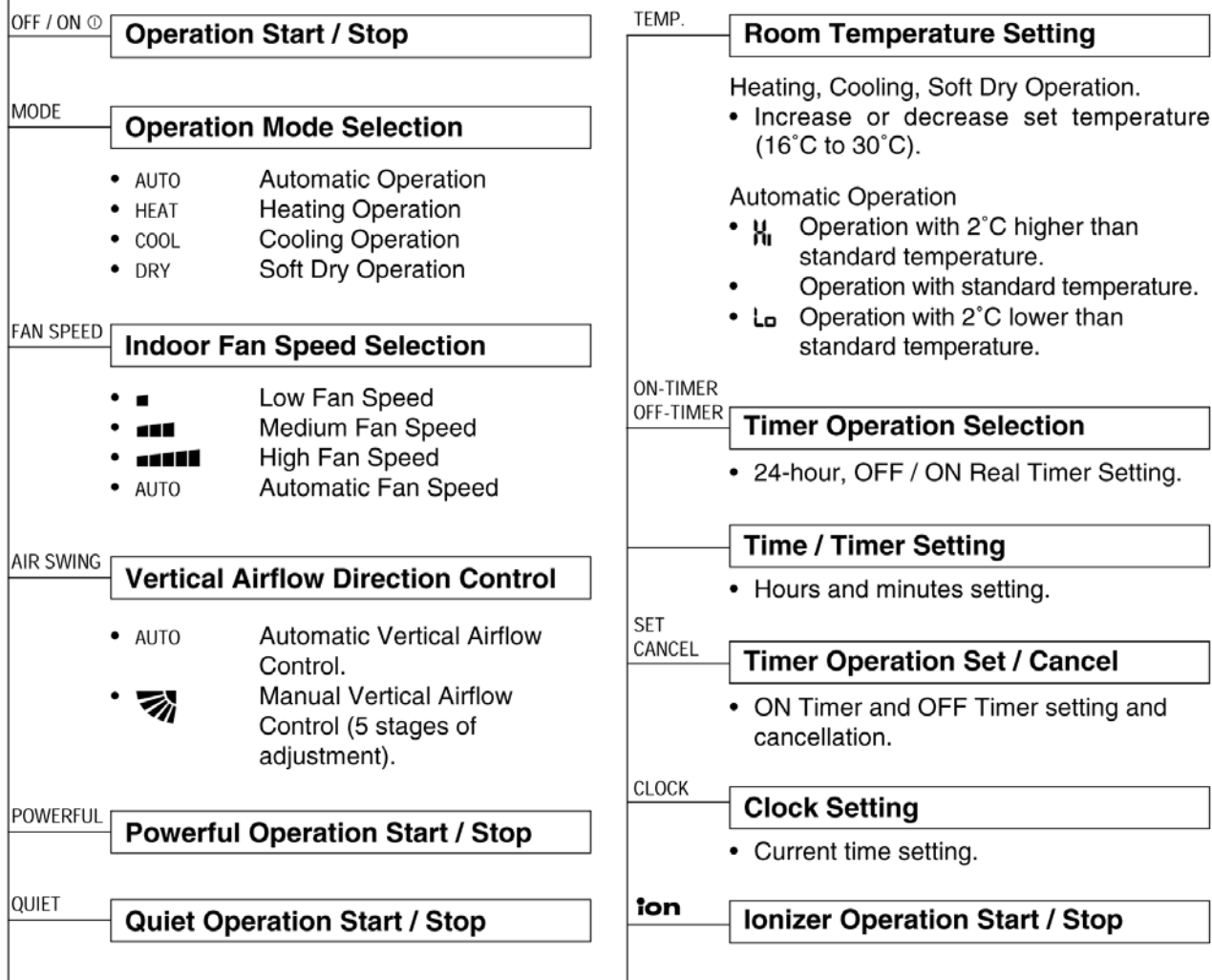
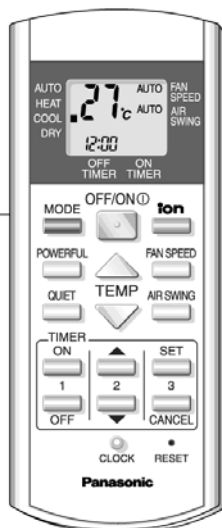

## 2.2. Indoor Unit

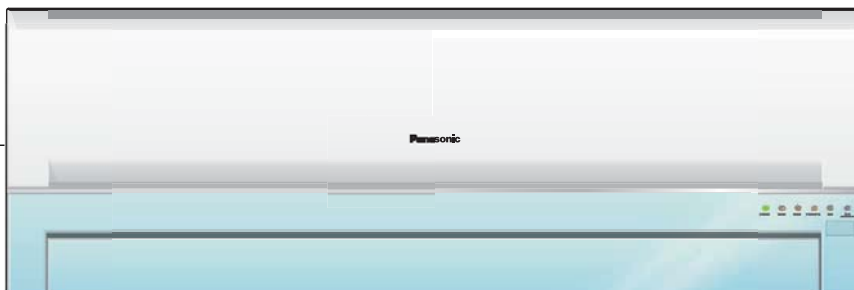

AUTO  
OFF / ON

### Automatic Operation Button

- Press for < 5 second to operate Automatic operation mode. Used when the remote control cannot be used.
- Press for ≥ 5 second to operate Cooling operation mode and compressor force to on ("beep" sound will heard). Used when test running or servicing.
- Within 20 second of Cooling operation, press continuously for 5 second to enter various setting mode. "beep, beep" sound will be heard. (Used to toggle remote control signal receiving sound or select remote control transmission code).

### Operation Indication Lamps (LED)

- POWER (Green) ..... Lights up in operation, blinks in Automatic Operation judging and Hot Start operation.
- TIMER (Orange) ..... Lights up in Timer Setting.
- QUIET (Orange) ..... Lights up in Quiet Operation.
- POWERFUL (Orange) ..... Lights up in Powerful Operation.
- ION (Green) ..... Lights up in Ionizer Operation.
- SUPER ALLERU-BUSTER (Blue) ... Lights up in operation.

### Operation Mode

- Heating, Cooling, Soft Dry and Automatic Operation.

### Powerful Operation

- Reaches the desired room temperature quickly.

### Timer Operation

- Delay OFF/ON Timer control.

### Quiet Operation

- To provide quiet operation.

### Ionizer Operation

- Generate and discharge negative ion.

### Random Auto Restart Control

- Unit will be restarted, when resume from power failure, at previous setting.

### Indoor Fan Speed Control

- Manual control fan speed (High, Medium and Low).
- Automatic fan speed.

### Airflow Direction Control

- Vertical airflow control can be adjusted automatically or manually by remote control.
- Horizontal airflow can be manually adjusted by hand.

### Anti-Freezing Control

- To prevent indoor heat exchanger from freezing.

### Starting Current Control

- To reduce the starting current.

### Time Delay Safety Control

- Restarting is inhibited for approx. 3 minutes.

### 7 Minutes Time Save Control

- To reduce the built up humidity inside the room.

### Anti-Dew Formation Control

- Anti-Dew Formation Control for indoor unit discharge area.

### 30 Minutes Time Save Control

- Heating operation only.

### Hot-Start Control

- To prevent cold air being discharge during Heating operation starts.

### Anti Cold Draft Control

- To prevent the cold draft during Heating mode operation in thermo off condition.

## 2.3. Outdoor Unit

CU-A7DKD / CU-A9DKD

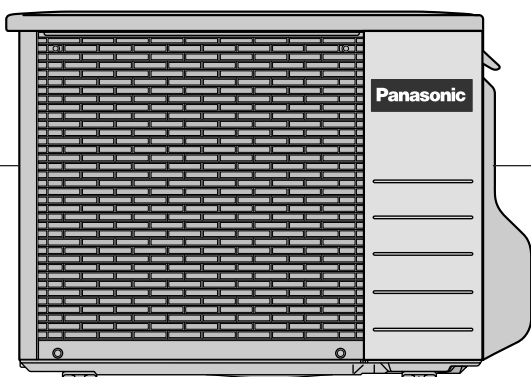

CU-A12DKD

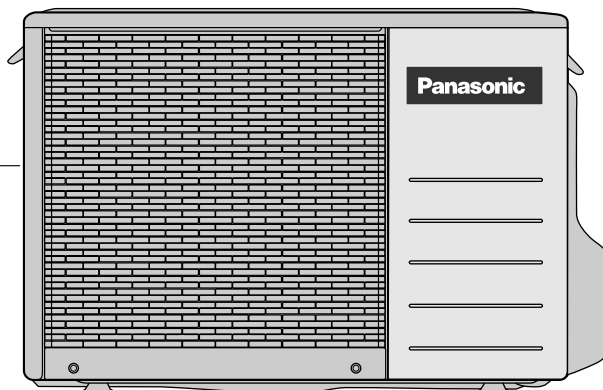

### Compressor Reverse Rotation Protection Control

- To protect compressor from reverse rotation when there is a instantaneous power failure.

### Overload Protector

- OLP to protect the compressor. Overload Protector will trip when
  - Temperature of compressor increases to 120°C.
  - High temperature or high current flows to compressor. (Refer circuit diagram for OLP characteristic)

### 60 Secs. Forced Operation Control

- Once the compressor is activated, it does not stop within the first 60 secs. However, it stops immediately with remote control stop signal.

### Outdoor Fan Operation Control

- Temperature Fuse.

### Deice Control

- To prevent frosting at outdoor heat exchanger. (Only for Heating Operation)
- Temperature of outdoor heat exchanger is sensed by TRS (Thermal Reed Switch). TRS OFF temperature 4°C. TRS ON temperature -3°C.

### Overload Protection Control

- Outdoor fan stops when indoor heat exchanger temperature rises to 51°C and above, and restarts when the indoor heat exchanger temperature drops to 49°C and below.
- Compressor stop when indoor heat exchanger temperature reaches 65°C or above. (Heating Operation Only)

### Compressor Protection Control



- If the outdoor fan motor is not running after compressor starts for 50 secs., compressor will stop. (Cooling and Soft Dry Operation only).

### 4-Way Valve Control

- When the unit is switched to "OFF" during Heating Operation, 4-way valve stays at Heating position for 5 minutes.

### 3 Product Specifications

#### 3.1. CS-A7DKD CU-A7DKD

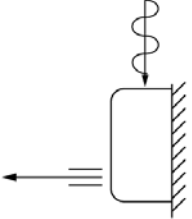
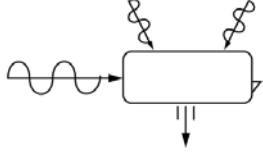
		Unit	Indoor Unit	Outdoor Unit
Power Source (Phase, Voltage, Cycle)		ø, V, Hz	Single, 220 - 230, 50	
Cooling Capacity		kW (BTU/h)	2.00 - 2.00 (6,820 - 6,820)	
Heating Capacity		kW (BTU/h)	2.10 - 2.10 (7,160 - 7,160)	
Moisture Removal		l/h (Pint/h)	1.3 (2.7)	
Airflow Method		<p>OUTLET</p>  <p>INTAKE</p> 	<p>SIDE VIEW</p> 	<p>TOP VIEW</p> 
Air Volume	Lo	m <sup>3</sup> /min (cfm)	Cooling; 5.8 (205) - 5.8 (205) Heating; 6.2 (219) - 6.2 (219)	—
	Me	m <sup>3</sup> /min (cfm)	Cooling; 6.8 (241) - 6.8 (241) Heating; 6.8 (241) - 6.8 (241)	—
	Hi	m <sup>3</sup> /min (cfm)	Cooling; 7.8 (280) - 7.8 (280) Heating; 9.0 (320) - 9.0 (320)	Cooling; 29.5 (1,040) - 30.0 (1,060)
	SHi	m <sup>3</sup> /min (cfm)	Cooling; 9.1 (320) - 9.1 (320) Heating; —	—
Noise Level		dB (A)	Cooling; High 33 - 33, Low 26 - 26 Heating; High 36 - 36, Low 28 - 28	Cooling; High 46 - 47 Heating; High 48 - 49
		Power level dB	Cooling; High 46 - 46 Heating; High 49 - 49	Cooling; High 61 - 62 Heating; High 64 - 65
Electrical Data	Input Power	kW	Cooling; 0.61 - 0.63 Heating; 0.50 - 0.525	
	Running Current	A	Cooling; 2.9 - 2.8 Heating; 2.4 - 2.4	
	EER	W/W (BTU/hW)	Cooling; 3.28 - 3.17 (11.2 - 10.8)	
	COP	- (BTU/hW)	Heating; 4.2 - 4.0 (14.3 - 13.6)	
	Starting Current	A	12.4	
Piping Connection Port (Flare piping)		inch inch	G ; Half Union 3/8" L ; Half Union 1/4"	G ; 3-way valve 3/8" L ; 2-way valve 1/4"
Pipe Size (Flare piping)		inch inch	G ; (gas side) 3/8" L ; (liquid side) 1/4"	G ; (gas side) 3/8" L ; (liquid side) 1/4"
Drain Hose	Inner diameter	mm	12	
	Length	mm	650	
Power Cord	Length	m	1.9	
	Number of core-wire		3 (1.5 mm <sup>2</sup> )	
Dimensions	Height	inch (mm)	11 - 1/32 (280)	
	Width	inch (mm)	31 - 15/32 (799)	
	Depth	inch (mm)	7 - 7/32 (183)	
Net Weight		lb (kg)	20 (9.0)      53 (24)	
Compressor	Description		—	
	Motor Type		—	
	Rated Output	W	—	
			550	

		Unit	Indoor Unit	Outdoor Unit	
Fan Motor	Description		Cross-flow Fan	Propeller Fan	
	Material		AS + Glass Fiber 20%	PP Resin	
	Type		Induction (4-poles)	Induction (6-poles)	
	Input	W	60.5 - 66.0	66 - 74.8	
	Rated	Output	W	15	30
	Fan Speed	Low	rpm	Cooling; 780 - 780 Heating; 840 - 840	—
		Medium	rpm	Cooling; 920 - 920 Heating; 920 - 920	—
		High	rpm	Cooling; 1,050 - 1,050 Heating; 1,220 - 1,220	800 - 830
SuperHigh		rpm	Cooling; 1,220 - 1,220 Heating; —	—	
Heat Exchanger	Description		Evaporator	Condenser	
	Tube material		Copper	Copper	
	Fin material		Aluminium (Pre Coat)	Aluminium (Blue Coat)	
	Fin Type		Slit Fin	Corrugated Fin	
	Row / Stage		(Plate fin configuration, forced draft)		
			2 × 15	2 × 23	
	FPI		21	17	
	Size (W × H × L)	mm	610 × 315 × 25.4	585.7 × 484 × 36.4 557.1	
Refrigerant Control Device			—	Capillary Tube	
Refrigeration Oil		(cm <sup>3</sup> )	—	ATMOS M60 OR SUNISO 4GDID	
Refrigerant (R22)		g (oz)	—	690 (24.3)	
Thermostat			—	—	
Protection Device			—	Overload Protector	
Capillary Tube	Length	mm	—	Cooling; 330, Heating; 566	
	Flow Rate	l/min	—	Cooling; 20.6, Heating; 9.5	
	Inner Diameter	mm	—	Cooling; 1.7, Heating; 1.4	
Air Filter	Material		P.P.	—	
	Style		Honeycomb	—	
Capacity Control			Capillary Tube		
Compressor Capacitor		μF, VAC	—	20 μF, 370VAC	
Fan Motor Capacitor		μF, VAC	1.5 μF, 440VAC	2.0 μF, 440VAC	

## Note:

- Specifications are subjected to change without prior notice for further improvement.

### 3.2. CS-A9DKD CU-A9DKD

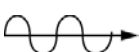
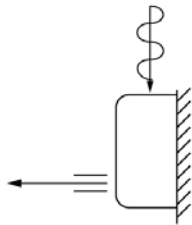
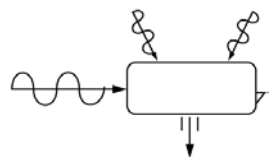
		Unit	Indoor Unit	Outdoor Unit
Power Source (Phase, Voltage, Cycle)		ø, V, Hz	Single, 220 - 230, 50	
Cooling Capacity		kW (BTU/h)	2.65 - 2.65 (9,040 - 9,040)	
Heating Capacity		kW (BTU/h)	2.80 - 2.85 (9,550 - 9,720)	
Moisture Removal		l/h (Pint/h)	1.6 (3.4)	
Airflow Method		<p>OUTLET</p>  <p>INTAKE</p> 	<p>SIDE VIEW</p> 	<p>TOP VIEW</p> 
Air Volume	Lo	m <sup>3</sup> /min (cfm)	Cooling; 5.8 (204) - 5.8 (204) Heating; 6.2 (220) - 6.2 (220)	—
	Me	m <sup>3</sup> /min (cfm)	Cooling; 7.1 (251) - 7.1 (251) Heating; 7.1 (251) - 7.1 (251)	—
	Hi	m <sup>3</sup> /min (cfm)	Cooling; 8.6 (300) - 8.6 (300) Heating; 9.4 (330) - 9.4 (330)	Cooling; 29.5 (1,040) - 30.0 (1,060)
	SHi	m <sup>3</sup> /min (cfm)	Cooling; 9.4 (333) - 9.4 (333) Heating; —	—
Noise Level		dB (A)	Cooling; High 36 - 36, Low 26 - 26 Heating; High 38 - 38, Low 28 - 28	Cooling; High 48 - 49 Heating; High 48 - 49
		Power level dB	Cooling; High 49 - 49 Heating; High 51 - 51	Cooling; High 63 - 64 Heating; High 64 - 65
Electrical Data	Input Power	kW	Cooling; 0.83 - 0.86 Heating; 0.70 - 0.74	
	Running Current	A	Cooling; 3.9 - 3.9 Heating; 3.3 - 3.3	
	EER	W/W (BTU/hW)	Cooling; 3.19 - 3.08 (10.9 - 10.5)	
	COP	- (BTU/hW)	Heating; 4.00 - 3.85 (13.6 - 13.1)	
	Starting Current	A	18.0	
Piping Connection Port (Flare piping)		inch inch	G ; Half Union 3/8" L ; Half Union 1/4"	G ; 3-way valve 3/8" L ; 2-way valve 1/4"
Pipe Size (Flare piping)		inch inch	G ; (gas side) 3/8" L ; (liquid side) 1/4"	G ; (gas side) 3/8" L ; (liquid side) 1/4"
Drain Hose	Inner diameter	mm	12	—
	Length	mm	650	—
Power Cord	Length	m	1.9	—
	Number of core-wire		3 (1.5 mm <sup>2</sup> )	—
Dimensions	Height	inch (mm)	11 - 1/32 (280)	20 - 3/32 (510)
	Width	inch (mm)	31 - 15/32 (799)	25 - 19/32 (650)
	Depth	inch (mm)	7 - 7/32 (183)	9 - 1/16 (230)
Net Weight		lb (kg)	20 (9.0)	60 (27)
Compressor	Description		—	Rotary (1 cylinder) rolling piston type
	Motor Type		—	Induction (2-poles)
	Rated Output	W	—	750



		Unit	Indoor Unit	Outdoor Unit	
Fan Motor	Description		Cross-flow Fan	Propeller Fan	
	Material		AS + Glass Fiber 20%	PP Resin	
	Type		Induction (4-poles)	Induction (6-poles)	
	Input	W	60.5 - 66.0	66 - 74.8	
	Rated	Output	W	15	30
	Fan Speed	Low	rpm	Cooling; 780 - 780 Heating; 840 - 840	—
		Medium	rpm	Cooling; 960 - 960 Heating; 960 - 960	—
High		rpm	Cooling; 1,160 - 1,160 Heating; 1,270 - 1,270	800 - 830	
SuperHigh		rpm	Cooling; 1,270 - 1,220 Heating; —	—	
Heat Exchanger	Description		Evaporator	Condenser	
	Tube material		Copper	Copper	
	Fin material		Aluminium (Pre Coat)	Aluminium (Blue Coat)	
	Fin Type		Slit Fin	Corrugated Fin	
	Row / Stage		(Plate fin configuration, forced draft)		
			2 × 15	2 × 23	
	FPI		19	17	
Size (W × H × L)	mm	610 × 315 × 25.4	585.7 × 484 × 36.4 557.1		
Refrigerant Control Device			—	Capillary Tube	
Refrigeration Oil		(cm <sup>3</sup> )	—	ATMOS M60 OR SUNISO 4GDID	
Refrigerant (R22)		g (oz)	—	730 (25.8)	
Thermostat			—	—	
Protection Device			—	Overload Protector	
Capillary Tube	Length	mm	—	Cooling; 890, Heating; 890	
	Flow Rate	l/min	—	Cooling; 9.5, Heating; 9.5	
	Inner Diameter	mm	—	Cooling; 1.5, Heating; 1.5	
Air Filter	Material		P.P.	—	
	Style		Honeycomb	—	
Capacity Control			Capillary Tube		
Compressor Capacitor		μF, VAC	—	30 μF, 370VAC	
Fan Motor Capacitor		μF, VAC	1.5 μF, 440VAC	2.0 μF, 440VAC	

## Note:

- Specifications are subjected to change without prior notice for further improvement.

### 3.3. CS-A12DKD CU-A12DKD

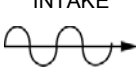
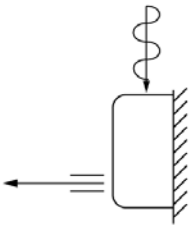
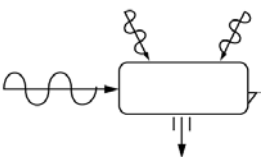
		Unit	Indoor Unit	Outdoor Unit
Power Source (Phase, Voltage, Cycle)		ø, V, Hz	Single, 220 - 230, 50	
Cooling Capacity		kW (BTU/h)	3.52 - 3.54 (12,000 - 12,100)	
Heating Capacity		kW (BTU/h)	4.00 - 4.05 (13,650 - 13,810)	
Moisture Removal		l/h (Pint/h)	2.0 (4.2)	
Airflow Method		<p>OUTLET</p>  <p>INTAKE</p> 	<p>SIDE VIEW</p> 	<p>TOP VIEW</p> 
Air Volume	Lo	m <sup>3</sup> /min (cfm)	Cooling; 6.7 (236) - 6.7 (236) Heating; 7.1 (251) - 7.1 (251)	—
	Me	m <sup>3</sup> /min (cfm)	Cooling; 8.3 (294) - 8.3 (294) Heating; 8.3 (293) - 8.3 (293)	—
	Hi	m <sup>3</sup> /min (cfm)	Cooling; 9.5 (340) - 9.5 (340) Heating; 9.7 (340) - 9.7 (340)	Cooling; 32.5 (1,150) - 33.5 (1,180)
	SHi	m <sup>3</sup> /min (cfm)	Cooling; 9.7 (343) - 9.7 (343) Heating; —	—
Noise Level		dB (A)	Cooling; High 39 - 39, Low 29 - 29 Heating; High 40 - 40, Low 29 - 29	Cooling; High 48 - 49 Heating; High 48 - 49
		Power level dB	Cooling; High 52 - 52 Heating; High 53 - 53	Cooling; High 63 - 64 Heating; High 64 - 65
Electrical Data	Input Power	kW	Cooling; 1.08 - 1.15 Heating; 1.09 - 1.12	
	Running Current	A	Cooling; 5.1 - 5.1 Heating; 5.2 - 5.1	
	EER	W/W (BTU/hW)	Cooling; 3.26 - 3.16 (11.1 - 10.8)	
	COP	W/W (BTU/hW)	Heating; 3.67 - 3.62 (12.5 - 12.3)	
	Starting Current	A	27.0	
Piping Connection Port (Flare piping)		inch inch	G ; Half Union 1/2" L ; Half Union 1/4"	G ; 3-way valve 1/2" L ; 2-way valve 1/4"
Pipe Size (Flare piping)		inch inch	G ; (gas side) 1/2" L ; (liquid side) 1/4"	G ; (gas side) 1/2" L ; (liquid side) 1/4"
Drain Hose	Inner diameter	mm	12	—
	Length	mm	650	—
Power Cord	Length	m	1.9	—
	Number of core-wire		3 (1.5 mm <sup>2</sup> )	—
Dimensions	Height	inch (mm)	11 - 1/32 (280)	21 - 1/4 (540)
	Width	inch (mm)	31 - 15/32 (799)	30 - 23/32 (780)
	Depth	inch (mm)	7 - 7/32 (183)	11 - 3/8 (289)
Net Weight		lb (kg)	20 (9.0)	82 (37)
Compressor	Description		—	Rotary (1 cylinder) rolling piston type
	Motor Type		—	Induction (2-poles)
	Rated Output	W	—	950

		Unit	Indoor Unit	Outdoor Unit	
Fan Motor	Description		Cross-flow Fan	Propeller Fan	
	Material		AS + Glass Fiber 20%	PP Resin	
	Motor Type		Induction (4-poles)	Induction (6-poles)	
	Input	W	60.5 - 66.0	71.5 - 80.3	
	Rated Output	W	15	31	
	Fan Speed	Low	rpm	Cooling; 900 - 900 Heating; 960 - 960	—
		Medium	rpm	Cooling; 1,120 - 1,120 Heating; 1,120 - 1,120	—
High		rpm	Cooling; 1,280 - 1,280 Heating; 1,310 - 1,310	845 - 860	
SuperHigh		rpm	Cooling; 1,310 - 1,310 Heating; —	—	
Heat Exchanger	Description		Evaporator	Condenser	
	Tube material		Copper	Copper	
	Fin material		Aluminium (Pre Coat)	Aluminium (Blue Coat)	
	Fin Type		Slit Fin	Corrugated Fin	
	Row / Stage		(Plate fin configuration, forced draft)		
			2 × 15	2 × 24	
	FPI		21	16	
Size (W × H × L)	mm	610 × 315 × 25.4	720 × 504 × 36.38		
Refrigerant Control Device			—	Capillary Tube	
Refrigeration Oil		(cm <sup>3</sup> )	—	ATMOS M0 OR SUNISO 4GDID	
Refrigerant (R-22)		g (oz)	—	1,080 (38.1)	
Thermostat			—	—	
Protection Device			—	—	
Capillary Tube	Length	mm	—	Cooling; 630, Heating; 455	
	Flow Rate	l/min	—	Cooling; 6.5, Heating; 13.6	
	Inner Diameter	mm	—	Cooling; 1.2 Heating; 1.5	
Air Filter	Material		P.P.	—	
	Style		Honeycomb	—	
Capacity Control			Capillary Tube		
Compressor Capacitor		μF, VAC	—	35 μF, 370VAC	
Fan Motor Capacitor		μF, VAC	1.5 μF, 440VAC	2.0 μF, 440VAC	

## Note:

- Specifications are subjected to change without prior notice for further improvement.

# 4 Dimensions

## 4.1. Indoor Unit & Remote Control

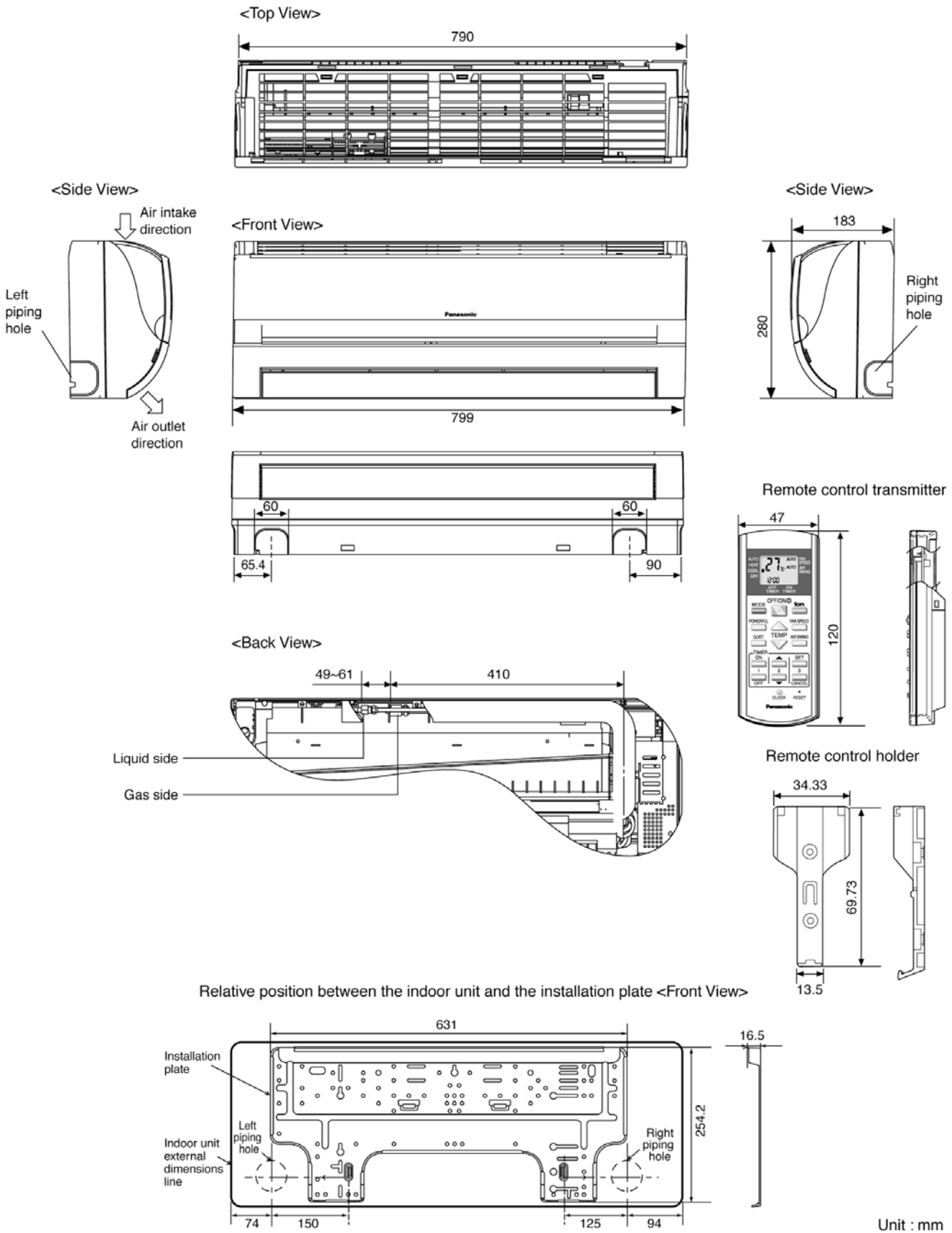

## 4.2. Outdoor Unit

### 4.2.1. CU-A7DKD / CU-A9DKD

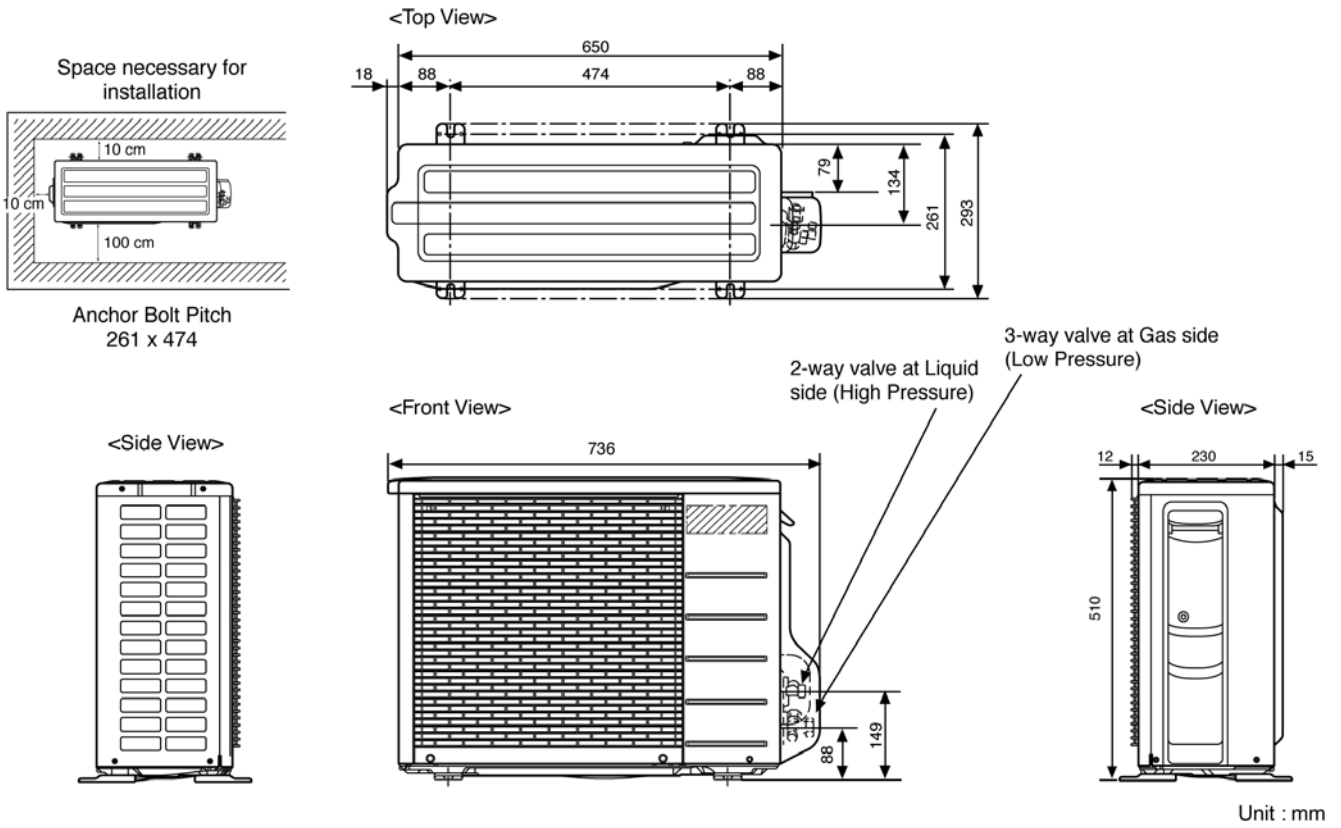

### 4.2.2. CU-A12DKD

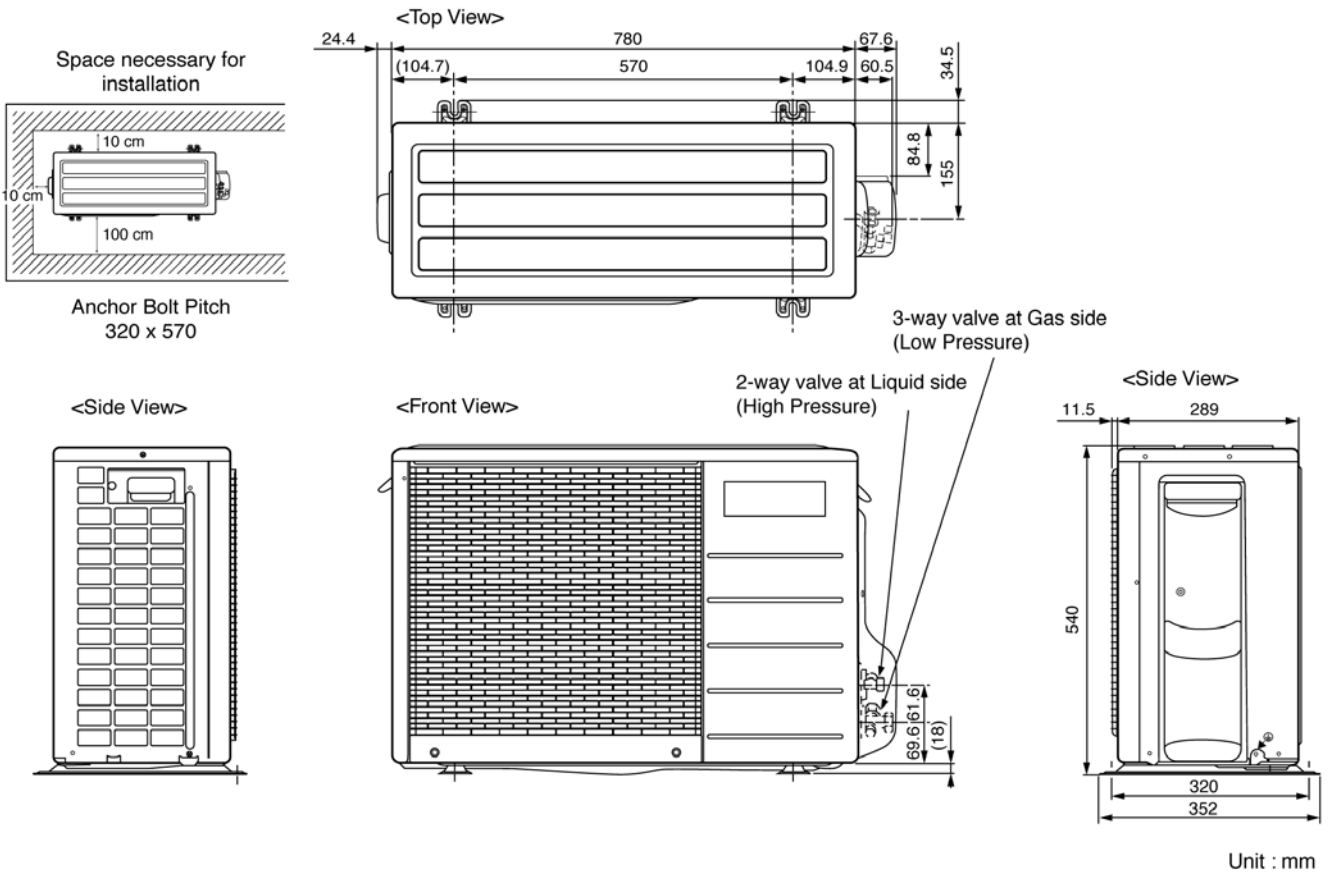

# 5 Refrigeration Cycle Diagram

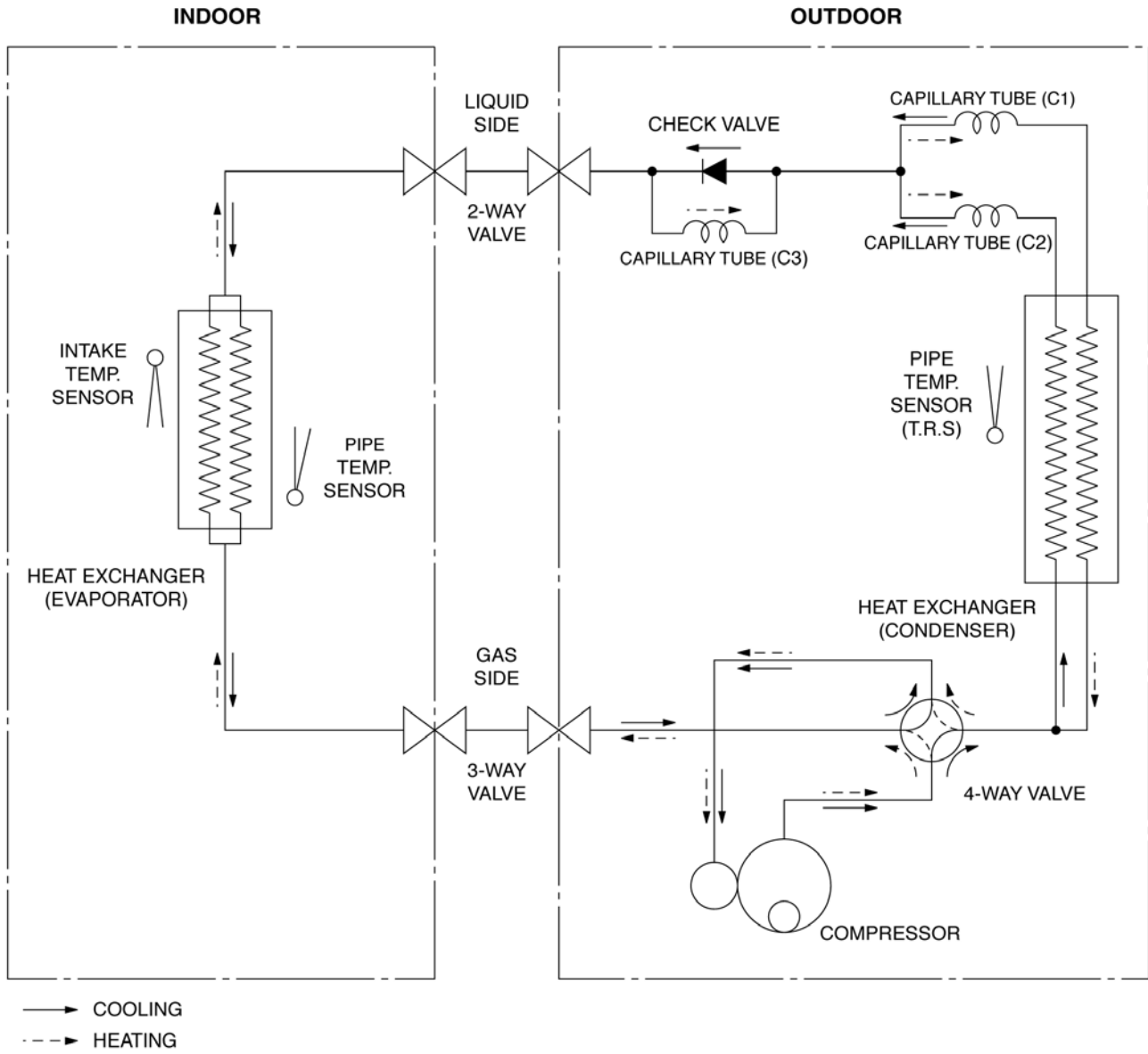

# 6 Block Diagram

CS-A7DKD CU-A7DKD  
CS-A9DKD CU-A9DKD

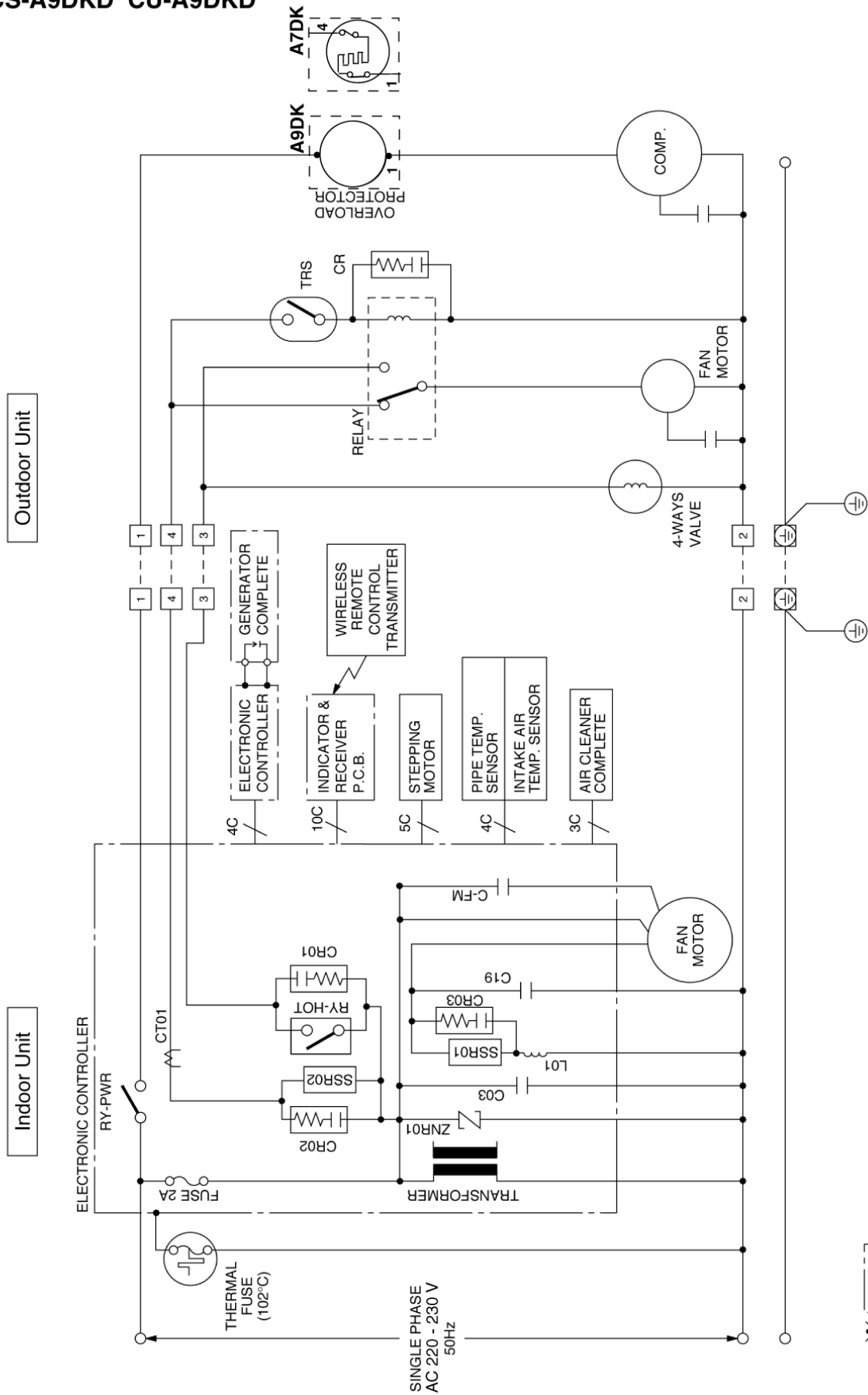

⊠ Indicates the electronic control unit.

✱✱ "C" Indicates the number of core wires. (Example: 4C=4 core wires)

# CS-A12DKD CU-A12DKD

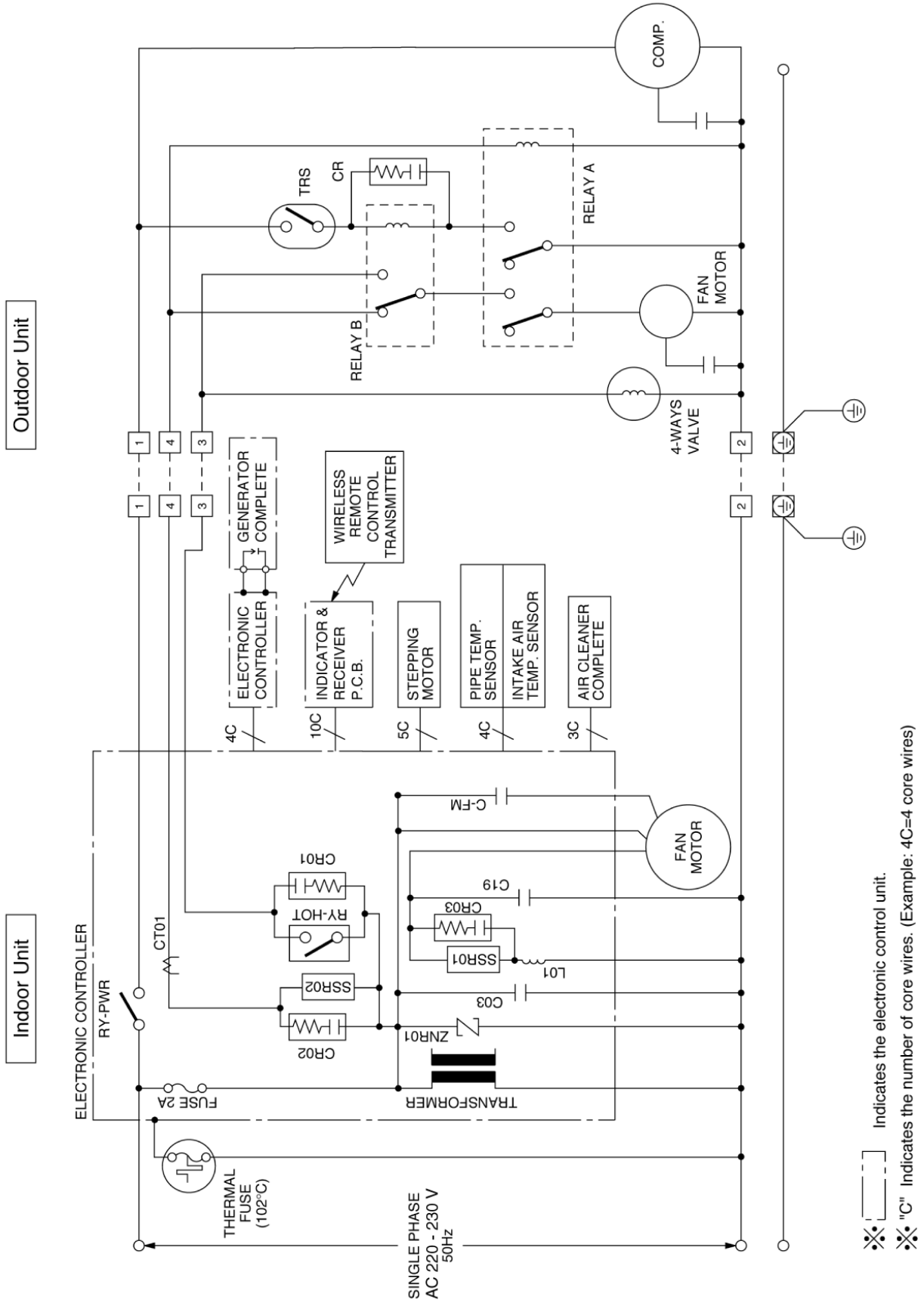



# 7 Wiring Diagram

**CS-A7DKD CU-A7DKD**  
**CS-A9DKD CU-A9DKD**

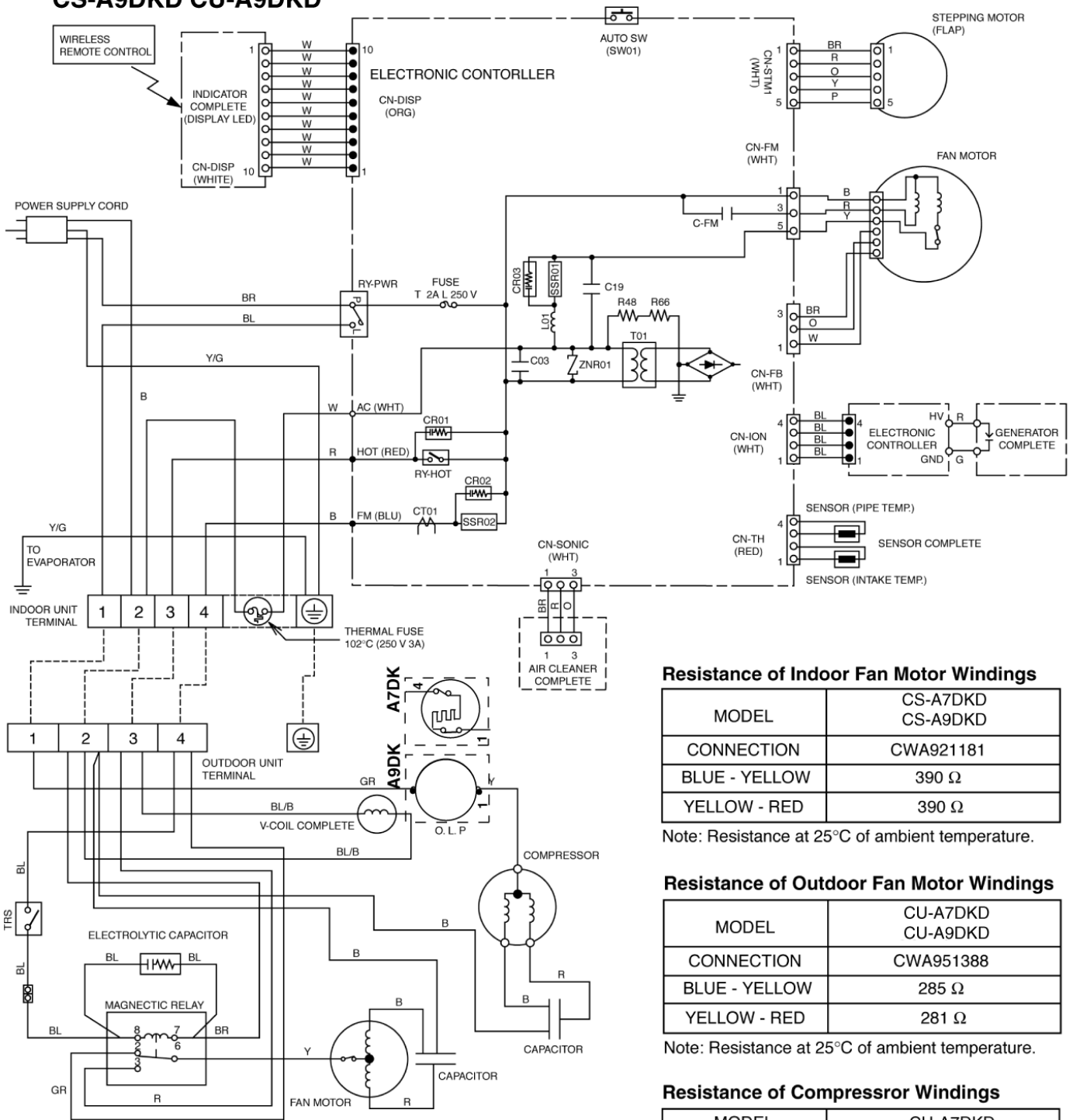

- Remarks:**
- B : BLUE
  - BR : BROWN
  - BL : BLACK
  - GR : GRAY
  - O : ORANGE
  - P : PINK
  - R : RED
  - W : WHITE
  - Y/G : YELLOW / GREEN

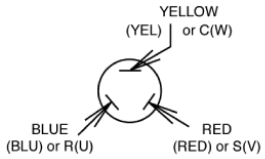

**Resistance of Indoor Fan Motor Windings**

MODEL	CS-A7DKD CS-A9DKD
CONNECTION	CWA921181
BLUE - YELLOW	390 Ω
YELLOW - RED	390 Ω

Note: Resistance at 25°C of ambient temperature.

**Resistance of Outdoor Fan Motor Windings**

MODEL	CU-A7DKD CU-A9DKD
CONNECTION	CWA951388
BLUE - YELLOW	285 Ω
YELLOW - RED	281 Ω

Note: Resistance at 25°C of ambient temperature.

**Resistance of Compressor Windings**

MODEL	CU-A7DKD
CONNECTION	2RS122D5BC02
C - R	5.193 Ω
C - S	5.557 Ω

Note: Resistance at 25°C of ambient temperature.

MODEL	CU-A9DKD
CONNECTION	2PS156D3BB02
C - R	3.501 Ω
C - S	3.405 Ω

Note: Resistance at 25°C of ambient temperature.

# CS-A12DKD CU-A12DKD

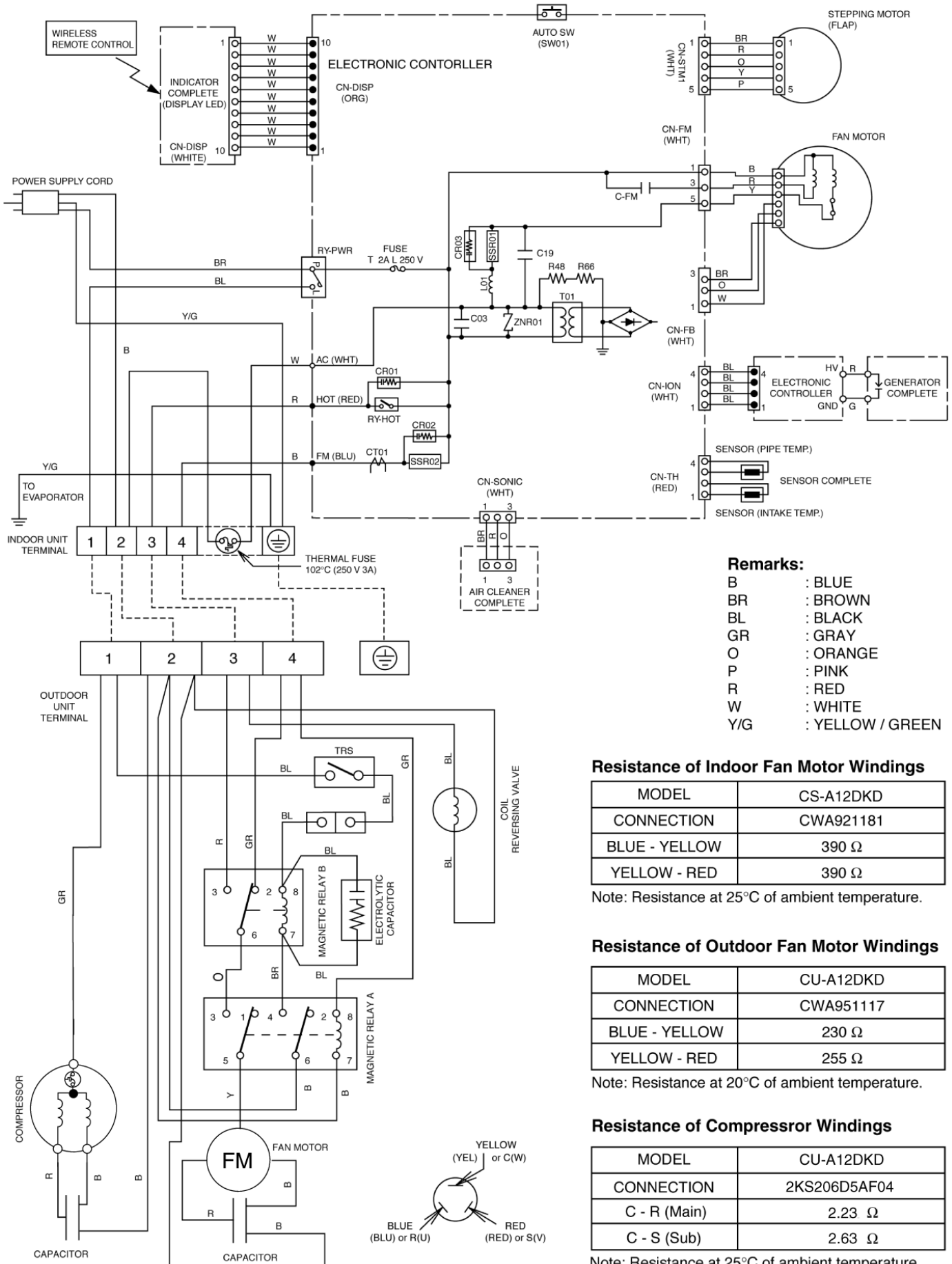

- Remarks:**
- B : BLUE
  - BR : BROWN
  - BL : BLACK
  - GR : GRAY
  - O : ORANGE
  - P : PINK
  - R : RED
  - W : WHITE
  - Y/G : YELLOW / GREEN

**Resistance of Indoor Fan Motor Windings**

MODEL	CS-A12DKD
CONNECTION	CWA921181
BLUE - YELLOW	390 Ω
YELLOW - RED	390 Ω

Note: Resistance at 25°C of ambient temperature.

**Resistance of Outdoor Fan Motor Windings**

MODEL	CU-A12DKD
CONNECTION	CWA951117
BLUE - YELLOW	230 Ω
YELLOW - RED	255 Ω

Note: Resistance at 20°C of ambient temperature.

**Resistance of Compressor Windings**

MODEL	CU-A12DKD
CONNECTION	2KS206D5AF04
C - R (Main)	2.23 Ω
C - S (Sub)	2.63 Ω

Note: Resistance at 25°C of ambient temperature.

# 8 Operation Details

## 8.1. Heating Operation

- Heating operation can be set using remote control.
- This operation is applied to warm the room temperature reaches the setting temperature set on the remote control.
- The remote control setting temperature, which takes the reading of intake air temperature sensor, can be adjusted from 16°C to 30°C.
- During heating operation, the compressor will stop running and restart as shown in below figure.

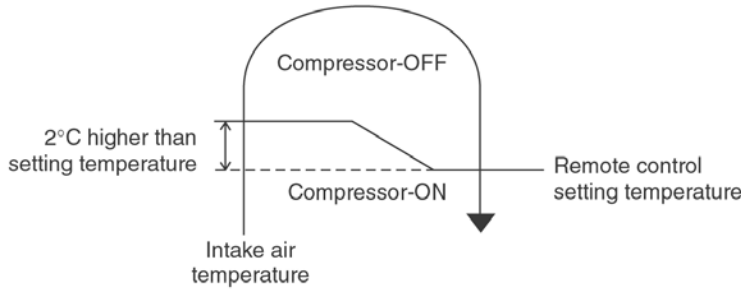

### 8.1.1. Heating Operation Time Diagram

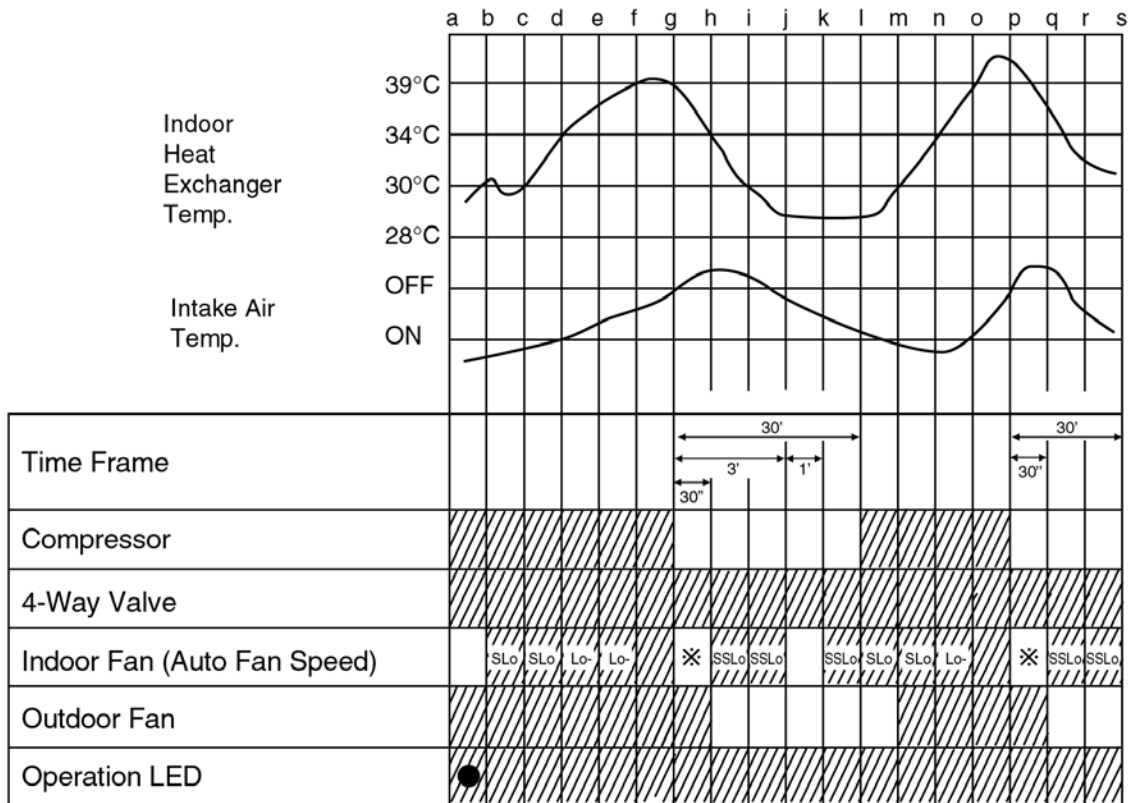

<Description of operation>

a - f, l - o : Hot start

g - l : 30 Minutes Time Save Control/Anti Cold Draft Control

g - h, p - q : Outdoor Fan Motor Control (30 sec. Forced Operation) after compressor stops.

● : Blinking

※ : Fan Speed will follow Indoor heat exchanger temperature.

▨ : Operation

□ : Stop

## 8.2. Cooling Operation

- Cooling operation can be set using remote control.
- This operation is applied to cool down the room temperature reaches the setting temperature set on the remote control.
- The remote control setting temperature, which takes the reading of intake air temperature sensor, can be adjusted from 16°C to 30°C.
- During cooling operation, the compressor will stop running and restart as shown in below figure.

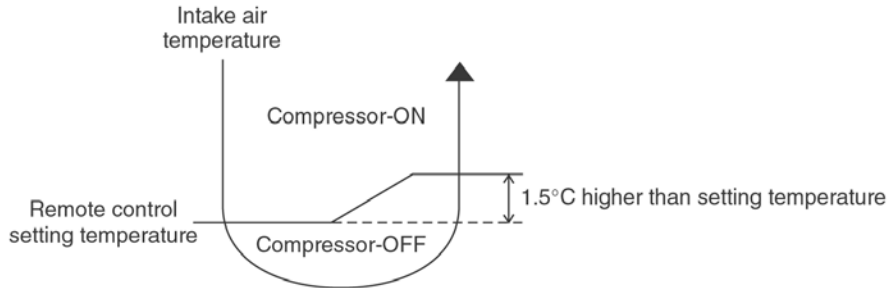

### 8.2.1. Cooling Operation Time Diagram

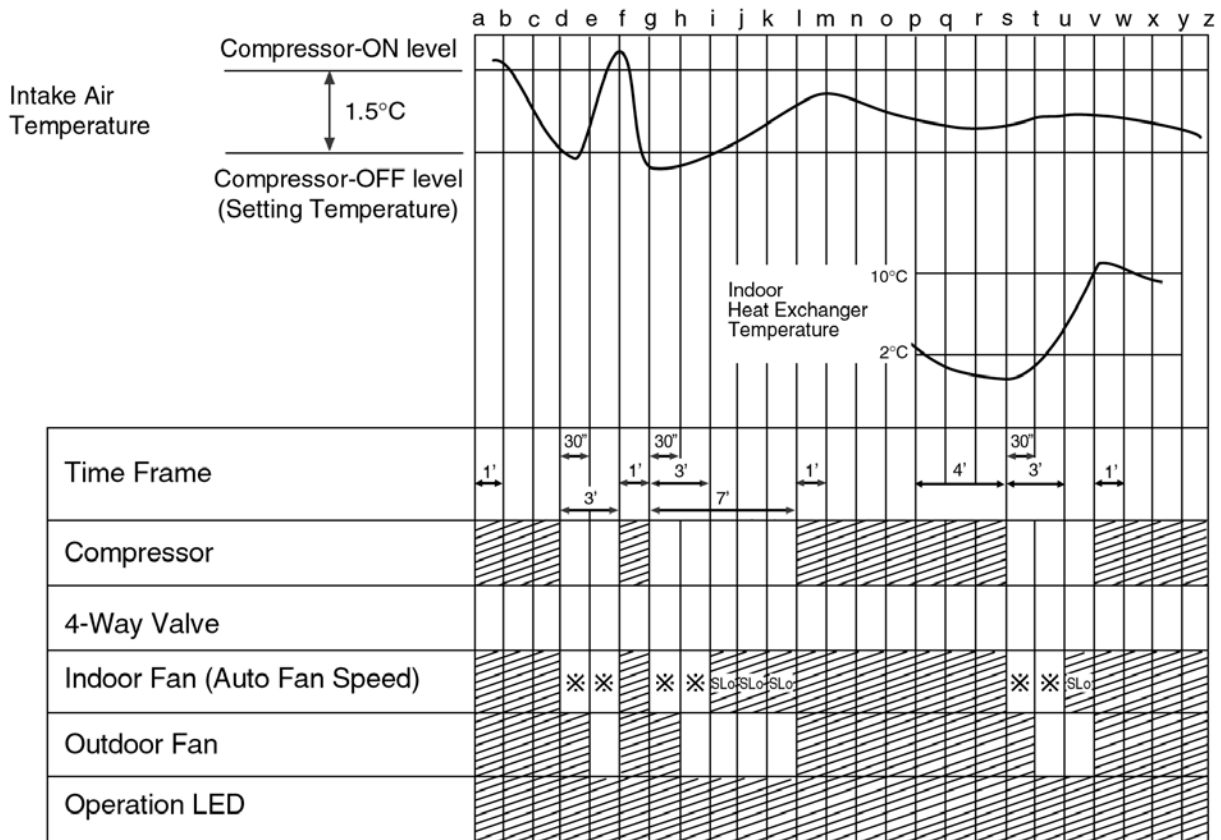

<Description of operation>

- a – b, f – g, l – m, v – w : Minimum 60 seconds forced operation
- d – f, g – i, s – u : Minimum 3 minutes restart control (Time Delay Safety Control)
- g – l : Maximum 7 minutes time save control
- p – v : Anti-Freezing Control
- d – e, g – h, s – t : Outdoor Fan Motor Control (30 sec. Forced Operation) after compressor stops
- (※) d – f, g – i, s – u : Indoor fan rotates at SLo for 20 seconds and off for 160 seconds.



### 8.3. Soft Dry Operation

- Soft Dry operation can be set using remote control.
- Soft Dry operation is applied to dehumidify and to perform a gentle cooling to the room.
- This operation starts when the intake air temperature sensor reaches the setting temperature on the remote control.
- When operation begins, Soft Dry will be switched "ON" for a maximum 10 minutes, then Soft Dry operation will be turned "OFF" for a minimum 6 minutes. After that, the Soft Dry operation will be "ON" and "OFF" based on the setting temperature as shown in below figure.
- However after 3 minutes of compressor off, during Soft Dry "OFF" (within 6 minutes Soft Dry restart control), the indoor unit will start to operate at normal Cooling mode if the intake temperature is higher than Cooling "ON" point.

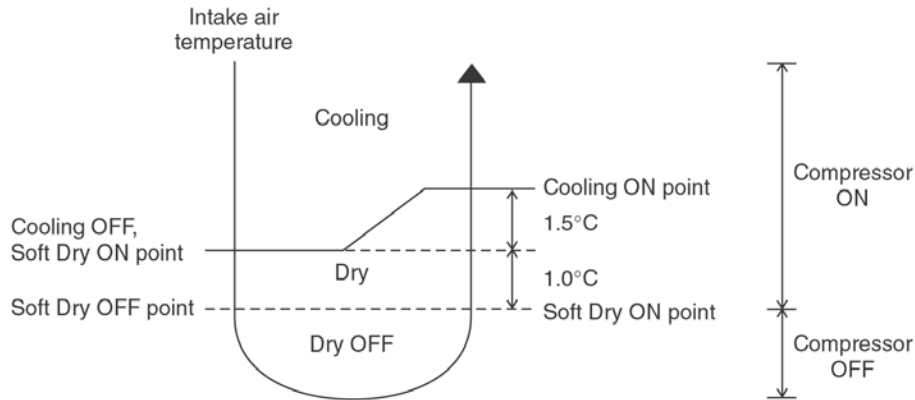

#### 8.3.1. Soft Dry Operation Time Diagram

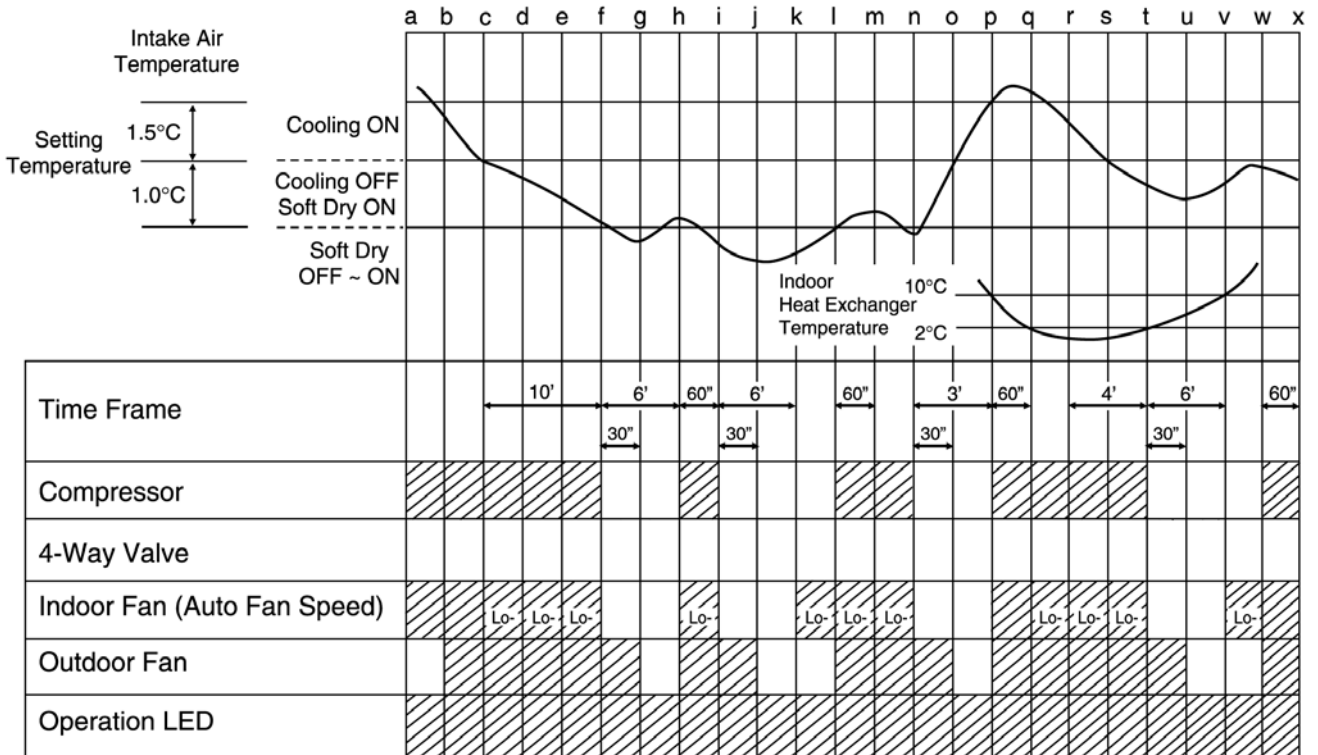

<Description of operation>

- h - i, l - m, p - q, w - x : Minimum 60 seconds forced operation
- n - p : Minimum 3 minutes restart control (Time Delay Safety Control) - Cooling operation
- f - h, i - k, t - v : Minimum 6 minutes restart control (Time Delay Safety Control) - Soft dry operation
- r - w : Anti-Freezing Control
- f - g, i - j, n - o, t - u : Outdoor Fan Motor Control

 Operation  
 Stop

## 8.4. Automatic Operation

- Automatic operation can be set using remote control.
- This operation starts to operate with indoor fan at SLo speed for 25 seconds to judge the intake air temperature.
- After judged the temperature, the operation mode is determined by referring to the below standard.

↑ Intake Air Temperature	23°C	Cooling Operation
	20°C	Soft Dry Operation
		Heating Operation

- Then, the unit start to operate at determined operation mode, until it is switched off using remote control, with the setting temperature as shown in below table.

	Setting Temperature (Standard)
Cooling Operation	25°C
Soft Dry Operation	22°C
Heating Operation	21°C

- Operation mode will be determine again for judgement after 1 hour of operation, if the room temperature reaches to set temperature and compressor off time is over 7 minutes 30 seconds continuously.
- ✗ The present operation mode will be continued, if the room temperature does not reach to set temperature (Compressor keeps running) eventhough after 1 hour from automatic operation mode started.

### Standard for Determining Operation Mode 2nd Judgement onwards

Present Mode	Judgement	Next Mode		
		Cooling	Soft Dry	Heating
Cooling	23°C   <u>Cooling</u>   <u>Heating</u>	○ (Judgement: 23°C & Above)	Not Applicable	○ (Judgement: Below 23°C)
Soft Dry	20°C   <u>Soft Dry</u>   <u>Heating</u>	Not Applicable	○ (Judgement: 20°C & Above)	○ (Judgement: Below 20°C)
Heating	25°C   <u>Cooling</u>   <u>Heating</u>	○ (Judgement: Above 25°C)	Not Applicable	○ (Judgement: 25°C & below)

- ✗ Automatic Set Temperature Refer as below.

#### • Automatic Set Temperature

For each operation, set temperature will automatically set as shown below.

However it can be selected 2°C higher or 2°C lower from standard set temperature by pressing the “Room Temperature Setting button”.

Operation	Hi	(Standard)	Lo
	(+2°C)	(±0°C)	(-2°C)
Cooling	27°C	25°C	23°C
Soft Dry	24°C	22°C	20°C
Heating	23°C	21°C	19°C

- The setting temperature for all the operations can be changed one level up or one level down from the standard temperature as shown in below table by pressing on the temperature up or temperature down button at remote control.

	Cooling	Soft Dry	Heating
Higher → +2°C	27°C	24°C	23°C
Standard → ±0°C	25°C	22°C	21°C
Lower → -2°C	23°C	20°C	19°C

- The operation mode judging temperature and standard setting temperature can be increased by 2°C permanently, by open the circuit of JX1 at indoor electronic controller.

↑ Intake Air Temperature	25°C	Cooling Operation
	22°C	Soft Dry Operation
		Heating Operation

	Setting Temperature (Standard)
Cooling Operation	27°C
Soft Dry Operation	24°C
Heating Operation	23°C

## 8.5. Operation Control

### 8.5.1. Restart Control (Time Delay Safety Control)

- When the thermo-off temperature (temperature which compressor stops to operate) is reached during:-
  - Cooling/Heating operation - the compressor stops for 3 minutes (minimum) before resume operation.
  - Soft Dry operation - the compressor stops for 6 minutes (minimum) before resume operation.
- If the operation is stopped by the remote control, the compressor will not turn on within 3 minutes from the moment operation stop, although the unit is turn on again within the period.
- This phenomenon is to balance the pressure inside the refrigerant cycle.

### 8.5.2. Compressor Reverse Rotation Protection Control

- If the compressor is operating continuously for 5 minutes or longer and the temperature difference between intake air and indoor heat exchanger is 2.5°C (cooling mode)/5°C (heating mode) or less for continuous 2 minutes, compressor will stop and restart automatically.
- Time Delay Safety Control is activated before the compressor restart.



s T = Intake air temperature - Indoor heat exchanger temperature

- This is to prevent compressor from rotate reversely when there is an instantaneous power failure.

(For 8.5.3. to 8.5.7. information applies only to Cooling and Soft Dry Operation)

### 8.5.3. 7 Minutes Time Save Control

- The compressor will start automatically if it has stopped for 7 minutes and the intake air temperature falls between the compressor ON temperature (A) and compressor OFF temperature (B) during the period.
- This phenomenon is to reduce the built up humidity inside a room.

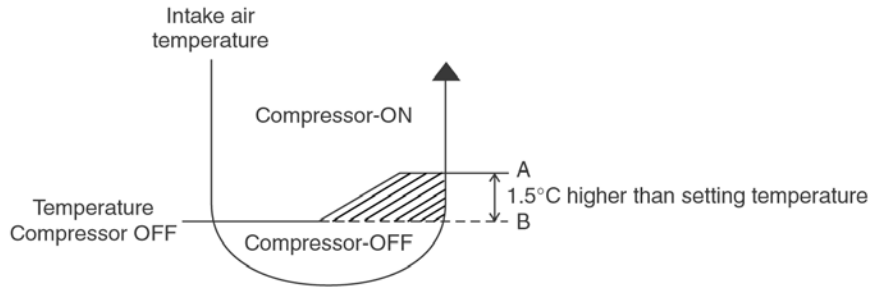

### 8.5.4. 60 Seconds Forced Operation

- Once the air conditioner is turned on, the compressor will not stop within 60 seconds in a normal operation although the intake air temperature has reached the thermo-off temperature. However, force stop by pressing the OFF/ON operation button at the remote control is permitted.
- The reason for the compressor to force operate at minimum 60 seconds is to allow the refrigerant oil run in a full cycle and return back to the outdoor unit.

### 8.5.5. Starting Current Control

- When the compressor, outdoor fan motor and indoor fan motor are simultaneously started, the indoor fan motor will start to operate at 1.6 second later.
- The reason of the difference is to reduce the starting current flow.

### 8.5.6. Anti-Freezing Control

- If the temperature of the indoor heat exchanger falls below 2°C continuously for 4 minutes or more, the compressor turns off. The fan speed setting remains the same.
- This phenomenon is to protect the indoor heat exchanger from freezing and to prevent higher volume of refrigerant in liquid form returning to the compressor.
- Compressor will restart again when the indoor heat exchanger temperature rises to 10°C (Recovery).
- Restart control (Time Delay Safety Control) will be applied in this Control if the recovery time is too short.

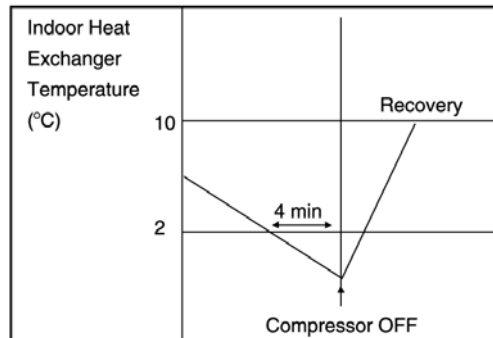



(For 8.5.8. to 8.5.14. information applies only to Heating Operation)

### 8.5.7. Anti-Dew Formation Control

- Purpose is to prevent dew formation on indoor unit air discharge area.
- When room temperature is constant ( $\pm 1^{\circ}\text{C}$ ) the following conditions occur for 30 minutes continuously, anti-dew formation will activate:
  - Remote Control setting temperature is less than  $25^{\circ}\text{C}$ .
  - Compressor is on.
  - Cooling operation mode.
  - Indoor Fan motor operate at Low fan speed (CLo, Lo- or QLo).
- This control is cancelled immediately when above condition is changed, or Powerful button is pressed.
- Anti-Dew formation is control by:
  1. CLo fan is changed to HLo fan.
  2. QLo fan is changed to HLo fan.

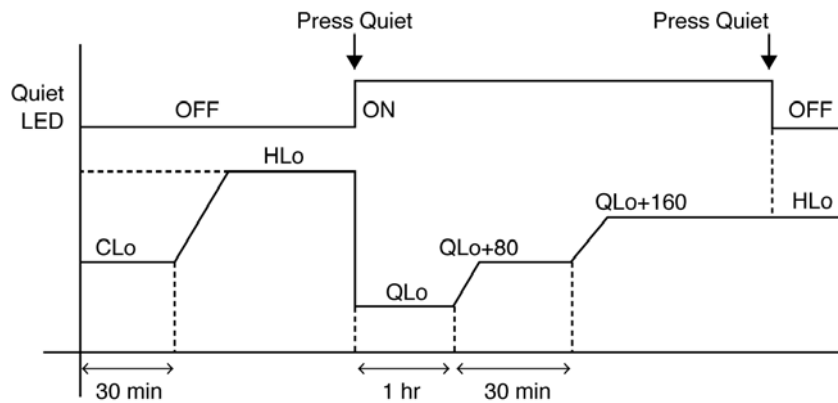

### 8.5.8. 30 Minutes Time Save Control

- The compressor will start automatically if it has stopped for 30 minutes and the intake air temperature falls between the compressor OFF temperature (A) and compressor ON temperature (B) during the period.
- This is to maintain the room temperature as set. Despite of this, it is to prevent a wrong judgement of intake air temperature due to poor installation near the sensor area.

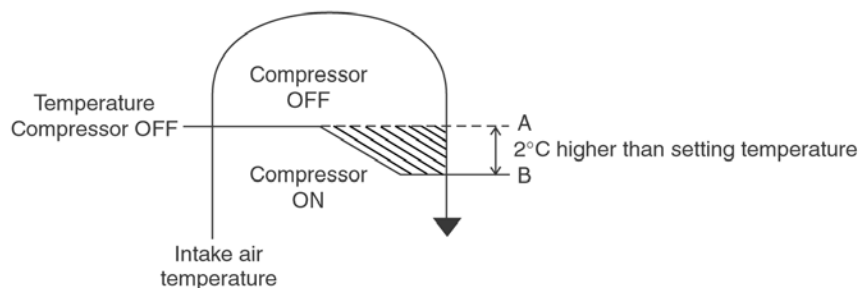

### **8.5.9. Compressor Overload Protection Control**

#### Outdoor Fan Control

- If the temperature of the indoor heat exchanger rises to 51°C, outdoor fan stops. The outdoor fan restarts when the indoor heat exchanger temperature falls to 49°C.

#### Compressor high pressure protection

- If the indoor heat exchanger becomes 65°C or more, the compressor will stop and restart automatically. (Time Delay Safety Control - 4 minutes waiting).
- This is to reduce the pressure, as to reduce the indoor heat exchanger temp. Nevertheless, is to protect the compressor from overload of too high temperature.

### **8.5.10. 4-Way Valve Control**

- 4-way valve always on during Heating operation. (except deicing operation)
- When the unit is switched off by remote control during Heating operation, the 4-way valve stay at Heating position for 5 minutes.
- This is to prevent the refrigerant flow process sound for being occur.

### **8.5.11. Outdoor Fan Motor Control**

- When compressor stops (reaches room temperature), outdoor fan will operate for 30 seconds (forced operation).
- This is to release the heat and to obtain the lowest pressure as fast as possible.

### 8.5.12. Hot Start Control

- Hot Start Control is to prevent cool air discharge into the room when heating operation start.
- When Heating operation starts, Indoor fan will not start until the indoor heat exchanger reaches 30°C as diagram shown.

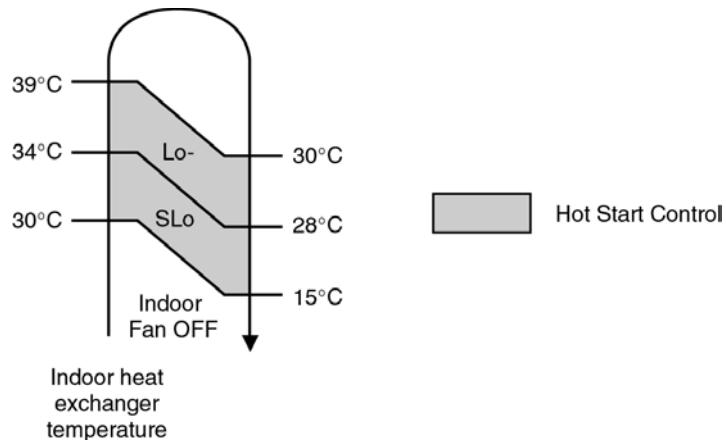

- Hot start is completed when indoor heat exchanger rises to 39°C or operation over 4 minutes.

### 8.5.13. Anti Cold Draft Control

- This operation is to prevent the Cold Draft during Heating mode operation.
- The operation will start when compressor OFF (Thermo OFF) during Heating operation.
- For the first 30 sec. from compressor OFF (Thermo OFF), Indoor fan speed will operate accordingly to the Indoor heat exchanger temperature as shown below:

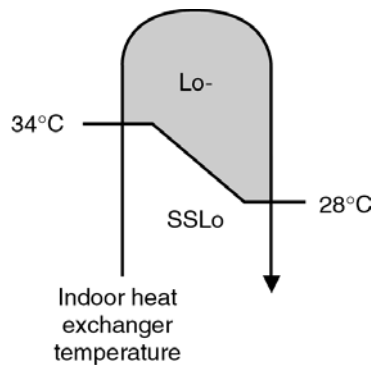

- After 30 sec. from compressor OFF (thermo OFF), Indoor fan will run at SSLo speed only.
- Anti Cold Draft Control will stop when:
  - Intake temperature < set temperature. (Time Delay Safety Control 4 minutes waiting is valid)
  - 30 Minutes Time Save Control activates.

## 8.5.14. Deicing Control

Deice starts to prevent frosting at outdoor heat exchanger.

- Normal Deicing

Deice operations detection commences after 30 minutes of Heating operation starts or 60 minutes after previous deice operation. If the TRS (Thermal Reed Switch) senses the outdoor piping temperature drops to  $-3^{\circ}\text{C}$  (TRS CLOSE) or less for 50 sec. continuously during compressor is in operation, deice will start.

(There is no detection during Outdoor Fan stops.)

- Overload Deicing

During heating operation, if the outdoor Fan OFF duration (due to overload control) is accumulated up to 60 minutes and after compressor starts for 1 minutes, deicing starts.

- Deicing ends when

1. 12 minutes after deicing operation starts;
2. TRS senses the outdoor piping temperature rises to  $4^{\circ}\text{C}$  (TRS OPEN).

⊗ Deicing will not end immediately as time delay (Td) is valid as shown below.

Time taken from deicing starts to TRS OPEN (T)	Deice recovery time	Td (seconds)
$T \leq 1$ minutes	1 min. wait (Min.)	0
1 minutes $< T < 3$ minutes	T	0
3 minutes $< T < 8$ minutes	T + 60 sec.	60
8 minutes $< T < 11$ minutes	T + 120 sec.	120
$T > 11$ minutes	12 min wait (Max.)	—

- Once deicing operation starts, it will not end for 60 seconds.

- After deicing operation, compressor stops for 30 seconds and 4-way valve stays at cooling position for 10 seconds.

**Normal Deicing Time Diagram**

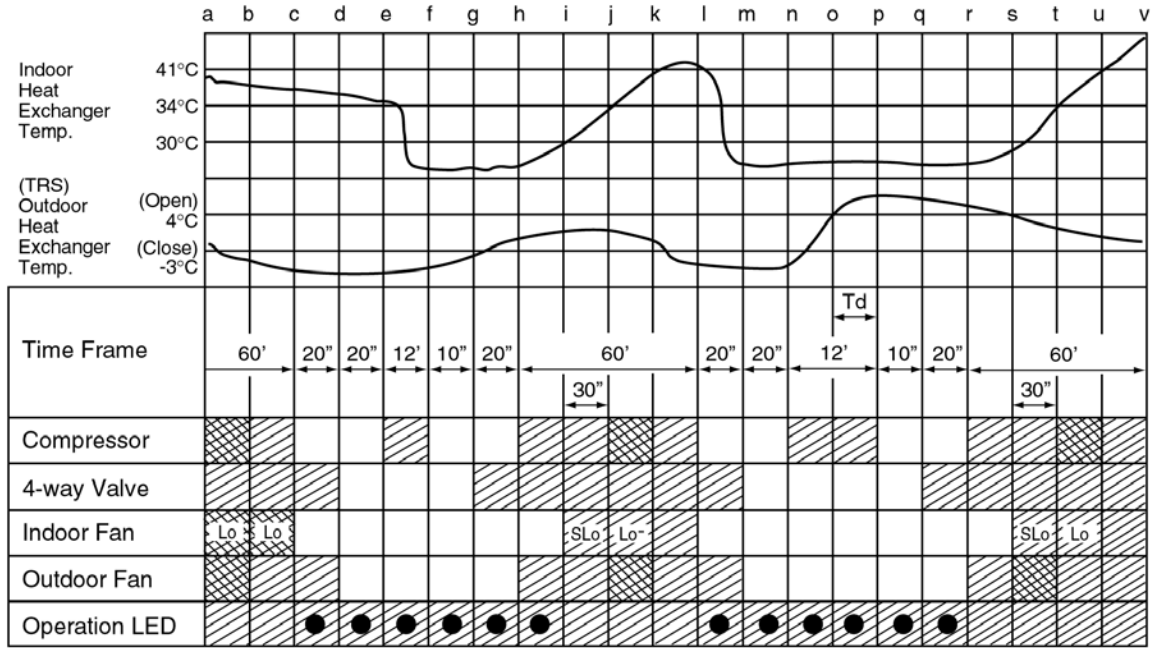

<Description of operation>

- a - c : Deicing operation judging condition established
- c - e, l - n : Deicing operation (timer detected)
- e - h : Deice operation (timer detected)
- h - i, r - s : Hot start (no thermo OFF)
- i - j, s - t : No thermo OFF (after finished hot start)
- n - r : Deicing operation (TRS detected)

- : Blinking
- ▨ : Operation
- : Stop
- ▩ : Operation or Stop
- Td : Time Delay

**Overload Deicing Time Diagram**

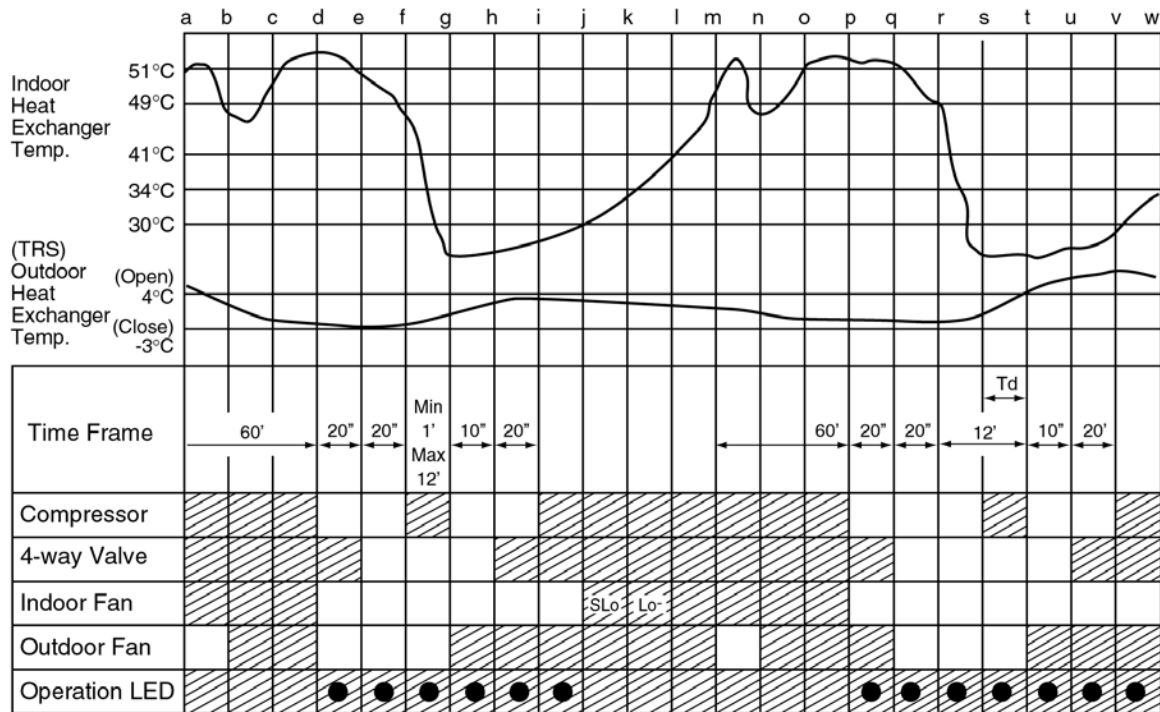

<Description of operation>

- a - d, m - p : Overload control. (intergrate)
- d - f, p - r : Preparation time for Deicing
- f - i : Overload deicing (timer detected)
- i - j : Hot start (indoor fan OFF)
- j - k : Hot start (indoor fan SLo)
- r - t : Overload control (TRS detected)

- : Blinking
- ▨ : Operation
- : Stop
- Td : Time Delay

## 8.6. Indoor Fan Speed Control

- Indoor Fan Speed can be set using remote control.

### 8.6.1. Fan Speed Rotation Chart

Fan Speed (rpm)	CS-A7DKD	CS-A9DKD	CS-A12DKD
S Hi	1220	1270	1310
Hi	1050	1160	1280
Me	920	960	1120
H Lo	840	840	960
C Lo	780	780	880
Lo-	750	750	850
S Lo	700	700	750
SS Lo	300	300	300
Q S Hi	1120	1170	1210
Q Hi	950	1060	1180
Q Me	820	860	1020
Q H Lo	770	770	890
Q Lo	680	680	780

### 8.6.2. Automatic Fan Speed Control

- When set to Auto Fan Speed, the fan speed is adjusted between maximum and minimum setting as shown in the table.
  - Fan speed rotates in the range of Hi, Me and Lo-
  - Deodorizing Control will be activated.

Speed Mode			S Hi	Hi	Me	H Lo	C Lo	Lo-	S Lo	SSLo	Stop	
Cooling	Normal	Manual	Hi	○								
			Me		○							
	Powerful	Auto Volume Auto	Lo				○					
			Auto Volume Auto		○	○			○			○
Dry	Auto Volume Auto	Manual						○			○	
		Auto Volume Auto						○			○	
Heating	Normal	Normal	Hi	○				○			○	
			Me			○		○	○	○	○	
			Lo				○		○	○	○	○
	Powerful	Auto Volume Auto	Auto Volume Auto			○	○		○	○	○	○
			Manual	○		○	○		○	○	○	○
			Auto Volume Auto			○	○		○	○	○	○
Mode judgement		Normal							○			
Cooling	Quiet	Manual	Q Hi		Hi-100							
			Q Me			Me-100						
			Q Lo				CLo-100					
Dry	Quiet	Auto Volume Auto	Auto Volume Auto		Hi-100	Me-100		○			○	
			Manual					○			○	
Heating	Quiet	Manual	Q Hi	SHi-100				○	○	○	○	
			Q Me			Me-100		○	○	○	○	
			Q Lo				HLo-100		○	○	○	○
		Auto Volume Auto			Me-100	HLo-100		○	○	○	○	
Ion	Auto Volume Auto	Manual		○	○		○					
		Auto Volume Auto				○	○					

- Auto Fan Speed during cooling operation:

1. Indoor fan will rotate alternately between off and on as shown in below diagram.
2. At the beginning of each compressor start operation, indoor fan will increase fan speed gradually for deodorizing purpose.
3. For the first time the compressor operate, indoor fan will be switched to Hi fan speed from Lo- after 70 seconds from the start of compressor. This cause the room temperature to achieve the setting temperature quickly.
4. During compressor stop, indoor fan will operate at Lo- for the beginning 20 seconds to prevent higher volume of refrigerant in liquid form returning to the compressor.
5. After the compressor at turn off condition for 3 minutes, indoor fan will start to operate at Lo- to circulate the air in the room. This is to obtain the actual reading of the intake air temperature.
6. When the compressor resume operation, indoor fan will operate at Me fan speed (after 70 seconds from the restart of compressor) to provide comfort and lesser noise environment.

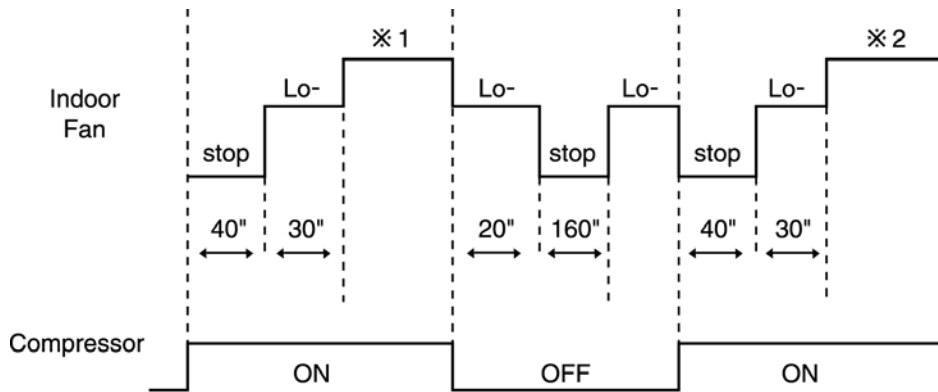

※ 1 Fan Speed is Hi until the compressor stops (when the room temperature reaches setting temperature).

※ 2 Fan Speed is Me after the compressor restarts.

- Auto Fan Speed during Soft Dry operation:

1. Indoor fan will rotate alternately between off and Lo-.
2. At the beginning of each compressor start operation, indoor fan will increase fan speed gradually for deodorizing purpose.
3. When compressor at turn off condition for 6 minutes, indoor fan will start fan speed at Lo- to circulate the air in the room. This is to obtain the actual reading of intake air temperature.

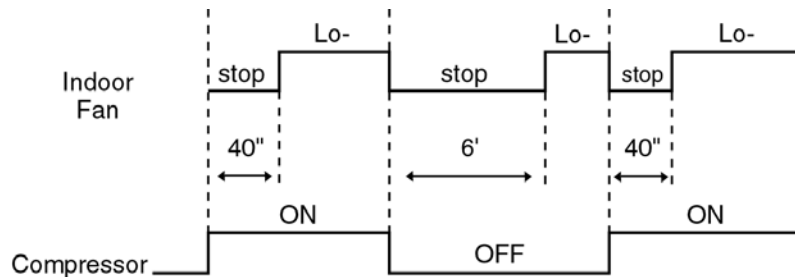

- Auto Fan Speed during Heating operation.

1. Indoor fan will rotate in the range of SLo → Me according to the heat exchanger temperature.

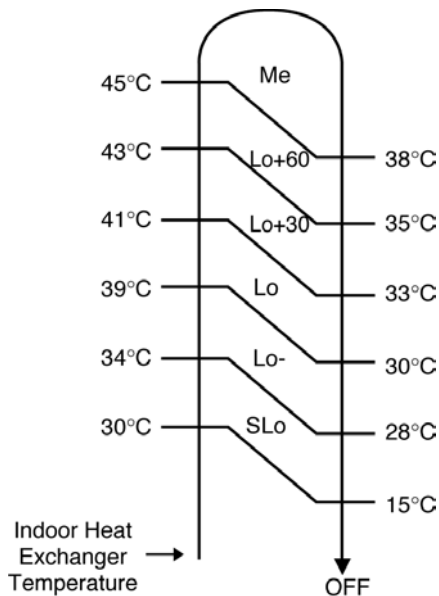

### 8.6.3. Manual Fan Speed Control

- Manual fan speed adjustment can be carried out by using the Fan Speed selection button at the remote control.
- There are 3 types of fan speed settings: Lo, Me, Hi.

## 8.7. Outdoor Fan Speed Control

- There is only one speed for outdoor fan motor.
- When the air conditioner is turned on, the compressor and the outdoor fan will operate simultaneously.
- Likewise, both compressor and outdoor fan will stop at the same time if the unit is turned off.

## 8.8. Vertical Airflow Direction Control

### 8.8.1. Auto Control

(Cooling and Soft Dry Operation condition)

- When the vertical airflow direction is set to Auto using the remote control, the louver swings up and down as shown in the diagram.
- When stop operation using the remote control, the discharge vent is reset, and stop at the closing position.
- During Cooling operation or Soft Dry operation, indoor fan motor may stop to rotate at certain periods. At that condition, the louver will stop swinging and rest at the upper limit.
- During Anti-dew condensation prevention, Airflow Direction Auto-control angle change from 0°-32° to 20°-30° under Cooling and Soft Dry operation mode.

Cooling and Soft Dry Operation

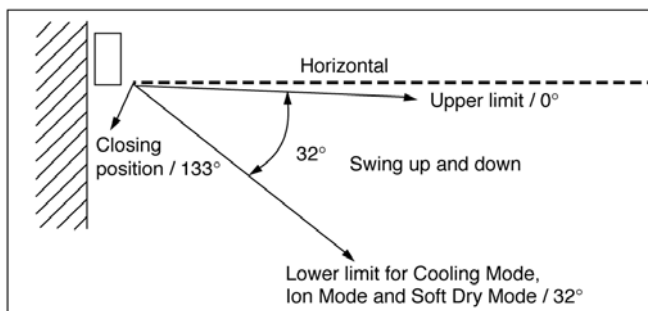



**(Heating Operation condition)**

- When the piping air temperature reaches 38°C, the louver is changed from upper to lower limit. When the piping air temperature falls to 35°C, the louver is changed from lower to upper limit.

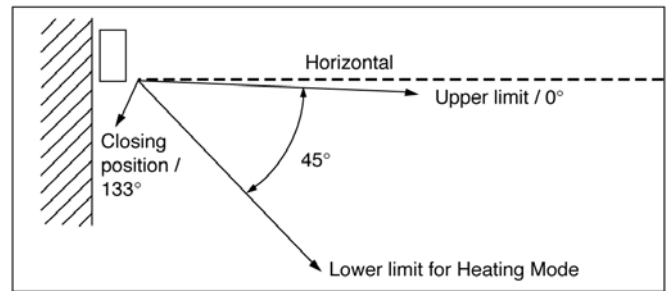
**Heating Operation****8.8.2. Manual Control**

- When the vertical airflow direction is set to Manual using the remote control, the automatic airflow is released and the airflow direction louver move up and down in the range shown in the diagram.
- The louver can be adjusted by pressing the button to the desired louver position.
- When stop operation using the remote control, the discharge vent is reset, and stop at the closing position.
- During Anti-dew condensation prevention, Airflow Direction Manual control angle change from 10°, 15°, 20°, 26°, 32° to 22°, 24°, 26°, 28°, 30° under Cooling and Soft Dry operation mode.

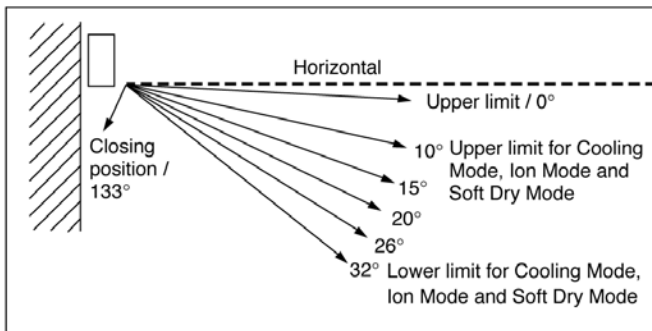
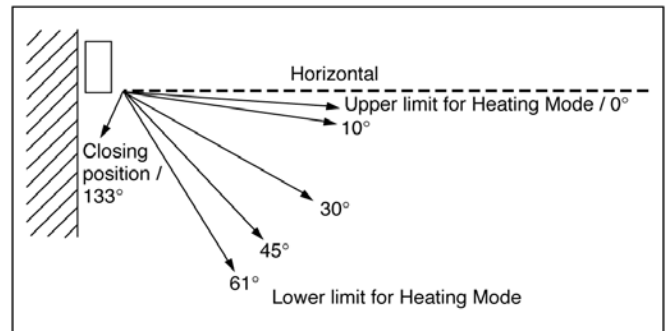
**Cooling and Soft Dry Operation****Heating Operation****8.9. Horizontal Airflow Direction Control**

- The horizontal airflow direction louvers can be adjusted manually by hand.

**8.10. Powerful Operation**

- The Powerful operation is to achieve the setting temperature quickly.

**(Cooling and Soft Dry Operation condition)**

- When Powerful operation is set, the setting temperature will be automatically decreased 3°C internally against the present setting temperature (Lower temperature limit: 16°C).
- This operation automatically will be running under SHi Fan Speed (Cooling).
- Vertical Airflow Direction:-
  - In "Manual" setting, the vane will automatically shift down 10° lower than previous.
  - In "Auto" setting, the vane will automatically swing up and down. However the lower limit will be shifted 10° downward.

**(Heating Operation condition)**

- When Powerful operation is set, the setting temperature will be automatically increased 3°C against the present setting temperature (Higher temperature: 30°C).
- The Fan Speed will shift as shown below:

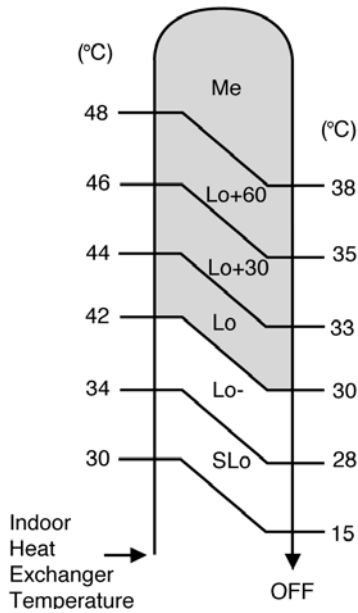

- When the Auto Fan speed is selected, the fan speed will automatically change from SLo to Me depending to the Indoor Heat Exchanger Temperature.
- When the manual Fan Speed is selected, the fan speed will change to the fan speed setting when the Indoor Heat Exchanger Temperature reaches 42°C.

 Set Fan Speed

• Vertical Airflow Direction:-

- In “Manual” setting, the vane will automatically shift down 5° lower than previous setting.
- In “Auto” setting, the vane will automatically shift between upper and lower limit depending on the intake air temperature as Heating Mode, Airflow Direction Auto-Control. However the upper and lower limit will be shifted 5° downward.

• Powerful operation stops when:-

- Powerful operation has operate for 15 minutes.
- Powerful button is pressed again.
- Quiet button is pressed.
- Stopped by OFF/ON operation button.
- Timer OFF activates.
- Operating mode is changed.

### 8.11. Quiet Operation

- The Quiet operation is to provide quiet cooling/heating operation condition compare to normal operation.

**(Cooling and Soft Dry Operation condition)**

- Once the Quiet Mode is set at the remote control, Quiet Mode LED illuminates. The sound level will reduce either around 2 dB(A) for Lo fan speed or 3 dB(A) for Hi/Me fan speed against the present sound level operation.
- Dew formation become severe at Quiet Lo cool, therefore Quiet Lo cool is operated only 1hr 30 min (1hr QLo, 30 min QLo + 80 rpm). After that, it goes back to QLo+160 (However Quiet LED remains on).
- Manual Fan Speed:-
  - RPM control during Lo cool

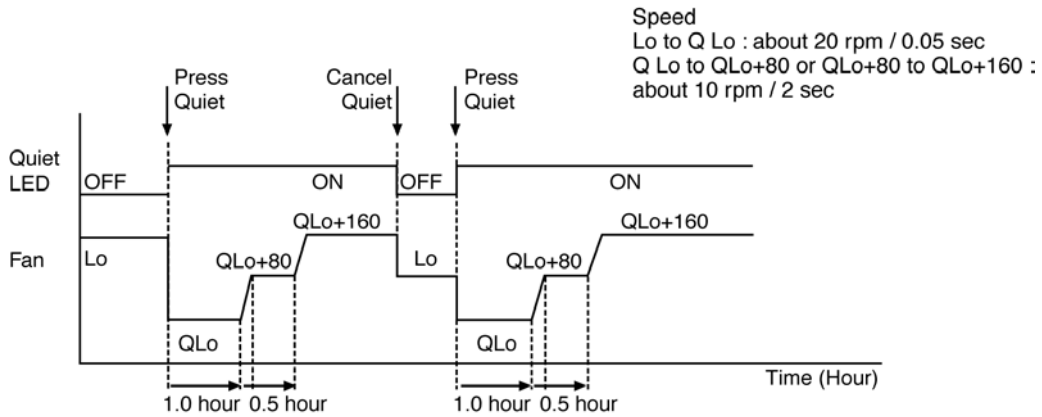

- RPM control during Hi & Me cool

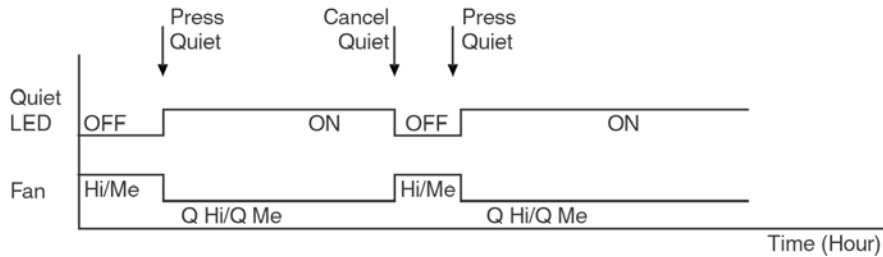

- Auto Fan Speed:-
  - Cooling operation

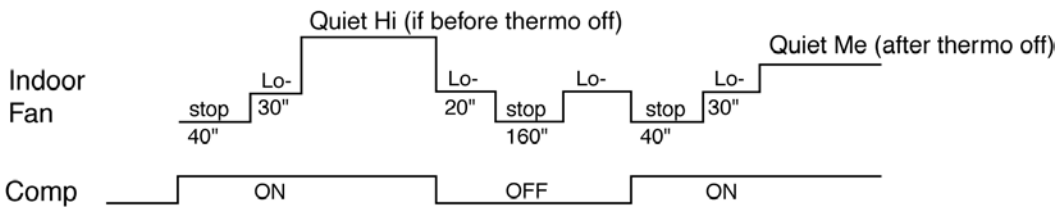

- Soft Dry operation

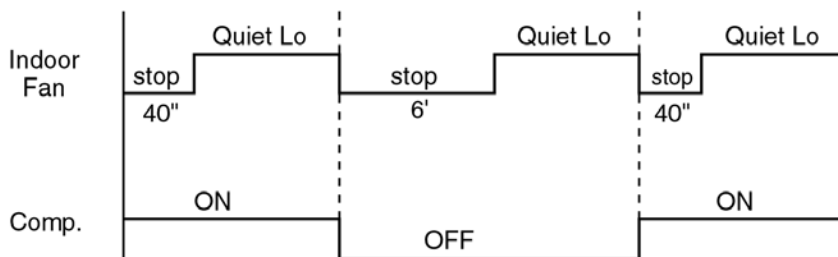

Note: Quiet Lo of Fan speed rpm refer to Indoor Fan Speed Control.

**(Heating Operation condition)**

- When the Quiet Mode is set at the remote control, Quiet Mode LED illuminates. The sound level will reduce either around 2 dB (Lo) or 3 dB (Hi, Me), against the present sound level operation.
- Quiet setting of fan speed rpm refer to Indoor Fan Speed Control.
- Manual Fan Speed:-
  - Rpm control during Lo, Me & Hi Cool

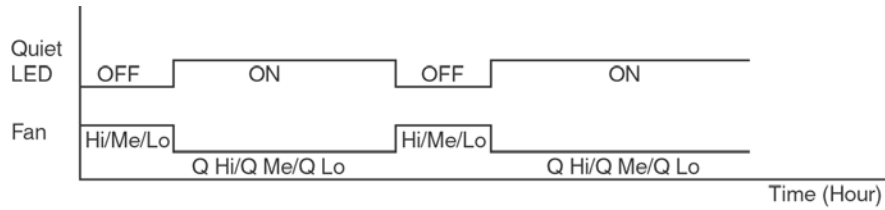

- Auto Fan Speed:-
  - Rpm control depends on the piping air temperature sensor of Indoor heat exchanger

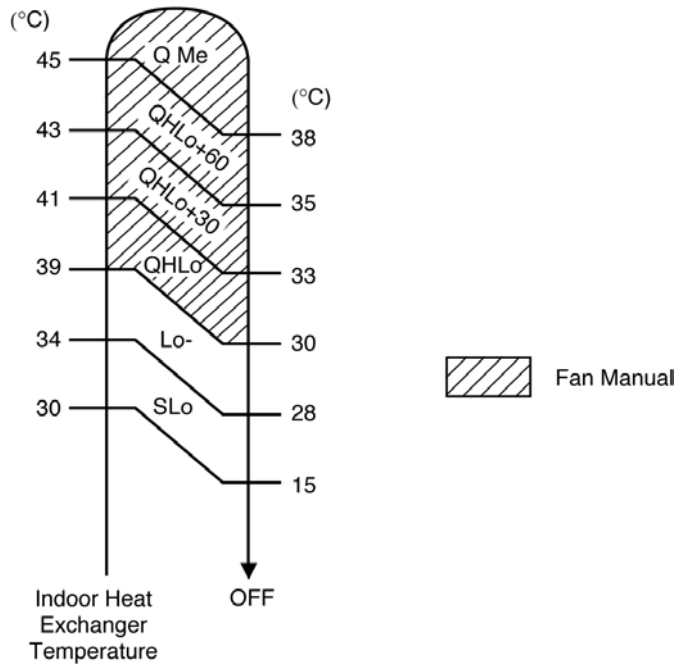

- Quiet operation stops when:-
  - Quiet button is pressed again.
  - Powerful button is pressed.
  - Stopped by OFF/ON operation button.
  - Timer OFF activates.

## 8.12. Ionizer Operation

- The Ionizer operation is to provide fresh air effect to user by producing minus ion in discharge air.

### 8.12.1. Operation Control

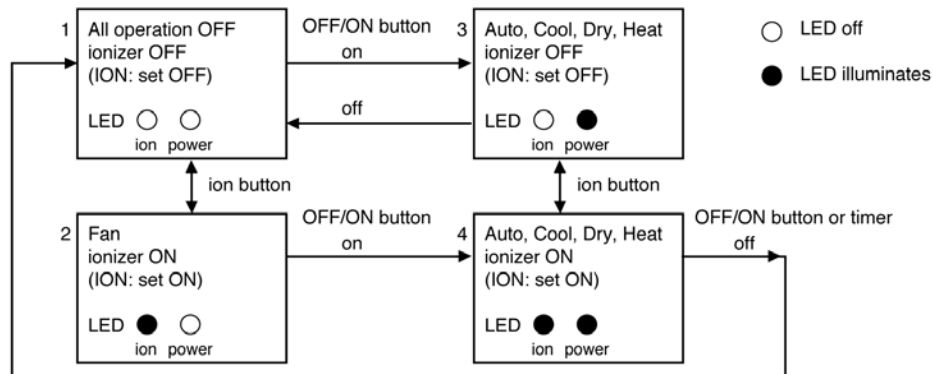

#### 1. Ionizer individual operation

- When air-conditioner unit is at "OFF" condition (standby) and ION operation button at the remote control is pressed, the Ionizer and indoor fan operations will turn on. Only ION LED will illuminate. Power LED maintain off. (1 → 2)
- Ionizer individual operation can be turned off by pressing the ION button again. (2 → 1)
- Fan speed can be adjusted later by customer during this operation.

Indoor fan mode	Fan speed
Manual	Hi, Me, CLo
Auto	between H Lo & C Lo at the pattern shown below

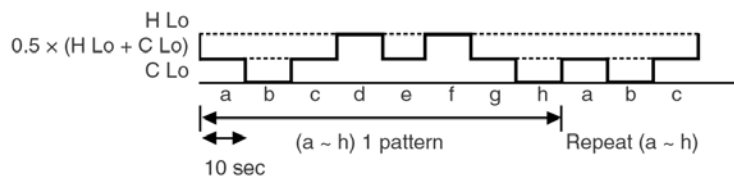

- Vertical airflow direction can be adjusted using remote control during Ionizer individual operation.
- During Ionizer individual operation, operated mode (Auto, Cool, Dry, Heat) can be activated by turning on the OFF/ON operation button. (2 → 4)
- If power failure occur during Ionizer individual operation, after power resume, Ionizer operation will be activated immediately.
- When the Ionizer circuit feedback process error occur for 24 times (about 11hr 30 min.), Ionizer and Air Circulation operations will turn off with ION LED blinks continuously.  
(For details, please refer to Ionizer Error detection control)

#### 2. Operation mode & Ionizer operation.

- When air-conditioner unit is at "ON" condition and ION operation button at the remote control is pressed, the Ionizer operation will turn on. ION & Power LED will illuminate. (3 → 4)
- Ionizer operation stops when:
  - ION operation button is press again.
  - Stopped by OFF/ON operation button.
  - Timer OFF activates.
  - Ionizer circuit feedback signal shows error.
- Ionizer operation status is not memorized when the air conditioner has been switched off. The air-conditioner will operate without ionizer operation when it is turned on again. However, if power failure occurs during Ionizer operation together with Cooling operation, air-conditioner will start to operate at Cooling operation with Ionizer operation when the power is resumed.

### 8.12.2. Error Detection Control

- The error detection control is to inform user that error occurs at ionizer system and repairing job will be needed.
- There are two types of error detection control:
  - a. When Ionizer is ON
    - If ionizer feedback = Lo for 24 times within 11hr 30min, ION LED blinks continuously.
  - b. When ionizer is OFF
    - If ionizer feedback = Hi, ION LED blinks continuously.
- During ionizer at breakdown condition, if ionizer feedback voltage = Lo (become normal), ION LED will stop blinking.
- The error detection control can be reset by:
  - i) Pressing the OFF/ON operation button to switch the operation OFF.
  - ii) Pressing the Auto Operation button to force the operation OFF.
  - iii) Setting the OFF Timer to stop the operation (Not applicable when ionizer is OFF).

### 8.13. Timer Control

- There are 2 types of timer, ON and OFF timer.
- Both ON and OFF timer can be set by pressing ON or OFF button respectively.
- By pressing ON/OFF operation button, ON Timer or OFF Timer will not be cancelled.
- To cancel the previous timer setting, press CANCEL button.
- To activate the previous timer setting, press SET button once again.
- If main power supply is switched off, the timer setting will be cancelled.

#### 8.13.1. ON Timer

- When ON Timer is set by using the remote control, the unit will start to operate slightly before the set time, so that the room will reach nearly to the set temperature by the set time.
- For Cooling and Soft Dry operation, the operation will start 15 minutes before the set time.
- For Heating operation, the operation will start 30 minutes before the set time.
- For Automatic operation, the indoor fan will operate at SLo speed for 25 seconds, 30 minutes before the set time to detect the intake air temperature to determine the operation mode. The operation indication lamp will blink at this time.

#### 8.13.2. OFF Timer

- When OFF Timer is set by using the remote control, the unit will stop operate according to the desired setting.

### 8.14. Random Auto Restart Control

- If there is a power failure during operation, the air conditioner will automatically restart after 3 to 4 minutes when the power is resumed.
- It will start with previous operation mode and airflow direction.
- If there are more than one air conditioner unit in operation and power failure occur, restart time for each unit to operate will be decided randomly using 4 parameters:- intake air temperature, setting temperature, fan speed and air swing louver position.
- This Random Auto Restart Control is not available when Timer is set.
- This control can be omitted by open the circuit of JX2. (Refer Circuit Diagram)

### 8.15. Remote Control Signal Receiving Sound

- Long beep sound will be heard when:-
  - Stopping the air conditioner using OFF/ON operation button.
  - Stopping the Quiet Mode.
  - Stopping the Powerful Mode.
  - Stopping the Ion Mode.
- Short beep sound will be heard for others setting.

# 9 Operating Instructions

## ■ Definition

To prevent personal injury, injury to others and property damage, the following instructions must be followed.

Incorrect operation due to failure to follow instructions will cause harm or damage, the seriousness of which is classified as below:



This sign warns of death or serious injury.



This sign warns of injury or damage to property.

The instructions to be followed are classified by the following symbols:



This symbol denotes an action that is PROHIBITED.



These symbols denote actions that are COMPULSORY.

Thank you for purchasing Panasonic Air Conditioner

## SAFETY PRECAUTIONS

### Installation Precautions



Do not install, remove and reinstall the unit by yourself.

- Improper installation will cause leakage, electric shock or fire. Please consult an authorized dealer or specialist for the installation work.

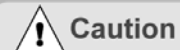

- This air conditioner must be earthed. Improper grounding will cause electric shock.
- Ensure that the drainage piping is connected properly. Otherwise, water will leak.
- Current leakage protection equipment must be installed. Otherwise, electric shock or fire may occur.



- Do not install the unit in a potentially explosive atmosphere.

### Operation Precautions



- Do not share power outlet.
- Do not modify power cord.
- Do not use an extension cord.
- Do not operate with wet hands.
- Do not operate or stop the unit by inserting or pulling out the power plug.
- Do not insert finger or other objects into the indoor or outdoor unit.
- Do not attempt to repair the unit by yourself.
- Do not use rechargeable (Ni-Cd) batteries.
- Keep the remote control away from infants and small children to prevent them from accidentally swallowing the batteries.



- Insert the power plug properly.
- Use specified supply cord.
- If the supply cord is damaged or needed to be replaced, it must be replaced by the manufacturer or its service agent or a similarly qualified person in order to avoid a hazard.
- Remove the batteries if the unit is not going to be used for a long period of time.
- New batteries of the same type must be inserted following the polarity stated to prevent malfunction of the remote control.



- In case of emergency or abnormal condition (burnt, smell, etc) occurs, turn off the power supply and unplug.



- Do not pull the cord to disconnect the plug.
- Do not wash the unit with water, benzene, thinner or scouring powder.
- Do not use for other purposes such as preservation of food.
- Do not use any combustible equipment at airflow direction.
- Do not sit or place anything on the indoor or outdoor unit.
- Do not expose directly to cold air for a long period.



- Ventilate the room regularly.
- Pay attention as to whether the installation rack is damaged after long period of usage.



- Switch off the power supply and unplug before cleaning or servicing.



- Turn off the power supply and unplug if the unit is not used for a long period of time.

### Safety Regulation

The appliance is not intended for use by young children or infirm person without supervision. Young children should be supervised to ensure that they do not play with the appliance.

Replacement or installation of power plugs shall be performed by authorized/qualified personnel only. The wires in this mains lead are coloured in accordance with the following code:

Terminals	wires	colours (GB Standard)
L	red	live
N	black	neutral
E	green/yellow	earth
		brown
		blue
		green- yellow

Different countries may have different colour coding for the wires.

### Operation Condition (°C)

Use this air conditioner under the following temperature range.

DBT: Dry Bulb Temperature WBT: Wet Bulb Temperature	Indoor		Outdoor	
	DBT	WBT	DBT	WBT
Maximum Temperature (COOL)	32	23	43	26
Maximum Temperature (HEAT)	30	-	24	18
Minimum Temperature (COOL)	16	11	16	11
Minimum Temperature (HEAT)	16	-	-5	-6

Note: The illustrations in this manual are for explanation purposes only and may differ from the actual unit. It is subjected to change without notice for future improvement.

# PRODUCT OVERVIEW

## Indoor Unit

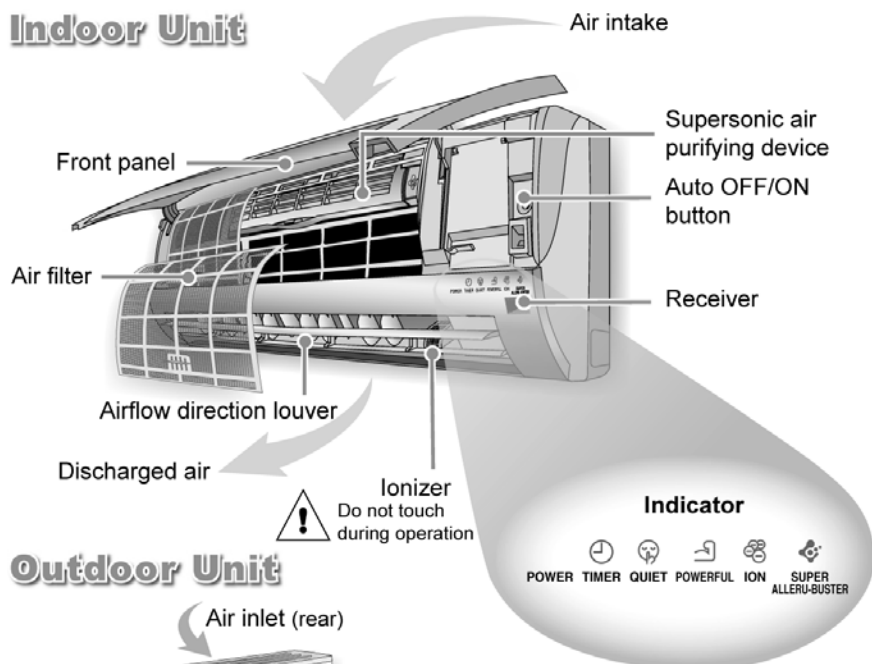

## Outdoor Unit

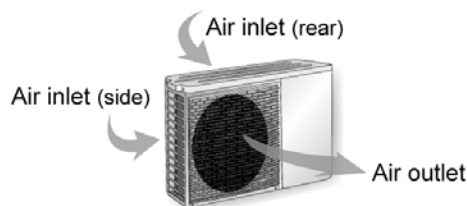

## Remote Control

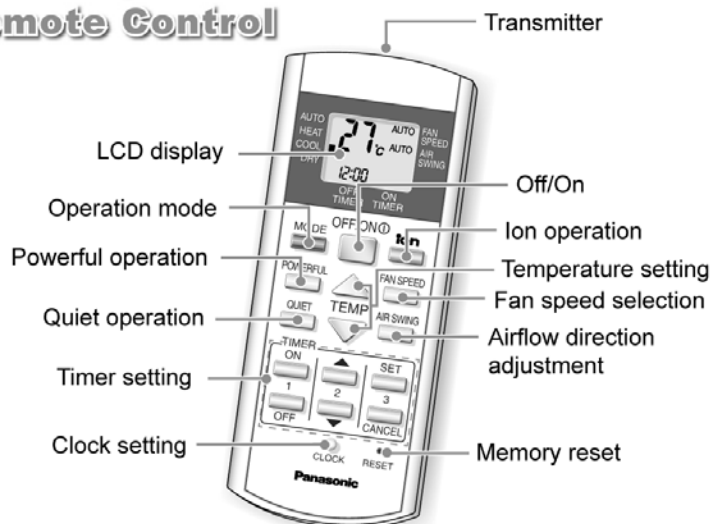

## About

### Remote Control Preparation

1. Pull out
  2. Insert batteries (AAA or R03)
  3. Press CLOCK button
  4. Set current time
  5. Press again to confirm
- Timer operation will be based on current time set.
  - The batteries can be used for approximately 1 year.
  - The batteries must be recycled or disposed of properly.

### Remote Control Signal

- Make sure it is not obstructed.
- Maximum distances : 10m.
- Certain fluorescent lights may interfere with signal transmission. Consult your dealer.

### Auto OFF/ON Button

- To operate the unit if the remote control is misplaced or malfunctioning.

Action	Operation mode
Press once	Automatic Operation
Press until "beep" sound	Cooling Operation

- To OFF, press again the Auto OFF/ON button.
- To switch the remote control signal receiving sound off or on.
  1. Press until "beep" sound and release.
  2. Press again until "beep-beep" sound and release.
  3. Press to switch the sound off or on. (Long "beep"- OFF; short "beep" - ON)

## Troubleshooting

- |  |   |
|--|---|
| ● Operation delayed for few minutes after restart. | ➤ This is a normal self protection control.   |
| ● Sound like water flowing during operation.       | ➤ Caused by refrigerant flow inside.  |
| ● Mist emerges from indoor unit.                   | ➤ Condensation effect due to cooling process.   |
| ● Noisy during operations.                         | ➤ Installation work could be slanted or front panel didn't close properly.                              |
| ● Remote control/display does not work.            | ➤ Check whether batteries are correctly inserted or need replacement.                                   |
| ● The unit cannot operate.                         | ➤ Check either circuit breaker is tripped, power plug is inserted correctly or timer is used correctly. |
| ● Outdoor unit emits water/steam.                  | ➤ Condensation or evaporation happens at piping surface.  |

ENGLISH



# HOW TO OPERATE

## Auto, Heat, Cool, Dry

### ■ Operation Details

#### AUTO - Automatic Operation

- The unit will automatically select the operation mode according to the room temperature.
- Once the operation mode is selected, the unit will operate at the standard setting temperature as shown:

Room temperature	Operation mode	Standard setting temperature
23°C & above	Cool	25°C
Below 23°C	Dry	22°C
Below 20°C	Heat	21°C

- You may press  $\triangle$  or  $\nabla$  button to change the standard setting temperature to "HI" or "LO" as shown:

Operation mode	HI	LO
Cool	27°C	23°C
Dry	24°C	20°C
Heat	23°C	19°C

#### HEAT - Heating Operation

- Enables you to enjoy the warming effect at your preferred setting temperature.
- The range of temperature can be selected from 16°C ~ 30°C.

#### COOL - Cooling Operation

- Enables you to enjoy the cooling effect at your preferred setting temperature.
- The range of temperature can be selected from 16°C ~ 30°C.

#### DRY - Soft Dry Operation

- Enables you to set the desired temperature at low fan speed which provides you with the dehumidifying surroundings.
- The range of temperature can be selected from 16°C ~ 30°C.

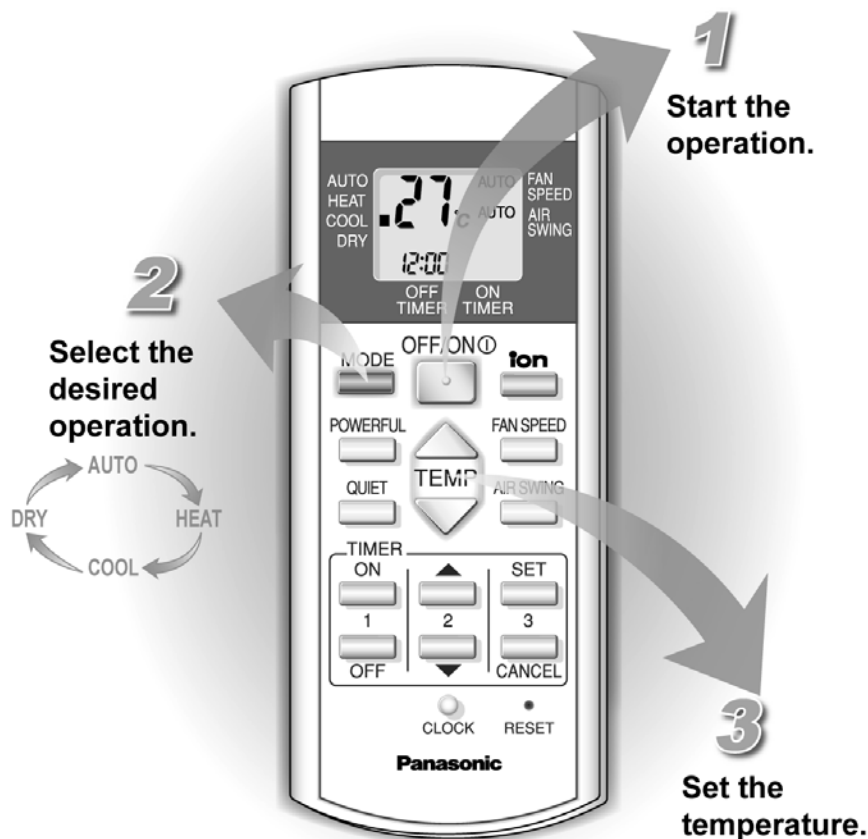

- Supersonic air purifying device (super alleru-buster) operates automatically while the air conditioner is switched on.
- Powerful, Quiet and Ion operations could be activated in all operation modes.
- Press  $\square$  button again to stop the operation.



#### Hint

- To save electricity, close the curtains when using air conditioner to prevent sunlight and heat from coming in.



#### Troubleshooting

- The room has a peculiar odour.
  - This may be a damp smell emitted by the wall, carpet, furniture or clothing in the room.
- Air conditioner does not cool or heat efficiently.
  - Ensure the temperature has been set correctly.
  - Ensure windows and doors have been closed properly.
  - Ensure filters are cleaned or replaced when necessary.
  - Ensure inlet and outlet vents of the units have not been obstructed.
- In heating operation, power indicator blinking and no warm air discharge.
  - Defrost operation at outdoor unit, maximum 12 minutes.

# HOW TO OPERATE

## Powerful, Quiet, Ion, Fan Speed, Air Swing

### POWERFUL

Enables powerful operation.

### ION

Enables ion operation.

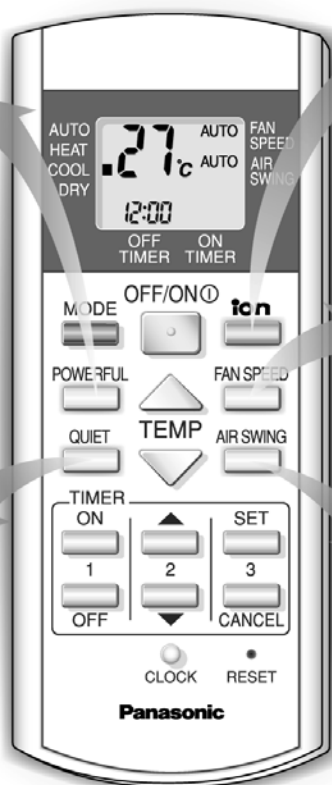

### FAN SPEED

Select fan speed.



### AIR SWING

Adjust the vertical airflow direction louver.



### QUIET

Enables quiet operation.

### Operations Details

#### POWERFUL

- To achieve setting temperature quickly. It will operate for 15 minutes and return to the previous setting.

#### QUIET

- To provide a quiet environment.

#### ION

- To provide fresh air effect by producing negative ions.

#### FAN SPEED

- To provide you with the various fan speed selections.
- There are 3 levels of fan speed in addition to automatic fan speed.
- Automatic fan speed: The speed of the indoor fan is automatically adjusted according to the operation.

#### AIR SWING

- To ventilate air in the room.
- There are 5 selections in addition to automatic vertical air flow direction.
- If automatic vertical airflow direction has been set, the louver swings up and down automatically.
- Please do not adjust the vertical airflow direction louver manually.
- Horizontal airflow direction louver could be adjusted manually.

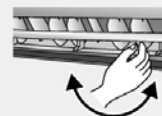

- Ion operation could be activated independently.
- Powerful and Quiet operations could not be activated at the same time.
- Powerful, Quiet and Ion operations could be cancelled by pressing the respective button again.

#### Hints



- If you wish to have the cool air blowing directly on you, set the airflow direction downward but not for an excessive length of time, as it may harm your health.
- Approximately 10% of electricity can be saved if you set the temperature 1°C higher in cooling operation or 2°C lower in heating operation than the desired temperature.

#### Troubleshooting



- ION indicator on the indoor unit is blinking.
  - Press ION button twice. If the indicator is still blinking, please consult the dealer.
- Indoor fan stops occasionally during Automatic Fan Speed setting.
  - This is an advanced feature that helps to remove smell from the surrounding area during operation.
- Indoor fan stops occasionally during heating operation.
  - To avoid unintended cooling effect.

## ■ Operation Details



### TIMER

- Use the ON timer to turn on the air conditioner at the desired time. This will give you a cooling or warming environment, e.g. when you return from work or wake up.
- When the ON timer is set, operation will start 15 minutes for COOL/DRY or 30 minutes for AUTO/HEAT before the actual set time.
- Use the OFF timer to stop the air conditioner operation at the desired time. This can save electricity while you are going out or sleeping.
- The set timer will repeat daily once it is set.
- If there is a power failure, you can press SET button to restore the previous setting once the power is resumed.
- If the timer is cancelled, you can restore the previous setting by pressing SET button.

# HOW TO OPERATE

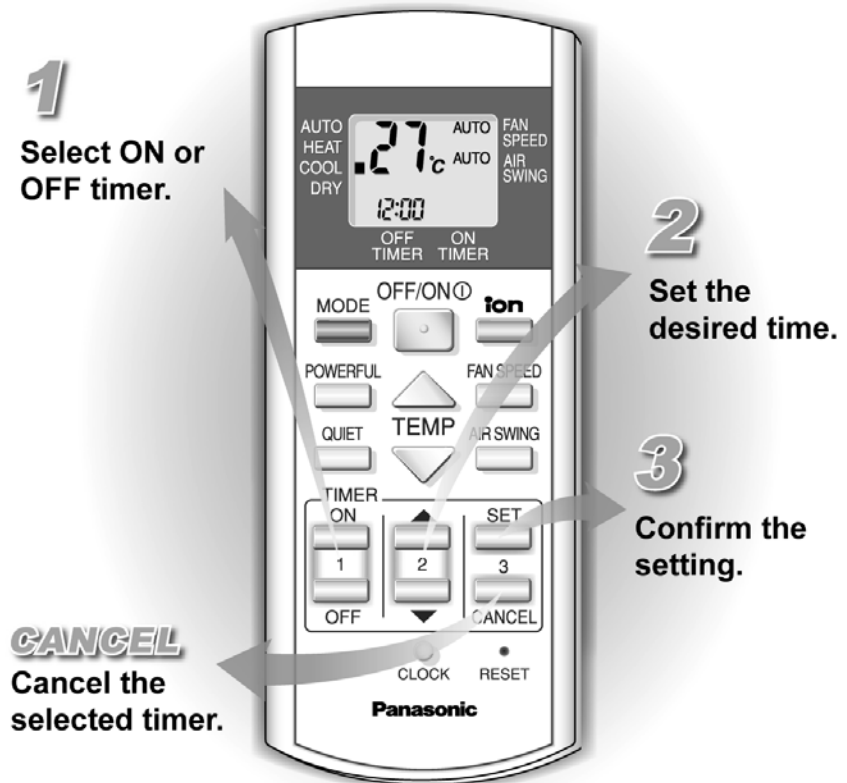
## Timer



- Ensure the clock on the remote control has been set correctly.
- You could use the ON and OFF timers at the same time.
- To cancel either the ON or OFF timer, press  or , then press .



### Hints

- Press CLOCK more than 10 seconds to change the time format from 24 hours to AM/PM format.
- For your convenience, you could set the air conditioner to operate automatically by using both ON and OFF timer.



### Troubleshooting

- TIMER indicator always on.
  - Timer is activated and the setting will repeat itself daily.
- POWER indicator is blinking 30 minutes before ON timer is activated.
  - The unit is determining the operation mode by sensing the room temperature. This happens when it has been set to AUTO operation mode.

# CARE & CLEANING



**Switch off the power supply before cleaning**

## FRONT PANEL

Raise and pull to remove. Wash and dry.

## AIR FILTER

Vacuum, wash and dry.

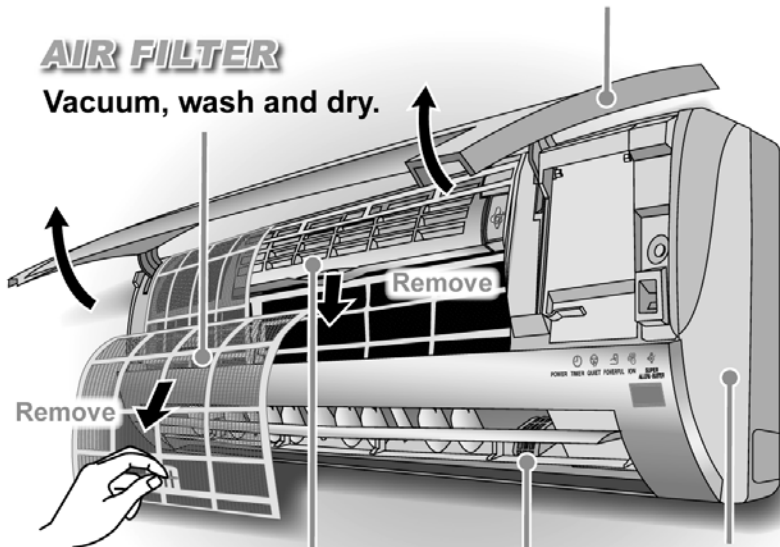

## SUPERSONIC AIR PURIFYING DEVICE

Vacuum the super alleru-buster filter.

## INDOOR UNIT

Wipe gently.

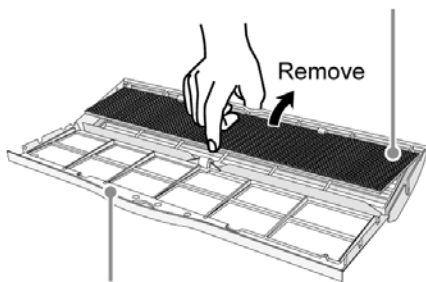

Vacuum, wash and dry the frame.

## IONIZER

Clean with cotton bud.

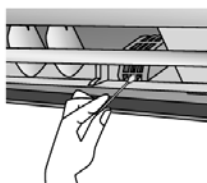

### Washing Instructions

- Do not use benzene, thinner or scouring powder.
- Use soaps or neutral household detergent (pH7) only.
- Do not use water with temperature higher than 40°C.

### INDOOR UNIT

- Wipe the unit gently with a soft, dry cloth.

### AIR FILTER

- It is recommended to clean the air filters once every 2 weeks.
- Purchase the replacement filter if it is damaged.

Part no.: CWD001144

### SUPER ALLERU-BUSTER

- It is recommended to clean the filter every 6 months.
- Replace the filter every 3 years or purchase the replacement filter if it is damaged.

Part no.: CZ-SA13P

### IONIZER

- It is recommended to clean the ionizer every 6 months.

### Preparation for extended Non-operation

- Operate the unit for 2~3 hours using heating operation to dry the internal parts.
- Turn off the power supply and unplug.
- Remove the remote control batteries.

### Pre-season Inspection

- This inspection is recommended before operating the air conditioner at every season.
- Check if the remote control batteries needed to be replaced.
- Ensure there is no obstruction at all air intake and outlet vents.
- After the start of operation for 15 minutes, it is normal if the temperature differences between air intake and outlet vents at indoor unit is:-

Operation	Temperature
Cooling	≥ 8°C
Heating	≥ 14°C

### Hints



- Clean the filter regularly as dirty filters will cause unpurified air, low cooling or heating capacity, unpleasant smells and higher energy consumption.
- The unit will become dirty and the performance of the unit will decrease after used for several seasons. Please consult an authorized dealer to perform seasonal inspections in addition to regular cleaning.
- This air conditioner is equipped with a built-in surge protective device. However, in order to further protect your air conditioner from being damaged by abnormally strong lightning activity, you may switch off the power supply.

# 10 Installation Instructions

Required tools for Installation Works			
1. Philips screw driver	5. Spanner	9. Gas leak detector	13. Multimeter
2. Level gauge	6. Pipe cutter	10. Measuring tape	14. Torque wrench 18 N.m (1.8 kgf.m) 42 N.m (4.2 kgf.m) 55 N.m (5.5 kgf.m)
3. Electric drill, hole core drill (ø70 mm)	7. Reamer	11. Thermometer	15. Vacuum pump
4. Hexagonal wrench (4 mm)	8. Knife	12. Megameter	16. Gauge manifold

## 10.1. Safety Precautions

- Read the following “SAFETY PRECAUTIONS” carefully before installation.
- Electrical work must be installed by a licensed electrician. Be sure to use the correct rating of the power plug and main circuit for the model to be installed.
- The caution items stated here must be followed because these important contents are related to safety. The meaning of each indication used is as below. Incorrect installation due to ignoring of the instruction will cause harm or damage, and the seriousness is classified by the following indications.



 <b>WARNING</b>	This indication shows the possibility of causing death or serious injury.
--	---

 <b>CAUTION</b>	This indication shows the possibility of causing injury or damage to properties only.
--	---

The items to be followed are classified by the symbols:

	Symbol with background white denotes item that is PROHIBITED from doing.
---	--

- Carry out test running to confirm that no abnormality occurs after the installation. Then, explain to user the operation, care and maintenance as stated in instructions. Please remind the customer to keep the operating instructions for future reference.

 <b>WARNING</b>	
1. Engage dealer or specialist for installation. If installation done by the user is defective, it will cause water leakage, electrical shock or fire.	
2. Install according to this installation instruction strictly. If installation is defective, it will cause water leakage, electrical shock or fire.	
3. Use the attached accessories parts and specified parts for installation. Otherwise, it will cause the set to fall, water leakage, fire or electrical shock.	
4. Install at a strong and firm location which is able to withstand the set's weight. If the strength is not enough or installation is not properly done, the set will drop and cause injury.	
5. For electrical work, follow the local national wiring standard, regulation and this installation instruction. An independent circuit and single outlet must be used. If electrical circuit capacity is not enough or defect found in electrical work, it will cause electrical shock or fire.	
6. Use the specified cable (1.5 mm <sup>2</sup> ) and connect tightly for indoor/outdoor connection. Connect tightly and clamp the cable so that no external force will be acted on the terminal. If connection or fixing is not perfect, it will cause heat-up or fire at the connection.	
7. Wire routing must be properly arranged so that control board cover is fixed properly. If control board cover is not fixed perfectly, it will cause heat-up at connection point of terminal, fire or electrical shock.	
8. When carrying out piping connection, take care not to let air substances other than the specified refrigerant go into refrigeration cycle. Otherwise, it will cause lower capacity, abnormal high pressure in the refrigeration cycle, explosion and injury.	
9. Do not damage or use unspecified power supply cord. Otherwise, it will cause fire or electrical shock.	
10. Do not modify the length of the power supply cord or use of the extension cord, and do not share the single outlet with other electrical appliances. Otherwise, it will cause fire or electrical shock.	







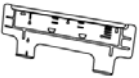

 **CAUTION**

1. The equipment must be earthed. It may cause electrical shock if grounding is not perfect.
2. Do not install the unit at place where leakage of flammable gas may occur. In case gas leaks and accumulates at surrounding of the unit, it may cause fire. 
3. Carry out drainage piping as mentioned in installation instructions. If drainage is not perfect, water may enter the room and damage the furniture.

**ATTENTION**

1. Selection of the installation location.  
Select a installation location which is rigid and strong enough to support or hold the unit, and select a location for easy maintenance.
2. Power supply connection to the room air conditioner.  
Connect the power supply cord of the room air conditioner to the mains using one of the following method.  
Power supply point shall be the place where there is ease for access for the power disconnection in case of emergency.  
In some countries, permanent connection of this room air conditioner to the power supply is prohibited.
  1. Power supply connection to the receptacle using a power plug.  
Use an approved 15A/16A power plug with earth pin for the connection to the socket.
  2. Power supply connection to a circuit breaker for the permanent connection. Use an approved 16A circuit breaker for the permanent connection. It must be a double pole switch with a minimum 3 mm contact gap.
3. Do not release refrigerant.  
Do not release refrigerant during piping work for installation, reinstallation and during repairing a refrigeration parts. Take care of the liquid refrigerant, it may cause frostbite.
4. Installation work.  
It may need two people to carry out the installation work.
5. Do not install this appliance in a laundry room or other location where water may drip from the ceiling, etc.

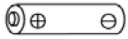
## 10.2. Attached accessories

No.	Accessories part	Qty.	No.	Accessories part	Qty.
1	Installation plate 	1	5	Remote control holder 	1
2	Installation plate fixing screw 	6	6	Remote control holder fixing screw 	2
3	Remote control 	1	7	Super alleru-buster filter 	1
4	Battery 	2	8	Drain elbow (Only for models: A7DK, A9DK, A12DK) 	1

Applicable piping kit

CZ-3F5, 7AEN (C7DK, C9DK, A7DK, A9DK, )

CZ-4F5,7, 10AN (C12DK, A12DK)

## 10.3. Select the best location

### INDOOR UNIT

- There should not be any heat source or steam near the unit.
- There should not be any obstacles blocking the air circulation.
- A place where air circulation in the room is good.
- A place where drainage can be easily done.
- A place where noise prevention is taken into consideration.
- Do not install the unit near the door way.
- Ensure the spaces indicated by arrows from the wall, ceiling, fence or other obstacles.
- Recommended installation height for indoor unit shall be at least 2.3 m.

### OUTDOOR UNIT

- If an awning is built over the unit to prevent direct sunlight or rain, be careful that heat radiation from the condenser is not obstructed.
- There should not be any animal or plant which could be affected by hot air discharged.
- Keep the spaces indicated by arrows from wall, ceiling, fence or other obstacles.
- Do not place any obstacles which may cause a short circuit of the discharged air.
- If piping length is over the common length, additional refrigerant should be added as shown in the table.

Model	Piping size		Rated Length (m)	Max. Elevation (m)	Max. Piping Length (m)	Additional Refrigerant (g/m)
	Gas	Liquid				
C7DK/C9DK	3/8"	1/4"	7.5	5	10	10
A7DK/A9DK	3/8"	1/4"	7.5	5	10	20
C12DK	1/2"	1/4"	7.5	5	15	10
A12DK	1/2"	1/4"	7.5	5	15	20

## 10.4. Indoor/Outdoor Unit Installation Diagram

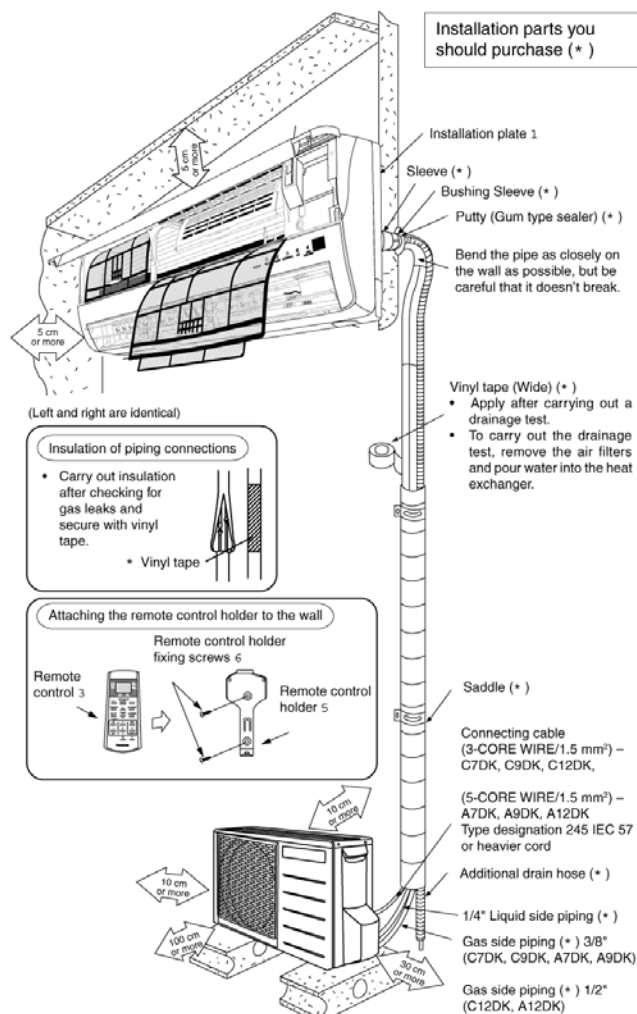

- This illustration is for explanation purposes only. The indoor unit will actually face a different way.

- This illustration is for explanation purposes only. The indoor unit will actually face a different way.

## 10.5. Indoor unit

### 10.5.1. SELECT THE BEST LOCATION (Refer to “Select the best location” section)

### 10.5.2. HOW TO FIX INSTALLATION PLATE

The mounting wall is strong and solid enough to prevent it from the vibration.

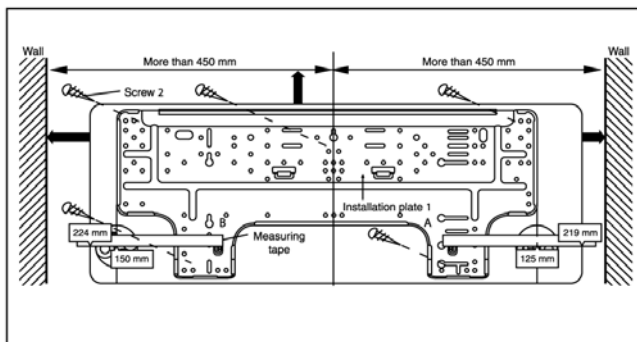

The centre of installation plate should be at more than 450 mm at right and left of the wall.

The distance from installation plate edge to ceiling should more than 67 mm.

From installation plate left edge to unit's left side is 74 mm.

From installation plate right edge to unit's right is 94 mm.

- Ⓑ :
- : For left side piping, piping connection for liquid should be about 15 mm from this line.
  - : For left side piping, piping connection for gas should be about 45 mm from this line.
  - : For left side piping, piping connecting cable should be about 800 mm from this line.

1. Mount the installation plate on the wall with 5 screws or more.

(If mounting the unit on the concrete wall consider using anchor bolts.)

- Always mount the installation plate horizontally by aligning the marking-off line with the thread and using a level gauge.

2. Drill the piping plate hole with  $\phi 70$  mm hole-core drill.

- Line according to the arrows marked on the lower left and right side of the installation plate. The meeting point of the extended line is the centre of the hole. Another method is by putting measuring tape at position as shown in the diagram above. The hole centre is obtained by measuring the distance namely 150 mm and 125 mm for left and right hole respectively.
- Drill the piping hole at either the right or the left and the hole should be slightly slanted to the outdoor side.

### 10.5.3. TO DRILL A HOLE IN THE WALL AND INSTALL A SLEEVE OF PIPING

1. Insert the piping sleeve to the hole.
2. Fix the bushing to the sleeve.
3. Cut the sleeve until it extrudes about 15 mm from the wall.

#### Caution

When the wall is hollow, please be sure to use the sleeve for tube ass'y to prevent dangers caused by mice biting the connecting cable.

4. Finish by sealing the sleeve with putty or caulking compound at the final stage.

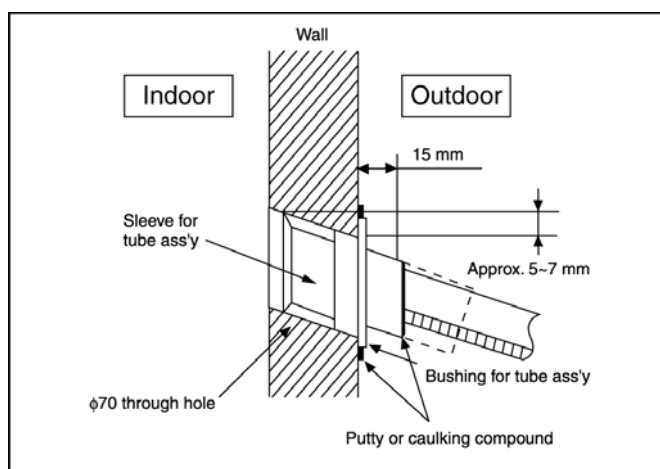

### 10.5.4. INDOOR UNIT INSTALLATION

#### 1. For the right rear piping

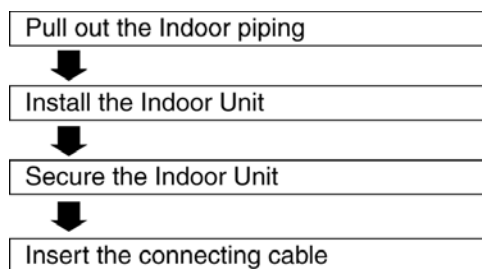

#### 2. For the right and right bottom piping

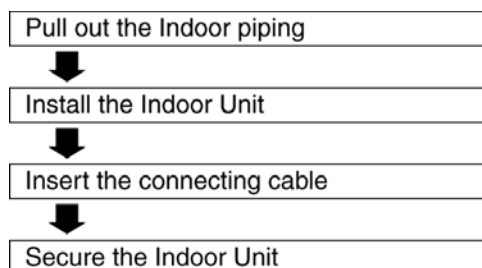



### 3. For the embedded piping

- Replace the drain hose
- ↓
- Bend the embedded piping
  - Use a spring bender or equivalent to bend the piping so that the piping is not crushed.
- ↓
- Install the Indoor Unit
- ↓
- Cut and flare the embedded piping
  - When determining the dimension of the piping, slide the unit all the way to the left on the installation plate.
  - Refer to the section "Cutting and flaring the piping".
- ↓
- Pull the connecting cable into Indoor Unit
  - The inside and outside connecting cable can be connected without removing the front grille.
- ↓
- Connect the piping
  - Please refer to "Connecting the piping" column in outdoor unit section. (Below steps are done after connecting the outdoor piping and gas-leakage confirmation.)
- ↓
- Insulate and finish the piping
  - Please refer to "Piping and finishing" column of outdoor section and "Insulation of piping connections" column as mentioned in Indoor/Outdoor Unit Installation.
- ↓
- Secure the Indoor Unit

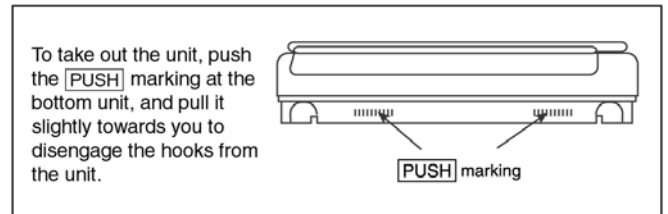
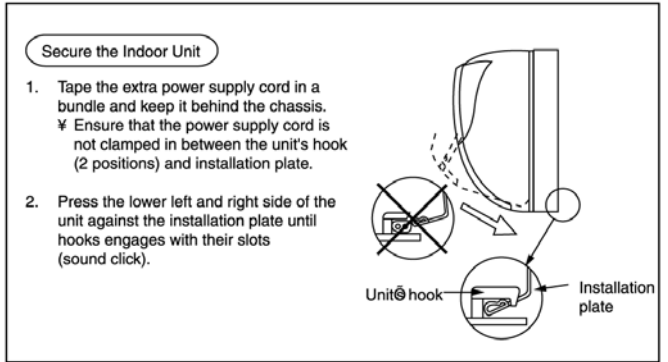
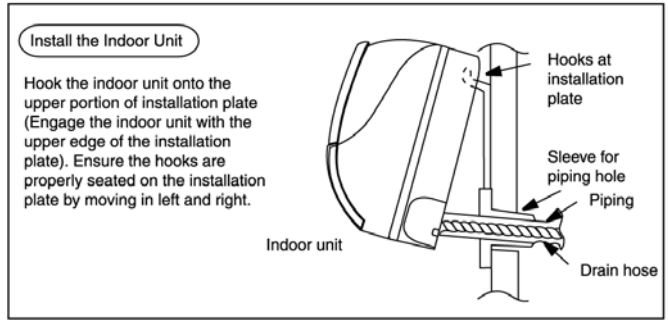

(This can be used for left rear piping & left bottom piping also.)

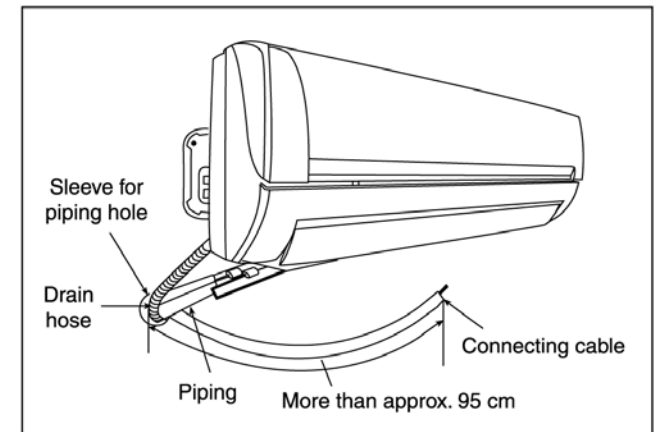
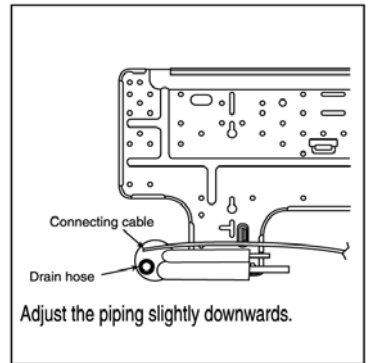
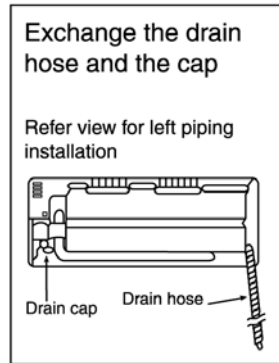
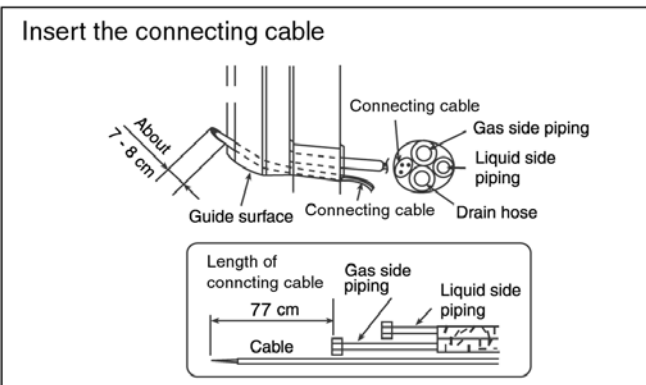
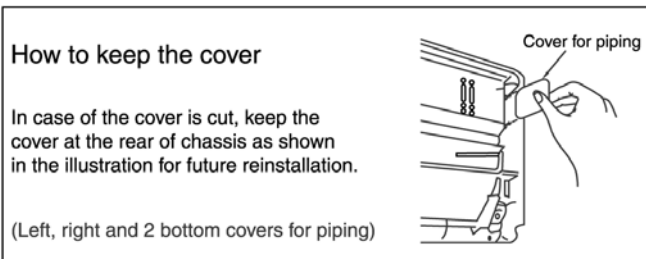
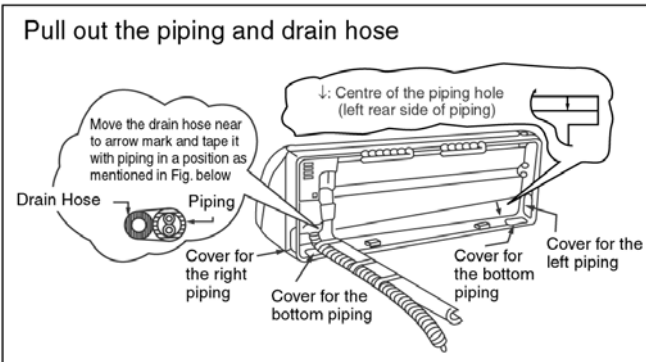

- How to pull the piping and drain hose out, in case of the embedded piping.

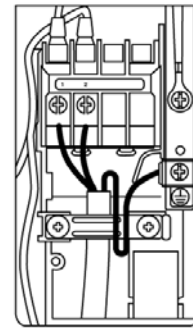
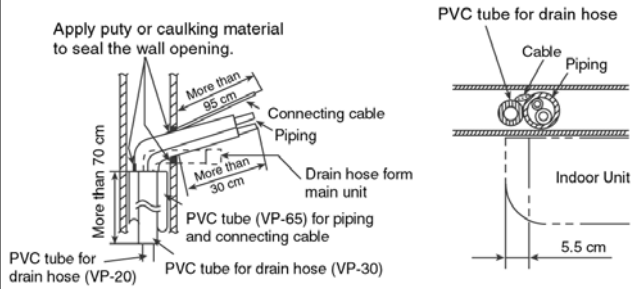

C7DK, C9DK, C12DK

- In case of left piping how to insert the connecting cable and drain hose.

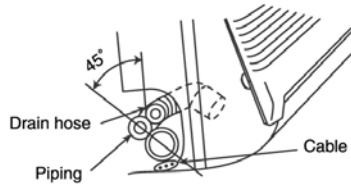

(For the right piping, follow the same procedure)

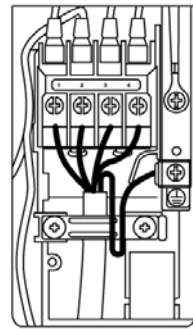

A7DK, A9DK, A12DK

### 10.5.5. CONNECT THE CABLE TO THE INDOOR UNIT

1. The inside and outside connecting cable can be connected without removing the front grille.
2. Connecting cable between indoor unit and outdoor unit shall be approved polychloroprene sheathed 3 (C7DK, C9DK, C12DK) or 5 (A7DK, A9DK, A12DK) × 1.5 mm<sup>2</sup> flexible cord, type designation 245 IEC 57 or heavier cord.
  - Ensure the color of wires of outdoor unit and the terminal Nos. are the same to the indoor's respectively.
  - Earth lead wire shall be longer than the other lead wires as shown in the figure for the electrical safety in case of the slipping out of the cord from the anchorage.

C7DK, C9DK, C12DK

Terminals on the indoor unit	1	2	
Color of wires			
Terminals on the outdoor unit	1	2	

A7DK, A9DK, A12DK

Terminals on the indoor unit	1	2	3	4	
Color of wires					
Terminals on the outdoor unit	1	2	3	4	

- Secure the cable onto the control board with the holder (clammer).

### INSTALLATION OF SUPER ALLERU-BUSTER FILTER

1. Open the front panel.
2. Remove the air filters.
3. Remove Supersonic air purifying device.
4. Open the Supersonic air purifying device frame.
5. Insert the super alleru-buster filter and close the Supersonic air purifying device frame as shown in illustration at below.

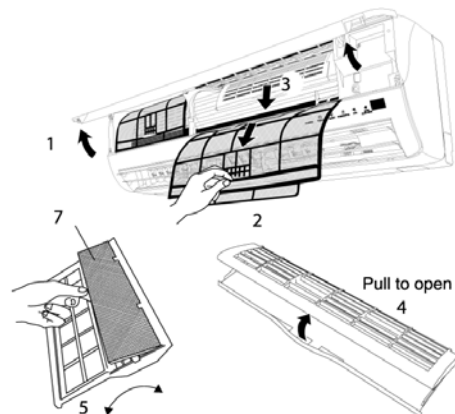

### HOW TO TAKE OUT FRONT GRILLE

Please follow the steps below to take out front grille if necessary such as when servicing.

1. Open the intake grille and remove the screw at the front of the front grille.

2. Set the vertical airflow direction louver to the horizontal position.
3. Slide down the 2 caps on the front grille as shown in the illustration at right, and then remove the 2 mounting screws.
4. Pull the lower section of the front grille towards you to remove the front grille.

When reinstalling the front grille, first set the vertical airflow direction louver to the horizontal position and then carry out above steps 2 - 3 in the reverse order.

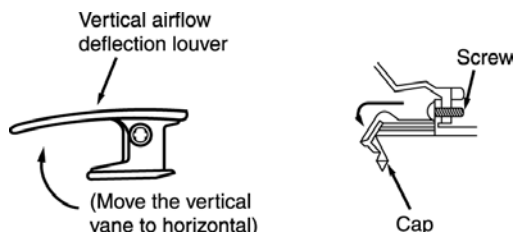

### AUTO SWITCH OPERATION

The below operations will be performed by pressing the "AUTO" switch.

#### 1. AUTO OPERATION MODE

The Auto operation will be activated immediately once the Auto Switch is pressed.

#### 2. TEST RUN OPERATION (FOR PUMP DOWN/SERVICING PURPOSE)

The Test Run operation will be activated if the Auto Switch is pressed continuously for more than 5 sec. to below 10 sec. A "pep" sound will occur at the fifth sec., in order to identify the starting of Test Run operation

#### 3. REMOTE CONTROLLER RECEIVING SOUND ON/OFF

The ON/OFF of Remote Controller receiving sound can be change over by the following steps:

a) Release the Auto Switch after Test Run operation is activated.

b) Then, within 20 sec. after (a), press Auto Switch for more than 5 sec..A "beep" "beep" sound will occur at the fifth sec., then release the Auto Switch.

c) Within 20 sec. after (b), press Auto Switch again. Everytime Auto Switch is pressed (within 20 sec. interval), remote controller receiving sound status will be reversed between ON and OFF.

Long "beep" sound indicates that remote controller receiving sound is OFF.

Short "beep" sound indicates that remote controller receiving sound is ON.

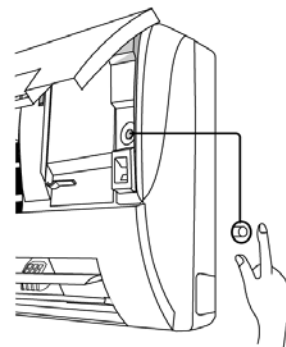

## 10.6. Outdoor unit

### 10.6.1. SELECT THE BEST LOCATION (Refer to "Select the best location" section)

### 10.6.2. INSTALL THE OUTDOOR UNIT

- After selecting the best location, start installation according to Indoor/Outdoor Unit Installation Diagram.

1. Fix the unit on concrete or rigid frame firmly and horizontally by bolt nut. (ø10 mm).
2. When installing at roof, please consider strong wind and earthquake. Please fasten the installation stand firmly with bolt or nails.

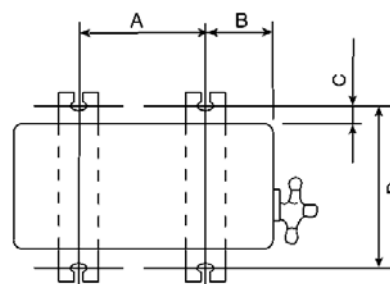

Model	A	B	C	D
C7DK, C9DK, A7DK, A9DK	474	87	18.5	261
C12DK, A12DK	570	105	18.5	320

### 10.6.3. CONNECTING THE PIPING

#### Connecting The Piping To Indoor Unit

Please make flare after inserting flare nut (locate at joint portion of tube assembly) onto the copper pipe. (In case of using long piping)

Connect the piping

- Align the center of piping and sufficiently tighten the flare nut with fingers.
- Further tighten the flare nut with torque wrench in specified torque as stated in the table.

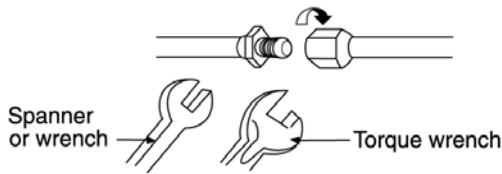

MODEL	Piping size (Torque)	
	Gas	Liquid
C7DK, C9DK, A7DK, A9DK	3/8" (42 N.m)	1/4" (18 N.m)
C12DK, A12DK	1/2" (55 N.m)	1/4" (18 N.m)

**Connecting The Piping To Outdoor Unit**

Decide piping length and then cut by using pipe cutter. Remove burrs from cut edge. Make flare after inserting the flare nut (located at valve) onto the copper pipe.

Align center of piping to valves and then tighten with torque wrench to the specified torque as stated in the table.

**CUTTING AND FLARING THE PIPING**

1. Please cut using pipe cutter and then remove the burrs.
2. Remove the burrs by using reamer. If burrs is not removed, gas leakage may be caused.  
Turn the piping end down to avoid the metal powder entering the pipe.
3. Please make flare after inserting the flare nut onto the copper pipes.

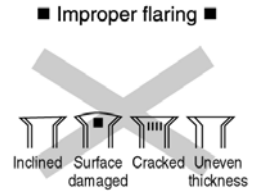
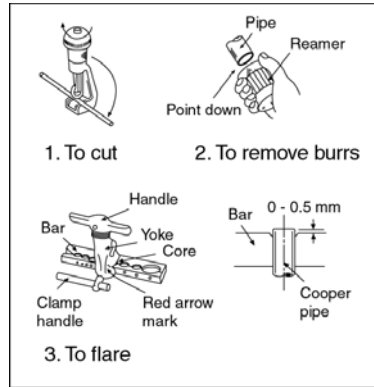

When properly flared, the internal surface of the flare will evenly shine and be of even thickness. Since the flare part comes into contact with the connections, carefully check the flare finish.

## 10.6.4. EVACUATION OF THE EQUIPMENT

WHEN INSTALLING AN AIR CONDITIONER, BE SURE TO EVACUATE THE AIR INSIDE THE INDOOR UNIT AND PIPES in the following procedure.

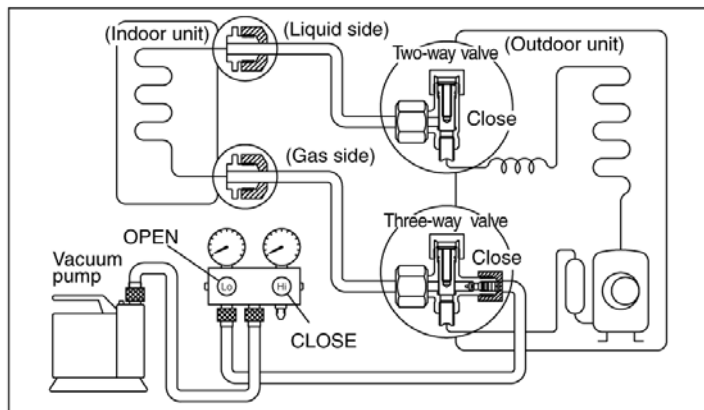

1. Connect a charging hose with a push pin to the Low and High side of a charging set and the service port of the 3-way valve.
  - Be sure to connect the end of the charging hose with the push pin to the service port.
2. Connect the center hose of the charging set to a vacuum pump.
3. Turn on the power switch of the vacuum pump and make sure that the needle in the gauge moves from 0 cmHg (0 MPa) to -76 cmHg (-0.1 MPa). Then evacuate the air approximately ten minutes.
4. Close the low side valve of the charging set and turn off the vacuum pump. Make sure that the needle in the gauge does not move after approximately five minutes.
 

Note: BE SURE TO FOLLOW THIS PROCEDURE IN ORDER TO AVOID REFRIGERANT GAS LEAKAGE.
5. Disconnect the charging hose from the vacuum pump and from the service port of the 3-way valve.
6. Tighten the service port caps of the 3-way valve at torque of 18 N.m with a torque wrench.
7. Remove the valve caps of both of the 2-way valve and 3-way valve. Position both of the valves to "OPEN" using a hexagonal wrench (4 mm).
8. Mount valve caps onto the 2-way valve and the 3-way valve.
  - Be sure to check for gas leakage.

### CAUTION

- If gauge needle does not move from 0 cmHg (0 MPa) to -76 cmHg (-0.1 MPa), in step 3 above take the following measure:
- If the leak stops when the piping connections are tightened further, continue working from step 3.
- If the leak does not stop when the connections are retightened, repair the location of leak.
- Do not release refrigerant during piping work for installation and reinstallation. Take care of the liquid refrigerant, it may cause frostbite.

## 10.6.5. CONNECT THE CABLE TO THE OUTDOOR UNIT

1. Remove the control board cover from the unit by loosening the screw.
2. Connecting cable between indoor unit and outdoor unit shall be approved polychloroprene sheathed 3 (C7DK, C9DK, C12DK) or 5 (A7DK, A9DK, A12DK) × 1.5 mm<sup>2</sup> flexible cord, type designation 245 IEC 57 or heavier cord.

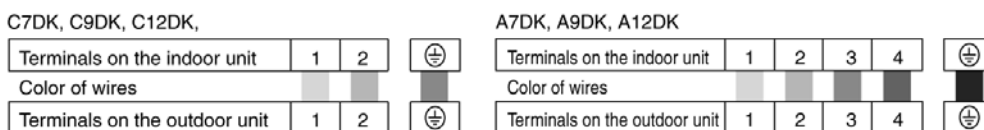

3. Secure the cable onto the control board with the holder (clammer).
4. Attach the control board cover back to the original position with the screw.

## 10.6.6. PIPE INSULATION

1. Please carry out insulation at pipe connection portion as mentioned in Indoor/Outdoor Unit Installation Diagram. Please wrap the insulated piping end to prevent water from going inside the piping.
2. If drain hose or connecting piping is in the room (where dew may form), please increase the insulation by using POLY-E FOAM with thickness 6 mm or above.

### DISPOSAL OF OUTDOOR UNIT DRAIN WATER

- If the drain elbow is used, the unit should be placed on a stand which is taller than 3cm.
- If the unit is used in an area where temperature falls below 0° C for 2 or 3 days in succession, it is recommended not to use a drain elbow, for the drain water freezes and the fan will not rotate.

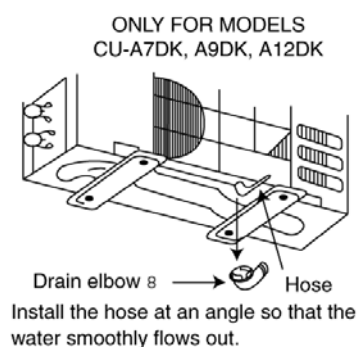

### CHECK THE DRAINAGE

- Open front panel and remove air filters.  
(Drainage checking can be carried out without removing the front grille.)
- Pour a glass of water into the drain tray-styrofoam.
- Ensure that water flows out from drain hose of the indoor unit.

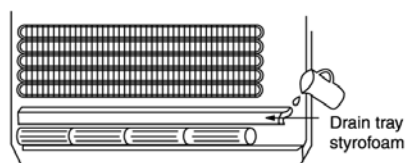

### EVALUATION OF THE PERFORMANCE

- Operate the unit at cooling operation mode for fifteen minutes or more.
- Measure the temperature of the intake and discharge air.
- Ensure the difference between the intake temperature and the discharge is more than 8°C.

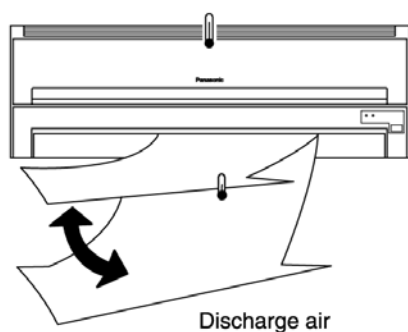

<b>CHECK ITEMS</b>
--------------------

- Is there any gas leakage at flare nut connections?
- Has the heat insulation been carried out at flare nut connection?
- Is the connecting cable being fixed to terminal board firmly?
- Is the connecting cable being clamped firmly?
- Is the drainage OK?  
(Refer to "Check the drainage" section)
- Is the earth wire connection properly done?
- Is the indoor unit properly hooked to the installation plate?
- Is the power supply voltage complied with rated value?
- Is there any abnormal sound?
- Is the cooling operation normal?
- Is the thermostat operation normal?
- Is the remote control's LCD operation normal?
- Is the super alleru-buster filter installed?

# 11 2-way, 3-way Valve

	2-way Valve (Liquid Side)	3-way Valve (Gas Side)	
Works	Shaft Position	Shaft Position	Service Port
Shipping	Close (With valve cap)	Close (With valve cap)	Close (With cap)
Evacuation (Installation and Re-installation)	Close (Counter-Clockwise)	Close (Clockwise)	Open (Push-pin)
Operation	Open (With valve cap)	Open (With valve cap)	Close (With cap)
Pumping down (Transferring)	Close (Clockwise)	Open (Counter-Clockwise)	Open (Connected manifold gauge)
Evacuation (Servicing)	Open	Open	Open With vacuum pump
Gas charging (Servicing)	Open	Open	Open (With charging cylinder)
Pressure check (Servicing)	Open	Open	Open (Connected manifold gauge)
Gas releasing (Servicing)	Open	Open	Open (Connected manifold gauge)



## 11.1. Air Purging of the Piping and Indoor Unit

### 11.1.1. Air purging (Installation)

Required tools: hexagonal wrench, adjustable wrench, torque wrenches, wrench to hold the joints and gas leak detector.  
The additional gas for air purging has been charged in the outdoor unit.

However, if the flare connections have not been done correctly and there gas leaks, a gas cylinder and the charge set will be needed.

The air in the indoor unit and in the piping must be purged. If air remains in the refrigeration pipings, it will affect the compressor, reduce the cooling capacity, and could lead to a malfunction.

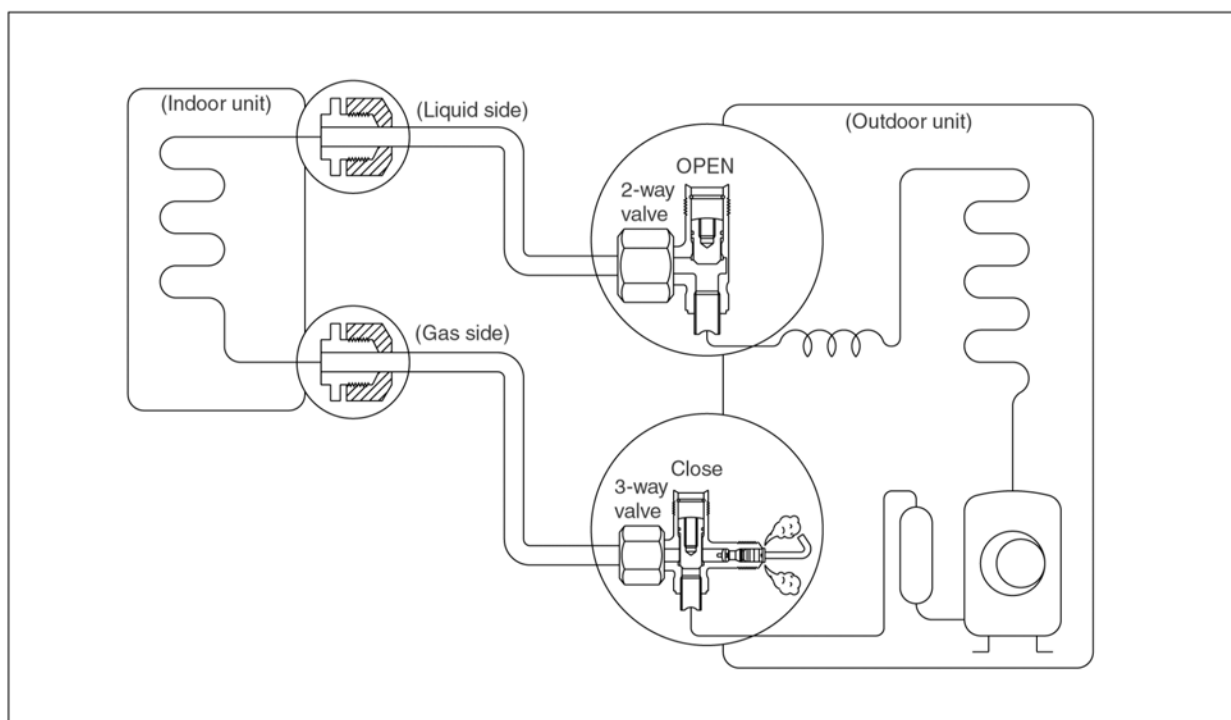

Service port cap

Be sure, using a torque wrench to tighten the service port cap (after using the service port), so that it prevents the gas leakage from the refrigeration cycle.

#### Procedure:

1. **Recheck the piping connections.**
2. **Open the valve stem of the 2-way valve counterclockwise approximately 90°, wait 10 seconds, and then set it to closed position.**
  - Be sure to use a hexagonal wrench to operate the valve stem.
3. **Check for gas leakage.**
  - Check the flare connection for gas leakage.
4. **Purge the air from the system**
  - Set the 2-way valve to the open position and remove the cap from the 3-way valve's service port.
  - Using the hexagonal wrench to press the valve core pin, discharge for three seconds and then wait for one minute.  
Repeat this three times.
5. **Use torque wrench to tighten the service port cap to a torque of 1.8 kg.m. (18 N.m).**
6. **Set the 3-way valve to the opened position.**
7. **Mount the valve stem nuts to the 2-way and 3-way valves.**
8. **Check for gas leakage.**
  - At this time, especially check for gas leakage from the 2-way and 3-way's stem nuts, and from the service port cap.

#### Caution

If gas leakage is discovered in step (3) above, take the following measures:

Tighten the piping connections. If the leaks stop, continue working from step (4).

If the gas leaks do not stop when the connections are retightened, repair the location of the leak, discharge all of the gas through the service port, and then recharge with the specified amount of gas from a gas cylinder.

## 11.1.2. Pumping down (Re-installation)

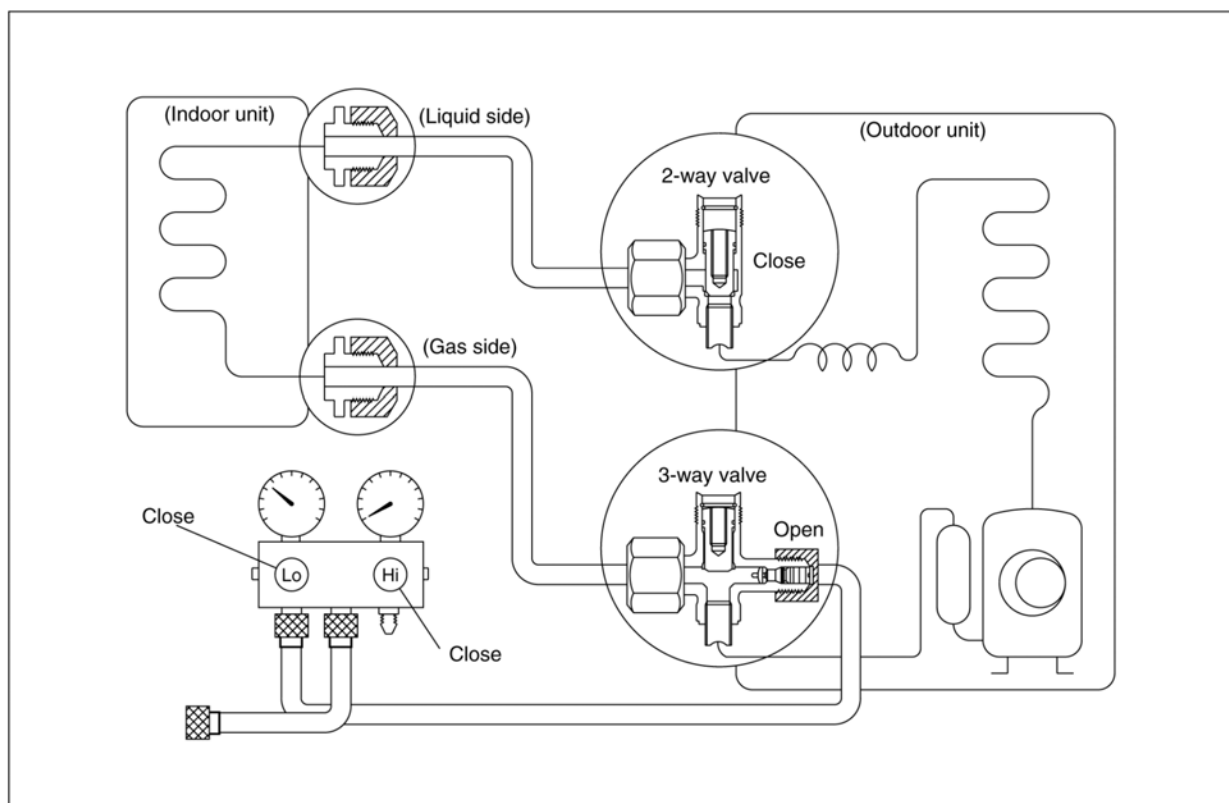

### Procedure:

1. **Confirm that both the 2-way and 3-way valves are set to the opened position.**
  - Remove the valve stem caps and confirm that the valve stems are in the opened position.
  - Be sure to use a hexagonal wrench to operate the valve stems.
2. **Operate the unit for 10 to 15 minutes.**
3. **Stop operation and wait for 3 minutes, then connect the charge set to the service port of the 3-way valve.**
  - Connect the charge hose with the push pin to the Gas service port.
4. **Air purging of the charge hose.**
  - Open the low-pressure valve on the charge set slightly to purge air from the charge hose.
5. **Set the 2-way valve to the close position.**
6. **Operate the air conditioner at the cooling cycle and stop it when the gauge indicates 1 kg/cm<sup>2</sup>G (0.1 MPa).**
7. **Immediately set the 3-way valve to the closed position.**
  - Do this quickly so that the gauge ends up indicating 3 to 5 kg/cm<sup>2</sup>G (0.3 to 0.5 MPa).
8. **Disconnect the charge set, and mount the 2-way and 3-way valve's stem nuts and the service port caps.**
  - Use a torque wrench to tighten the service port cap to a torque of 1.8 kg.m (18 N.m).
  - Be sure to check for gas leakage.

### 11.1.3. Re-air purging (Re-installation)

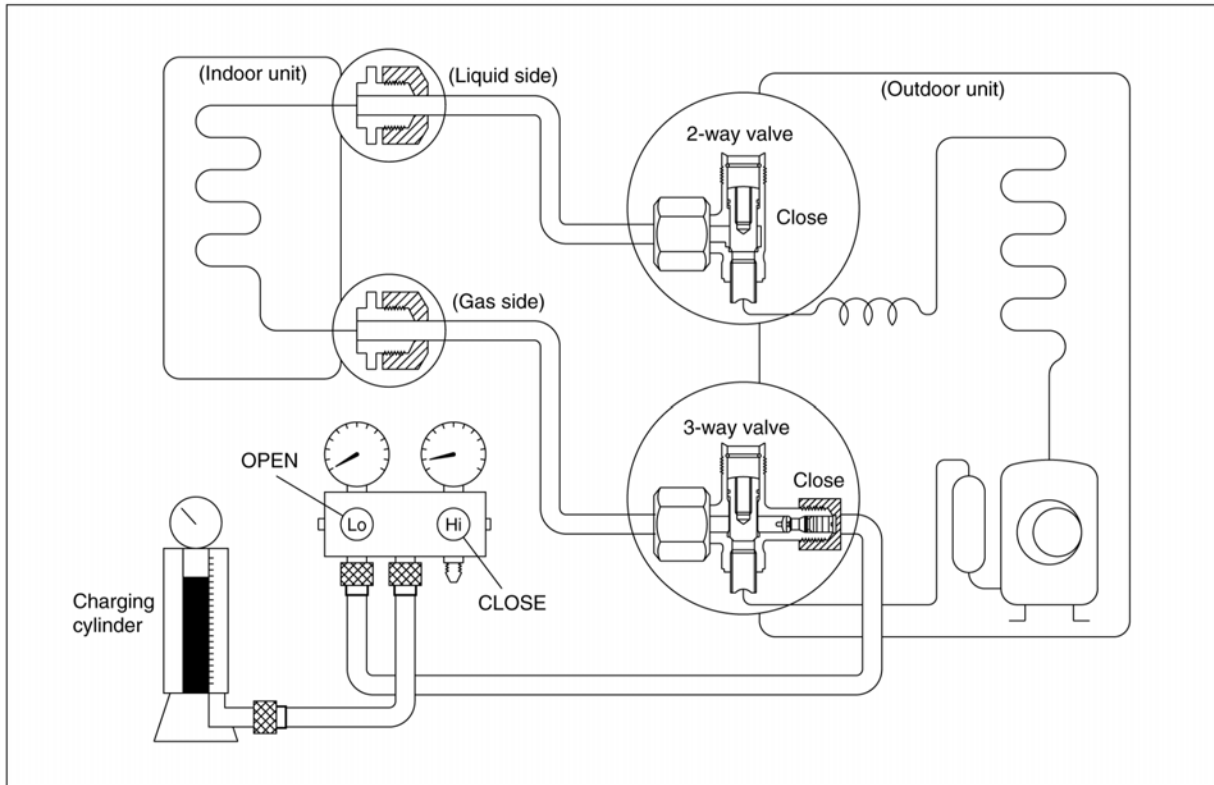

#### Procedure:

1. **Confirm that both the 2-way and 3-way valves are set to the closed position.**
2. **Connect the charge set and a charging cylinder to the service port of the 3-way valve.**
  - Leave the valve on the charging cylinder closed.
3. **Air purging.**
  - Open the valves on the charging cylinder and the charge set. Purge the air by loosening the flare nut on the 2-way valve approximately 45° for 3 seconds then closing it for 1 minute; repeat 3 times.
  - After purging the air, use a torque wrench to tighten the flare nut on the 2-way valve.
4. **Check for gas leakage.**
  - Check the flare connections for gas leakage.
5. **Discharge the refrigerant.**
  - Close the valve on the charging cylinder and discharge the refrigerant until the gauge indicates 3 to 5 kg/cm<sup>2</sup>G (0.3 to 0.5 MPa)
6. **Disconnect the charge set and the charging cylinder, and set the 2-way and 3-way valves to the open position.**
  - Be sure to use a hexagonal wrench to operate the valve stems.
7. **Mount the valve stem nuts and the service port cap.**
  - Be sure to use a torque wrench to tighten the service port cap to a torque 1.8 kg.m (18 N.m).
  - Be sure to check for gas leakage.

### 11.1.4. Balance refrigerant of the 2-way, 3-way valves

(Gas leakage)

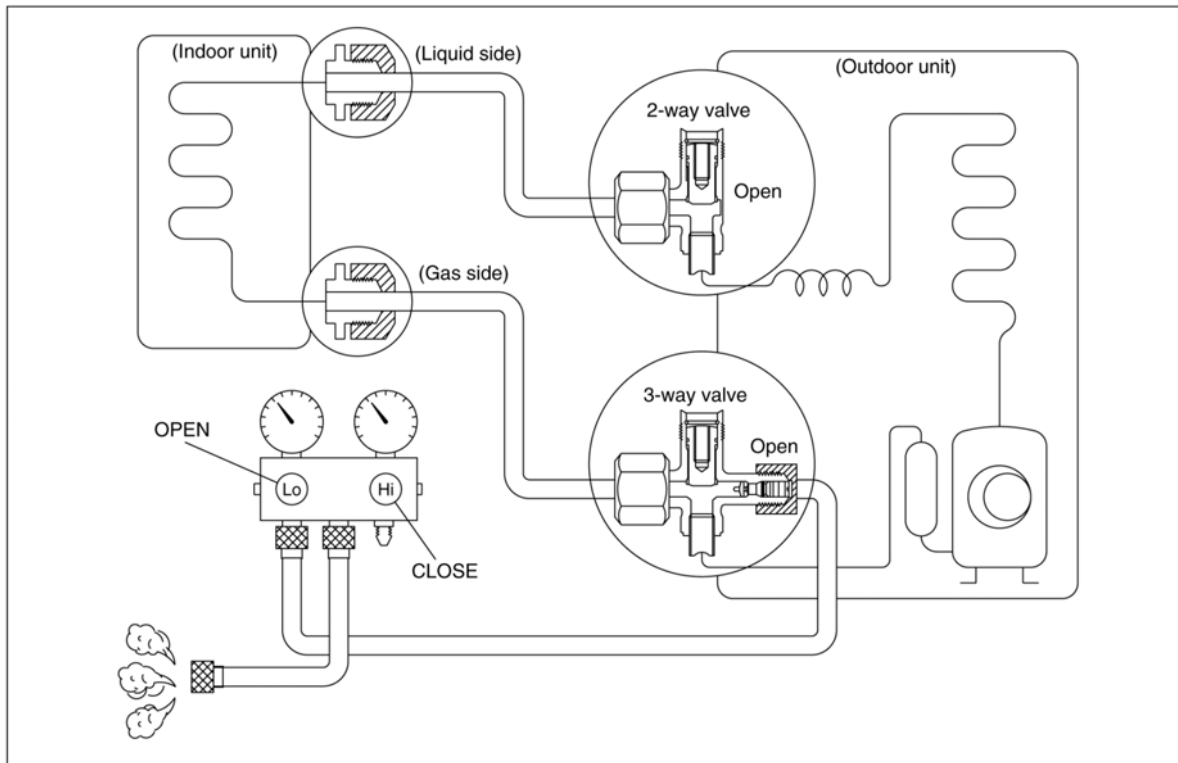

#### Procedure:

1. Confirm that both the 2-way and 3-way valves are set to the open position.
2. Connect the charge set to the 3-way valve's service port.
  - Leave the valve on the charge set closed.
  - Connect the charge hose with the push pin to the service port.
3. Open the valves (Low side) on the charge set and discharge the refrigerant until the gauge indicates 0.5 to 1 kg/cm<sup>2</sup>G (0.05 to 0.1 MPa).
  - If there is no air in the refrigeration cycle [ the pressure when the air conditioner is not running is higher than 1 kg/cm<sup>2</sup>G (0.1 MPa) ], discharge the refrigerant until the gauge indicates 0.5 to 1 kg/cm<sup>2</sup>G (0.05 to 0.1 MPa). If this is the case, it will not be necessary to apply a evacuation.
  - Discharge the refrigerant gradually; if it is discharged too suddenly, the refrigeration oil will be discharged.

### 11.1.5. Evacuation (Installation)

(No refrigerant in the refrigeration cycle)

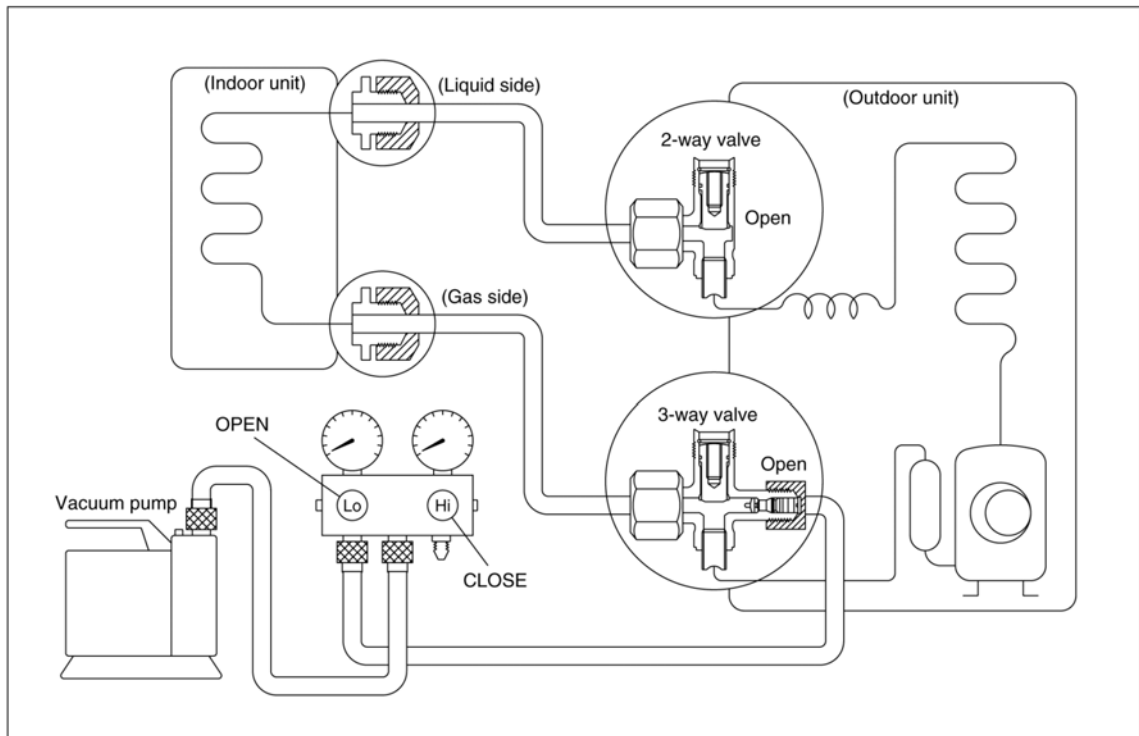

#### Procedure:

1. Connect the vacuum pump to the charge set's centre hose.
2. Evacuation for approximately one hour.
  - Confirm that the gauge needle has moved toward -0.1 MPa (-76 cmHg) [vacuum of 4 mmHg or less.]
3. Close the valve (Low side) on the charge set, turn off the vacuum pump, and confirm that the gauge needle does not move (approximately 5 minutes after turning off the vacuum pump).
4. Disconnect the charge hose from the vacuum pump.
  - Vacuum pump oil
    - If the vacuum pump oil becomes dirty or depleted, replenish as needed.

## 11.1.6. Gas charging

(After Evacuation)

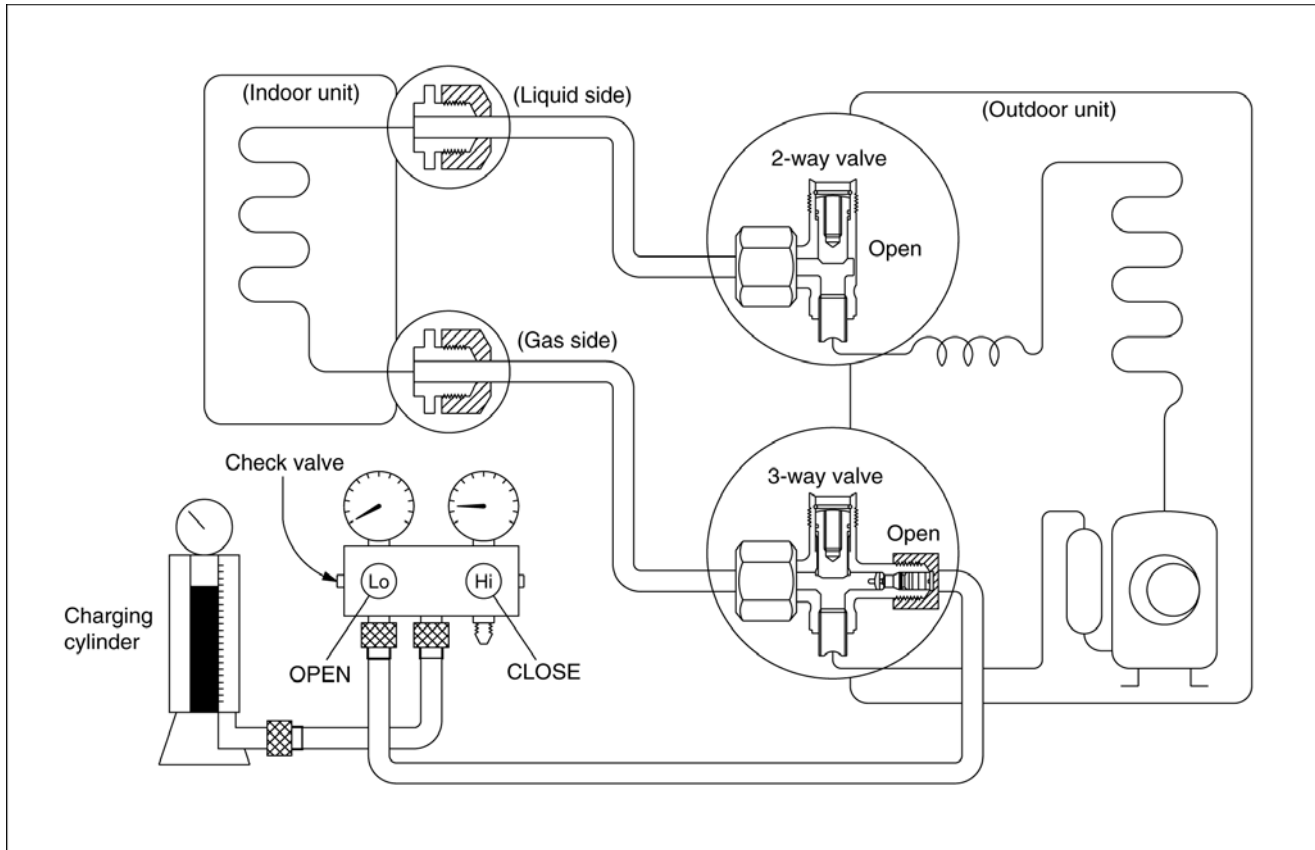

### Procedure:

#### 1. Connect the charge hose to the charging cylinder.

- Connect the charge hose which you disconnected from the vacuum pump to the valve at the bottom of the cylinder.

#### 2. Purge the air from the charge hose.

- Open the valve at the bottom of the cylinder and press the check valve on the charge set to purge the air (be careful of the liquid refrigerant).

#### 3. Open the valve (Low side) on the charge set and charge the system with liquid refrigerant.

- If the system cannot be charged with the specified amount of refrigerant, it can be charged with a little at a time (approximately 150 g each time) while operating the air conditioner in the cooling cycle; however, one time is not sufficient, wait approximately 1 minute and then repeat the procedure. (pumping down-pin)

This is different from previous procedures. Because you are charging with liquid refrigerant from the gas side, absolutely do no attempt to charge with large amount of liquid refrigerant while operating the air conditioner.

#### 4. Immediately disconnect the charge hose from the 3-way valve's service port.

- Stopping partway will allow the refrigerant to be discharged.
- If the system has been charged with liquid refrigerant while operating the air conditioner, turn off the air conditioner before disconnecting the hose.

#### 5. Mount the valve stem caps and the service port cap.

- Use torque wrench to tighten the service port cap to a torque of 18 N.m.
- Be sure to check for gas leakage.

## 12 Servicing Information

### 12.1. Distinction Of Lead Free (PbF) Printed Circuit Board

- Printed circuit boards (manufactured) using lead free solder will have a PbF stamp on the Printed Circuit board.

#### CAUTION

- Pb free solder has a higher melting point than standard solder; typically the melting point is 50 - 70°F (30 - 40°C) higher. Please use a high temperature solder iron and set it to 700 ± 20°F (370 ± 10°C).
- Pb free solder will tend to splash when heated too high (about 1100°F/600°C).
- If you must use Pb solder, please completely remove all of the Pb free solder on the pin or solder area before applying Pb solder. If this is not practical, be sure to heat the Pb free solder until it melts, before applying Pb solder.

### 12.2. Indoor Electronic Controllers Removal Procedures

- Electronic controller and Display Complete unit can be seen by following the below removal procedures.



Remove 2 caps and screws

Fig. 1

- Remove the 2 caps and 2 screws at the bottom of the Front Grille. (Fig. 1)



Front Grille Complete

Fig. 2

- Remove the Front Grille Complete. (Fig. 2)

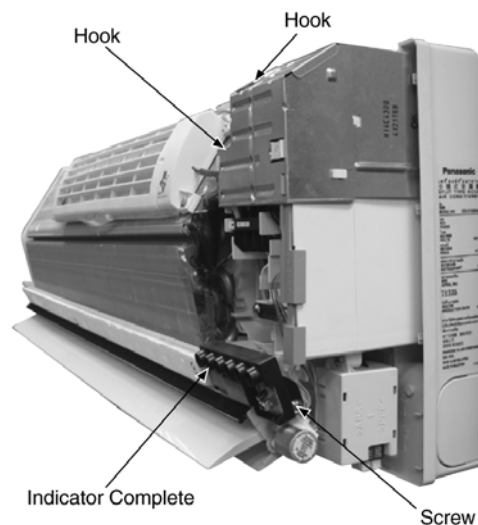

Fig. 3

- Release the taps on top and on the right side of metal plate cover. (Fig. 3)
- Then remove the metal plate cover. (Fig. 3)
- Remove the indicator complete screw, and then remove the indicator complete. (Fig. 3)

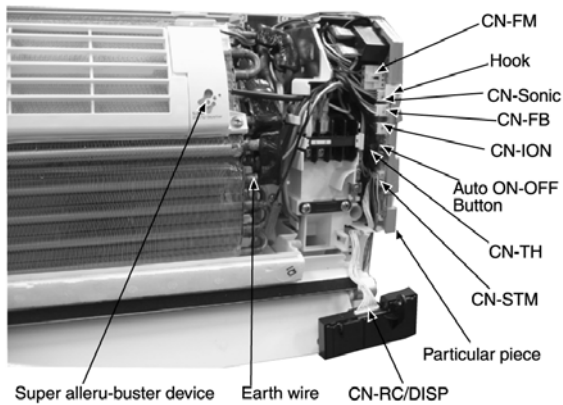

Fig. 4

- To remove the electronic controller.
- Release CN-FM connectors. (Fig. 4)
- Release CN-Sonic connector. (Fig. 4)
- Release CN-FB connector. (Fig. 4)
- Release CN-ION connector. (Fig. 4)
- Release CN-TH connector. (Fig. 4)
- Release CN-STM connector. (Fig. 4)
- Release CN-REC/DISP connector. (Fig. 4)

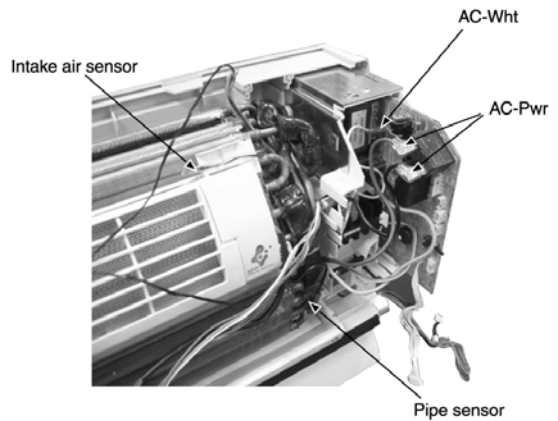

Fig. 5

- Press the hook to the right then take out the PCB. (Fig. 5)
- Release Ry-Pwr connector (black and brown) and Ac-Wht connector from the PCB. (Fig. 5)

### 12.3. Indoor Fan Motor And Cross Flow Fan Removal Procedures

- Remove Control Board Cover

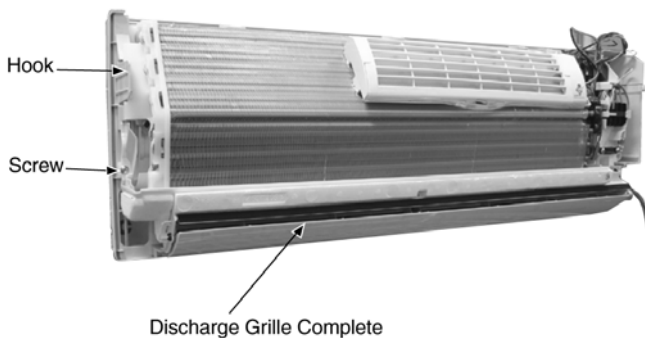

Fig. 6

- Remove the screw on the left of the unit. (Fig. 6)
- Pull the hook to the left and lift up the evaporator. (Fig. 6)
- Pull down the Discharge Grille Complete. (Fig. 6)

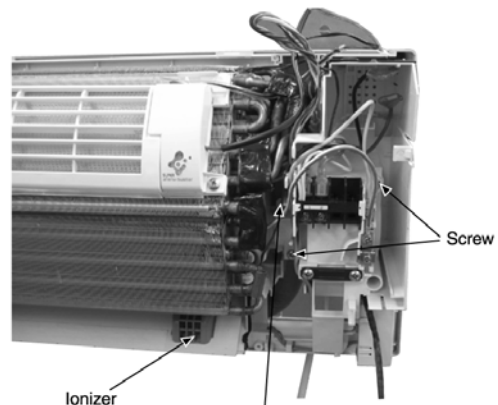

Fig. 7

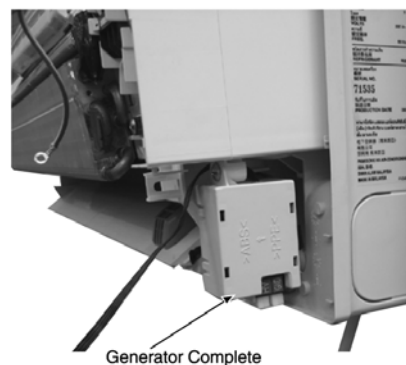

Fig. 8

- Remove indoor pipe sensor and air intake sensor from the evaporator. (Fig. 7)
- Remove the earth wire from the evaporator. (Fig. 7)



- Release the generator complete wire (green and red). (Fig. 8)
- Remove 2 screws on the right and 1 screw at the left side of the control board. (Fig. 7)
- Press down the hook on the left side of control board. (Fig. 7)
- Then pull out the Control Board Complete from the unit. (Fig. 7)

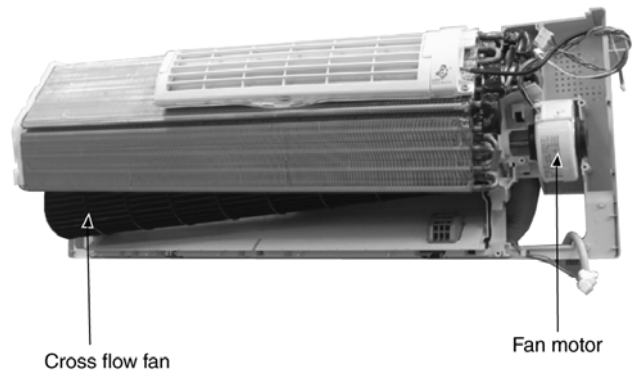

Fig. 10

- Push up the evaporator and remove cross flow fan by pulling both cross flow fan and fan motor. (Fig. 10)

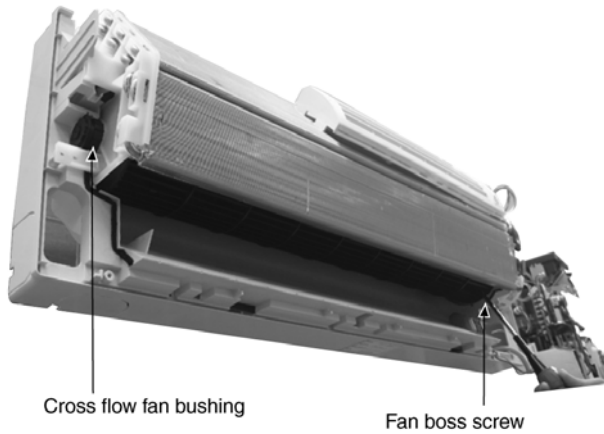
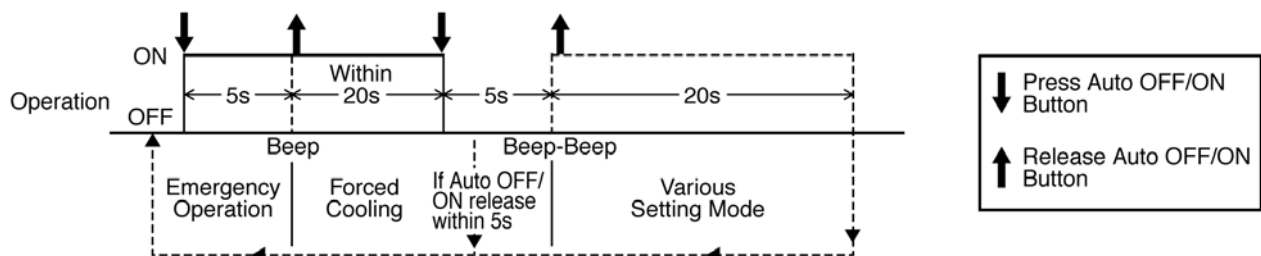

Fig. 9

- Remove the cross flow fan bushing from the chassis. (Fig. 9)
- Loosen the fan boss screw at the cross flow fan. (Fig. 9)

## 12.4. Auto OFF/ON Button

- The “Auto OFF/ON Button” (behind the front grille) is used to operate the air conditioner if remote control is misplaced or malfunctioning.
- Forced cooling operation is possible by pressing the “Auto OFF/ON Button” for more than 5s where “beep” sound is heard then release the button.
- User able to select remote control transmission code and toggle remote control signal receiving sound under various setting mode.
- To enter various setting mode:
  - Press the “Auto OFF/ON Button” continuously for 5s (“beep” sound is heard) and release.
  - Within 20s, press the “Auto OFF/ON Button” continuously for 5s again (2 “beep” sound is heard) and release.
  - Various setting mode has limit up to 20s. Then return to normal operation.



### 12.4.1. Toggle Remote Control Signal Receiving Sound

- Under various setting mode, press the “Auto OFF/ON Button” to toggle the remote control sound.
  - Short “beep”: Turn ON remote control signal receiving sound.

- Long “beep”: Turn OFF remote control signal receiving sound.
- After “Auto OFF/ON Button” is pressed, the 20s counter for various setting mode is restarted.

### 12.4.2. Select Remote Control Transmission Code

- There are 4 types of remote control transmission code could be selected and stored in EEPROM of indoor unit. The indoor unit will only operate when received signal with same transmission code from remote control. This could prevent signal interference when there are 2 or more indoor unit installed nearby together.
- To change remote control transmission code, short or open jumpers at the remote control printed circuit board.

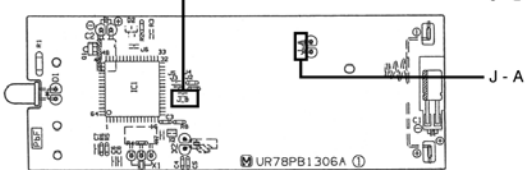
Remote Control Printed Circuit Board	Transmission Code Combination		
	J - A	J - B	Remote Control No.
	Short	Open	A (Default)
	Open	Open	B
	Short	Short	C
	Open	Short	D

- Under various setting mode, after select the transmission code combination of remote control, press any button of remote control to transmit a signal to indoor unit. The transmission code will be stored in EEPROM.
- After signal is received, the various setting mode is cancelled and return to normal operation.

### 12.5. Remote Control Reset

- When the batteries are inserted for the first time or the batteries are replaced, you may notice the indications at remote control's display screen blink continuously and not functionable. If this condition happens, try to reset the remote control by pushing the reset terminal with a pointing device.
- You may also do the reset to erase the setting at remote control and restore back the default setting.

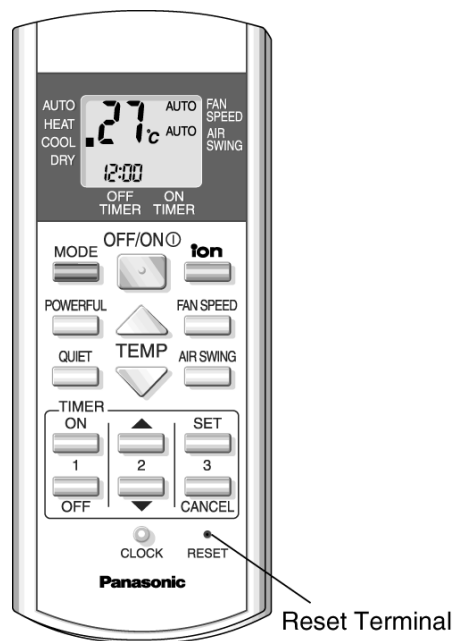

# 13 Troubleshooting Guide

## 13.1. Refrigeration Cycle System

In order to diagnose malfunctions, make sure that there are no electrical problems before inspecting the refrigeration cycle. Such problems include insufficient insulation, problem with the power source, malfunction of a compressor and a fan.

The normal outlet air temperature and pressure of the refrigeration cycle depends on various conditions, the standard values for them are shown in the table to the right.

Normal Pressure and Outlet Air Temperature (Standard)

	Gas pressure Mpa (kg/cm <sup>2</sup> G)	Outlet air temperature (°C)
Cooling Mode	0.9 ~ 1.2 (9 ~ 12)	10 ~ 16
Heating Mode	2.1 ~ 3.5 (21 ~ 35)	30 ~ 45

\* Condition: Indoor fan speed; High  
Outdoor temperature 35°C at the cooling mode and 7°C at the heating mode

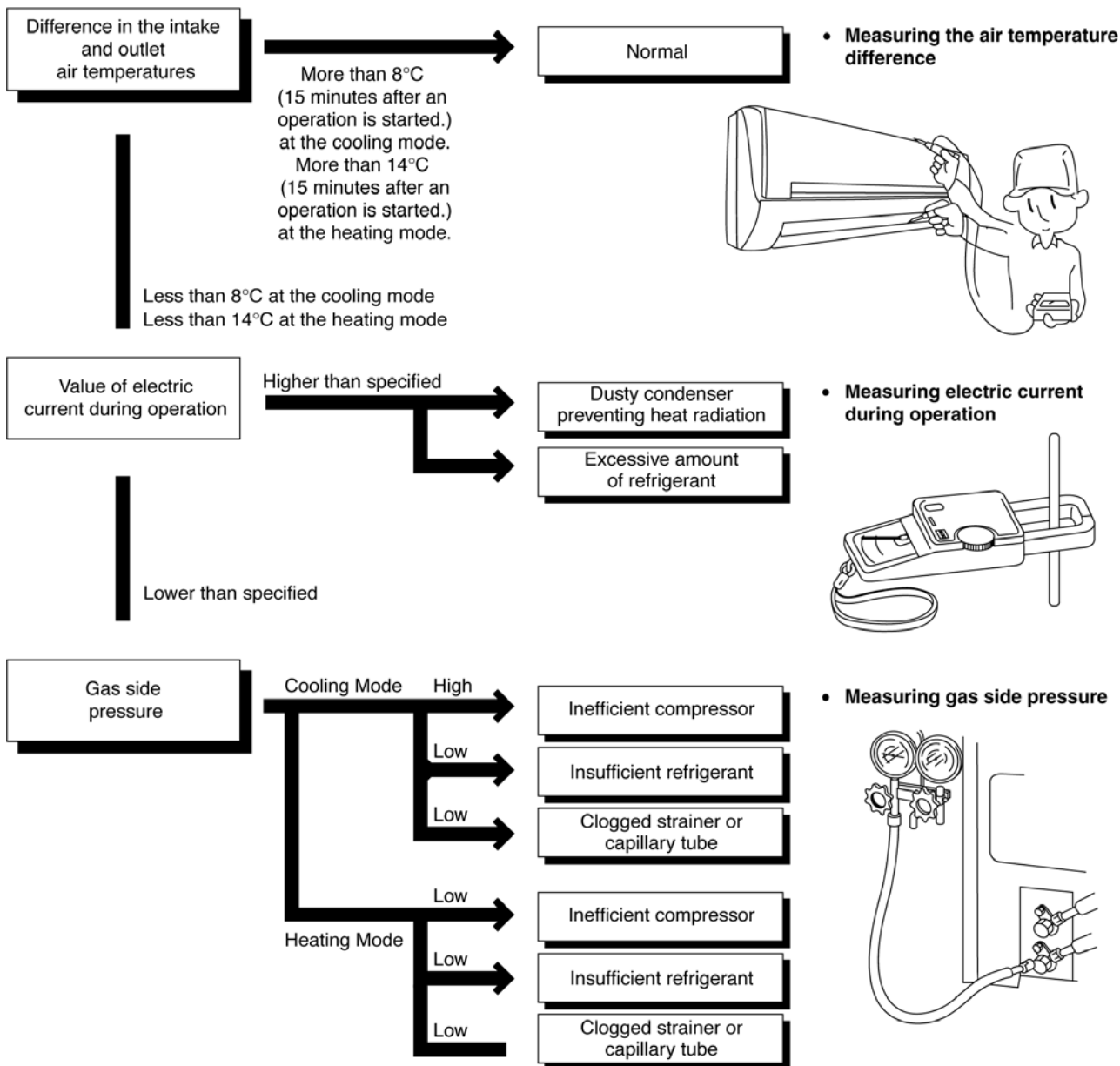

### 13.2. Relationship Between The Condition Of The Air Conditioner And Pressure And Electric Current

Condition of the air conditioner	Cooling Mode			Heating Mode		
	Low Pressure	High Pressure	Electric current during operation	Low Pressure	High Pressure	Electric current during operation
Insufficient refrigerant (gas leakage)	↘	↘	↘	↘	↘	↘
Clogged capillary tube or Strainer	↘	↘	↘	↘	↘	↘
Short circuit in the indoor unit	↘	↘	↘	↗	↗	↗
Heat radiation deficiency of the outdoor unit	↗	↗	↗	↘	↘	↘
Inefficient compression	↗	↘	↘	↗	↘	↘

- Carry out the measurements of pressure, electric current, and temperature fifteen minutes after an operation is started.

### 13.3. Diagnosis Methods Of A Malfunction Of A Compressor And 4-way Valve

Nature of fault	Symptom
Insufficient compressing of a compressor	<ul style="list-style-type: none"> <li>• Electric current during operation becomes approximately 20% lower than the normal value.</li> <li>• The discharge tube of the compressor becomes abnormally hot (normally 70 to 90°C).</li> <li>• The difference between high pressure and low pressure becomes almost zero.</li> </ul>
Locked compressor	<ul style="list-style-type: none"> <li>• Electric current reaches a high level abnormally, and the value exceeds the limit of an ammeter. In some cases, a breaker turns off.</li> <li>• The compressor is a humming sound.</li> </ul>
Insufficient switches of the 4-way valve	<ul style="list-style-type: none"> <li>• Electric current during operation becomes approximately 80% lower than the normal value.</li> <li>• The temperature different between from the discharge tube to the 4-way valve and from suction tube to the 4-way valve becomes almost zero.</li> </ul>

# 14 Technical Data

## 14.1. Thermostat Characteristics

### 14.1.1. CS-A7DKD / CS-A9DKD / CS-A12DKD

• **Cooling**

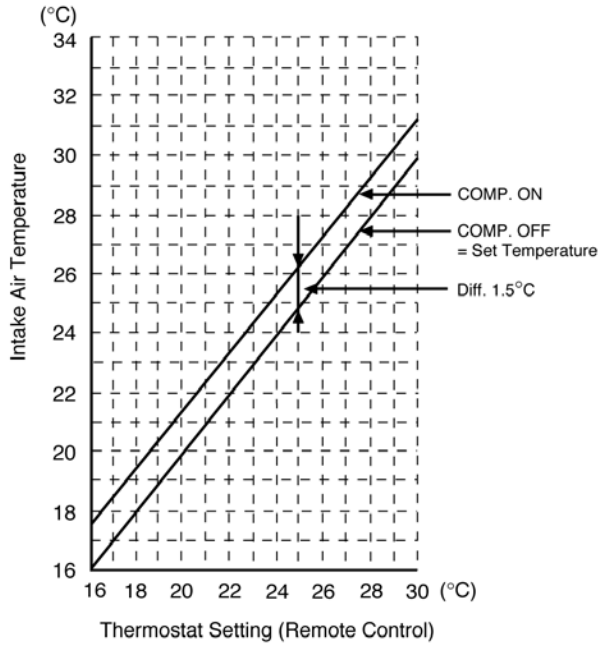

• **Soft Dry**

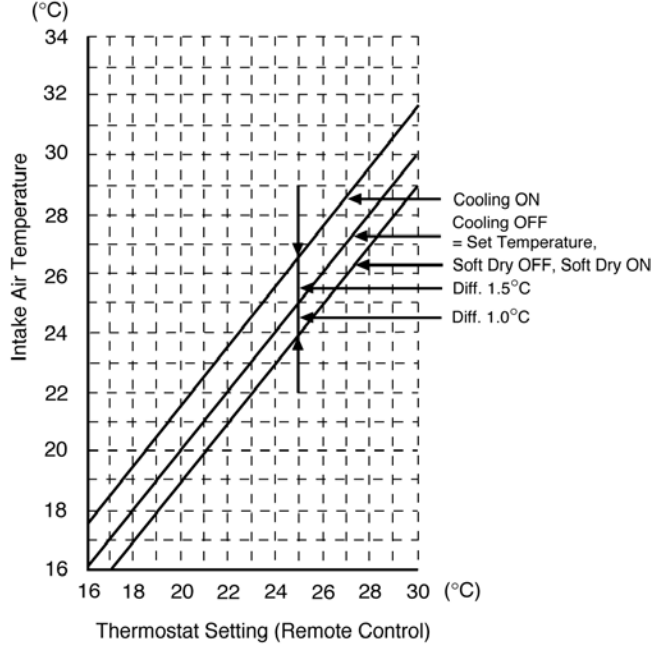

• **Heating**

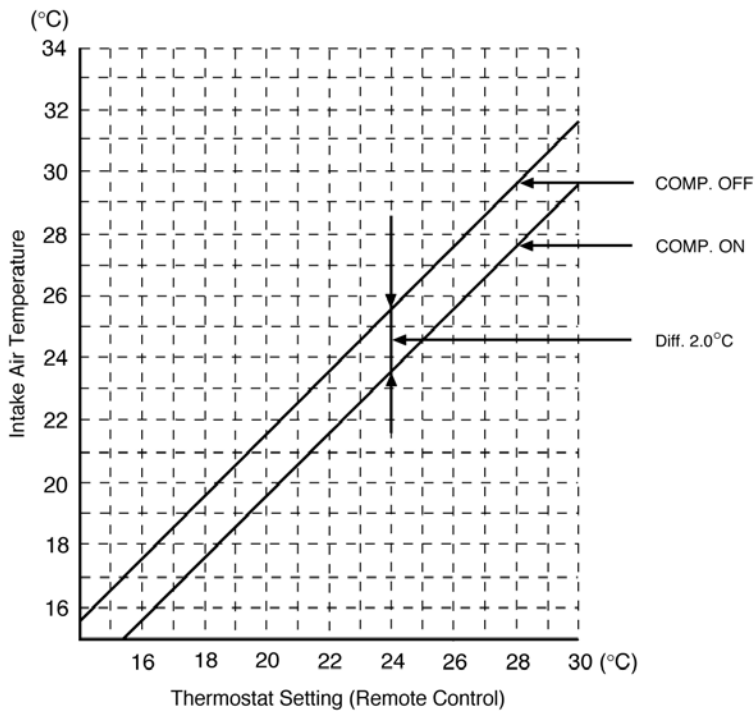

## 14.2. Operation Characteristics

### 14.2.1. CS-A7DKD CU-A7DKD

#### • Cooling Characteristic

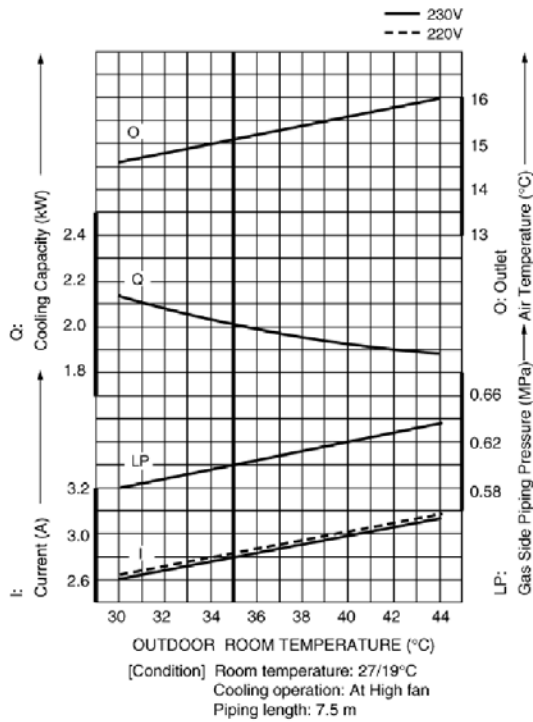

#### • Piping Length Characteristic (Cooling)

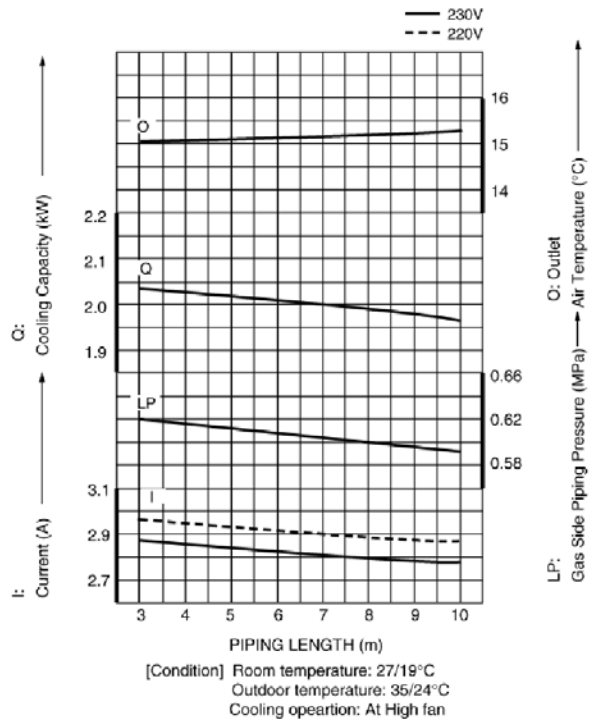

#### • Heating Characteristic

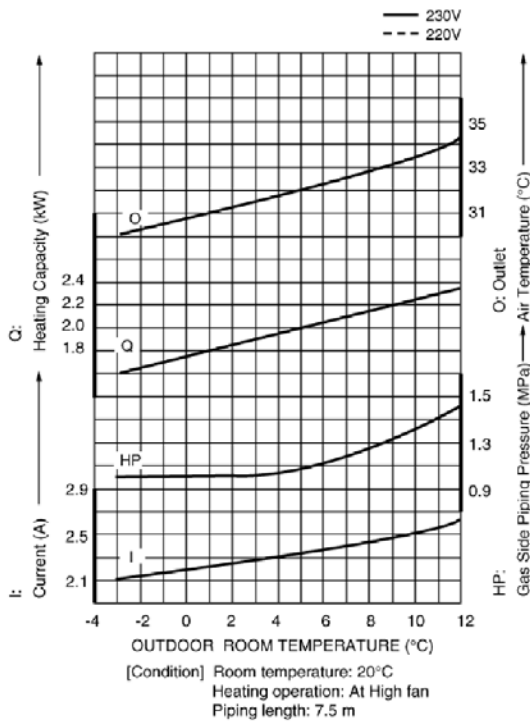

#### • Piping Length Characteristic (Heating)

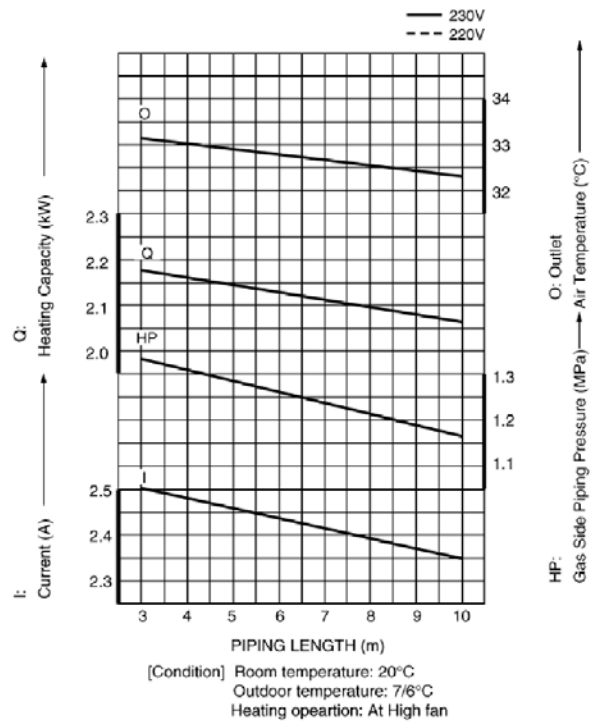

### 14.2.2. CS-A9DKD CU-A9DKD

#### • Cooling Characteristic

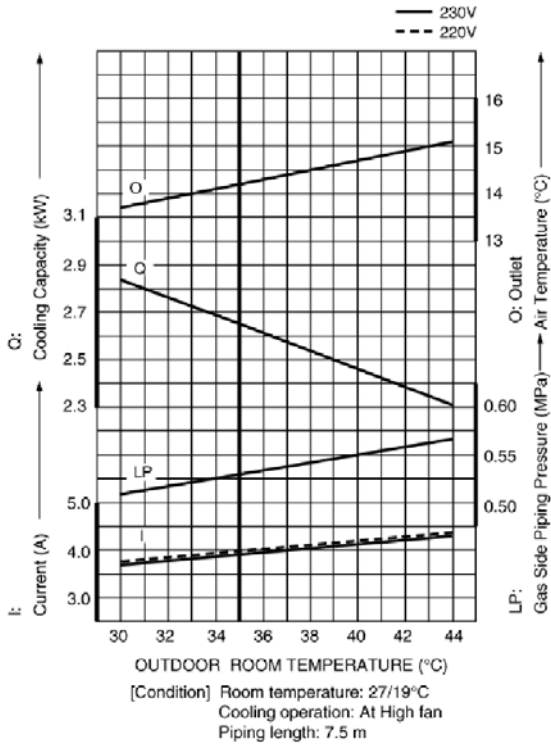

#### • Piping Length Characteristic (Cooling)

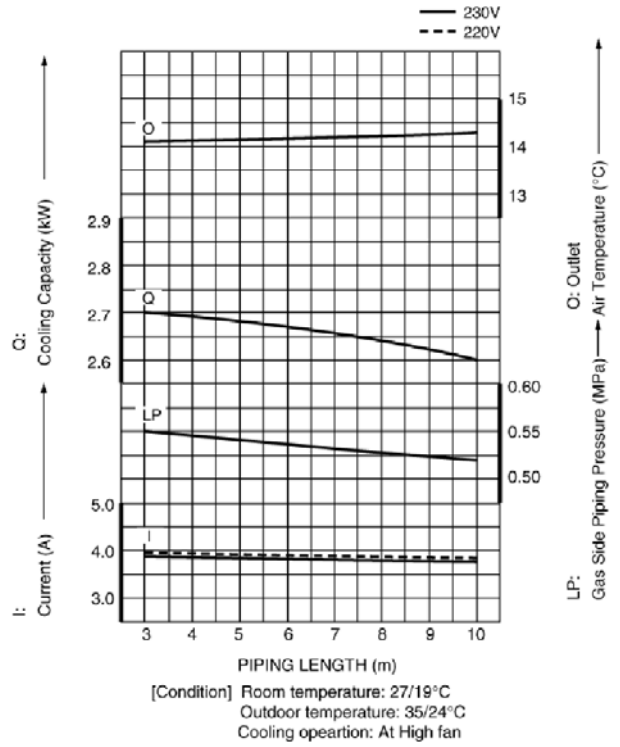

#### • Heating Characteristic

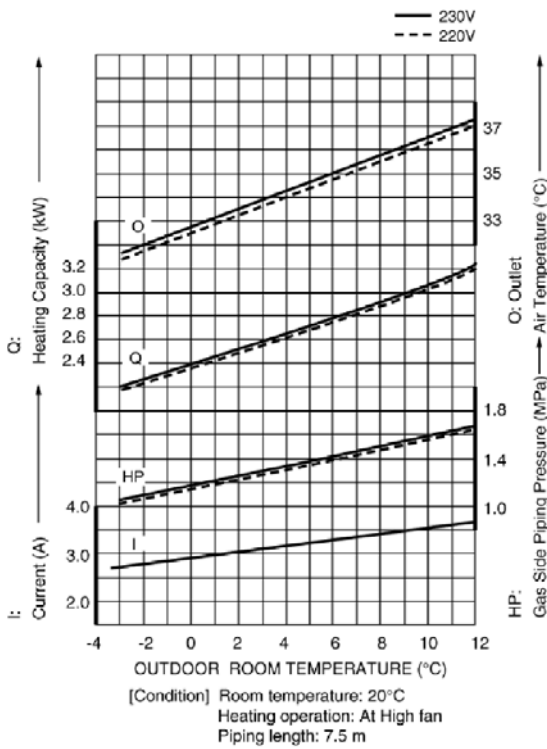

#### • Piping Length Characteristic (Heating)

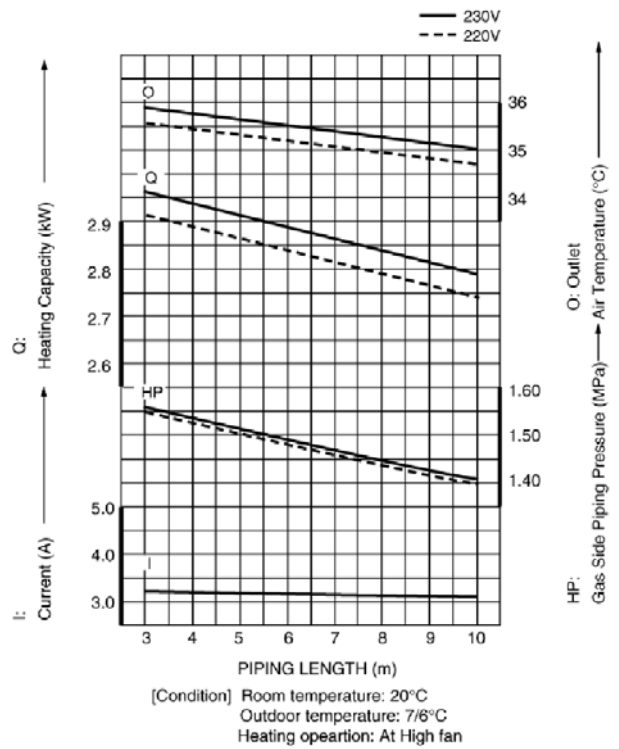

### 14.2.3. CS-A12DKD CU-A12DKD

#### • Cooling Characteristic

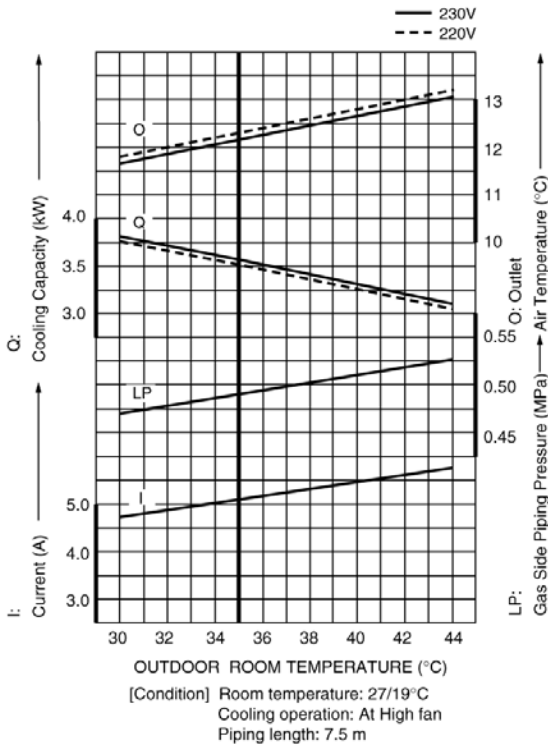

#### • Piping Length Characteristic (Cooling)

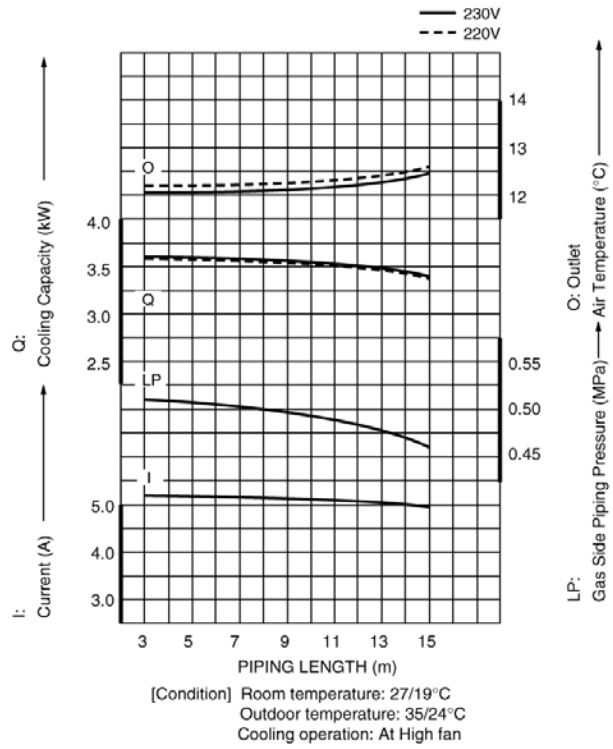

#### • Heating Characteristic

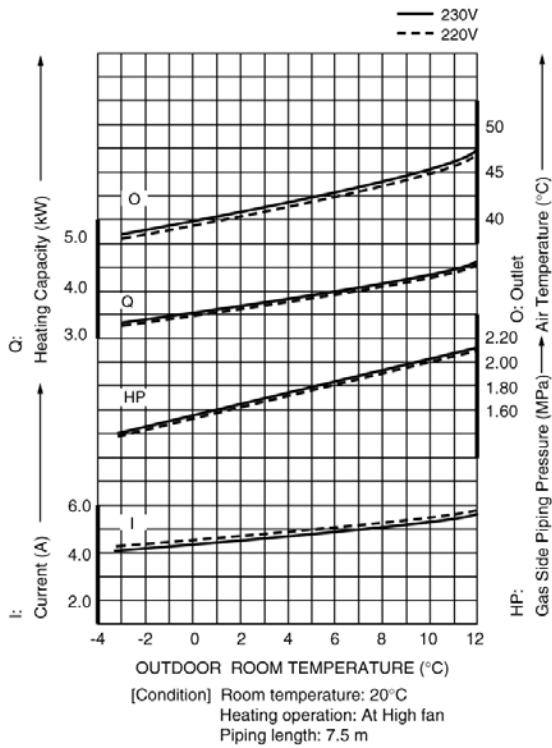

#### • Piping Length Characteristic (Heating)

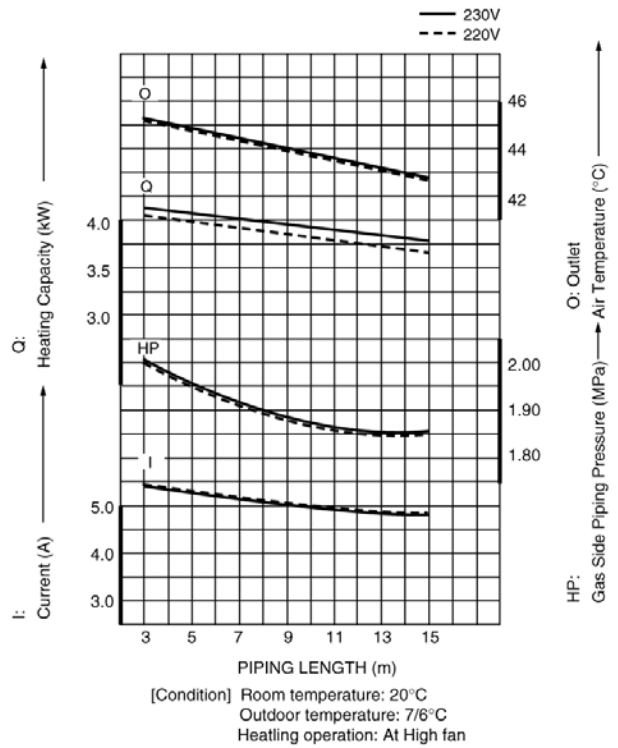



# 15 Exploded View (Indoor Unit)

## 15.1. CS-A7DKD CS-A9DKD CS-A12DKD

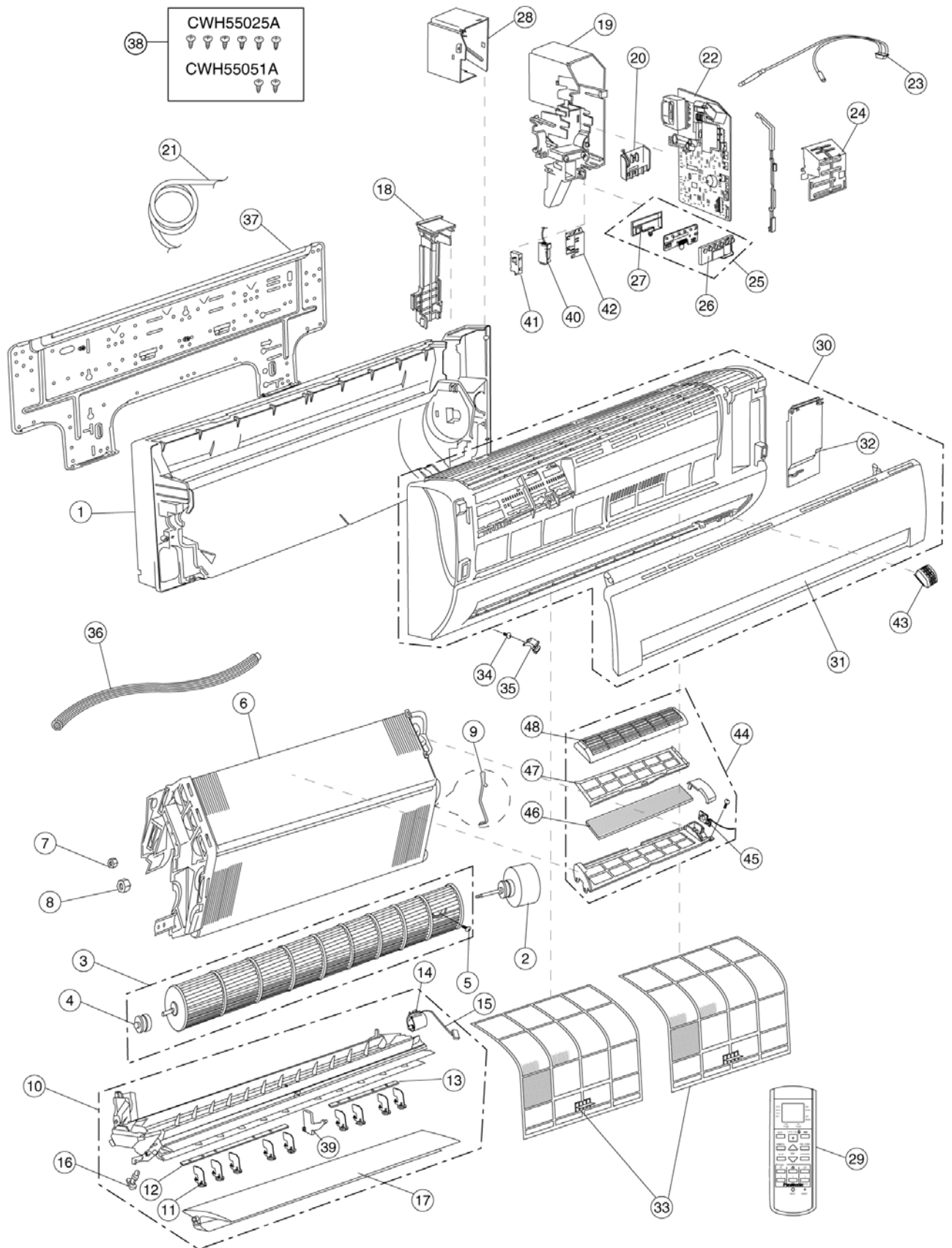

**Note:**

The above exploded view is for the purpose of parts disassembly and replacement.

The non-numbered parts are not kept as standard service parts.

# 16 Replacement Parts List (Indoor Unit)

<Model: CS-A7DKD / CS-A9DKD / CS-A12DKD >

REF. NO.	PART NAME & DESCRIPTION	QTY.	CS-A7DKD	CS-A9DKD	CS-A12DKD	REMARKS
1	CHASSY COMPLETE	1	CWD50C1377	←	←	
2	FAN MOTOR	1	CWA921181	CWA921324	CWA921181	0
3	CROSS FLOW FAN COMPLETE	1	CWH02C1031	←	←	
4	BEARING ASS'Y	1	CWH64K007	←	←	
5	SCREW - CROSS FLOW FAN	1	CWH4580304	←	←	
6	EVAPORATOR	1	CWB30C1600	CWB30C1687	CWB30C1601	
7	FLARE NUT	1	CWT25078 (1/4")	←	←	
8	FLARE NUT	1	CWT25005 (3/8")	←	CWT25007 (1/2")	
9	INTAKE AIR SENSOR COMPLETE	1	CWH32143	←	←	
10	DISCHARGE GRILLE COMPLETE	1	CWE20C2366	←	←	
11	VERTICAL VANE	9	CWE241150	←	←	
12	CONNECTING BAR	1	CWE261066	←	←	
13	CONNECTING BAR	1	CWE261070	←	←	
14	AIR SWING MOTOR	1	CWA98260	←	←	0
15	LEAD WIRE - AIR SWING MOTOR	1	CWA67C3977	←	←	
16	CAP - DRAIN TRAY	1	CWH521096	←	←	
17	HORIZONTAL VANE	1	CWE241173	←	←	
18	BACK COVER CHASSIS	1	CWD932454	←	←	
19	CONTROL BOARD CASING	1	CWH102259	←	←	
20	TERMINAL BOARD COMPLETE	1	CWA28C2074	←	CWA28C2071	0
21	POWER SUPPLY CORD	1	CWA20C2159	←	←	
22	ELECTRONIC CONTROLLER - MAIN	1	CWA743557	CWA743508	CWA743558	0
23	SENSOR COMPLETE	1	CWA50C2122	←	←	0
24	CONTROL BOARD FRONT COVER	1	CWH131207	←	←	
25	INDICATOR COMPLETE	1	CWE39C1115	←	←	0
26	INDICATOR HOLDER	1	CWD932429	←	←	
27	INDICATOR HOLDER	1	CWD932430	←	←	
28	CONTROL BOARD COVER COMPLETE	1	CWH13C1120	←	←	
29	REMOTE CONTROL COMPLETE	1	CWA75C2604	←	←	0
30	FRONT GRILLE COMPLETE	1	CWE11C3125	←	←	
31	INTAKE GRILLE COMPLETE	1	CWE22C1154	←	←	
32	GRILLE DOOR	1	CWE141073	←	←	
33	AIR FILTER	2	CWD001144	←	←	
34	SCREW - FRONT GRILLE	2	XTN4+16C	←	←	
35	CAP - FRONT GRILLE	2	CWH521109	←	←	
36	DRAIN HOSE	1	CWH851063	←	←	
37	INSTALLATION PLATE	1	CWH361067	←	←	
38	BAG COMPLETE - INSTALLATION SCREW	1	CWH82C067	←	←	
39	FULCRUM	1	CWH621046	←	←	
40	ELECTRONIC CONTROLLER - IONIZER	1	CWA743675	←	←	0
41	CASING - IONIZER	1	CWD932464	←	←	
42	CASING - IONIZER	1	CWD932431	←	←	
43	ION GENERATOR	1	CWH94C0001	←	←	
44	SUPERSONIC AIR PURIFYING DEVICE	1	CWH91C1013	←	←	
45	ELECTRONIC CONTROLLER - SUPERSONIC	1	CWA743874	←	←	0
46	SUPER ALLERU BUSTER FILTER	1	CWD00C1133	←	←	
47	FRAME FR AIR FILTER SUPERSONIC	1	CWD011026	←	←	
48	FRAME FR AIR FILTER SUPERSONIC	1	CWD011027	←	←	

(Note)

- All parts are supplied from PHAAM, Malaysia (Vendor Code: 061).
- "0" marked parts are recommended to be kept in stock.

# 17 Exploded View (Outdoor Unit)

## 17.1. CU-A7DKD CU-A9DKD

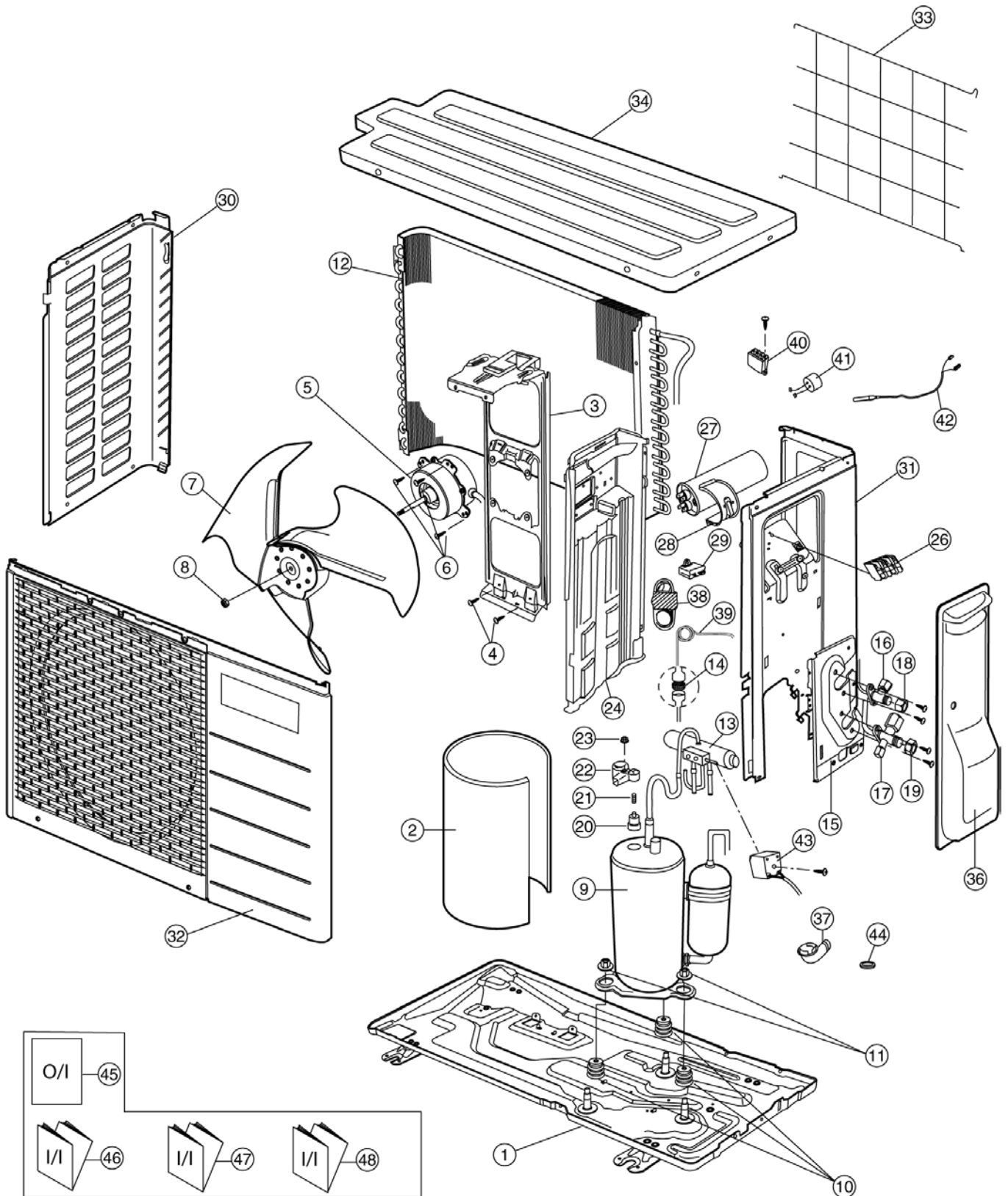

Note:

The above exploded view is for the purpose of parts disassembly and replacement.

The non-numbered parts are not kept as standard service parts.

## 17.2. CU-A12DKD

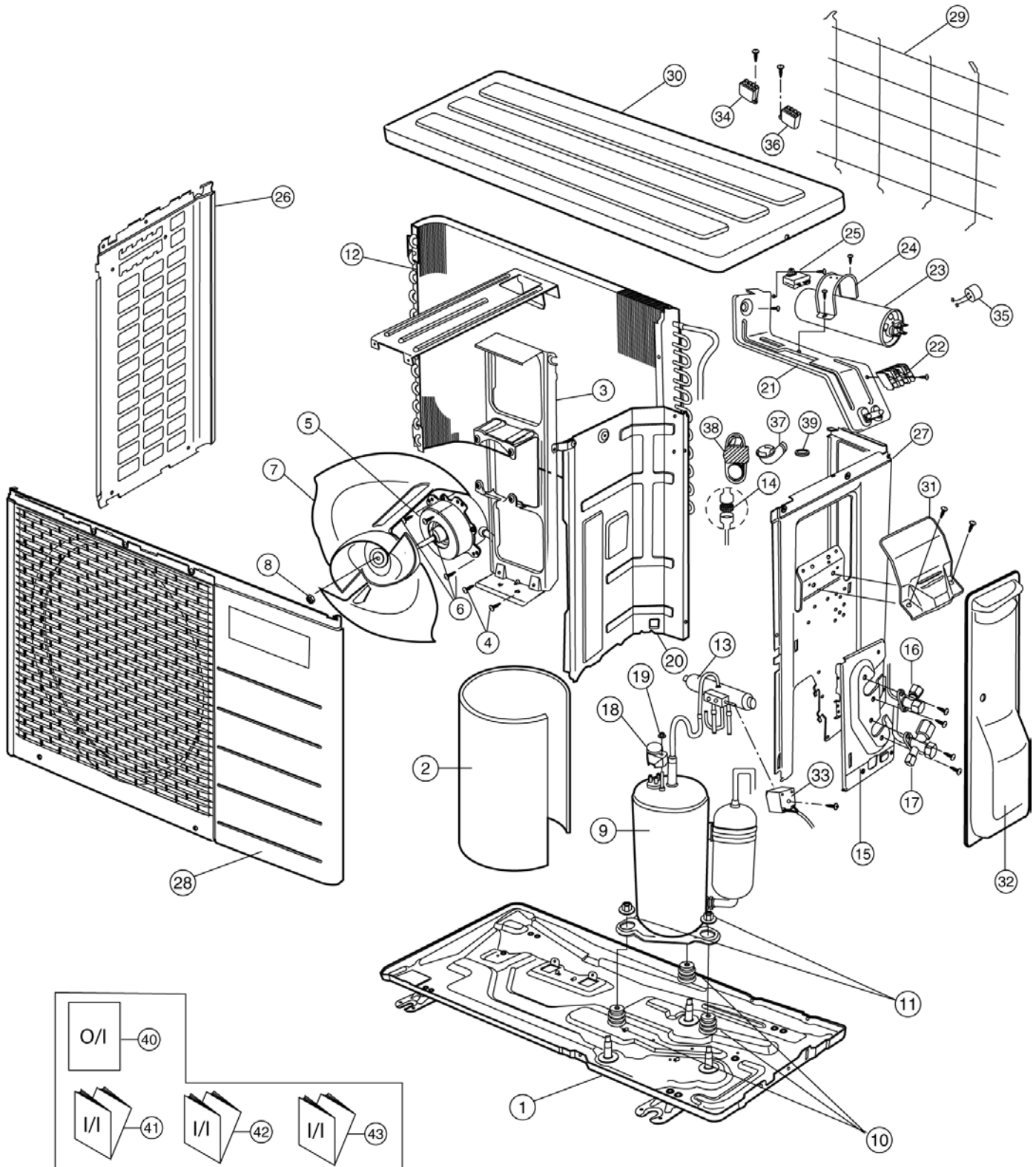

**Note:**

The above exploded view is for the purpose of parts disassembly and replacement.

The non-numbered parts are not kept as standard service parts.

# 18 Replacement Parts List (Outdoor Unit)

<Model: CU-A7DKD / CU-A9DKD>

REF. NO.	PART NAME & DESCRIPTION	QTY.	CU-A7DKD	CU-A9DKD	REMARKS
1	CHASSY ASS'Y	1	CWD50K2112	←	
2	SOUND PROOF MATERIAL	1	CWG302255	←	
3	FAN MOTOR BRACKET	1	CWD541075	←	
4	SCREW - FAN MOTOR BRACKET	2	CWH551060	←	
5	FAN MOTOR	1	CWA951388	←	0
6	SCREW - FAN MOTOR MOUNT	3	CWH55406	←	
7	PROPELLER FAN ASS'Y	1	CWH03K1020	←	
8	NUT - PROPELLER FAN	1	CWH56053	←	
9	COMPRESSOR	1	2RS122D5BC02	2PS156D3BB02	0
10	ANTI - VIBRATION BUSHING	3	CWH50077	←	0
11	NUT - COMPRESSOR MOUNT	3	CWH56000	←	
12	CONDENSER	1	CWB32C1493	←	
13	4-WAY VALVE	1	CWB001012	←	
14	STRAINER	1	CWB11025	←	
15	HOLDER COUPLING	1	CWH351047	←	
16	2-WAY VALVE (LIQUID)	1	CWB021218	CWB021217	0
17	3-WAY VALVE (GAS)	1	CWB011258	CWB011257	0
18	FLARE NUT (1/4")	1	CWT25078	←	
19	FLARE NUT (3/8")	1	CWT25005	←	
20	OVERLOAD PROTECTOR	1	CWA121050	CWA121091	0
21	HOLDER - O.L.P.	1	CWH7041200	←	
22	TERMINAL COVER	1	CWH171011	←	
23	NUT - TERMINAL COVER	1	CWH7080300	←	
24	SOUND PROOF BOARD	1	CWH151074	←	
25	CONTROL BOARD	1	-	-	
26	TERMINAL BOARD ASS'Y	1	CWA28K1021	←	0
27	CAPACITOR - COMPRESSOR	1	DS371206CPNA	DS371306CPND	0
28	HOLDER CAPACITOR	1	CWH301038	CWH301035	
29	CAPACITOR - FAN MOTOR	1	DS441205NPQA	←	0
30	CABINET SIDE PLATE (L)	1	CWE041110A	←	
31	CABINET SIDE PLATE (R)	1	CWE04C1042	←	
32	CABINET FRONT PLATE	1	CWE06K1048	←	
33	WIRE NET	1	CWD041057A	←	
34	CABINET TOP PLATE	1	CWE031041A	←	
36	CONTROL BOARD COVER	1	CWH13C1099	←	
37	L. TUBE	1	CWH5850080	←	
38	TUBE ASSY (CHK VALVE, CAPILLARY)	1	CWT01C3216	-	
39	CAPILLARY TUBE ASSY	1	-	CWB15K1146	
40	ELECTRO MAGNETIC SWITCH	1	CWA00059	←	
41	ELECTROLYTIC CAPACITOR	1	CWA32C1003	←	
42	TEMPERATURE RELAY	1	CWA14C1009	←	
43	V-COIL COMPLETE	1	CWA43C2174	←	
44	PACKING - L. TUBE	1	CWB81012	←	
45	OPERATING INSTRUCTIONS	1	CWH564479	←	
46	INSTALLATION INSTRUCTIONS	1	CWF612620	←	
47	INSTALLATION INSTRUCTIONS	1	CWF612681	←	
48	INSTALLATION INSTRUCTIONS	1	CWF612738	←	

(Note)

- All parts are supplied from PHAAM, Malaysia (Vendor Code: 061).
- "O" marked parts are recommended to be kept in stock.

## &lt;Model: CU-A12DKD&gt;

REF. NO.	PART NAME & DESCRIPTION	QTY.	CU-A12DKD	REMARKS
1	CHASSY ASS'Y	1	CWD50K2074	
2	SOUND PROOF MATERIAL	1	CWG302110	
3	FAN MOTOR BRACKET	1	CWD541030	
4	SCREW - FAN MOTOR BRACKET	2	CWH551059	
5	FAN MOTOR	1	CWA951117	0
6	SCREW - FAN MOTOR MOUNT	3	CWH55406	
7	PROPELLER FAN ASS'Y	1	CWH03K1006	
8	NUT - PROPELLER FAN	1	CWH56053	
9	COMPRESSOR	1	2KS206D5AF04	0
10	ANTI - VIBRATION BUSHING	3	CWH50055	0
11	NUT - COMPRESSOR MOUNT	3	CWH4582065	
12	CONDENSER	1	CWB32C1266	
13	4-WAY VALVE	1	CWB00003	
14	STRAINER	1	CWB11025	
15	HOLDER COUPLING ASS'Y	1	CWH351023	
16	2-WAY VALVE (LIQUID)	1	CWB021117	0
17	3-WAY VALVE (GAS)	1	CWB011148	0
18	TERMINAL COVER	1	CWH171012	
19	NUT - TERMINAL COVER	1	CWH7080300	
20	SOUND PROOF BOARD	1	CWH151023	
21	CONTROL BOARD	1	CWH102102	
22	TERMINAL BOARD ASS'Y	1	CWA28C2170	0
23	CAPACITOR - COMPRESSOR	1	DS371356CPNA	0
24	HOLDER CAPACITOR	1	CWH30057	
25	CAPACITOR - FAN MOTOR	1	DS441205NPOA	0
26	CABINET SIDE PLATE (L)	1	CWE041031A	
27	CABINET SIDE PLATE (R)	1	CWE041037A	
28	CABINET FRONT PLATE	1	CWE06K1034	
29	WIRE NET	1	CWD04C1009	
30	CABINET TOP PLATE	1	CWE031014A	
31	PLATE - C.B. COVER	1	CWH131088	
32	CONTROL BOARD COVER	1	CWH13C1065	
33	V-COIL COMPLETE	1	CWA43C2054	
34	ELECTRO MAGNETIC SWITCH	1	CWA00059	
35	ELECTROLYTIC CAPACITOR	1	CWA32C067	
36	ELECTRO MAGNETIC SWITCH	1	K6A2C7A00002	0
37	L. TUBE	1	CWH5850080	
38	TUBE ASS'Y (CHECK VALVE/ CAPILLARY)	1	CWT01C2640	
39	PACKING - L. TUBE	1	CWB81012	
40	OPERATING INSTRUCTIONS	1	CWH564479	
41	INSTALLATION INSTRUCTIONS	1	CWF612620	
42	INSTALLATION INSTRUCTIONS	1	CWF612681	
42	INSTALLATION INSTRUCTIONS	1	CWF612738	

## (Note)

- All parts are supplied from PHAAM, Malaysia (Vendor Code: 061).
- "O" marked parts are recommended to be kept in stock.

# 19 Electronic Circuit Diagram

## 19.1. Indoor Unit & Outdoor Unit

SCHEMATIC DIAGRAM 1/4

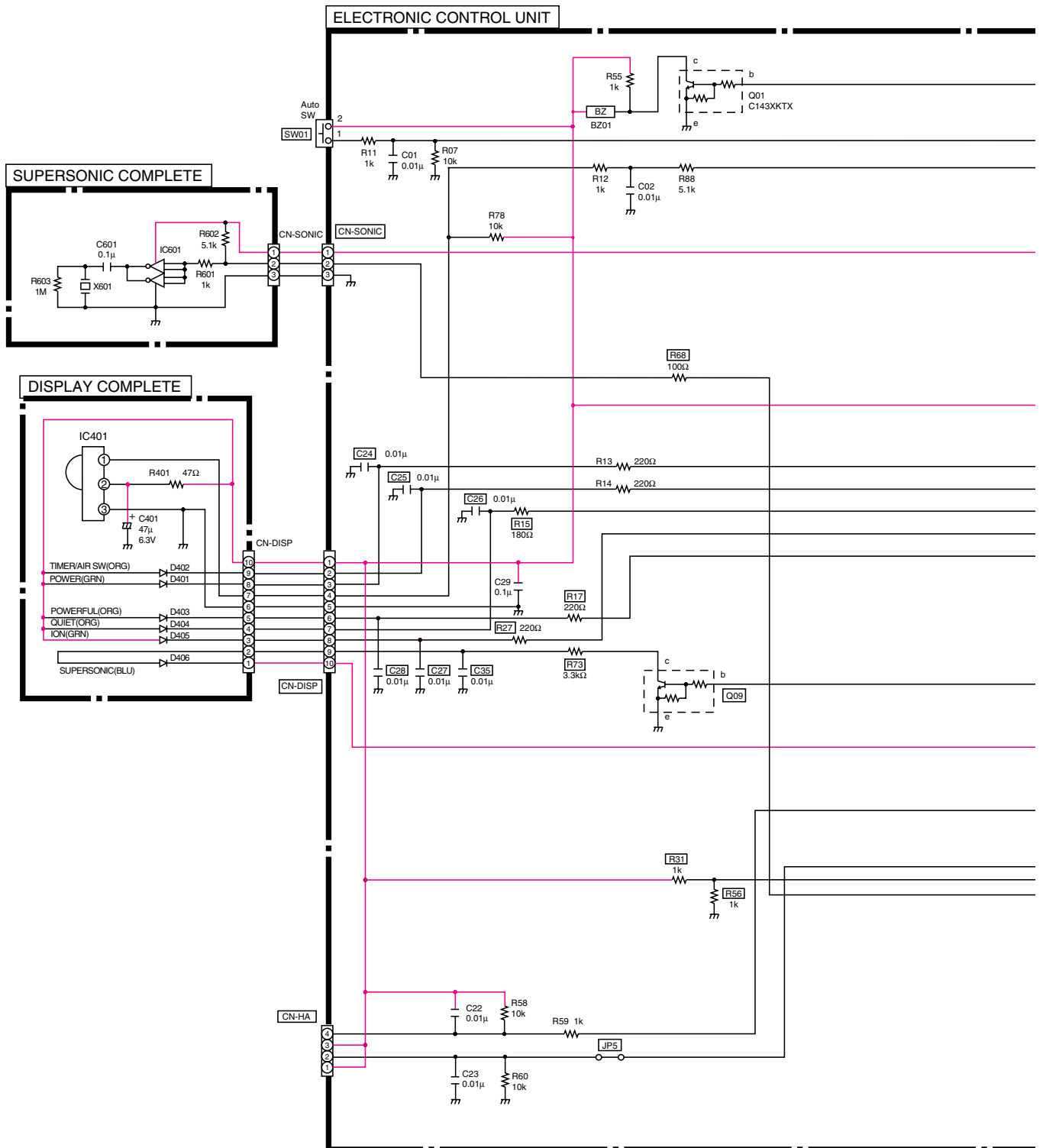

SCHEMATIC DIAGRAM 2/4

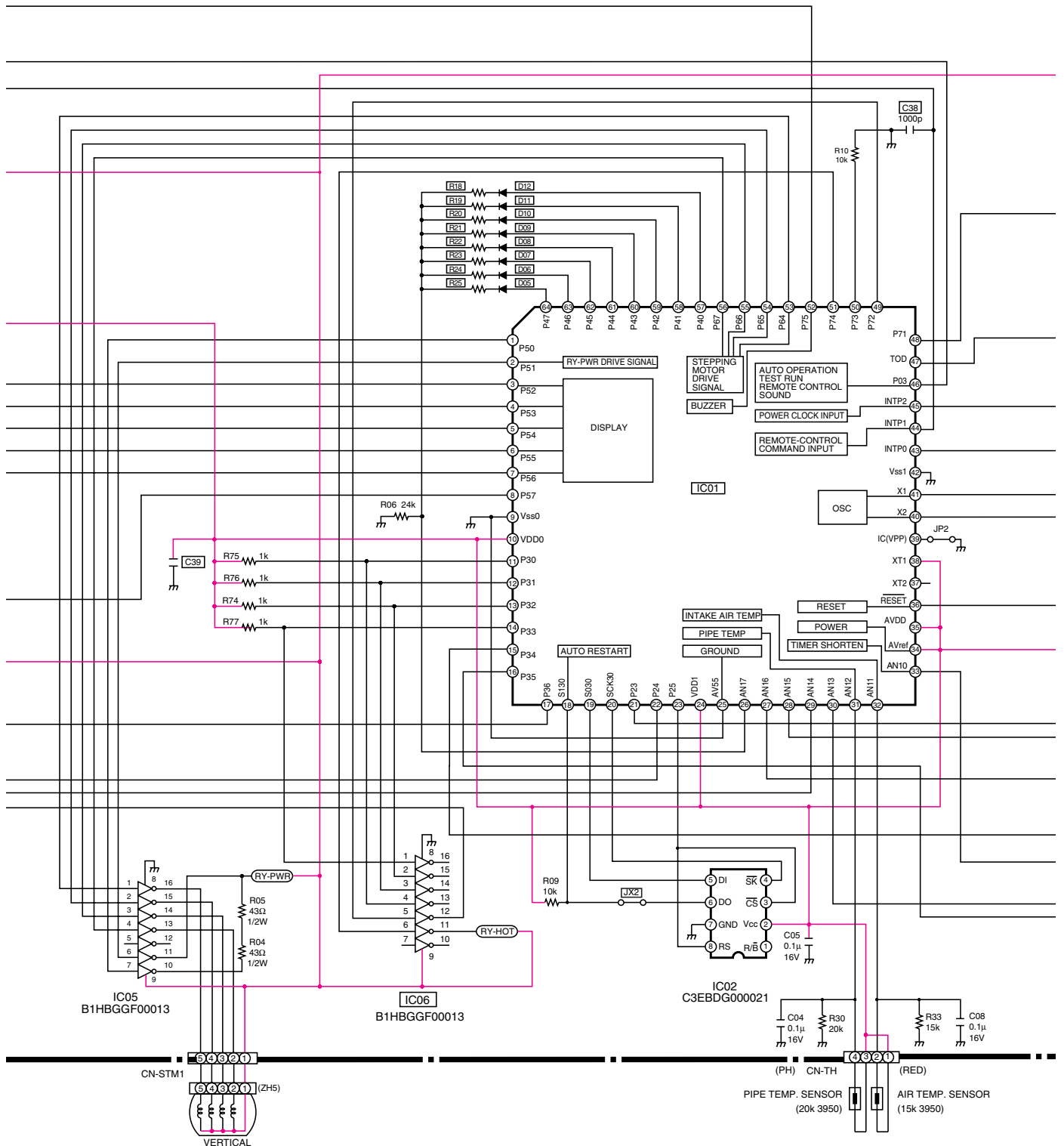



SCHEMATIC DIAGRAM 3/4

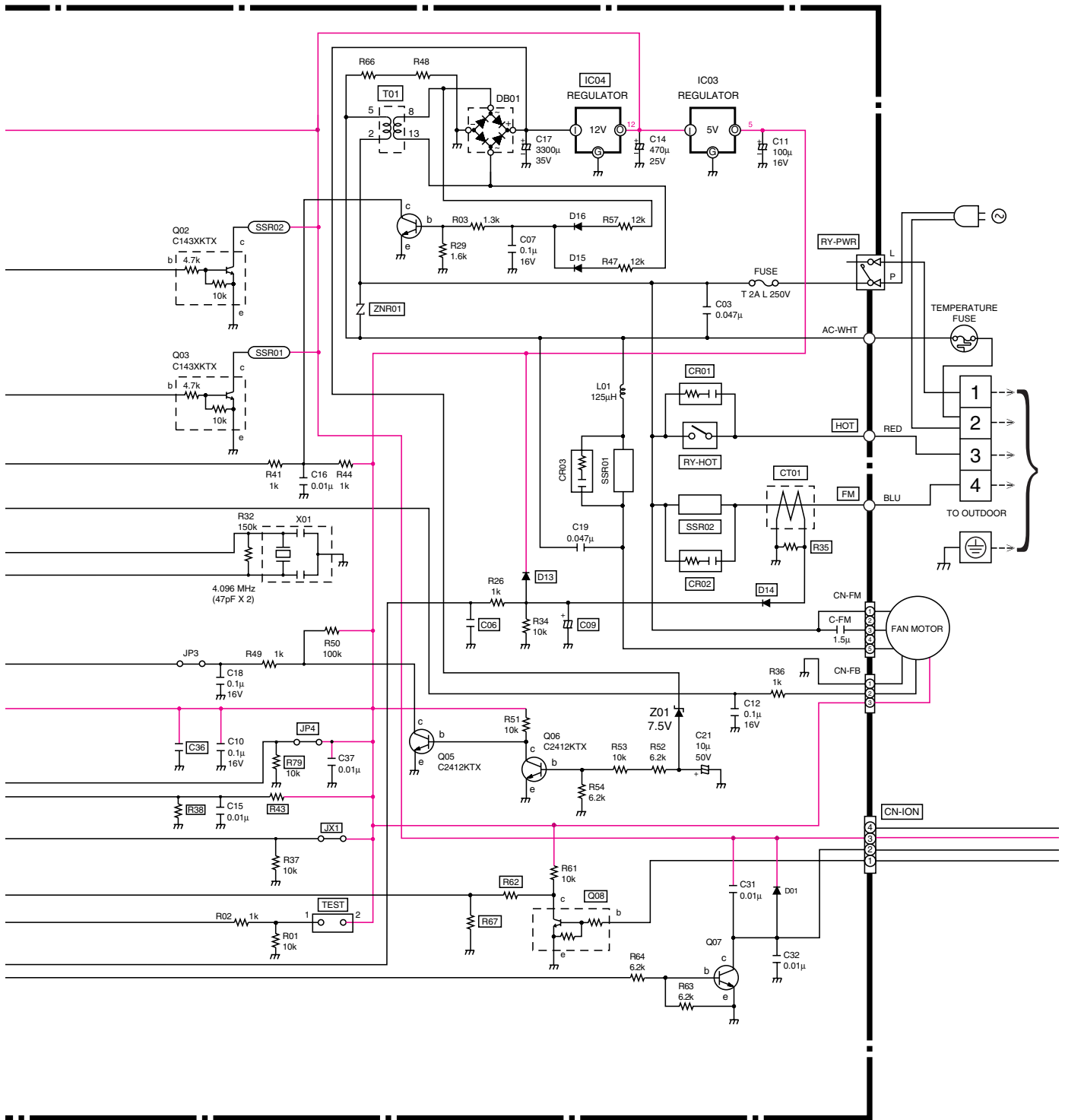

**SCHEMATIC DIAGRAM 4/4**

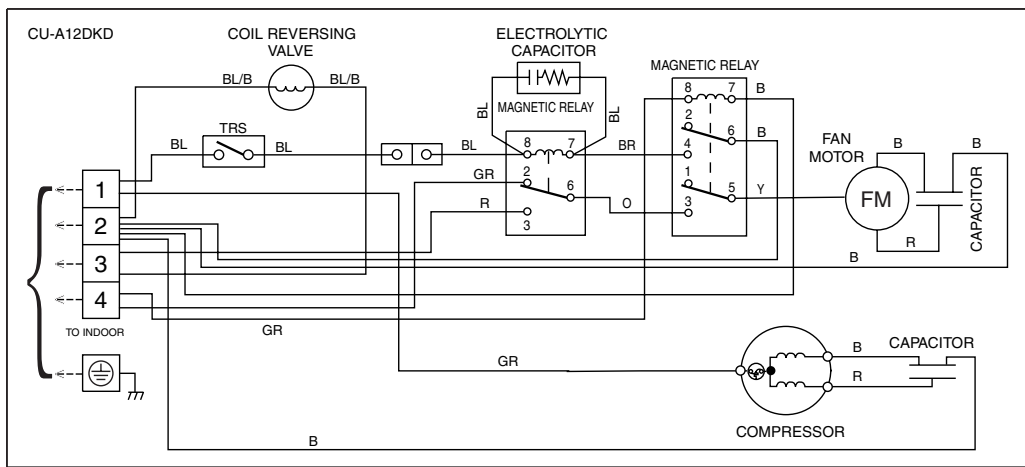
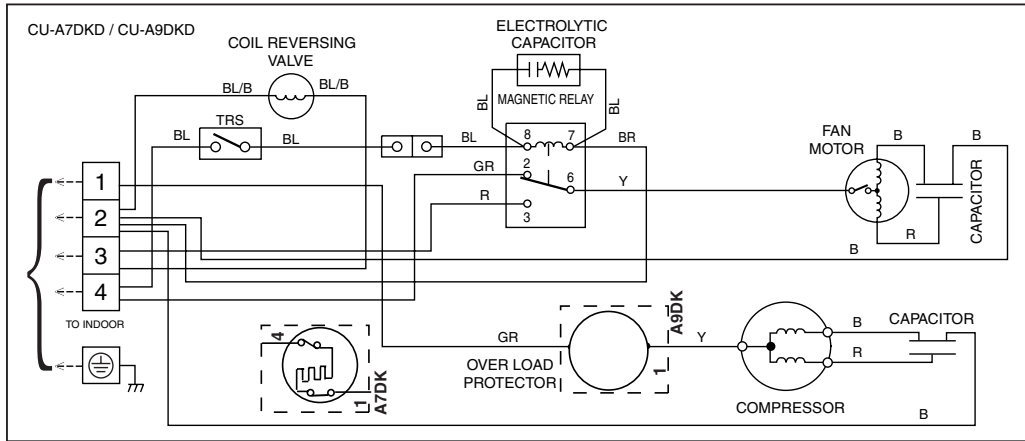

**HIGH VOLTAGE IONIZER**

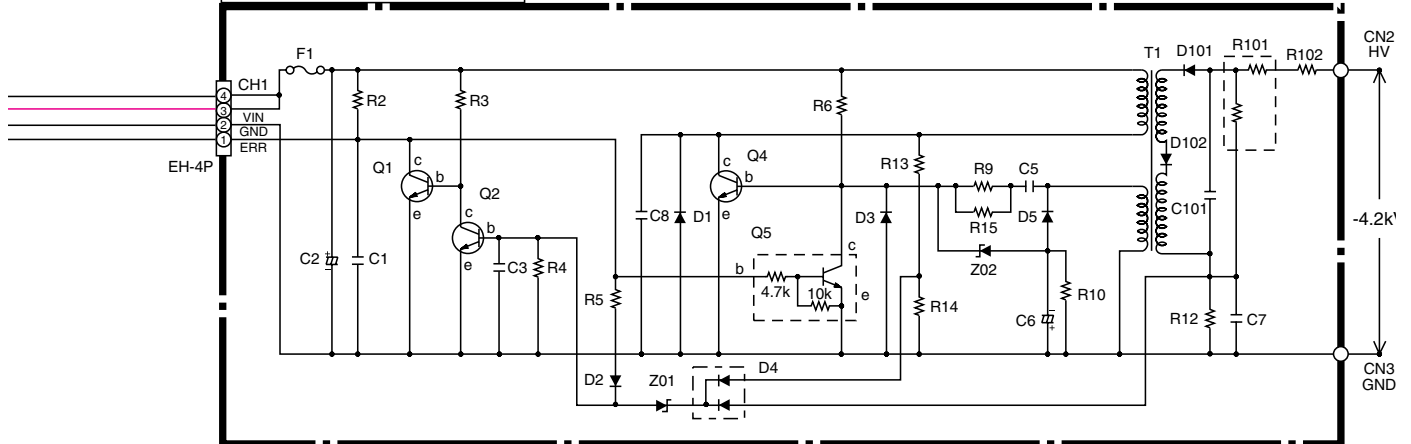

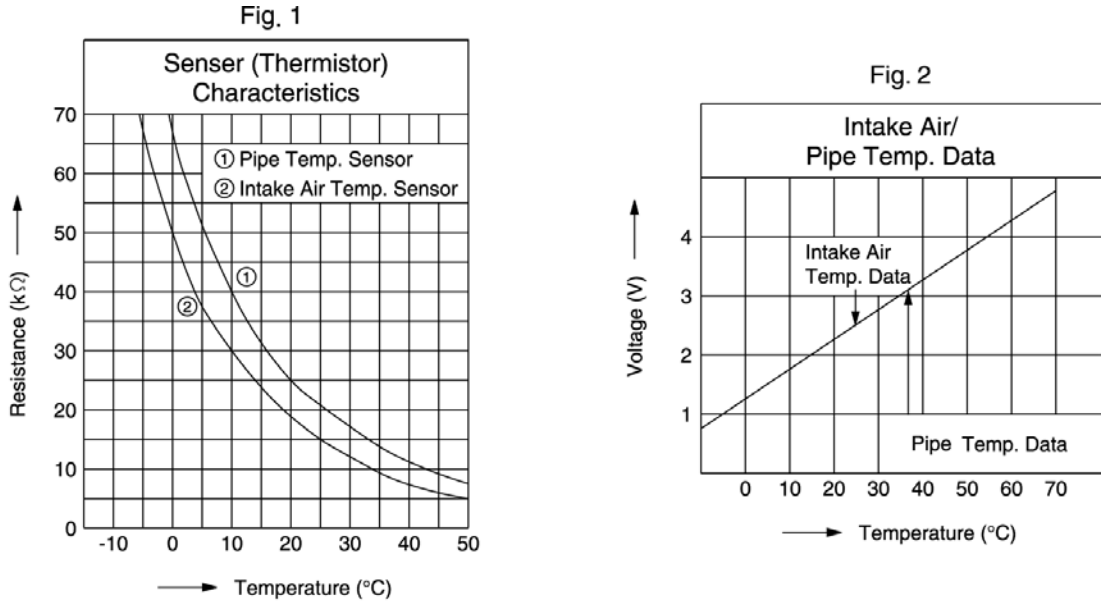
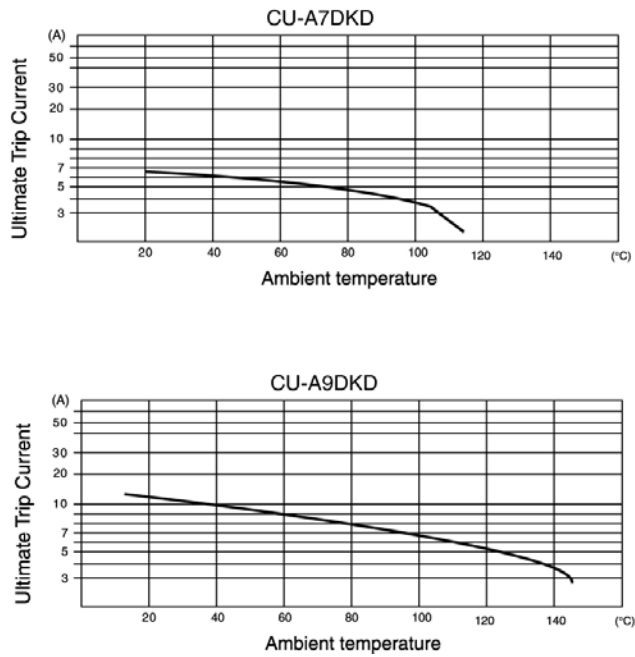

Fig. 3 OLP Characteristics (Compressor)



### How to use electronic circuit diagram

Before using the circuit diagram, read the following carefully.

**\* Voltage measurement**

Voltage has been measured with a digital tester when the indoor fan is set at high fan speed under the following conditions without setting the timer. Use them for servicing.  
Voltage indication is in Red at all operations.

	Intake air temperature	Temperature setting	Discharge air temperature	Pipe temperature
Cooling	27°C	16°C	17°C	15°C
Heating	20°C	30°C	40°C	50°C

**\* Indications for resistance**

a. K...kΩ                      M...MΩ  
W...watt                      Not indicated....1/4W

**b. Type**

Not indicated.....carbon resistor  
Tolerance±5%  
 .....metal oxide resistor  
Tolerance±1%

**\* Indications for capacitor**

a. Unit    μ...μF    P...pF  
b. Type    Not indicated....ceramic capacitor  
(S).....S series aluminium electrolytic capacitor  
(Z).....Z series aluminium electrolytic capacitor  
(SU).....SU series aluminium electrolytic capacitor  
(P).....P series polyester system  
(SXE).....SXE series aluminium electrolytic capacitor  
(SRA).....SRA series aluminium electrolytic capacitor  
(KME).....KME series aluminium electrolytic capacitor

\* Diode without indication.....MA165

※ Circuit Diagram is subject to change without notice for further development.

### TIMER TABLE

Name	Time	Test Mode (When test point Short-circuited)	Remarks
Real Timer	1 hr.	1 min.	
	10 min.	10 sec.	
	1 min.	1 sec.	
Time Delay Safety Control	2 min. 58 sec.	0 sec.	
Forced Operation	60 sec.	0 sec.	
Time Save Control	7 min.	4.2 sec.	
Anti-Freezing	4 min.	0 sec.	
Auto Mode Judgement	25 sec.	0 sec.	
Soft Dry	OFF	6 min.	36 sec.
	ON	10 min.	60 sec.
Deodorizing Control	Cooling	40 sec.	4 sec.
		70 sec.	7 sec.
		20 sec.	2 sec.
		180 sec.	18 sec.
	Soft Dry	40 sec.	4 sec.
		360 sec.	36 sec.
Comp. Reverse Rotation Detection	5 min.	30 sec.	Comp. ON 5 min. and above
	2 min.	0 sec.	
Comp./ Fan Motor Delay Timer	1.6 sec.	0 sec.	
Powerful Mode Operation	15 min.	15 sec.	
Random Auto Restart Control	0 ~ 62 sec.	0 ~ 6.2 sec.	
TRS Recovery Detection	12 min.	72 sec.	
	6 min.	36 sec.	
	3 min.	18 sec.	
	1 min.	6 sec.	
Time Save Control (Heating)	30 min.	3 sec.	
4 Way Valve Control (Delay)	5 min.	30 sec.	
Deice Operation Occurs	60 min.	6 sec.	60 min. after previous deice
	4 min.	24 sec.	Continuously 4 min. Comp. ON
	50 sec.	0 sec.	TRS ON continuously for 50 sec. check
Overload Deice Timer	1 min.	6 sec.	Comp. ON continuously for 1 min. check
Deice End	12 min.	72 sec.	Max. Operation time
	30 sec.	3 sec.	30 sec. Comp. OFF after deice
	10 sec.	1 sec.	4-Way Valve ON 10 sec. later after deice
Deice Operation (Extend)	60 sec.	0 sec.	
	120 sec.	0 sec.	
	180 sec.	0 sec.	
Hotstart Finish	30 sec.	0 sec.	

# 19.2. Remote Control

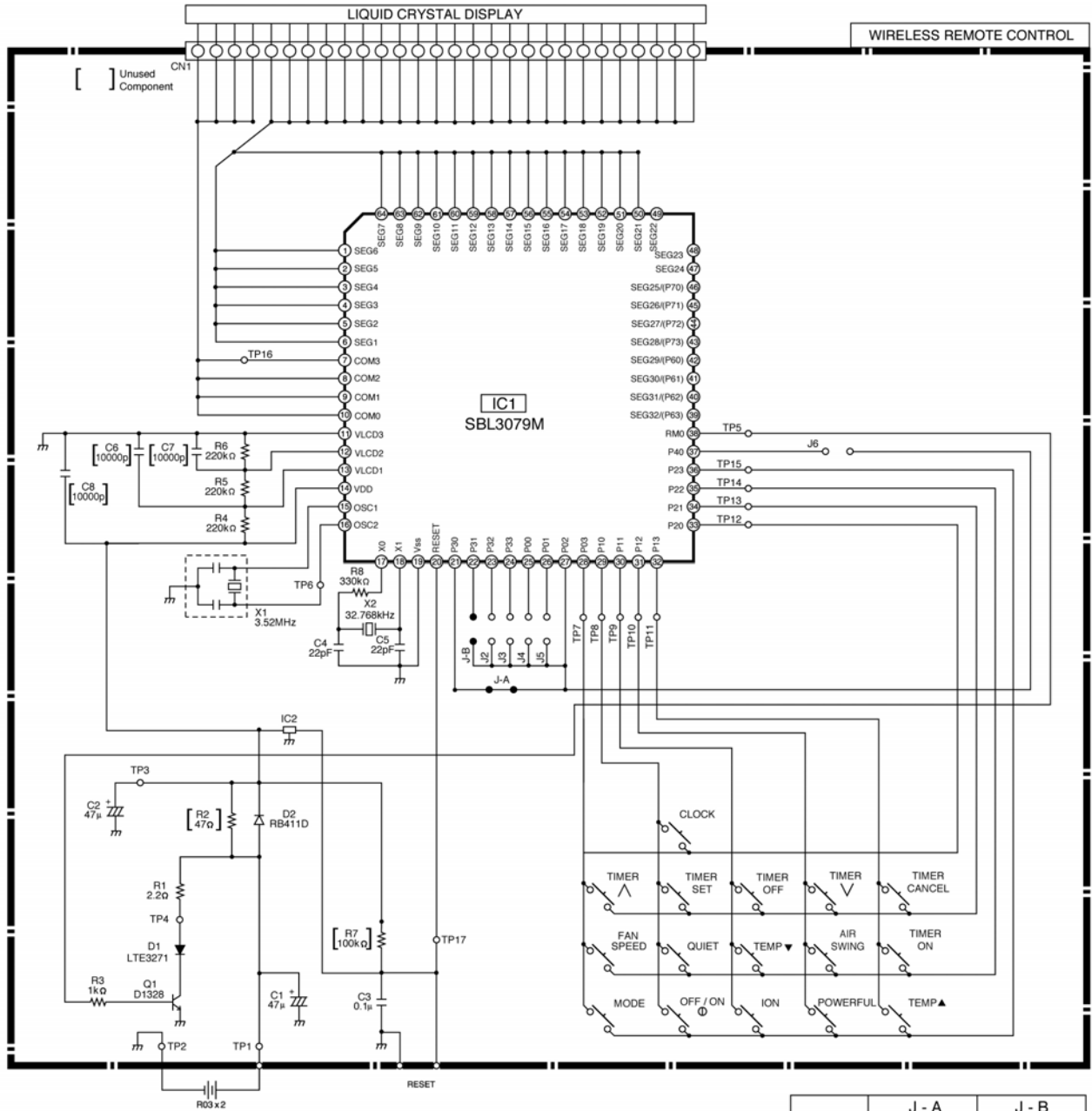

	J - A	J - B
0	SHORT	OPEN
1	OPEN	OPEN
2	SHORT	SHORT
3	OPEN	SHORT





# 19.4. Print Pattern Indicator & Receiver Printed Circuit Board

BOTTOM VIEW

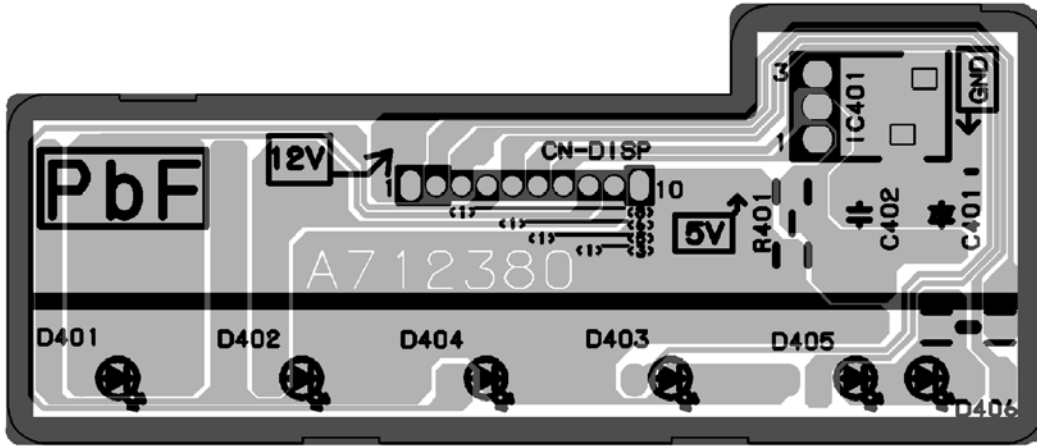

TOP VIEW

