



**SPLIT TYPE
AIR CONDITIONER
CASSETTE type (50Hz)**

**SERVICE
MANUAL**



Models

Indoor unit	Outdoor unit
AUHA36LATN	AOHA36LATL
AUHA45LATN	AOHA45LATL

CONTENTS

SPECIFICATIONS.....	1
DIMENSIONS.....	2
REFRIGERANT SYSTEM DIAGRAM.....	4
CIRCUIT DIAGRAM.....	5
INDOOR PCB CIRCUIT DIAGRAM.....	7
OUTDOOR PCB CIRCUIT DIAGRAM.....	11
ERROR CONTENTS.....	14
PARTS (INDOOR UNIT).....	17
PARTS (OUTDOOR UNIT).....	22
STANDARD ACCESSORIES.....	26

SPECIFICATIONS

TYPE	Cooling & Heating	
INDOOR UNIT	AUHA36LATN	AUHA45LATN
OUTDOOR UNIT	AOHA36LATL	AOHA45LATL
COOLING CAPACITY	10.0 kW	12.5 kW
HEATING CAPACITY	11.2 kW	14.0 kW

ELECTRICAL DATA

POWER SOURCE		230 V 50 Hz	230 V 50 Hz
RUNNING CURRENT	Cooling	13.6 A	17.0 A
	Heating	13.2 A	16.5 A
INPUT WATTS	Cooling	3.11 kW	3.89 kW
	Heating	3.02 kW	3.77 kW
E.E.R.	Cooling	3.21 kW/kW	3.21 kW/kW
	Heating	3.71 kW/kW	3.71 kW/kW
STARTING CURRENT		15 A	15 A
MOISTURE REMOVAL		3.5 L/hr	4.5 L/hr
AIRCIRCULATION INDOOR		1,650 m ³ /hr	1,750 m ³ /hr
AIRCIRCULATION OUTDOOR		6,600 m ³ /hr	6,600 m ³ /hr

FAN MOTOR

INDOOR UNIT	Discrimination	MFF-45RV	MFF-45RV
	High speed	680 r.p.m.	720 r.p.m.
	Med speed	570 r.p.m.	590 r.p.m.
	Low speed	480 r.p.m.	500 r.p.m.
	Quiet (cool/heat)	400/420 r.p.m.	440/440 r.p.m.
OUTDOOR UNIT	Discrimination	MFE-60PO	MFE-60PO
	Upper fan	850 r.p.m.	850 r.p.m.
	Lower fan	750 r.p.m.	750 r.p.m.

NOISE LEVEL

INDOOR UNIT	High speed	50 dB	52 dB
	Med speed	46 dB	47 dB
	Low speed	41 dB	42 dB
	Quiet (cool/heat)	36 dB / 37 dB	39 dB / 39 dB
OUTDOOR UNIT	Cooling	54 dB	55 dB
	Heating	55 dB	56 dB

DIMENSIONS

INDOOR UNIT	H x W x D	296 x 830 x 830 mm
OUTDOOR UNIT	H x W x D	1,290 x 900 x 330 mm

WEIGHT

INDOOR UNIT	Gross / Net	54 kg / 39 kg
OUTDOOR UNIT	Gross / Net	107 kg / 98 kg

COMPRESSOR

TYPE	Hermetic type, Inverter, 4 poles, 3 phase, DC motor, Twin Rotary
DISCRIMINATION	DA420A3F-21ZA
REFRIGERANT R410A	3,350 g

REFRIGERANT CHARGE (R410A)

MAX PIPE LENGTH	50 m	
MAX PIPE HEIGHT	30 m	
FULL CHARGE	Pipe length 20 m	3,350 g
	30 m	3,850 g
	40 m	4,350 g
	50 m	4,850 g
ADDITIONAL CHARGE	50 g/m	

DIMENSIONS

INDOOR UNIT

(Unit : mm)

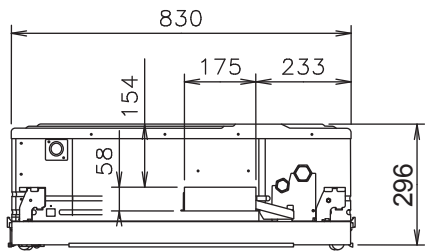

Side view

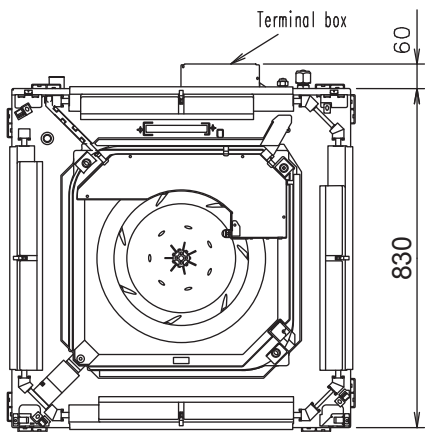

Bottom view

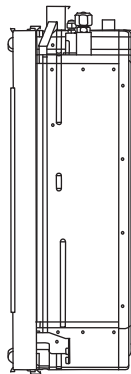

Panel

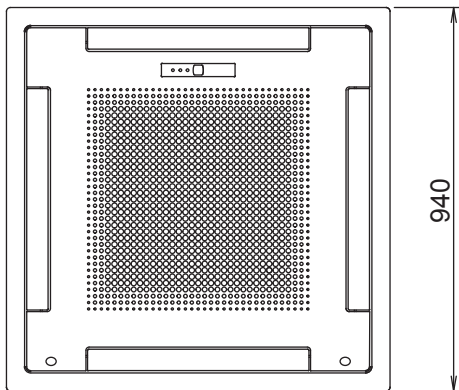

Bottom view

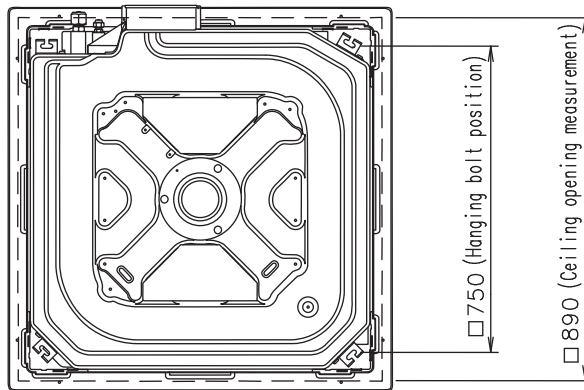

Top view

Selection of setting

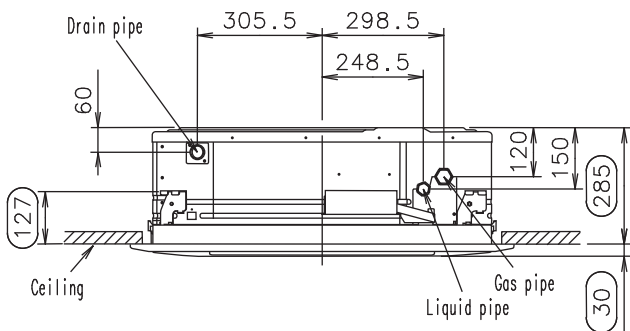

Side view (Standard setting)

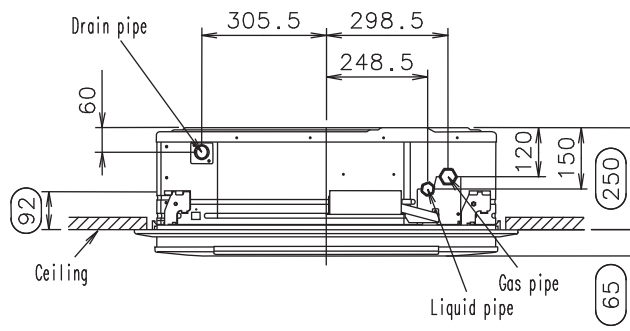

Side view (Slender setting)

OUTDOOR UNIT

(Unit : mm)

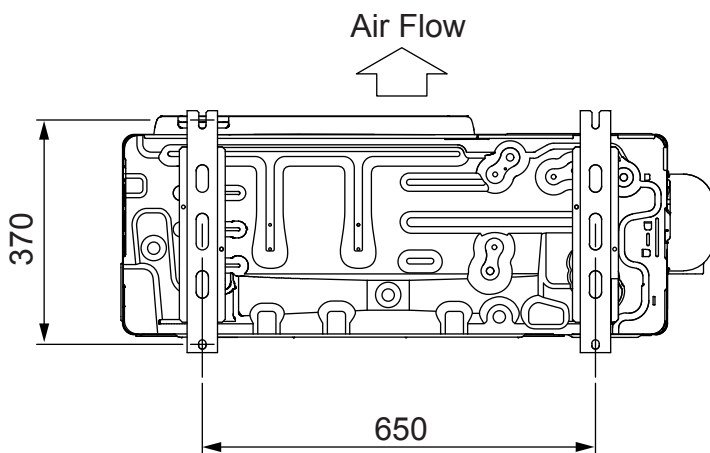
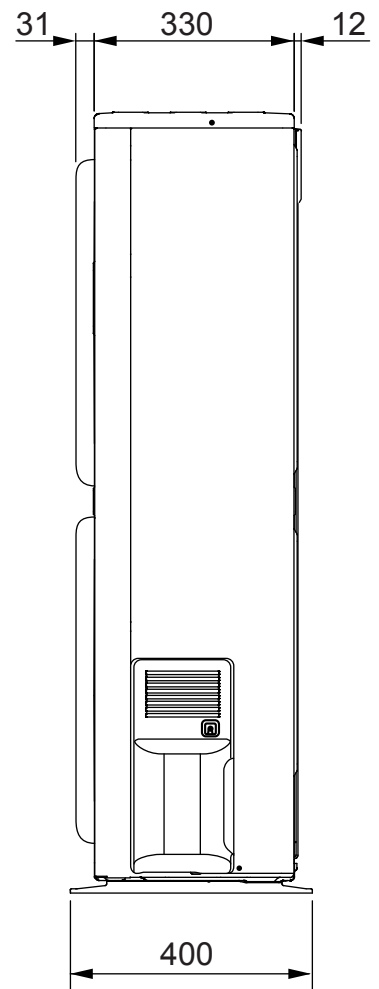
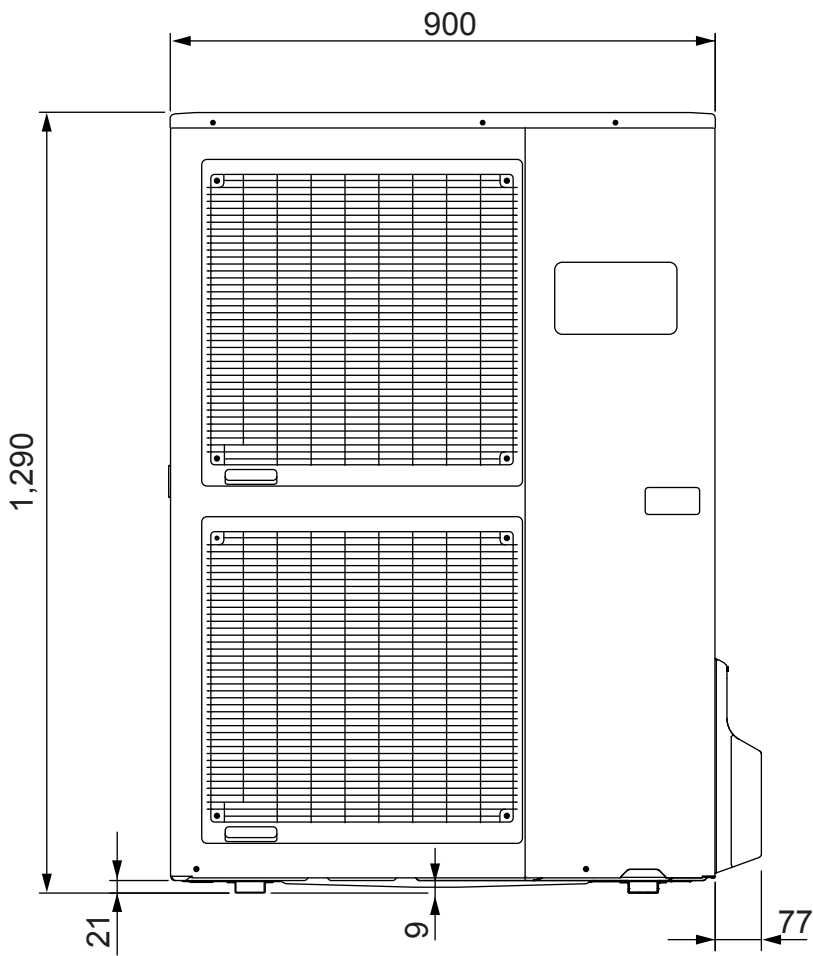
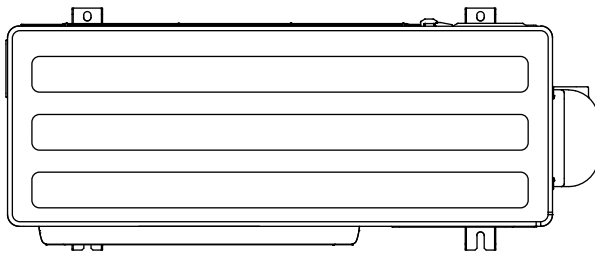

REFRIGERANT SYSTEM DIAGRAM

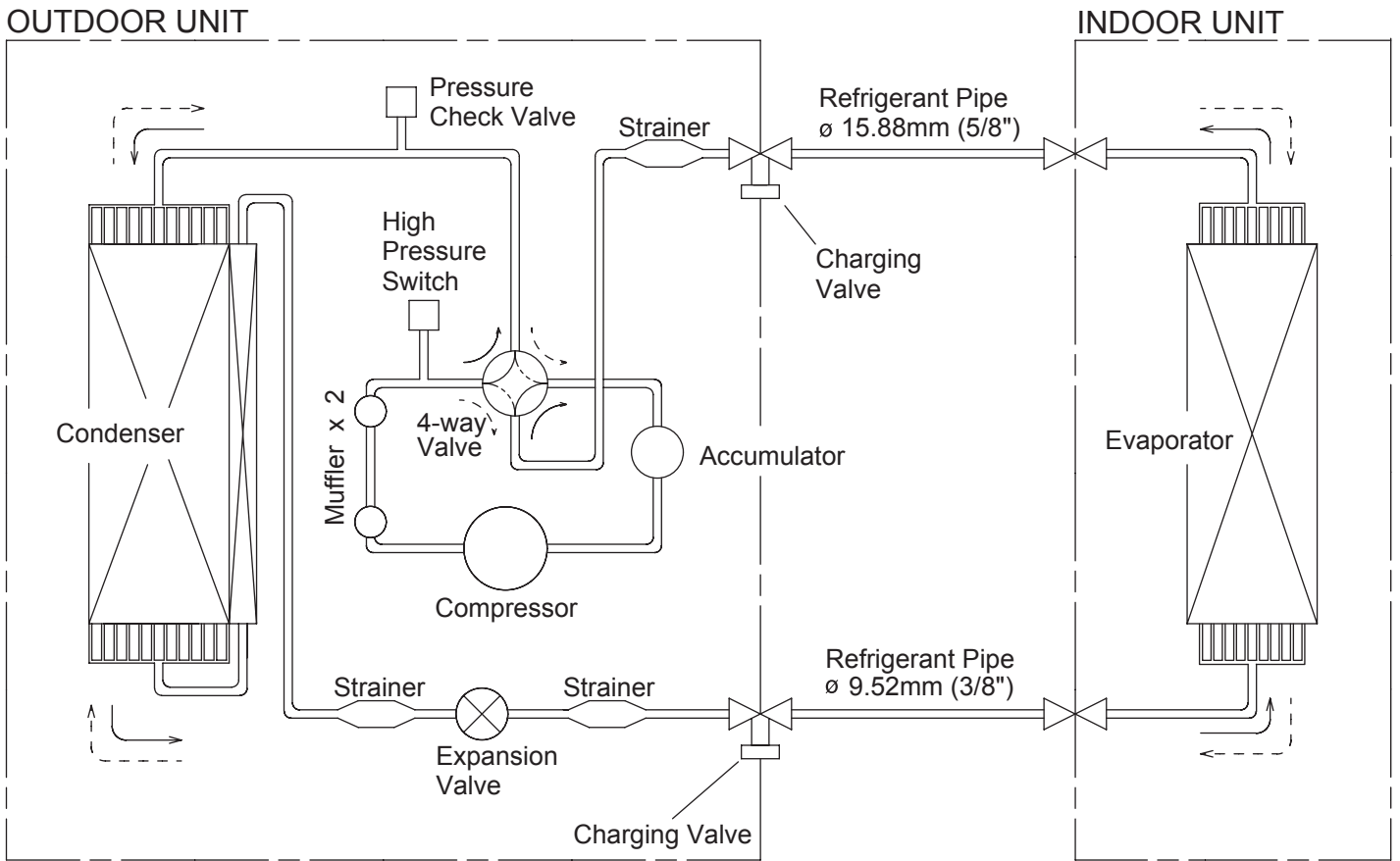

Refrigerant direction

→ : Cool

- - -> : Heat

CIRCUIT DIAGRAM

INDOOR UNIT

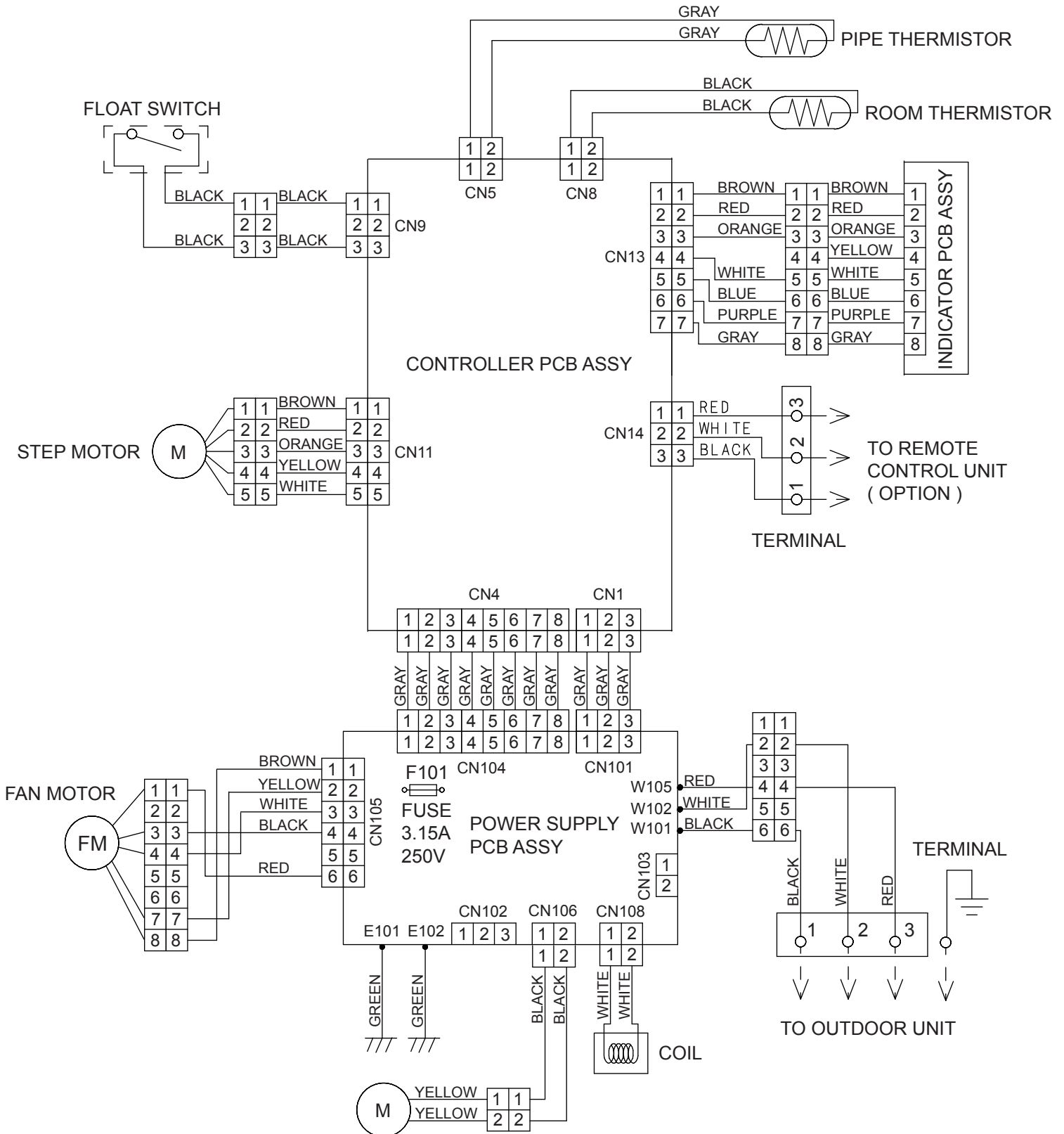

OUTDOOR UNIT

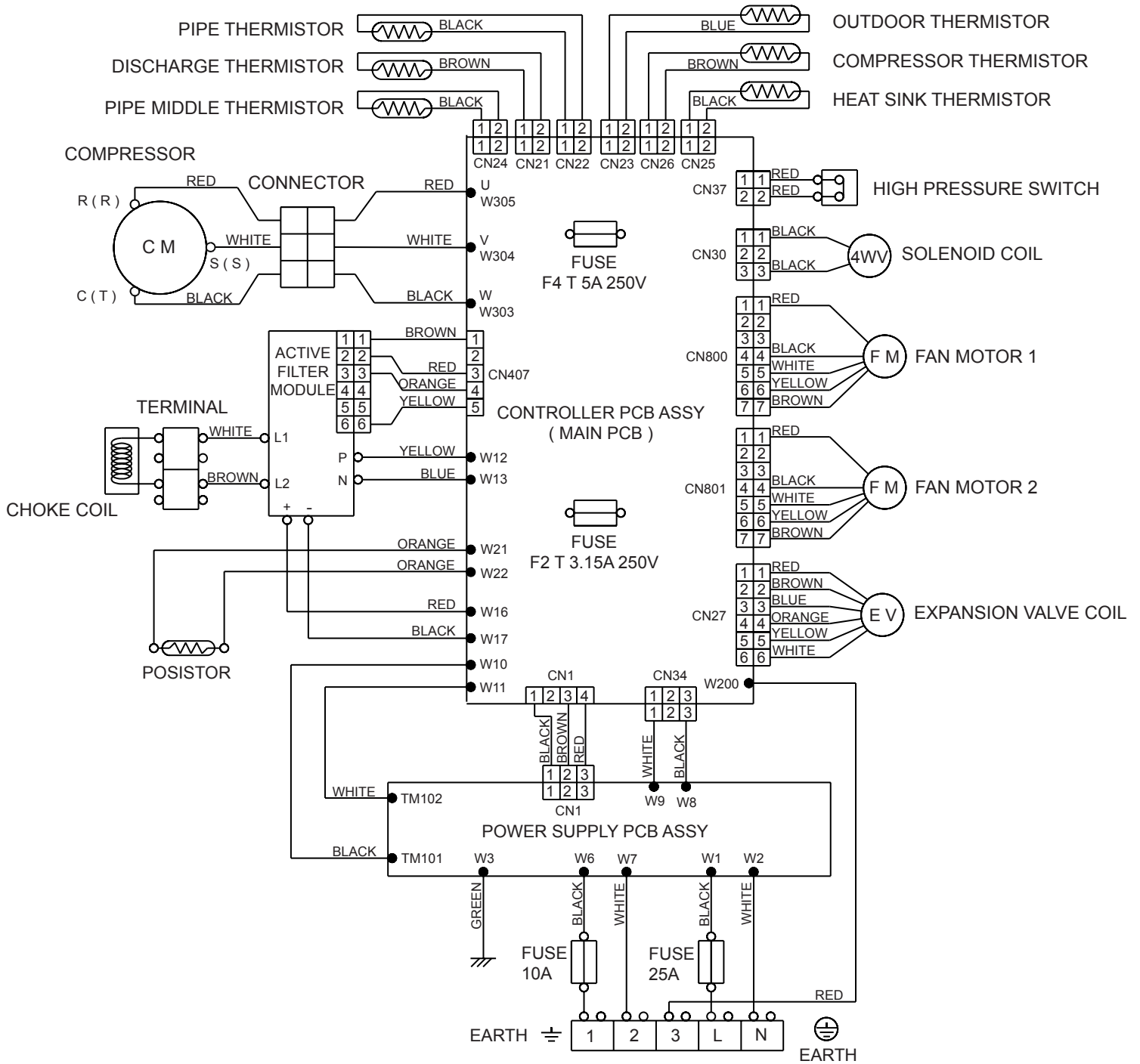

INDOOR PCB CIRCUIT DIAGRAM

CONTROL UNIT
 AUHA36LATN : EZ-0061KHSE
 AUHA45LATN : EZ-0061HHSE

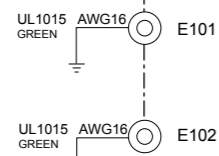
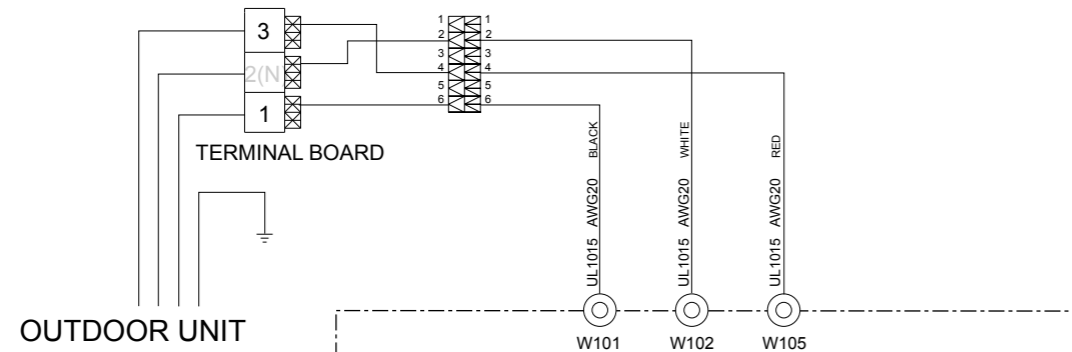

POWER SUPPLY PCB ASSEMBLY
 K06AL-0604HSE-P0

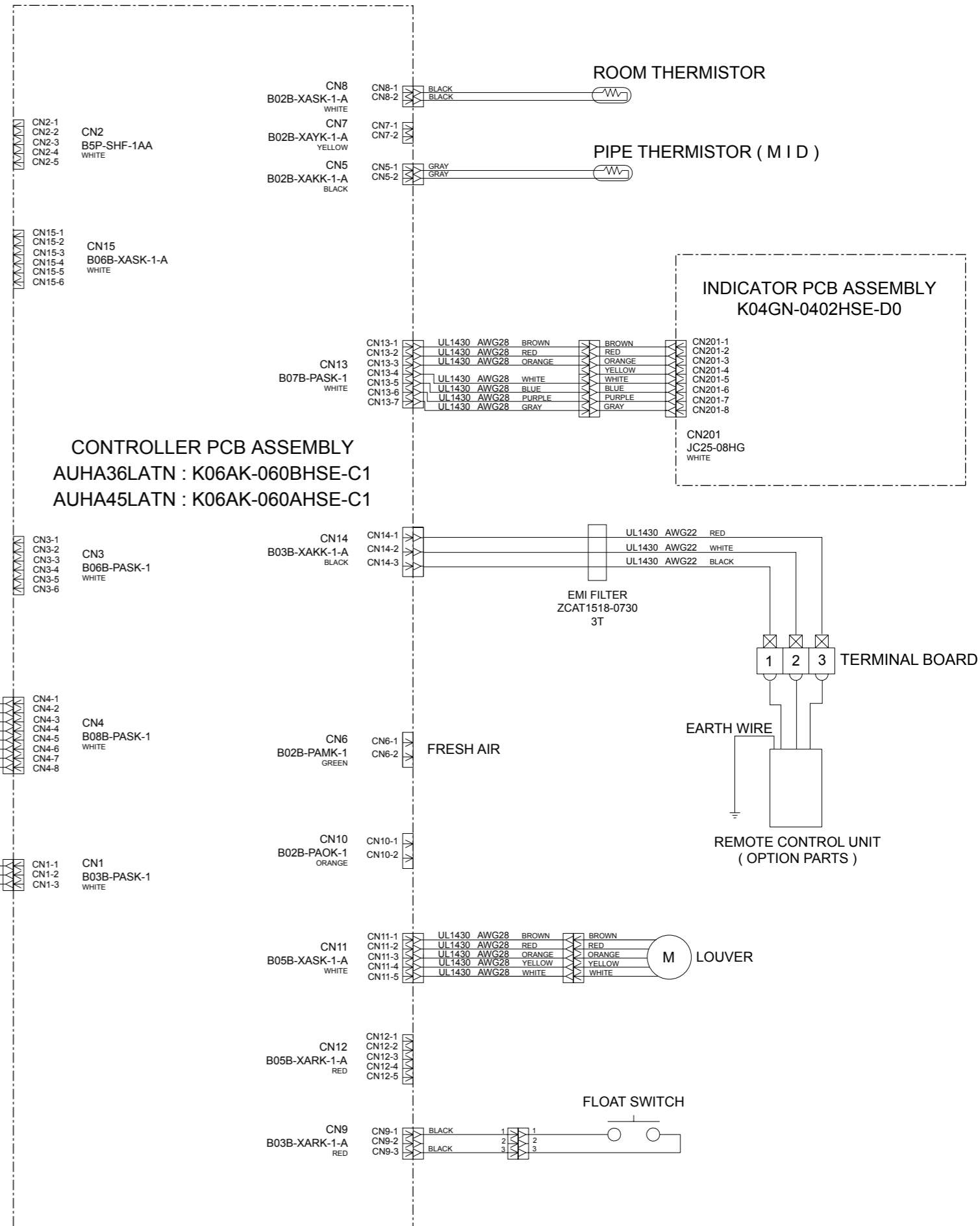
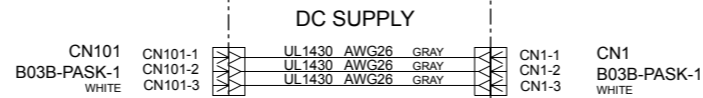
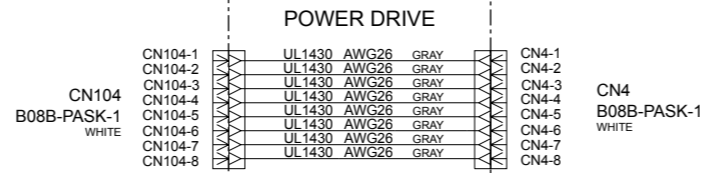
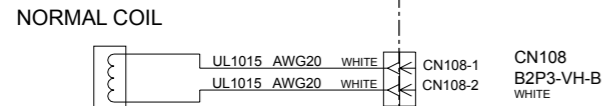
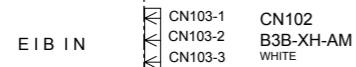
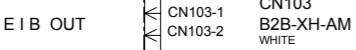
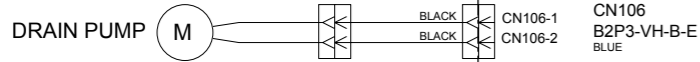
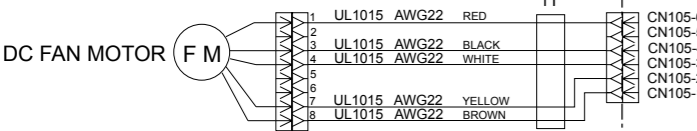

CONTROLLER PCB ASSEMBLY
 AUHA36LATN : K06AK-060BHSE-C1
 AUHA45LATN : K06AK-060AHSE-C1

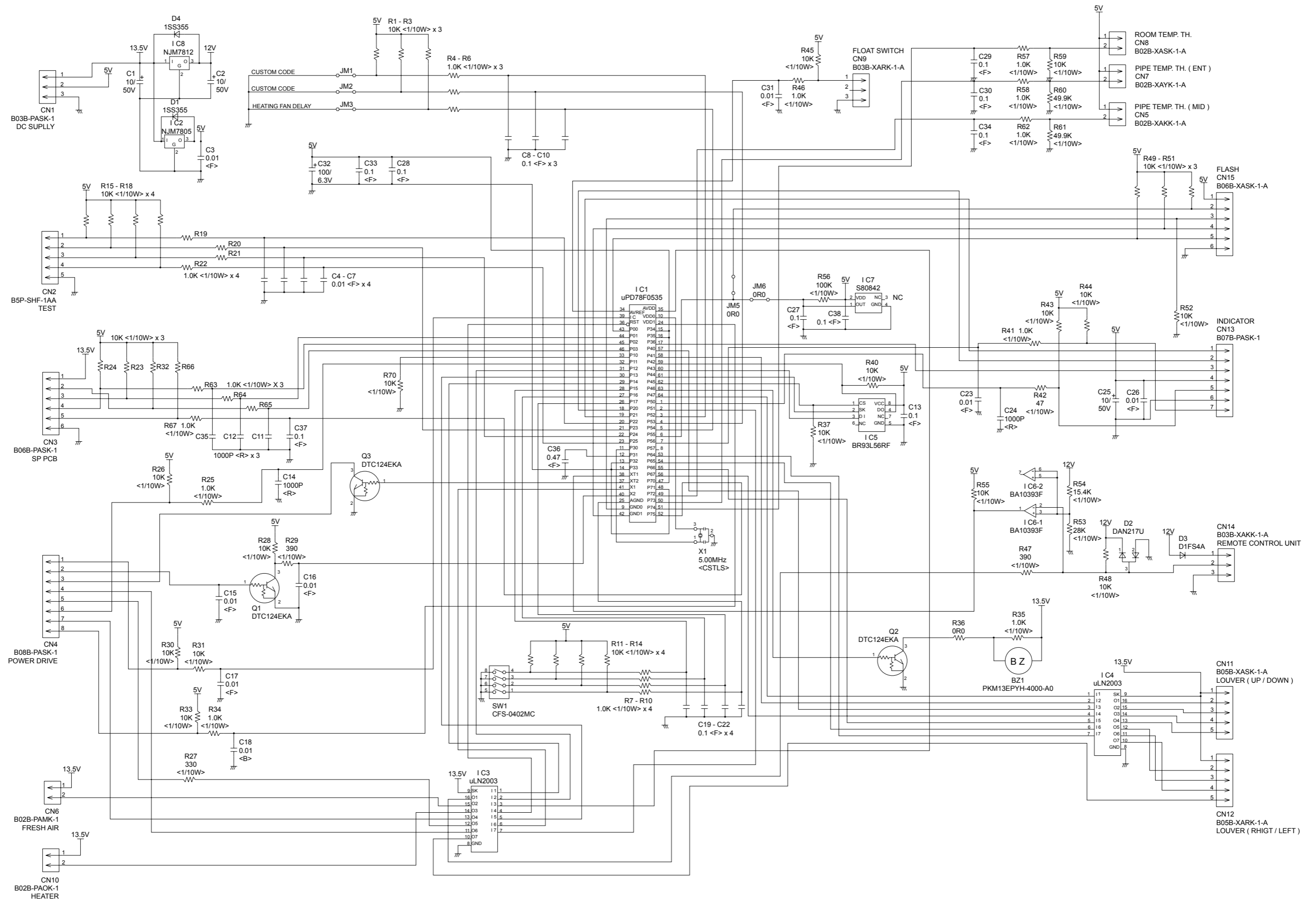

INDOOR UNIT

POWER SUPPLY PCB ASSEMBLY
K06AL-0604HSE-P0

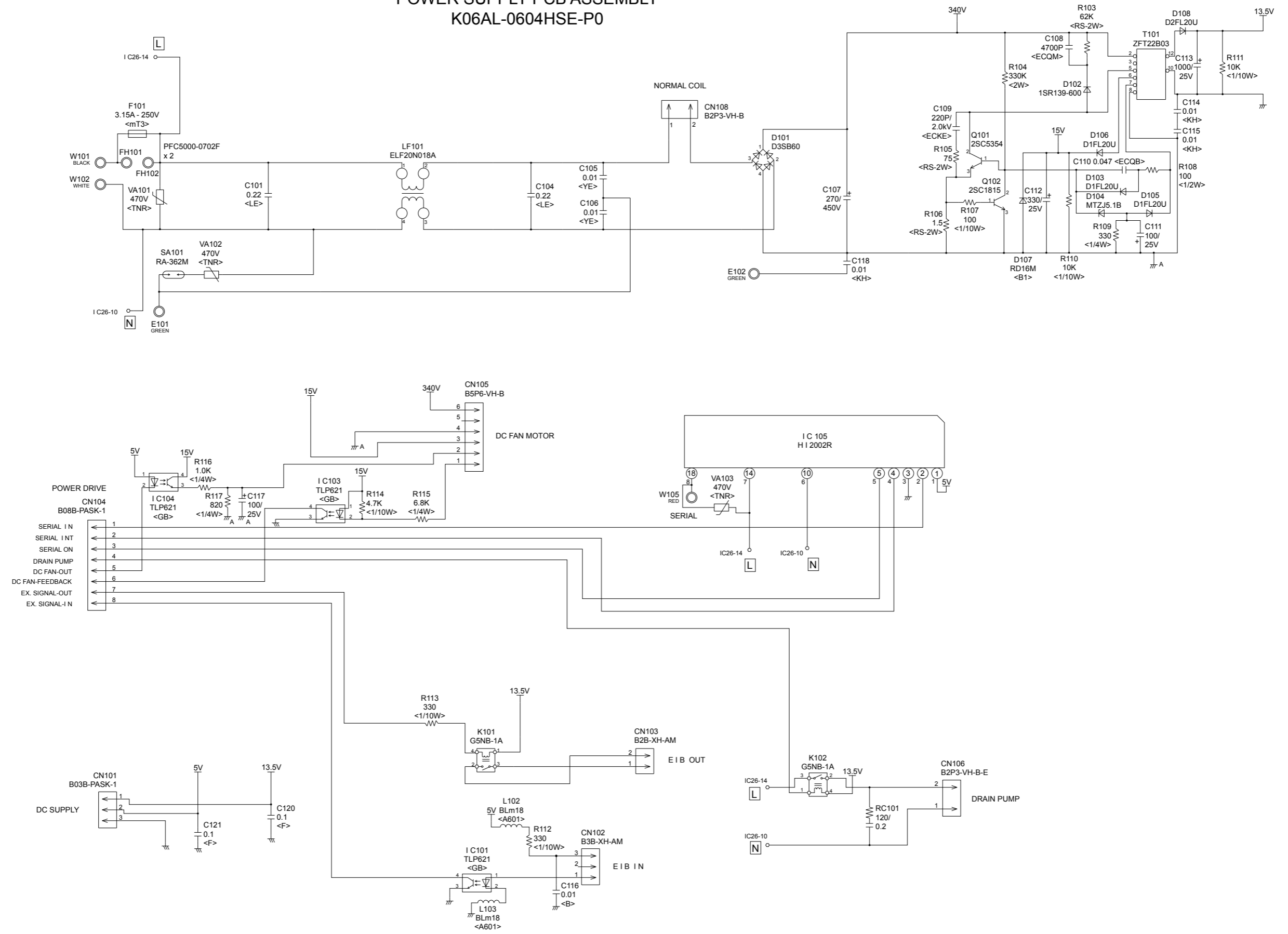

INDOOR UNIT

INDICATOR PCB ASSEMBLY
K04GN-0402HSE-D0

TO CONTROLLER PCB ASSEMBLY

- (OPERATE) BROWN
- (TIMER) RED
- (LOUVER) ORANGE
- (LOUVER) YELLOW
- (5V) WHITE
- (REMOTE CONTROL) BLUE
- (GND) PURPLE
- (MANUAL AUTO SWITCH) GRAY

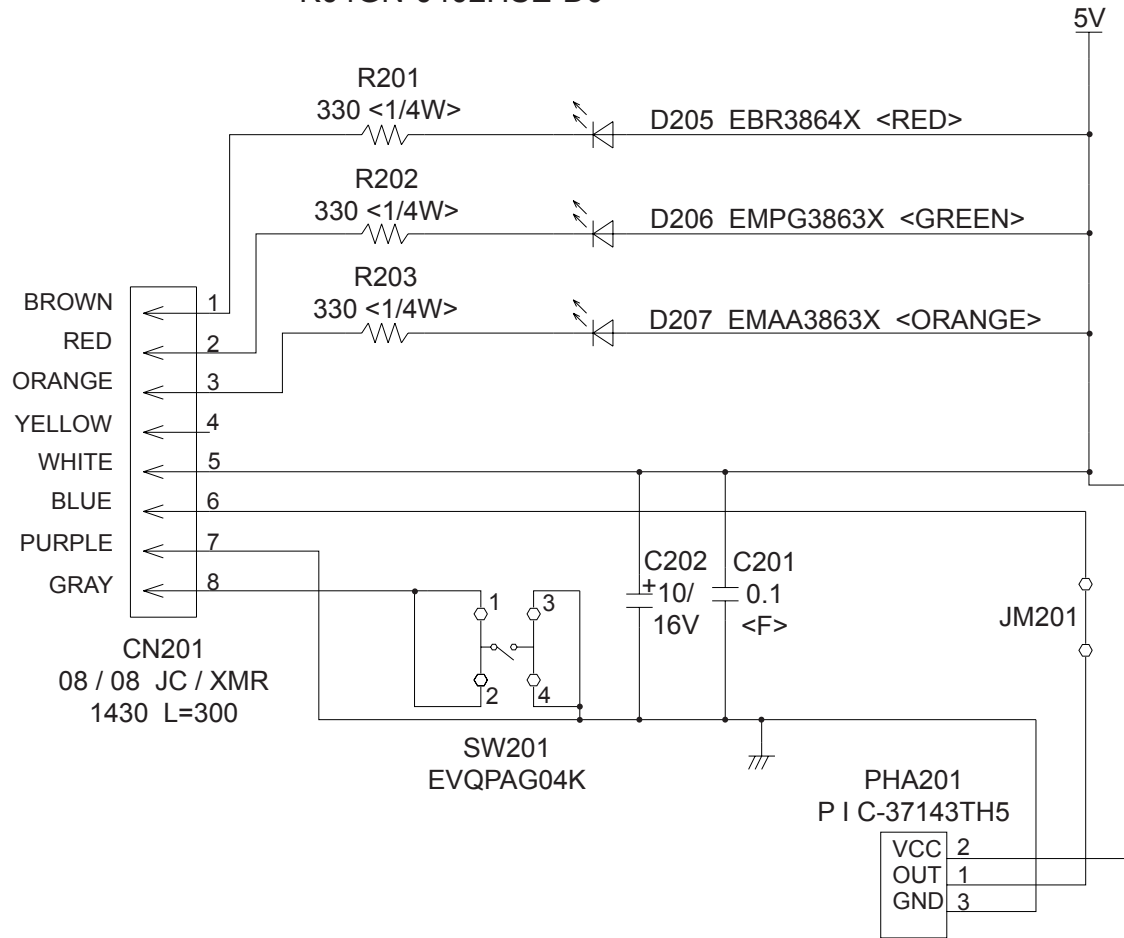

OUTDOOR PCB CIRCUIT DIAGRAM

INVERTER ASSEMBLY

AOHA36LATL : EZ-00603HUE

AOHA45LATL : EZ-00604HUE

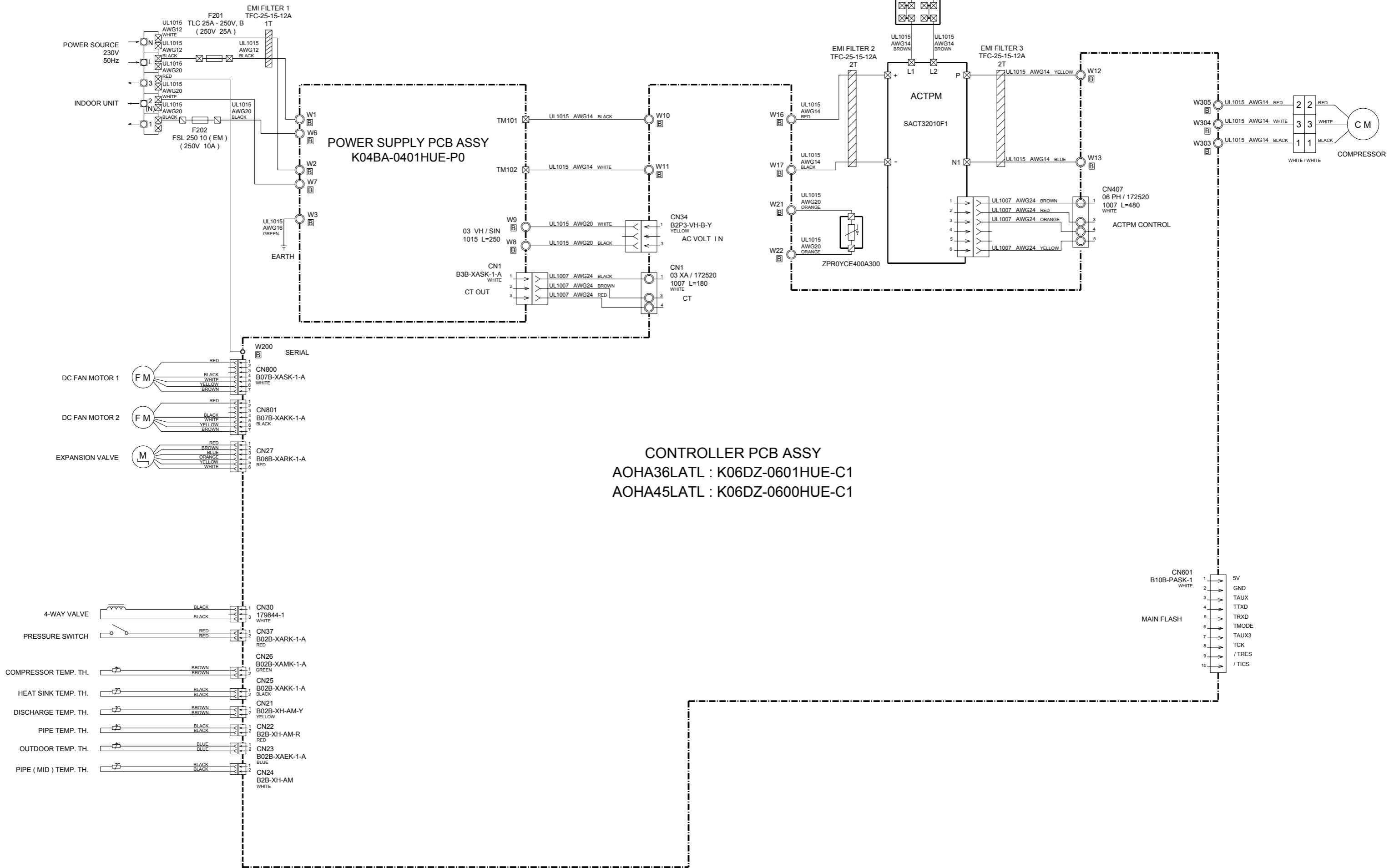

CONTROLLER PCB ASSEMBLY
 AOHA36LATL : K06DZ-0601HUE-C1
 AOHA45LATL : K06DZ-0600HUE-C1

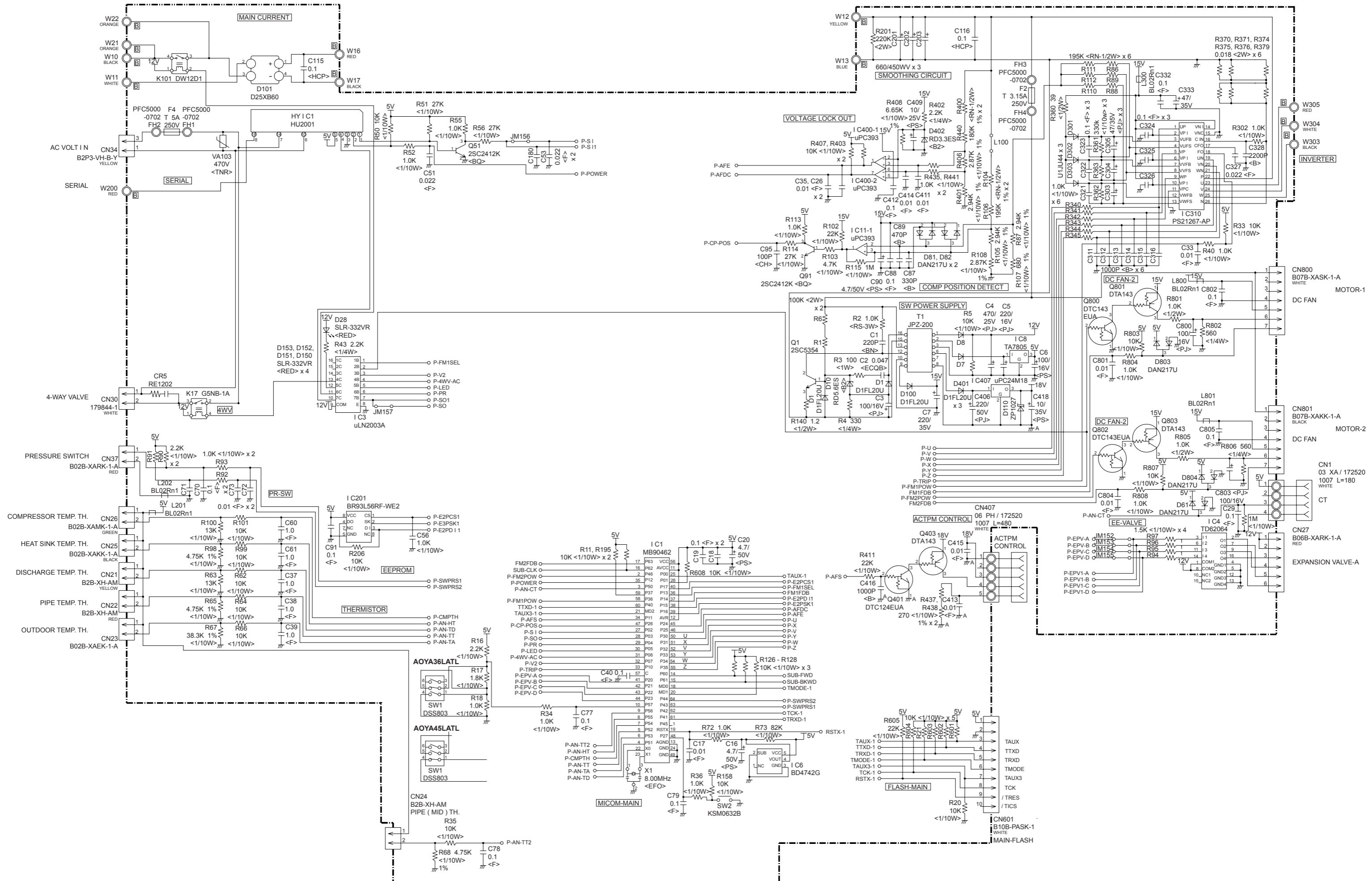

OUTDOOR UNIT
 POWER SUPPLY PCB ASSEMBLY
 K04BA-0401HUE-P0

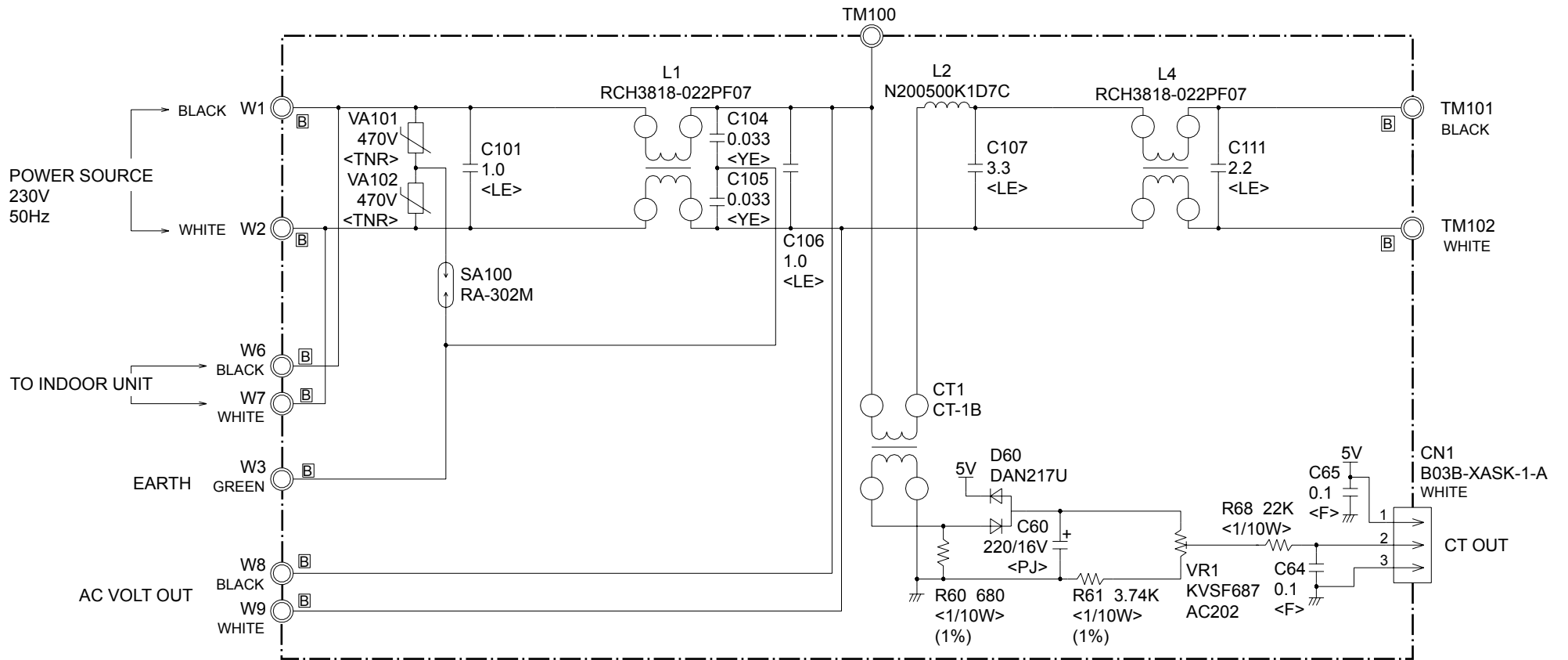

ERROR CONTENTS

INDOOR UNIT

TROUBLESHOOTING

Troubleshooting with the indoor display

Troubleshooting at the display is possible either on the wired or wireless remote control.

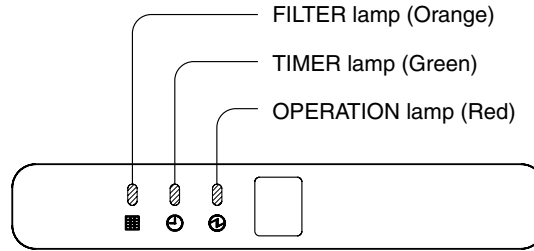

The OPERATION, TIMER and FILTER lamp operate as follows table according to the error contents.

Error contents	OPERATION lamp (RED)	TIMER lamp (GREEN)	FILTER lamp (ORANGE)
Indoor signal error	×	○	×
Wired remote controller abnormal	×	(8 times) ○	×
Indoor room temperature sensor error	(2 times) ○	(2 times) ○	×
Indoor heat exchanger temperature sensor (middle) error	(2 times) ○	(3 times) ○	×
Indoor heat exchanger temperature sensor (inlet) error	(2 times) ○	(4 times) ○	×
Float switch operated	(2 times) ○	(6 times) ○	×
Outdoor discharge pipe temperature sensor error	(3 times) ○	(2 times) ○	×
Outdoor heat exchanger temperature sensor (outlet) error	(3 times) ○	(3 times) ○	×
Outdoor temperature sensor error	(3 times) ○	(4 times) ○	×
Heatsink sensor error	(3 times) ○	(7 times) ○	×
Compressor temperature sensor error	(3 times) ○	(8 times) ○	×
2-way valve temperature sensor error	(3 times) ○	×	(2 times) ○
3-way valve temperature sensor error	(3 times) ○	×	(3 times) ○
Outdoor heat exchanger temperature sensor (middle) error	(3 times) ○	×	(4 times) ○
Indoor manual auto switch abnormal	(4 times) ○	(2 times) ○	×
Power supply frequency detection error	(4 times) ○	(4 times) ○	×
IPM protection	(5 times) ○	(2 times) ○	×
CT error	(5 times) ○	(3 times) ○	×
Compressor location error	(5 times) ○	(5 times) ○	×
Outdoor fan error	(5 times) ○	(6 times) ○	×
Connected indoor unit abnormal	(5 times) ○	(7 times) ○	×
Outdoor unit computer communication error	(5 times) ○	(8 times) ○	×
Indoor fan abnormal	(6 times) ○	(2 or 3 times) ○	×
Discharge temperature error	(7 times) ○	(2 times) ○	×
Excessive high pressure protection on cooling	(7 times) ○	(3 times) ○	×
4-way valve abnormal	(7 times) ○	(4 times) ○	×
Pressure switch abnormal	(7 times) ○	(5 times) ○	×
Compressor temperature error	(7 times) ○	(6 times) ○	×
Active filter abnormal	(8 times) ○	(2 or 3 times) ○	×
PFC circuit error	(8 times) ○	(4 times) ○	×

○: 0.5s ON/0.5s OFF (Flash) ×: OFF

ERROR CONTENTS

REMOTE CONTROL UNIT

Troubleshooting at the remote control LCD

This is possible only on the wired remote control.

If an error occurs, the following display will be shown.
("EE" will appear in the set room temperature display.)

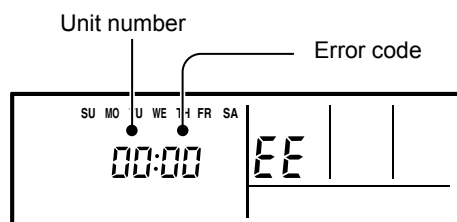

Code	Error contents
01 13 26 27	Indoor signal error
00	Wired remote controller abnormal
02	Indoor room temperature sensor error
04	Indoor heat exchanger temperature sensor (middle) error
28	Indoor heat exchanger temperature sensor (inlet) error
09	Float switch operated
0C	Outdoor discharge pipe temperature sensor error
06	Outdoor heat exchanger temperature sensor (outlet) error
0A	Outdoor temperature sensor error
0E	Heatsink sensor error
15	Compressor temperature sensor error
1d	2-way valve temperature sensor error
1E	3-way valve temperature sensor error
29	Outdoor heat exchanger temperature sensor (middle) error
20	Indoor manual auto switch abnormal
2A	Power supply frequency detection error
17	IPM protection
18	CT error
1A	Compressor location error
1b	Outdoor fan error
1F	Connected indoor unit abnormal
1c	Outdoor unit computer communication error
12	Indoor fan abnormal
0F	Discharge temperature error
24	Excessive high pressure protection on cooling
2c	4-way valve abnormal
16	Pressure switch abnormal
2b	Compressor temperature error
19	Active filter abnormal
25	PFC circuit error

If "CO" appears in the unit number display, there is a remote control error. Refer to the installation instruction sheet included with the remote control.

OUTDOOR UNIT LEDS

Make a TEST RUN in accordance with the installation instruction sheet for the indoor unit.

When a malfunction occurs in the outdoor unit, the LED on the circuit board lights to indicate the error. Refer to the following table for the description of each error according to the LED.

LED	Error contents
1 flash	Communication error (Indoor unit - Outdoor unit)
2 flash	Discharge pipe temperature sensor
3 flash	Outdoor heat exchanger temperature (outlet) sensor
4 flash	Outdoor temperature sensor
5 flash	Outdoor heat exchanger temperature (mid) sensor
6 flash	Discharge pipe temperature abnormal
7 flash	Compressor temperature sensor
8 flash	Heat sink temperature sensor
9 flash	Pressure switch abnormal
10 flash	Compressor temperature abnormal
12 flash	IPM error
13 flash	Compressor rotor position cannot detect
14 flash	Compressor cannot operate
15 flash	Outdoor fan abnormal (upper fan)
16 flash	Outdoor fan abnormal (lower fan)
5 sec. on/ 1 sec. off repeat	Protect operation
1 sec. on/ 1 sec. off repeat	Pump down operation
off	No error

SPECIAL INSTALLATION SETTING

PUMP DOWN (Refrigerant collecting operation)

Perform the following procedures to collect the refrigerant when moving the indoor unit or outdoor unit

1. When the product is stopped:

①	Press the PUMP DOWN switch on the outdoor unit. (The LED on the outdoor unit circuit board starts flashing.) (1 sec. on / 1 sec. off repeated)
②	The pump down operation (cooling operation) begins right away. After operation starts, close the three-way valve (liquid).
③	After 2 - 3 minutes, operation stops. Close the three-way valve (gas) within one minute after operations stops.
④	The LED will go out three minutes after it stops. Disconnect the power supply after confirming that the LED has gone out.

2. When the product is operating:

①	Press the PUMP DOWN switch on the outdoor unit. The LED on the outdoor unit circuit board starts flashing (1 sec. on / 1 sec. off repeated), and operation stops. At this point, recovery has not been completed, so do not close the three-way valves. (liquid and gas)
②	The pump down operation (cooling operation) begins after three minutes. Close the three-way valve (liquid) after operation starts.
③	After 2 - 3 minutes, operation stops. Close the three-way valve (gas) within one minute after operations stops.
④	The LED will go out three minutes after it stops. Disconnect the power supply after confirming that the LED has gone out.

*When the pump down operation is repeated, temporarily disconnect the power supply after opening the closed valves (both liquid and gas). Reconnect the power supply after 2 - 3 minutes and perform the pump down operation.

*When the start of the operation after pump down operation has been completed, temporarily disconnect the power supply after opening the closed valves (both liquid and gas). Reconnect the power supply after 2-3 minutes and be sure to perform a test operation for cooling.

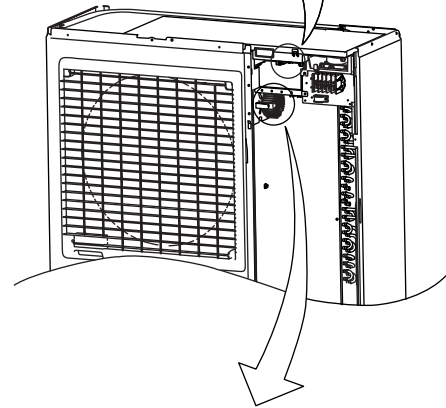
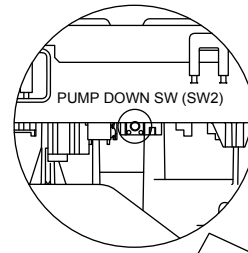

⚠ DANGER
This part (Choke coil) generates high voltages. Never touch this part.

		Tightening torque
Blank cap	6.35 mm (1/4 in.)	20 to 25 N-m (200 to 250 kgf-cm)
	9.52 mm (3/8 in.)	20 to 25 N-m (200 to 250 kgf-cm)
	12.70 mm (1/2 in.)	25 to 30 N-m (250 to 300 kgf-cm)
	15.88 mm (5/8 in.)	30 to 35 N-m (300 to 350 kgf-cm)
	19.05 mm (3/4 in.)	35 to 40 N-m (350 to 400 kgf-cm)
Charging port cap		10 to 12 N-m (100 to 120 kgf-cm)
Spindle (Hexagon wrench)		6 to 7 N-m (60 to 70 kgf-cm)

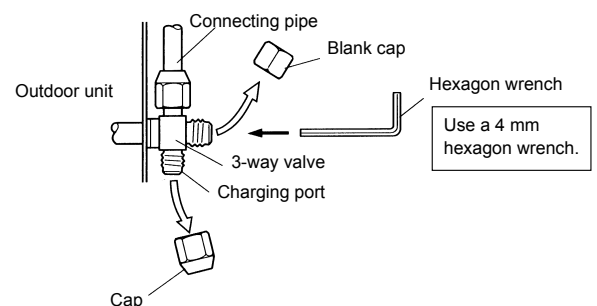
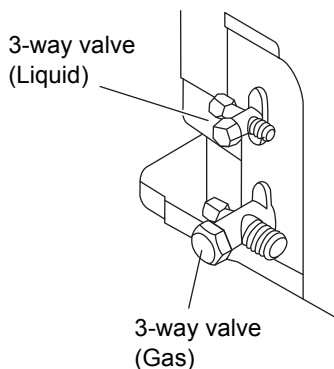

PARTS

INDOOR UNIT Intake grille sub assy

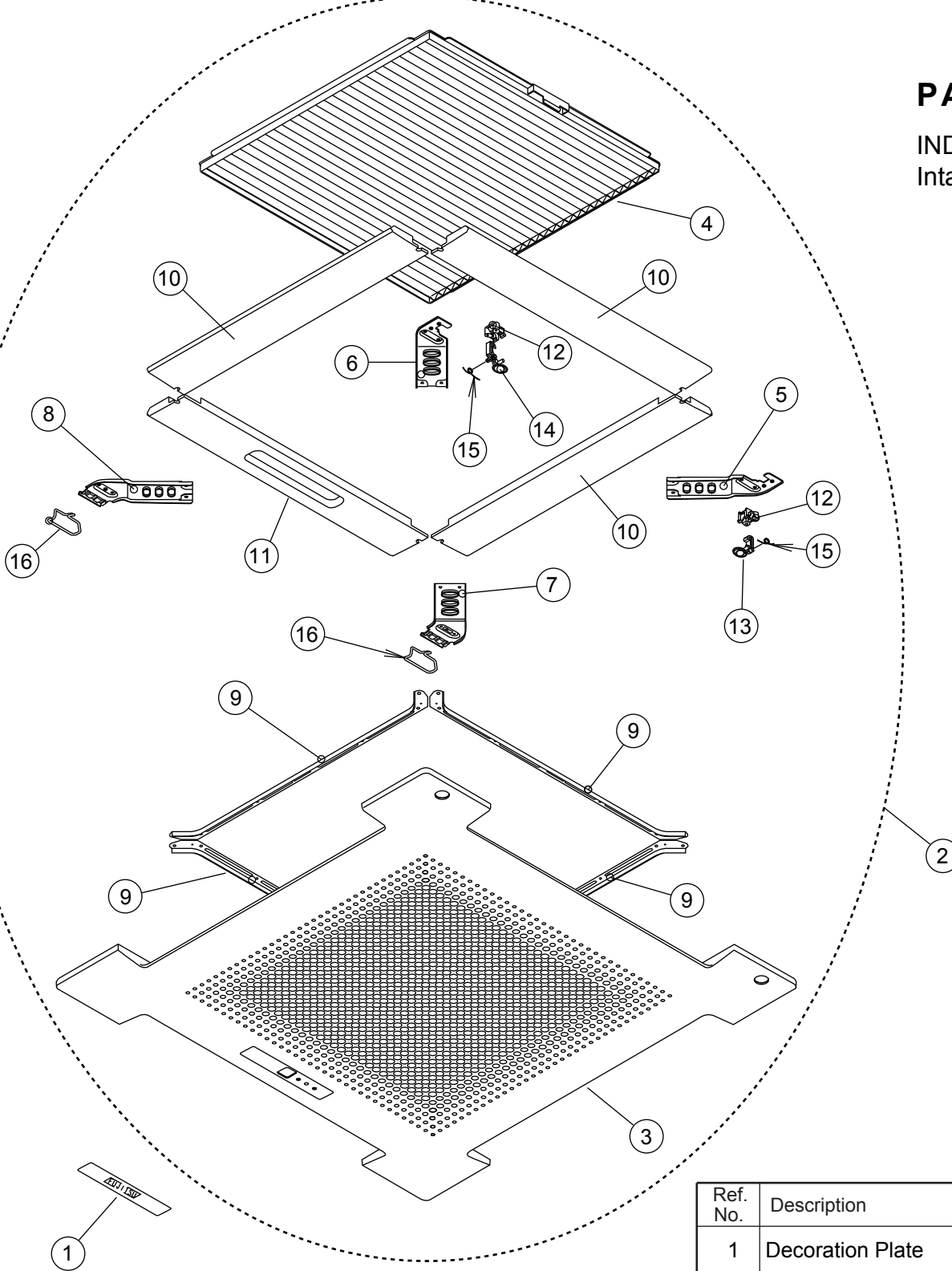

Ref. No.	Description	Parts number	Ord. Q'ty
1	Decoration Plate	9378017023	
2	Intake Grille Sub Assy	9362818131	
3	Intake Grille	9362767019	
4	Filter	9362766005	
5	Grille Reinforcement-T (A)	9362738002	
6	Grille Reinforcement-T (B)	9362739009	
7	Grille Reinforcement-T (C)	9362740005	
8	Grille Reinforcement-T (D)	9362741002	
9	Grille Reinforcement-T (E)	9362742009	
10	Insulation (Grille)-A	9362780001	
11	Insulation (Grille)-B	9362781008	
12	Grille Hook Holder	9362782005	
13	Grille Hook-A	9362779012	
14	Grille Hook-B	9362778015	
15	Grille Spring	9362755009	
16	Grille Hinge Wire	9362754002	

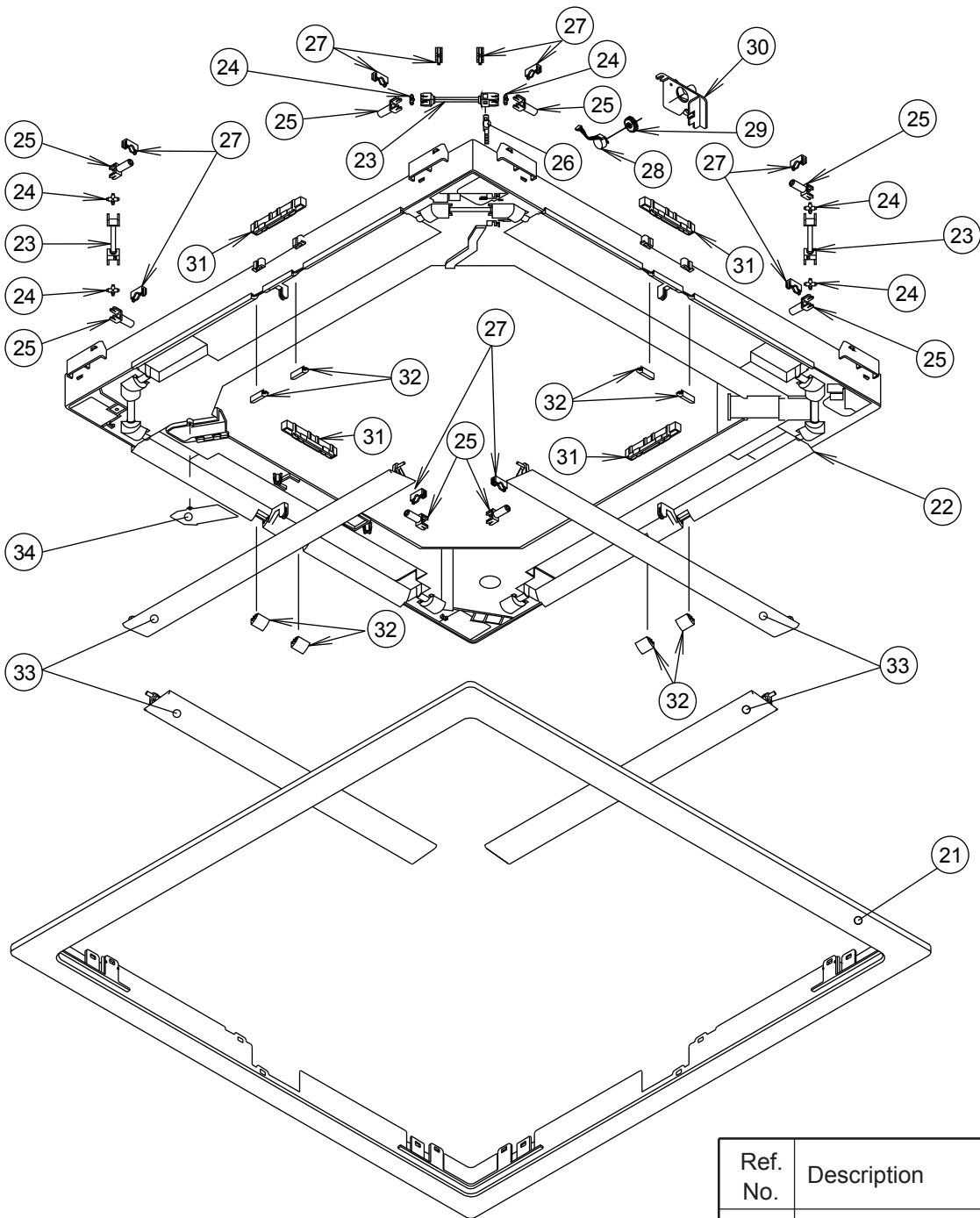

INDOOR UNIT
Panel base

Ref. No.	Description	Part number	Ord. Q'ty
21	Panel Frame Holder	9362758017	
22	Panel Base	9362759014	
23	Joint A	9362773003	
24	Joint Shaft	9362771009	
25	Louver Supporter	9362770019	
26	Joint Gear	9362772006	
27	Rubber Support Holder	9362799003	
28	Step Motor	9900362027	
29	Motor Gear	9362764001	
30	Motor Holder	9362765008	
31	Panel Frame Holder	9362761017	
32	Panel Base Holder	9362760010	
33	Louver Assy	9362836012	
34	Wire Cover-B	9362788007	
35	Spacial Nut-A (Large)	313005446653	
36	Spacial Nut-B (Small)	313005446759	
---	PCB Holder	9364855004	
---	Indicator PCB Assy	9705891036	

INDOOR UNIT
Evaporator
Drain pan

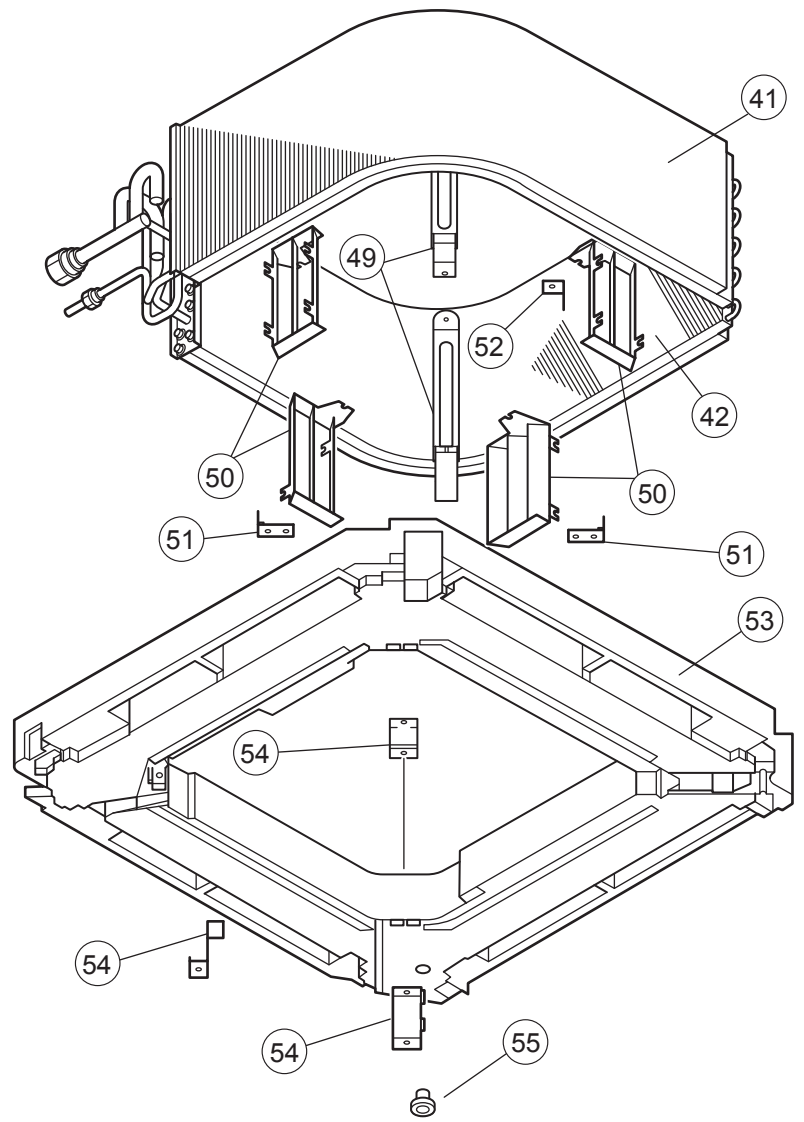
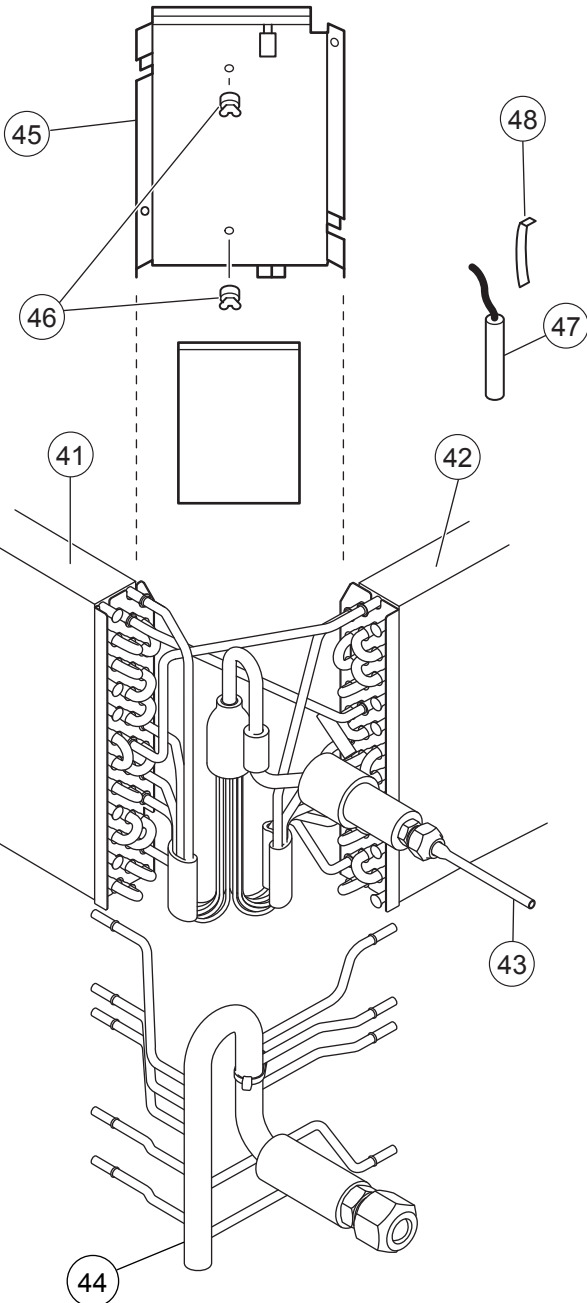
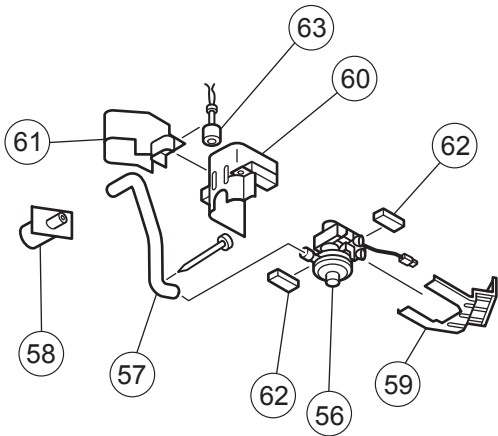

Ref. No.	Description	Parts number	Ord. Q'ty
41	Evaporator A Assy	9373799047	
42	Evaporator B Assy	9373800040	
43	Distributor Assy	9371325101	
44	Coupling Pipe Assy	9373038290	
45	Separate Wall	9362737005	
46	Clamp No.1219	313361271706	
47	Pipe Thermistor	9703297021	
48	Thermistor Spring-A	313728262708	
49	Evaporator Holder Assy	9362802017	
50	Wind Guide Board	9373444015	
51	Reinforcement (Eva.)-A	9362749008	
52	Reinforcement (Eva.)-B	9362750004	
53	Kit (Drain Pan Assy)	9370934021	
54	Reinforcement (Drain Pan)	9362757003	
55	Rubber Cap	313005174654	
56	Pump Unit	9900360030	
57	Drain Hose	9362784009	
58	Drain Port	9362786003	
59	Drain pump Holder	9362753005	
60	Pump Cover-A	9362775007	
61	Pump Cover-B	9362776004	
62	Cushion Rubber (Pump)	9362777001	
63	Float Switch	9900361020	
---	Rubber (Discharge Pipe)	313194159807	

INDOOR UNIT
Fan motor

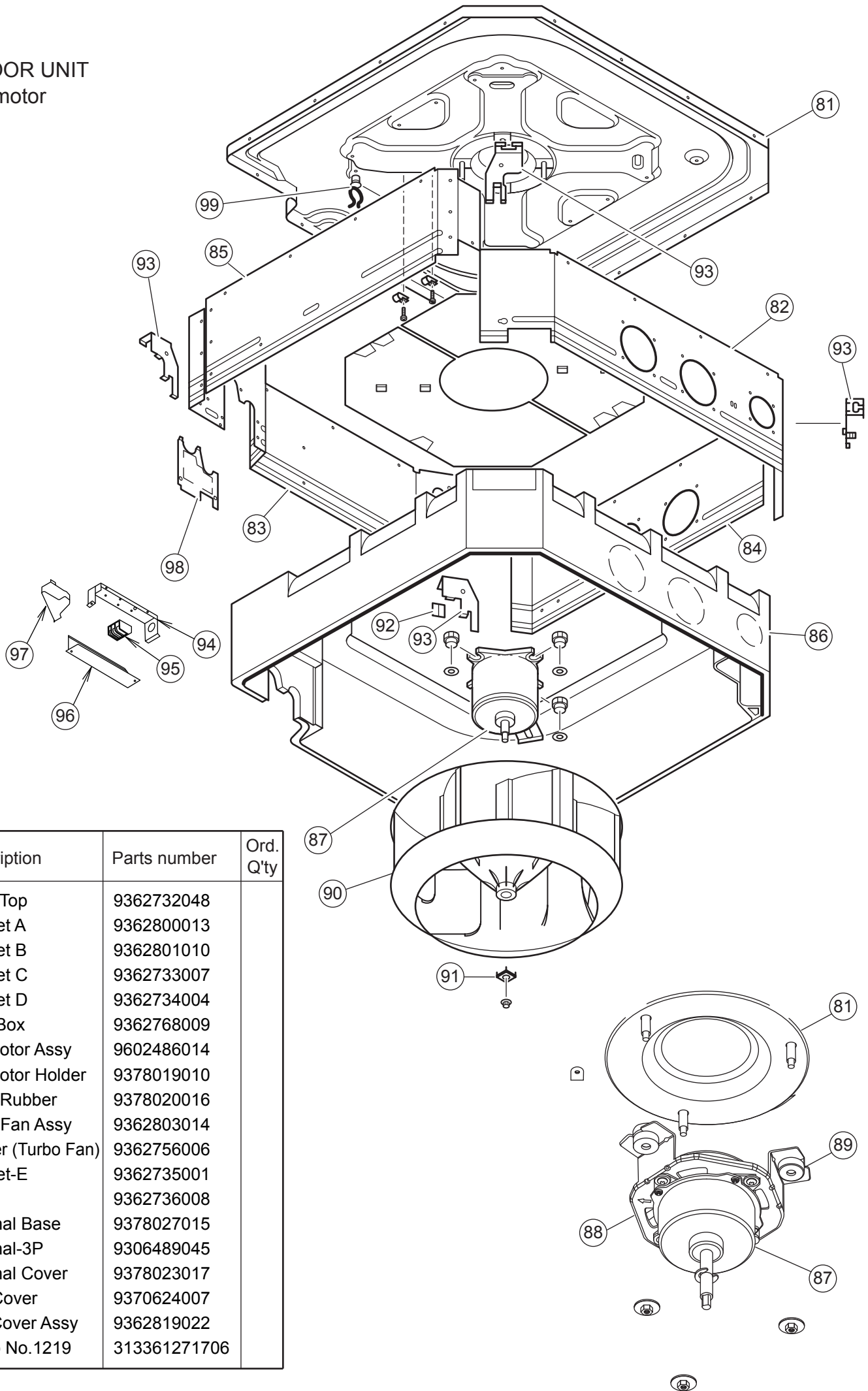

Ref. No.	Description	Parts number	Ord. Q'ty
81	Panel Top	9362732048	
82	Cabinet A	9362800013	
83	Cabinet B	9362801010	
84	Cabinet C	9362733007	
85	Cabinet D	9362734004	
86	Inner Box	9362768009	
87	Fan Motor Assy	9602486014	
88	Fan Motor Holder	9378019010	
89	Motor Rubber	9378020016	
90	Turbo Fan Assy	9362803014	
91	Washer (Turbo Fan)	9362756006	
92	Cabinet-E	9362735001	
93	Hook	9362736008	
94	Terminal Base	9378027015	
95	Terminal-3P	9306489045	
96	Terminal Cover	9378023017	
97	Wire Cover	9370624007	
98	Pipe Cover Assy	9362819022	
99	Clamp No.1219	313361271706	

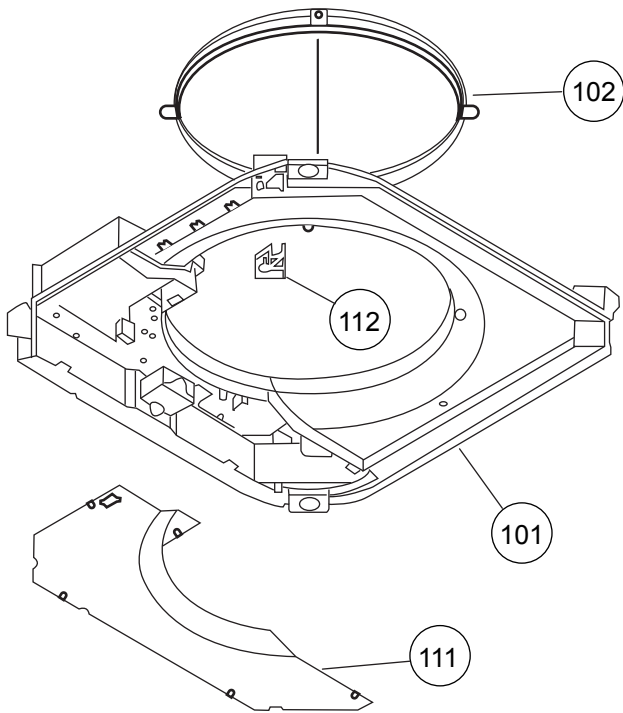

INDOOR UNIT
Control unit

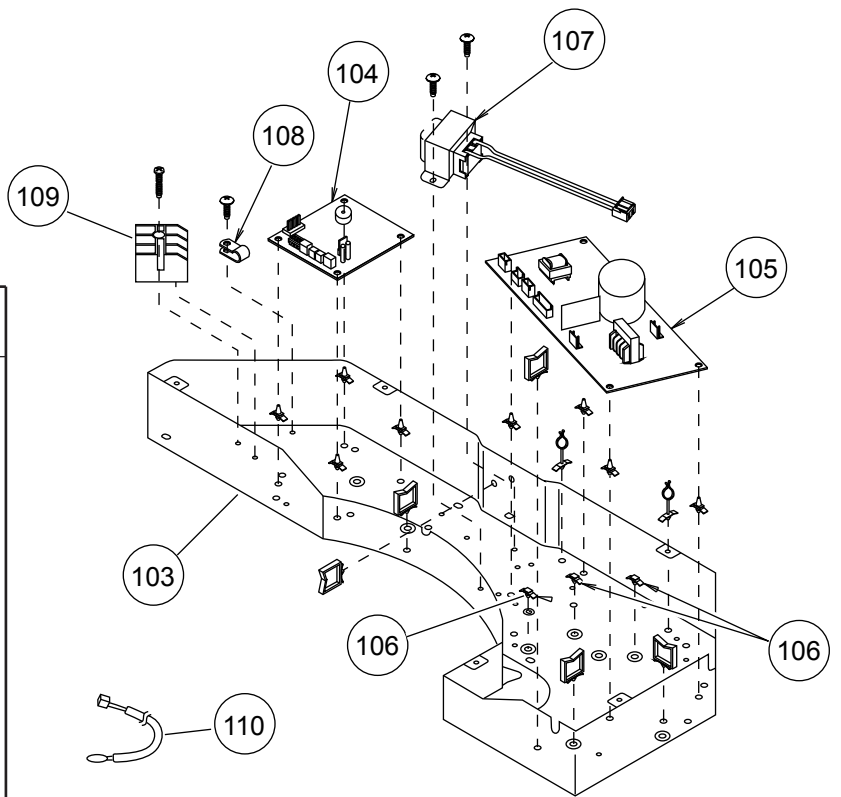

Ref. No.	Description	Parts number	Ord. Q'ty
101	Control Box	9368523015	
102	Bellmouth B	9362774000	
103	Control Box Assy	9368533007	
104	Controller PCB Assy (36)	9707393101	
104	Controller PCB Assy (45)	9707393095	
105	Power Supply PCB Assy	9707398052	
106	Spacer	0600118075	
107	Reactor Assy	9707457018	
108	Clamp NK-4N	313714328805	
109	Terminal-3P	9703345012	
110	Room Thermistor	9703299063	
111	Control Box Cover	9368524005	
112	Wire Cover A	9362789004	

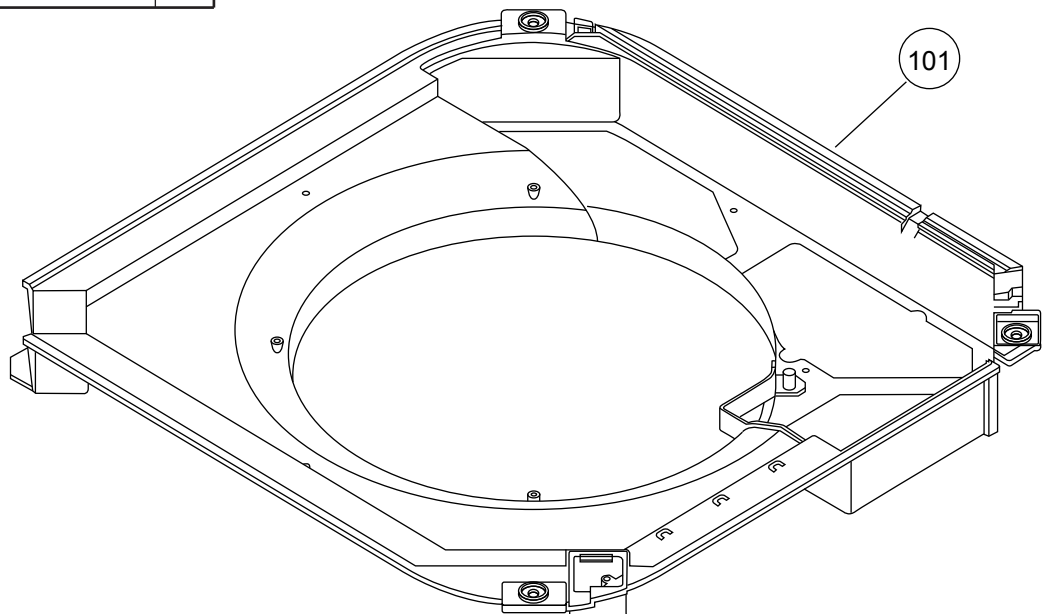

PARTS
OUTDOOR UNIT

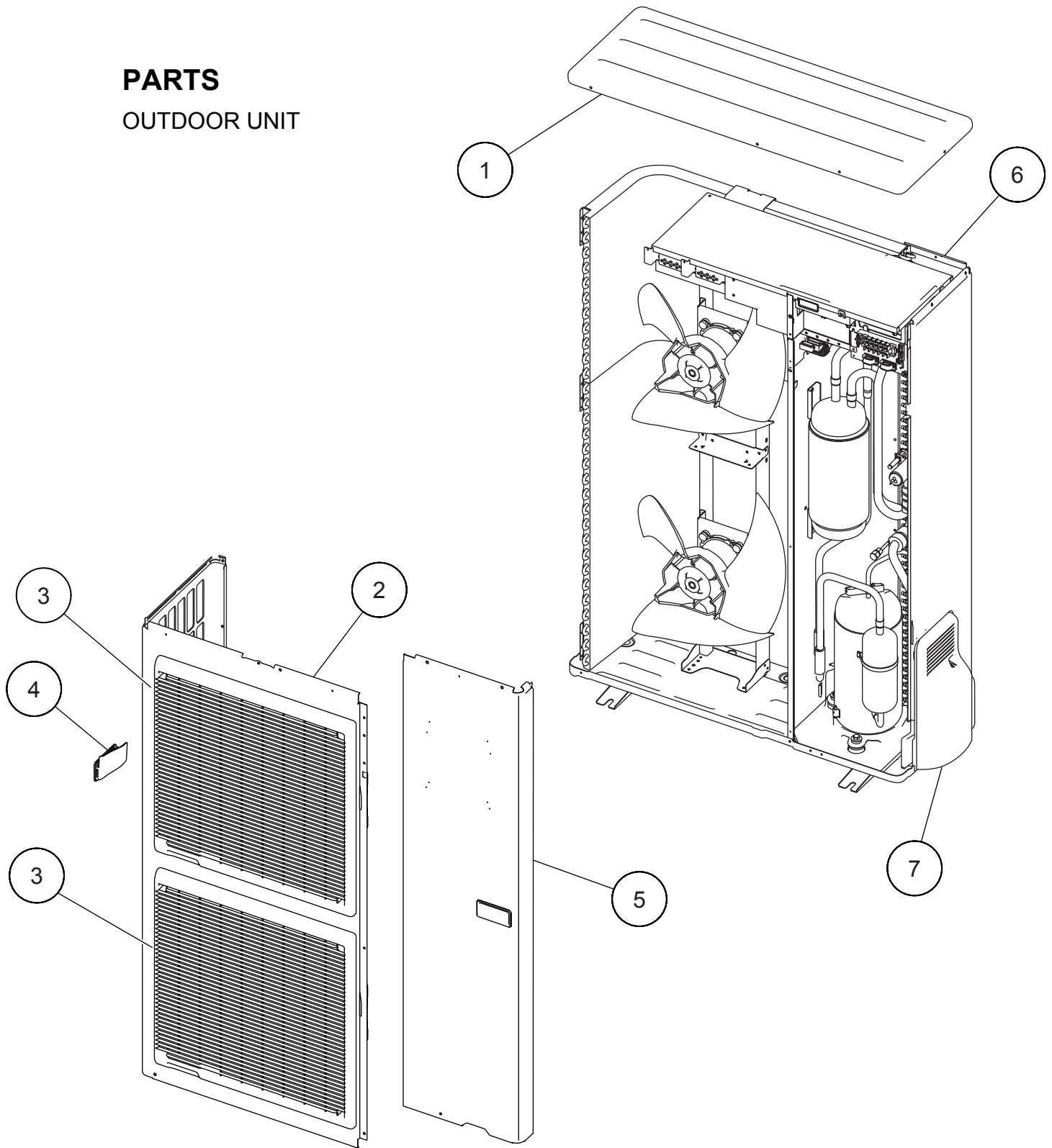

Ref. No.	Description	Parts number	Ord. Q'ty
1	Top Panel Sub Assy	9374417025	
2	Front Panel	9374094028	
3	Fan Guard	9374330010	
4	Grip Side	9374173013	
5	Service Panel Sub Assy	9374415069	
6	Right Panel Sub Assy	9374416141	
7	Valve Cover	9374174010	
--	Emblem Rear	9372171011	

OUTDOOR UNIT

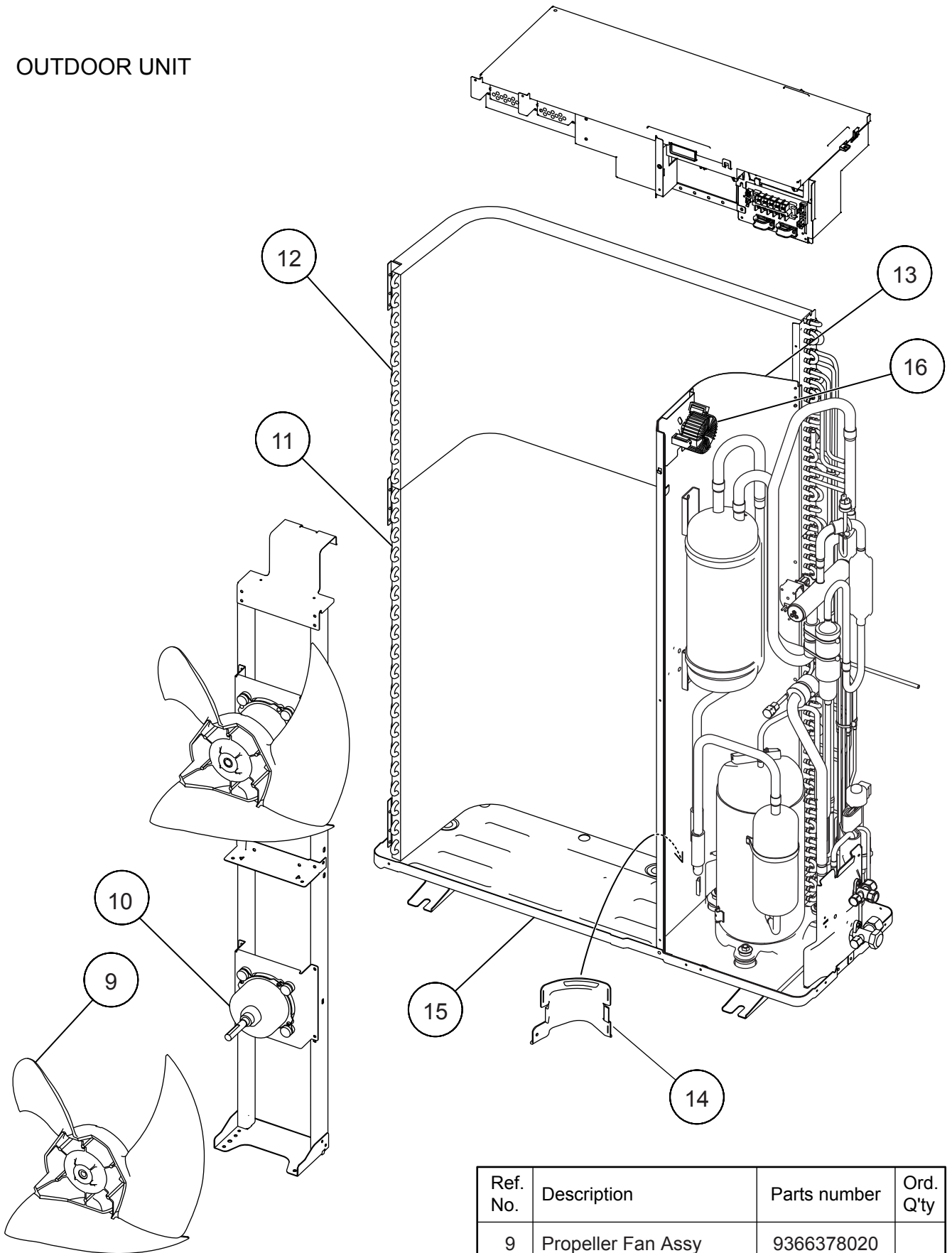

Ref. No.	Description	Parts number	Ord. Q'ty
9	Propeller Fan Assy	9366378020	
10	Motor DC Brushless	9601882015	
11	Condenser A Assy	9374433018	
12	Condenser B Assy	9374434015	
13	Sepa Wall	9374629015	
14	Cap Foot	9374345014	
15	Base Assy	9374166046	
16	Coil Choke	9703458019	

OUTDOOR UNIT

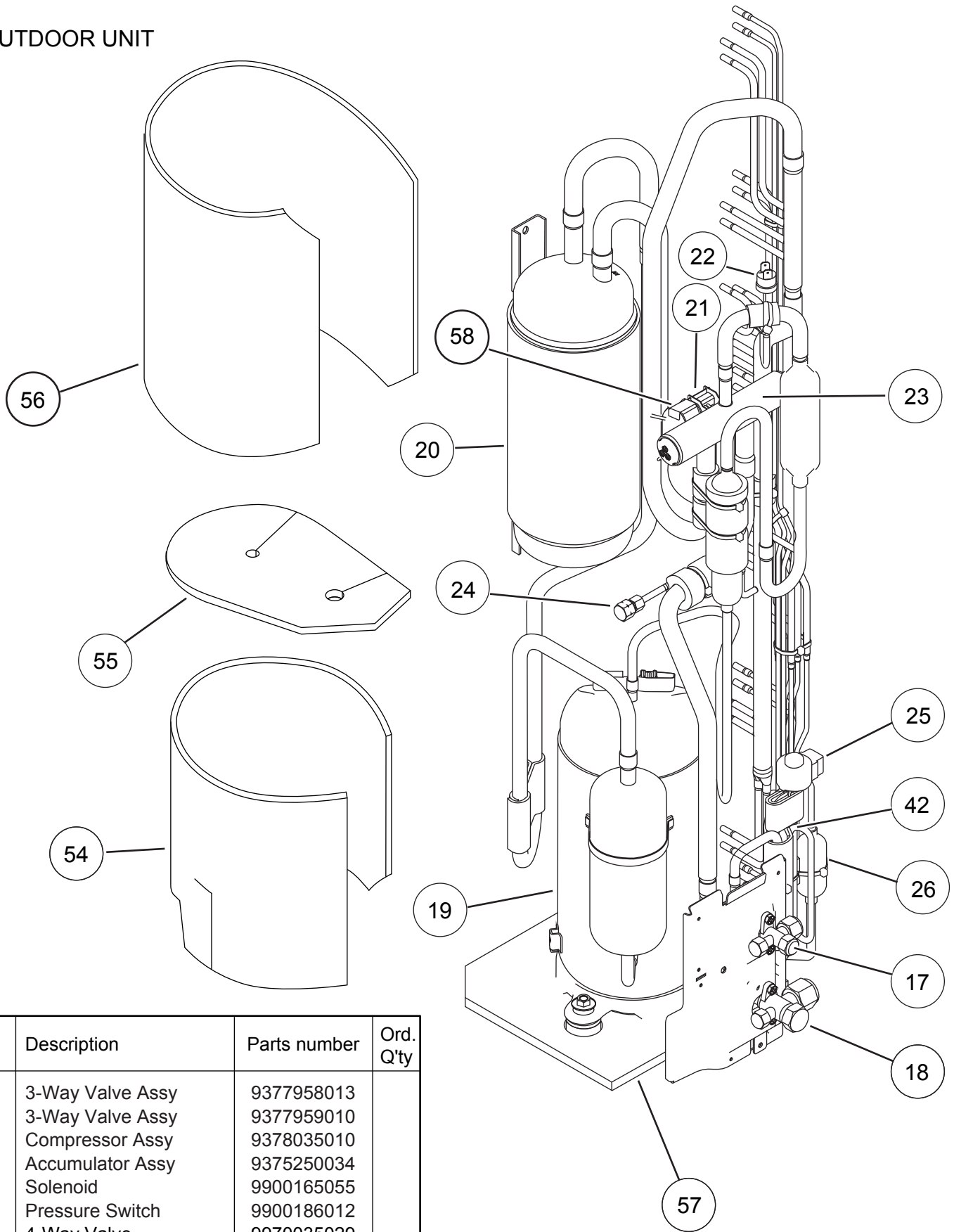

Ref. No.	Description	Parts number	Ord. Q'ty
17	3-Way Valve Assy	9377958013	
18	3-Way Valve Assy	9377959010	
19	Compressor Assy	9378035010	
20	Accumulator Assy	9375250034	
21	Solenoid	9900165055	
22	Pressure Switch	9900186012	
23	4-Way Valve	9970035029	
24	Check Valve Assy	9374274017	
25	Coil (Expansion Valve)	9900197025	
26	Strainer Assy	9372524039	
42	Expansion Valve Assy	9370947175	
54	Compressor Cover A	9374430109	
55	Compressor Cover B	9374431106	
56	Compressor Cover C	9372067086	
57	Compressor Cover D	9375382025	
58	Solenoid	9900165055	





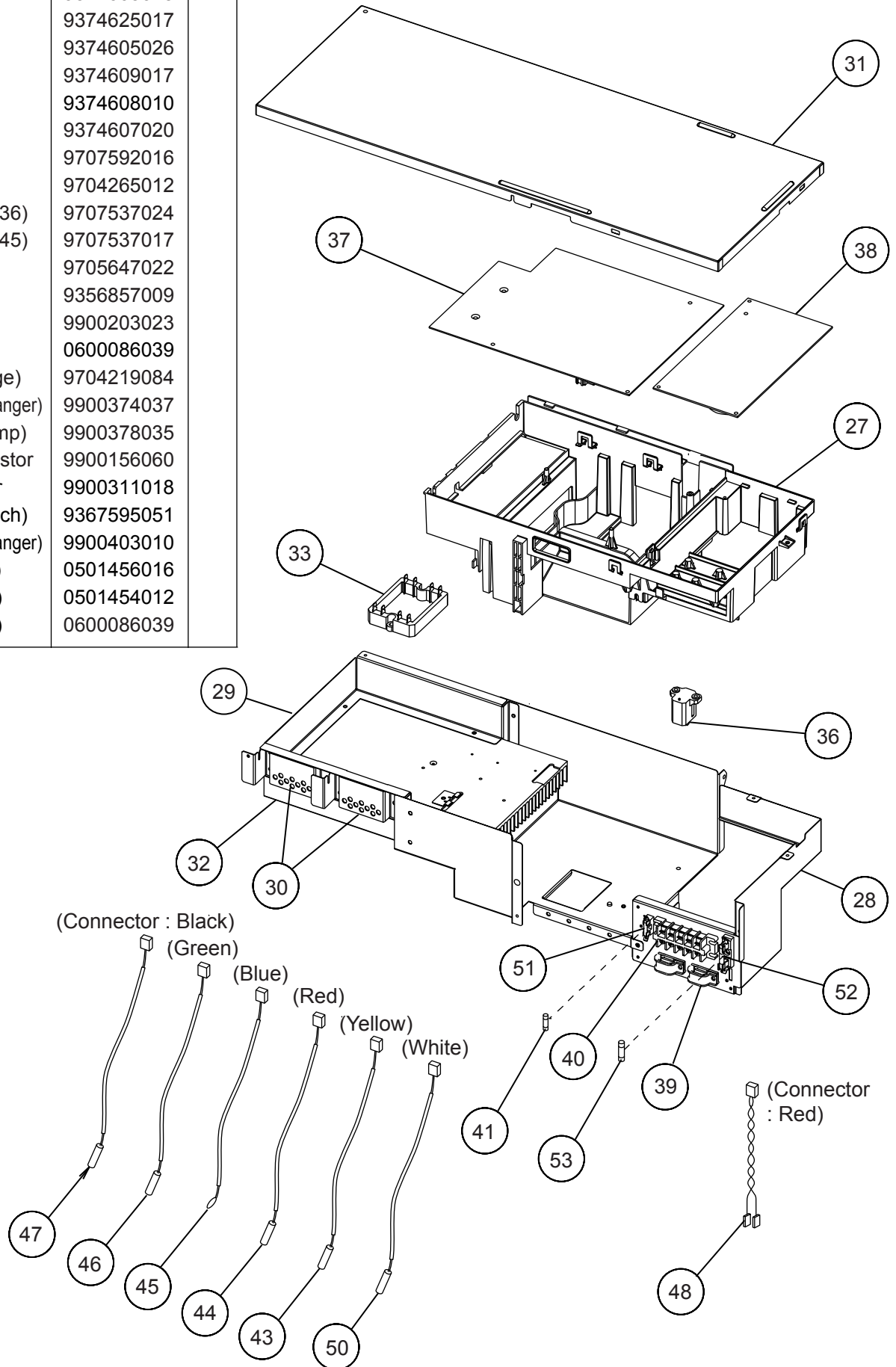



Ref. No.	Description	Parts number	Ord. Q'ty
27	Inverter Box A	9374603015	
28	Inverter Box B	9374625017	
29	Inverter Box C	9374605026	
30	Inverter Box Duct	9374609017	
31	Inverter Box Cover	9374608010	
32	Heat Sink B	9374607020	
33	ACTPM	9707592016	
36	Posistor	9704265012	
37	Inverter PCB Assy (36)	9707537024	
37	Inverter PCB Assy (45)	9707537017	
38	Power PCB Assy	9705647022	
39	Clamp (Cord)	9356857009	
40	Terminal	9900203023	
41	Fuse (Small)	0600086039	
43	Thermistor (Dischage)	9704219084	
44	Thermistor (Heat Exchanger)	9900374037	
45	Thermistor (Out Temp)	9900378035	
46	Compressor Thermistor	9900156060	
47	Heatsink Thermistor	9900311018	
48	Wire (Pressure Switch)	9367595051	
50	Thermistor (Heat Exchanger)	9900403010	
51	Fuse Holder (Small)	0501456016	
52	Fuse Holder (Large)	0501454012	
53	Fuse Holder (Large)	0600086039	

OUTDOOR UNIT



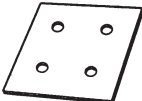
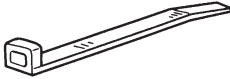

STANDARD ACCESSORIES

INDOOR UNIT

Name and Shape	Q'ty	Application
Coupler heat insulation 	2	For indoor side pipe joint
Tapping Screw (flush heads) 	2	For installing the remote controller (option)
Special nut A (large flange) 	4	For installing indoor unit
Special nut B (small flange) 	4	For installing indoor unit
Template 	1	For ceiling hole cutting
Binder 	1	For fixing the remote controller cord
Blower cover insulation 	2	For discharged air
Hook wire 	2	For installing intake grille
Rubber sheet 	2	For wiring cover

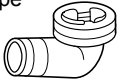
OUTDOOR UNIT

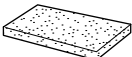
Name and Shape	Q'ty	Application	Part No.
Drain pipe 	1	For outdoor unit drain piping work (May not be supplied, depending on the model)	9303029015
Drain cap 	2		313166024302
Installation (seal) 	1	For filling in a gap at the entrance of connection cords	9374756018

0701G3196