

INDOOR UNIT

1. CASSETTE TYPE :

AU * A36LATU

AU * A45LATU

1. FEATURE

■ MODEL :

AU *A36LATU / AO *A36LATL

AU *A45LATU / AO *A45LATL



■ FEATURES

● Energy saving

High energy saving was realized by making the indoor unit and outdoor unit fan motor and compressor all DC and optimal design of the refrigerant cycle. Rank A was achieved in European energy rank.

● Easy maintenance

The control box is easily accessible for maintenance work.

● Long-life filter

High efficiency, long-life filter extends the cleaning cycle.

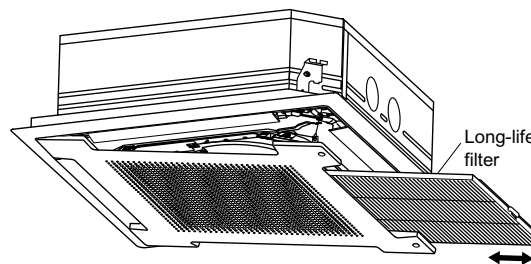

● Slim intake grille

Slim type intake grille can fit the ceiling after installation.

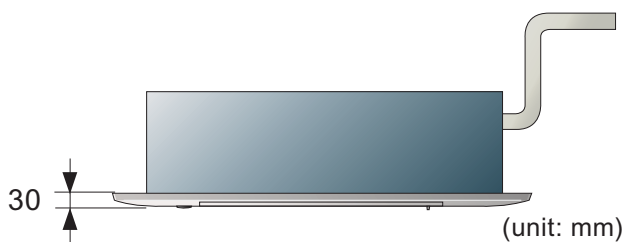

● Duct connection hole opening

Fresh air can be introduced through this opening.

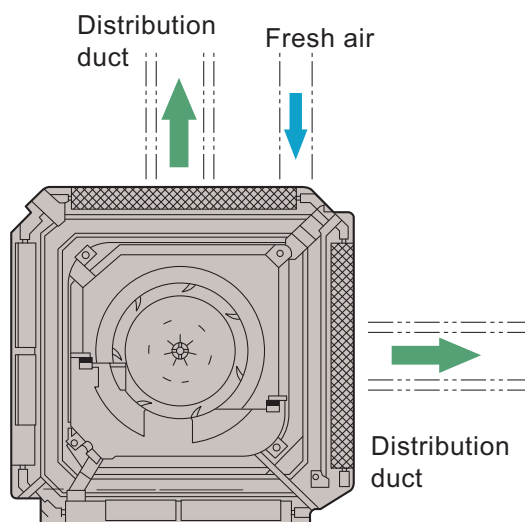

● Conditioned air can be distributed by means of a distribution duct.

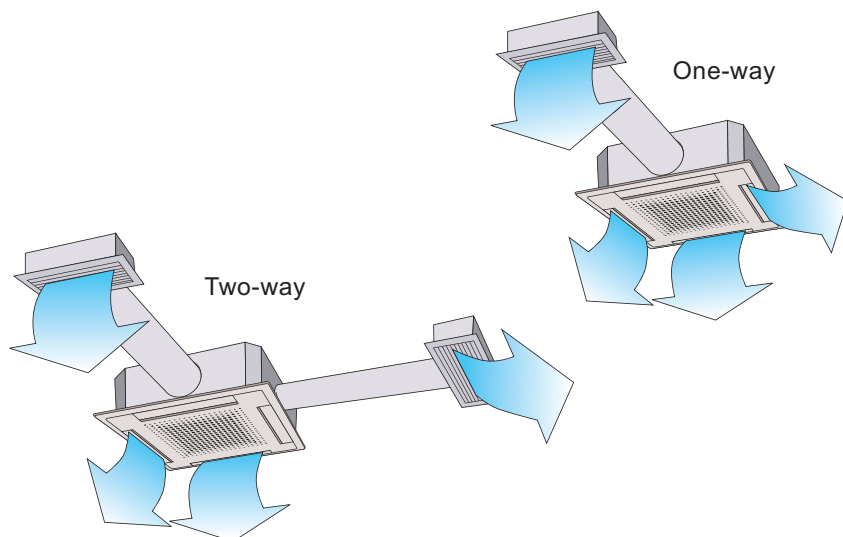

● EASY INSTALLATION

Easy setting by wireless or wired remote controller.

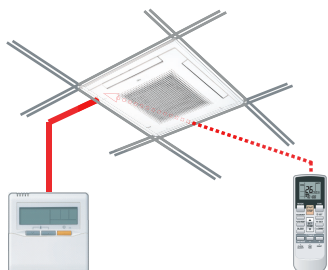

● OTHER FUNCTIONS

- Setting the filter sign
The indoor unit has sign to inform the user that it is time to clean the filter
- Setting the cooler room temperature correction
- Setting the heater room temperature correction
- Auto restart

2. REMOTE CONTROLLER

WIRED REMOTE CONTROLLER

FEATURES

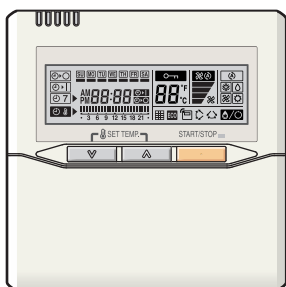

- * Various timer setup (ON / OFF / WEEKLY) are possible.
- * Equipped with weekly timer as standard function. (2 times Start / Stop per day for a week)
- * When setting up a timer, operation mode and a temperature setup can be changed.
- * When a failure occurs, the error code is displayed. (Maximum of 16)
- * Error indication. (A maximum of 16 error histories are memorizable.)
- * Up to 16 indoor units can be simultaneously controlled.
- * Economy operation are possible.
- * Easy installation with a slim shape with no bulge in the back.
- * The room temperature can be controlled by being detected the temperature accurately with built-in thermo sensor.

Simple function setting

Setting of the air conditioner selection function is performed by remote controller.

High performance and compact size

Three functions are combined in one unit.



Built-in timers

Weekly timer	Setback timer
<p>Possible to set ON/OFF time to operate twice each day of the week.</p> <p>Easy-to-understand time bar display</p> <p>Screen after setup</p> <p>Setup screen example (Set to Wednesday: 8:00 to 20:00.)</p>	<p>Possible to set temperature for two time spans and for each day of the week.</p> <p>Setup screen example (Set from Sunday to Saturday: 12:00 to 15:00, 28 °C.)</p>
At "Weekly timer" + "Set back timer" setup	
<p style="text-align: center; border: 1px solid red; padding: 2px;">24°C → 28°C → 24°C</p>	

Easy-to-understand operation

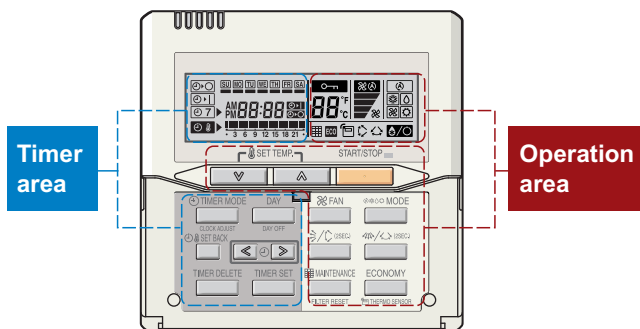

[Variable timer control]
The operation/display sections are zoned according to time and operation, enabling variable programming to match application.

Simple installation

Components are compatible with standard switch boxes. Flat back construction allows equipment to be installed wherever it is needed.

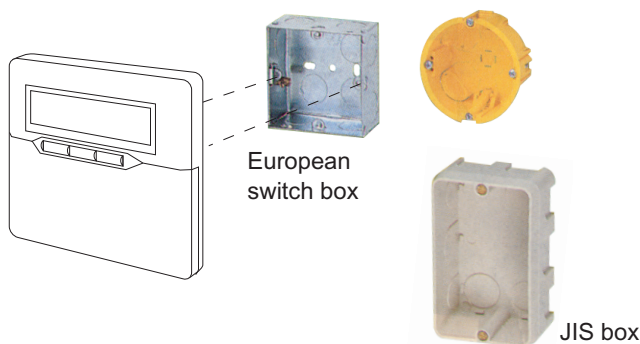

FUNCTIONS

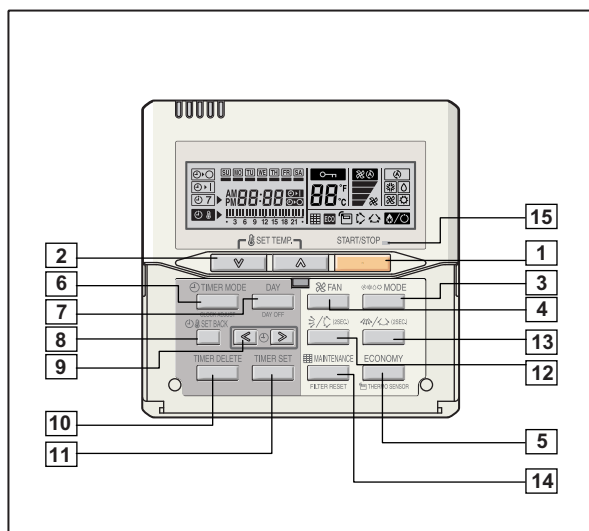

Display panel

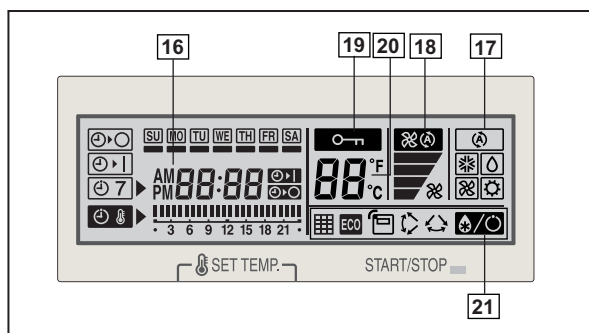

- 1 START/STOP button
Pressed to start and stop operation.
- 2 Set temperature button
Selects the setting temperature.
- 3 Master control button
Selects the operating mode(AUTO, HEAT, FAN, COOL, DRY).
- 4 Fan control button
Selects the fan speed (AUTO, QUIET, LOW, MED, HIGH).
- 5 Economy button
Turns the economy efficient mode on and off.
- 6 Timer mode (CLOCK ADJUST) button
Selects the timer mode (OFF TIMER, ON TIMER, WEEKLY TIMER).
Set the current time.
- 7 Day (DAY OFF) button
Temporarily cancels of one day timer.
- 8 Set back button
Pressed to select the set back timer.
- 9 Set time button
Pressed to set time.
- 10 Delete button
The schedule of a weekly timer is deleted.
- 11 Set button
Sets the date, hour, minute and on-off time.
- 12 Vertical airflow direction and swing button
Push for two seconds to change the swing mode.
- 13 Horizontal airflow direction and swing button*
Push for two seconds to change the swing mode.
- 14 Filter button
- 15 Operation lamp
Lights during operation and when the timer is on.
- 16 Timer and clock display
- 17 Operation mode display
- 18 Fan speed display
- 19 Operation lock display
- 20 Temperature display
- 21 Function display
 - Defrost display
 - Thermo sensor display
 - Economy display
 - Vertical swing display
 - Horizontal swing display*
 - Filter display

DIMENSION

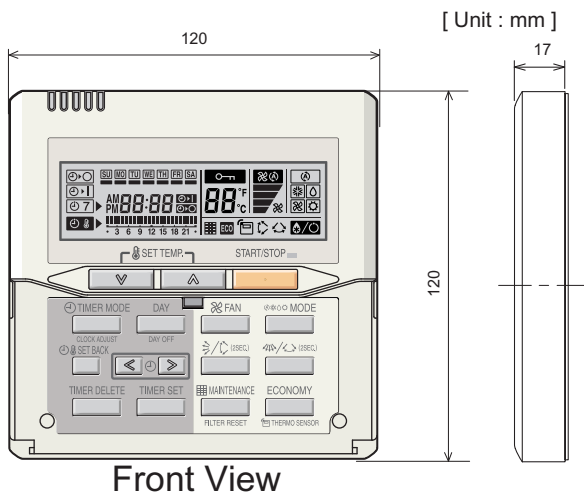

SPECIFICATION

SIZE (H x W x D mm)	120 x 120 x 17
WEIGHT (g)	160
CABLE LENGTH (m)	10
POWER (V)	12

*These functions are not available.

3. SPECIFICATIONS

Type			CASSETTE MODEL			
			INVERTER HEATPUMP			
Model name			AU * A36LATU	AU * A45LATU		
Power source			230V ~ 50Hz			
Available voltage range			198-264V ~ 50Hz			
European energy label			Cooling	A		
			Heating	A		
Capacity	Cooling	Rated	kW	10.00	12.50	
			BTU/h	34100	42700	
		Min.- Max.	kW	3.80 - 11.20	4.00 - 14.00	
	BTU/h		13000 - 38200	13700 - 47800		
	Heating	Rated	kW	11.20	14.00	
			BTU/h	38200	47800	
Min.- Max.		kW	4.00 - 14.00	4.20 - 16.20		
	BTU/h	13700 - 47800	14300 - 55300			
Input power	Cooling	Rated	kW	3.11	3.89	
		*Max.		4.33	4.56	
	Heating	Rated		3.02	3.77	
		*Max.		4.33	4.56	
Current	Cooling	Rated	A	13.6	17.0	
		*Max.		19.0	20.0	
	Heating	Rated		13.2	16.5	
		*Max.		19.0	20.0	
EER	Cooling	kW/kW	3.21	3.21		
COP	Heating		3.71	3.71		
Moisture removal			l/h (pints/h)	3.5 (6.2)	4.5 (7.9)	
Fan	Airflow rate	Cooling	High	m ³ /h	1650	1750
			Med		1370	1430
			Low		1140	1200
			Quiet		930	1030
		Heating	High		1650	1750
			Med		1370	1430
			Low		1140	1200
			Quiet		990	1030
	Type × Q'ty			Turbo × 1		
	Motor output			W	116	116
Sound pressure level	Cooling	High	dB(A)	50	52	
		Med		46	47	
		Low		41	42	
		Quiet		36	39	
	Heating	High		50	52	
		Med		46	47	
		Low		41	42	
		Quiet		37	39	
Heat exchanger type	Dimensions (H × W × D)		mm	252 × 970 × 39.9 × 2 pieces	252 × 970 × 39.9 × 2 pieces	
	Fin pitch			1.4	1.4	
	Rows x Stages			3 × 12	3 × 12	
	Pipe type			Copper	Copper	
	Fin type			Aluminium	Aluminium	
Enclosure (Panel)	Material		ABS			
	Colour		White			
Dimensions (H × W × D)	Net		mm		296 × 830 × 830	
	Gross				455 × 1060 × 1025	
Weight	Net		kg(lb.)		39 (86)	
	Gross				54 (119)	
Connection pipe	Size	Liquid	mm	φ 9.52 (φ 3 / 8 in.)	φ 9.52 (φ 3 / 8 in.)	
		Gas		φ 15.88 (φ 5 / 8 in.)	φ 15.88 (φ 5 / 8 in.)	
	Method			Flare		Flare
Operation range	Cooling	°C	18 to 32	18 to 32		
		%RH	80 or less	80 or less		
	Heating	°C	30 or less	30 or less		
Remote controller type			WIRED			
Drain pipe	Material		ABS			
	Size		mm		Outer diameter : 37.0 / Inner diameter : 32.0	

Note :

Specifications are based on the following conditions.

Cooling : Indoor temperature of 27 °CDB / 19 °CWB and outdoor temperature of 35 °CDB/24 °CWB.

Heating : Indoor temperature of 20 °CDB / 15 °CWB and outdoor temperature of 7 °CDB/6 °CWB.

Pipe length : 7.5 m, Height difference : 0 m.(Outdoor unit - Indoor unit)

* The maximum current and the maximum input value are the maximum values when operated within the operation range (temperature).

4. DIMENSIONS

■ MODEL : AU*A36L, AU*A45L

(Unit : mm)

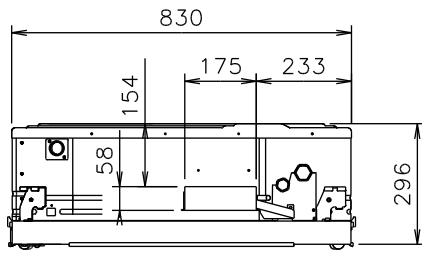

Side view

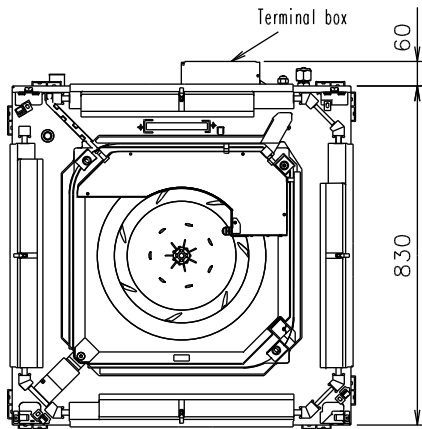

Bottom view

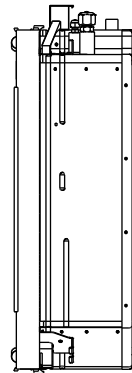

Panel mounting state

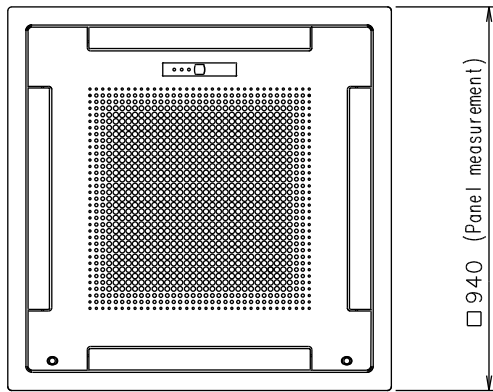

Bottom view

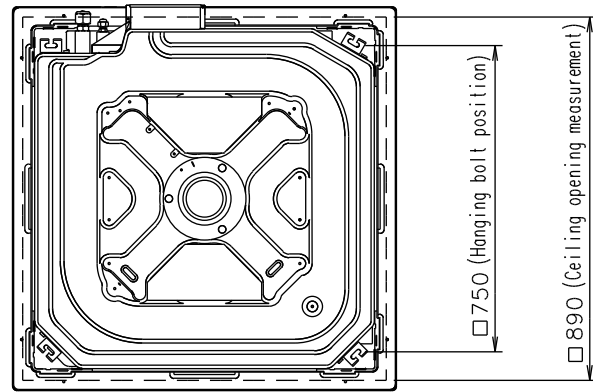

Top view

■ SELECTION OF SETTING

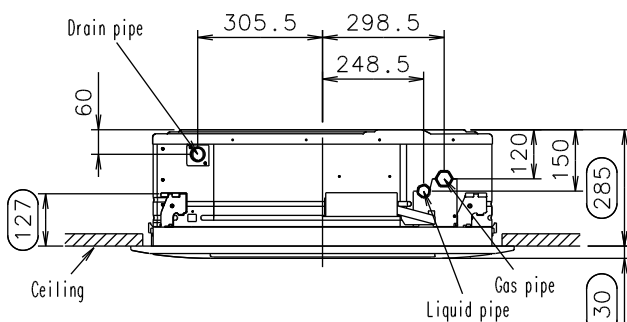

Side view (Standard setting)

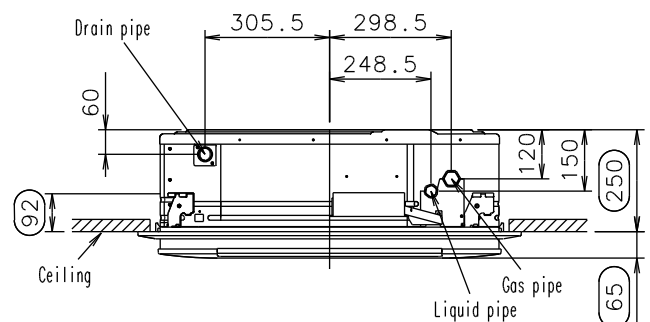

Side view (Slender setting)

※ The unit is factory-set to "Standard setting".

■ MOUNTING POSITION

(Unit : mm)

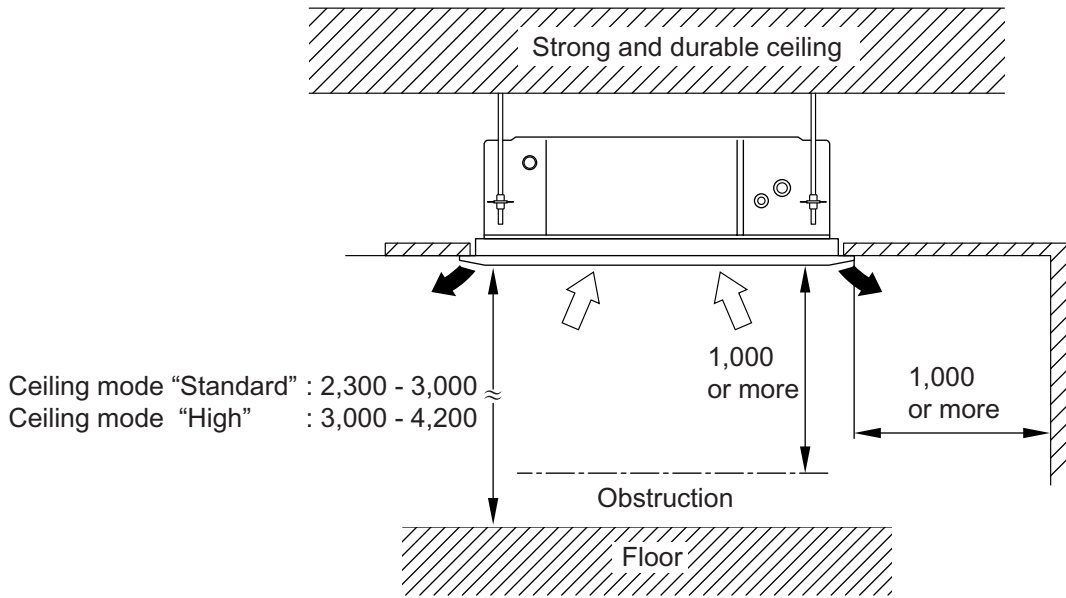

You can select 2-way setting

(A) Standard setting

(B) Slender setting

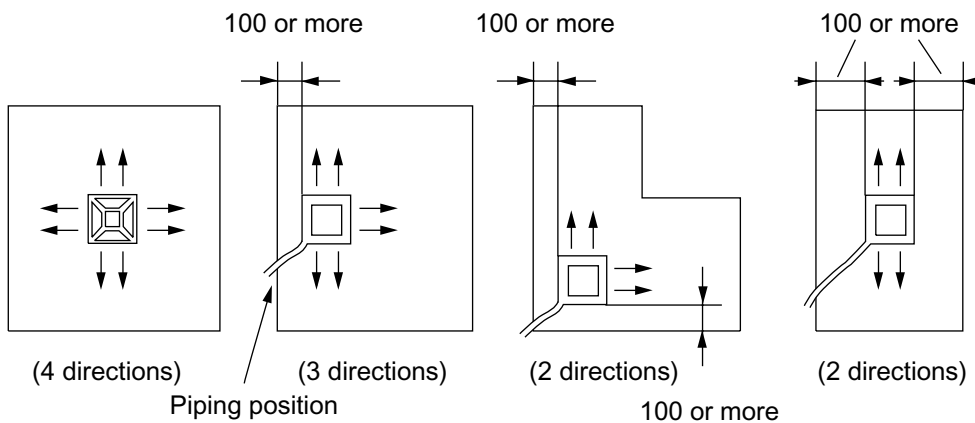
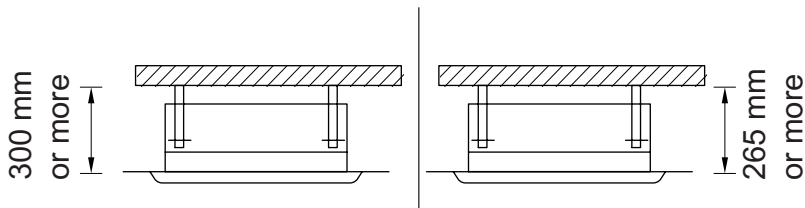

5. WIRING DIAGRAMS

■ MODEL : AU*A36L, AU*A45L

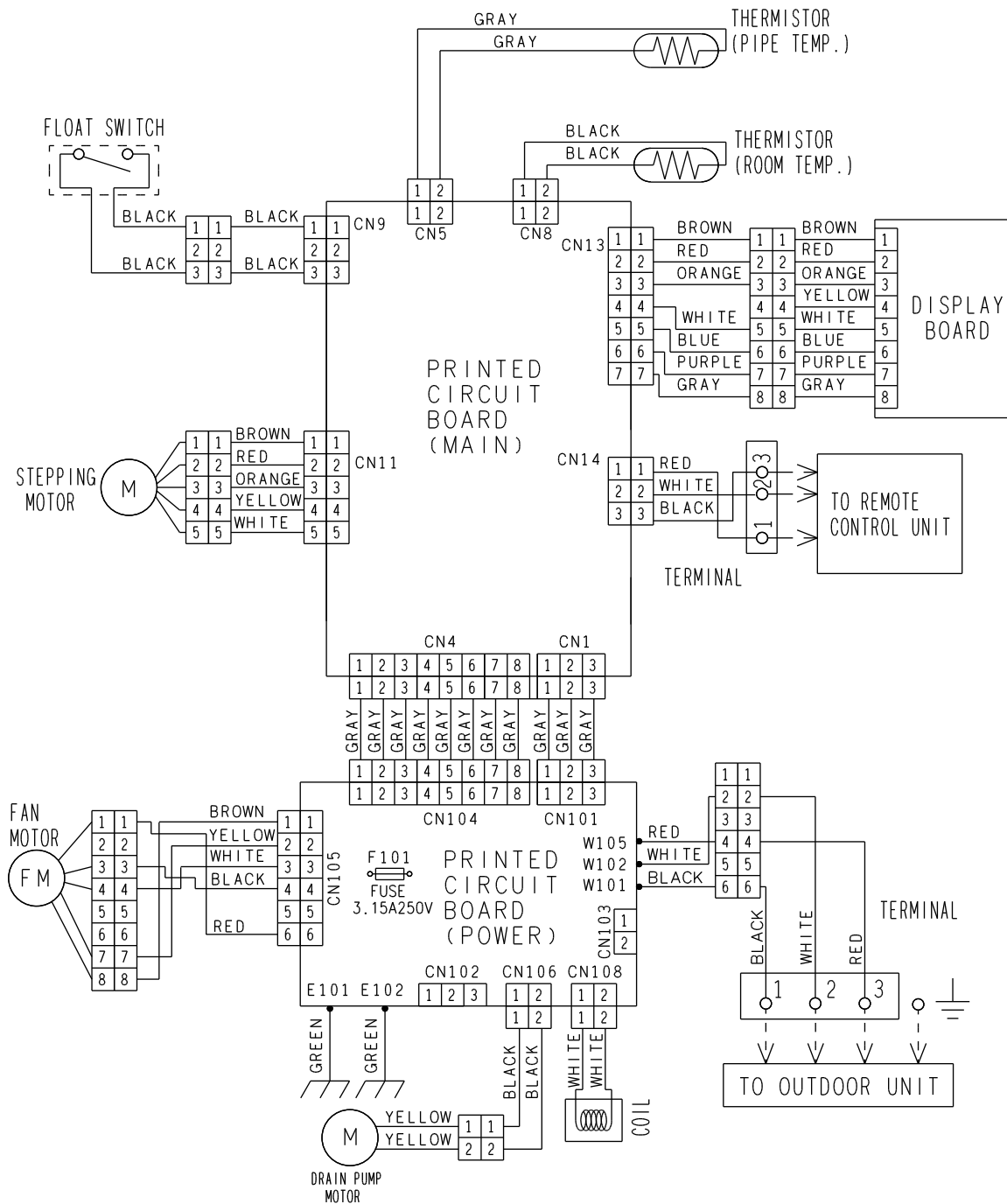

6. CAPACITY TABLE

6-1. COOLING CAPACITY

This table is created using the maximum capacity.

■ MODEL : AU*A36L

AFR	27.2
-----	------

	°CDB	Indoor temperature																						
		18			21			23			25			27			29			32				
		°CWB			12			15			16			18			19			21			23	
Outdoor temperature	°CDB	TC	SHC	PI	TC	SHC	PI	TC	SHC	PI	TC	SHC	PI	TC	SHC	PI	TC	SHC	PI	TC	SHC	PI		
	-15	9.86	7.28	1.17	10.98	7.32	1.19	11.35	7.96	1.19	12.10	7.99	1.20	12.48	8.63	1.21	13.23	8.59	1.22	13.97	9.15	1.23		
	-10	9.52	7.11	1.41	10.61	7.16	1.43	10.97	7.78	1.44	11.69	7.80	1.45	12.05	8.43	1.46	12.78	8.39	1.48	13.50	8.94	1.49		
	0	9.67	7.19	1.27	10.78	7.23	1.29	11.14	7.86	1.29	11.88	7.89	1.31	12.25	8.52	1.31	12.98	8.48	1.33	13.72	9.04	1.34		
	5	9.32	7.02	1.50	10.38	7.06	1.53	10.74	7.67	1.53	11.45	7.70	1.55	11.80	8.31	1.56	12.51	8.28	1.57	13.22	8.82	1.59		
	10	9.35	7.03	1.46	10.41	7.07	1.48	10.77	7.69	1.49	11.48	7.71	1.50	11.83	8.33	1.51	12.54	8.29	1.53	13.25	8.84	1.54		
	15	8.96	6.84	1.70	9.98	6.88	1.72	10.33	7.48	1.73	11.01	7.50	1.75	11.35	8.10	1.76	12.03	8.07	1.78	12.71	8.60	1.79		
	20	10.93	7.82	2.55	12.18	7.87	2.59	12.59	8.56	2.60	13.42	8.58	2.63	13.84	9.27	2.64	14.67	9.23	2.67	15.50	9.84	2.70		
	25	10.79	7.75	2.65	12.01	7.80	2.69	12.42	8.48	2.71	13.24	8.51	2.73	13.65	9.19	2.75	14.47	9.15	2.77	15.29	9.75	2.80		
	30	10.28	7.49	2.96	11.45	7.54	3.01	11.84	8.19	3.02	12.62	8.22	3.05	13.01	8.88	3.07	13.80	8.84	3.10	14.58	9.42	3.13		
	35	8.85	6.20	3.37	9.86	6.23	3.42	10.19	6.78	3.44	10.86	6.80	3.47	11.20	7.34	3.49	11.87	7.31	3.52	12.54	7.79	3.56		
	40	7.97	6.36	2.82	8.88	6.40	2.87	9.18	6.96	2.88	9.78	6.98	2.91	10.09	7.54	2.93	10.69	7.51	2.96	11.30	8.00	2.99		
46	5.60	5.28	2.20	6.23	5.31	2.24	6.45	5.77	2.25	6.87	5.79	2.27	7.08	6.25	2.28	7.51	6.23	2.31	7.93	6.63	2.33			

■ MODEL : AU*A45L

AFR	28.8
-----	------

	°CDB	Indoor temperature																						
		18			21			23			25			27			29			32				
		°CWB			12			15			16			18			19			21			23	
Outdoor temperature	°CDB	TC	SHC	PI	TC	SHC	PI	TC	SHC	PI	TC	SHC	PI	TC	SHC	PI	TC	SHC	PI	TC	SHC	PI		
	-15	10.81	8.39	1.43	12.05	8.44	1.45	12.46	9.18	1.46	13.28	9.21	1.48	13.69	9.94	1.48	14.51	9.91	1.50	15.33	10.55	1.51		
	-10	10.44	8.19	1.72	11.63	8.24	1.75	12.03	8.96	1.76	12.82	8.99	1.77	13.22	9.71	1.78	14.01	9.67	1.80	14.80	10.30	1.82		
	0	10.62	8.30	1.55	11.83	8.35	1.57	12.23	9.07	1.58	13.04	9.10	1.60	13.44	9.83	1.61	14.25	9.79	1.62	15.05	10.43	1.64		
	5	10.23	8.08	1.83	11.39	8.13	1.86	11.78	8.84	1.87	12.56	8.86	1.89	12.95	9.57	1.90	13.72	9.53	1.92	14.50	10.16	1.93		
	10	10.26	8.10	1.77	11.43	8.15	1.80	11.82	8.86	1.81	12.60	8.88	1.83	12.99	9.59	1.84	13.77	9.56	1.86	14.55	10.18	1.87		
	15	9.84	7.87	2.05	10.96	7.92	2.09	11.33	8.61	2.10	12.08	8.64	2.12	12.46	9.33	2.13	13.20	9.29	2.15	13.95	9.90	2.17		
	20	12.05	9.07	3.08	13.43	9.12	3.13	13.88	9.92	3.14	14.80	9.95	3.18	15.26	10.74	3.19	16.17	10.70	3.22	17.09	11.40	3.26		
	25	11.89	8.99	3.20	13.24	9.04	3.25	13.70	9.83	3.27	14.60	9.86	3.30	15.05	10.65	3.32	15.95	10.60	3.35	16.86	11.30	3.39		
	30	11.33	8.68	3.58	12.62	8.73	3.64	13.05	9.49	3.66	13.91	9.52	3.70	14.34	10.28	3.71	15.20	10.24	3.75	16.06	10.91	3.79		
	35	11.06	8.53	4.21	12.32	8.58	4.27	12.74	9.33	4.29	13.58	9.36	4.34	14.00	10.11	4.36	14.84	10.07	4.40	15.68	10.73	4.45		
	40	8.74	7.30	3.41	9.74	7.34	3.47	10.07	7.98	3.48	10.73	8.01	3.52	11.06	8.65	3.54	11.73	8.62	3.57	12.39	9.18	3.61		
46	6.11	5.98	2.67	6.81	6.02	2.71	7.04	6.54	2.72	7.50	6.56	2.75	7.74	7.08	2.76	8.20	7.06	2.79	8.66	7.52	2.79			

AFR : Air flow rate(m³/min)
 TC : Total capacity (kW)
 SHC : Sensible Heat capacity (kW)
 PI : Power Input (kW)

6-2. HEATING CAPACITY

This table is created using the maximum capacity.

■ MODEL : AU*A36L

AFR	27.2
-----	------

		Indoor temperature										
		°CDB	16		18		20		22		24	
Outdoor temperature	°CDB	°CWB	TC	PI	TC	PI	TC	PI	TC	PI	TC	PI
	-15	-16	9.97	3.60	9.73	3.67	9.50	3.75	9.26	3.82	9.02	3.90
	-10	-11	10.89	3.61	10.64	3.68	10.38	3.76	10.12	3.83	9.86	3.91
	-5	-7	11.64	3.58	11.36	3.65	11.08	3.73	10.81	3.80	10.53	3.87
	0	-2	12.66	3.61	12.36	3.69	12.06	3.77	11.76	3.84	11.46	3.92
	5	3	13.88	3.61	13.55	3.69	13.22	3.76	12.89	3.84	12.56	3.91
	7	6	14.70	3.62	14.35	3.69	14.00	3.77	13.65	3.85	13.30	3.92
	10	8	15.14	3.58	14.78	3.66	14.42	3.73	14.06	3.81	13.70	3.88
	15	10	14.64	3.19	14.29	3.25	13.94	3.32	13.59	3.39	13.24	3.45
	20	15	14.20	2.81	13.86	2.87	13.52	2.93	13.18	2.98	12.84	3.04
24	18	14.87	2.80	14.52	2.86	14.16	2.92	13.81	2.98	13.45	3.03	

■ MODEL : AU*A45L

AFR	28.8
-----	------

		Indoor temperature										
		°CDB	16		18		20		22		24	
Outdoor temperature	°CDB	°CWB	TC	PI	TC	PI	TC	PI	TC	PI	TC	PI
	-15	-16	11.72	4.23	11.44	4.32	11.16	4.41	10.88	4.50	10.60	4.54
	-10	-11	12.73	4.25	12.43	4.34	12.13	4.43	11.82	4.52	11.52	4.56
	-5	-7	13.59	4.23	13.27	4.32	12.94	4.40	12.62	4.49	12.30	4.54
	0	-2	14.61	4.17	14.26	4.26	13.91	4.35	13.56	4.43	13.22	4.52
	5	3	16.04	4.18	15.66	4.27	15.28	4.35	14.90	4.44	14.52	4.53
	7	6	17.01	4.20	16.60	4.28	16.20	4.37	15.79	4.46	15.39	4.55
	10	8	17.53	4.16	17.11	4.25	16.70	4.33	16.28	4.42	15.86	4.51
	15	10	16.18	3.41	15.80	3.49	15.41	3.56	15.03	3.63	14.64	3.70
	20	15	15.81	3.05	15.44	3.12	15.06	3.18	14.68	3.24	14.31	3.31
24	18	16.56	3.04	16.17	3.10	15.77	3.17	15.38	3.23	14.99	3.29	

AFR : Air flow rate(m³/min)
TC : Total capacity (kW)
PI : Power Input (kW)

7. FAN PERFORMANCE

7-1. AIR VELOCITY DISTRIBUTION

■ MODEL : AU *A36L

● 4-WAY AIR OUTLET

Note :

Condition

Fan speed : High

Operation mode : FAN

Ceiling mode : Standard

(m) Unit : m/s

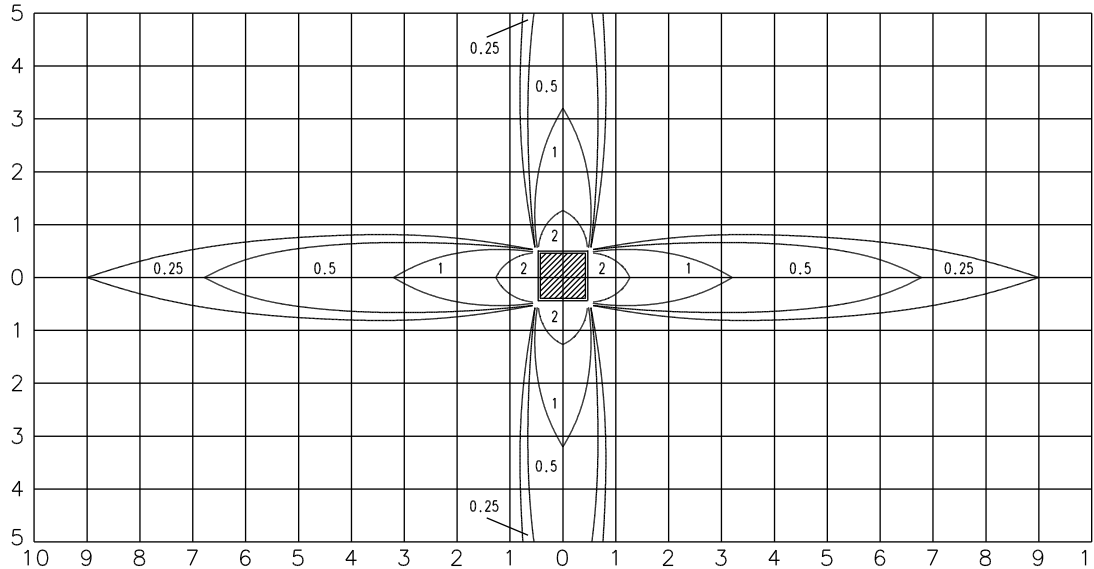

(m) Unit : m/s

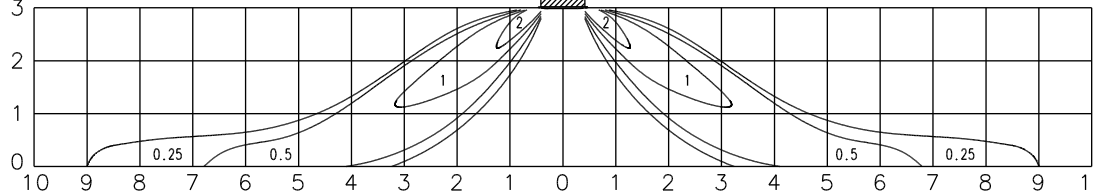

(m) Unit : m/s

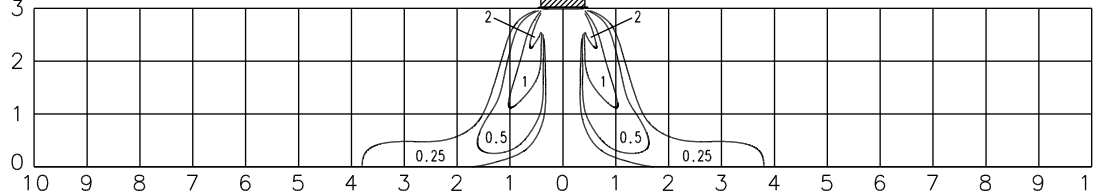

MODEL : AU *A45L

4-WAY AIR OUTLET

Note :

Condition

Fan speed : High

Operation mode : FAN

Ceiling mode : Standard

Unit : m/s

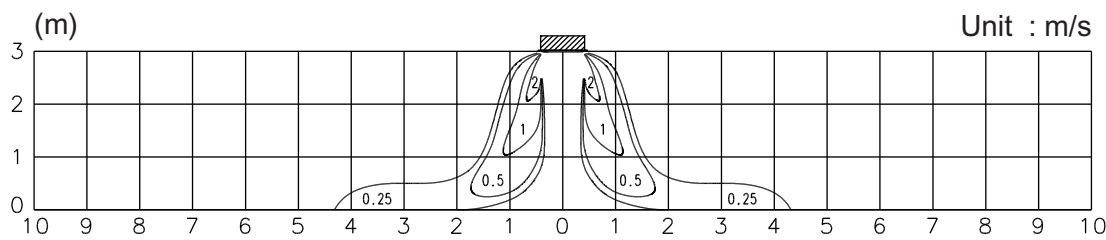
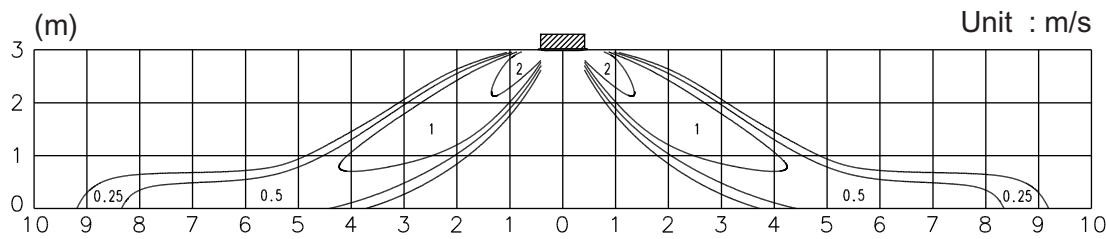
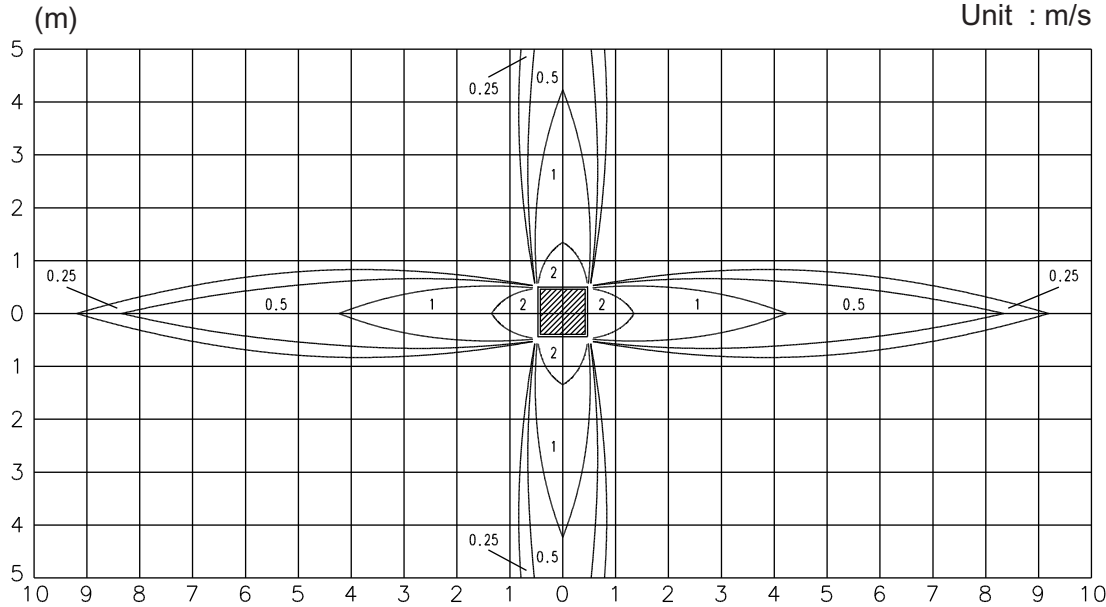

■ MODEL : AU*A36L, AU*A45L

Note :
Condition
Fan speed : High
Operation mode : FAN
Ceiling mode : Standard

● 3-WAY AIR OUTLET

(m) Unit : m/s

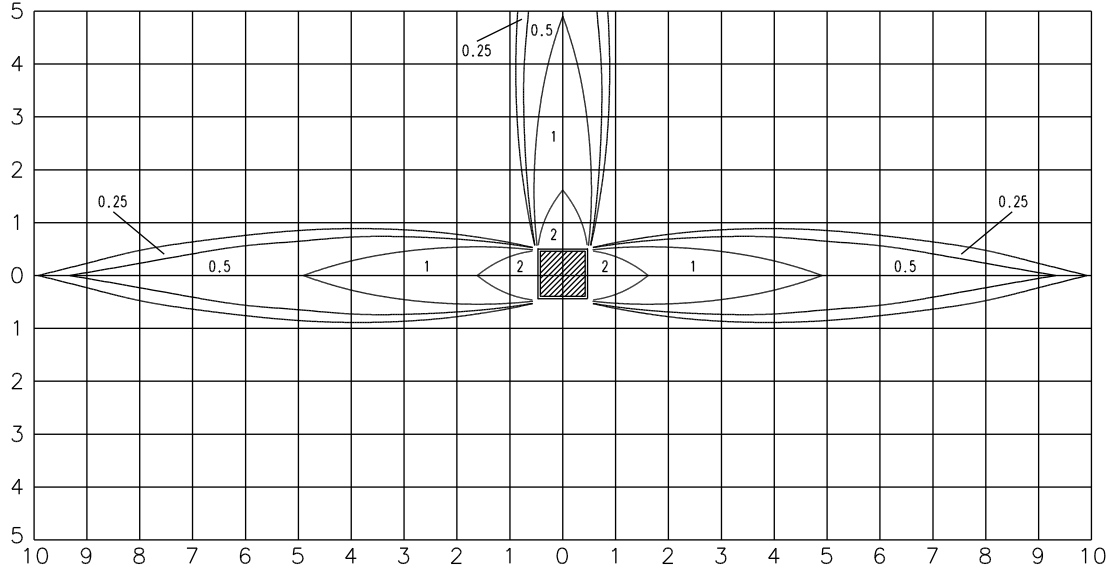

TOP VIEW
HORIZONTAL LOUVER
: Upward
(m)

(m) Unit : m/s

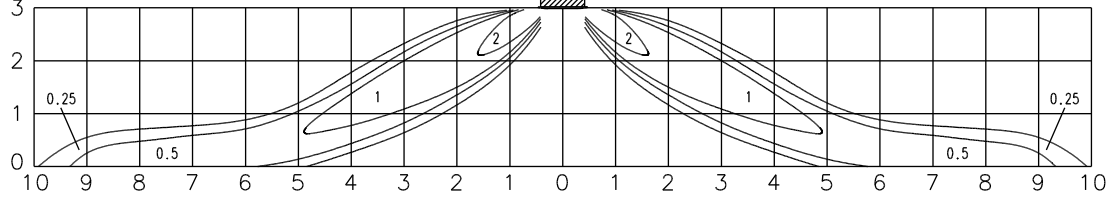

SIDE VIEW
HORIZONTAL LOUVER
: Upward
(m)

(m) Unit : m/s

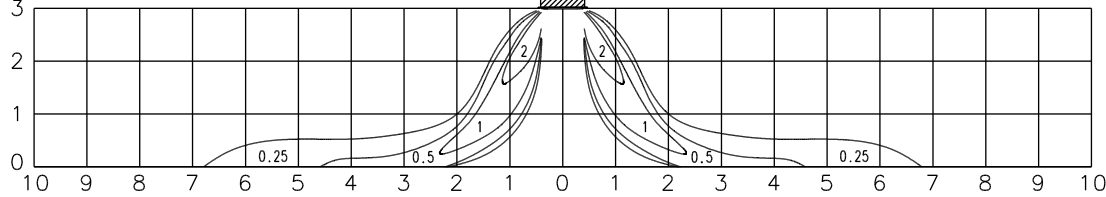

SIDE VIEW
HORIZONTAL LOUVER
: Downward
(m)

MODEL : AU*A36L, AU*A45L

2-WAY AIR OUTLET

Note :
Condition
Fan speed : High
Operation mode : FAN
Ceiling mode : Standard

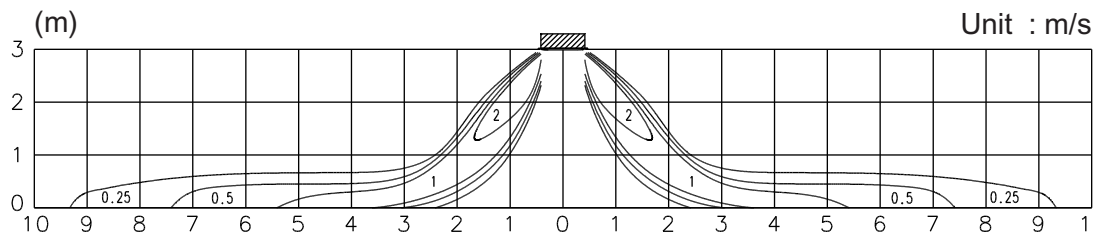
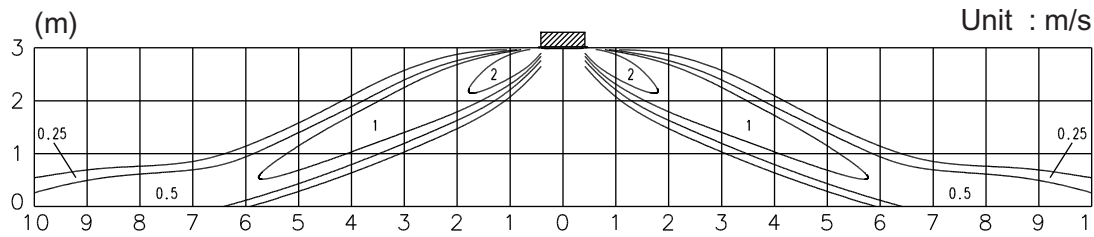
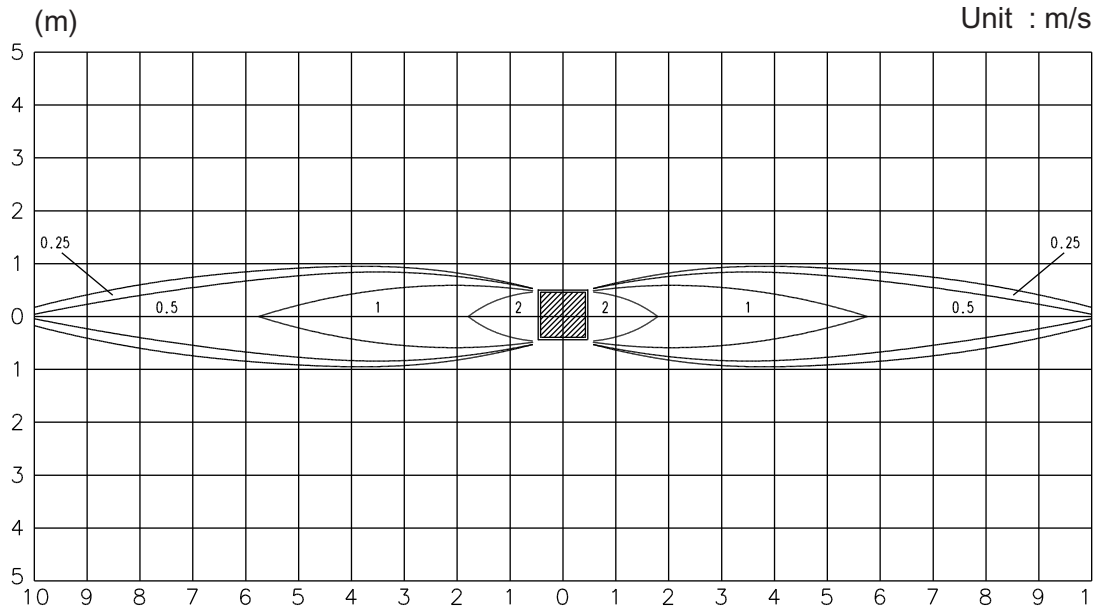

7-2. AIR FLOW

7-2-1. STANDARD CEILING MODE

■ MODEL : AU*A36L

● COOLING

Fan speed	Number of rotations (r.p.m)	Air flow	
		m ³ /h	l/s
HIGH	680	m ³ /h	1650
		l/s	458
		CFM	971
MED	570	m ³ /h	1370
		l/s	381
		CFM	806
LOW	480	m ³ /h	1140
		l/s	317
		CFM	671
QUIET	400	m ³ /h	930
		l/s	258
		CFM	547

● HEATING

Fan speed	Number of rotations (r.p.m)	Air flow	
		m ³ /h	l/s
HIGH	680	m ³ /h	1650
		l/s	458
		CFM	971
MED	570	m ³ /h	1370
		l/s	381
		CFM	806
LOW	480	m ³ /h	1140
		l/s	317
		CFM	671
QUIET	420	m ³ /h	990
		l/s	275
		CFM	583

■ **MODEL : AU*A45L**

● **COOLING**

Fan speed	Number of rotations (r.p.m)	Air flow	
		m ³ /h	l/s
HIGH	720	m ³ /h	1750
		l/s	486
		CFM	1030
MED	590	m ³ /h	1430
		l/s	397
		CFM	842
LOW	500	m ³ /h	1200
		l/s	333
		CFM	706
QUIET	440	m ³ /h	1030
		l/s	286
		CFM	606

● **HEATING**

Fan speed	Number of rotations (r.p.m)	Air flow	
		m ³ /h	l/s
HIGH	720	m ³ /h	1750
		l/s	486
		CFM	1030
MED	590	m ³ /h	1430
		l/s	397
		CFM	842
LOW	500	m ³ /h	1200
		l/s	333
		CFM	706
QUIET	440	m ³ /h	1030
		l/s	286
		CFM	606

7-2-2. HIGH CEILING MODE

■ MODEL : AU*A36L

● COOLING

Fan speed	Number of rotations (r.p.m)	Air flow	
		m ³ /h	l/s
HIGH	720	m ³ /h	1750
		l/s	486
		CFM	1030
MED	620	m ³ /h	1500
		l/s	417
		CFM	883
LOW	530	m ³ /h	1270
		l/s	353
		CFM	747
QUIET	450	m ³ /h	1060
		l/s	294
		CFM	624

● HEATING

Fan speed	Number of rotations (r.p.m)	Air flow	
		m ³ /h	l/s
HIGH	720	m ³ /h	1750
		l/s	486
		CFM	1030
MED	620	m ³ /h	1500
		l/s	417
		CFM	883
LOW	530	m ³ /h	1270
		l/s	353
		CFM	747
QUIET	470	m ³ /h	1110
		l/s	308
		CFM	653

■ MODEL : AU*A45L

● COOLING

Fan speed	Number of rotations (r.p.m)	Air flow	
		m ³ /h	l/s
HIGH	720	m ³ /h	1750
		l/s	486
		CFM	1030
MED	640	m ³ /h	1550
		l/s	431
		CFM	912
LOW	550	m ³ /h	1320
		l/s	367
		CFM	777
QUIET	490	m ³ /h	1160
		l/s	322
		CFM	683

● HEATING

Fan speed	Number of rotations (r.p.m)	Air flow	
		m ³ /h	l/s
HIGH	720	m ³ /h	1750
		l/s	486
		CFM	1030
MED	640	m ³ /h	1550
		l/s	431
		CFM	912
LOW	550	m ³ /h	1320
		l/s	367
		CFM	777
QUIET	490	m ³ /h	1160
		l/s	322
		CFM	683

7-2-3. 3-WAY OUTLET MODE

■ MODEL : AU*A36L

● COOLING / HEATING

Fan speed	Number of rotations (r.p.m)	Air flow	
		m ³ /h	l/s
HIGH	720	m ³ /h	1470
		l/s	408
		CFM	865
MED	690	m ³ /h	1400
		l/s	389
		CFM	824
LOW	660	m ³ /h	1340
		l/s	372
		CFM	789
QUIET	640	m ³ /h	1300
		l/s	361
		CFM	765

■ MODEL : AU*A45L

● COOLING / HEATING

Fan speed	Number of rotations (r.p.m)	Air flow	
		m ³ /h	l/s
HIGH	720	m ³ /h	1470
		l/s	408
		CFM	865
MED	700	m ³ /h	1430
		l/s	397
		CFM	842
LOW	670	m ³ /h	1360
		l/s	378
		CFM	800
QUIET	640	m ³ /h	1300
		l/s	361
		CFM	765

7-2-4. 2-WAY OUTLET MODE

■ MODEL : AU*A36L

● COOLING / HEATING

Fan speed	Number of rotations (r.p.m)	Air flow	
		m ³ /h	l/s
HIGH	720	m ³ /h	1120
		l/s	311
		CFM	659
MED	690	m ³ /h	1070
		l/s	297
		CFM	630
LOW	660	m ³ /h	1020
		l/s	283
		CFM	600
QUIET	640	m ³ /h	990
		l/s	275
		CFM	583

■ MODEL : AU*A45L

● COOLING / HEATING

Fan speed	Number of rotations (r.p.m)	Air flow	
		m ³ /h	l/s
HIGH	720	m ³ /h	1120
		l/s	311
		CFM	659
MED	700	m ³ /h	1090
		l/s	303
		CFM	641
LOW	670	m ³ /h	1040
		l/s	289
		CFM	612
QUIET	640	m ³ /h	990
		l/s	275
		CFM	583

7-3. DUCT CONNECTION

MODEL : AU*A36L, AU*A45L

OUTLET AIR

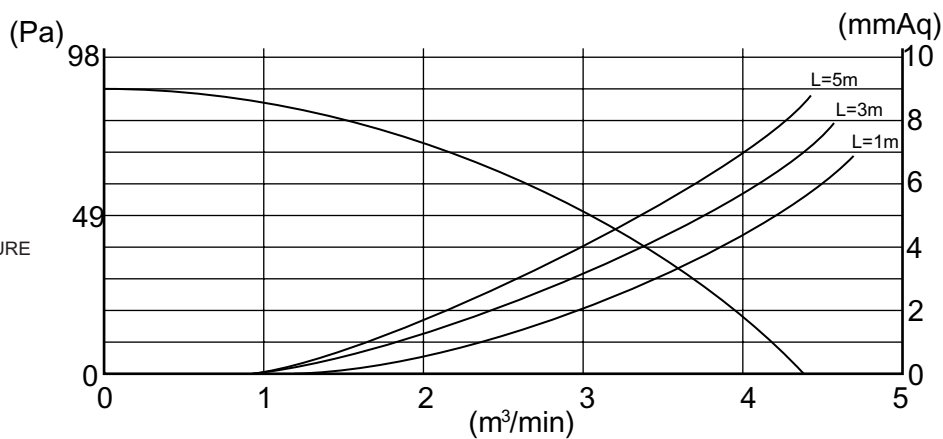
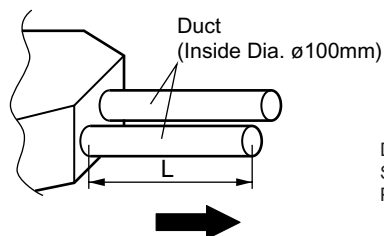
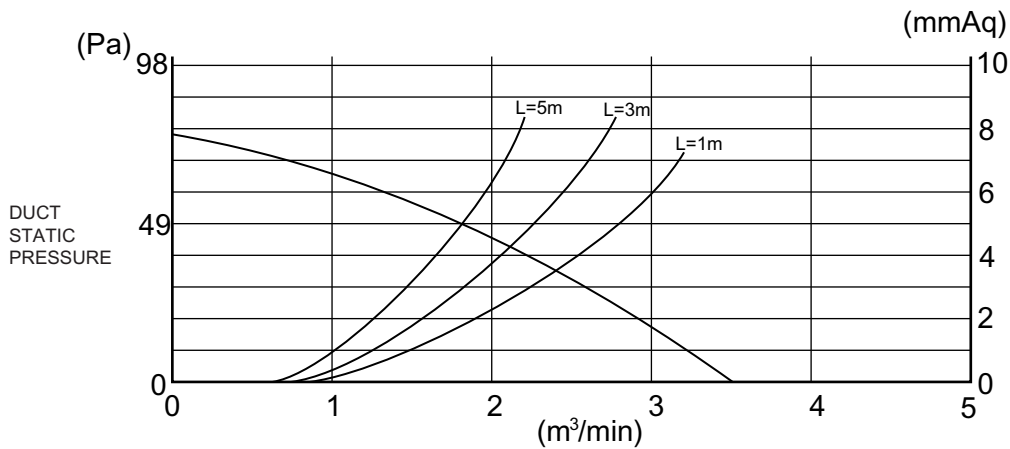
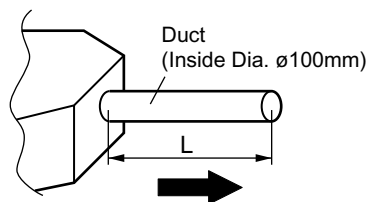

FRESH AIR

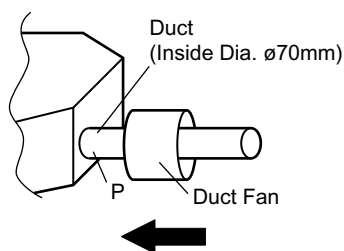

Static pressure required to take in fresh air

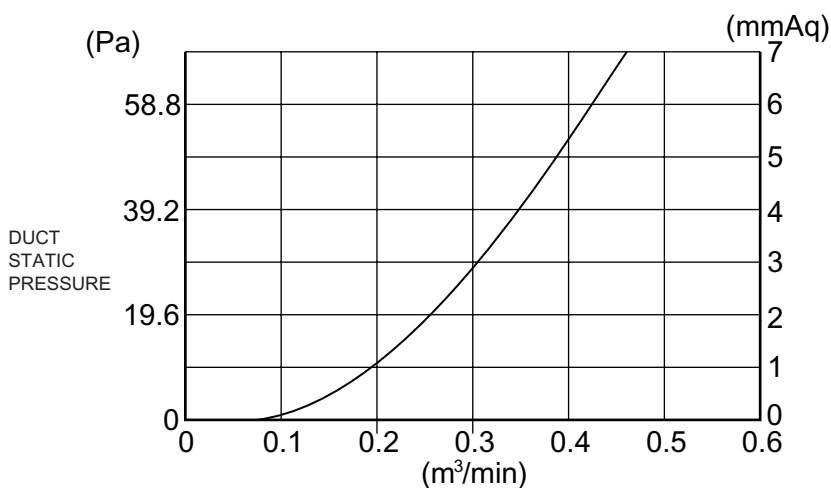

8. OPERATION NOISE

8-1. NOISE LEVEL CURVE

Condition
Ceiling mode : Standard
Air outlet : 4-way air outlet

COOLING

MODEL : AU*A36L

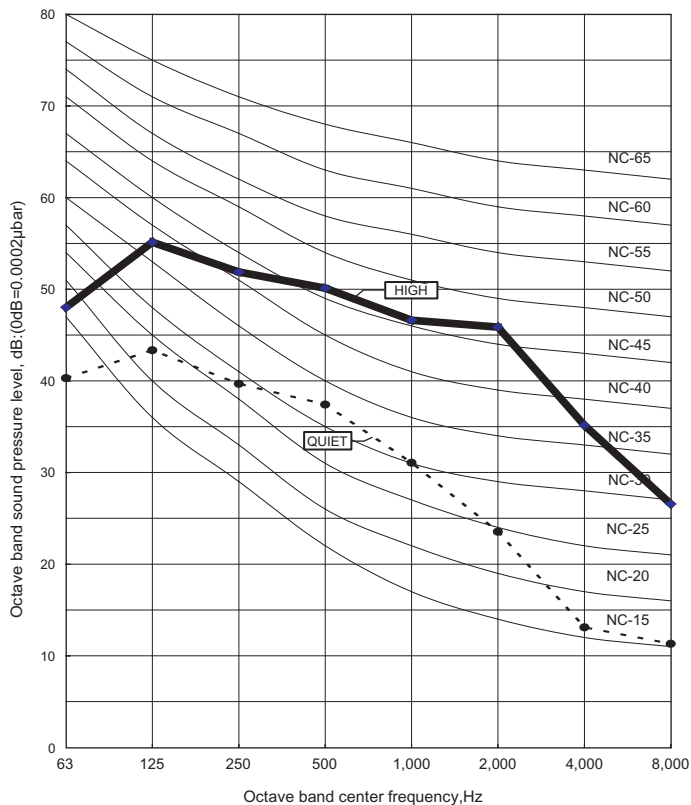

MODEL : AU*A45L

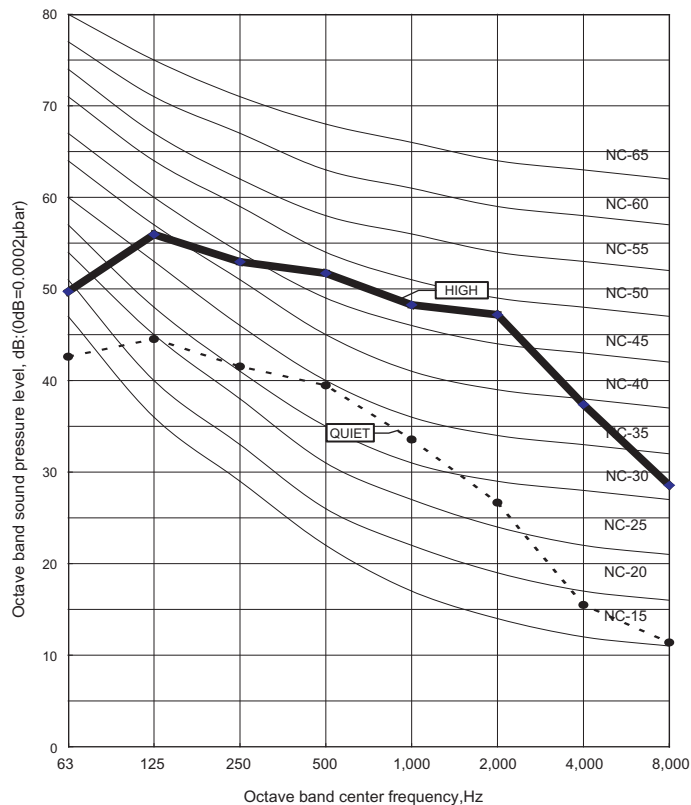

HEATING

MODEL : AU*A36L

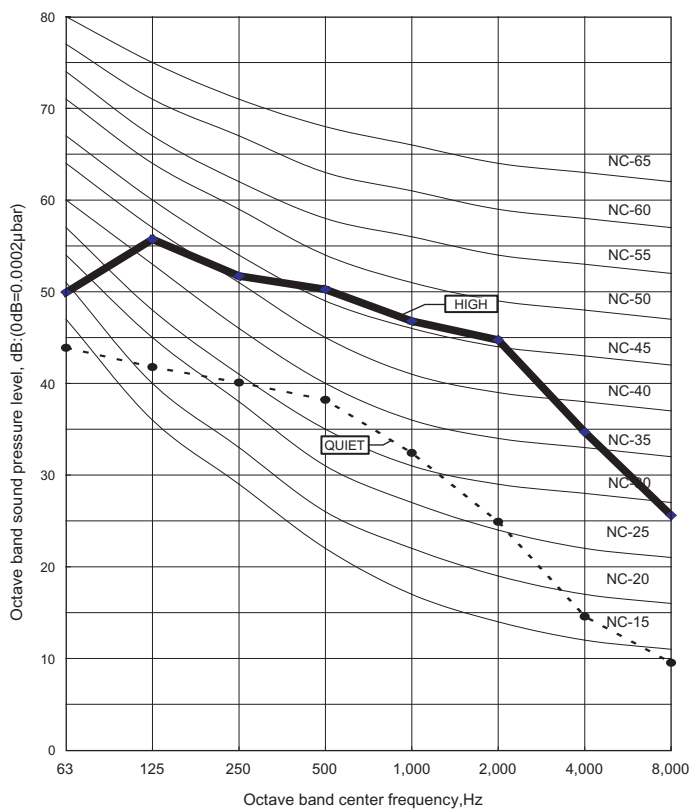

MODEL : AU*A45L

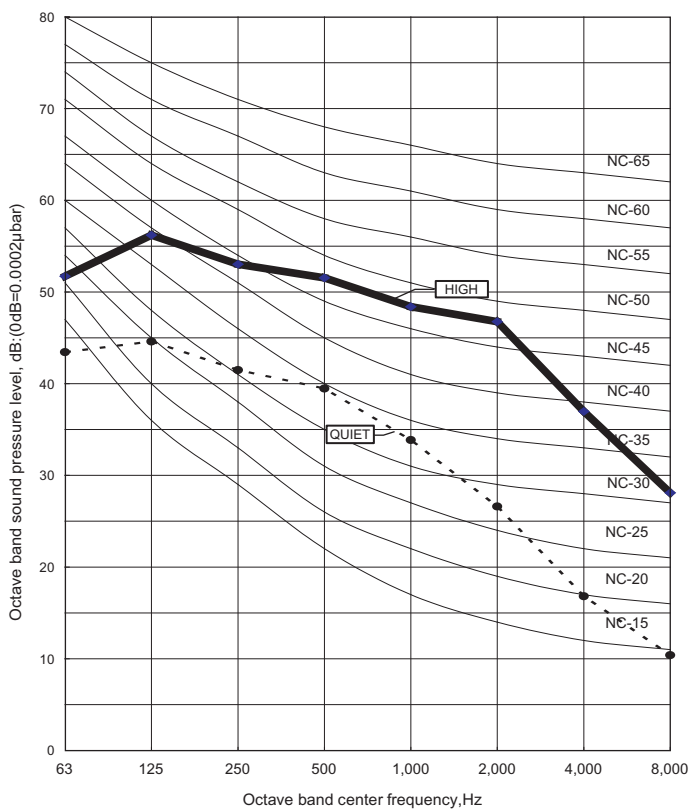

8-2. SOUND LEVEL CHECK POINT

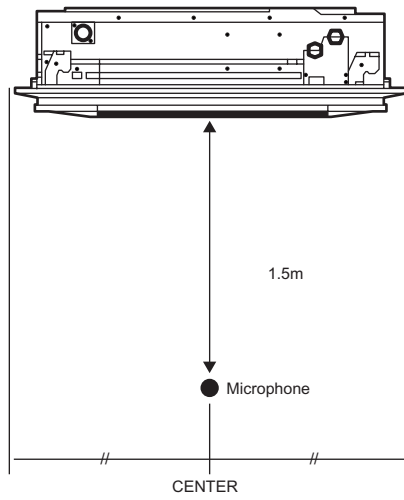
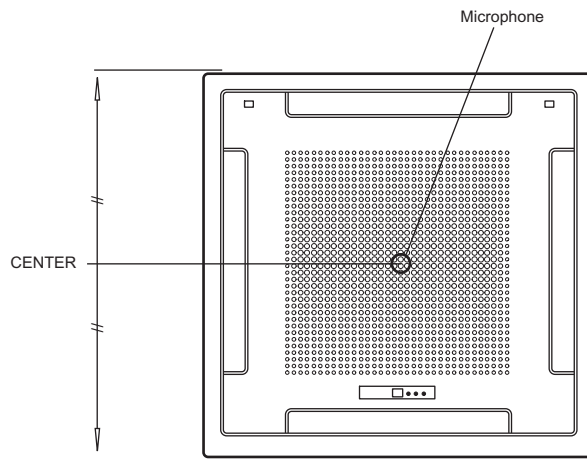

9. ELECTRIC CHARACTERISTICS

Model name			AU * A36L	AU * A45L
Power supply	Voltage	V	230~	
	Frequency	Hz	50	
Max. operating current (Indoor unit)		A	0.7	
Wiring spec. (Indoor unit to outdoor unit)	Connection cable	mm ²	1.5-2.5	
	Limited wiring length	m	51	

10. SAFETY DEVICES

	Protection form	Model	
		AU * A36L	AU * A45L
Circuit protection	Current fuse (PCB)	3.15A 250V	
Fan motor protection	Thermal protection program	139±15°C OFF 109±19°C ON	

11. OPTIONAL PARTS

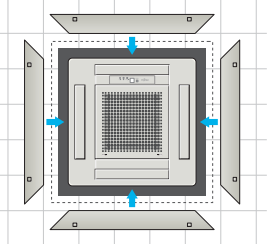
Exterior	Parts name	Model No.	Summary
	Wireless remote controller	UTB- *NA	Unit control is performed by wireless remote controller
	Additional grille	UTG-AGEA-W	The additional grille hides the gap between the ceiling hole and the outlet grille

OUTDOOR UNIT

2. SINGLE TYPE :

AO * A36LATL

AO * A45LATL

1. SPECIFICATIONS

Type			INVERTER HEATPUMP		
Model name			AO * A36LATL	AO * A45LATL	
Power source			230V~ 50Hz		
Available voltage range			198-264V~ 50Hz		
Starting current		A	15.0	15.0	
Fan	Airflow rate	Cooling	m ³ /h	6600	
		Heating		6600	
	Type × Q'ty		Propeller × 2		
Motor output		W	103 × 2	103 × 2	
Sound pressure level	Cooling		dB(A)	54	
	Heating			55	
Heat exchanger type	Dimensions (H × W × D)		mm	1260 × 900 × 36.4	
	Fin pitch			1.30	
	Rows x Stages		2 × 60	2 × 60	
	Pipe type		Copper		
	Fin type		Aluminium		
Compressor	Type × Q'ty		Twin Rotary × 1		
	Motor output		W	3750	
Refrigerant	Type		R410A		
	Charge	g	3350		
Refrigerant oil	Type		POE		
Enclosure	Material		Steel sheet		
	Colour		Beige (10YR7.5/1.0NN)		
Dimensions (H × W × D)	Net		mm	1290 × 900 × 330	
	Gross			1430 × 1050 × 445	
Weight	Net		kg(lb.)	98 (216)	
	Gross			107 (236)	
Connection pipe	Size	Liquid	mm	φ 9.52 (φ 3/8 in.)	
		Gas		φ 15.88 (φ 5/8 in.)	
	Method		Flare		
	Max. length		m	50 (chargeless : 20)	50 (chargeless : 20)
Max. height difference		30		30	
Operation range	Cooling		°C	-15 to 46	
	Heating			-15 to 24	

Note :

Specifications are based on the following conditions.

Cooling : Indoor temperature of 27°CDB/19°CWB. and outdoor temperature of 35°CDB/24°CWB.

Heating : Indoor temperature of 20°CDB/15°CWB. and outdoor temperature of 7°CDB/6°CWB.

Pipe length : 7.5 m, Height difference : 0 m. (Outdoor unit - Indoor unit)

2. DIMENSIONS

■ MODEL : AO*A36L, AO*A45L

(Unit : mm)

OUTDOOR UNIT
AO*A36-45L

OUTDOOR UNIT
AO*A36-45L

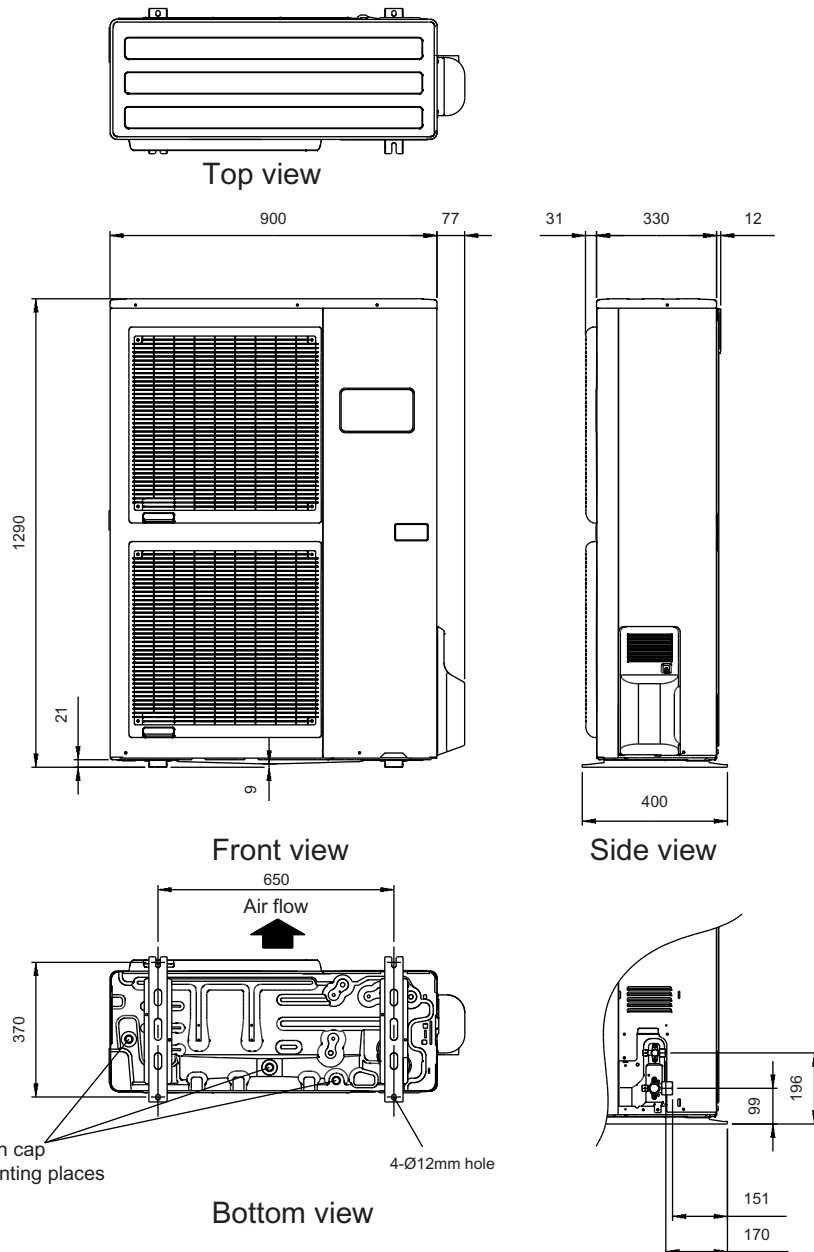

■ MOUNTING POSITION

When there are obstacles at the back or front side.

When there are obstacles at the back and front sides.

When there are obstacles at the back, side(s), and top.

When there are obstacles at the back side with the installation of more than one unit.

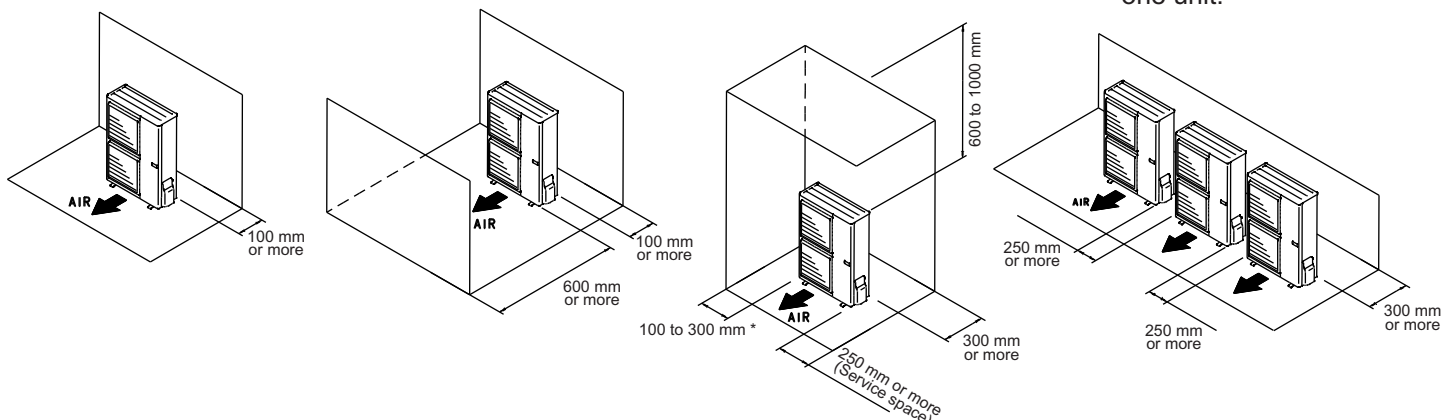

* If the space is larger than that is stated, the condition will be the same as that there are no obstacles.

3. REFRIGERANT CIRCUIT

■ MODEL : AO*A36L, AO*A45L

OUTDOOR UNIT
AO*A36-45L

OUTDOOR UNIT
AO*A36-45L

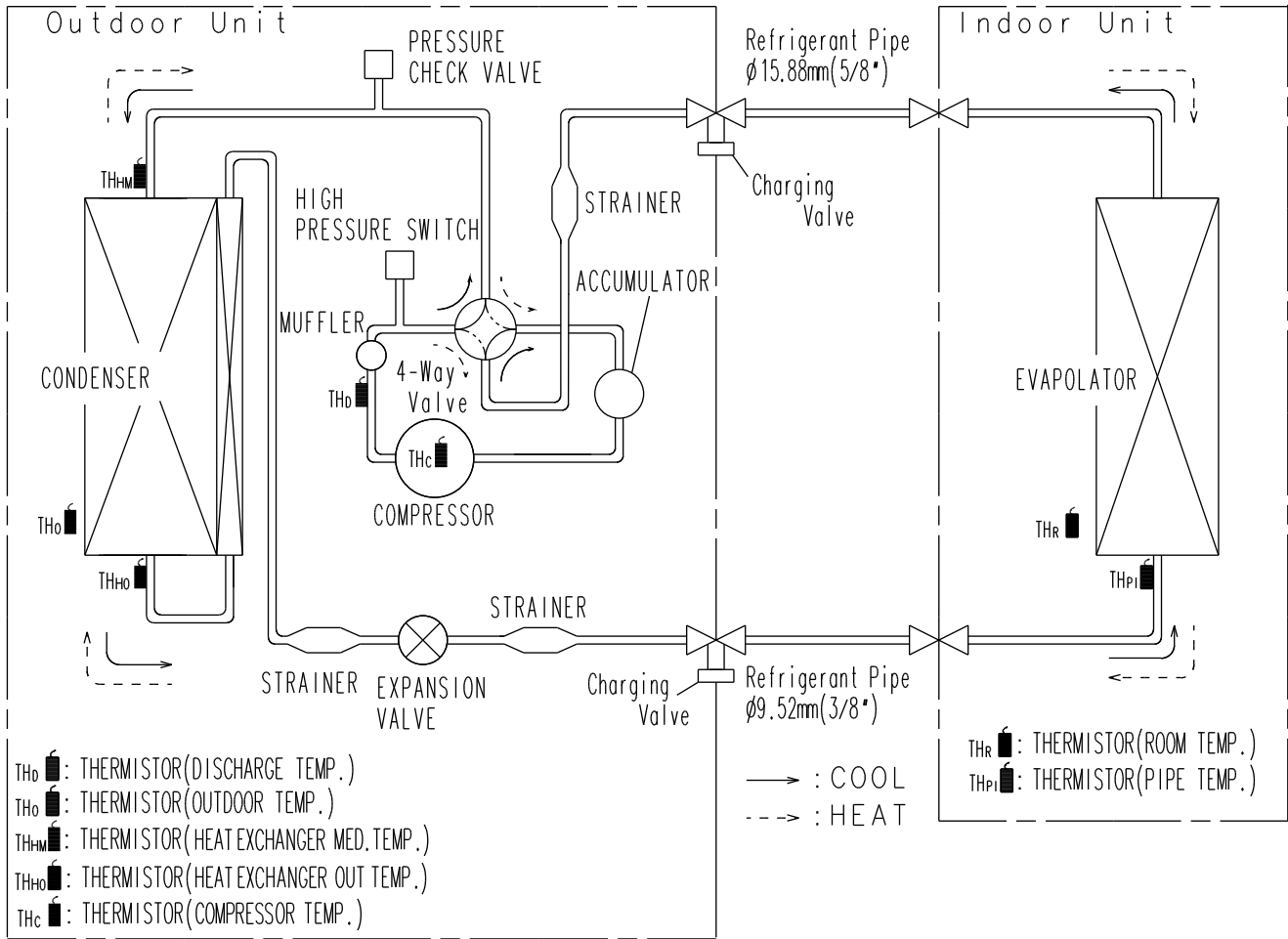

4. WIRING DIAGRAMS

■ MODEL : AO *A36L, AO *A45L

OUTDOOR UNIT
AO*A36-45L

OUTDOOR UNIT
AO*A36-45L

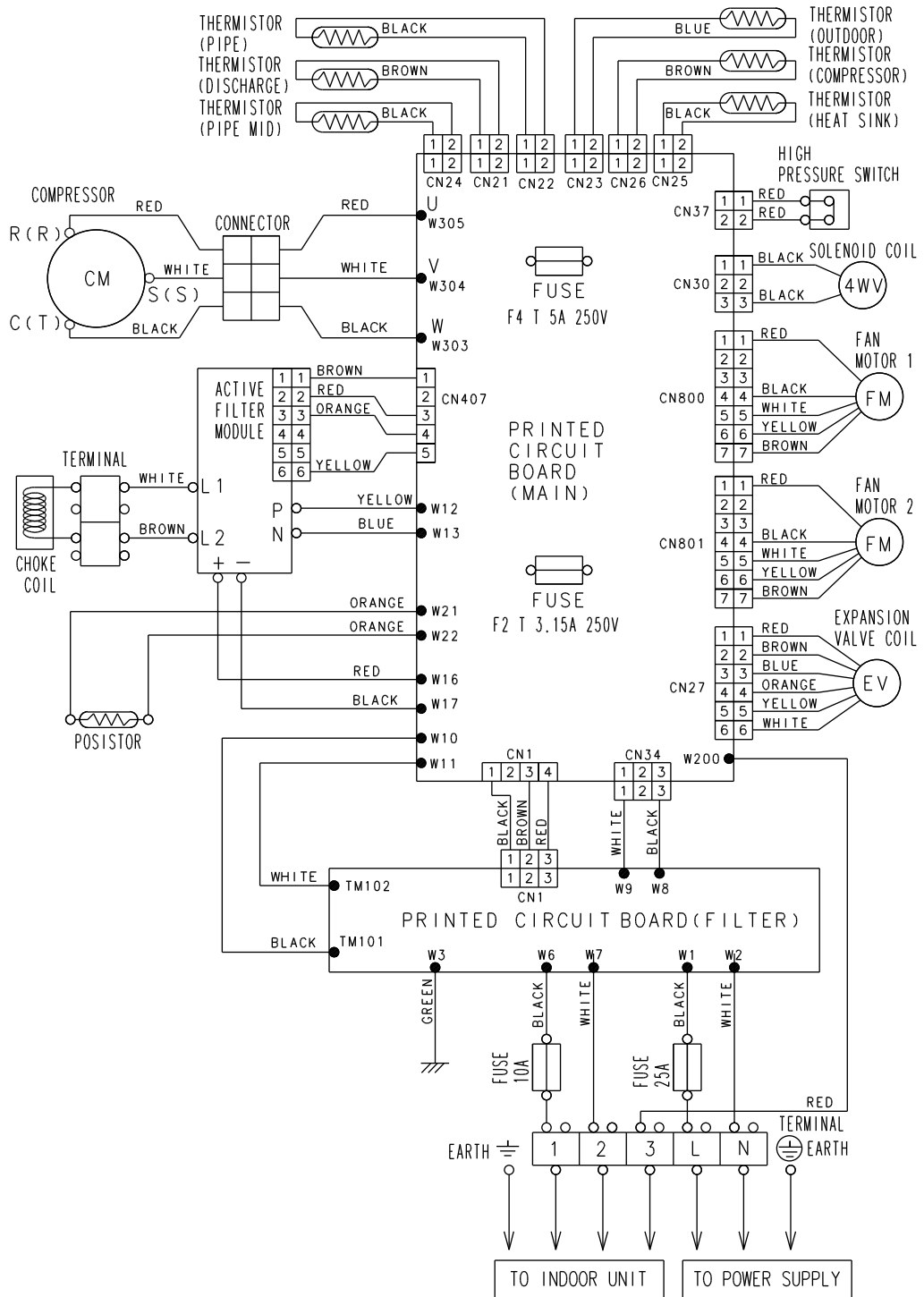

5. COEFFICIENT OF COMPENSATION FOR PIPE LENGTH AND HEIGHT DIFFERENCE

This table is created using the maximum capacity.

■ MODEL : AO*A36L

OUTDOOR UNIT
AO*A36-45L

OUTDOOR UNIT
AO*A36-45L

COOLING			Pipe length (m)						
			5	7.5	10	20	30	40	50
Height difference H (m)	* 1 Indoor unit is upper than outdoor unit.	30	-	-	-	-	0.884	0.881	0.862
		20	-	-	-	0.910	0.899	0.896	0.876
		10	-	-	0.969	0.925	0.914	0.911	0.890
		7.5	-	0.988	0.973	0.929	0.918	0.914	0.894
		5	1.001	0.992	0.977	0.932	0.921	0.918	0.898
	0	1.009	1.000	0.985	0.940	0.929	0.926	0.905	
	* 2 Indoor unit is under than outdoor unit	-5	1.009	1.000	0.985	0.940	0.929	0.926	0.905
		-7.5	-	1.000	0.985	0.940	0.929	0.926	0.905
		-10	-	-	0.985	0.940	0.929	0.926	0.905
		-20	-	-	-	0.940	0.929	0.926	0.905
-30		-	-	-	-	0.929	0.926	0.905	

HEATING			Pipe length (m)						
			5	7.5	10	20	30	40	50
Height difference H (m)	* 1 Indoor unit is upper than outdoor unit.	30	-	-	-	-	0.971	0.950	0.927
		20	-	-	-	0.985	0.971	0.950	0.927
		10	-	-	1.016	0.985	0.971	0.950	0.927
		7.5	-	1.000	1.016	0.985	0.971	0.950	0.927
		5	0.978	1.000	1.016	0.985	0.971	0.950	0.927
	0	0.978	1.000	1.016	0.985	0.971	0.950	0.927	
	* 2 Indoor unit is under than outdoor unit	-5	0.973	0.995	1.011	0.980	0.966	0.945	0.923
		-7.5	-	0.993	1.009	0.978	0.963	0.943	0.920
		-10	-	-	1.006	0.975	0.961	0.940	0.918
		-20	-	-	-	0.966	0.951	0.931	0.909
-30		-	-	-	-	0.942	0.921	0.899	

Height difference H

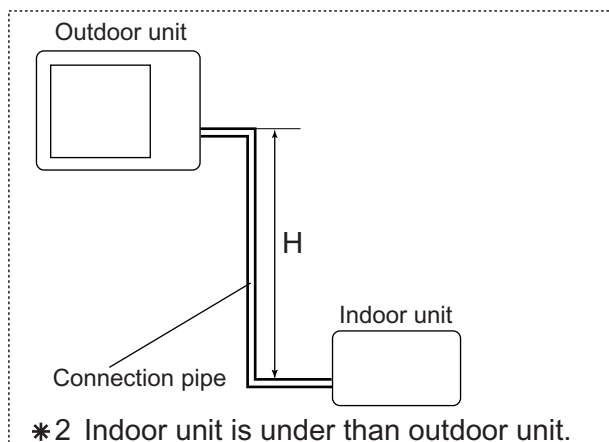
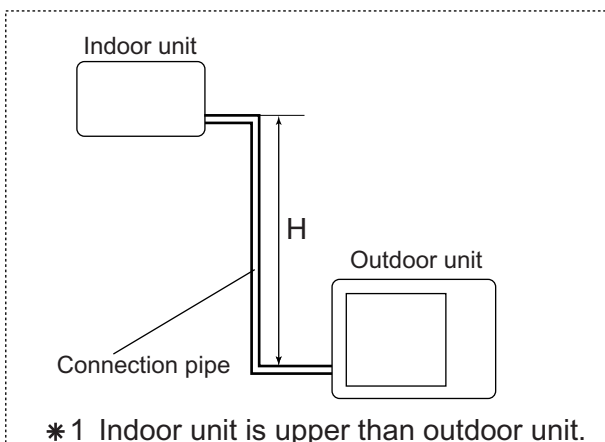

This table is created using the maximum capacity.

■ **MODEL : AO*A45L**

OUTDOOR UNIT
AO*A36-45L

OUTDOOR UNIT
AO*A36-45L

COOLING			Pipe length (m)						
			5	7.5	10	20	30	40	50
Height difference H (m)	* 1 Indoor unit is upper than outdoor unit.	30	-	-	-	-	0.893	0.890	0.870
		20	-	-	-	0.919	0.908	0.905	0.885
		10	-	-	0.979	0.934	0.923	0.920	0.899
		7.5	-	0.988	0.983	0.938	0.927	0.924	0.903
		5	1.001	0.992	0.987	0.942	0.931	0.927	0.907
	0	1.009	1.000	0.995	0.949	0.938	0.935	0.914	
	* 2 Indoor unit is under than outdoor unit	-5	1.009	1.000	0.995	0.949	0.938	0.935	0.914
		-7.5	-	1.000	0.995	0.949	0.938	0.935	0.914
		-10	-	-	0.995	0.949	0.938	0.935	0.914
		-20	-	-	-	0.949	0.938	0.935	0.914
-30		-	-	-	-	0.938	0.935	0.914	

HEATING			Pipe length (m)						
			5	7.5	10	20	30	40	50
Height difference H (m)	* 1 Indoor unit is upper than outdoor unit.	30	-	-	-	-	0.971	0.950	0.927
		20	-	-	-	0.985	0.971	0.950	0.927
		10	-	-	1.016	0.985	0.971	0.950	0.927
		7.5	-	1.000	1.016	0.985	0.971	0.950	0.927
		5	0.978	1.000	1.016	0.985	0.971	0.950	0.927
	0	0.978	1.000	1.016	0.985	0.971	0.950	0.927	
	* 2 Indoor unit is under than outdoor unit	-5	0.973	0.995	1.011	0.980	0.966	0.945	0.923
		-7.5	-	0.993	1.009	0.978	0.963	0.943	0.920
		-10	-	-	1.006	0.975	0.961	0.940	0.918
		-20	-	-	-	0.966	0.951	0.931	0.909
-30		-	-	-	-	0.942	0.921	0.899	

Height difference H

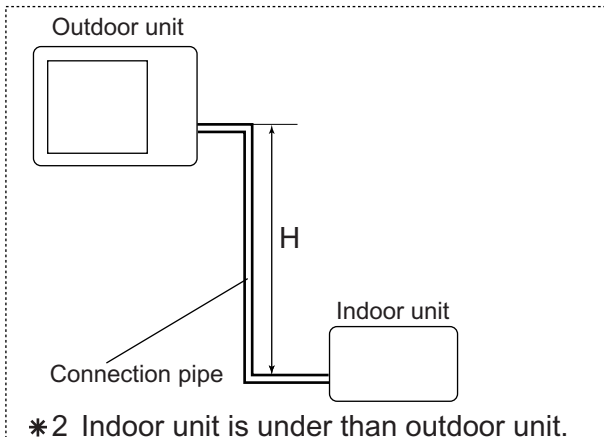
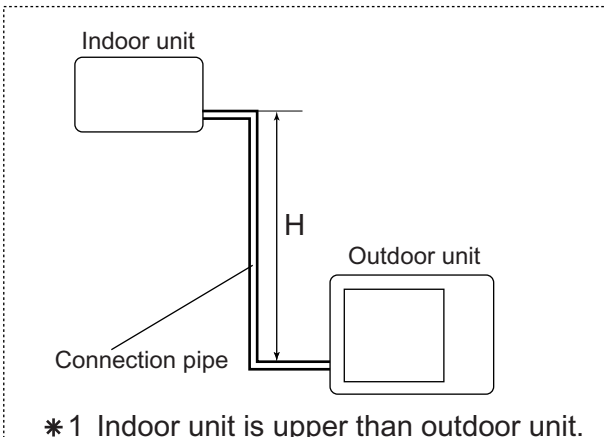

6. ADDITIONAL CHARGE CALCULATION

■ MODEL : AO*A36L, AO*A45L

Refrigerant type	R410A	
Refrigerant amount	g	3350

● REFRIGERANT CHARGE

Pipe length	m	~ 20	30	40	50	50g/m
Additional charge	g	0 (Chargeless)	+500	+1000	+1500	

7. AIR FLOW

■ MODEL : AO *A36L, AO *A45L

● COOLING

	Number of rotations (r.p.m)	Air flow	
Upper fan	850	m ³ /h	6600
		l/s	1833
Lower fan	750	CFM	3884

● HEATING

	Number of rotations (r.p.m)	Air flow	
Upper fan	850	m ³ /h	6600
		l/s	1833
Lower fan	750	CFM	3884

8. OPERATION NOISE

8-1. NOISE LEVEL CURVE

■ COOLING

● MODEL : AO*A36L

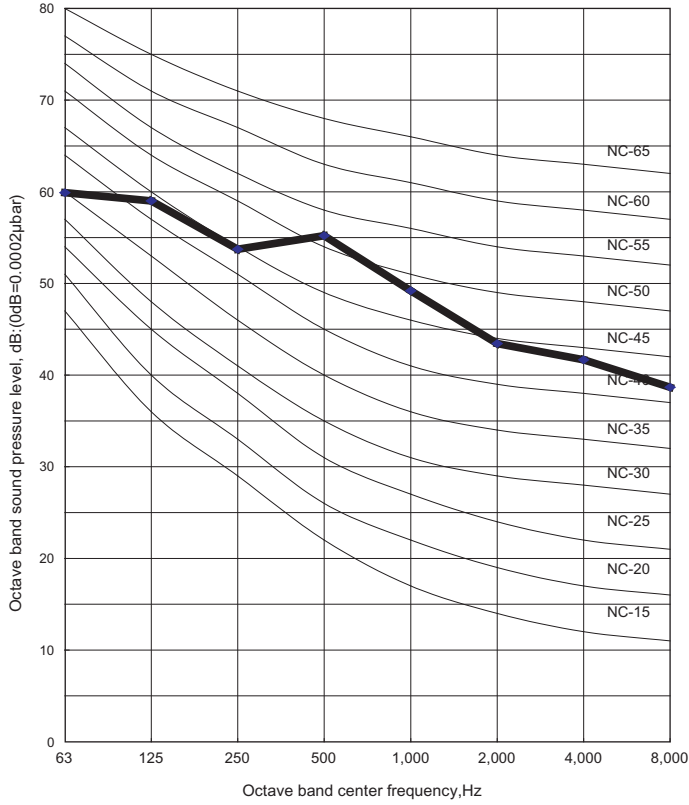

● MODEL : AO*A45L

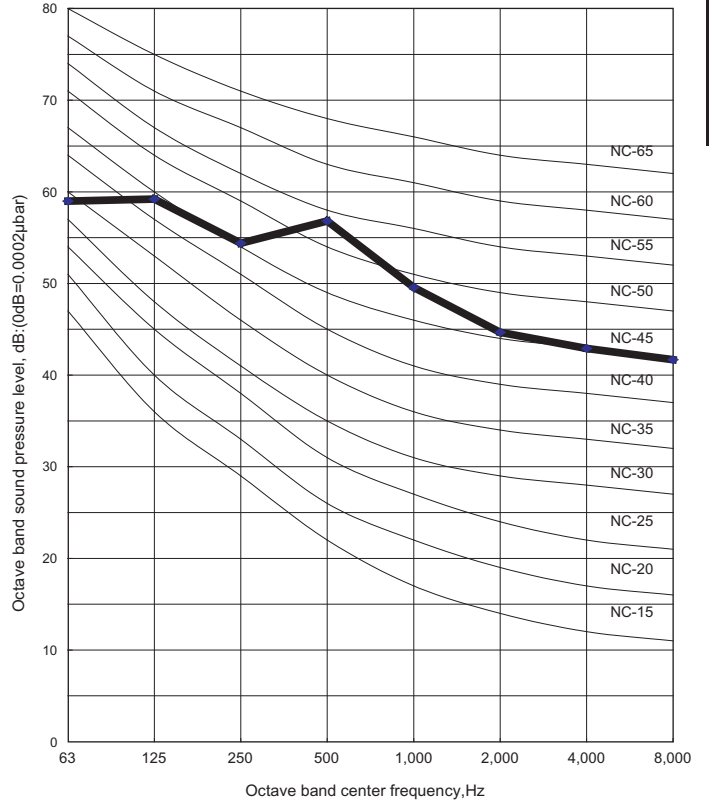

■ HEATING

● MODEL : AO*A36L

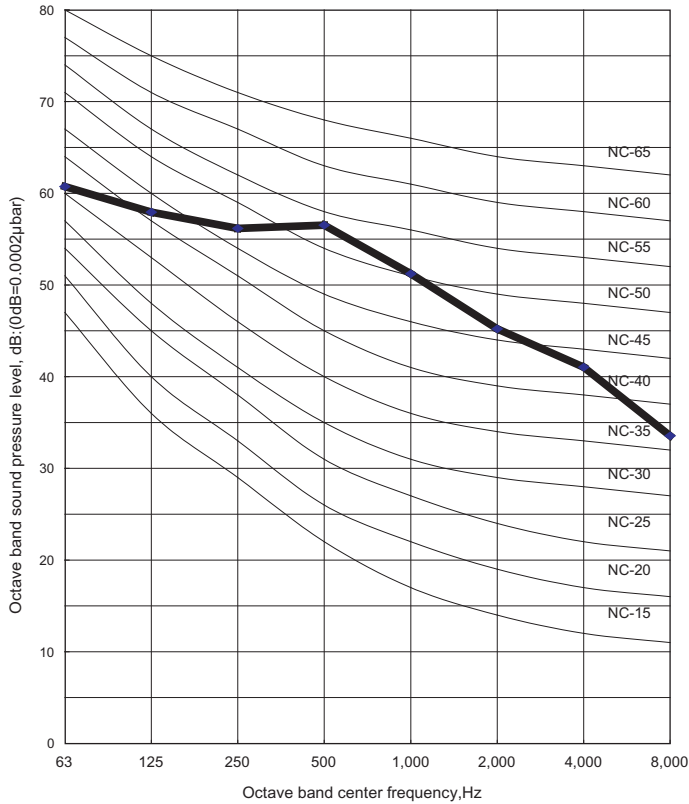

● MODEL : AO*A45L

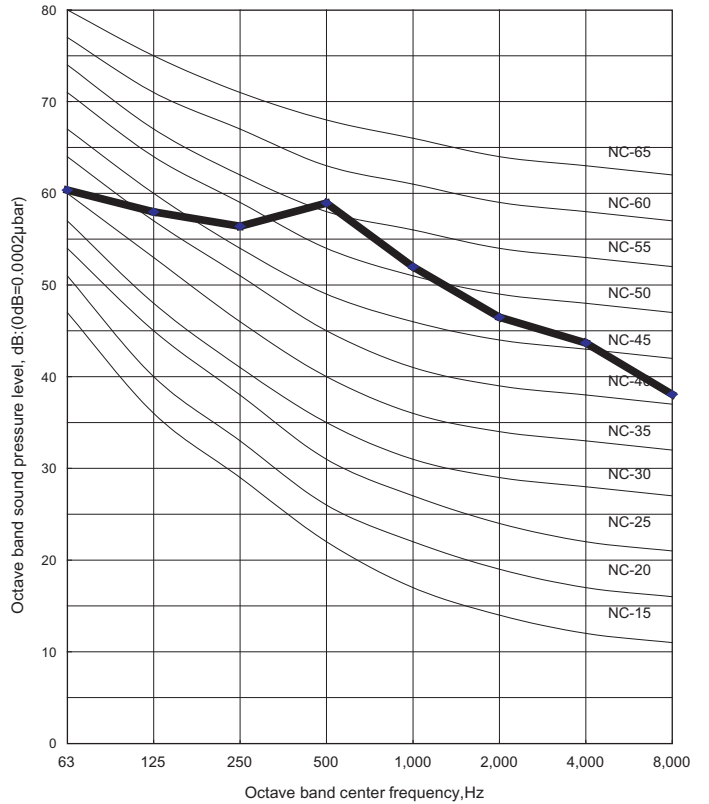

OUTDOOR UNIT
AO*A36-45L

OUTDOOR UNIT
AO*A36-45L

8-2. SOUND LEVEL CHECK POINT

OUTDOOR UNIT
AO*A36-45L

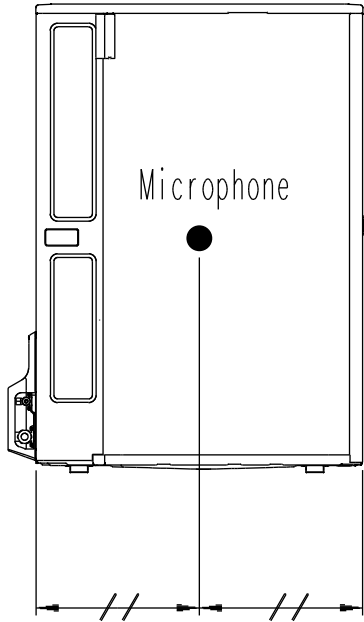
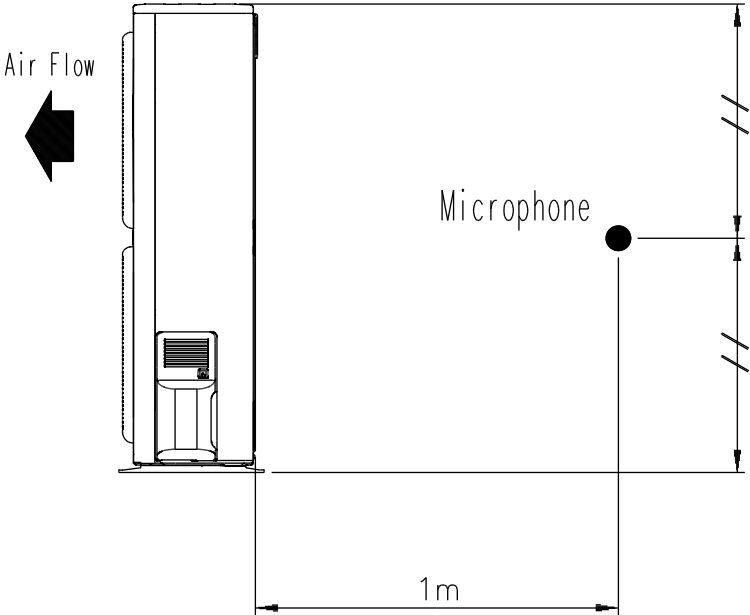

OUTDOOR UNIT
AO*A36-45L

9. ELECTRIC CHARACTERISTICS

Model Name			AO * A36L	AO * A45L
Power Supply	Voltage	V	230~	
	Frequency	Hz	50	
Max. Operating Current		A	19.0	20.0
Starting Current		A	15.0	
*1) Wiring Spec.	Main Fuse (Circuit breaker) Current	A	30	
	Power Cable	mm ²	5.3 - 6.0	
	*2)Limited wiring length	m	17	

*1) Wiring Spec. :

Selected Sample

(Selected based on Japan Electrotechnical Standard and Codes Committee E0005)

*2) Limited Wiring length :

This is the wiring length in case voltage descent is less than 2%.

When the wiring length becomes long, please select the wiring of a more larger diameter.

10. SAFETY DEVICES

	Protection form	Model	
		AO * A36L	AO * A45L
Circuit protection	Current fuse (NEAR THE TERMINAL)	25A 250V	
	Current fuse (NEAR THE TERMINAL)	10A 250V	
	Current fuse (MAIN PRINTED CIRCUIT BOARD)	5A 250V	
	Current fuse (MAIN PRINTED CIRCUIT BOARD)	3.15A 250V	
Fan motor protection	Thermal protection program	OFF : 130±20°C ON : 100±20°C	
High Pressure Protection	High Pressure Switch	OFF : 4.2±0.1MPa ON : 3.2±0.15MPa	
Compressor protection	Thermal protection program (COMPRESSOR TEMP.)	OFF : 110°C ON : 80°C	
	Thermal protection program (DISCHARGE TEMP.)	OFF : 115°C ON : After 7 minutes	

OUTDOOR UNIT
AO*A36-45L

OUTDOOR UNIT
AO*A36-45L

REMOTE CONTROLLER

4. WIRELESS REMOTE CONTROLLER : UTB - *NA

FEATURES



- * Four kinds of timer setup (ON / OFF / PROGRAM / SLEEP) are possible.
- * Four kinds of timers. Easy operation.
- * Easy to change transmission code (4 patterns) by button operation.

● Simple function setting

Setting of the air conditioner selection function is performed by remote controller.

● Built-in timers

Select from four different timer programs (On/Off/Program/Sleep).

● Program timer

The program timer operates the ON and OFF timer once within a 24 hour period.

● Sleep timer

The sleep timer function automatically corrects the temperature thermostat setting according to the time setting to prevent excessive cooling and heating while sleeping.

Cooling operation/dry operation

When the sleep timer is set, the set temperature automatically rises 1°C every hour. The set temperature can rise up to a maximum of 2°C.

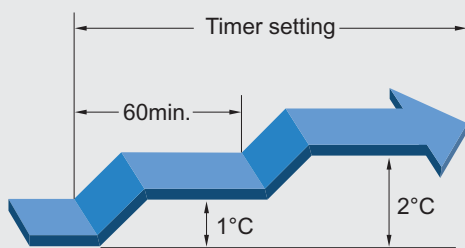

Heating operation

When the sleep timer is set, the set temperature automatically drops 1°C every 30 minutes. The set temperature can drop to a maximum of 4°C.

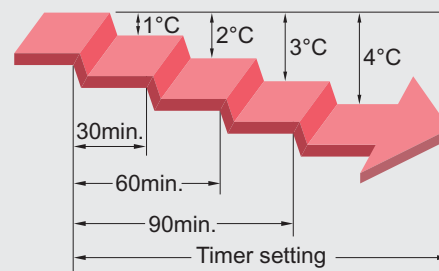

● Simultaneously operation

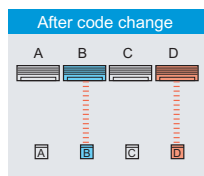
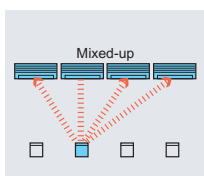

- Code selector switch eliminates unit being wrongly switched. (Up to 4 codes can be set.)

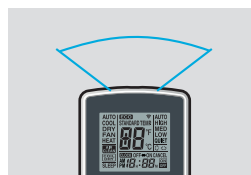

- Wide and precise transmitting range.

1. Press the MODE button for more than five seconds to start the code change.
2. Press the ▲ or ▼ button to select the desired code.
 A → B → C → D
3. Press the MODE button again to end the code change.

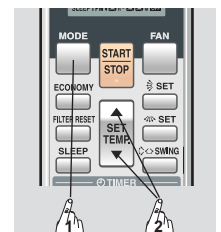

FUNCTIONS

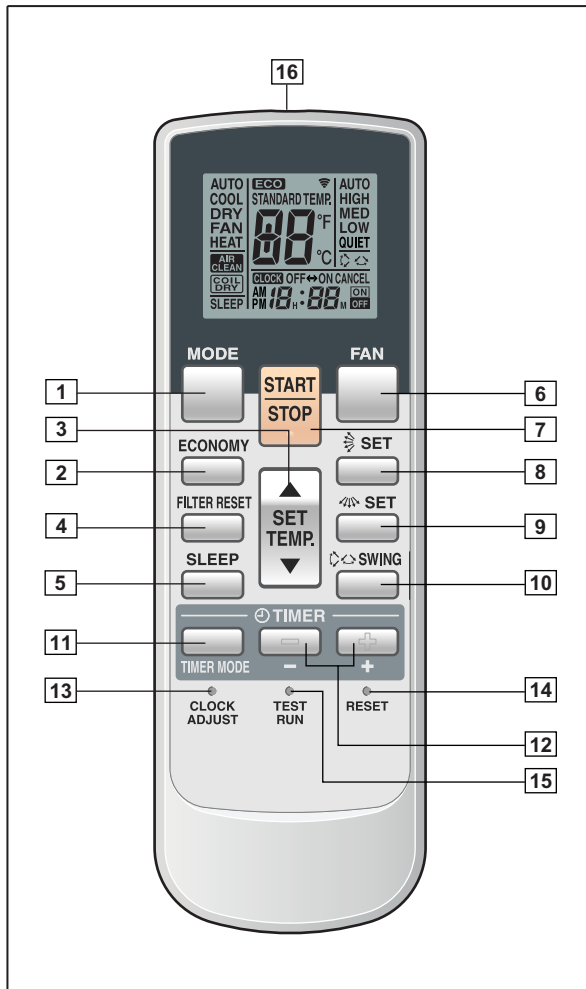

- 1 **MODE button**
Selects the operating mode (AUTO, HEAT, FAN, COOL, DRY). /Start / end R.C. custom code change. (Max 4 types)
- 2 **Economy button**
- 3 **Set temp. button (▲/▼)**
Set remote controller custom code buttons
Sets the indoor temp./ Sets R.C. custom code.
- 4 **Filter reset button**
- 5 **Sleep button**
Pressed to select sleep timer.
- 6 **Fan button**
Selects the fan speed (AUTO, QUIET, LOW, MED, HIGH).
- 7 **START/STOP button**
Pressed to start and stop operation.
- 8 **Set button (Vertical)**
Air flow direction vertical set button.
- 9 **Set button (Horizontal)**
Air flow direction horizontal set button.
- 10 **Swing button**
Air flow direction swing button.
- 11 **Timer mode button**
Pressed to select the timer mode. (OFF TIMER, ON TIMER, PROGRAM TIMER, TIMER RESET)
- 12 **Timer set () / () button**
Sets the current time and on-off time.
- 13 **Clock adjust button**
Sets the current time.
- 14 **Reset button**
Used when replacing batteries.
- 15 **Test run button**
Used when testing the air conditioner after installation.

Display panel

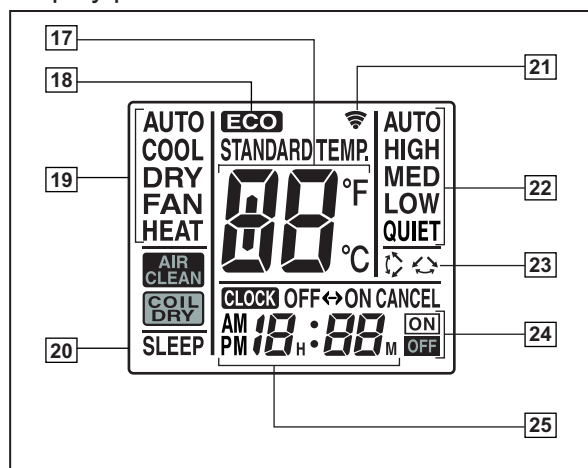

- 16 **Signal transmitter**
- 17 **Temperature set display**
- 18 **Economy display**
- 19 **Operating mode display**
- 20 **Sleep display**
- 21 **Transmit indicator**
- 22 **Fan speed display**
- 23 **Swing display**
- 24 **Timer mode display**
- 25 **Clock display**

SPECIFICATION

SIZE (H x W x D mm)	170 x 56 x 19
WEIGHT (g)	80
ACCESSORY	Holder