



**SPLIT TYPE
ROOM AIR CONDITIONER
WALL MOUNTED type**

SERVICE MANUAL



Models

Indoor unit

Outdoor unit

ASHB24LDC

AOHS24LDC

CONTENTS

SPECIFICATIONS.....	1
DIMENSIONS.....	2
REFRIGERANT SYSTEM DIAGRAM	3
CIRCUIT DIAGRAM	4
INDOOR PCB CIRCUIT DIAGRAM	5
OUTDOOR PCB CIRCUIT DIAGRAM	8
ERROR CONTENTS	13
DISASSEMBLY ILLUSTRATION	14
PARTS LIST	20
STANDARD ACCESSORIES	22

SPECIFICATIONS

INDOOR UNIT	ASHB24LDC
OUTDOOR UNIT	AOHS24LDC
COOLING CAPACITY	7.10 kW
HEATING CAPACITY	8.10 kW

ELECTRICAL DATA

POWER SOURCE	230 V	
FREQUENCY	50Hz	
RUNNING CURRENT	COOLING	9.7 A
	HEATING	9.8 A
INPUT WATTS	COOLING	2.21 kW
	HEATING	2.24 kW
E.E.R.	COOLING	3.21 kW/kW
COP	HEATING	3.62 kW/kW
MOISTURE REMOVAL	3.0 L/hr	
AIR CIRCULATION HIGH	1,170 m ³ /hr	

COMPRESSOR

TYPE	Hermetic type, 4 pole, DC inverter motor, Scroll	
DISCRIMINATION	5CS160XAA23	
REFRIGERANT	R410A	1,600 g

FAN MOTOR

POWER SOURCE	230 V	
INDOOR UNIT	HIGH	1,380 r.p.m.
	MED	1,170 r.p.m.
	LOW	980 r.p.m.
	QUIET	860 r.p.m.
OUTDOOR UNIT	COOL	1,000 r.p.m.
	HEAT	1,050 r.p.m.

DIMENSIONS

INDOOR UNIT	H x W x D	320 x 998 x 228 mm
OUTDOOR UNIT	H x W x D	578 x 790 x 315 mm

WEIGHT

INDOOR UNIT	Gross / Net	18 kg / 14 kg
OUTDOOR UNIT	Gross / Net	48 kg / 44 kg

NOISE LEVEL

INDOOR UNIT	HIGH	Cool 49 dB / Heat 48 dB
	MED	Cool 43 dB / Heat 42 dB
	LOW	Cool 38 dB / Heat 37 dB
	QUIET	Cool 33 dB / Heat 33 dB
OUTDOOR UNIT		Cool 52 dB / Heat 54 dB

REFRIGERANT CHARGE (R410A)

FULL CHARGE	Pipe Length	15 m	1,600 g
		20 m	1,700 g
		25 m	1,800 g
		30 m	1,900 g
ADDITIONAL CHARGE			20 g / m

OUTLINE AND DIMENSIONS

Unit : mm

INDOOR UNIT

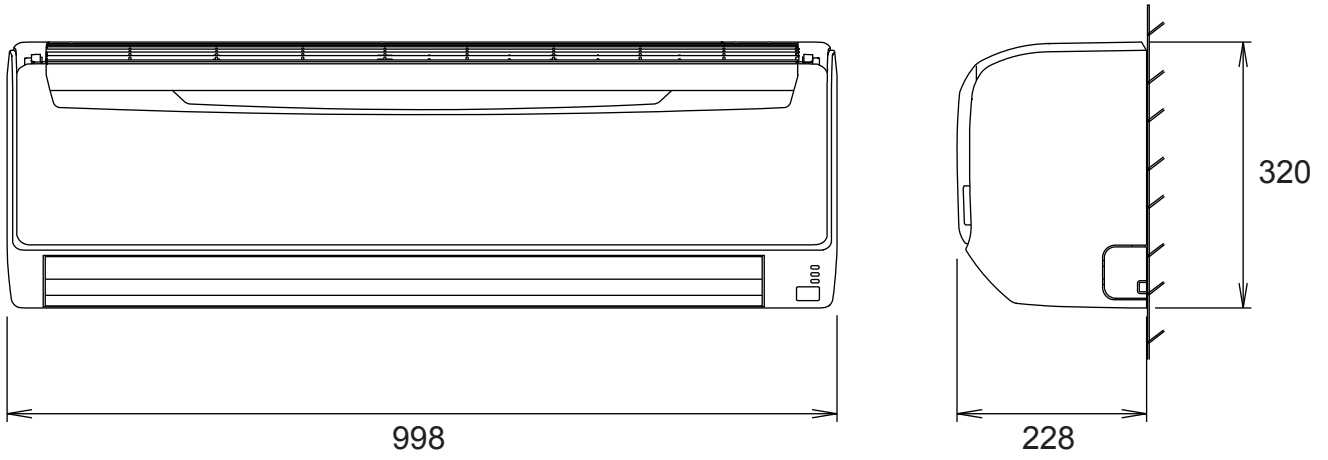

OUTDOOR UNIT

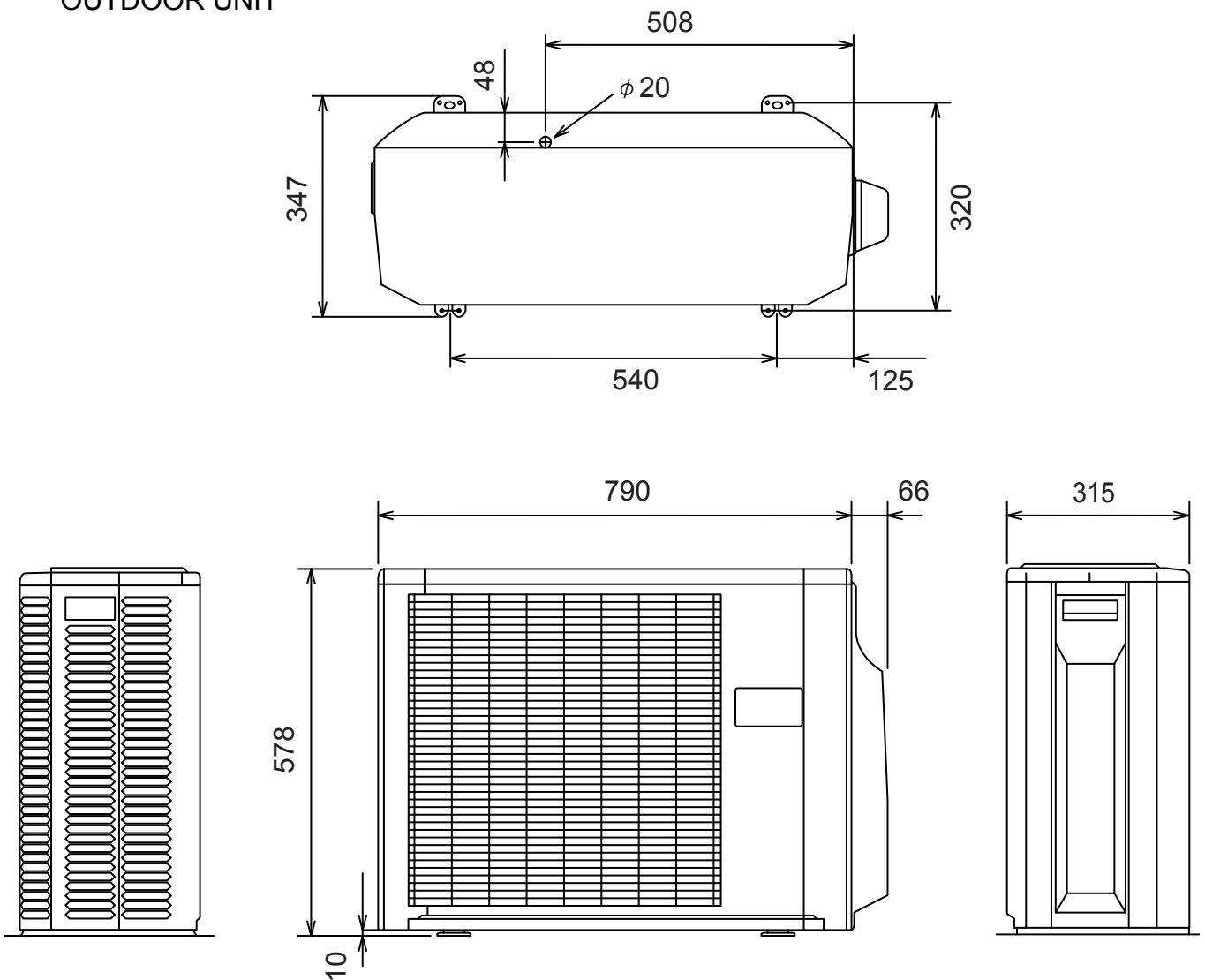

REFRIGERANT SYSTEM DIAGRAM

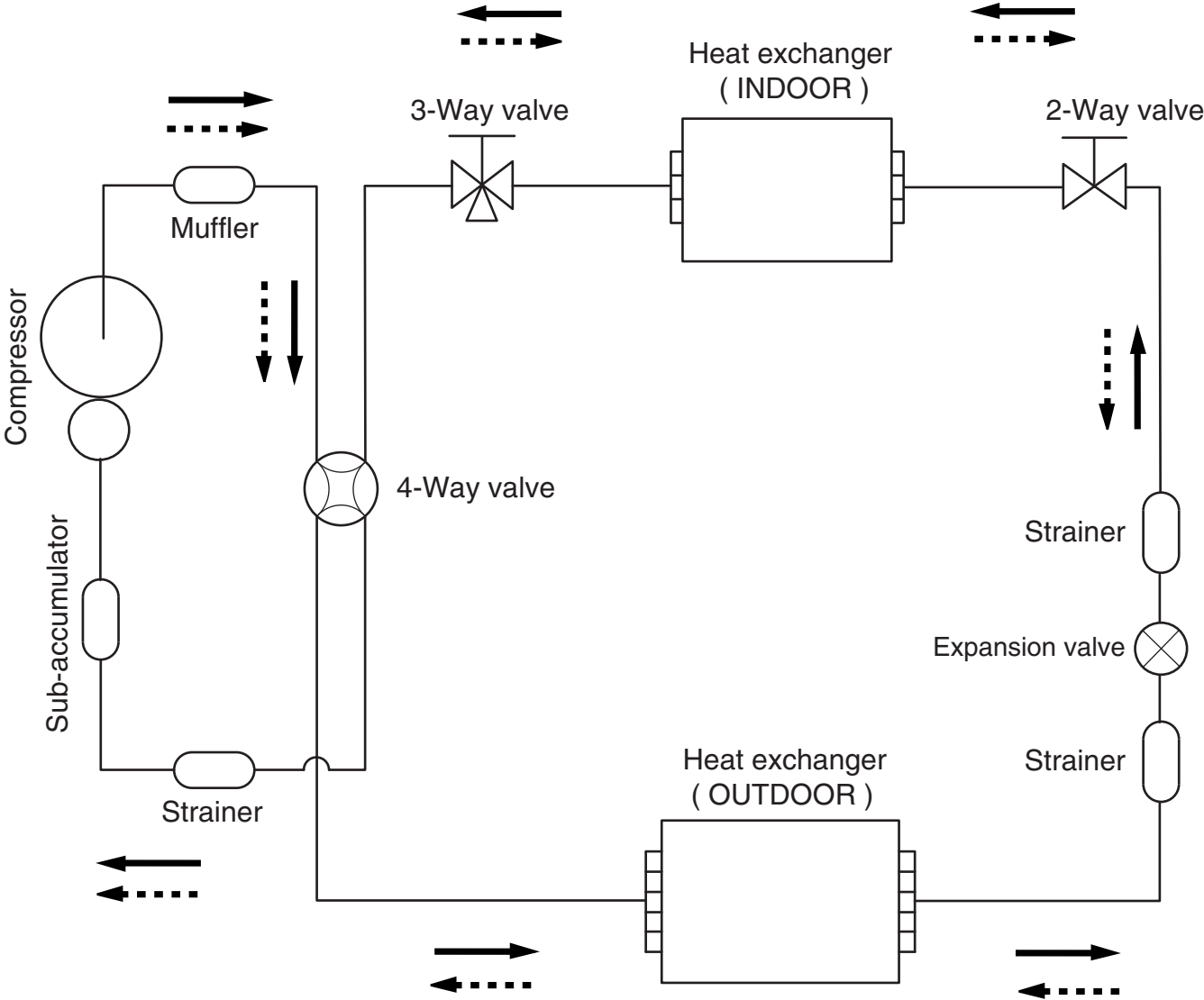

 Cooling
 Heating

Refrigerant pipe diameter
 Liquid : 1/4" (6.35 mm)
 Gas : 5/8" (15.88 mm)

CIRCUIT DIAGRAM

INDOOR UNIT

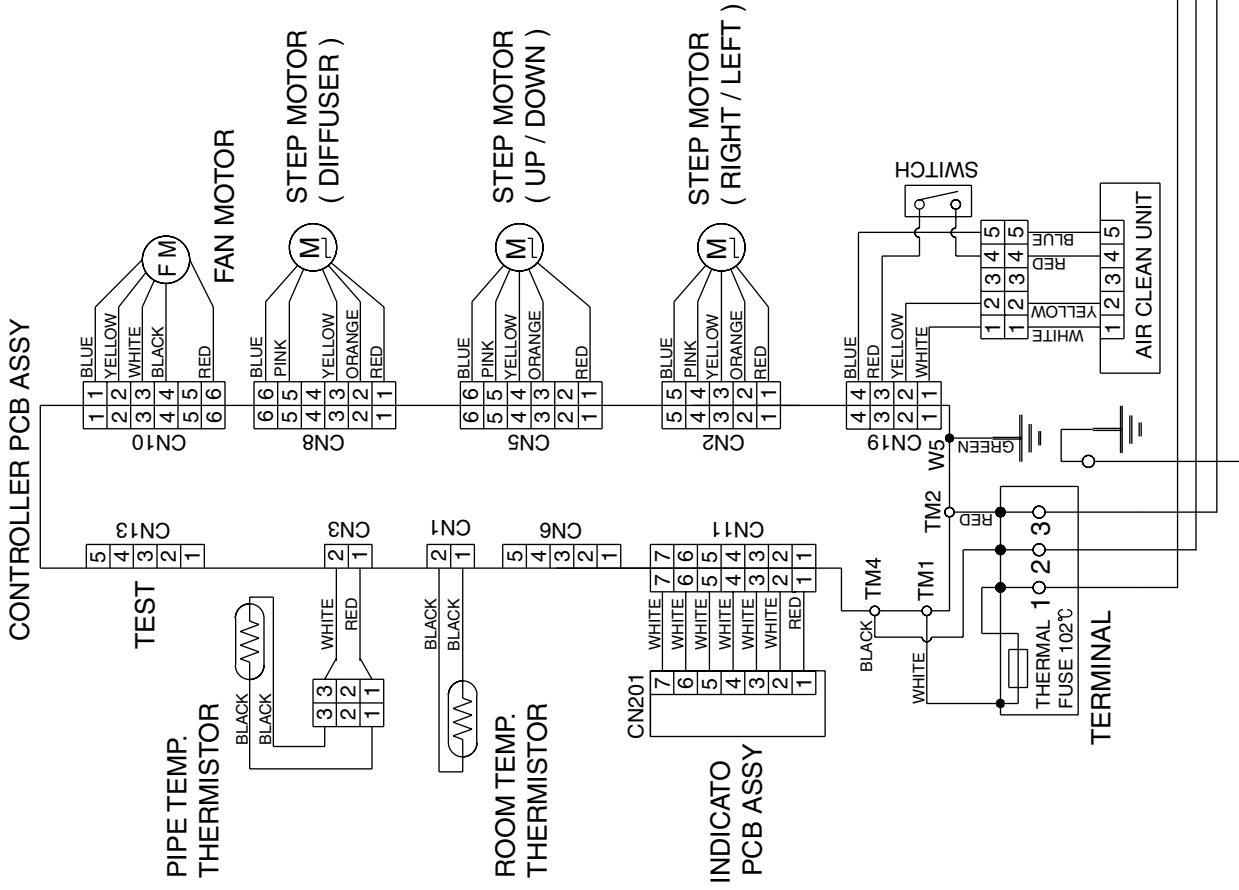

OUTDOOR UNIT

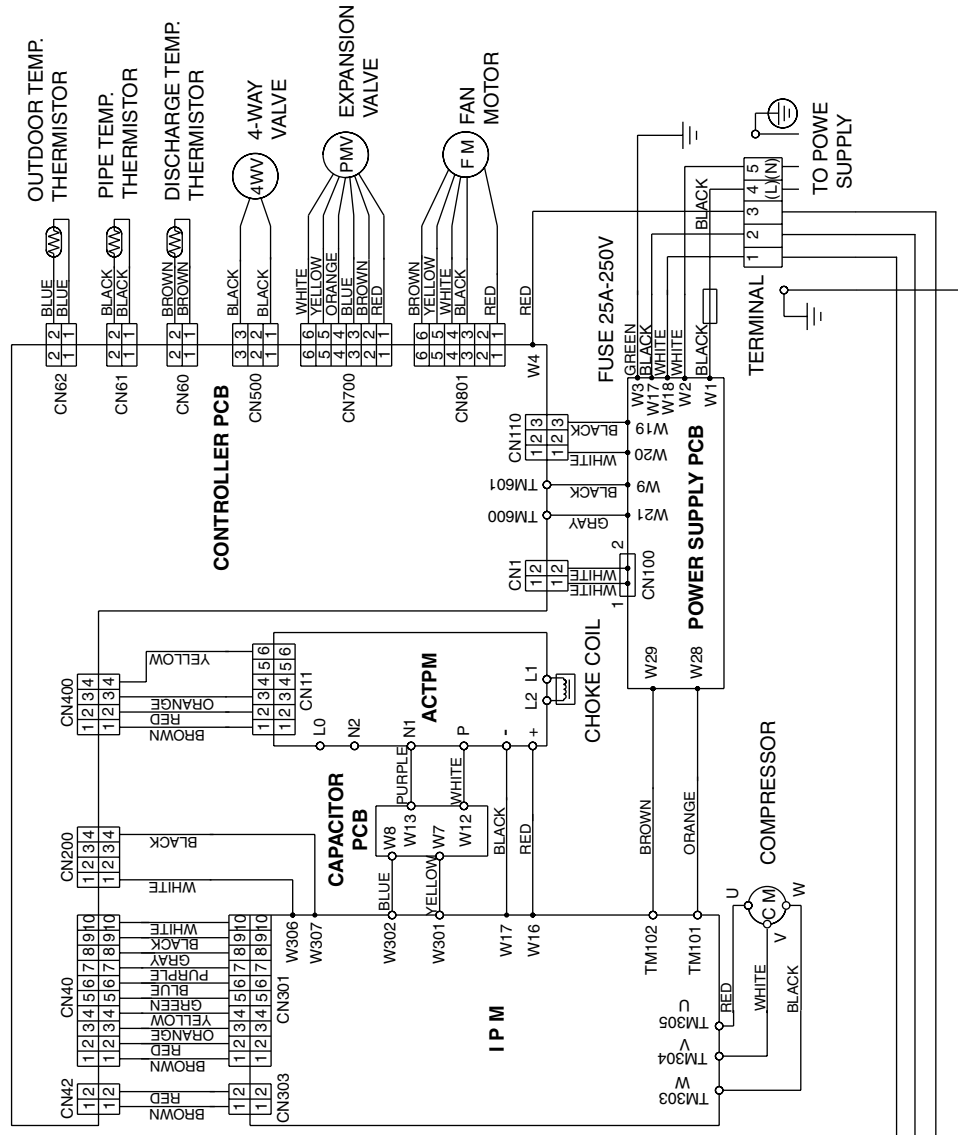

INDOOR PCB CIRCUIT DIAGRAM

CONTROL UNIT
EZ-006MHSE

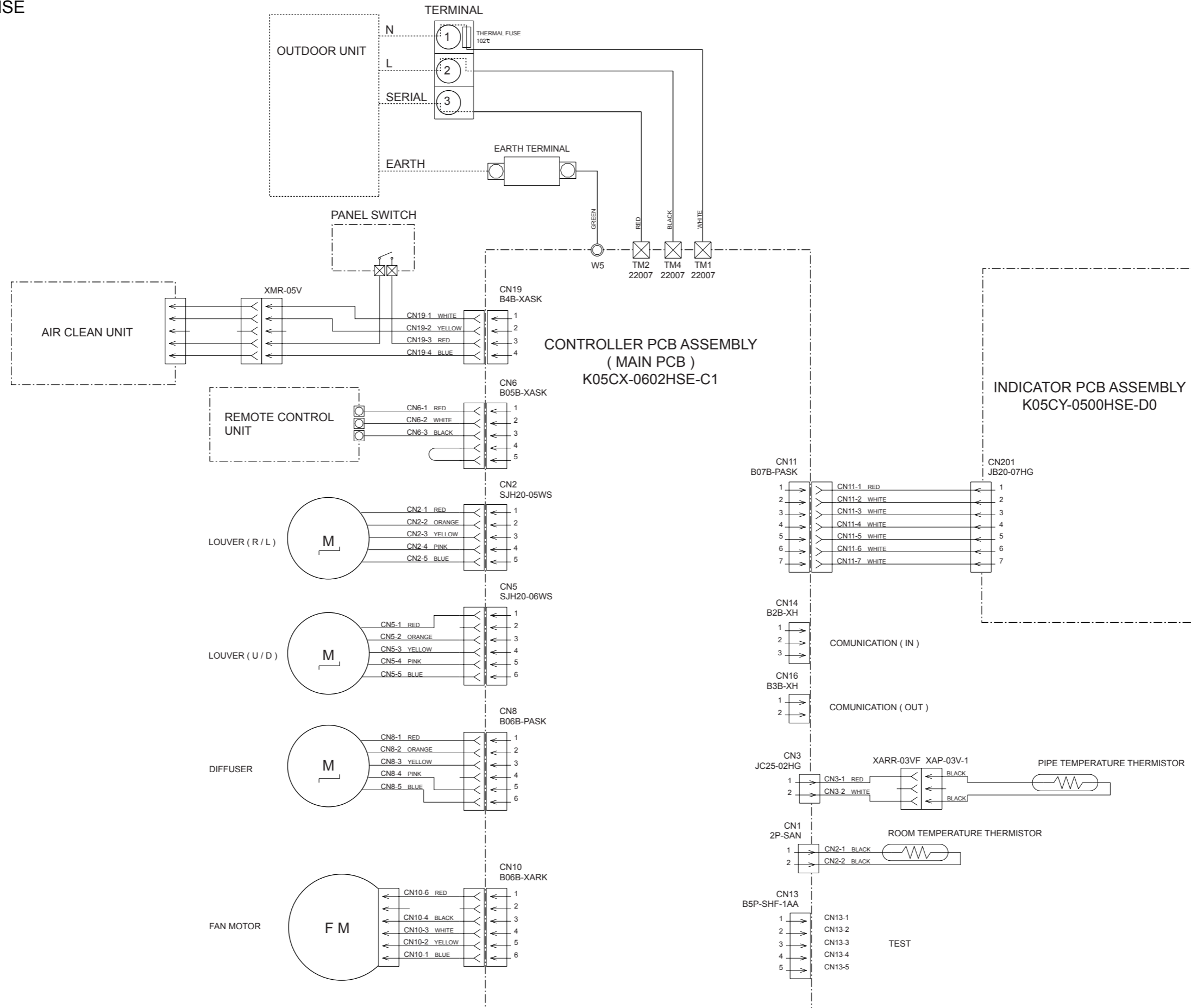

INDOOR UNIT
 CONTROLLER PCB ASSEMBLY (MAIN PCB)
 K05CX-0602HSE-C1

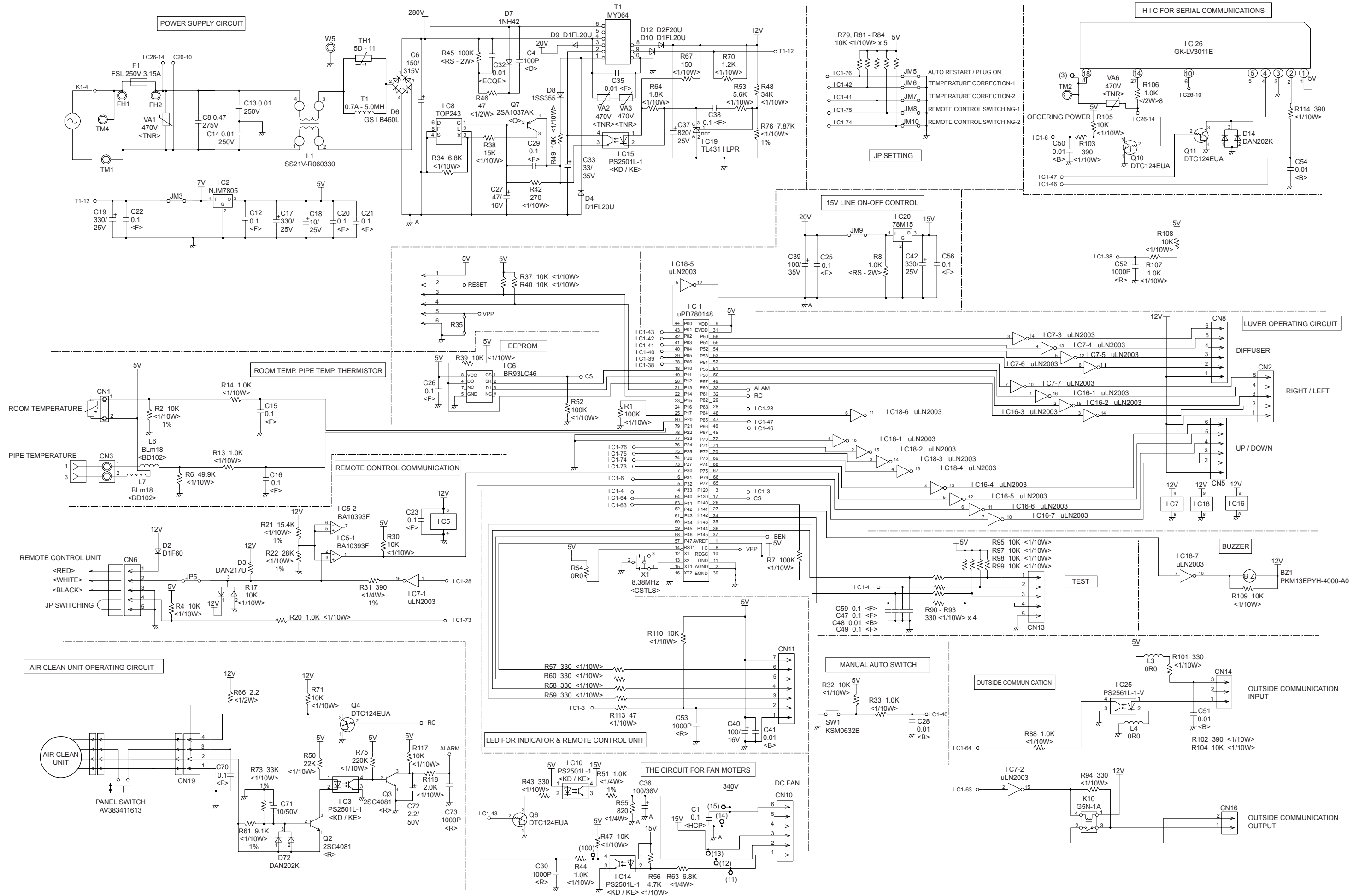

INDOOR UNIT

INDICATOR PCB ASSY
K05CY-0500HSE-D0

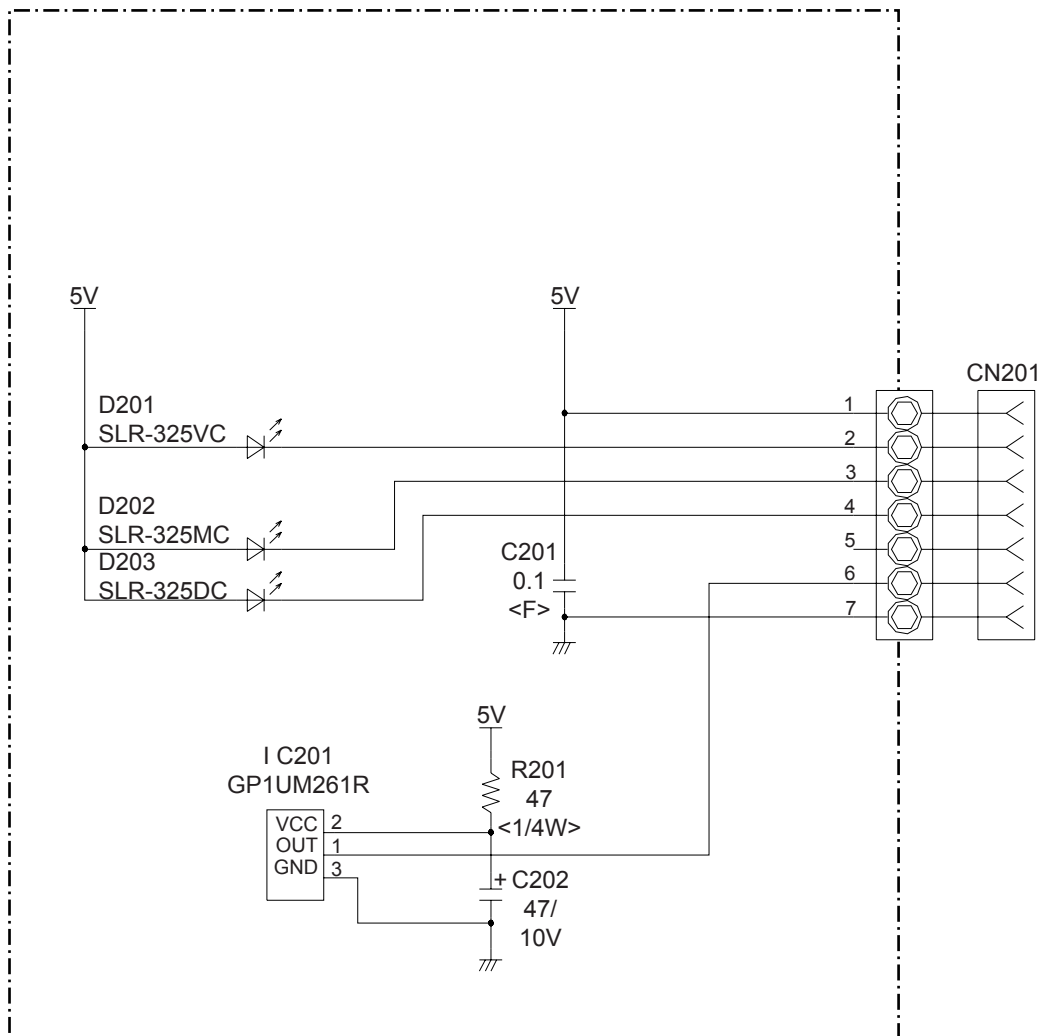

OUTDOOR PCB CIRCUIT DIAGRAM

INVERTER ASSEMBLY EZ-006THUE

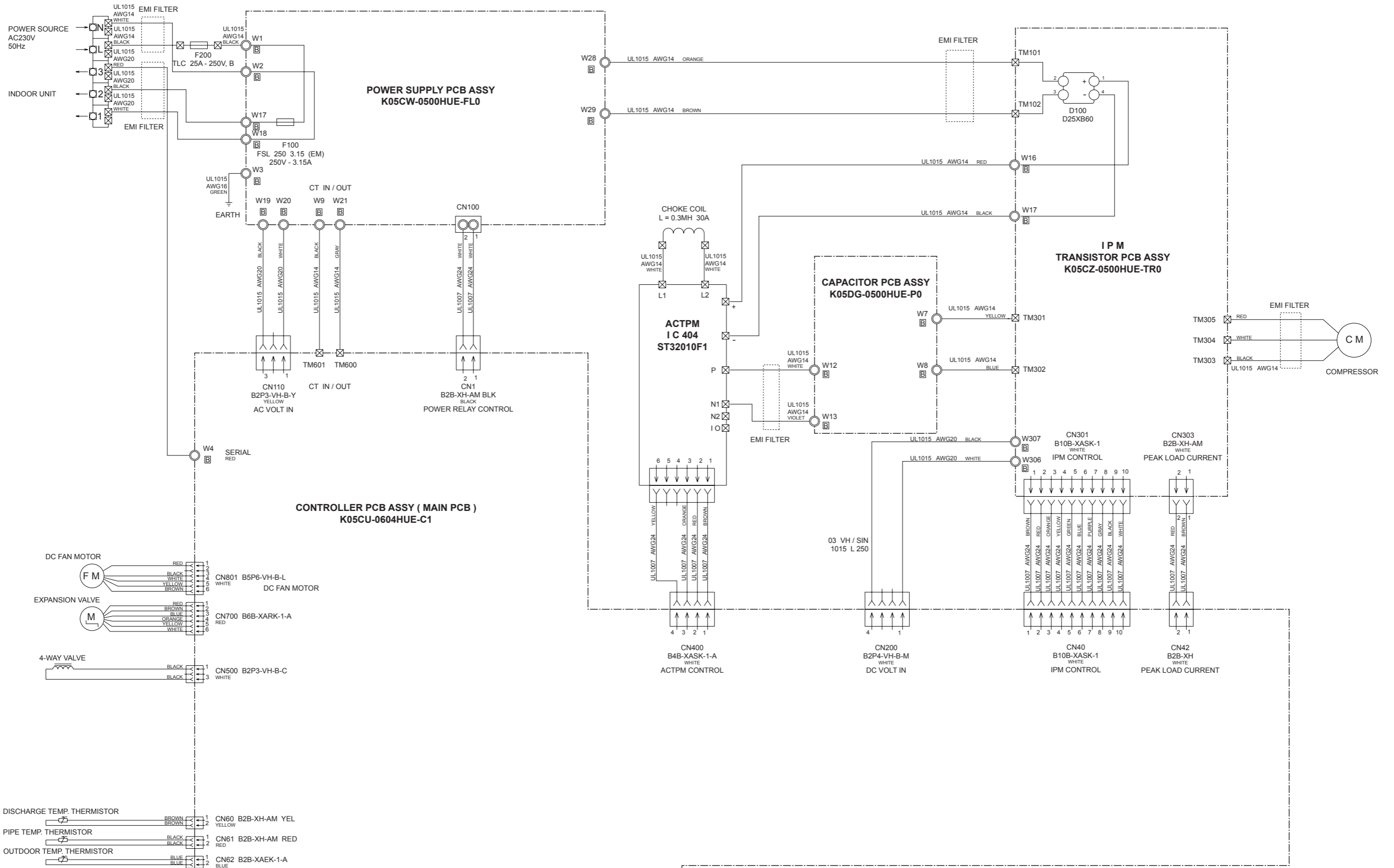

OUTDOOR UNIT
 CONTROLLER PCB ASSY
 K05CU-0604HUE-C1

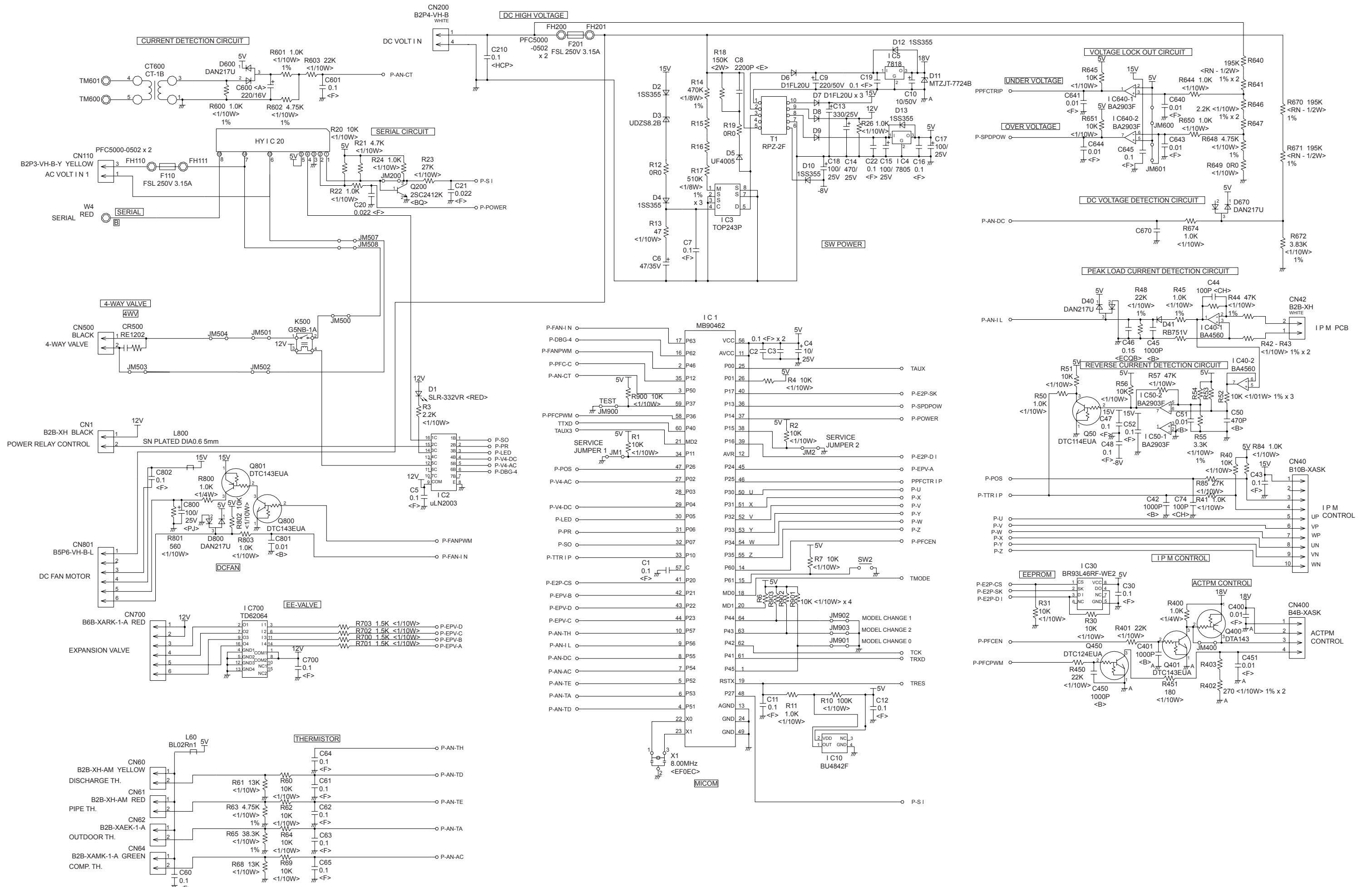

OUTDOOR UNIT

POWER SUPPLY PCB ASSEMBLY K05CW-0500HUE-FL0

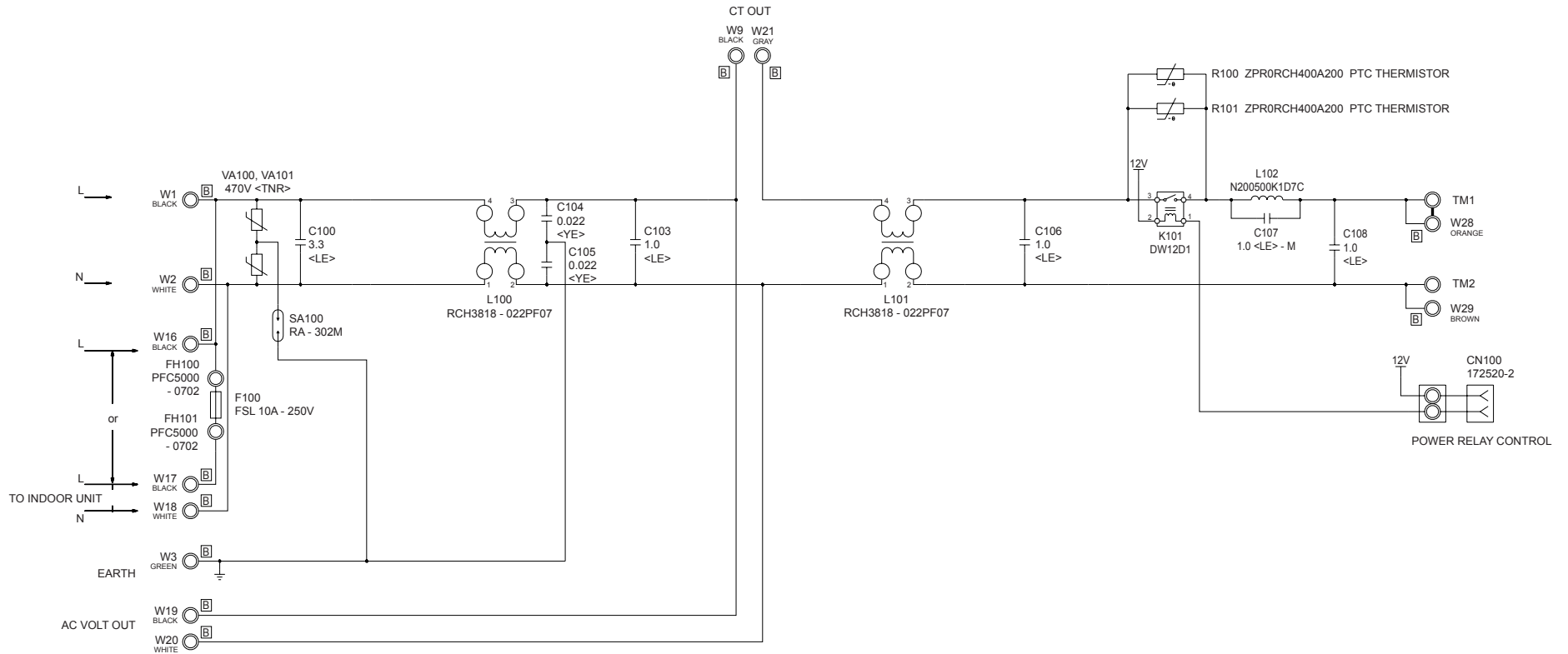

OUTDOOR UNIT

TRANSISTOR PCB ASSEMBLY
K05CZ-0500HUE-TR0

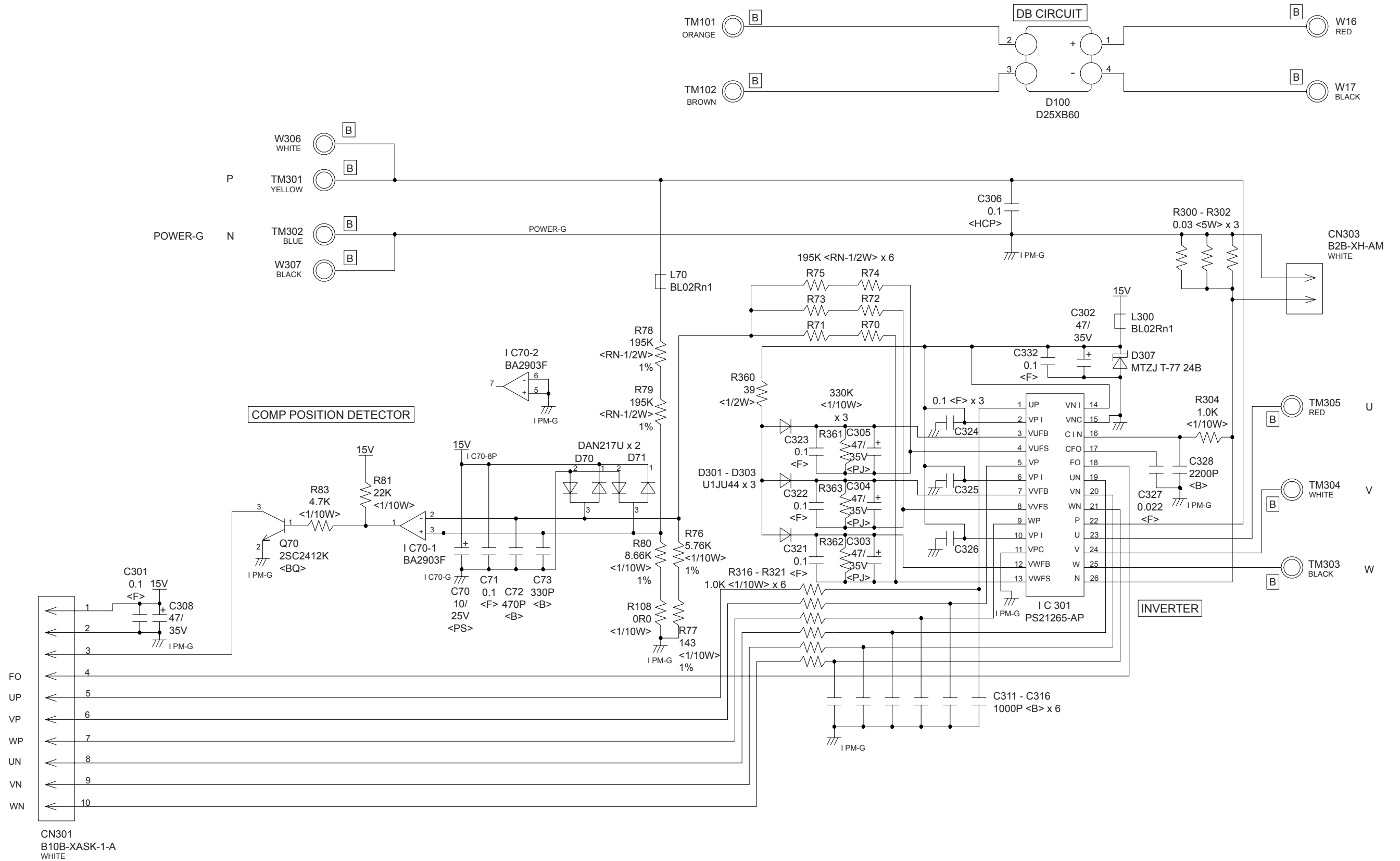

OUTDOOR UNIT

CAPACITOR PCB ASSY
K05DG-0500HUE-P0

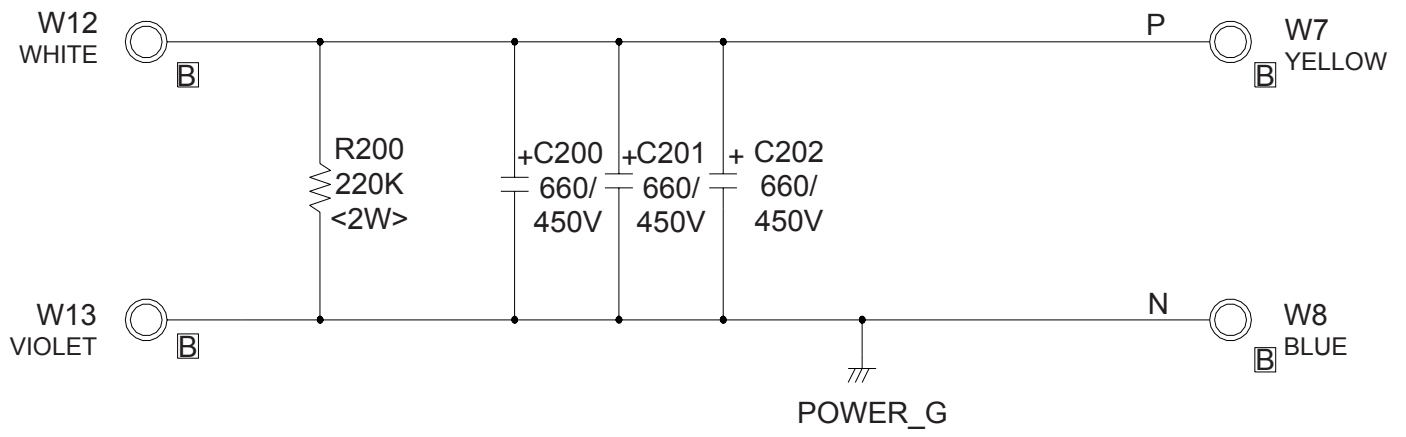

ERROR CONTENTS

Error	Display		Error
	Operation LED	Timer LED	
Serial signal error	Normal	2 flash	Serial signal (reverse) error, at operation start up
		3 flash	Serial signal (reverse) error, during operation
		4 flash	Serial signal (forward) error, at operation start up
		5 flash	Serial signal (forward) error, during operation
		8 flash	Wired remote controller error
Indoor unit thermistor error	2 flash	2 flash	Indoor temperature thermistor open / short
		3 flash	Heat exchanger middle thermistor open / short
Outdoor unit thermistor error	3 flash	2 flash	Discharge thermistor open / short
		3 flash	Heat exchanger thermistor open
		4 flash	Outdoor temperature thermistor open / short
		8 flash	Compressor temperature thermistor open / short
Indoor unit control error	4 flash	2 flash	Forced automatic SW welded
		3 flash	Main relay welded
		4 flash	Power interruption error
		7 flash	VDD permanent stop protection
		8 flash	reverse VDD permanent stop protection
Outdoor unit control error	5 flash	2 flash	Current trip error
		3 flash	CT abnormal
		5 flash	Compressor location detection error
		6 flash	Outdoor unit fan drive system abnormal
Indoor fan motor error	6 flash	2 flash	Abnormal lock
		3 flash	Abnormal rotation
Refrigerant cycle error	7 flash	2 flash	Discharge Temperature abnormal
		3 flash	Cooling high pressure abnormal rise
		5 flash	Pressure switch trouble
Optional function error	8 flash	2 flash	Active filter voltage trouble (second time)
		3 flash	Active filter voltage trouble (first time)
		4 flash	PFC circuit error
Model information error	0.1 sec on/off	0.1 sec on/off	Model information error

DISASSEMBLY ILLUSTRATION

INDOOR UNIT

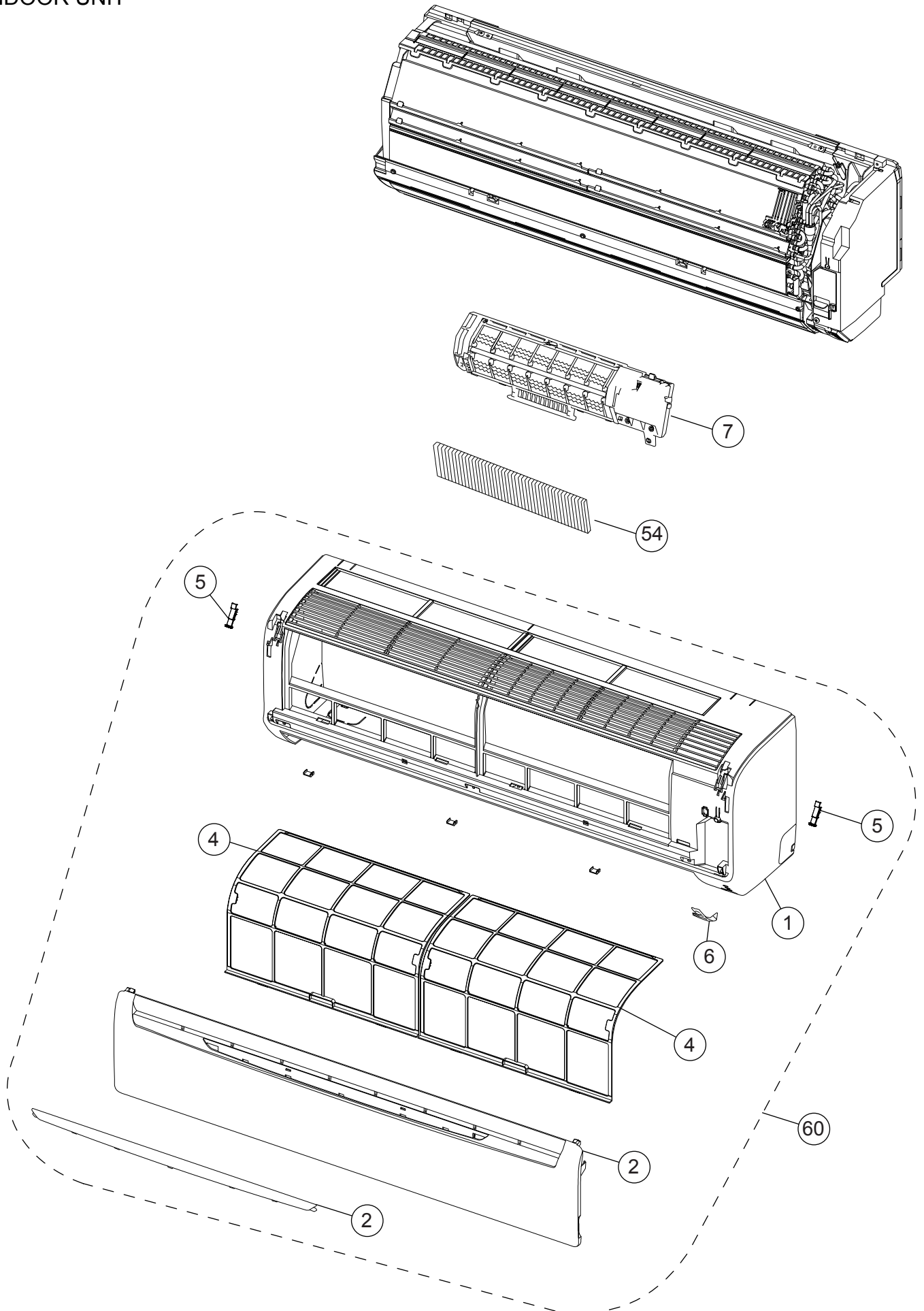

INDOOR UNIT

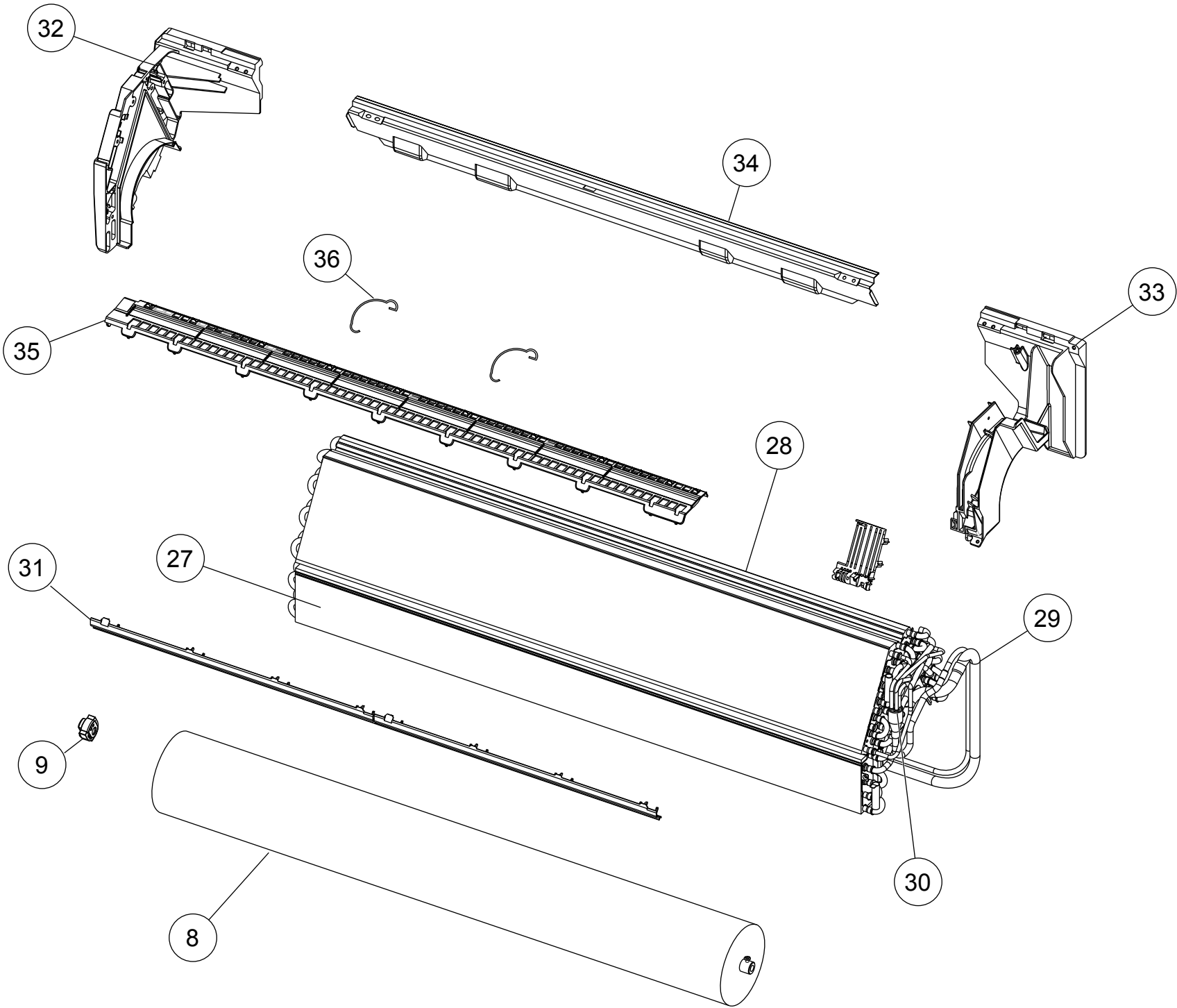

10

26

23

22

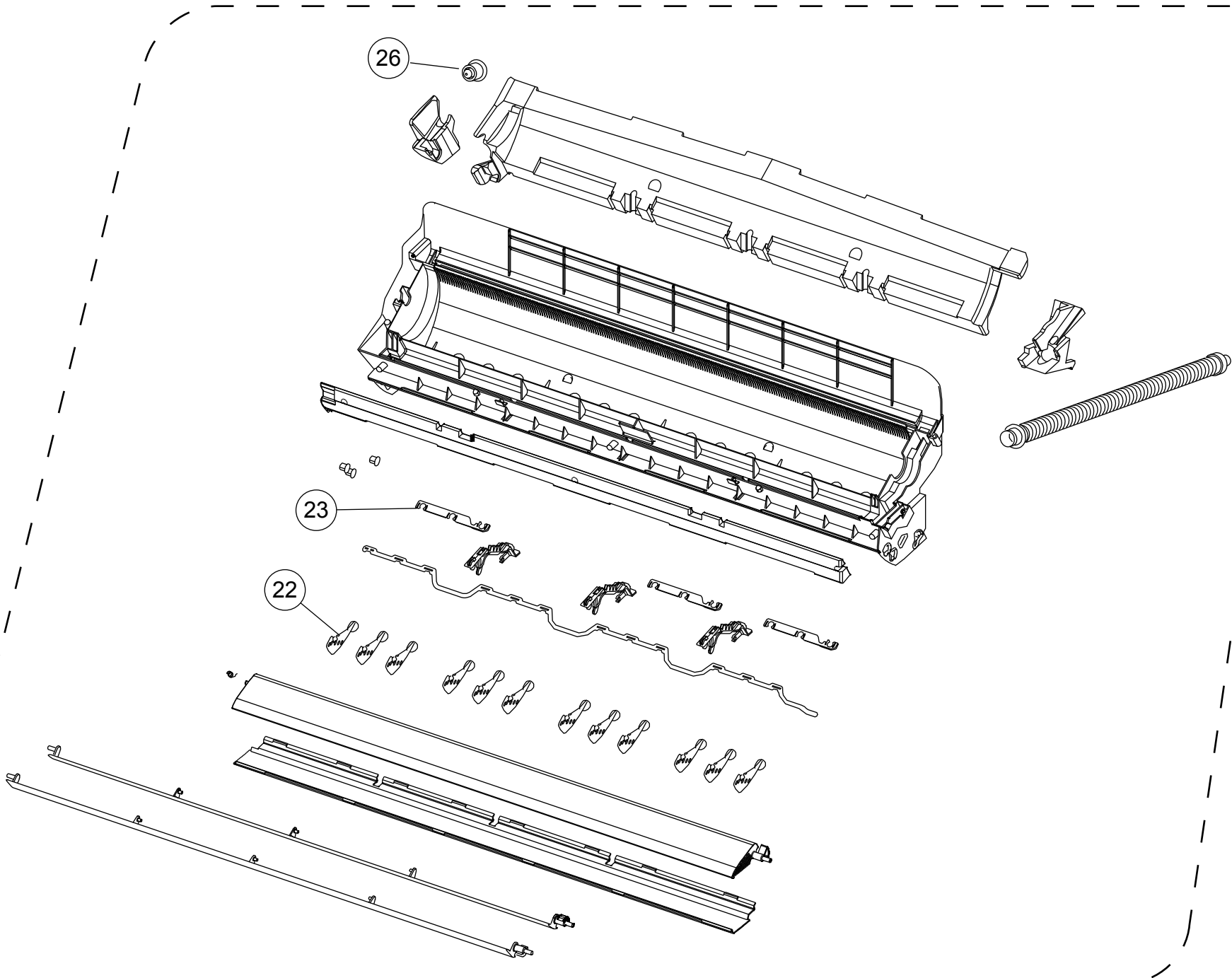

INDOOR UNIT

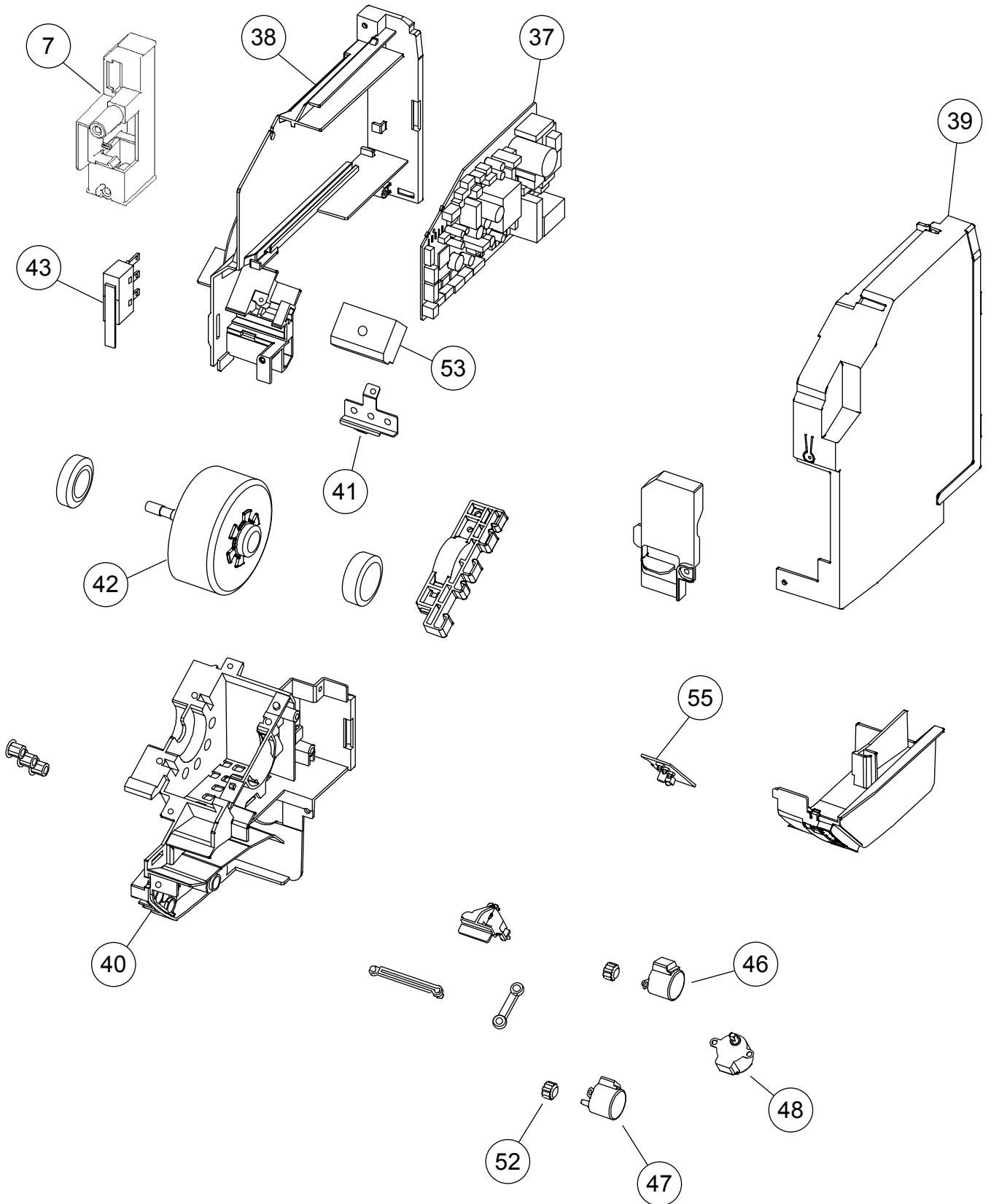

OUTDOOR UNIT

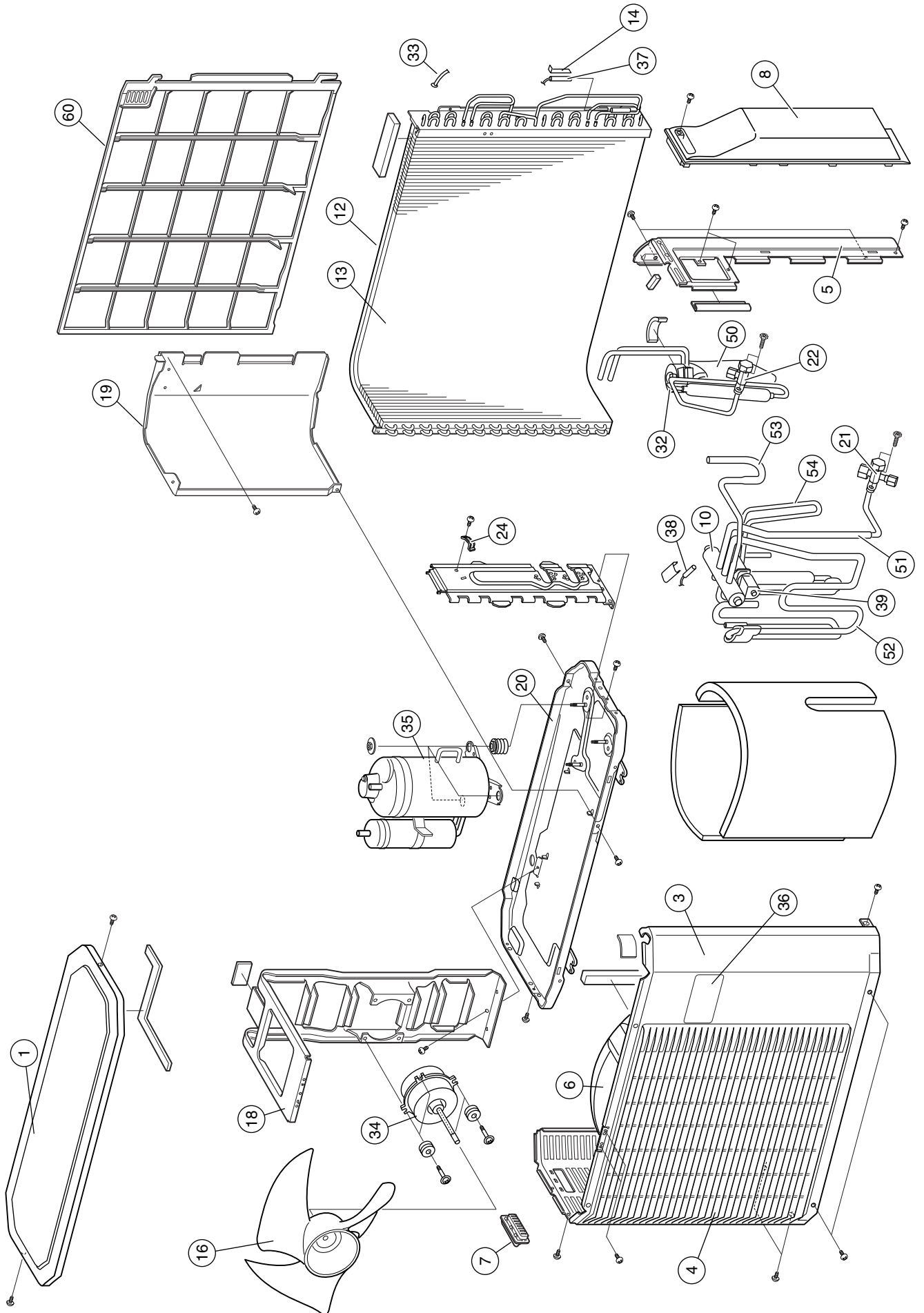

OUTDOOR UNIT

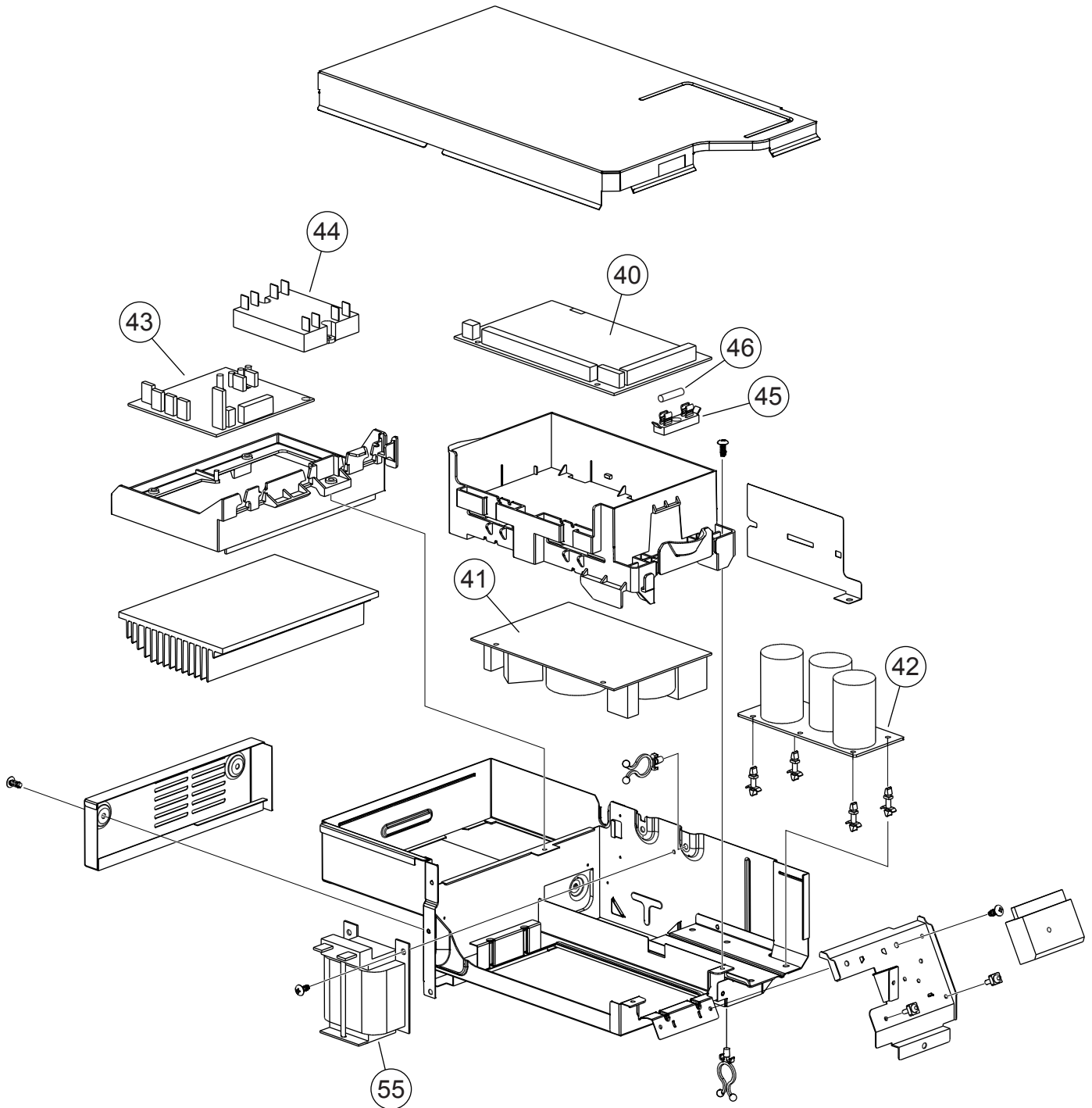

PARTS LIST







INDOOR UNIT

Ref No	Description	Part No	Ord. Q'ty
		ASHB24LDC	
1	Front Panel	9314991042	
2	Intake Grille Assy	9315336095	
4	Air Filter	9315014016	
5	Clamper Grille	9306755010	
6	Receiver Window	9315010018	
7	Air Cleaner Assy	9313148041	
8	Crossflow Fan Assy	9315024015	
9	Bearing C Assy	9306628017	
10	Casing Assy	9315331014	
22	R and L Louver	9311997016	
23	Spacer B	9312441013	
26	Drain Cap	9367677009	
27	Evaporator Assy	9315347015	
28	Evaporator Assy B	9315349019	
29	Connection Pipe Assy	9315354013	
30	Distributor Assy	9315350015	
31	Water Seal	9315251015	
32	Evaporater Holder R	9314994012	
33	Evaporater Holder L	9314995019	
34	Rear Bracket	9315022011	
35	Filter Guide	9315013019	
36	Filter Guard	9315411013	
37	Controller PCB Assy	9707090154	
38	Control Box	9314996016	
39	Control Cover	9314997013	
40	Motor Case	9314998010	
41	Terminal Earth	9315028013	
42	DC Brushless Motor	9602163014	
43	SWITCH MICRO	9900286026	
46	Motor, Step	9900384029	
47	Motor, Step	9900384036	
48	Motor, Step	9900139063	
52	Gear A	9309994003	
53	Terminal	9900385019	
54	Air Clean Filter	9313275013	
55	Indicator PCB Assy	9707210019	
60	Front Panel Total Assy	9315335128	
---	Remote Controller	9315027122	

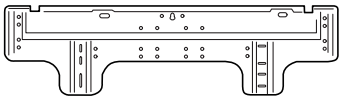
OUTDOOR UNIT

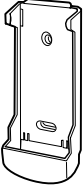
Ref No.	Description	Parts No.	Ord. Q'ty
		AOHS24LDC	
1	Top Panel Assy	9309230064	
3	Cabinet Sub Assy	9314809019	
4	Blow Grill	9308884015	
5	Cabinet Right Assy	9309236028	
6	Fan Ring	9308885012	
7	Grip	9308880017	
8	Switch Cover Assy	9309237032	
10	4-Way Valve	9900163013	
12	Condenser Assy B	9315303011	
13	Condenser Assy	9315302014	
14	Thermistor Spring A	313728262708	
16	Propeller Fan	9309909014	
18	Motor Bracket Assy	9313432027	
19	Separator	9315213013	
20	Base Assy	9315296023	
21	3-Way Valve Assy	9315414014	
22	2-Way Valve Assy	9313062019	
24	Cord Clamp	9307271014	
32	Expansion Valve Coil	9900057039	
33	Outdoor Temp. Thermistor	9703516108	
34	DC Brushless Motor	9602110018	
35	Compressor Assy	9315297013	
36	Emblem Rear	9315211019	
37	Heat Exchanger Thermistor	9704220059	
38	Discharge Thermistor	9704219091	
39	Solenoid	9970055010	
40	Inverter PCB Assy	9707121209	
41	Capacitor PCB Assy	9707128055	
42	Power PCB Assy	9707129052	
43	TR PCB Assy	9707125054	
44	ACTPM	9703457012	
46	Fuse	0600086039	
45	Fuse Holder	0500158072	
50	Pulse Motor Valve Assy	9315310019	
51	Joint Pipe (3 Way Valve) Assy	9315308016	
52	Pipe (Condenser Outlet) Assy	9315304018	
53	Pipe (Condenser Inlet) Assy	9315305015	
54	Discharge Pipe Assy	9315312013	
55	Chock Coil	9900366018	
60	Protective Net	9315033017	

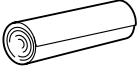
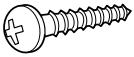
STANDARD ACCESSORIES

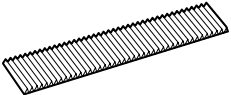
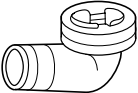
Name and Shape	Part No.
Wall hook bracket 	9315023018
Remote control unit 	9315027122
Remote control unit holder 	9305642045
Battery (penlight) 	0600185534
Cloth tape 	9310519004
Tapping screw (big) 	0700076046
Tapping screw (small) 	0700019036
Air cleaning filter 	9313275013
Drain pipe 	9301102000

0610G3164