



**INVERTER MULTI  
AIR CONDITIONER**

**WALL MOUNTED** type

# SERVICE MANUAL



## Models

Indoor unit		Outdoor unit
ASHA14LACM	—	AOHA18LAT3
ASHA14LACM	}	AOHA24LAT3
ASHA18LACM		

## CONTENTS

SPECIFICATIONS .....	1
OUTLINE AND DIMENSIONS .....	3
REFRIGERANT SYSTEM DIAGRAM .....	5
CIRCUIT DIAGRAM .....	6
INDOOR PCB CIRCUIT DIAGRAM .....	8
OUTDOOR PCB CIRCUIT DIAGRAM .....	11
ERROR CONTENTS .....	14
DISASSEMBLY ILLUSTRATION .....	16
PARTS LIST .....	21
STANDARD ACCESSORIES .....	23

## SPECIFICATIONS

### INDOOR UNIT

TYPE	COOL & HEAT	
INDOOR UNIT	ASHA14LACM	ASHA18LACM

### ELECTRICAL DATA

COOLING CAPACITY	4.2 kW	5.0 kW
HEATING CAPACITY	4.8 kW	6.0 kW
MOISTURE REMOVAL	2.1 L/hr	2.8 L/hr
AIR CIRCULATION HIGH	700 m <sup>3</sup> /hr	700 m <sup>3</sup> /hr

### FAN MOTOR

POWER SOURCE		230 V	
FAN SPEED ( cool / heat )	Discrimination	MFD-34ROM	
	High	1,480 / 1,480 r.p.m.	1,480 / 1,480 r.p.m.
	Med	1,250 / 1,250 r.p.m.	1,250 / 1,250 r.p.m.
	Low	1,050 / 1,100 r.p.m.	1,100 / 1,100 r.p.m.
	Quiet	850 / 950 r.p.m.	950 / 950 r.p.m.

DIMENSIONS	H x W x D	275 x 790 x 215 mm
WEIGHT	Gross / Net	12 / 9 kg

NOISE LEVEL	High	45 dB	45 dB
	Quiet	26 dB	28 dB

## OUTDOOR UNIT

TYPE	Colling & Heating	
MODEL NAME	AOHA18LAT3	AOHA24LAT3
COOLING CAPACITY	5.4 kW	6.8 kW
HEATING CAPACITY	6.8 kW	8.0 kW

## ELECTRICAL SPECIFICATIONS

POWER SUPPLY	(220V) - 230V - (240V)		
FREQUENCY	50 Hz		
RUNNING CURRENT	Cooling	5.9 A	8.5 A
	Heating	7.1 A	8.8 A
INPUT	Cooling	1.35 kW	1.94 kW
	Heating	1.62 kW	2.00 kW
EER	Cooling	4.00 kW/kW	3.50 kW/kW
	Heating	4.20 kW/kW	4.00 kW/kW
AIR CIRCULATION HIGH	3,050 m <sup>3</sup> /hr	3,300 m <sup>3</sup> /hr	

## COMPRESSOR

TYPE	Hermetic type, Inverter, 4 poles, 3-phase, DC motor, Twin Rotary	
DISCRIMINATION	DA150A1F-20NA	
REFRIGERANT	R410	2,200 g

## FAN MOTOR

DISCRIMINATION	MFE-60PO	
HIGH SPEED (COOL)	730 r.p.m.	780 r.p.m.
HIGH SPEED (HEAT)	660 r.p.m.	780 r.p.m.

DIMENSIONS	H x W x D	700 x 900 x 330 mm
WEIGHT	Net / Gross	55 kg / 63 kg

## REFRIGERANT CHARGE (R410A)

FULL CHARGE AMOUNT	Total Pipe Length	30.0 m	2,200 g
		40.0 m	2,400 g
		50.0 m	2,600 g
ADDITIONAL CHARGE			20 g / m
CHARGELESS			30 m
MAX PIPE LENGTH (each unit)			25 m
MAX PIPE LENGTH (total)			50 m
MAX ELEVATION (between indoor units)			10 m
MAX ELEVATION (between indoor and outdoor)			15 m
MIN. PIPE LENGTH (each unit)			5 m

## DIMENSIONS

### INDOOR UNIT

(unit : mm)

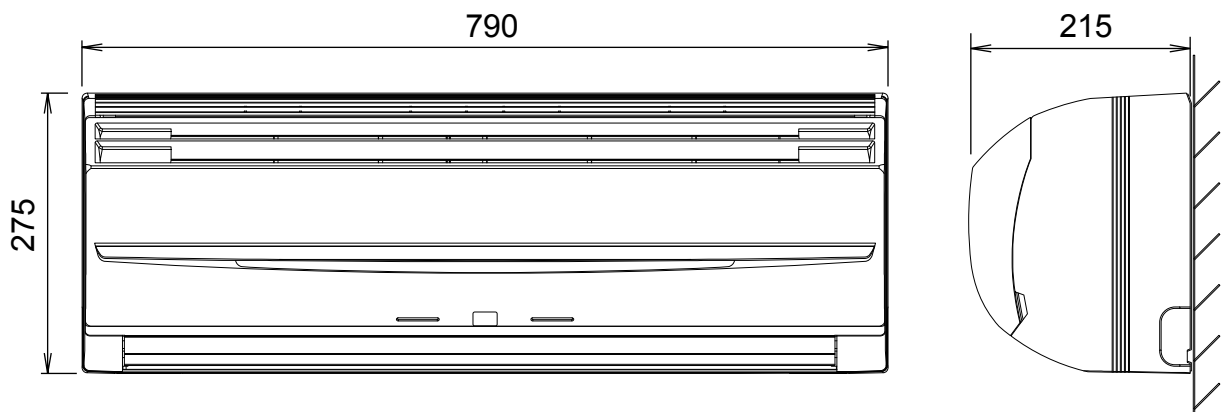

# OUTDOOR UNIT

(Unit : mm)

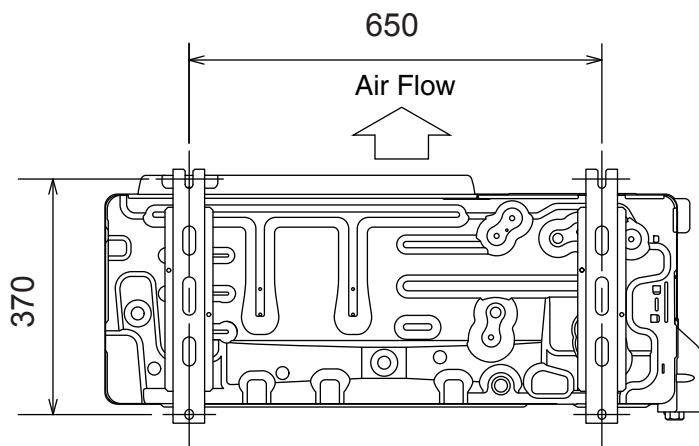
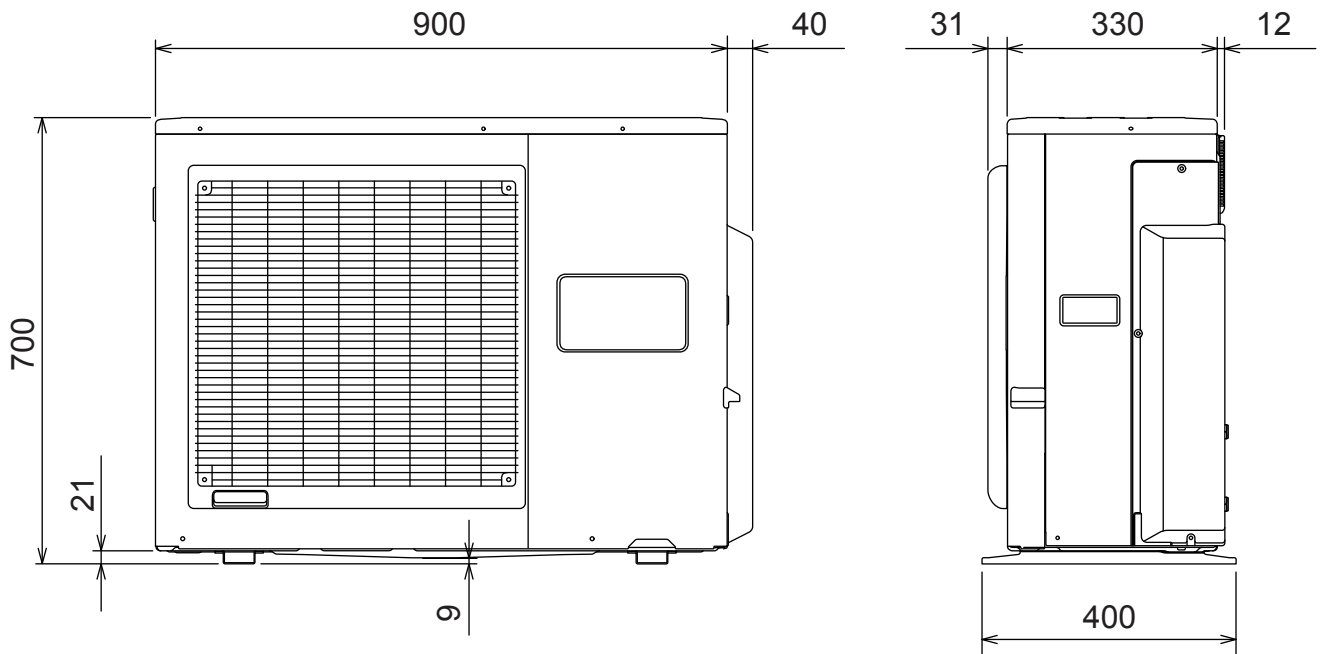
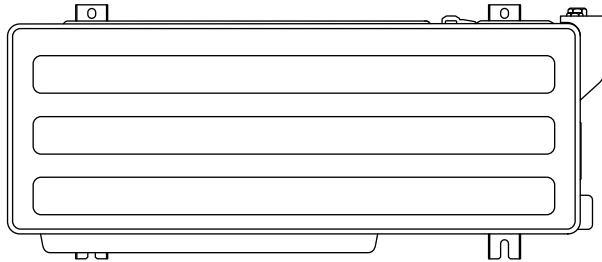

# REFRIGERANT SYSTEM DIAGRAM

## OUTDOOR UNIT

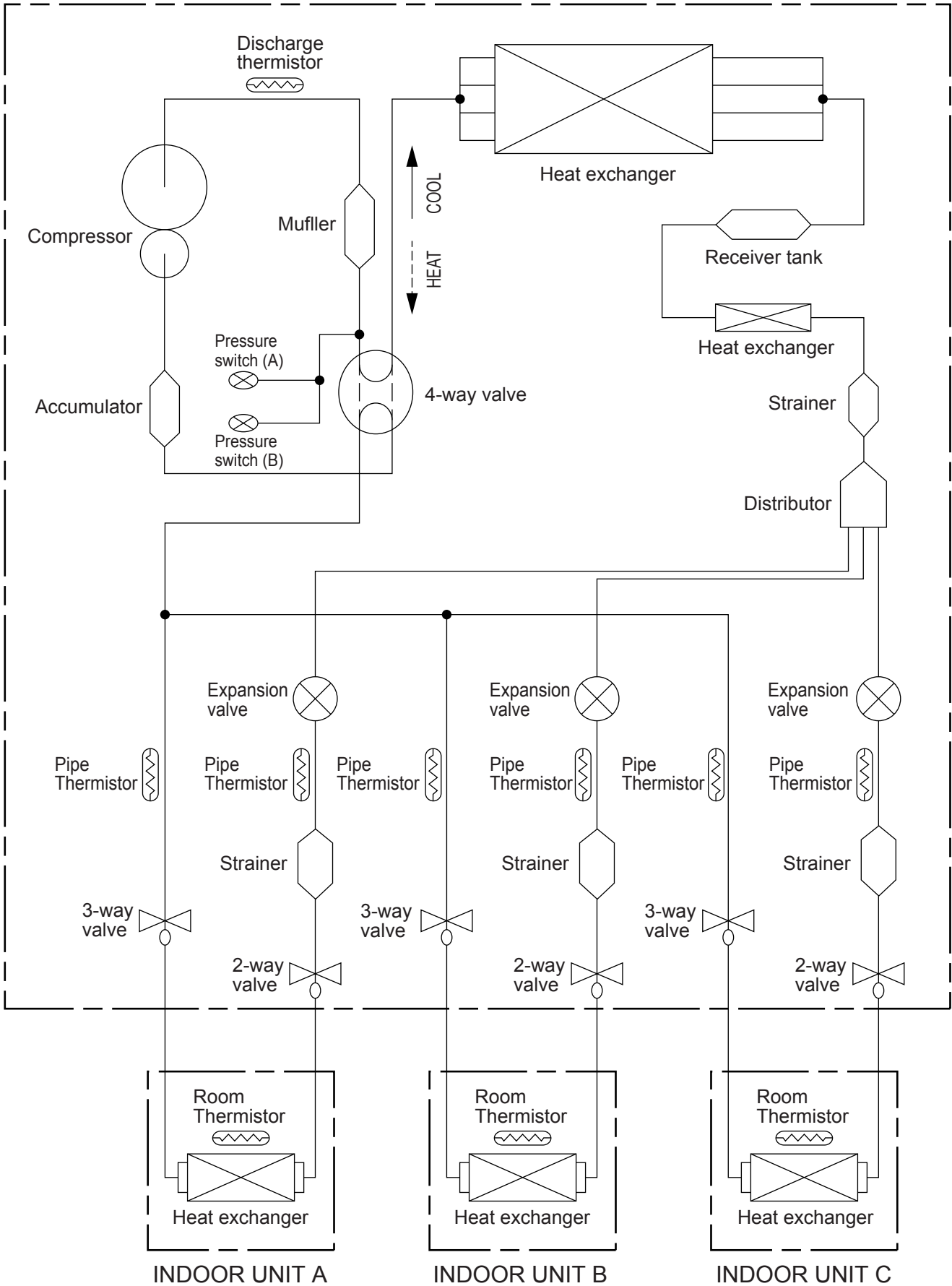

# CIRCUIT DIAGRAM

## INDOOR UNIT

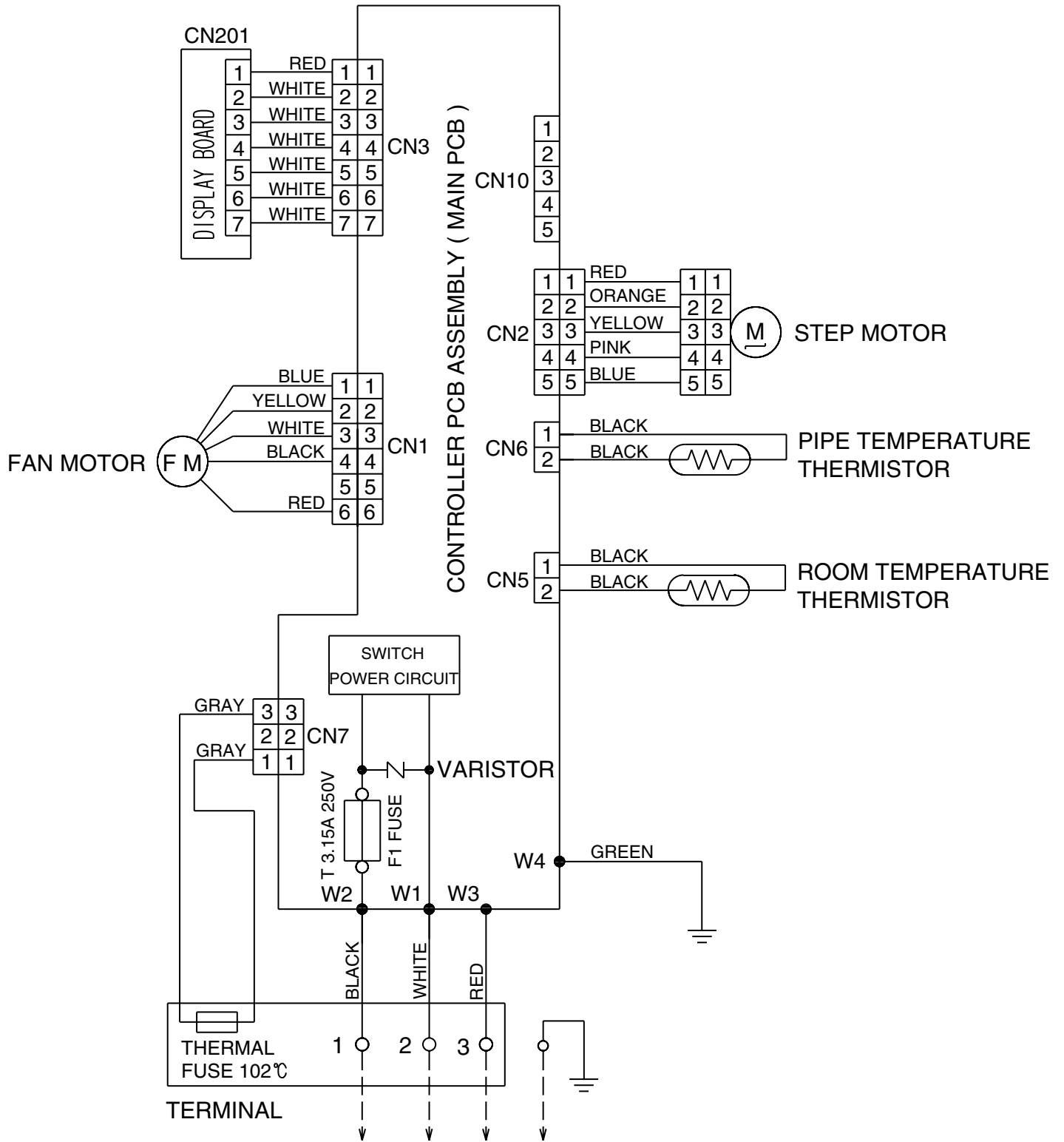

# OUTDOOR UNIT

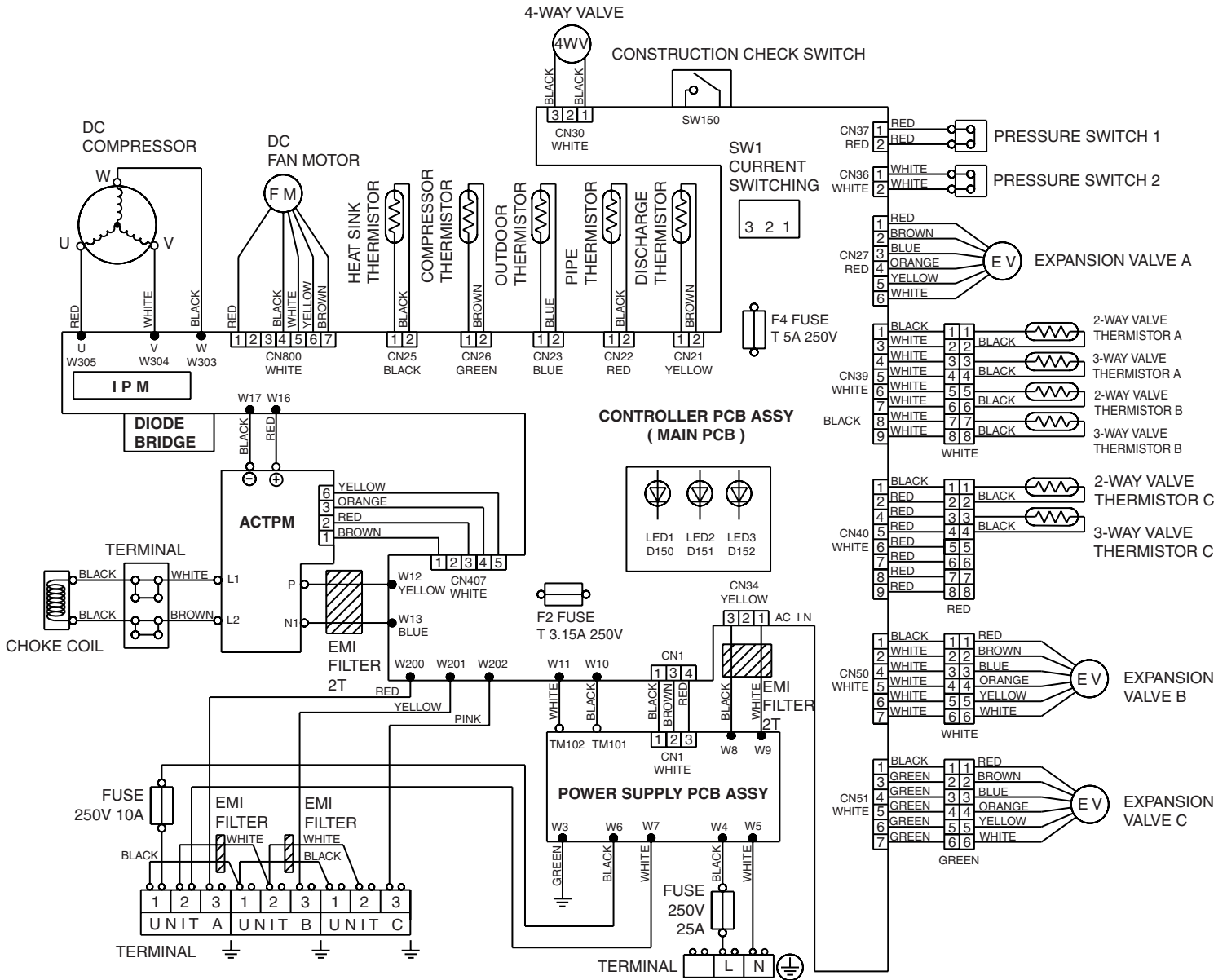



# INDOOR PCB CIRCUIT DIAGRAM

CONTROL UNIT  
 ASHA14LACM : EZ-006WHSE  
 ASHA18LACM : EZ-006YHSE

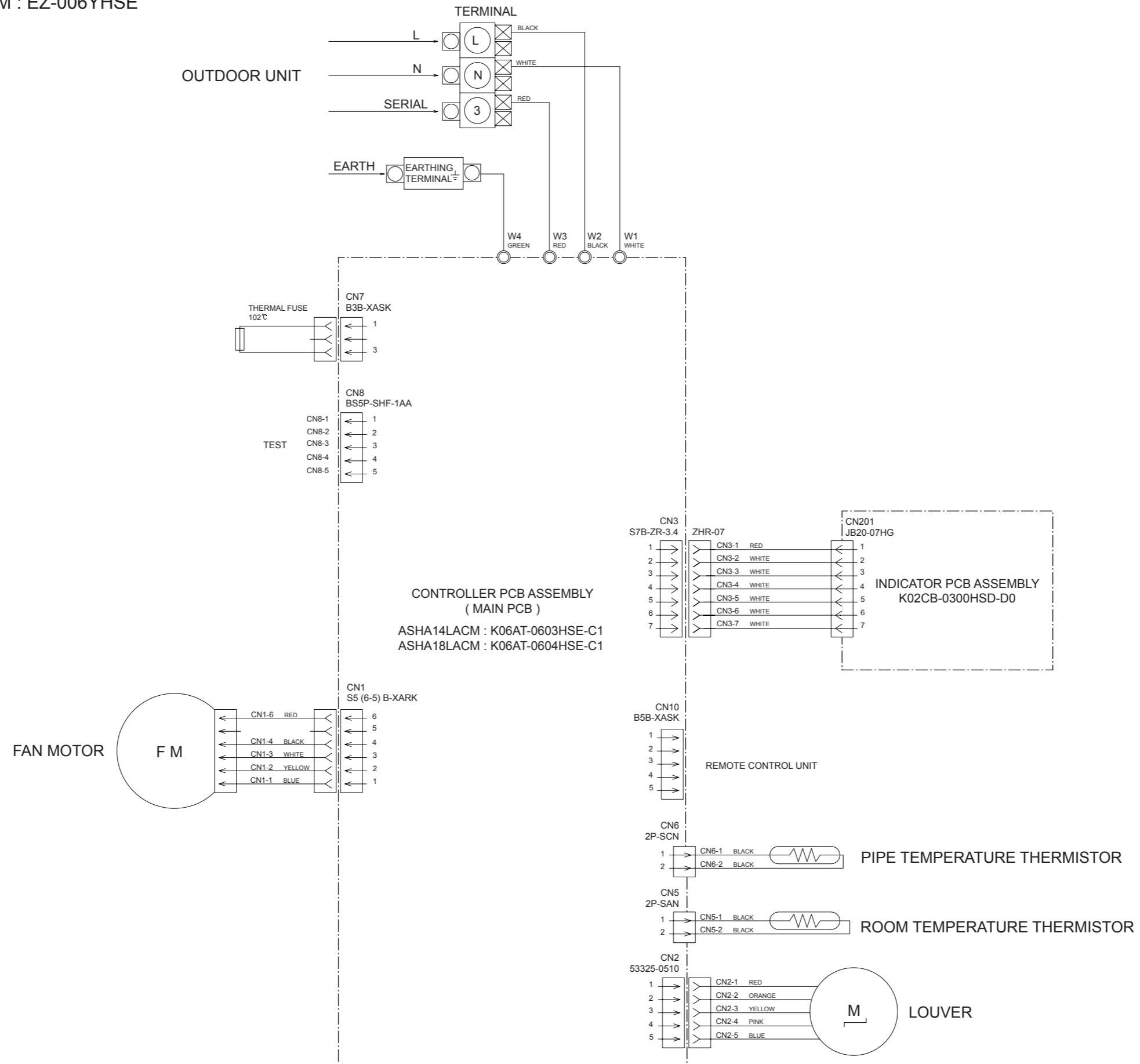

CONTROLLER PCB ASSEMBLY  
 ASHA14LATM : K06AT-0603HSE-C1  
 ASHA18LATM : K06AT-0604HSE-C1

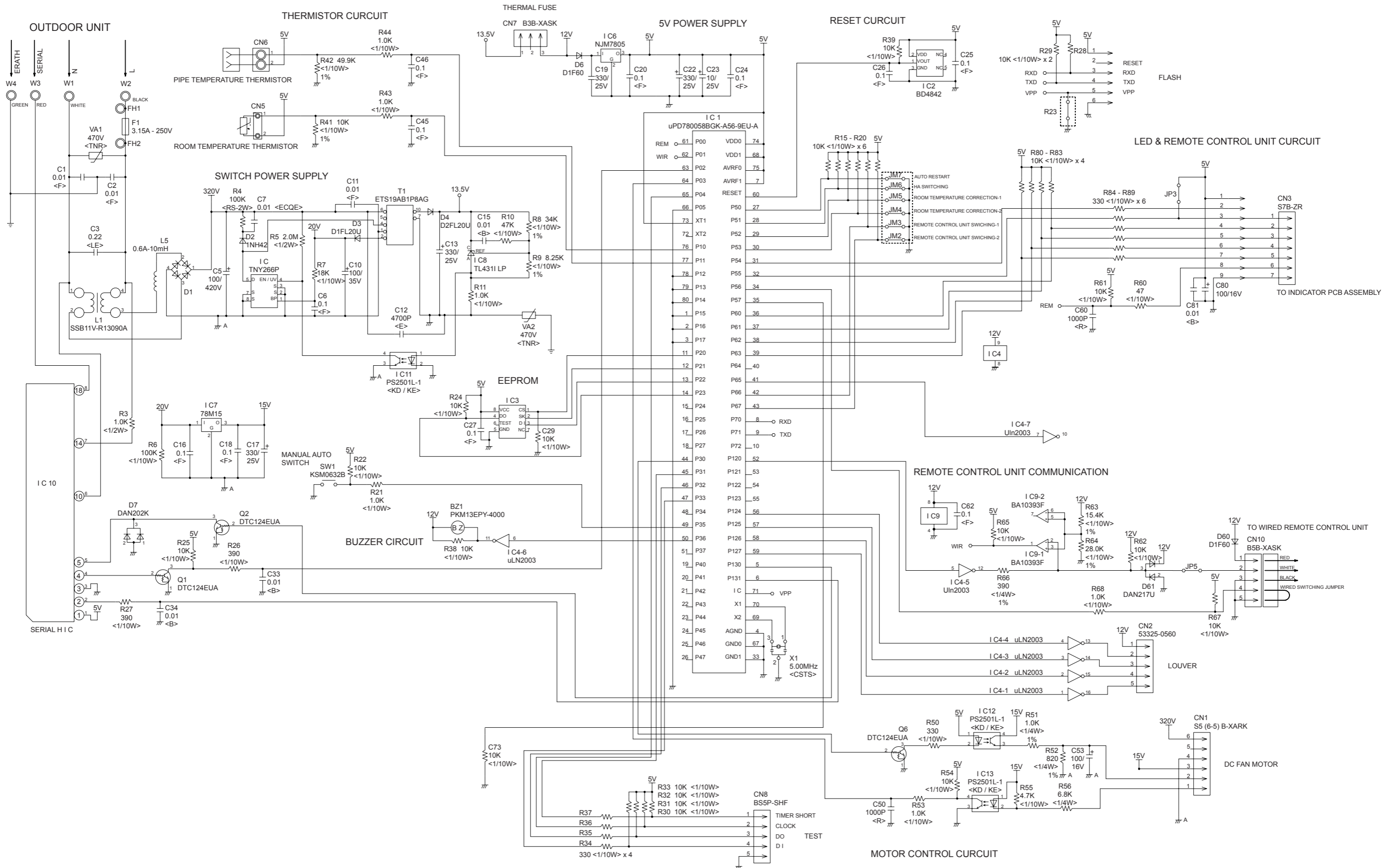

# INDOOR UNIT

## INDICATOR PCB ASSY K02CB-0300HSD-D0

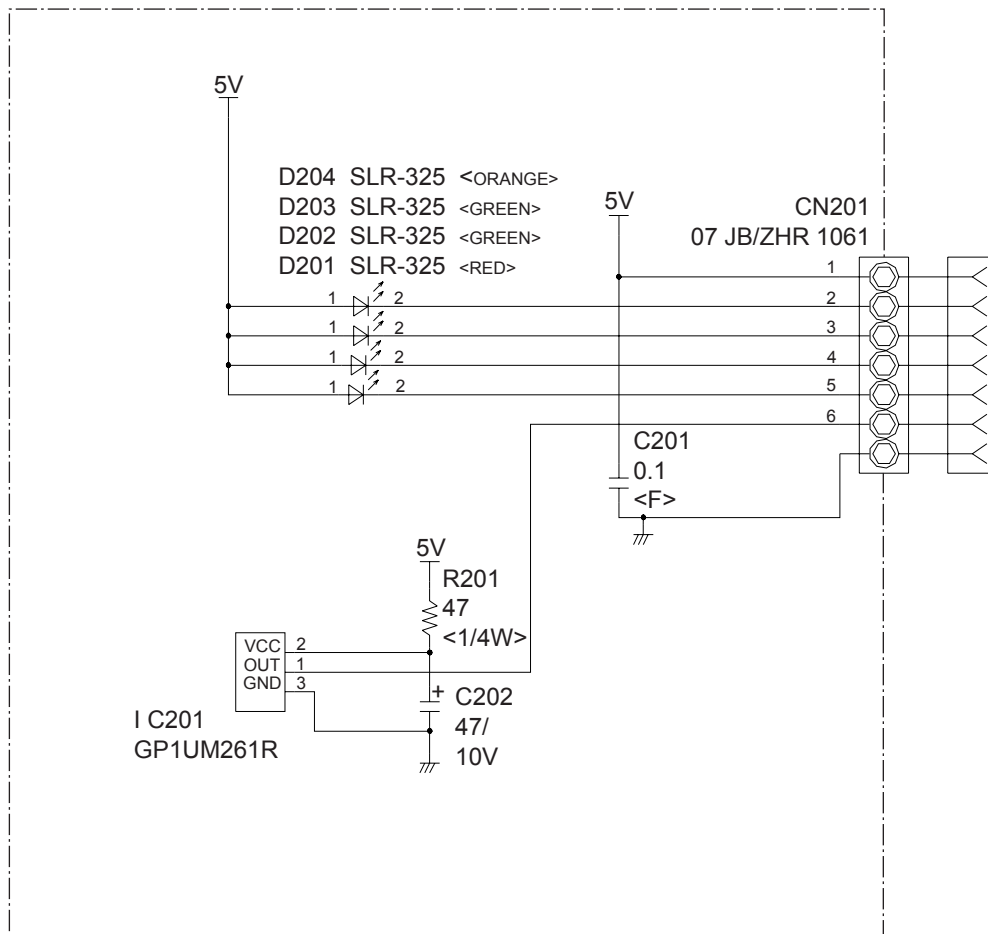

# OUTDOOR PCB CIRCUIT DIAGRAM

## INVERTER ASSEMBLY

AOHA18LAT3 : EZ-006KHUE

AOHA24LAT3 : EZ-0068HUE

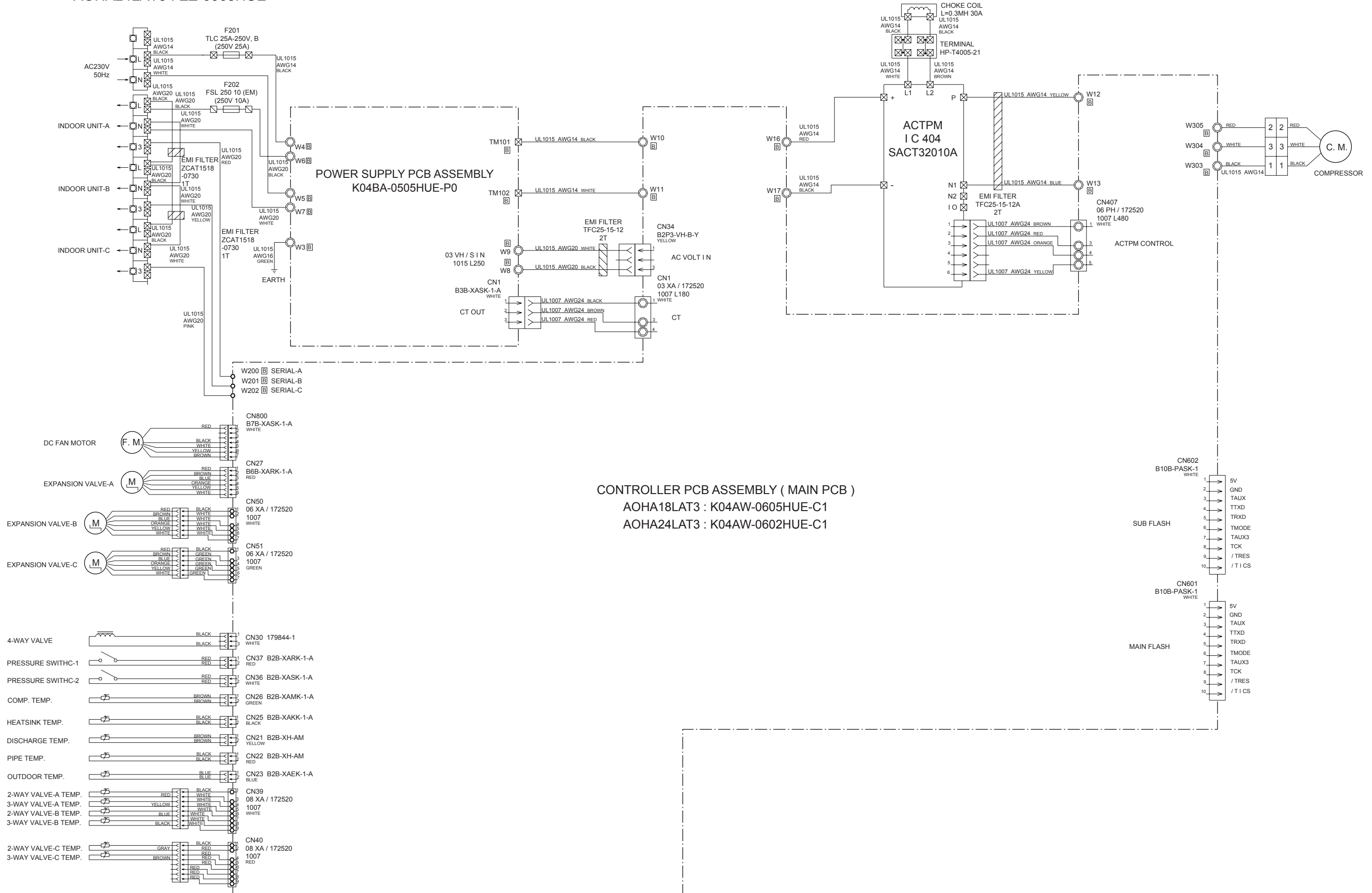

CONTROLLER PCB ASSEMBLY  
 AOHA18LAT3 : K04AW-0605HUE-C1  
 AOHA24LAT3 : K04AW-0602HUE-C1

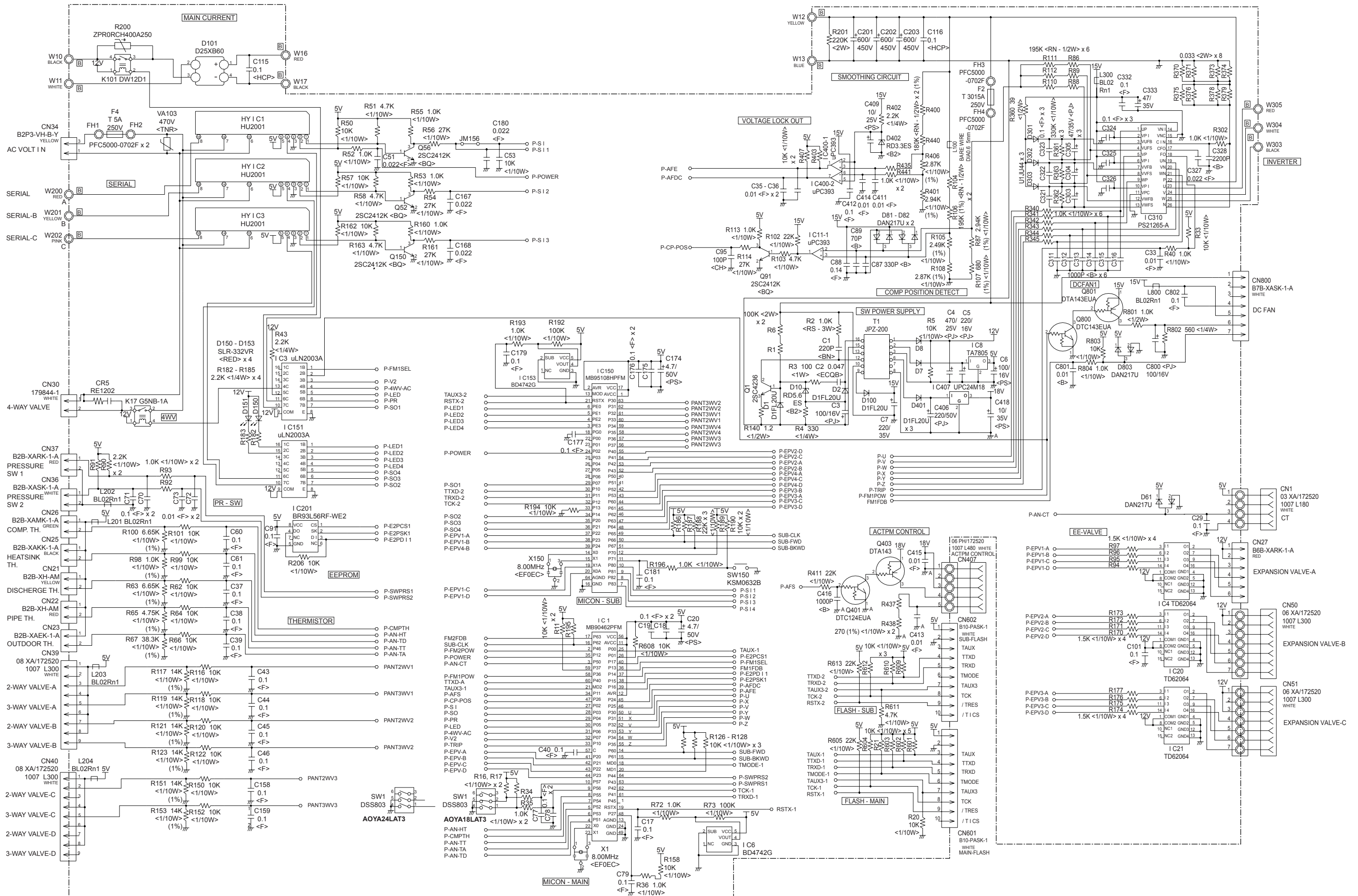

# OUTDOOR UNIT

## POWER SUPPLY PCB ASSEMBLY K04BA-0505HUE-P0

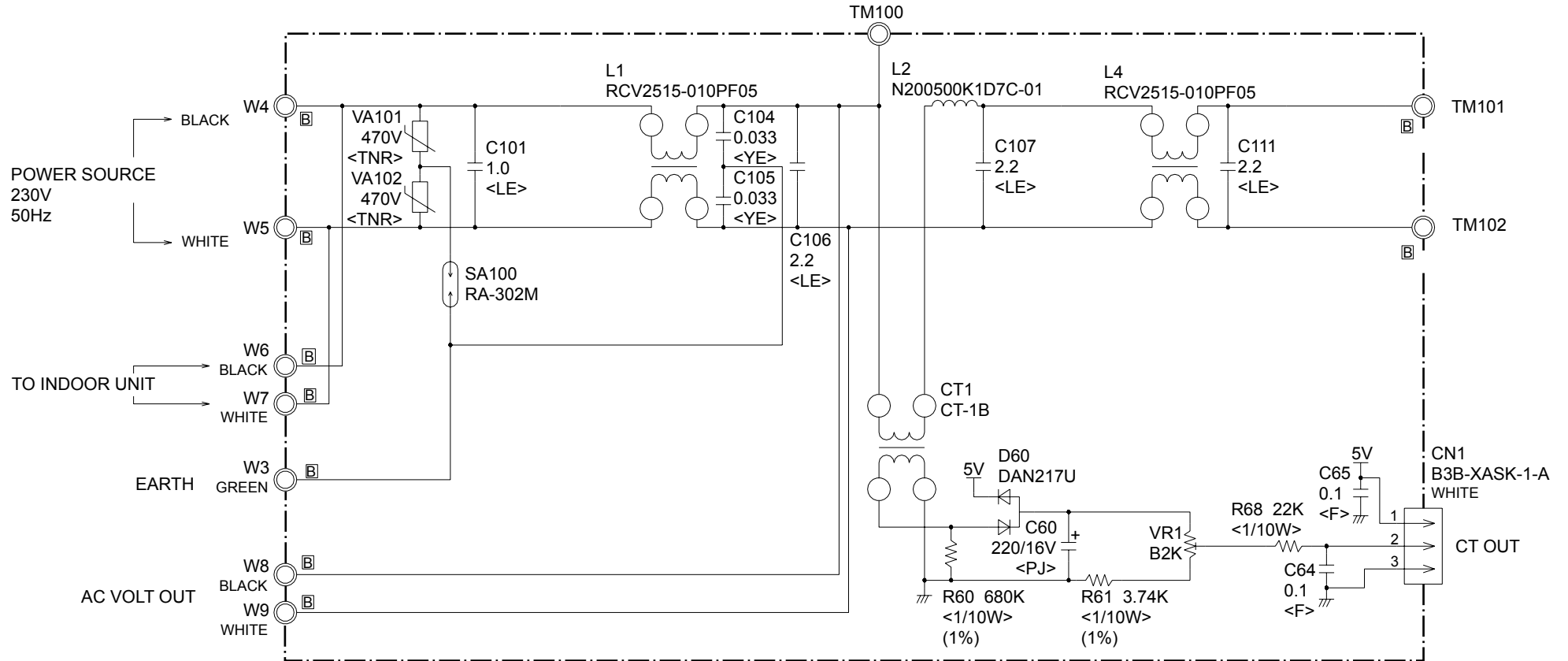

# ERROR CONTENTS

## INDOOR UNIT

Error contents		Error display Indoor unit LED			
		OPERATION (Red)	TIMER (Green)	AIR CLEAN or QUIET (Green)	COIL DRY (Orange)
Communication error	Indoor unit - Outdoor unit	off	2 - 5 flashes	off	off
Indoor unit temperature error	Room temp. sensor error	2 flashes	2 flashes	off	off
	Heat exchanger temp. sensor error	2 flashes	3 flashes	off	off
Outdoor unit temperature error	Discharge pipe temp. sensor error	3 flashes	2 flashes	off	off
	Heat exchanger temp. sensor error	3 flashes	3 flashes	off	off
	Outdoor temp. sensor error	3 flashes	4 flashes	off	off
	2 way valve temp. sensor error	3 flashes	off	2 flashes	off
	3 way valve temp. sensor error	3 flashes	off	3 flashes	off
	Heat sink temp. sensor error	3 flashes	7 flashes	off	off
Indoor unit control system error	Compressor temp. sensor error	3 flashes	8 flashes	off	off
	MANUAL AUTO button error	4 flashes	2 flashes	off	off
	50Hz / 60Hz distinguish error	4 flashes	4 flashes	off	off
	Electronic Air clean filter error	4 flashes	7 flashes	off	off
Outdoor unit control system error	Electronic Air clean filter error	4 flashes	8 flashes	off	off
	Current trip error	5 flashes	2 flashes	off	off
	CT error	5 flashes	3 flashes	off	off
	Compressor position error	5 flashes	5 flashes	off	off
	Fan motor error	5 flashes	6 flashes	off	off
	Connected indoor unit error	5 flashes	7 flashes	off	off
Indoor unit fan motor error	Main CPU - sub CPU communication error	5 flashes	8 flashes	off	off
	Fan motor error	6 flashes	2 flashes	off	off
Refrigerant system error	Fan motor error	6 flashes	3 flashes	off	off
	Discharge pipe temp. error	7 flashes	2 flashes	off	off
	High pressure error	7 flashes	3 flashes	off	off
Added function error	High pressure switch error	7 flashes	6 flashes	off	off
	Active filter error	8 flashes	2 - 3 flashes	off	off
Indoor unit connect error	Indoor unit model error	blinking	blinking	blinking	blinking

## OUTDOOR UNIT LEDS

	LED A	LED B	LED C
Communication error (indoor unit A to outdoor unit)	● 1 time	—	—
Communication error (indoor unit B to outdoor unit)	—	● 1 time	—
Communication error (indoor unit C to outdoor unit)	—		● 1 time
Discharge pipe temperature sensor	● 2 times	—	—
Outdoor heat exchanger temperature sensor	● 3 times	—	—
Outdoor temperature sensor	● 4 times	—	—
Outdoor 2way valve(A) temperature sensor	● 5 times	—	—
Outdoor 2way valve(B) temperature sensor	—	● 5 times	—
Outdoor 2way valve(C) temperature sensor	—	—	● 5 times
Outdoor 3way valve(A) temperature sensor	● 6 times	—	—
Outdoor 3way valve(B) temperature sensor	—	● 6 times	—
Outdoor 3way valve(C) temperature sensor	—	—	● 6 times
Compressor temperature sensor	● 7 times	—	—
Heatsink temperature sensor	● 8 times	—	—
Pressure switch A abnormal	● 9 times	—	—
Pressure switch B abnormal	● 10 times	—	—
Indoor unit connection capacity error	● 11 times	—	—
IPM error	● 12 times	—	—
Compressor loter location error	● 13 times	—	—
Compressor can not start to operate	● 14 times	—	—
Outdoor fan (upper) motor error	● 15 times	—	—
Outdoor fan (lower) motor error	● 16 times	—	—
Microcomputer error	● 17 times	—	—
4way valve (Solenoid) abnormal	● 18 times	—	—

● : Slow flashing - : Off



# DISASSEMBLY ILLUSTRATION

## INDOOR UNIT

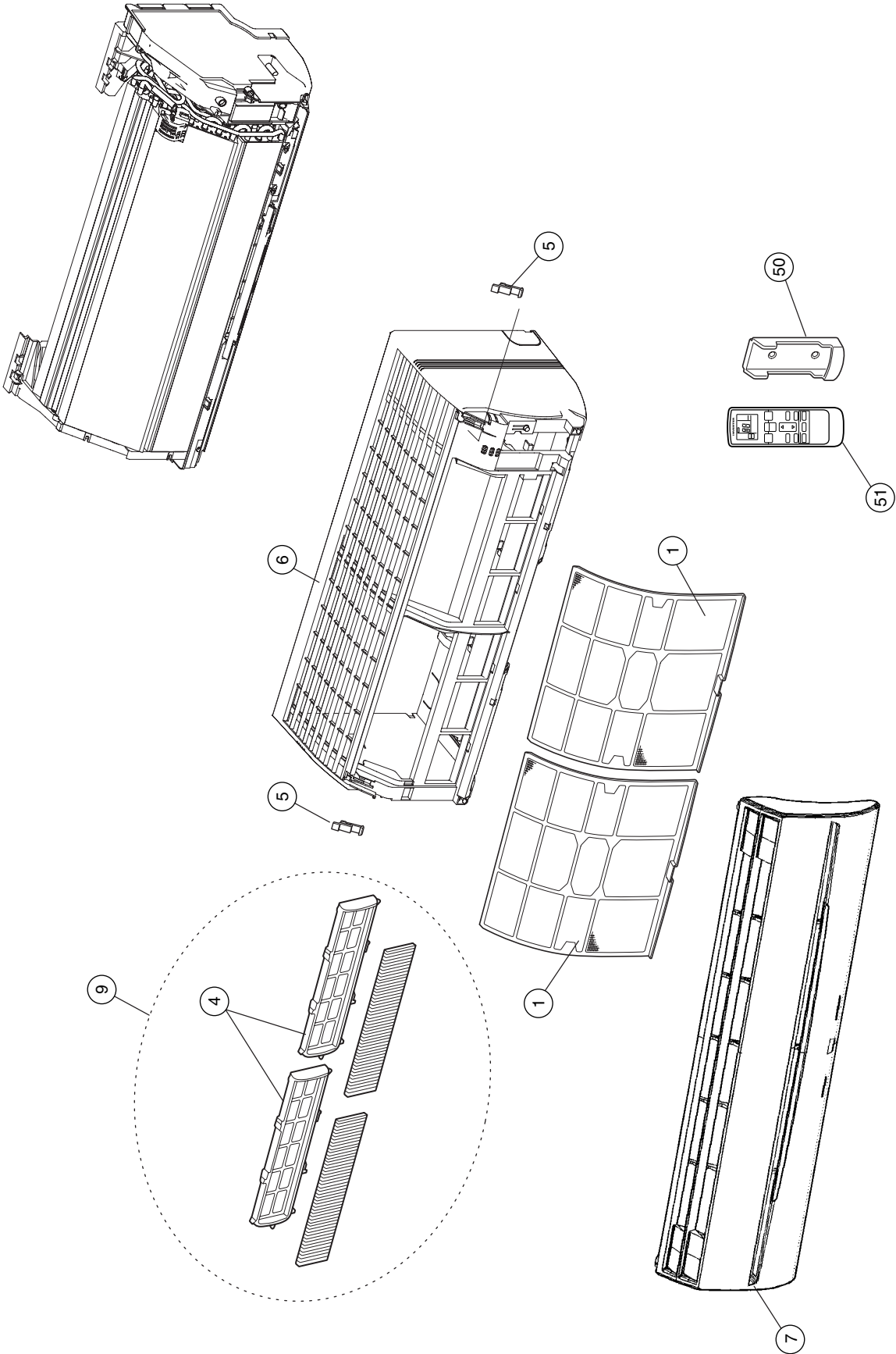

# INDOOR UNIT

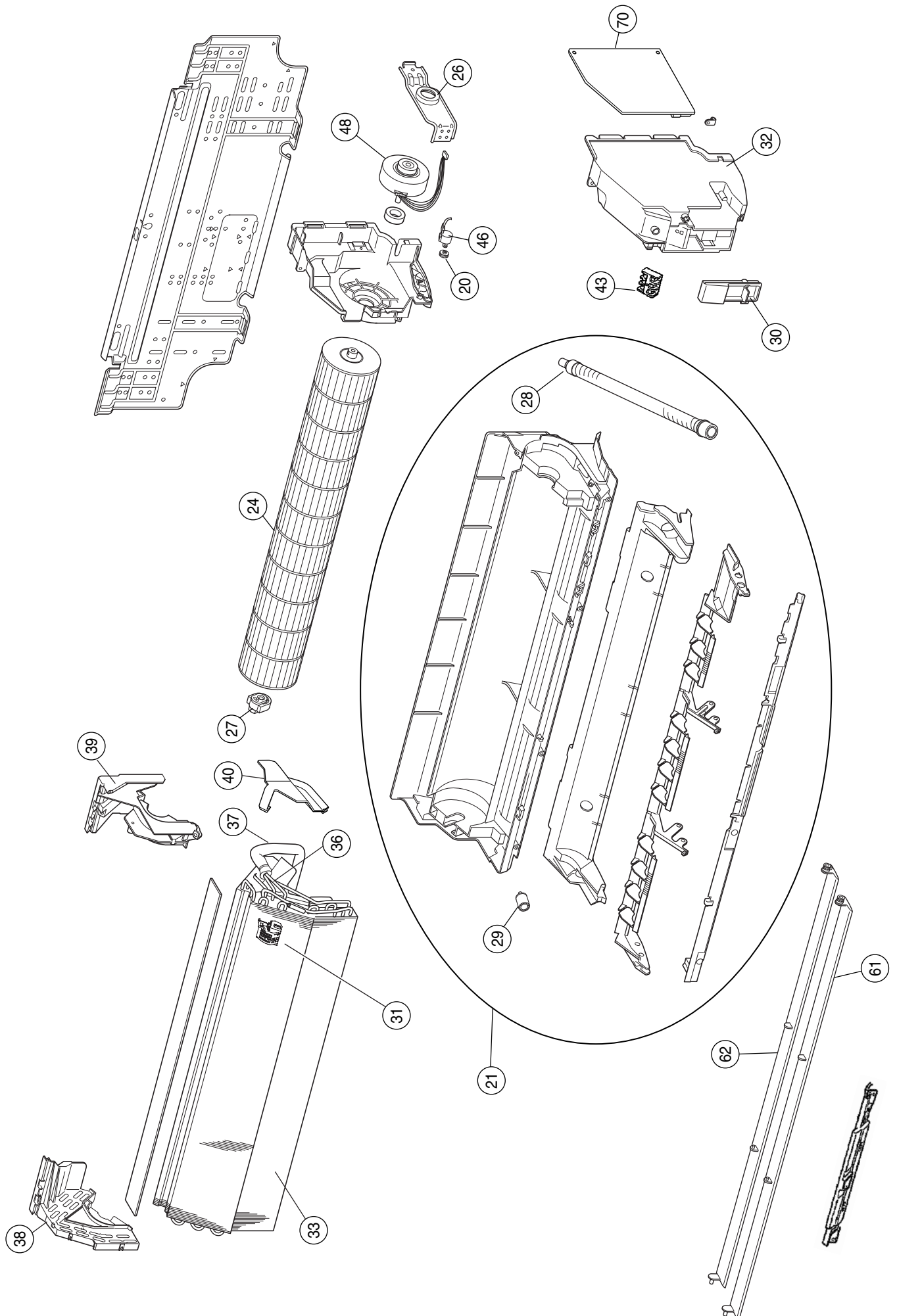

# OUTDOOR UNIT

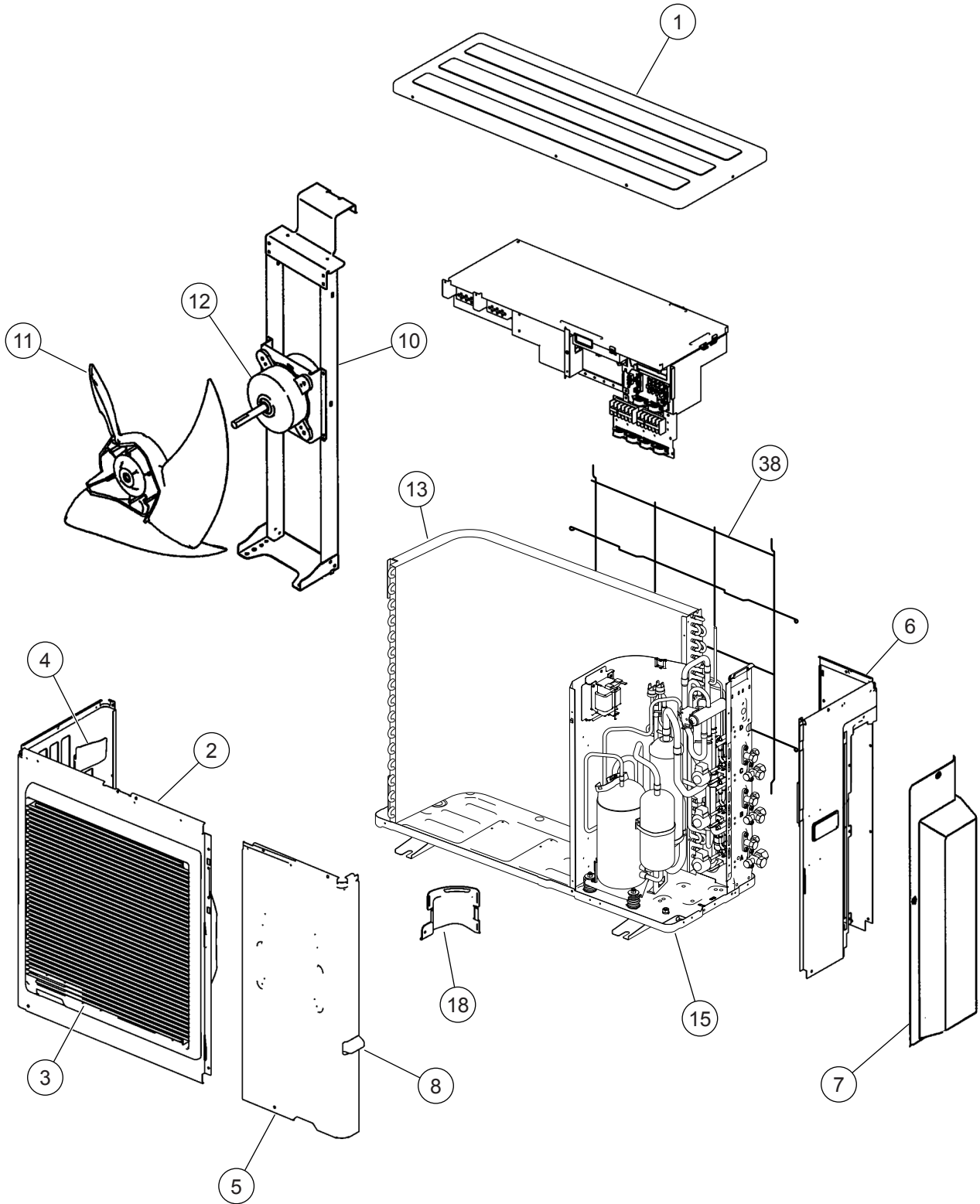

# OUTDOOR UNIT

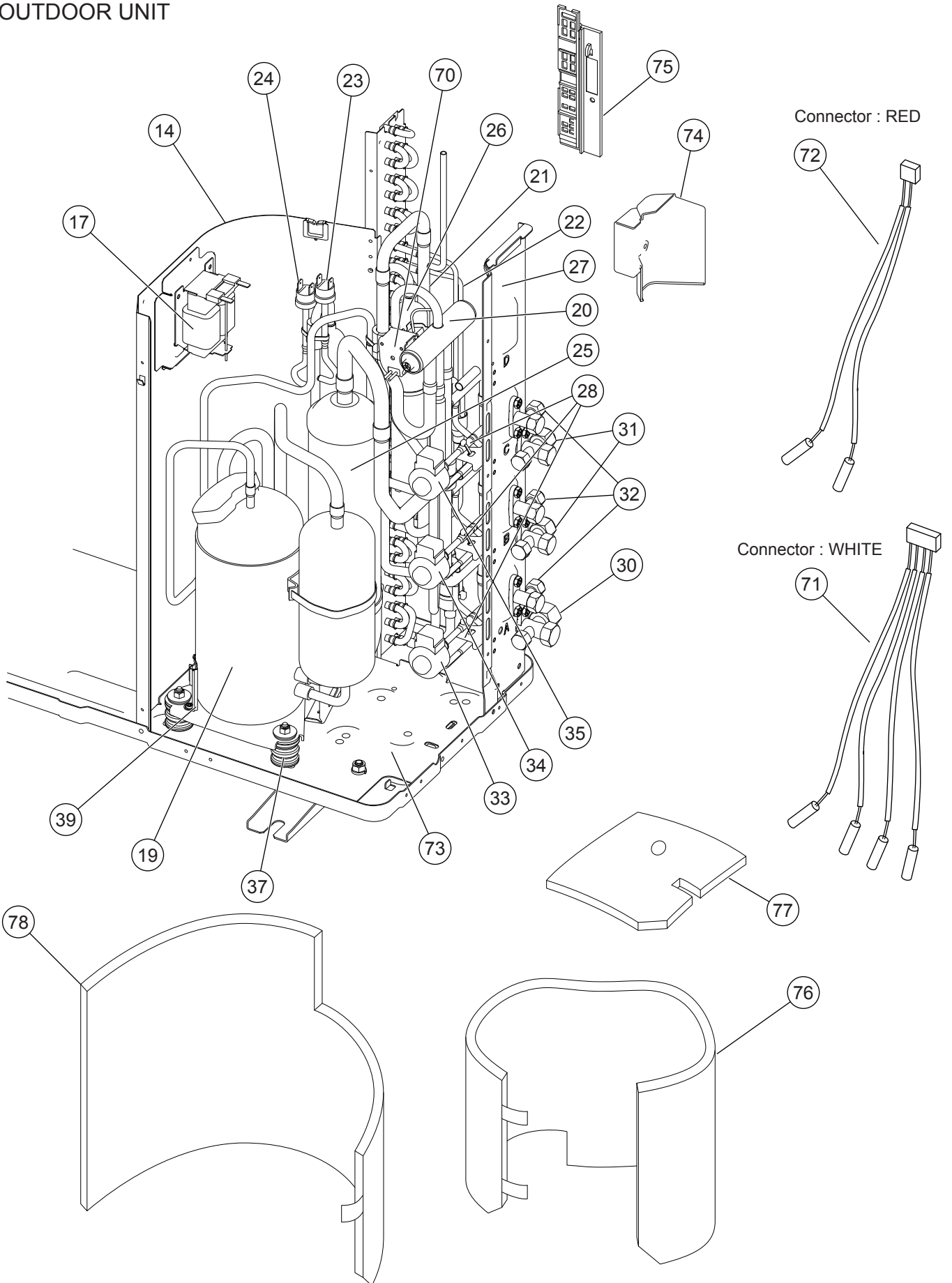

OUTDOOR UNIT  
INVERTER ASSY

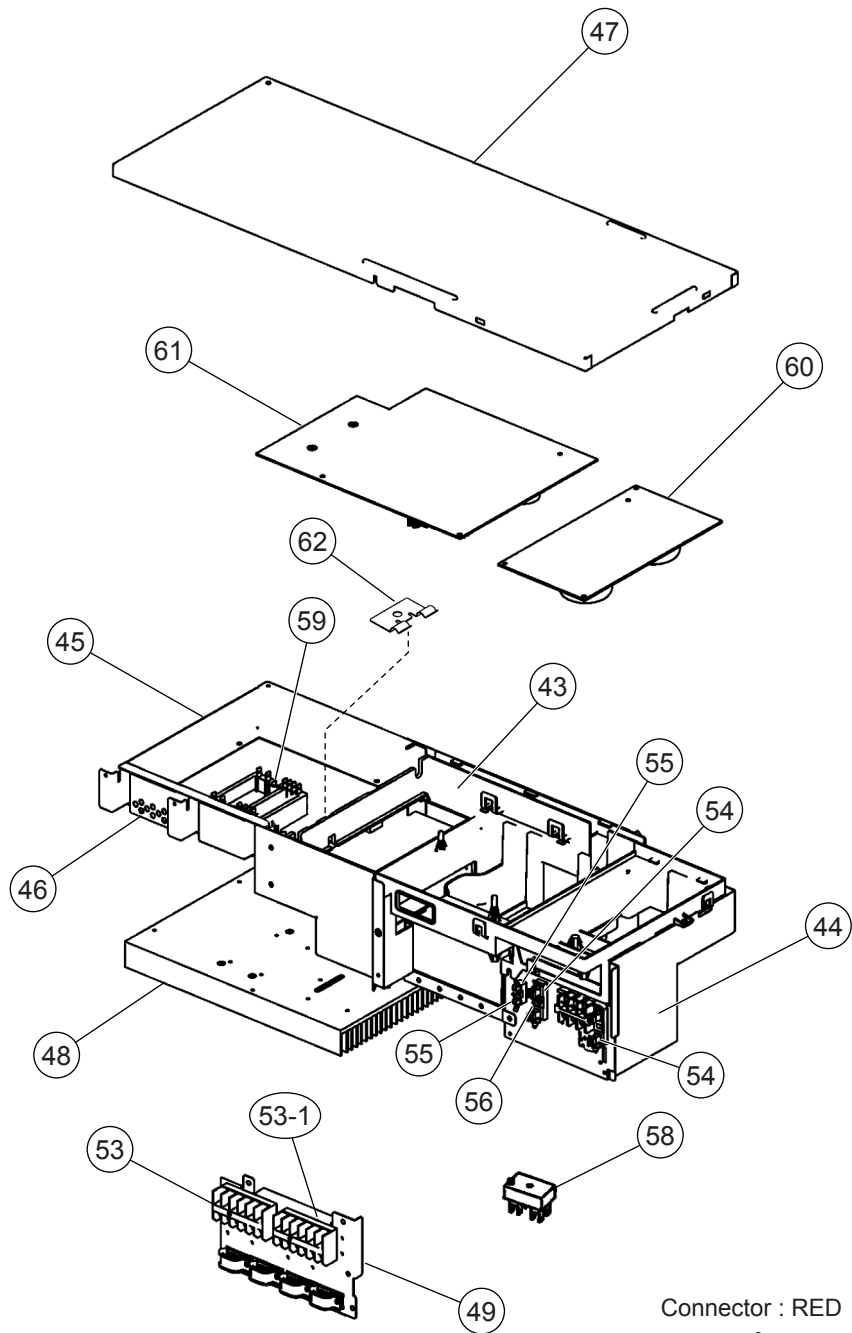

Connector : BLACK

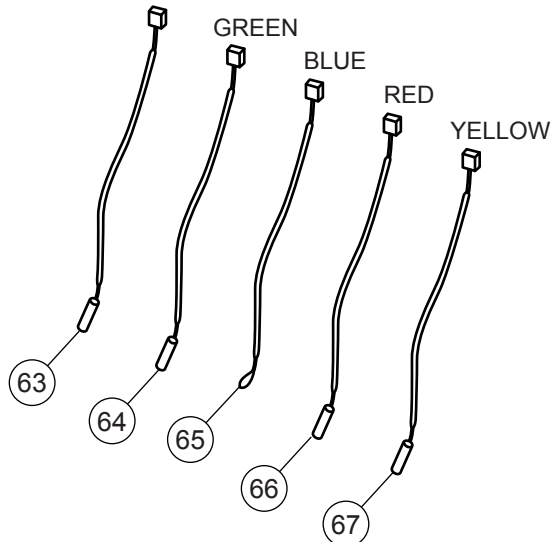

Connector : RED

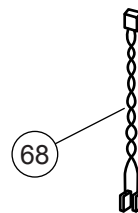

WHITE

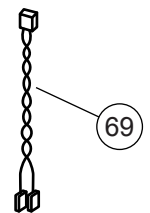

# PARTS LIST

## INDOOR UNIT





Ref. No.	Description	Part No.		Ord. Q'ty
		ASHA14LACM	ASHA18LACM	
1	Air Filter	9309997011	9309997011	
4	Electric Filter Holder	9306602017	9306602017	
5	Clamper (Grille)	9306755010	9306755010	
6	Front Panel	9309999053	9309999053	
7	Intake Grille Assy	9313131142	9313131142	
9	Air Clean Filter Assy	9312152018	9312152018	
20	Gear-A	9309994003	9309994003	
21	Casing Assy	9311354116	9311354116	
24	Crossflow Fan Assy	9307836015	9307836015	
26	Clamp (Motor)	9310102008	9310102008	
27	Shaft Holder-C Assy	9306628017	9306628017	
28	Drain Hose Assy	9314147012	9314147012	
29	Drain Cap Assy	9314493010	9314493010	
30	Wire Clamper	9313944018	9313944018	
31	Holder (Room Thermistor)	9311948018	9311948018	
32	Cover (Switch)	9313943011	9313943011	
33	Evaporator Total Assy	9313099015	9313099015	
36	Joint Pipe Assy	9313104030	9313792015	
37	Insulation (Pipe)-E	9304607007	9304607007	
38	Holder (Evaporator)-L	9309982017	9309982017	
39	Holder (Evaporator)-R	9309983014	9309983014	
40	Water Seal	9312912018	9312912018	
43	Terminal	9701955114	9701955114	
46	Step Motor	9900139025	9900139025	
48	Fan Motor Assy	9602109012	9602109012	
50	Remote Control Holder	9305642045	9305642045	
51	Remote Control Unit	9315027030	9315027030	
61	Louver U	9309991033	9309991033	
62	Louver Z	9309992030	9309992030	
70	Controller PCB Assy	9707404043	9707404050	
---	Pipe Temperature Thermistor	9702039042	9702039042	
---	Room Temperature Thermistor	9700801108	9700801108	
---	Indicator PCB Assy	9705039032	9705039032	
---	Evaporator B Assy	-----	9311275022	

## OUTDOOR UNIT



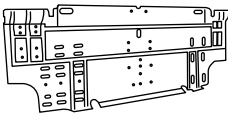
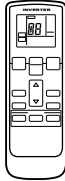

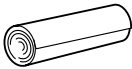
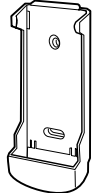
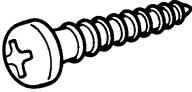
Ref. No.	Description	Part No.		Ref. No.	Description	Part No.		Ord. Q'ty
		AOHA18LAT3	AOHA24LAT3			AOHA18LAT3	AOHA24LAT3	
1	Top Panel Sub Assy	9374417049		45	Inverter Box C	9375140014		
2	Front Panel Sub Assy	9374414048		46	Inverter Box Duct	9374609017		
5	Service Panel Sub Assy	9374415045		47	Inverter Box Cover	9375139018		
6	Right Panel Sub Assy	9374416103		48	Heat Sink A	9375138011		
7	Valve Cover Sub Assy	9374827015		49	Inverter Box D	9374606023		
10	Motor Bracket Sub Assy	9374418060		52	Terminal (3P)	9900203016		
11	Propeller Fan Assy	9366378020		53	Terminal (6P)	9900016036		
12	Motor. DC Brushless	9601882015		53-1	Terminal (3P)	9306489045		
13	Condenser A Assy	9374433179		54	Fuse Holder (Big)	0501454012		
14	Separate Wall Assy SS	9375226022		55	Fuse Holder (Small)	0501456016		
15	Base Assy	9374166121		56	Fuse (Big)	0600086039		
17	Coil. Choke	9900366018		57	Fuse (Small)	0600376116		
18	Cap Foot	9374345014		58	Terminal (2P)	9701971015		
19	Compressor Assy	9315297037		59	ACTPM	9703457012		
20	4-Way Valve Assy	9374425136		60	Power Supply PCB Assy	9705647091		
21	Inlet Pipe (Cond) A Assy	9373461104		61	Controller PCB Assy (AOYA18L)	9705642225		
22	Outlet Pipe (Cond) A Assy	9374266111		61	Controller PCB Assy (AOYA24L)	9705642195		
23	Pressure Switch A	9900186012		62	Holder (Thermo)	9372797013		
24	Pressure Switch B	9900341015		63	Heat Sink Thermistor	9900311018		
25	Accumulator Assy	9375250027		64	Compressor Temp Thermistor	9900156053		
26	Receiver Tank Assy	9374575039		65	Thermistor (Outdoor Temp)	9900378028		
27	Valve Plate A Assy	9374628148		66	Heat Exchanger Thermistor	9900374020		
28	Pulse Motor Valve	9900056025		67	Discharge Temp Thermistor	9704219039		
30	3-Way Valve Assy (1/2")	9375104016		68	Wire (Pressure Sw) (Red)	9377823014		
31	3-Way Valve Assy (3/8")	9375103019		69	Wire (Pressure Sw) (White)	9377823021		
32	2-Way Valve Assy	9375102012		70	Solenoid	9900165079		
33	Coil (Expansion Valve) (A=Red)	9900057084		71	Thermistor (Pipe)(White)	9900373030		
34	Coil (Expansion Valve) (B=White)	9900057053		72	Thermistor (Pipe)(Red)	9900372019		
35	Coil (Expansion Valve) (C=Green)	9900057060		73	Compressor Plate Assy	9375221058		
37	Rubber Cushion (For Comp)	9312680016		74	Water Seal Plate	9375222017		
38	Net S Protective	9375381028		75	Thermo Holder	9375211011		
39	Thermistor Holder	9377911018		76	Compressor Cover A	9374430093		
43	Inverter Box A	9374603015		77	Compressor Cover B	9374431090		
44	Inverter Box B Assy	9374625024		78	Compressor Cover C	9372067079		
				---	Emblem Rear	9372171011		

# STANDARD ACCESSORIES

## INDOOR UNIT

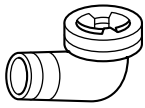
Name and Shape	Q'ty	Use	Part No.
Wall hook bracket 	1	For indoor unit installation	9310001004
Remote control unit 	1	Use for air conditioner operation	9315027030
Battery (penlight) 	2	For remote control unit	0600185527
Cloth tape 	1	For indoor unit installation	9310519004
Remote control unit holder 	1	Use as remote control unit holder	9305642045
Tpping screw (big) ( φ 4 x 25) 	8	For wall hook bracket installation	0700076046
Tpping screw (small) ( φ 3 x 12) 	2	For remote control unit holder installation	0700019036

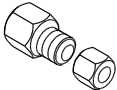
## OUTDOOR UNIT

Name and Shape	Q'ty	Use	Part No.
Drain pipe 	1	For outdoor unit drain piping work	9303029015
Drain cap 	2		313166024302
Adapter assy 12.7 mm → 9.52 mm (1/2 in.) (3/8 in.) 	1	For use when connecting models 9-12 to outdoor port A	9370244007
Putty 	1	For sealing	303020200114



0610G3157