



**SPLIT TYPE
ROOM AIR CONDITIONER
WALL MOUNTED type**

**SERVICE
MANUAL**



Models

Indoor unit

Outdoor unit

ASHA07LCC

AOHR07LCC

ASHA09LCC

AOHR09LCC

CONTENTS

SPECIFICATIONS..... 1
DIMENSIONS..... 2
REFRIGERANT SYSTEM DIAGRAM..... 3
CIRCUIT DIAGRAM..... 4
INDOOR PCB CIRCUIT DIAGRAM..... 5
OUTDOOR PCB CIRCUIT DIAGRAM ... 6
ERROR CONTENTS..... 8
DISASSEMBLY ILLUSTRATION..... 9
PARTS LIST..... 14
STANDARD ACCESSORIES 16

SPECIFICATIONS

TYPE	COOL & HEAT INVERTER	
INDOOR UNIT	ASHA07LCC	ASHA09LCC
OUTDOOR UNIT	AOHR07LCC	AOHR09LCC
COOLING CAPACITY	2.10 kW	2.60 kW
HEATING CAPACITY	3.00 kW	3.60 kW

ELECTRICAL DATA

POWER SOURCE		230 V	230 V
FREQUENCY		50 Hz	50 Hz
RUNNING CURRENT	COOLING	2.5 A	3.2 A
	HEATING	3.2 A	4.0 A
INPUT WATTS	COOLING	0.47 kW	0.655 kW
	HEATING	0.66 kW	0.845 kW
E.E.R.	COOLING	4.47 kW/kW	3.97 kW/kW
COP	HEATING	4.55 kW/kW	4.26 kW/kW
MOISTURE REMOVAL		1.0 L/hr	1.3 L/hr
AIR CIRCULATION -High	COOLING	595 m ³ /hr	595 m ³ /hr
	HEATING	645 m ³ /hr	645 m ³ /hr

COMPRESSOR

TYPE	Hermetic type, 4 pole, 3 phase, DC inverter motor, Rotary
DISCRIMINATION	DA89X1C - 20FZ
REFRIGERANT R410A	900 g

FAN MOTOR

POWER SOURCE	230 V	
INDOOR UNIT	HIGH-SPEED	Cool 1,300 / Heat 1,390 r.p.m.
	MED-SPEED	Cool 1,120 / Heat 1,200 r.p.m.
	LOW-SPEED	Cool 950 / Heat 1,000 r.p.m.
	QUIET	Cool 700 / Heat 760 r.p.m.
OUTDOOR UNIT	800 r.p.m.	

DIMENSIONS

INDOOR UNIT	H x W x D	275 x 790 x 215 mm
OUTDOOR UNIT	H x W x D	540 x 660 x 290 mm

WEIGHT

INDOOR UNIT	GROSS / NET	12 / 9 kg
OUTDOOR UNIT	GROSS / NET	35 / 32 kg

NOISE LEVEL

INDOOR UNIT	High	Cool 41 dB / Heat 41 dB
	Med	Cool 36 dB / Heat 36 dB
	Low	Cool 30 dB / Heat 30 dB
	Quiet	Cool 21 dB / Heat 21 dB
OUTDOOR UNIT		Cool 47 dB / Heat 48 dB

REFRIGERANT (R410A)

	Pipe Length	15 m	900 g
FULL CHARGE AMOUNT		20 m	1,000 g
	ADDITIONAL REFRIGERANT		20 g / m
MAXIMUM PIPING HEIGHT		15m	

DIMENSIONS

Models :
ASHA07LCC / AOHR07LCC
ASHA09LCC / AOHR09LCC
(unit : mm)

INDOOR UNIT

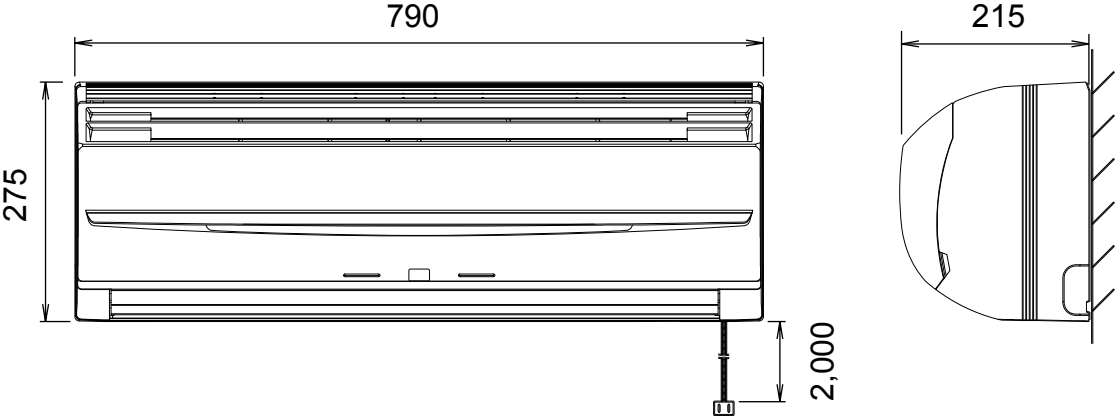

OUTDOOR UNIT

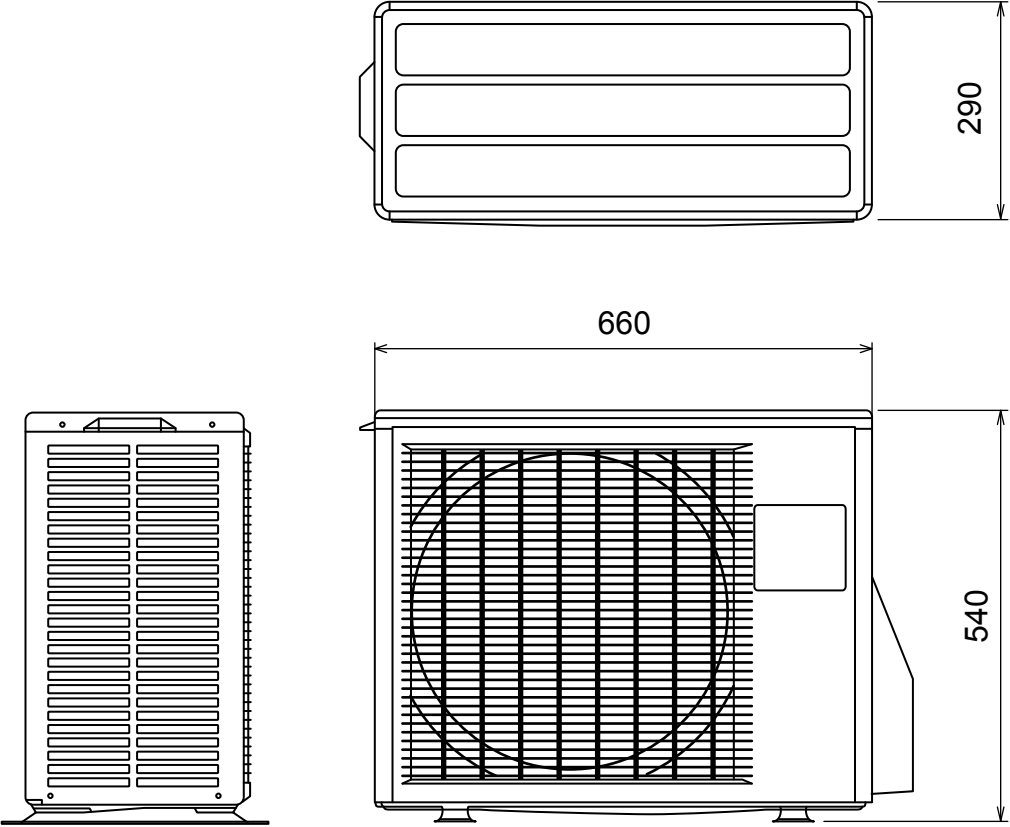

REFRIGERANT SYSTEM DIAGRAM

Models :
 ASHA07LCC / AOHR07LCC
 ASHA09LCC / AOHR09LCC

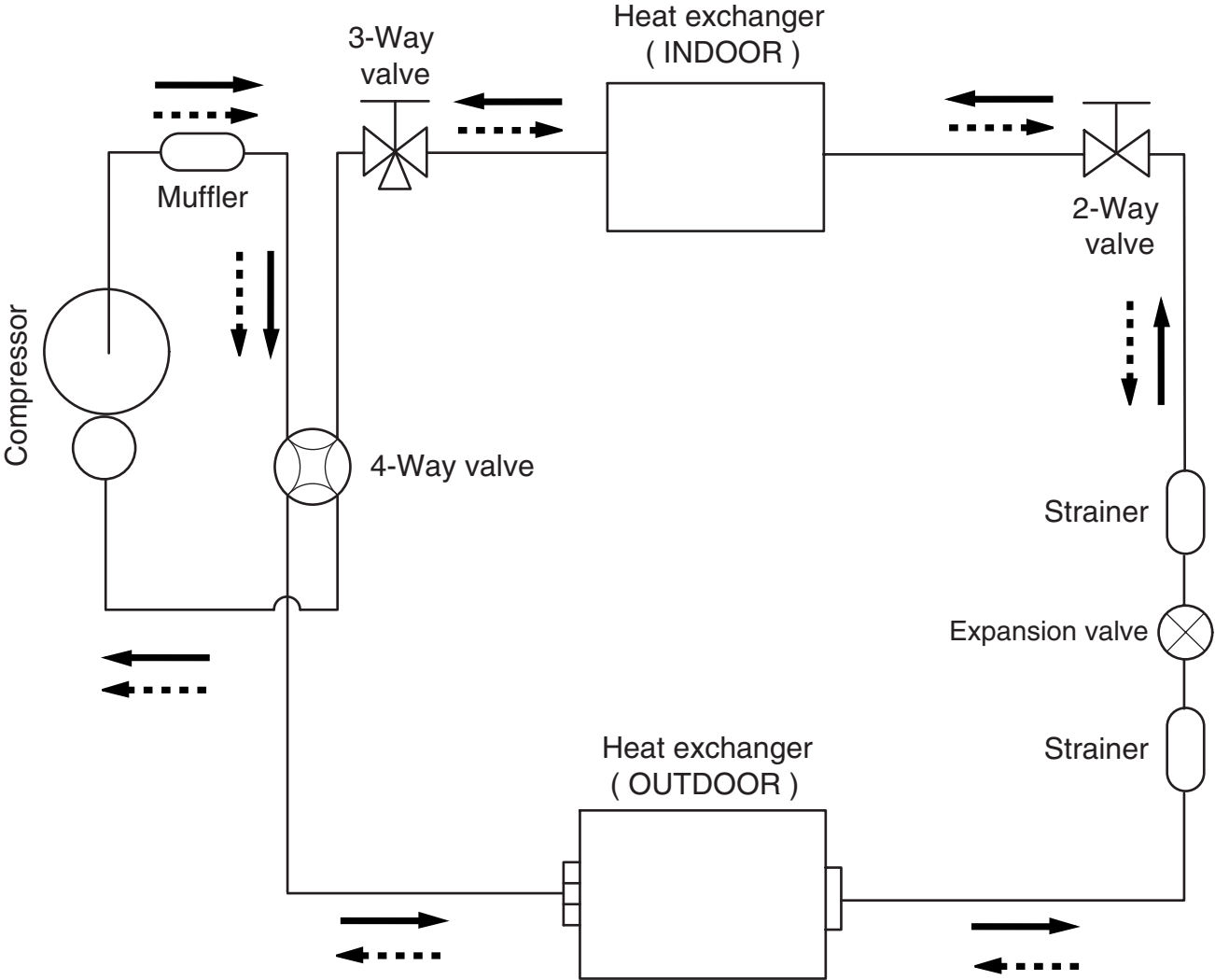

Cooling
 Heating

Refrigerant pipe diameter
 Liquid : 1/4" (6.35 mm)
 Gas : 3/8" (9.52 mm)

CIRCUIT DIAGRAM

Models :

ASHA07LCC / AOHR07LCC

ASHA09LCC / AOHR09LCC

INDOOR UNIT

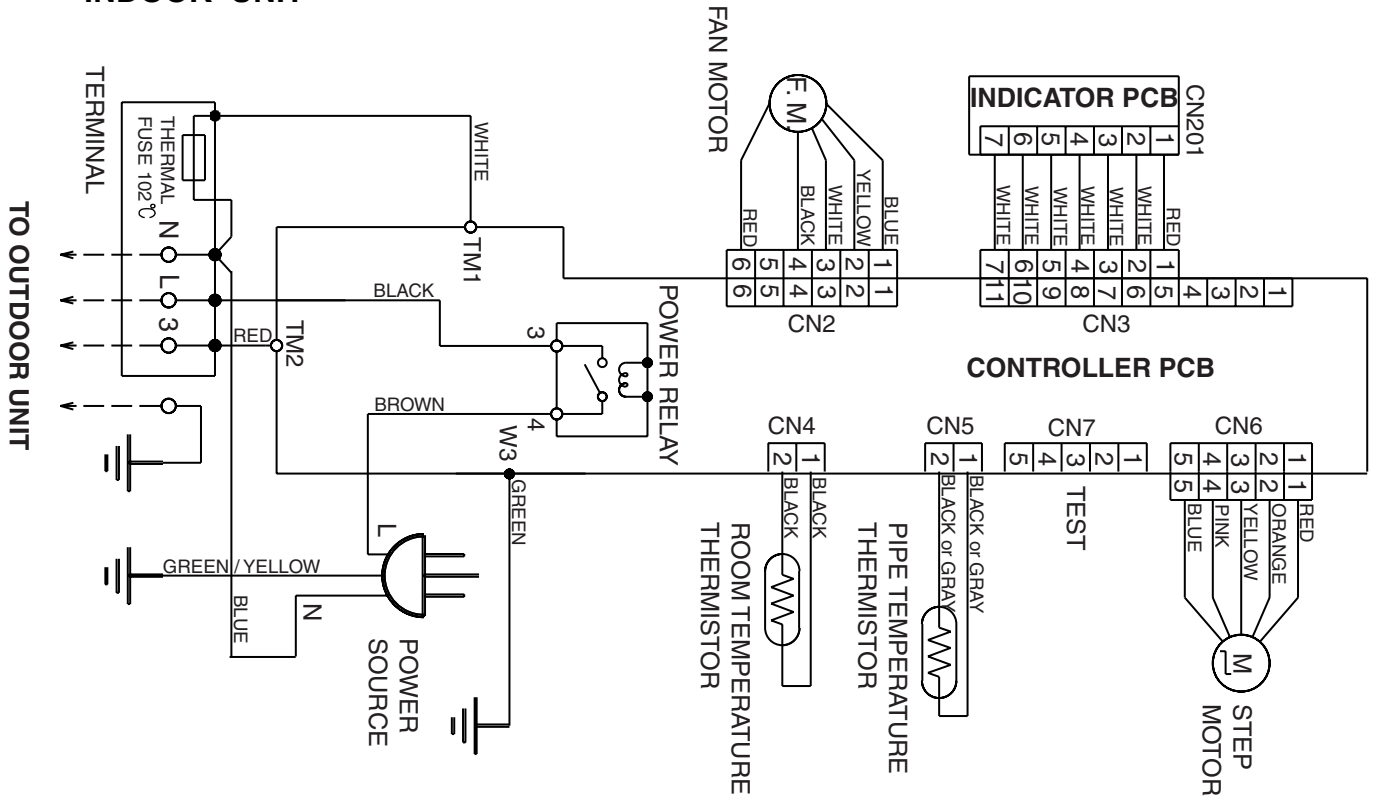

OUTDOOR UNIT

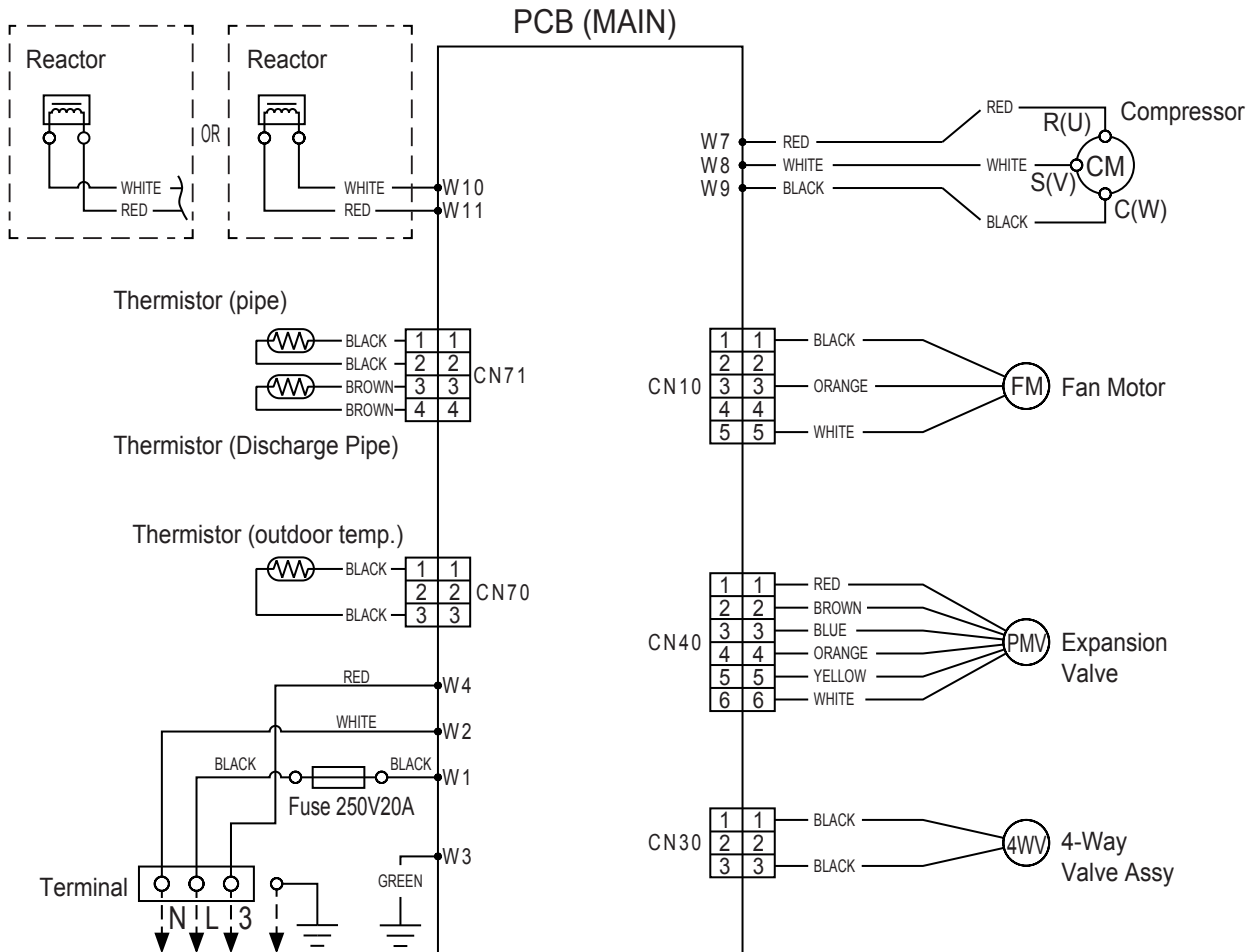

INDOOR PCB CIRCUIT DIAGRAM

Models : ASHA07LCC, ASHA09LCC

TERMINAL BOARD

CONTROLLER PCB ASSEMBLY K02DR-0503HSE-C1

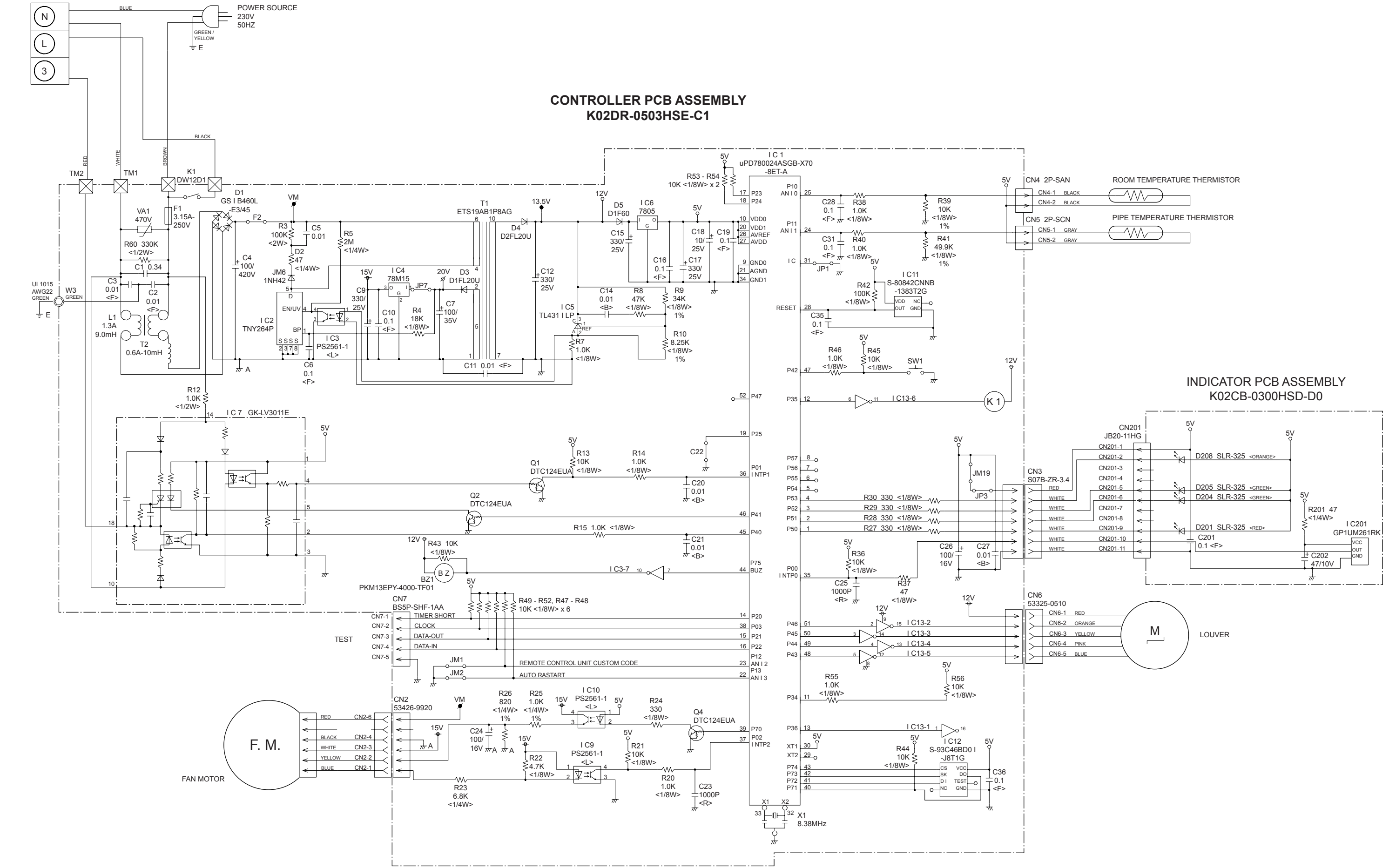

OUTDOOR PCB CIRCUIT DIAGRAM

Models :
 AOHR07LCC
 AOHR09LCC

INVERTER ASSEMBLY
 AOHR07LCC : EZ-00506HUE
 AOHR09LCC : EZ-0053HUE

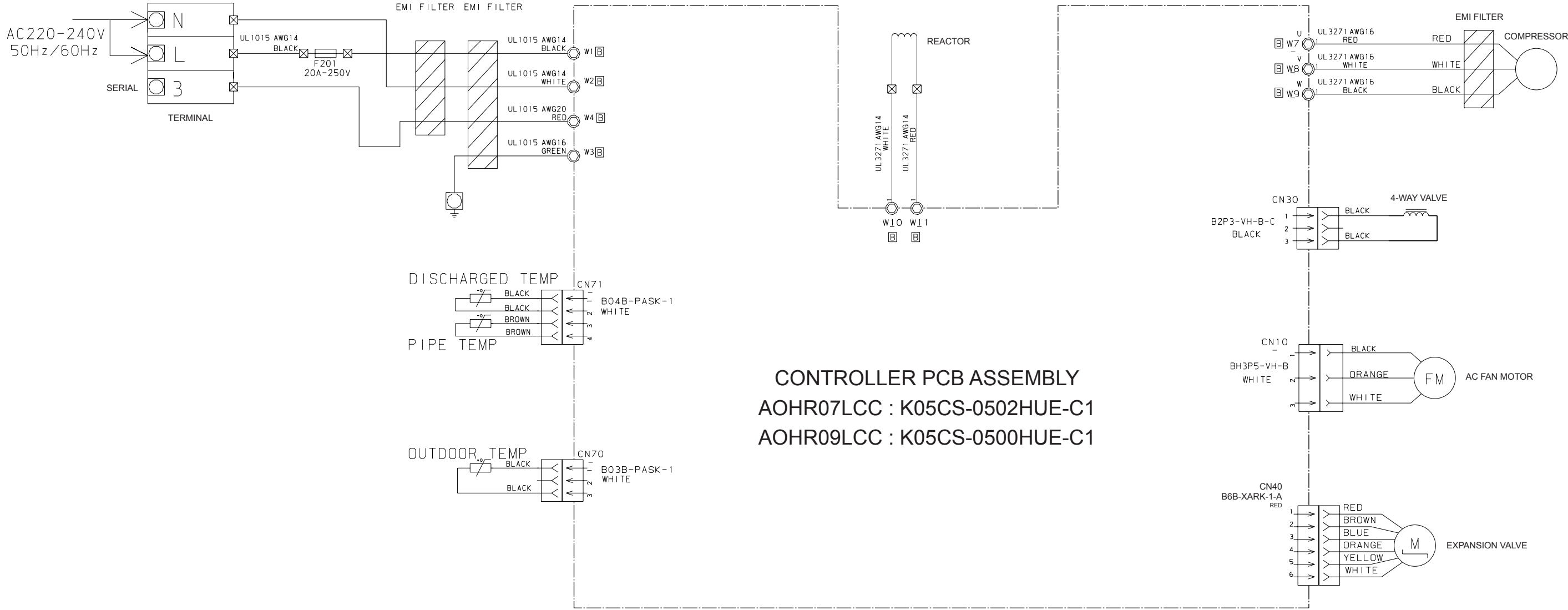

CONTROLLER PCB ASSEMBLY
 AOHR07LCC : K05CS-0502HUE-C1
 AOHR09LCC : K05CS-0500HUE-C1

Models :
AOHR07LCC
AOHR09LCC

CONTROLLER PCB ASSEMBLY
AOYR07LCC : K05CS-0502HUE-C1
AOYR09LCC : K05CS-0500HUE-C1

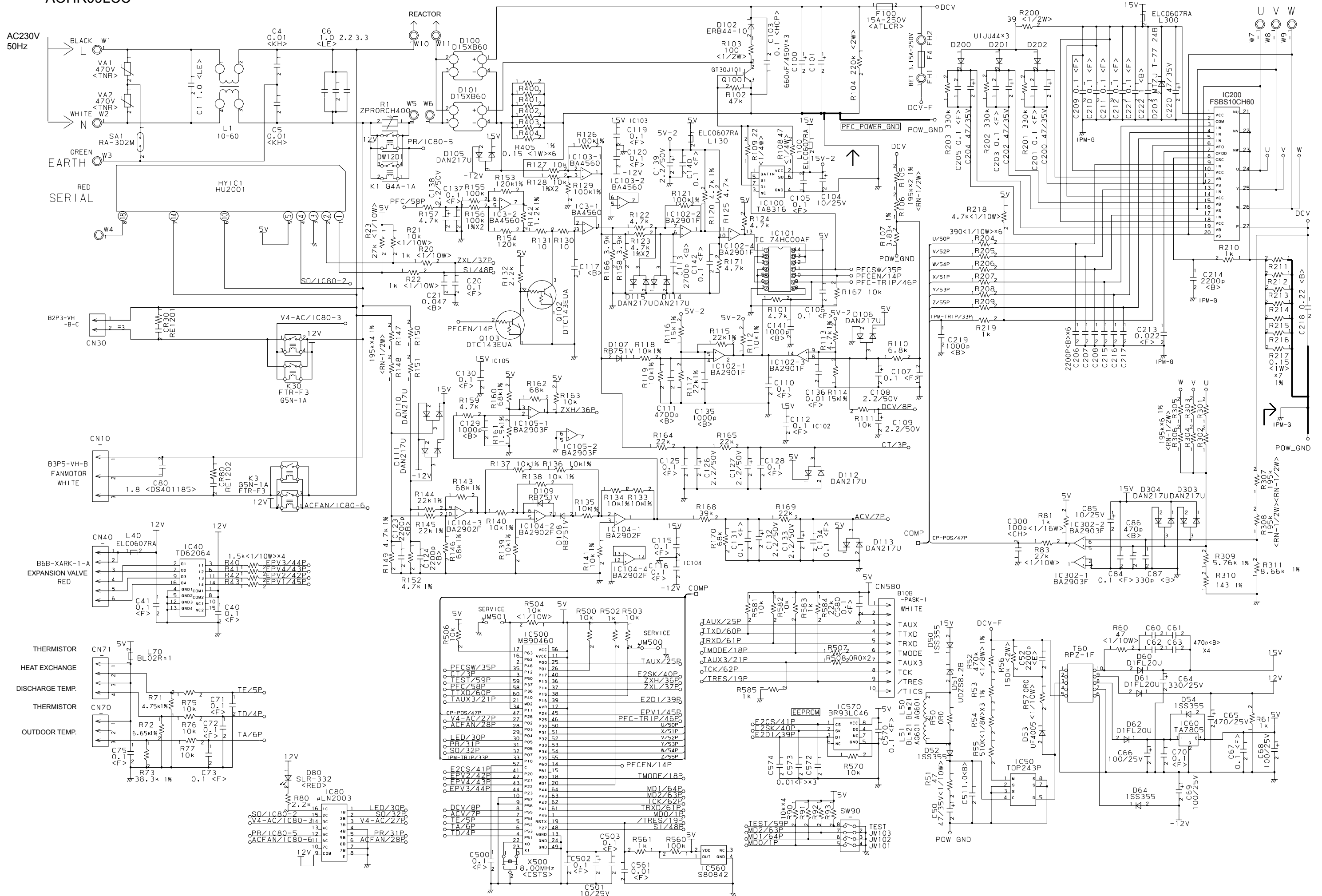

ERROR CONTENTS

Models :
 ASHA07LCC
 ASHA09LCC

Error	Display		Error
	Operation LED	Timer LED	
Serial signal error	Off	2 flash	Serial signal (reverse) error, at operation start up
		3 flash	Serial signal (reverse) error, during operation
		4 flash	Serial signal (forward) error, at operation start up
		5 flash	Serial signal (forward) error, during operation
Indoor unit thermistor error	2 flash	2 flash	Indoor temperature thermistor open / short
		3 flash	Heat exchanger middle thermistor open / short
Outdoor unit thermistor error	3 flash	2 flash	Discharge thermistor open / short
		3 flash	Heat exchanger thermistor open
		4 flash	Outdoor temperature thermistor open / short
Indoor unit control error	4 flash	2 flash	Forced automatic SW welded
		3 flash	Main relay welded
		4 flash	Power interruption error
		7 flash	VDD permanent stop protection
Outdoor unit control error	5 flash	8 flash	reverse VDD permanent stop protection
		2 flash	Current trip error
		3 flash	CT abnormal
		5 flash	Compressor location detection error
Indoor fan motor error	6 flash	6 flash	Outdoor unit fan drive system abnormal
		2 flash	Abnormal lock
Refrigerant cycle error	7 flash	3 flash	Abnormal rotation
		2 flash	Discharge Temperature abnormal
Optional function error	8 flash	3 flash	Cooling high pressure abnormal rise
		4 flash	PFC circuit error
Model information error	0.1 sec on/off	0.1 sec on/off	Model information error

DISASSEMBLY ILLUSTRATION

Model : ASHA07LCC, ASHA09LCC

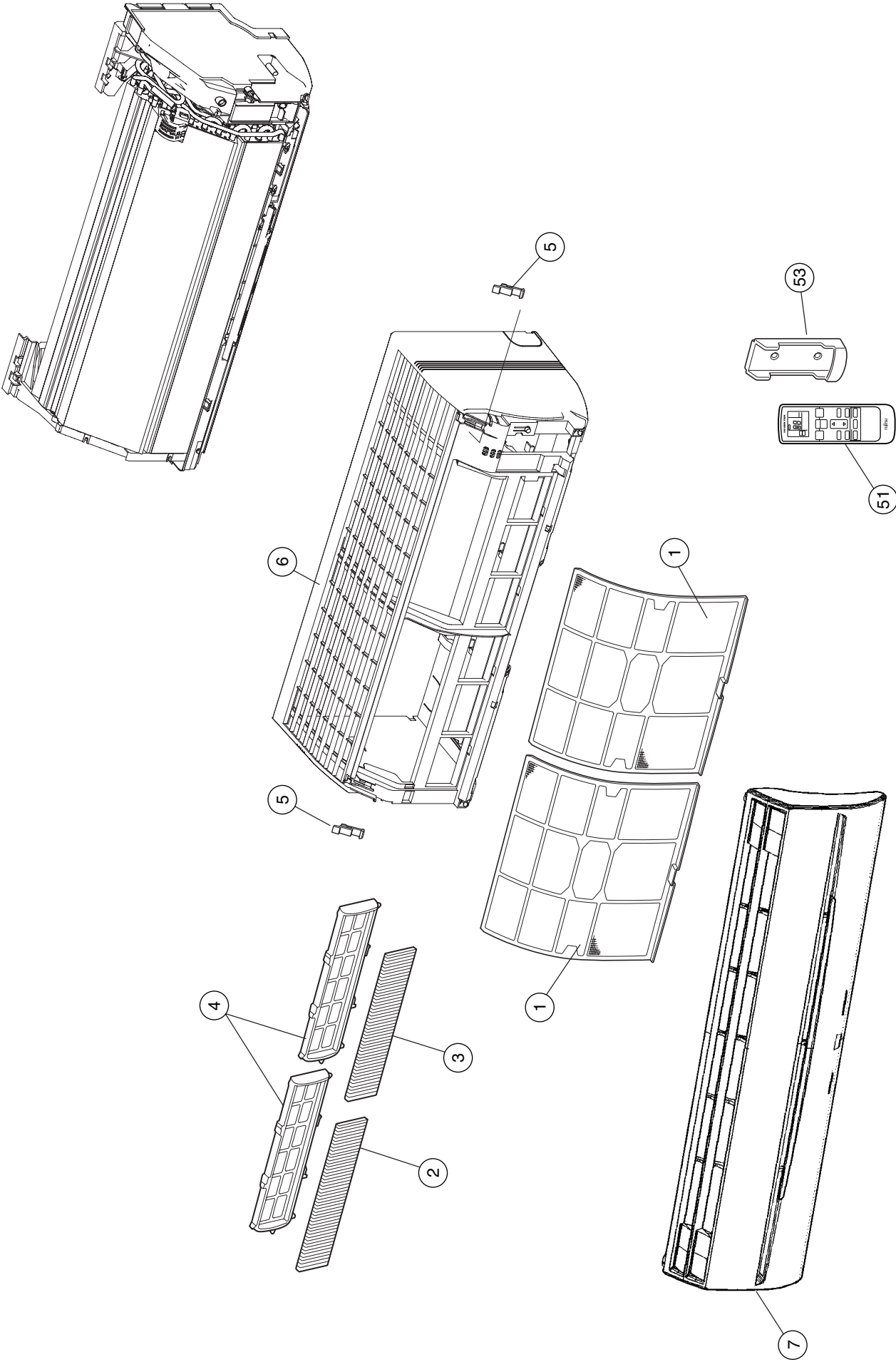

Model : ASHA07LCC, ASHA09LCC

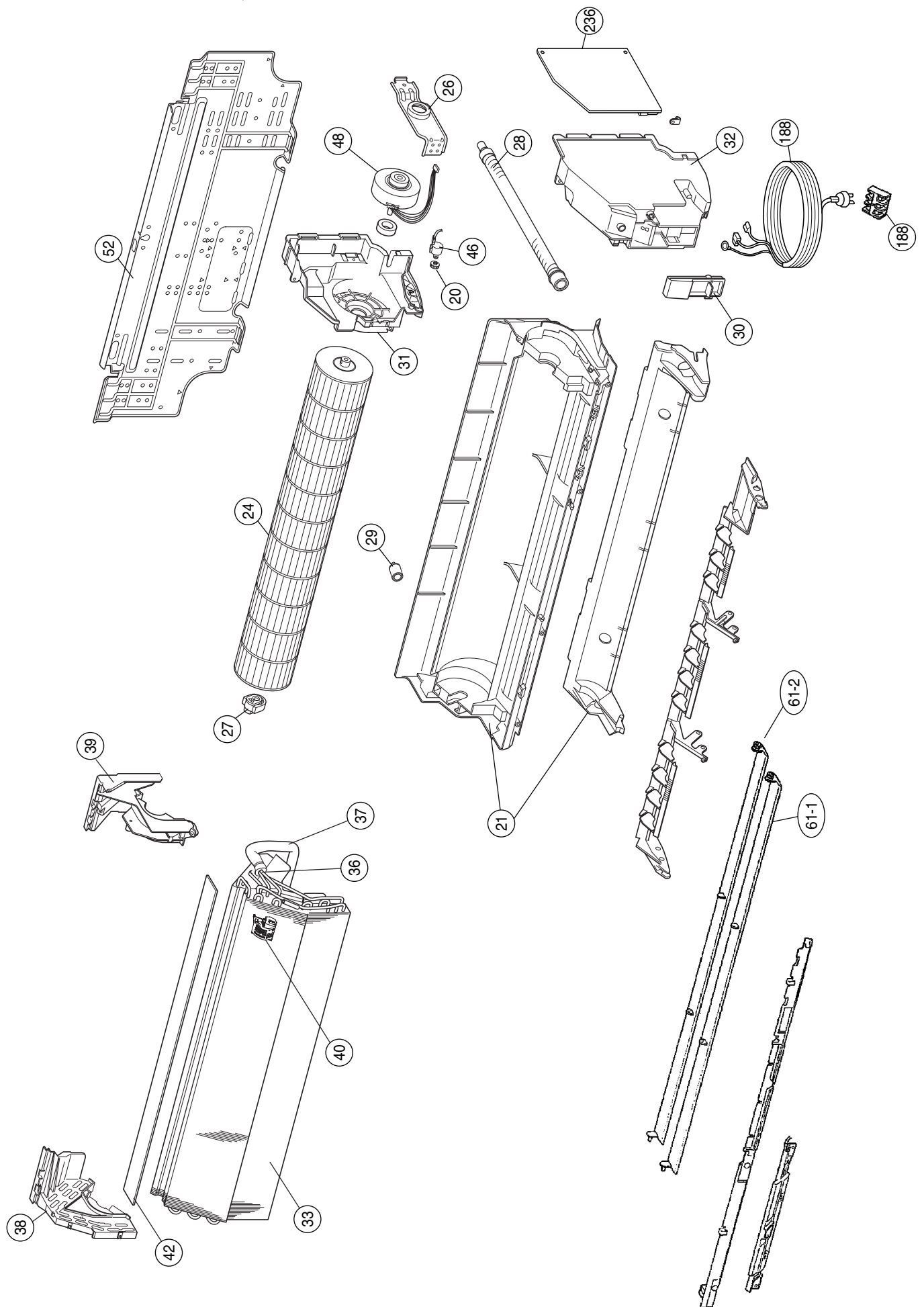

Model : AOHR07LCC, AOHR09LCC

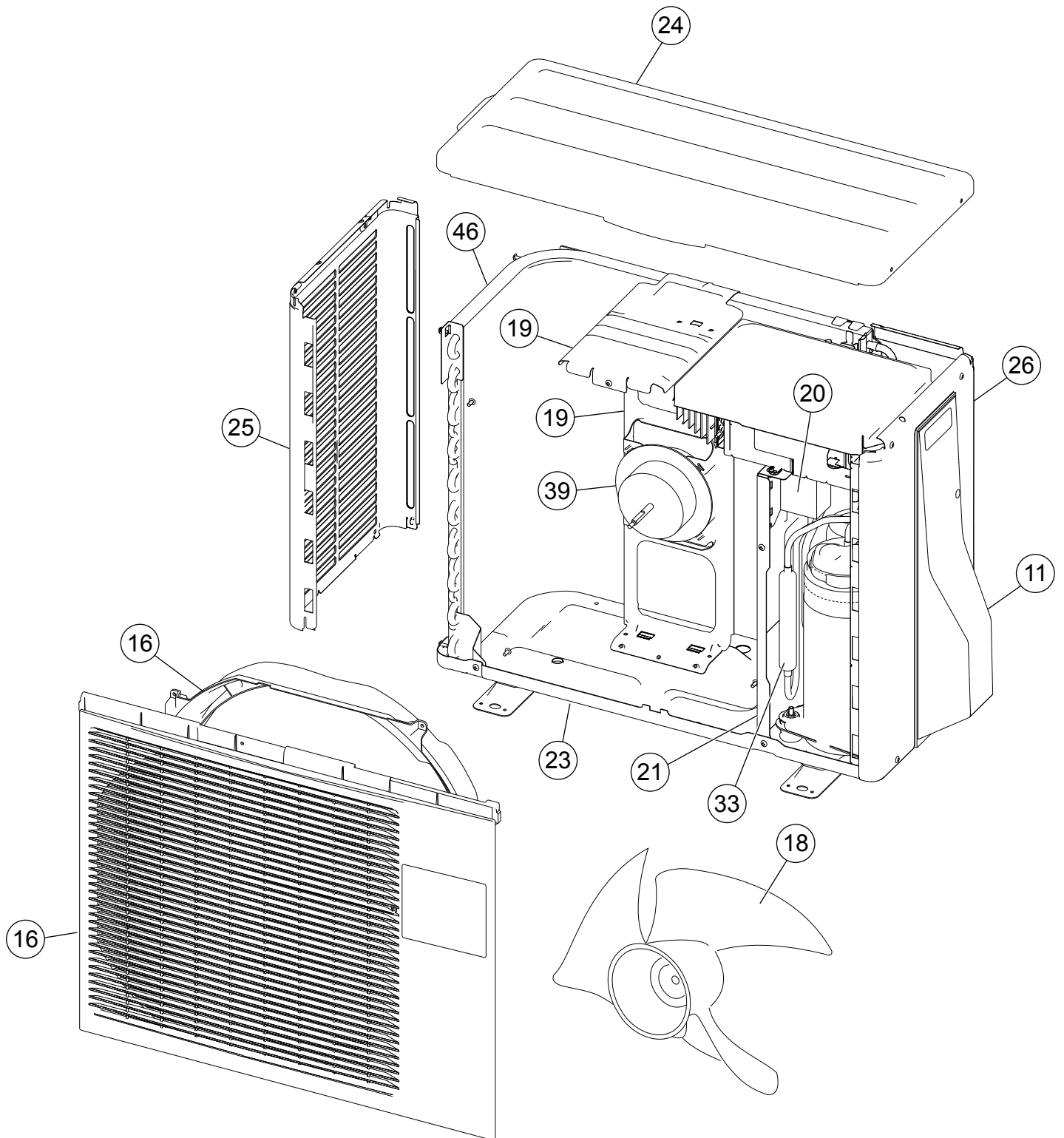

Model : AOHR07LCC, AOHR09LCC

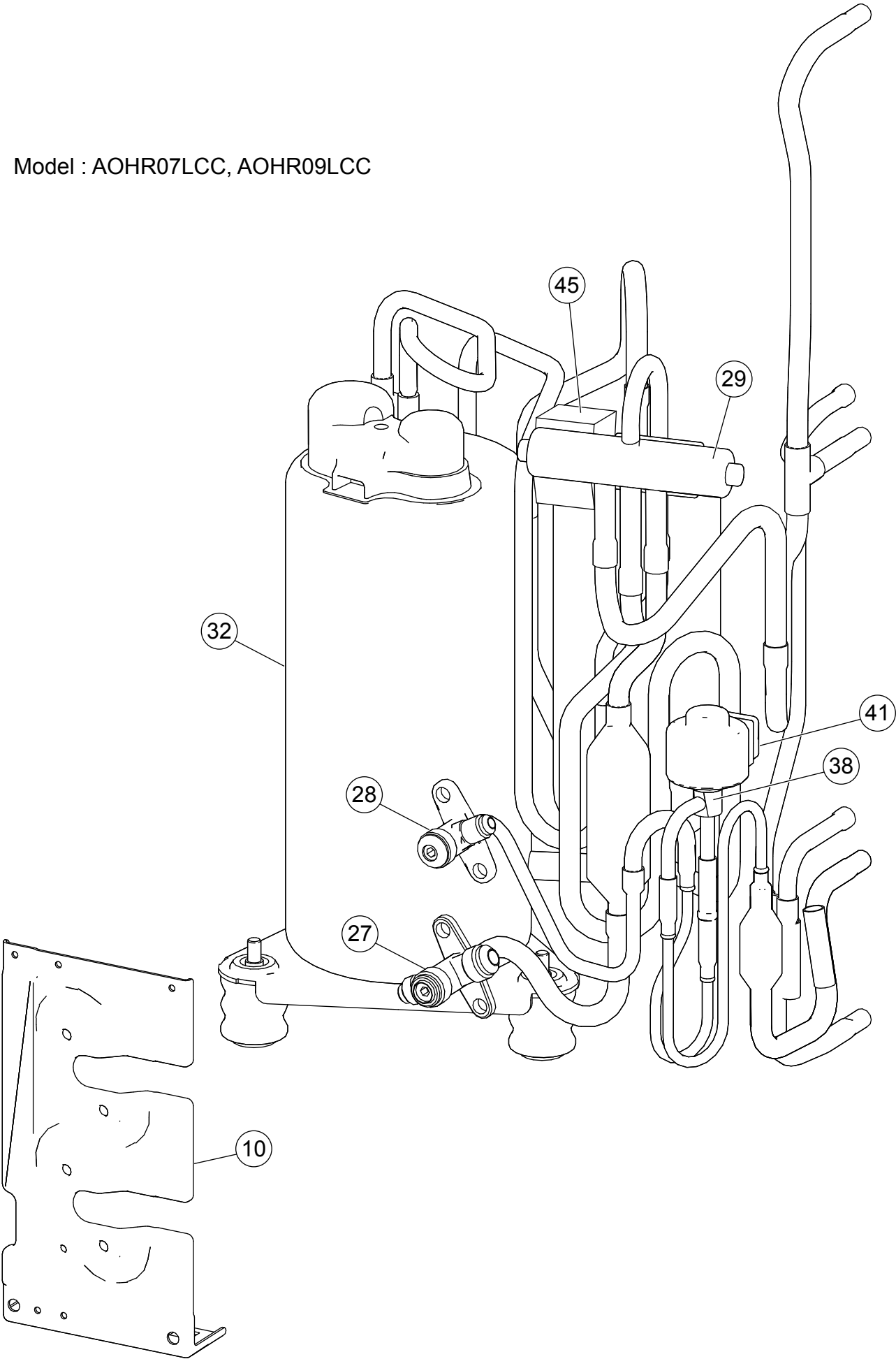

Model : AOHR07LCC, AOHR09LCC

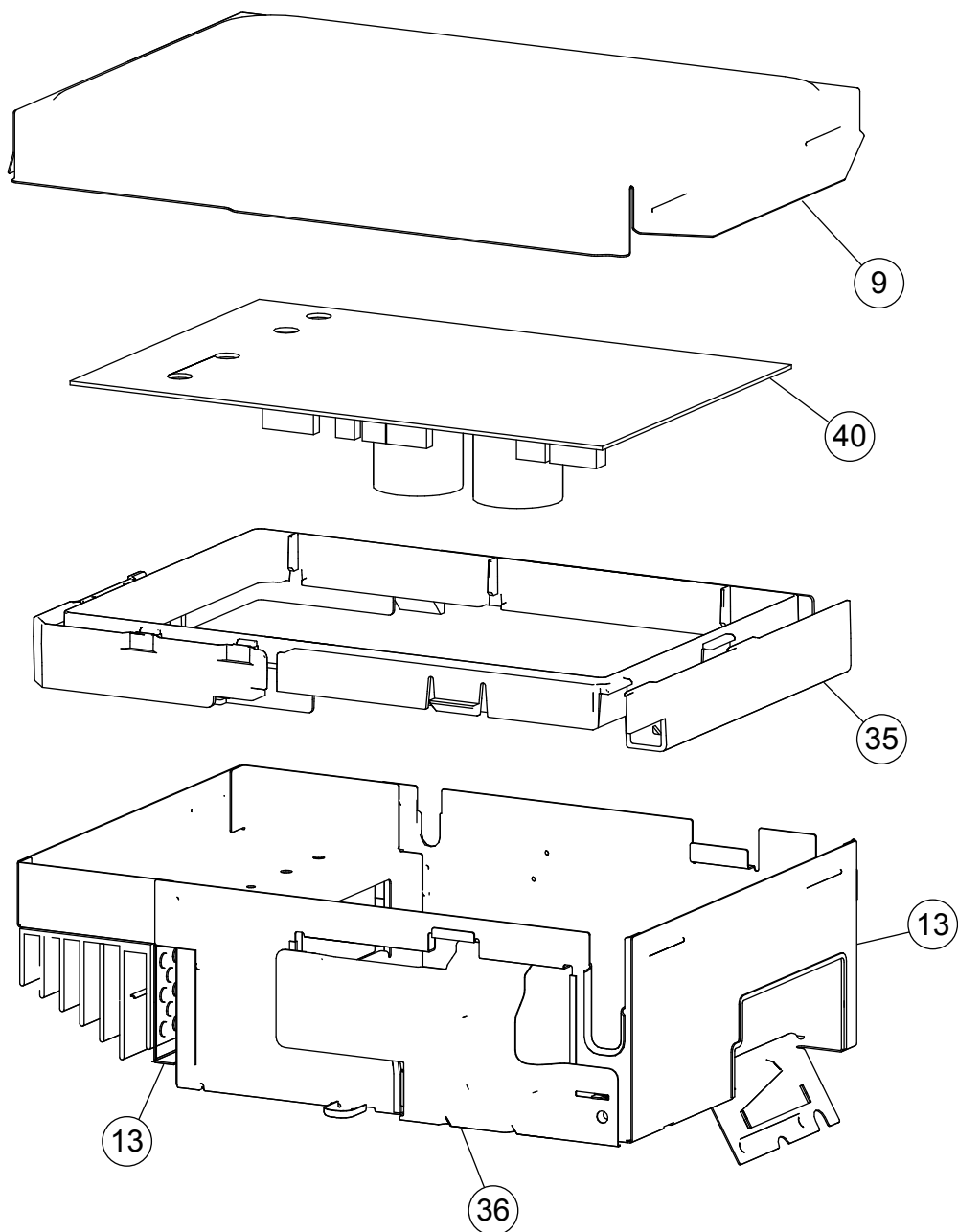

PARTS LIST





INDOOR UNIT

Ref. No.	Description	Part No.	Ord. Q'ty
		ASHA07LCC ASHA09LCC	
1	Air Filter	9309997011	
2	Filter (Electric)	9312153015	
3	Filter (ION)	9311925033	
4	Holder (Filter)	9306602017	
5	Clamper (Grille)	9306755010	
6	Front Panel Total Assy	9313130183	
7	Intake Grille Assy	9313131142	
20	Gear-A	9309994003	
21	Casing Assy	9311354079	
24	Crossflow Fan Assy	9307836015	
26	Clamp (Motor)	9310102008	
27	Shaft Holder-C Assy	9306628017	
28	Drain Hose Assy	9314147012	
29	Drain Cap Assy	9314493010	
30	Wire Clamper	9311946014	
31	Box (Switch)	9312908011	
32	Cover (Switch)	9312909018	
33	Evaporator Total Assy	9313099015	
36	Joint Pipe Assy	9313104016	
37	Insulation (Pipe)-E	9304607007	
38	Holder (Evaporator)-L	9309982017	
39	Holder (Evaporator)-R	9309983014	
40	Holder (Room Thermistor)	9310	
42	Air Seal	9310611005	
46	Step Motor	9900139025	
48	Fan Motor Assy	9601814016	
51	Remote Control Unit	9315027030	
52	Bracket Panel	9310001004	
53	Remote Control Unit Holder	9305642014	
61-1	Flow Control Panel-U	9309991033	
61-2	Flow Control Panel-Z	9309992030	
188	Power Cord Assy (Power Cord+Terminal)	9900339036	
236	Controller PCB Assy	9705656109 (K02DR-0503HSE-C1)	
---	Pipe Temperature Thermistor	9702039042	
---	Room Temperature Thermistor	9700801108	
---	Indicator PCB Assy	9705039032	

OUTDOOR UNIT

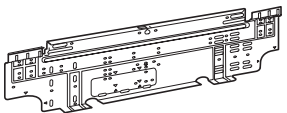
Ref. No.	Description	Part No.	Ord. Q'ty
		AOHR07LCC AOHR09LCC	
9	Cover (Case)	9331256018	
10	Bracket Valve	9310229026	
11	Cover (Switch)	9310979013	
13	Inverter Case Assy	9331279017	
16	Front Panel Assy	9331334013	
18	Propeller Fan	9309909014	
19	Bracket (Motor) Assy	9331355018	
20	Reactor Assy	9900357016	
21	Separator Assy	9331392013	
23	Base Assy	9331280013	
24	Top Panel Assy	9331332019	
25	Cabinet Left Assy	9313991036	
26	Cabinet Right Assy	9331336017	
27	3-Way Valve Assy	9331303019	
28	2-Way Valve Assy	9331301015	
29	4-Way Valve Assy	9331305013	
32	Compressor Assy	9315206015	
33	Muffler	9308660015	
35	PCB Holder	9331261012	
36	Cover (Inverter Case)	9331258012	
38	Pulse Motor Valve Assy	9331317016	
39	Motor	9602117017	
40	Inverter PCB Assy (07)	9707078039	
40	Inverter PCB Assy (09)	9707078015	
41	Expansion Valve Coil	9900057039	
45	Solenoid	9970055010	
46	Condenser Assy	9331291019	
---	Fuse Holder	0501454012	
---	Fuse	0600382018	
---	Thermister Holder Pipe	313714262805	
---	Thermistor Spring-A	313728262708	
---	Thermistor Spring	9300089012	
---	Terminal	9306489038	
---	Cord Clamp	9307271014	
---	Rubber Cushion	9312680016	
---	Nut Special Assy	9313452018	
---	Protective Net	9331262019	
---	Thermistor Assy	9900148034	
---	Thermistor (Outdoor Temp)	9900210038	
---	Emblem Rear	9315211019	

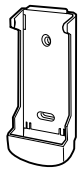
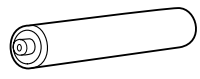
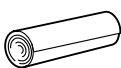
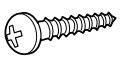
STANDARD ACCESSORIES

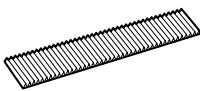
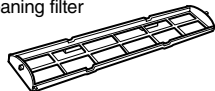
Name and Shape	Part No.
	ASHA07LCC ASHA09LCC
Wall hook bracket 	9312752027
Remote control unit 	9315027030
Remote control unit holder 	9305642045
Battery (penlight) 	0600185527
Cloth tape 	9310519004
Tapping screw (big) (φ 4 x 25) 	0700076046
Tapping screw (small) (φ 3 x 12) 	0700019036
Air cleaning filter 	9312153015
	9311925033
Air cleaning filter frame 	9306602017

0602G3038