



**SPLIT TYPE
ROOM AIR CONDITIONER
WALL MOUNTED type**

**SERVICE
MANUAL**

Models

Indoor unit	Outdoor unit
ASH9USCCW	AOH9USCC
ASH9USCCW	AOH9UFCC
ASH12USCCW	AOH12USCC



CONTENTS

SPECIFICATIONS	1
OUTLINE AND DIMENSIONS	2
REFRIGERANT SYSTEM DIAGRAM	4
CIRCUIT DIAGRAM	5
INDOOR PRINTED CIRCUIT BOARD CIRCUIT DIAGRAM ...	7
ERROR CONTENTS	8
DISASSEMBLY ILLUSTRATION	9
PARTS LIST	14
STANDARD ACCESSORIES	16

SPECIFICATIONS

TYPE		COOLING & HEATING		
INDOOR UNIT		ASH9USCCW		ASH12USCCW
OUTDOOR UNIT		AOH9USCC	AOH9UFCC	AOH12USCC
COOLING CAPACITY	(kW)	2.60	2.60	3.25
HEATING CAPACITY	(kW)	2.95	2.95	3.95

ELECTRICAL DATA

POWER SOURCE		230V 50Hz	230V 50Hz	230V 50Hz
RUNNING CURRENT	(A)			
	COOL	4.8	4.8	5.9
	HEAT	4.1	4.1	5.6
INPUT WATTS	(kW)			
	COOL	1.07	1.07	1.35
	HEAT	0.90	0.90	1.28
E.E.R.	(kW/kW)			
	COOL	2.43	2.43	2.41
	HEAT	3.28	3.28	3.09
MOISTURE REMOVAL	(ℓ/h)	1.3	1.3	1.8
AIR CIRCULATION-Hi	(m ³ /hr)	COOL 540 HEAT 515	COOL 540 HEAT 515	COOL 535 HEAT 545

COMPRESSOR

TYPE		Hermetic type, Permant split condenser, 2 pole, Single phase, Induction motor, Rotary		
DISCRIMINATION		802-141-45B	PA118X1C-4DZ	802-361-35B
POWER SOURCE		220, 230, 240V / 50Hz	220, 230, 240V / 50Hz	220, 230, 240V / 50Hz
REFRIGERANT	R410A (g)	650	650	750
REFRIGERANT CHARGE	Pipe length			
	7.5 m	650	650	750
	10 m	700	700	800
	(g)	800	800	900
ADDITIONAL REFRIGERANT	(g / m)	20	20	20

FAN MOTOR

POWER SUPPLY		(V)	230	230	230
INDOOR UNIT	(r.p.m.)				
	HI-SPEED	COOL 1310 HEAT 1250	COOL 1310 HEAT 1250	COOL 1310 HEAT 1330	
	MED-SPEED	COOL 1170 HEAT 1140	COOL 1170 HEAT 1140	COOL 1200 HEAT 1210	
	LO-SPEED	COOL 1030 HEAT 1020	COOL 1030 HEAT 1020	COOL 1090 HEAT 1090	
	QUIET	COOL 900 HEAT 900	COOL 900 HEAT 900	COOL 980 HEAT 980	
OUTDOOR UNIT	(r.p.m.)	800	800	770	

DIMENSIONS

INDOOR UNIT	H x W x D	(mm)	257 x 808 x 187	257 x 808 x 187	257 x 808 x 187
OUTDOOR UNIT	H x W x D	(mm)	535 x 650 x 250	535 x 650 x 250	535 x 695 x 250

WEIGHT

INDOOR UNIT	GROSS / NET	(kg)	10 / 8	10 / 8	10 / 8
OUTDOOR UNIT	GROSS / NET	(kg)	29 / 26	29 / 26	34 / 31

NOISE LEVEL

INDOOR UNIT	(dB)			
	HI-SPEED	COOL 40 HEAT 38	COOL 40 HEAT 38	COOL 40 HEAT 40
	MED-SPEED	COOL 38 HEAT 36	COOL 38 HEAT 36	COOL 38 HEAT 38
	LO-SPEED	COOL 35 HEAT 34	COOL 35 HEAT 34	COOL 36 HEAT 35
	SUPER QUIET	COOL 30 HEAT 28	COOL 30 HEAT 28	COOL 33 HEAT 32
OUTDOOR UNIT	(dB)	COOL 46 HEAT 46	COOL 46 HEAT 46	COOL 48 HEAT 48

DIMENSIONS

INDOOR UNIT

Unit : mm

Models : ASH9USCCW
ASH12USCCW

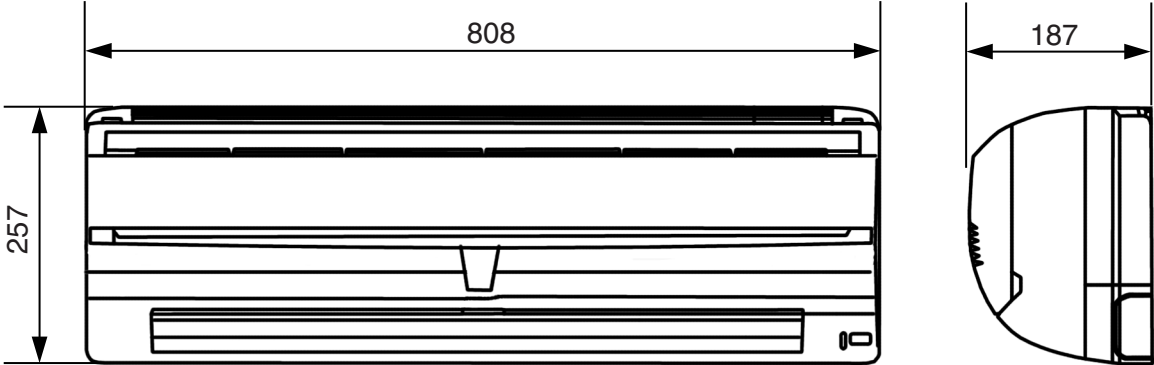

OUTDOOR UNIT

Model : AOY9USCC
AOY9UFCC

Unit : mm

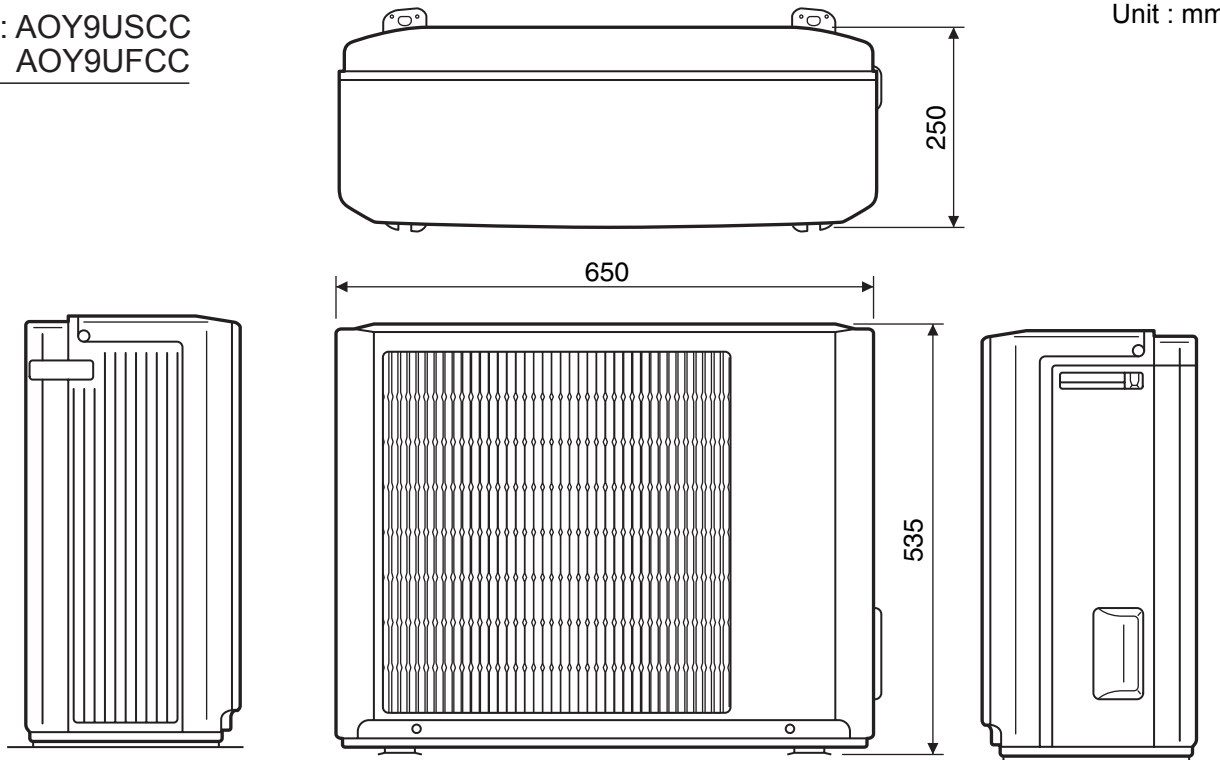

Model : AOY12USCC

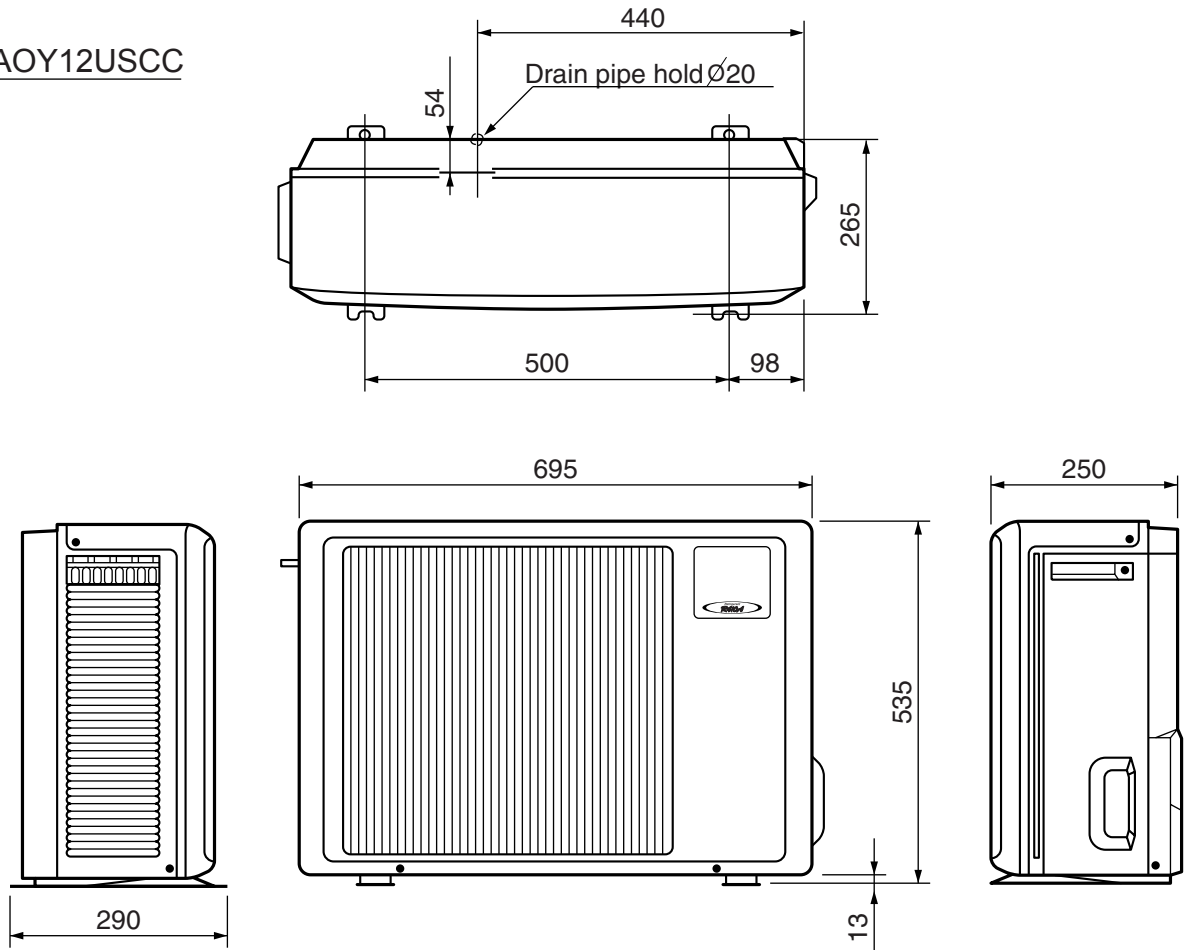

REFRIGERANT SYSTEM DIAGRAM

**Models : ASY9USCCW / AOY9USCC
ASY9USCCW / AOY9UFCC**

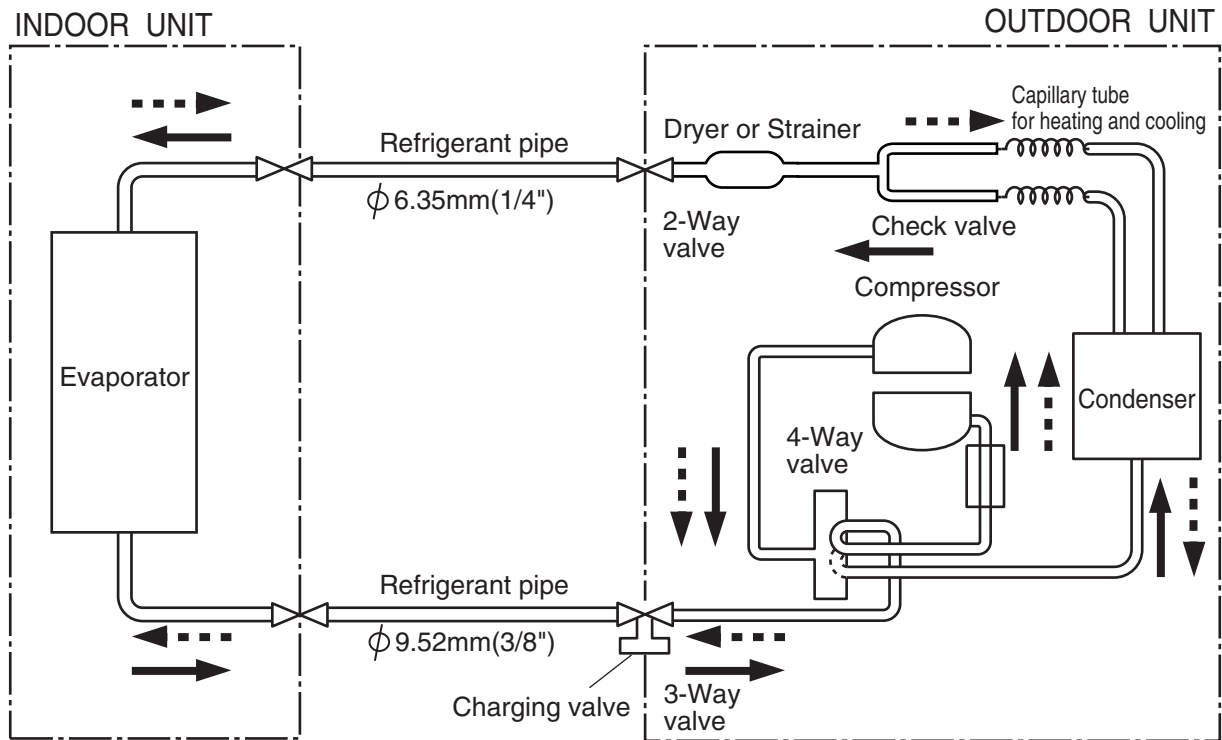

Models : ASY12USCCW / AOY12USCC

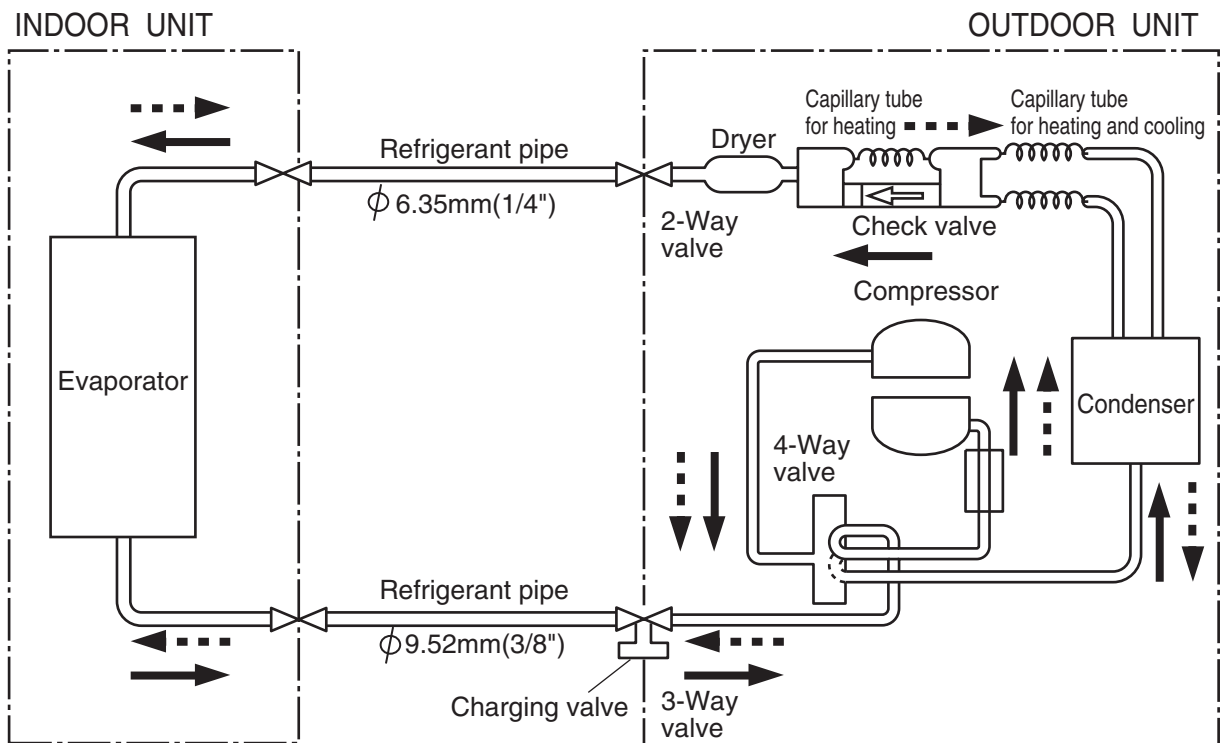

- Cooling
- Heating
- : Flare coupling

CIRCUIT DIAGRAM

Models : ASY9USCCW
ASY12USCCW

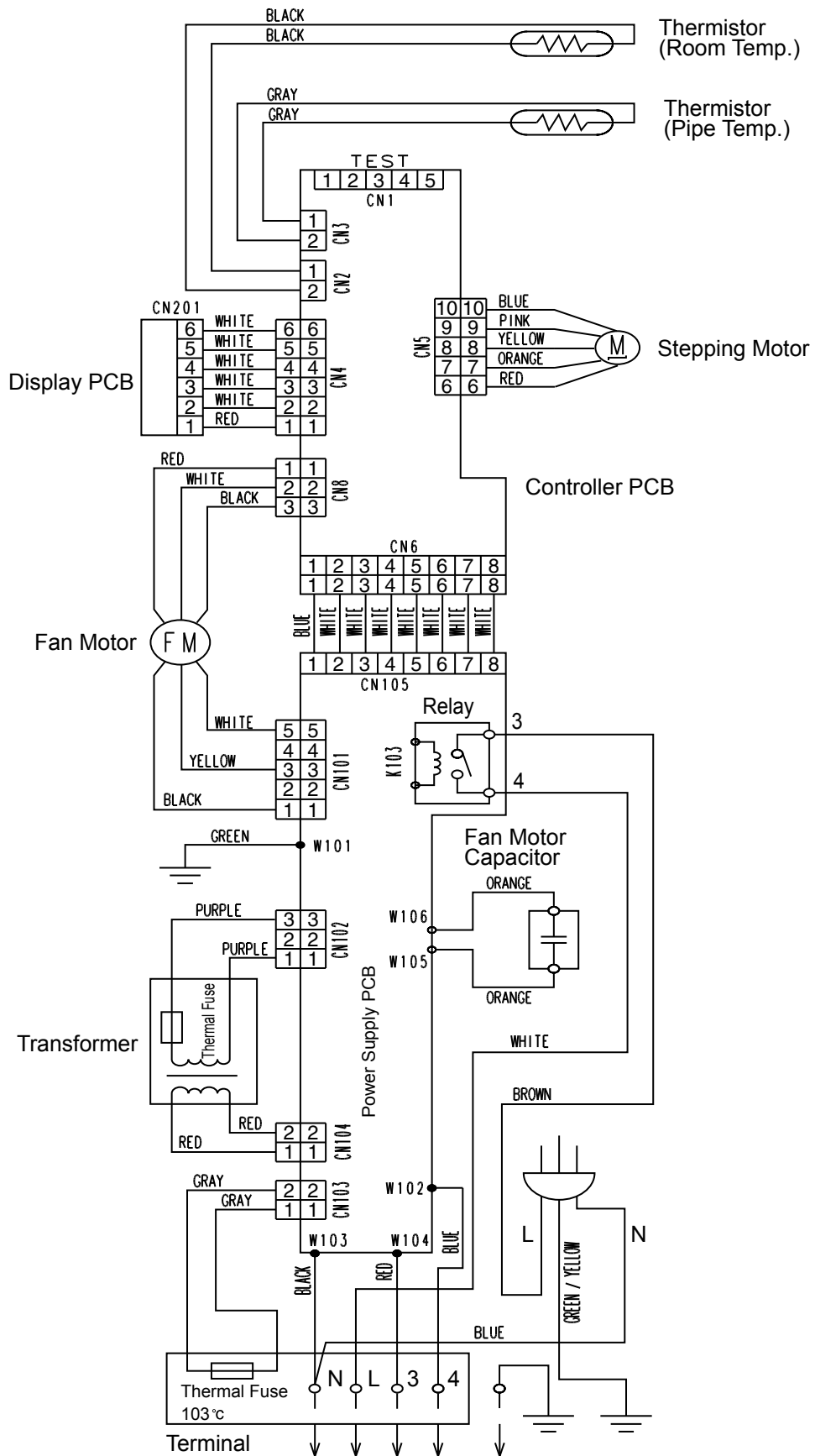

**Models : AOY9USCC
AOY12USCC**

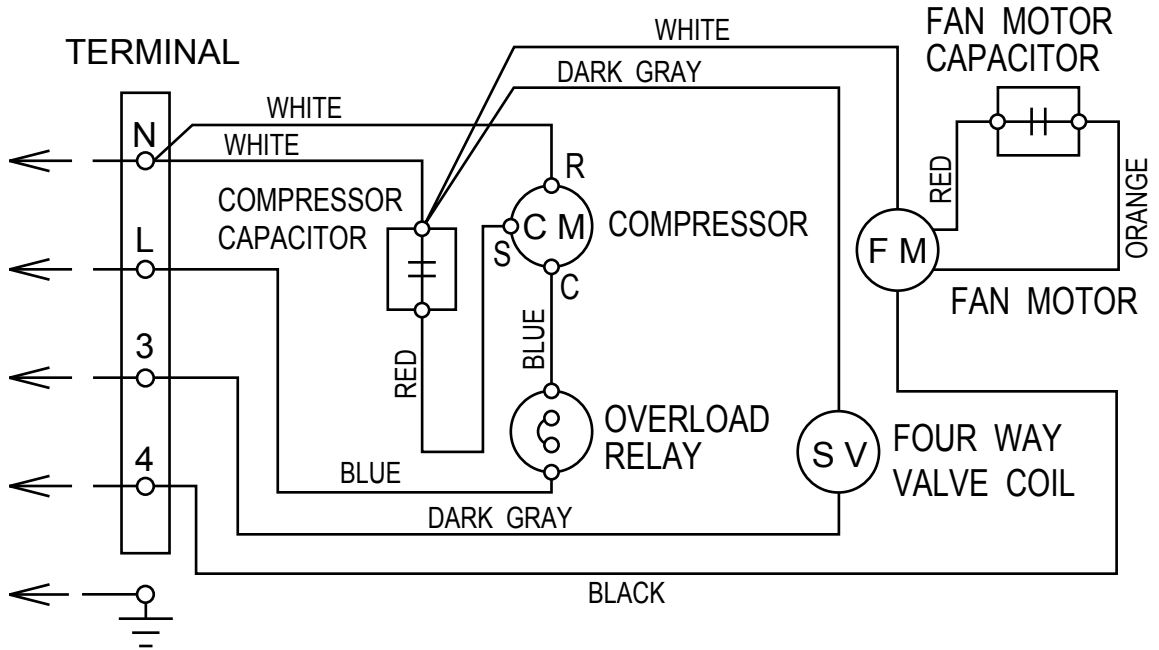

Model : AOY9UFCC

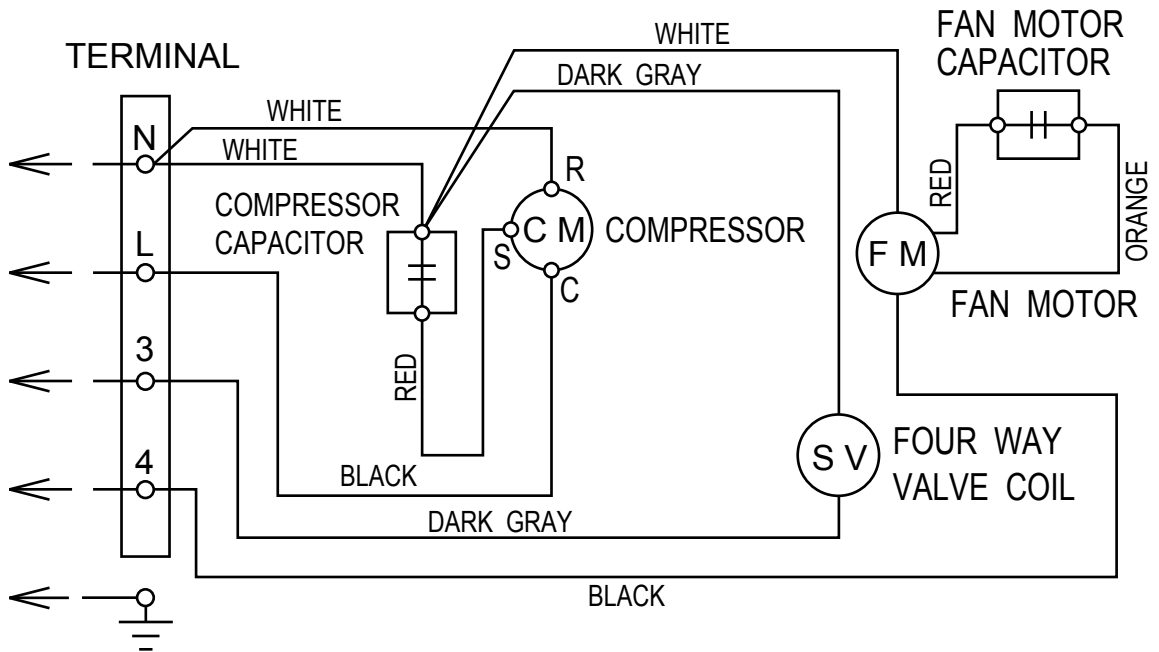

INDOOR PCB CIRCUIT DIAGRAM

Jumper wire configurations

Switch	Function	ON/Linked	OFF/Open
JP1	Heating compensation	+4	+2
JP2	Cooling compensation	0	-2
JP3	Auto restart	enable	disable
JP4	Custom code	A	B

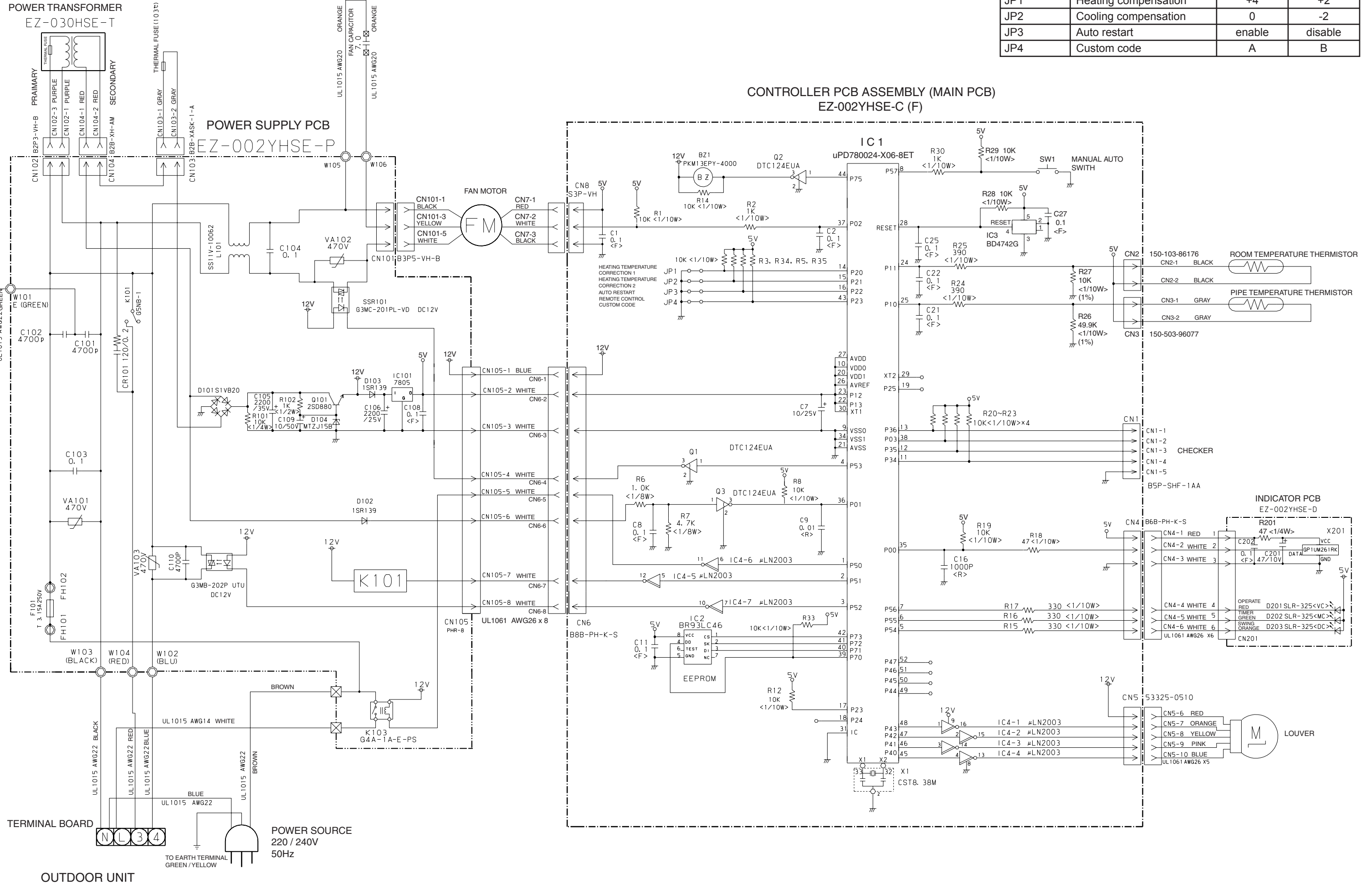

ERROR DISPLAY

Large division indication			Small division indication		
LED flashing		Error contents	LED flashing		Error contents
operation	timer		operation	timer	
0.5 second 2 times	0.1 second	thermistor	0.1 second	0.5 second 2 times	room temp. thermistor error
			0.1 second	0.5 second 3 times	heat exchanger thermistor error
0.5 second 4 times	0.1 second	control unit (indoor unit)	0.1 second	0.5 second 2 times	MANUAL AUTO button error
			0.1 second	0.5 second 4 times	power source Hz decision error
0.5 second 6 times	0.1 second	fan motor (indoor unit)	0.1 second	0.5 second 2 times	lock error
			0.1 second	0.5 second 3 times	r.p.m. error
0.1 second	0.1 second				model distinction error

Indication :

When an error happens, first indication is "Large division indication".

Indication is switched by pushing TEST OPERATION button between "Large" and "Small".

DISASSEMBLY ILLUSTRATION

Models : ASH9USCCW
ASH12USCCW

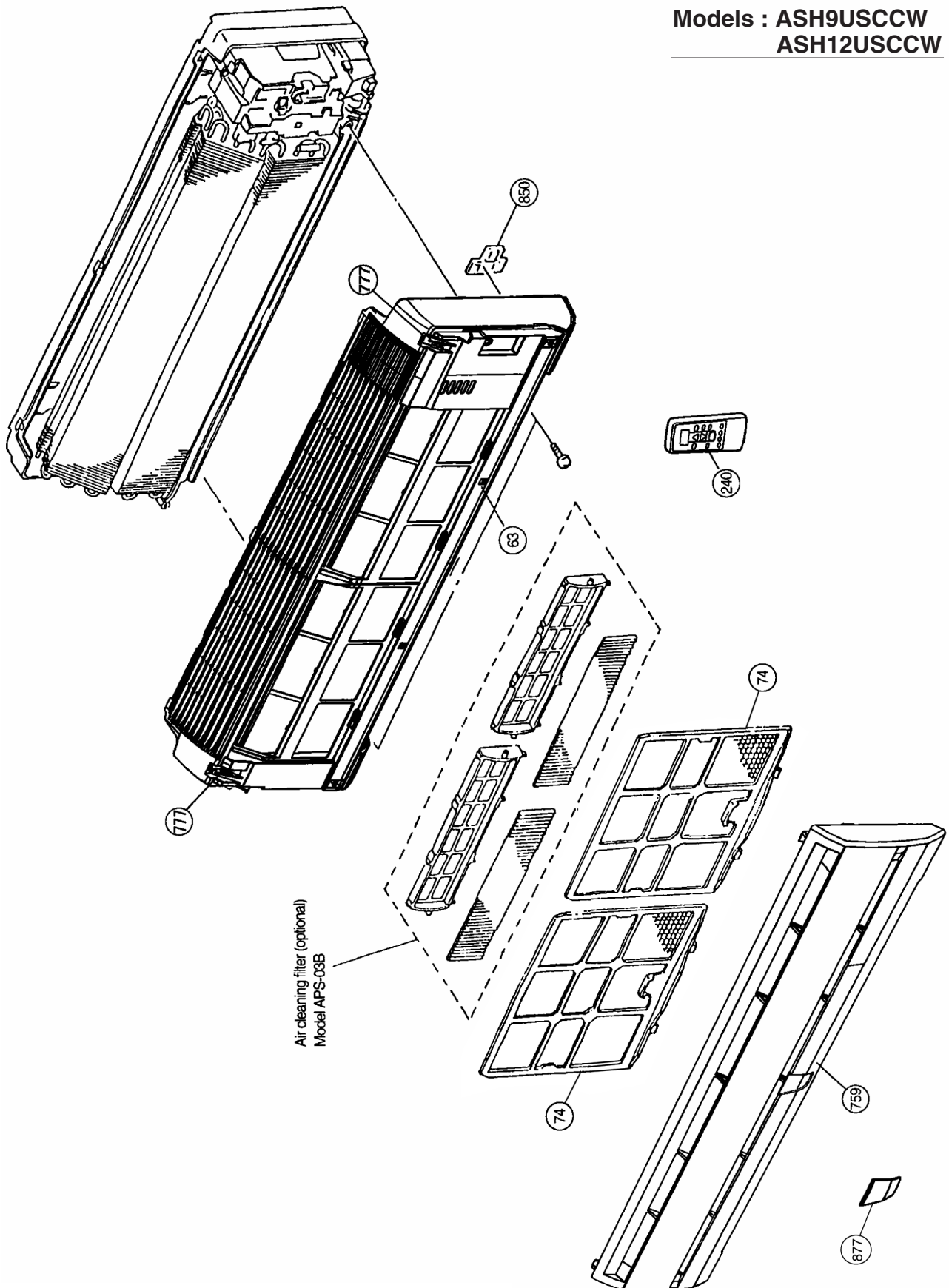

Models : ASY9USCCW
ASY12USCCW

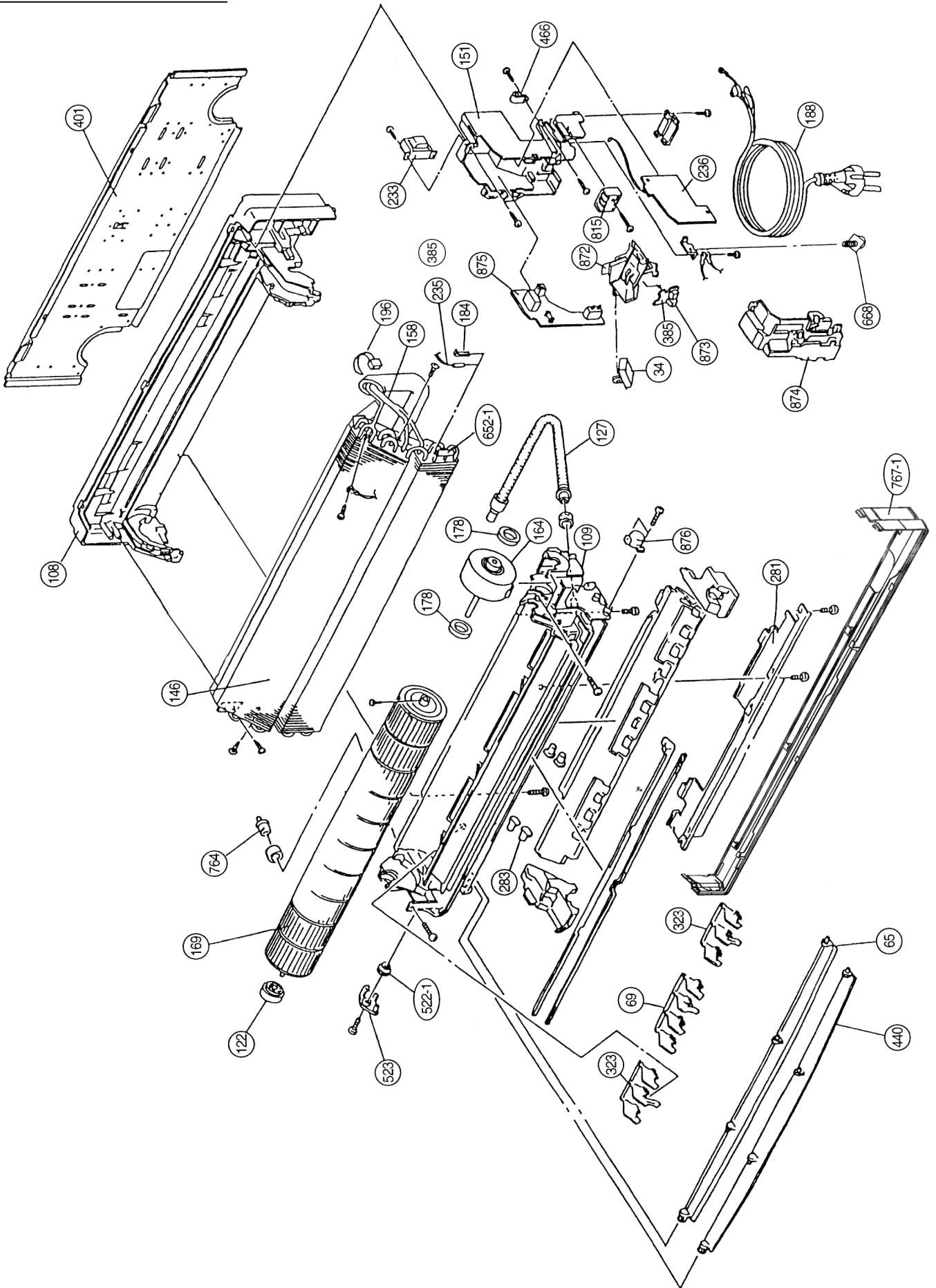

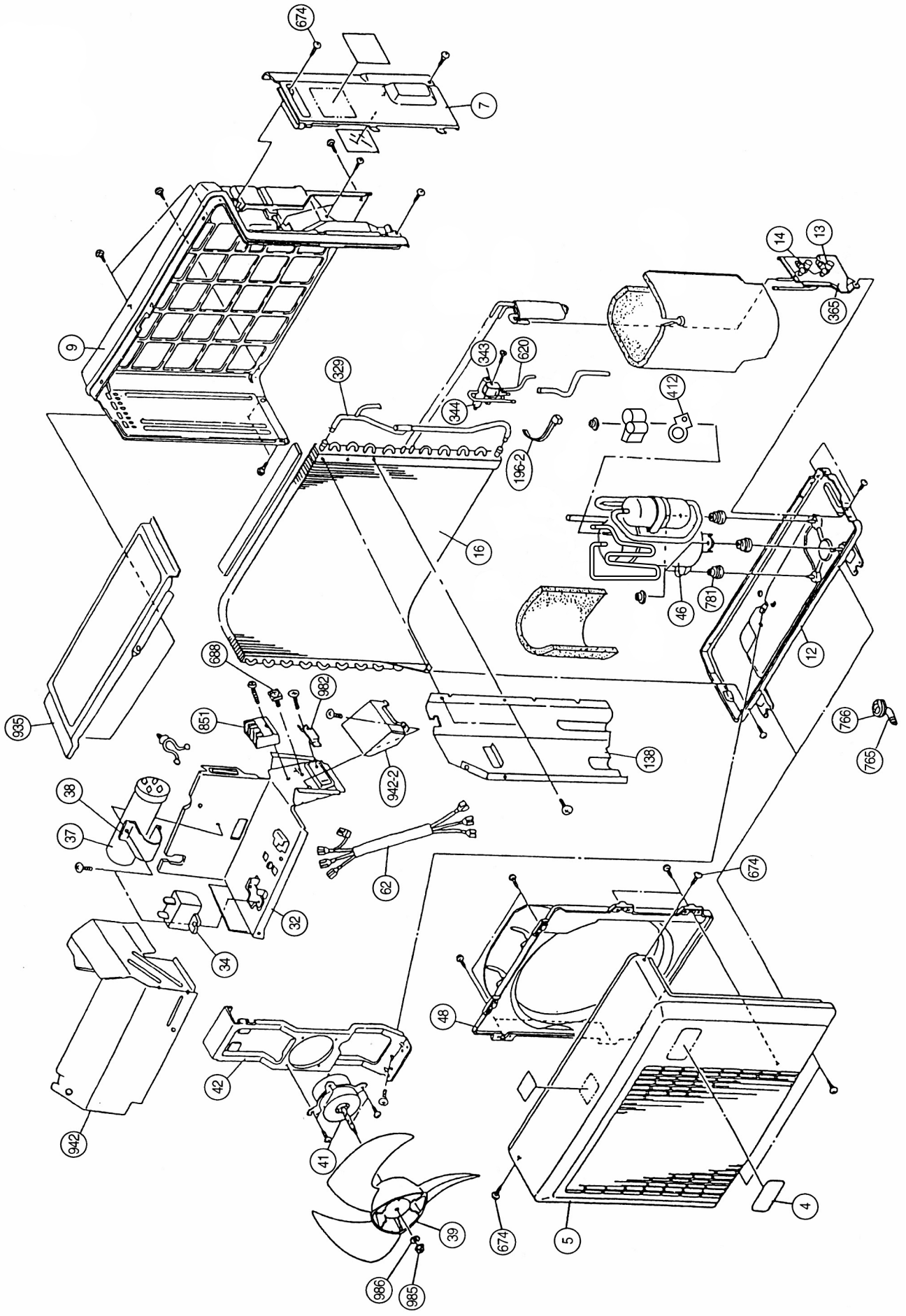

Model : AOY12USCC

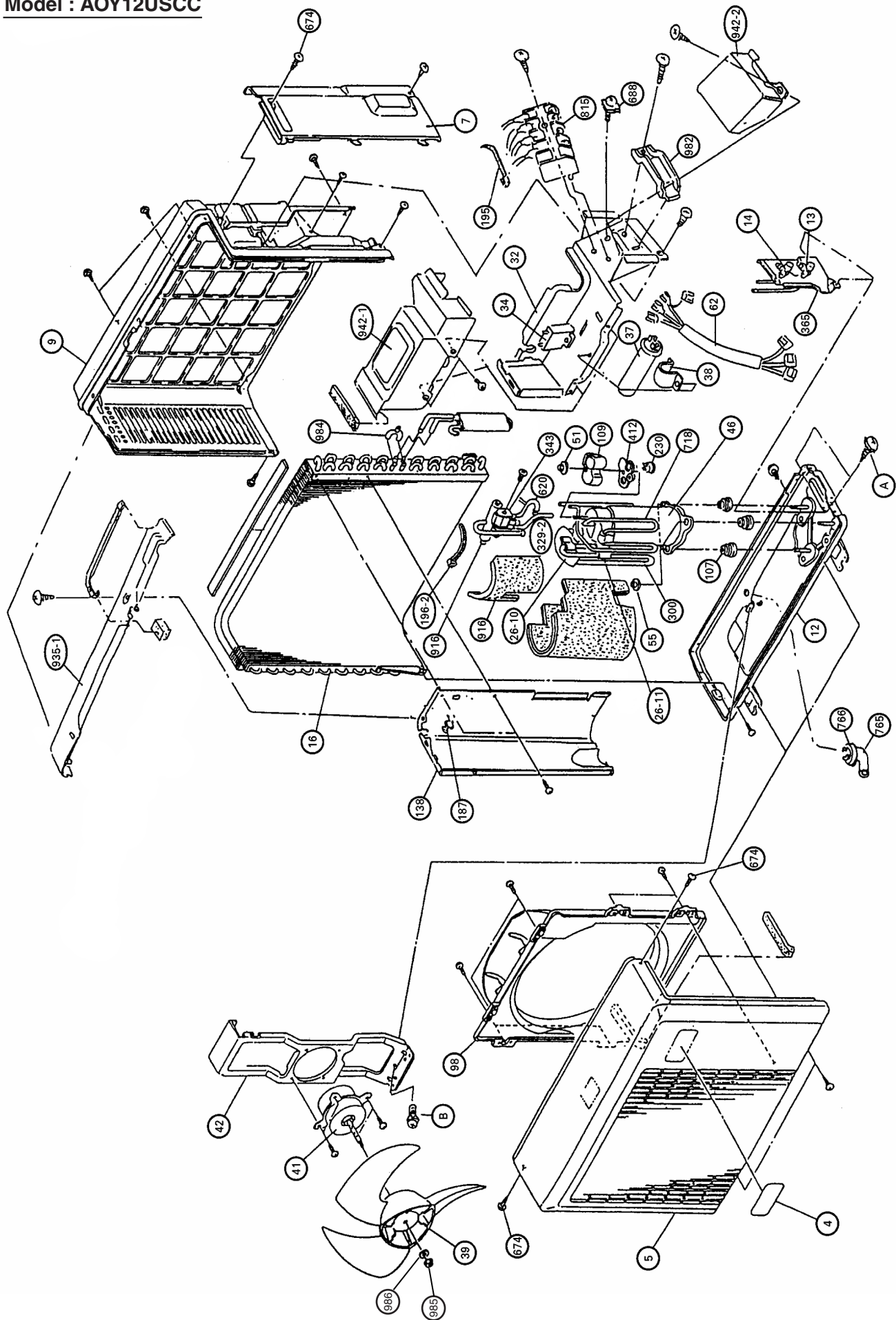

PARTS LIST

INDOOR UNIT







Ref. No.	Description	Part No.		Ord. Q'ty
		ASH9USCCW	ASH12USCCW	
34	Capacitor (Fan Motor)	9900089061	9900089061	
63	Panel (Front) Total Assy	9312172085	9312172115	
65	Flow Control Panel-Z	9306058012	9306058012	
69	Louver-A	9306055028	9306055028	
74	Filter	9305444014	9305444014	
108	Base	9309755062	9309755062	
109	Casing	9306052027	9306052027	
122	Shaft Holder -B	9303066010	9303066010	
127	Drain Hose Assy	9305550029	9305550029	
146	Evaporator Assy	9330144019	9330144019	
151	Control Box	9330007017	9330007017	
158	Connecting Pipe Assy	9306416010	9306416010	
164	Fan Motor Assy-IN	9601171010	9601171010	
169	Cross-Flow Fan Assy	9307836015	9307836015	
178	Motor Cushion -M	9601302018	9601302018	
184	Thermistor Sping	313728262708	313728262708	
188	Power Cord Assy	9702595043	9702595043	
196	Clamp SKB-150	313035356905	313035356905	
233	Power Transformer	9900028015	9900028015	
235	Thermistor Assy -Pipe	9702039059	9702039059	
236	Controller PCB Assy	9704865038	9704865014	
240	Remote Control Unit	9312058020	9312058020	
281	Clamp Metal (Pipe)	9306063009	9306063009	
283	Bushing-A	9303529010	9303529010	
323	Louver-B	9306056025	9306056025	
385	PCB (Power and Indicator)	9704870018	9704870018	
401	Wall Hook Bracket	9304358008	9304358008	
440	Flow Control Panel-U	9306057015	9306057015	
466	Clamp NK-4N	313714328805	313714328805	
522-1	Gear-A	9306062002	9306062002	
523	Gear Bracket	9306407001	9306407001	
652-1	Thermistor Holder Pipe	313714262805	313714262805	
668	Screw w/Washer	313681304205	313681304205	
759	Intake Grill -A	9330002012	9330002012	
764	Drain Cap Assy	9304150008	9304150008	
767-1	Bottom Cover -A	9330004016	9330004016	
777	Clamper (Grille)	9306755010	9306755010	
815	Terminal	9900040048	9900040048	
850	Window (Receiver	9330003019	9330003019	
872	Indicator Case	9330009011	9330009011	
873	Lamp Cover	9330014015	9330014015	
874	Control Box Cover	9330008014	9330008014	
876	Step Motor	9900139018	9900139018	
877	Face Panel (Front)-A	9330005044	9330005044	

OUTDOOR UNIT

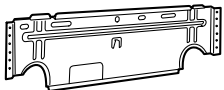
Ref. No.	Description	Part No.		Ord. Q'ty
		AOH9USCC	AOH9UFCC	
4	Emblem-Rear	9308474018	9308474018	
5	Cabinet Front Panel, Plastic	9306016012	9306016012	
7	Connector Cover	9306018016	9306018016	
9	Cabinet Rear Panel, Plastic	9306017019	9306017019	
12	Base Assy, Painted	9304806042	9304806042	
13	3-Way Valve	9312863013	9312863013	
14	2-Way Valve	9312862016	9312862016	
16	Condenser Assy	9309104020	9309104020	
32	Control Box Metal	9306475024	9306475024	
34	Capacitor (Fan Motor)	9900089023	9900089023	
37	Capacitor (Running)	9307588068	9307588013	
38	Clamp Metal (Capacitor)	313468061808	313468061808	
39	Propeller Fan	9306565015	9306565015	
41	Fan Motor Assy-Out	9307095016	9307095016	
42	Bracket (Motor)	9306021016	9306021016	
46	Compressor Assy	9311012016	9314429019	
48	Fan Ring	9306019020	9306019020	
62	Wire Assy (Shield)-A	9305791026	9305695027	
138	Separate Wall Metal	9306474003	9306474003	
195	Clamp SKB-100	313361275805	313361275805	
196-2	Clamp SKB-3MC	9305335008	9305335008	
230	Overload Relay	9311143000	----	
343	Solenoid Coil	9970003011	9970003011	
344	4-Way Valve	9900162016	9900162016	
365	Bracket (Valve)	9306020026	9306020026	
412	Terminal Gasket (For Comp.)	9351505011	9314432002	
674	Screw, SUS410T +5014	9305848010	9305848010	
688	Screw w/Washer	313681304205	313681304205	
765	Drain Pipe (L-type)	9301102000	9301102000	
766	Drain Pipe Packing	9301143003	9301143003	
781	Rubber Cushion	9312680016	9312680016	
815	Terminal-4P	9306488017	9306488017	
935	Reinforcement Plate	9306473006	9306473006	
942	Control Box Cover Metal	9306476007	9306476007	
942-2	Control Box Cover-B Metal	9305975006	9305975006	
982	Cord Clamp, Plastic	9302271002	9302271002	
985	Special Nut w/Washer	9304902003	9304902003	
986	Special Washer	9304903000	9304903000	
A	Screw (with Inner Washer)	9357297002	9357297002	
----	BR Sheet 180x180x T2	9305039067	9305039067	

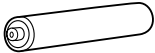
Ref. No.	Description	Part No.	Ord. Q'ty
		AOH12USCC	
4	Emblem-Rear	9308474018	
5	Cabinet Front Panel, Plastic	9306386016	
7	Connector Cover	9306119010	
9	Cabinet Rear Panel, Plastic	9306385019	
12	Base Assy, Painted	9306118020	
13	3-Way Valve	9312865017	
14	2-Way Valve	9312864010	
16	Condenser Assy	9308459039	
32	Control Box Metal	9308561022	
34	Capacitor (Fan Motor)	9900089030	
37	Capacitor (Running)	9307588013	
38	Clamp Metal (Capacitor)	313468061808	
39	Propeller Fan	9305538003	
41	Fan Motor Assy-Out	9307715020	
42	Bracket (Motor)	9305536016	
46	Compressor Assy	9311133018	
51	Special Nut M5	9307091001	
55	Special Nut M6	313252257701	
98	Fan Ring	9305581023	
109	Terminal Cover	9307090004	
138	Separate Wall Metal	9305971008	
187	Clamp No.1219	313361271706	
195	Clamp SKB-100	313361275805	
196	Clamp SKB-150	313035356905	
196-2	Clamp SKB-3MC	9305335008	
230	Overload Relay	9312899005	
343	Solenoid Coil	9970003011	
344	4-Way Valve	9900162016	
365	Bracket (Valve)	9306748012	
412	Terminal Gasket (For Comp.)	9351121006	
674	Screw, SUS410T +5014	9305848010	
688	Screw w/Washer	313681304205	
765	Drain Pipe (L-type)	9301102000	
766	Drain Pipe Packing	9301143003	
815	Terminal-4P	9306488017	
916	Noise Insulation -A	9306362003	
935-1	Reinforcement(Cabinet TOP)	9305973002	
935-2	Reinforcement -F (Cabinet Top)	9306123000	
942-1	Control Box Cover-A Metal	9308562012	
942-2	Control Box Cover-B Metal	9305975006	
946	Inlet Pipe	9306401009	
982	Cord Clamp, Plastic	9302271002	
A	Screw (with Inner Washer)	9357297002	
B	Screw (with Spring Washer)	0700179013	
----	BR Sheet 60x100x T5	9305039012	
----	BR Sheet 40x80x T5	9305039043	
----	BR Sheet 180x180x T2	9305039067	

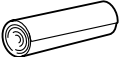
STANDARD ACCESSORIES

Name and Shape	Part No.
Wall hook bracket 	9304358008
Remote control unit 	9312058020
Battery (penlight) 	0600185534
Tapping screw (Ø4 x 25) 	0700076046
Cloth tape 	9308117007
Drain pipe (Including drain packing) 	9303029015



0309G2373