



# SPLIT TYPE ROOM AIR CONDITIONER

**WALL MOUNTED** type

# SERVICE MANUAL

Models	Indoor unit	Outdoor unit
	ASH9USBCW	AOH9UGBC
	ASH12USBCW	AOH12UGBC



## C O N T E N T S

SPECIFICATIONS .....	1
OUTLINE AND DIMENSIONS .....	3
REFRIGERANT SYSTEM DIAGRAM .....	5
CIRCUIT DIAGRAM .....	6
DISASSEMBLY ILLUSTRATION .....	7
PARTS LIST .....	11
STANDARD ACCESSORIES .....	14

## SPECIFICATIONS

TYPE		COOLING & HEATING	COOLING & HEATING
INDOOR UNIT		ASH9USBCW	ASH12USBCW
OUTDOOR UNIT		AOH9UGBC	AOH12UGBC
COOLING CAPACITY	(kW)	2.90	3.70
HEATING CAPACITY	(kW)	3.05	4.00

### ELECTRICAL DATA

POWER SOURCE		230V 50Hz	230V 50Hz
RUNNING CURRENT (A)	COOL	3.7	5.0
	HEAT	3.3	4.6
INPUT WATTS (kW)	COOL	0.84	1.13
	HEAT	0.75	1.04
E.E.R (kW/kW)	COOL	3.45	3.27
	HEAT	4.07	3.85
MOISTURE REMOVAL	(ℓ/hr)	1.3	1.9
AIR CIRCULATION-Hi	(m3/hr)	COOL 600 HEAT 600	COOL 700 HEAT 675

### COMPRESSOR

TYPE	Hermetic type, Permanent split condenser, 2 pole, Single phase, Induction motor		
CODE	GK113PAC	220, 230, 240V / 50Hz	GK151PAB 220-240V / 50Hz
REFRIGERANT R410A	(g)	900	970

### FAN MOTOR

POWER SUPPLY	(V)	230	230
INDOOR UNIT (r.p.m)	Hi-SPEED	COOL 1250 HEAT 1250	COOL 1450 HEAT 1400
	MED-SPEED	COOL 1100 HEAT 1120	COOL 1250 HEAT 1230
	LO-SPEED	COOL 950 HEAT 990	COOL 1050 HEAT 1060
	S-LO	COOL 800 HEAT 860	COOL 850 HEAT 900
OUTDOOR UNIT	(r.p.m)	730	820

### DIMENSIONS

INDOOR UNIT	H x W x D	275 x 790 x 215	275 x 790 x 215
OUTDOOR UNIT	(mm)	535 x 695 x 250	535 x 780 x 250

### WEIGHT

INDOOR UNIT	GROSS /	12 / 9	12 / 9
OUTDOOR UNIT	NET(kg)	33 / 30	37 / 35

### NOISE LEVEL

INDOOR UNIT (dB)	Hi-SPEED	COOL 40 HEAT 39	COOL 45 HEAT 43
	MED-SPEED	COOL 36 HEAT 35	COOL 41 HEAT 39
	LO-SPEED	COOL 32 HEAT 31	COOL 35 HEAT 34
	S-LO	COOL 27 HEAT 26	COOL 29 HEAT 28
OUTDOOR UNIT	(dB)	COOL 45 HEAT 46	COOL 48 HEAT 49

ADDITIONAL CHARGE OF REFRIGERANT (R410A)  
(ASH9USBCW / AOH9UGBC)  
(ASH12USBCW / AOH12UGBC)

Refrigerant suitable for a piping length of 7.5 m is charged in the outdoor unit at the factory.  
When the piping is longer than 7.5 m, additional charging is necessary.  
For the additional amount, see the table below.

PIPE LENGTH	7.5 m	10 m	15 m
ADDITIONAL REFRIGERANT	None	50 g	150 g

Between 7.5 m and 15 m, when using a connection pipe other than that in the table,  
charge additional refrigerant with 20g /1 m as the criteria.  
(The maximum length of piping is 15m. If the units are further apart than this, correct  
operation can not be guaranteed.)

# D I M E N S I O N S

## INDOOR UNIT

(ASH9USBCW / ASH12USBCW)

Unit : mm

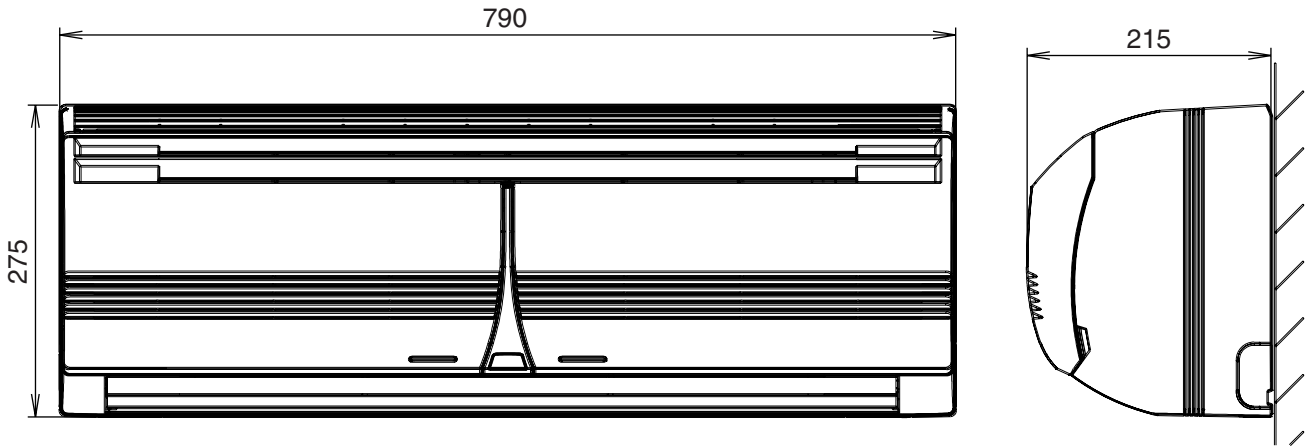

## OUTDOOR UNIT

(AOH9UGBC)

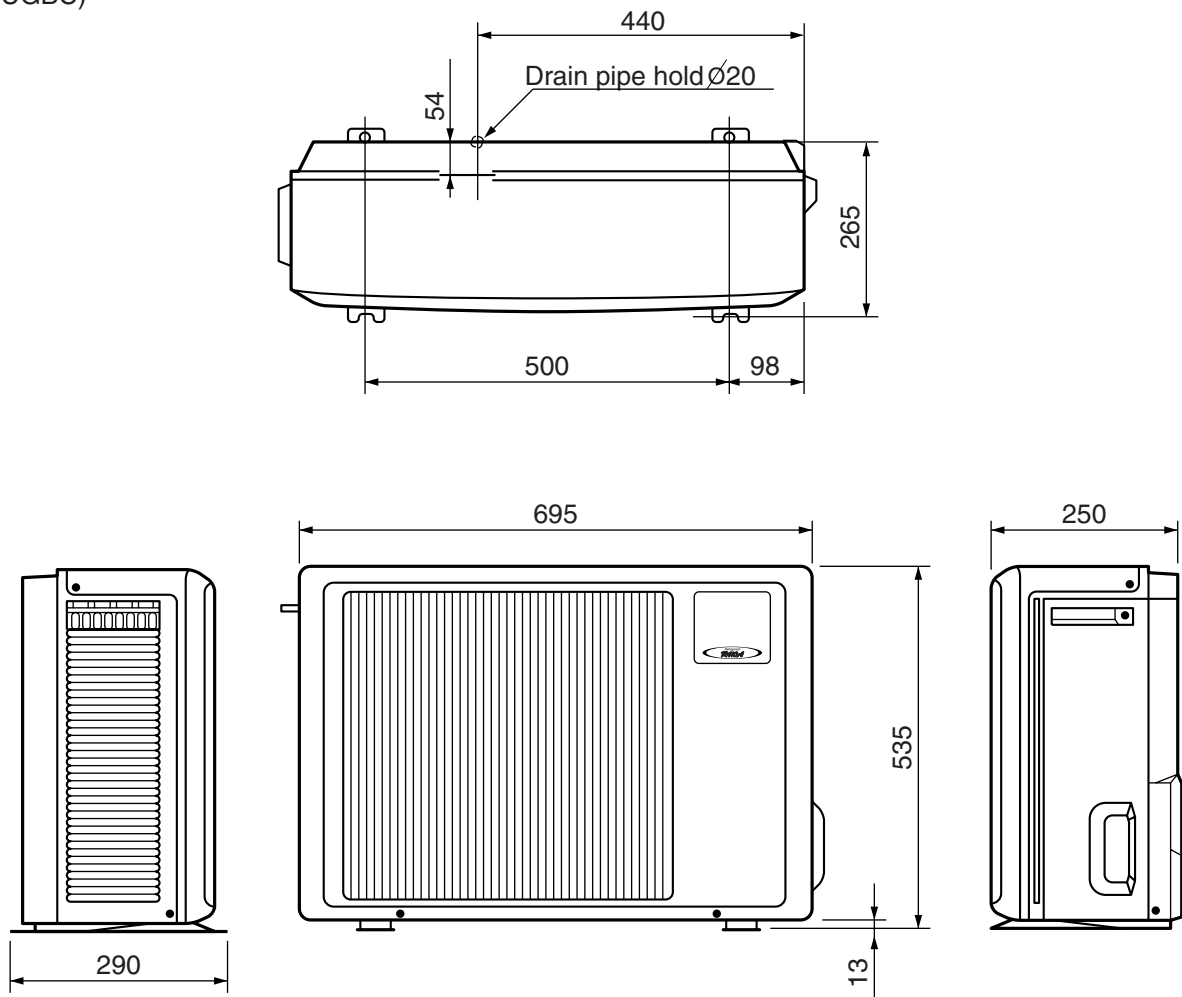

(AOH12UGBC)

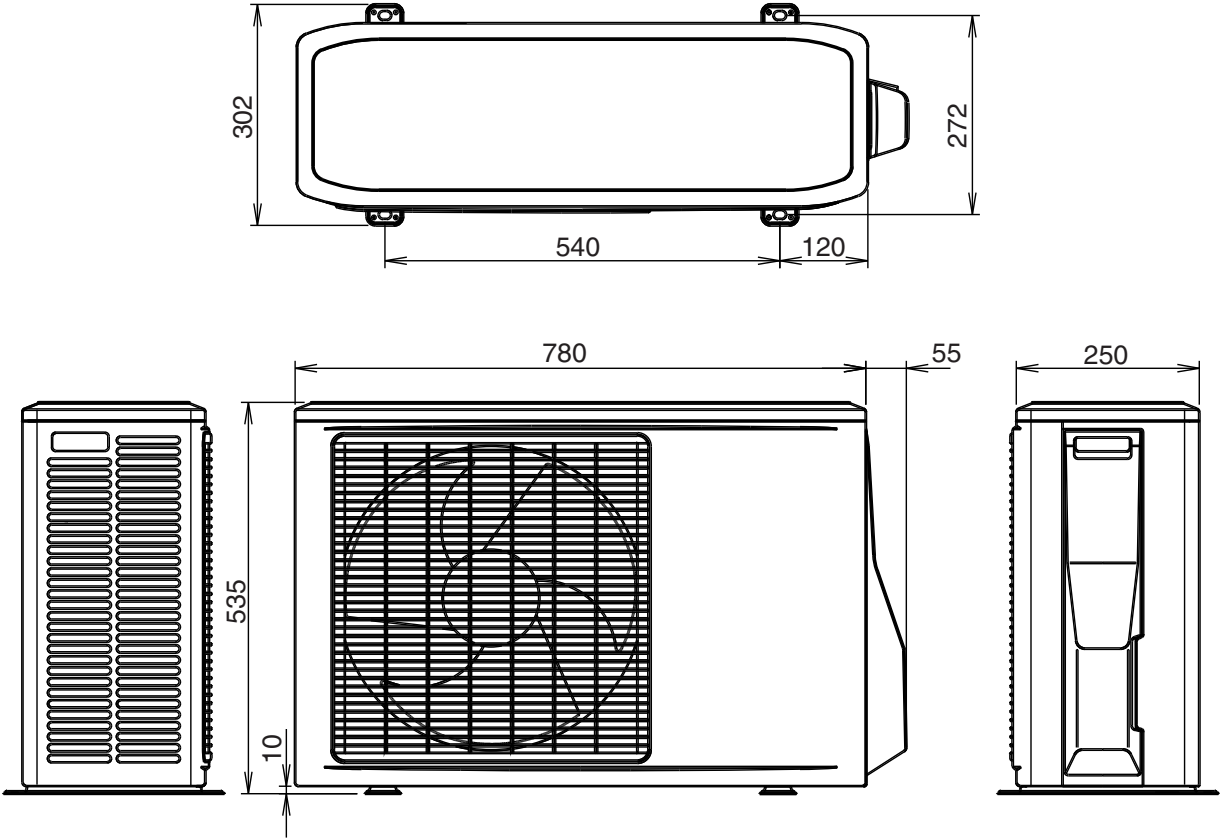

# REFRIGERANT SYSTEM DIAGRAM

**Models : ASH9USBCW / AOH9UGBC  
ASH12USBCW / AOH12UGBC**

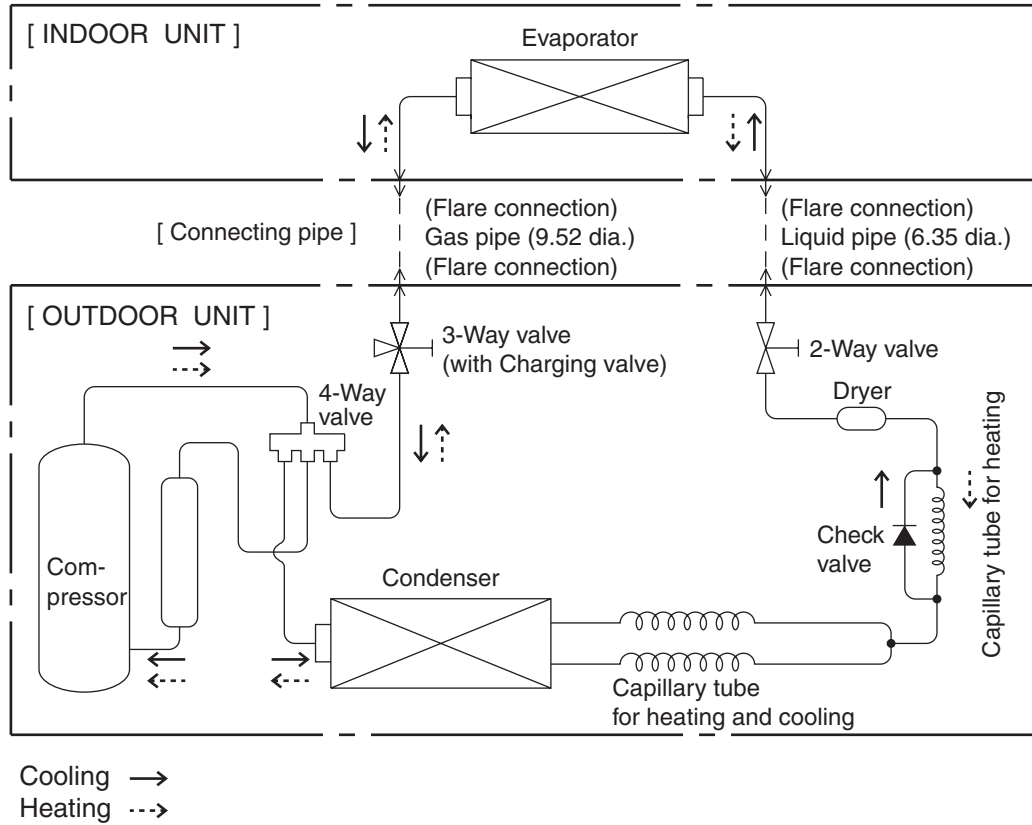

# CIRCUIT DIAGRAM

Model : ASH9USBCW  
ASH12USBCW

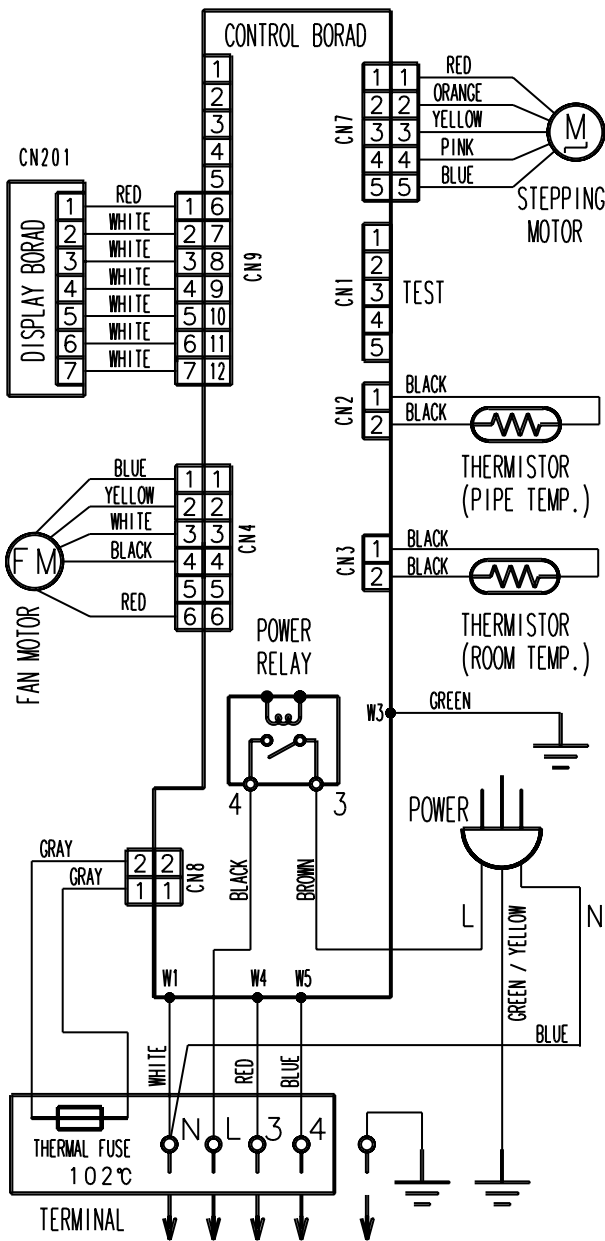

Model : AOY9UGBC  
AOY12UGBC

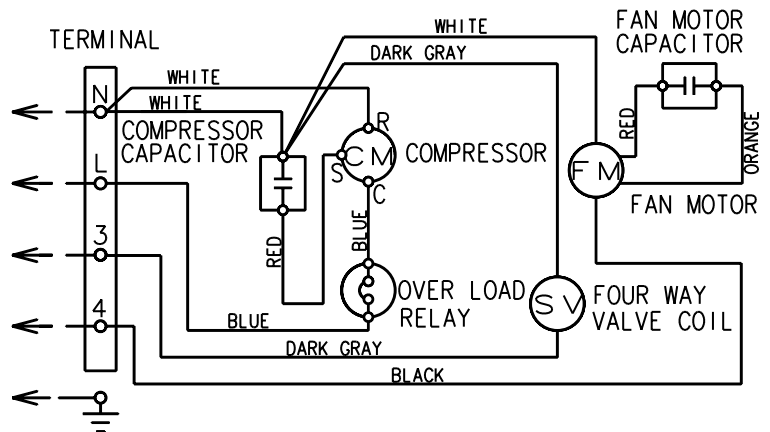

# INDOOR PRINTED CIRCUIT BOARD CIRCUIT DIAGRAM

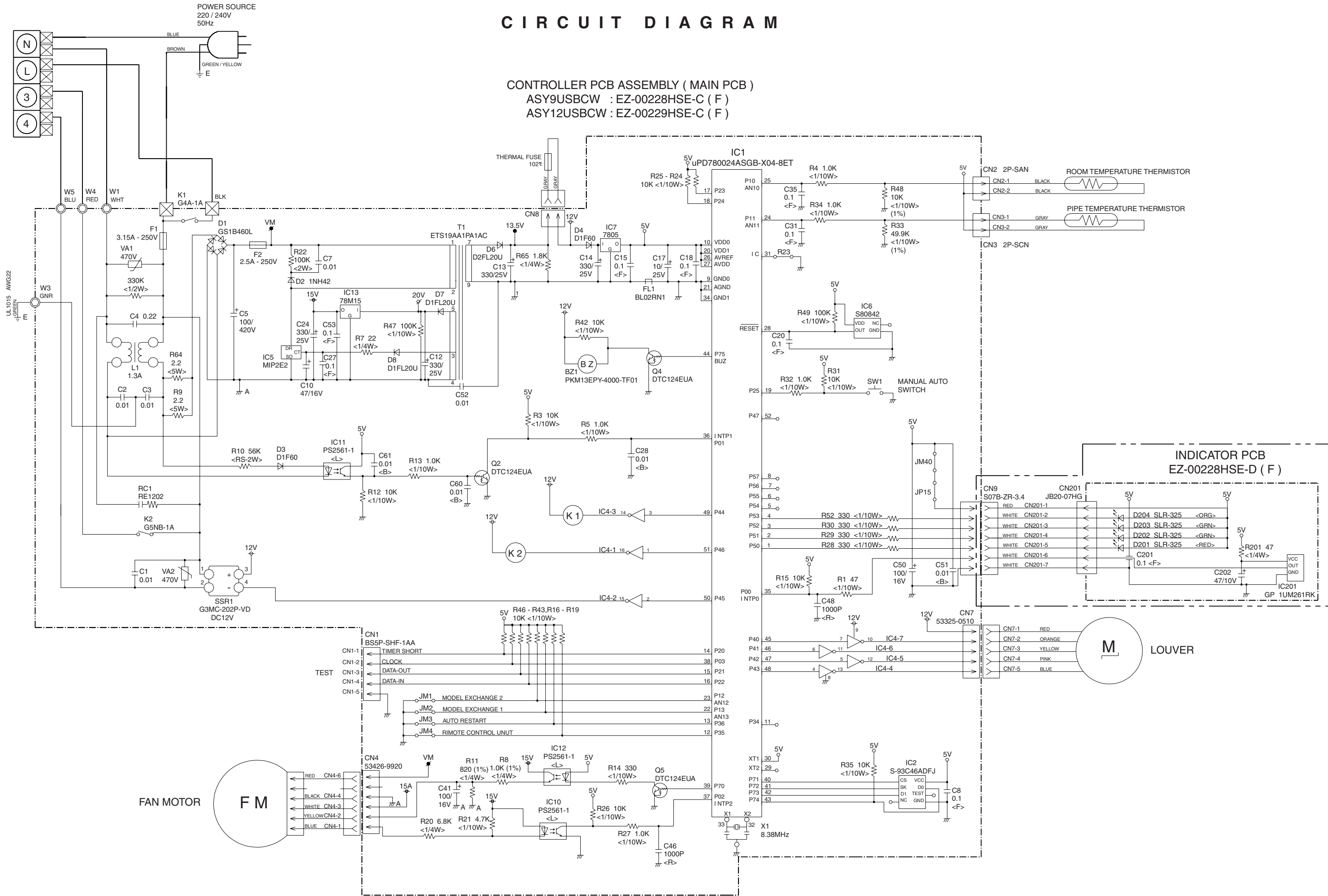



# ERROR DISPLAY

Troubleshooting check table

Operation lamp : Red lamp  
 Timer lamp : Green lamp

Large division indication			Small division indication		
Error contents	LED indication		Error contents	LED indication	
thermistor error	RED lamp	● (2 times)	thermistor error (room temp.)	RED lamp	○
	Green lamp	○		Green lamp	● (2 times)
control unit error (indoor unit )	RED lamp	● (4 times)	thermistor error (heat exchanger)	RED lamp	○
	Green lamp	○		Green lamp	● (3 times)
fan motor error (indoor unit)	RED lamp	● (6 times)	MANUAL AUTO button error	RED lamp	○
	Green lamp	○		Green lamp	● (2 times)
			power source Hz decision error	RED lamp	○
				Green lamp	● (4 times)
			lock error	RED lamp	○
				Green lamp	● (2 times)
			rpm error	RED lamp	○
				Green lamp	● (3 times)

● : 0.5s ON/OFF repeated

○ : 0.1s ON/OFF repeated

# DISASSEMBLY ILLUSTRATION

Model : ASH9USBCW  
ASH12USBCW

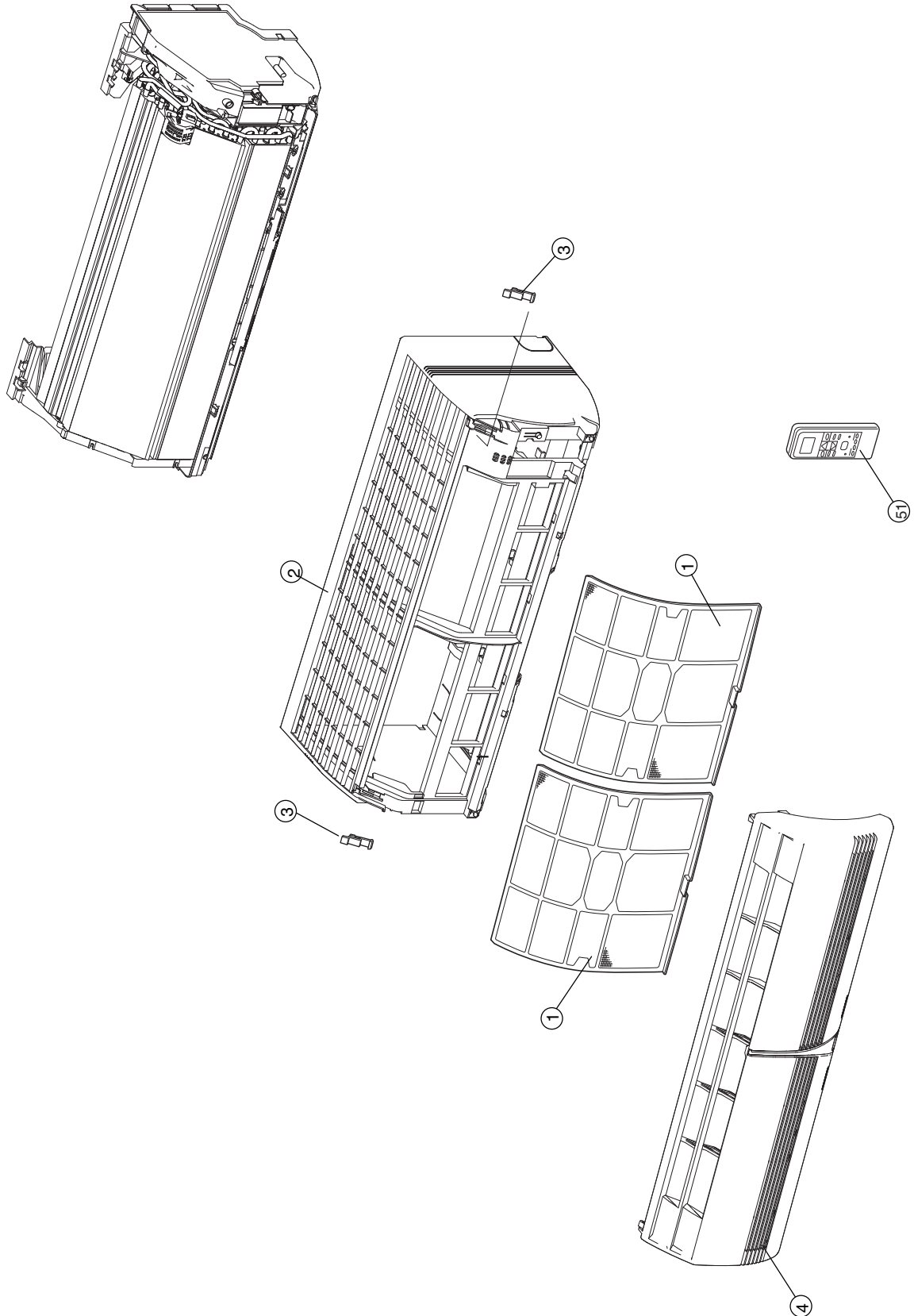

Models : ASH9USBCW  
ASH12USBCW

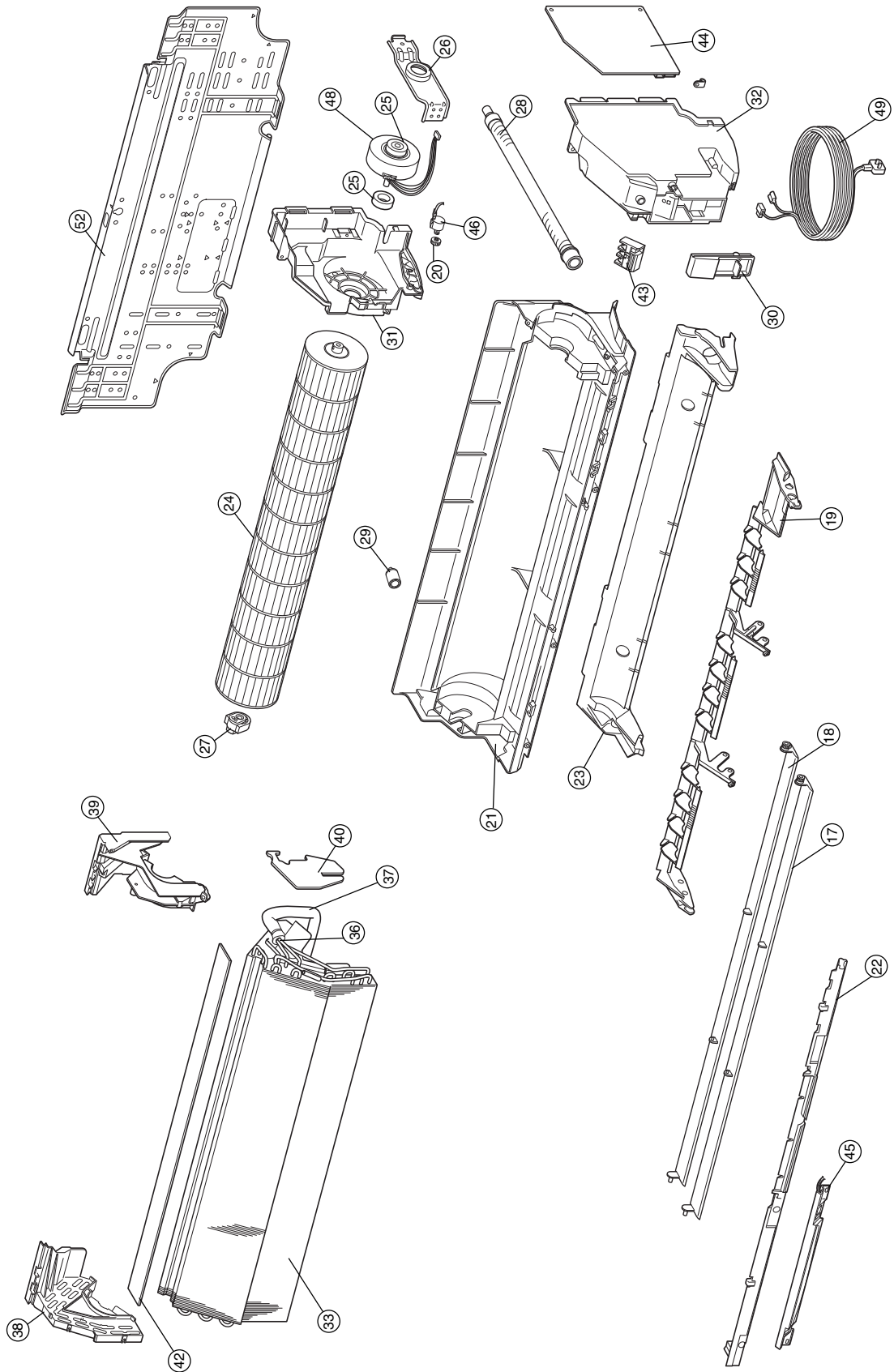

**Model : AOH9UGBC**

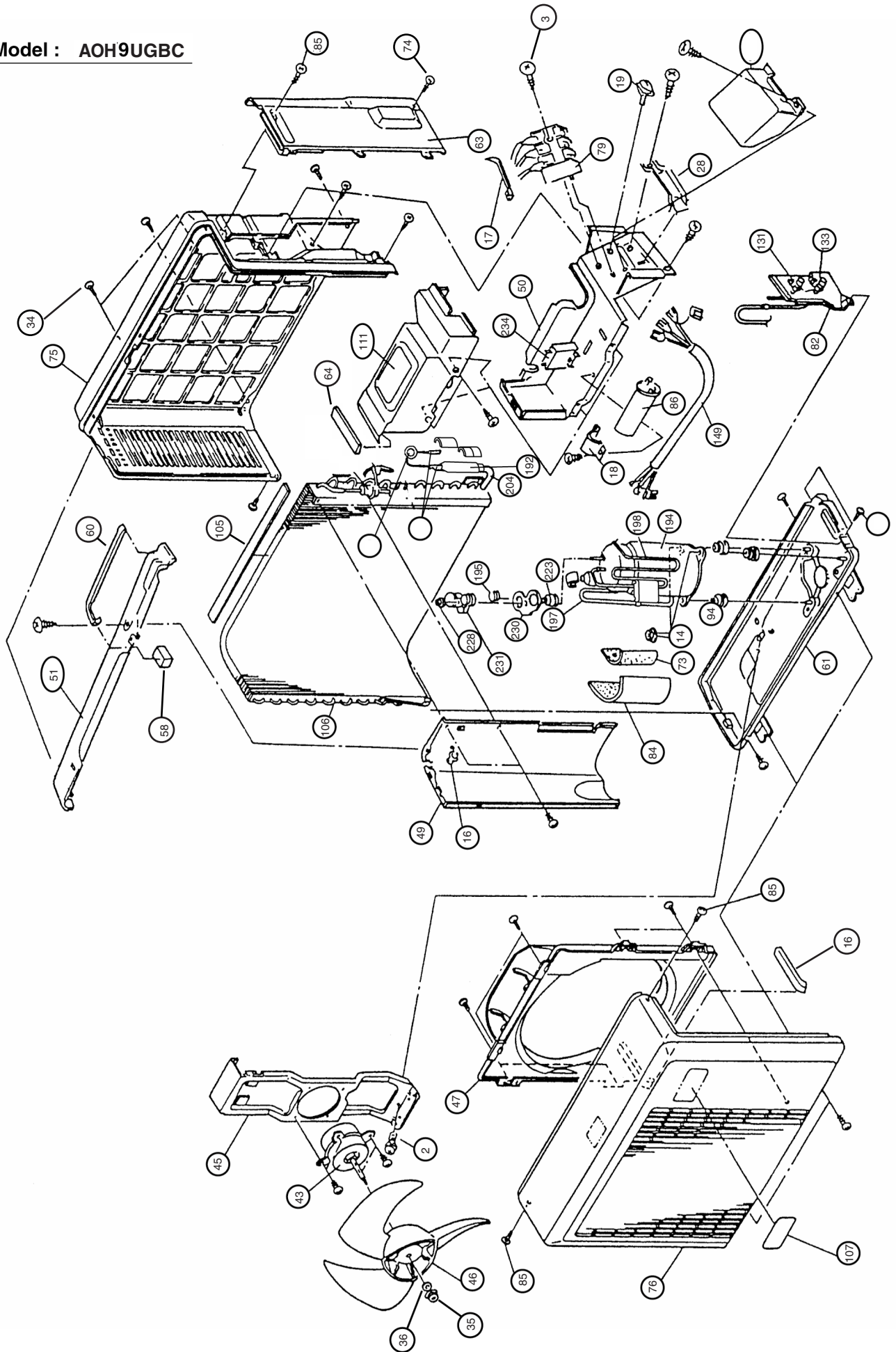

Model : AOH12UGBC

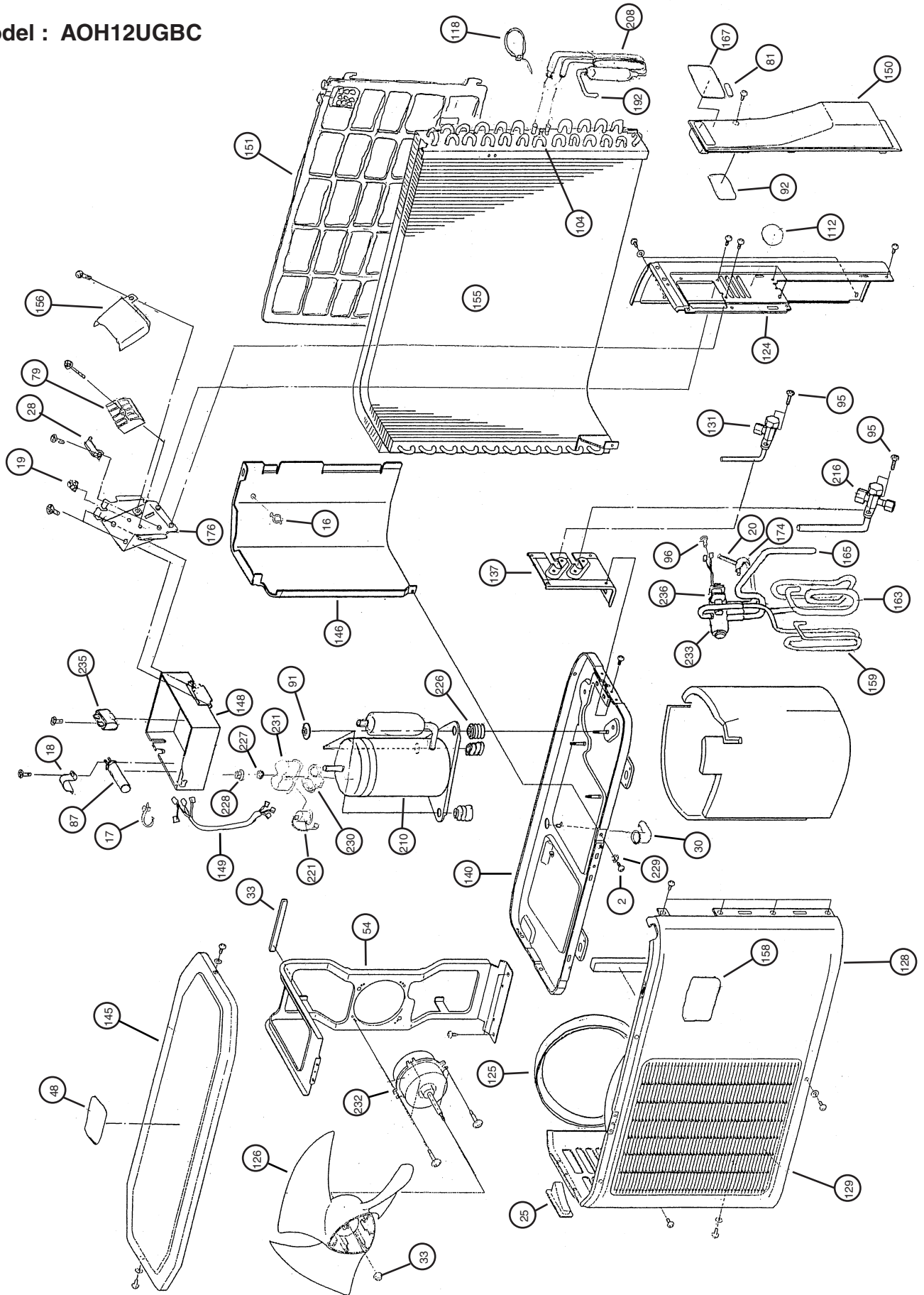

## P A R T S L I S T

When you order parts, please make a photocopy of this page  
and fill the number of the parts in the "Order" column.

### INDOOR UNIT

Ref. No.	Description	Part No.		Ord. Q'ty	Ref. No.	Description	Part No.		Ord. Q'ty
		ASH9USBCW	ASH12USBCW				ASH9USBCW	ASH12USBCW	
1	Air Filter	9309997011	9309997011		33	Evaporator Total Assy	9311495017	9311495017	
2	Front Panel	9309999039	9309999039		36	Joint Pipe-E Assy	9311497011	9311497011	
3	Clamper (Grille)	9306755010	9306755010		37	Insulation (Pipe)-E	9304607007	9304607007	
4	Intake Grille-B Assy	9312142026	9312142026		38	Holder (Evaporator)-L	9309982017	9309982017	
9	Face (Panel) Front-C	9311911012	9311911012		39	Holder (Evaporator)-R	9309983014	9309983014	
20	Gear-A	9309994003	9309994003		40	Water Seal	9310721001	9310721001	
21	Casing Assy	9312112036	9312112036		42	Air Seal	9310611005	9310611005	
23	Cover (Casing)-B	9311916017	9311916017		43	Terminal	9701955077	9701955077	
24	Crossflow Fan Assy	9307836016	9307836016		44	Controller PCB Assy	9704903044	9704903051	
25	Motor Cushion-B	9306274009	9306274009		46	Step Motor	9900139025	9900139025	
26	Clamper (Motor)	9310102008	9310102008		48	Fan Motor Assy-IN	9601351016	9601351016	
27	Shaft Holder-C Assy	9306628017	9306628017		51	Remote Control Unit	9312058020	9312058020	
28	Drain Hose Assy	9310357019	9310357019		52	Bracket Panel	9310001004	9310001004	
29	Drain Cap Assy	9304150008	9304150008		---	Flow Control Panel-U	9309991026	9309991026	
30	Wire Clamper	9311946014	9311946014		---	Flow Control Panel-Z	9309992023	9309992023	
31	Box (Switch)	9309996014	9309996014		---	Power Cord	9702595050	9702595050	
32	Cover (Switch)	9311863014	9311863014		---	Indicator PCB Assy	9705039025	9705039025	

When you order parts, please make a photocopy of this page and fill the number of the parts in the "Order" column.

OUTDOOR UNIT (AOH9UGBC)

Ref. No.	Description	Part No. AOH9UGBC	Ord. Q'ty	Ref. No.	Description	Part No. AOH9UGBC	Ord. Q'ty
2	Screw, Taptite (Earth)	0700179013		93	Fan Motor	9307715013	
3	Screw	301171134250		94	Rubber Cushion	9307761010	
4	Screw	301171164104		105	Heat Insulation (Cond)	9308457011	
5	Screw	301171164146		106	Condenser	9308460035	
8	Washer, Flat	301812440114		107	Emblem-Rear	9308474018	
13	Clamp SKB-150	313035356905		111	Control Box Cover-A	9308562012	
14	Special Nut M8	313252257701		118	Clamp	9309608016	
16	Clamp No.1219	313361271706		130	Label	9310053430	
17	Clamp SKB-100	313361275805		131	2-Way Valve	9310084014	
18	Capacitor Clamp	313468061808		133	3-Way Valve	9310085011	
19	Screw with Washer	313681304205		149	Sealed Tube	9310973011	
28	Cord Clamp	9302271002		192	Dryer	9312056002	
30	Drain Pipe Assy	9303029015		194	Compressor	9312272013	
34	Screw, Painted	9304885009		195	OCR	9312273003	
35	Special Nut with Washer	9304902003		197	Discharge Pipe	9312275007	
36	Special Washer	9304903000		198	Suction Pipe	9312276004	
41	Clamp SKB-3MC	9305335008		199	entrance Pipe	9312277018	
45	Bracket (Motor)	9305536030		204	Capillary	9312282012	
46	Propeller Fan	9305538003		223	Connection Pipe	9312539000	
47	Fan Ring	9305581023					
48	Label (Warning)	9305870028		228	Nut	9359430018	
49	Special Wall	9305971008		229	Solenoid	9360538031	
50	Cntrol Box Metal	9305972005		230	Terminal Gasket	9362004008	
51	Reinforcement Plate	9305973002		231	Terminal Cover	9363263008	
58	Cushion	9306092009		233	4-Way Valve	9900047016	
60	Seal	9306117009		234	Running Capacitor	9900089023	
61	Base	9306118099					
63	Connector Cover	9306119010					
64	Seal	9306124007					
66	Seal	9306178000					
73	Noise Insulation-G	9306362003			BR Sheet 30x120x T7	9305039036	
74	Screw	9306379001			BR Sheet 180x180x T2	9305039067	
75	Cabint Rear Panel	9306385019			BR Sheet 20x120x T5	9305039104	
76	Front Panel	9306386016					
79	Terminal	9306488017					
82	Bracket (Valve)	9306748012					
84	Noise Insulation-F	9306937010					
85	Screw	9307303012					
86	Running Capacitor	9307588020					
92	Label (Outoer Circuit)	9307659010					





When you order parts, please make a photocopy of this page and fill the number of the parts in the "Order" column.

OUTDOOR UNIT (AOH12UGBC)

Ref. No.	Description	Part No.	Ord. Q'ty	Ref. No.	Description	Part No.	Ord. Q'ty
		AOH12UGBC				AOH12UGBC	
2	Screw, Taptite (Earth)	0700179013		150	Cover (Switch)	9310979013	
3	Screw	301171134250		151	Protection Net	9310980019	
16	Clamp No.1219	313361271706		155	Condenser	9311003014	
17	Clamp SKB-100	313361275805		156	Cover (Terminal)	9311021018	
18	Capacitor Clamp	313468061808		158	Emblem-Rear	9311087007	
19	Screw with Washer	313681304205		159	Discharge Pipe	9311045007	
20	Air Pipe	9300895002		163	Suction Pipe	9311075004	
25	Grip	9302061016		165	Joint Pipe	9311079002	
28	Cord Clamp	9302271002		167	Label	9311083016	
30	Drain Pipe Assy	9303029015		169	Top Seal-B	9311088004	
33	Heat Insulation (Motor)	9304859000		170	Cabinet Seal-B	9311096009	
35	Special Nut with Washer	9304902003		171	Cabinet Seal-A	9311097006	
48	Label (Warning)	9305870028		172	Top Seal-A	9311099000	
54	Bracket (Motor)	9306047030		174	Entrance Pipe	9311105008	
79	Terminal	9306488017		176	Bracket (Terminal)	9311347026	
81	Label (origin)	9306536015		177	Noise Insulation-C	9311480013	
87	Running Capacitor	9307588068		186	Noise Insulation-F	9911642015	
91	Special Nut	9307615016		192	Dryer	9312056002	
92	Label (Outer Circuit)	9307659010		210	Compressor	9312288014	
95	Hex Bolt	9307835001		211	OCR	9312289004	
96	Screw	9308037008		213	Capillary	9312291014	
104	U-Pipe Y	9308442000		216	3-Way Valve	9312295012	
112	Label (Warning)	9308567017		224	Washer	9351522018	
118	Clamp	9309608016		226	Rubber Sheat-A	9359425014	
124	Panel Rear	9309870024		227	Terminal Washer	9359428015	
125	Fan Ring	9309876019		228	Nut	9359430018	
126	Propeller Fan	9309909014		230	Terminal Gasket	9362004008	
128	Cabinet, Painted	9309928053		231	Terminal Cover	9363263008	
129	Blow Grill	9309929012		232	Motor, Induct	9601541011	
131	2-Way Valve	9310084014		233	4-Way Valve	9900047016	
137	BCT (Valve)	9310229026		235	Running Capacitor	9900089030	
140	Base, Painted	9310248027		236	Solenoid	9970026010	
145	Panel (Top), Painted	9310338063			BR Sheet 30x120x T7	9305039036	
146	Separator	9310969014			BR Sheet 180x180x T2	9305039067	
148	Box (Switch)	9310971017			BR Sheet 20x120x T5	9305039104	
149	Sealed Tube	9310973011					

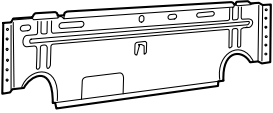

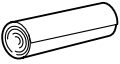
# STANDARD ACCESSORIES

Name and Shape	Part No.
Wall hook bracket 	9310001004
Remote control unit 	9312094059
Battery (penlight) 	0600185534
Cloth tape 	9310519004
Tapping screw (4 x 25) 	0700076046

