



# SPLIT TYPE ROOM AIR CONDITIONER

**WALL MOUNTED** type

# SERVICE MANUAL

Models	Indoor unit	Outdoor unit
	ASH9RSJCW	AOH9RSJC
	ASH12RSJCW	AOH12RSJC

## C O N T E N T S

SPECIFICATIONS .....	1
DIMENSIONS .....	3
REFRIGERANT SYSTEM DIAGRAM .....	5
CIRCUIT DIAGRAM .....	6
CONTROLLER PCB ASSEMBLY .....	7
ERROR DISPLAY.....	8
DISASSEMBLY ILLUSTRATION .....	9
PARTS LIST .....	13
STANDARD ACCESSORIES .....	15

# S P E C I F I C A T I O N S

TYPE		COOLING & HEATING		COOLING & HEATING	
MODEL	IN	ASH9RSJCW		ASH12RSJCW	
	OUT	AOH9RSJC		AOH12RSJC	
COOLING CAPACITY	kW	2.50		3.25	
HEATING CAPACITY	kW	2.95		3.80	

## ELECTRICAL DATA

POWER SOURCE		230V 50Hz		230V 50Hz	
RUNNING CURRENT (A)	COOL	4.8		6.2	
	HEAT	4.3		5.7	
INPUT WATTS (kW)	COOL	1.00		1.31	
	HEAT	0.86		1.22	
E.E.R. (kW/kW)	COOL	2.50		2.48	
	HEAT	3.43		3.11	
MOISTURE REMOVAL	ℓ /h	1.3		1.8	
AIR CIRCULATION-Hi	(m <sup>3</sup> /hr)	COOL 540 HEAT 515		COOL 535 HEAT 545	

## COMPRESSOR

TYPE	Hermetic type, Permanet split condenser, 2 pole, Single phase, Induction motor				
CODE	80603745	220,230,240V/50Hz	80679045Z,80679045N	220,230,240V/50Hz	
REFRIGERANT R-22 (g)	650			770	

## FAN MOTOR

POWER SUPPLY (V)		230				230			
INDOOR UNIT	HI-SPEED (r.p.m.)	COOL	1310	HEAT	1250	COOL	1310	HEAT	1330
	MED-SPEED (r.p.m.)	COOL	1170	HEAT	1140	COOL	1200	HEAT	1210
	LO-SPEED (r.p.m.)	COOL	1030	HEAT	1020	COOL	1090	HEAT	1090
	QUIET (r.p.m.)	COOL	900	HEAT	900	COOL	980	HEAT	980
OUTDOOR UNIT (r.p.m.)	800				770				

## DIMENSIONS

INDOOR UNIT	H x W x D (mm)	257 x 808 x 187		257 x 808 x 187	
OUTDOOR UNIT		535 x 650 x 250		535 x 695 x 250	

## WEIGHT

INDOOR UNIT	NET / GROSS (kg)	10 / 8		10 / 8	
OUTDOOR UNIT		28 / 25		34 / 31	

## NOISE LEVEL

INDOOR UNIT	HI-SPEED (dB)	COOL	39	HEAT	37	COOL	40	HEAT	40	
	MED-SPEED (dB)	COOL	35	HEAT	34	COOL	39	HEAT	39	
	LO-SPEED (dB)	COOL	33	HEAT	31	COOL	37	HEAT	37	
	SUPER QUIET (dB)	COOL	29	HEAT	27	COOL	34	HEAT	34	
OUTDOOR UNIT (dB)	COOL		46	HEAT	46	COOL		47	HEAT	48

## ADDITIONAL CHARGE OF REFRIGERANT

Refrigerant suitable for a piping length of 7.5m is charged in the outdoor unit at the factory.

When the piping is longer than 7.5m, additional charging is necessary. For the additional amount, see the table below.

### ASH9RSJCW / AOH9RSJC

Pipe length	7.5m	10m
Additional refrigerant	None	40g

Between 7.5m and 10m, when using a connection pipe other than that in the table, charge additional refrigerant with 16g/1m as the criteria.

(The maximum length of the piping is 10m. If the units are further apart than this, correct operation can not be guaranteed.)

### ASH12RSJCW / AOH12RSJC

Pipe length	7.5m	10m	15m
Additional refrigerant	None	40g	120g

Between 7.5m and 15m, when using a connection pipe other than that in the table, charge additional refrigerant with 16g/1m as the criteria.

(The maximum length of the piping is 15m. If the units are further apart than this, correct operation can not be guaranteed.)

# D I M E N S I O N S

## INDOOR UNIT

Models : ASH9RSJCW  
ASH12RSJCW

Unit : mm

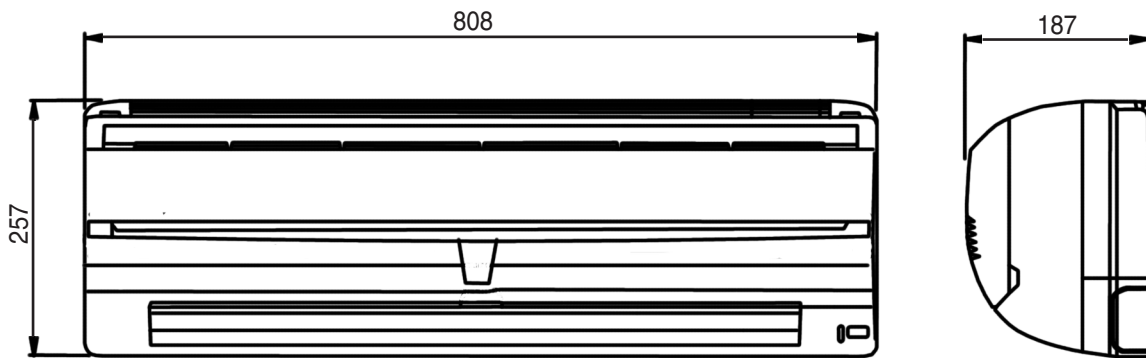

# OUTDOOR UNIT

Model : AOH9RSJC

Unit : mm

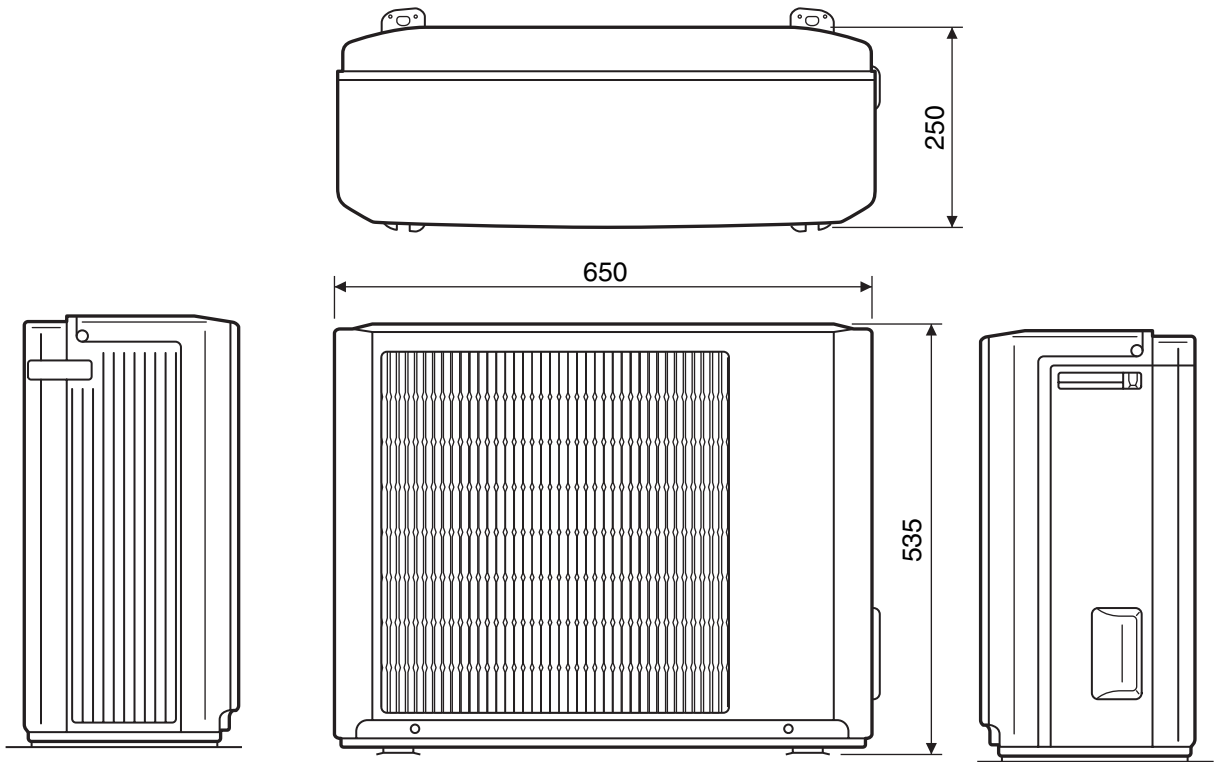

Model : AOH12RSJC

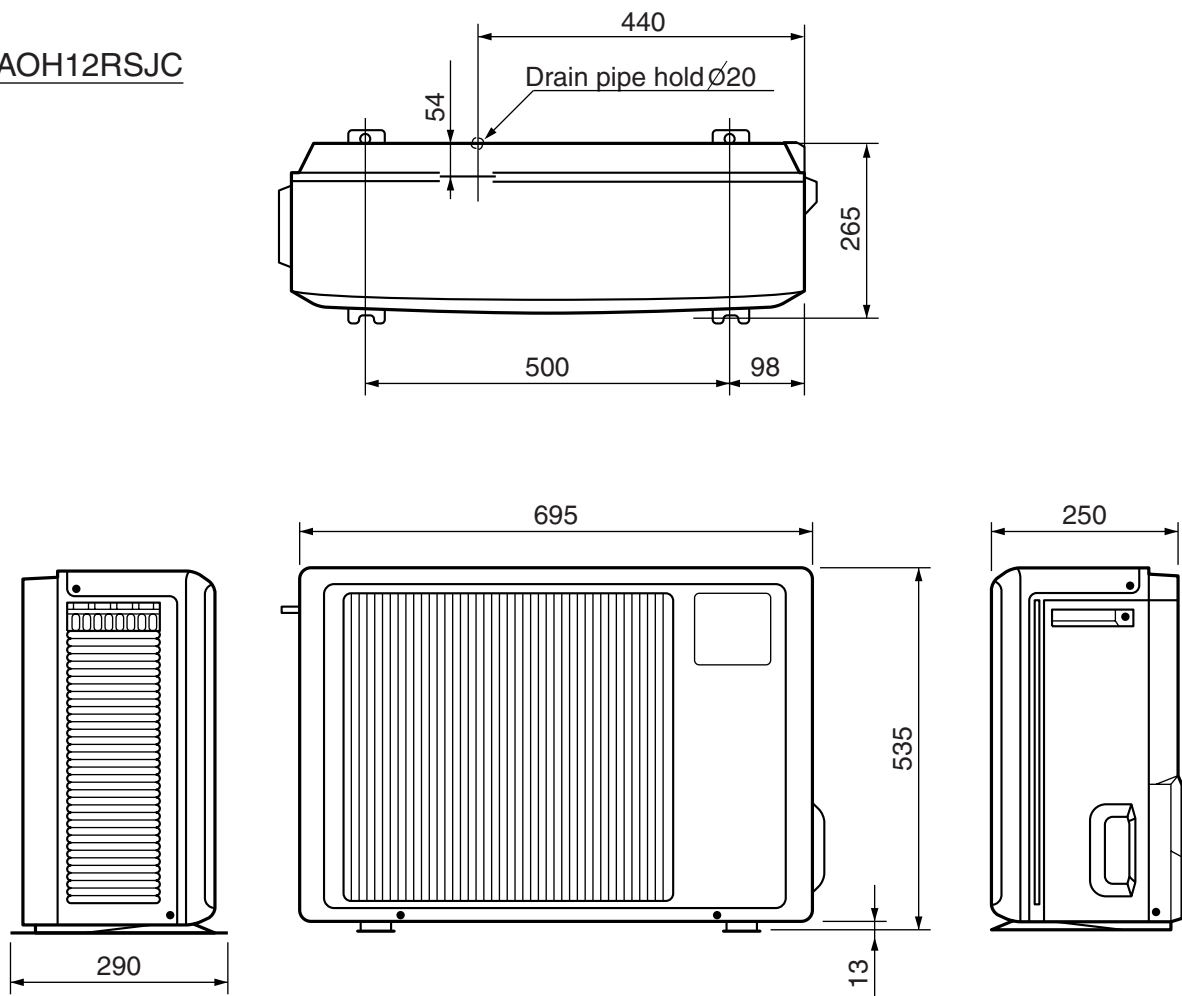

# REFRIGERANT SYSTEM DIAGRAM

**Model : ASH9RSJCW / AOH9RSJC**

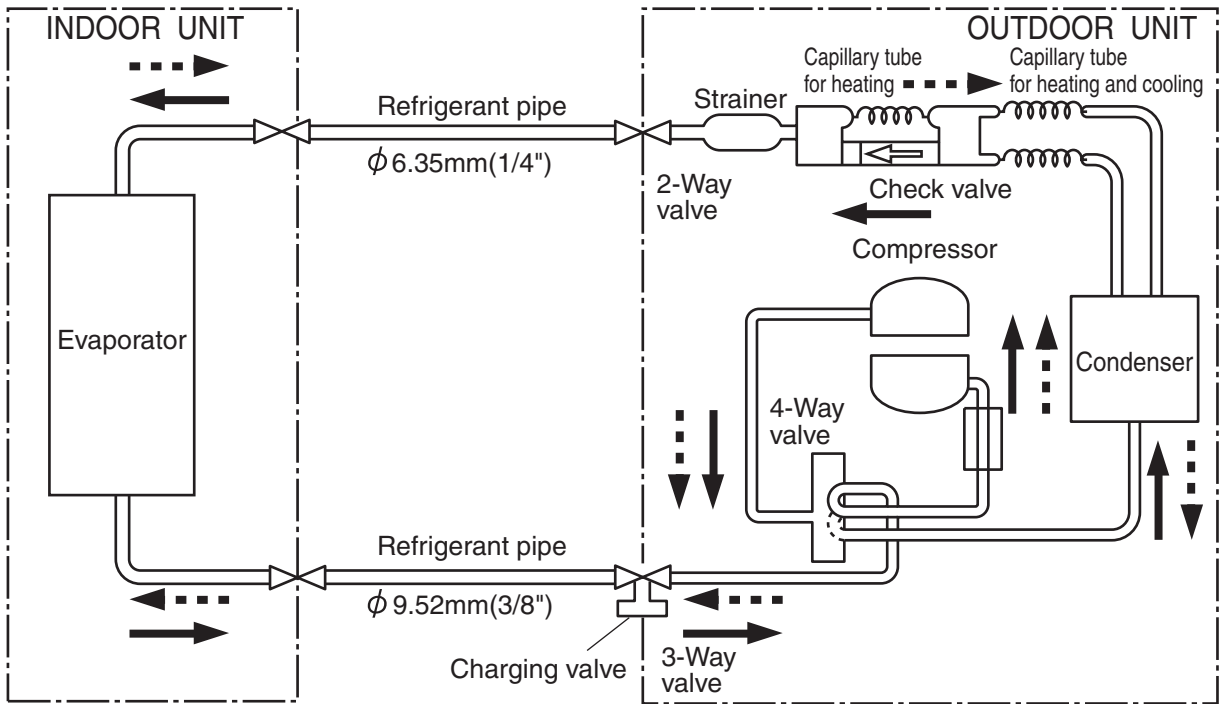

**Models : ASH12RSJCW / AOH12RSJC**

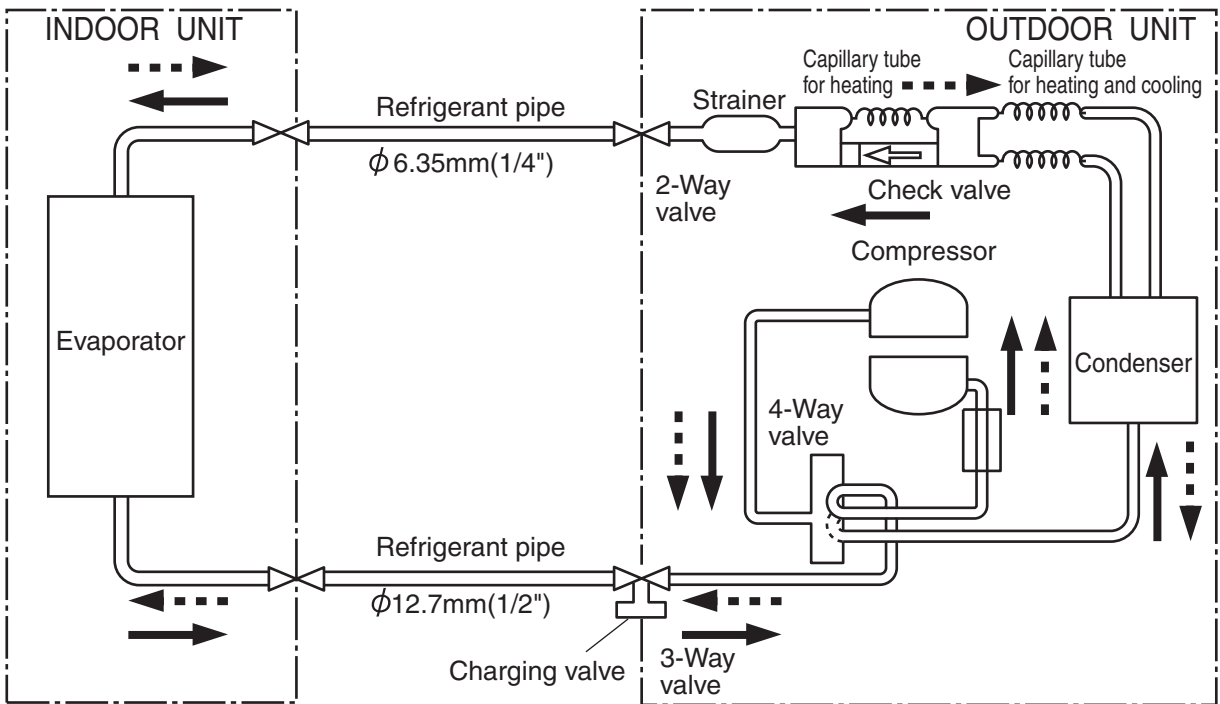

# DISASSEMBLY ILLUSTRATION

Models : ASH9RSJJCW  
ASH12RSJJCW

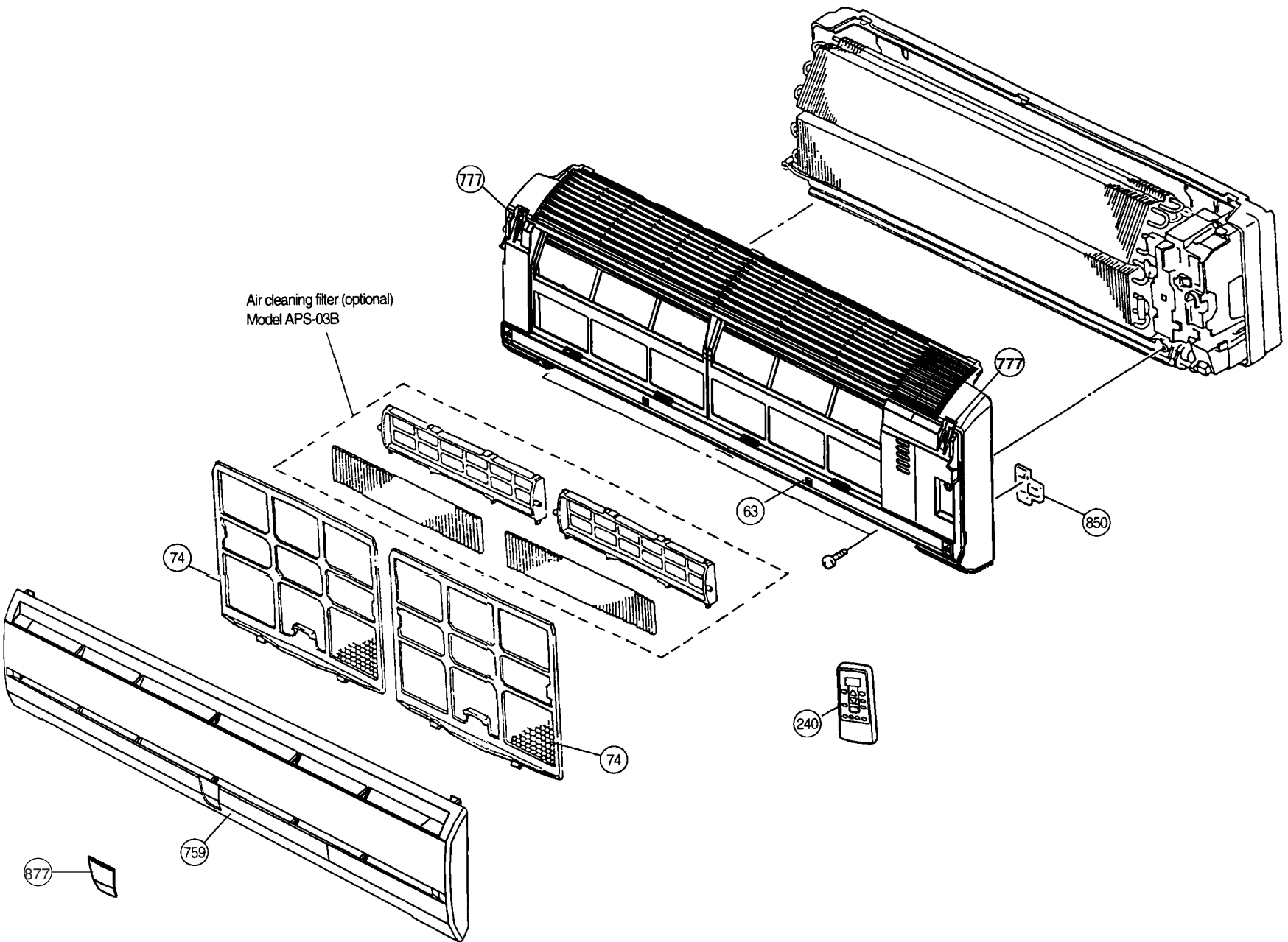

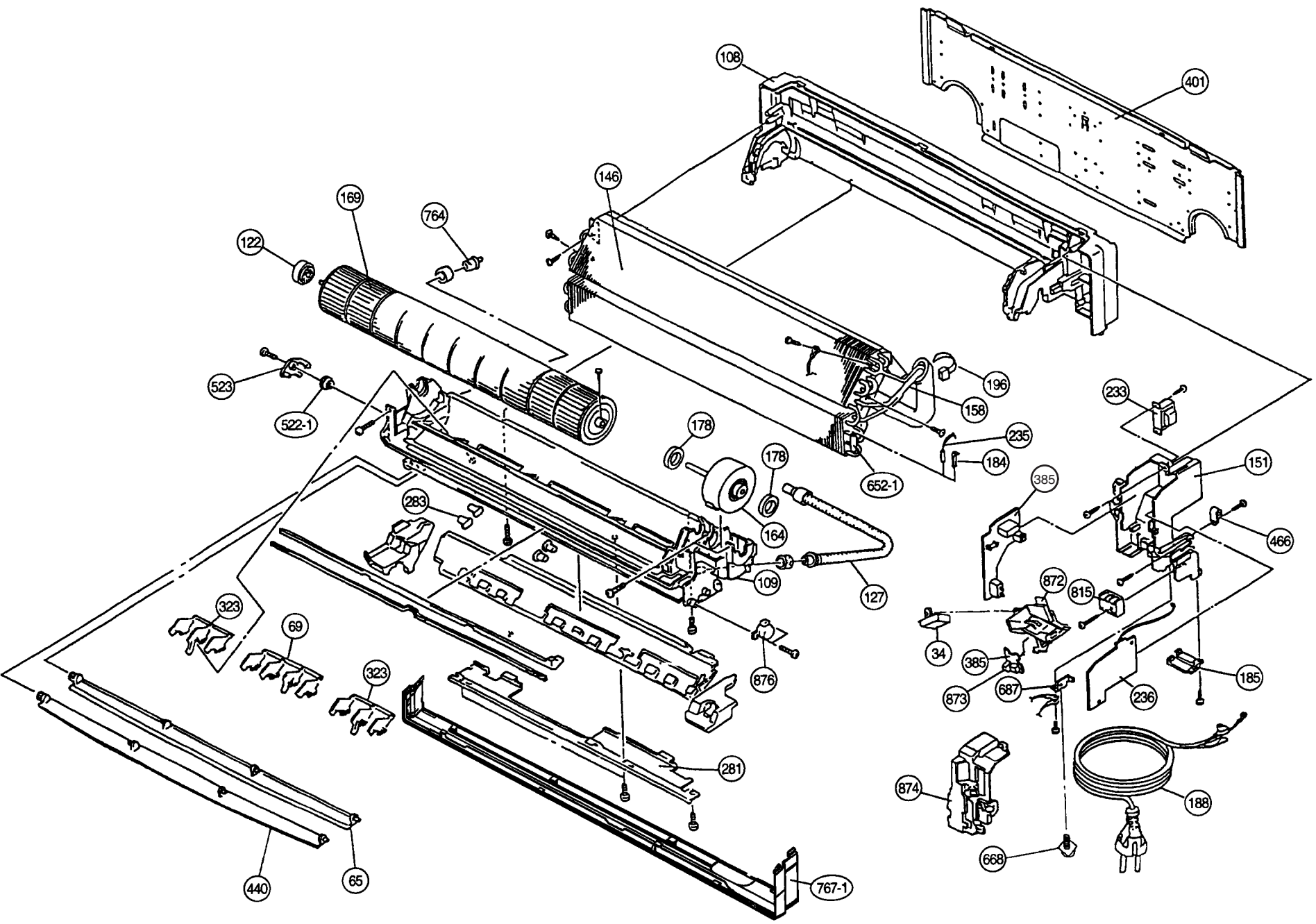



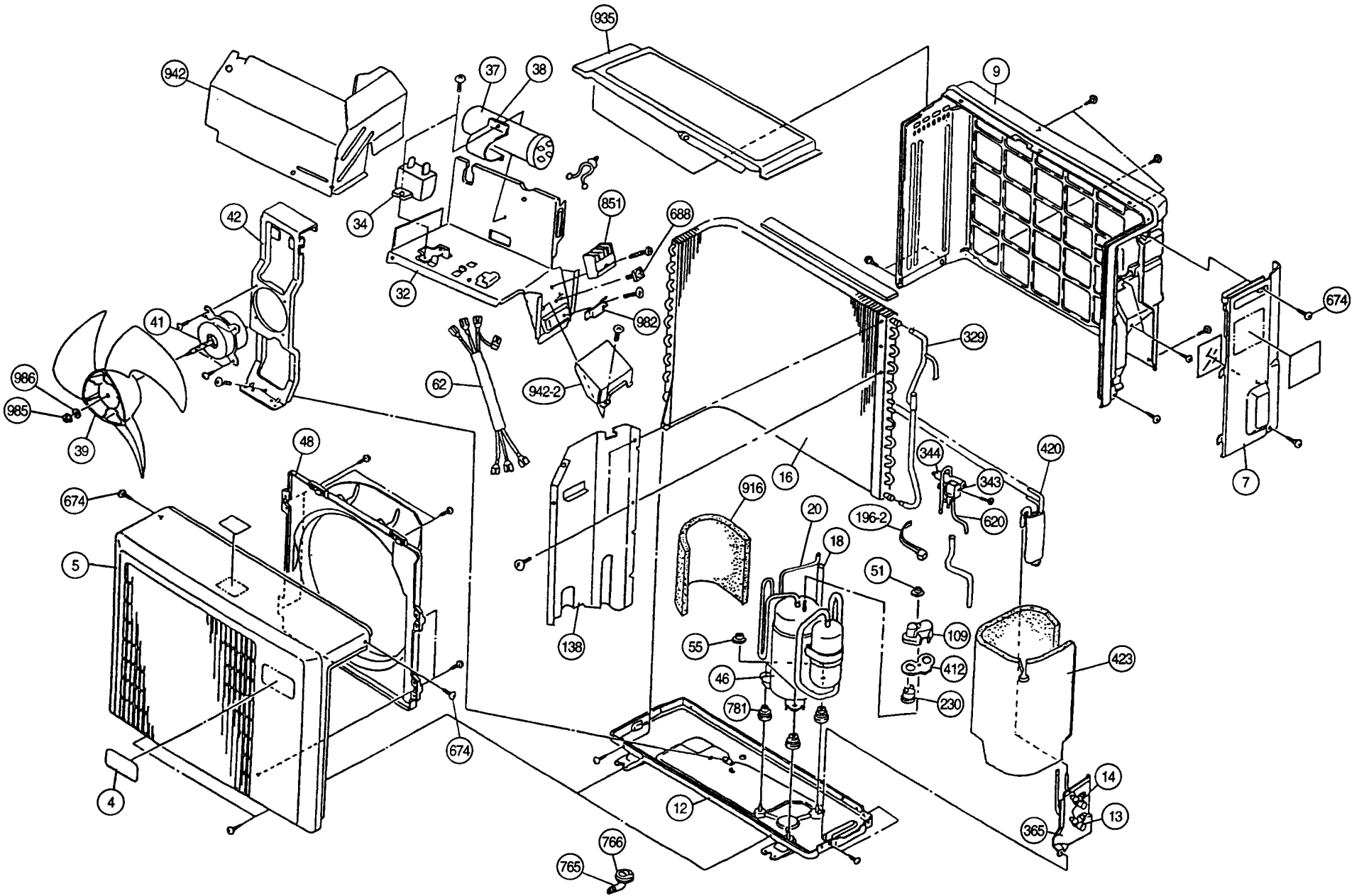

Model : AOH12RSJC

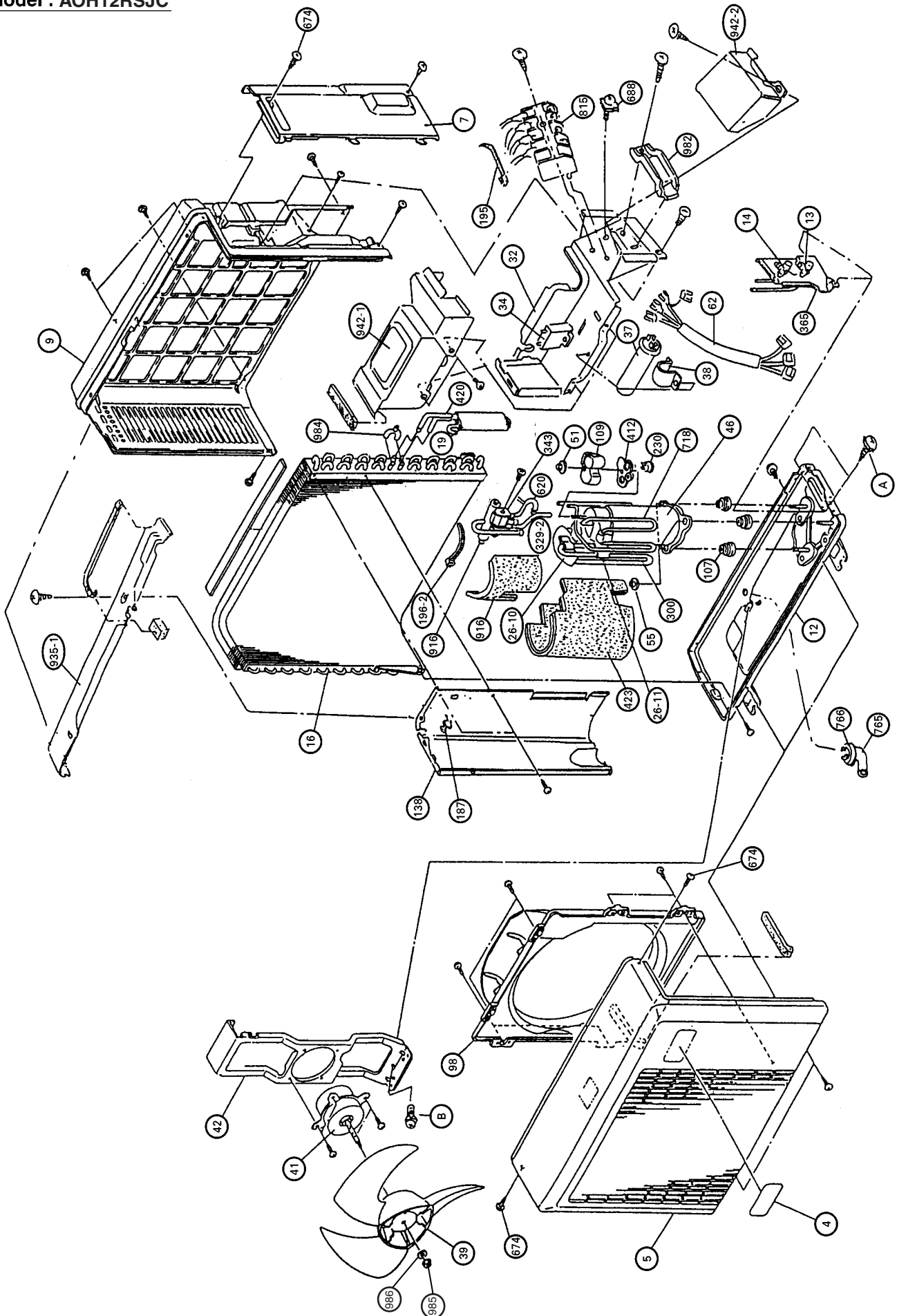

# CIRCUIT DIAGRAM

Models : ASH9RSJCW  
ASH12RSJCW

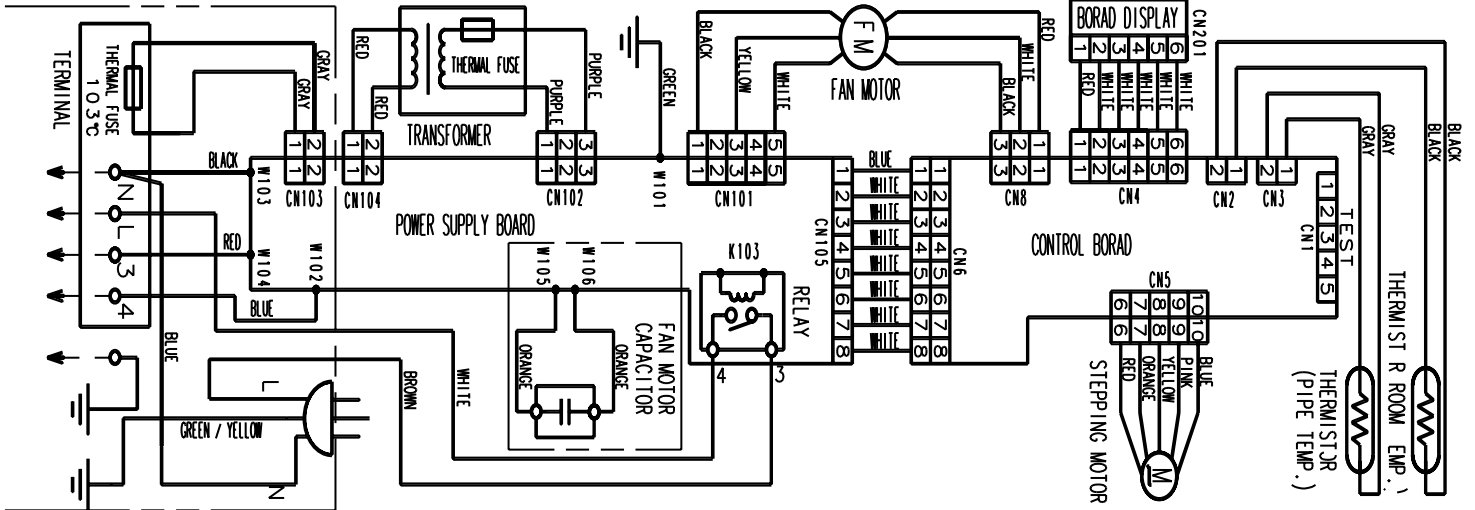

Models : AOH9RSJC  
AOH12RSJC

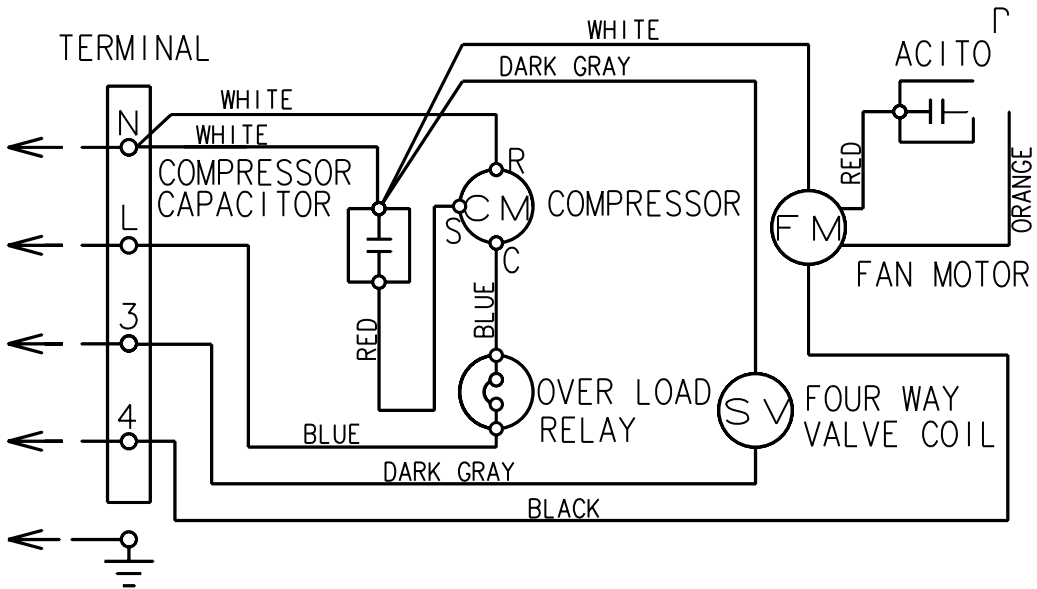

# INDOOR PRINTED CIRCUIT BOARD CIRCUIT DIAGRAM

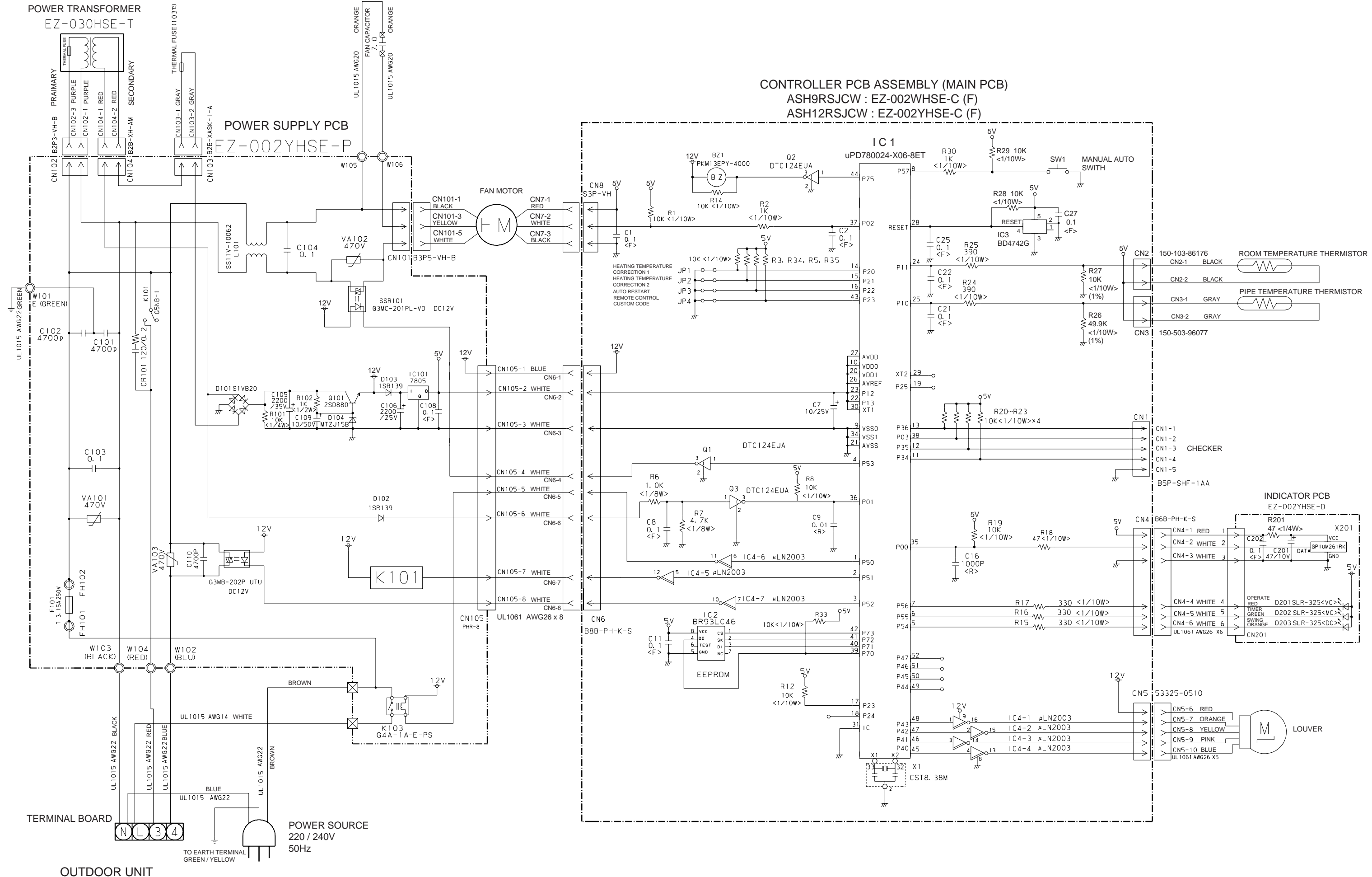

# E R R O R   D I S P L A Y

Troubleshooting check table

Operation lamp : Red lamp  
 Timer lamp : Green lamp

Large division indication			Small division indication		
Error contents	LED indication		Error contents	LED indication	
thermistor error	RED lamp	● (2 times)	thermistor error (room temp.)	RED lamp	○
	Green lamp	○	thermistor error (heat exchanger)	Green lamp	● (2 times)
control unit error (indoor unit )	RED lamp	● (4 times)	MANUAL AUTO button error	RED lamp	○
	Green lamp	○	power source Hz decision error	Green lamp	● (2 times)
fan motor error (indoor unit)	RED lamp	● (6 times)	lock error	RED lamp	○
	Green lamp	○	rpm error	Green lamp	● (2 times)
				RED lamp	○
				Green lamp	● (3 times)

● : 0.5s ON/OFF repeated  
 ○ : 0.1s ON/OFF repeated

## PARTS LIST

When you order parts, please make a photocopy of this page and fill the number of the parts in the "Order" column.

### INDOOR UNIT

Ref. No.	Description	Part No.		Ord. Q'ty	Ref. No.	Description	Part No.		Ord. Q'ty
		ASH9RSJCW	ASH12RSJCW				ASH9RSJCW	ASH12RSJCW	
34	Capacitor (Fan Motor)	9900089061	9900089061		281	Clamp Metal (Pipe)	9306063009	9306063009	
63	Panel (Front) Total Assy	9312172061	9312172023		283	Bushing-A	9303529010	9303529010	
65	Flow Control Panel-Z	9306058012	9306058012		323	Louver-B	9306056025	9306056025	
69	Louver-A	9306055028	9306055028		385	PCB (Power and Indicator)	9704870018	9704870018	
74	Filter	9305444014	9305444014		401	Wall Hook Bracket	9304358008	9304358008	
108	Base	9309755062	9309755062		440	Flow Control Panel-U	9306057015	9306057015	
109	Casing	9306052027	9306052027		466	Clamp NK-4N	313714328805	313714328805	
122	Shaft Holder-B	9303066010	9303066010		522-1	Gear-A	9306062002	9306062002	
127	Drain Hose Assy	9305550029	9305550029		523	Gear Bracket	9306407001	9306407001	
146	Evaporator Assy	9308555069	9308555069		652-1	Thermistor Holder Pipe	313714262805	313714262805	
151	Control Box	9330007017	9330007017		668	Screw w/Washer	313681304205	313681304205	
158	Connecting Pipe Assy	9306416010	9306699000		687	Earth Terminal	9330012011	9330012011	
164	Fan Motor Assy-IN	9601172017	9601172017		759	Intake Grille-B	9330002012	9330002012	
169	Cross-Flow Fan Assy	9305435012	9305435012		764	Drain Cap Assy	9304150008	9304150008	
178	Motor Cushion-M	9601302018	9601302018		767-1	Bottom Cover-A	9330004016	9330004016	
184	Thermistor Spring	313728262708	313728262708		777	Clamper(Grille)	9306755010	9306755010	
185	Wire Clamp	9330015012	9330015012		815	Terminal	9900040048	9900040048	
188	Power Cord Assy	9702595043	9702595043		850	Window (Receiver)	9330003019	9330003019	
196	Clamp SKB-150	313035356905	313035356905		872	Indicator Case	9330009011	9330009011	
233	Power Transformer	9701803026	9701803026		873	Lamp Cover	9330014015	9330014015	
235	Thermistor Assy-Pipe	9702039059	9702039059		874	Control Box Cover	9330008014	9330008014	
236	Controller PCB Assy	9704865038	9704865014		876	Step Motor	9900139018	9900139018	
240	Remote Control Unit	9312058020	9312058020		877	Face Panel (Front)-B	9330006034	9330006034	

When you order parts, please make a photocopy of this page and fill the number of the parts in the "Order" column.







OUTDOOR UNIT

Ref. No.	Description	Part No.		Ord. Q'ty	Ref. No.	Description	Part No.		Ord. Q'ty
		AOH9RSJC	AOH12RSJC				AOH9RSJC	AOH12RSJC	
4	Emblem-Rear	9306337001	9306094003		412	Terminal Gasket (For Comp.)	9312162000	9307089008	
5	Cabinet Front Panel, Plastic	9306016012	9306386016		420	Capillary Assy	9312157013	9308960009	
7	Connector Cover	9306018016	9306119010		423	Noise Insulation-B	9311106005	9306424008	
9	Cabinet Rear Panel, Plastic	9306017019	9306385019		582	Discharge Pipe-SF	9306115005	9306115005	
12	Base Assy, Painted	9304806042	9306118020		674	Screw, SUS410T+5014	9305848010	9305848010	
13	3-Way Valve	9311573012	9311534013			Screw, Tapping SUS410T+4010	9306379001	-----	
14	2-Way Valve	9311571018	9311533016		A	Screw (For Earth)	9357297002	-----	
16	Condenser Assy	9311928010	9330031012		688	Screw w/Washer	313681304205	313681304205	
18	Suction Pipe Assy	9311092001	9308036001		765	Drain Pipe (L-type)	-----	9301102000	
20	Discharge Pipe	9311090007	9307035012		766	Drain Pipe Packing	-----	9301143003	
								-----	
32	Control Box Metal	9306475024	9305972005		781	Rubber Cushion	9309911017		
34	Capacitor (Fan Motor)	9900089023	9900089030		815	Terminal-4P	9306488017	9306488017	
37	Capacitor (Running)	9307588013	9307588013		820	Joint Pipe (Capillary)	9305680009	-----	
38	Clamp Metal (Capacitor)	313468061808	313468061808		916	Noise Insulation-A	9311107002	9306362003	
39	Propeller Fan	9306565015	9305538003		935	Reinforcement Plate	9306473006	-----	
41	Fan Motor Assy-Out	9307095016	9307715013		935-1	Reinforcement(Cabinet Top)	-----	9305973002	
42	Bracket (Motor)	9306021016	9305536016		935-2	Reinforcement-F (Cabinet Top)	-----	9306123000	
46	Compressor Assy	9312161010	9310712016		942	Control Box Cover Metal	9306476007	-----	
48	Fan Ring	9306019013	-----		942-1	Control Box Cover-A Metal	-----	9308562012	
51	Special Nut M5	9312163007	9307091001		942-2	Control Box Cover-B Metal	9305975006	9305975006	
								-----	
55	Special Nut M6	9307615016	313252257701		946	Inlet Pipe	-----	9306401009	
62	Wire Assy (Shield)-A	9305791026	9305971026		982	Cord Clamp, Plastic	9302271002	9302271002	
98	Fan Ring	-----	9305581023		985	Special Nut w/Washer	9304902003	9304902003	
107	Rubber Seat-A	-----	9307092008		986	Special Washer	9304903000	9304903000	
109	Terminal Cover	9302419008	9307090004		A	Screw (with Inner Washer)	-----	9357297002	
138	Separate Wall Metal	9306474003	9305971008		B	Screw (with Spring Washer)	-----	0700179013	
187	Clamp No.1219	-----	313361271706			BR Sheet 30x120x T7	-----	9310825020	
195	Clamp SKB-100	313361275805	313361275805			BR Sheet 180x180x T2	-----	9310825037	
196	Clamp SKB-150	-----	313035356905			BR Sheet 100x160x T5	-----	9310825044	
196-2	Clamp SKB-3MC	9305335008	9305335008			BR Sheet 50x190x T3	-----	9304381037	
								-----	
230	Overload Relay	9307750007	9352453007			BR Sheet 30x120x T5	9305039272	-----	
329	Coupling Pipe Assy	-----	9306400002			BR Sheet 50x160x T5	9305039227	-----	
329-2	Coupling Pipe-C	-----	9306433000			BR Sheet 30x150x T2	9305039128	-----	
343	Solenoid Coil	9970003011	9970003011			BR Sheet 20x120x T5	9305039104	-----	
344	4-Way Valve	9970010019	9970010019			BR Sheet 180x180x T2	9305039067	-----	
365	Bracket (Valve)	9306020026	9306748012						

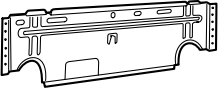

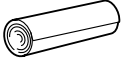
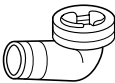

## STANDARD ACCESSORIES

Name and Shape	Part No.	
	ASH9RSJCW	ASH12RSJCW
Wall hook bracket 	9304358008	9304358008
Remote control unit 	9312058020	9312058020
Battery (penlight) 	0600185534	0600185534
Tapping screw (Ø4 x 25 ) 	0700076046	0700076046
Cloth tape 	9308117007	9308117007
Drain pipe (Including drain packing) 	9303029015	9303029015
Seal A 	-----	9304536000