



MULTI AIR CONDITIONER WALL MOUNTED type

SERVICE MANUAL



Models

Indoor unit

Outdoor unit

ASH9FMBD

AOH19FSCV2

CONTENTS

SPECIFICATIONS	1
OUTLINE AND DIMENSIONS	2
REFRIGERANT SYSTEM DIAGRAM	4
CIRCUIT DIAGRAM	5
INDOOR PCB CIRCUIT DIAGRAM	6
ERROR CONTENTS	7
DISASSEMBLY ILLUSTRATION	8
PARTS LIST	15
STANDARD ACCESSORIES	17

SPECIFICATIONS

ELECTRICAL DATA

TYPE	COOL	
INDOOR UNIT	ASH9FMBD	ASH9FMBD x 2
OUTDOOR UNIT	AOH19FSCV2	
COOLING CAPACITY	2.85 kW	5.70 kW
POWER SOURCE	230 V	
FREQUENCY	50 Hz	
RUNNING CURRENT	4.6 A	8.6 A
INPUT WATTS	1.02 kW	1.89 kW
E.E.R.	2.79 kW/kW	3.02 kW/kW
MOISTURE REMOVAL	1.0 L/hr	2.0 L/hr
AIR CIRCULATION-High	520 m3/hr	520 m3/hr x 2

INDOOR UNIT

FAN MOTOR	HIGH-SPEED	1,310 r.p.m.
	MED-SPEED	1,190 r.p.m.
	LOW-SPEED	1,070 r.p.m.
	QUIET	960 r.p.m.
DIMENSIONS	H x W x D	257 x 808 x 187 mm
WEIGHT	GROSS / NET	10 kg / 8 kg
NOISE LEVEL	HIGH-SPEED	40 dB
	MED-SPEED	37 dB
	LOW-SPEED	34 dB
	QUIET	31 dB

OUTDOOR UNIT

COMPRESSOR TYPE	Hermetic type, Permanent split condenser, 2 pole, Single phase, Induction motor, Rotary	
COMPRESSOR DISCRIMINATION	802 141 65B	
POWER SOURCE	230V - 50Hz	
REFRIGERANT	R410A	700 g x 2
ADDITIONAL CHARGE	10 g/m	
CHARGELESS PIPE LENGTH	7.5 m	
MAXIMUM PIPE LENGTH	15 m	
FAN MOTOR	780 r.p.m.	
DIMENSIONS	H x W x D	700 x 900 x 330 mm
WEIGHT	Gross / Net	68 kg / 61 kg
NOISE LEVEL	52 dB	

OUTLINE AND DIMENSIONS

INDOOR UNIT
Model : ASH9FMBD
(Unit : mm)

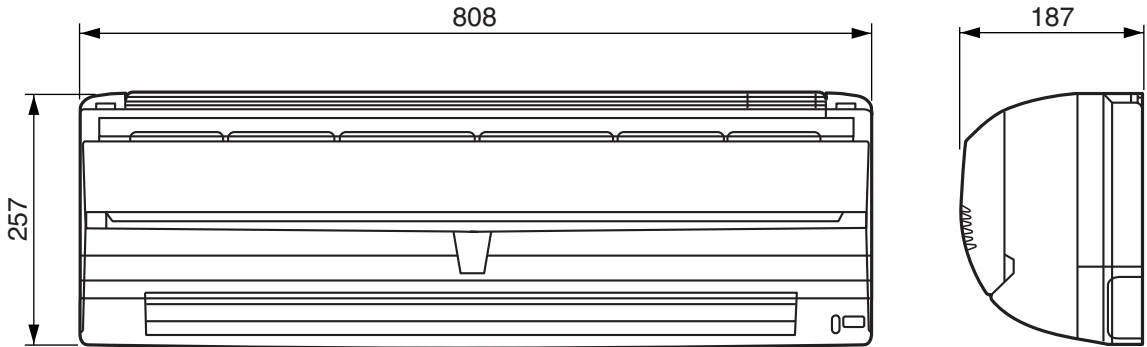

OUTDOOR UNIT
Model : AOH19FSCV2
(Unit : mm)

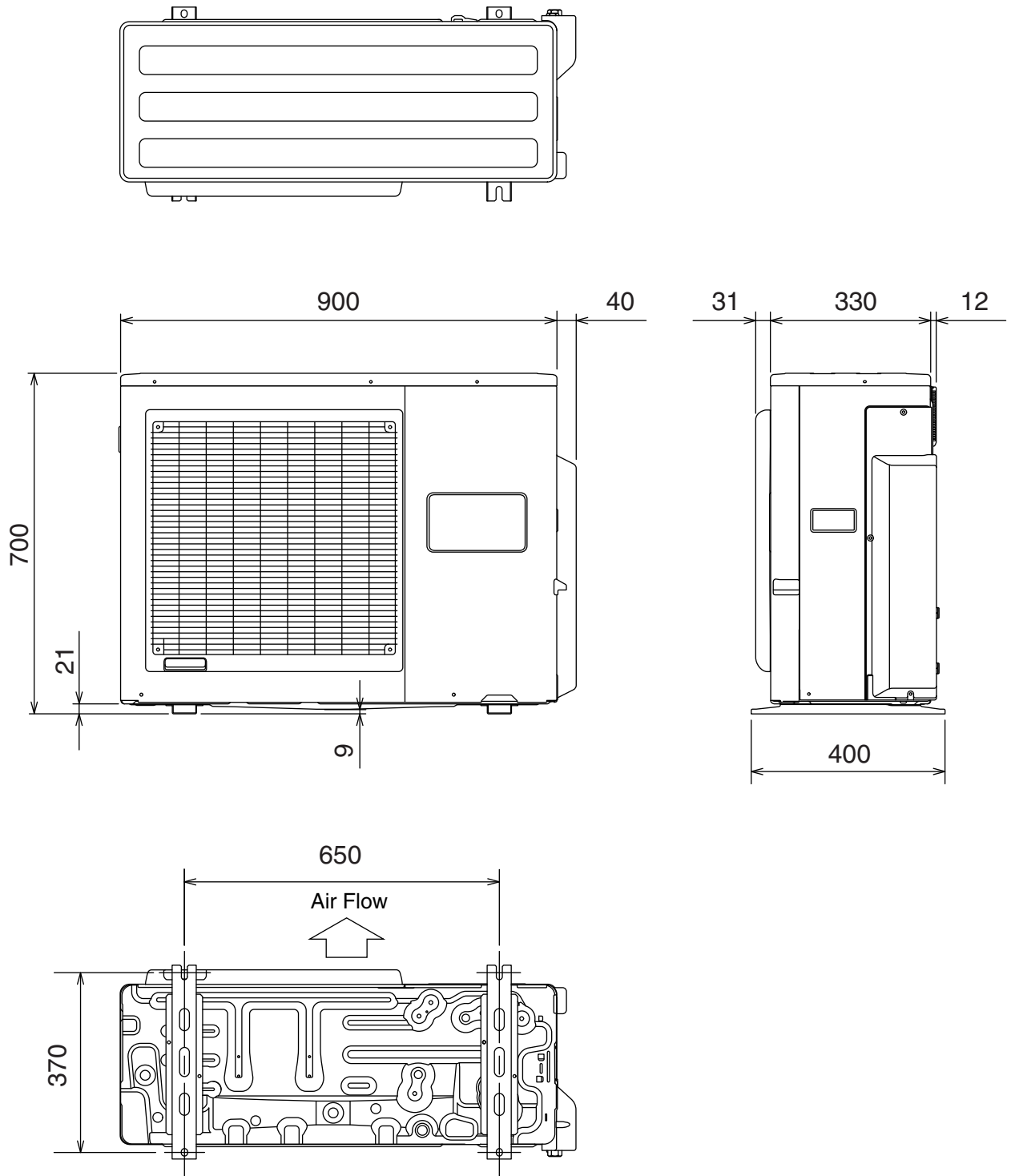

REFRIGERANT SYSTEM DIAGRAM

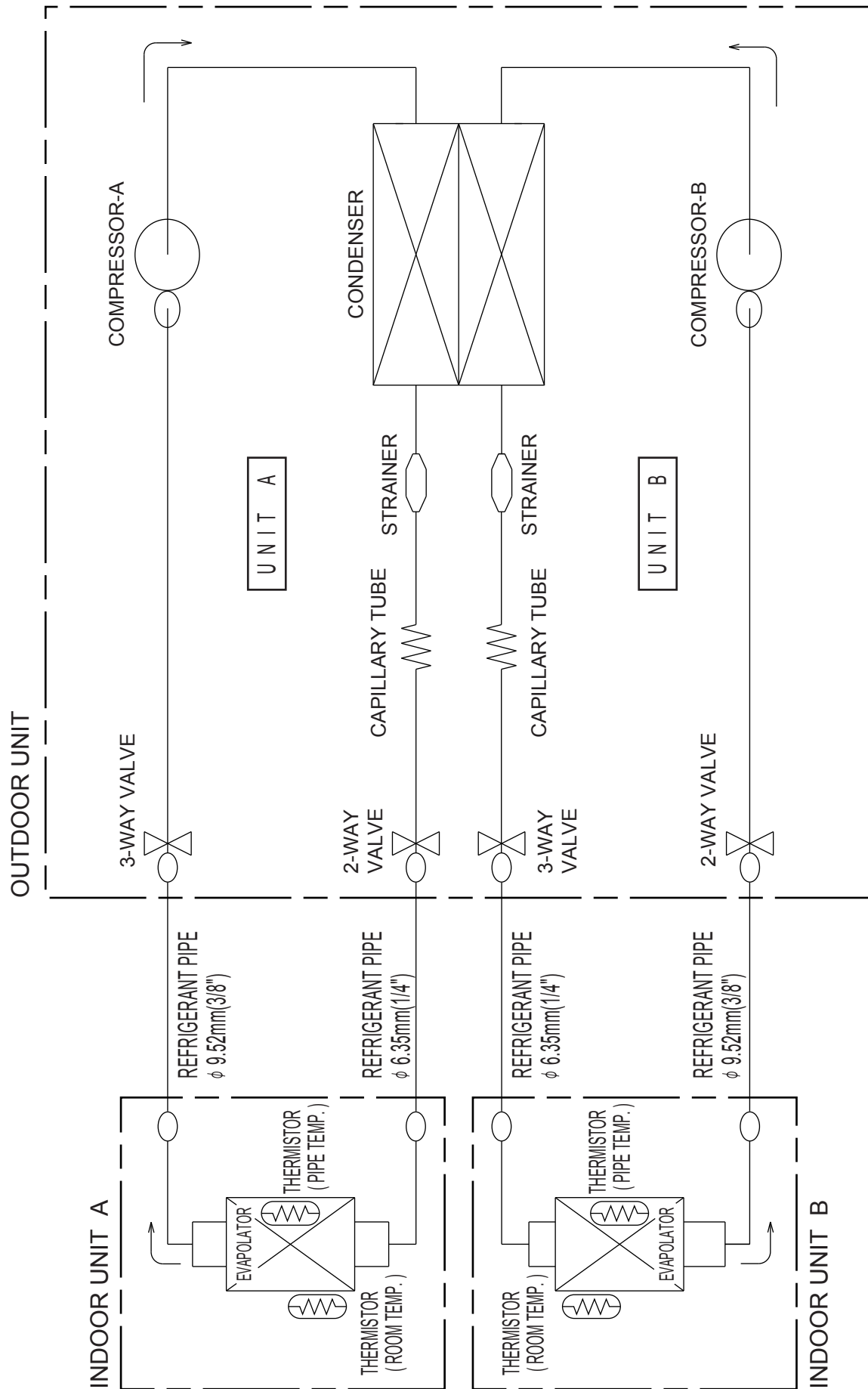

CIRCUIT DIAGRAM

Models : ASH9FMBD / AOH19FSCV2

INDOOR UNIT

OUTDOOR UNIT

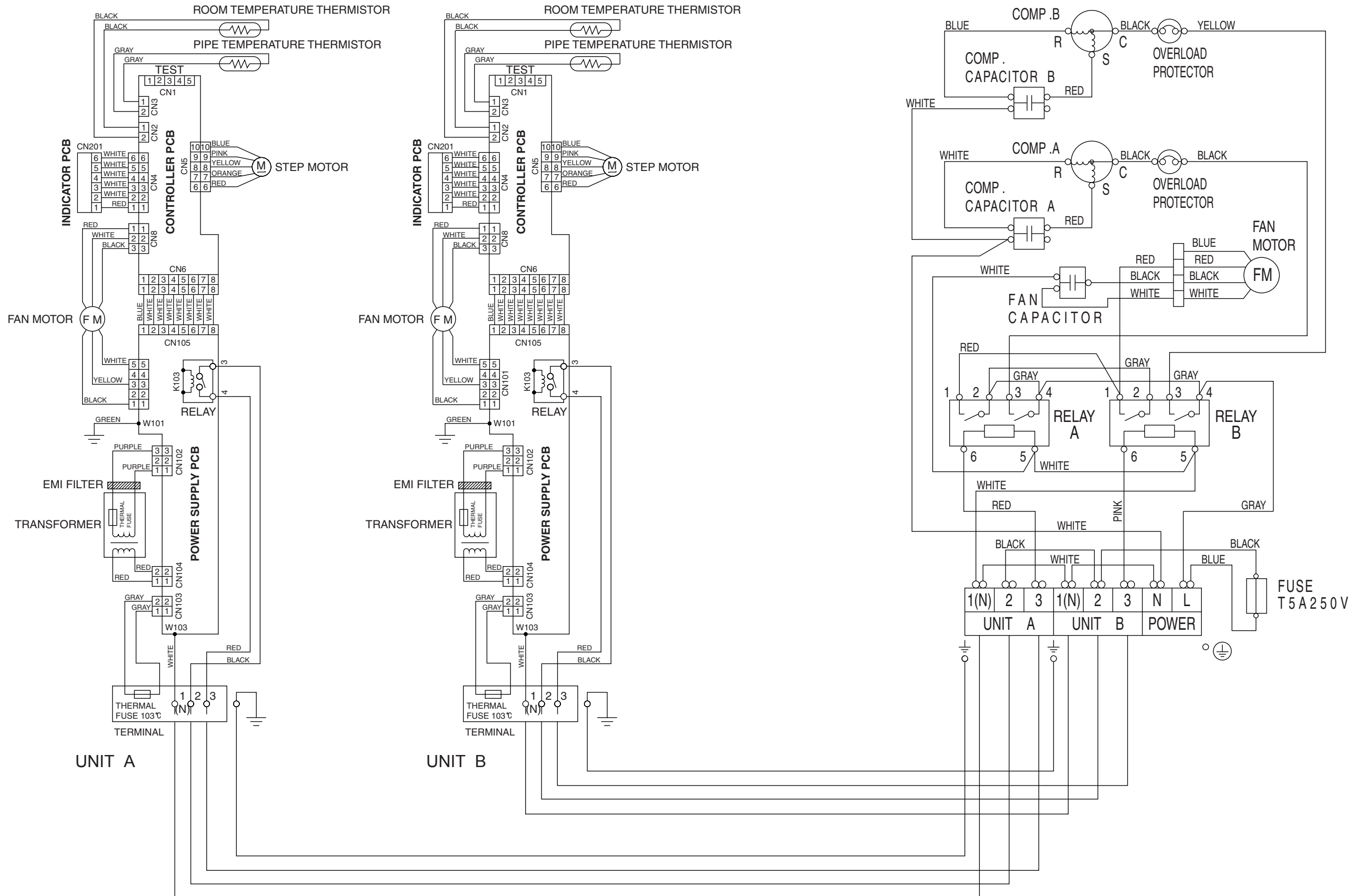

INDOOR PCB CIRCUIT DIAGRAM

Model : ASH9FMBD

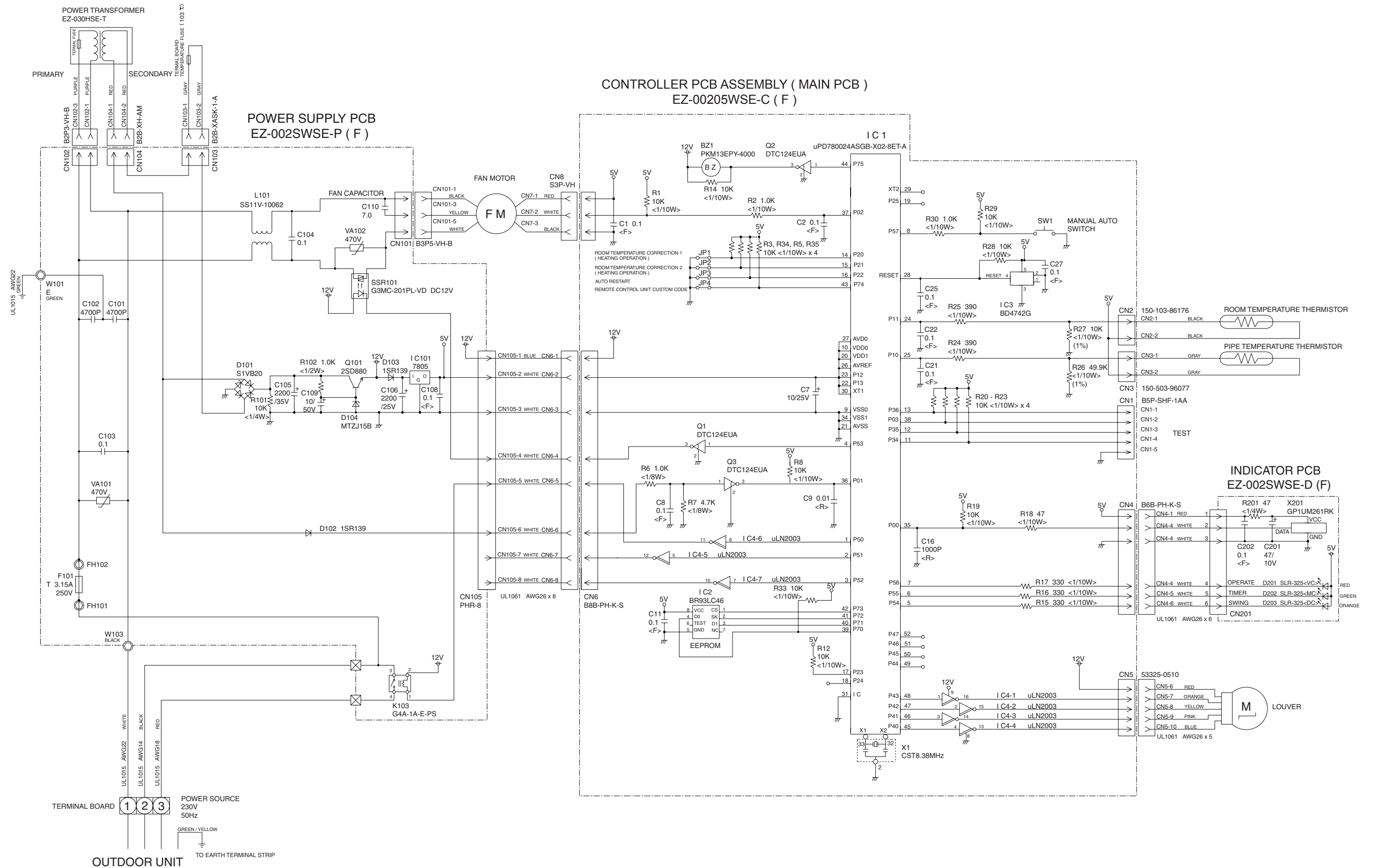

ERROR CONTENTS

INDOOR UNIT

○ : Fast flashing ● : Slow flashing

Operation lamp : Red lamp

Timer lamp : Green lamp

Large division indication			Small division indication		
Error contents	LED indication		Error contents	LED indication	
circuit board error (indoor unit)	Red lamp Green lamp	○ ○	-----	-----	-----
thermistor error	Red lamp Green lamp	● (2 times) ○	thermistor error (room temp.)	Red lamp	○
			thermistor error (heat exchanger)	Red lamp Green lamp	○ ● (3 times)
control unit error (indoor unit)	Red lamp Green lamp	● (4 times) ○	MANUAL AUTO button error	Red lamp	○
			power source Hz decision error	Red lamp Green lamp	○ ● (4 times)
fan motor error (indoor unit)	Red lamp Green lamp	● (6 times) ○	lock error	Red lamp	○
			r.p.m error	Red lamp Green lamp	○ ● (3 times)

When an error occurs, "Large division indication" is indicated first.

Secondly, "Small division indication" is indicated by pushing "Test" button of remote controller.

DISASSEMBLY ILLUSTRATION

Model : ASH9FMBD

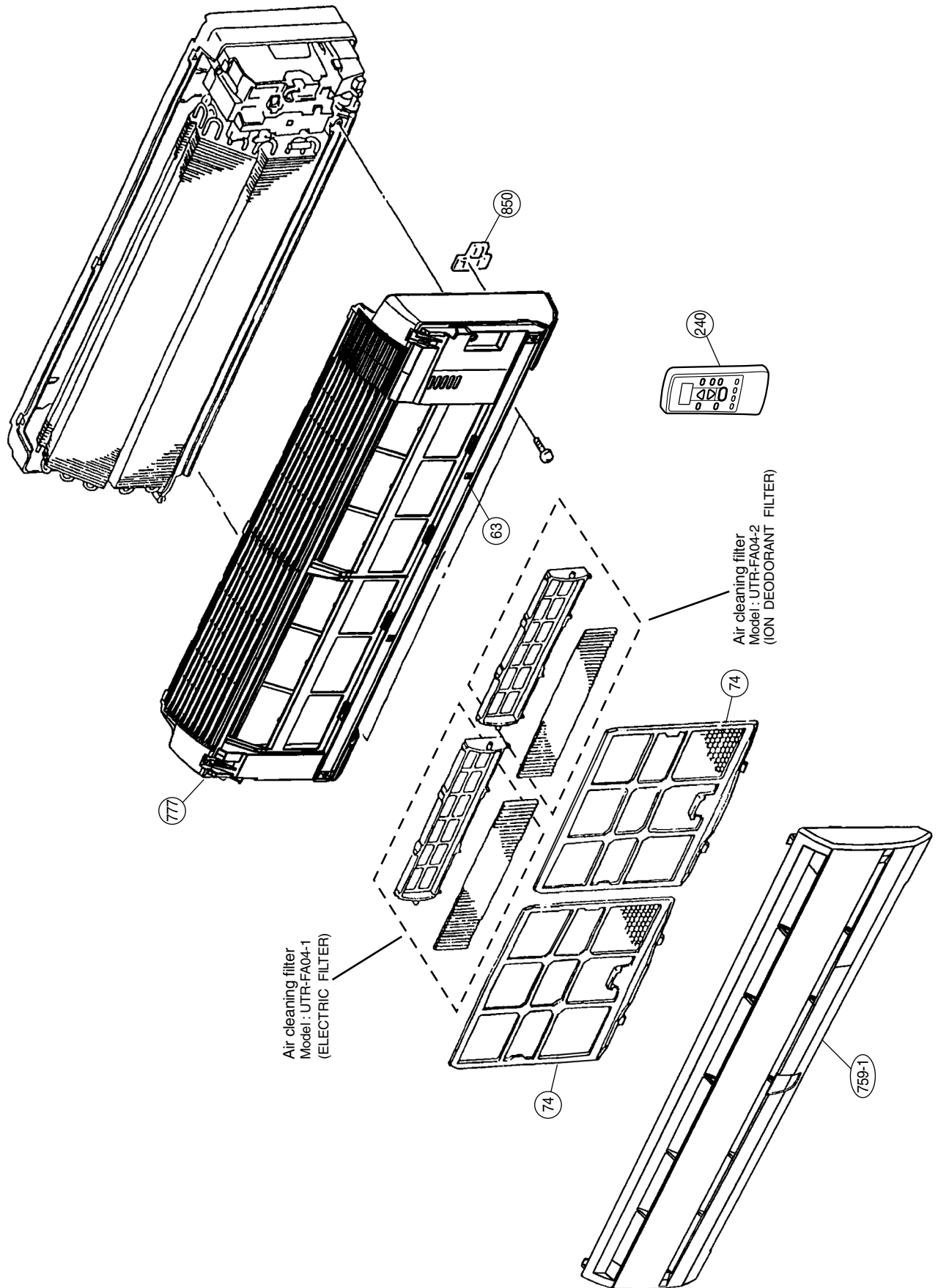

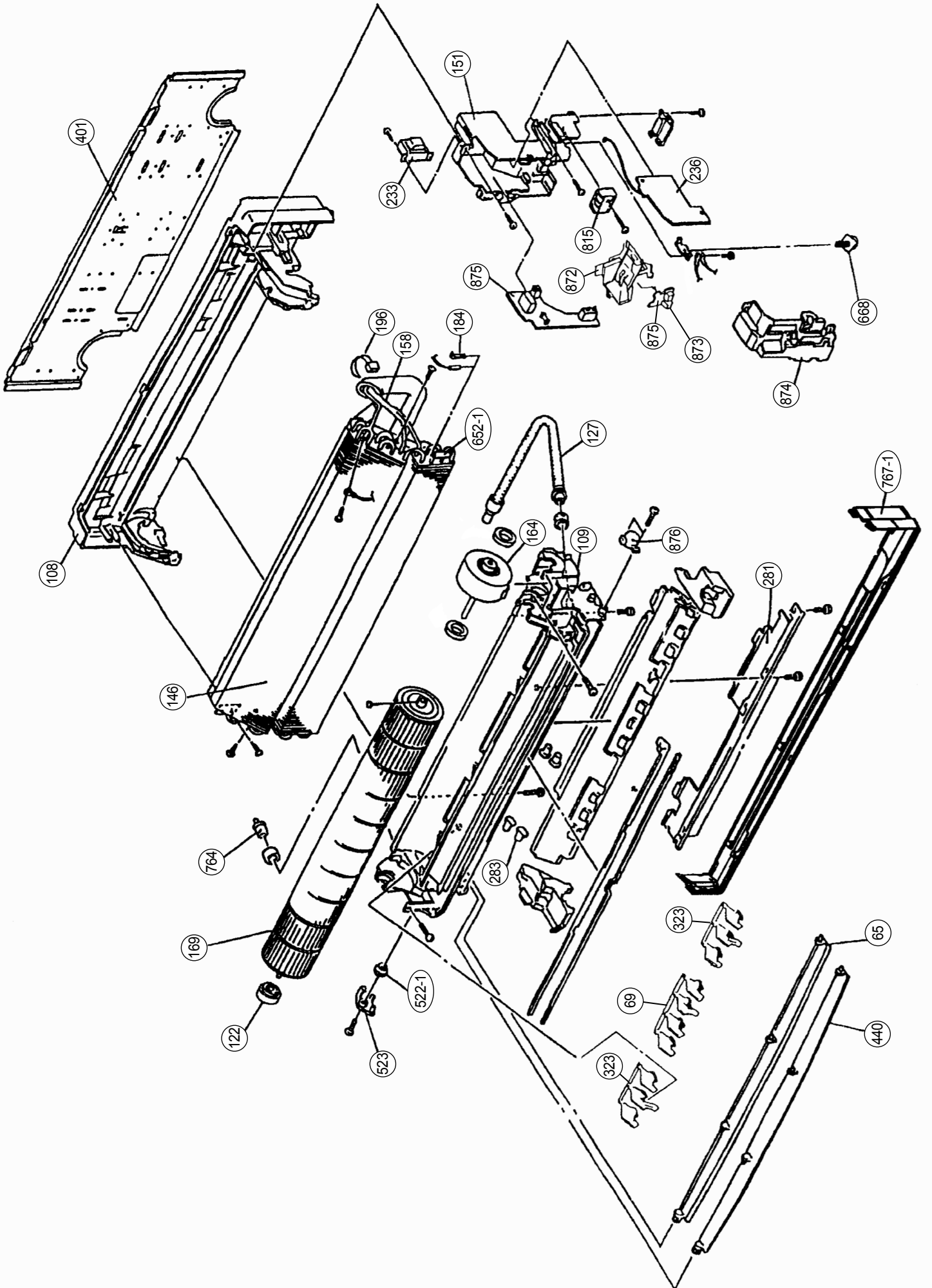

Model : AOH19FSCV2

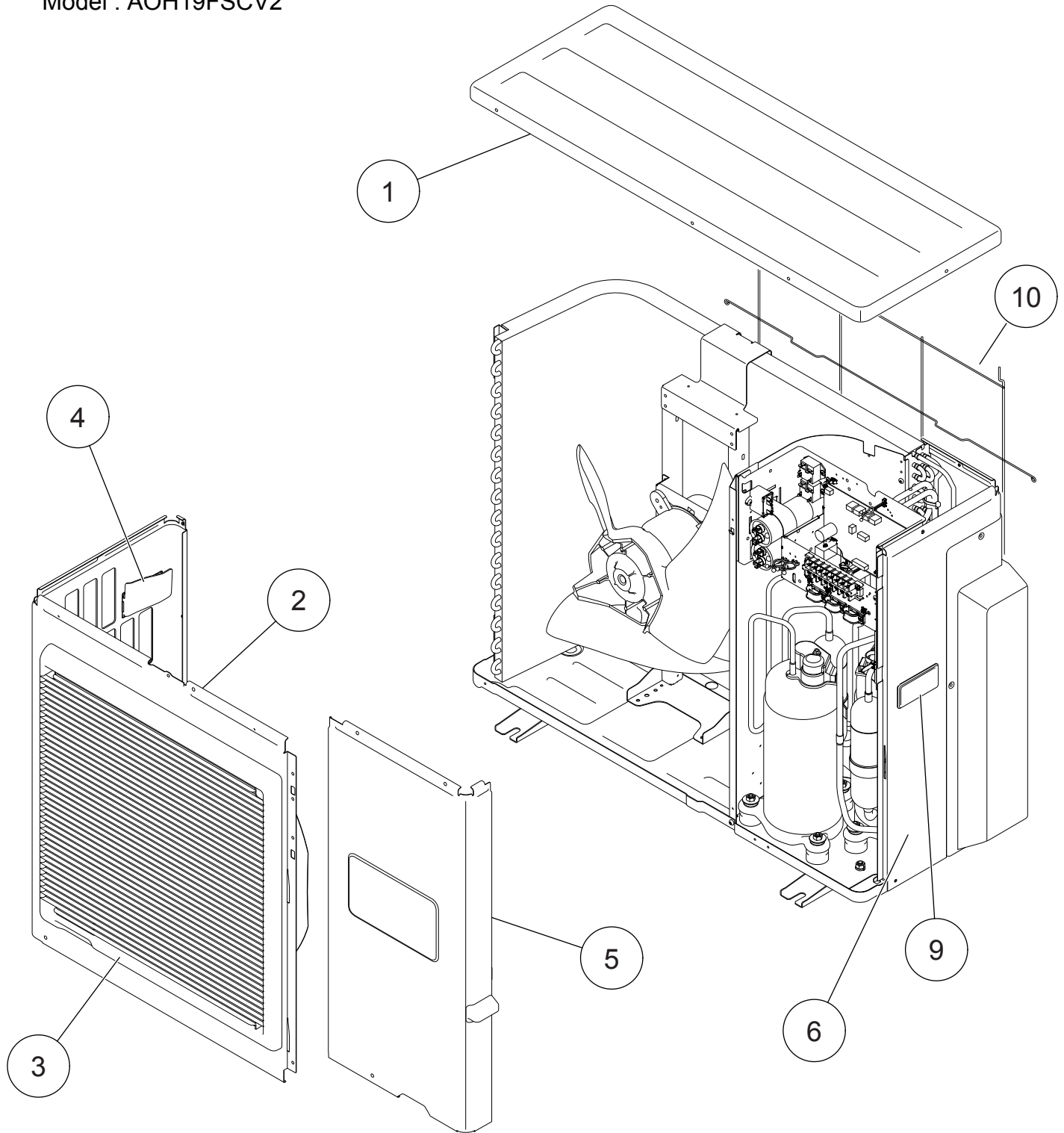

Model : AOH19FSCV2

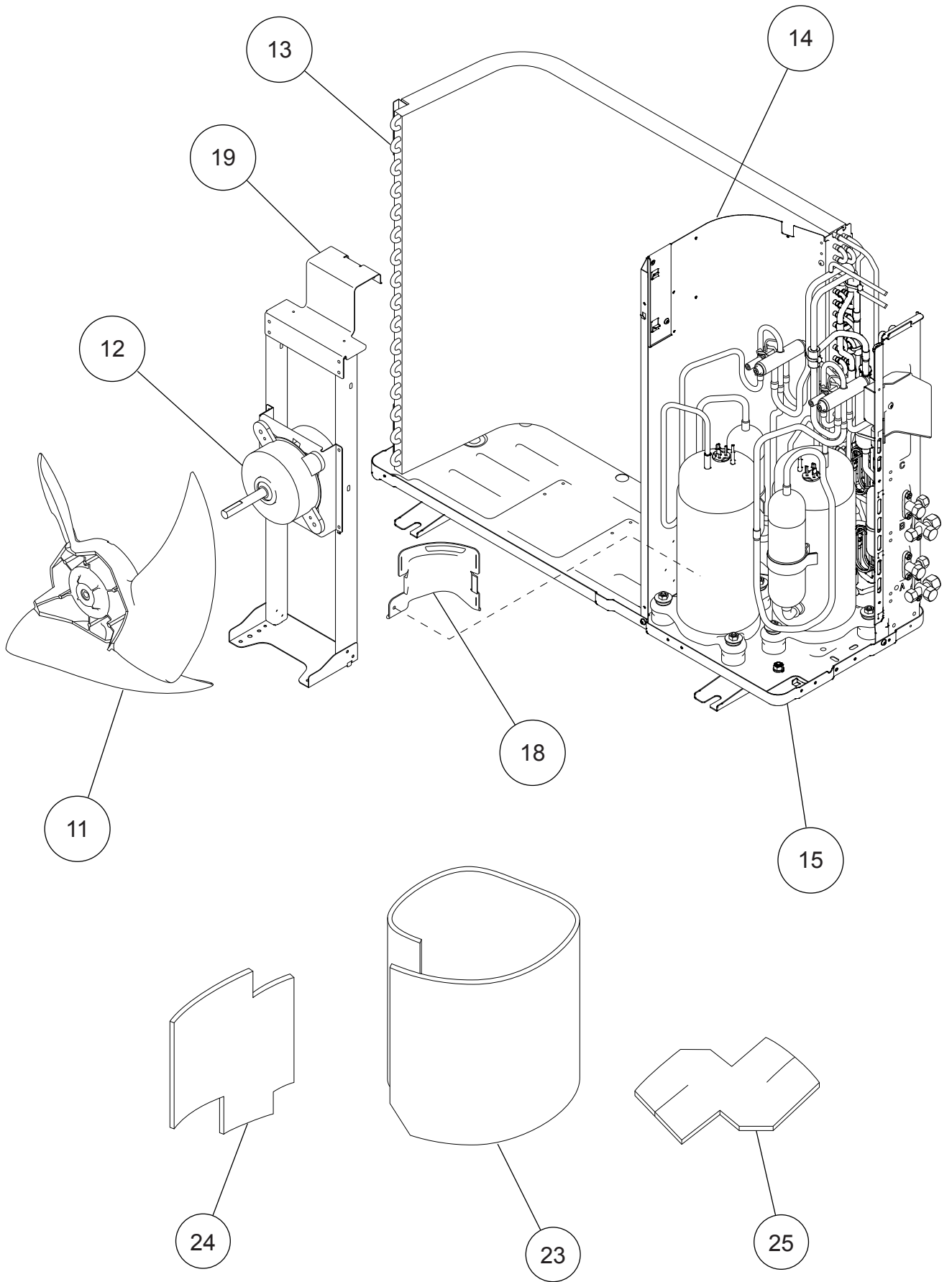

Model : AOH19FSCV2

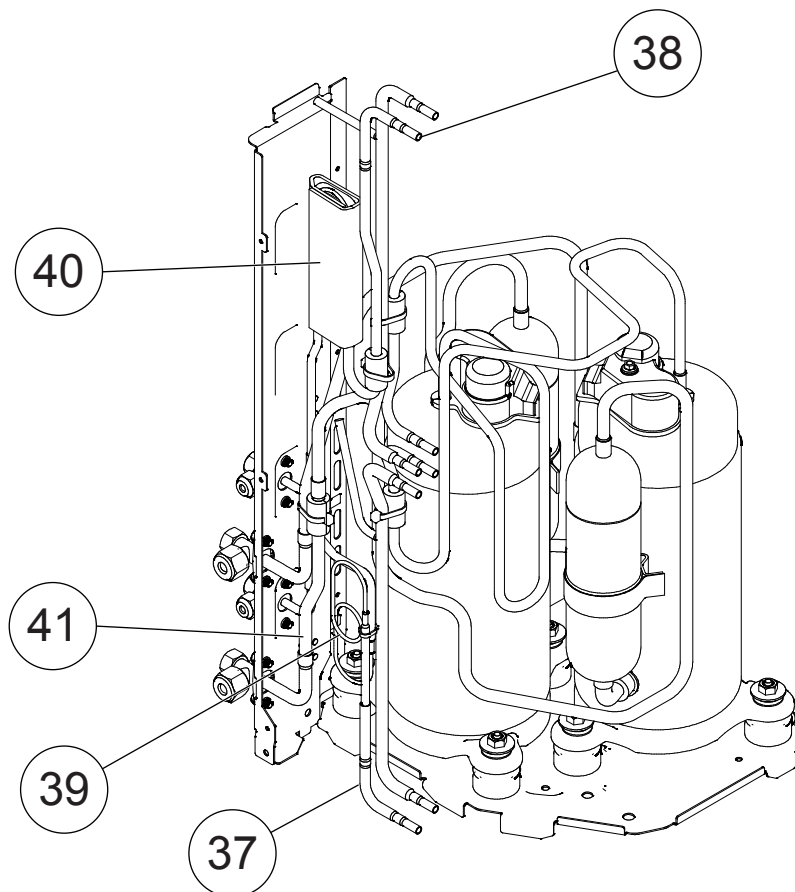
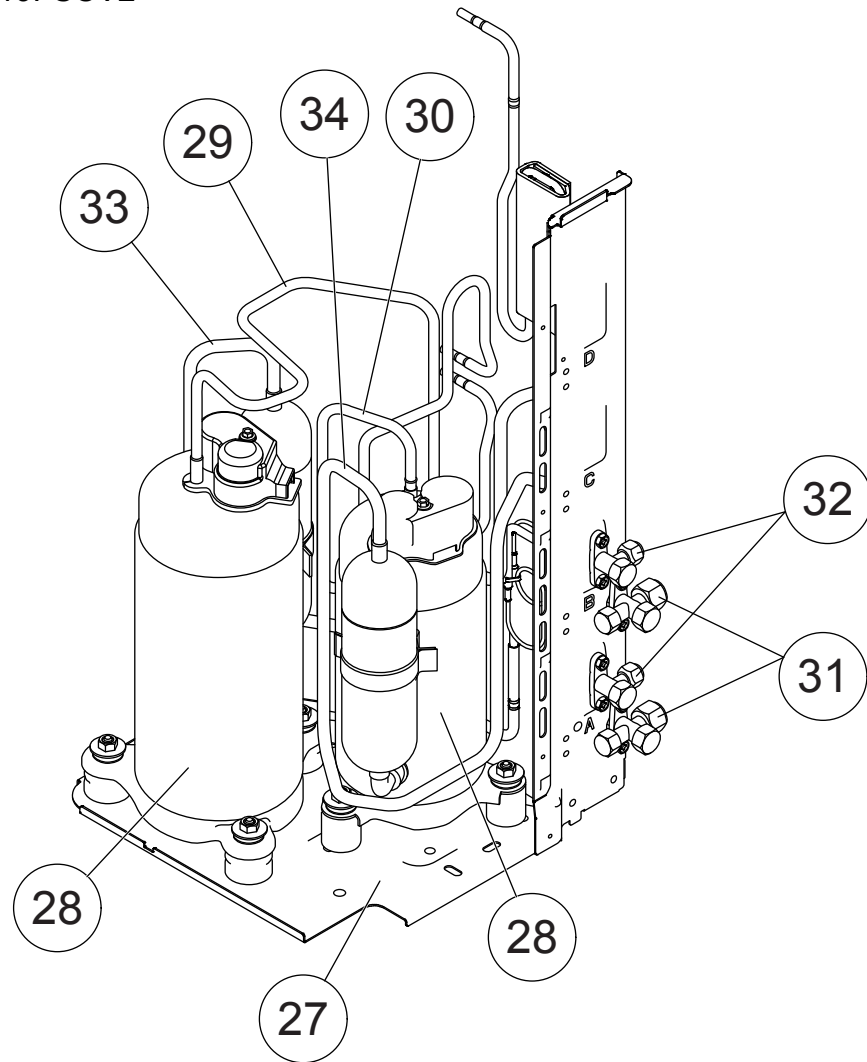

Model : AOH19FSCV2

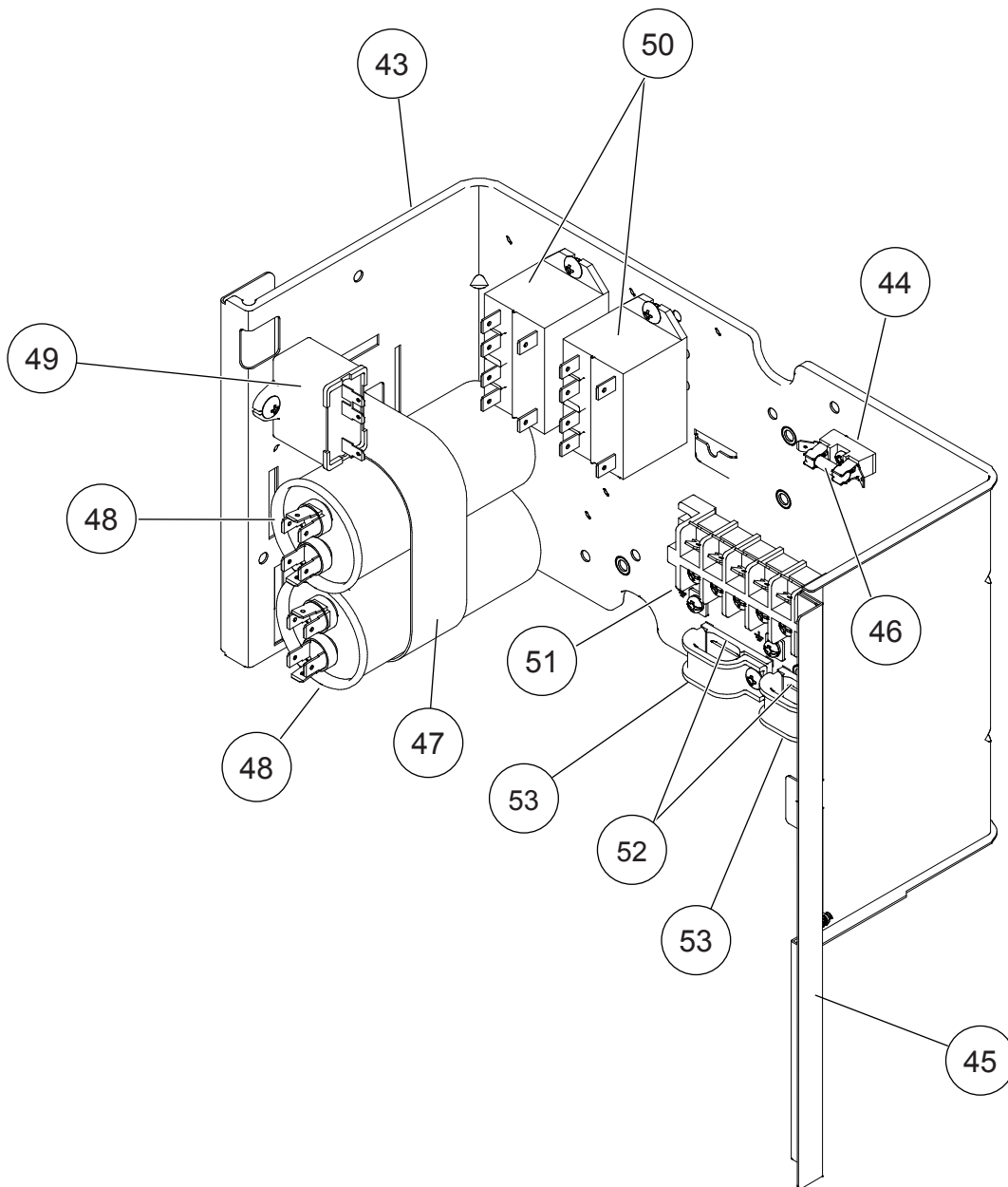

Model : AOH19FSCV2

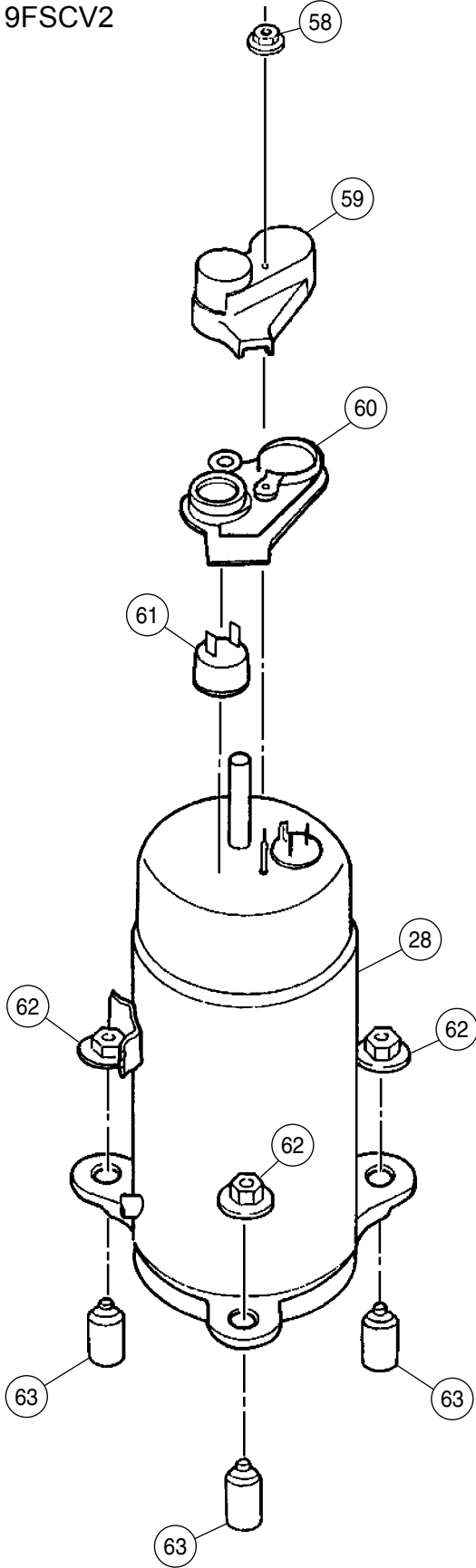

PARTS LIST

INDOOR UNIT





Ref. No.	Description	Part No.	Ord. Q'ty
		ASH9FMBD	
63	Front Panel Assy	9312172085	
65	Flow Control Panel-Z	9306058043	
69	Louver-A	9306055028	
74	Filter	9305444014	
108	Base	9309755062	
109	Casing	9306052027	
122	Shaft Holder-B	9303066010	
127	Drain Hose Assy	9305550029	
146	Evaporator Assy	9373044017	
151	Control Box	9330007017	
158	Connecting Pipe Assy	9306416010	
164	Fan Motor Assy-IN	9601844013	
169	Cross-Flow Fan Assy	9307836015	
184	Thermistor Spring	313728262708	
196	Clamp SKB-150	313035356905	
233	Power Transformer	9701803026	
236	Controller PCB Assy (EZ-00205WSE-C)	9704865045	
240	Remote Control Unit	9312058037	
281	BRACKET(PIPE)	9330011014	
283	Bushing-A	9303529010	
323	Louver-B	9306056025	
401	Wall Hook Bracket	9304358008	
440	Flow Control Panel-U	9306057046	
522-1	Gear-A	9306062002	
523	Gear Bracket	9306407001	
652-1	Thermistor Holder Pipe	313714262805	
668	Screw w/Washer	9372808023	
759-1	Intake Grille	9330002012	
764	Drain Cap Assy	9304150008	
767-1	Bottom Cover	9330004016	
777	CLAMPER(GRILL)	9306755010	
815	Terminal	9900040055	
850	Window (Receiver)	9330003019	
872	Indicator Case	9330009011	
873	Lamp Cover	9330014015	
874	Control Box Cover	9330008014	
875	PCB Assy (Power+Indicator)	9704871053	
876	Step Motor	9900139018	

OUTDOOR UNIT

Ref. No.	Description	Part No.	Ord. Q'ty
		AOH19FSCV2	
1	Top Panel Sub Assy	9374417018	
2	Front Panel S	9374094080	
3	Fan Guard	9374330010	
4	Grip Side	9374173013	
5	Service Panel Sub Assy	9374415045	
6	Right Panmel	9374599042	
9	Grip	9374172016	
10	Print Net S	9374255047	
11	Propeller Fan Assy	9366378013	
12	Motor, Induction	9601671060	
13	Condenser A Assy	9374433100	
14	Separate Wall S	9374135042	
15	Base Assy	9374166121	
18	Cap Foot	9374345014	
19	Motor Bracket Sub Assy	9374418084	
23	Compressor Cover A	9375323028	
24	Compressor Cover B	9374431076	
25	Compressor Cover C	9372067055	
27	Compressor Plate Assy	9375221010	
28	Compressor Assy	9373010029	
29	Discharge Pipe A1	9372179420	
30	Discharge Pipe B1	9372180334	
31	3-Way Valve Assy	9375103019	
32	2-Way Valve Assy	9375102012	
33	Suction Pipe A1	9372176351	
34	Suction Pipe B1	9371275253	
37	Condensing Pipe A1	9372232088	
38	Condensing Pipe B1	9372231111	
39	Capillary A Assy	9375297046	
40	Capillary B Assy	9375298050	
41	Joint Pipe (Valve) A1	9372178164	
43	Control Box A	9375216016	
44	Fuse Holder	0501456016	
45	Control Box D	9375219017	
46	Fuse	0600376086	
47	Band (Capacitor)	9352123009	
48	Capacitor, Plastic (Comp.)	9900269043	
49	Capcitor, Plastic (Fan)	9900270049	
50	Relay	9900239015	
51	Terminal	9900203047	
52	Clamp (Cord) C	9359677000	
53	Clamp (Cord)	9356857009	
58	Special Nut M5	313199233602	
59	Terminal Cover (Comp.)	9302419008	
60	Terminal Gasket (Comp.)	9351505011	
61	OCR Assy	9311143000	
62	Special Nut	9355091008	
63	Rubber Seat (Comp) A	9351507015	
---	Emblem Rear	9372171011	

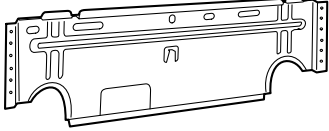
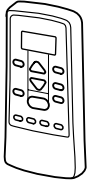
STANDARD ACCESSORIES

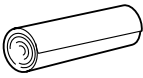
INDOOR UNIT

Name and Shape	Q'ty	Part No.
Wall hook bracket 	1	9304358008
Remote control unit 	1	9312058037 (AR-JE06)
Battery (penlight) 	1 set	0600185534
Remote control unit holder case 	1	9312653010
Cloth tape 	1	9310519004
Tapping screw (big) ($\phi 4 \times 25$) 	8	0700076046
Tapping screw (small) ($\phi 3 \times 12$) 	2	0700019036

OUTDOOR UNIT

Name and Shape	Q'ty	Part No.
Putty 	1	303020200114

0603G3042