



**HIGH POWER MULTI  
AIR CONDITIONER  
WALL MOUNTED type**

**SERVICE  
MANUAL**



**Models**

<b>Indoor unit</b>	<b>Outdoor unit</b>
ASH9FMAD	AOH19FSAB2
ASH9FMAD	AOH19FGBB2

*preliminary*

**CONTENTS**

SPECIFICATIONS..... 1  
 OUTLINE AND DIMENSIONS..... 2  
 REFRIGERANT SYSTEM DIAGRAM..... 3  
 ERROR DISPLAY..... 4  
 CIRCUIT DIAGRAM..... 5  
 INDOOR PRINTED CIRCUIT BOARD CIRCUIT DIAGRAM..... 6  
 DISASSEMBLY ILLUSTRATION..... 7  
 PARTS LIST..... 14

# SPECIFICATIONS

TYPE	COOL			
INDOOR UNIT	ASH9FMAD	ASH9FMAD x 2	ASH9FMAD	ASH9FMAD x 2
OUTDOOR UNIT	AOH19FSAB2	AOH19FSAB2	AOH19FGBB2	AOH19FGBB2
COOLING CAPACITY (kW)	2.75	5.50	2.75	5.50

## ELECTRICAL DATA

POWER SOURCE (V)	230	230	230	230
FREQUENCY (Hz)	50	50	50	50
RUNNING CURRENT (A)	4.7	8.8	4.7	8.8
INPUT WATTS (kW)	1.04	1.96	1.04	1.96
E.E.R. (kW/kW)	2.64	2.81	2.64	2.81
MOISTURE REMOVAL (ℓ/hr)	1.0	2.0	1.0	2.0
AIR CIRCULATION-Hi (m <sup>3</sup> /hr)	520	520 x 2	520	520 x 2

## COMPRESSOR

TYPE	Hermetic type, Permanent split condenser, 2 pole, Single phase, Induction motor, Rotary		
POWER SOURCE	230V - 50Hz		
DISCRIMINATION	802 141 65B	GK 120 PAB	
REFRIGERANT R410A (g)	750 x 2	780 x 2	

## FAN MOTOR

POWER SOURCE (V)	230	
INDOOR UNIT	HI-SPEED (r.p.m.)	1,310
	MED-SPEED (r.p.m.)	1,190
	LO-SPEED (r.p.m.)	1,070
	QUIET (r.p.m.)	960
OUTDOOR UNIT (r.p.m.)	710	

## DIMENSIONS

INDOOR UNIT	H x W x D (mm)	257 x 808 x 187
OUTDOOR UNIT	H x W x D (mm)	700 x 900 x 350

## WEIGHT

INDOOR UNIT	GROSS / NET (kg)	10 / 8	
OUTDOOR UNIT	GROSS / NET (kg)	69 / 62	71 / 64

# OUTLINE AND DIMENSIONS

## INDOOR UNIT

(Unit : mm)

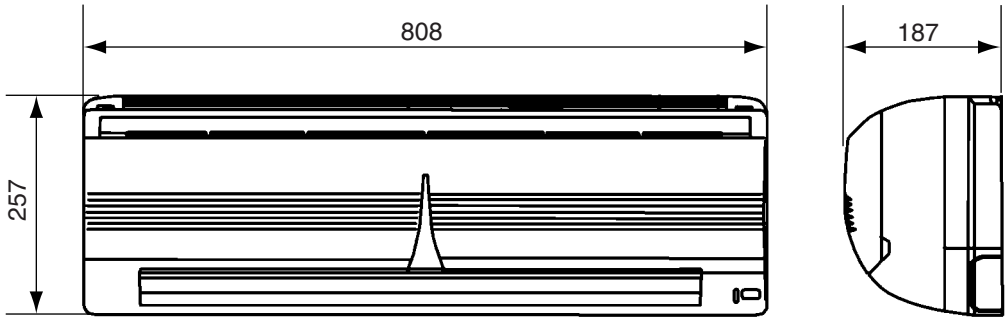

## OUTDOOR UNIT

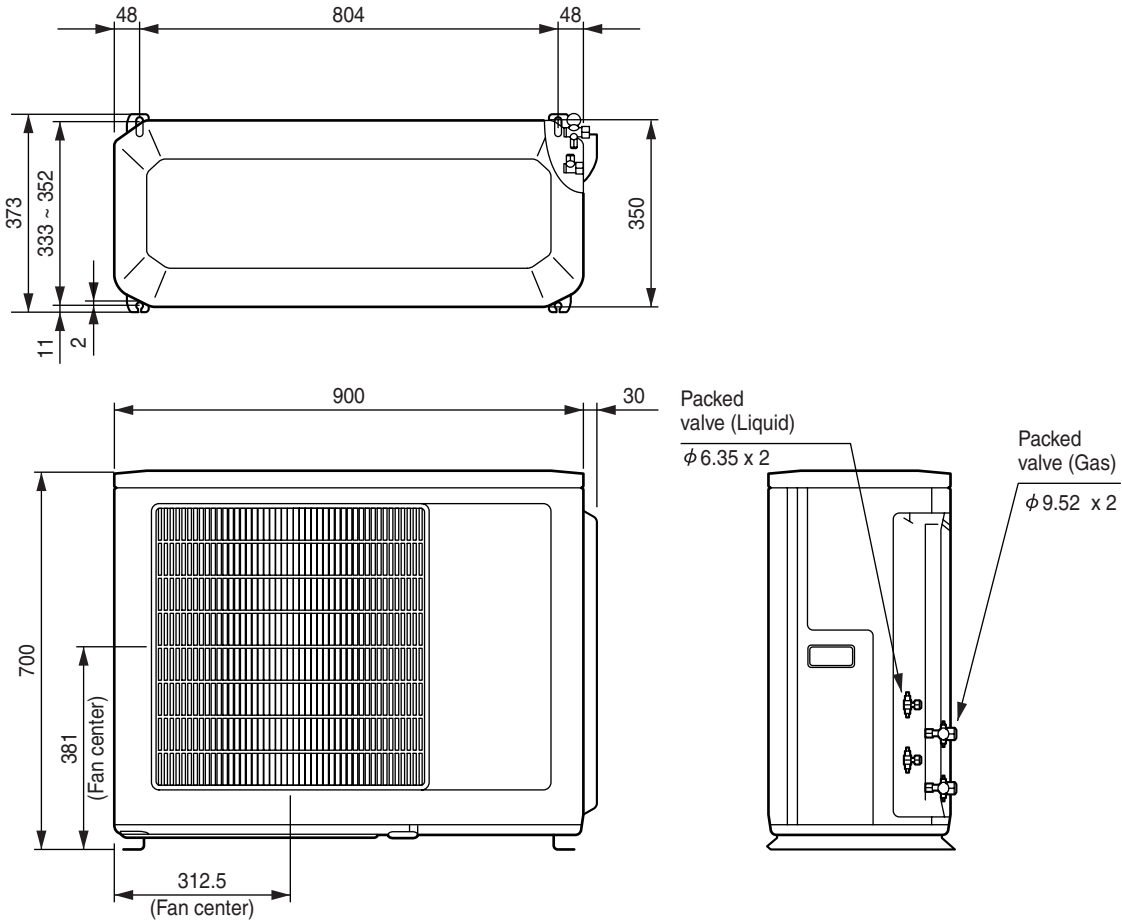

# REFRIGERANT SYSTEM DIAGRAM

Models : ASH9FMAD x 2 / AOH19FSAB2  
ASH9FMAD x 2 / AOH19FGBB2

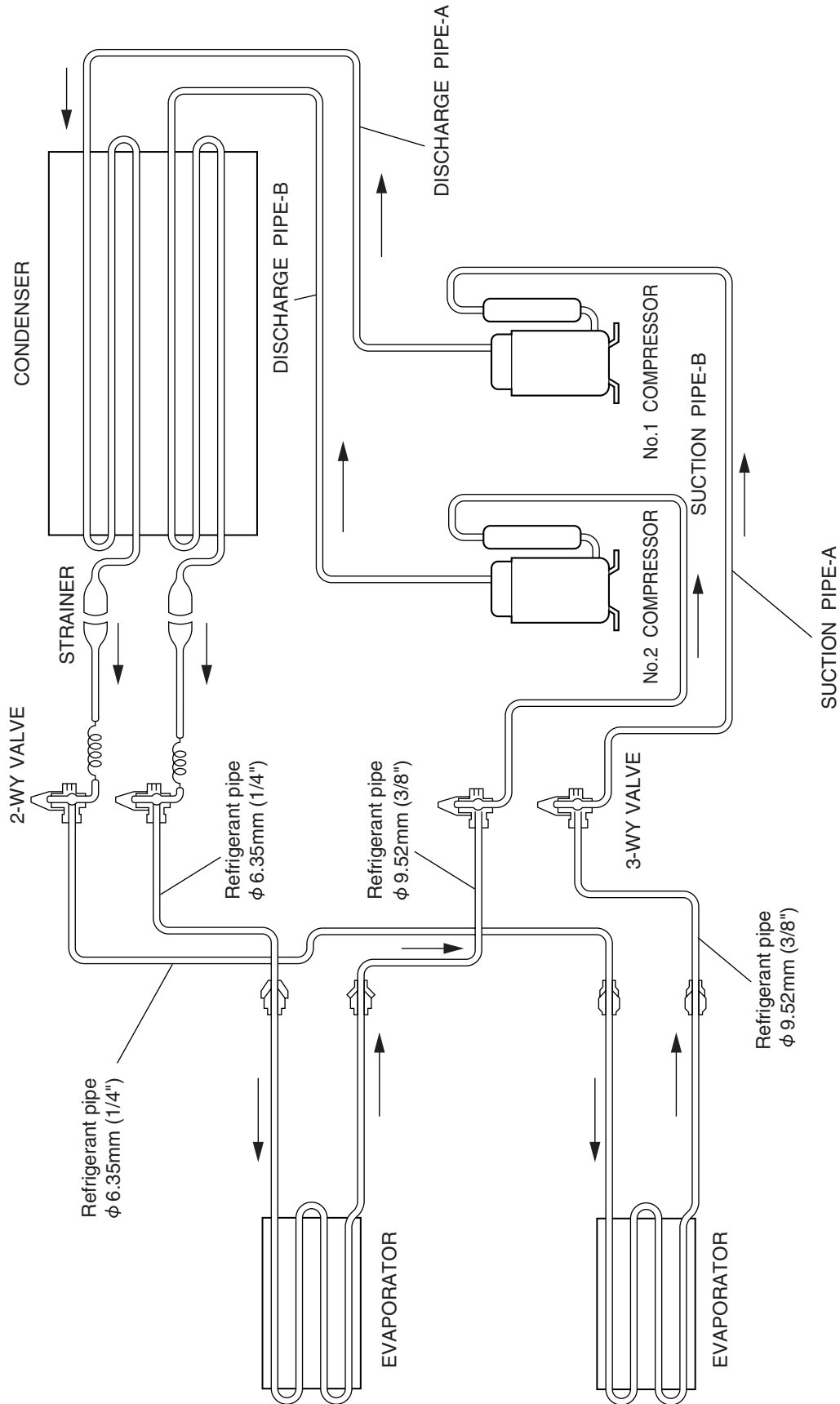

# ERROR DISPLAY

## INDOOR UNIT

○ : Fast flashing      ● : Slow flashing

Operation lamp : Red lamp

Timer lamp : Green lamp

Large division indication			Small division indication		
Error contents	LED indication		Error contents	LED indication	
thermistor error	Red lamp	● (2 times)	thermistor error (room temp.)	Red lamp	○
	Green lamp	○		Green lamp	● (2 times)
			thermistor error (heat exchanger)	Red lamp	○
				Green lamp	● (3 times)
control unit error (indoor unit)	Red lamp	● (4 times)	MANUAL AUTO button error	Red lamp	○
	Green lamp	○		Green lamp	● (2 times)
			power source Hz decision error	Red lamp	○
				Green lamp	● (4 times)
fan motor error (indoor unit)	Red lamp	● (6 times)	lock error	Red lamp	○
	Green lamp	○		Green lamp	● (2 times)
			r.p.m error	Red lamp	○
				Green lamp	● (3 times)

When an error occurs, "Large division indication" is indicated first.

Secondly, "Small division indication" is indicated by pushing "Test" button of remote controller.

# CIRCUIT DIAGRAM

Models : ASH9FMAD x 2 / AOH19FSAB2  
ASH9FMAD x 2 / AOH19FGBB2

## INDOOR UNIT

## OUTDOOR UNIT

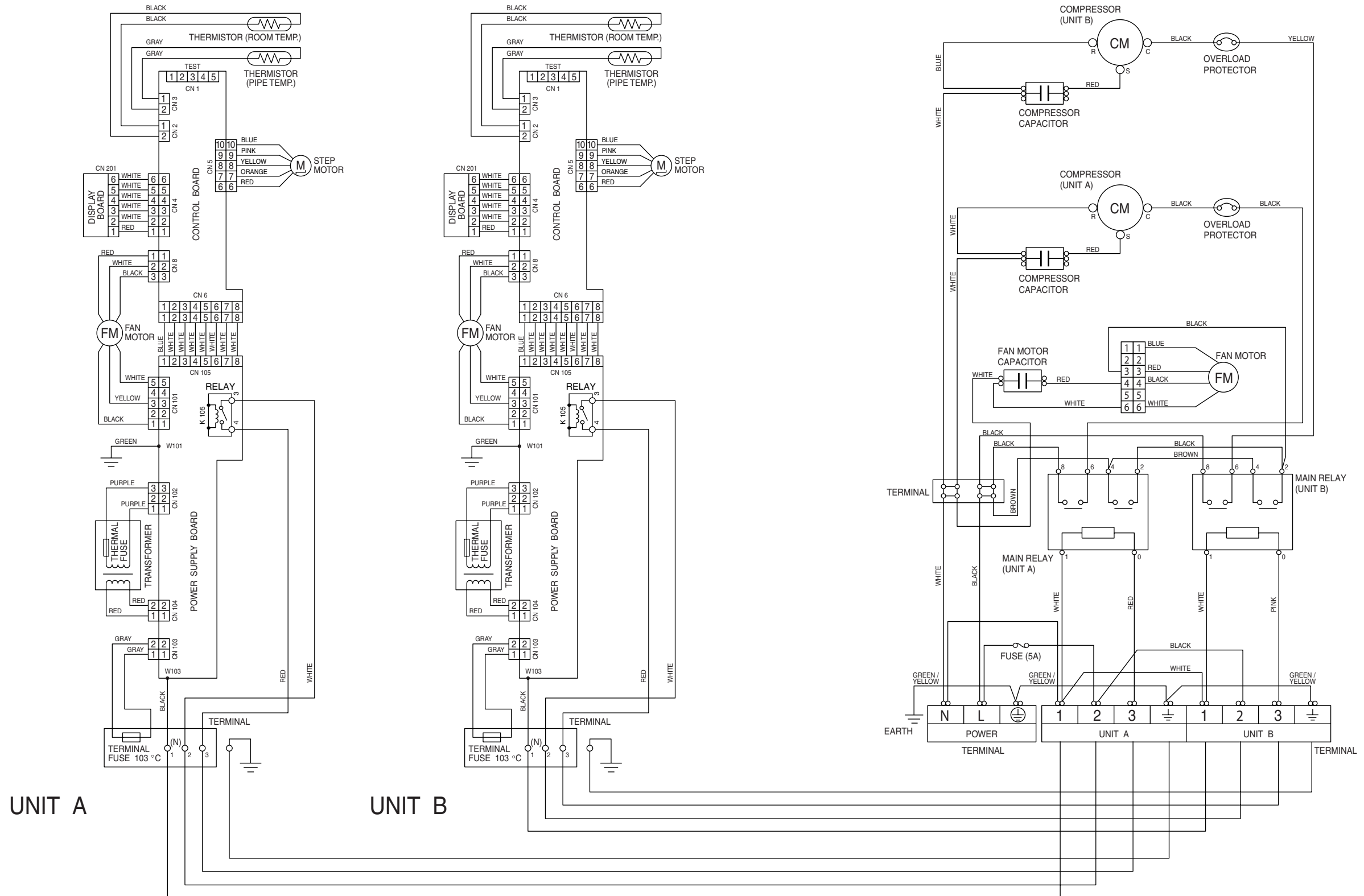

# INDOOR PCB CIRCUIT DIAGRAM

Model : ASH9FMAD

## Jumper wire configurations

Switch	Function	ON / Linked	OFF / Open
JM1	Heating compensation	+4	0
JM2	Cooling compensation	0	-2
JM3	Auto restart	enable	disable
JM4	Custom code	A	B

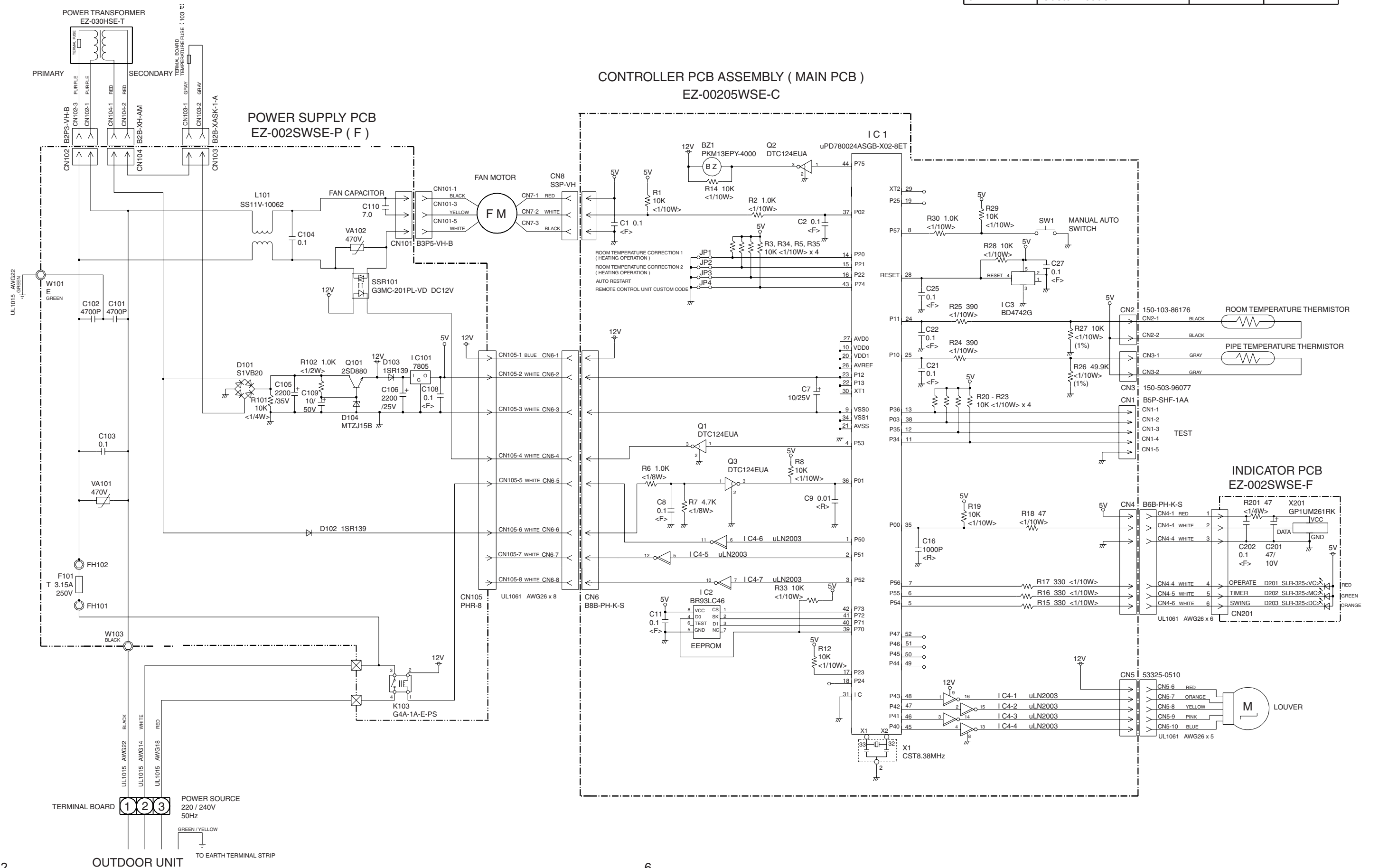

# DISASSEMBLY ILLUSTRATION

Model : ASH9FMAD

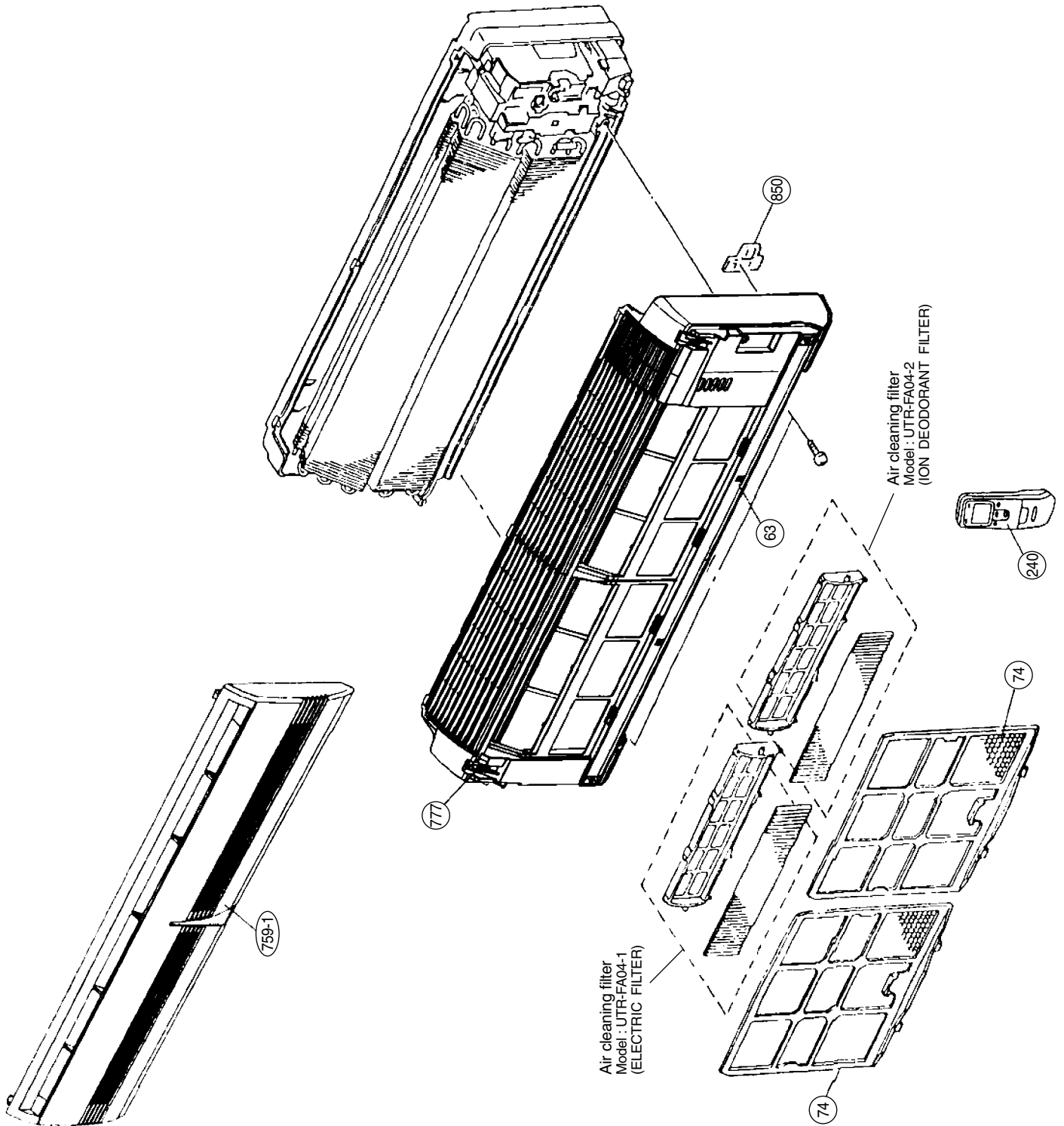



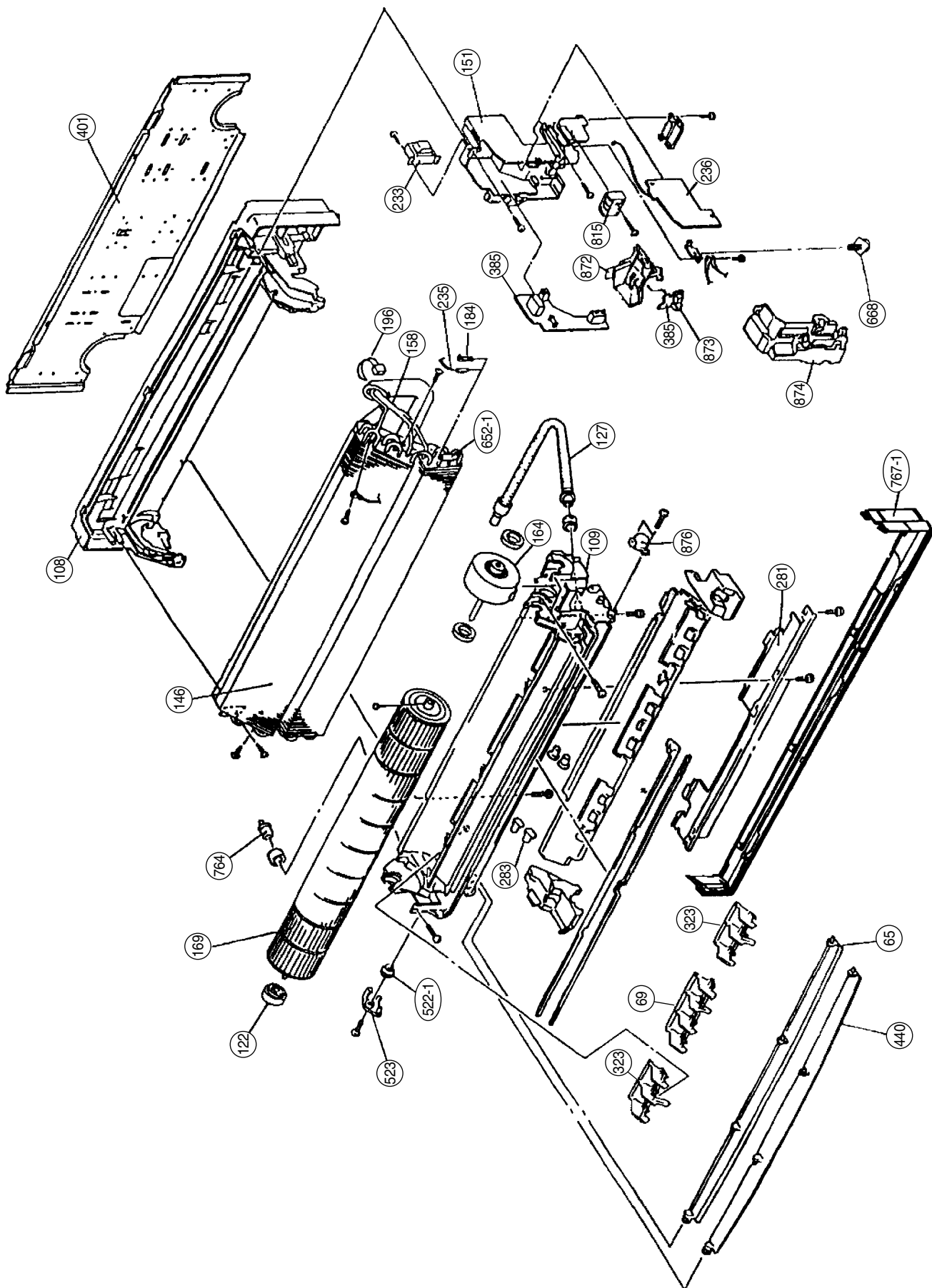

Model : AOH19FSAB2  
AOH19FGBB2

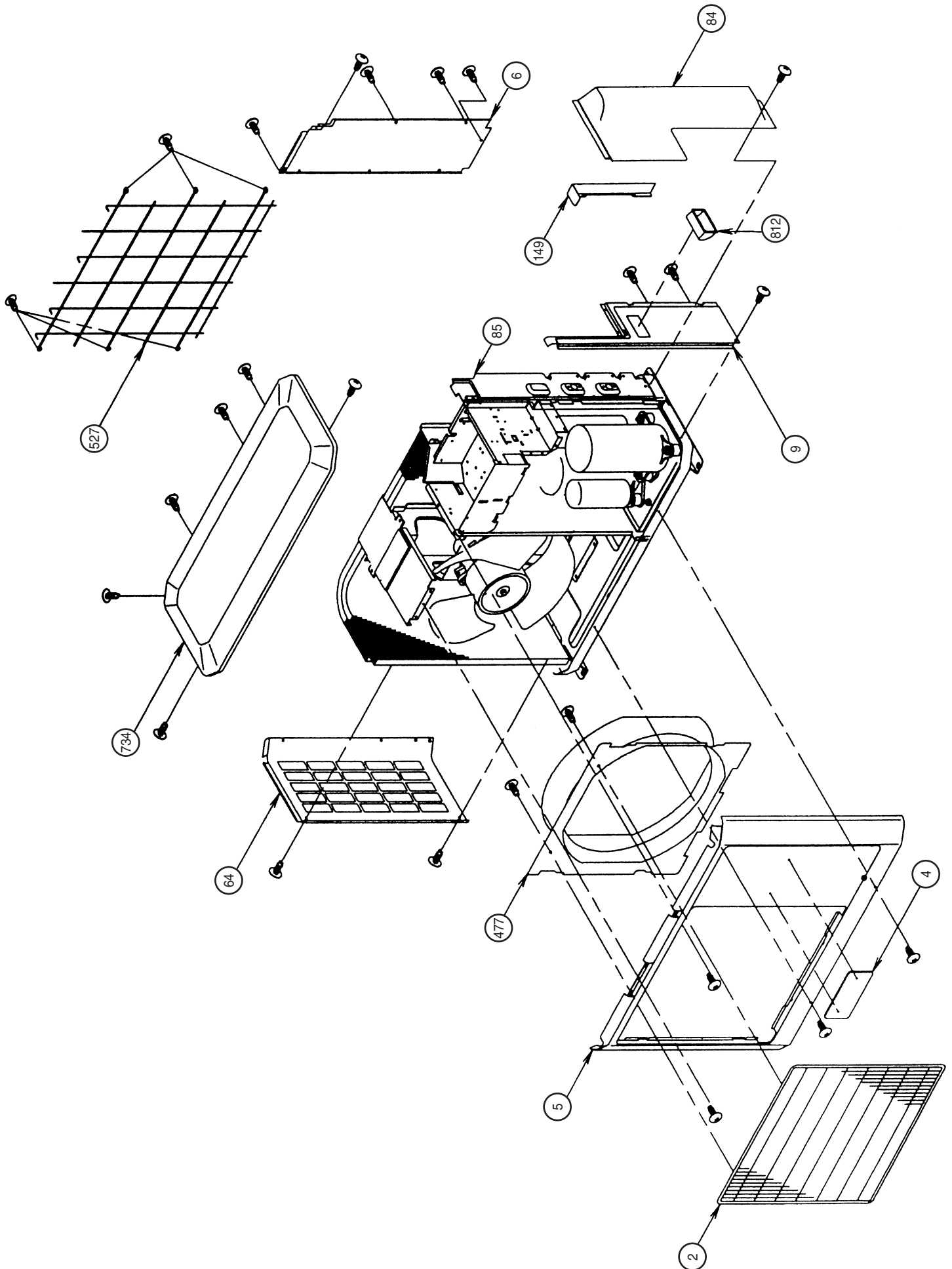

Models : AOH19FSAB2  
AOH19FGBB2

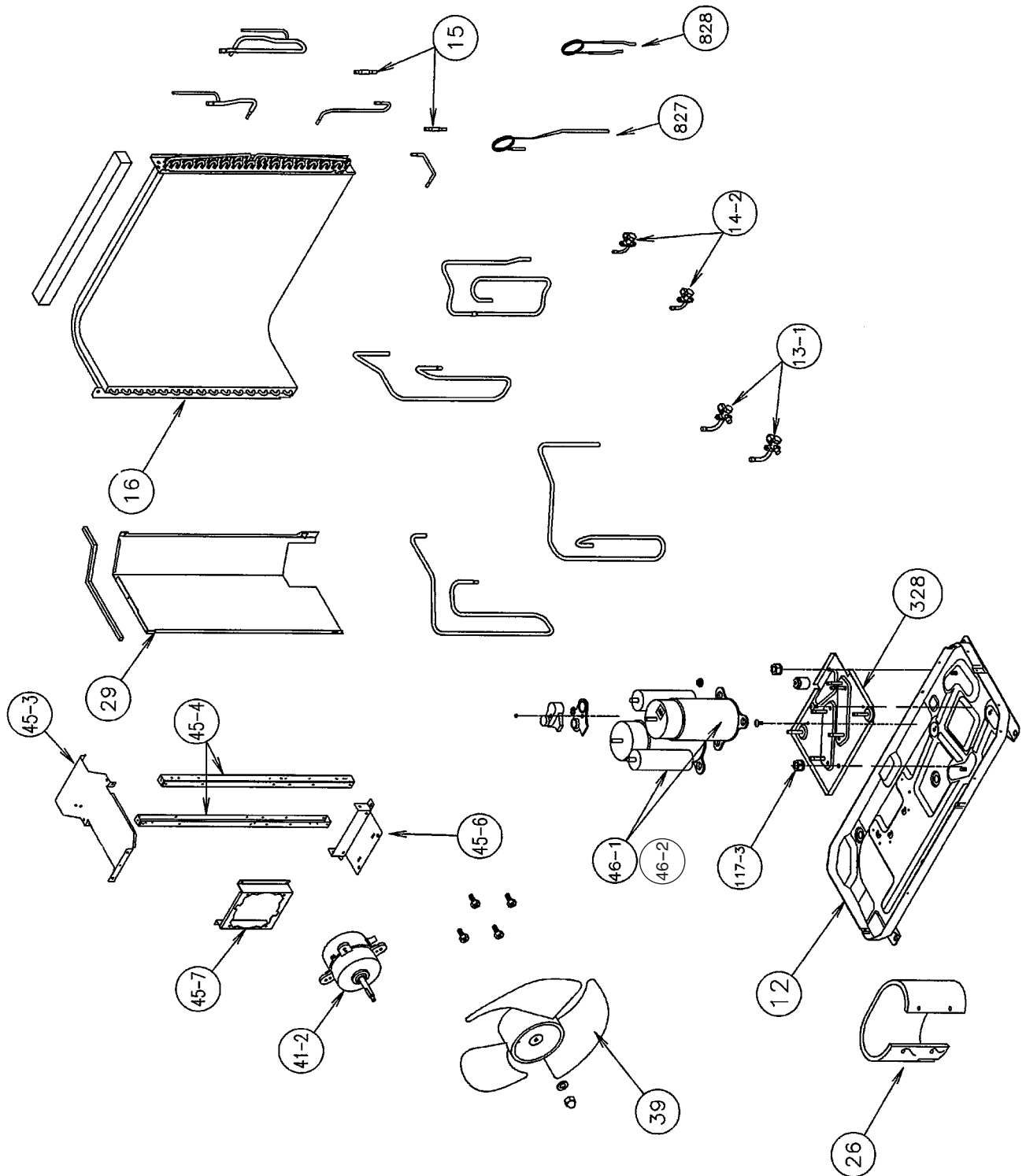

Models : AOH19FSAB2  
AOH19FGBB2

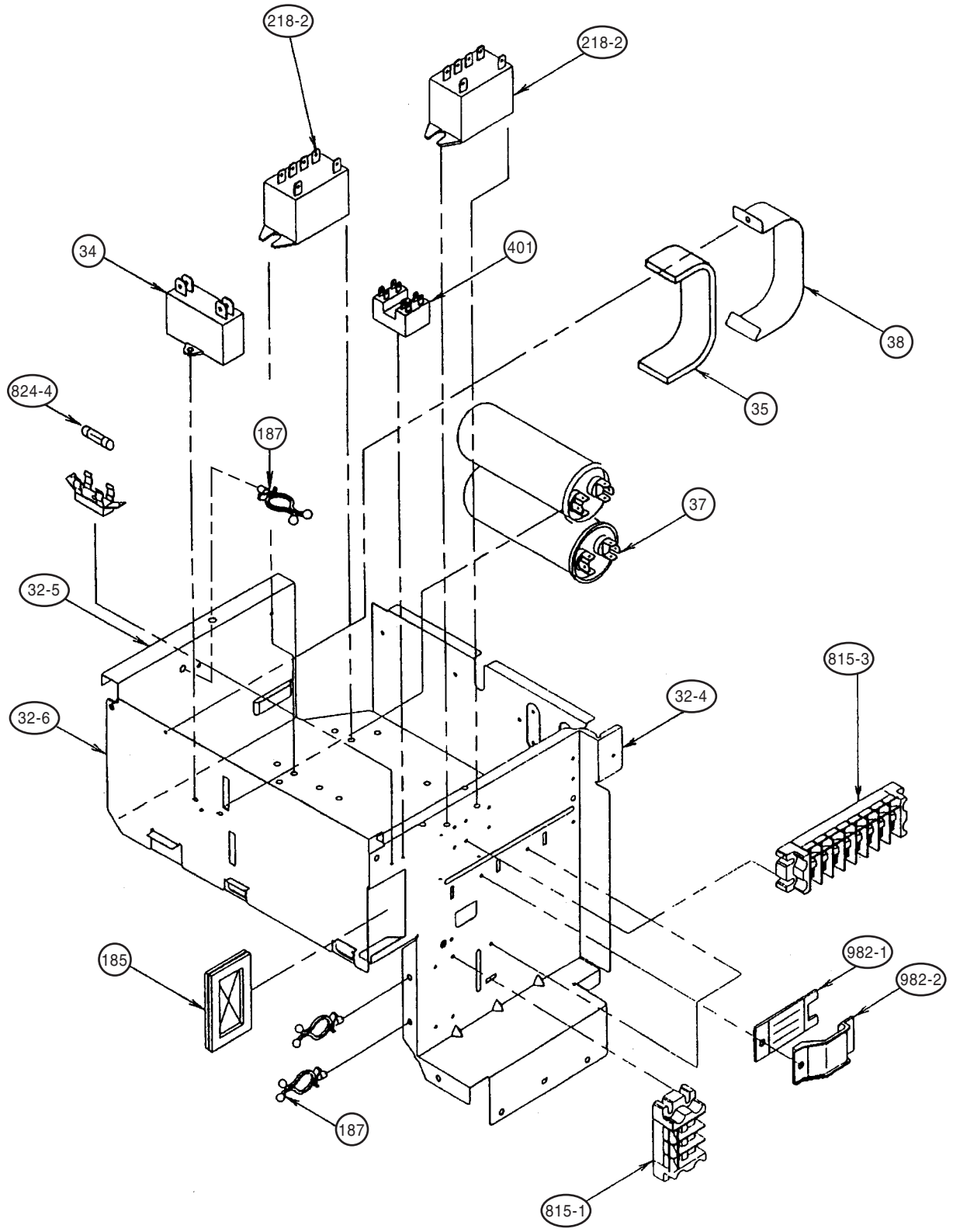

**Model : AOH19FSAB2**

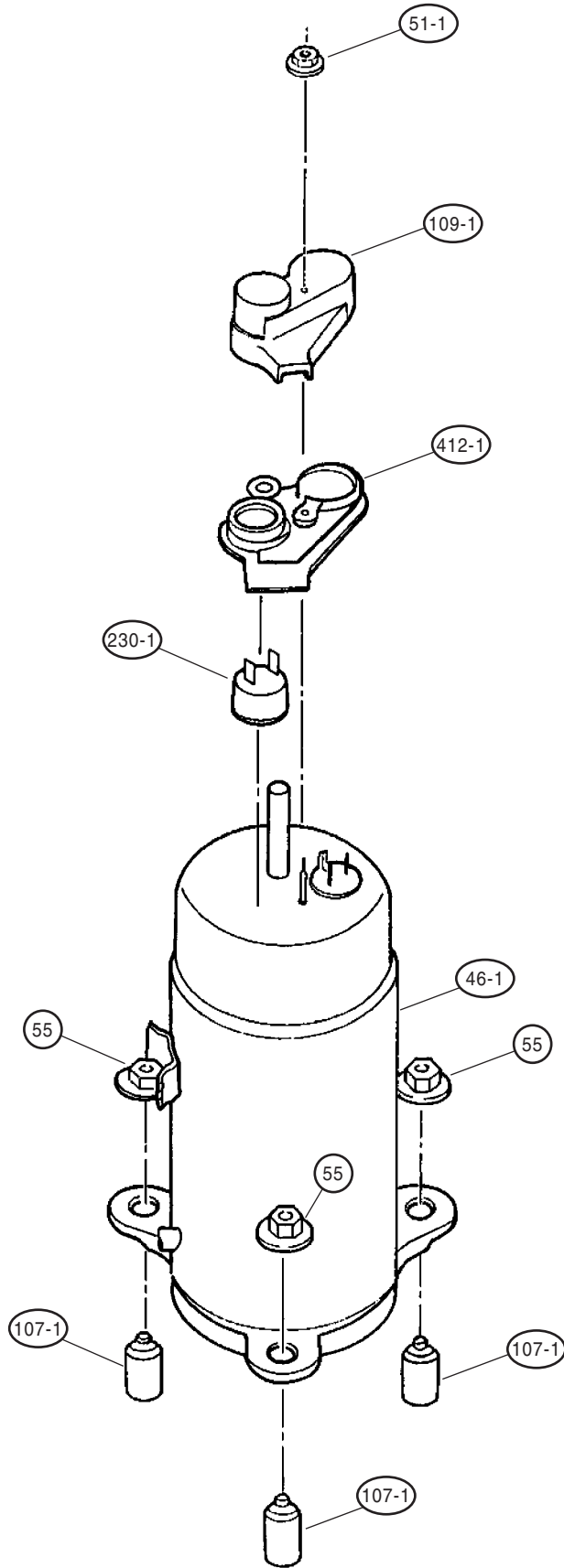

Model : AOH19FGBB2

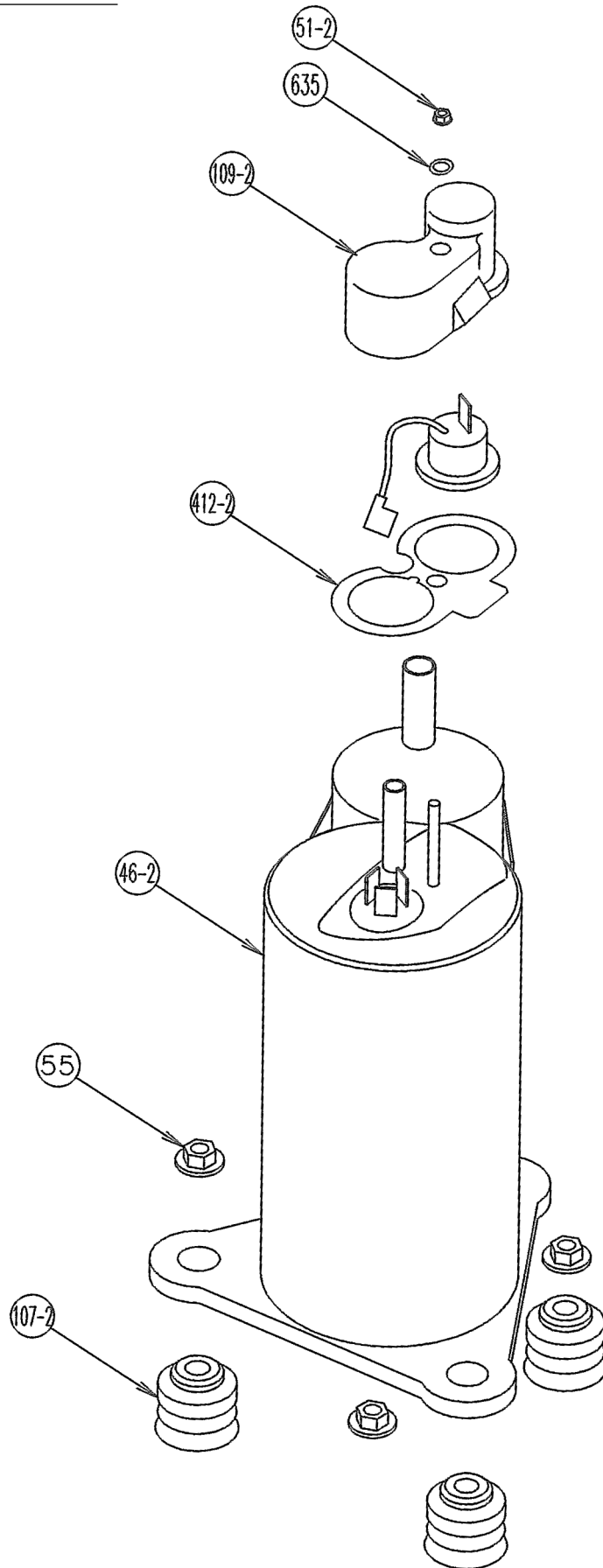

# PARTS LIST

## INDOOR UNIT

Ref. No.	Description	Part No.	Ord. Q'ty
		<b>ASH9FMAD</b>	
63	Front Panel Assy	9312172085	
65	Flow Control Panel-Z	9306058043	
69	Louver-A	9306055028	
74	Filter	9305444014	
108	Base	9309755062	
109	Casing Assy	9312173082	
122	Shaft Holder-B	9303066010	
127	Drain Hose Assy	9305550029	
146	Evaporator Assy	9601844013	
151	Control Box	9330007017	
158	Connecting Pipe Assy	9306416010	
164	Fan Motor Assy-IN	9601844013	
169	Cross-Flow Fan Assy	9307836015	
184	Thermistor Spring	313728262708	
196	Clamp SKB-150	313035356905	
233	Power Transformer	9900028015	
235	Thermistor (Pipe)	9702039059	
236	Controller PCB Assy	9704865045 (EZ-00205WSE-C)	
240	Remote Controller Assy	9374322220	
281	Bracket (Pipe)	9306063009	
283	Bushing-A	9303529010	
323	Louver-B	9306056025	
385	PCB (Indicator + Power supply)	9704871015 (EZ-002SWSE-F)	
401	Wall Hook Bracket	9304358008	
440	Flow Control Panel-U	9306057046	
522-1	Gear-A	9306062002	
523	Gear Bracket	9306407001	
652-1	Thermistor Holder Pipe	313714262805	
668	Screw w/Washer	313681304205	
759-1	Intake Grille-B	9330002012	
764	Drain Cap Assy	9304150008	
767-1	Bottom Cover	9330004016	
777	Clamper(Grille)	9306755010	
815	Terminal	9900040055	
850	Window (Receiver)	9330003019	
872	Indicator Case	9330009011	
873	Lamp Cover	9330014015	
874	Control Box Cover	9330008014	
876	Step Motor	9900139018	
----	Thermister (Room)	9700801115	

When you order parts, please make a photocopy of this page and fill the number of the parts in the "Order" column.

**OUTDOOR UNIT**







Ref. No.	Description	Part No.		Ord. Q'ty	Ref. No.	Description	Part No.		Ord. Q'ty
		AOH19FSAB2	AOH19FGBB2				AOH19FSAB2	AOH19FGBB2	
2	Fan Cover	9371187013	9371187013		51-2	Attachment (Nut)	----	9359430018	
4	Emblem	313791088308	313791088308		55	Special Nut M8 (For Comp.)	9355091008	9355091008	
5	Cabinet-A, Painted	9359797043	9359797043		64	Cabinet-Left, Painted	9359840046	9359840046	
6	Cabinet-C, Painted	9359825029	9359825029		84	Valve Cover	9359834014	9359834014	
9	Cabinet-B, Painted	9359824022	9359824022		85	Valve Plate Assy, Painted	9361251021	9361251021	
12	Base Assy, Painted	9359813019	9359813019		107-1	Rubber Seat (For Comp. )	9351507015	----	
13-1	3-Way Valve	9372205044	9372205044		107-2	Attachment (Rubber Seat-A)	----	9359425014	
14-2	2-Way Valve	9372204054	9372204054		109-1	Terminal Cover (For Comp.)	9302419008	----	
15	Strainer Assy	9366602019	9366602019		109-2	Terminal Cover (For Comp.)	----	9363263008	
16	Condenser Assy	9374627011	9374627011		117-3	Hex. Nut	301721180114	301721180114	
26	Compressor Cover A	9364595009	9364595009		149	Water Seal Plate	9359841029	9359841029	
29	Separate Wall	9359805014	9359805014		185	Rubber Bushing	313005066051	313005066051	
32-4	Control Box Metal-D	9361247000	9361247000		187	Clamp No. 1219	313361271706	313361271706	
32-5	Control Box Metal-E	9361248007	9361248007		218-2	Power Relay	9900239015	9900239015	
32-6	Control Box Metal-F	9361249004	9361249004		230-1	Ocr assy (MRA99134-9201)	9311143000	----	
34	Capacitor (Fan Motor)	9703306051	9703306051		328	Compressor Plate Assy	9359830030	9359830030	
35	Control Box Insulation-h	9361521001	9361521001		401	Terminal-2P	9701971015	9701971015	
37	Running Capacitor	9704436139	9704436139		412-1	Terminal Gasket (For Comp.)	9351505011	----	
38	Clamp Metal (Capacitor)	9352123009	9352123009		412-2	Attachment (Cover Gasket)	----	9362004008	
39	Propeller Fan	9359837015	9359837015		477	Bellmouth	9359809012	9359809012	
41-2	Fan Motor Induction-Out (MFB-30NTT)	9601754022	9601754022		527	Protective Net	9359845010	9359845010	
45-3	Motor Bracket-A	9369627002	9369627002		635	Attachment Washer (Gasket)	----	9359428015	
45-4	Motor Bracket-B	9371439013	9371439013		734	Top Plate, Painted	9359799023	9359799023	
45-6	Motor Bracket-D	9369630002	9369630002		812	Grip	9352157004	9352157004	
45-7	Motor Bracket center da	9373076018	9373076018		815-1	Terminal-3P	9358660027	9358660027	
46-1	Compressor Assy (802-141-65B)	9373010029	----		815-3	Terminal-8P	9358660119	9358660119	
46-2	Compressor (GK-120-PAB)	----	9373548027		824-4	Fuse (5A-250V)	0600285234	0600285234	
51-1	Special Nut (For Comp.)	313199233602	----		827	Capillary-tube A Assy	9360814142	9360814142	
					828	Capillary-tube B Assy	9360815149	9360815149	
					982-1	Cord Clamp	9356857009	9356857009	
					982-2	Cord Clamp-B	9356858006	9356858006	

When you order parts, please make a photocopy of this page and fill the number of the parts in the "Order" column.

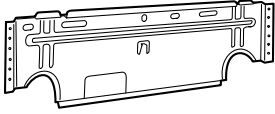

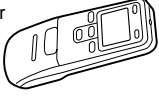

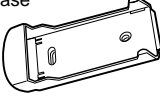
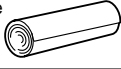
# STANDARD ACCESSORIES

## INDOOR UNIT ACCESSORIES

Name and Shape	Q'ty	Part No.
Wall hook bracket 	1	9304358008
Wall cap-B 	1	313714296205
Remote controller 	1	9374322220 (AR-JW22)
Battery (penlight) 	1 set	0600185534
Remote control unit holder case 	1	9305642014
Cloth tape 	1	9308117007
Tapping screw (big) ( $\phi$ 4 x 25) 	8	0700076046
Tapping screw (small) ( $\phi$ 3 x 12) 	2	0700019036

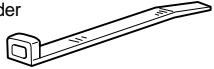
## OUTDOOR UNIT ACCESSORIES

Name and Shape	Q'ty	Part No.
Binder 	2	312300787605
Putty 	1	303020200114
Hexagon wrench 	1	9351228019

