



# MULTI AIR CONDITIONER WALL MOUNTED CASSETTE type

# SERVICE MANUAL



## Models

Indoor unit

Outdoor unit

ASH12UMBD

AOH24USBV2

AUH12UMAB

## CONTENTS

SPECIFICATIONS .....	1
OUTLINE AND DIMENSIONS .....	2
REFRIGERANT SYSTEM DIAGRAM .....	5
CIRCUIT DIAGRAM .....	6
INDOOR PCB CIRCUIT DIAGRAM .....	8
ERROR CONTENTS .....	10
DISASSEMBLY ILLUSTRATION .....	12
PARTS LIST .....	22
STANDARD ACCESSORIES .....	25

# SPECIFICATIONS

## ELECTRICAL DATA

TYPE		COOL & HEAT			
INDOOR UNIT		ASH12UMBD	ASH12UMBD x 2	AUH12UMAB	AUH12UMAB x 2
OUTDOOR UNIT		AOH24USBV2			
COOLING CAPACITY		3.50 kW	7.00 kW	3.50 kW	7.00 kW
HEATING CAPACITY		4.10 kW	8.20 kW	4.10 kW	8.20 kW
POWER SOURCE		230 V			
FREQUENCY		50 Hz			
RUNNING CURRENT	COOLING	5.8 A	11.2 A	5.8 A	11.2 A
	HEATING	6.1 A	11.4 A	6.1 A	11.4 A
INPUT WATTS	COOLING	1.30 kW	2.55 kW	1.30 kW	2.55 kW
	HEATING	1.38 kW	2.55 kW	1.38 kW	2.55 kW
E.E.R.	COOLING	2.69 kW/kW	2.75 kW/kW	2.69 kW/kW	2.75 kW/kW
	HEATING	2.97 kW/kW	3.22 kW/kW	2.97 kW/kW	3.22 kW/kW
MOISTURE REMOVAL		1.3 L/hr	2.6 L/hr	1.3 L/hr	2.6 L/hr
AIR CIRCULATION-High		520 m3/hr	520 m3/hr x 2	550 m3/hr	550 m3/hr x 2

## INDOOR UNIT

MODEL NAME		ASH12UMBD	AUH12UMAB
FAN MOTOR (cool / heat)	HIGH-SPEED	1,310 r.p.m. / 1,310 r.p.m.	760 r.p.m. / 760 r.p.m.
	MED-SPEED	1,260 r.p.m. / 1,180 r.p.m.	690 r.p.m. / 690 r.p.m.
	LOW-SPEED	1,190 r.p.m. / 1,030 r.p.m.	610 r.p.m. / 610 r.p.m.
	QUIET	1,100 r.p.m. / 970 r.p.m.	-----
DIMENSIONS H x W x D		257 x 808 x 187 mm	235 x 580 x 580 + 70 mm
WEIGHT GROSS / NET		10 kg / 8 kg	23 kg / 18 kg
NOISE LEVEL (cool / heat)	HIGH-SPEED	38 dB / 38 dB	42 dB / 43 dB
	MED-SPEED	37 dB / 35 dB	39 dB / 40 dB
	LOW-SPEED	35 dB / 31 dB	36 dB / 37 dB
	QUIET	33 dB / 29 dB	-----

## OUTDOOR UNIT

MODEL NAME		AOH24USBV2
COMPRESSOR TYPE		Hermetic type, Permanent split condenser, 2 pole, Single phase, Induction motor, Rotary
COMPRESSOR DISCRIMINATION		802 354 35B
POWER SOURCE		230V - 50Hz
REFRIGERANT R410A		900 g x 2
ADDITINAL CHARGE		10 g/m
CHARGELESS PIPE LENGTH		7.5 m
MAXIMUM PIPE LENGTH		15 m
FAN MOTOR		780 r.p.m.
DIMENSIONS H x W x D		700 x 900 x 330 mm
WEIGHT GROSS / NET		77 kg / 70 kg
NOISE LEVEL (cool / heat)		52 dB / 53 dB

## OUTLINE AND DIMENSIONS

INDOOR UNIT (Wall mounted type)

Model : ASH12UMBD

(Unit : mm)

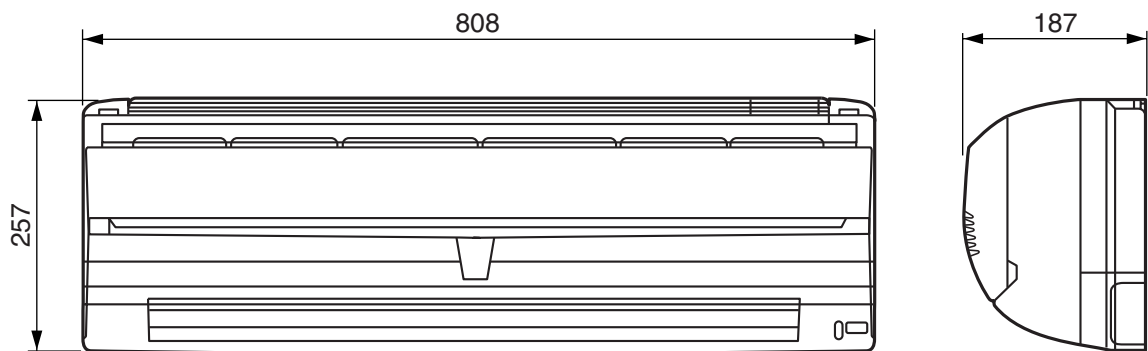

INDOOR UNIT (Cassette type)

Model : AUH12UMAB

(Unit : mm)

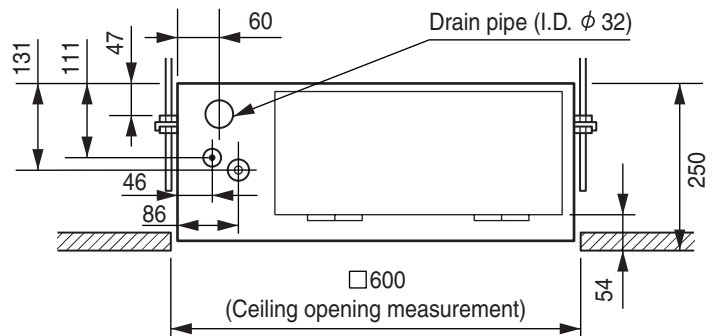
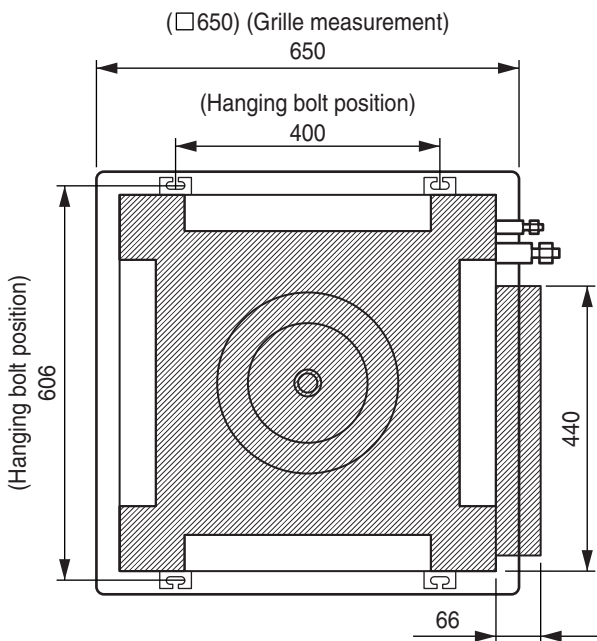
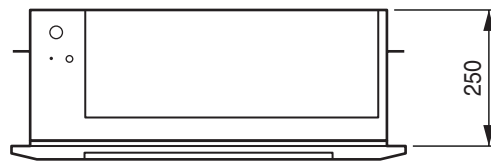
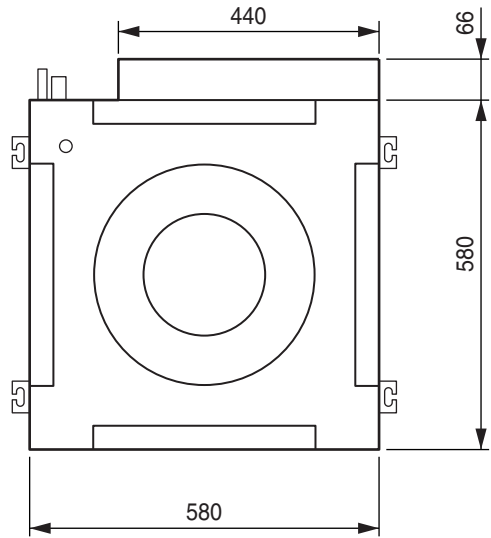
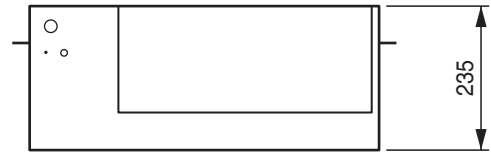
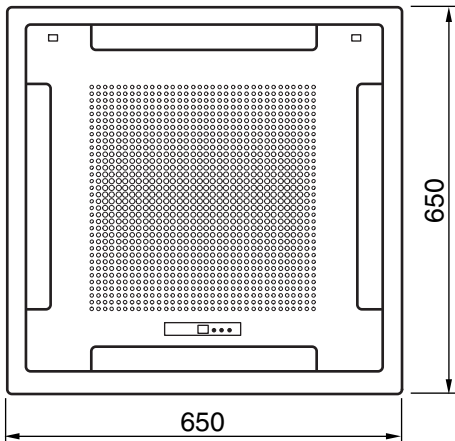
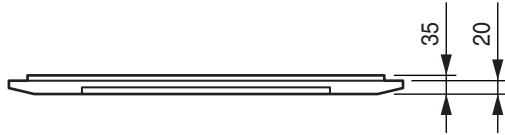

OUTDOOR UNIT  
Model : AOH24USBV2  
(Unit : mm)

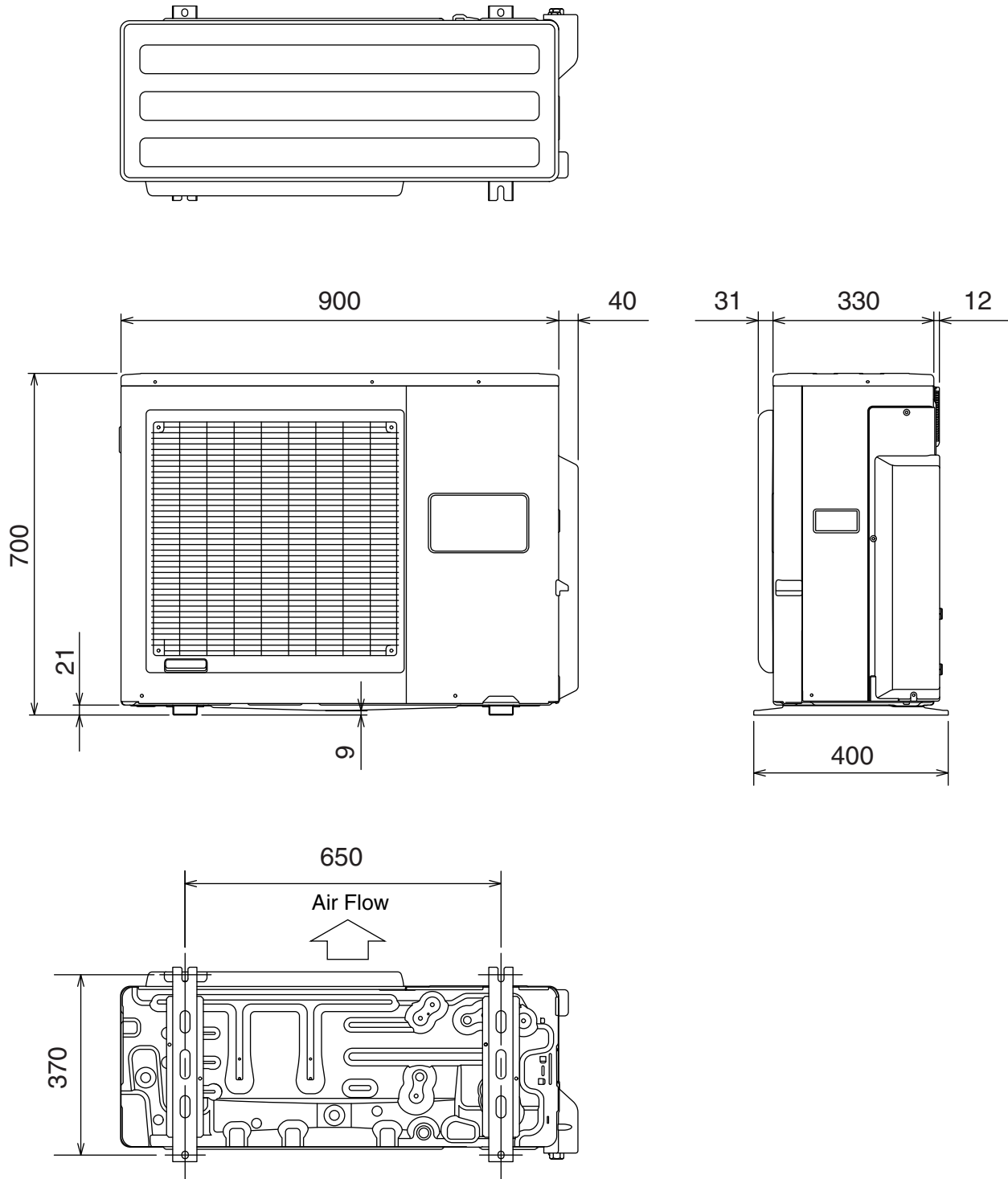

# REFRIGERANT SYSTEM DIAGRAM

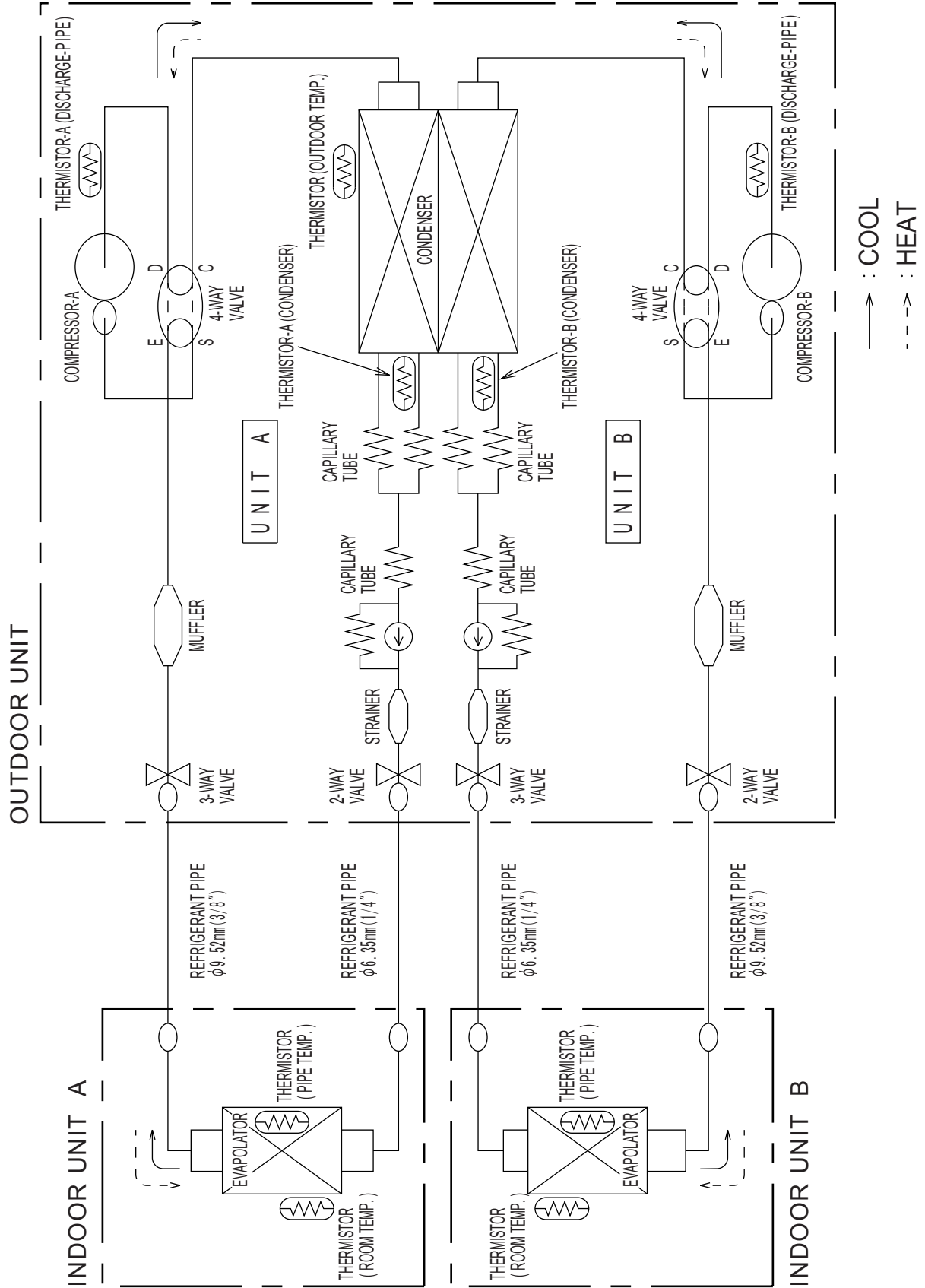

# CIRCUIT DIAGRAM

Models : ASH12UMBD / AOH24USBV2

## INDOOR UNIT

Wall Mounted type

Wall Mounted type

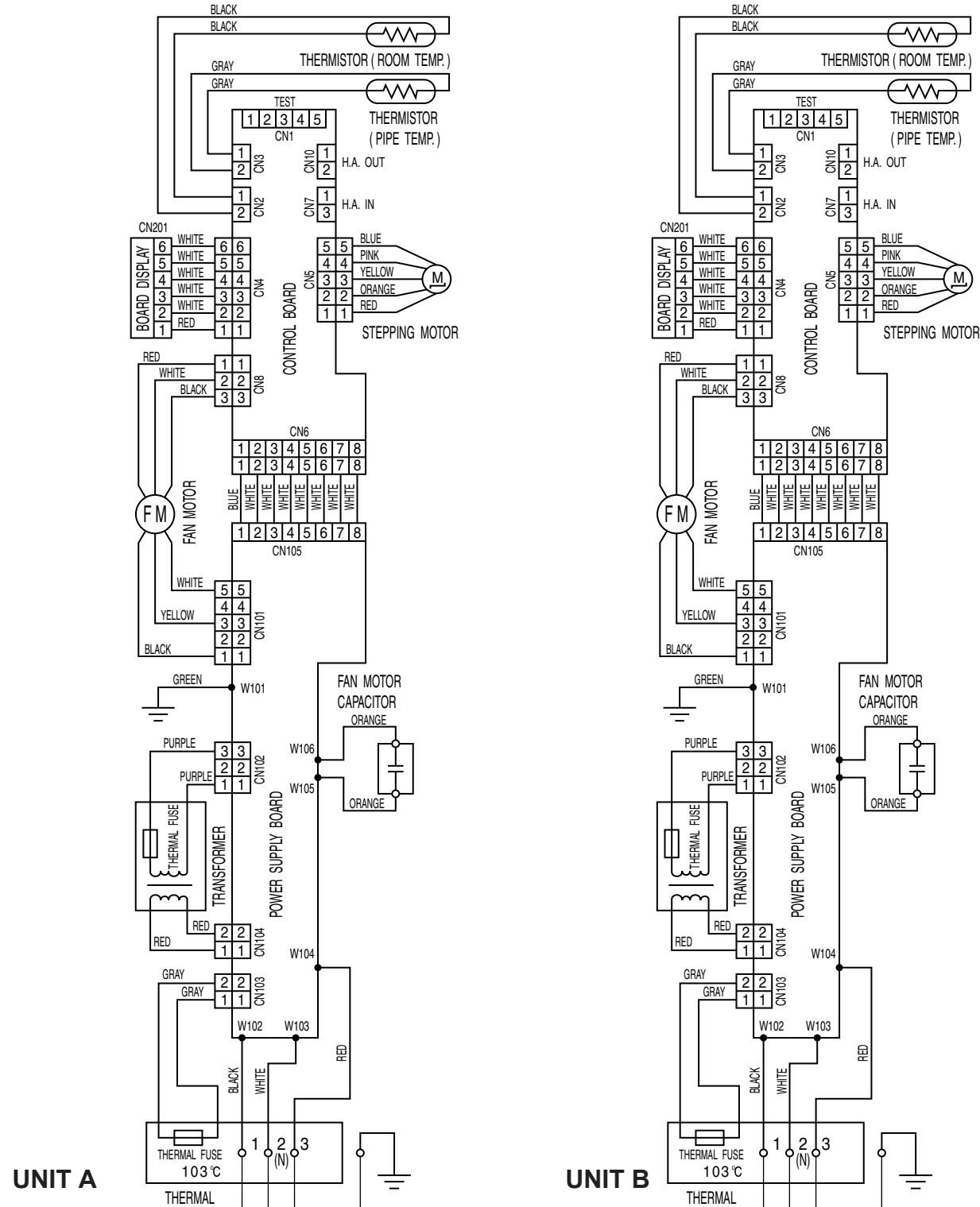

## OUTDOOR UNIT

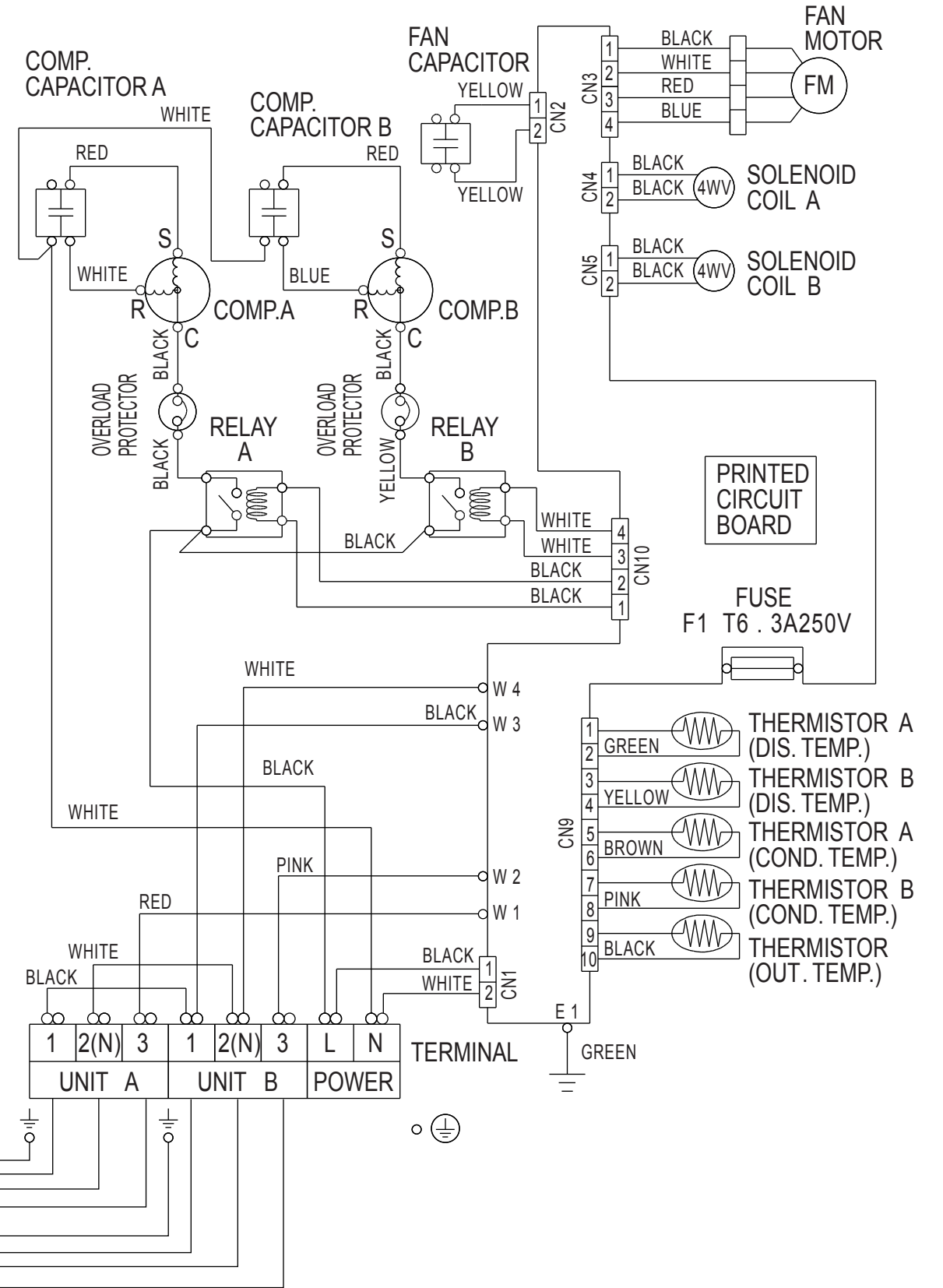

### INDOOR UNIT

#### Cassette type

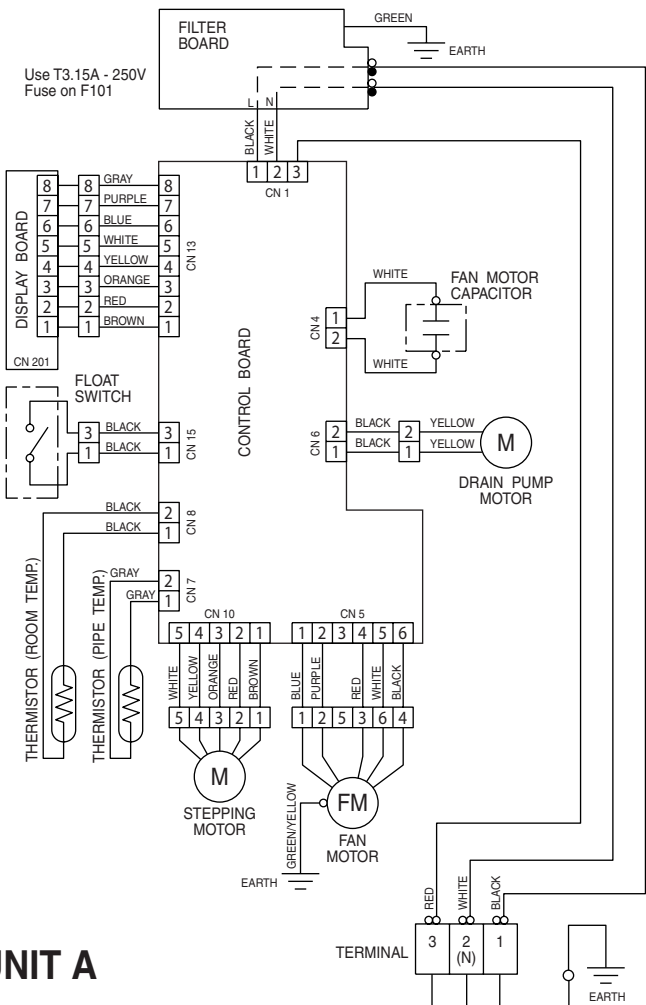

#### Cassette type

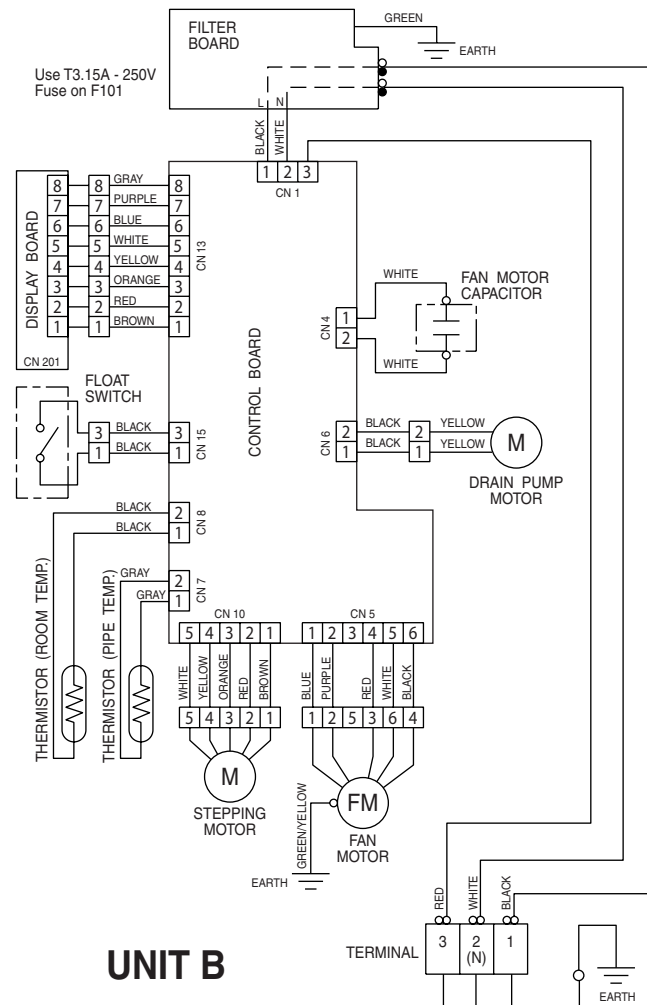

UNIT A

UNIT B

### OUTDOOR UNIT

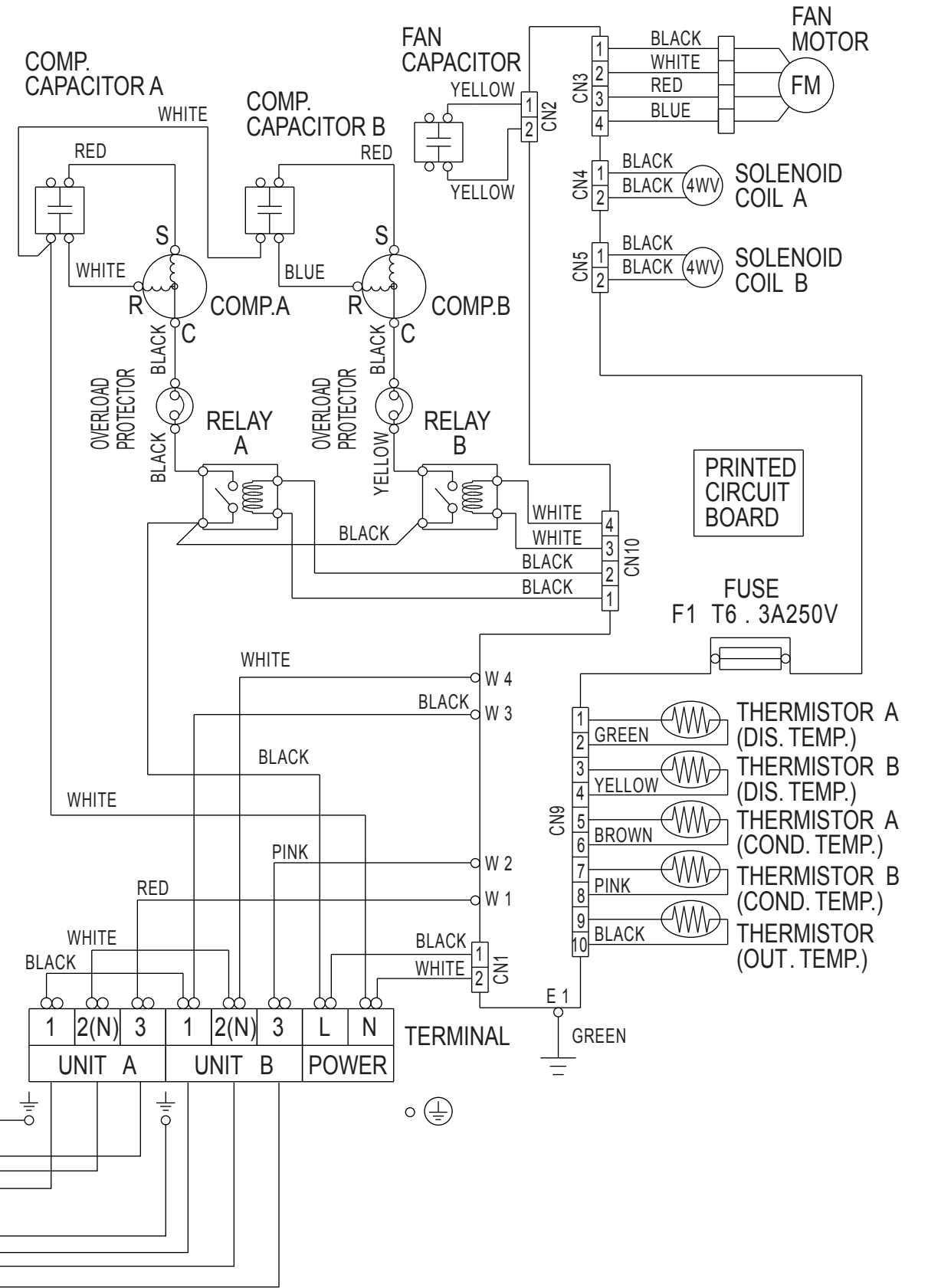



# INDOOR PCB CIRCUIT DIAGRAM

Model : ASH12UMB

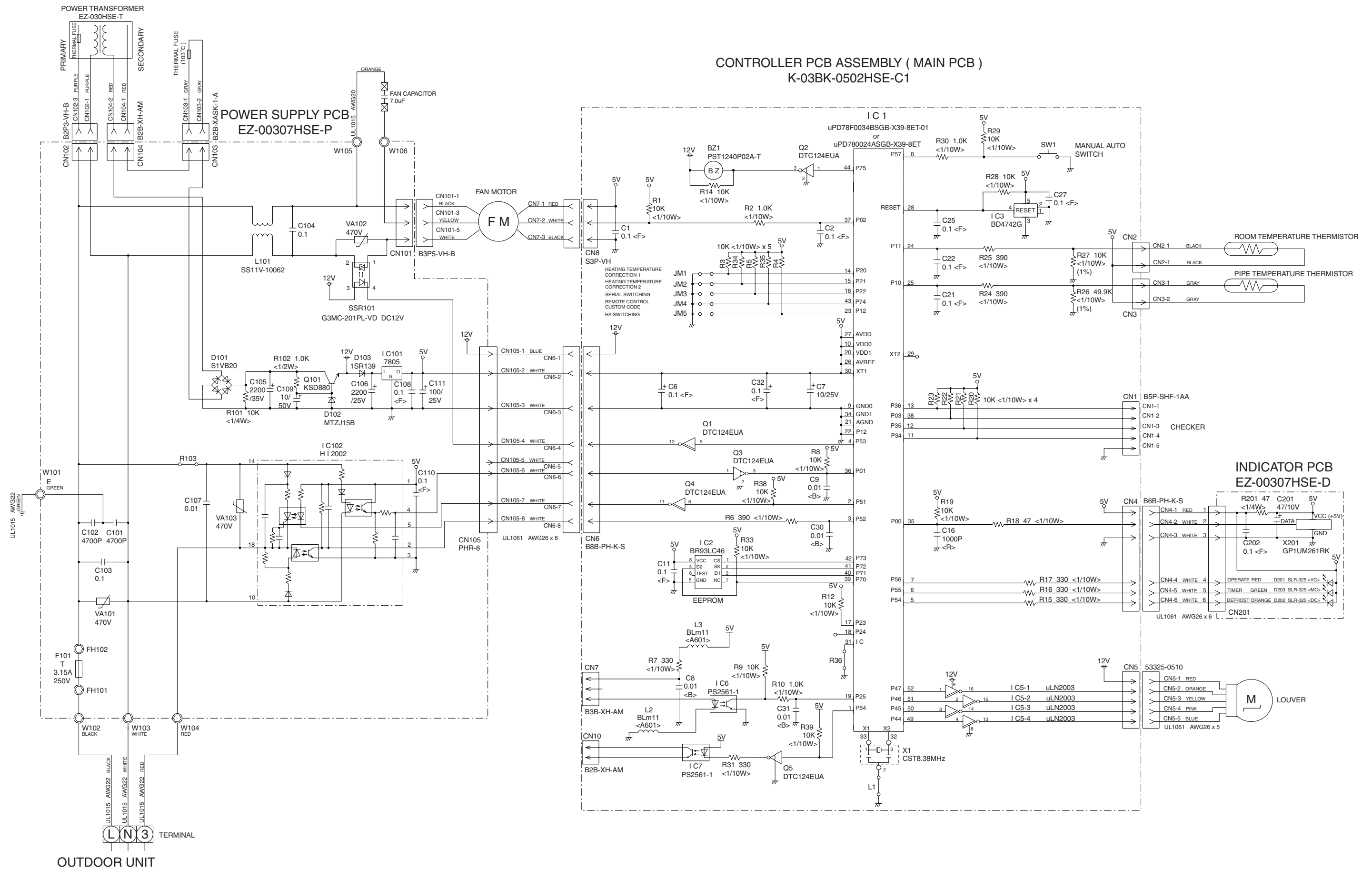

CONTROLLER PCB ASSEMBLY ( MAIN PCB )  
EZ-0032EHSE-C

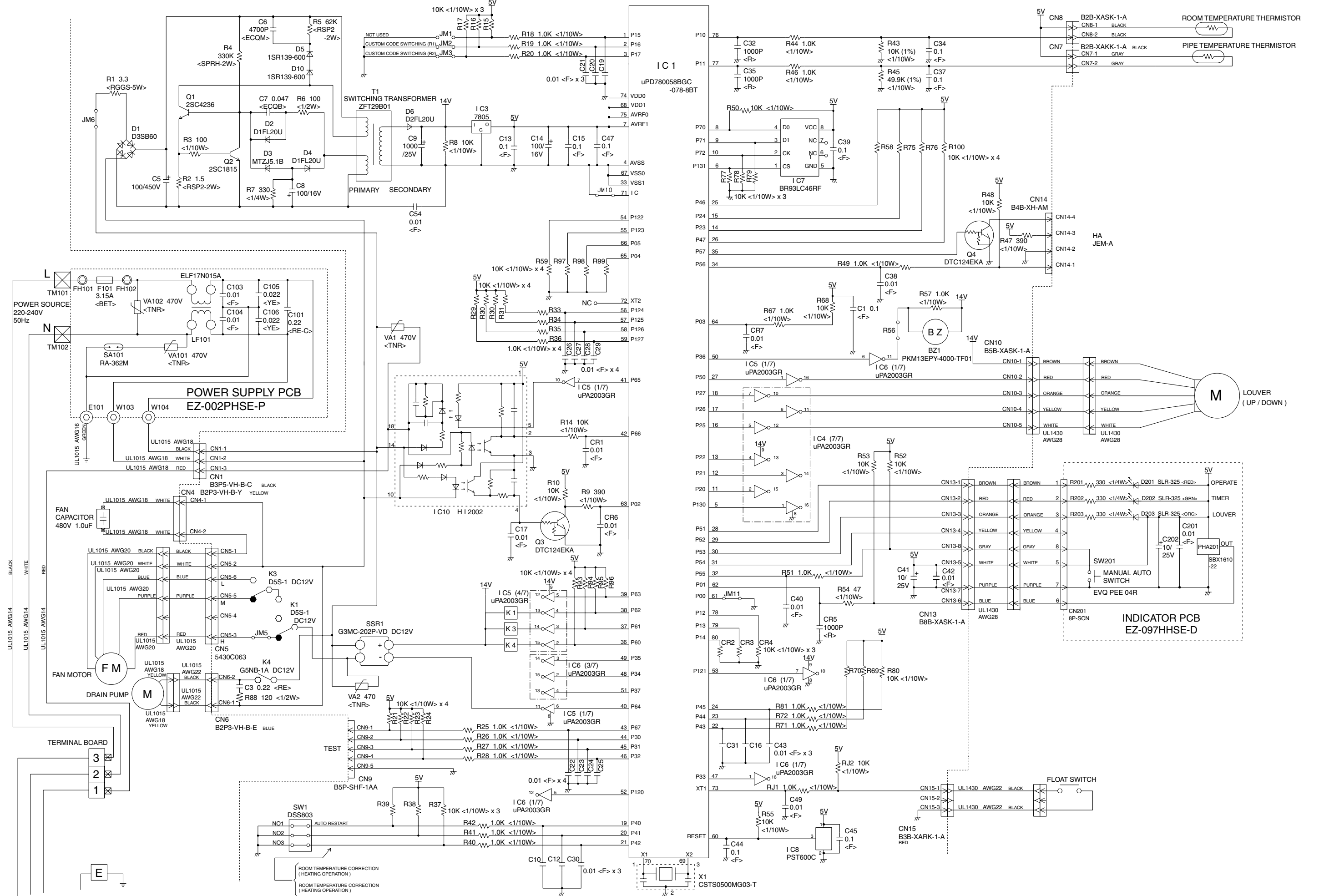

OUTDOOR UNIT

# ERROR CONTENTS

## INDOOR UNIT (Wall Mounted type)

○ : Fast flashing      ● : Slow flashing

Operation lamp : Red lamp

Timer lamp : Green lamp

Large division indication			Small division indication		
Error contents	LED indication		Error contents	LED indication	
circuit board error (indoor unit)	Red lamp Green lamp	○ ○	----	----	----
thermistor error (indoor unit)	Red lamp Green lamp	● (2 times) ○	thermistor error (room temp.)	Red lamp Green lamp	○ ● (2 times)
			thermistor error (heat exchanger)	Red lamp Green lamp	○ ● (3 times)
control unit error (indoor unit)	Red lamp Green lamp	● (4 times) ○	MANUAL AUTO button error	Red lamp Green lamp	○ ● (2 times)
			power source Hz decision error	Red lamp Green lamp	○ ● (4 times)
serial error	Red lamp Green lamp	● (5 times) ○	serial reverse transmission error	Red lamp Green lamp	○ ● (2 times)
			serial order transmission error	Red lamp Green lamp	○ ● (3 times)
fan motor error (indoor unit)	Red lamp Green lamp	● (6 times) ○	lock error	Red lamp Green lamp	○ ● (2 times)
			r.p.m error	Red lamp Green lamp	○ ● (3 times)
thermistor error (outdoor unit)	Red lamp Green lamp	○ ● (2 times)	----	----	----

When an error occurs, "Large division indication" is indicated first.

Secondly, "Small division indication" is indicated by pushing "Test" button of remote controller.

## INDOOR UNIT (CASSETTE TYPE)

○ : Fast flashing      ● : Slow flashing

Error display			Error contents
OPERATION lamp	TIMER lamp	SWING lamp	
○	○	Goes off	Model information abnormal (permanent type)
● 4 times	○	Goes off	Drain abnormal (permanent type)
● 6 times	○	Goes off	Indoor fan abnormal
● 2 times	○	Goes off	Room air temperature thermistor open circuit
		○	Room air temperature thermistor short circuit
● 3 times	○	Goes off	Piping thermistor open circuit
		○	Piping thermistor short circuit
● 5 times	○	Goes off	Indoor unit - outdoor unit miswiring

## OUTDOOR UNIT

When a malfunction occurs in the outdoor unit, the LEDs on the circuit board light to indicate the error. Refer to the following table for the description of each error according to the LEDs.

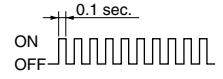
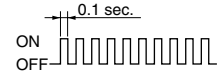
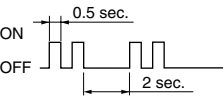
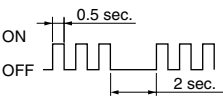
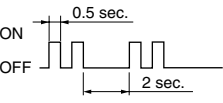
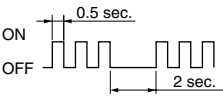
Error display		Error contents
LED 1	LED 2	
 <p>Quick flash continued</p>	 <p>Quick flash continued</p>	Model abnormal or EEPROM abnormal
 <p>2 quick flash repeated</p>	Dislighting continued	UNIT A Discharge temperature sensor error
 <p>3 quick flash repeated</p>	Dislighting continued	UNIT A Outdoor heat exchanger temperature sensor error
4 quick flash repeated	Dislighting continued	Outdoor temperature sensor error
5 quick flash repeated	Dislighting continued	UNIT A Communication signal error
6 quick flash repeated	Dislighting continued	UNIT A Indoor unit error
7 quick flash repeated	Dislighting continued	UNIT A Discharge temperature abnormal
Dislighting continued	 <p>2 quick flash repeated</p>	UNIT B Discharge temperature sensor error
Dislighting continued	 <p>3 quick flash repeated</p>	UNIT B Outdoor heat exchanger temperature sensor error
Dislighting continued	5 quick flash repeated	UNIT B Communication signal error
Dislighting continued	6 quick flash repeated	UNIT B Indoor unit error
Dislighting continued	7 quick flash repeated	UNIT B Discharge temperature abnormal

When the fault is cleared, the LED lamp goes off.

# DISASSEMBLY ILLUSTRATION

Model : ASH12UMBD

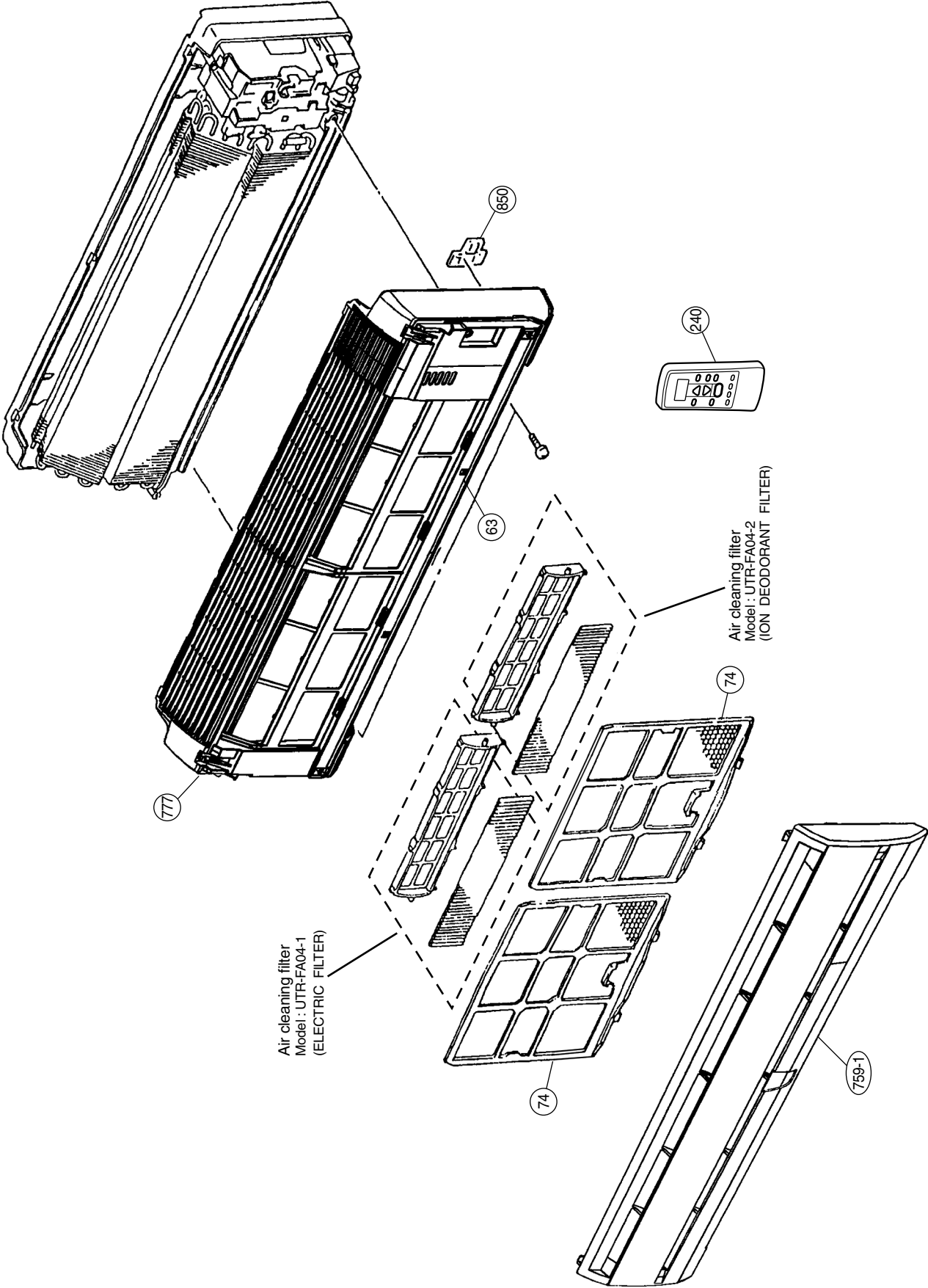

Model : ASH12UMBD

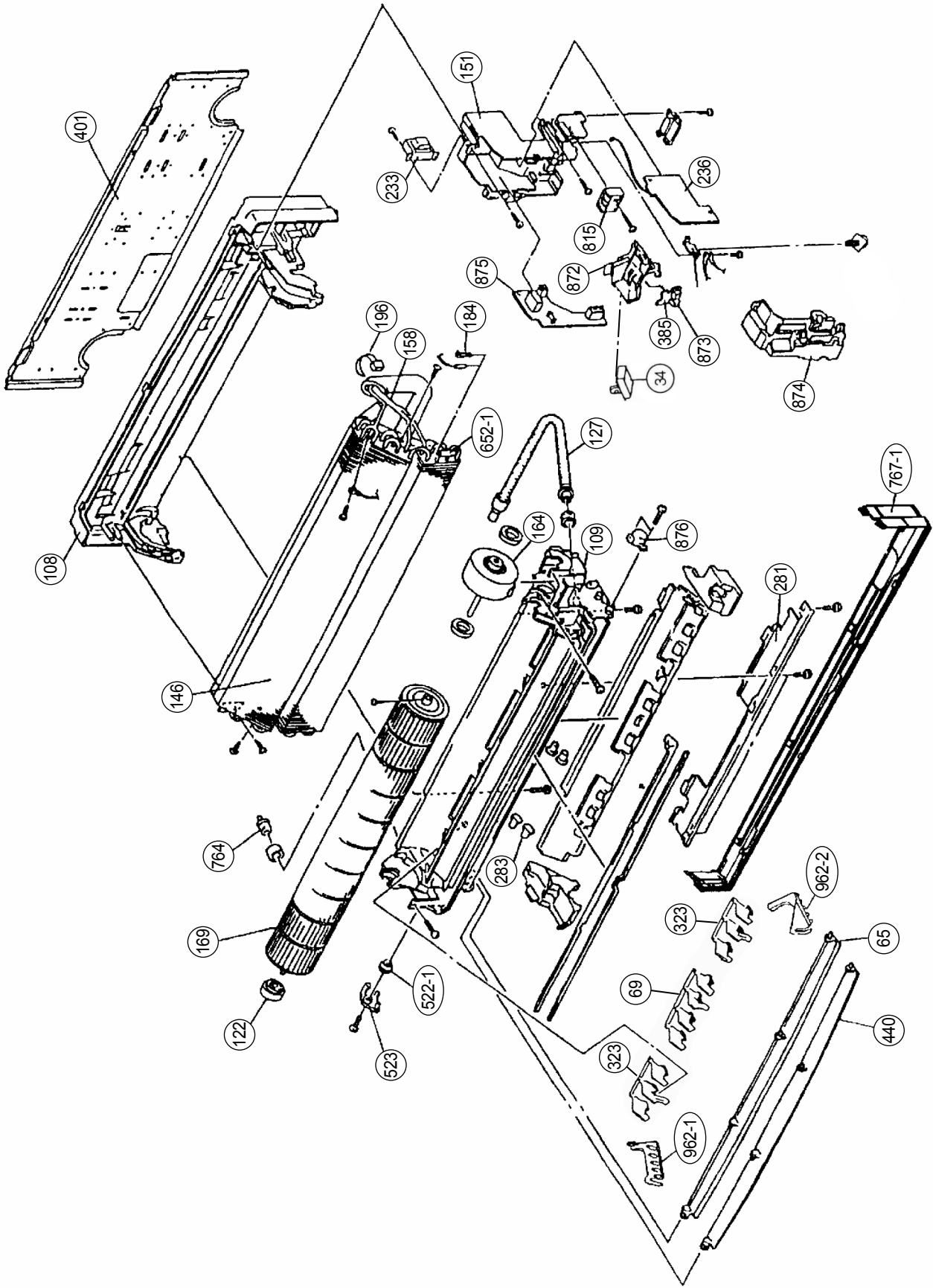

Model : AUH12UMAB

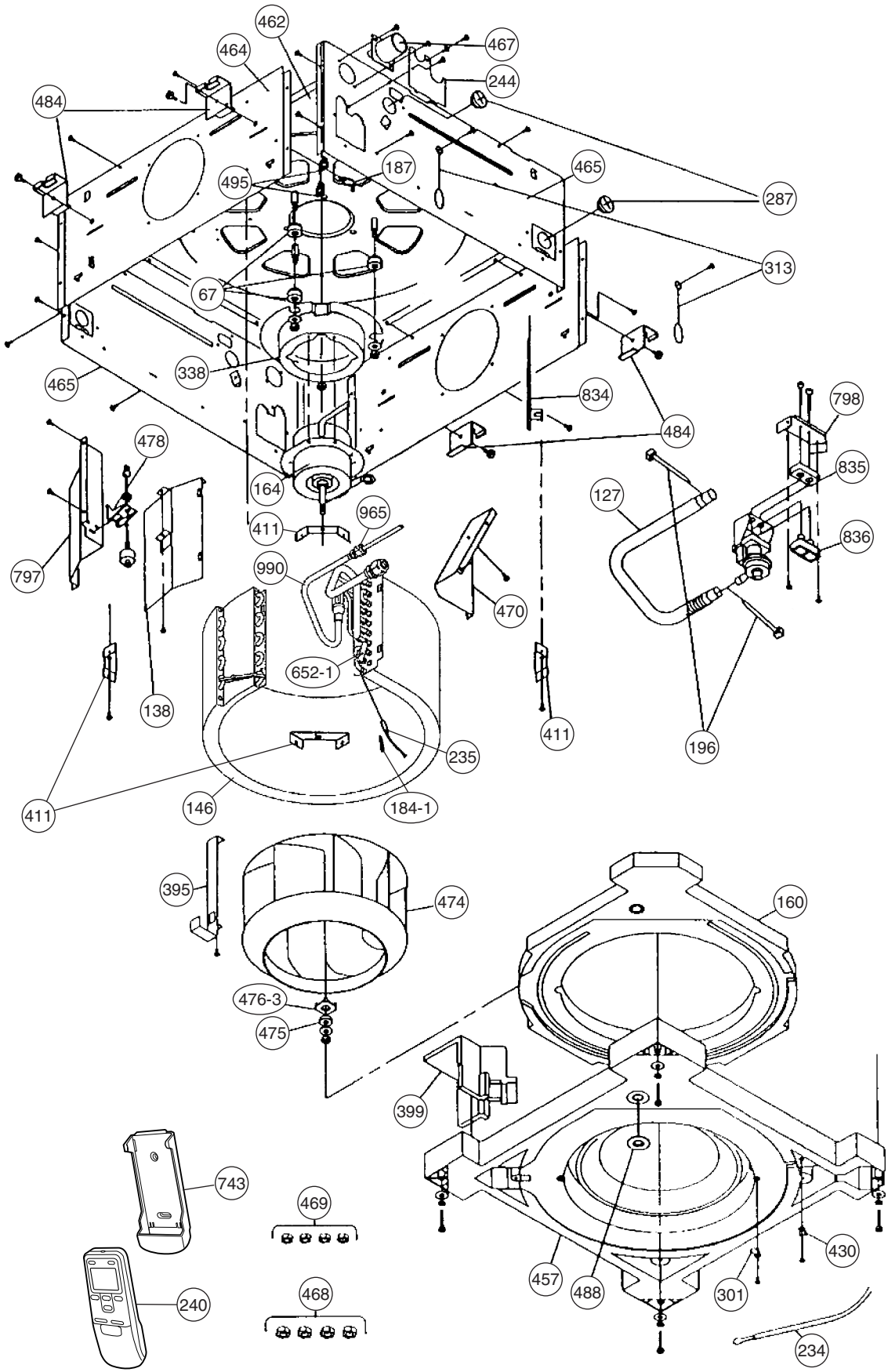

Model : AUH12UMAB

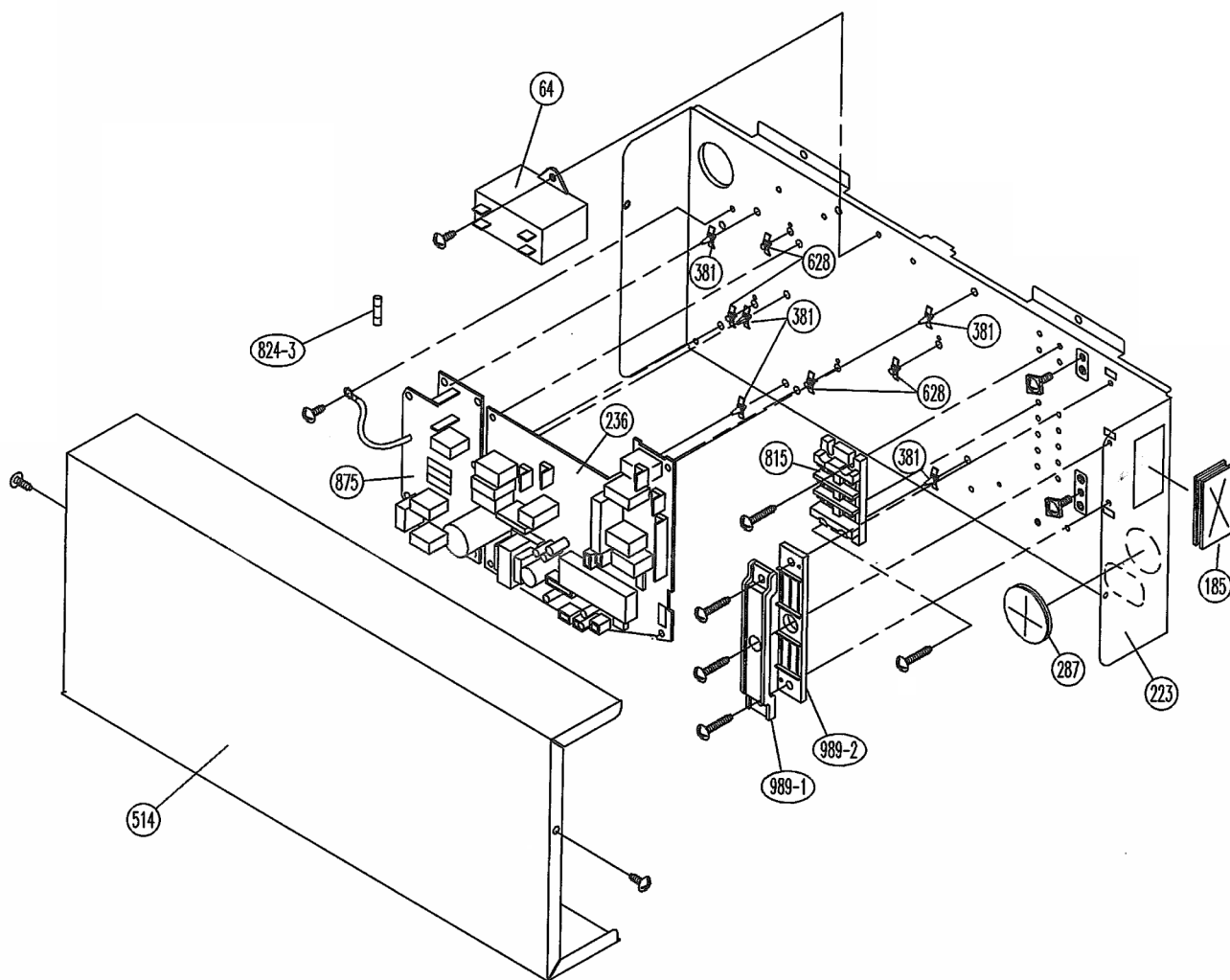



Model : UTG-UDGD-W

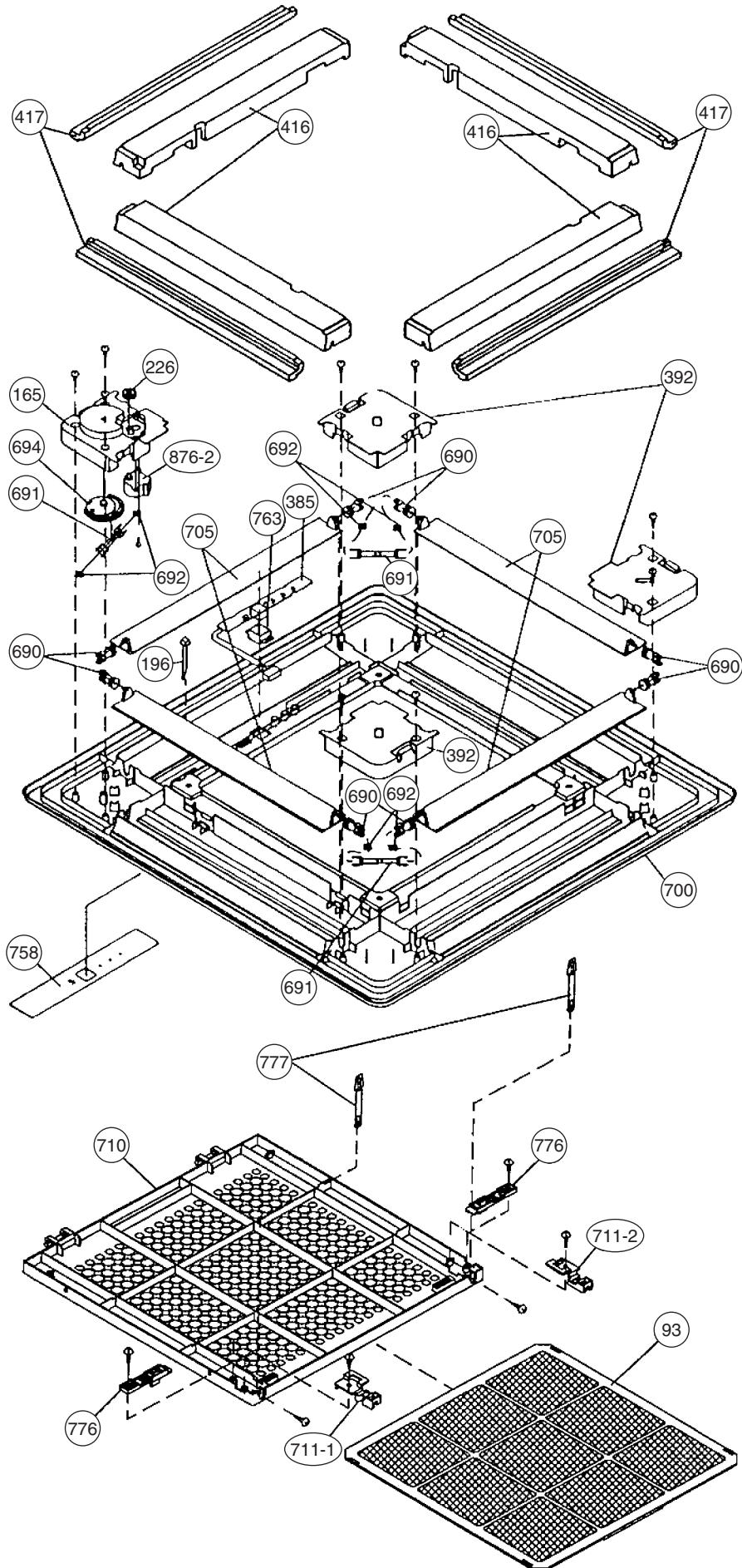

Model : AOH24USBV2

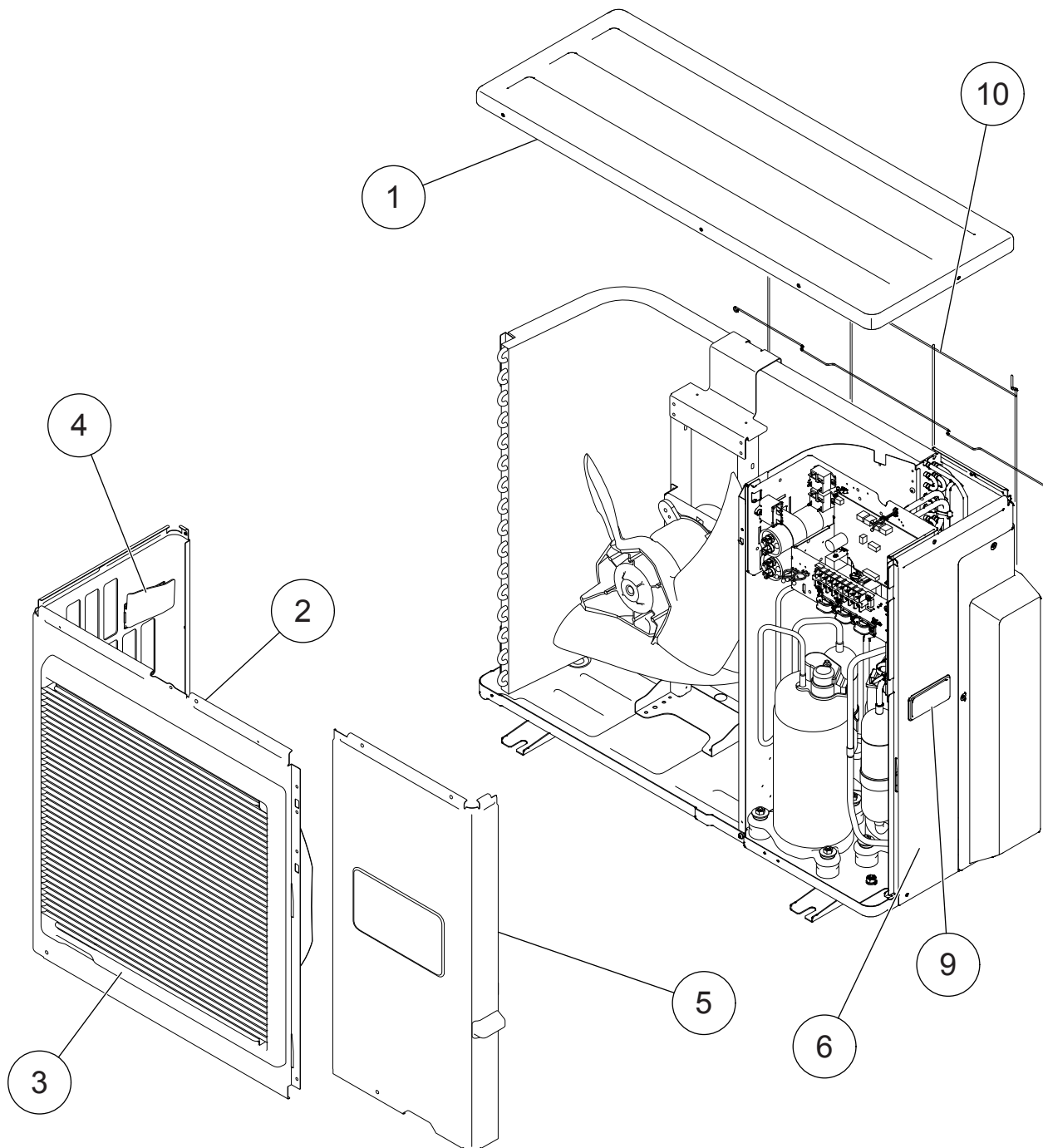

Model : AOH24USBV2

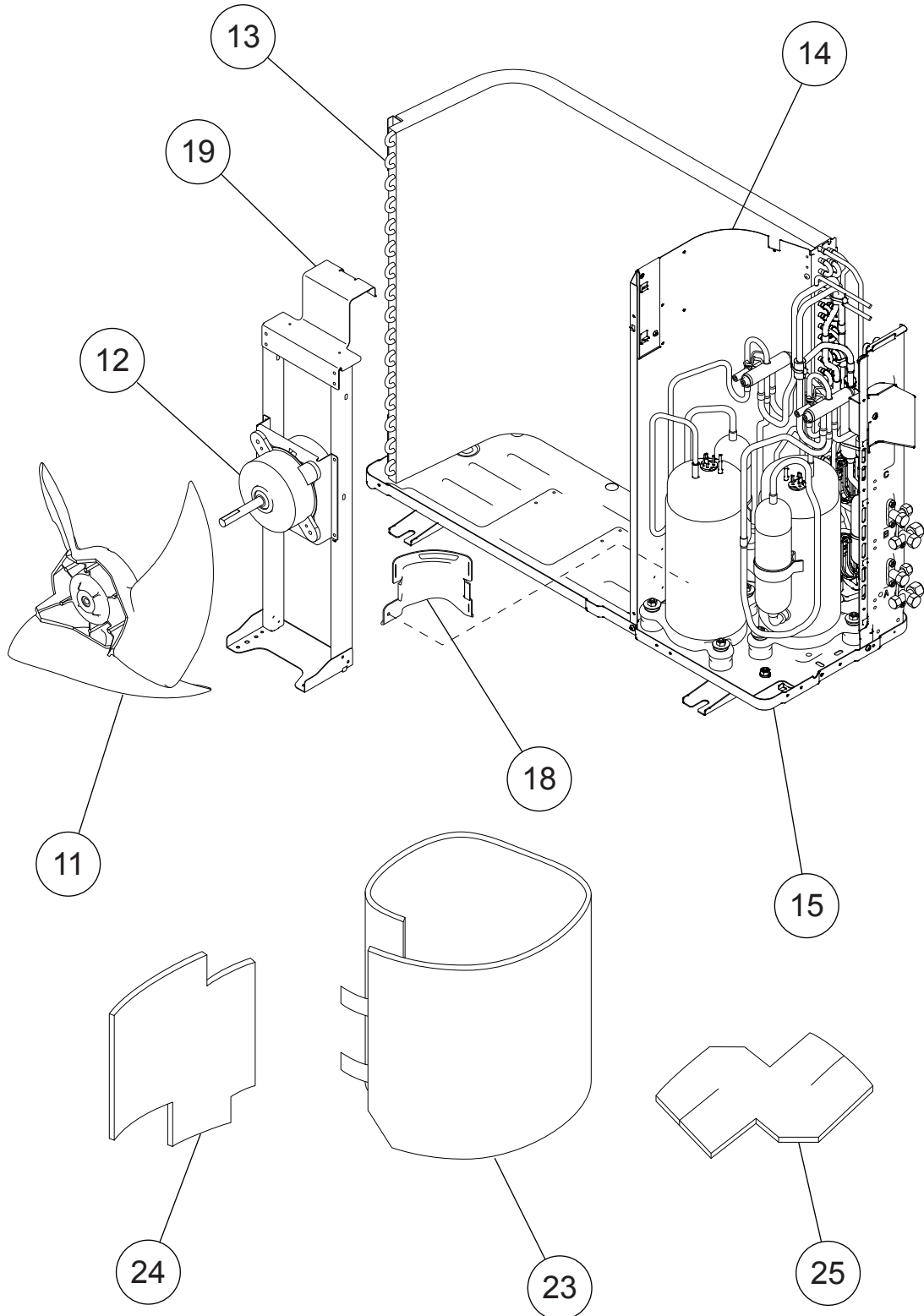

Model : AOH24USBV2

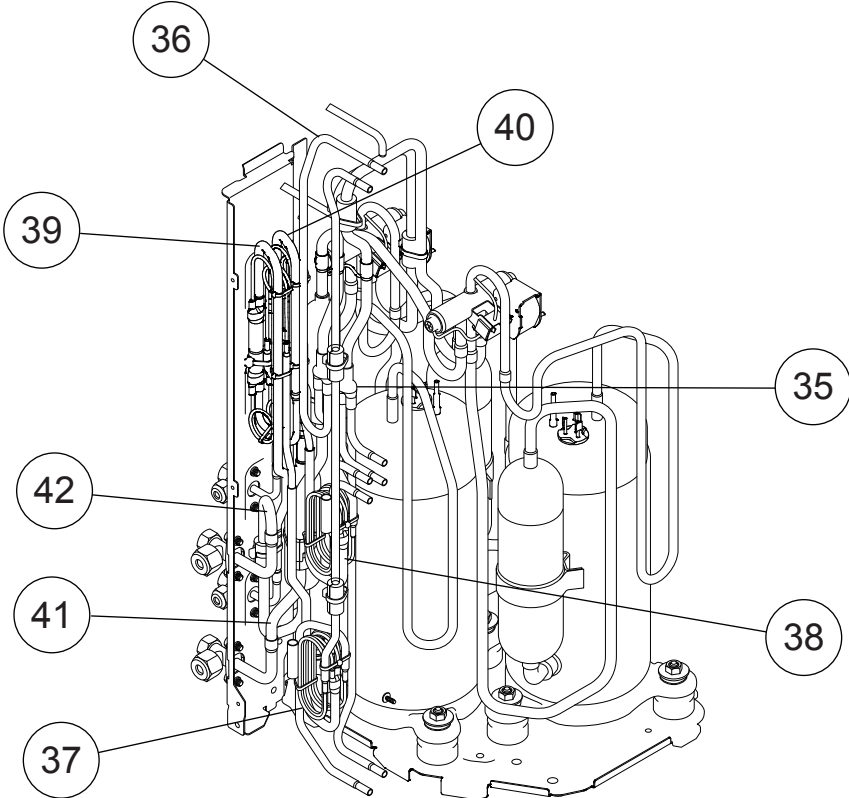
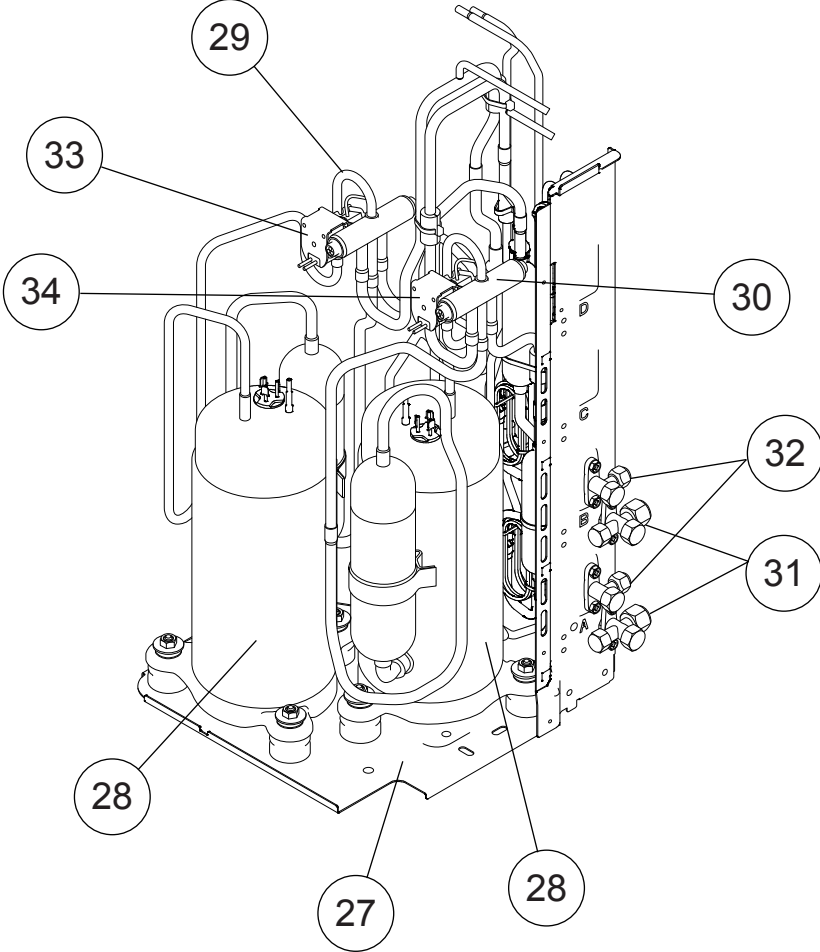

Model : AOH24USBV2

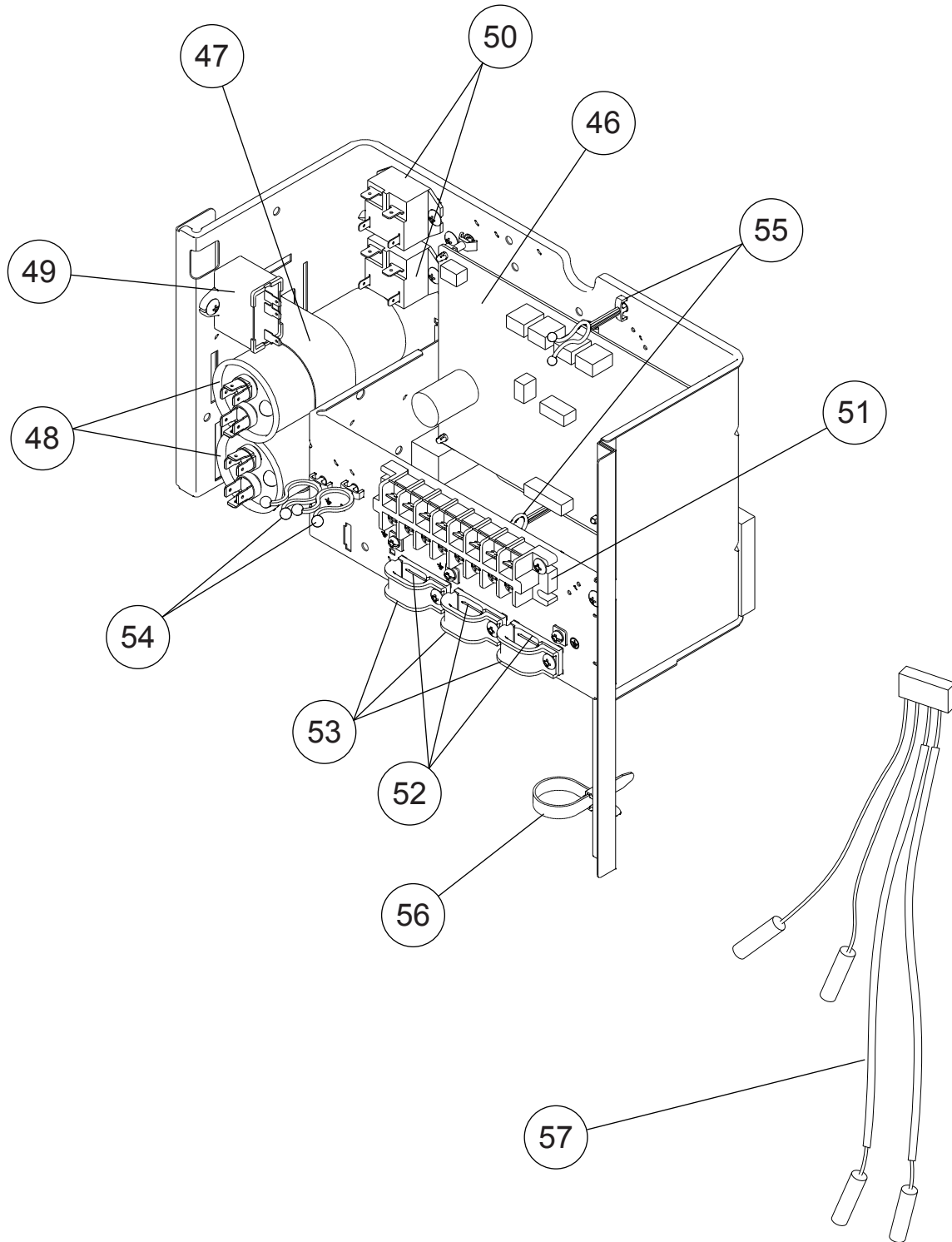

Model : AOH24USBV2

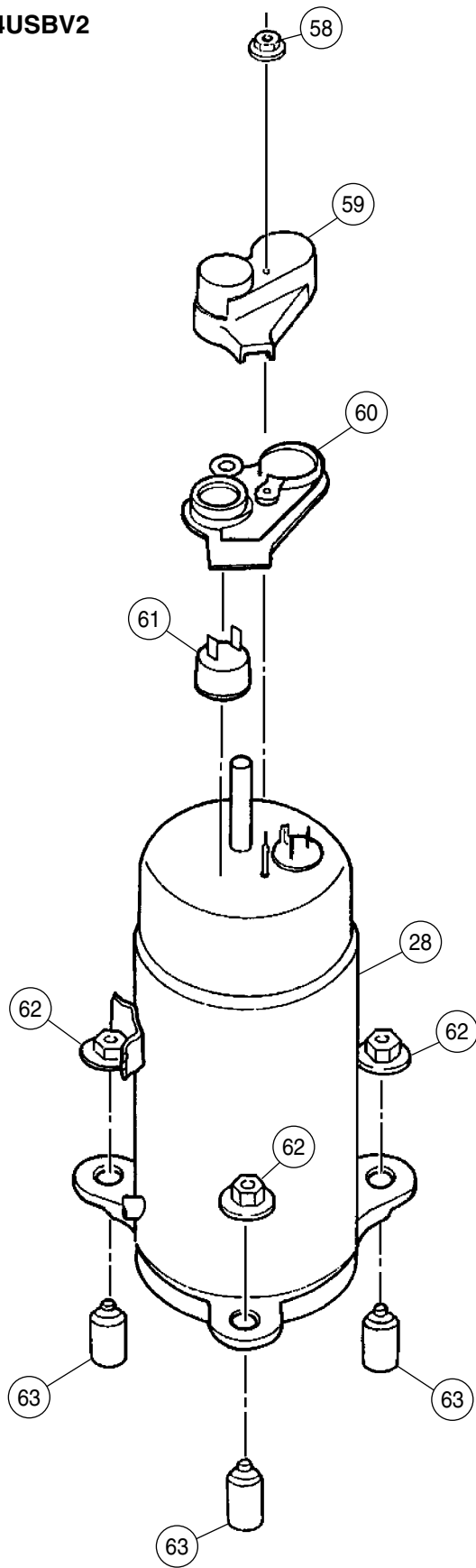

# PARTS LIST

## INDOOR UNIT

Ref. No.	Description	Part No.	Ord.
		<b>ASH12UMBD</b>	Q'ty
34	Capacitor (Fan Motor)	9900089061	
63	Front Panel Assy	9312172085	
65	Flow Control Panel-Z	9306058043	
69	Louver-A	9306055028	
74	Filter	9305444014	
108	Base	9309755062	
109	Casing Assy	9312173037	
122	Shaft Holder-B	9303066010	
127	Drain Hose Assy	9305550029	
146	Evaporator Assy	9373044017	
151	Control Box	9330007017	
158	Connecting Pipe Assy	9306416010	
164	Fan Motor Assy-IN	9601844013	
169	Cross-Flow Fan Assy	9307836015	
184	Thermistor Spring	313728262708	
196	Clamp SKB-150	313035356905	
233	Power Transformer	9900028015	
236	Controller PCB Assy	9705536050 (K03BK-0502HSE-C1)	
240	Remote Control Unit	9314684029	
281	Clamp Metal (Pipe)	9306063009	
283	Bushing-A	9303529010	
323	Louver-B	9306056025	
385	Indicator PCB Assy	9705296015	
401	Wall Hook Bracket	9304358008	
440	Flow Control Panel-U	9306057046	
522-1	Gear-A	9306062002	
523	Gear Bracket	9306407001	
652-1	Thermistor Holder Pipe	313714262805	
759-1	Intake Grille-B	9330002012	
764	Drain Cap Assy	9304150008	
767-1	Bottom Cover	9330004016	
777	Clamper (Grille)	9306755010	
815	Terminal	9900040055	
850	Window (Receiver)	9330003019	
872	Indicator Case	9330009011	
873	Lamp Cover	9330014015	
874	Control Box Cover	9330008014	
875	Power Supply PCB Assy	9705294011	
876	Step Motor	9900139018	
962-1	Guard Holder-L	9306678012	
962-2	Guard Holder-R	9306677015	

## INDOOR UNIT

Ref. No.	Description	Part No.	Ord. Q'ty	Ref. No.	Description	Part No.	Ord. Q'ty
		AUH12UMAB				AUH12UMAB	
64	Capacitor (FanMotor)	9900284015		465	Body-B	9359645009	
67	Rubber (Vibration-proof)	9361279001		467	Drain Port	313005415658	
127	Drain Hose	9359659013		468	Special Nut-A (Large)	313005446653	
138	Special Wall-A	9359647003		469	Special Nut-B (Small)	313005446759	
146	Evaporator Assy	9373214014		470	Separate Wall-B	9359648000	
160	Drain Pan	9359651000		474	Turbo Fan	9359658009	
164	Fan Motor Assy-In	9601040019		475	Cushion(Turbo Fan)	9366013006	
184-1	Thermo. Spring-A	313728262708		476-3	Special Washer	9359954002	
185	Rubber Bushing	313005066051		478	Sensor M. Bracket	9359654001	
187	Clamp No. 1219	313361271706		484	Hanger Metal	9359644002	
196	Clamp SKB-150	313035356905		488	Drain Pan Plug	9359653004	
223	Control Box	9359661016		495	Clamp No. 2U46	9352715006	
234	Thermistor Assy-Room	9703299032		514	Control Box Cover	9359662006	
235	Thermistor Assy-Pipe	9703297014		628	Locking Spacer-B	313005446558	
236	Control PCB Assy (EZ-0032EHSE-C)	9704557605		652-1	Thermistor Holder Pipe	313806262805	
240	Remocon Assy	9371190037		743	Remocon Holder	9305642014	
244	Pipe Cover	9359646006		797	Separate Wall-C	9359649007	
287	Cap (Power)	9352173011		798	Pump Hook Bracket	9359650003	
301	Clamp NK-2N	313985355201		815	Terminal-3P	9900203016	
313	Hooking Wire	9359983002		824-3	Fuse	0600222512	
338	Motor Fixture	9359656005		834	Wire Cover	9359878001	
381	Locking Spacer	313209391506		835	Cushion-A (For Pump)	9352211003	
395	Eva Holder	9373179016		836	Cushion-B (For Pump)	9356084016	
399	Air Duct	9359660002		875	Filter PCB Assy	9704561046	
411	Supporter-A	9359655008		965	Flare Nut-B	9351062019	
430	Clamp NK-7N	313095365602		989-1	Cord Clamp-A	9359822011	
457	Drain Pan Support	9359652007		989-2	Cord Clamp-B	9359823018	
462	Top Cover Plate	9359642015		990	Distributor Assy	9373034049	
464	Body-A	9359643005					

## GRILLE ASSY ( UTG-UDGD-W )

Ref. No.	Description	Part No.	Ord. Q'ty	Ref. No.	Description	Part No.	Ord. Q'ty
93	Filter	9359632009		692	Joint Shaft	9359625001	
165	Motor Cover	9359623014		694	Cam Gear	9359628002	
196	Clamp SKB-150	313035356905		700	Panel	9359619017	
226	Motor Gear	9359629009		705	Louver	9374951017	
385	Indicator PCB Assy	9702224011		710	Intake Grille	9370126006	
392	Cover-A	9359622017		711-1	Filter Clamp-A	9359634003	
416	Insulation (Panel)-A	9359620006		711-2	Filter Clamp-B	9359635000	
417	Insulation (Panel)-B	9359621003		758	Decoration Plate-A	9360039026	
690	Joint-A	9359626008		763	Receiver Cover	9359630005	
691	Joint-B	9359627005		776	Grille Stopper	9359633013	
				777	Grille Hook	9359761006	
				876-2	Step Motor	9900362027	







## OUTDOOR UNIT



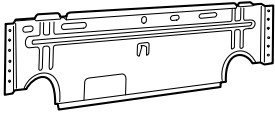
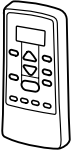

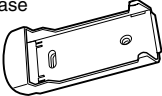
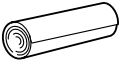

Ref. No.	Description	Part No.	Ord. Q'ty
		AOY24USBV2	
1	Top Panel Sub Assy	9374417018	
2	Front Panel S	9374094080	
3	Fan Guard	9374330010	
4	Grip Side	9374173013	
5	Service Panel Sub Assy	9374415045	
6	Right Panel	9374599042	
9	Grip	9374172016	
10	Print Net S	9374255047	
11	Propeller Fan Assy	9366378013	
12	Motor, Induction	9601671060	
13	Condenser A Assy	9374433094	
14	Separate Wall S	9374135042	
15	Base Assy	9374166121	
18	Cap Foot	9374345014	
19	Motor Bracket Sub Assy	9374418084	
23	Compressor Cover A	9375323011	
24	Compressor Cover B	9374431076	
25	Compressor Cover C	9372067055	
27	Compressor Plate Assy	9375221027	
28	Compressor Assy	9373010036	
29	4-Way Valve A Assy	9375293017	
30	4-Way Valve B Assy	9375294014	
31	3-Way Valve Assy	9375103019	
32	2-Way Valve Assy	9375102012	
33	Solenoid (A=White)	9900165079	
34	Solenoid (B=Red)	9900165062	
35	Inlet Pipe (Cond) A1 Assy	9373461081	
36	Inlet Pipe (Cond) B1 Assy	9373463061	
37	Outlet Pipe (Cond) A Assy	9374266098	
38	Outlet Pipe (Cond) B Assy	9375292010	
39	Capillary A Assy	9375297015	
40	Capillary B Assy	9375298012	
41	Joint Pipe (Valve) A Assy	9375295011	
42	Joint Pipe (Valve) B Assy	9375296018	
46	PCB Assy	9707096019	
47	Band (Capacitor)	9352123009	
48	Capacitor, Plastic (Comp.)	9900269036	
49	Capacitor, Plastic (Fan)	9900270049	
50	Relay	9900264017	
51	Terminal	9900203047	
52	Clamp (Cord) C	9359677000	
53	Clamp (Cord)	9356857009	
54	Clamp No.1219	313361271706	
55	Wire Clamper	0600231019	
56	Clip (Cable) No 1259	313739340109	
57	Thermistor Assy	9900356019	
58	Special Nut M5	313199233602	
59	Terminal Cover (Comp)	9351120009	
60	Terminal Gasket (Comp)	9351121006	
61	OCR Assy	9312899005	
62	Special Nut	9355091008	
63	Rubber Seat (Comp)A	9351813017	
---	Emblem Rear	9372171011	

# STANDARD ACCESSORIES

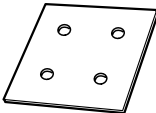
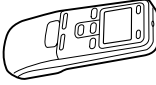

## INDOOR UNIT ACCESSORIES (ASH12UMBD)

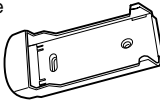
Name and Shape	Q'ty	Part No.
Wall hook bracket 	1	9304358008
Remote control unit 	1	9314684029 (AR-JE5)
Battery (penlight) 	1 set	0600185534
Remote control unit holder case 	1	9312653010
Cloth tape 	1	9310519004
Tapping screw (big) ( $\phi 4 \times 25$ ) 	8	0700076046
Tapping screw (small) ( $\phi 3 \times 12$ ) 	2	0700019036

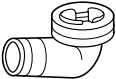

## INDOOR UNIT ACCESSORIES (AUH12UMAB)

Name and Shape	Q'ty	Part No.
Coupler heat insulation 	1	9350716029
	1	9352766015
Special nut A (large flange) 	4	313005446653
Special nut B (small flange) 	4	313005446759
Template 	1	9360256003
Remote control unit 	1	9371190037
Battery (penlight) 	1 set	0600185534
Remote control unit holder case 	1	9305642014
Tapping screw ( $\phi 3 \times 12$ ) 	3	0700019098

## OUTDOOR UNIT ACCESSORIES (AOH24USBV2)

Name and Shape	Q'ty	Part No.
Putty 	1	303020200114
Drain pipe 	1	9303029015
Drain cap 	2	313166024302

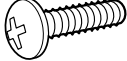
## GRILLE ASSY ACCESSORIES

Name and Shape	Q'ty	Part No.
screw ( $\phi 5 \times 24$ ) 	4	0700139116
Washer 	4	301801155020
Blower cover insulation 	2	9360047007

0601G3003