



**INVERTER MULTI
AIR CONDITIONER
DUCT type**

**SERVICE
MANUAL**



Models

Indoor unit	Outdoor unit
ARH9LUAB	AOH30LMAW4

CONTENTS

SPECIFICATIONS	1
OUTLINE AND DIMENSIONS	3
REFRIGERANT SYSTEM DIAGRAM	5
CIRCUIT DIAGRAM	6
INDOOR PCB CIRCUIT DIAGRAM	8
OUTDOOR PCB CIRCUIT DIAGRAM	9
ERROR CONTENTS	12
DISASSEMBLY ILLUSTRATION	13
PARTS LIST	21

SPECIFICATIONS

INDOOR UNIT

TYPE	Cool and Heat
MODEL NAME	ARH9LUAB

ELECTRICAL DATA

POWER SOURCE	(V)	230
FREQUENCY	(Hz)	50
AIR CIRCULATION-Hi	(m ³ /hr)	450

FAN MOTOR

DISCRIMINATION	MFA-9NTAT	
POWER SOURCE	(V)	230
HI-SPEED	(r.p.m.)	955
MED-SPEED	(r.p.m.)	870
LO-SPEED	(r.p.m.)	800

DIMENSIONS	H x W x D	(mm)	217 x 663 x 595
WEIGHT	GROSS / NET	(kg)	22 / 18

OUTDOOR UNIT

TYPE	Colling & Heating	
MODEL NAME	AOH30LMAW4	
COOLING CAPACITY	(kW)	8.0
HEATING CAPACITY	(kW)	9.6

ELECTRICAL SPECIFICATIONS

POWER SUPPLY	(V)	(220) - 230 - (240)	
FREQUENCY	(Hz)	50	
RUNNING CURRENT	(A)	COOLING	9.7
		HEATING	10.5
INPUT	(kW)	COOLING	2.22
		HEATING	2.40
EER	(kW/kW)	COOLING	3.60
		HEATING	4.00
AIR CIRCULATION - Hi	(m ³ /hr)	3,300	

COMPRESSOR

TYPE	Hermetic type, Inverter, 4 poles, 3-phase, DC motor, Twin Rotary		
DISCRIMINATION	TNB220FPBM9		
REFRIGERANT	R410	(g)	3,300

FAN MOTOR

DISCRIMINATION	MFE-60PO	
HI-SPEED (COOL/HEAT)	(r.p.m.)	820 / 780

DIMENSIONS	H x W x D	(mm)	830 x 900 x 330
WEIGHT	NET / GROSS	(kg)	68 / 78

REFRIGERANT CHARGE (R410A)

FULL CHARGE AMOUNT	Total Pipe Length	50.0 m	3,300 g
		60.0 m	3,550 g
		70.0 m	3,800 g
ADDITIONAL CHARGE			25 g / m
CHARGELESS			50 m
MAX PIPE LENGTH (each unit)			25 m
MAX PIPE LENGTH (total)			70 m
MAX ELEVATION (between indoor units)			10 m
MAX ELEVATION (between indoor and outdoor units)			10 m
MIN. PIPE LENGTH (each unit)			5 m

OUTLINE AND DIMENSIONS

(unit : mm)

INDOOR UNIT

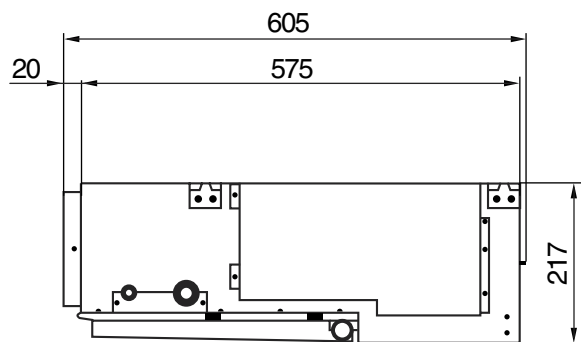
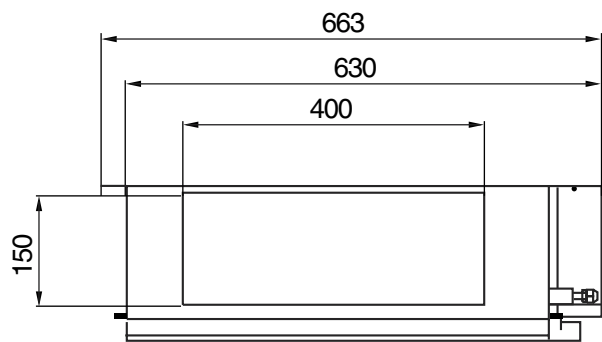
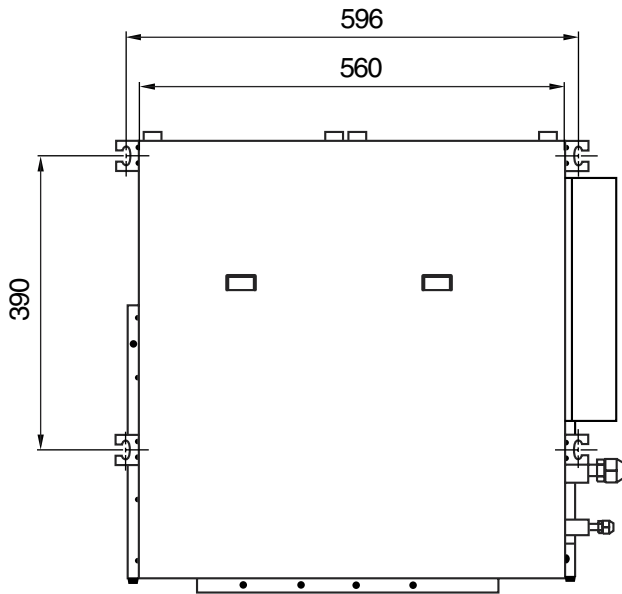

OUTDOOR UNIT (Unit : mm)

Model : AOH30LMAW4

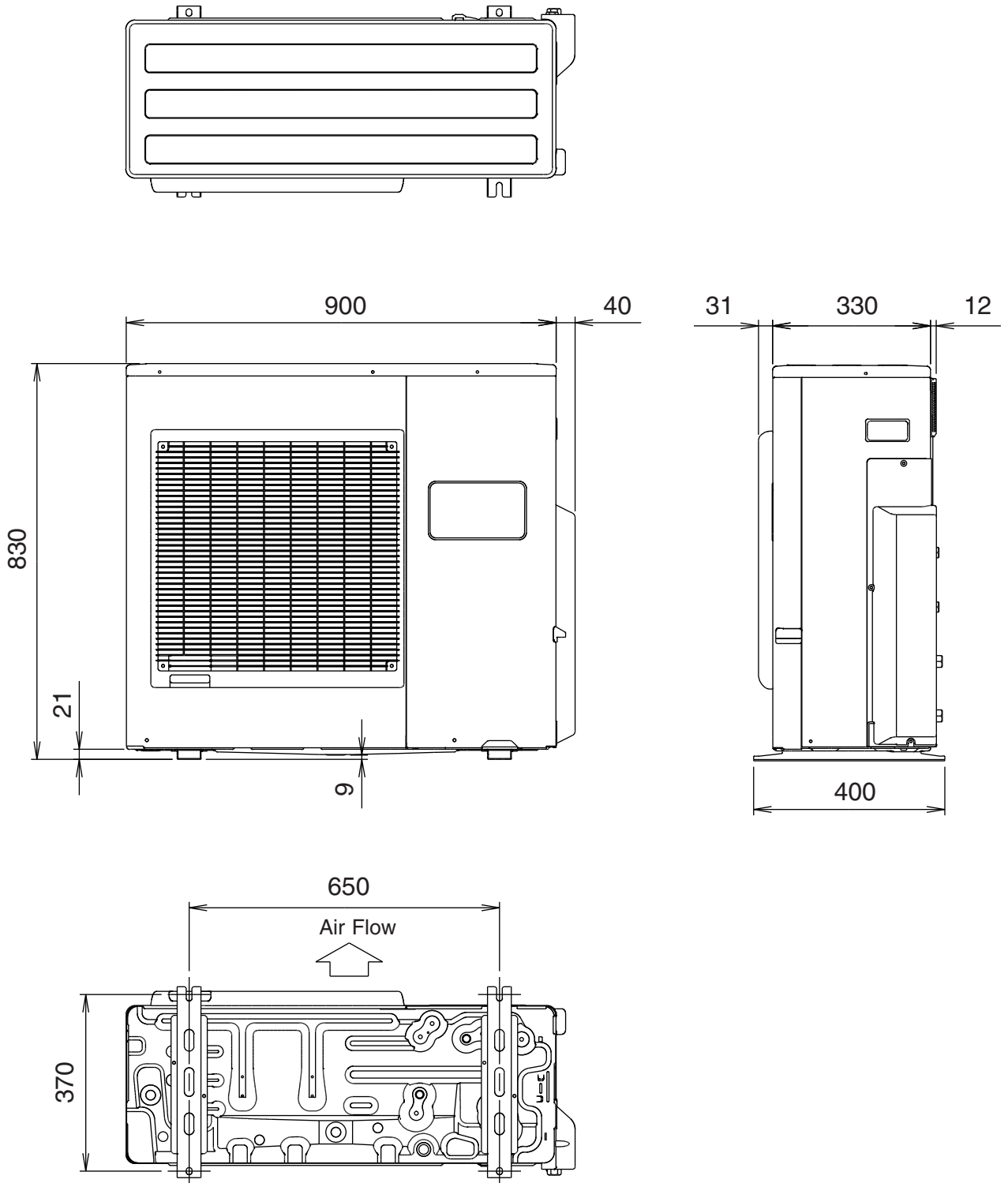

REFRIGERANT SYSTEM DIAGRAM

Outdoor unit

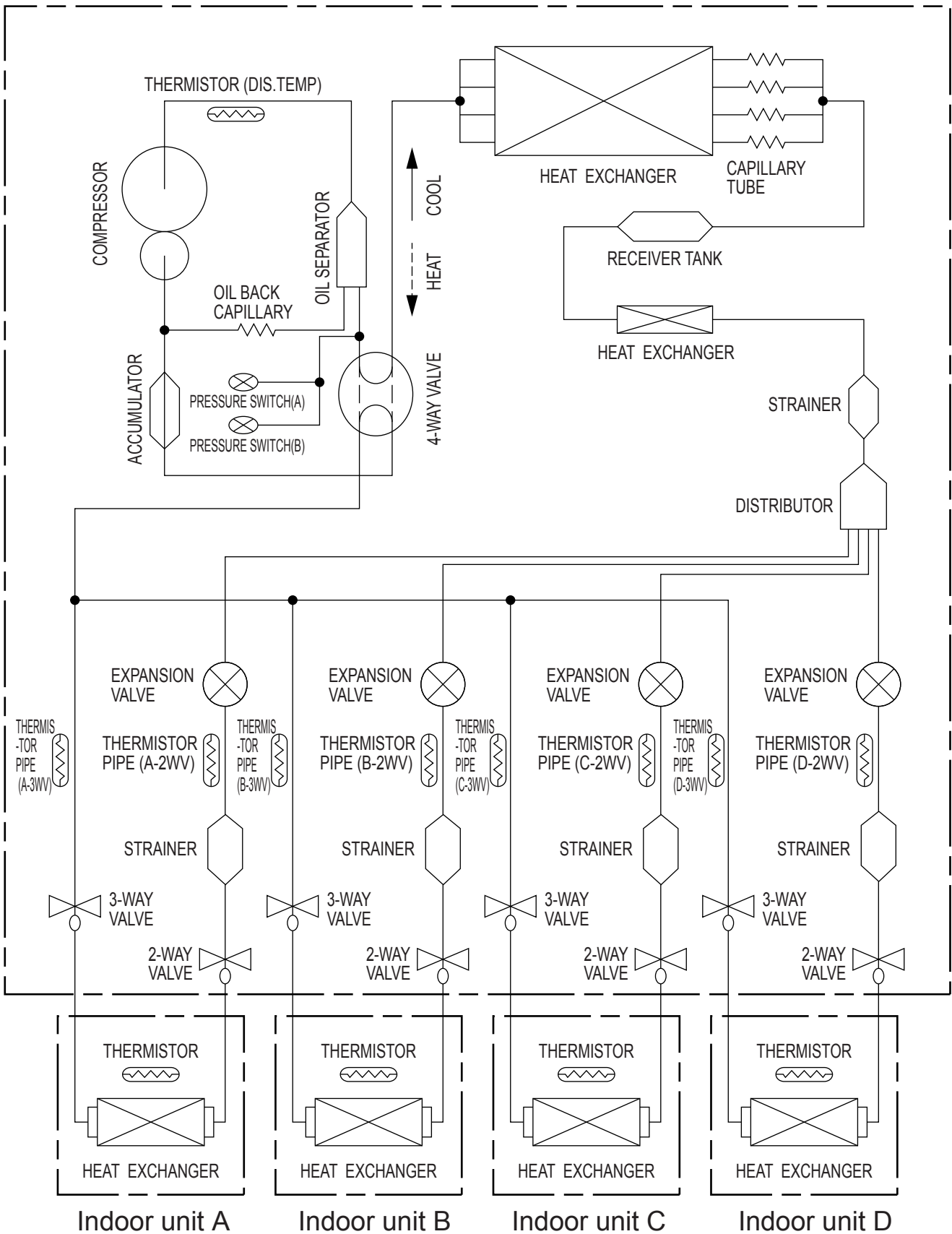

CIRCUIT DIAGRAM

Model : ARH9LUAB

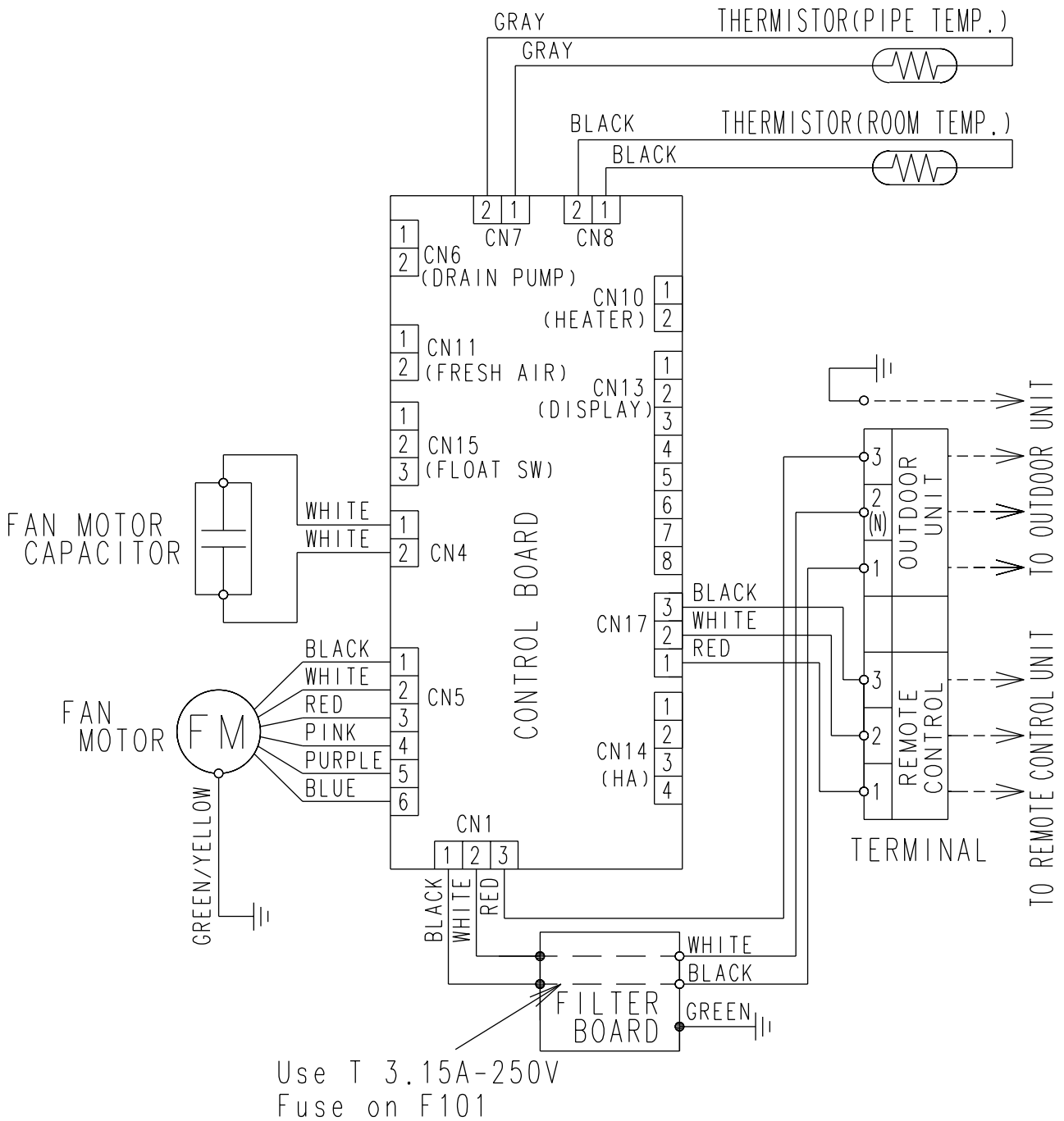

Model : AOH30LMAW4

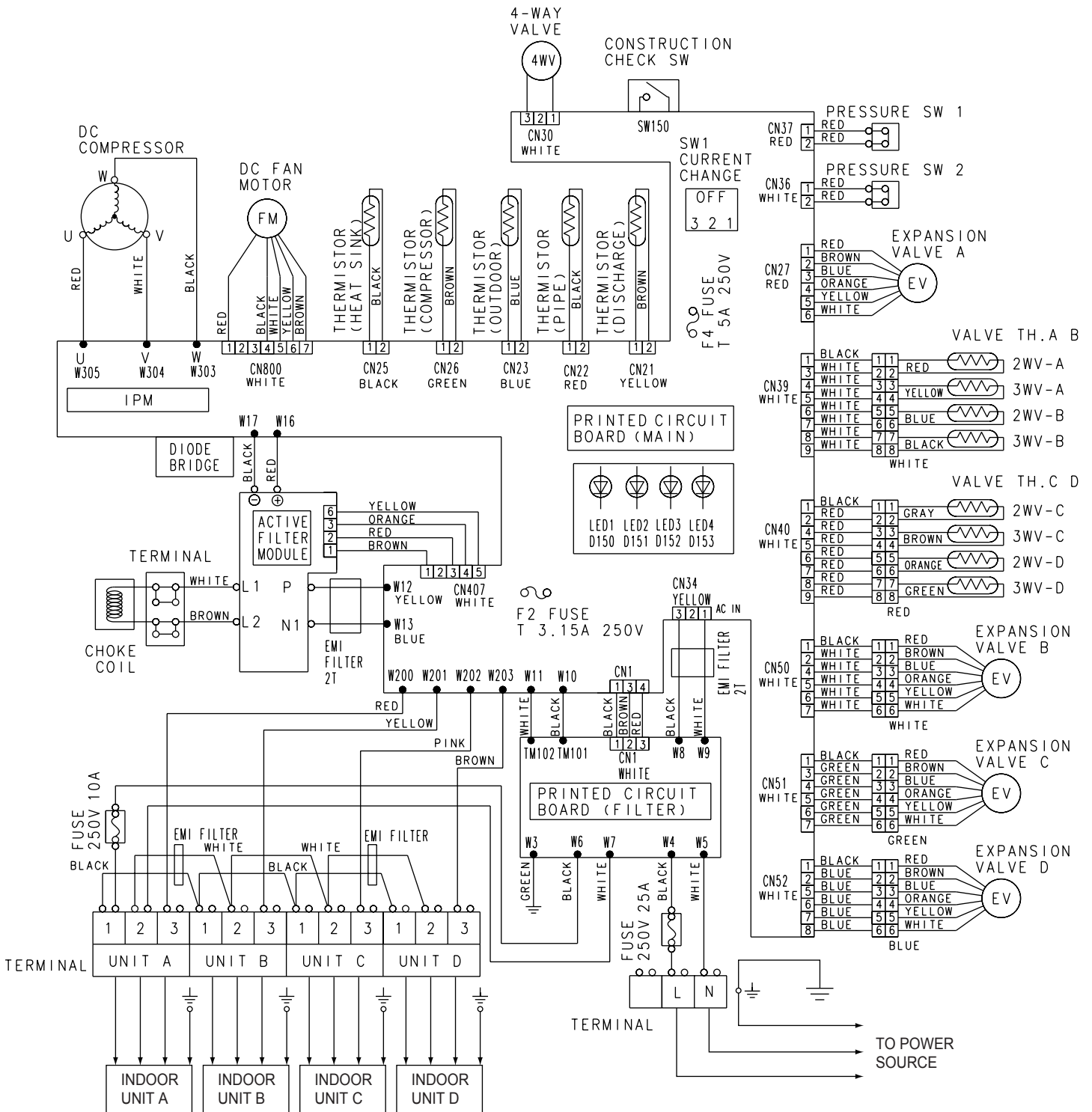

INDOOR PCB CIRCUIT DIAGRAM

Model : ARH9LUAB

CONTROLLER PCB ASSEMBLY (MAIN PCB)

K01AL-0413HSE-C1

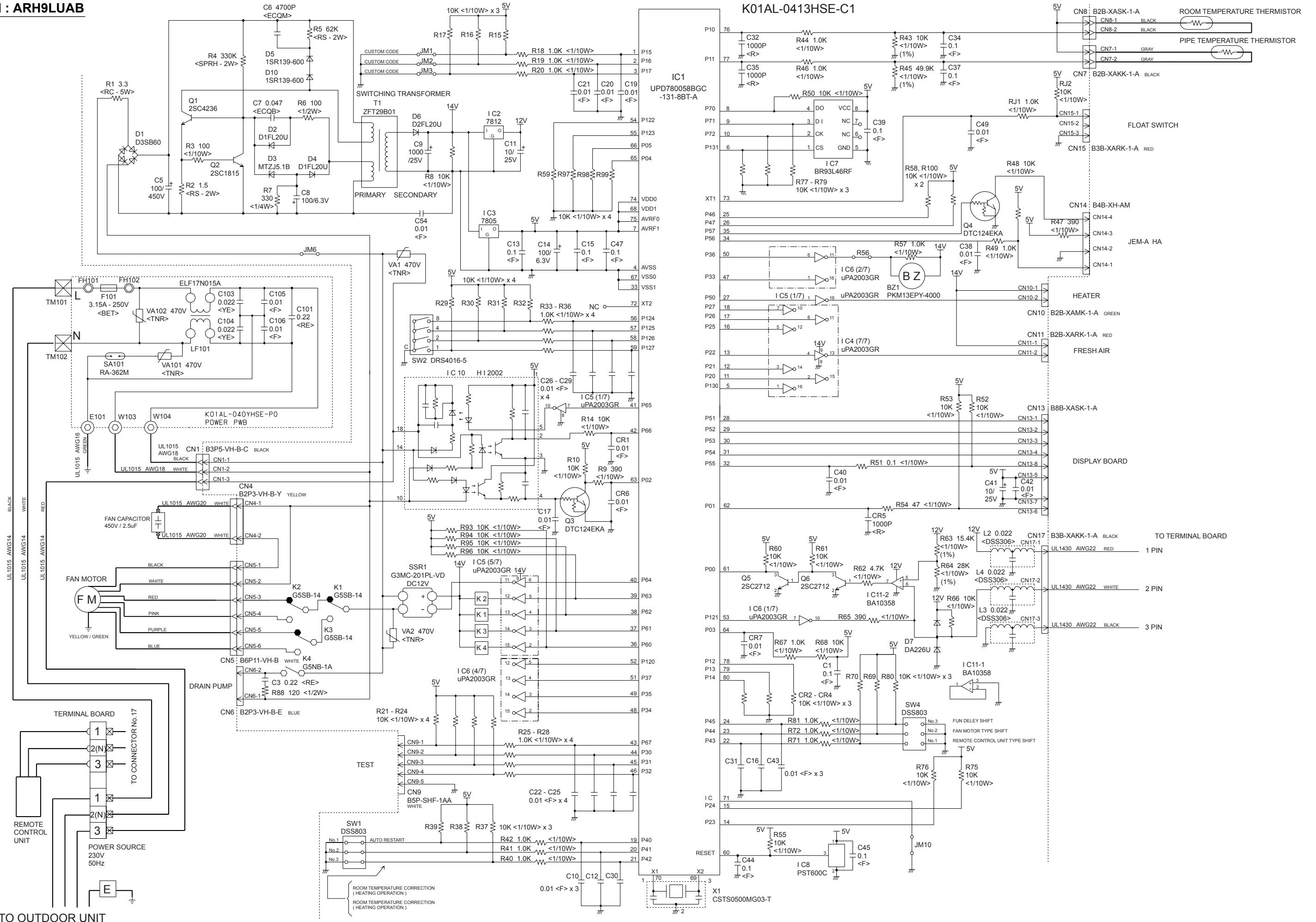

OUTDOOR PCB CIRCUIT DIAGRAM

Model : AOH30LMAW4

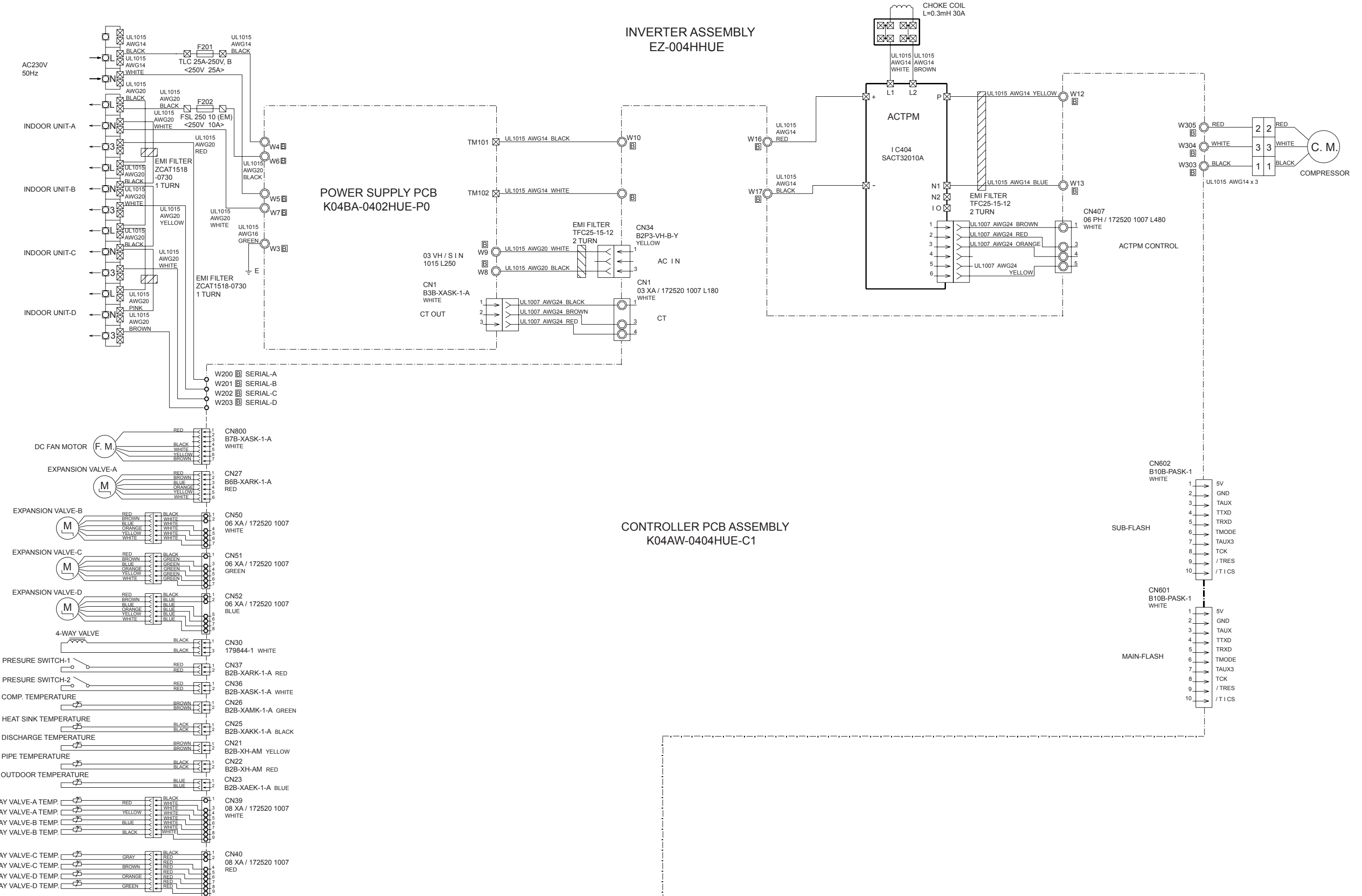

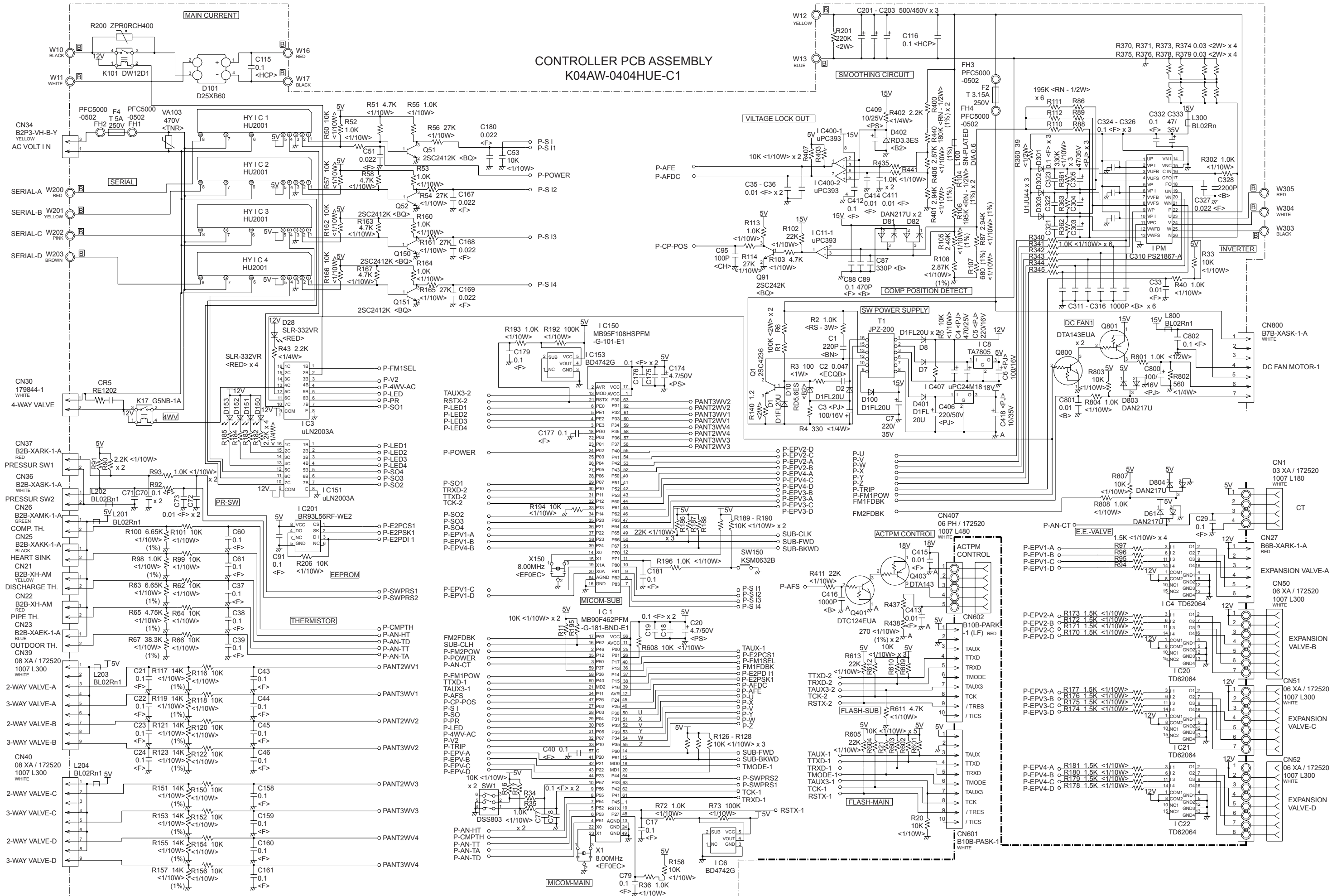

CONTROLLER PCB ASSEMBLY
K04AW-0404HUE-C1

Model : AOH30LMAW4

**POWER SUPPLY PCB ASSEMBLY
K04BA-0400HUE-P0**

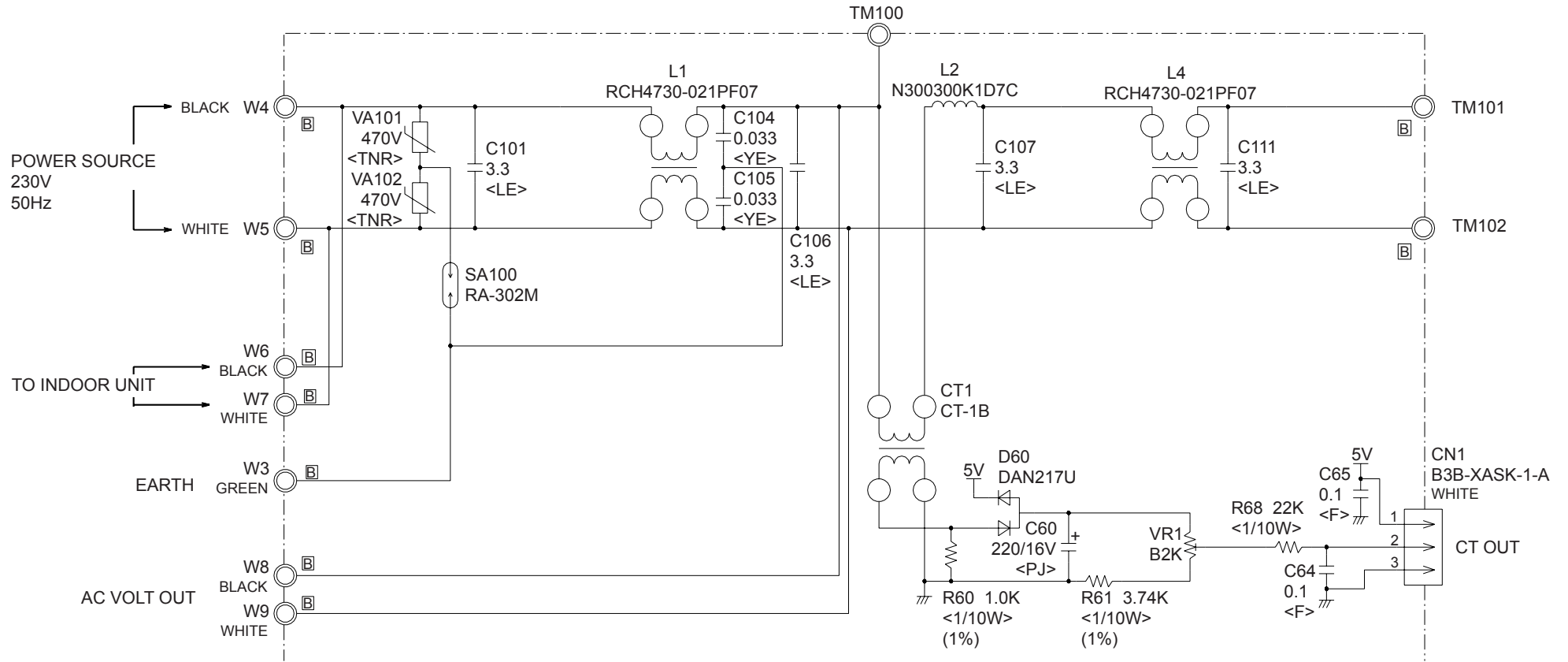

ERROR CONTENTS

- (1) Stop the air conditioner operation.
- (2) Press the master control button and the fan control button simultaneously for 2 seconds or more to start the test run.

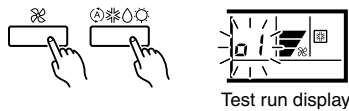

- (3) Press the start/stop button to stop the test run.

[SELF-DIAGNOSIS]

When the error indication "E:EE" is displayed, follow the following items to perform the self-diagnosis. "E:EE" indicates an error has occurred.

1. REMOTE CONTROLLER DISPLAY

- (1) Stop the air conditioner operation.
- (2) Press the set temperature buttons \wedge / \vee simultaneously for 5 seconds or more to start the self-diagnosis. Refer to the following tables for the description of each error code.

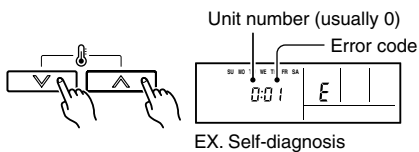

- (3) Press the set temperature buttons \wedge / \vee simultaneously for 5 seconds or more to stop the self-diagnosis.

Error code	Error contents
00	Communication error (indoor unit \longleftrightarrow remote controller)
01	Communication error (outdoor unit \rightarrow indoor unit)
02	Room temperature sensor open
03	Room temperature sensor short-circuited
04	Indoor heat exchanger temperature sensor open
05	Indoor heat exchanger temperature sensor short-circuited
06	Outdoor heat exchanger temperature sensor
08	Power source connection error
09	Float switch operated
0A	Outdoor temperature sensor
0c	Discharge pipe temperature sensor
11	Model abnormal
12	Indoor fan abnormal
13	Outdoor signal abnormal
14	Outdoor EEPROM abnormal
15	Compressor temperature sensor
16	Pressure switch abnormal
17	IPM error
1A	Compressor cannot operate
1b	Outdoor fan abnormal

DISASSEMBLY ILLUSTRATION

Model : ARH9LUAB

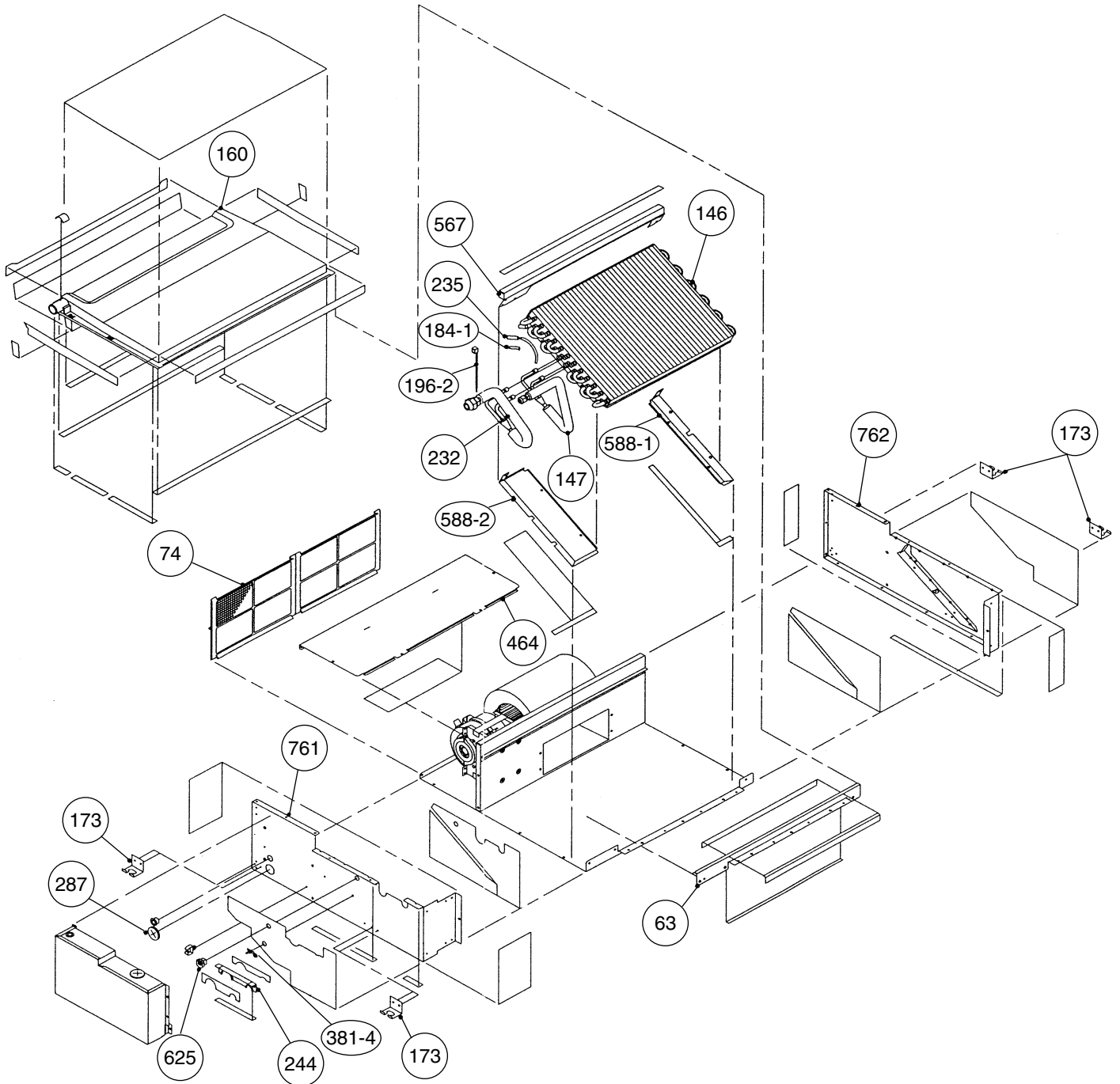

Model : ARH9LUAB

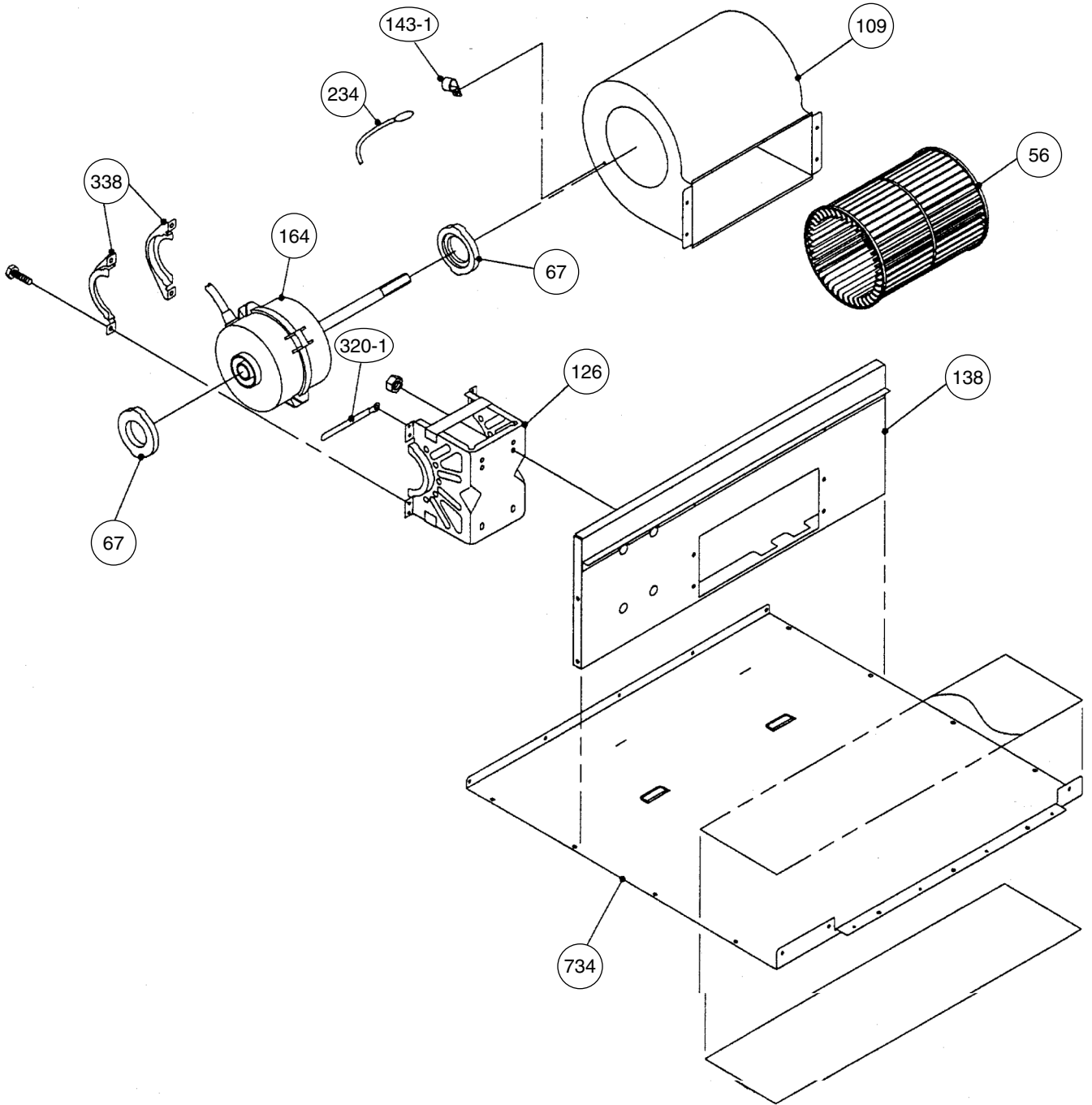

Model : ARH9LUAB

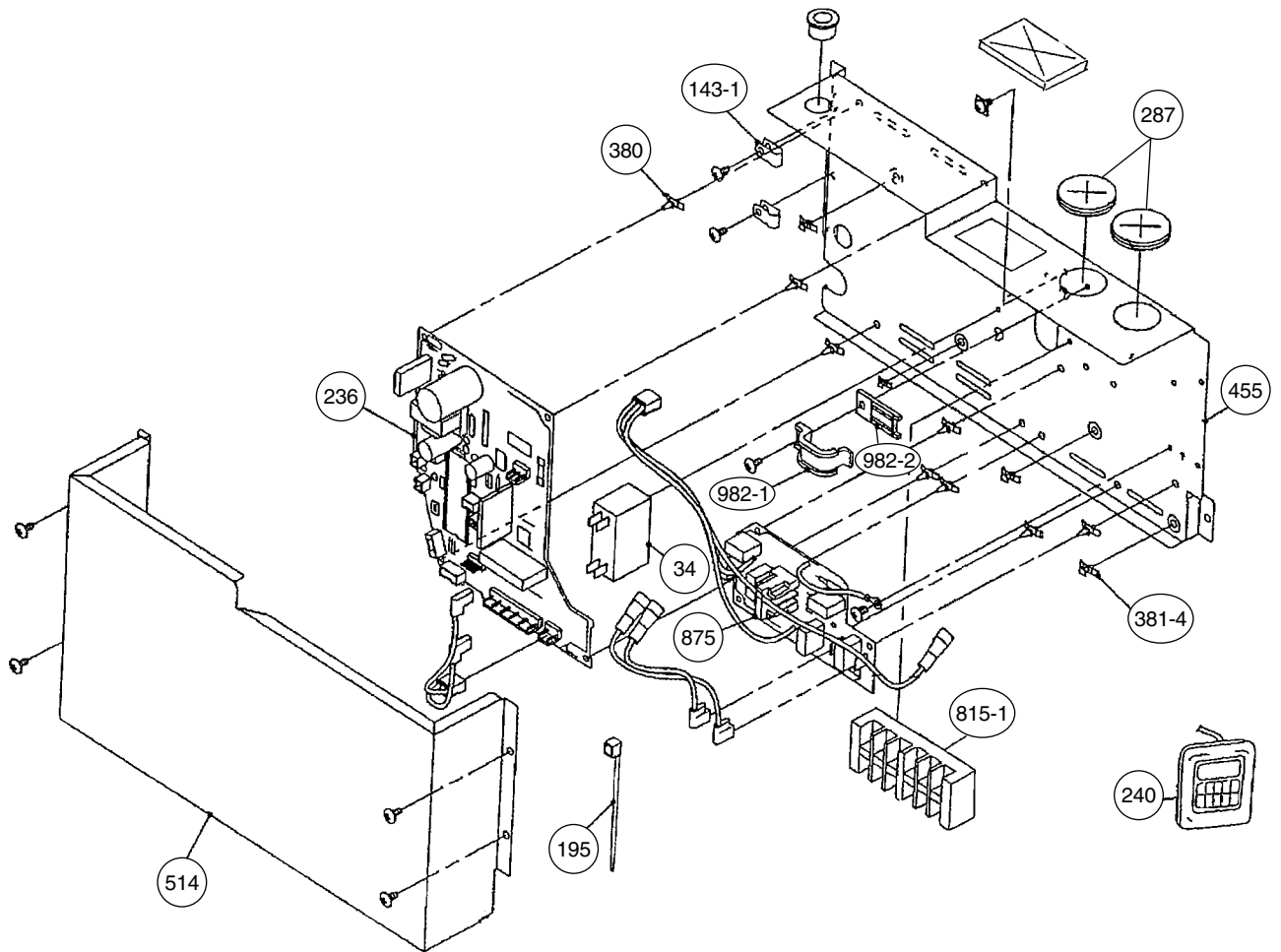

Model : AOH30LMAW4

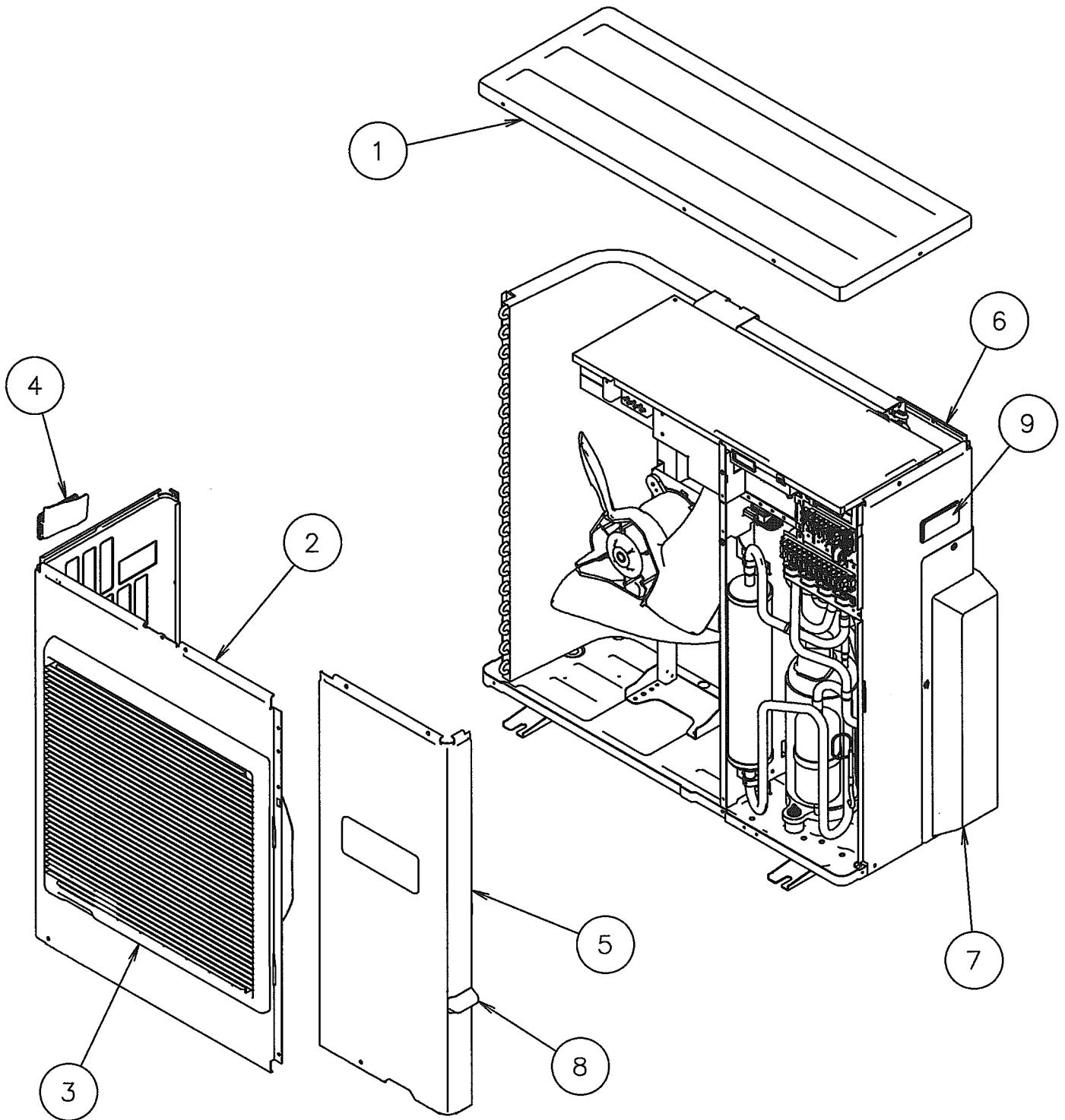

Model : AOH30LMAW4

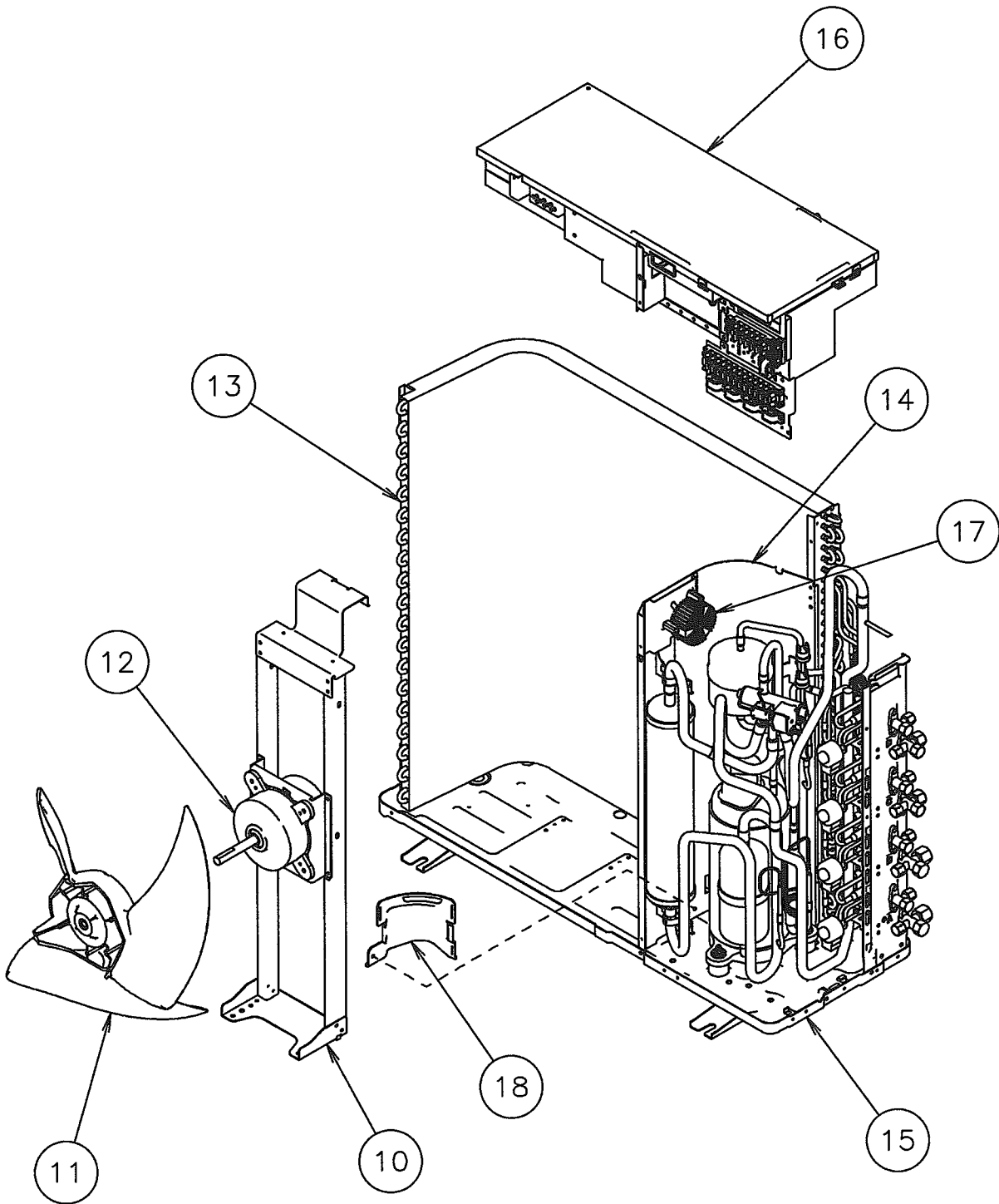

Model : AOH30LMAW4

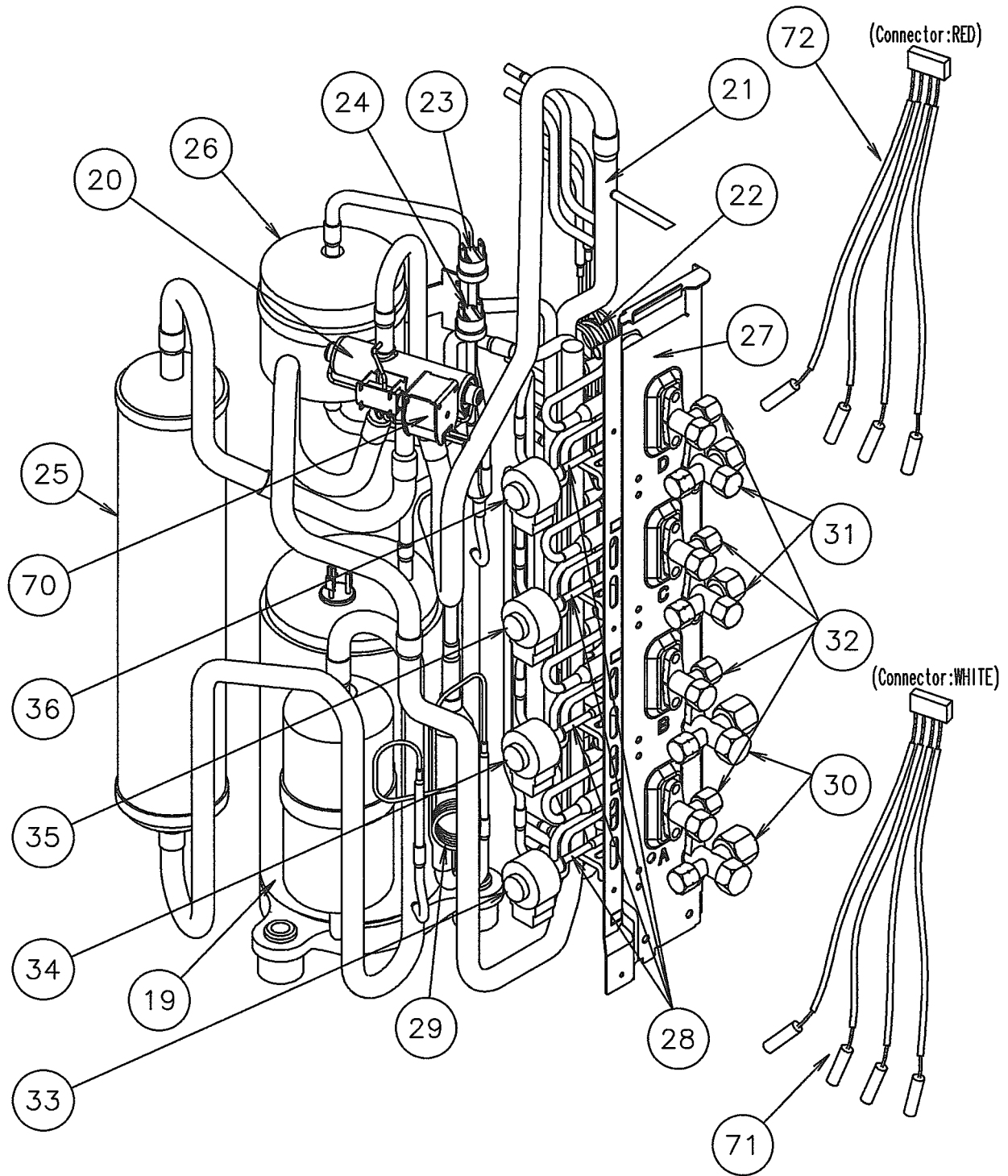

Model : AOH30LMAW4

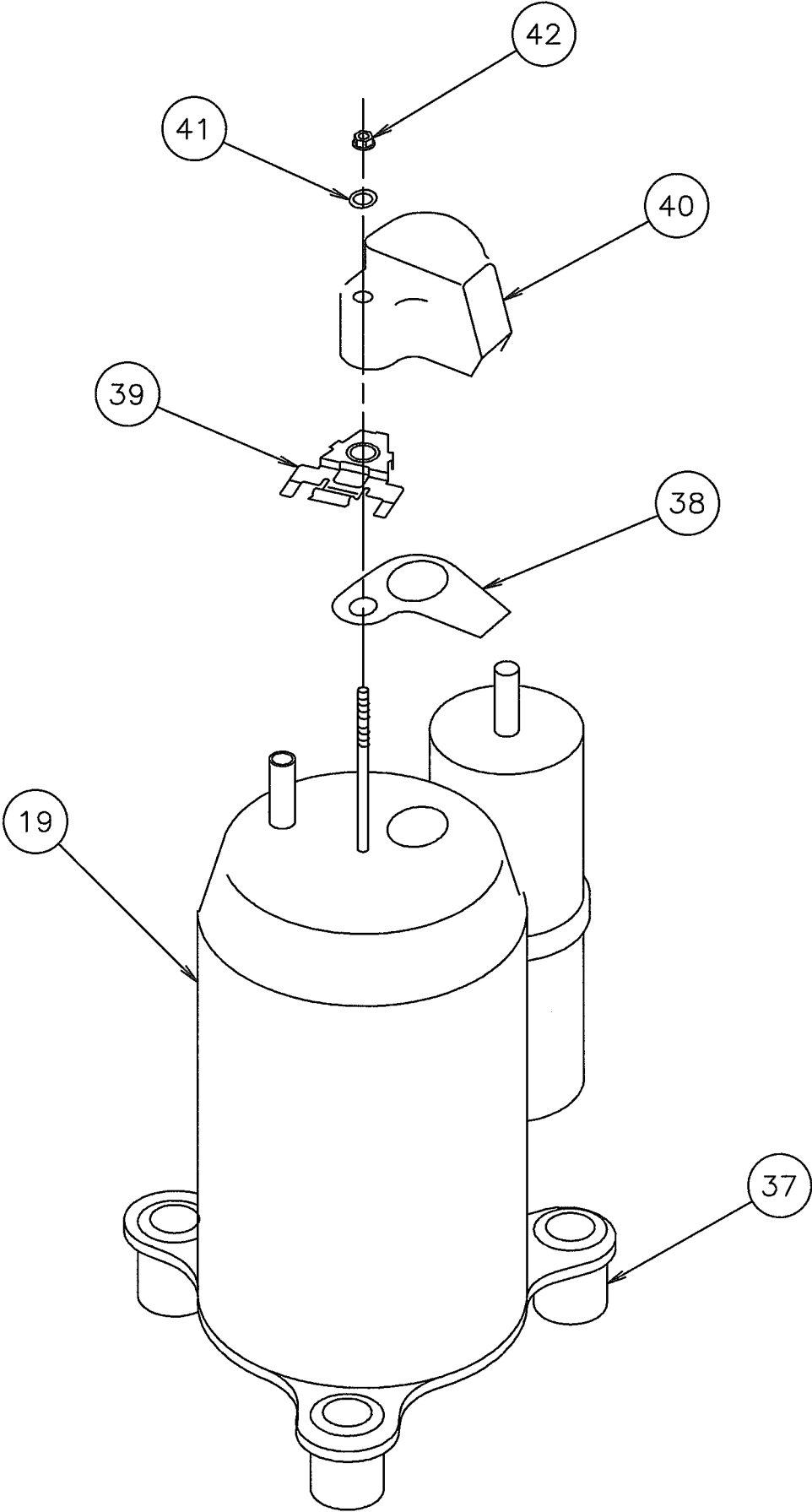

Model : AOH30LMAW4

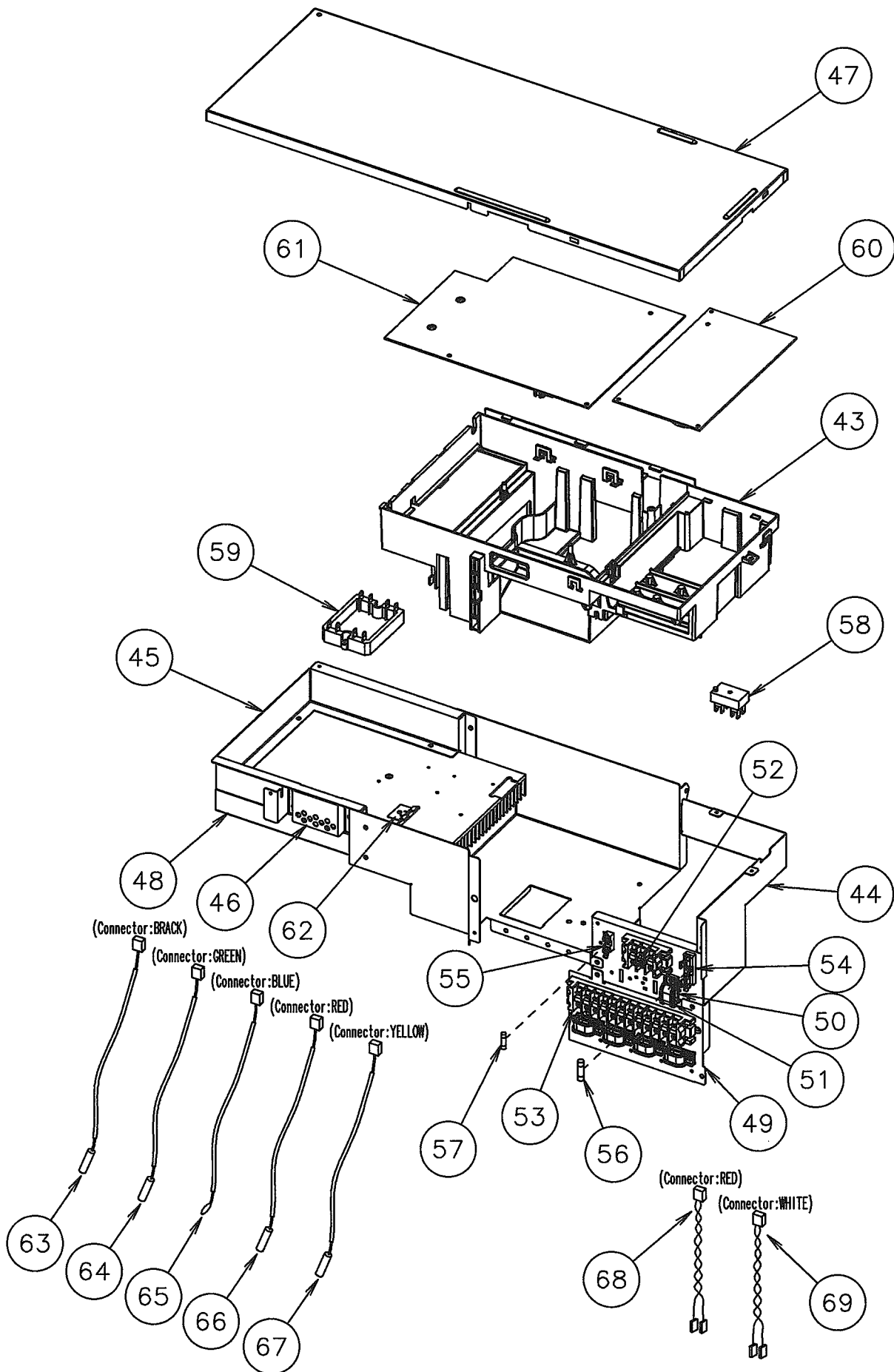

PARTS LIST

INDOOR UNIT











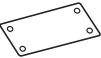

Ref. No.	Description	Part No.	Ord. Q'ty
		ARH9LUAB	
34	Fan Capacitor	9900270186	
56	Sirocco Fan Assy	9358621004	
63	Panel Assy Front	9363722000	
67	Rubber (Vibration-proof)	313659068604	
74	Air Filter	9366833017	
109	Casing Assy	9363322002	
126	Bracket (Motor) Assy	9358591000	
138	Panel Assy (Motor)	9363193008	
143-1	Clamp NK-3N	313361274700	
146	Evaporator Assy	9373255031	
147	Distributor Assy	9373034070	
160	Drain Pan Sub Assy	9364502014	
164	Motor, Induction	9600778203	
173	Hook Metal	9363195002	
184-1	Thermostat Spring-A	313728262708	
195	Binder-C (SKB-100)	313361275805	
196-2	Binder-M (SKB-150)	313035356905	
232	Coupling Pipe Assy	9373038078	
234	Thermistor (Room)	9703299063	
235	Pipe Thermistor	9703297090	
236	Controller PCB Assy	9704557995 (K01AL-0413HSE-C1)	
240	Remote Control Unit	9372266014	
244	Cover (Piping)	9363330007	
287	Cap (Power)	9352173011	
320-1	Wire Clamp Metal	313483219905	
338	Bracket (Motor)	9358594001	
380	Locking Spacer KGLS-6S	313209391403	
381-4	Spacer KGPS-6S	0600118075	
455	Control Box	9366299004	
464	Cabinet Cover Sub Assy	9364503011	
514	Control Box Cover	9363201000	
567	Support Plate (Eva.)	9363323009	
588-1	Bracket Eva. R	9363199000	
588-2	Bracket Eva. L	9363198003	
625	Cord Bush	9359240006	
734	Top Panel Sub Assy	9364507019	
761	Side Panel Right Sub Assy	9364505015	
762	Side Panel Left Sub Assy	9364506012	
815-1	Terminal 7P	9703403019	
875	Filter PCB Assy	9704561251	
982-1	Clamp (Cord)	9356857009	
982-2	Clamp (Cord)-B	9356858006	

OUTDOOR UNIT

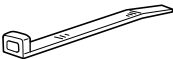





Ref. No.	Description	Part No.	Ord. Q'ty	Ref. No.	Description	Part No.	Ord. Q'ty
		AOH30LMAW4				AOH30LMAW4	
1	Top Panel Sub Assy	9374417025		41	Washer (Rubber)	9358078006	
2	Front Panel M	9374094066		42	Frang Nut	9358079003	
3	Fan Guard	9374330010		43	Inverter Box A	9374603015	
4	Grip Side	9374173013		44	Inverter Box B Assy	9374625017	
5	Service Panel M	9374093069		45	Inverter Box C	9374605019	
6	Right Panel M	9374599028		46	Inverter Box Duct	9374609017	
7	Valve Cover Sub Assy	9374827015		47	Inverter Box Cover	9374608010	
8	Grip Service	9374171019		48	Heat Sink A	9374607013	
9	Grip	9374172016		49	Inverter Box D	9374606016	
10	Motor Bracket Sub Assy	9374418053		50	Clamp (Cord) C	9359677000	
11	Propeller Fan Assy	9366378020		51	Clamp (Cord)	9356857009	
12	Motor. DC Brushless	9601882015		52	Terminal (3P)	9900203016	
13	Condenser A Assy	9374433056		53	Terminal (12P)	9358660164	
14	Separate Wall Assy S	9374629022		54	Fuse Holder (Big)	0501454012	
15	Base Assy	9374166084		55	Fuse Holder (Small)	0501456016	
16	Inverter Assy	9705824010		56	Fuse (Big)	0600086039	
17	Coil. Choke	9703458019		57	Fuse (Small)	0600376116	
18	Cap Foot	9374345014		58	Terminal	9701971015	
19	Compressor Sub Assy	9374423064		59	ACTPM	9703457012	
20	4-Way Valve Assy	9374425044		60	PWB Assy (Power Supply)	9705647039	
21	Inlet Pipe (Cond) A Assy	9373461067		61	PWB Assy (Controller)	9705642058	
22	Outlet Pipe (Cond) A Assy	9374266067		62	Holder (Thermo)	9372797013	
23	Pressure Switch A Assy	9367726028		63	Heat Sink Thermistor	9900311018	
24	Pressure Switch B Assy	9367727025		64	Compressor Temp Thermistor	9900156022	
25	Accumulator Sub Assy	9374426072		65	Thermistor (Outdoor Temp)	9703516078	
26	Receiver Tank Sub Assy	9373426028		66	Heat Exchanger Thermistor	9704220059	
27	Valve Plate A Assy	9374628025		67	Discharg Temp Thermistor	9704219114	
28	Expansion Valve Assy	9370947106		68	Wire (Pressure Sw)(Red)	9367595037	
29	Capillary Assy	9372197370		69	Wire (Pressure Sw)(White)	9367595044	
30	3-Way Valve Assy (1/2")	9372205051		70	Solenoid	9900165055	
31	3-Way Valve Assy (3/8")	9372205044		71	Thermistor (Pipe)(White)	9900322014	
32	2-Way Valve Assy	9372204054		72	Thermistor (Pipe)(Red)	9900289010	
33	Coil (Expansion Valve)(A=Red)	9900057084		---	Emblem-Rear	9372171011	
34	Coil (Expansion Valve)(B=White)	9900057053					
35	Coil (Expansion Valve)(C=Green)	9900057060					
36	Coil (Expansion Valve)(D=Blue)	9900057077					
37	Rubber Seat (For Comp)	9358080009					
38	Gasket	9370290004					
39	Holder	9372066010					
40	Terminal Cover (Comp)	9370289008					

STANDARD ACCESSORIES

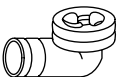
INDOOR UNIT ACCESSORIES

Name and Shape	Q'ty	Application	Parts No.
Installation template 	1	For positioning the indoor unit	9364224008
Hook metal 	4	For suspending the indoor unit from ceiling	9363195002
Tapping screw ($\phi 4 \times 10$) 	8	For installing the hanger	301171164104
Special nut A (large flange) 	4	For suspending the indoor unit from ceiling	313005446653
Special nut B (small flange) 	4		313005446759
Coupler heat insulation (large) 	1	For indoor side pipe joint (large pipe)	9350716029
Coupler heat insulation (small) 	1	For indoor side pipe joint (small pipe)	9352766015
Binder 	(Small) 1	For remote controller and remote controller cord binding	313361275805
	(Large) 4	For fixing the coupler heat insulation	312300787605
Remote control unit 	1	Heat & Cool model	9372266014
		Cool model	9372266021
Remote controller cord 	1	For connecting the remote controller	9372714010
Tapping screw ($\phi 4 \times 16$) 	2	For installing the remote controller	0700181108
Filter 	3		9366833017
Drain hose insulation 	1	Insulates the drain hose and vinyl hose connection	313806217708

OUTDOOR UNIT ACCESSORIES

Name and Shape	Q'ty	Application	Name and Shape	Q'ty	Application
Drain pipe 	1	For outdoor unit drain piping work (May not be supplied, depending on the model.)	Adapter E (1/4"→3/8") 6.35mm → 9.52mm 	1	For connecting a pipe with different diameter to the outdoor unit.
Drain cap 	2		Adapter G (1/2"→5/8") 12.7mm → 15.88mm 	1	
Putty 	1		Adapter D (1/2"→3/8") 12.7mm → 9.52mm 	2	

0504G2819