



SPLIT TYPE AIR CONDITIONER DUCT type (50Hz)

SERVICE MANUAL



Models

Indoor unit	Outdoor unit
ARH45LUAK	AOH45LJAYL
ARH45LUAK	AOH45LJBYL
ARH54LUAK	AOH54LJAYL
ARH54LUAK	AOH54LJBYL

CONTENTS

SPECIFICATIONS	1
OUTLINE AND DIMENSIONS.	2
REFRIGERANT SYSTEM DIAGRAM	4
CIRCUIT DIAGRAM.	5
PCB CIRCUIT DIAGRAM.	6
ERROR CONTENTS.	10
DISASSEMBLY ILLUSTRATION.	12
PARTS LIST.	18
STANDARD ACCESSORIES.	20

SPECIFICATIONS

TYPE	Cooling & Heating	Colling & Heating
INDOOR UNIT	ARH45LUAK	ARH54LUAK
OUTDOOR UNIT	AOH45LJAYL, AOH45LJBYL	AOH54LJAYL, AOH54LJBYL
COOLING CAPACITY	rated / max	12.5 kW / 14.0 kW
HEATING CAPACITY	rated / max	14.0 kW / 18.0 kW
		14.0 kW / 15.0 kW
		16.0 kW / 19.0 kW

ELECTRICAL SPECIFICATIONS

POWER SUPPLY	230 V		
FREQUENCY	50 Hz		
RUNNING CURRENT	COOLIING	18.9 / 22.6	23.6 / 25.9
rated / max	(A) HEATING	16.7 / 22.5	20.6 / 25.9
INPUT	COOLIING	4.30 / 5.15	5.36 / 5.90
rated / max	(kW) HEATING	3.80 / 5.15	4.70 / 5.90
EER	COOLIING	2.91 kW/kW	2.61 kW/kW
rated	HEATING	3.68 kW/kW	3.40 kW/kW
MOISTURE REMOVAL		3.0 L/hr	4.0 L/hr
AIR CIRCULATION HIGH	3,500 m ³ /hr		

COMPRESSOR

TYPE	Hermetic type, 6 poles, 3-phase, Induction motor, DC Scroll		
DISCRIMINATION	ANB33FCMMT		
REFRIGERANT	R410A	3,400 g	

FAN MOTOR

INDOOR UNIT	DISCRIMINATION	MFA-60NTFS
	HIGH-SPEED	1,300 r.p.m.
	MED-SPEED	1,150 r.p.m.
	LOW-SPEED	990 r.p.m.
OUTDOOR UNIT	DISCRIMINATION	MFE-60PO
	HIGH-SPEED	850 r.p.m. (up fan) / 750 r.p.m. (down fan)

DIMENSIONS

INDOOR UNIT	H x W x D	400 x 1,050 x 500 mm
OUTDOOR UNIT	H x W x D	1,290 x 900 x 330 mm

WEIGHT

INDOOR UNIT	NET / GROSS	50 kg / 55 kg
OUTDOOR UNIT	NET / GROSS	105 kg / 112 kg

REFRIGERANT CHARGE (R410A)

FULL CHARGE AMOUNT	PIPE LENGTH	20.0 m	3,400 g
		30.0 m	3,800 g
		40.0 m	4,200 g
		50.0 m	4,600 g
		60.0 m	5,000 g
		70.0 m	5,400 g
ADDITIONAL CHARGE			40 g / m
CHARGELESS			20 m
MAX PIPE LENGTH			70 m
MAX ELEVATION			30 m

OUTLINE AND DIMENSIONS

INDOOR UNIT

(Unit : mm)

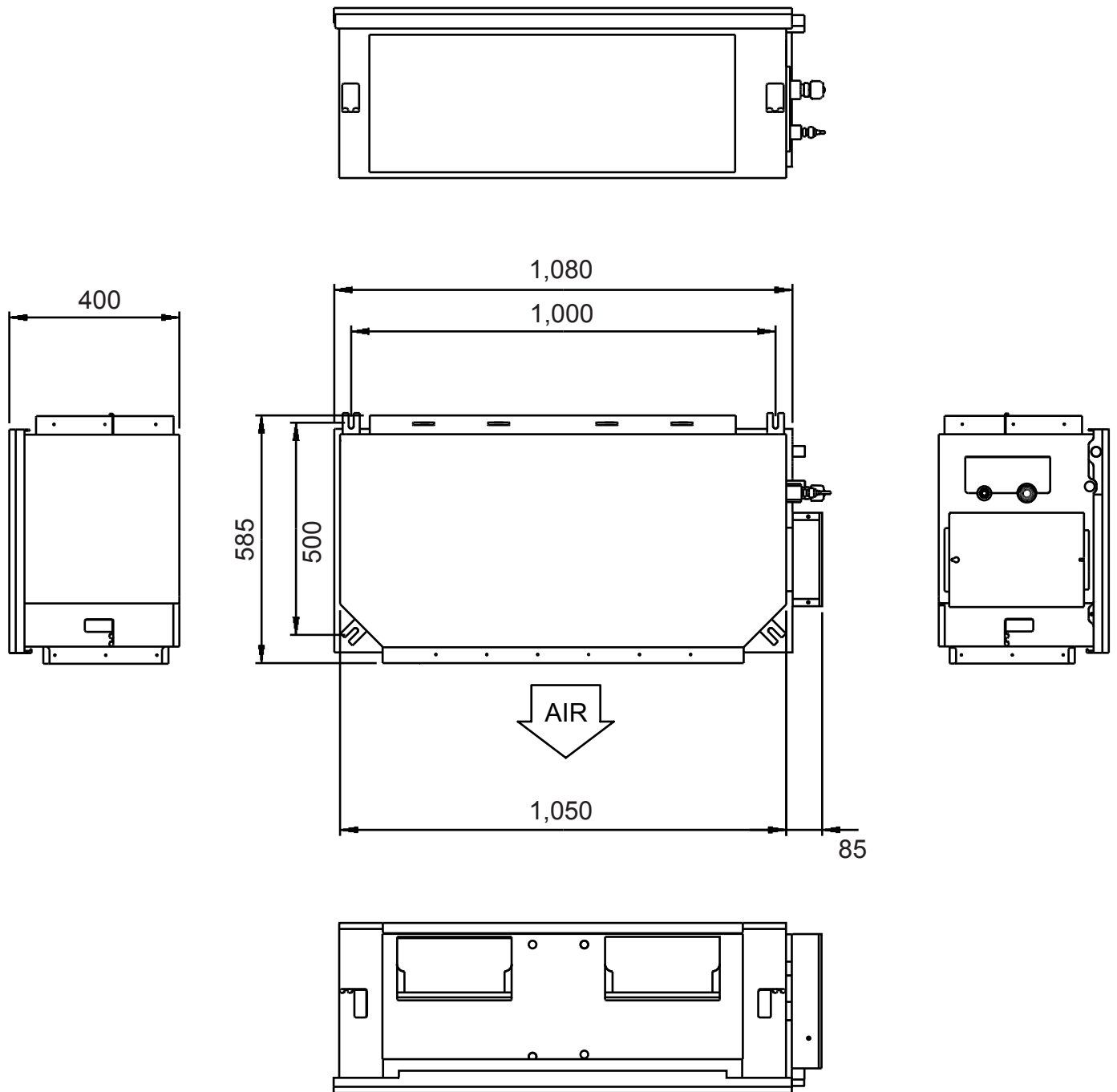

OUTDOOR UNIT

(Unit : mm)

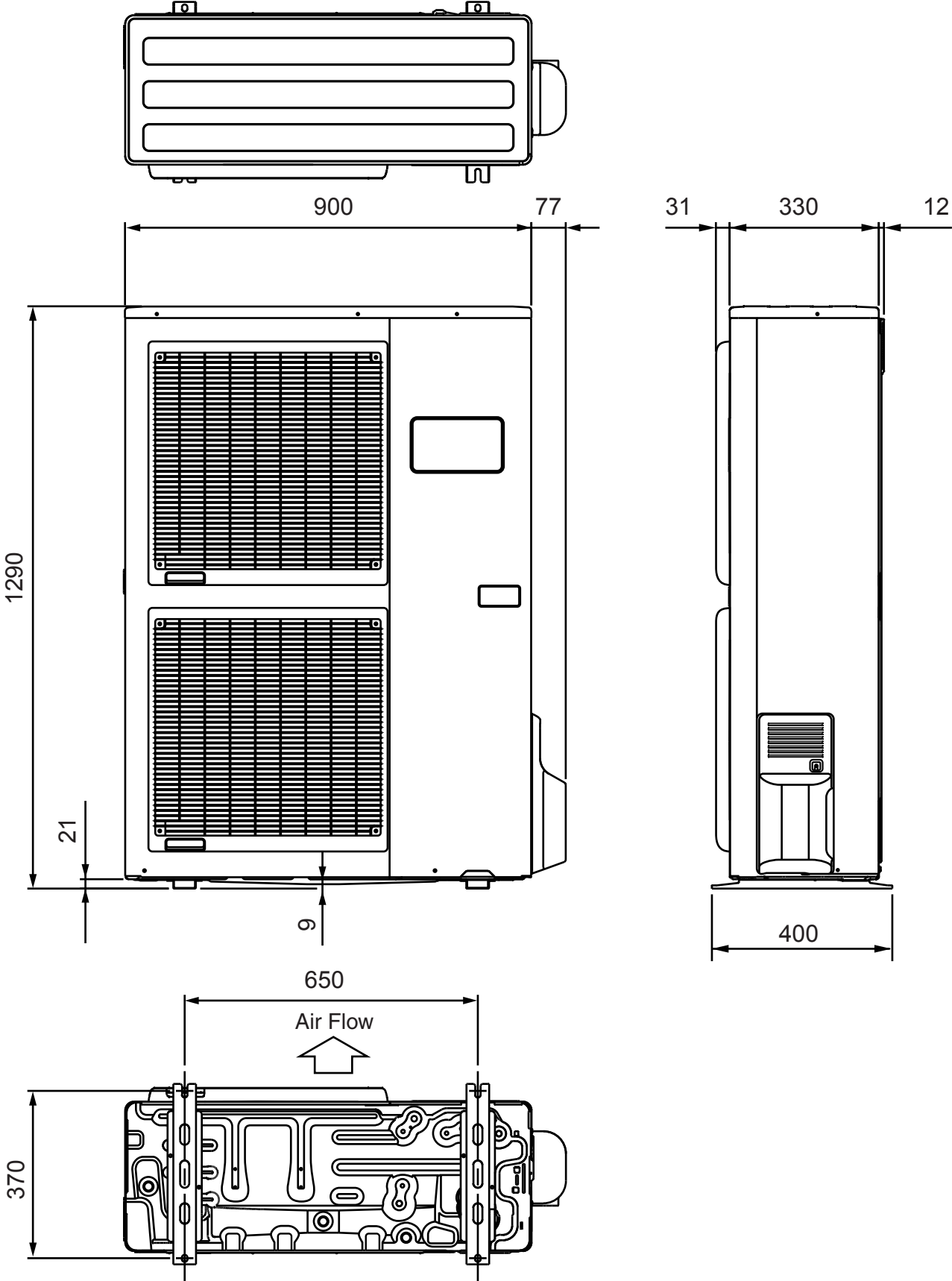

REFRIGERANT SYSTEM DIAGRAM

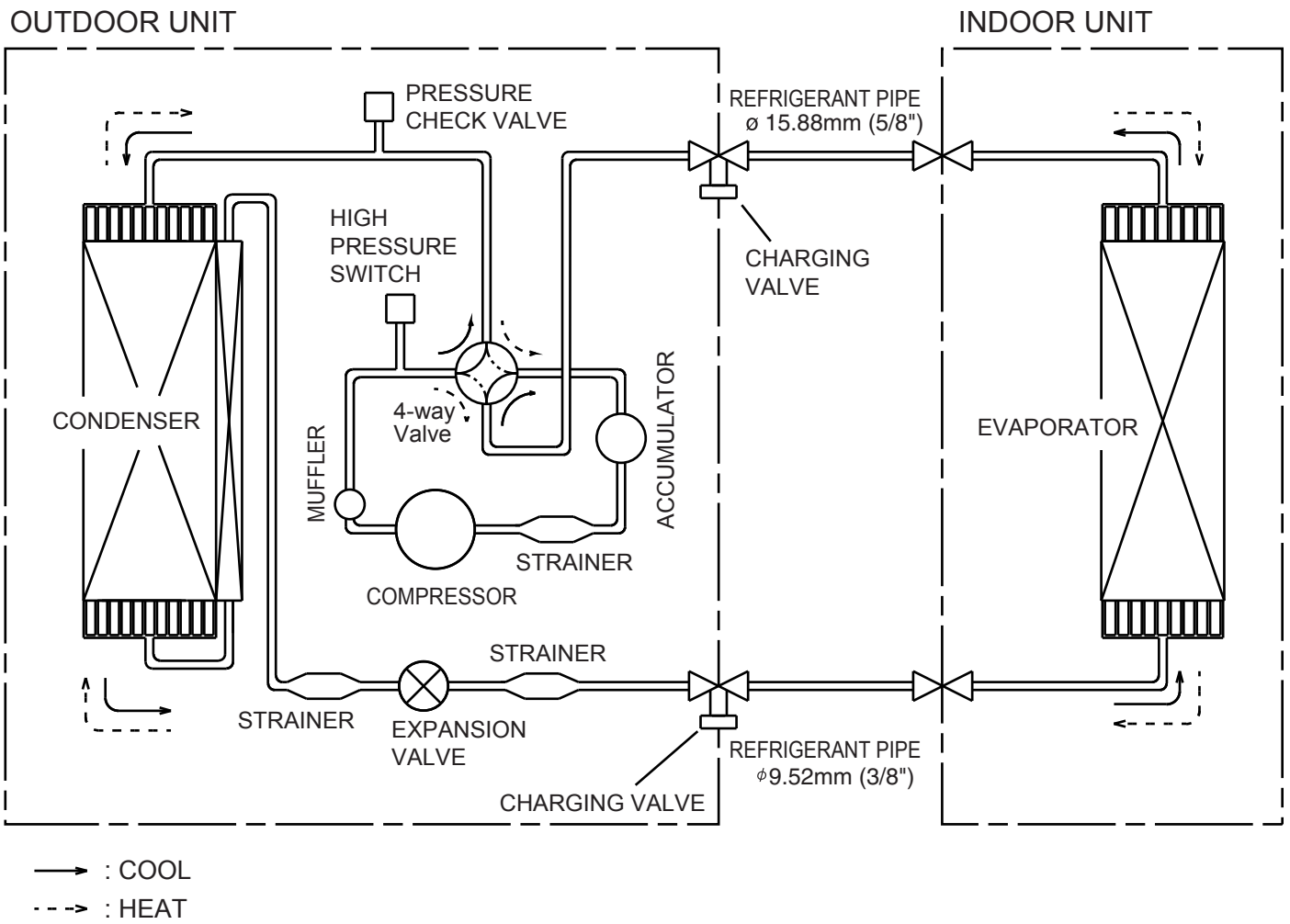

CIRCUIT DIAGRAM

INDOOR UNIT

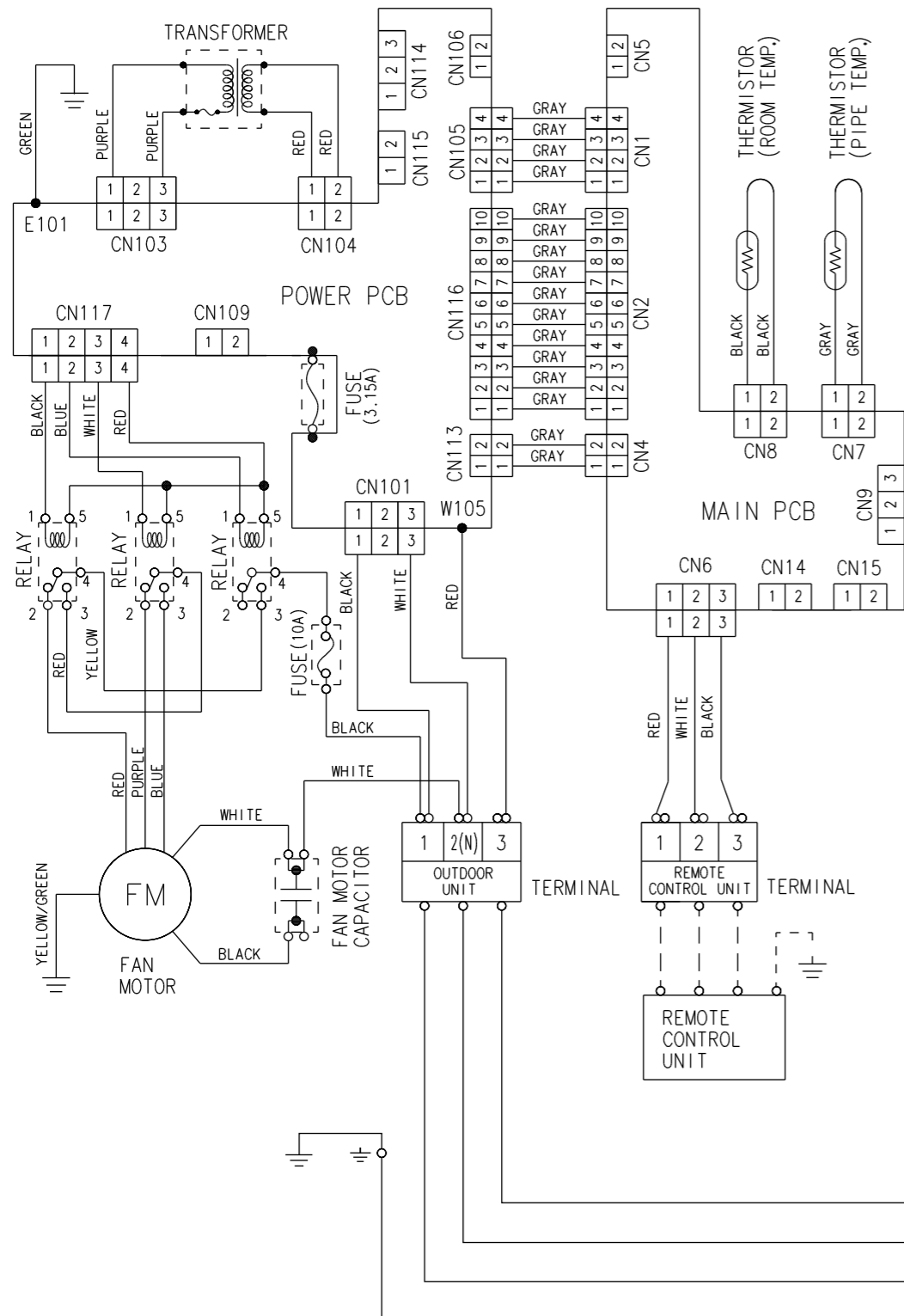

OUTDOOR UNIT

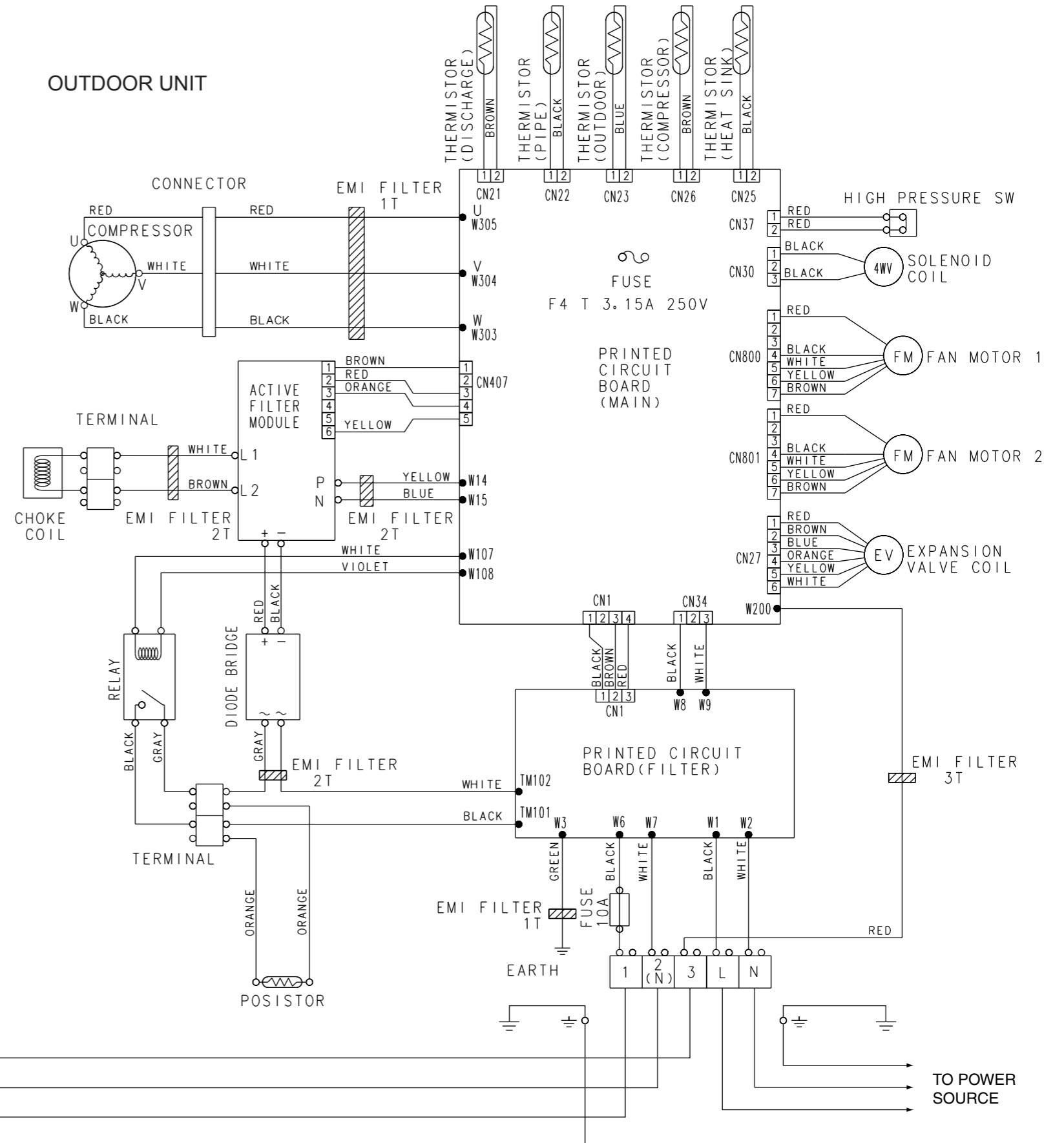

INDOOR PCB CIRCUIT DIAGRAM

Controller PCB Assy

ARH45LUAK : K03BZ-040BHSE-C1

ARH54LUAK : K03BZ-040AHSE-C1 Power Supply PCB
K04CW-0404HSE-P0

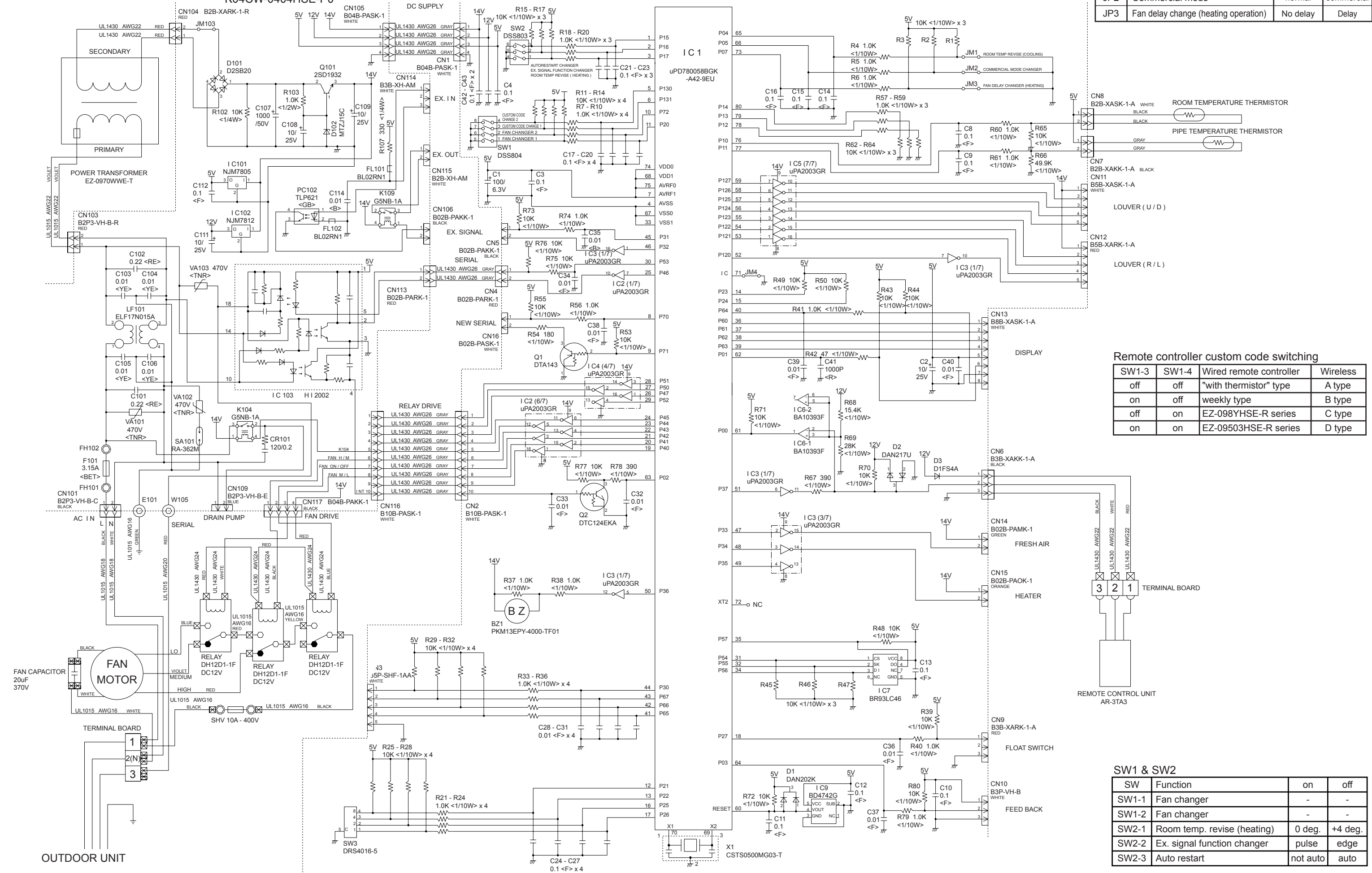

JP

JP	Function	on	off
JP1	Room temp. revise (cooling)	0 deg.	+2 deg.
JP2	Commercial mode	normal	commercial
JP3	Fan delay change (heating operation)	No delay	Delay

Remote controller custom code switching

SW1-3	SW1-4	Wired remote controller	Wireless
off	off	"with thermistor" type	A type
on	off	weekly type	B type
off	on	EZ-098YHSE-R series	C type
on	on	EZ-09503HSE-R series	D type

SW1 & SW2

SW	Function	on	off
SW1-1	Fan changer	-	-
SW1-2	Fan changer	-	-
SW2-1	Room temp. revise (heating)	0 deg.	+4 deg.
SW2-2	Ex. signal function changer	pulse	edge
SW2-3	Auto restart	not auto	auto

OUTDOOR PCB CIRCUIT DIAGRAM

Inverter Assy
 AOH45LJAYL : EZ-0045HUE
 AOH45LJBYL : EZ-0052HUE
 AOH54LJAYL : EZ-0046HUE
 AOH54LJBYL : EZ-0057HUE

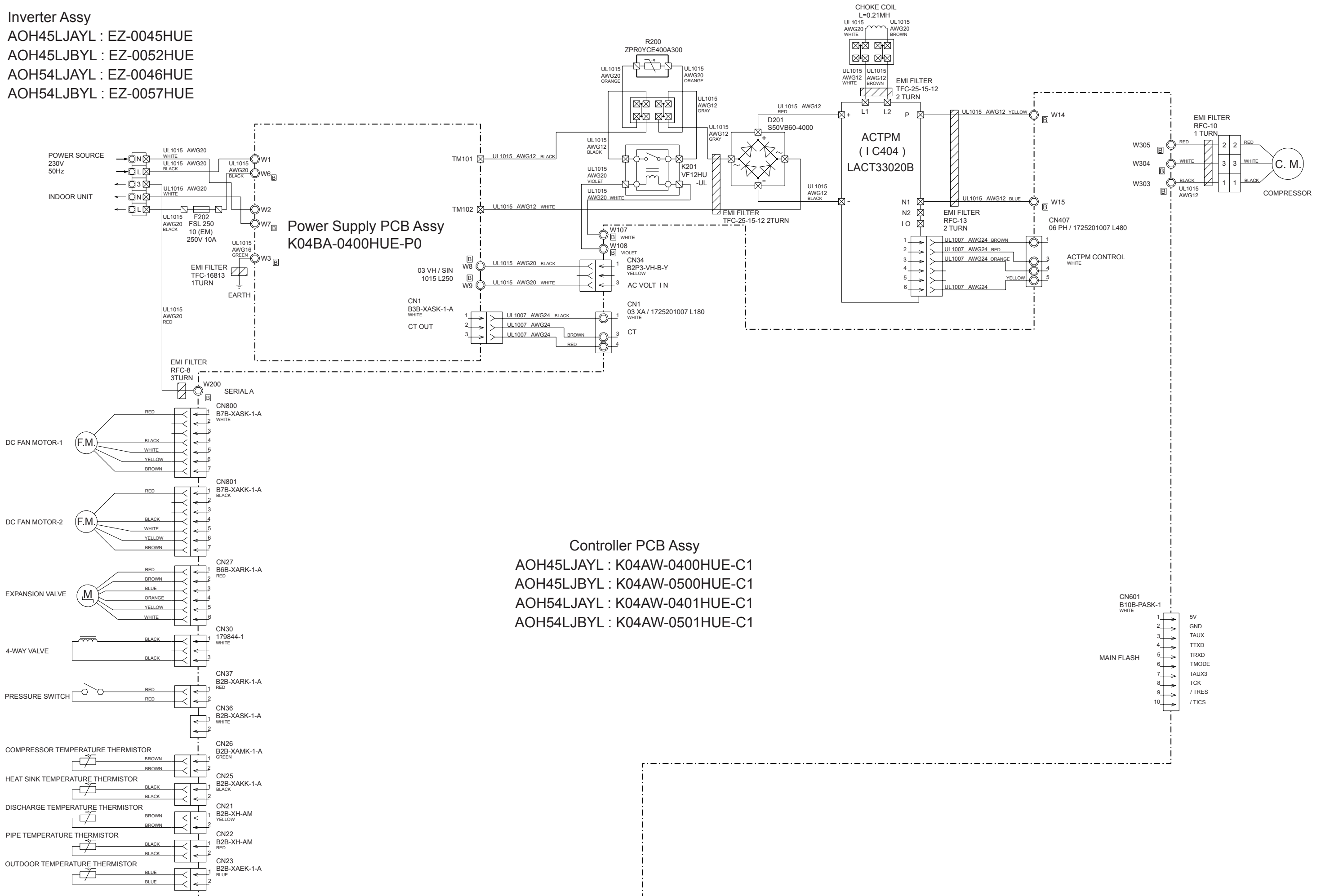

Controller PCB Assy

AOH45LJAYL : K04AW-0400HUE-C1

AOH45LJBYL : K04AW-0500HUE-C1

AOH54LJAYL : K04AW-0401HUE-C1

AOH54LJBYL : K04AW-0501HUE-C1

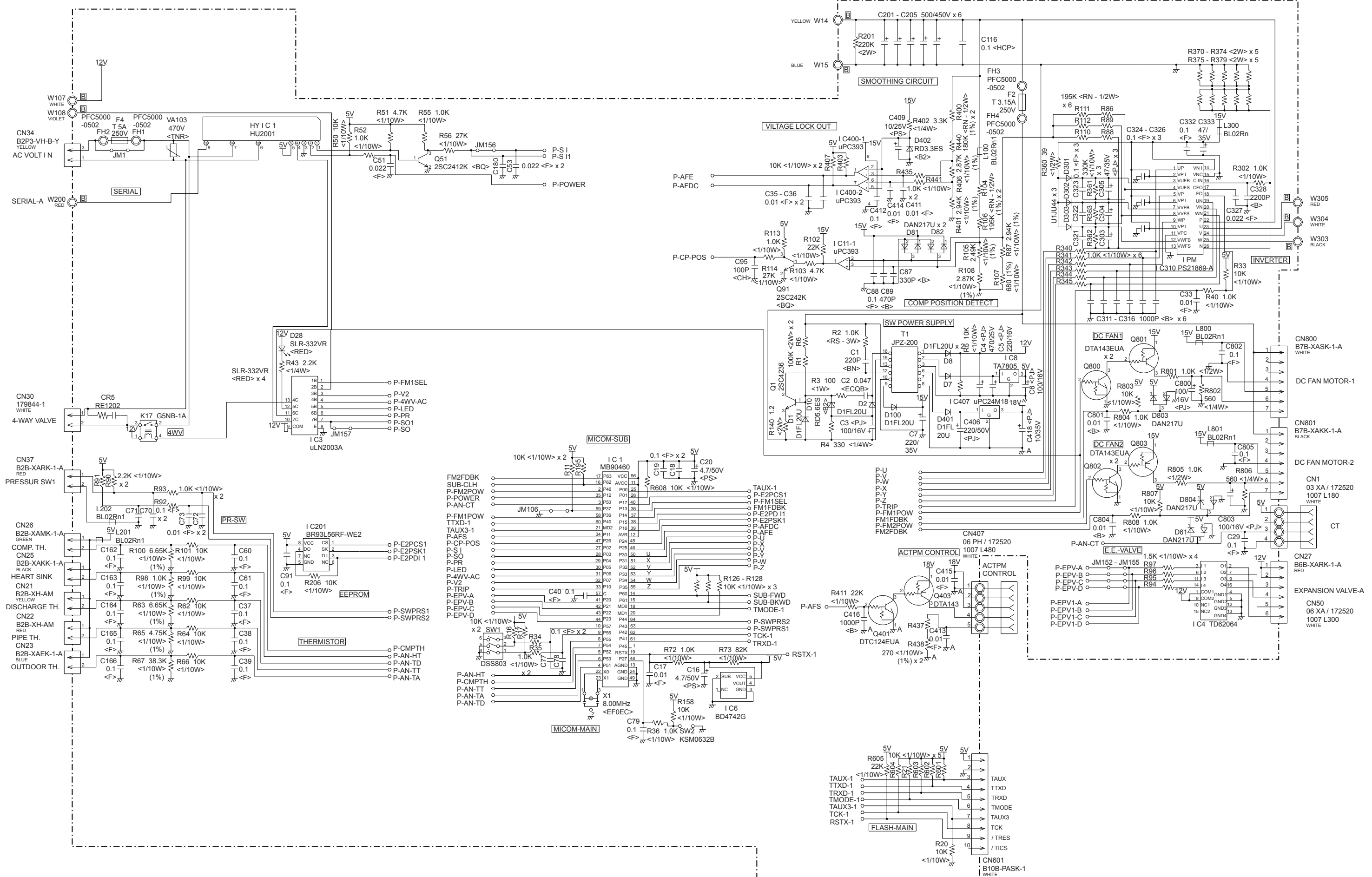

OUTDOOR UNIT
POWER SUPPLY PCB ASSEMBLY
K04BA-0400HUE-P0

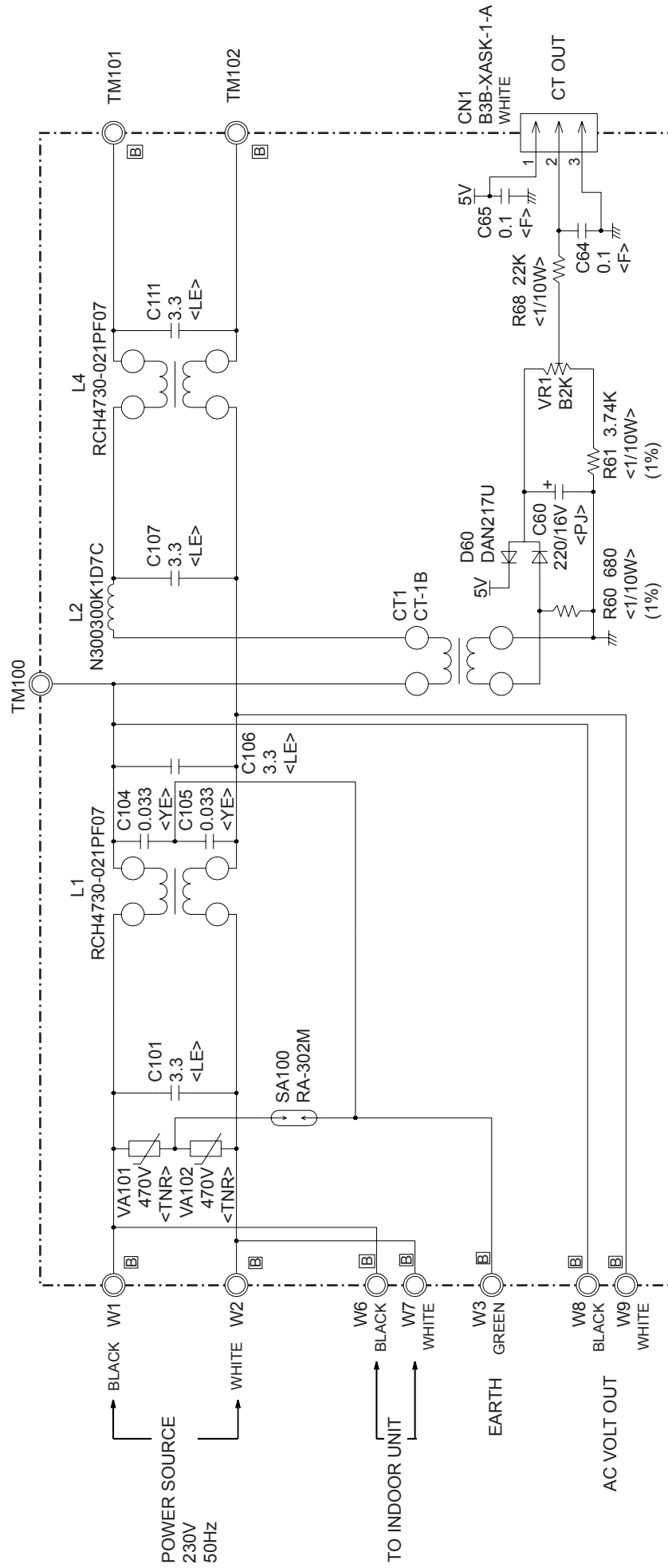

ERROR CONTENTS

CAUTION

Supply power to the crankcase heater for at least 12 hours before the start of operation in winter.

- Stop the air conditioner operation.
- Press the master control button and the fan control button simultaneously for 2 seconds or more to start the test run.

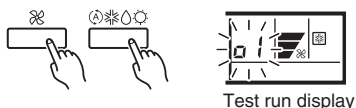

- Press the start/stop button to stop the test run.

[SELF-DIAGNOSIS]

When the error indication "E:EE" is displayed, follow the following items to perform the self-diagnosis. "E:EE" indicates an error has occurred.

1. REMOTE CONTROLLER DISPLAY

- Stop the air conditioner operation.
- Press the set temperature buttons \wedge / \vee simultaneously for 5 seconds or more to start the self-diagnosis.
Refer to the following tables for the description of each error code.

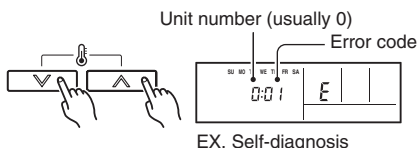

- Press the set temperature buttons \wedge / \vee simultaneously for 5 seconds or more to stop the self-diagnosis.

Error code	Error contents
00	Communication error (indoor unit ↔ remote controller)
01	Communication error (indoor unit ↔ outdoor unit)
02	Room temperature sensor open
03	Room temperature sensor short-circuited
04	Indoor heat exchanger temperature sensor open
05	Indoor heat exchanger temperature sensor short-circuited
06	Outdoor heat exchanger temperature sensor
08	Power source connection error
09	Float switch operated
0A	Outdoor temperature sensor
0c	Discharge pipe temperature sensor

Error code	Error contents
11	Model abnormal
12	Indoor fan abnormal
13	Outdoor signal abnormal
14	Outdoor EEPROM abnormal
15	Compressor temperature sensor
16	Pressure switch abnormal
17	IPM error
1A	Compressor cannot operate
1b	Outdoor fan abnormal

2. OUTDOOR UNIT LEDS

Heat & Cool model (reverse cycle) only

When a malfunction occurs in the outdoor unit, the LED on the circuit board door unit, the LED on the circuit board light to indicate the error. Refer to the following table for the description of each error according to the LED.

LED1	Error contents
1 flash	Communication error (Indoor unit → Outdoor unit)
2 flash	Discharge pipe temperature sensor
3 flash	Outdoor heat exchanger temperature sensor
4 flash	Outdoor temperature sensor
7 flash	Compressor temperature sensor
8 flash	Heatsink temperature sensor
9 flash	Pressure switch abnormal
12 flash	IPM error
13 flash	Compressor rotor position cannot detect
14 flash	Compressor cannot operate
15 flash	Outdoor fan abnormal (upper fan)
16 flash	Outdoor fan abnormal (lower fan)
5 sec. ON/ 1 sec. OFF repeated	Protect operation
lighting	No error

PUMP DOWN (Refrigerant collecting operation)

Perform the following procedures to collect the refrigerant when moving the indoor unit or the outdoor unit.

(1) Press the push-button switch (SW2) on the circuit board once. The LED on the circuit board starts flashing (one second ON/ one second OFF). This indicates the start of PUMP DOWN operation.

When the switch is pressed while the compressor is in operation, PUMP DOWN operation starts automatically.

When the switch is pressed while the compressor is in stop, the compressor starts to operate automatically, and then move on to PUMP DOWN operation.

(2) PUMP DOWN operation continues for about 1 minute. When PUMP DOWN operation is completed, the compressor stops automatically. Then close the 2-way valve and 3-way valve within 1 minute.

(3) Turn the power off.

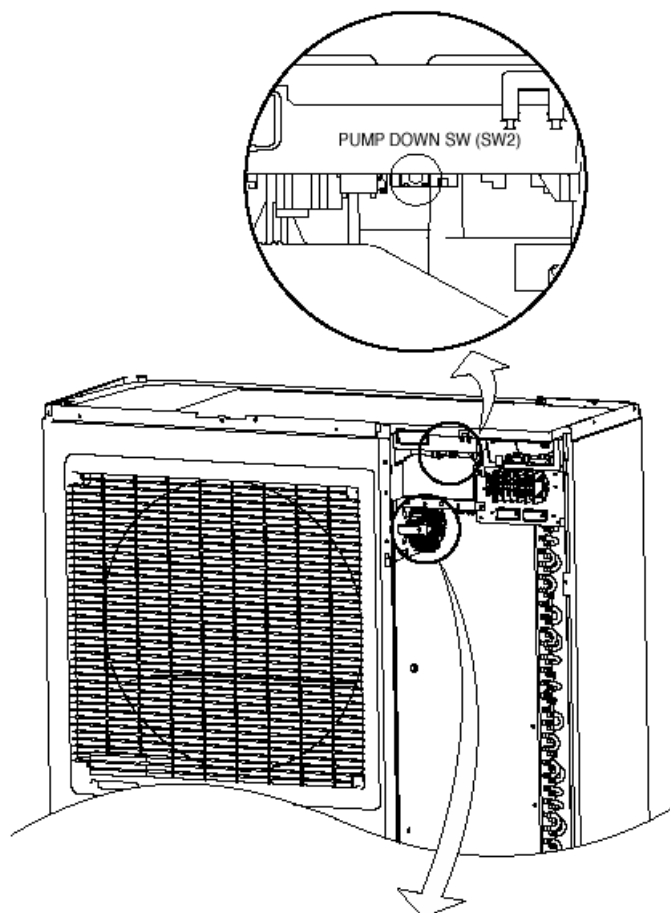

 **DANGER**

**This part (Choke coil) generates high voltages.
Never touch this part.**

DISASSEMBLY ILLUSTRATION

INDOOR UNIT

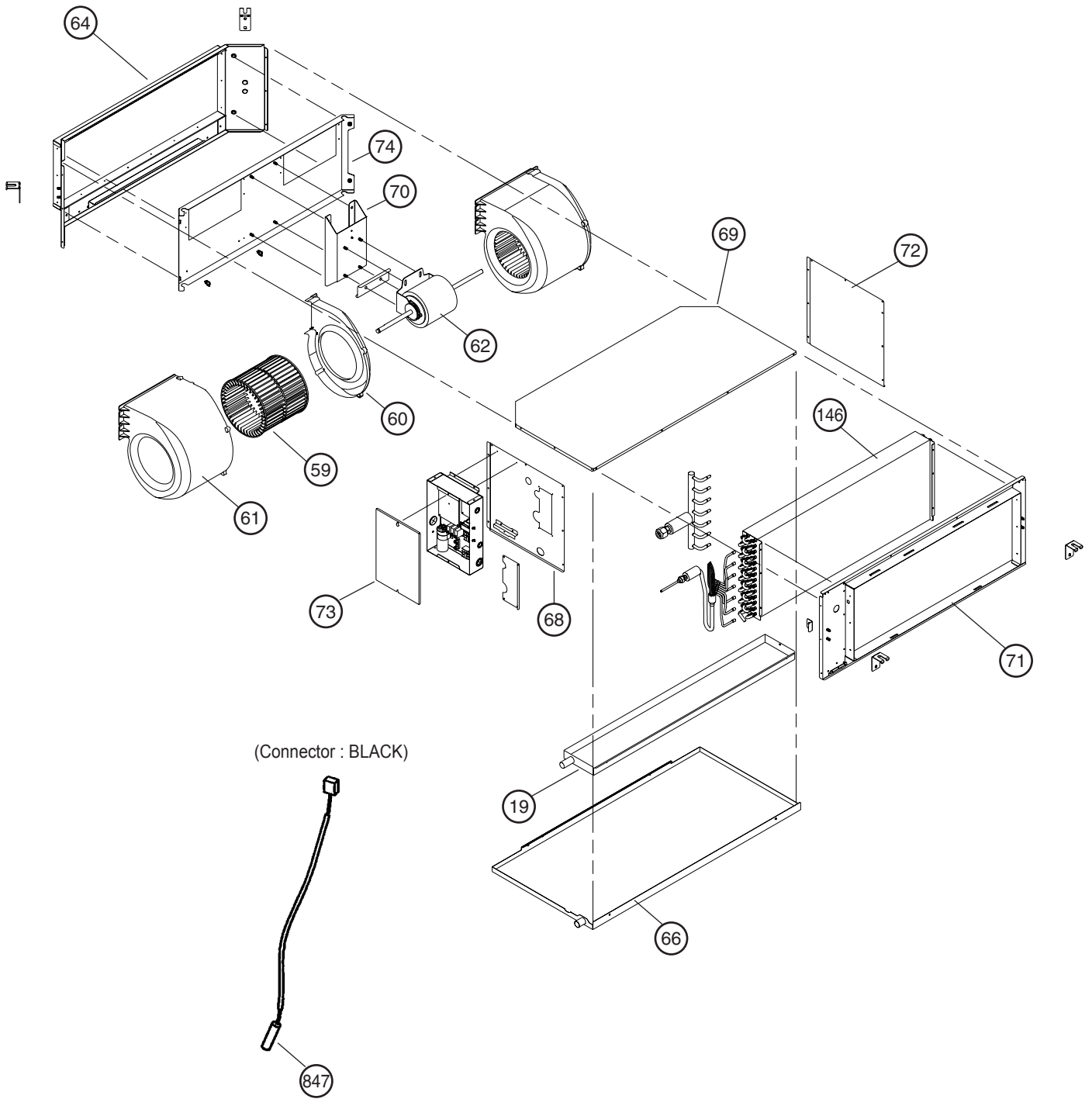

INDOOR UNIT

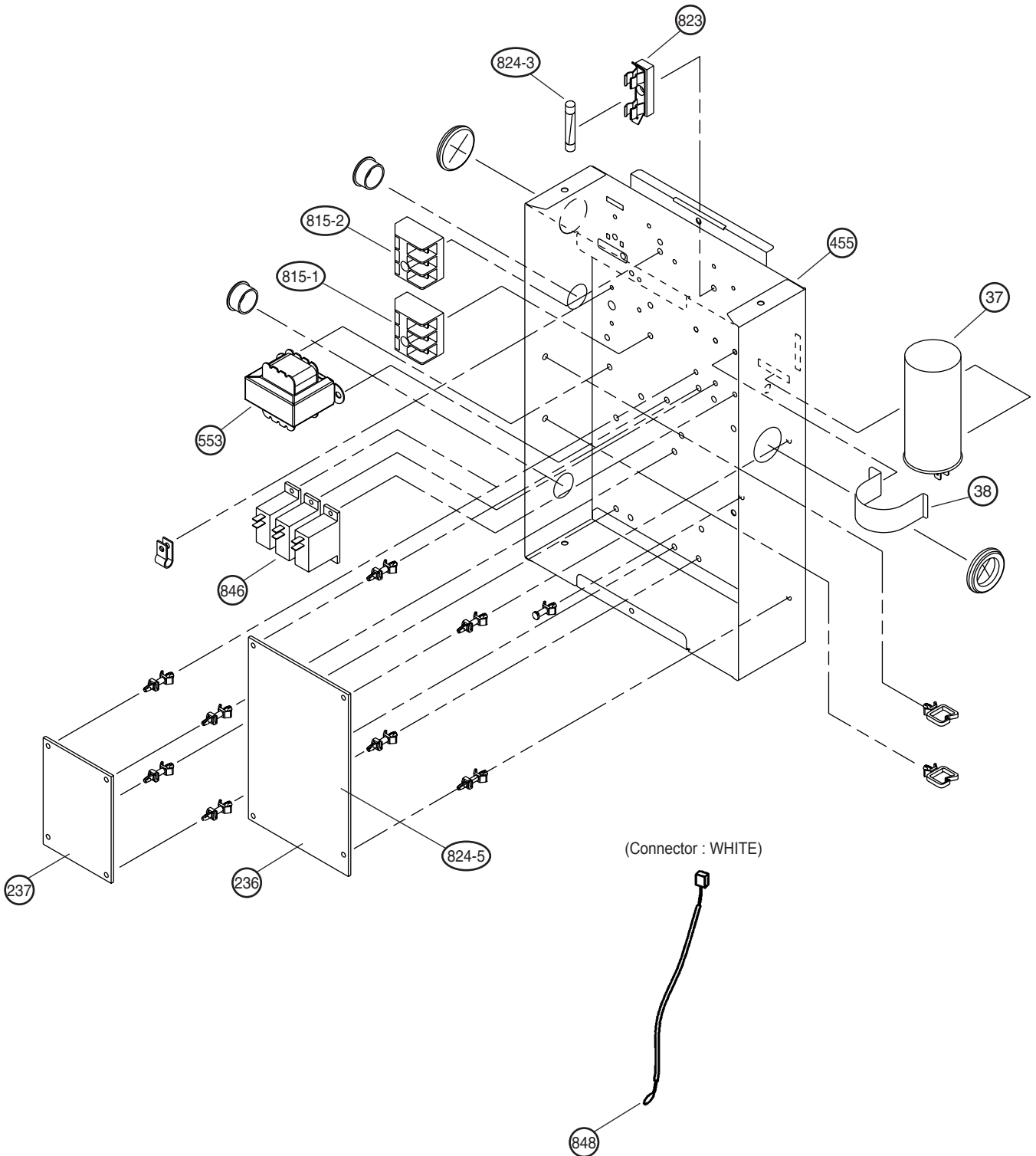

OUTDOOR UNIT

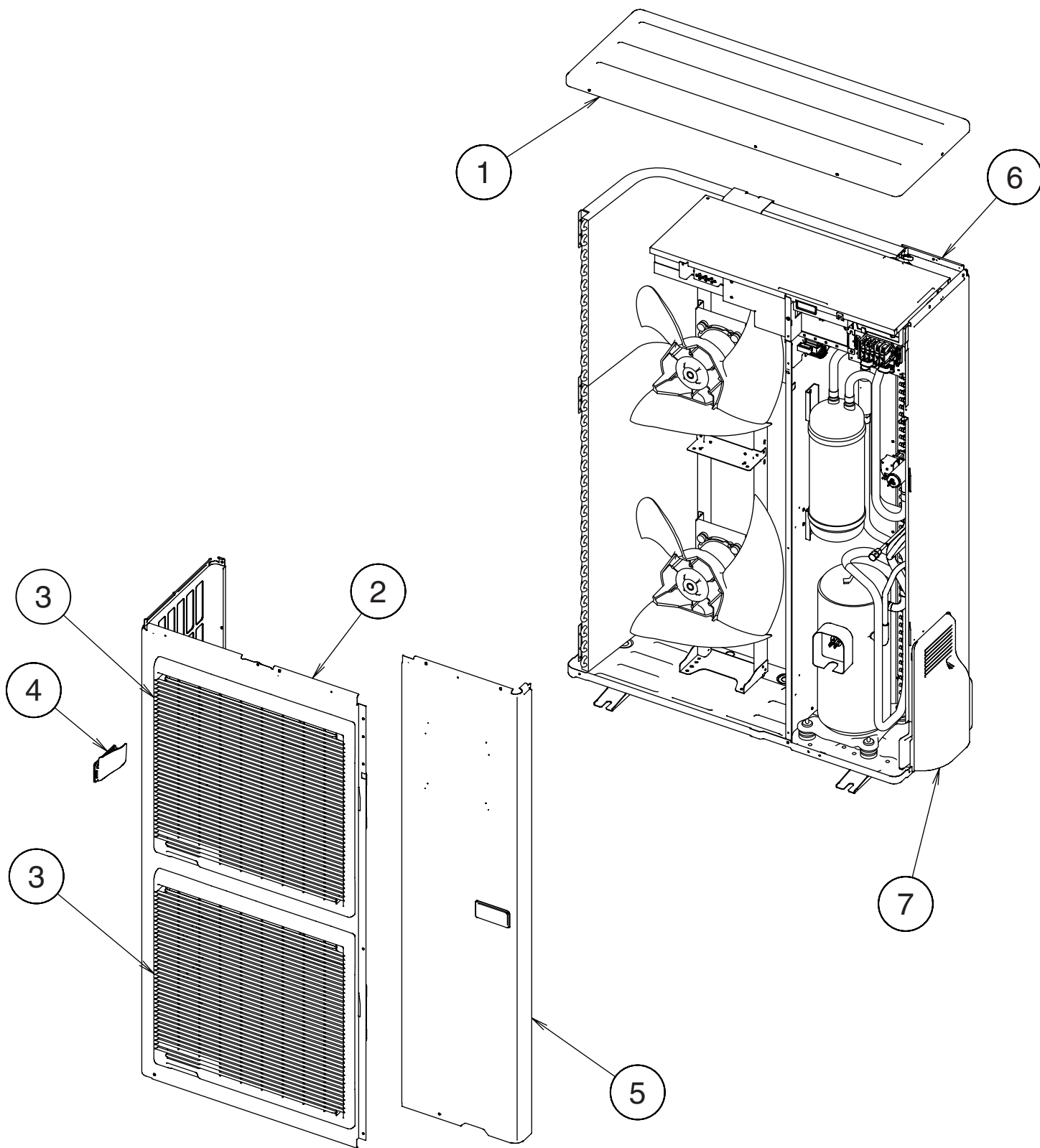

OUTDOOR UNIT

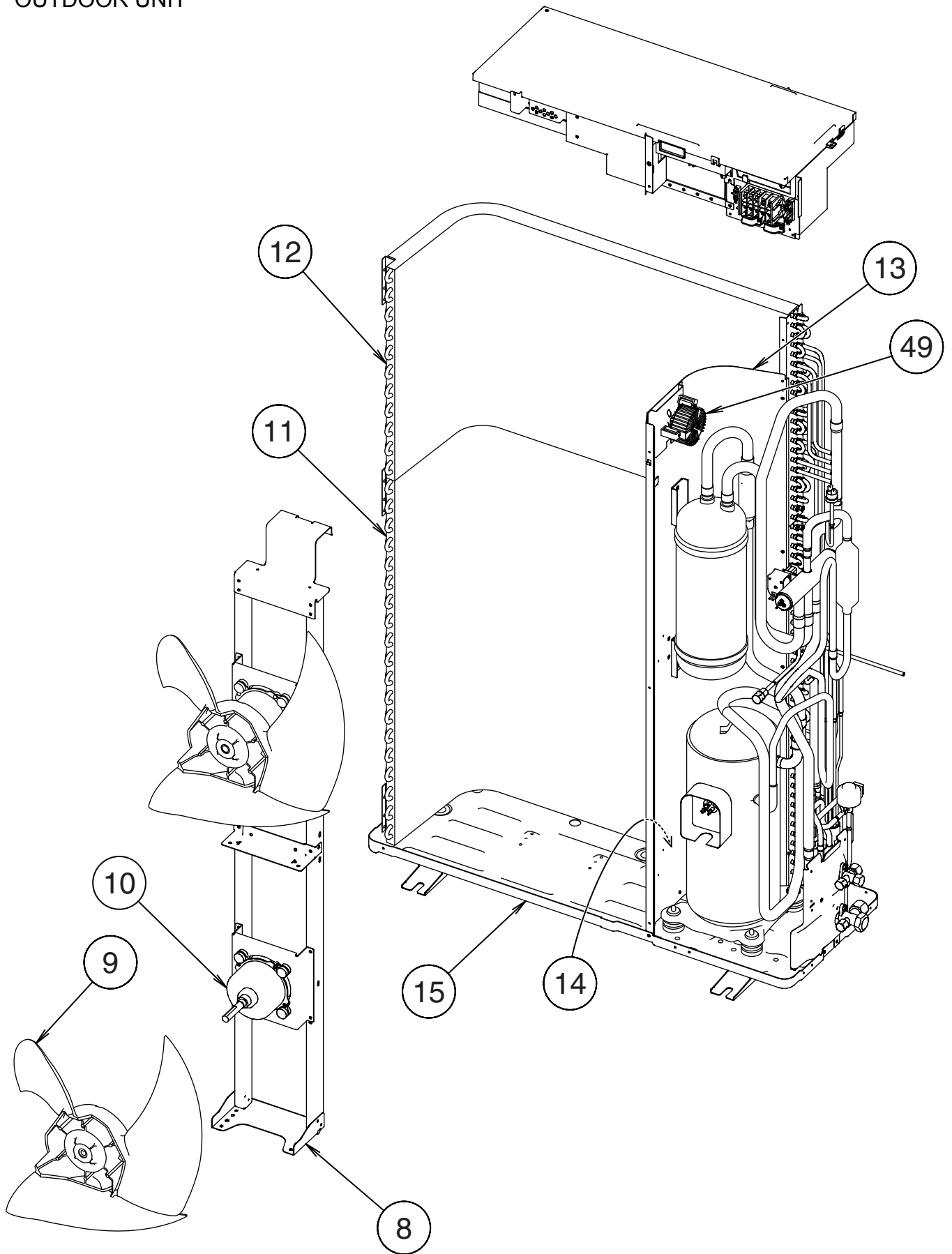

OUTDOOR UNIT

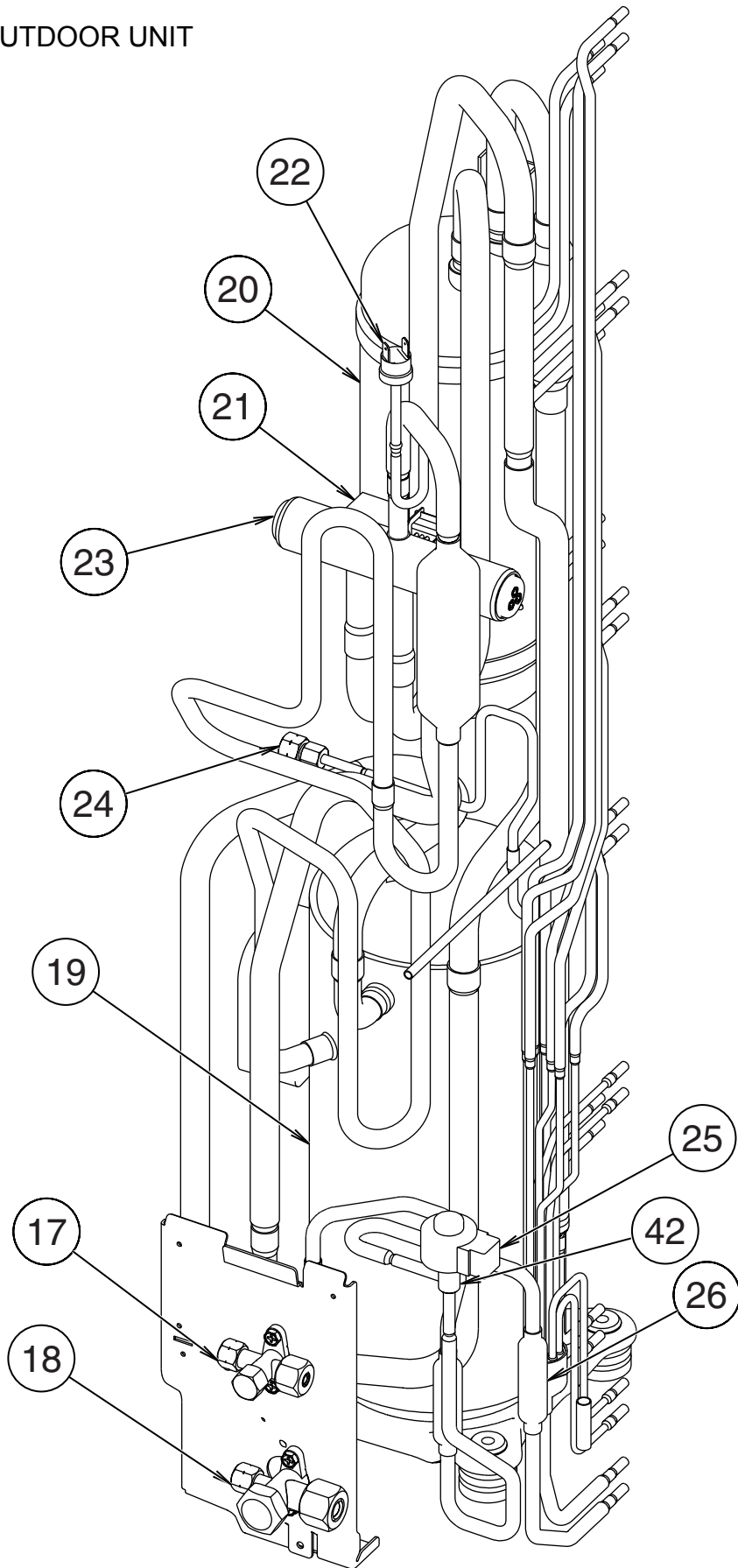

OUTDOOR UNIT

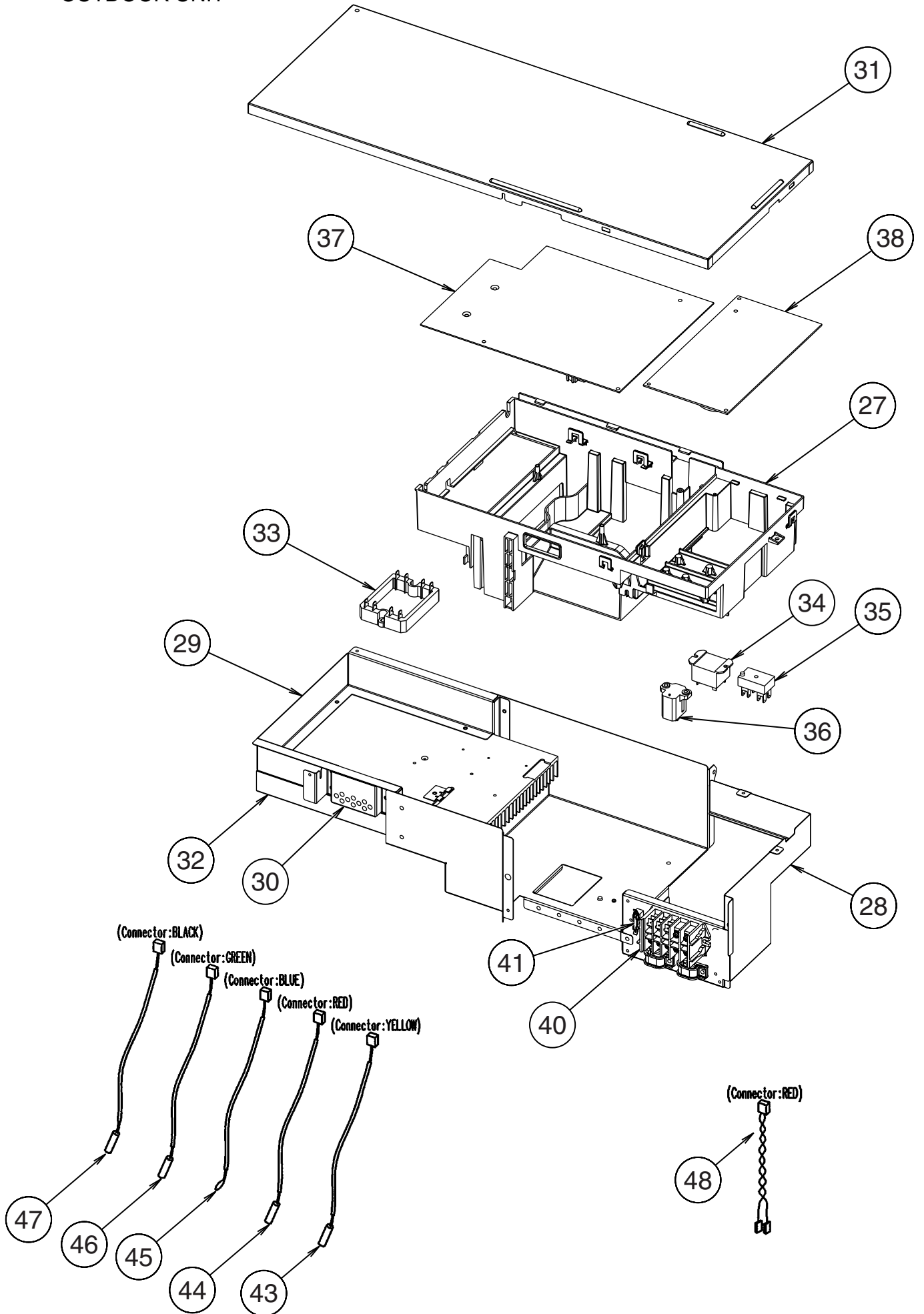

PARTS LIST

Indoor unit

Ref. No.	Description	Parts No.		Ord. Q'ty
		ARH45LUAK	ARH54LUAK	
19	Drain Pan Assy	9372579015	9372579015	
37	Capacitor, Plastic	9900269111	9900269111	
38	Capacitor Clamp	9308114006	9308114006	
59	Sirocco Fan	9372059012	9372059012	
60	Casing B	9372058015	9372058015	
61	Casing A	9372057018	9372057018	
62	Motor, Induct	9601688013	9601688013	
64	Kit (Panel Front Sub Assy)	9372637012	9372637012	
66	Drain Pan Sub Assy	9372582015	9372582015	
68	Kit (Panel Right Sub Assy)	9372916018	9372916018	
69	Plate Top Sub Assy	9372576014	9372576014	
71	Kit (Panel Rear Sub Assy)	9372636015	9372636015	
70	Bracket Motor Assy	9372037003	9372037003	
72	Kit (Panel Left Sub Assy)	9372581018	9372581018	
73	Cover Box	9372061008	9372061008	
74	Panel Fan Assy	9372035009	9372035009	
146	Evaporator Assy	9372584057	9372584057	
236	Power Supply PCB Assy	9705668058	9705668058	
237	Controller PCB Assy	9705246119 (K03BZ-040BHSE-C1)	9705246102 (K03BZ-040AHSE-C1)	
455	Control Box Assy	9372536001	9372536001	
553	Transformer (Power)	9704129017	9704129017	
815-1	Terminal 3P	9306489045	9306489045	
815-2	Terminal 3P	9703345012	9703345012	
823	Fuse Holder	0501454012	0501454012	
824-3	Fuse	0600222512	0600222512	
824-5	Fuse	0600315023	0600315023	
846	Relay	9900294014	9900294014	
847	Pipe Thermistor	9703297113	9703297113	
848	Room Thermistor	9703299216	9703299216	
---	Thermo. Spring A	313728262708	313728262708	
---	Remote Controller Assy	9372266014	9372266014	







Outdoor unit

Ref. No.	Description	Parts No.				Ord. Q'ty
		AOH45LJAYL	AOH45LJBYL	AOH54LJAYL	AOH54LJBYL	
1	Top Panel Sub Assy	9374417018	9374417025	9374417018	9374417018	
2	Front Panel X	9374094028	9374094028	9374094028	9374094028	
3	Fan Guard	9374330010	9374330010	9374330010	9374330010	
4	Grip Side	9374173013	9374173013	9374173013	9374173013	
5	Service Panel Sub Assy	9374415014	9374415014	9374415014	9374415014	
6	Right Panel Sub Assy	9374416011	9374416042	9374416011	9374416011	
7	Valve Cover	9374174010	9374174010	9374174010	9374174010	
8	Motor Bracket Sub Assy	9374418015	9374418046	9374418015	9374418015	
9	Propeller Fan Assy	9366378013	9366378020	9366378013	9366378013	
10	Motor DC Brushless	9601882015	9601882015	9601882015	9601882015	
11	Condenser A Assy	9374433018	9374433018	9374433018	9374433018	
12	Condenser B Assy	9374434015	9374434015	9374434015	9374434015	
13	Separate Wall	9374135028	9374135028	9374135028	9374135028	
14	Cap Foot	9374345014	9374345014	9374345014	9374345014	
15	Base Assy	9374166022	9374166060	9374166022	9374166022	
17	3-Way Valve Assy	9372205044	9372205044	9372205044	9372205044	
18	3-Way Valve Assy	9372205075	9372205075	9372205075	9372205075	
19	Compressor Assy	9374653010	9374653010	9374653010	9374653010	
20	Accumulator Assy	9371615011	9371615011	9371615011	9371615011	
21	Solenoid	9900165055	9900165055	9900165055	9900165055	
22	Pressure Switch	9900186012	9900186012	9900186012	9900186012	
23	4-Way Valve	9970035029	9970035029	9970035029	9970035029	
24	Check Valve Assy	9374274017	9374274017	9374274017	9374274017	
25	Coil (Expansion Valve)	9900190033	9900190033	9900190033	9900190033	
26	Strainer Assy	9372524015	9372524015	9372524015	9372524015	
27	Inverter Box A	9374603015	9374603015	9374603015	9374603015	
28	Inverter Box B	9374625017	9374625017	9374625017	9374625017	
29	Inverter Box C	9374605019	9374605019	9374605019	9374605019	
30	Inverter Box Duct	9374609017	9374609017	9374609017	9374609017	
31	Inverter Box Cover	9374608010	9374608010	9374608010	9374608010	
32	Heat Sink A	9374607013	9374607013	9374607013	9374607013	
33	Act-Module	9707278019	9707278019	9707278019	9707278019	
34	Relay	9900262013	9900262013	9900262013	9900262013	
35	Terminal	9701971015	9701971015	9701971015	9701971015	
36	Posistor	9704265012	9704265012	9704265012	9704265012	
37	Inverter PCB Assy	9705642010	9705642065	9705642027	9705642072	
38	Power PCB Assy	9705647015	9705647015	9705647015	9705647015	
40	Terminal	9900184025	9900184025	9900184025	9900184025	
41	Fuse	0600376116	0600376116	0600376116	0600376116	
42	Expansion Valve	9900170028	9900170028	9900170028	9900170028	
43	Thermistor (Discharge)	9704219084	9704219084	9704219084	9704219084	
44	Thermistor (Heat Exchange)	9704220066	9704220066	9704220066	9704220066	
45	Thermistor (Out Temp)	9703516078	9703516078	9703516078	9703516078	
46	Compressor Temp Thermistor	9900156039	9900156039	9900156039	9900156039	
47	Heat Sink Thermistor	9900311018	9900311018	9900311018	9900311018	
48	Wire (Pressure SW)	9367595051	9367595051	9367595051	9367595051	
49	Coil, Choke	9705877016	9705877016	9705877016	9705877016	
---	Emblem-Rear	9372171011	9372171011	9372171011	9372171011	

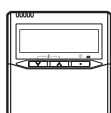

STANDARD ACCESSORIES

The following installation parts are furnished. Use them as required.

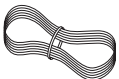
INDOOR UNIT ACCESSORIES

Name and Shape	Q'ty	Application
Special nut A (large flange) 	4	For suspending the indoor unit from ceiling
Special nut B (small flange) 	4	
Coupler heat insulation (large) 	1	For indoor side pipe joint (gas pipe)
Coupler heat insulation (small) 	1	For indoor side pipe joint (liquid pipe)
Binder 	1	For fixing the remote controller cord
Remote controller 	1	
Tapping screw (flush heads) 	2	For installing the remote controller
Remote controller cord 	1	For connecting the remote controller

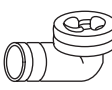
OUTDOOR UNIT ACCESSORIES

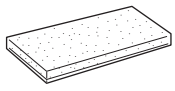
Name and Shape	Q'ty	Application
Drain pipe 	1	For outdoor unit drain piping work (May not be supplied, depending on the model.)
Drain cap 	2	
Insulation (seal) 	1	For filling in a gap at the entrance of connection cords.

OPTIONAL PARTS

The following options are available.

- Long-life filter : UTD-LF60KA (P/N 9017230004).
- Simple remote controller : UTB-YPB (P/N 9077582006)
- Remote sensor : UTD-RS100 (P/N 9072619004)
- External control set : UTD-ECS5A (P/N 9077359004)

0502G2761