



**INVERTER MULTI
AIR CONDITIONER
WALL MOUNTED type**

**SERVICE
MANUAL**

Models

Indoor unit

Outdoor unit

ASH18LBAJ }
ASH24LBAJ } AOH30LMAW4



CONTENTS

SPECIFICATIONS 1
OUTLINE AND DIMENSIONS 3
REFRIGERANT SYSTEM DIAGRAM 5
CIRCUIT DIAGRAM 6
INDOOR PCB CIRCUIT DIAGRAM 8
OUTDOOR PCB CIRCUIT DIAGRAM 9
ERROR CONTENTS 12
DISASSEMBLY ILLUSTRATION 13
PARTS LIST 21

SPECIFICATIONS

TYPE	COOL & HEAT	COOL & HEAT
INDOOR UNIT	ASH18LBAJ	ASH24LBAJ

ELECTRICAL DATA

POWER SOURCE	(V)	230	
FREQUENCY	(Hz)	50	
MOISTURE REMOVAL	(ℓ /hr)	3.0	3.0
AIR CIRCULATION-Hi	(m^3 /hr)	1,020	1,020

FAN MOTOR

POWER SOURCE	(V)	230	230
INDOOR UNIT	DISCRIMINATION	MFA-30HTT	MFA-30HTT
	HI-SPEED (r.p.m.)	1,160	1,290
	MED-SPEED (r.p.m.)	1,000	1,100
	LO-SPEED (r.p.m.)	830	870
	QUIET (r.p.m.)	780	730

DIMENSIONS	H x W x D (mm)	320 x 1,120 x 220
WEIGHT	GROSS / NET (kg)	22 / 16

NOISE LEVEL

INDOOR UNIT	HI-SPEED (dB)	COOL 43 / HEAT 43	COOL 47 / HEAT 47
	MED-SPEED (dB)	COOL 39 / HEAT 39	COOL 41 / HEAT 41
	LO-SPEED (dB)	COOL 35 / HEAT 35	COOL 36 / HEAT 36
	QUIET-SPEED (dB)	COOL 32 / HEAT 32	COOL 32 / HEAT 32

OUTDOOR UNIT

TYPE	Cooling & Heating	
MODEL NAME	AOH30LMAW4	
COOLING CAPACITY	(kW)	8.0
HEATING CAPACITY	(kW)	9.6

ELECTRICAL SPECIFICATIONS

POWER SUPPLY	(V)	(220) - 230 - (240)	
FREQUENCY	(Hz)	50	
RUNNING CURRENT	(A)	COOLING	9.7
		HEATING	10.5
INPUT	(kW)	COOLING	2.22
		HEATING	2.40
EER	(kW/kW)	COOLING	3.60
		HEATING	4.00
AIR CIRCULATION - Hi	(m ³ /hr)	3,300	

COMPRESSOR

TYPE	Hermetic type, Inverter, 4 poles, 3-phase, DC motor, Twin Rotary		
DISCRIMINATION	TNB220FPBM9		
REFRIGERANT	R410	(g)	3,300

FAN MOTOR

DISCRIMINATION	MFE-60PO		
HI-SPEED (COOL / HEAT)	(r.p.m.)	820 / 780	

DIMENSIONS	H x W x D	(mm)	830 x 900 x 330
WEIGHT	NET / GROSS	(kg)	68 / 78

REFRIGERANT CHARGE (R410A)

FULL CHARGE AMOUNT	Total Pipe Length	50.0 m	3,300 g
		60.0 m	3,550 g
		70.0 m	3,800 g
ADDITIONAL CHARGE			25 g / m
CHARGELESS			50 m
MAX PIPE LENGTH (each unit)			25 m
MAX PIPE LENGTH (total)			70 m
MAX ELEVATION (between indoor units)			10 m
MAX ELEVATION (between indoor and outdoor units)			10 m
MIN. PIPE LENGTH (each unit)			5 m

OUTLINE AND DIMENSIONS

Unit : mm

**Models : ASH18LBAJ
ASH24LBAJ**

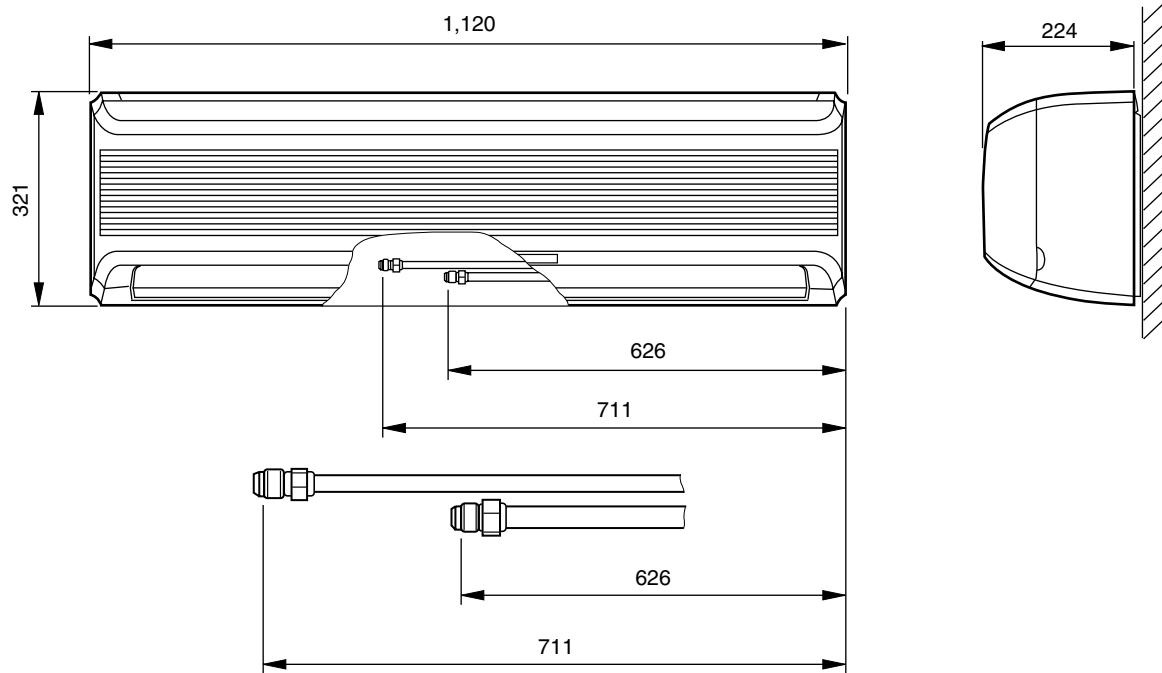

OUTDOOR UNIT (Unit : mm)

Model : AOH30LMAW4

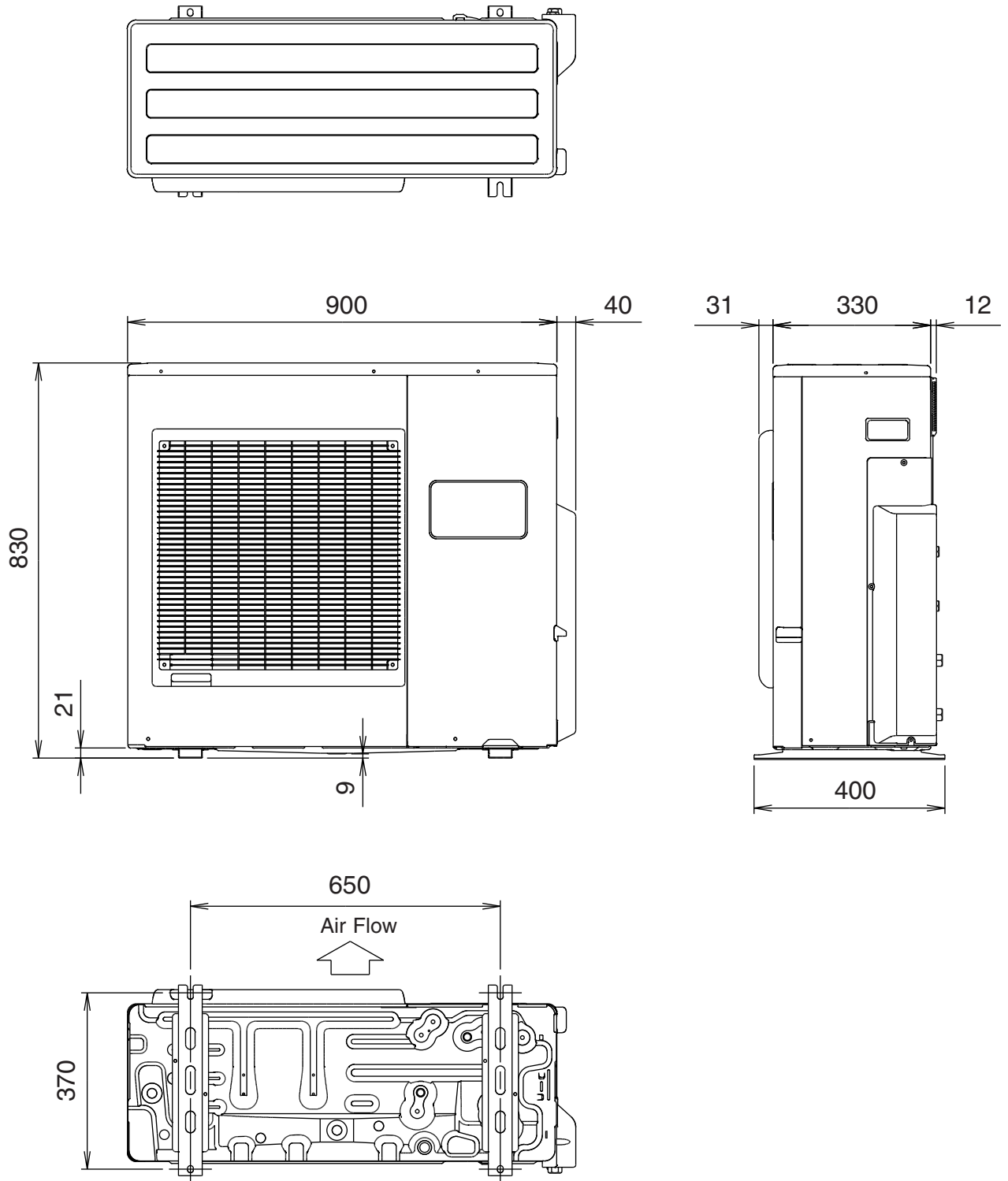

REFRIGERANT SYSTEM DIAGRAM

Outdoor unit

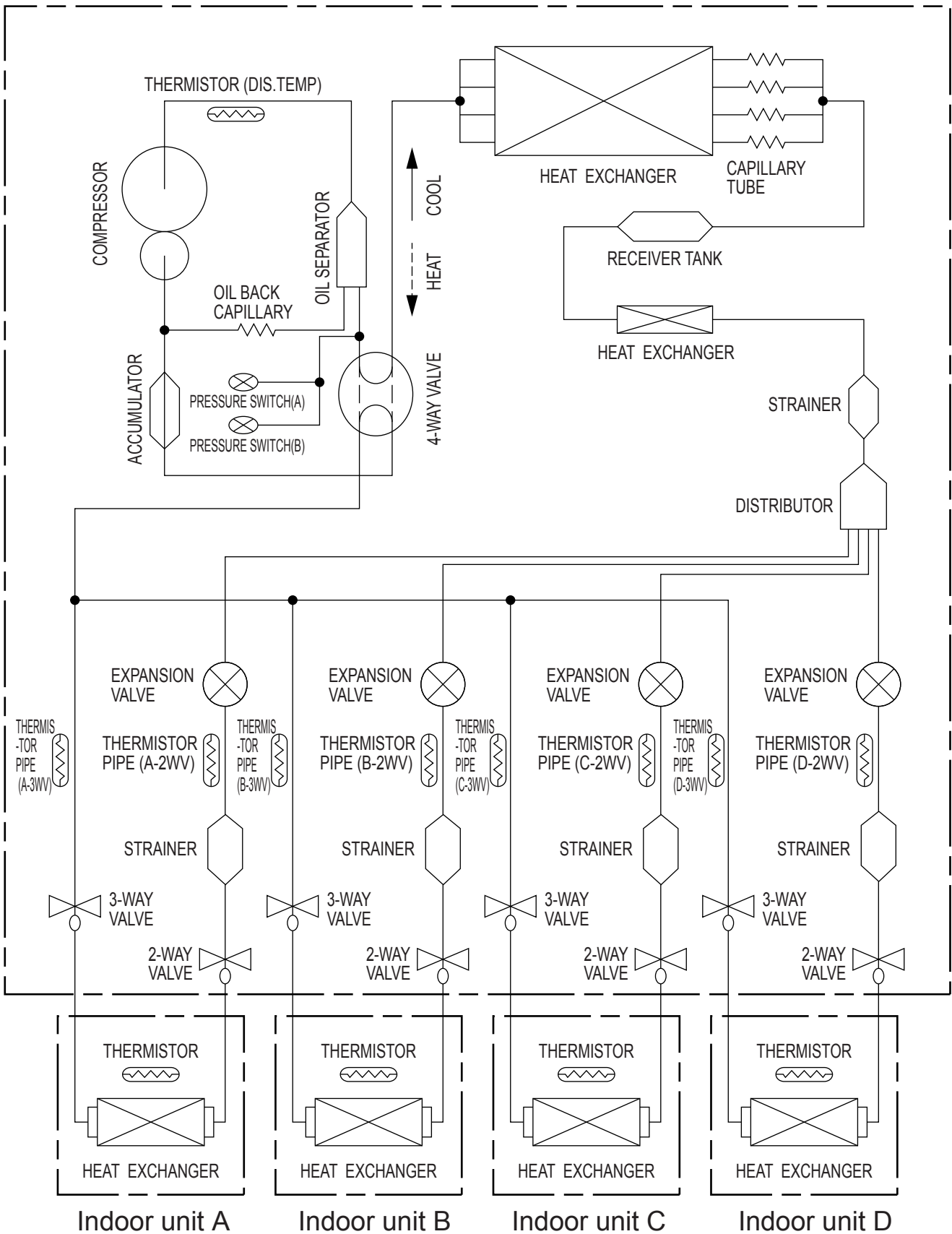

CIRCUIT DIAGRAM

Models : ASH18LBAJ
ASH24LBAJ

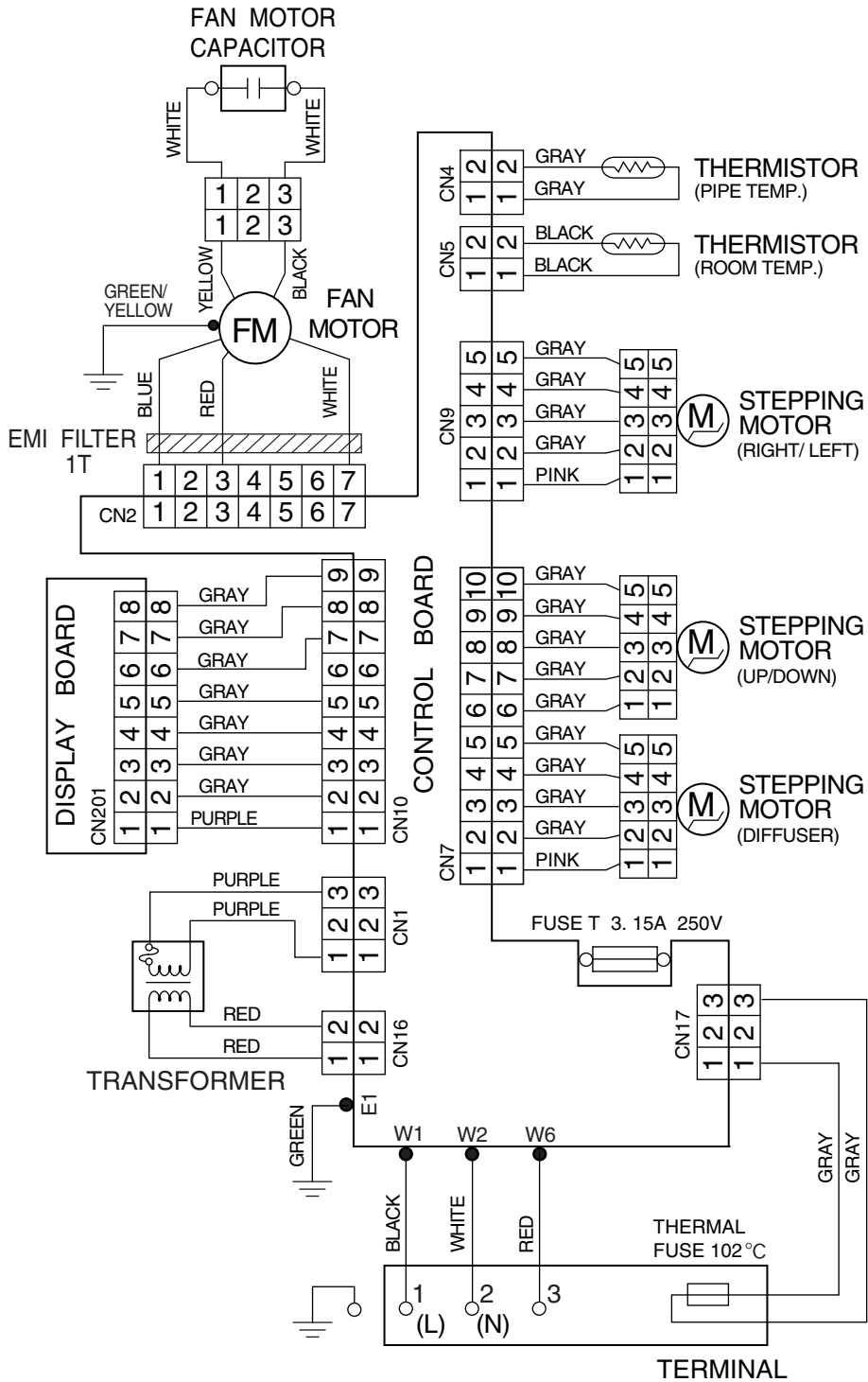

Model : AOH30LMAW4

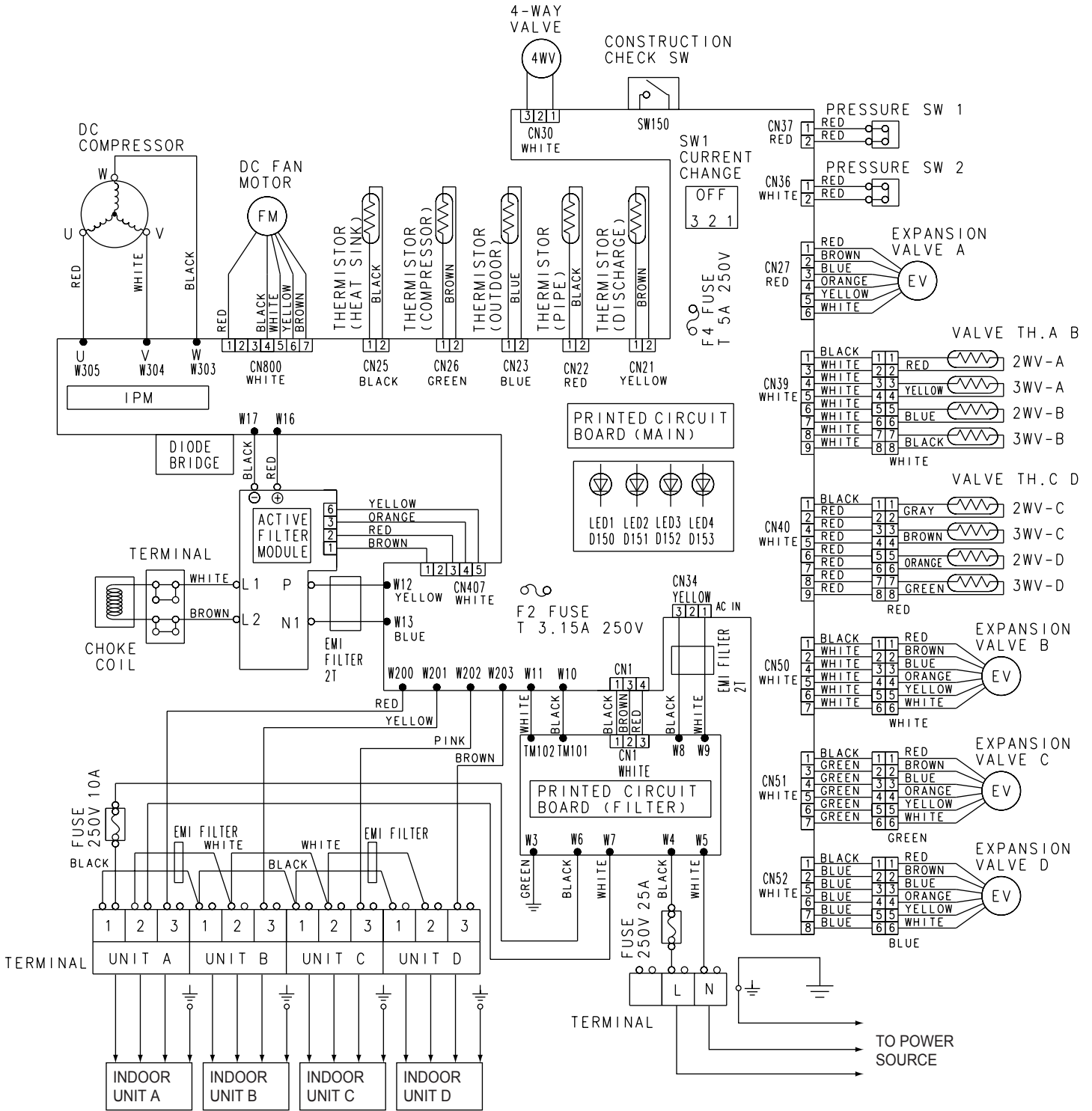

INDOOR PCB CIRCUIT DIAGRAM

Models : ASH18LBAJ
ASH24LBAJ

CONTROLLER PCB ASSEMBLY (MAIN PCB)
ASH18LBAJ : EZ-00319HSE-C
ASH24LBAJ : EZ-0032AHSE-C

INDICATOR PCB
K0401HSE-D0

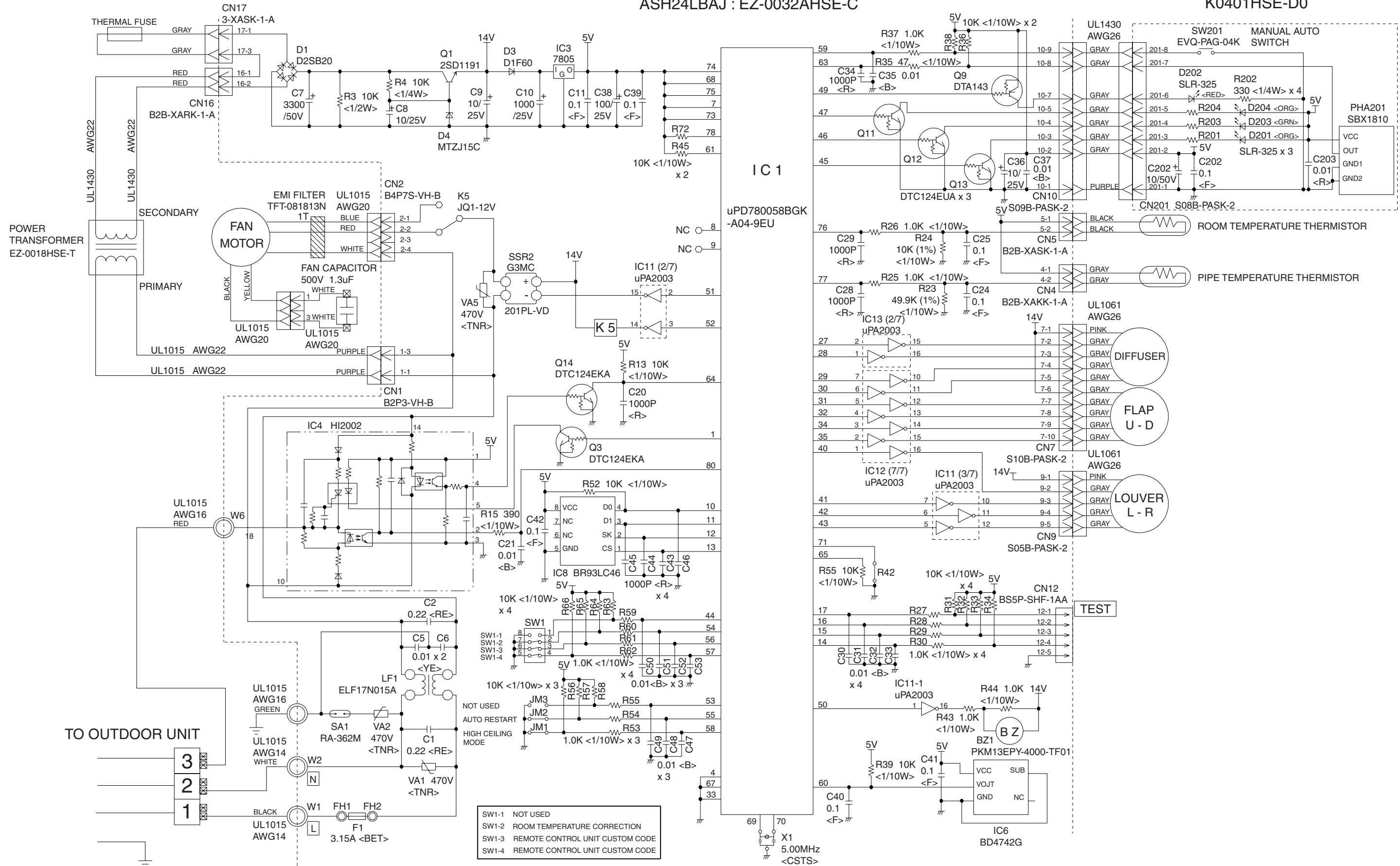

- SW1-1 NOT USED
- SW1-2 ROOM TEMPERATURE CORRECTION
- SW1-3 REMOTE CONTROL UNIT CUSTOM CODE
- SW1-4 REMOTE CONTROL UNIT CUSTOM CODE

OUTDOOR PCB CIRCUIT DIAGRAM

Model : AOH30LMAW4

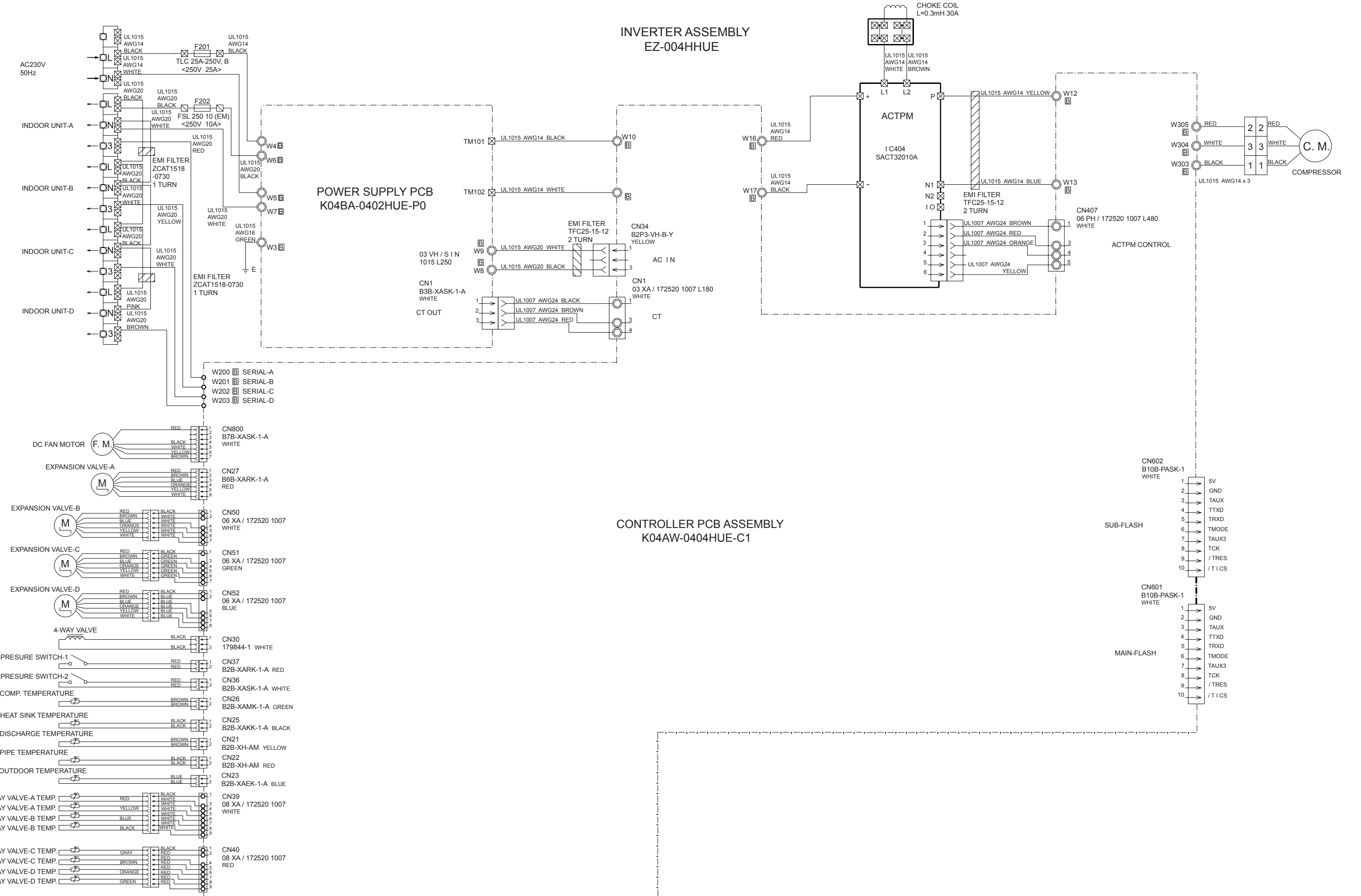

CONTROLLER PCB ASSEMBLY
K04AW-0404HUE-C1

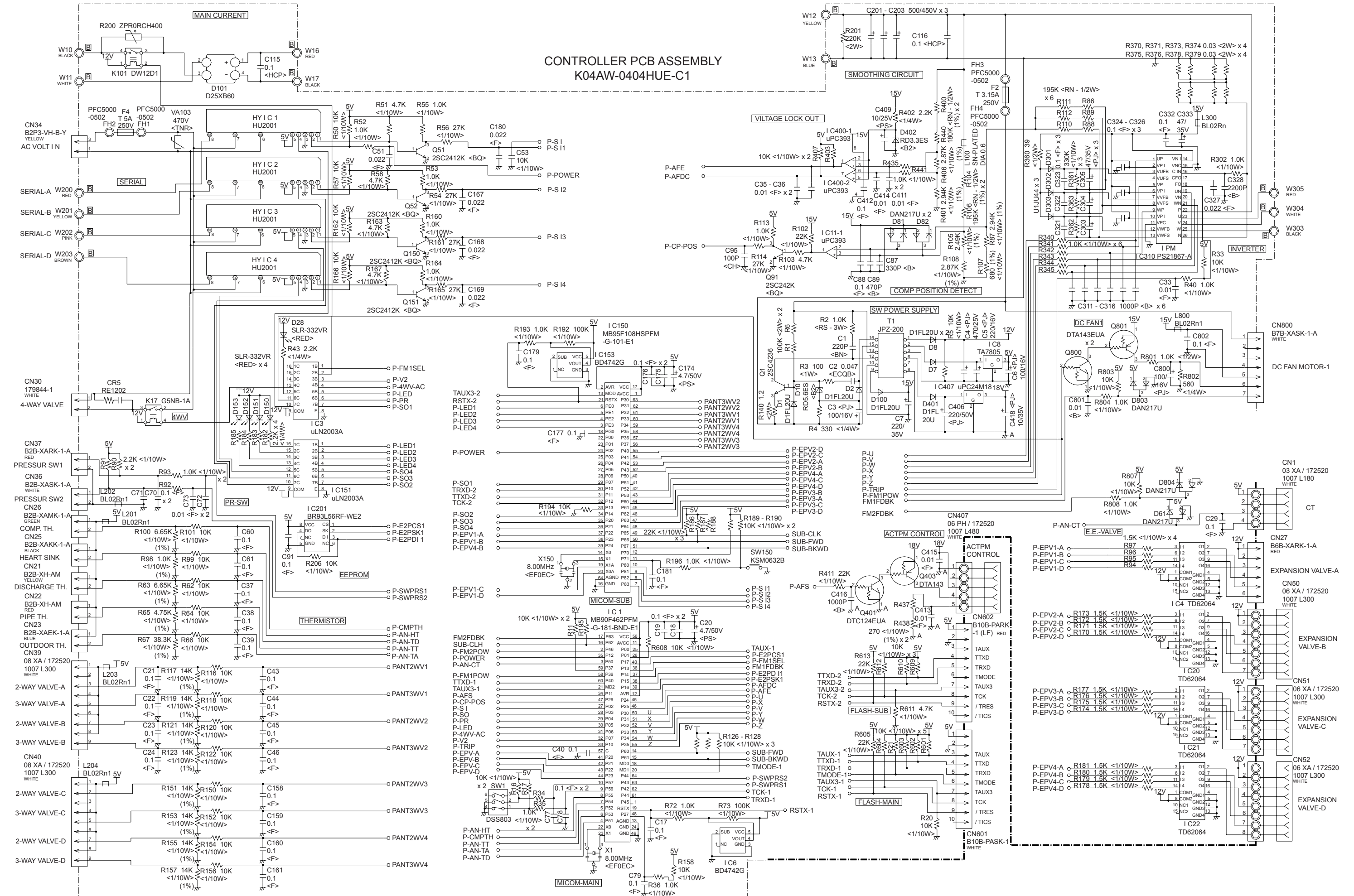

POWER SUPPLY PCB ASSEMBLY
K04BA-0400HUE-P0

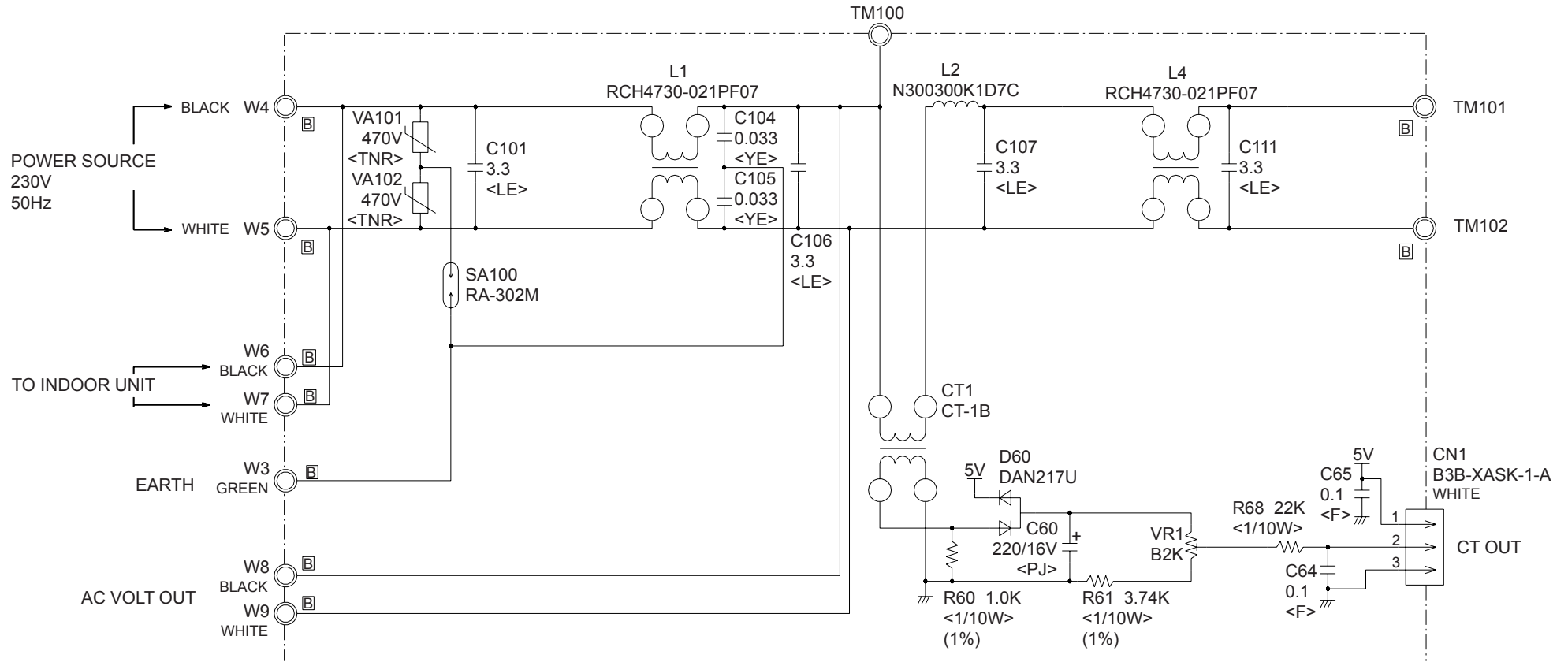

ERROR CONTENTS

The OPERATION, TIMER and SWING lamps operate as follows according to the error contents.

Error contents	Error display		
	OPERATION (RED)	TIMER (GREEN)	SWING (ORANGE)
Indoor unit circuit board error	○	○	—
Indoor unit room temperature sensor wire opened	2 times ●	○	—
Indoor unit room temperature sensor wire short circuited	2 times ●	○	○
Indoor unit piping sensor wire opened	3 times ●	○	—
Indoor unit piping sensor short circuited	3 times ●	○	○
Outdoor unit → Indoor unit communication error	5 times ●	○	—
Indoor unit → Outdoor unit communication error	5 times ●	○	○
Indoor unit fan error	6 times ●	○	—
Outdoor unit heat exchanger temperature sensor error	○	3 times ●	—
Outdoor unit outdoor temperature sensor error	○	4 times ●	—
Outdoor unit discharge temperature sensor error	○	5 times ●	—
Outdoor unit compressor temperature sensor error	○	8 times ●	—
Outdoor unit pressure switch error	○	9 times ●	—
Outdoor unit 2 way valve temperature sensor error	○	—	2 times ●
Outdoor unit 3 way valve temperature sensor error	○	—	3 times ●
Indoor unit fan connection capacity error	○	—	4 times ●
IPM error	○	10 times ●	—
Compressor later location error	○	13 times ●	—
Outdoor fan motor error	○	14 times ●	—

○ : Fast flashing ● : Slow flashing — : Off

DISASSEMBLY ILLUSTRATION

Models : ASH18LBAJ
ASH24LBAJ

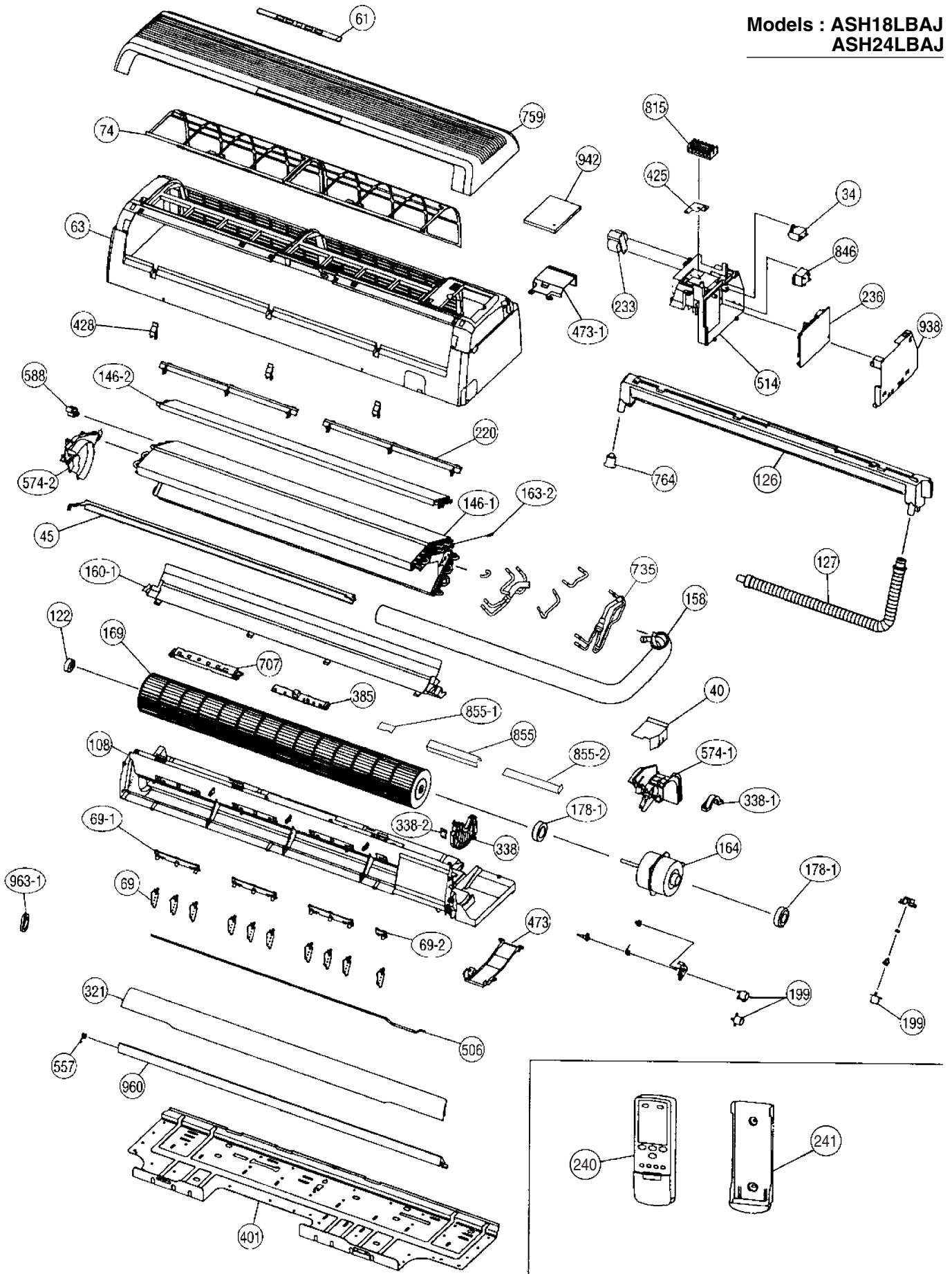

Models : ASH18LBAJ
ASH24LBAJ

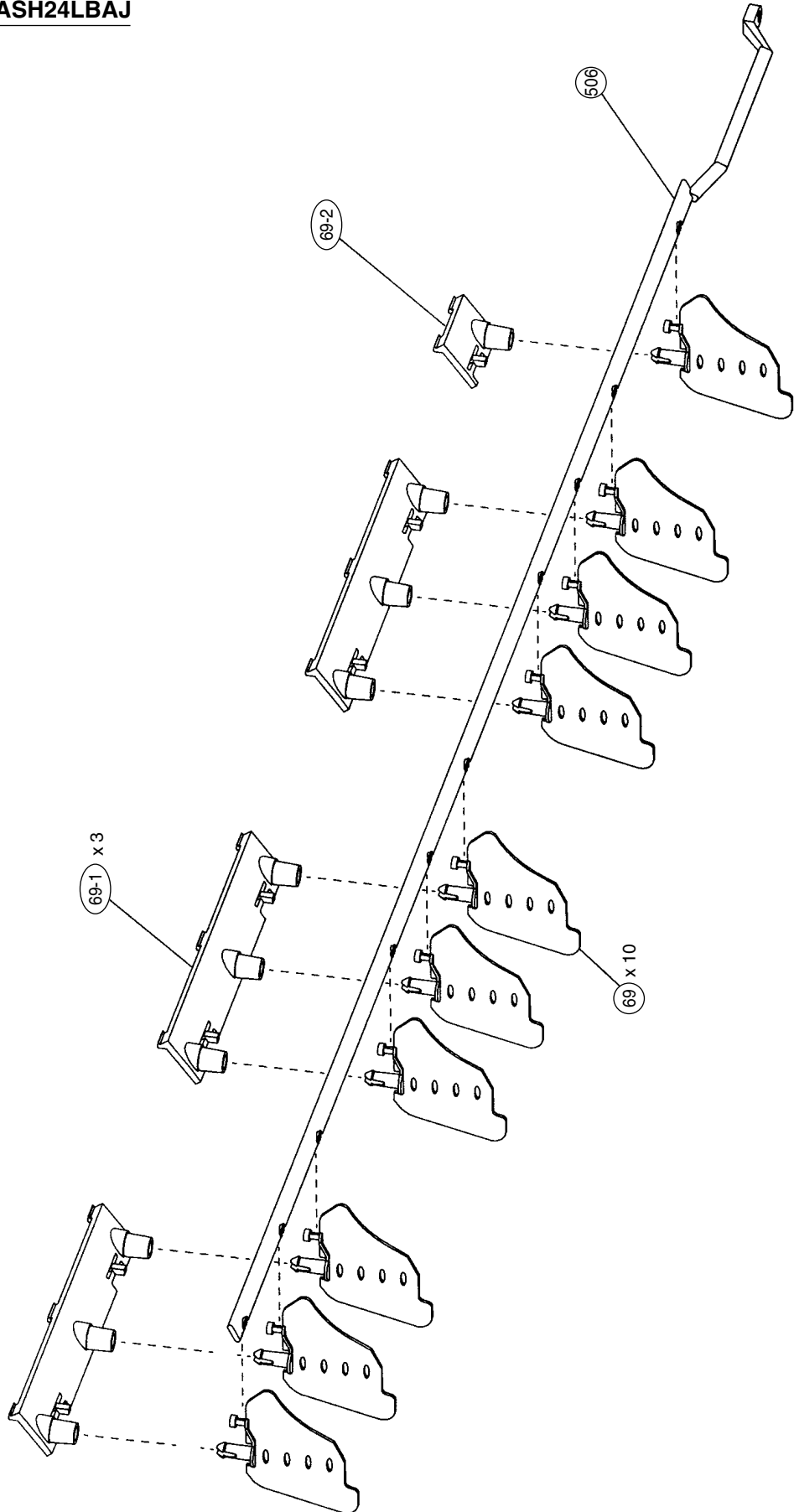

**Models : ASH18LBAJ
ASH24LBAJ**

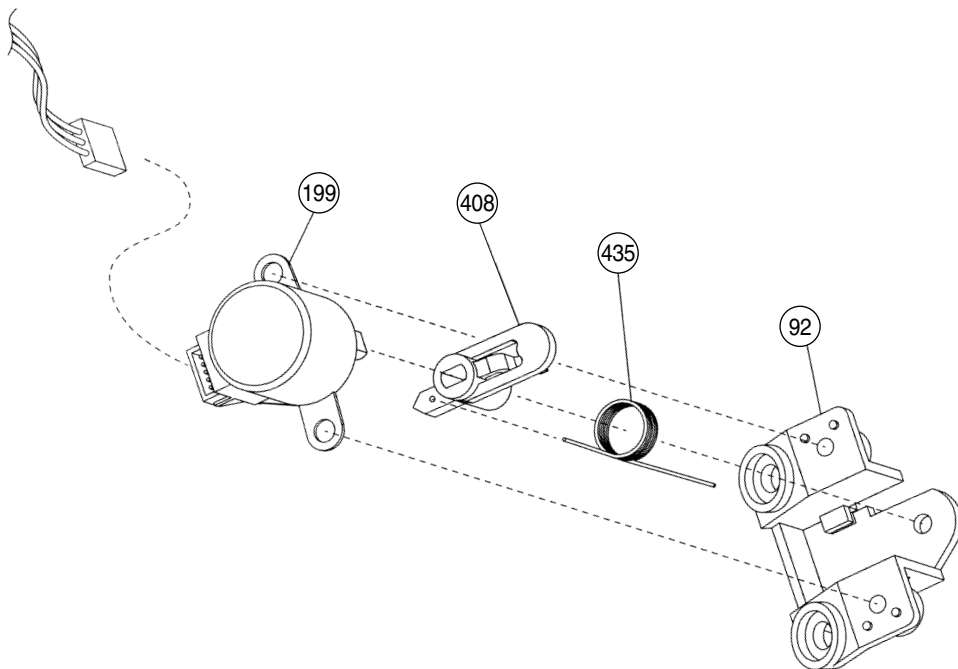
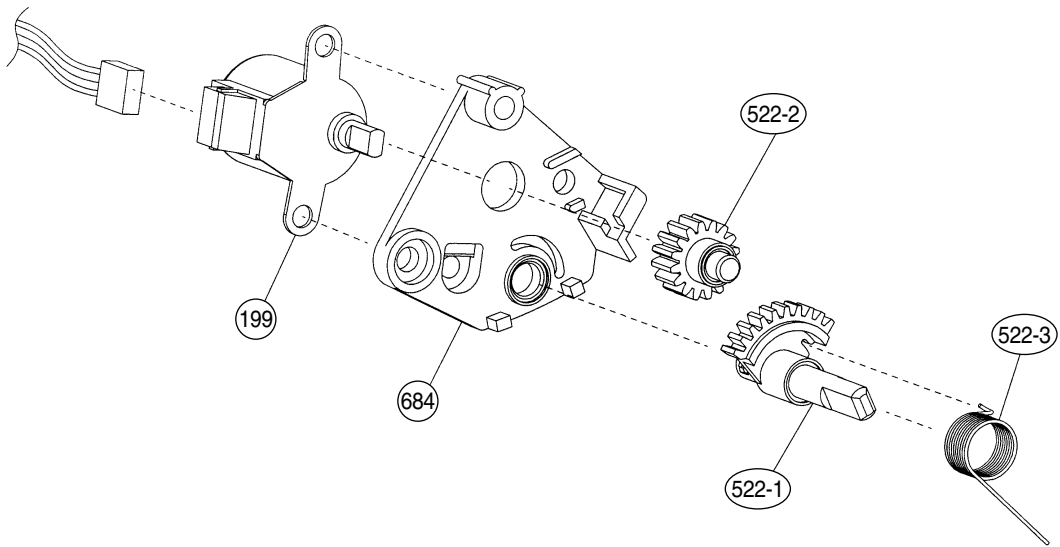

Model : AOH30LMAW4

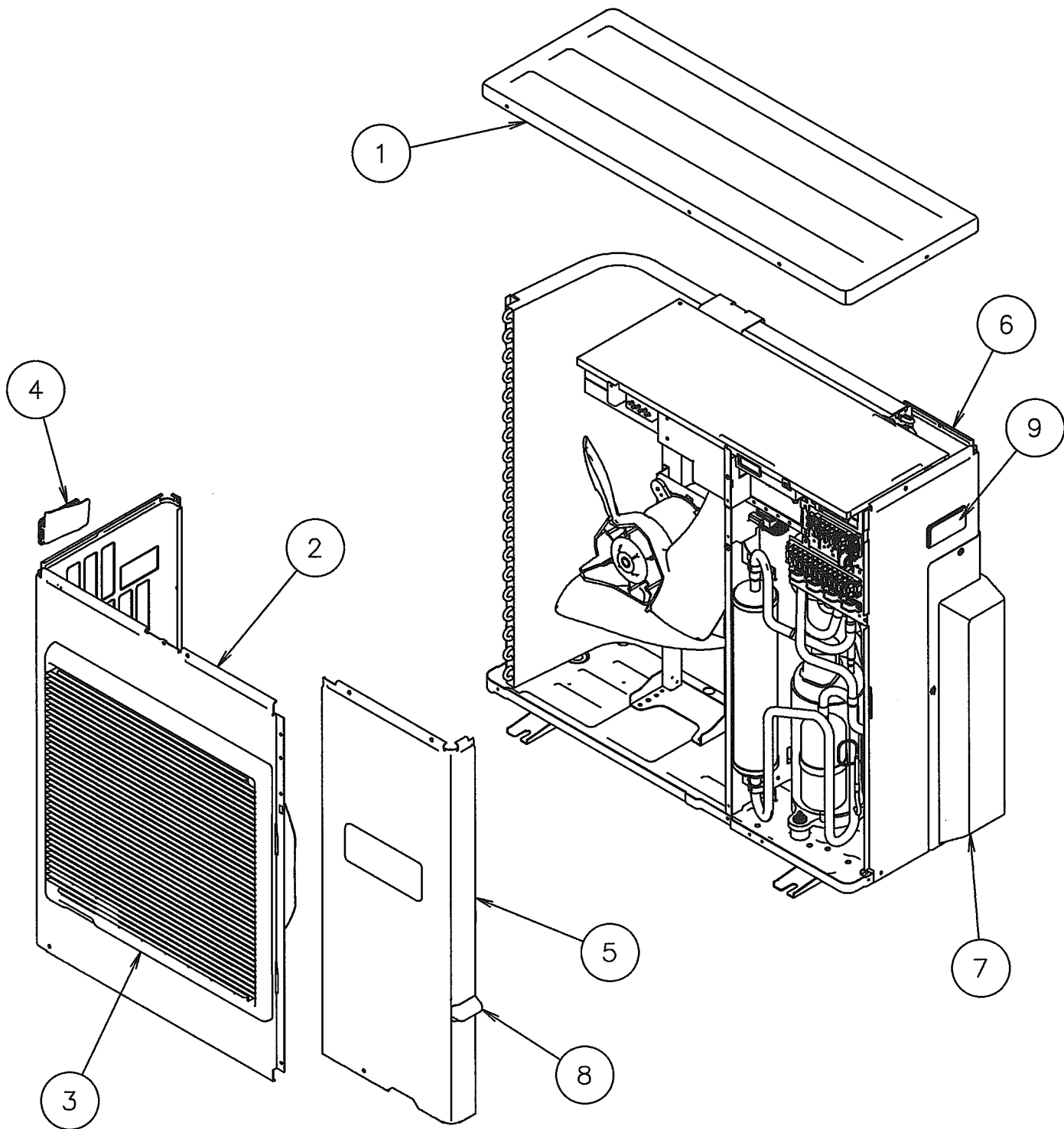

Model : AOH30LMAW4

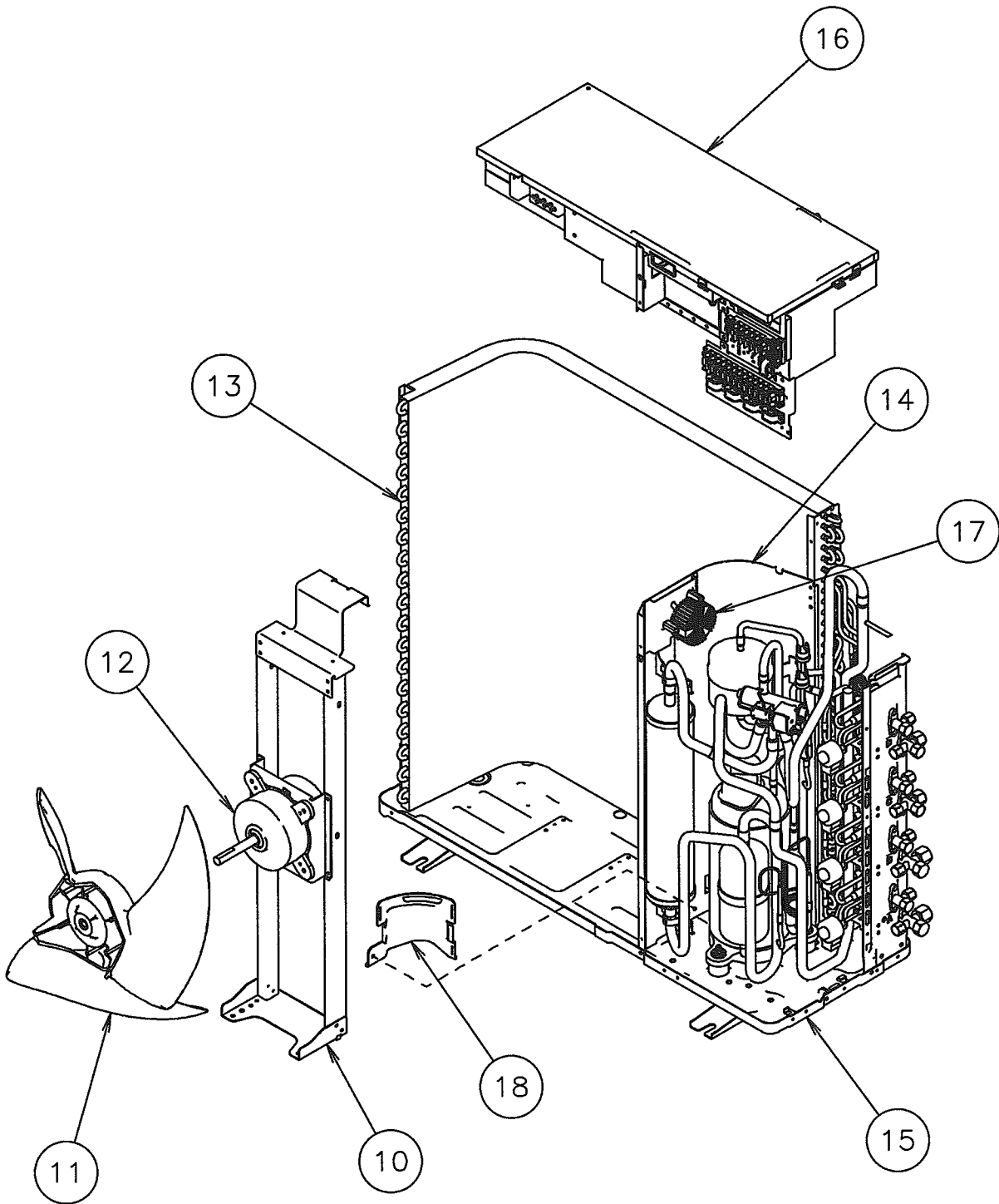

Model : AOH30LMAW4

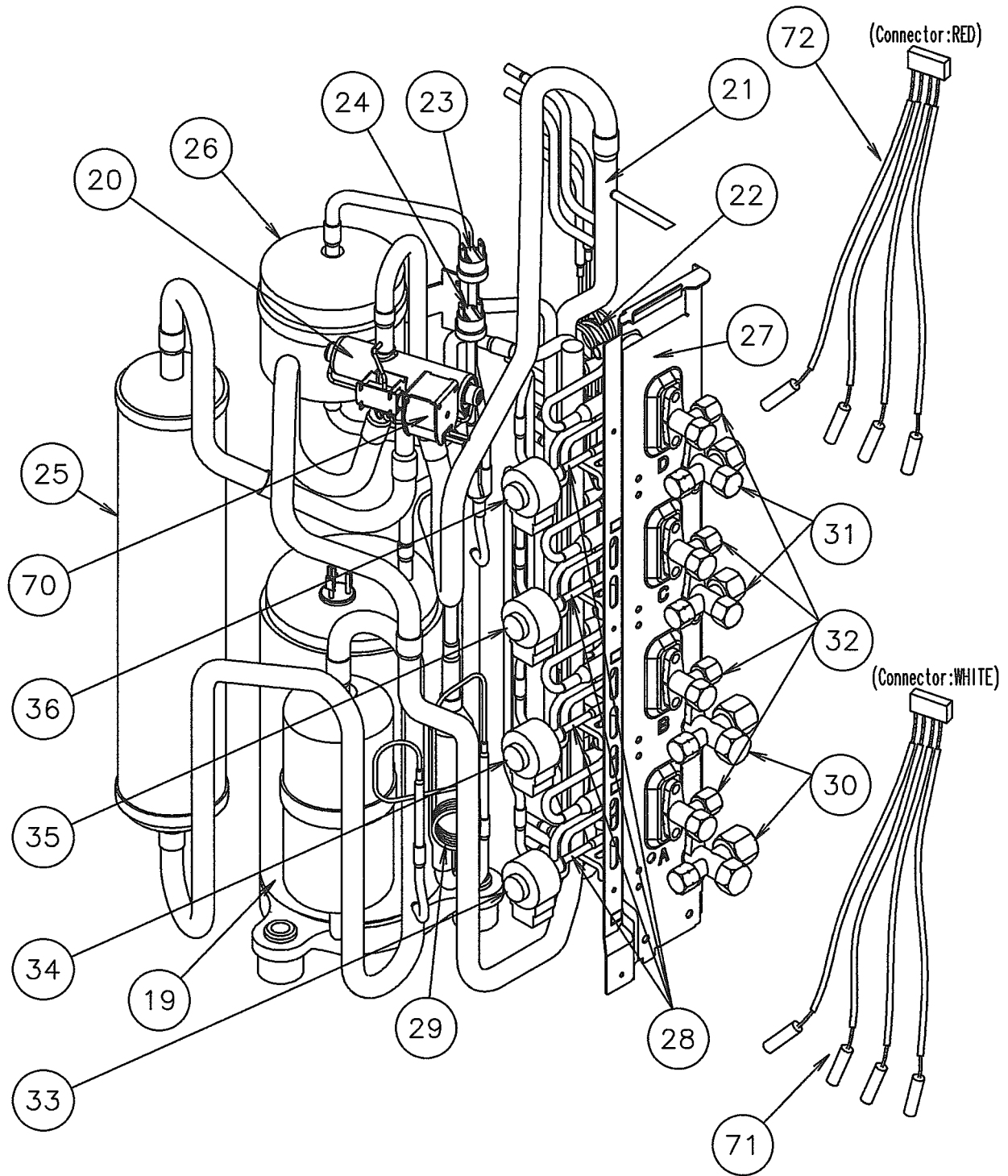

Model : AOH30LMAW4

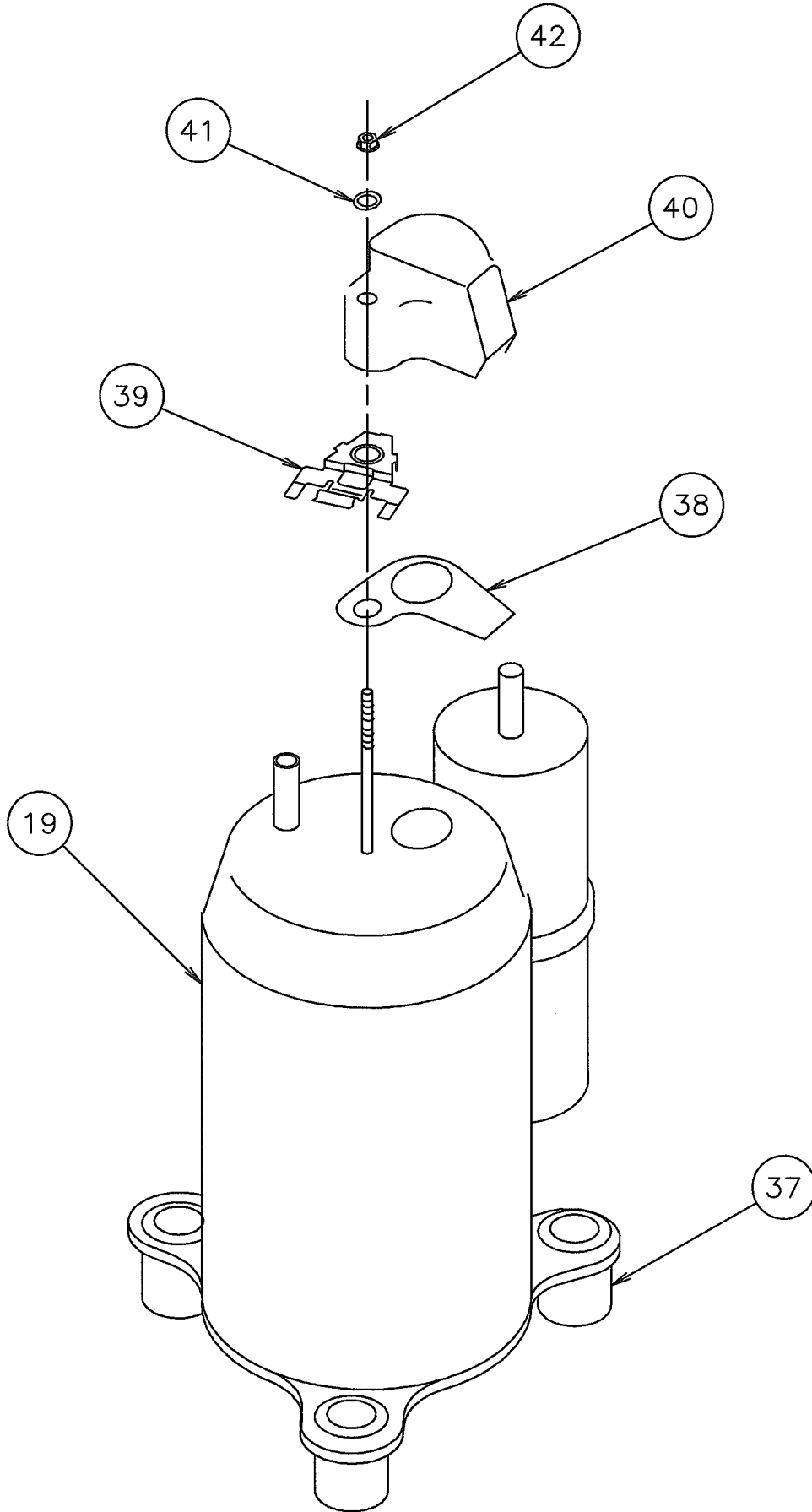

Model : AOH30LMAW4

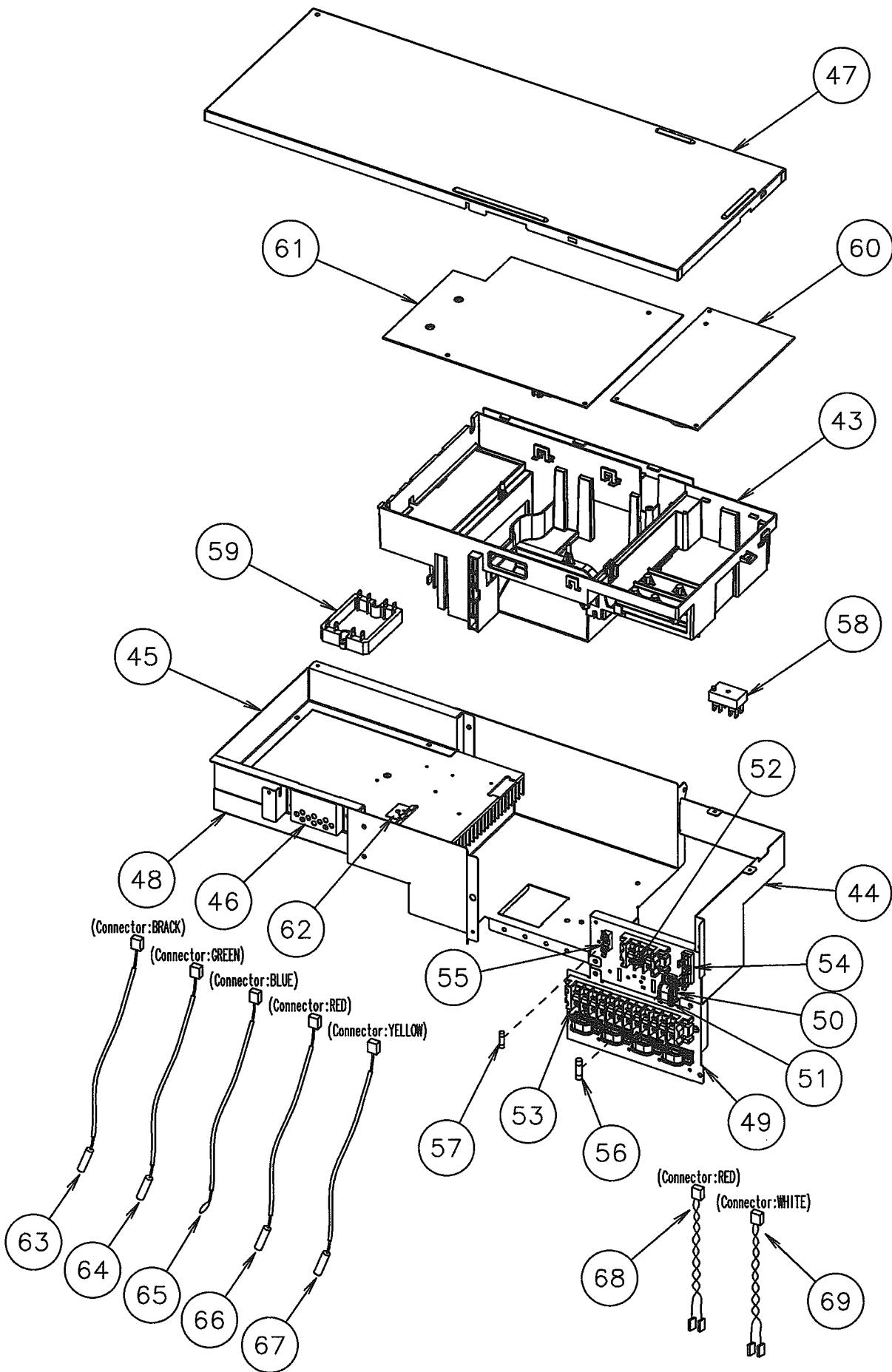

INDOOR UNIT







Ref. No.	Description	Part No.		Ord. Q'ty	Ref. No.	Description	Part No.		Ord. Q'ty
		ASH18LBAJ	ASH24LBAJ				ASH18LBAJ	ASH24LBAJ	
34	Capacitor (Fan Motor)	9704305060	9704305060		338-1	Motor Holder-B	9368551001	9368551001	
40	Water Seal Plate	9369684005	9369684005		338-2	Motor Holder-C	9368769000	9368769000	
45	Bracket (Eva.)	9369372001	9369372001		385	Indicator PCB Assy	9702307011	9702307011	
61	Decoration Plate-F	9368757014	9368757014		401	Wall Hook Bracket	9368579005	9368579005	
63	Front Panel	9368540012	9368540012		408	Louver Link	9368562007	9368562007	
69	Louver	9368560010	9368560010		425	Earth Plate	9368580001	9368580001	
69-1	Louver Base-A	9368558017	9368558017		428	Screw Cover	9368576011	9368576011	
69-2	Louver Base-B	9368559014	9368559014		435	Louver Spring	9368613006	9368613006	
74	Air Filter	9368552008	9368552008		473	Pipe Holder	9368565008	9368565008	
92	Link Holder	9368563004	9368563004		473-1	Cord Holder	9368566005	9368566005	
108	Base	9369209017	9369209017		506	Louver Rod	9368561017	9368561017	
122	Bearing Assy	9368574000	9368574000		514	Control Box	9368543006	9368543006	
126	Front Drain Pan	9370932010	9370932010		522-1	Sector Gear	9368556006	9368556006	
127	Drain Hose	9367695003	9367695003		522-2	Pinion Gear	9368557003	9368557003	
146-1	Evaporator-A Assy	9372102015	9373721017		522-3	Flap Spring	9368612009	9368612009	
146-2	Evaporator-B Assy	----	9369373008		557	Diffuser Spring	9368587000	9368587000	
158	Joint Pipe Assy	9370301007	9370301007		574-1	Evaporator Support-R	9368549008	9368549008	
160-1	Rear Drain Pan	9368547004	9368547004		574-2	Evaporator Support-L	9368548001	9368548001	
163-2	Thermistor Spring-A	313728262708	313728262708		588	Evaporator Holder	----	9368775001	
164	Fan Motor Assy-IN	9601388012	9601388012		684	Motor Base	9368555009	9368555009	
169	Cross Flow Fan Assy	9368586003	9368586003		707	Display Cover	9368564001	9368564001	
178-1	Rubber (Motor)	9368575007	9368575007		735	Distributor Assy	9373249016	9373249016	
199	Step Motor	9900020019	9900020019		759	Intake Grill-G	9368542030	9368542030	
220	Water Plate	9368569006	9368569006		764	Drain Cap	9367677009	9367677009	
233	Power Transformer	9900069018	9900069018		815	Terminal	9306489106	9306489106	
236	Controller PCB Assy	9704714091 (EZ-00319HSE-C)	9704714107 (EZ-0032AHSE-C)		846	Relay G5NB-1A	9900007010	9900007010	
240	Remote Control Unit	9371190112	9371190112		855	Cover Display	9369264016	9369264016	
241	Remocon Holder	9305642014	9305642014		855-1	Cover Display-B	9369594014	9369594014	
321	Flap	9368544010	9368544010		855-2	Cover Display-C	9369683015	9369683015	
338	Motor Holder-A	9368550004	9368550004		938	Control Box Cover-R	9369631009	9369631009	
					942	Control Box Cover	9368611002	9368611002	
					960	Diffuser Assy	9368545017	9368545017	
					963-1	Fan Guard Holder	9368554002	9368554002	
					---	Room thermister	9703299179	9703299179	
					---	Pipe thermister	9703297076	9703297076	

OUTDOOR UNIT

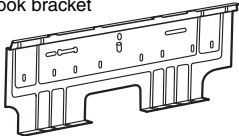
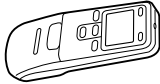
Ref. No.	Description	Part No.	Ord. Q'ty	Ref. No.	Description	Part No.	Ord. Q'ty
		AOH30LMAW4				AOH30LMAW4	
1	Top Panel Sub Assy	9374417025		41	Washer (Rubber)	9358078006	
2	Front Panel M	9374094066		42	Frang Nut	9358079003	
3	Fan Guard	9374330010		43	Inverter Box A	9374603015	
4	Grip Side	9374173013		44	Inverter Box B Assy	9374625017	
5	Service Panel M	9374093069		45	Inverter Box C	9374605019	
6	Right Panel M	9374599028		46	Inverter Box Duct	9374609017	
7	Valve Cover Sub Assy	9374827015		47	Inverter Box Cover	9374608010	
8	Grip Service	9374171019		48	Heat Sink A	9374607013	
9	Grip	9374172016		49	Inverter Box D	9374606016	
10	Motor Bracket Sub Assy	9374418053		50	Clamp (Cord) C	9359677000	
11	Propeller Fan Assy	9366378020		51	Clamp (Cord)	9356857009	
12	Motor. DC Brushless	9601882015		52	Terminal (3P)	9900203016	
13	Condenser A Assy	9374433056		53	Terminal (12P)	9358660164	
14	Separate Wall Assy S	9374629022		54	Fuse Holder (Big)	0501454012	
15	Base Assy	9374166084		55	Fuse Holder (Small)	0501456016	
16	Inverter Assy	9705824010		56	Fuse (Big)	0600086039	
17	Coil. Choke	9703458019		57	Fuse (Small)	0600376116	
18	Cap Foot	9374345014		58	Terminal	9701971015	
19	Compressor Sub Assy	9374423064		59	ACTPM	9703457012	
20	4-Way Valve Assy	9374425044		60	PWB Assy (Power Supply)	9705647039	
21	Inlet Pipe (Cond) A Assy	9373461067		61	PWB Assy (Controller)	9705642058	
22	Outlet Pipe (Cond) A Assy	9374266067		62	Holder (Thermo)	9372797013	
23	Pressure Switch A Assy	9367726028		63	Heat Sink Thermistor	9900311018	
24	Pressure Switch B Assy	9367727025		64	Compressor Temp Thermistor	9900156022	
25	Accumulator Sub Assy	9374426072		65	Thermistor (Outdoor Temp)	9703516078	
26	Receiver Tank Sub Assy	9373426028		66	Heat Exchanger Thermistor	9704220059	
27	Valve Plate A Assy	9374628025		67	Discharg Temp Thermistor	9704219114	
28	Expansion Valve Assy	9370947106		68	Wire (Pressure Sw)(Red)	9367595037	
29	Capillary Assy	9372197370		69	Wire (Pressure Sw)(White)	9367595044	
30	3-Way Valve Assy (1/2")	9372205051		70	Solenoid	9900165055	
31	3-Way Valve Assy (3/8")	9372205044		71	Thermistor (Pipe)(White)	9900322014	
32	2-Way Valve Assy	9372204054		72	Thermistor (Pipe)(Red)	9900289010	
33	Coil (Expansion Valve)(A=Red)	9900057084		---	Emblem Rear	9372171011	
34	Coil (Expansion Valve)(B=White)	9900057053					
35	Coil (Expansion Valve)(C=Green)	9900057060					
36	Coil (Expansion Valve)(D=Blue)	9900057077					
37	Rubber Seat (For Comp)	9358080009					
38	Gasket	9370290004					
39	Holder	9372066010					
40	Terminal Cover (Comp)	9370289008					

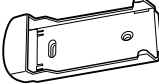
STANDARD ACCESSORIES

INDOOR UNIT ACCESSORIES

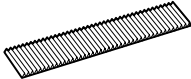
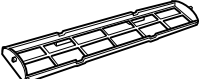
Name and Shape	Part No.
Wall hook bracket 	9368579005
Remote control unit 	9371190112
Battery (penlight) 	0600185534
Remote control unit holder 	9305642014
Tapping screw (big) (ø4 x 20) 	301141164200
Tapping screw (big) (ø4 x 12) 	301171164129
Tapping screw (small) (ø3 x 12) 	301141533125
Air cleaning filter 	DEODORANT FILTER 9370525007 ELECTRIC FILTER 9370528015
Air cleaning filter frame 	9368568009

0504G2831