



**INVERTER MULTI  
AIR CONDITIONER  
FLOOR CONSOLE /  
UNDER CEILING  
DUAL type**

**SERVICE  
MANUAL**



**Models**

**Indoor unit**

**Outdoor unit**

ABH14LBAJ	}	AOH30LMAW4
ABH18LBAJ		
ABH24LBAJ		

**CONTENTS**

SPECIFICATIONS .....	1
OUTLINE AND DIMENSIONS .....	3
REFRIGERANT SYSTEM DIAGRAM .....	5
CIRCUIT DIAGRAM .....	6
INDOOR PCB CIRCUIT DIAGRAM .....	8
OUTDOOR PCB CIRCUIT DIAGRAM .....	9
ERROR CONTENTS .....	12
DISASSEMBLY ILLUSTRATION .....	13
PARTS LIST .....	25

## SPECIFICATIONS

<b>TYPE</b>	Cool and Heat		
<b>INDOOR UNIT</b>	<b>ABH14LBAJ</b>	<b>ABH18LBAJ</b>	<b>ABH24LBAJ</b>

### ELECTRICAL DATA

<b>POWER SOURCE</b>	(V)	230		
<b>FREQUENCY</b>	(Hz)	50		
<b>AIR CIRCULATION-HI</b>	(m <sup>3</sup> /hr)	640	780	880

### FAN MOTOR

<b>POWER SOURCE</b>	(V)	230		
<b>INDOOR UNIT</b>	<b>DISCRIMINATION</b>	<b>MFA-14JTT</b>	<b>MFA-18JTT</b>	<b>MFA-24JTT</b>
	<b>HI-SPEED</b> (r.p.m.)	850	1,030	1,180
	<b>MED-SPEED</b> (r.p.m.)	760	890	1,040
	<b>LO-SPEED</b> (r.p.m.)	670	770	900

<b>DIMENSIONS</b>	H x W x D	(mm)	199 x 990 x 655	
<b>WEIGHT</b>	GROSS / NET	(kg)	37 / 28	

## OUTDOOR UNIT

TYPE	Cooling & Heating	
MODEL NAME	<b>AOH30LMAW4</b>	
COOLING CAPACITY	(kW)	8.0
HEATING CAPACITY	(kW)	9.6

### ELECTRICAL SPECIFICATIONS

POWER SUPPLY	(V)	(220) - 230 - (240)	
FREQUENCY	(Hz)	50	
RUNNING CURRENT	(A)	COOLING	9.7
		HEATING	10.5
INPUT	(kW)	COOLING	2.22
		HEATING	2.40
EER	(kW/kW)	COOLING	3.60
		HEATING	4.00
AIR CIRCULATION - Hi	(m <sup>3</sup> /hr)	3,300	

### COMPRESSOR

TYPE	Hermetic type, Inverter, 4 poles, 3-phase, DC motor, Twin Rotary		
DISCRIMINATION	TNB220FPBM9		
REFRIGERANT	R410	(g)	3,300

### FAN MOTOR

DISCRIMINATION	MFE-60PO		
HI-SPEED (COOL / HEAT)	(r.p.m.)	820 / 780	

DIMENSIONS	H x W x D	(mm)	830 x 900 x 330
WEIGHT	NET / GROSS	(kg)	68 / 78

### REFRIGERANT CHARGE (R410A)

FULL CHARGE AMOUNT	Total Pipe Length	50.0 m	3,300 g
		60.0 m	3,550 g
		70.0 m	3,800 g
ADDITIONAL CHARGE			25 g / m
CHARGELESS			50 m
MAX PIPE LENGTH (each unit)			25 m
MAX PIPE LENGTH (total)			70 m
MAX ELEVATION (between indoor units)			10 m
MAX ELEVATION (between indoor and outdoor units)			10 m
MIN. PIPE LENGTH (each unit)			5 m

# OUTLINE AND DIMENSIONS

Unit : mm

## INDOOR UNIT

Models : ABH14LBAJ, ABH18LBAJ, ABH24LBAJ

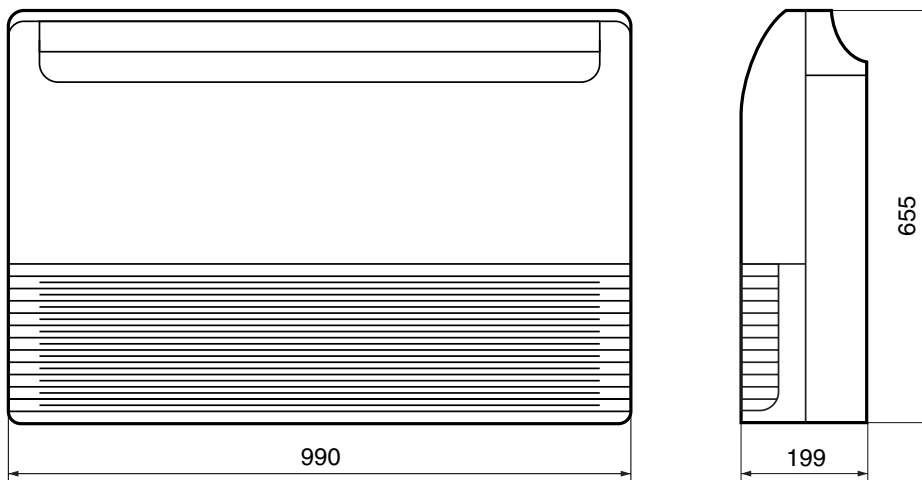

**(rear view)**

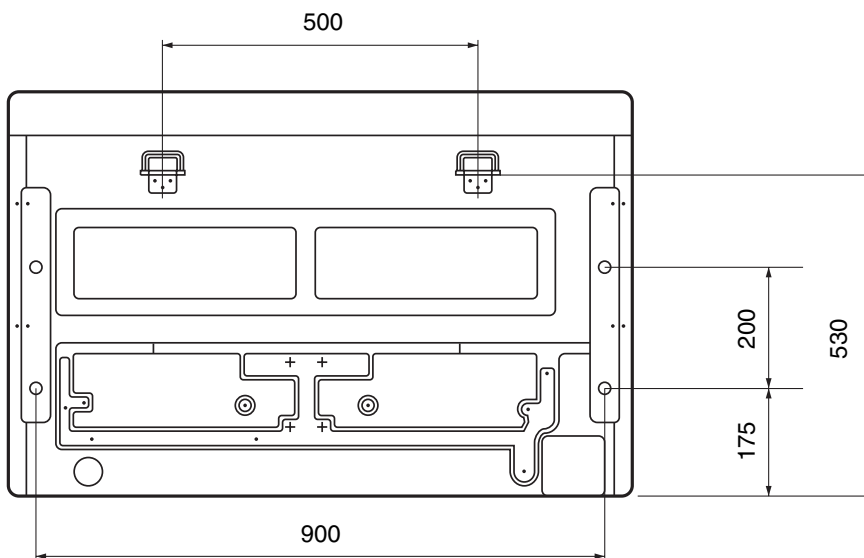

**OUTDOOR UNIT (Unit : mm)**

**Model : AOH30LMAW4**

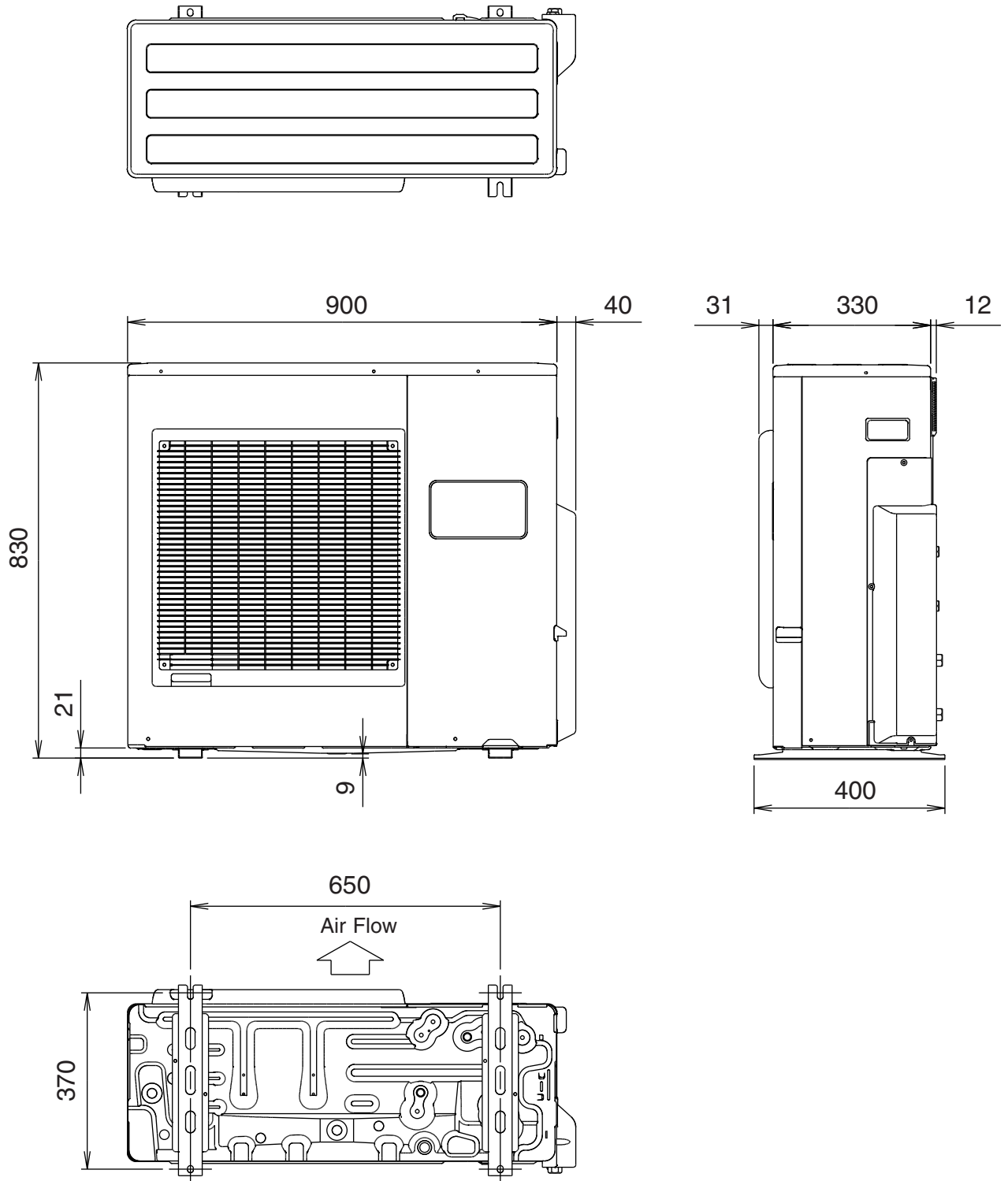

# REFRIGERANT SYSTEM DIAGRAM

## Outdoor unit

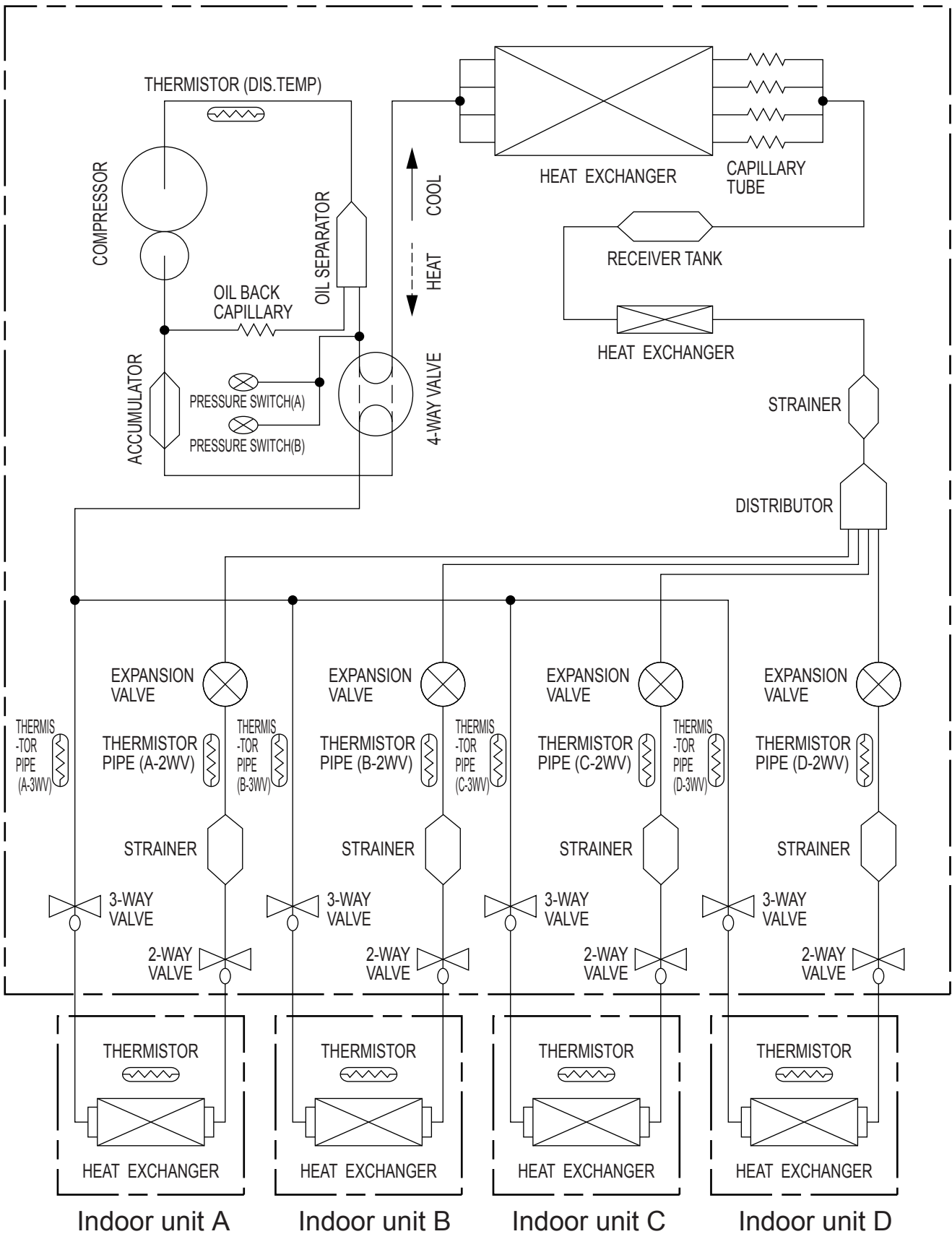

# CIRCUIT DIAGRAM

Models : ABH14LBAJ  
 ABH18LBAJ  
 ABH24LBAJ

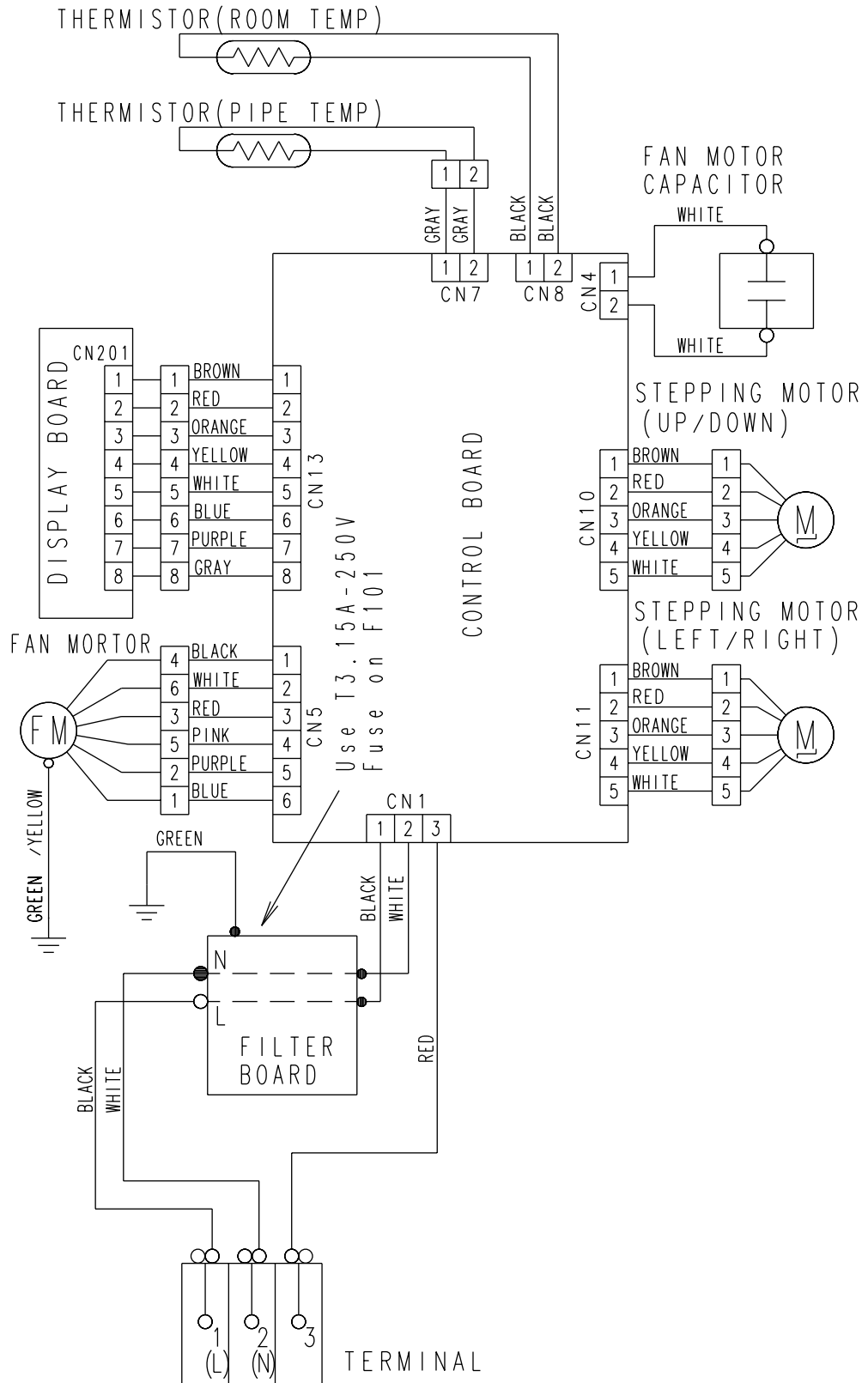

**Model : AOH30LMAW4**

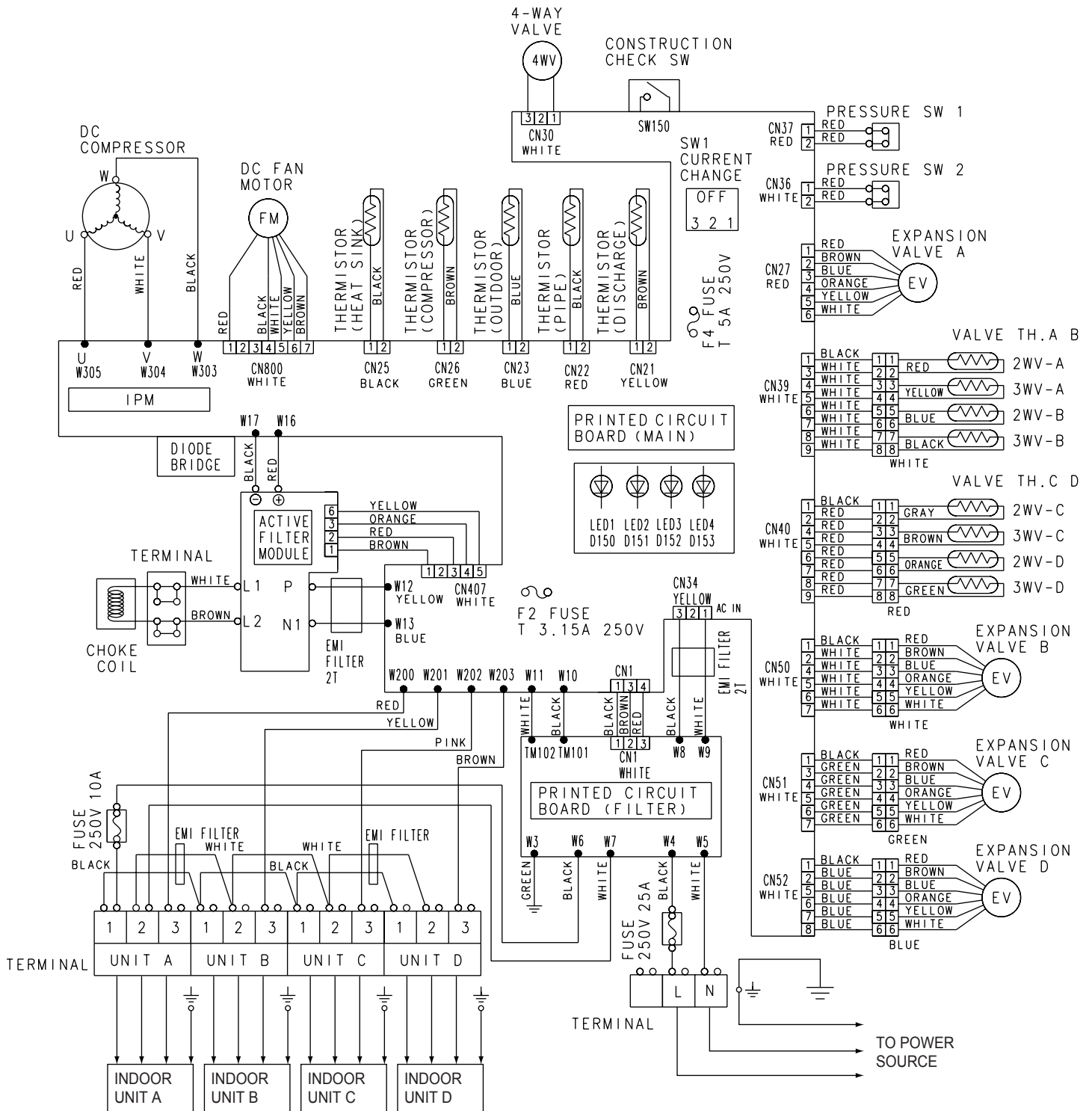



# INDOOR PCB CIRCUIT DIAGRAM

Models : ABH14LBAJ  
ABH18LBAJ  
ABH24LBAJ

## CONTROLLER PCB ASSY ( MAIN PCB )

ABH14LBAJ : K01AL-0414HSE-C1  
ABH18LBAJ : K01AL-040DHSE-C1  
ABH24LBAJ : K01AL-0408HSE-C1

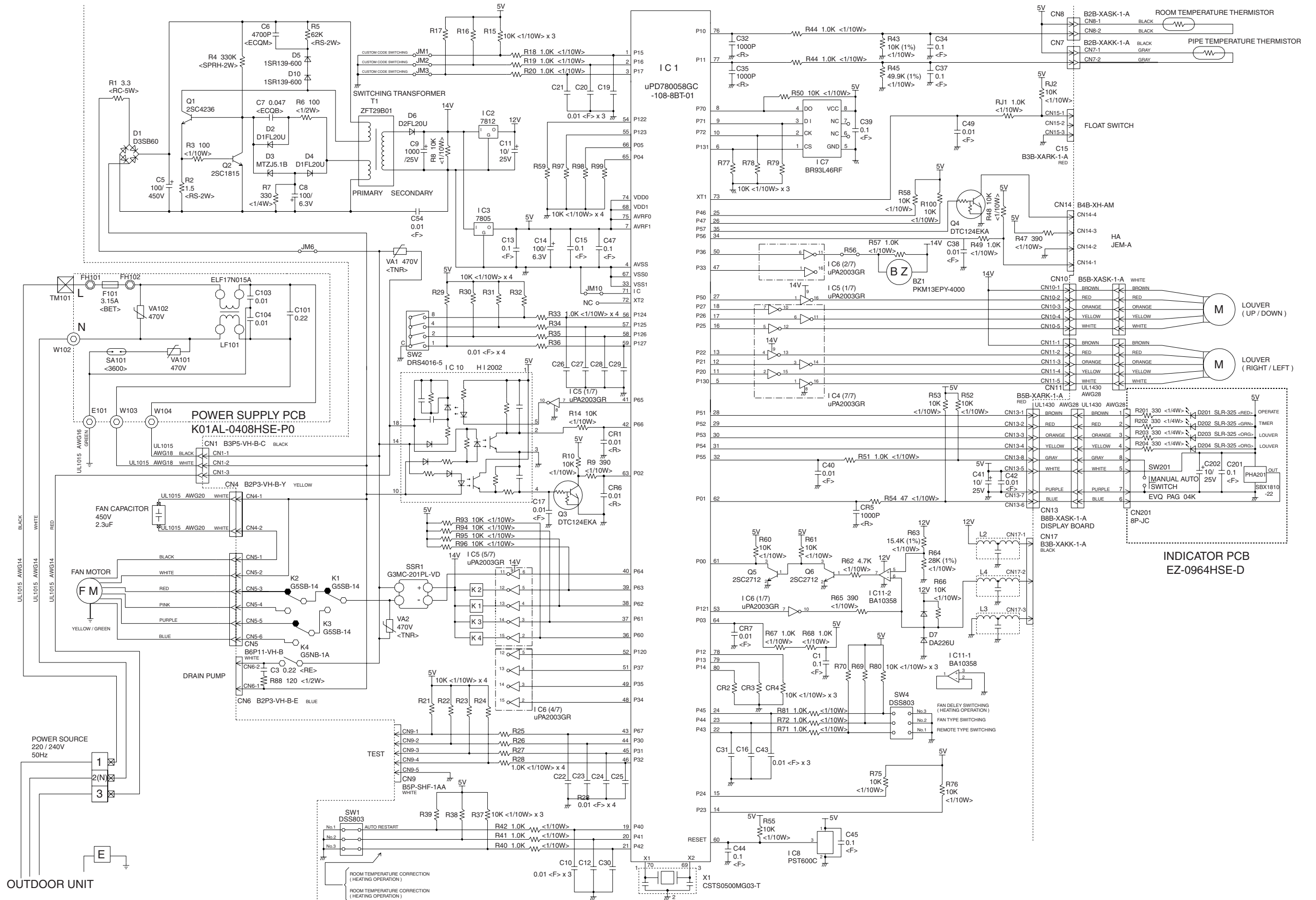

# OUTDOOR PCB CIRCUIT DIAGRAM

Model : AOH30LMAW4

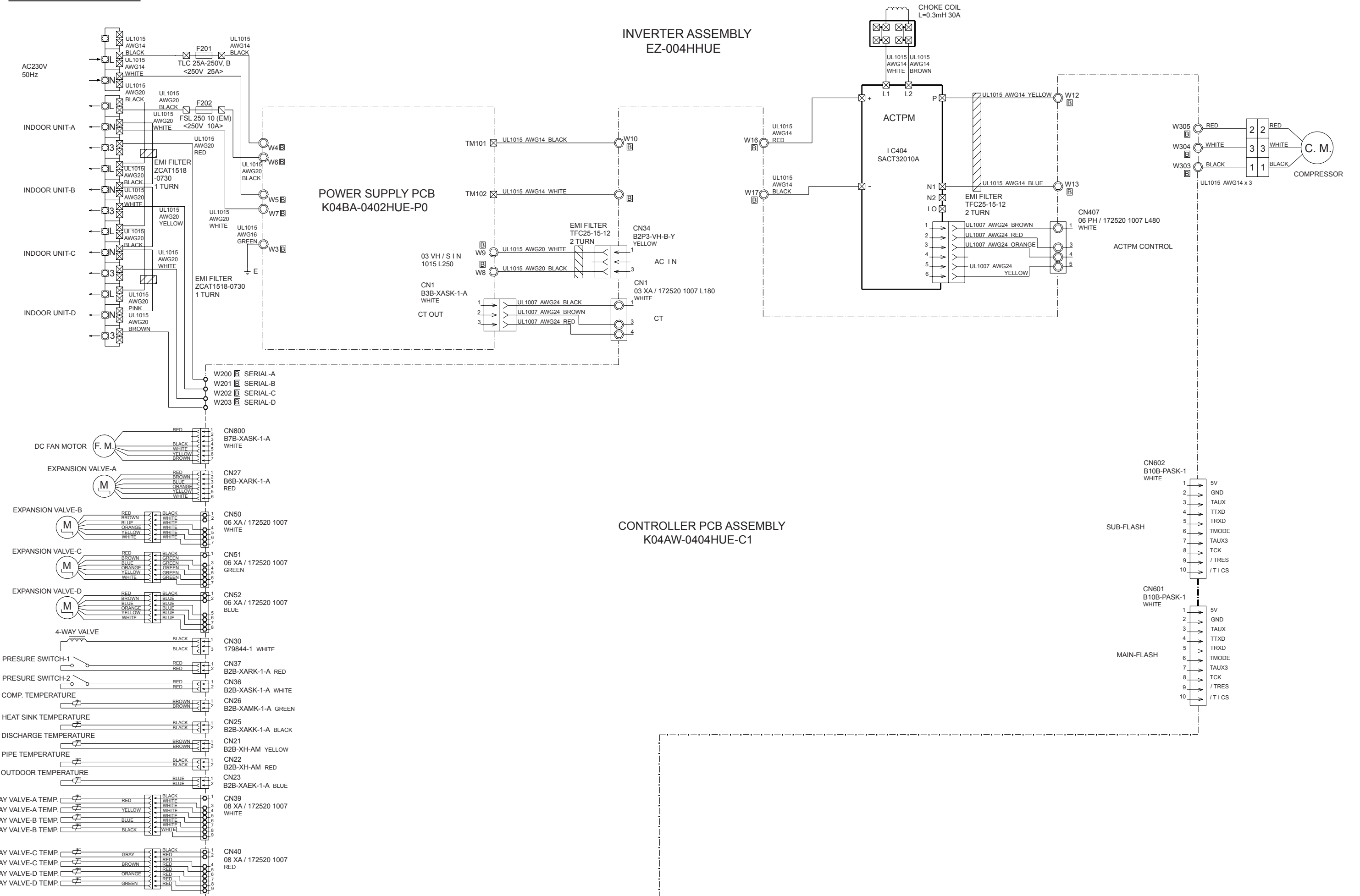



**Model : AOH30LMAW4**

**POWER SUPPLY PCB ASSEMBLY  
K04BA-0400HUE-P0**

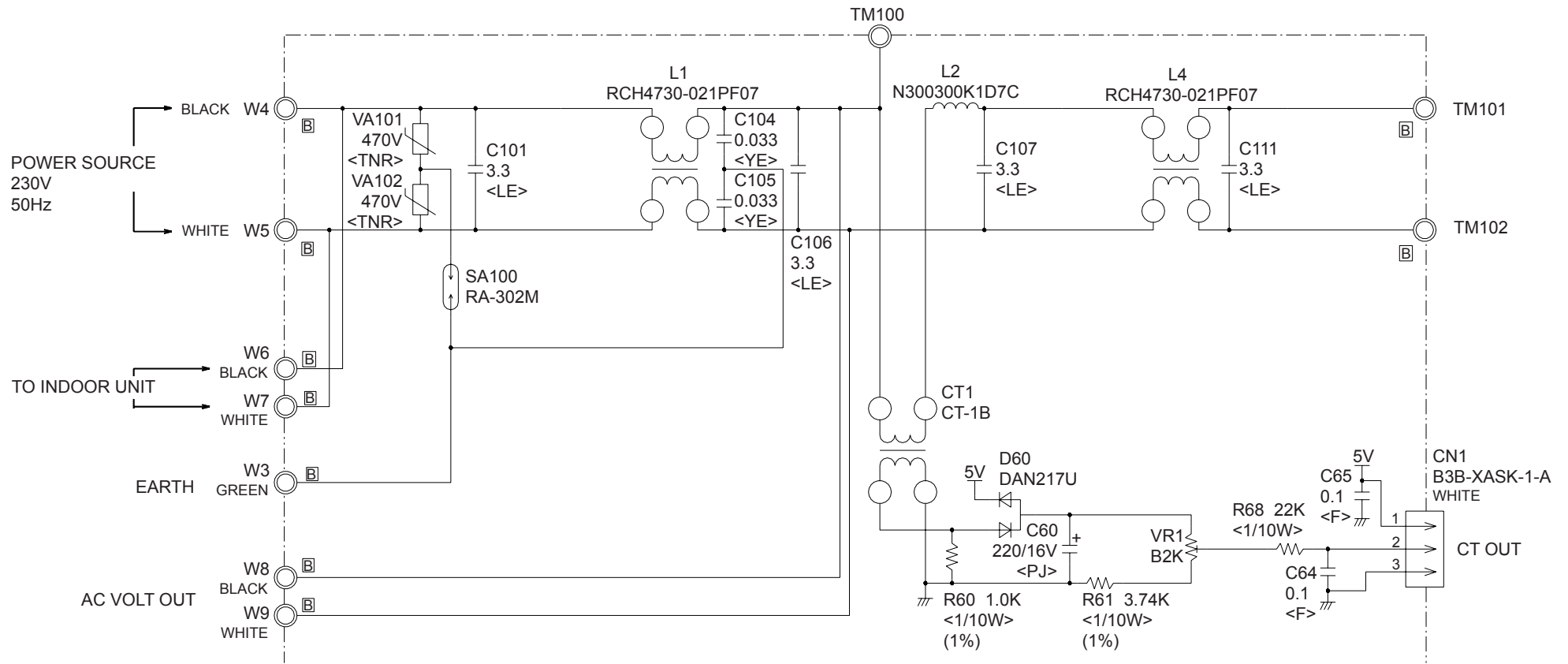

# ERROR CONTENTS

The OPERATION, TIMER and SWING lamps operate as follows according to the error contents.

Error contents	Error display		
	OPERATION (RED)	TIMER (GREEN)	SWING (ORANGE)
Indoor unit circuit board error	○	○	—
Indoor unit room temperature sensor wire opened	2 times ●	○	—
Indoor unit room temperature sensor wire short circuited	2 times ●	○	○
Indoor unit piping sensor wire opened	3 times ●	○	—
Indoor unit piping sensor short circuited	3 times ●	○	○
Outdoor unit → Indoor unit communication error	5 times ●	○	—
Indoor unit → Outdoor unit communication error	5 times ●	○	○
Indoor unit fan error	6 times ●	○	—
Outdoor unit heat exchanger temperature sensor error	○	3 times ●	—
Outdoor unit outdoor temperature sensor error	○	4 times ●	—
Outdoor unit discharge temperature sensor error	○	5 times ●	—
Outdoor unit compressor temperature sensor error	○	8 times ●	—
Outdoor unit pressure switch error	○	9 times ●	—
Outdoor unit 2 way valve temperature sensor error	○	—	2 times ●
Outdoor unit 3 way valve temperature sensor error	○	—	3 times ●
Indoor unit fan connection capacity error	○	—	4 times ●
IPM error	○	10 times ●	—
Compressor later location error	○	13 times ●	—
Outdoor fan motor error	○	14 times ●	—

○ : Fast flashing      ● : Slow flashing      — : Off



# DISASSEMBLY ILLUSTRATION

Models : ABH14LBAJ  
ABH18LBAJ  
ABH24LBAJ

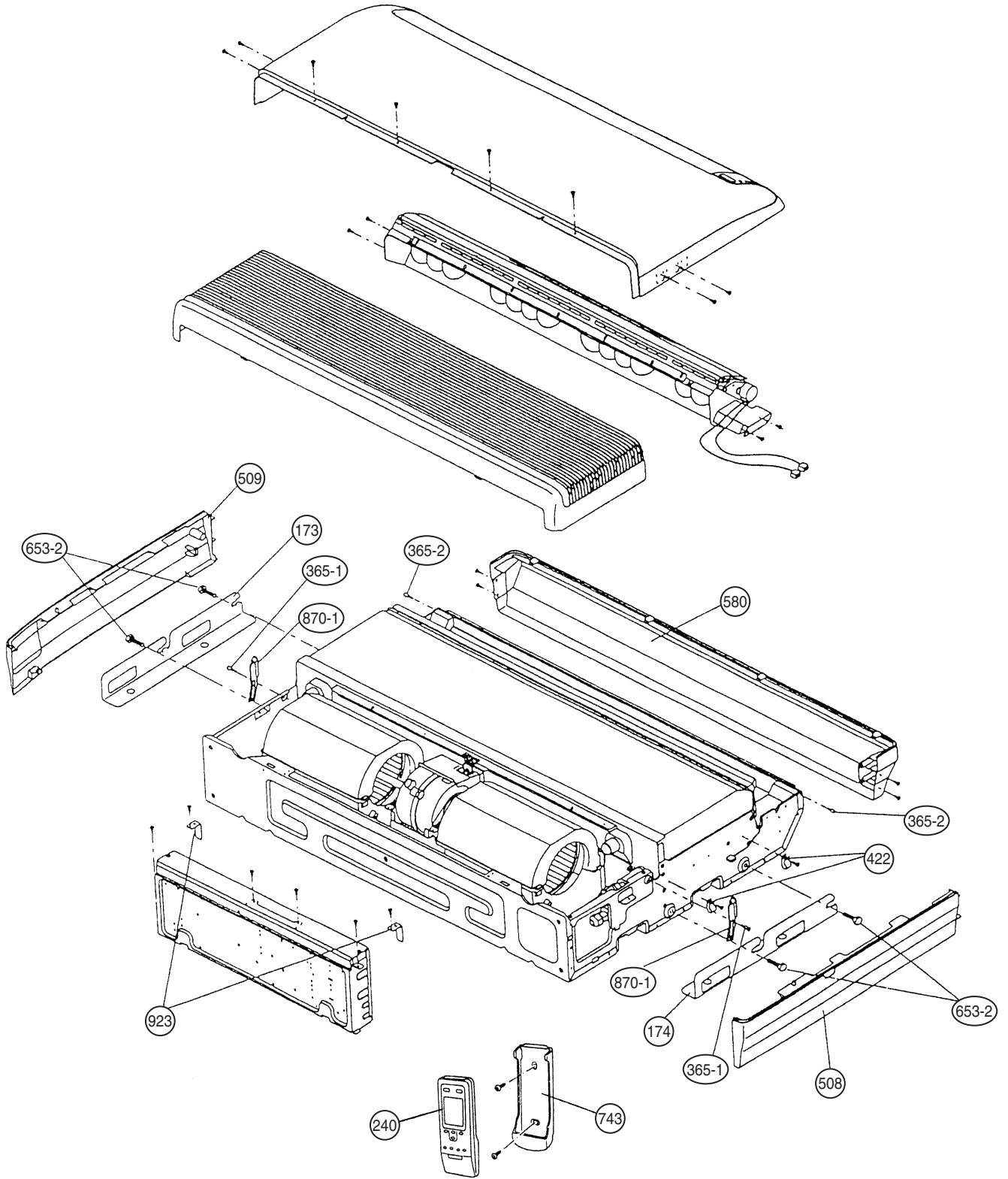

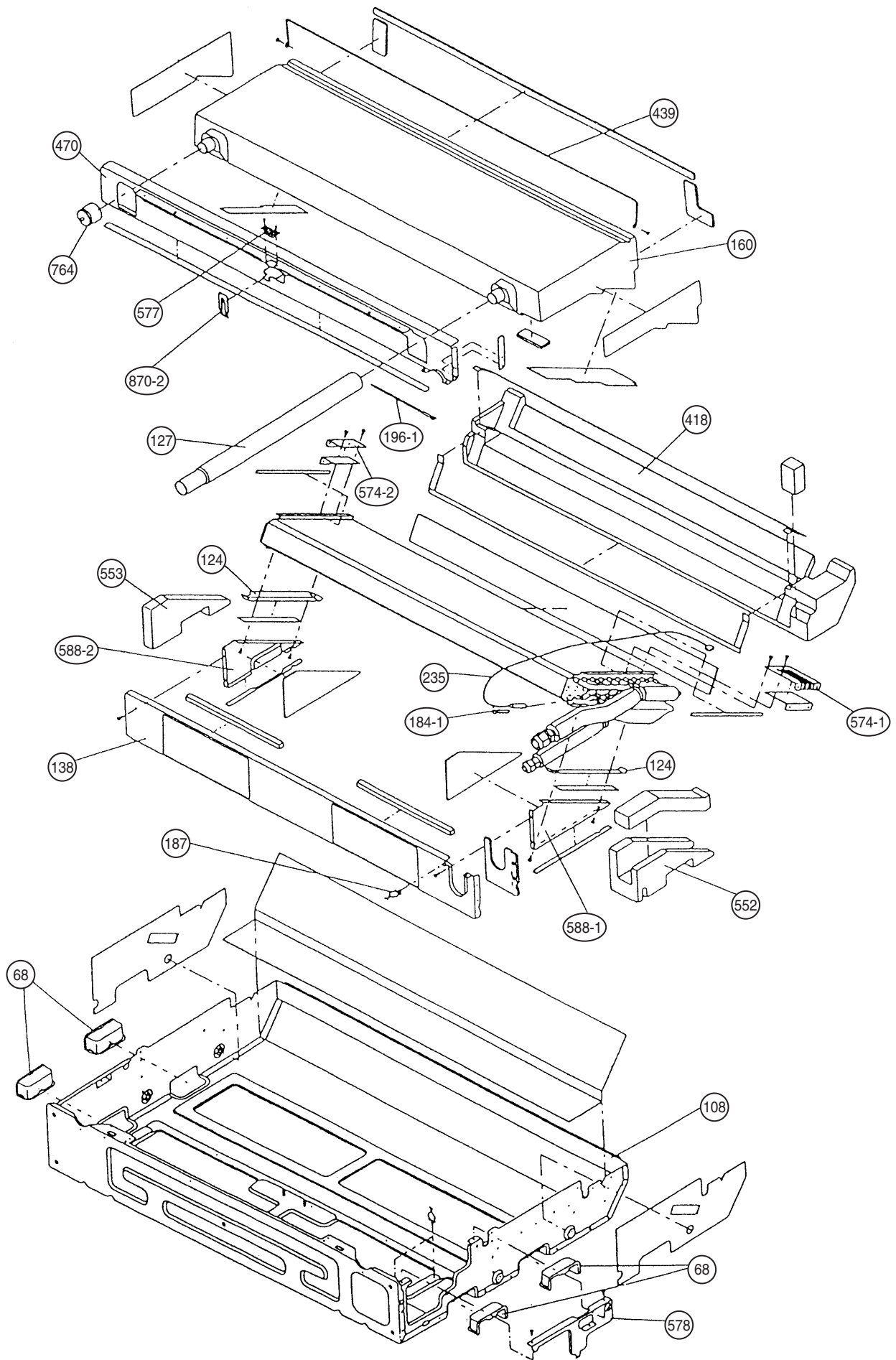

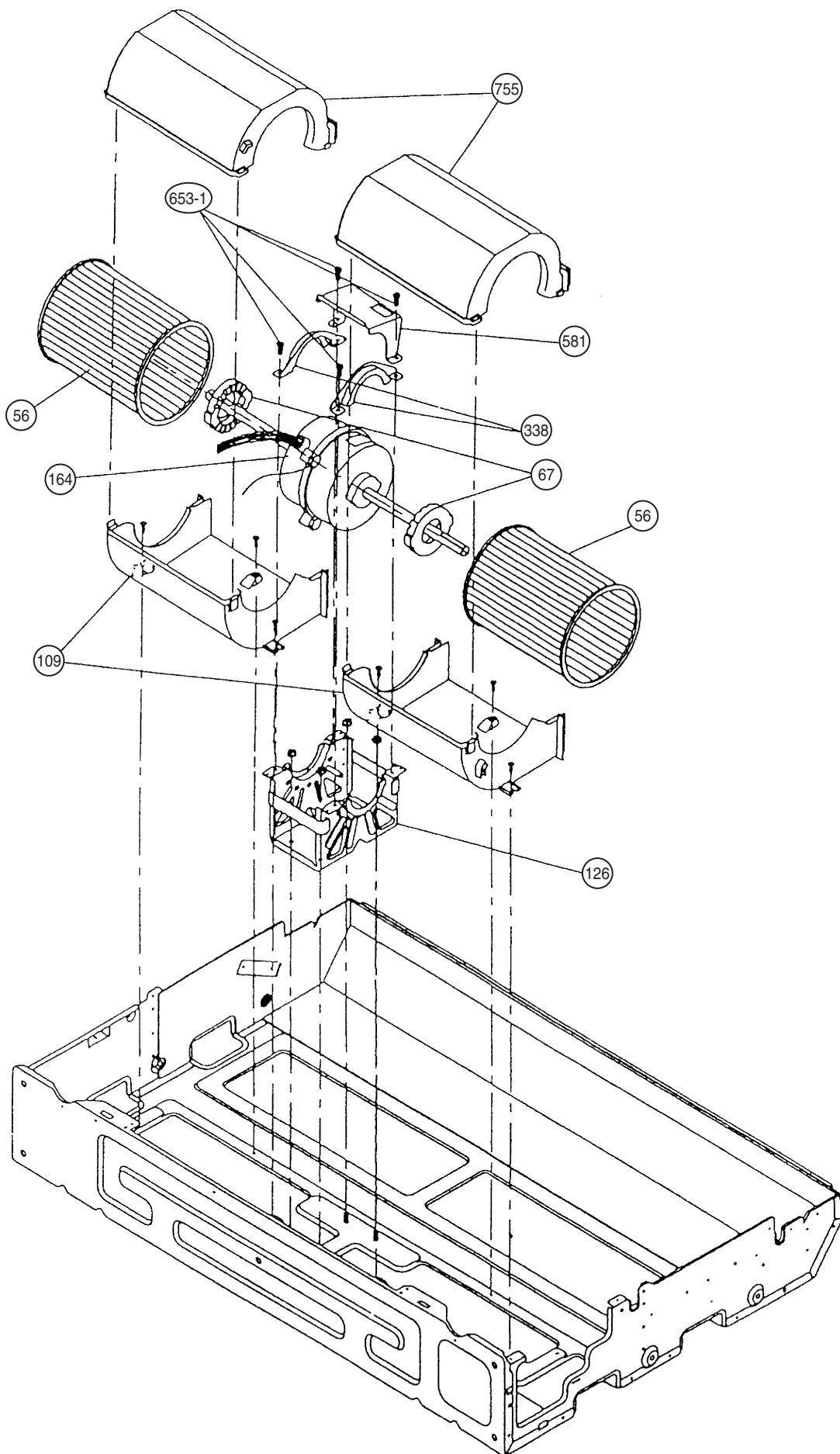



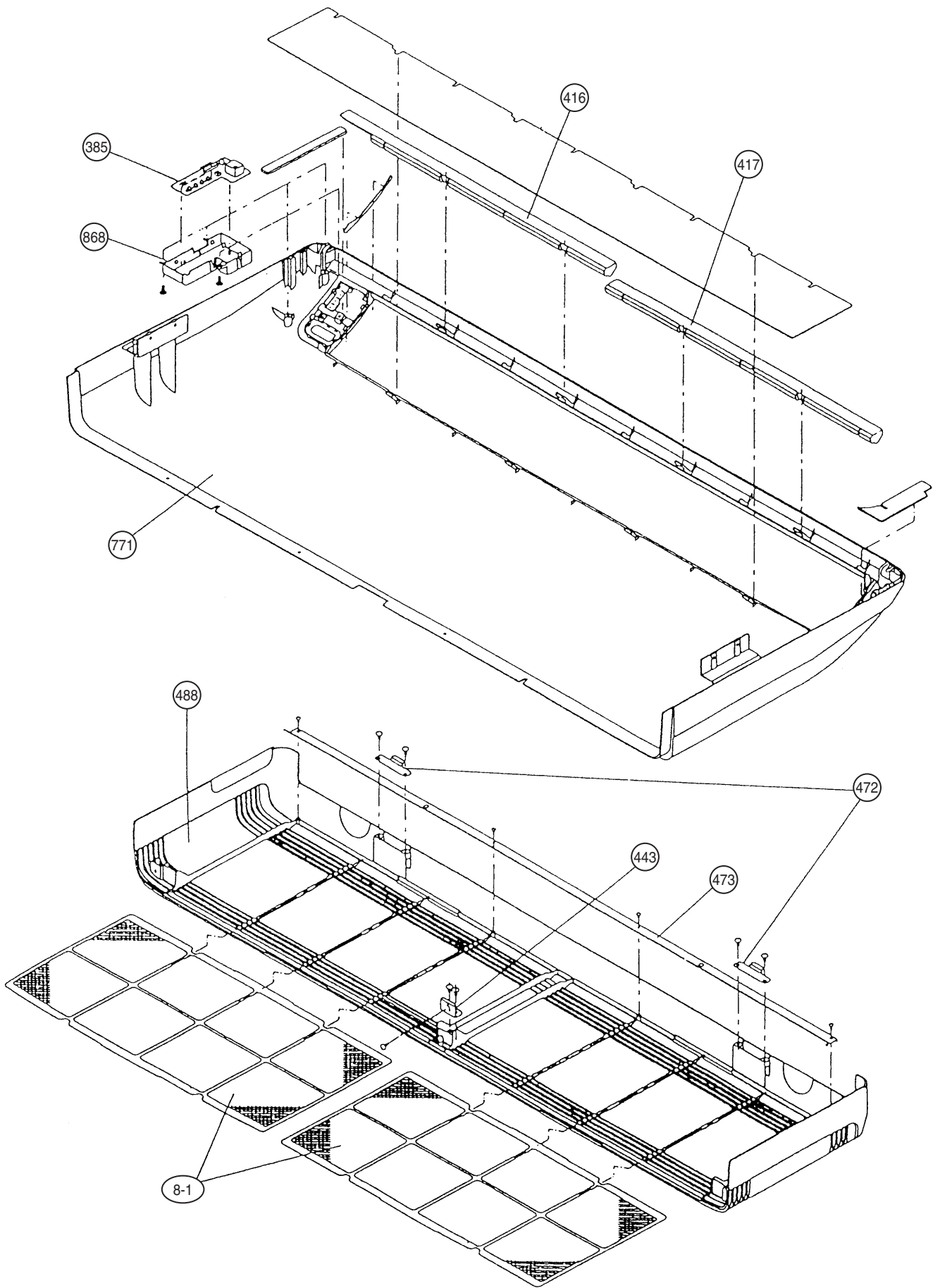

**Model : ABH14LBAJ**

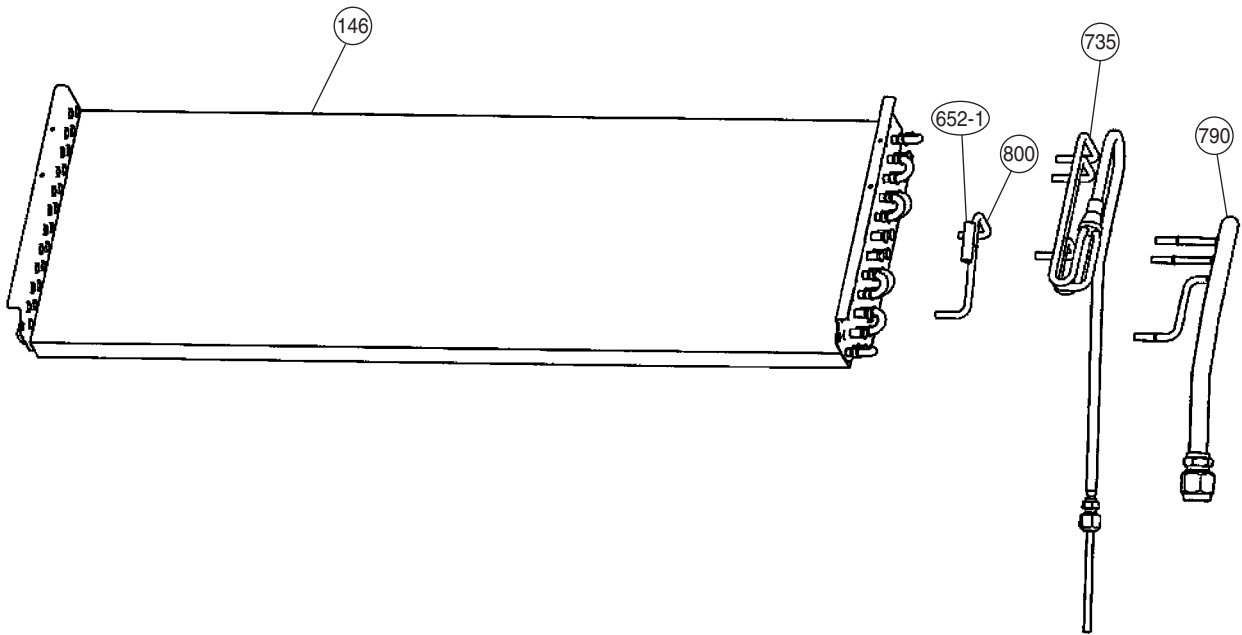

**Models : ABH18LBAJ  
ABH24LBAJ**

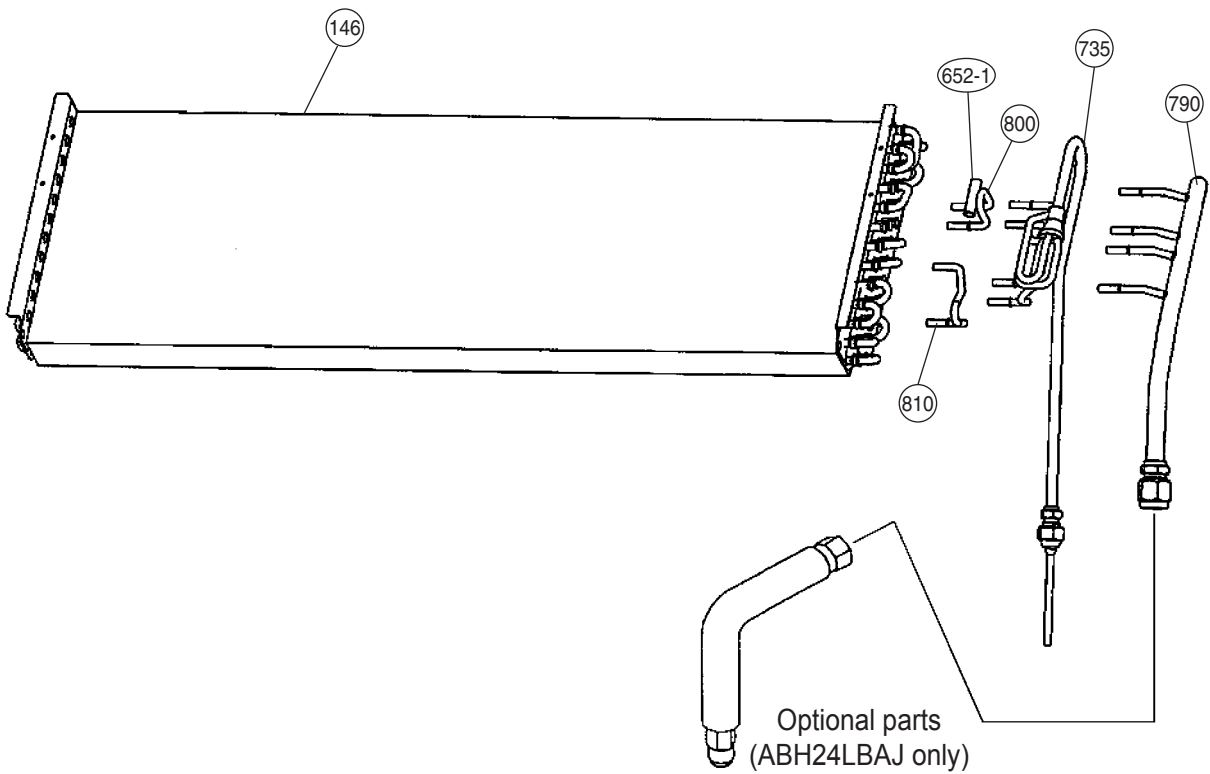

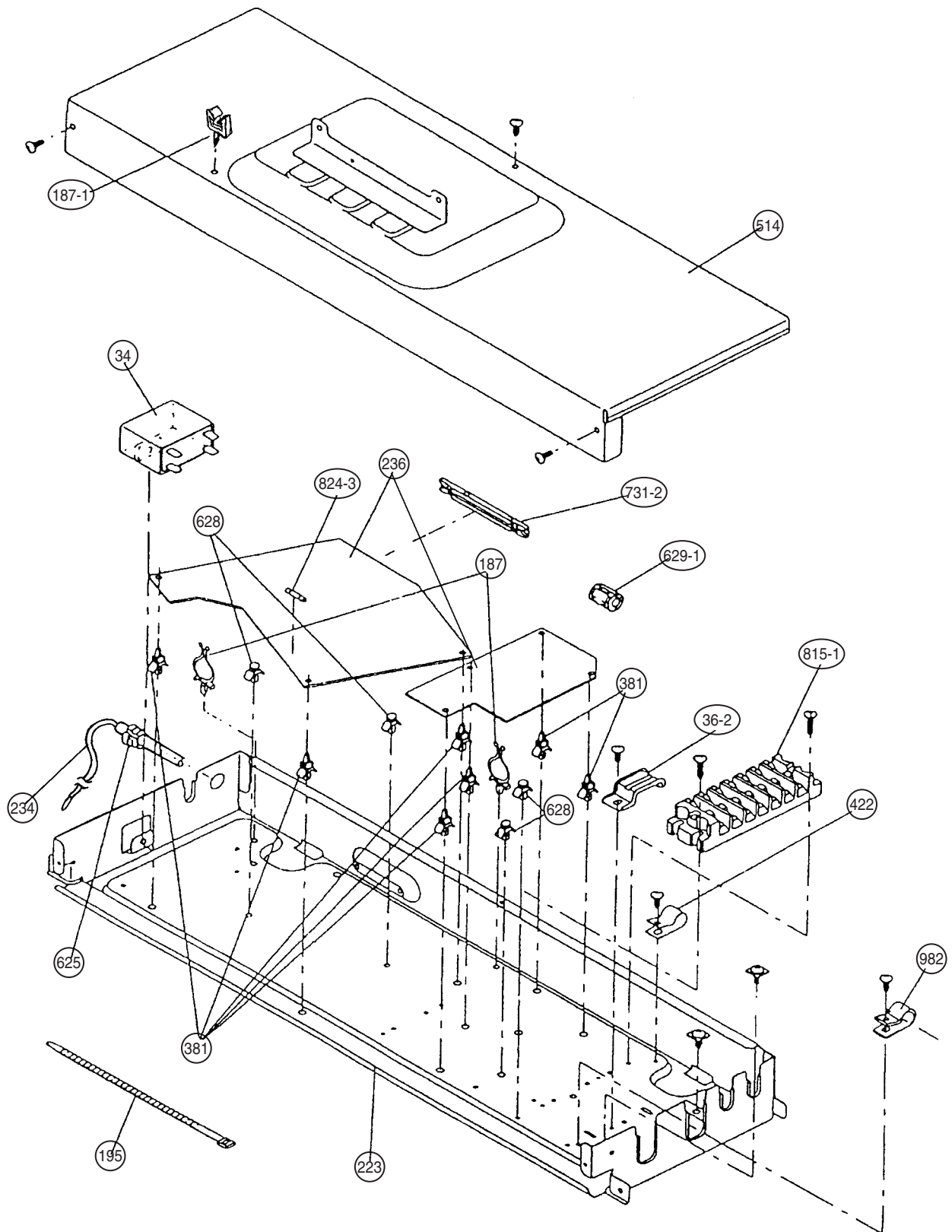



Model : AOH30LMAW4

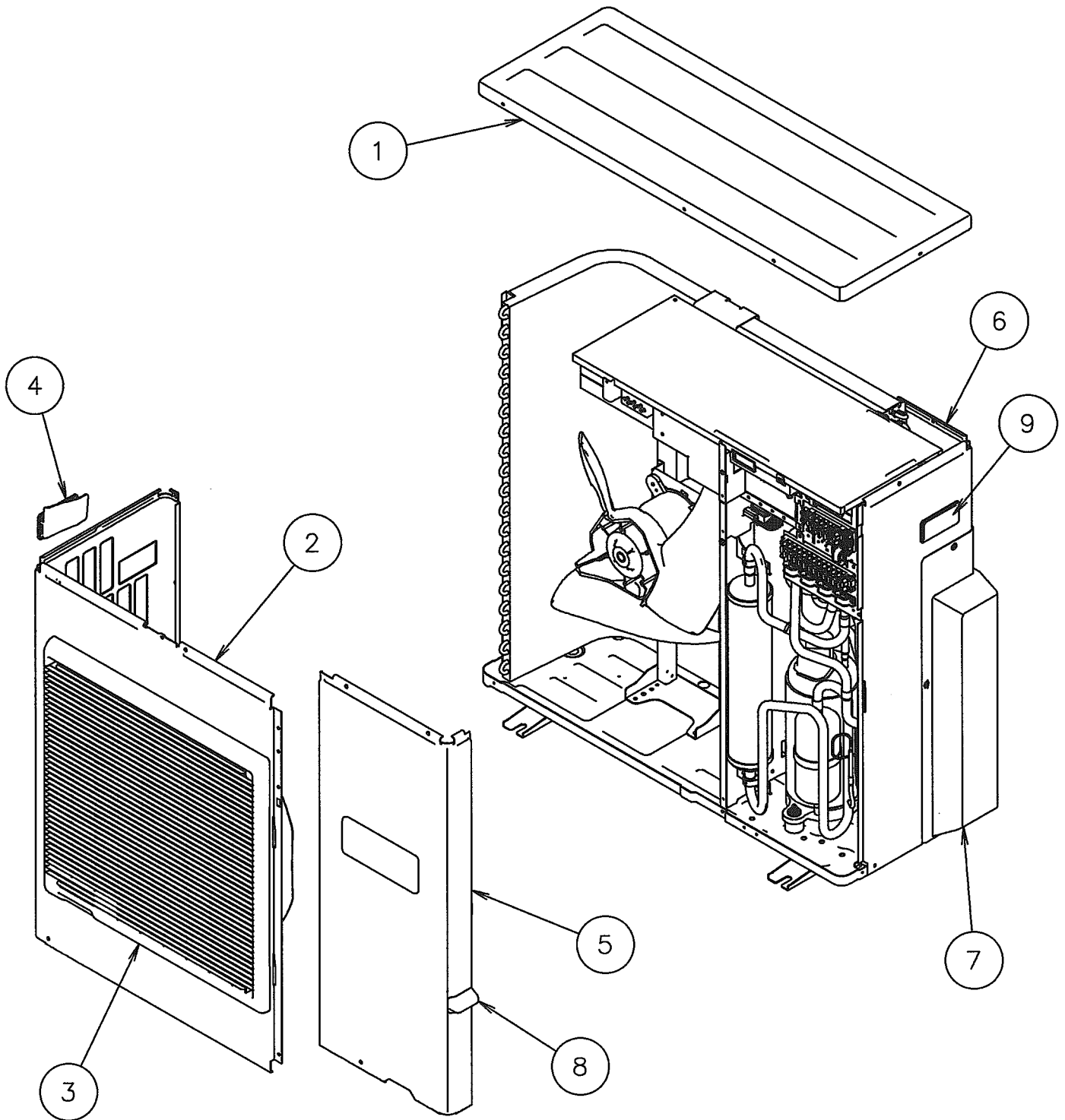

**Model : AOH30LMAW4**

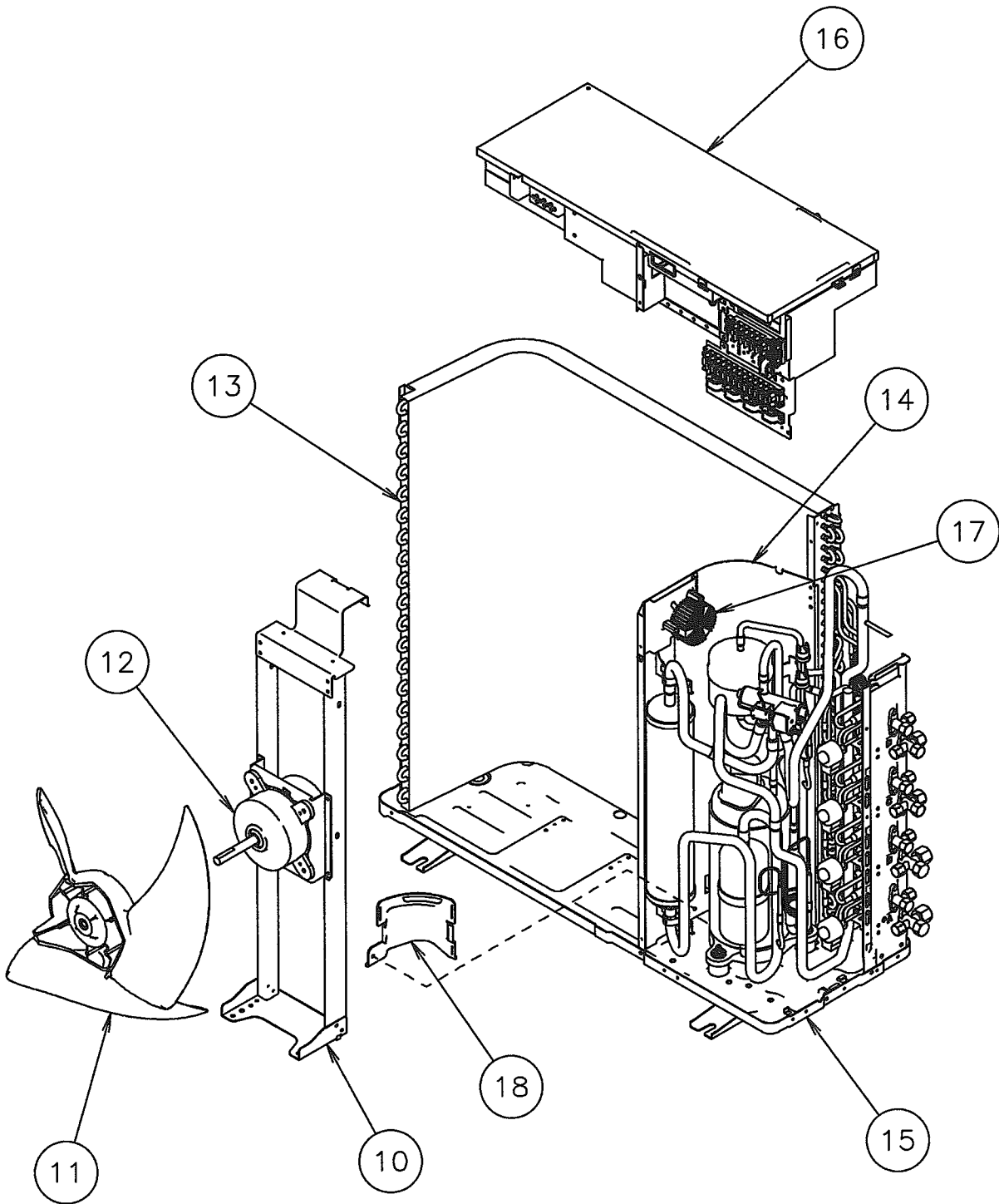

**Model : AOH30LMAW4**

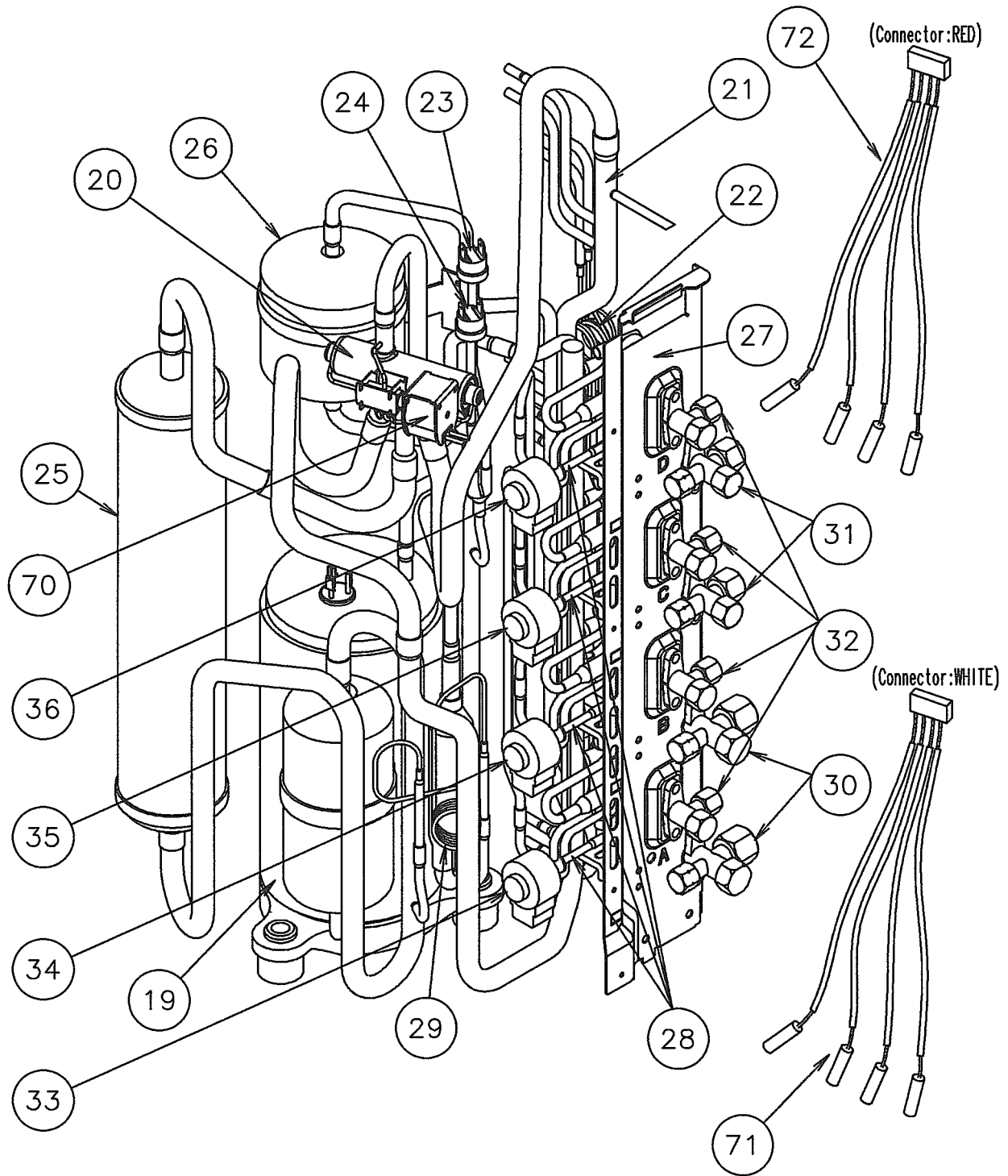

Model : AOH30LMAW4

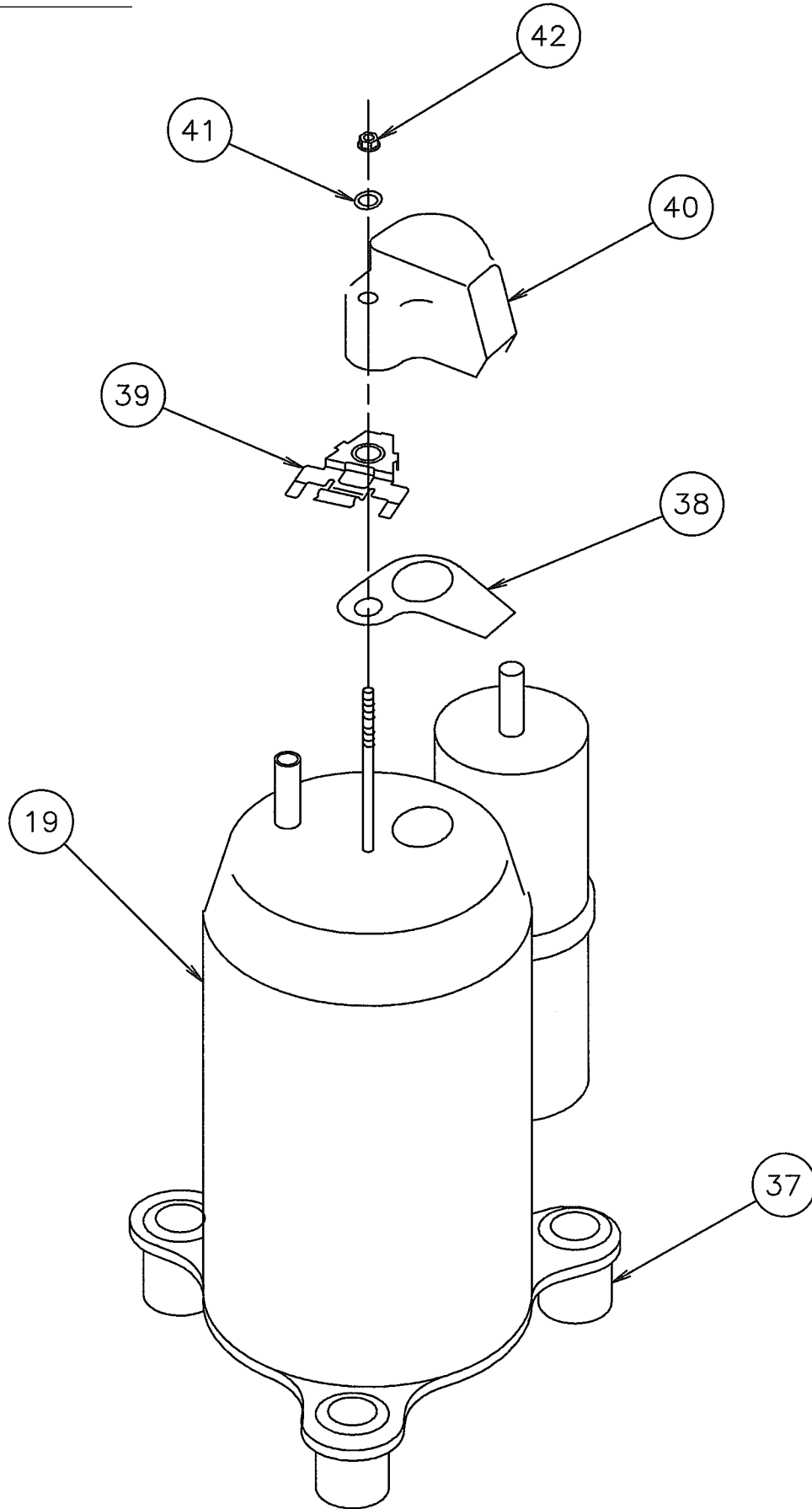



**Model : AOH30LMAW4**

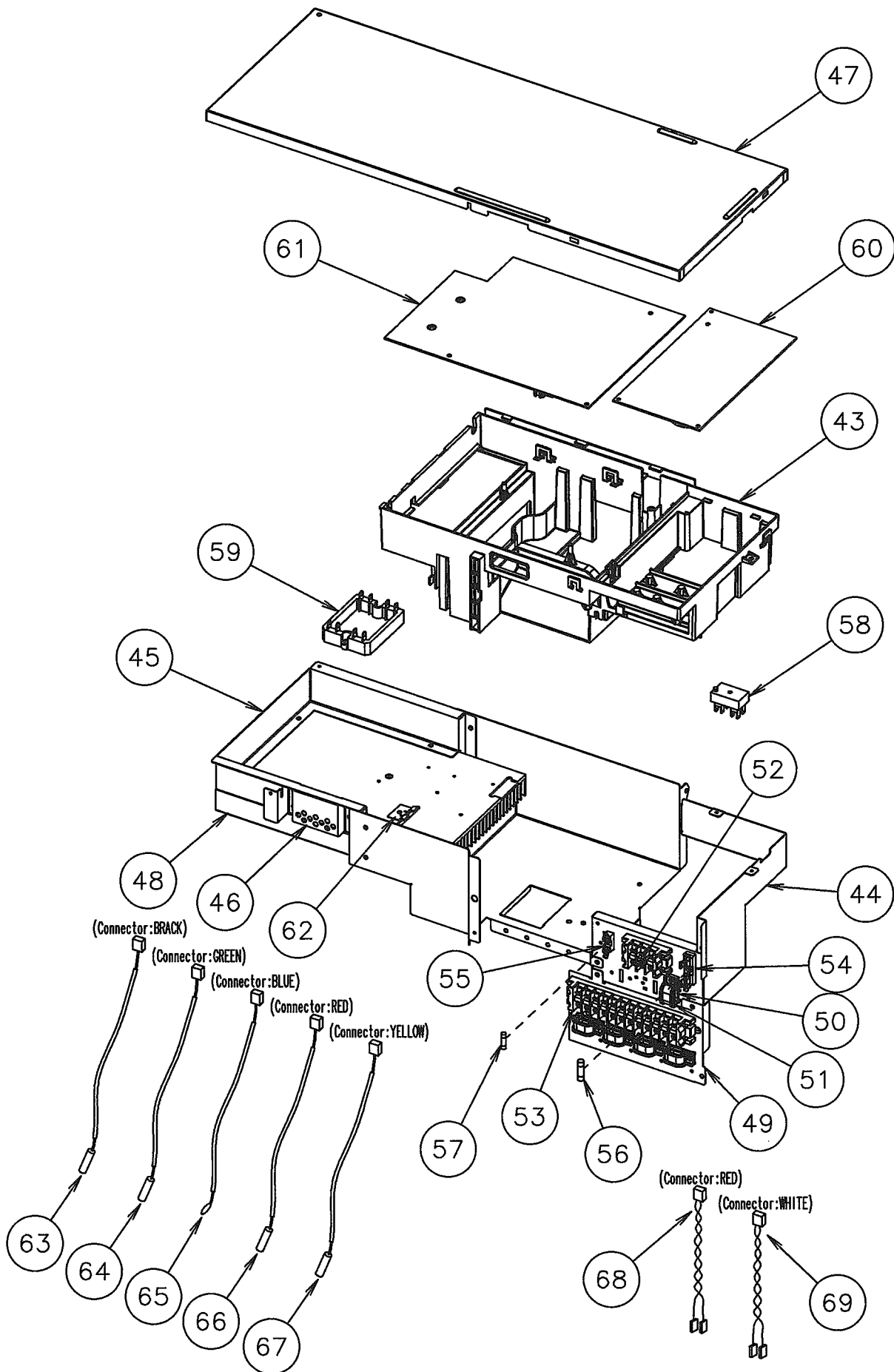

# PARTS LIST

## INDOOR UNIT

Ref. No.	Description	Part No.			Ord.
		ABH14LBAJ	ABH18LBAJ	ABH24LBAJ	Q'ty
8-1	Air Filter	9358567029	9358567029	9358567029	
34	Capacitor (Fan Motor) 1.6µF/400V	9900270018	-----	-----	
34	Capacitor (Fan Motor) 2.3µF/450V	-----	9900270179	9900270179	
36-2	Cord Holder Metal	9356362008	9356362008	9356362008	
56	Sirocco Fan Assy	9385258006	9385258006	9385258006	
67	Rubber (Vibration-proof)	9385102002	9385102002	9385102002	
69	Louver	9358561010	9358561010	9358561010	
68	Cap, Plastic	9358563007	9358563007	9358563007	
108	Base Assy	9359061038	9359061038	9359061038	
109	Casing, Plastic	9358543009	9358543009	9358543009	
124	Dew Proof Plate	9359196006	9359196006	9359196006	
126	Motor Fixing Table Assy	9358591000	9358591000	9358591000	
127	Drain Hose Assy	9359242000	9359242000	9359242000	
138	Separate Wall-A	9358584002	9358584002	9358584002	
146	Evaporator Assy	9362513029	9362513036	9362513036	
160	Drain Pan Assy	9358568002	9358568002	9358568002	
164	Fan Motor Assy-IN	9601527039 (MFA-14JTT)	9601527022 (MFA-18JTT)	9601527015 (MFA-24JTT)	
173	Hanger Bracket-L	9358596005	9358596005	9358596005	
174	Hanger Bracket-R	9358595008	9358595008	9358595008	
184-1	Thermistor Spring-A	313728262708	313728262708	313728262708	
187	Clamp No. 1219	313361271706	313361271706	313361271706	
187-1	Clip (Cable)	9352715006	9352715006	9352715006	
195	Clamp SKB-100	313361275805	313361275805	313361275805	
196-1	Clamp SKB-3M	312300787605	312300787605	312300787605	
223	Control Box	9358600016	9358600016	9358600016	
234	Thermistor Assy-Room	9703299087	9703299087	9703299087	
235	Thermistor Assy-Pipe	9900022020	9900022020	9900022020	
236	Controller PCB Assy	9705914018 (K01AL-0414HSE-C1)	9704557780 (K01AL-040DHSE-C1)	9704557773 (K01AL-0408HSE-C1)	
240	Remote Control Unit AR-JW1	9371190013	9371190013	9371190013	
320	Flap (Upper)-G	9358539019	9358539019	9358539019	
321	Flap (Lower)	9358541012	9358541012	9358541012	
338	Motor Fixture	9358594001	9358594001	9358594001	
361	Bushing	9357942001	9357942001	9357942001	
361-2	Bushing-B, Plastic	9358554005	9358554005	9358554005	
361-3	Bushing-C, Plastic	9358553008	9358553008	9358553008	
365-1	Special Screw	9359092001	9359092001	9359092001	
365-2	Special Screw	9359091004	9359091004	9359091004	
381	Locking Spacer, KGLS-4S	313209391506	313209391506	313209391506	
385	Indicator PCB Assy EZ-0964HSE-D	9701873012	9701873012	9701873012	
407	Motor Rod	9358560006	9358560006	9358560006	
408	Louver Link	9358556009	9358556009	9358556009	
416	Insulation (Panel)-A	9358574003	9358574003	9358574003	
417	Insulation (Panel)-B	9358914007	9358914007	9358914007	
418	Insulation (Flap Base)	9358572009	9358572009	9358572009	
422	Clamp NK-10N	9359183006	9359183006	9359183006	
439	Drain Pan Wire	9358598009	9358598009	9358598009	
443	Arm Bracket	9359281009	9359281009	9359281009	

**INDOOR UNIT (Continued)**

Ref. No.	Description	Part No.			Ord.
		ABH14LBAJ	ABH18LBAJ	ABH24LBAJ	Q'ty
470	Separate Wall-B	9358585009	9358585009	9358585009	
472	Grille Support	9358602003	9358602003	9358602003	
473	Filter Bracket	9358607008	9358607008	9358607008	
488	Grill-F	9358532010	9358532010	9358532010	
500	Protect Cover	9358564004	9358564004	9358564004	
502	Support Stay	9358599006	9358599006	9358599006	
503	Louver Shaft	9358557006	9358557006	9358557006	
505	Louver Stopper	9358555002	9358555002	9358555002	
506	Louver Rod	9358559000	9358559000	9358559000	
508	Cosmetic Panel-R	9358535011	9358535011	9358535011	
509	Cosmetic Panel-L	9358536018	9358536018	9358536018	
514	Control Box Cover	9359097006	9359097006	9359097006	
520	Flap Base	9358537015	9358537015	9358537015	
521	Louver Link Cover	9358558003	9358558003	9358558003	
552	Insulation (Eva.)-R	9358575000	9358575000	9358575000	
553	Insulation (Eva.)-L	9358857007	9358857007	9358857007	
554	Flap Link-Upper (Step Motor-V)	9358551004	9358551004	9358551004	
555	Flap Link-Lower (Step Motor-V)	9358552001	9358552001	9358552001	
558	Motor Rod-A (Step Motor-V)	9358550007	9358550007	9358550007	
574-1	Evaporator Fixture-R (Bracket)	9358589007	9358589007	9358589007	
574-2	Evaporator Fixture-L (Bracket)	9358590003	9358590003	9358590003	
577	Catch TL-119	9359096009	9359096009	9359096009	
578	Base Bracket (Reinforcement Metal)	9358586006	9358586006	9358586006	
580	Top Cover	9358534014	9358534014	9358534014	
581	Protector, Metal (Fan Motor)	9359282006	9359282006	9359282006	
588-1	Evaporator Bracket-R	9358587003	9358587003	9358587003	
588-2	Evaporator Bracket-L	9358588000	9358588000	9358588000	
625	Cord Bushing KR-51	9359240006	9359240006	9359240006	
628	Locking Spacer-B	313005446558	313005446558	313005446558	
629-1	EMI Filter	0400247074	0400247074	0400247074	
652-1	Thermistor Holder Pipe	313806262805	313806262805	313806262805	
653-1	Bolt (Fan Motor Fixing)	0700156014	0700156014	0700156014	
653-2	Bolt	0700190018	0700190018	0700190018	
684	Motor Base	9358562000	9358562000	9358562000	
731-2	Holder (Guide Rail)	0600241018	0600241018	0600241018	
735	Distributor As	9373034018	9373034032	9373034025	
743	Remote Control Unit Holder	9305642014	9305642014	9305642014	
755	Casing Cover	9358544006	9358544006	9358544006	
764	Drain Cap	9358746004	9358746004	9358746004	
771	Panel Assy	9359076131	9359076131	9359076131	
790	Coupring Pipe Assy	-----	9373038153	9373038023	
800	Bypass Pipe Assy	9373032014	9373032021	9373032021	
815-1	Terminal 3P	9900203016	9900203016	9900203016	
824-3	Fuse BET3.15A - 250V	0600222512	0600222512	0600222512	
868	PCB Holder	9358547007	9358547007	9358547007	
870-1	Arm	9358565001	9358565001	9358565001	
870-2	Center Arm	9359280002	9359280002	9359280002	
875	Power Supply PCB Assy	9704561190 (K01AL-0408HSE-PO)	9704561190 (K01AL-0408HSE-PO)	9704561190 (K01AL-0408HSE-PO)	
876-1	Step Motor-H	9359106012	9359106012	9359106012	
876-2	Step Motor-V	9359105015	9359105015	9359105015	
923	Control Box Bracket	9358717004	9358717004	9358717004	
982	Cord Clamp	9357886008	9357886008	9357886008	











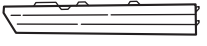

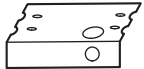
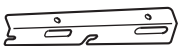
## OUTDOOR UNIT

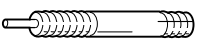
Ref. No.	Description	Part No.	Ord. Q'ty	Ref. No.	Description	Part No.	Ord. Q'ty
		<b>AOH30LMAW4</b>				<b>AOH30LMAW4</b>	
1	Top Panel Sub Assy	9374417025		41	Washer (Rubber)	9358078006	
2	Front Panel M	9374094066		42	Frang Nut	9358079003	
3	Fan Guard	9374330010		43	Inverter Box A	9374603015	
4	Grip Side	9374173013		44	Inverter Box B Assy	9374625017	
5	Service Panel M	9374093069		45	Inverter Box C	9374605019	
6	Right Panel M	9374599028		46	Inverter Box Duct	9374609017	
7	Valve Cover Sub Assy	9374827015		47	Inverter Box Cover	9374608010	
8	Grip Service	9374171019		48	Heat Sink A	9374607013	
9	Grip	9374172016		49	Inverter Box D	9374606016	
10	Motor Bracket Sub Assy	9374418053		50	Clamp (Cord) C	9359677000	
11	Propeller Fan Assy	9366378020		51	Clamp (Cord)	9356857009	
12	Motor. DC Brushless	9601882015		52	Terminal (3P)	9900203016	
13	Condenser A Assy	9374433056		53	Terminal (12P)	9358660164	
14	Separate Wall Assy S	9374629022		54	Fuse Holder (Big)	0501454012	
15	Base Assy	9374166084		55	Fuse Holder (Small)	0501456016	
16	Inverter Assy	9705824010		56	Fuse (Big)	0600086039	
17	Coil. Choke	9703458019		57	Fuse (Small)	0600376116	
18	Cap Foot	9374345014		58	Terminal	9701971015	
19	Compressor Sub Assy	9374423064		59	ACTPM	9703457012	
20	4-Way Valve Assy	9374425044		60	PWB Assy (Power Supply)	9705647039	
21	Inlet Pipe (Cond) A Assy	9373461067		61	PWB Assy (Controller)	9705642058	
22	Outlet Pipe (Cond) A Assy	9374266067		62	Holder (Thermo)	9372797013	
23	Pressure Switch A Assy	9367726028		63	Heat Sink Thermistor	9900311018	
24	Pressure Switch B Assy	9367727025		64	Compressor Temp Thermistor	9900156022	
25	Accumulator Sub Assy	9374426072		65	Thermistor (Outdoor Temp)	9703516078	
26	Receiver Tank Sub Assy	9373426028		66	Heat Exchanger Thermistor	9704220059	
27	Valve Plate A Assy	9374628025		67	Discharg Temp Thermistor	9704219114	
28	Expansion Valve Assy	9370947106		68	Wire (Pressure Sw)(Red)	9367595037	
29	Capillary Assy	9372197370		69	Wire (Pressure Sw)(White)	9367595044	
30	3-Way Valve Assy (1/2")	9372205051		70	Solenoid	9900165055	
31	3-Way Valve Assy (3/8")	9372205044		71	Thermistor (Pipe)(White)	9900322014	
32	2-Way Valve Assy	9372204054		72	Thermistor (Pipe)(Red)	9900289010	
33	Coil (Expansion Valve)(A=Red)	9900057084		---	Emblem Rear	9372171011	
34	Coil (Expansion Valve)(B=White)	9900057053					
35	Coil (Expansion Valve)(C=Green)	9900057060					
36	Coil (Expansion Valve)(D=Blue)	9900057077					
37	Rubber Seat (For Comp)	9358080009					
38	Gasket	9370290004					
39	Holder	9372066010					
40	Terminal Cover (Comp)	9370289008					



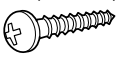
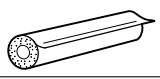
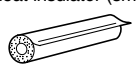

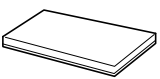
# STANDARD ACCESSORIES

The following installation parts are furnished. Use them as required.

## INDOOR UNIT ACCESSORIES

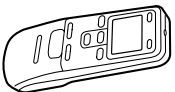
Name and Shape	Q'ty	Application	Part No.
Cosmetic Panel-L 	1		9358536018
Cosmetic Panel-R 	4		9358535011
Tapping screw (φ 4 x 10) 	2		301171164104
Installation template 	1	For positioning the indoor unit. For under ceiling type.	9359107002
Hanger bracket (left) 	1	For suspending the indoor unit from ceiling.	9358596005
Hanger bracket- (right) 	1		9358595008
Anchor bolt (M12) 	4		313806339400
Special nut 	4		
Spring washer 	4		301821112213
Wall bracket 	2	For suspending the indoor unit on the wall.	9358597002
Tapping screw (φ 4 x 20) 	6	For fixing the wall bracket.	301141164200
Coupler heat insulator (large) 	1	For indoor side pipe joint. (Large pipe)	9350716012
Coupler heat insulator (small) 	1	For indoor side pipe joint. (Small pipe)	313209328104
Nylon fastener (small) 	1	For fixing the drain hose.	312300787605
Drain hose 	1		9359242000
Insulation (drain hose) 	1	Adhesive type 70 x 230	9359225003
VT wire 	1	For fixing the drain hose L 280 mm	313806350303

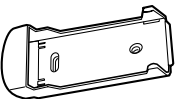
## REMOTE CONTROL UNIT

Name and Shape	Q'ty	Application	Part No.
Remote control unit 	1	Use for air conditioner operation (AR-JW1)	9371190013
Battery (penlight) 	2	For remote control unit	0600185534
Remote control unit holder 	1	For mounting the remote control unit	9305642014
Tapping screw ( $\phi$ 3 x 12) 	2	For remote control unit holder installation	301141533125

## OPTIONAL PARTS FOR INDOOR UNIT

Name and Shape	Q'ty	Application	Part No.
Joint pipe-A 		For indoor side pipe joint (ABH24LBAJ)	9302812021

0504G2832