

Service Manual

SPLIT Pair Wall Mounted Type G-Series



[Applied Models]

- Non-Inverter Pair : Heat Pump

Non Inverter Pair G-Series

●Heat Pump

Indoor Unit

FTYN25GXV1B	FTY25GXV1
FTYN35GXV1B	FTY35GXV1

Outdoor Unit

RYN25GXV1B	RY25GXV1
RYN35GXV1B	RY35GXV1

1. Introduction	V
1.1 Safety Cautions	v
1.2 Used Icons	ix
Part 1 List of Function	1
1. Functions.....	2
Part 2 Specifications	5
1. Specifications	6
Part 3 Printed Circuit Board Connector Wiring Diagram	9
1. Printed Circuit Board Connector Wiring Diagram.....	10
1.1 Indoor Unit.....	10
Part 4 Functions and Control.....	13
1. Functions.....	14
1.1 Power-Airflow Flap, Wide-Angle Louvers and Auto-Swing	14
1.2 Fan Speed Control for Indoor Units.....	15
1.3 Thermostat Control.....	16
1.4 Automatic Operation.....	17
1.5 Programme Dry Function	18
1.6 Sleep Operation	20
1.7 POWERFUL Operation	21
1.8 Other Functions.....	22
2. Function of Thermistor	23
3. Control Specification	24
3.1 Four Way Valve Switching	24
3.2 3-Minute Standby	24
3.3 Compressor Protection Function.....	24
3.4 Freeze-up Protection Control	24
3.5 Heating Peak-cut Control	25
3.6 Defrost Control	26
Part 5 Operation Manual	27
1. System Configuration.....	28
2. Instructions.....	29
2.1 Safety Precautions	29
2.2 Names of Parts.....	31
2.3 Preparation Before Operation	34
2.4 AUTO • DRY • COOL • HEAT • FAN Operation	37
2.5 Adjusting the Airflow Direction.....	39
2.6 POWERFUL Operation	40
2.7 QUIET Operation.....	41
2.8 TIMER Operation	42
2.9 PERSONALIZE Operation	43
2.10 SLEEP Operation.....	44
2.11 Care and Cleaning	45
2.12 Troubleshooting.....	48

Part 6 Service Diagnosis.....	51
1. Caution for Diagnosis.....	52
2. Problem Symptoms and Measures.....	53
3. Service Check Function.....	54
4. Troubleshooting.....	55
4.1 Error Codes and Description.....	55
4.2 Indoor Unit PCB Abnormality.....	56
4.3 Freeze-up Protection Control, High Pressure Control or Indoor Heat Exchanger Thermistor Abnormality.....	57
4.4 Fan Motor or Related Abnormality (AC motor).....	59
4.5 Thermistor or Related Abnormality.....	60
4.6 High Pressure Control in Cooling or Outdoor Heat Exchanger Thermistor Abnormality.....	62
4.7 Hardware Error (Tact Switch Pin Short).....	64
4.8 Insufficient Gas.....	65
5. Check.....	67
5.1 Thermistor Resistance Check.....	67
5.2 Installation Condition Check.....	68
5.3 Outdoor Unit Fan System Check.....	69
5.4 Hall IC Check.....	69
Part 7 Removal Procedure.....	71
1. Indoor Unit.....	72
1.1 Removal of Air Filter.....	72
1.2 Removal of Front Grille.....	75
1.3 Removal of Horizontal Blades / Vertical Blades.....	78
1.4 Removal of Electrical Parts Box / PCB / Swing Motor.....	80
1.5 Removal of Heat Exchanger.....	86
1.6 Install of Drain Plug.....	89
1.7 Removal of Fan Rotor / Fan Motor.....	90
2. Outdoor Unit.....	94
2.1 Removal of Panels.....	94
2.2 Removal of Bellmouth and Left Side Plate.....	96
2.3 Removal of Electrical Device Mounting Plate.....	97
2.4 Removal of Propeller Fan and Fan Motor.....	98
2.5 Removal of Sound Blanket.....	99
2.6 Removal of Partition Plate.....	101
2.7 Removal of Compressor.....	103
Part 8 Others.....	105
1. Others.....	106
1.1 Trial Operation and Testing.....	106
1.2 Pump Down Operation.....	106
1.3 Jumper Settings.....	107
Part 9 Appendix.....	109
1. Piping Diagrams.....	110
1.1 Indoor Units.....	110
1.2 Outdoor Units.....	111

2. Wiring Diagrams.....113
2.1 Indoor Units113
2.2 Outdoor Units113





Index i

Drawings & Flow Charts iii







1. Introduction



1.1 Safety Cautions









Cautions and Warnings

- Be sure to read the following safety cautions before conducting repair work.
- The caution items are classified into “ **Warning**” and “ **Caution**”. The “ **Warning**” items are especially important since they can lead to death or serious injury if they are not followed closely. The “ **Caution**” items can also lead to serious accidents under some conditions if they are not followed. Therefore, be sure to observe all the safety caution items described below.
- About the pictograms
 - △ This symbol indicates the item for which caution must be exercised.
The pictogram shows the item to which attention must be paid.
 - This symbol indicates the prohibited action.
The prohibited item or action is shown in the illustration or near the symbol.
 - This symbol indicates the action that must be taken, or the instruction.
The instruction is shown in the illustration or near the symbol.
- After the repair work is complete, be sure to conduct a test operation to ensure that the equipment operates normally, and explain the cautions for operating the product to the customer.











1.1.1 Cautions Regarding Safety of Workers





 Warning	
<p>Be sure to disconnect the power cable plug from the plug socket before disassembling the equipment for repair. Working on the equipment that is connected to the power supply may cause an electrical shock. If it is necessary to supply power to the equipment to conduct the repair or inspecting the circuits, do not touch any electrically charged sections of the equipment.</p>	
<p>If the refrigerant gas is discharged during the repair work, do not touch the discharged refrigerant gas. The refrigerant gas may cause frostbite.</p>	
<p>When disconnecting the suction or discharge pipe of the compressor at the welded section, evacuate the refrigerant gas completely at a well-ventilated place first. If there is a gas remaining inside the compressor, the refrigerant gas or refrigerating machine oil discharges when the pipe is disconnected, and it may cause injury.</p>	
<p>If the refrigerant gas leaks during the repair work, ventilate the area. The refrigerant gas may generate toxic gases when it contacts flames.</p>	
<p>The step-up capacitor supplies high-voltage electricity to the electrical components of the outdoor unit. Be sure to discharge the capacitor completely before conducting repair work. A charged capacitor may cause an electrical shock.</p>	
<p>Do not start or stop the air conditioner operation by plugging or unplugging the power cable plug. Plugging or unplugging the power cable plug to operate the equipment may cause an electrical shock or fire.</p>	







 Warning	
Be sure to wear a safety helmet, gloves, and a safety belt when working at a high place (more than 2m). Insufficient safety measures may cause a fall accident.	
In case of R410A refrigerant models, be sure to use pipes, flare nuts and tools for the exclusive use of the R410A refrigerant. The use of materials for R22 refrigerant models may cause a serious accident such as a damage of refrigerant cycle as well as an equipment failure.	





 Caution	
Do not repair the electrical components with wet hands. Working on the equipment with wet hands may cause an electrical shock.	
Do not clean the air conditioner by splashing water. Washing the unit with water may cause an electrical shock.	
Be sure to provide the grounding when repairing the equipment in a humid or wet place, to avoid electrical shocks.	
Be sure to turn off the power switch and unplug the power cable when cleaning the equipment. The internal fan rotates at a high speed, and cause injury.	
Be sure to conduct repair work with appropriate tools. The use of inappropriate tools may cause injury.	
Be sure to check that the refrigerating cycle section has cooled down enough before conducting repair work. Working on the unit when the refrigerating cycle section is hot may cause burns.	
Use the welder in a well-ventilated place. Using the welder in an enclosed room may cause oxygen deficiency.	

1.1.2 Cautions Regarding Safety of Users

 Warning	
Be sure to use parts listed in the service parts list of the applicable model and appropriate tools to conduct repair work. Never attempt to modify the equipment. The use of inappropriate parts or tools may cause an electrical shock, excessive heat generation or fire.	
If the power cable and lead wires have scratches or deteriorated, be sure to replace them. Damaged cable and wires may cause an electrical shock, excessive heat generation or fire.	
Do not use a joined power cable or extension cable, or share the same power outlet with other electrical appliances, since it may cause an electrical shock, excessive heat generation or fire.	
Be sure to use an exclusive power circuit for the equipment, and follow the local technical standards related to the electrical equipment, the internal wiring regulations, and the instruction manual for installation when conducting electrical work. Insufficient power circuit capacity and improper electrical work may cause an electrical shock or fire.	
Be sure to use the specified cable for wiring between the indoor and outdoor units. Make the connections securely and route the cable properly so that there is no force pulling the cable at the connection terminals. Improper connections may cause excessive heat generation or fire.	
When wiring between the indoor and outdoor units, make sure that the terminal cover does not lift off or dismount because of the cable. If the cover is not mounted properly, the terminal connection section may cause an electrical shock, excessive heat generation or fire.	
Do not damage or modify the power cable. Damaged or modified power cable may cause an electrical shock or fire. Placing heavy items on the power cable, and heating or pulling the power cable may damage the cable.	
Do not mix air or gas other than the specified refrigerant (R410A / R22) in the refrigerant system. If air enters the refrigerating system, an excessively high pressure results, causing equipment damage and injury.	
If the refrigerant gas leaks, be sure to locate the leaking point and repair it before charging the refrigerant. After charging refrigerant, make sure that there is no refrigerant leak. If the leaking point cannot be located and the repair work must be stopped, be sure to perform pump-down and close the service valve, to prevent the refrigerant gas from leaking into the room. The refrigerant gas itself is harmless, but it may generate toxic gases when it contacts flames, such as fan and other heaters, stoves and ranges.	
When relocating the equipment, make sure that the new installation site has sufficient strength to withstand the weight of the equipment. If the installation site does not have sufficient strength and if the installation work is not conducted securely, the equipment may fall and cause injury.	





 Warning	
Check to make sure that the power cable plug is not dirty or loose, then insert the plug into a power outlet securely. If the plug has dust or loose connection, it may cause an electrical shock or fire.	
Be sure to install the product correctly by using the provided standard installation frame. Incorrect use of the installation frame and improper installation may cause the equipment to fall, resulting in injury.	For unitary type only 
Be sure to install the product securely in the installation frame mounted on the window frame. If the unit is not securely mounted, it may fall and cause injury.	For unitary type only 
When replacing the coin battery in the remote controller, be sure to disposed of the old battery to prevent children from swallowing it. If a child swallows the coin battery, see a doctor immediately.	

 Caution	
Installation of a leakage breaker is necessary in some cases depending on the conditions of the installation site, to prevent electrical shocks.	
Do not install the equipment in a place where there is a possibility of combustible gas leaks. If the combustible gas leaks and remains around the unit, it may cause a fire.	
Check to see if the parts and wires are mounted and connected properly, and if the connections at the soldered or crimped terminals are secure. Improper installation and connections may cause excessive heat generation, fire or an electrical shock.	
If the installation platform or frame has corroded, replace it. Corroded installation platform or frame may cause the unit to fall, resulting in injury.	
Check the grounding, and repair it if the equipment is not properly grounded. Improper grounding may cause an electrical shock.	

 Caution	
Be sure to measure the insulation resistance after the repair, and make sure that the resistance is 1 MΩ or higher. Faulty insulation may cause an electrical shock.	
Be sure to check the drainage of the indoor unit after the repair. Faulty drainage may cause the water to enter the room and wet the furniture and floor.	
Do not tilt the unit when removing it. The water inside the unit may spill and wet the furniture and floor.	
Be sure to install the packing and seal on the installation frame properly. If the packing and seal are not installed properly, water may enter the room and wet the furniture and floor.	For unitary type only 

1.2 Used Icons

Icons are used to attract the attention of the reader to specific information. The meaning of each icon is described in the table below:

Icon	Type of Information	Description
 Note:	Note	A “note” provides information that is not indispensable, but may nevertheless be valuable to the reader, such as tips and tricks.
 Caution	Caution	A “caution” is used when there is danger that the reader, through incorrect manipulation, may damage equipment, lose data, get an unexpected result or has to restart (part of) a procedure.
 Warning	Warning	A “warning” is used when there is danger of personal injury.
	Reference	A “reference” guides the reader to other places in this binder or in this manual, where he/she will find additional information on a specific topic.

Part 1

List of Function

1. Functions.....2

1. Functions

Category	Functions	FTYN25-35GXV1B RYN25-35GXV1B	Category	Functions	FTYN25-35GXV1B RYN25-35GXV1B	
Basic Function	Inverter (with Inverter Power Control)	—	Health & Clean	Air Purifying Filter	○	
	Operation Limit for Cooling (°CDB)	10 ~46		Photocatalytic Deodorizing Filter	—	
	Operation Limit for Heating (°CWB)	-10 ~15		Air Purifying Filter with Photocatalytic Deodorizing Function	—	
	PAM Control	—		Titanium Apatite Photocatalytic Air-Purifying Filter	—	
Compressor	Oval Scroll Compressor	—	Health & Clean	Longlife Filter	—	
	Swing Compressor	—		Air Filter	○	
	Rotary Compressor	○		Wipe-clean Flat Panel	○	
	Reluctance DC Motor	—		Washable Grille	—	
Comfortable Airflow	Power-Airflow Flap	○	Health & Clean	Mold Proof Operation	—	
	Power-Airflow Dual Flaps	—		Heating Dry Operation	—	
	Power-Airflow Diffuser	—		Good-Sleep Cooling Operation	—	
	Wide-Angle Louvers	○		Sleep Operation	○	
	Vertical Auto-Swing (Up and Down)	○		Personalize Operation	○	
	Horizontal Auto-Swing (Right and Left)	—		Timer	Count up-down Timer	○
	3-D Airflow	—			24-Hour ON/OFF Timer	○
	Comfort Airflow Mode	—			Night Set Mode	○
3-Step Airflow (H/P Only)	—	Worry Free "Reliability & Durability"	Auto-Restart (after Power Failure)		○	
Comfort Control	Auto Fan Speed		○	Self-Diagnosis (Digital, LED) Display	○	
	Indoor Unit Quiet Operation		○	Wiring Error Check	—	
	Night Quiet Mode (Automatic)		—	Anticorrosion Treatment of Outdoor Heat Exchanger	○	
	Outdoor Unit Quiet Operation (Manual)	—	Hydrophilic Treatment of Outdoor Heat Exchanger	○		
Comfort Control	INTELLIGENT EYE	—	Flexibility	Multi-Split / Split Type Compatible Indoor Unit	—	
	Quick Warming Function	○		Flexible Voltage Correspondence	—	
	Hot-Start Function	○		High Ceiling Application	—	
	Automatic Defrosting	○		Chargeless	10m	
Operation	Automatic Operation	○	Flexibility	Either Side Drain (Right or Left)	○	
	Programme Dry Function	○		Power Selection	—	
	Fan Only	○		Remote Control	5-Rooms Centralized Controller (Option)	—
Lifestyle Convenience	New POWERFUL Operation (Non-Inverter)	○	Remote Control Adaptor (Normal Open-Pulse Contact) (Option)		—	
	Inverter POWERFUL Operation	—	Remote Control Adaptor (Normal Open Contact) (Option)		—	
	Priority-Room Setting	—	DIIII-NET Compatible (Adaptor) (Option)		—	
	Cooling / Heating Mode Lock	—	Remote Controller		Wireless	○
	HOME LEAVE Operation	—			Wired	—
	ECONO Mode	—				
	Indoor Unit On/Off Switch	○				
	Signal Reception Indicator	○				
Temperature Display	—					
Another Room Operation	—					

Note: ○ : Holding Functions
— : No Functions

Category	Functions	FTY25-35GXV1 RY25-35GXV1	Category	Functions	FTY25-35GXV1 RY25-35GXV1	
Basic Function	Inverter (with Inverter Power Control)	—	Health & Clean	Air Purifying Filter	○	
	Operation Limit for Cooling (°CDB)	10 ~46		Photocatalytic Deodorizing Filter	—	
	Operation Limit for Heating (°CWB)	-10 ~24		Air Purifying Filter with Photocatalytic Deodorizing Function	—	
	PAM Control	—		Titanium Apatite Photocatalytic Air-Purifying Filter	—	
Compressor	Oval Scroll Compressor	—		Longlife Filter	—	
	Swing Compressor	—		Air Filter	○	
	Rotary Compressor	○		Wipe-clean Flat Panel	○	
	Reluctance DC Motor	—		Washable Grille	—	
Comfortable Airflow	Power-Airflow Flap	○		Mold Proof Operation	—	
	Power-Airflow Dual Flaps	—		Heating Dry Operation	—	
	Power-Airflow Diffuser	—		Good-Sleep Cooling Operation	—	
	Wide-Angle Louvers	○		Sleep Operation	○	
	Vertical Auto-Swing (Up and Down)	○		Personalize Operation	○	
	Horizontal Auto-Swing (Right and Left)	—		Timer	Count Up-down Timer	○
	3-D Airflow	—			24-Hour ON/OFF Timer	○
	Comfort Airflow Mode	—			Night Set Mode	○
	3-Step Airflow (H/P Only)	—	Worry Free "Reliability & Durability"	Auto-Restart (after Power Failure)	○	
Comfort Control	Auto Fan Speed	○		Self-Diagnosis (Digital, LED) Display	○	
	Indoor Unit Quiet Operation	○		Wiring Error Check	—	
Night Quiet Mode (Automatic)	—	Anticorrosion Treatment of Outdoor Heat Exchanger		○		
Outdoor Unit Quiet Operation (Manual)	—	Hydrophilic Treatment of Outdoor Heat Exchanger		○		
INTELLIGENT EYE	—	Flexibility		Multi-Split / Split Type Compatible Indoor Unit	—	
Quick Warming Function	○			Flexible Voltage Correspondence	—	
Hot-Start Function	○		High Ceiling Application	—		
Automatic Defrosting	○		Chargeless	10m		
Operation	Automatic Operation		○	Either Side Drain (Right or Left)	○	
	Programme Dry Function	○	Power Selection	—		
	Fan Only	○	Remote Control	5-Rooms Centralized Controller (Option)	—	
Lifestyle Convenience	New POWERFUL Operation (Non-Inverter)	○		Remote Control Adaptor (Normal Open-Pulse Contact) (Option)	—	
	Inverter POWERFUL Operation	—		Remote Control Adaptor (Normal Open Contact) (Option)	—	
	Priority-Room Setting	—		DIII-NET Compatible (Adaptor) (Option)	—	
	Cooling / Heating Mode Lock	—		Remote Controller	Wireless	○
	HOME LEAVE Operation	—			Wired	—
	ECONO Mode	—				
	Indoor Unit On/Off Switch	○				
	Signal Reception Indicator	○				
Temperature Display	—					
Another Room Operation	—					

Note: ○ : Holding Functions
— : No Functions

Part 2 Specifications

1. Specifications6

1. Specifications

50Hz 230V

Models	Indoor Units		FTYN25GXV1B		FTYN35GXV1B	
	Outdoor Units		RYN25GXV1B		RYN35GXV1B	
			Cooling	Heating	Cooling	Heating
Capacity Rated (Min.~Max.)	kW		2.5	2.85	3.27	3.68
	Btu/h		8,500	9,700	11,200	12,600
	kcal/h		2,150	2,450	2,810	3,160
Running Current (Rated)	A		3.4	3.5	3.4	3.5
Power Consumption Rated (Min.~Max.)	W		770	780	770	780
Power Factor	%		98.5	98.6	93.4	92.4
COP (Rated)	W/W		3.25	3.65	3.21	3.61
Piping Connections	Liquid	mm	φ 6.4		φ 6.4	
	Gas	mm	φ 9.5		φ 12.7	
	Drain	mm	φ 18.0		φ 18.0	
Heat Insulation			Both Liquid and Gas Pipes		Both Liquid and Gas Pipes	
Max. Interunit Piping Length	m		15		15	
Max. Interunit Height Difference	m		10		10	
Chargeless	m		10		10	
Amount of Additional Charge of Refrigerant	g/m		20		20	
Indoor Units			FTYN25GXV1B		FTYN35GXV1B	
Front Panel Color			White		White	
Airflow Rate	m³/min (cfm)	H	9.5 (335)	9.7 (342)	9.8 (346)	10.5 (371)
		M	7.9 (279)	8.1 (286)	8.3 (293)	8.8 (311)
		L	6.3 (222)	6.6 (233)	6.8 (240)	7.1 (251)
		SL	5.9 (208)	6.2 (219)	6.4 (226)	6.7 (237)
Fan	Type	Cross Flow Fan		Cross Flow Fan		
	Motor Output	W	18		18	
	Speed	Steps	3 Steps, Quiet, Auto		3 Steps, Quiet, Auto	
Air Direction Control			Right, Left, Horizontal, Downward		Right, Left, Horizontal, Downward	
Air Filter			Removable / Washable / Mildew Proof		Removable / Washable / Mildew Proof	
Running Current (Rated)	A		0.2	0.2	0.2	0.2
Power Consumption (Rated)	W		37	37	37	38
Power Factor	%		79.7	79.7	80.4	82.6
Temperature Control			Microcomputer Control		Microcomputer Control	
Dimensions (HxWxD)	mm		288x800x204		288x800x204	
Packaged Dimensions (HxWxD)	mm		288x874x360		288x874x360	
Weight	kg		9		9	
Gross Weight	kg		13		13	
Operation Sound	H/M/L/SL	dBA	38 / 32 / 27 / 25	38 / 32 / 27 / 25	38 / 34 / 29 / 27	40 / 35 / 29 / 27
Outdoor Units			RYN25GXV1B		RYN35GXV1B	
Casing Color			White		White	
Compressor	Type	Hermetic Motor Compressor		Hermetic Motor Compressor		
	Model	5PS102DAK01		5PS132DBB01		
Refrigerant Oil	Motor Output	W	799		900	
	Type	RB68A / FREOL ALPHA68M		RB68A / FREOL ALPHA68M		
Refrigerant	Charge	L	0.35		0.35	
	Type	R-410A		R-410A		
Refrigerant	Charge	kg	0.80		1.10	
	Type	R-410A		R-410A		
Airflow Rate	m³/min		34.9	31.6	31.4	28.1
	cfm		1,232	1,116	1,108	991
Fan	Type	Propeller		Propeller		
	Motor Output	W	26		26	
Running Current (Rated)	A		3.2	3.3	4.6	4.6
Power Consumption (Rated)	W		733	743	983	982
Power Factor	%		99.6	97.9	92.9	92.8
Starting Current	A		17.0		23.5	
Dimensions (HxWxD)	mm		550x765x285		550x765x285	
Packaged Dimensions (HxWxD)	mm		358x611x899		358x611x899	
Weight	kg		31		34	
Gross Weight	kg		35		38	
Operation Sound	H	dBA	48	49	48	49
Drawing No.			3D060315		3D060316	

Note: ■ The data are based on the conditions shown in the table below.

Cooling	Heating	Piping Length
Indoor ; 27°CDB/19°CWB Outdoor ; 35°CDB/24°CWB	Indoor ; 20°CDB Outdoor ; 7°CDB/6°CWB	5m

Conversion Formulae
kcal/h=kWx860 Btu/h=kWx3414 cfm=m³/minx35.3

50Hz 220V

Models	Indoor Units		FTY25GXV1		FTYN35GXV1	
	Outdoor Units		RY25GXV1		RYN35GXV1	
			Cooling	Heating	Cooling	Heating
Capacity	kW		2.65	2.91	3.4	3.8
	Btu/h		9,000	9,900	11,600	13,000
	kcal/h		2,300	2,500	2,900	3,300
Running Current	A		4.1	3.7	5.0	5.2
Power Consumption	W		880	800	1,060	1,100
Power Factor	%		98.1	98.0	96.9	96.7
COP	W/W		3.01	3.64	3.21	3.45
Piping Connections	Liquid	mm	φ 6.4		φ 6.4	
	Gas	mm	φ 9.5		φ 12.7	
	Drain	mm	φ18.0		φ18.0	
Heat Insulation		Both Liquid and Gas Pipes		Both Liquid and Gas Pipes		
Max. Interunit Piping Length	m		15		15	
Max. Interunit Height Difference	m		10		10	
Chargeless	m		10		10	
Amount of Additional Charge of Refrigerant	g/m		20		20	
Indoor Units			FTY25GXV1		FTYN35GXV1	
Front Panel Color			White		White	
Airflow Rate	m³/min (cfm)	H	9.5 (335)	9.7 (342)	9.8 (346)	10.5 (371)
		M	7.9 (279)	8.1 (286)	8.3 (293)	8.8 (311)
		L	6.3 (222)	6.6 (233)	6.8 (240)	7.1 (251)
		SL	5.9 (208)	6.2 (219)	6.4 (226)	6.7 (237)
Fan	Type		Cross Flow Fan		Cross Flow Fan	
	Motor Output	W	18		18	
	Speed	Steps	3 Steps, Quiet, Auto		3 Steps, Quiet, Auto	
Air Direction Control			Right, Left, Horizontal, Downward		Right, Left, Horizontal, Downward	
Air Filter			Removable / Washable / Mildew Proof		Removable / Washable / Mildew Proof	
Running Current	A		0.2	0.2	0.2	0.2
Power Consumption	W		37	37	37	38
Power Factor	%		84.1	84.1	84.1	86.4
Temperature Control			Microcomputer Control		Microcomputer Control	
Dimensions (HxWxD)	mm		288x800x204		288x800x204	
Packaged Dimensions (HxWxD)	mm		288x874x360		288x874x360	
Weight	kg		9		9	
Gross Weight	kg		13		13	
Operation Sound	H/M/L/SL	dBA	38 / 32 / 27 / 25	38 / 33 / 27 / 25	38 / 34 / 29 / 27	40 / 35 / 29 / 27
Outdoor Units			RY25GXV1		RYN35GXV1	
Casing Color			White		White	
Compressor	Type		Hermetic Motor Compressor		Hermetic Motor Compressor	
	Model		2PS156D5FB02		2PS206D5AB02	
	Motor Output	W	750		950	
Refrigerant Oil	Type		ATMOS NW56M or SUNISO 4GDID		ATMOS NW56M or SUNISO 4GDID	
	Charge	L	0.35		0.35	
Refrigerant	Type		R-22		R-22	
	Charge	kg	0.80		1.10	
Airflow Rate	m³/min		34.2	31.0	30.6	27.4
	cfm		1,207	1,094	1,080	966
Fan	Type		Propeller		Propeller	
	Motor Output	W	26		26	
Running Current	A		3.9	3.5	4.8	5.0
Power Consumption	W		843	763	1,023	1,062
Power Factor	%		98.3	99.1	96.9	96.5
Starting Current	A		18.5		21.5	
Dimensions (HxWxD)	mm		550x765x285		550x765x285	
Packaged Dimensions (HxWxD)	mm		358x611x899		358x611x899	
Weight	kg		30		34	
Gross Weight	kg		34		38	
Operation Sound		dBA	48	49	49	50
Drawing No.			3D060317		3D060318	

Note: ■ The data are based on the conditions shown in the table below.

Cooling	Heating	Piping Length
Indoor ; 27°CDB/19°CWB Outdoor ; 35°CDB/24°CWB	Indoor ; 20°CDB Outdoor ; 7°CDB/6°CWB	5m

Conversion Formulae
kcal/h=kWx860 Btu/h=kWx3414 cfm=m³/minx35.3

Part 3 Printed Circuit Board Connector Wiring Diagram

1. Printed Circuit Board Connector Wiring Diagram.....	10
1.1 Indoor Unit.....	10

1. Printed Circuit Board Connector Wiring Diagram

1.1 Indoor Unit

Connectors

- | | |
|------------|---|
| 1) S1 | Connector for fan motor |
| 2) S2, S4 | Connector for transformer |
| 3) S5 | Connector for thermal fuse |
| 4) S6 | Connector for swing motor (horizontal blades) |
| 5) S7 | Connector for fan motor (Hall IC) |
| 6) S26 | Connector for control PCB |
| 7) S27 | Connector for signal receiver PCB |
| 8) S32 | Connector for indoor heat exchanger thermistor |
| 9) S33 | Connector for outdoor heat exchanger thermistor |
| 10) H1 | Connector for compressor (outdoor unit) |
| 11) H2, H4 | Connector for four way valve (outdoor unit) |
| 12) H3 | Connector for fan motor (outdoor unit) |
| 13) H5 | Connector for power supply (outdoor unit) |



Note: Other designations

- | | |
|-----------|--|
| 1) V1, V2 | Varistor |
| 2) JA | Address setting jumper |
| JC | Power failure recovery function (auto restart) |
| | * Refer to page 107 for detail. |
| 3) SW1 | Forced operation ON/OFF switch |
| 4) LED1 | LED for operation (green) |
| 5) LED2 | LED for timer (yellow) |
| 6) LED A | LED for service monitor (green) |
| 7) FU1 | Fuse (3.15A) |
| 8) RTH | Room temperature thermistor |

Control PCB

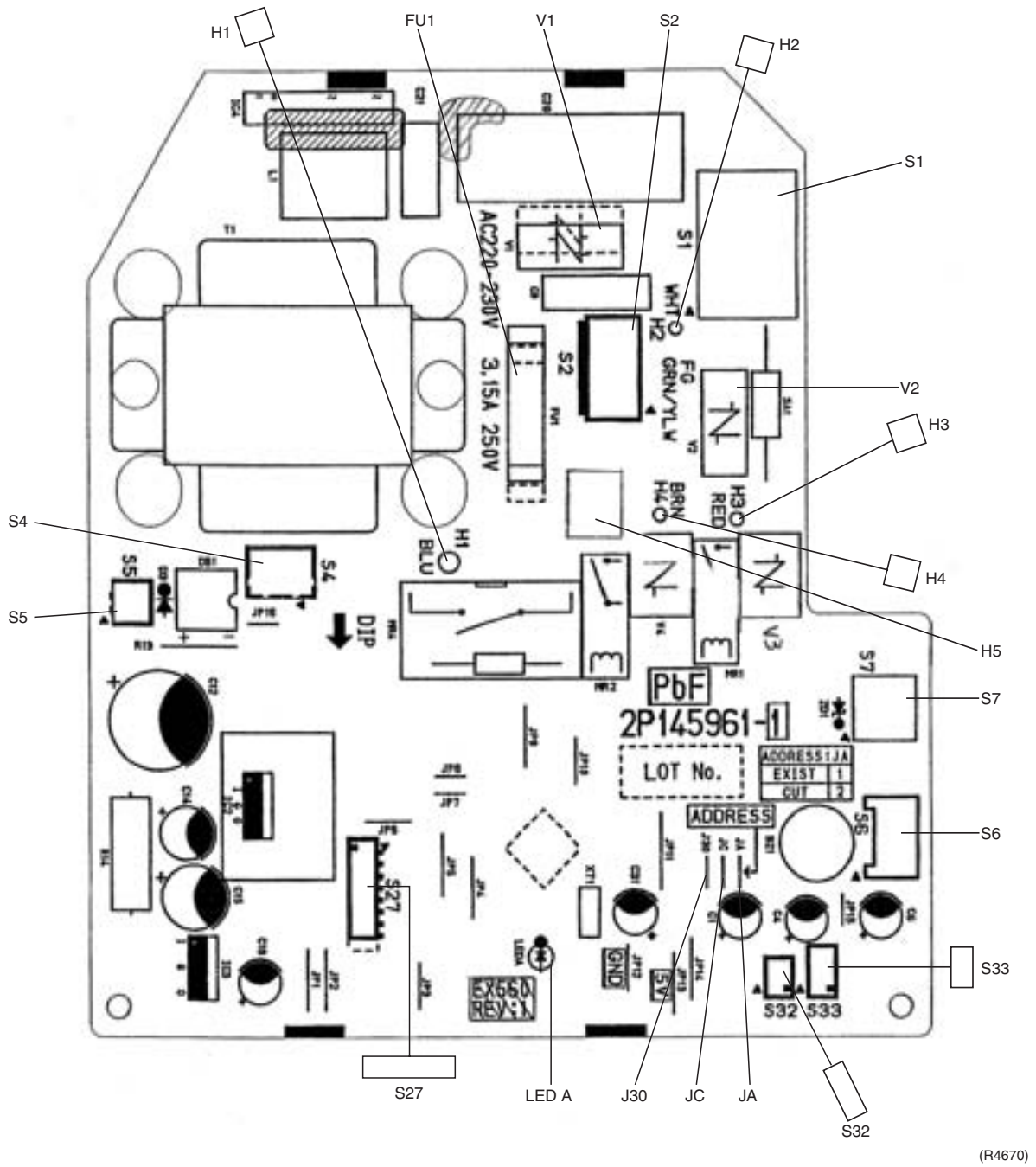

Signal Receiver PCB

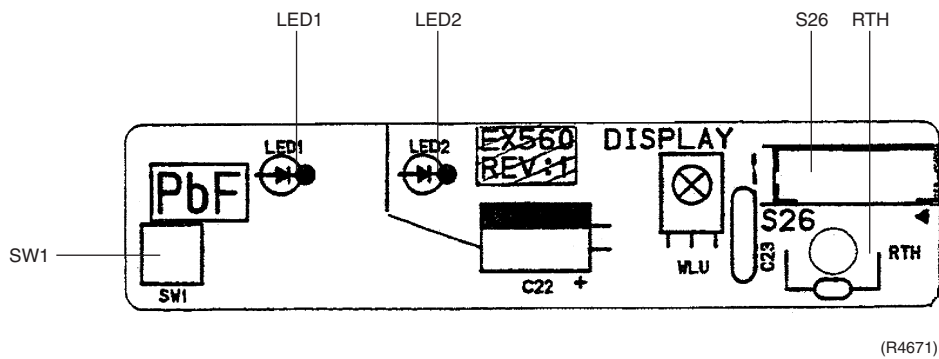

Part 4

Functions and Control

1. Functions.....	14
1.1 Power-Airflow Flap, Wide-Angle Louvers and Auto-Swing	14
1.2 Fan Speed Control for Indoor Units.....	15
1.3 Thermostat Control.....	16
1.4 Automatic Operation.....	17
1.5 Programme Dry Function	18
1.6 Sleep Operation	20
1.7 POWERFUL Operation	21
1.8 Other Functions.....	22
2. Function of Thermistor.....	23
3. Control Specification	24
3.1 Four Way Valve Switching	24
3.2 3-Minute Standby	24
3.3 Compressor Protection Function.....	24
3.4 Freeze-up Protection Control	24
3.5 Heating Peak-cut Control	25
3.6 Defrost Control	26

1. Functions

1.1 Power-Airflow Flap, Wide-Angle Louvers and Auto-Swing

Power-Airflow Flap

The large flap send a large volume of air downwards to the floor. The flap provides an optimum control area in cooling, heating and dry mode.

Heating Mode

During heating mode, the large flap enables direct warm air straight downwards. The flap presses the warm air above the floor to reach the entire room.

Cooling Mode

During cooling mode, the flap retracts into the indoor unit. Then, cool air can be blown far and pervaded all over the room.

Wide-Angle Louvers

The louvres, made of elastic synthetic resin, provide a wide range of airflow that guarantees a comfortable air distribution.

Auto-Swing

The following table explains the auto-swing process for heating, cooling, dry and fan :

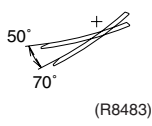
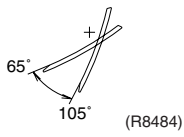
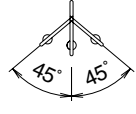
Vertical Swing (up and down)		Horizontal Swing (right and left: manual)
Cooling, Dry, Fan	Heating	
		

1.2 Fan Speed Control for Indoor Units

Control Mode

The airflow rate can be automatically controlled depending on the difference between the set temperature and the room temperature. This is done through phase control and Hall IC control.



For more information about Hall IC, refer to troubleshooting for fan motor on page 59.

Phase Steps

Phase control and fan speed control contains 5 steps: LL, L, M, H, and HH. You can choose the airflow rate between L and HH with the remote controller

Step	Cooling	Heating
LL (Quiet)	 (R8509)	 (R8510)
L		
M		
H		
HH (POWERFUL)		

○= The airflow rate is chosen from L-M-H tap when the fan setting button is set to automatic.



Note:

1. During POWERFUL operation, fan operates at 1280-1370rpm.
2. Fan stops during defrost operation.
3. In time of thermostat OFF, the fan rotates at following speed.
 Cooling : The fan keeps rotating at the set tap.
 Heating : The fan stops when the indoor heat exchanger temperature is below 18°C.

Airflow Rate Control for Heating

The following drawing explains the principle for fan speed control for heating:

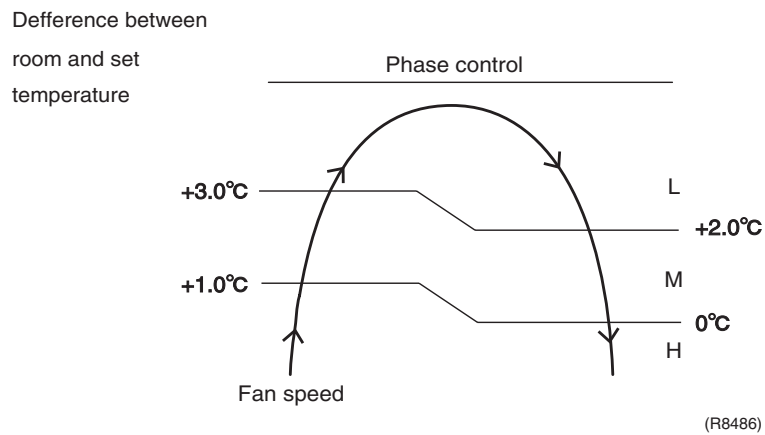

Airflow Rate Control for Cooling

The following drawing explains the principle of fan speed control for cooling:

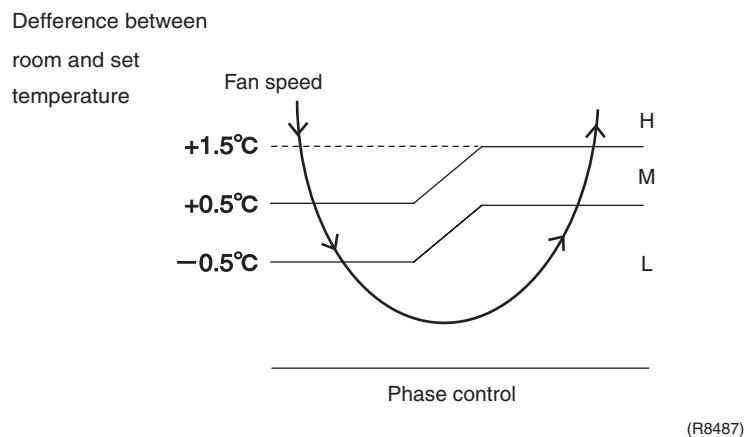

1.3 Thermostat Control

Thermostat control is based on the difference between the room temperature and the setpoint.

Cooling

Thermostat OFF: Room temperature – setpoint $\leq -1^{\circ}\text{C}$

Thermostat ON : Room temperature – setpoint $\geq +1.5^{\circ}\text{C}$

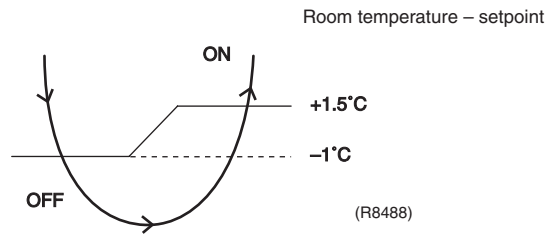

Heating

Thermostat OFF: Room temperature – setpoint $\geq +3.5^{\circ}\text{C}$

Thermostat ON : Room temperature – setpoint $\leq +1^{\circ}\text{C}$

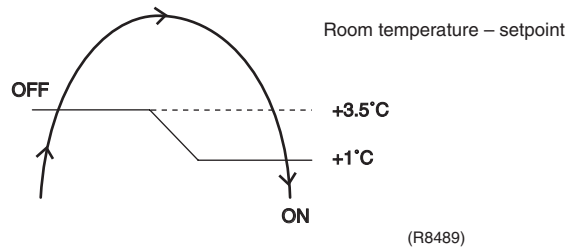

1.4 Automatic Operation

Outline

When the automatic mode is selected with the remote controller, the microcomputer determines the operation mode from cooling and heating according to the room temperature and the setpoint.

The unit automatically switches the operation mode to cooling or heating to maintain the room temperature.

Details of the Control

- ◆ Target temperature equals setpoint plus correction value (cooling: 0°C, heating: -1.5°C)
- ◆ Mode switching point and operation ON/OFF point are as follows.
 - ① Cooling → Heating: Room temperature - setpoint ≤ -3.5°C
 - ② Heating → Cooling: Room temperature - setpoint > +3°C
 - ③ Cooling thermostat ON : Room temperature - setpoint ≥ +1.5°C
Cooling thermostat OFF: Room temperature - setpoint ≤ -1°C
 - ④ Heating thermostat ON : Room temperature - setpoint ≤ -3.5°C
Heating thermostat OFF: Room temperature - setpoint ≥ -1°C

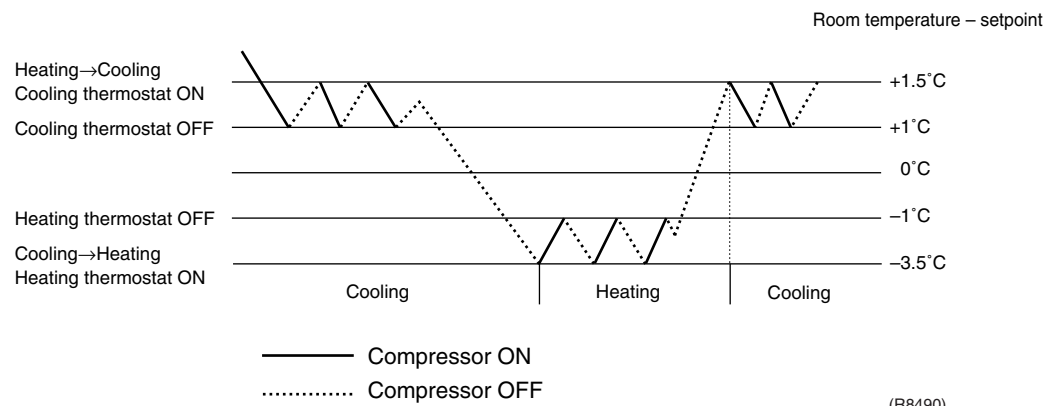

1.5 Programme Dry Function

Outline

Programme dry function removes humidity while preventing the room temperature from lowering.
 Since the microcomputer controls airflow rate, the fan adjustment buttons are inoperable in this mode.

Details of the Control

During the first 12 minutes of the DRY mode run from:
 1. After operation halt for 2 hours or more or
 2. Mode change from HEAT, FAN or AUTO HEAT
 DRY mode must run under cool mode with AUTO indoor fan for 12 minutes or until room temp. < set temp. - 1°C.

After this, the DRY mode may run under either Zone A, B, C or D as below:

1. If room temp. - set temp. > 2°C, the operation is in Zone A
ZONE A

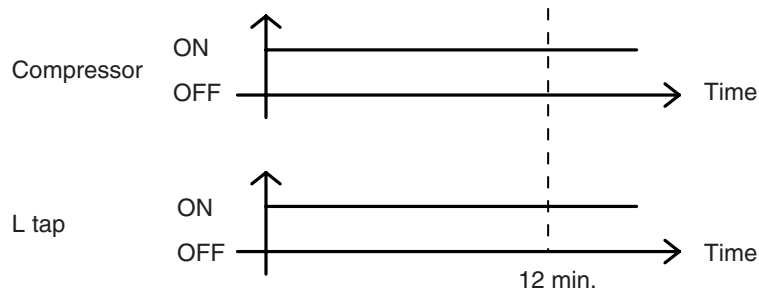

(R8491)

2. If 0°C < room temp. - set temp. < 1°C, then the operation is in Zone B.
ZONE B

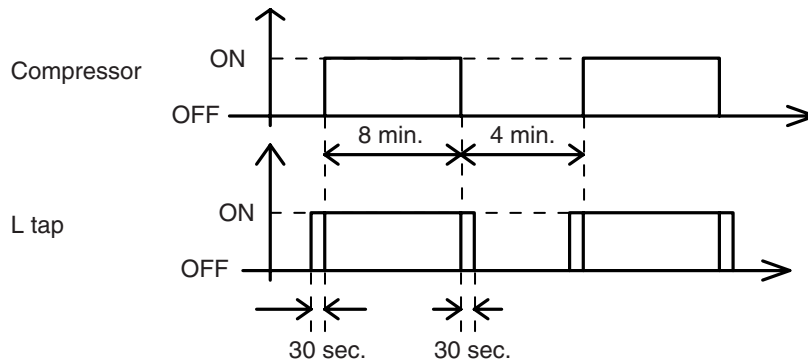

(R8492)

3. If 1°C < set temp. - room temp. < 2°C, then the operation is in Zone C.
ZONE C

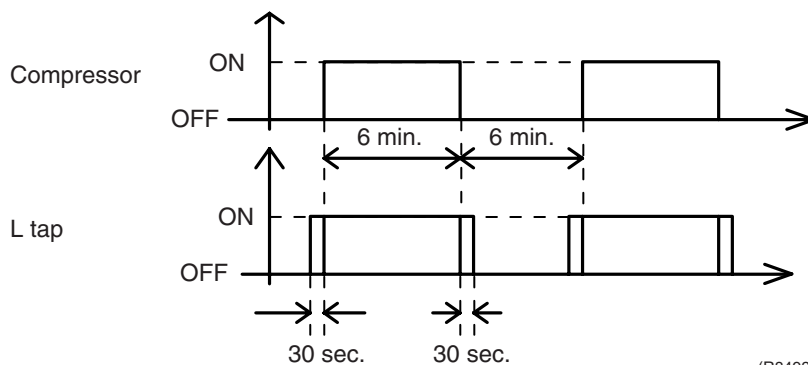

(R8493)

4. If set temp. – room temp. > 3°C, then the operation is in Zone D.
ZONE D

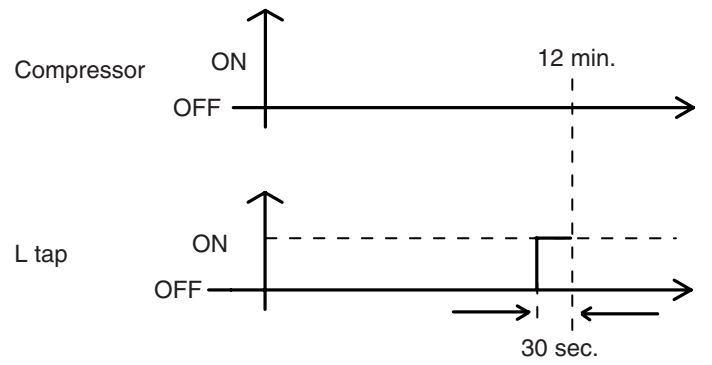

(R8494)

1.6 Sleep Operation

When the Sleep Operation is set, the Sleep Operation circuit activates.
The Sleep Operation circuit maintains the airflow setting made by users.

The Sleep Operation Circuit

- ◆ When the unit is operating under cooling mode, the set temperature is increased by 0.5°C after the first half an hour, 1°C after the second half an hour and total of 2°C after the following 1 hour. This function will prevent excessive cooling during summer season.
- ◆ When the unit is operating under heating mode, the set temperature is decreased by 1°C after the first half an hour, 2°C after the second half an hour and total of 3°C after the following 1 hour. This function will prevent night sweat during summer season.
- ◆ This function is available under COOL, HEAT and AUTO mode.

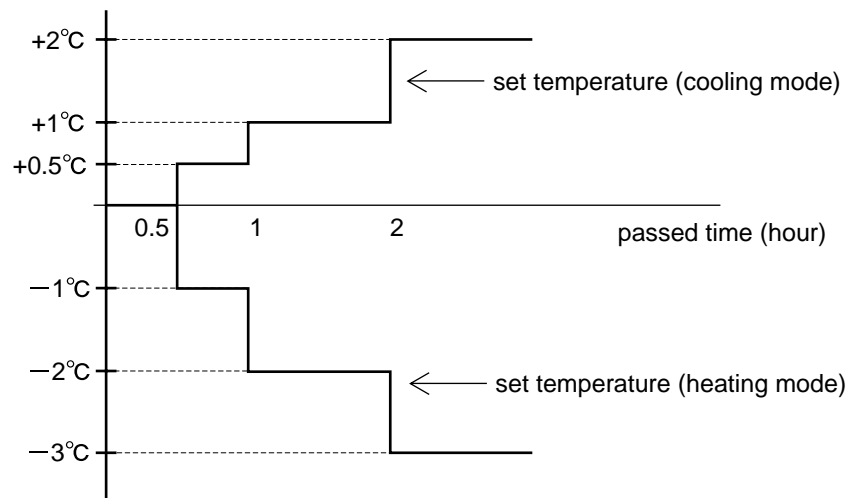

(R8495)

1.7 POWERFUL Operation

Outline

In order to exploit the cooling and heating capacity to full extent, operate the air conditioner by increasing the indoor fan rotating speed.

Details of the Control

When POWERFUL button is pushed, the fan speed and the target temperature will be converted to the following states for 20 minutes.

Operation mode	Fan speed	Target temperature
Cooling	HH tap	Set temp. -2°C
Heating	HH tap	Set temp. $+2^{\circ}\text{C}$

Ex.) : POWERFUL operation in cooling mode.

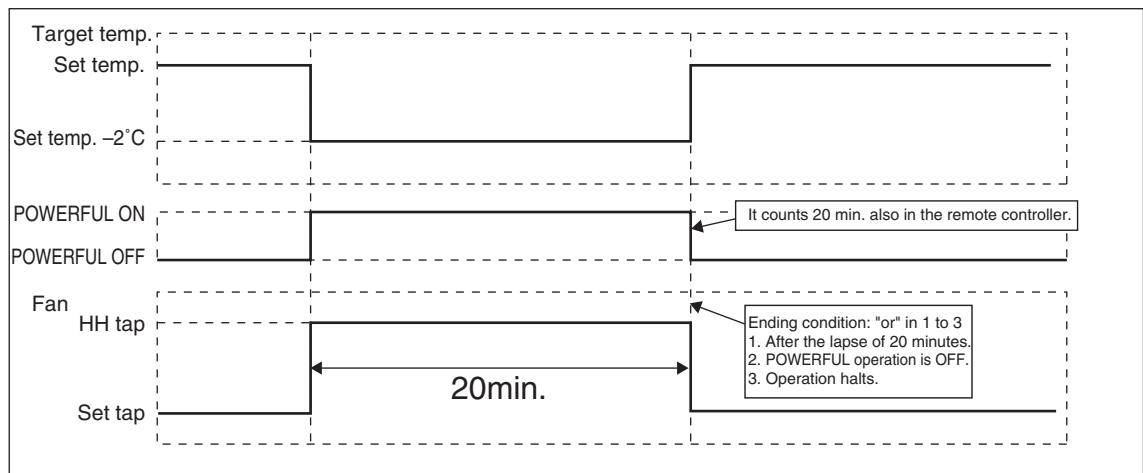

(R8496)

1.8 Other Functions

1.8.1 Hot Start Function

In order to prevent the cold draft that normally comes when heating operation starts, the temperature of the indoor heat exchanger is detected, and either the airflow is stopped or is made very weak thereby carrying out comfortable heating of the room.

*The cold draft is also prevented using a similar control when the thermostat turns OFF.

1.8.2 Signal Receiving Sign

When the indoor unit receives a signal from the remote controller, the unit emits a signal receiving sound.

1.8.3 ON/OFF Button on Indoor Unit

An ON/OFF button is provided on the front panel of the unit. Use this button when the remote controller is missing or if its battery has run out.

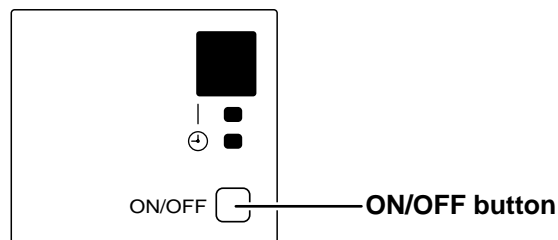

(R8512)

- ◆ Pressing the ON/OFF button cycles through the following operation modes: AUTO → OFF → AUTO → OFF, etc.
- ◆ The operation mode refers to the following table.

Mode	Temperature setting	Airflow rate
AUTO	25°C	AUTO

1.8.4 Titanium Apatite Photocatalytic Air-Purifying Filter

This filter combines the Air Purifying Filter and Titanium Apatite Photocatalytic Deodorizing Filter in a single highly effective unit. The filter traps microscopic particles, decompose odours and even deactivates bacteria and viruses. It lasts for three years without replacement if washed about once every six months.

1.8.5 Mold Proof Air Filter

The filter net is treated with mold resisting agent TBZ (harmless, colorless, and odorless). Due to this treatment, the amount of mold growth is much smaller than that of normal filters.

1.8.6 Self-Diagnosis Digital Display

The microcomputer continuously monitors operating conditions of the indoor unit, the outdoor unit, and the entire system. When an abnormality occurs, the remote controller displays error code on the LCD. These indications allow prompt maintenance operations.

1.8.7 Auto-restart Function

Even if a power failure (including one for just a moment) occurs during the operation, the operation restarts in the condition before power failure automatically when power is restored.

2. Function of Thermistor

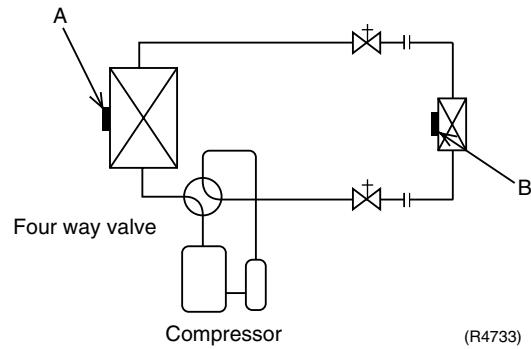

A Outdoor Heat Exchanger Thermistor

1. The outdoor heat exchanger thermistor is used for high pressure control during cooling operation.

B Indoor Heat Exchanger Thermistor

1. The indoor heat exchanger thermistor is used to prevent freezing. During the cooling operation, if the temperature drops abnormally, the operating frequency becomes lower, then the operation must be halted.
2. The indoor heat exchanger thermistor is used for high pressure control during heating operation.

3. Control Specification

3.1 Four Way Valve Switching

Outline Current is conducted during heating operation, and current is not conducted during cooling or defrosting. In order to eliminate the switching sound (as the four way valve coil switches from ON to OFF) when the heating is stopped, the delay switch of the four way valve is carried out after the operation stopped.

Detail The four way valve is switched 150 sec. after the compressor stops.

3.2 3-Minute Standby

Prohibit to turn ON the compressor for 3 minutes after turning it off.
(except when defrosting)

3.3 Compressor Protection Function

When the compressor turns ON, it keeps running at least 180 sec..
(except when defrosting)

3.4 Freeze-up Protection Control

Outline During cooling/dry operation, freeze-up protection control is activated according to the temperature of the indoor heat exchanger to prevent it freezing.

Detail

Conditions for starting

- ◆ Temperature of the indoor heat exchanger $\leq 1^{\circ}\text{C}$ for 1 min. or more
- ◆ Compressor running time ≥ 10 minutes

While controlling

- ◆ The compressor halts.

Conditions for ending

- ◆ Temperature of the indoor heat exchanger $\geq 10^{\circ}\text{C}$ for 1 min. or more
- or
- ◆ The operation stops.

3.5 Heating Peak-cut Control

Outline During heating operation, heating peak-cut control is activated according to the temperature of the indoor heat exchanger to prevent abnormal high pressure.

Detail

Conditions for starting

- ◆ Temperature of the indoor heat exchanger > 68°C.

While controlling

- ◆ The compressor halts.
- ◆ The outdoor fan switches ON/OFF according to the temperature of the indoor heat exchanger.

Conditions for ending

- ◆ Temperature of the indoor heat exchanger < 50°C (only for the first time)
- or
- ◆ Reset manually by pressing ON/OFF button (for the second time).

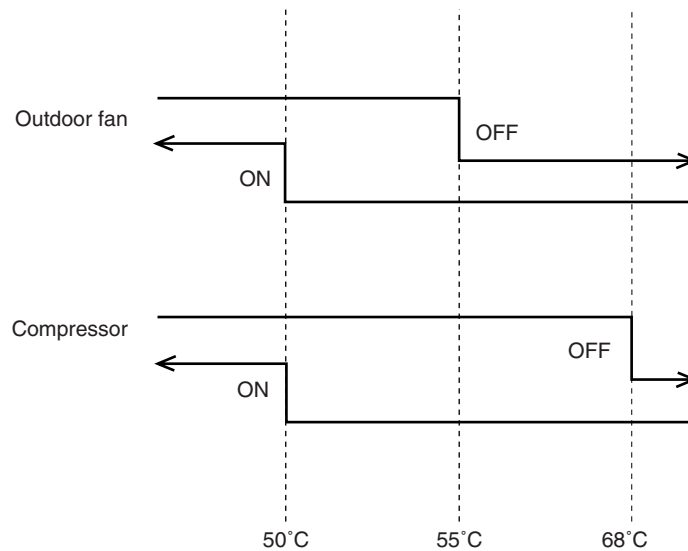

(R8497)

3.6 Defrost Control

Outline

In heating, defrosting is carried out by the cooling cycle (reverse cycle) to prevent the outdoor heat exchanger being frosted. The defrosting time or outdoor heat exchanger temperature must be more than its fixed value when finishing.

Detail

Time chart

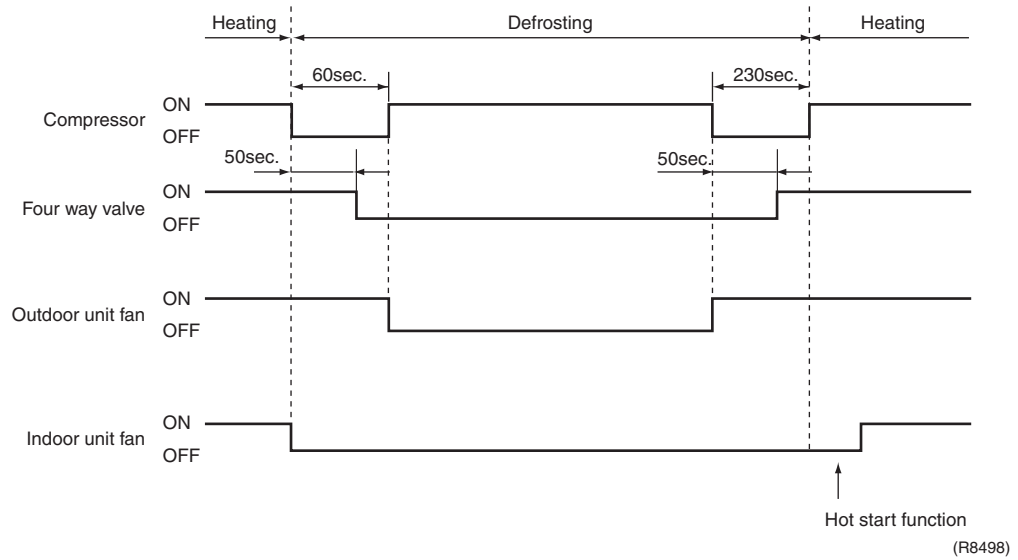

Part 5

Operation Manual

- 1. System Configuration.....28
- 2. Instructions29
 - 2.1 Safety Precautions29
 - 2.2 Names of Parts.....31
 - 2.3 Preparation Before Operation34
 - 2.4 AUTO • DRY • COOL • HEAT • FAN Operation37
 - 2.5 Adjusting the Airflow Direction.....39
 - 2.6 POWERFUL Operation40
 - 2.7 QUIET Operation.....41
 - 2.8 TIMER Operation42
 - 2.9 PERSONALIZE Operation43
 - 2.10 SLEEP Operation44
 - 2.11 Care and Cleaning45
 - 2.12 Troubleshooting.....48

1. System Configuration

After the installation and test operation of the room air conditioner have been completed, it should be operated and handled as described below. Every user would like to know the correct method of operation of the room air conditioner, to check if it is capable of cooling (or heating) well, and to know a clever method of using it.

In order to meet this expectation of the users, giving sufficient explanations taking enough time can be said to reduce about 80% of the requests for servicing. However good the installation work is and however good the functions are, the customer may blame either the room air conditioner or its installation work because of improper handling. The installation work and handing over of the unit can only be considered to have been completed when its handling has been explained to the user without using technical terms but giving full knowledge of the equipment.

2. Instructions

i Note: This instruction is for FTYN models as representative.

2.1 Safety Precautions

Safety precautions





- Keep this manual where the operator can easily find them.
- Read this manual attentively before starting up the unit.
- For safety reason the operator must read the following cautions carefully.
- This manual classifies precautions into WARNING and CAUTION. Be sure to follow all precautions below: they are all important for ensuring safety.

WARNING



If you do not follow these instructions exactly, the unit may cause property damage, personal injury or loss of life.

CAUTION

If you do not follow these instructions exactly, the unit may cause minor or moderate property damage or personal injury.

-  Never do.
-  Be sure to earth the air conditioner.
-  Never touch the air conditioner (including the remote controller) with a wet hand.
-  Be sure to follow the instructions.
-  Never cause the air conditioner (including the remote controller) to get wet.

WARNING

- In order to avoid fire, explosion or injury, do not operate the unit when harmful, among which flammable or corrosive gases, are detected near the unit. 
- It is not good for health to expose your body to the air flow for a long time.
- Do not put a finger, a rod or other objects into the air outlet or inlet. As the fan is rotating at a high speed, it will cause injury.
- Do not attempt to repair, relocate, modify or reinstall the air conditioner by yourself. Incorrect work will cause electric shocks, fire etc.
For repairs and reinstallation, consult your Daikin dealer for advice and information.
- The refrigerant used in the air conditioner is safe. Although leaks should not occur, if for some reason any refrigerant happens to leak into the room, make sure it does not come in contact with any flame as of gas heaters, kerosene heaters or gas range. 
- If the air conditioner is not cooling (heating) properly, the refrigerant may be leaking, so call your dealer. When carrying out repairs accompanying adding refrigerant, check the content of the repairs with our service staff.
- Do not attempt to install the air conditioner by your self. Incorrect work will result in water leakage, electric shocks or fire. For installation, consult the dealer or a qualified technician.
- In order to avoid electric shock, fire or injury, if you detect any abnormally such as smell of fire, stop the operation and turn off the breaker. And call your dealer for instructions.
- Depending on the environment, an earth leakage breaker must be installed. Lack of an earth leakage breaker may result in electric shocks or fire.
- The air conditioner must be earthed. Incomplete earthing may result in electric shocks. Do not connect the earth line to a gas pipe, water pipe, lightning rod, or a telephone earth line. 

CAUTION

- In order to avoid any quality deterioration, do not use the unit for cooling precision instruments, food, plants, animals or works of art. 
- Never expose little children, plants or animals directly to the air flow.
- Do not place appliances which produce open fire in places exposed to the air flow from the unit or under the indoor unit. It may cause incomplete combustion or deformation of the unit due to the heat.

- Do not block air inlets nor outlets. Impaired air flow may result in insufficient performance or trouble.
- Do not stand or sit on the outdoor unit. Do not place any object on the unit to avoid injury, do not remove the fan guard.
- Do not place anything under the indoor or outdoor unit that must be kept away from moisture. In certain conditions, moisture in the air may condense and drip.
- After a long use, check the unit stand and fittings for damage.
- Do not touch the air inlet and aluminum fins of outdoor unit. It may cause injury.
- The appliance is not intended for use by young children or infirm persons without supervision.
- Young children should be supervised to ensure that they do not play with the appliance.

- To avoid oxygen deficiency, ventilate the room sufficiently if equipment with burner is used together with the air conditioner.
- Before cleaning, be sure to stop the operation, turn the breaker off or pull out the supply cord.
- Do not connect the air conditioner to a power supply different from the one as specified. It may cause trouble or fire.
- Arrange the drain hose to ensure smooth drainage. Incomplete draining may cause wetting of the building, furniture etc.
- Do not place objects in direct proximity of the outdoor unit and do not let leaves and other debris accumulate around the unit.
Leaves are a hotbed for small animals which can enter the unit. Once in the unit, such animals can cause malfunctions, smoke or fire when making contact with electrical parts.



- Do not operate the air conditioner with wet hands.



- Do not wash the indoor unit with excessive water, only use a slightly wet cloth.
- Do not place things such as vessels containing water or anything else on top of the unit. Water may penetrate into the unit and degrade electrical insulations, resulting in an electric shock.



Installation site.

- To install the air conditioner in the following types of environments, consult the dealer.
 - Places with an oily ambient or where steam or soot occurs.
 - Salty environment such as coastal areas.
 - Places where sulfide gas occurs such as hot springs.
 - Places where snow may block the outdoor unit.

The drain from the outdoor unit must be discharged to a place of good drainage.

Consider nuisance to your neighbours from noises.

- For installation, choose a place as described below.
 - A place solid enough to bear the weight of the unit which does not amplify the operation noise or vibration.
 - A place from where the air discharged from the outdoor unit or the operation noise will not annoy your neighbours.

Electrical work.

- For power supply, be sure to use a separate power circuit dedicated to the air conditioner.

System relocation.

- Relocating the air conditioner requires specialized knowledge and skills. Please consult the dealer if relocation is necessary for moving or remodeling.

2.2 Names of Parts

Names of parts

■ Indoor Unit

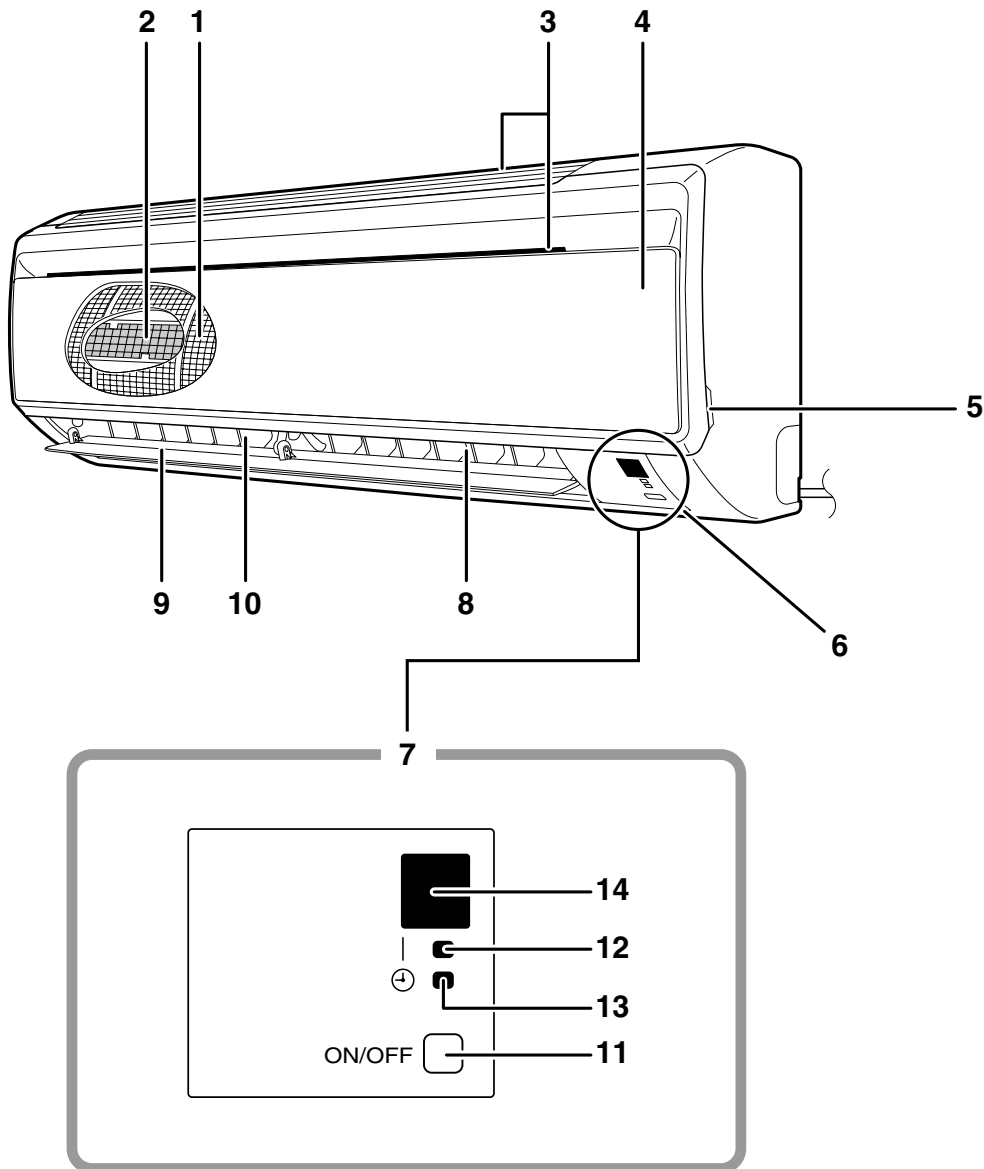

■ Outdoor Unit

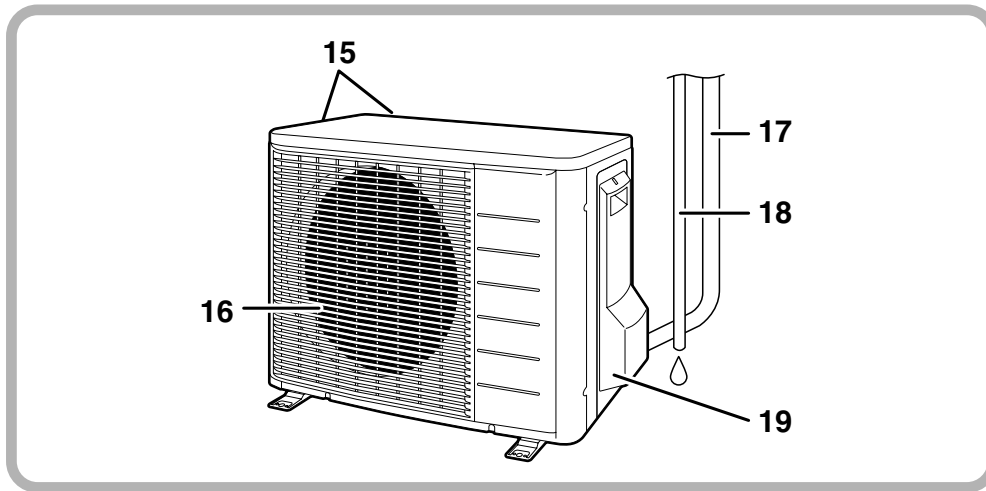

■ Indoor Unit

1. Air filter
2. Air purifying filter with bacteriostatic, virustatic functions:
 - These filters are attached to the inside of the air filters.
3. Air inlet
4. Front panel
5. Panel tab
6. Room temperature sensor:
 - It senses the air temperature around the unit.
7. Display
8. Air outlet
9. Horizontal blades (Flaps): (page 12.)
10. Vertical blades (Louvers):
 - The louvers are inside of the air outlet. (page 12.)

11. Indoor Unit ON/OFF switch:

- Push this switch once to start operation. Push once again to stop it.
- The operation mode refers to the following table.

Mode	Temperature setting	Airflow rate
AUTO	25°C	AUTO

- This switch is useful when the remote controller is missing.

12. Operation lamp (green)

13. TIMER lamp (yellow): (page 15.)

14. Signal receiver:

- It receives signals from the remote controller.
- When the unit receives a signal, you will hear a short beep.
 - Operation startbeep-beep
 - Settings changed.....beep
 - Operation stopbeeeeeep

■ Outdoor Unit

15. Air inlet: (Back and side)
16. Air outlet
17. Refrigerant piping and inter-unit cable
18. Drain hose
19. Earth terminal:
 - It is inside of this cover.

Appearance of the outdoor unit may differ from some models.

■ Remote Controller

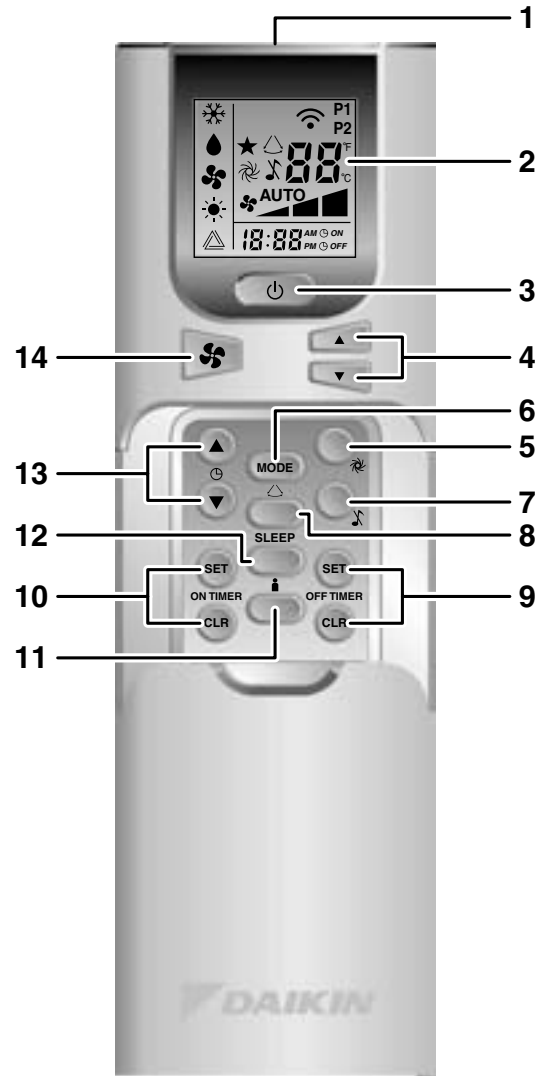

<ARC461A1>

- 1. Signal transmitter:**
 - It sends signals to the indoor unit.
- 2. Display:**
 - It displays the current settings.
(In this illustration, each section is shown with all its displays ON for the purpose of explanation.)
- 3. ON/OFF button:**
 - Press this button once to start operation.
 - Press once again to stop it.
- 4. TEMPERATURE adjustment buttons:**
 - It changes the temperature setting.
- 5. POWERFUL button:**
POWERFUL operation (page 13.)
- 6. MODE selector button:**
 - To select the type of operation mode.
(COOL (❄️) / DRY (💧) / FAN (🌀) / HEAT (☀️) / AUTO (⚙️)) (page 10.)
- 7. QUIET button:**
QUIET operation (page 14.)
- 8. SWING button:**
 - Adjusting the airflow direction. (page 12.)
- 9. OFF TIMER button:** (page 15.)
- 10. ON TIMER button:** (page 15.)
- 11. PERSONALIZED button:** (page 16.)
- 12. SLEEP button:** (page 17.)
- 13. CLOCK button:** (page 9.)
- 14. FAN setting button:**
 - It selects the airflow rate setting.
(page 11.)

2.3 Preparation Before Operation

Preparation Before Operation

■ To set the batteries

1. Slide the battery cover by pulling it according to the arrow direction.
2. Insert new batteries making sure that the (+) and (-) of battery are installed correctly.
3. Reattach the cover by sliding it back into position.

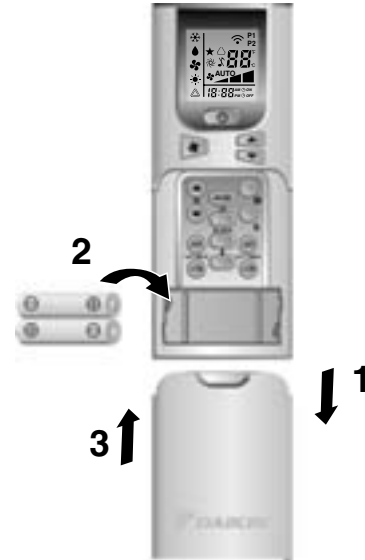

ATTENTION

■ About batteries

- When replacing the batteries, use batteries of the same type, and replace the two old batteries together.
- When the system is not used for a long time, take the batteries out.
- The batteries will last for approximately one year. If the remote controller display begins to fade and the degradation of reception performance occurs within a year, however, replace both two batteries with new size AAA alkaline batteries.
- The attached batteries are provided for the initial use of the system.
The usable period of the batteries may be short depending on the manufactured date of the air conditioner.

Preparation Before Operation

■ To operate the remote controller

- To use the remote controller, aim the transmitter at the indoor unit. If there is anything to block signals between the unit and the remote controller, such as a curtain, the unit will not operate.
- Do not drop the remote controller. Do not get it wet.
- The maximum distance for communication is about 7m.

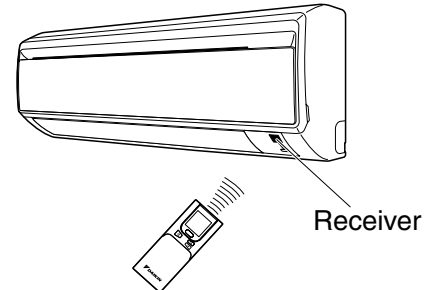

■ To fix the remote controller holder on the wall

1. Choose a place from where the signals reach the unit.
Fix the holder to a wall, a pillar, or similar location with the screws procured locally.
2. Place the remote controller in the remote controller holder vertically.
3. Remove the remote controller from the remote controller holder vertically if necessary.

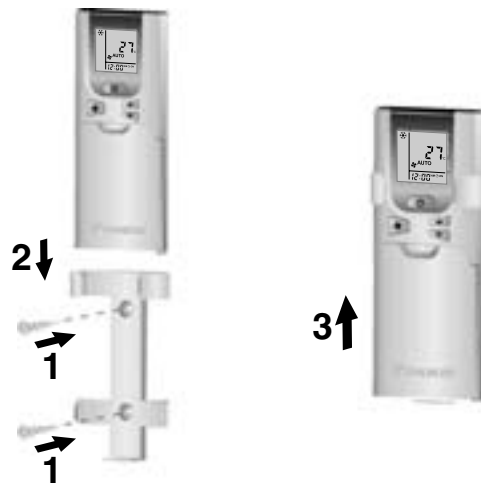

ATTENTION

■ About remote controller

- Never expose the remote controller to direct sunlight.
- Dust on the signal transmitter or receiver will reduce the sensitivity. Wipe off dust with soft cloth.
- Signal communication may be disabled if an electronic-starter-type fluorescent lamp (such as inverter-type lamps) is in the room. Consult the shop if that is the case.
- If the remote controller signals happen to operate another appliance, move that appliance to somewhere else, or consult the shop.

■ **To set the clock**

1. Hold down “▲” or “▼” button for 2 seconds.
2. Press “▲” button to increase the clock time.
3. Press “▼” button to decrease the clock time.
4. Leave the remote controller for 4 seconds without pressing any button.



NOTE

■ **Tips for saving energy**

- Be careful not to cool (heat) the room too much. Keeping the temperature setting at a moderate level helps save energy.
- Cover windows with a blind or a curtain. Blocking sunlight and air from outdoors increases the cooling (heating) effect.
- Clogged air filters cause inefficient operation and waste energy. Clean them once in about every two weeks.

Recommended temperature setting
For cooling: 26°C – 28°C
For heating: 20°C – 24°C

■ **Please note**

- The air conditioner always consumes 5 watts of electricity even while it is not operating.
- If you are not going to use the air conditioner for a long period, for example in spring or autumn, turn the breaker OFF.
- Use the air conditioner in the following conditions.

Mode	Operating conditions	If operation is continued out of this range
COOL	Outdoor temperature: 10 to 46°C Indoor temperature: 16 to 30°C Indoor humidity: 80% max.	<ul style="list-style-type: none"> • A safety device may work to stop the operation. • Condensation may occur on the indoor unit and drip.
HEAT	Outdoor temperature: –10 to 24°C Indoor temperature: 10 to 30°C	<ul style="list-style-type: none"> • A safety device may work to stop the operation.
DRY	Outdoor temperature: 10 to 46°C Indoor temperature: 16 to 30°C Indoor humidity: 80% max.	<ul style="list-style-type: none"> • A safety device may work to stop the operation. • Condensation may occur on the indoor unit and drip.

- Operation outside this humidity or temperature range may cause a safety device to disable the system.

2.4 AUTO • DRY • COOL • HEAT • FAN Operation

AUTO • DRY • COOL • HEAT • FAN Operation

The air conditioner operates with the operation mode of your choice. From the next time on, the air conditioner will operate with the same operation mode.

■ To start operation

1. Press “MODE selector button” and select a operation mode.

- Each pressing of the button advances the mode setting in sequence.

- ❄️ : COOL
- 💧 : DRY
- 🌀 : FAN
- ☀️ : HEAT
- ⚙️ : AUTO

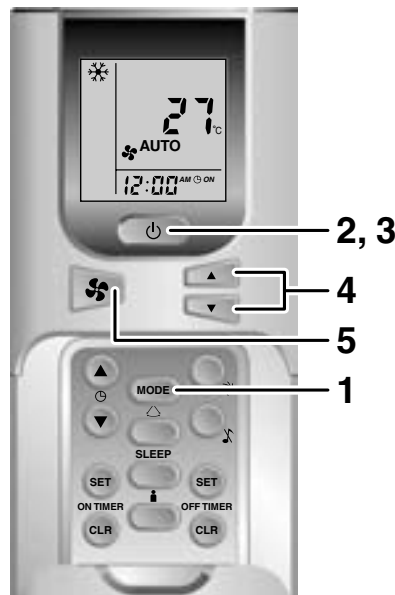
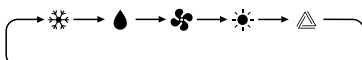

2. Press “ON/OFF button”.

- The OPERATION lamp lights up.

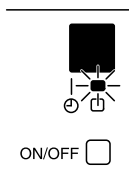

■ To stop operation

3. Press “ON/OFF button” again.

- Then OPERATION lamp goes off.

■ To change the temperature setting

4. Press “TEMPERATURE adjustment button”.

DRY or FAN mode	AUTO or COOL or HEAT mode
The temperature setting is not variable.	Press “▲” to raise the temperature and press “▼” to lower the temperature.
	Set to the temperature you like. 27 °C

- If you want to change the temperature unit (°C ↔ °F), press “▲” and “▼” simultaneously.

■ To change the airflow rate setting

5. Press “FAN setting button”.

DRY mode	AUTO or COOL or HEAT or FAN mode
The airflow rate setting is not variable.	<p>3 levels of airflow rate setting from “▲” to “■” plus “AUTO” are available.</p> 

NOTE

■ Note on HEAT operation

- Since this air conditioner heats the room by taking heat from outdoor air to indoors, the heating capacity becomes smaller in lower outdoor temperatures. If the heating effect is insufficient, it is recommended to use another heating appliance in combination with the air conditioner.
- The heat pump system heats the room by circulating hot air around all parts of the room. After the start of heating operation, it takes some time before the room gets warmer.
- In heating operation, frost may occur on the outdoor unit and lower the heating capacity. In that case, the system switches into defrosting operation to take away the frost.
- During defrosting operation, hot air does not flow out of indoor unit.

■ Note on COOL operation

- This air conditioner cools the room by blowing the hot air in the room outside, so if the outside temperature is high, the performance of the air conditioner drops.

■ Note on DRY operation

- The computer chip works to rid the room of humidity while maintaining the temperature as much as possible. It automatically controls temperature and airflow rate, so manual adjustment of these functions is unavailable.

■ Note on AUTO operation

- In AUTO operation, the system selects an appropriate operation mode (COOL or HEAT) based on the room temperature at the start of the operation.
- The system automatically reselects setting at a regular interval to bring the room temperature to user-setting level.
- If you do not like AUTO operation, manually change the set temperature.

■ Note on airflow rate setting

- At smaller airflow rates, the cooling (heating) effect is also smaller.

2.5 Adjusting the Airflow Direction

Adjusting the Airflow Direction

You can adjust the airflow direction to increase your comfort.

■ To adjust the horizontal blades (flaps)

1. Press “SWING button”.

- “” is displayed on the LCD and the flaps will begin to swing.

2. When the flaps have reached the desired position, press “SWING button” once more.

- The flap will stop moving.
- “” disappears from the LCD.



■ To adjust the vertical blades (louvers)

Hold the knob and move the louvers.
(You will find a knob on the left-side and the right-side blades.)

- When the unit is installed in the corner of a room, the direction of the louvers should be facing away from the wall.
If they face the wall, the wall will block off the wind, causing the cooling (or heating) efficiency to drop.

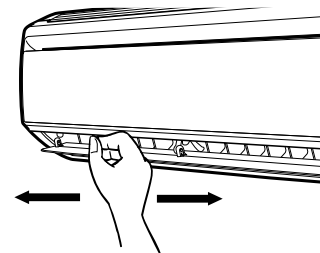

Notes on flaps and louvers angles

- When “**SWING button**” is selected, the flaps swinging range depends on the operation mode. (See the figure.)

■ ATTENTION

- Always use a remote controller to adjust the flaps angle. If you attempt to move it forcibly with hand when it is swinging, the mechanism may be broken.
- Be careful when adjusting the louvers. Inside the air outlet, a fan is rotating at a high speed.

In COOL, DRY, and FAN mode

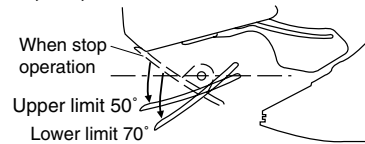

In HEAT mode

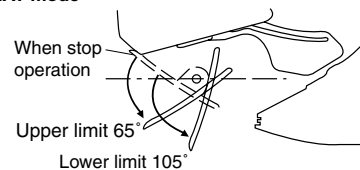

2.6 POWERFUL Operation

POWERFUL Operation

POWERFUL operation quickly maximizes the cooling (heating) effect in any operation mode. You can get the maximum capacity.

■ To start POWERFUL operation

1. Press “POWERFUL button”.

- POWERFUL operation ends in 20minutes. Then the system automatically operates again with the previous settings which were used before POWERFUL operation.
- “” is displayed on the LCD.

■ To cancel POWERFUL operation

2. Press “POWERFUL button” again.

- “” disappears from the LCD.



NOTE

■ Notes on POWERFUL operation

- POWERFUL Operation cannot be used together with QUIET Operation. (page 14.) Priority is given to the function of whichever button is pressed first.
- POWERFUL Operation can only be set when the unit is running. Pressing the operation stop button causes the settings to be canceled, and the “” disappears from the LCD.
- **In DRY and FAN mode**
POWERFUL Operation is not available.

2.7 QUIET Operation

QUIET Operation

QUIET operation lowers the noise level of the indoor unit by changing the airflow rate minimum. Use this when making the noise quieter.

■ To start QUIET operation

1. Press “QUIET button”.
 - “” displayed on the LCD.

■ To cancel QUIET operation

2. Press “QUIET button” again.
 - “” disappears from the LCD.



NOTE

■ Note on QUIET operation

- QUIET operation cannot be used together with POWERFUL operation. Priority is given to the function of whichever button is pressed first.
- The unit might lose capacity when QUIET operation.
- **In DRY mode and FAN mode**
QUIET operation is not available.

2.8 TIMER Operation

TIMER Operation

Timer functions are useful for automatically switching the air conditioner on or off at night or in the morning. You can also use OFF TIMER and ON TIMER in combination.

■ To use OFF TIMER operation

- Check that the clock is correct.
If not, set the clock to the present time. (page 9.)
- 1. Press “OFF TIMER SET button” until the indicated time reaches the point you like.
 - Every pressing of the button increases the time setting by 30 minutes.
Holding down the button changes the setting rapidly.
 -  OFF is displayed.
 - The TIMER lamp lights up.

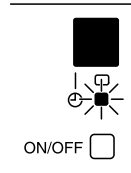

■ To cancel the OFF TIMER operation

2. Press “OFF TIMER CLR button”.
 - The TIMER lamp goes off.
 -  OFF disappears.

NOTE

- Once you set ON, OFF TIMER, the time setting is kept in the memory.
- When operating the unit via the ON/OFF Timer, the actual length of operation may vary from the time entered by the user.

■ To use ON TIMER operation

- Check that the clock is correct. If not, set the clock to the present time. (page 9.)
- 3. Press “ON TIMER SET button” until the indicated time reaches the point you like.
 - Every pressing of the button increased the time setting by 30 minutes.
Holding down the button changes the setting rapidly.
 -  ON is displayed.
 - The TIMER lamp lights up.

■ To cancel the ON TIMER operation

4. Press “ON TIMER CLR button”.
 - The TIMER lamp goes off.
 -  ON disappears.

ATTENTION

- In the following cases, set the timer again.
 - After a breaker has turned OFF.
 - After a power failure.
 - After replacing batteries in the remote controller.

2.9 PERSONALIZE Operation

PERSONALIZE Operation

PERSONALIZE operation is the function which allows you to record your preferred settings. You can set your preferred setting one time by using this function.

■ To set PERSONALIZE operation

1. Hold down “PERSONALIZED button” until “P1” blinks.
 - Press again to cycle between “P1” and “P2”.
Choose P1 or P2.
2. Set your preferred setting.
3. Leave the remote controller for 15 seconds without pressing any button and it will save the setting into the programme.



1, 4

■ To use PERSONALIZE operation

4. Press “PERSONALIZED button” once to activate the “P1” setting, and press again to cycle between “P1” and “P2”.
 - Press any key to deactivate the personalized setting.

2.10 SLEEP Operation

SLEEP Operation

When set SLEEP operation, the air conditioner automatically adjusts the temperature setting.

■ To set SLEEP operation

1. Press "SLEEP button".

- ★ is displayed.

■ To cancel SLEEP operation

2. Press "SLEEP button" again.

- ★ disappears.



NOTE

■ Note on SLEEP operation

- When the unit is operating under cooling mode, the set temperature is increased by 0.5°C after the first half an hour, 1°C after the second half an hour and total of 2°C after the following 1 hour. This function will prevent excessive cooling during summer season.
- When the unit is operating under heating mode, the set temperature is decreased by 1°C after the first half an hour, 2°C after the second half an hour and total of 3°C after the following 1 hour. This function will prevent night sweat during summer season.
- This function is available under COOL, HEAT and AUTO mode.

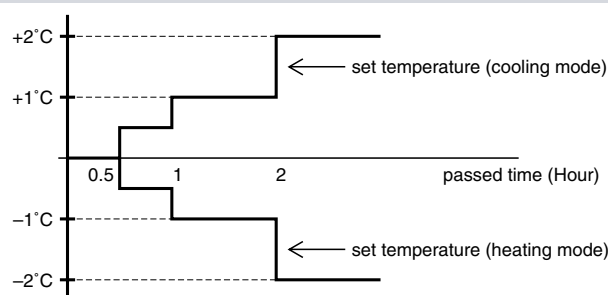

2.11 Care and Cleaning

Care and Cleaning

⚠ CAUTION Before cleaning, be sure to stop the operation and turn the breaker OFF.

Units

■ Indoor unit, Outdoor unit and Remote controller

1. Wipe them with dry soft cloth.

■ Front panel

1. Open the front panel.

- Hold the panel at the recesses on the main unit (2 recesses on right and left sides) and lift it until it stops.

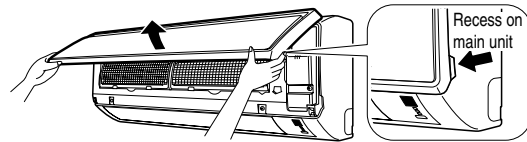

2. Remove the front panel.

- While lifting the front panel further, slide it to the right and pull it to the front side. The left rotating shaft is detached. Slide the right rotating shaft to the left and pull it to the front side to remove it.

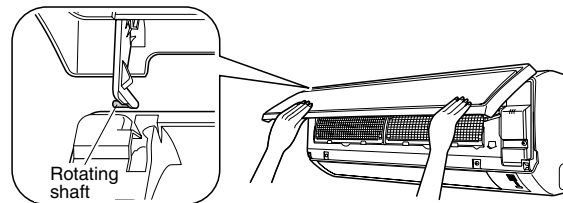

3. Attach the front panel.

- Align the right and left rotating shafts of the front panel with the grooves and push them all the way in.
- Gently close the front panel. (Push both ends and the center on the front panel.)

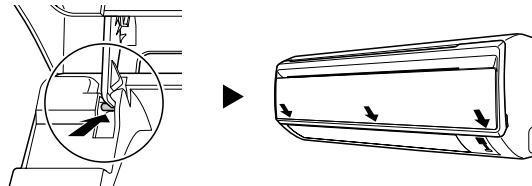

⚠ CAUTION

- Don't touch the metal parts of the indoor unit. If you touch those parts, this may cause an injury.
- When removing or attaching the front panel, use a robust and stable stool and watch your steps carefully.
- When removing or attaching the front panel, support the panel securely with hand to prevent it from falling.
- For cleaning, do not use hot water above 40°C, benzene, gasoline, thinner, nor other volatile oils, polishing compound, scrubbing brushes, nor other hand stuff.
- After cleaning, make sure that the front panel is securely fixed.

Filters

1. Open the front panel. (page 18.)

- Hold the panel at the recesses on the main unit (2 recesses on right and left sides) and lift it until it stops.

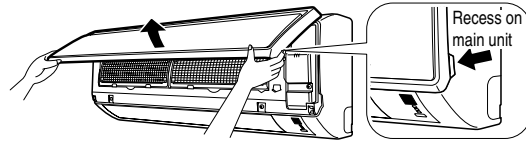

2. Pull out the air filters.

- Push a little upwards the tab at the center of each air filter, then pull it down.

3. Take off the Air purifying filter with bacteriostatic, virustatic functions.

- Hold the recessed parts of the frame and unhook the four claws.

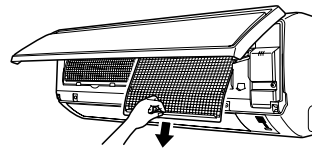

4. Clean or replace each filter.

See figure.

- When shaking off remaining water, do not wring the filter.

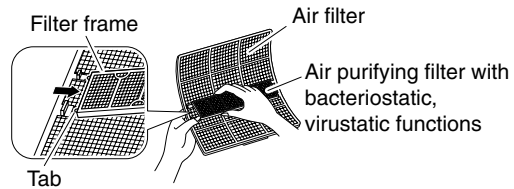

5. Set the air filter and Air purifying filter with bacteriostatic, virustatic functions as they were and close the front panel.

- Insert claws of the filters into slots of the front panel. Close the front panel slowly and push the panel at the 3 points. (1 on each side and 1 in the middle.)
- The air filter and the Air purifying filter with bacteriostatic, virustatic functions have a symmetrical form in the horizontal direction.

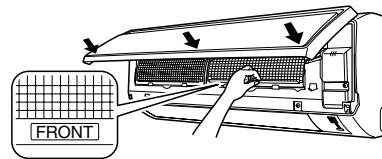

■ Air Filter

1. Wash the air filters with water or clean them with vacuum cleaner.

- If the dust does not come off easily, wash them with neutral detergent thinned with lukewarm water, then dry them up in the shade.
- It is recommended to clean the air filters every two weeks.

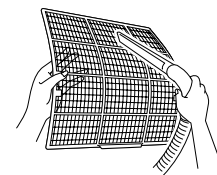

■ Air purifying filter with bacteriostatic, virustatic functions

The Air purifying filter with bacteriostatic, virustatic functions can be renewed by washing it with water once every 6 months. We recommend replacing it once every 3 years.

[Maintenance]

1. Remove dust with a vacuum cleaner and wash lightly with water.
2. If it is very dirty, soak it for 10 to 15 minutes in water mixed with a neutral cleaning agent.
3. Do not remove filter from frame when washing with water.
4. After washing, shake off remaining water and dry in the shade.
5. When shaking off remaining water, do not wring the filter.

[Replacement]

1. Remove the tabs on the filter frame and replace with a new filter.

- Dispose of old filters as non-flammable waste.

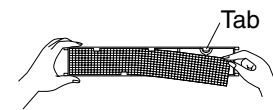

NOTE

- Operation with dirty filters:
 - (1) cannot deodorize the air.
 - (2) cannot clean the air.
 - (3) results in poor heating or cooling.
 - (4) may cause odour.
- To order Air purifying filter with bacteriostatic, virustatic functions contact to the service shop there you bought the air conditioner.
- Dispose of old filters as non-flammable waste.

Item	Part No.
Air purifying filter with bacteriostatic, virustatic functions (without frame) 1 set	KAF992A42

Check

Check that the base, stand and other fittings of the outdoor unit are not decayed or corroded.
Check that nothing blocks the air inlets and the outlets of the indoor unit and the outdoor unit.
Check that the drain comes smoothly out of the drain hose during COOL or DRY operation. <ul style="list-style-type: none"> • If no drain water is seen, water may be leaking from the indoor unit. Stop operation and consult the service shop if this is the case.

■ Before a long idle period

1. Operate the “FAN only” for several hours on a fine day to dry out the inside.
 - Press “MODE selector button” and select “FAN” operation.
 - Press “ON/OFF button” and start operation.
2. After operation stops, turn off the breaker for the room air conditioner.
3. Clean the air filters and set them again.
4. Take out batteries from the remote controller.

2.12 Troubleshooting

Trouble Shooting

These cases are not troubles.

The following cases are not air conditioner troubles but have some reasons. You may just continue using it.

Case	Explanation
Operation does not start soon. <ul style="list-style-type: none"> When ON/OFF button was pressed soon after operation was stopped. When the mode was reselected. 	<ul style="list-style-type: none"> This is to protect the air conditioner. You should wait for about 3 minutes.
Hot air does not flow out soon after the start of heating operation.	<ul style="list-style-type: none"> The air conditioner is warming up. You should wait for 1 to 4 minutes. (The system is designed to start discharging air only after it has reached a certain temperature.)
The heating operation stops suddenly and a flowing sound is heard.	<ul style="list-style-type: none"> The system is taking away the frost on the outdoor unit. You should wait for about 3 to 10 minutes.
The outdoor unit emits water or steam.	<ul style="list-style-type: none"> ■ HEAT mode <ul style="list-style-type: none"> The frost on the outdoor unit melts into water or steam when the air conditioner is in defrost operation. ■ COOL or DRY mode <ul style="list-style-type: none"> Moisture in the air condenses into water on the cool surface of outdoor unit piping and drips.
Mist comes out of the indoor unit.	<ul style="list-style-type: none"> ■ This happens when the air in the room is cooled into mist by the cold airflow during cooling operation.
The indoor unit gives out odour.	<ul style="list-style-type: none"> ■ This happens when smells of the room, furniture, or cigarettes are absorbed into the unit and discharged with the airflow. (If this happens, we recommend you to have the indoor unit washed by a technician. Consult the service shop where you bought the air conditioner.)
The outdoor fan rotates while the air conditioner is not in operation.	<ul style="list-style-type: none"> ■ After operation is stopped: <ul style="list-style-type: none"> The outdoor fan continues rotating for another 60 seconds for system protection. ■ While the air conditioner is not in operation: <ul style="list-style-type: none"> When the outdoor temperature is very high, the out door fan starts rotating for system protection.
The operation stopped suddenly. (OPERATION lamp is on.)	<ul style="list-style-type: none"> ■ For system protection, the air conditioner may stop operating on a sudden large voltage fluctuation. It automatically resumes operation in about 3 minutes.
No remote controller signals are displayed. The remote controller sensitivity is low. The display is low in contrast or blacked out. The display runs out of control.	<ul style="list-style-type: none"> The batteries are dying and the remote controller is malfunctioning. Replace all the batteries with new size AAA alkaline batteries. For details, refer to "To set the batteries" of this manual. (page 7.) * If the reset button is provided, press the reset button after the batteries are replaced.

Check again.

Please check again before calling a repair person.

Case	Check
The air conditioner does not operate. (OPERATION lamp is off.)	<ul style="list-style-type: none"> • Hasn't a breaker turned OFF or a fuse blown? • Isn't it a power failure? • Are batteries set in the remote controller? • Is the timer setting correct?
Cooling (Heating) effect is poor.	<ul style="list-style-type: none"> • Are the air filters clean? • Is there anything to block the air inlet or the outlet of the indoor and the outdoor units? • Is the temperature setting appropriate? • Are the windows and doors closed? • Are the airflow rate and the air direction set appropriately?
Operation stops suddenly. (OPERATION lamp flashes.)	<ul style="list-style-type: none"> • Are the air filters clean? • Is there anything to block the air inlet or the outlet of the indoor and the outdoor units? <p>Clean the air filters or take all obstacles away and turn the breaker OFF. Then turn it ON again and try operating the air conditioner with the remote controller. If the lamp still flashes, call the service shop where you bought the air conditioner.</p>
An abnormal functioning happens during operation.	<ul style="list-style-type: none"> • The air conditioner may malfunction with lightning or radio waves. Turn the breaker OFF, turn it ON again and try operating the air conditioner with the remote controller.

Call the service shop immediately.



WARNING

- When an abnormality (such as a burning smell) occurs, stop operation and turn the breaker OFF.
Continued operation in an abnormal condition may result in troubles, electric shocks or fire.
Consult the service shop where you bought the air conditioner.
- Do not attempt to repair or modify the air conditioner by yourself.
Incorrect work may result in electric shocks or fire.
Consult the service shop where you bought the air conditioner.

If one of the following symptoms takes place, call the service shop immediately.

- **The power cord is abnormally hot or damaged.**
- **An abnormal sound is heard during operation.**
- **The safety breaker, a fuse, or the earth leakage breaker cuts off the operation frequently.**
- **A switch or a button often fails to work properly.**
- **There is a burning smell.**
- **Water leaks from the indoor unit.**

Turn the breaker OFF and call the service shop.

- | | |
|--|--|
| <ul style="list-style-type: none"> ■ After a power failure
The air conditioner automatically resumes operation in about 3 minutes. You should just wait for a while. | <ul style="list-style-type: none"> ■ Lightning
If lightning may strike the neighbouring area, stop operation and turn the breaker OFF for system protection. |
|--|--|

Disposal requirements

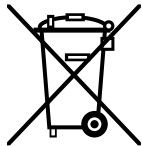

Your air conditioning product is marked with this symbol. This means that electrical and electronic products shall not be mixed with unsorted household waste.

Do not try to dismantle the system yourself: the dismantling of the air conditioning system, treatment of the refrigerant, of oil and of other parts must be done by a qualified installer in accordance with relevant local and national legislation.

Air conditioners must be treated at a specialized treatment facility for re-use, recycling and recovery. By ensuring this product is disposed of correctly, you will help to prevent potential negative consequences for the environment and human health. Please contact the installer or local authority for more information.

Batteries must be removed from the remote controller and disposed of separately in accordance with relevant local and national legislation.

We recommend periodical maintenance.

In certain operating conditions, the inside of the air conditioner may get foul after several seasons of use, resulting in poor performance. It is recommended to have periodical maintenance by a specialist aside from regular cleaning by the user. For specialist maintenance, contact the service shop where you bought the air conditioner. The maintenance cost must be born by the user.

Important information regarding the refrigerant used.

This product contains fluorinated greenhouse gases covered by the Kyoto Protocol.

Refrigerant type: **R410A**

GWP⁽¹⁾ value: **1975**

⁽¹⁾ GWP = global warming potential

Periodical inspections for refrigerant leaks may be required depending on European or local legislation. Please contact your local dealer for more information.

Part 6

Service Diagnosis

1. Caution for Diagnosis.....	52
2. Problem Symptoms and Measures	53
3. Service Check Function	54
4. Troubleshooting	55
4.1 Error Codes and Description	55
4.2 Indoor Unit PCB Abnormality	56
4.3 Freeze-up Protection Control, High Pressure Control or Indoor Heat Exchanger Thermistor Abnormality	57
4.4 Fan Motor or Related Abnormality (AC motor).....	59
4.5 Thermistor or Related Abnormality.....	60
4.6 High Pressure Control in Cooling or Outdoor Heat Exchanger Thermistor Abnormality	62
4.7 Hardware Error (Tact Switch Pin Short)	64
4.8 Insufficient Gas.....	65
5. Check.....	67
5.1 Thermistor Resistance Check	67
5.2 Installation Condition Check.....	68
5.3 Outdoor Unit Fan System Check.....	69
5.4 Hall IC Check	69

1. Caution for Diagnosis

The operation lamp flashes when any of the following errors is detected.

1. When a protection device of the indoor or outdoor unit is activated or when the thermistor malfunctions, disabling equipment operation.
 2. When a signal transmission error occurs between the indoor and outdoor units.
- In either case, conduct the diagnostic procedure described in the following pages.

Location of Operation Lamp

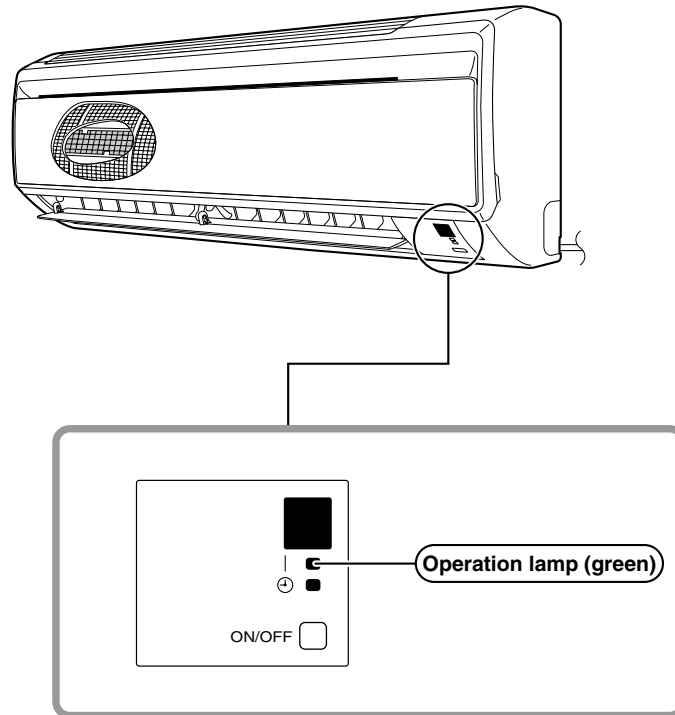

(R8499)

2. Problem Symptoms and Measures

Problem	Check	Solution	Reference Page
None of the units operates.	Check the power supply.	Check to make sure that the rated voltage is supplied.	—
	Check the type of the indoor units.	Check to make sure that the indoor unit type is compatible with the outdoor unit.	—
	Check the outdoor air temperature.	Heating operation cannot be used when the outdoor air temperature is 24°C or higher, and cooling operation cannot be used when the outdoor air temperature is below 10°C.	—
	Diagnosis with remote controller indication	—	55
	Check the remote controller addresses.	Check to make sure that address settings for the remote controller and indoor unit are correct.	—
Operation sometimes stops.	Check the power supply.	A power failure of 2 to 10 cycles can stop air conditioner operation. (Operation lamp OFF)	—
	Check the outdoor air temperature.	Heating operation cannot be used when the outdoor air temperature is 24°C or higher, and cooling operation cannot be used when the outdoor air temperature is below 10°C .	—
	Diagnosis with remote controller indication	—	55
Equipment operates but does not cool, or does not heat.	Check for wiring and piping errors in the indoor and outdoor units connection wires and pipes.	Conduct the wiring/piping error check described on the product diagnosis nameplate.	—
	Check for thermistor detection errors.	Check to make sure that the main unit's thermistor has not dismounted from the pipe holder.	—
	Diagnosis with remote controller indication	—	55
Large operating noise and vibrations	Check the output voltage of the power transistor.	—	—
	Check the power transistor.	—	—
	Check the installation condition.	Check to make sure that the required spaces for installation (specified in the Engineering Data Book, etc.) are provided.	—

3. Service Check Function

The temperature display sections on the main unit indicate corresponding codes.

Check Method

1. When the ON timer or OFF timer cancel button is held down for 5 seconds, a "00" indication flashes on the temperature display section.

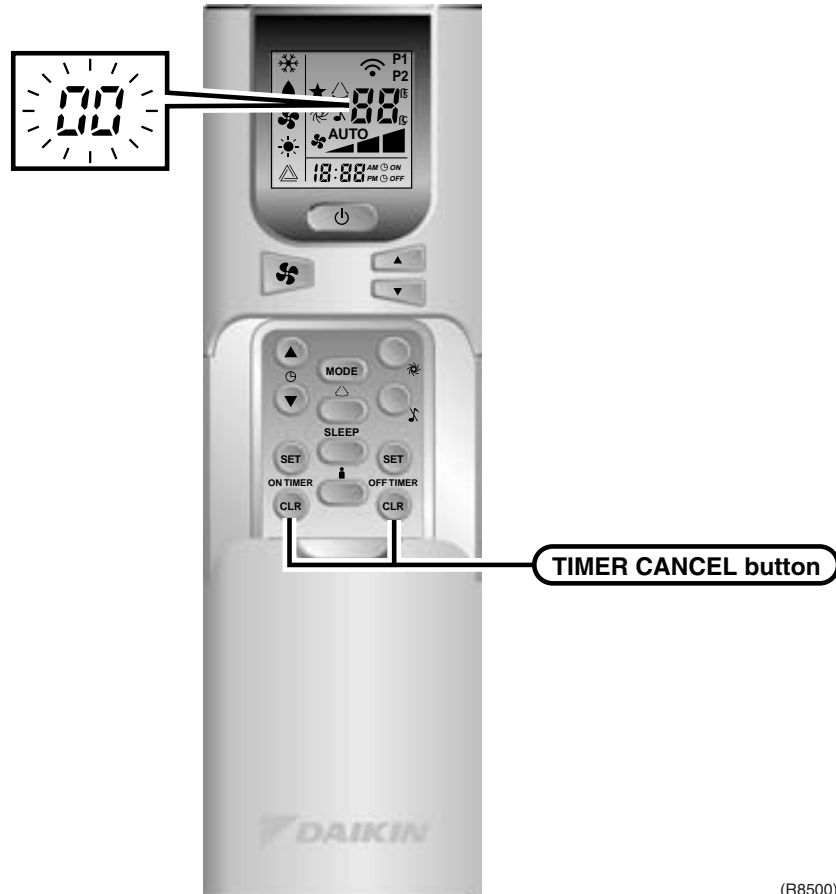

(R8500)

2. Press either ON timer or OFF timer cancel button repeatedly until a long beep is produced.
 - The code indication changes in the sequence shown below, and notifies with a long beep.

No.	Code	No.	Code	No.	Code
1	00	13	07	25	0A
2	04	14	0B	26	0B
3	05	15	0C	27	0C
4	06	16	0D	28	0D
5	0E	17	0E	29	0E
6	0F	18	0F	30	0F
7	10	19	10	31	10
8	11	20	11	32	11
9	12	21	12	33	12
10	13	22	13	34	13
11	14	23	14	35	14
12	15	24	15	36	15



Note:

1. A short beep and two consecutive beeps indicate non-corresponding codes.
2. To cancel the code display, hold the ON timer or OFF timer cancel button down for 5 seconds. The code display also cancels itself if the button is not pressed for 1 minute.

4. Troubleshooting

4.1 Error Codes and Description

	Code	Description	Reference Page
System	00	Normal	—
	U0	Insufficient gas	65
	UR	Hardware error (tact switch pin short)	64
Indoor Unit	P1	Indoor unit PCB abnormality	56
	P5	Freeze-up protection control, high pressure control or indoor heat exchanger thermistor abnormality	57
	P6	Fan motor or related abnormality (AC motor)	59
	C4	Heat exchanger thermistor abnormality	60
	C9	Room temperature thermistor abnormality	60
Outdoor Unit	F6	High pressure control in cooling or outdoor heat exchanger thermistor abnormality	62
	U6	Heat exchanger thermistor or related abnormality	64

★: Displayed only when system-down occurs.

4.2 Indoor Unit PCB Abnormality

Remote Controller Display	81
Method of Malfunction Detection	Evaluation of zero-cross detection of power supply by indoor unit.
Malfunction Decision Conditions	When there is no zero-cross detection in approximately 1.25 continuous seconds.
Supposed Causes	<ul style="list-style-type: none"> ■ Faulty indoor unit PCB ■ Faulty connector connection

Troubleshooting

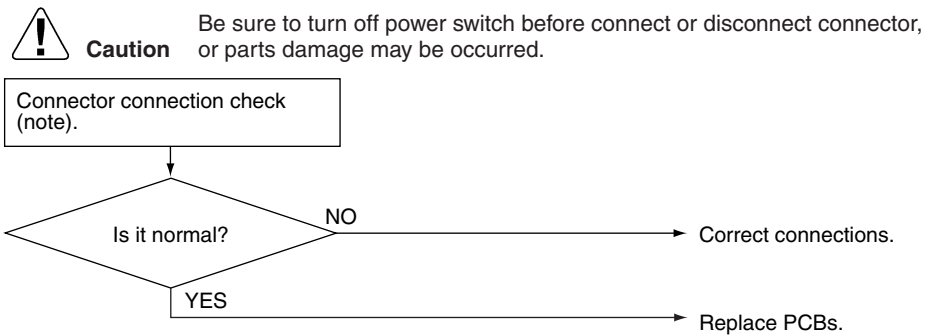

(R7130)

 **Note:** Connector Nos. vary depending on models.

Model Type	Connector No.
All indoor units	Terminal strip~Control PCB

4.3 Freeze-up Protection Control, High Pressure Control or Indoor Heat Exchanger Thermistor Abnormality

Remote
Controller
Display

AS

Method of
Malfunction
Detection

- High pressure control
During heating operations, the temperature detected by the indoor heat exchanger thermistor is used for the high pressure control (stop, outdoor fan stop, etc.)
- Freeze-up protection control (operation halt) is activated during cooling operation according to the temperature detected by the indoor unit heat exchanger thermistor.
The temperature detected by the indoor heat exchanger thermistor is used to determine thermistor error.

Malfunction
Decision
Conditions

- High pressure control
During heating operations, the temperature detected by the indoor heat exchanger thermistor is above 68°C.
- Freeze-up protection
When the indoor unit heat exchanger temperature is below 1°C during cooling operation.
- Indoor Heat Exchanger Thermistor Abnormality
When the input voltage of thermistor during the compressor is operating is 4.96V or more.

Supposed
Causes

- Operation halt due to clogged air filter of the indoor unit.
- Operation halt due to dust accumulation on the indoor unit heat exchanger.
- Operation halt due to short-circuit.
- Detection error due to faulty indoor unit heat exchanger thermistor.
- Detection error due to faulty indoor unit PCB.
- Stop valve closed.

Troubleshooting



Check No.06
Refer to P.67



Caution Be sure to turn off power switch before connect or disconnect connector, or parts damage may be occurred.

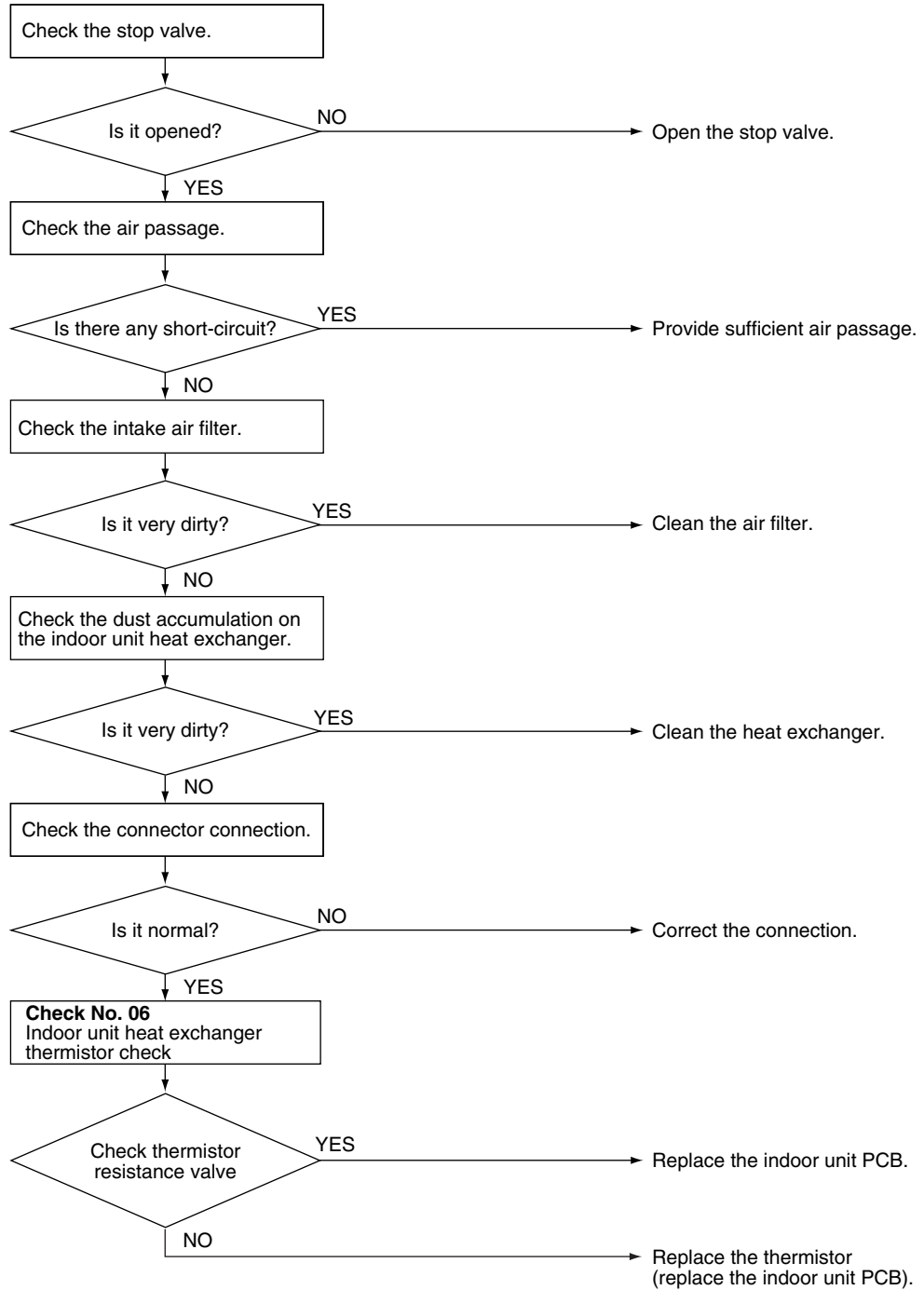

(R8503)

4.4 Fan Motor or Related Abnormality (AC motor)

Remote
Controller
Display



Method of
Malfunction
Detection

The rotation speed detected by the Hall IC during fan motor operation is used to determine abnormal fan motor operation.

Malfunction
Decision
Conditions

When the detected rotation speed is less than 50% of each tap under maximum fan motor rotation demand.

Supposed
Causes

- Operation halt due to short circuit inside the fan motor winding.
- Operation halt due to breaking of wire inside the fan motor.
- Operation halt due to breaking of the fan motor lead wires.
- Operation halt due to faulty capacitor of the fan motor.
- Detection error due to faulty indoor unit PCB.

Troubleshooting



Check No.16
Refer to P.69



Caution Be sure to turn off power switch before connect or disconnect connector, or parts damage may be occurred.

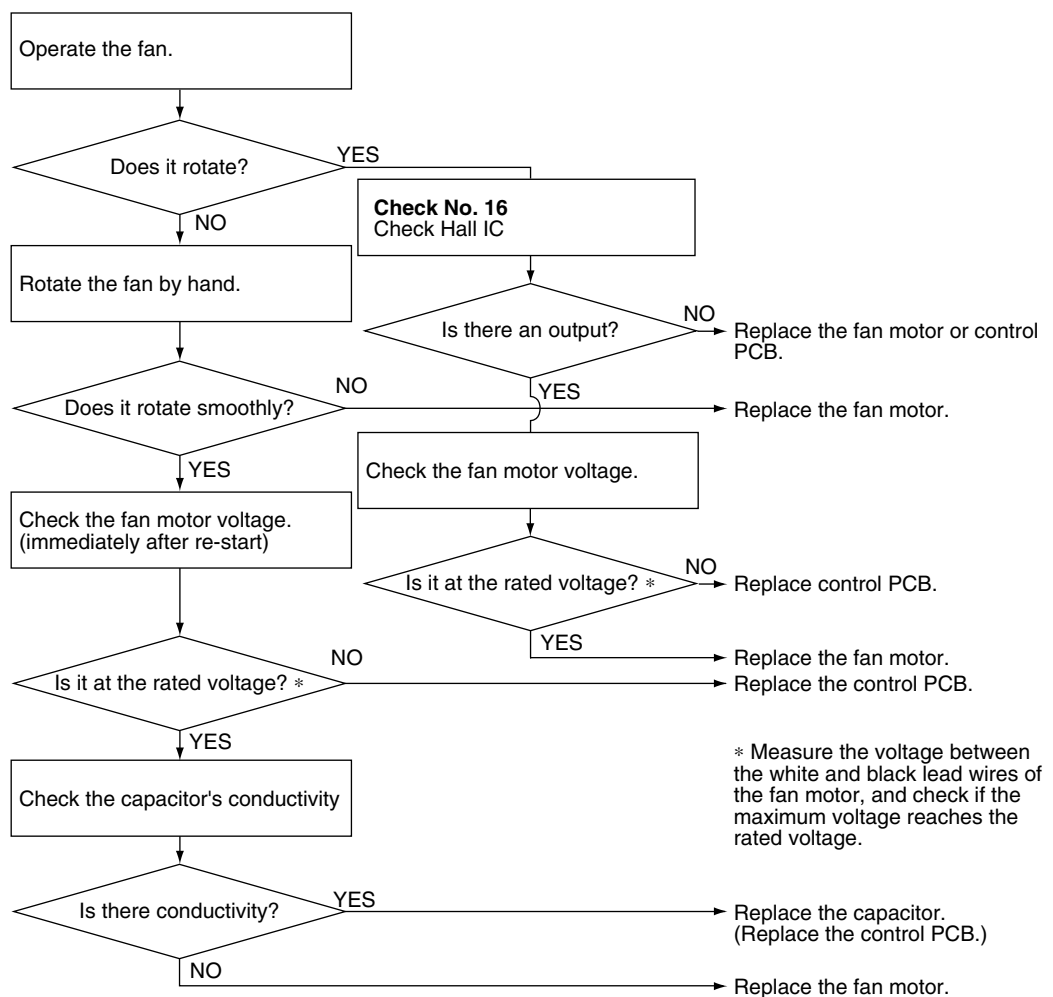

(R8504)

4.5 Thermistor or Related Abnormality

4.5.1 Heat Exchanger Thermistor

Remote
Controller
Display

Ⓞ4, Ⓞ5

Method of
Malfunction
Detection

The temperatures detected by the indoor and outdoor heat exchanger thermistors are used to determine thermistor errors.

Malfunction
Decision
Conditions

When the indoor and outdoor heat exchanger thermistor input is 0.04 V or less during compressor operation*.

* (Reference)

Indoor and outdoor heat exchanger thermistor: 1150kΩ or more

Supposed
Causes

- Faulty connector connection
- Faulty thermistor
- Faulty PCB

Troubleshooting

Check No.06
Refer to P.67



Caution

Be sure to turn off power switch before connect or disconnect connector, or parts damage may be occurred.

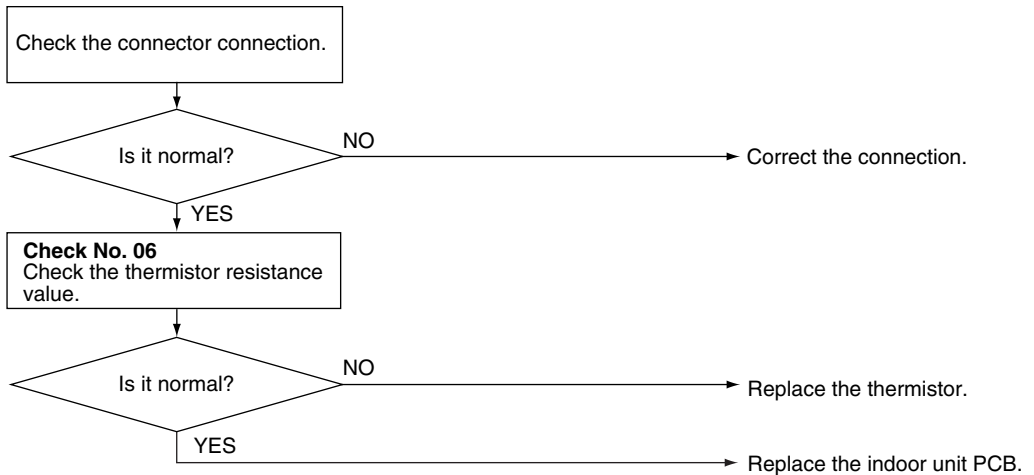

(R8513)

Ⓞ4 : Indoor heat exchanger thermistor

Ⓞ5 : Outdoor heat exchanger thermistor

4.5.2 Room Temperature Thermistor

Remote
Controller
Display

09

Method of
Malfunction
Detection

The temperatures detected by the room temperature thermistor is used to determine thermistor error.

Malfunction
Decision
Conditions

When the room temperature thermistor input is more than 4.96 V or more, or 0.04 V or less during compressor operation*.

* (Reference)

Room temperature thermistor: 30Ω or less, or 490kΩ or more.

Supposed
Causes

- Faulty thermistor
- Faulty PCB

Troubleshooting



Check No.06
Refer to P.67



Caution

Be sure to turn off power switch before connect or disconnect connector, or parts damage may be occurred.

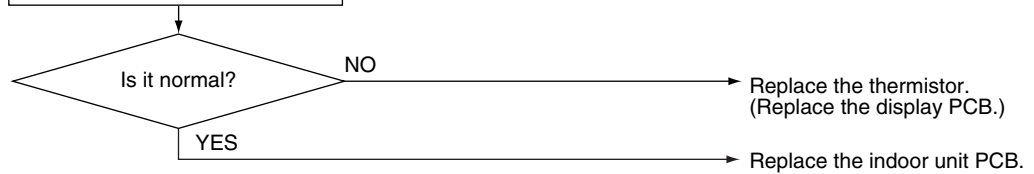
Check No. 06
Check the thermistor resistance value.



(R8505)

4.6 High Pressure Control in Cooling or Outdoor Heat Exchanger Thermistor Abnormality

Remote
Controller
Display



Method of
Malfunction
Detection

High-pressure control (stop) is activated in the cooling mode if the temperature being sensed by the heat exchanger thermistor exceeds the limit.
The temperature detected by the outdoor heat exchanger thermistor is used to determine the abnormal thermistor.

Malfunction
Decision
Conditions

- Activated when the temperature being sensed by the heat exchanger thermistor rises above 68°C.
- Deactivated when the temperature drops below 50°C.
- When the outdoor heat exchanger thermistor input is 4.96 V or more during compressor operation.

Supposed
Causes

- The installation space is not large enough.
- Faulty outdoor heat exchanger thermistor
- Stop valve closed
- Dirty heat exchanger

Troubleshooting

 **Check No.06**
Refer to P.67

 **Check No.07**
Refer to P.68

 **Check No.09**
Refer to P.69

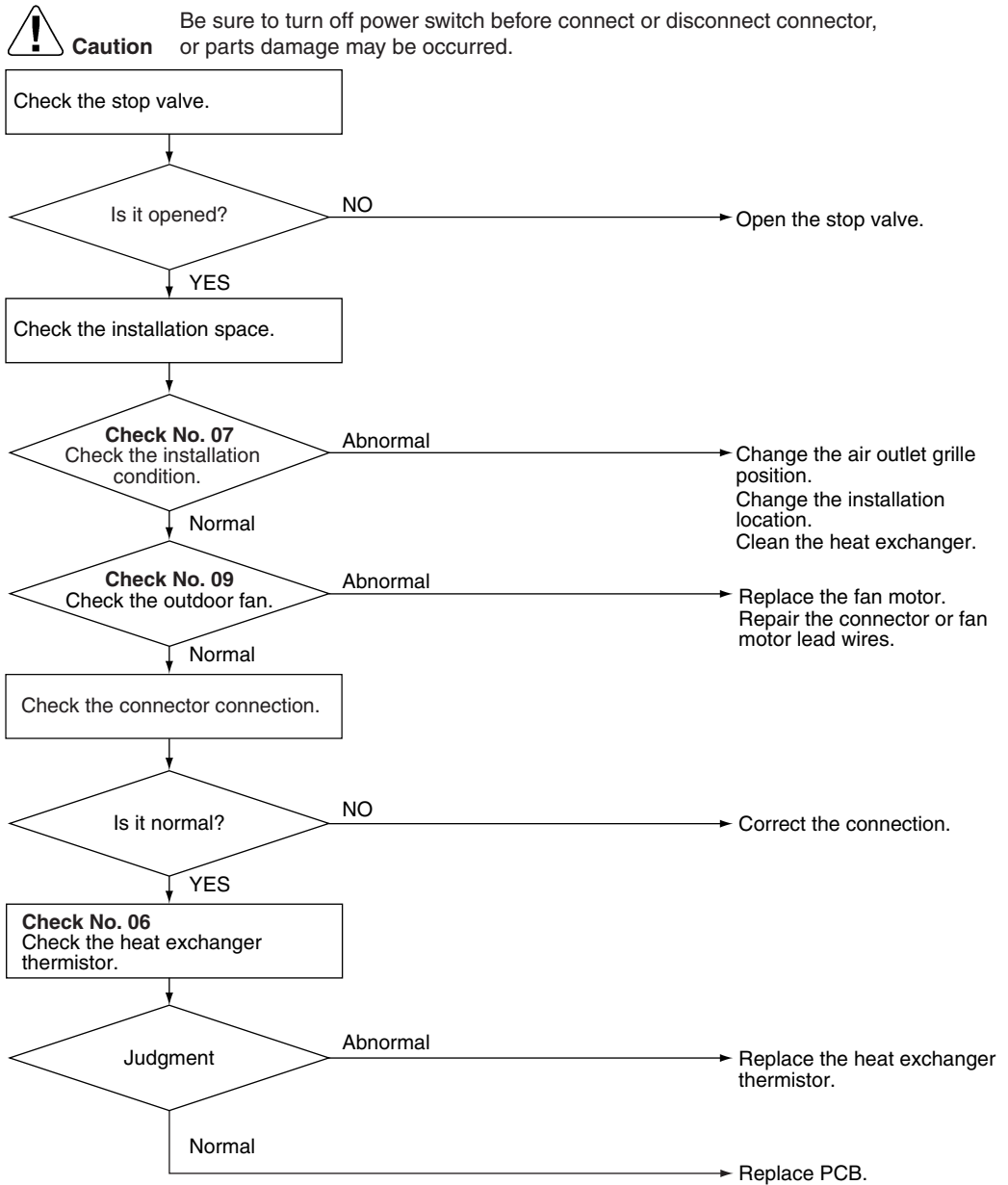

(R8506)

4.7 Hardware Error (Tact Switch Pin Short)

Remote
Controller
Display

UR

Method of
Malfunction
Detection

The supply power is detected for its requirement (different from pair type and multi type) by the indoor / outdoor transmission signal.

Malfunction
Decision
Conditions

The pair type and multi type are interconnected.

Supposed
Causes

- Wrong models interconnected
- Wrong indoor unit PCB mounted
- Indoor unit PCB defective
- Wrong outdoor unit PCB mounted or defective

Troubleshooting

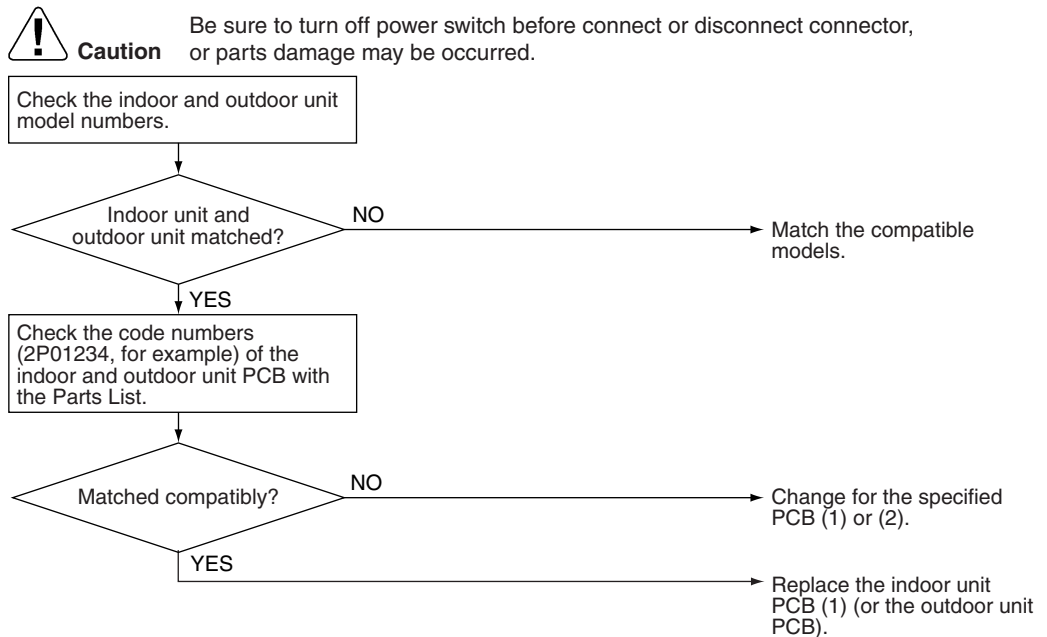

(R7342)

4.8 Insufficient Gas

**Remote
Controller
Display**

**Method of
Malfunction
Detection**

A gas shortage is detected by checking the indoor unit heat exchanger temperature.

**Malfunction
Decision
Conditions**

When the compressor operates for 30 min. with the indoor heat exchanger temperature is Δ °C and then, check for 5 more min. before determining insufficient gas and system down.

**Supposed
Causes**

- Refrigerant shortage (refrigerant leakage)
- Poor compression performance of compressor
- Indoor heat exchanger thermistor disconnected
- Stop valve closed

Troubleshooting

Check No.06
Refer to P.67



Caution Be sure to turn off power switch before connect or disconnect connector, or parts damage may be occurred.

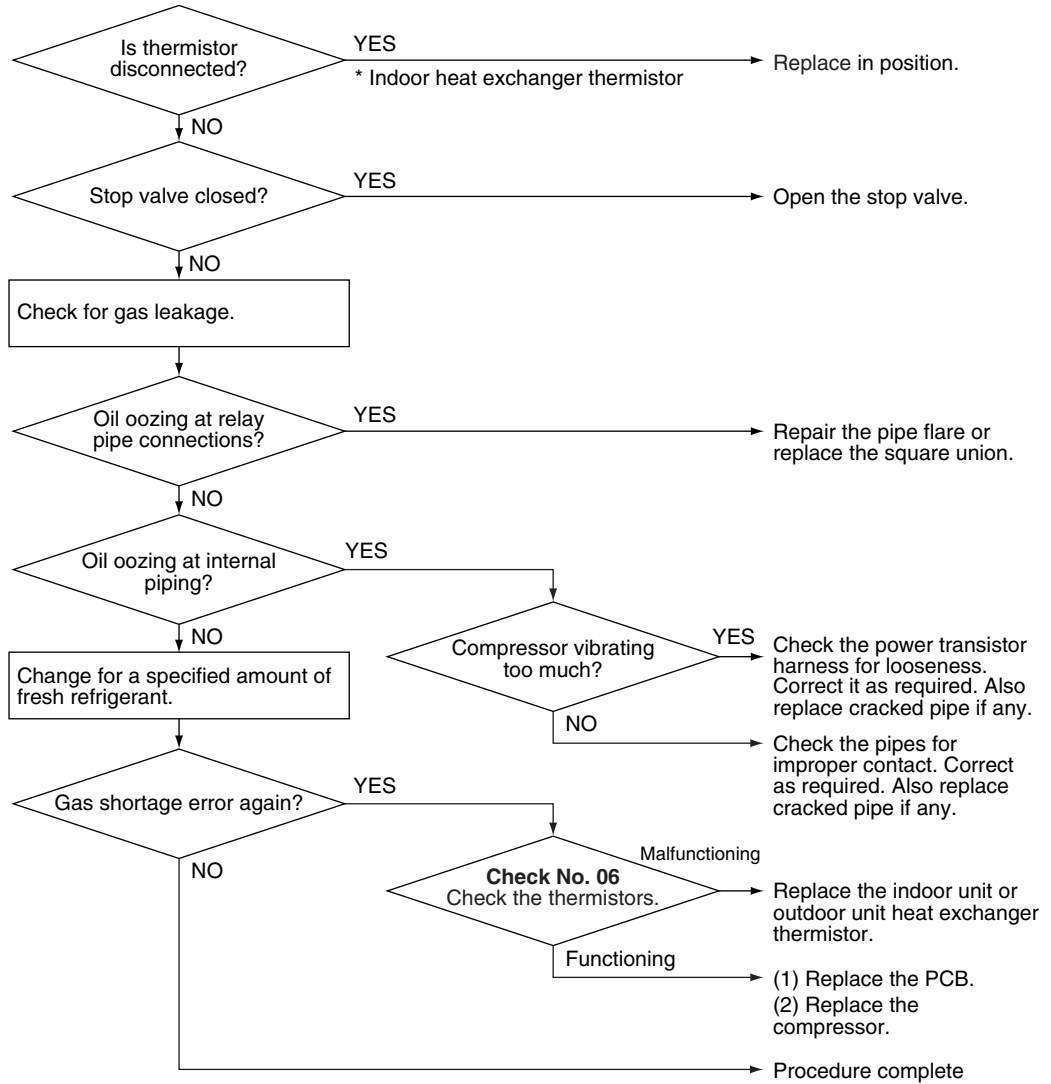

(R8507)

5. Check

5.1 Thermistor Resistance Check

Check No.06

Remove the connectors of the thermistors on the PCB, and measure the resistance of each thermistor using tester.

The relationship between normal temperature and resistance is shown in the graph and the table below.

Temperature (°C)	R25°C=10kΩ B=3450 Thermistor (kΩ)
-20	72.7
-15	56.6
-10	44.5
-5	35.2
0	28.0
5	22.5
10	18.2
15	14.8
20	12.1
25	10.0
30	8.3
35	6.9
40	5.8
45	4.9
50	4.1

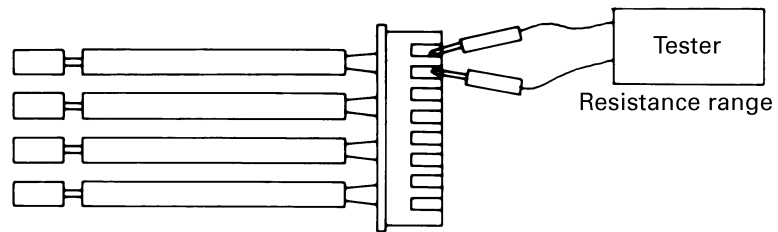

(R25=10kΩ、B=3450)

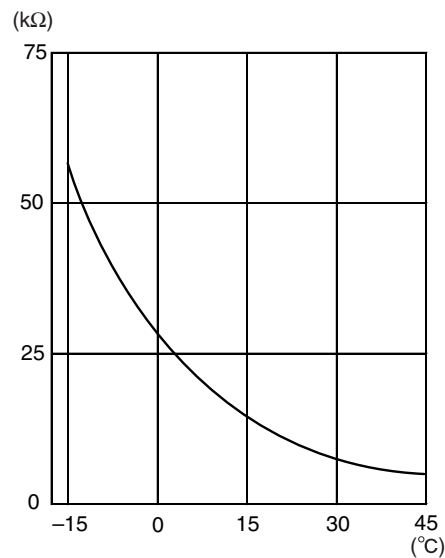

(R4744)

5.2 Installation Condition Check

Check No.07

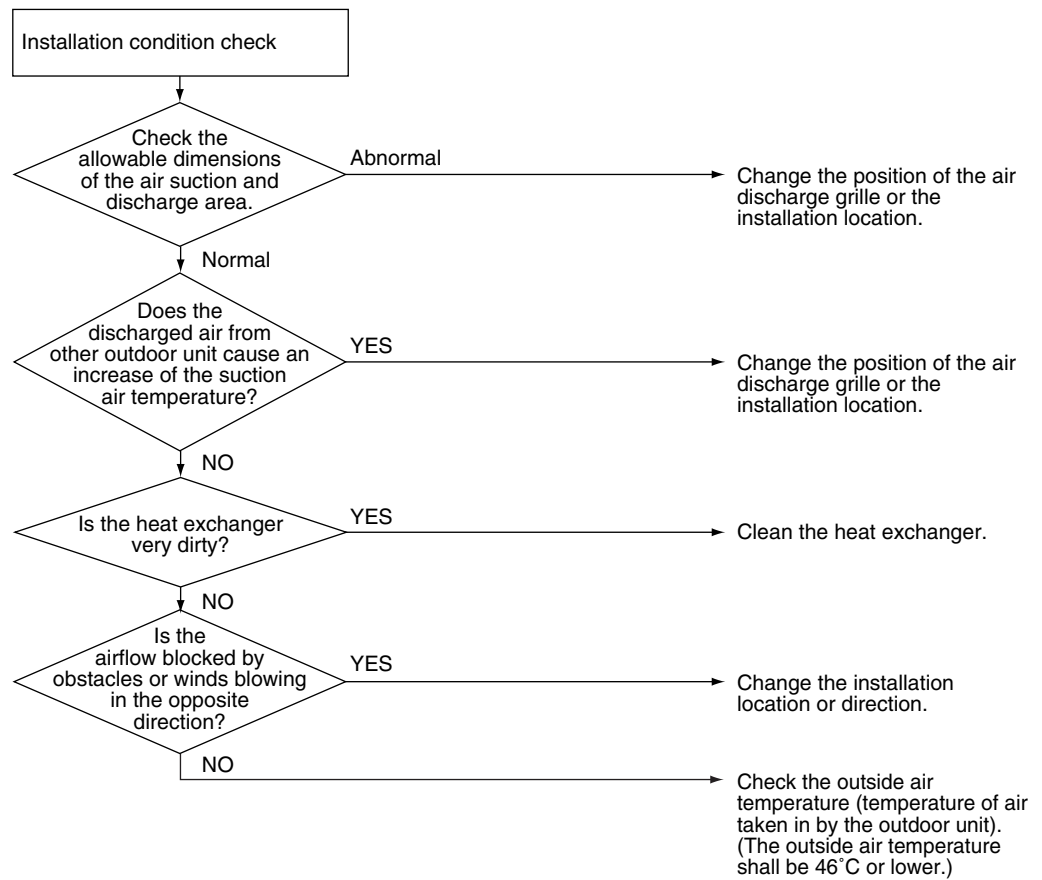

(R8508)

5.3 Outdoor Unit Fan System Check

Check No.09

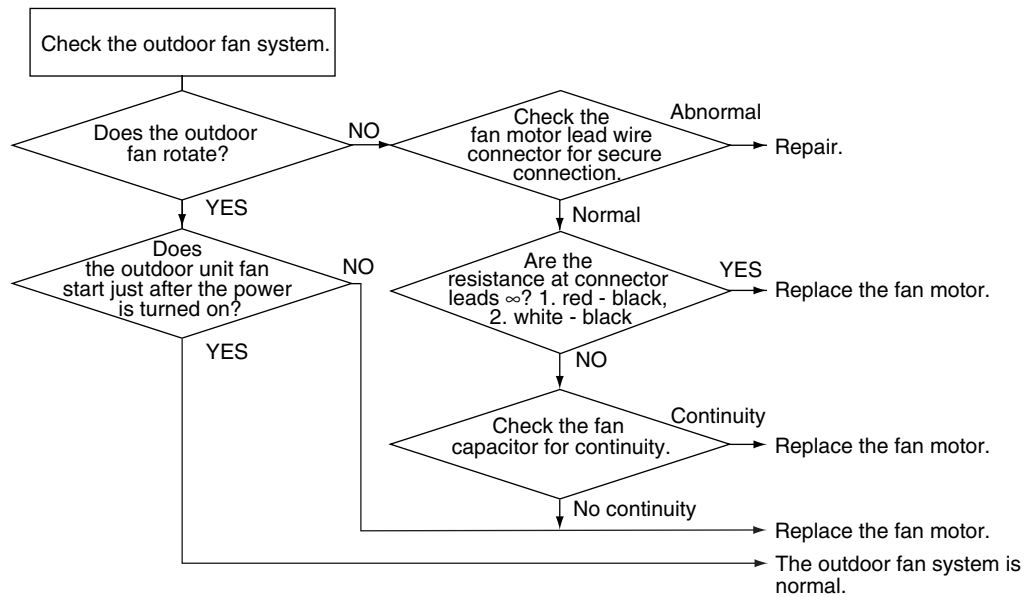

(R8502)

5.4 Hall IC Check

Check No.16

1. Check the connector connection.
2. With the power ON, operation OFF, and the connector connected, check the following.
 - *Output voltage of about 5 V between pins 1 and 3.
 - *Generation of 3 pulses between pins 2 and 3 when the fan motor is operating.

Failure of (1) → faulty PCB → Replace the PCB.

Failure of (2) → faulty Hall IC → Replace the fan motor.

Both (1) and (2) result → Replace the PCB.

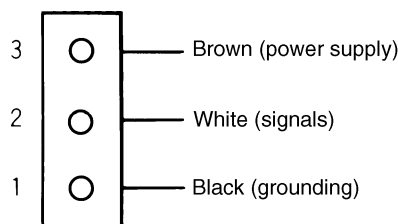

(R8501)

Part 7

Removal Procedure

1. Indoor Unit.....	72
1.1 Removal of Air Filter.....	72
1.2 Removal of Front Grille	75
1.3 Removal of Horizontal Blades / Vertical Blades	78
1.4 Removal of Electrical Parts Box / PCB / Swing Motor.....	80
1.5 Removal of Heat Exchanger	86
1.6 Install of Drain Plug	89
1.7 Removal of Fan Rotor / Fan Motor	90
2. Outdoor Unit.....	94
2.1 Removal of Panels	94
2.2 Removal of Bellmouth and Left Side Plate.....	96
2.3 Removal of Electrical Device Mounting Plate.....	97
2.4 Removal of Propeller Fan and Fan Motor	98
2.5 Removal of Sound Blanket.....	99
2.6 Removal of Partition Plate.....	101
2.7 Removal of Compressor.....	103

Part 8 Others

1. Others	106
1.1 Trial Operation and Testing	106
1.2 Pump Down Operation	106
1.3 Jumper Settings	107

1. Others

1.1 Trial Operation and Testing

1. Measure the supply voltage and make sure that it falls in the specified range.
2. Trial operation should be carried out in either cooling or heating mode.
In cooling mode, select the lowest programmable temperature; in heating mode, select the highest programmable temperature.
 - ◆ Trial operation may be disabled in either mode depending on the room temperature.
 - ◆ After trial operation is complete, set the temperature to a normal level (26°C to 28°C in cooling mode, 20°C to 24°C in heating mode).
 - ◆ For protection, the system disables restart operation for 3 to 4 minutes after it is turned off.
3. Carry out the test operation in accordance with the Operation Manual to ensure that all functions and parts, such as louver movement, are working properly.
 - ◆ The air conditioner requires a small amount of power in its standby mode. If the system is not to be used for some time after installation, shut off the circuit breaker to eliminate unnecessary power consumption.
 - ◆ If the circuit breaker trips to shut off the power to the air conditioner, the system will restore the original operation mode when the circuit breaker is opened again.

1.2 Pump Down Operation

In order to protect the environment, be sure to pump down when relocating or disposing of the unit

1. Remove the valve lid from liquid shut-off valve and gas shut-off valve.
2. Set the unit to the lowest programmable temperature and perform cooling operation.
Cooling operation may be unavailable depending on the room temperature.
If this is the case, warm the indoor room temperature sensor with a hair dryer or similar device and then perform cooling operation.
3. After five to ten minutes, close the liquid shut-off valve with a hexagonal wrench.
4. After two to three minutes, close the gas shut-off valve and stop cooling operation.

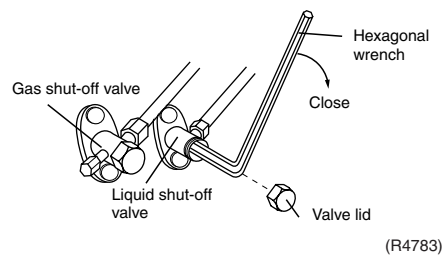

1.3 Jumper Settings

1.3.1 When Two Units are Installed in One Room

- **How to set the different addresses.**
- When two indoor units are installed in one room, the two wireless remote controllers can be set for different addresses.

PCB in the indoor unit

- Remove the front panel.
- Remove the electrical parts box (1-screw).
- Slide the metallic cover to remove it. (4-claws on the electrical parts box.)
- Cut the jumper **JA** on PCB.

Wireless remote controller

- Cut the jumper **J4**.

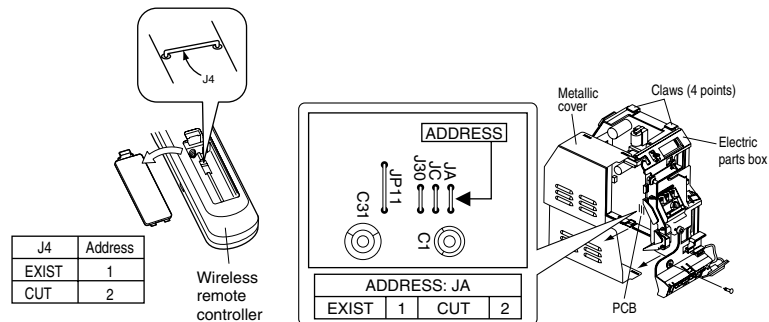

(R4758)

1.3.2 Jumper Setting

Jumper (On indoor control PCB)	Function	When connected (factory set)	When cut
JC	Power failure recovery function	Auto re-start	Unit does not resume operation after recovering from a power failure. Timer ON-OFF settings are cleared.

Part 9

Appendix

1. Piping Diagrams.....	110
1.1 Indoor Units.....	110
1.2 Outdoor Units.....	111
2. Wiring Diagrams.....	113
2.1 Indoor Units.....	113
2.2 Outdoor Units.....	113

1. Piping Diagrams

1.1 Indoor Units

FTYN25GXV1B, FTY25GXV1

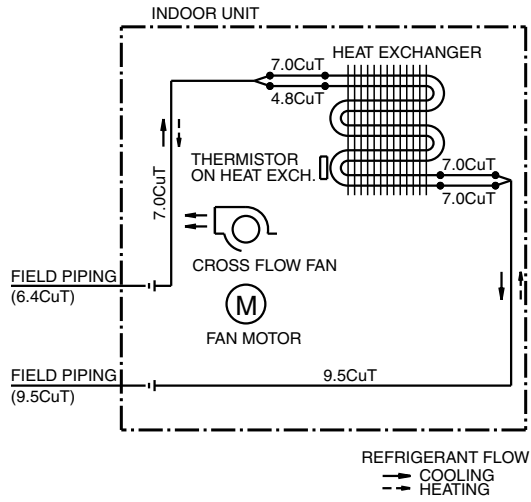

4D059933

FTYN35GXV1B, FTY35GXV1

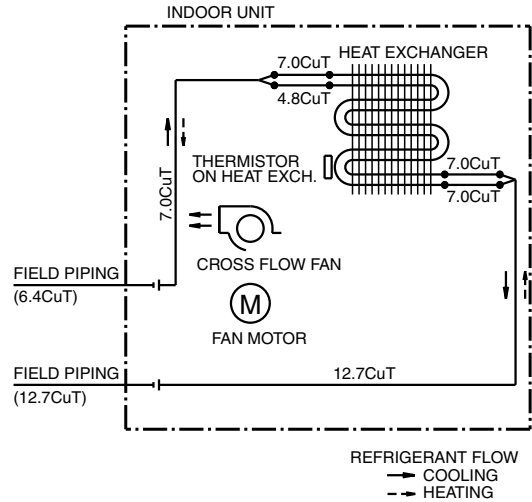

4D059934

1.2 Outdoor Units

RYN25GXV1B

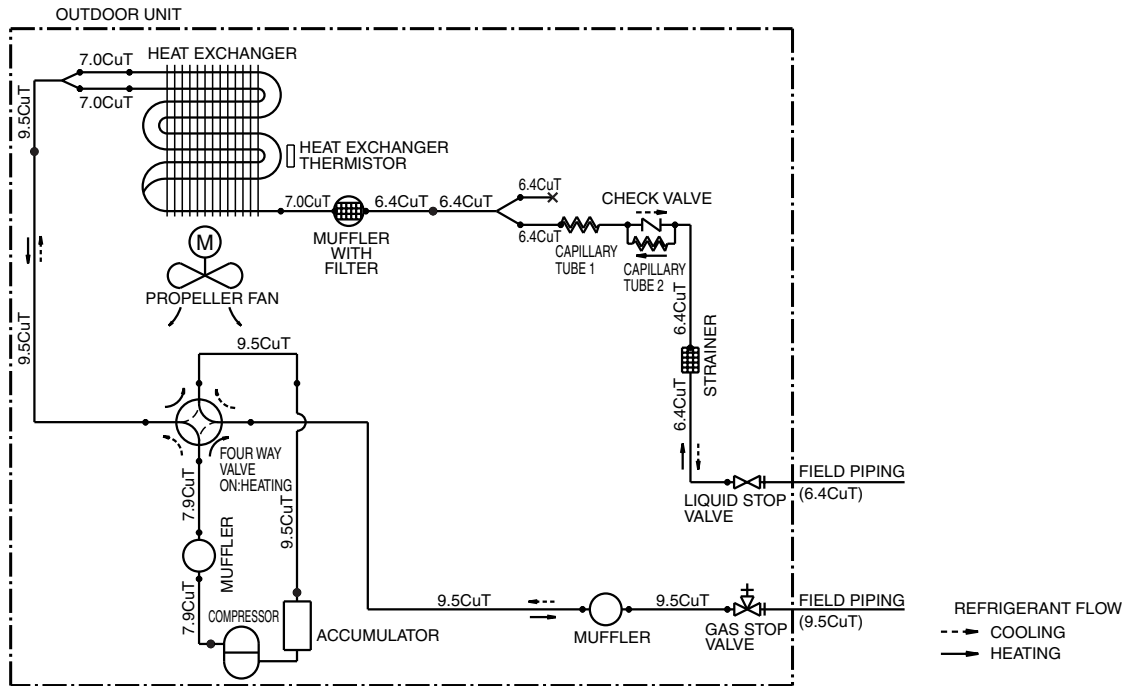

3D060002

RYN35GXV1B

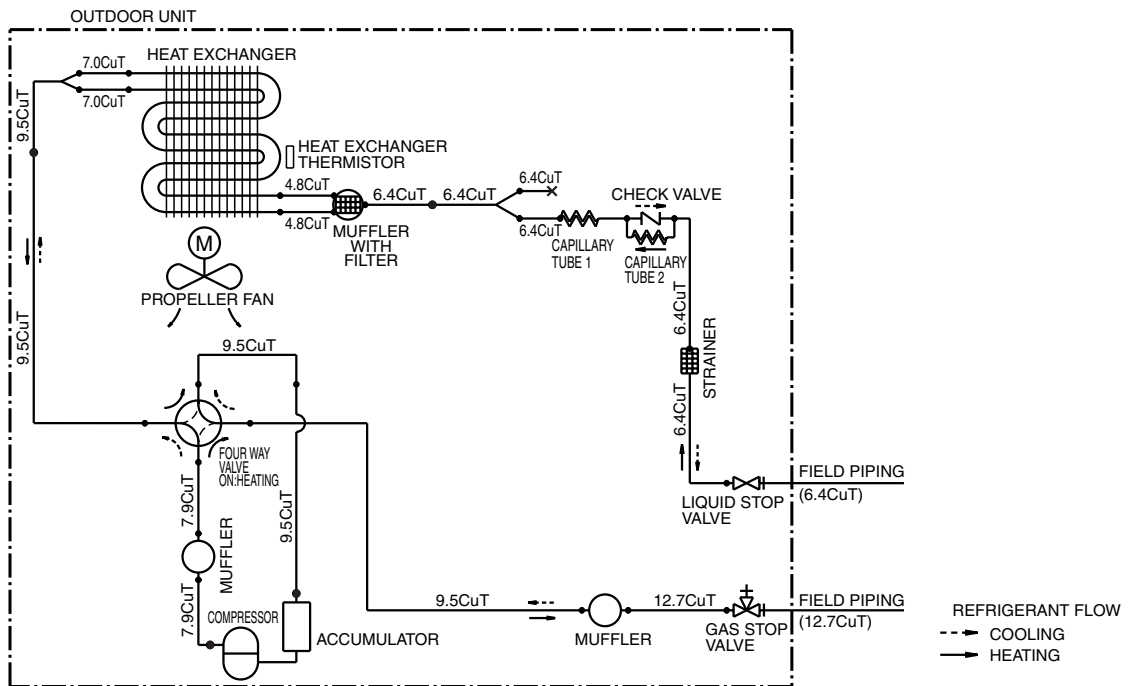

3D060001

RY25GXV1

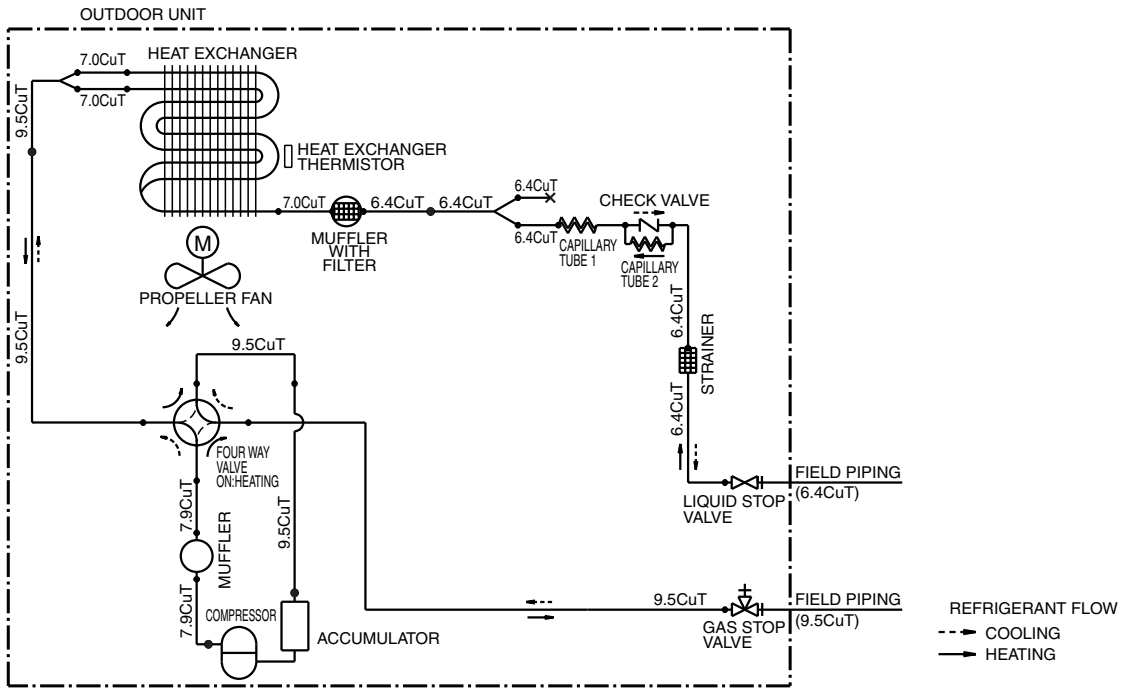

3D060140

RY35GXV1

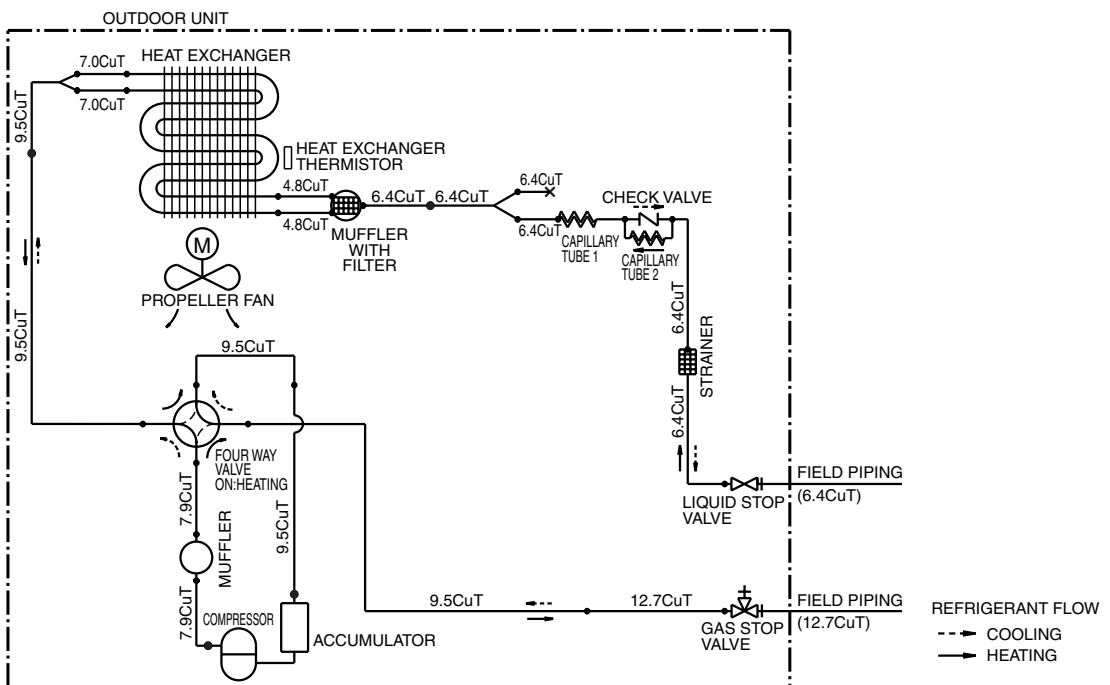

3D060141

2. Wiring Diagrams

2.1 Indoor Units

FTYN25GXV1B, FTYN35GXV1B, FTY25GXV1, FTY35GXV1

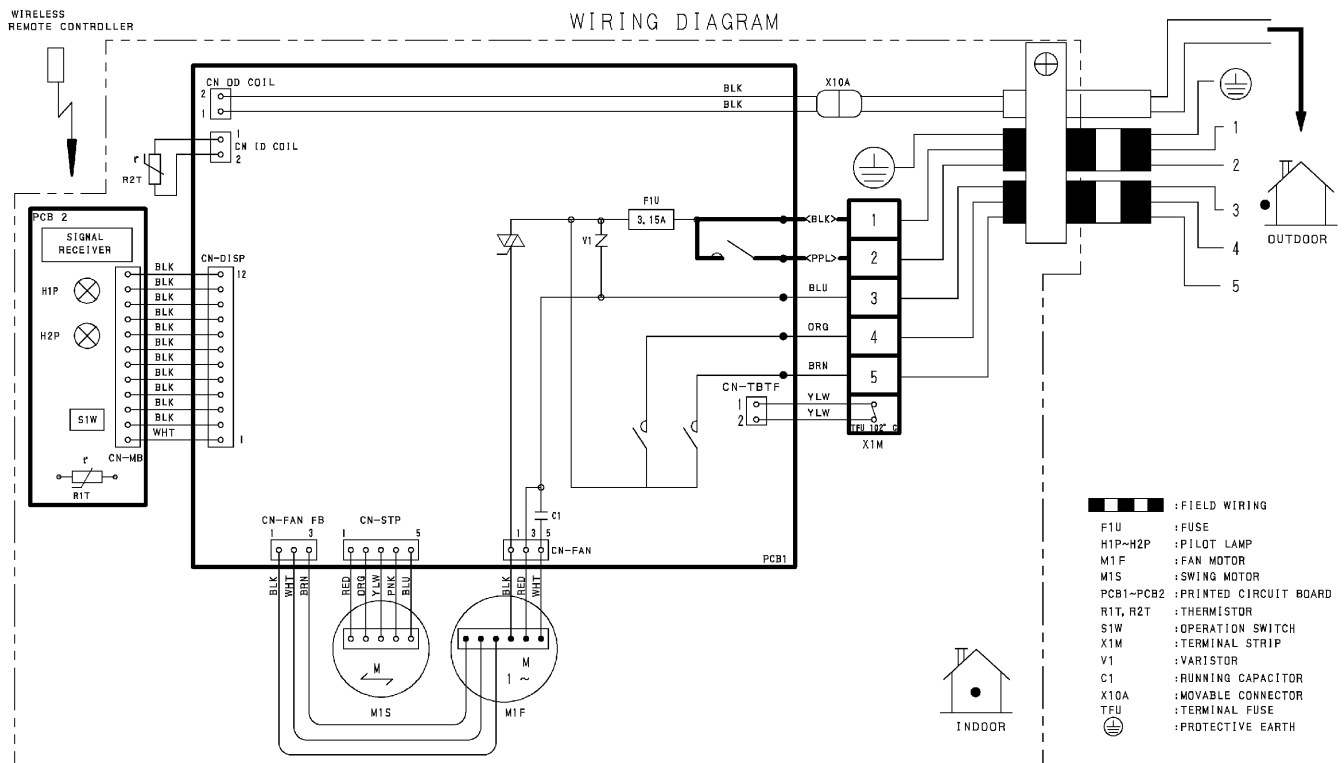

3D060223

2.2 Outdoor Units

RYN25GXV1B, RYN35GXV1B, RY25GXV1, RY35GXV1

OUTDOOR UNIT WIRING DIAGRAM

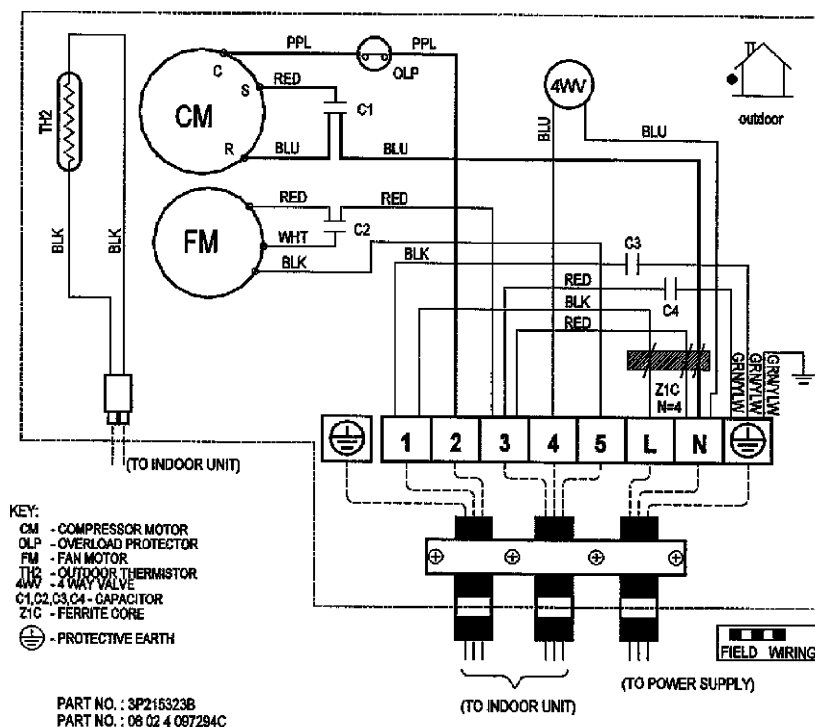

3D060145

Index

Numerics

00	63
3-minutes standby	27, 29

A

A1	64
A5	65
A6	67
address setting jumper	16
adjusting the air flow direction	45
air filter	27, 78
air flow rate control	21
AUTO • DRY • COOL • HEAT • FAN operation	43
automatic operation	23
auto-restart function	27, 113
auto-swing	20

B

bellmouth	102
-----------------	-----

C

C4	68
C9	68
care and cleaning	49
caution for diagnosis	58
check	73
check	
Hall IC check	75
installation condition check	74
outdoor unit fan system check	75
thermistor resistance check	73
check No.06	73
check No.07	74
check No.09	75
check No.16	75
compressor	109
compressor protection function	29
connectors	16
control PCB	17, 64, 91

D

defrost control	31
diagnosis mode	61
drain hose	92, 95
drain plug	95

E

electrical device mounting plate	103
electrical parts box	86
error codes	
00	63
A1	64
A5	65
A6	67
C4	68

C9	68
F6	69
J6	71

F

F6	69
fan motor	86, 96, 104
fan off delay	29
fan rotor	96
fan speed control	21
four way valve switching	29
freeze-up protection control	29, 65
front grille	81
front panel	79
front plate	101
FU1	16
functions	2
fuse	16

G

gas piping	92
------------------	----

H

H1	16
H2	16
H3	16
H4	16
H5	16
Hall IC	21, 67
Hall IC check	75
heat exchanger	92
heat exchanger thermistor	86
heating peak-cut control	30
high pressure control	65
high pressure control in cooling	69
horizontal blade	84
hot start function	27

I

indoor heat exchanger thermistor	28, 68
indoor unit PCB abnormality	64
installation condition check	74
instructions	35

J

J4	113
J6	71
JA	16, 113
JC	16, 113
jumper settings	113

L

LED A	16
LED1	16
LED2	16

left side plate	101, 102	switch box	103
liquid compression protection function	30	T	
liquid piping	92	terminal strip	64, 87
M		thermistor	
mold proof air filter	27	function	28
N		heat exchanger thermistor	86
names of parts	37	indoor heat exchanger thermistor	28, 68
night set mode	25	outdoor heat exchanger thermistor	28, 72
O		room temperature thermistor	68
ON/OFF button on indoor unit	27	thermistor or related abnormality (indoor unit)	68
operation lamp	58	thermistor or related abnormality (outdoor unit)	71
outdoor heat exchanger thermistor	28, 72	thermistor resistance check	73
outdoor unit fan system check	75	thermostat control	22
P		TIMER operation	47
partition plate	107	titanium apatite photocatalytic air-purifying filter ...	27
piping diagrams	116	top plate	101
power failure recovery function	16, 113	trial operation	112
power-airflow dual flaps	20	troubleshooting	52, 63
POWERFUL operation	26, 46	V	
preparation before operation	40	V1	16
printed circuit board (PCB)		V2	16
control PCB	17, 64, 91	varistor	16
signal receiver PCB	17, 90	vertical blade	85
problem symptoms and measures	59	W	
programme dry function	24	wide-angle louvres	20
propeller fan	104	wiring diagrams	119
pump down operation	112		
R			
right side plate	105		
room temperature thermistor	68		
RTH	16		
S			
S1	16, 86		
S2	16		
S26	16		
S27	16		
S32	16		
S33	16		
S4	16		
S5	16		
S6	16, 86		
S7	16, 86		
safety precautions	35		
self-diagnosis digital display	27		
service check function	60		
service cover	81		
shelter	89, 103		
signal receiver	78		
signal receiver PCB	17, 90		
signal receiving sign	27		
sound blanket	105		
specifications	8		
stop valve cover	100		
SW1	16		
swing motor	86, 91		

Drawings & Flow Charts

A			
air flow rate control	21	RN35DAV3B	117
automatic operation	23	RN35DV3B	117
auto-swing	20	RYN25DAV3B	117
		RYN25DV3B	117
C		RYN35DAV3B	117
control PCB	17	RYN35DV3B	117
		POWERFUL operation	26
D		programme dry function	24
defrost control	31	pump down operation	112
diagnosis mode	61		
		S	
F		signal receiver PCB	17
fan motor or related abnormality	67		
freeze-up protection control or high pressure control	65	T	
		thermistor	28
H		thermistor or related abnormality (indoor unit)	68
Hall IC check	75	thermistor or related abnormality (outdoor unit)	71
heating peak-cut control	30	thermistor resistance check	73
high pressure control in cooling	69	thermostat control	22
		trial operation from remote controller	113
I			
indoor unit PCB abnormality	64	W	
installation condition check	74	wiring diagrams	
		ARY20DV2	120
J		ARY25DV2	120
jumper settings	113	ARY35DV2	121
		ATY20DV2	119
N		ATY25DV2	119
night set mode	25	ATY35DV2	119
		FTN25DAV3B	119
O		FTN25DV3B	119
ON/OFF button on indoor unit	27	FTN35DAV3B	119
operation lamp, location	58	FTN35DV3B	119
outdoor unit fan system check	75	FTYN25DAV3B	119
		FTYN25DV3B	119
P		FTYN35DAV3B	119
pipng diagrams		FTYN35DV3B	119
ARY20DV2	118	RN25DAV3B	120
ARY25DV2	118	RN25DV3B	120
ARY35DV2	118	RN35DAV3B	120
ATY20DV2	116	RN35DV3B	120
ATY25DV2	116	RYN25DAV3B	120
ATY35DV2	116	RYN25DV3B	120
FTN25DAV3B	116	RYN35DAV3B	120
FTN25DV3B	116	RYN35DV3B	120
FTN35DAV3B	116		
FTN35DV3B	116		
FTYN25DAV3B	116		
FTYN25DV3B	116		
FTYN35DAV3B	116		
FTYN35DV3B	116		
RN25DAV3B	117		
RN25DV3B	117		

Warning



- Daikin Industries, Ltd.'s products are manufactured for export to numerous countries throughout the world. Daikin Industries, Ltd. does not have control over which products are exported to and used in a particular country. Prior to purchase, please therefore confirm with your local authorised importer, distributor and/or retailer whether this product conforms to the applicable standards, and is suitable for use, in the region where the product will be used. This statement does not purport to exclude, restrict or modify the application of any local legislation.
- Ask a qualified installer or contractor to install this product. Do not try to install the product yourself. Improper installation can result in water or refrigerant leakage, electrical shock, fire or explosion.
- Use only those parts and accessories supplied or specified by Daikin. Ask a qualified installer or contractor to install those parts and accessories. Use of unauthorised parts and accessories or improper installation of parts and accessories can result in water or refrigerant leakage, electrical shock, fire or explosion.
- Read the User's Manual carefully before using this product. The User's Manual provides important safety instructions and warnings. Be sure to follow these instructions and warnings.

If you have any enquiries, please contact your local importer, distributor and/or retailer.

Cautions on product corrosion

1. Air conditioners should not be installed in areas where corrosive gases, such as acid gas or alkaline gas, are produced.
2. If the outdoor unit is to be installed close to the sea shore, direct exposure to the sea breeze should be avoided. If you need to install the outdoor unit close to the sea shore, contact your local distributor.



JMI-0107



JQA-1452

About ISO 9001

ISO 9001 is a plant certification system defined by the International Organization for Standardization (ISO) relating to quality assurance. ISO 9001 certification covers quality assurance aspects related to the "design, development, manufacture, installation, and supplementary service" of products manufactured at the plant.



EC99J2044

About ISO 14001

ISO 14001 is the standard defined by the International Organization for Standardization (ISO) relating to environmental management systems. Our group has been acknowledged by an internationally accredited compliance organisation as having an appropriate programme of environmental protection procedures and activities to meet the requirements of ISO 14001.

Dealer

DAIKIN INDUSTRIES, LTD.

Head Office:
Umeda Center Bldg., 2-4-12, Nakazaki-Nishi,
Kita-ku, Osaka, 530-8323 Japan

Tokyo Office:
JR Shinagawa East Bldg., 2-18-1, Konan,
Minato-ku, Tokyo, 108-0075 Japan

http://www.daikin.com/global_ac/

©All rights reserved