

DAIKIN

SiBE341027

R-410A

**Service
Manual**

VRV[®] III-Q

**Heat Pump R-410A 50Hz
RQYQ8-48PY1B**



VRV III-Q

Heat Pump

R-410A 50Hz

1. Introduction	iv
1.1 Safety Cautions	iv
1.2 Used Icons	viii
1.3 Preface	ix

Part 1 General Information 1

1. Model Names of Indoor / Outdoor Units.....	2
1.1 Indoor Units	2
1.2 Outdoor Units	3
1.3 Air Treatment Equipment	3
2. External Appearance.....	4
2.1 Indoor Units	4
2.2 Outdoor Units	5
2.3 Air Treatment Equipment	5
3. Combination of Outdoor Units.....	6
4. Capacity Range.....	7
5. Features	9
5.1 Introduction.....	9
5.2 Benefits of System Replacement	10
5.3 Procedure of Reuse of Existing Piping.....	12
5.4 Guidelines for Reuse of Existing Refrigerant Piping	14

Part 2 Specifications 17

1. Specifications	18
1.1 Outdoor Units	18

Part 3 Refrigerant Circuit 29

1. Refrigerant Circuit	30
1.1 RQYQ8PY1B.....	30
1.2 RQYQ10-12PY1B.....	32
1.3 RQYQ14-16PY1B.....	34
2. Functional Parts Layout	36
2.1 RQYQ8PY1B.....	36
2.2 RQYQ10-12PY1B.....	37
2.3 RQYQ14-16PY1B.....	38
3. Refrigerant Flow for Each Operation Mode.....	39
3.1 RQYQ8~16PY1B	39

Part 4 Function..... 42

1. Function General.....	43
--------------------------	----

1.1	Operation Mode.....	43
2.	Detailed Control Functions.....	44
2.1	Stop Operation.....	44
2.2	Standby.....	44
2.3	Startup Control.....	45
2.4	Normal Operation.....	46
2.5	Protection Control.....	51
2.6	Special Control.....	57
Part 5 Test Operation		60
1.	Test Operation.....	61
1.1	Procedure and Outline.....	61
1.2	Check Operation.....	64
1.3	Checking in Normal Operation.....	67
2.	Field Setting from Outdoor Unit.....	68
2.1	Field Setting from Outdoor Unit.....	68
Part 6 Service Diagnosis.....		90
1.	Symptom-based Troubleshooting.....	92
2.	Troubleshooting by Remote Controller.....	95
2.1	Procedure of Self-diagnosis by Remote Controller.....	95
2.2	PCB Abnormality.....	104
2.3	Actuation of High Pressure Switch or Pressure Switch.....	105
2.4	Actuation of High Pressure Switch (S1PH) or Pressure Switch (S2P).....	106
2.5	Actuation of Low Pressure Sensor.....	108
2.6	Inverter Compressor Motor Lock.....	110
2.7	STD Compressor Motor Overcurrent/Lock.....	112
2.8	Outdoor Unit Fan Motor Abnormality.....	113
2.9	Electronic Expansion Valve Coil Abnormality (Y1E~Y3E).....	116
2.10	Abnormal Discharge Pipe Temperature.....	118
2.11	Humidity Alarm.....	120
2.12	Refrigerant Overcharged.....	122
2.13	High Pressure Switch System Abnormality.....	123
2.14	Abnormal Outdoor Fan Motor Signal.....	124
2.15	Thermistor System Abnormality.....	126
2.16	High Pressure Sensor Abnormality.....	127
2.17	Current Sensor Abnormality.....	129
2.18	High Pressure Sensor Abnormality.....	130
2.19	Low Pressure Sensor Abnormality.....	132
2.20	Inverter PCB Abnormality.....	134
2.21	Inverter Radiation Fin Temperature Rise.....	136
2.22	Momentary Overcurrent of Inverter Compressor.....	137
2.23	Overcurrent Abnormal of Inverter Compressor.....	139
2.24	Inverter Compressor Starting Abnormality.....	141
2.25	Transmission System Error (between Inverter and Main PCB).....	143
2.26	Inverter Over-Ripple Protection.....	145
2.27	Inverter Radiation Fin Temperature Abnormality.....	147
2.28	Field Setting Abnormality after Replacing Main PCB or Combination Error of PCB.....	148
2.29	Refrigerant Shortage.....	149

2.30 Reverse Phase, Open Phase.....	151
2.31 Power Supply Insufficient or Instantaneous Failure	152
2.32 Check Operation is not Executed.....	155
2.33 Transmission Error (between Indoor and Outdoor Units).....	156
2.34 Transmission Error (between Remote Controller and Indoor Unit)	159
2.35 Transmission Error (Across Outdoor Units)	160
2.36 Transmission Error (between Main and Sub Remote Controllers).....	166
2.37 Transmission Error (between Indoor and Outdoor Units in the Same System).....	167
2.38 Improper Combination of Indoor and Outdoor Units, Indoor Units and Remote Controller.....	168
2.39 Address Duplication of Centralized Controller.....	172
2.40 Transmission Error (between Centralized Controller and Indoor Unit)	173
2.41 System is not Set yet.....	176
2.42 System Error, Refrigerant System Address Undefined	177
2.43 Check	179





Part 7 Appendix..... 195

1. Piping Diagrams.....	196
2. Wiring Diagrams.....	199
3. Accessories.....	202
3.1 Optional Accessories.....	202







1. Introduction



1.1 Safety Cautions









Cautions and Warnings

- Be sure to read the following safety cautions before conducting repair work.
- The caution items are classified into “ **Warning**” and “ **Caution**”. The “ **Warning**” items are especially important since they can lead to death or serious injury if they are not followed closely. The “ **Caution**” items can also lead to serious accidents under some conditions if they are not followed. Therefore, be sure to observe all the safety caution items described below.
- About the pictograms
 - △ This symbol indicates the item for which caution must be exercised.
The pictogram shows the item to which attention must be paid.
 - This symbol indicates the prohibited action.
The prohibited item or action is shown in the illustration or near the symbol.
 - This symbol indicates the action that must be taken, or the instruction.
The instruction is shown in the illustration or near the symbol.
- After the repair work is complete, be sure to conduct a test operation to ensure that the equipment operates normally, and explain the cautions for operating the product to the customer.











1.1.1 Cautions Regarding Safety of Workers





 Warning	
<p>Be sure to disconnect the power cable plug from the plug socket before disassembling the equipment for repair. Working on the equipment that is connected to the power supply may cause an electrical shock. If it is necessary to supply power to the equipment to conduct the repair or inspecting the circuits, do not touch any electrically charged sections of the equipment.</p>	
<p>If the refrigerant gas is discharged during the repair work, do not touch the discharged refrigerant gas. The refrigerant gas may cause frostbite.</p>	
<p>When disconnecting the suction or discharge pipe of the compressor at the welded section, evacuate the refrigerant gas completely at a well-ventilated place first. If there is a gas remaining inside the compressor, the refrigerant gas or refrigerating machine oil discharges when the pipe is disconnected, and it may cause injury.</p>	
<p>If the refrigerant gas leaks during the repair work, ventilate the area. The refrigerant gas may generate toxic gases when it contacts flames.</p>	
<p>The step-up capacitor supplies high-voltage electricity to the electrical components of the outdoor unit. Be sure to discharge the capacitor completely before conducting repair work. A charged capacitor may cause an electrical shock.</p>	
<p>Do not start or stop the air conditioner operation by plugging or unplugging the power cable plug. Plugging or unplugging the power cable plug to operate the equipment may cause an electrical shock or fire.</p>	







 Warning	
Be sure to wear a safety helmet, gloves, and a safety belt when working at a high place (more than 2 m). Insufficient safety measures may cause a fall accident.	
In case of R-410A refrigerant models, be sure to use pipes, flare nuts and tools for the exclusive use of the R-410A refrigerant. The use of materials for R-22 refrigerant models may cause a serious accident such as a damage of refrigerant cycle as well as an equipment failure.	





 Caution	
Do not repair the electrical components with wet hands. Working on the equipment with wet hands may cause an electrical shock.	
Do not clean the air conditioner by splashing water. Washing the unit with water may cause an electrical shock.	
Be sure to provide the grounding when repairing the equipment in a humid or wet place, to avoid electrical shocks.	
Be sure to turn off the power switch and unplug the power cable when cleaning the equipment. The internal fan rotates at a high speed, and cause injury.	
Be sure to conduct repair work with appropriate tools. The use of inappropriate tools may cause injury.	
Be sure to check that the refrigerating cycle section has cooled down enough before conducting repair work. Working on the unit when the refrigerating cycle section is hot may cause burns.	
Use the welder in a well-ventilated place. Using the welder in an enclosed room may cause oxygen deficiency.	

1.1.2 Cautions Regarding Safety of Users

 Warning	
<p>Be sure to use parts listed in the service parts list of the applicable model and appropriate tools to conduct repair work. Never attempt to modify the equipment. The use of inappropriate parts or tools may cause an electrical shock, excessive heat generation or fire.</p>	
<p>If the power cable and lead wires have scratches or deteriorated, be sure to replace them. Damaged cable and wires may cause an electrical shock, excessive heat generation or fire.</p>	
<p>Do not use a joined power cable or extension cable, or share the same power outlet with other electrical appliances, since it may cause an electrical shock, excessive heat generation or fire.</p>	
<p>Be sure to use an exclusive power circuit for the equipment, and follow the local technical standards related to the electrical equipment, the internal wiring regulations, and the instruction manual for installation when conducting electrical work. Insufficient power circuit capacity and improper electrical work may cause an electrical shock or fire.</p>	
<p>Be sure to use the specified cable for wiring between the indoor and outdoor units. Make the connections securely and route the cable properly so that there is no force pulling the cable at the connection terminals. Improper connections may cause excessive heat generation or fire.</p>	
<p>When wiring between the indoor and outdoor units, make sure that the terminal cover does not lift off or dismount because of the cable. If the cover is not mounted properly, the terminal connection section may cause an electrical shock, excessive heat generation or fire.</p>	
<p>Do not damage or modify the power cable. Damaged or modified power cable may cause an electrical shock or fire. Placing heavy items on the power cable, and heating or pulling the power cable may damage the cable.</p>	
<p>Do not mix air or gas other than the specified refrigerant (R-410A / R-22) in the refrigerant system. If air enters the refrigerating system, an excessively high pressure results, causing equipment damage and injury.</p>	
<p>If the refrigerant gas leaks, be sure to locate the leaking point and repair it before charging the refrigerant. After charging refrigerant, make sure that there is no refrigerant leak. If the leaking point cannot be located and the repair work must be stopped, be sure to perform pump down and close the service valve, to prevent the refrigerant gas from leaking into the room. The refrigerant gas itself is harmless, but it may generate toxic gases when it contacts flames, such as fan and other heaters, stoves and ranges.</p>	
<p>When relocating the equipment, make sure that the new installation site has sufficient strength to withstand the weight of the equipment. If the installation site does not have sufficient strength and if the installation work is not conducted securely, the equipment may fall and cause injury.</p>	





 Warning	
Check to make sure that the power cable plug is not dirty or loose, then insert the plug into a power outlet securely. If the plug has dust or loose connection, it may cause an electrical shock or fire.	
Be sure to install the product correctly by using the provided standard installation frame. Incorrect use of the installation frame and improper installation may cause the equipment to fall, resulting in injury.	For unitary type only 
Be sure to install the product securely in the installation frame mounted on the window frame. If the unit is not securely mounted, it may fall and cause injury.	For unitary type only 
When replacing the coin battery in the remote controller, be sure to disposed of the old battery to prevent children from swallowing it. If a child swallows the coin battery, see a doctor immediately.	

 Caution	
Installation of a leakage breaker is necessary in some cases depending on the conditions of the installation site, to prevent electrical shocks.	
Do not install the equipment in a place where there is a possibility of combustible gas leaks. If the combustible gas leaks and remains around the unit, it may cause a fire.	
Check to see if the parts and wires are mounted and connected properly, and if the connections at the soldered or crimped terminals are secure. Improper installation and connections may cause excessive heat generation, fire or an electrical shock.	
If the installation platform or frame has corroded, replace it. Corroded installation platform or frame may cause the unit to fall, resulting in injury.	
Check the grounding, and repair it if the equipment is not properly grounded. Improper grounding may cause an electrical shock.	

 Caution	
Be sure to measure the insulation resistance after the repair, and make sure that the resistance is 1 MΩ or higher. Defective insulation may cause an electrical shock.	
Be sure to check the drainage of the indoor unit after the repair. Defective drainage may cause the water to enter the room and wet the furniture and floor.	
Do not tilt the unit when removing it. The water inside the unit may spill and wet the furniture and floor.	
Be sure to install the packing and seal on the installation frame properly. If the packing and seal are not installed properly, water may enter the room and wet the furniture and floor.	For unitary type only 

1.2 Used Icons

Icons are used to attract the attention of the reader to specific information. The meaning of each icon is described in the table below:

Icon	Type of Information	Description
 Note:	Note	A “note” provides information that is not indispensable, but may nevertheless be valuable to the reader, such as tips and tricks.
 Caution	Caution	A “caution” is used when there is danger that the reader, through incorrect manipulation, may damage equipment, lose data, get an unexpected result or has to restart (part of) a procedure.
 Warning	Warning	A “warning” is used when there is danger of personal injury.
	Reference	A “reference” guides the reader to other places in this binder or in this manual, where he/she will find additional information on a specific topic.

1.3 Preface

Thank you for your continued patronage of Daikin products.

This is the new service manual for Daikin's Year 2011 VRVIII-Q series Heat Pump System. Daikin offers a wide range of models to respond to building and office air conditioning needs. We are confident that customers will be able to find the models that best suit their needs.

This service manual contains information regarding the servicing of VRVIII-Q series R-410A Heat Pump System.

March, 2011

After Sales Service Division

Part 1

General Information

1. Model Names of Indoor / Outdoor Units.....	2
1.1 Indoor Units	2
1.2 Outdoor Units	3
1.3 Air Treatment Equipment	3
2. External Appearance.....	4
2.1 Indoor Units	4
2.2 Outdoor Units	5
2.3 Air Treatment Equipment	5
3. Combination of Outdoor Units	6
4. Capacity Range.....	7
5. Features	9
5.1 Introduction.....	9
5.2 Benefits of System Replacement	10
5.3 Procedure of Reuse of Existing Piping.....	12
5.4 Guidelines for Reuse of Existing Refrigerant Piping	14

1. Model Names of Indoor / Outdoor Units

1.1 Indoor Units

Capacity range		0.8HP	1HP	1.25HP	1.6HP	2HP	2.5HP	3.2HP	4HP	5HP	6HP	8HP	10HP	Power Supply
Capacity index		20	25	31.25	40	50	62.5	80	100	125	140	200	250	
Ceiling Mounted Cassette Type (Round Flow)	FXFQ	—	25P9	32P9	40P9	50P9	63P9	80P9	100P9	125P9	—	—	—	VEB
Ceiling Mounted Cassette (Compact Multi Flow) Type	FXZQ	20M9	25M9	32M9	40M9	50M9	—	—	—	—	—	—	—	V1B
Ceiling Mounted Cassette Type (Double Flow)	FXCQ	20M8	25M8	32M8	40M8	50M8	63M8	80M8	—	125M8	—	—	—	V3B
Ceiling Mounted Cassette Corner Type	FXKQ	—	25MA	32MA	40MA	—	63MA	—	—	—	—	—	—	VE
Slim Ceiling Mounted Duct Type	FXDQ-PBVE	20PB	25PB	32PB	—	—	—	—	—	—	—	—	—	
	FXDQ-NBVE	—	—	—	40NB	50NB	63NB	—	—	—	—	—	—	
Ceiling Mounted Duct Type (Middle and high static pressure)	FXMQ	20P7	25P7	32P7	40P7	50P7	63P7	80P7	100P7	125P7	140P7	—	—	
Ceiling Mounted Duct Type	FXMQ	—	—	—	—	—	—	—	—	—	—	200MA	250MA	
Ceiling Suspended Type	FXHQ	—	—	32MA	—	—	63MA	—	100MA	—	—	—	—	
Wall Mounted Type	FXAQ	20P	25P	32P	40P	50P	63P	—	—	—	—	—	—	V1
Floor Standing Type	FXLQ	20P	25P	32P	40P	50P	63P	—	—	—	—	—	—	VE
Concealed Floor Standing Type	FXNQ	20MA	25MA	32MA	40MA	50MA	63MA	—	—	—	—	—	—	

Note: FXDQ has following 2 series, as shown below.

FXDQ-PBVE, NBVE: with Drain Pump

* It is possible to keep R-22 indoor units from K-series and later version. Field setting to R-22 on the PCB is necessary. For details, refer to the installation manual of RQYQ-P. It is not possible to combine old R-22 and new R-410A indoor units in one system due to incompatibility of communication.

RQYQ-P is not compatible to R-407C indoor units.

Connection unit series indoor units

Capacity range		3HP	4HP	5HP	Power Supply
Capacity index		71	100	125	
Ceiling Suspended Cassette Type	FXUQ	71MA	100MA	125MA	V1
Connection Unit for FXUQ	BEVQ	71MA	100MA	125MA	VE

Note: BEV unit is required for FXUQ only.

MA: RoHS Directive models; Specifications, dimensions and other functions are not changed compared with M type.

1.2 Outdoor Units

Series	Model Name								Power Supply
Heat Pump	RQYQ	8P	10P	12P	14P	16P	18P	20P	Y1B
		22P	24P	26P	28P	30P	32P	34P	
		36P	38P	40P	42P	44P	46P	48P	

Y1: 3 phase, 380-415V, 50Hz

1.3 Air Treatment Equipment

Outdoor-air processing unit

Series	Model name			Power supply
FXMQ	125MF	200MF	250MF	V1

HRV units (VKM series)

Series	Model name			Power supply	
HRV units with DX coil	VKM	50G	80G	100G	V1
HRV units with DX coil and humidifier		50GM	80GM	100GM	

Note: For details, refer to Engineering Data ED71-613.

HRV units (VAM series)













Series	Model name										Power supply
HRV units	VAM	150FA	250FA	350FA	500FA	650FA	800FA	1000FA	1500FA	2000FA	VE

VE: 1 phase, 220-240/220V, 50/60Hz

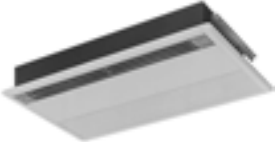







V1: 1 phase, 220-240V, 50Hz

2. External Appearance



2.1 Indoor Units

<p>Ceiling mounted cassette (Round flow) type</p> <p>FXFQ25P9VEB FXFQ32P9VEB FXFQ40P9VEB FXFQ50P9VEB FXFQ63P9VEB FXFQ80P9VEB FXFQ100P9VEB FXFQ125P9VEB</p> 	<p>Ceiling mounted duct type</p> <p>FXMQ200MAVE FXMQ250MAVE</p> 
<p>Ceiling mounted cassette (Compact multi flow) type</p> <p>FXZQ20M9V1B FXZQ25M9V1B FXZQ32M9V1B FXZQ40M9V1B FXZQ50M9V1B</p> 	<p>Ceiling suspended type</p> <p>FXHQ32MAVE FXHQ63MAVE FXHQ100MAVE</p> 
<p>Ceiling mounted cassette (Double flow) type</p> <p>FXCQ20M8V3B FXCQ25M8V3B FXCQ32M8V3B FXCQ40M8V3B FXCQ50M8V3B FXCQ63M8V3B FXCQ80M8V3B FXCQ125M8V3B</p> 	<p>Wall mounted type</p> <p>FXAQ20PV1 FXAQ25PV1 FXAQ32PV1 FXAQ40PV1 FXAQ50PV1 FXAQ63PV1</p> 
<p>Ceiling mounted cassette corner type</p> <p>FXKQ25MAVE FXKQ32MAVE FXKQ40MAVE FXKQ63MAVE</p> 	<p>Floor standing type</p> <p>FXLQ20PVE FXLQ25PVE FXLQ32PVE FXLQ40PVE FXLQ50PVE FXLQ63PVE</p> 
<p>Slim ceiling mounted duct type</p> <p>FXDQ20PBVE FXDQ25PBVE FXDQ32PBVE FXDQ40NBVE FXDQ50NBVE FXDQ63NBVE with a Drain Pump (VE)</p> 	<p>Concealed floor standing type</p> <p>FXNQ20PVE FXNQ25PVE FXNQ32PVE FXNQ40PVE FXNQ50PVE FXNQ63PVE</p> 
<p>Ceiling mounted duct type (Middle and high static pressure)</p> <p>FXMQ20P7VE FXMQ63P7VE FXMQ25P7VE FXMQ80P7VE FXMQ32P7VE FXMQ100P7VE FXMQ40P7VE FXMQ125P7VE FXMQ50P7VE FXMQ140P7VE</p> 	<p>Ceiling suspended cassette type</p> <p>50Hz FXUQ71MAV1 + BEVQ71MAVE FXUQ100MAV1 + BEVQ100MAVE FXUQ125MAV1 + BEVQ125MAVE</p> <p>Connection unit</p> 

2.2 Outdoor Units

8, 10, 12HP	14, 16HP	18, 20, 22, 24HP
 <p>RQYQ8PY1B RQYQ10PY1B RQYQ12PY1B</p>	 <p>RQYQ14PY1B RQYQ16PY1B</p>	 <p>RQYQ18PY1B RQYQ20PY1B RQYQ22PY1B RQYQ24PY1B</p>
26, 28HP	30, 32HP	34, 36, 38, 40HP
 <p>RQYQ26PY1B RQYQ28PY1B</p>	 <p>RQYQ30PY1B RQYQ32PY1B</p>	 <p>RQYQ34PY1B RQYQ36PY1B RQYQ38PY1B RQYQ40PY1B</p>
42, 44HP		46, 48HP
 <p>RQYQ42PY1B RQYQ44PY1B</p>		 <p>RQYQ46PY1B RQYQ48PY1B</p>

2.3 Air Treatment Equipment

<p>Outdoor-air processing unit</p> <p>FXMQ125MFV1 FXMQ200MFV1 FXMQ250MFV1</p> 	<p>HRV units (VKM series)</p> <p>VKM50GV1 / VKM50GMV1 VKM80GV1 / VKM80GMV1 VKM100GV1 / VKM100GMV1</p> <p>with DX coil (G) with DX coil and humidifier (GM)</p> 	<p>HRV units (VAM series)</p> <p>VAM150FAVE VAM250FAVE VAM350FAVE VAM500FAVE VAM650FAVE VAM800FAVE VAM1000FAVE VAM1500FAVE VAM2000FAVE</p> 
---	--	--

3. Combination of Outdoor Units

System Capacity	Number of units	Module					Outdoor Unit Multi Connection Piping Kit (Option)
		8	10	12	14	16	
8HP	1	●					—
10HP	1		●				
12HP	1			●			
14HP	1				●		
16HP	1					●	
18HP	1	●	●				Heat Pump: BHFP22P100
20HP	2	●		●			
22HP	2		●	●			
24HP	2			●●			
26HP	2		●			●	
28HP	2			●		●	
30HP	2				●	●	
32HP	2					●●	
34HP	2		●●		●		Heat Pump: BHFP22P151
36HP	2		●●			●	
38HP	3		●	●		●	
40HP	3			●●		●	
42HP	3		●			●●	
44HP	3			●		●●	
46HP	3				●	●●	
48HP	3					●●●	

Note: For multiple connection of 18HP system or more, an optional Daikin Outdoor Unit Multi Connection Piping Kit is required.

4. Capacity Range

Combination ratio

Connection capacity: 50% - 130%

$$\text{Combination ratio} = \frac{\text{Total capacity index of the indoor units}}{\text{Capacity index of the outdoor units}}$$

Type	Min. combination ratio	Max. combination ratio				
		Standard indoor units	Type of connected Air Treatment Equipments			
			VKM		FXMQ-MF	
			When VKM is only connected	When VKM and indoor units are connected	When FXMQ-MF is only connected	When FXMQ-MF and indoor units are connected
Single outdoor units	50%	130%	130%	130%	100%	100%*
Double outdoor units						
Triple outdoor units						

Note: * When outdoor-air processing units (FXMQ-MF) and standard indoor units are connected, the total connection capacity of the outdoor-air processing units (FXMQ-MF) must not exceed 30% of the capacity index of the outdoor units.

Outdoor unit combinations

HP	Capacity index	Model name	Combination	Outdoor unit multi connection piping kit ¹	Total capacity index of connectable indoor units ^{2,3}			Maximum number of connectable indoor units
					Combination (%)			
					50%	100%	130%	
8 HP	200	RQYQ8PY1B	RQYQ8PY1B	—	100	200	260	13
10 HP	250	RQYQ10PY1B	RQYQ10PY1B	—	125	250	325	16
12 HP	300	RQYQ12PY1B	RQYQ12PY1B	—	150	300	390	19
14 HP	350	RQYQ14PY1B	RQYQ14PY1B	—	175	350	455	22
16 HP	400	RQYQ16PY1B	RQYQ16PY1B	—	200	400	520	26
18 HP	450	RQYQ18PY1B	RQYQ8PY1B + RQYQ10PY1B	BHFP22P100	225	450	585	29
20 HP	500	RQYQ20PY1B	RQYQ8PY1B + RQYQ12PY1B		250	500	650	32
22 HP	550	RQYQ22PY1B	RQYQ10PY1B + RQYQ12PY1B		275	550	715	35
24 HP	600	RQYQ24PY1B	RQYQ12PY1B + RQYQ12PY1B		300	600	780	39
26 HP	650	RQYQ26PY1B	RQYQ10PY1B + RQYQ16PY1B		325	650	845	42
28 HP	700	RQYQ28PY1B	RQYQ12PY1B + RQYQ16PY1B		350	700	910	45
30 HP	750	RQYQ30PY1B	RQYQ14PY1B + RQYQ16PY1B		375	750	975	48
32 HP	800	RQYQ32PY1B	RQYQ16PY1B + RQYQ16PY1B		400	800	1,040	52
34 HP	850	RQYQ34PY1B	RQYQ10PY1B + RQYQ10PY1B + RQYQ14PY1B		425	850	1,105	55
36 HP	900	RQYQ36PY1B	RQYQ10PY1B + RQYQ10PY1B + RQYQ16PY1B		450	900	1,170	58
38 HP	950	RQYQ38PY1B	RQYQ10PY1B + RQYQ12PY1B + RQYQ16PY1B	475	950	1,235	61	
40 HP	1,000	RQYQ40PY1B	RQYQ12PY1B + RQYQ12PY1B + RQYQ16PY1B	BHFP22P151	500	1,000	1,300	64
42 HP	1,050	RQYQ42PY1B	RQYQ10PY1B + RQYQ16PY1B + RQYQ16PY1B		525	1,050	1,365	
44 HP	1,100	RQYQ44PY1B	RQYQ12PY1B + RQYQ16PY1B + RQYQ16PY1B		550	1,100	1,430	
46 HP	1,150	RQYQ46PY1B	RQYQ14PY1B + RQYQ16PY1B + RQYQ16PY1B		575	1,150	1,495	
48 HP	1,200	RQYQ48PY1B	RQYQ16PY1B + RQYQ16PY1B + RQYQ16PY1B		600	1,200	1,560	

*1. For multiple connections of 18 HP systems and above, the outdoor unit multi connection piping kit (separately sold) is required.

*2. Total capacity index of connectable indoor units must be 50%–130% of the capacity index of the outdoor units.

*3. When outdoor-air processing units (FXMQ-MF) and standard indoor units are connected, the total connection capacity of the outdoor-air processing units (FXMQ-MF) must not exceed 30% of the capacity index of the outdoor units.

Indoor unit connection capacity

Type	HP	Capacity index	Model name	Types of connected indoor units		
				Min. combination ratio	Standard indoor units	
					Max. combination ratio	Max. number of connectable indoor units
Single outdoor units	8	200	RQYQ8PY1B	50%	130%	13
	10	250	RQYQ10PY1B			16
	12	300	RQYQ12PY1B			19
	14	350	RQYQ14PY1B			22
	16	400	RQYQ16PY1B			26
Double outdoor units	18	450	RQYQ18PY1B			29
	20	500	RQYQ20PY1B			32
	22	550	RQYQ22PY1B			35
	24	600	RQYQ24PY1B			39
	26	650	RQYQ26PY1B			42
	28	700	RQYQ28PY1B			45
	30	750	RQYQ30PY1B			48
Triple outdoor units	32	800	RQYQ32PY1B			52
	34	850	RQYQ34PY1B			55
	36	900	RQYQ36PY1B			58
	38	950	RQYQ38PY1B	61		
	40	1,000	RQYQ40PY1B	64		
	42	1,050	RQYQ42PY1B			
	44	1,100	RQYQ44PY1B			
	46	1,150	RQYQ46PY1B			
	48	1,200	RQYQ48PY1B			

5. Features

5.1 Introduction

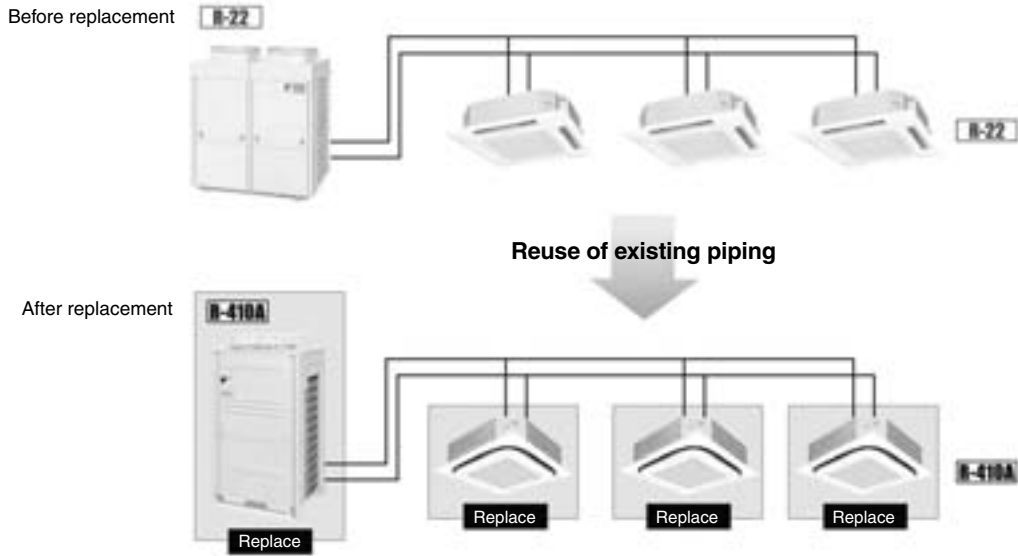

* It is possible to keep R-22 indoor units from K-series and later version. It is not possible to combine old R-22 and new R-410A indoor units in one system due to incompatibility of communication.

Enables smooth replacement of air conditioning with less effect on operations and users in the building.

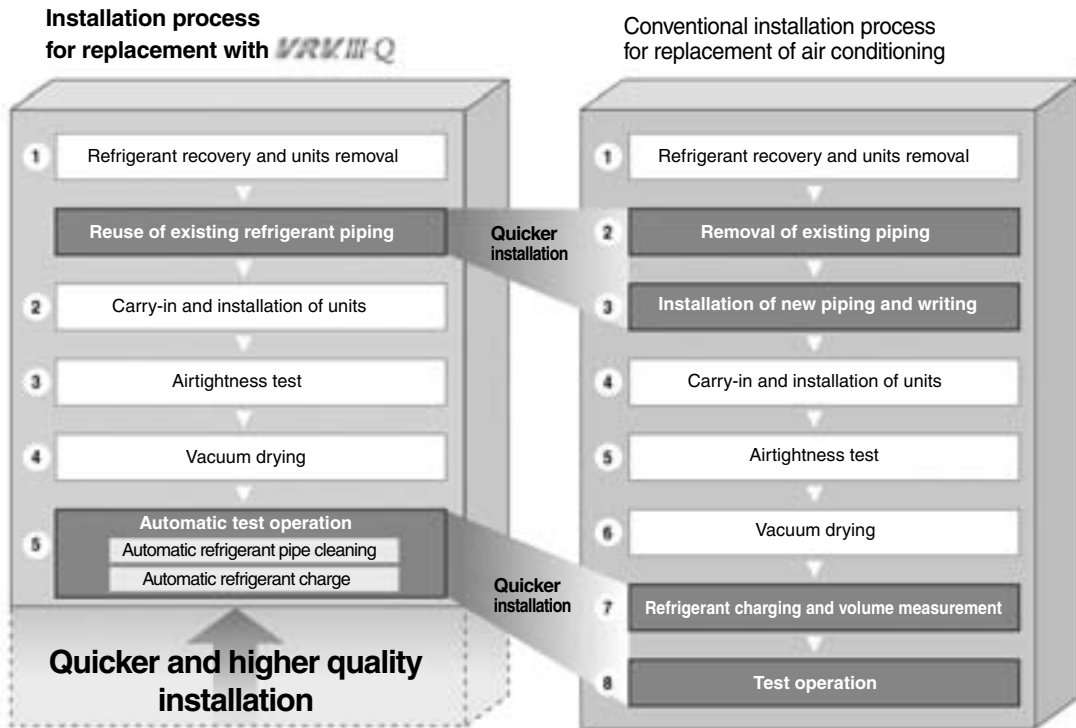

* For reuse of existing refrigerant piping, it is possible to use piping or branched piping capable of handling 3.3 Pa or more. Heat insulation is necessary for liquid piping and gas piping.

5.2 Benefits of System Replacement

High COP

Saves energy with high COP

We have reached a higher level of efficiency, thanks to advanced features such as the heat exchanger, the grille and the dual DC fans.



• Cooling operating conditions: Indoor temp. of 27 °CDB, 19.0 °CWB, and outdoor temp. of 35 °CDB.

Comparison of VRV III - Q and VRV K series

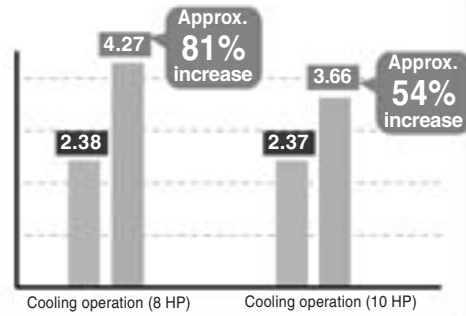

Design flexibility

Significantly more compact outdoor unit enables the effective use of limited space!

Compact design enables the effective use of space taken up by existing machinery

Conventional VRV K PLUS series: RX(Y)16K
(model from 14 years previous)
16 HP outdoor unit

VRV III-Q : RQYQ16P
16 HP outdoor unit

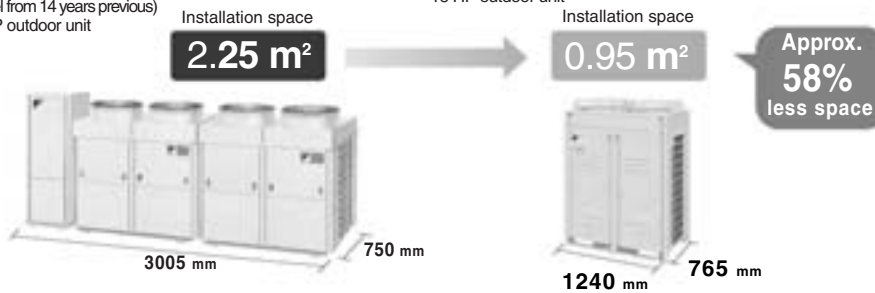

High external static pressure 78.4 Pa

Conventional VRV K series
(model from 14 years previous)

49.0 Pa → 78.4 Pa

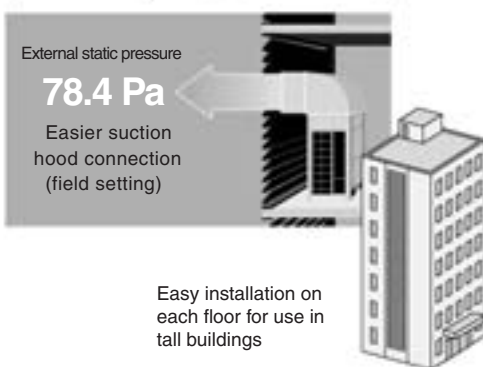

Small and light, significantly reducing constraints during carry-in

Carry-in possible using ordinary elevators

Easy belt suspension

Can be carried on a fork-lift without a pallet

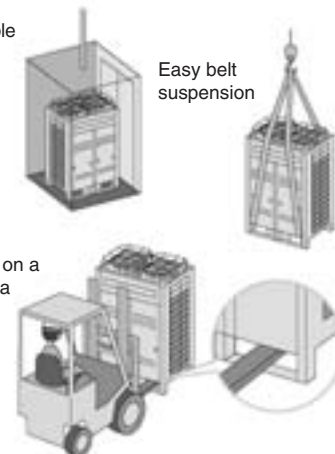

System flexibility

An increased number of connectable indoor units in a single system

More indoor units can be connected in a single system, enabling consolidation of existing piping!

The number of connectable indoor units has been drastically increased from 30 to 64.

Conventional
VRV K PLUS series: RX(Y) 24 - 30K
(model from 14 years previous)

Up to 30 indoor units connectable

VRV III-Q :RQYQ40 - 48P

Up to 64 indoor units connectable

Condensed into a single system

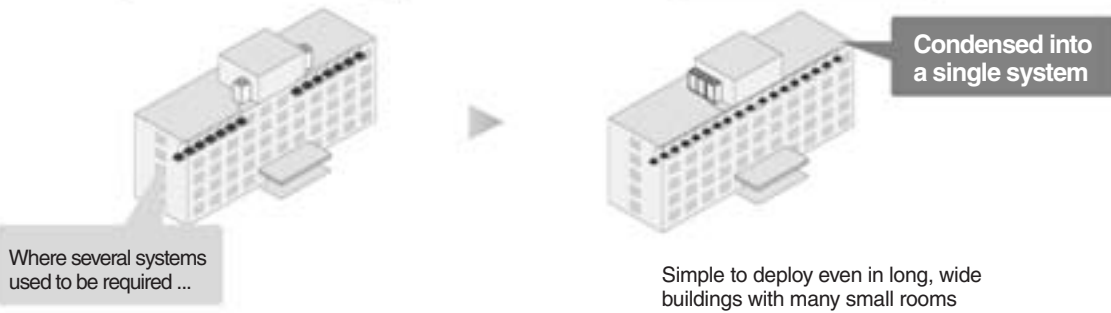

Enables increased capacity

System can be upgraded using existing piping

VRV III - Q for replacement use enables the system capacity to be increased without changing the refrigerant piping. For example, it is possible to install a 16 HP VRV III - Q using the refrigerant piping of an 10 HP R - 22 system.

Before replacement
10 HP

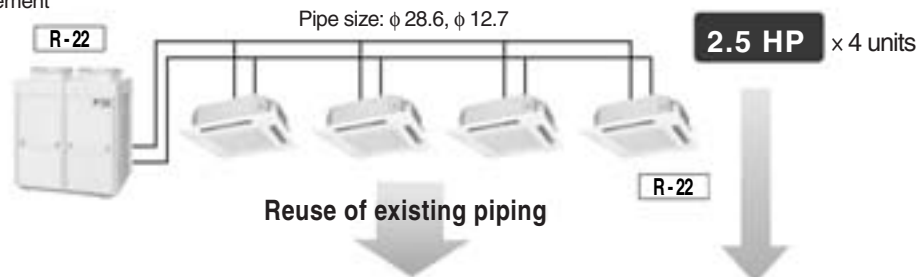

Reuse of existing piping

After replacement
VRV III-Q
16 HP

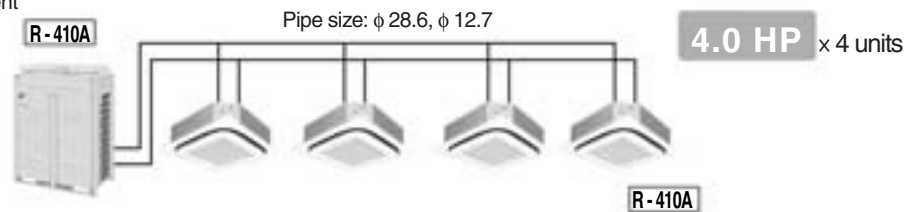

* For reuse of existing refrigerant piping, it is possible to use piping or branched piping capable of handling 3.3 Pa or more. Heat insulation is necessary for liquid piping and gas piping.

5.3 Procedure of Reuse of Existing Piping

If you are using the existing piping, follow the steps below:

Check whether the existing refrigerant piping is available or not.

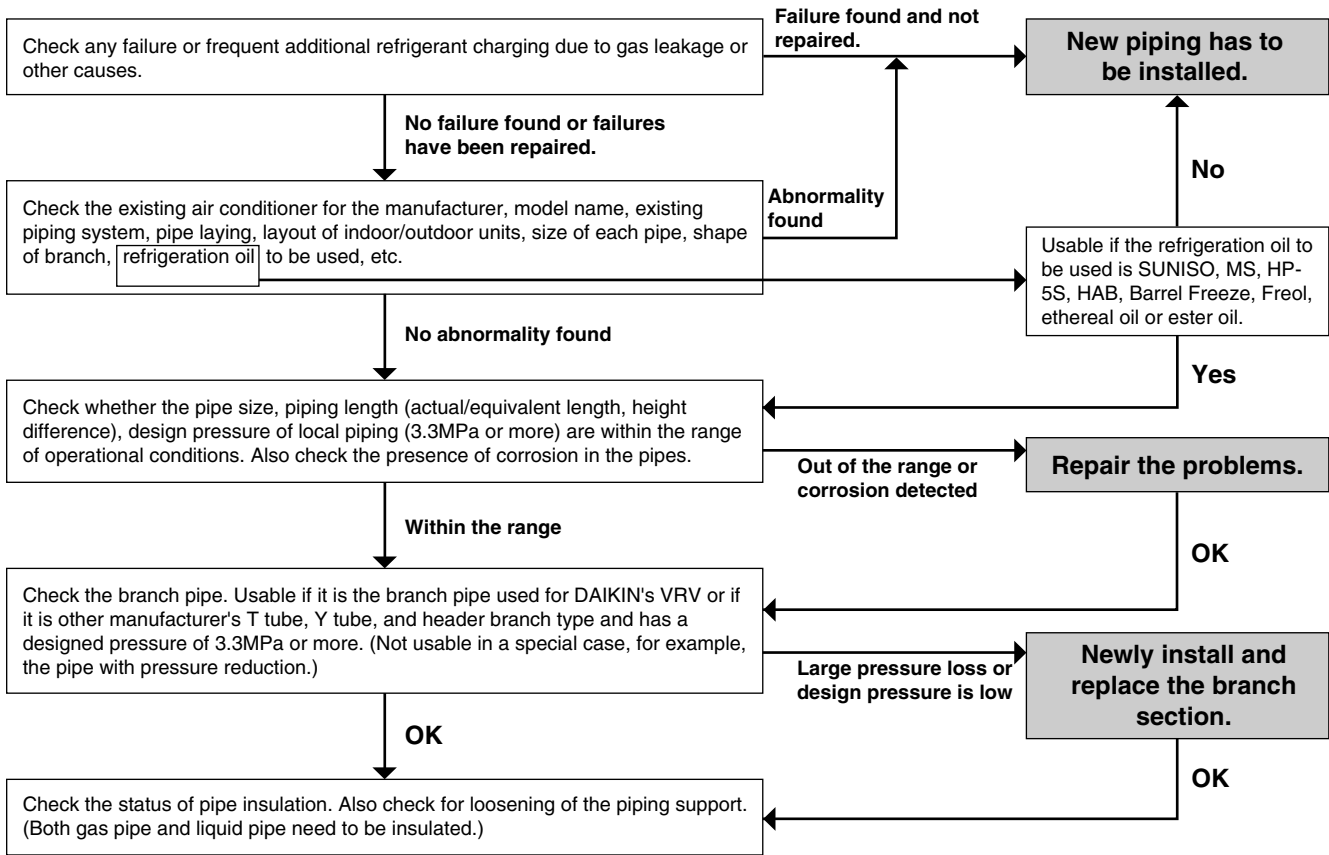

Refrigerant recovery in current system (R-22, R-407C)

(Continued on the next page)

(Continued for the previous page)

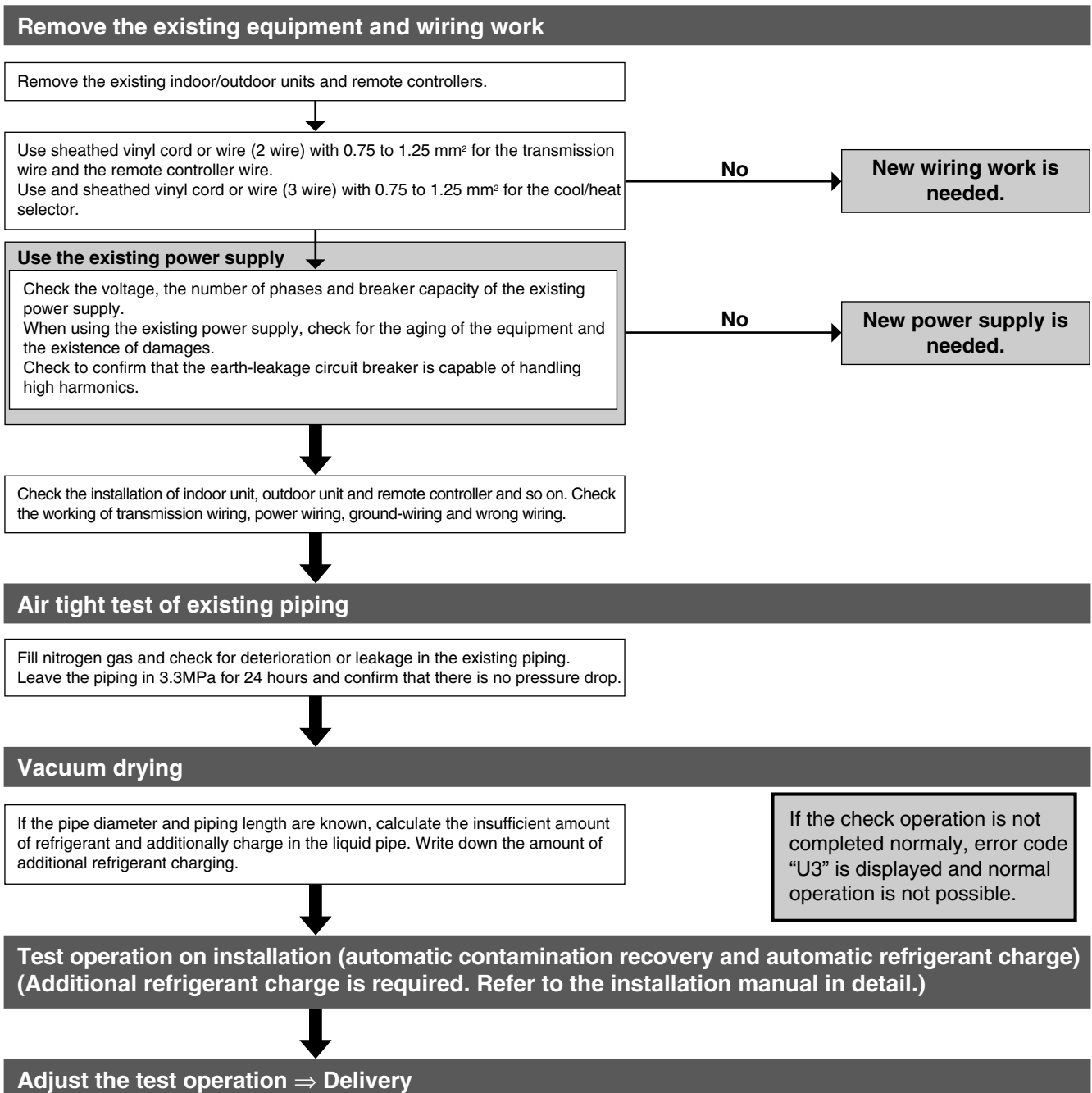

5.4 Guidelines for Reuse of Existing Refrigerant Piping

■ Piping limits for reuse of existing piping

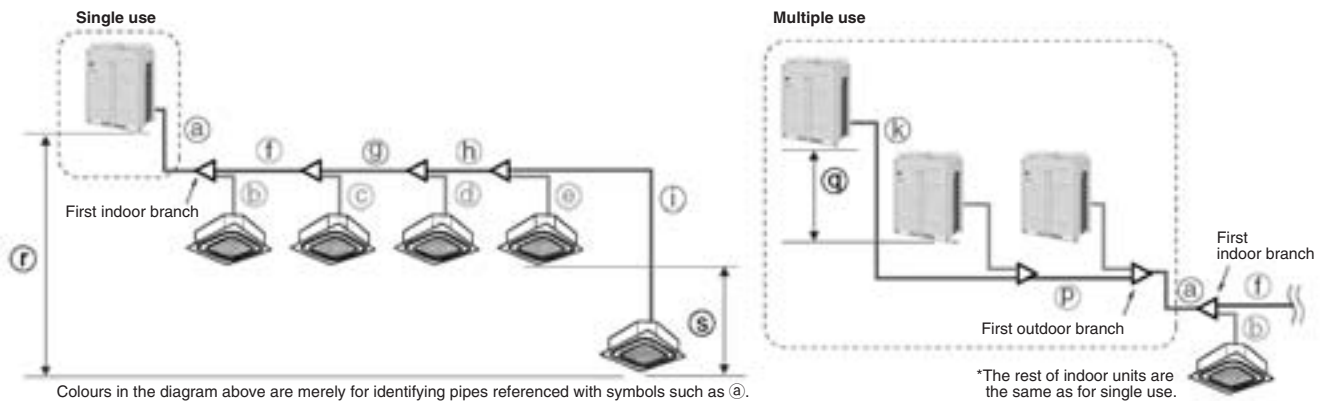

		Actual piping length	Example	Equivalent piping length	
Maximum allowable piping length	Refrigerant piping length	150 m	a+f+g+h+i	175 m	
	Total piping length	300 m	a+b+c+d+e+f+g+h+i	—	
	Between the first indoor branch and the farthest indoor unit	40 m	f+g+h+i	—	
	Between the outdoor branch and the last outdoor unit	10 m	k+p	13 m	
		Level Difference	Example		
Maximum allowable level difference	Between the outdoor units (Multiple use)	5 m	q		
	Between the indoor units	15 m	s		
	Between the outdoor units and the indoor units	If the outdoor unit is above.	50 m	r	
		If the outdoor unit is below.	40 m	r	

■ Existing refrigerant piping

Branch pipe

Pipe without corrosion whose withstanding pressure is 3.3MPa or more can be used

>> it can be used with “T pipe”, “Y pipe”, “header”

* The special pipe with the pressure reduction cannot be used.

- For the connection pipe for outdoor unit, only Y pipe, which is the kit dedicated to the necessary option, can be used

Type of pipe

Pipe without corrosion whose withstanding pressure is 3.3MPa or more can be used

- When reuse R22 Indoor unit, process the flare of existing piping for R-410A again.
- When reuse R22 Indoor unit, use the flare nut for R-410A.
- For the thickness etc., refer to P.15.

→ Existing Daikin R-22 piping meets the minimum thickness of VRVIII-Q.

>> The “insulation of gas pipe only” is not supported.

Use the “insulation of both liquid and gas pipes”.

When replacing K(A) series or previous version, please confirm piping is “insulation of both liquid and gas pipes.”

Refrigerant oil

SUNISO, MS, HAB, Barrel Freeze, Freol, Ether oil, Ester oil, and HP-5S can be used.

■ **For the existing piping, please check the followings**

- The existing piping should meet the condition of design pressure 3.3MPa.
Concretely, it should meet the minimum thickness for VRVIII-Q shown in the table below.
→ Existing Daikin R-22 piping meets the minimum thickness of VRVIII-Q.
- The existing piping should not be corroded on the external appearance.

Outer diameter of piping	VRVIII-Q		Daikin for R-22 (for reference)	
	Material	Minimum thickness (mm)	Material	Minimum thickness (mm)
φ6.4	○	0.4	○	0.80
φ9.5	○	0.5	○	0.80
φ12.7	○	0.7	○	0.80
φ15.9	○	0.9	○	0.99
φ19.1	1/2H	0.6	○	0.80
φ22.2	1/2H	0.6	1/2H	0.80
φ25.4	1/2H	0.7	1/2H	0.88
φ28.6	1/2H	0.8	1/2H	0.99
φ31.8	1/2H	0.9	1/2H	1.10
φ34.9	1/2H	1.0	1/2H	1.21
φ38.1	1/2H	1.1	1/2H	1.32
φ41.3	1/2H	1.1	1/2H	1.43

Taper grade (O type, 1/2H type) in the table indicate the material types specified in JIS H3300.

In case of bending O material, set the round bending to 3xD or more (D: Outer Diameter)

1/2H materials are calculated without setting the bending.

■ Reusability of existing piping for VRVIII-Q

- Pipe size selection

<for individual systems>

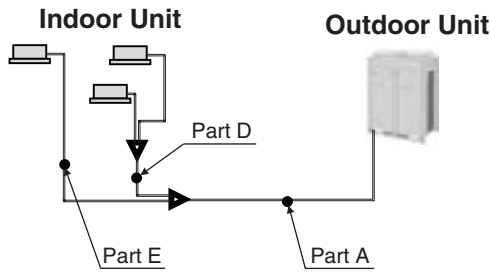

<for multi-connecting systems>

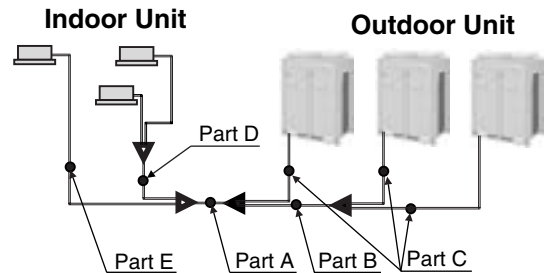

Type of piping	Capacity	Piping size														
		Liquid						Gas								
		φ 6.4	φ 9.5	φ 12.7	φ 15.9	φ 19.1	φ 22.2	φ 12.7	φ 15.9	φ 19.1	φ 22.2	φ 25.4	φ 28.6	φ 34.9	φ 41.3	φ 54.1
Main piping (Part A) (Part B) (Part C)	8 HP	x	S○	●		x	x	x	x	S○	●		x	x	x	x
	10 HP	x	S○	●		x	x	x	x	S○	●		x	x	x	x
	12 HP	x	x	S○	●	x	x	x	x	x	x	S○	●	x	x	x
	14 HP	x	x	S○	●	x	x	x	x	x	x	S○	●	x	x	x
	16 HP	x	x	S○	●	x	x	x	x	x	x	S○	●	x	x	x
	18 HP	x	x	x	S○	●	x	x	x	x	x	S○	●	x	x	x
	20 HP	x	x	x	S○	●	x	x	x	x	x	S○	●	x	x	x
	22 HP	x	x	x	S○	●	x	x	x	x	x	S○	●	x	x	x
	24 HP	x	x	x	S○	●	x	x	x	x	x	x	S○	●	x	x
	26 HP	x	x	x	x	S○	●	x	x	x	x	x	S○	●	x	x
	28 HP	x	x	x	x	S○	●	x	x	x	x	x	S○	●	x	x
	30 HP	x	x	x	x	S○	●	x	x	x	x	x	S○	●	x	x
	32 HP	x	x	x	x	S○	●	x	x	x	x	x	S○	●	x	x
	34 HP	x	x	x	x	S○	●	x	x	x	x	x	S○	●	x	x
	36 HP	x	x	x	x	S○	●	x	x	x	x	x	x	S○	●	x
	38 HP	x	x	x	x	S○	●	x	x	x	x	x	x	S○	●	x
	40 HP	x	x	x	x	S○	●	x	x	x	x	x	x	S○	●	x
42 HP	x	x	x	x	S○	●	x	x	x	x	x	x	S○	●	x	
44 HP	x	x	x	x	S○	●	x	x	x	x	x	x	S○	●	x	
46 HP	x	x	x	x	S○	●	x	x	x	x	x	x	S○	●	x	
48 HP	x	x	x	x	S○	●	x	x	x	x	x	x	S○	●	x	
From REFNET to REFNET ^{*1} (Part D)	< 100	x	S○	●	x	x	x	S○	●		x	x	x	x	x	x
	100 ≤ X < 150	x	S○	●	x	x	x	x	S○	●	x	x	x	x	x	x
	150 ≤ X < 160	x	S○	●	x	x	x	x	x	S○	●	x	x	x	x	x
	160 ≤ X < 200	x	S○	●	x	x	x	x	x	S○	●	x	x	x	x	x
	200 ≤ X < 290	x	S○	●	x	x	x	x	x	S○	●	x	x	x	x	x
	290 ≤ X < 330	x	x	S○	●	x	x	x	x	x	●	S○		x	x	x
	330 ≤ X < 420	x	x	S○	●	x	x	x	x	x	x	S○	●	x	x	x
	420 ≤ X < 480	x	x	S	○●		x	x	x	x	x	S○	●	x	x	x
	480 ≤ X < 640	x	x	S	○	●	x	x	x	x	x	S○	●	x	x	x
	640 ≤ X < 900	x	x	x	S	○●		x	x	x	x	x	S○	●	x	x
900 ≤ X < 920	x	x	x	S	○	●	x	x	x	x	x	S○	●	x	x	
920 ≤	x	x	x	x	S○	●	x	x	x	x	x	x	S○	●	x	
From REFNET to indoor unit ^{*2} (Part E)	20-40 class	S○	●	x	x	x	x	S○	●	x	x	x	x	x	x	x
	50 class	S○	●	x	x	x	x	S○	●	x	x	x	x	x	x	x
	63 class	x	S○	●	x	x	x	○	S○	x	x	x	x	x	x	x
	80 class	x	S○	●	x	x	x	x	S○	●	x	x	x	x	x	x
	100-125 class	x	S○	●	x	x	x	x	S○	●		x	x	x	x	x
	140 class	x	S○	●	x	x	x	x	S○	●		x	x	x	x	x
	200 class	x	S○	●	x	x	x	x	x	S○	●		x	x	x	x
250 class	x	S○	●	x	x	x	x	x	x	S○	●		x	x	x	

Part A: Piping between Outdoor unit and Refrigerant branch connection

Part B: Piping between Outdoor unit connection piping kits

Part C: Piping between Outdoor unit connection piping kit and Outdoor unit

Part D: Piping between Refrigerant branch kit

Part E: Piping between Refrigerant branch connection and Indoor unit

● : Piping size of conventional R-22 model

○ : Piping size of conventional R-410A model

S : Standard piping size of VRVIII-Q

■ : Possible

▨ : Standard piping size of VRV III-Q. However, when equivalent piping length between outdoor unit and indoor unit is 90 m or more, size of main piping must be increased. See the installation manual.

x : Not possible

*1 Piping between REFNETs depends on total capacity index of indoor units connected below each REFNET. It cannot exceed piping size of upstream side.

*2 Piping from REFNET to indoor unit depends on the capacity of the connected indoor unit. It cannot exceed piping size of upstream side.

Part 2 Specifications

1. Specifications	18
1.1 Outdoor Units	18

1. Specifications

1.1 Outdoor Units

Model Name		RQYQ8PY1B		RQYQ10PY1B		
★1 Cooling Capacity (19.5°CWB)	kcal / h	19,400		24,300		
	Btu / h	76,800		96,200		
	kW	22.5		28.2		
★2 Cooling Capacity (19.0°CWB)	kW	22.4		28.0		
★3 Heating Capacity	kcal / h	21,500		27,100		
	Btu / h	85,300		107,000		
	kW	25.0		31.5		
Casing Colour		Ivory White (5Y7.5/1)		Ivory White (5Y7.5/1)		
Dimensions: (HxWxD)		mm	1680x930x765		1680x930x765	
Heat Exchanger		Cross Fin Coil		Cross Fin Coil		
Comp.	Type		Hermetically Sealed Scroll Type		Hermetically Sealed Scroll Type	
	Displacement	m ³ /h	16.90		13.34+10.53	
	Number of Revolutions	r/min	7980		6300, 2900	
	Motor Output×Number of Units	kW	4.5×1		(1.4+4.5)×1	
	Starting Method		Soft Start		Soft Start	
Fan	Type		Propeller Fan		Propeller Fan	
	Motor Output	kW	0.75×1		0.75×1	
	Airflow Rate	m ³ /min	180		185	
	Drive		Direct Drive		Direct Drive	
Connecting Pipes	Liquid Pipe	mm	φ9.5 (Brazing Connection)		φ9.5 (Brazing Connection)	
	Gas Pipe	mm	φ19.1 (Brazing Connection)		φ22.2 (Brazing Connection)	
Product Mass (Machine weight)		kg	230		284	
Safety Devices		High Pressure Switch, Fan Driver Overload Protector, Overcurrent Relay, Inverter Overload Protector		High Pressure Switch, Fan Driver Overload Protector, Overcurrent Relay, Inverter Overload Protector		
Defrost Method		Deicer		Deicer		
Capacity Control		%	20~100		14~100	
Refrigerant	Refrigerant Name		R-410A		R-410A	
	Charge	kg	10.8		11.7	
	Control		Electronic Expansion Valve		Electronic Expansion Valve	
Refrigerator Oil		Refer to the nameplate of compressor		Refer to the nameplate of compressor		
Standard Accessories		Installation Manual, Operation Manual, Connection Pipes, Clamps		Installation Manual, Operation Manual, Connection Pipes, Clamps		
Drawing No.		4D070260		4D070261		

Note:

- ★1 Indoor temp. : 27°CDB, 19.5°CWB / outdoor temp. : 35°CDB / Equivalent piping length : 7.5m, level difference : 0m.
- ★2 Indoor temp. : 27°CDB, 19.0°CWB / outdoor temp. : 35°CDB / Equivalent piping length : 7.5m, level difference : 0m.
- ★3 Indoor temp. : 20°CDB / outdoor temp. : 7°CDB, 6°CWB / Equivalent piping length : 7.5m, level difference : 0m.

Conversion Formulae

kcal/h=kW×860
 Btu/h=kW×3412
 cfm=m³/min×35.3

Model Name			RQYQ12PY1B	RQYQ14PY1B
★1 Cooling Capacity (19.5°CWB)	kcal / h		29,000	34,600
	Btu / h		115,000	137,000
	kW		33.7	40.2
★2 Cooling Capacity (19.0°CWB)	kW		33.5	40.0
★3 Heating Capacity	kcal / h		32,300	38,700
	Btu / h		128,000	154,000
	kW		37.5	45.0
Casing Colour			Ivory White (5Y7.5/1)	Ivory White (5Y7.5/1)
Dimensions: (H×W×D)		mm	1680×930×765	1680×1240×765
Heat Exchanger			Cross Fin Coil	Cross Fin Coil
Comp.	Type		Hermetically Sealed Scroll Type	Hermetically Sealed Scroll Type
	Displacement	m ³ /h	13.34+10.53	13.34+10.53+10.53
	Number of Revolutions	r/min	6300, 2900	6300, 2900, 2900
	Motor Output×Number of Units	kW	(3.3+4.5)×1	(1.6+4.5+4.5)×1
	Starting Method			Soft Start
Fan	Type		Propeller Fan	Propeller Fan
	Motor Output	kW	0.75×1	0.35×2
	Airflow Rate	m ³ /min	200	233
	Drive		Direct Drive	Direct Drive
Connecting Pipes	Liquid Pipe	mm	φ12.7 (Brazing Connection)	φ12.7 (Brazing Connection)
	Gas Pipe	mm	φ28.6 (Brazing Connection)	φ28.6 (Brazing Connection)
Product Mass (Machine Weight)		kg	284	381
Safety Devices			High Pressure Switch, Fan Driver Overload Protector, Overcurrent Relay, Inverter Overload Protector	High Pressure Switch, Fan Driver Overload Protector, Overcurrent Relay, Inverter Overload Protector
Defrost Method			Deicer	Deicer
Capacity Control		%	14~100	10~100
Refrigerant	Refrigerant Name		R-410A	R-410A
	Charge	kg	11.7	11.7
	Control		Electronic Expansion Valve	Electronic Expansion Valve
Refrigerator Oil			Refer to the nameplate of compressor	Refer to the nameplate of compressor
Standard Accessories			Installation Manual, Operation Manual, Connection Pipes, Clamps	Installation Manual, Operation Manual, Connection Pipes, Clamps
Drawing No.			4D070262	4D070263

Note:

- ★1 Indoor temp. : 27°CDB, 19.5°CWB / outdoor temp. : 35°CDB / Equivalent piping length : 7.5m, level difference : 0m.
- ★2 Indoor temp. : 27°CDB, 19.0°CWB / outdoor temp. : 35°CDB / Equivalent piping length : 7.5m, level difference : 0m.
- ★3 Indoor temp. : 20°CDB / outdoor temp. : 7°CDB, 6°CWB / Equivalent piping length : 7.5m, level difference : 0m.

Conversion Formulae
kcal/h=kW×860
Btu/h=kW×3412
cfm=m ³ /min×35.3

Model Name		RQYQ16PY1B	
★1 Cooling Capacity (19.5°CWB)	kcal / h	39,000	
	Btu / h	155,000	
	kW	45.3	
★2 Cooling Capacity (19.0°CWB)	kW	45.0	
★3 Heating Capacity	kcal / h	43,000	
	Btu / h	171,000	
	kW	50.0	
Casing Colour		Ivory White (5Y7.5/1)	
Dimensions: (H×W×D)		mm	1680×1240×765
Heat Exchanger		Cross Fin Coil	
Comp.	Type		Hermetically Sealed Scroll Type
	Displacement	m³/h	13.34+10.53+10.53
	Number of Revolutions	r/min	6300, 2900, 2900
	Motor Output×Number of Units	kW	(2.7+4.5+4.5)×1
	Starting Method		Soft Start
Fan	Type		Propeller Fan
	Motor Output	kW	0.35×2
	Airflow Rate	m³/min	233
	Drive		Direct Drive
Connecting Pipes	Liquid Pipe	mm	φ12.7 (Brazing Connection)
	Gas Pipe	mm	φ28.6 (Brazing Connection)
Product Mass (Machine Weight)		kg	381
Safety Devices		High Pressure Switch, Fan Driver Overload Protector, Overcurrent Relay, Inverter Overload Protector	
Defrost Method		Deicer	
Capacity Control		%	10~100
Refrigerant	Refrigerant Name		R-410A
	Charge	kg	11.7
	Control		Electronic Expansion Valve
Refrigerator Oil		Refer to the nameplate of compressor	
Standard Accessories		Installation Manual, Operation Manual, Connection Pipes, Clamps	
Drawing No.		4D070264	

Note:

- ★1 Indoor temp. : 27°CDB, 19.5°CWB / outdoor temp. : 35°CDB / Equivalent piping length : 7.5m, level difference : 0m.
- ★2 Indoor temp. : 27°CDB, 19.0°CWB / outdoor temp. : 35°CDB / Equivalent piping length : 7.5m, level difference : 0m.
- ★3 Indoor temp. : 20°CDB / outdoor temp. : 7°CDB, 6°CWB / Equivalent piping length : 7.5m, level difference : 0m.

Conversion Formulae
kcal/h=kW×860 Btu/h=kW×3412 cfm=m³/min×35.3

Model Name (Combination Unit)		RQYQ18PY1B		RQYQ20PY1B		
Model Name (Independent Unit)		RQYQ8PY1B+RQYQ10PY1B		RQYQ8PY1B+RQYQ12PY1B		
★1 Cooling Capacity (19.5°CWB)	kcal / h	43,600		48,300		
	Btu / h	173,000		192,000		
	kW	50.7		56.2		
★2 Cooling Capacity (19.0°CWB)	kW	50.4		55.9		
★3 Heating Capacity	kcal / h	48,600		53,800		
	Btu / h	193,000		213,000		
	kW	56.5		62.5		
Casing Colour		Ivory White (5Y7.5/1)		Ivory White (5Y7.5/1)		
Dimensions: (H×W×D)		mm	(1680×930×765)+(1680×930×765)		(1680×930×765)+(1680×930×765)	
Heat Exchanger		Cross Fin Coil		Cross Fin Coil		
Comp.	Type		Hermetically Sealed Scroll Type		Hermetically Sealed Scroll Type	
	Displacement	m³/h	(16.90)+(13.34+10.53)		(16.90)+(13.34+10.53)	
	Number of Revolutions	r/min	(7980)+(6300, 2900)		(7980)+(6300, 2900)	
	Motor Output×Number of Units	kW	(4.5×1)+(1.4+4.5)×1		(4.5×1)+(3.3+4.5)×1	
	Starting Method		Soft Start		Soft Start	
Fan	Type		Propeller Fan		Propeller Fan	
	Motor Output	kW	(0.75×1)+(0.75×1)		(0.75×1)+(0.75×1)	
	Airflow Rate	m³/min	180+185		180+200	
	Drive		Direct Drive		Direct Drive	
Connecting Pipes	Liquid Pipe	mm	φ15.9 (Brazing Connection)		φ15.9 (Brazing Connection)	
	Gas Pipe	mm	φ28.6 (Brazing Connection)		φ28.6 (Brazing Connection)	
Product Mass (Machine Weight)		kg	230+284		230+284	
Safety Devices		High Pressure Switch, Fan Driver Overload Protector, Overcurrent Relay, Inverter Overload Protector		High Pressure Switch, Fan Driver Overload Protector, Overcurrent Relay, Inverter Overload Protector		
Defrost Method		Deicer		Deicer		
Capacity Control		%	9~100		8~100	
Refrigerant	Refrigerant Name		R-410A		R-410A	
	Charge	kg	10.8+11.7		10.8+11.7	
	Control		Electronic Expansion Valve		Electronic Expansion Valve	
Refrigerator Oil		Refer to the nameplate of compressor		Refer to the nameplate of compressor		
Standard Accessories		Installation Manual, Operation Manual, Connection Pipes, Clamps		Installation Manual, Operation Manual, Connection Pipes, Clamps		
Drawing No.		—		—		

Note:

- ★1 Indoor temp. : 27°CDB, 19.5°CWB / outdoor temp. : 35°CDB / Equivalent piping length : 7.5m, level difference : 0m.
- ★2 Indoor temp. : 27°CDB, 19.0°CWB / outdoor temp. : 35°CDB / Equivalent piping length : 7.5m, level difference : 0m.
- ★3 Indoor temp. : 20°CDB / outdoor temp. : 7°CDB, 6°CWB / Equivalent piping length : 7.5m, level difference : 0m.

Conversion Formulae
kcal/h=kW×860
Btu/h=kW×3412
cfm=m³/min×35.3

Model Name (Combination Unit)		RQYQ22PY1B		RQYQ24PY1B		
Model Name (Independent Unit)		RQYQ10PY1B+RQYQ12PY1B		RQYQ12PY1B+RQYQ12PY1B		
★1 Cooling Capacity (19.5°CWB)	kcal / h	53,200		58,000		
	Btu / h	211,000		230,000		
	kW	61.9		67.4		
★2 Cooling Capacity (19.0°CWB)	kW	61.5		67.0		
★3 Heating Capacity	kcal / h	59,300		64,500		
	Btu / h	235,000		256,000		
	kW	69.0		75.0		
Casing Colour		Ivory White (5Y7.5/1)		Ivory White (5Y7.5/1)		
Dimensions: (HxWxD)		mm	(1680x930x765)+(1680x930x765)		(1680x930x765)+(1680x930x765)	
Heat Exchanger		Cross Fin Coil		Cross Fin Coil		
Comp.	Type		Hermetically Sealed Scroll Type		Hermetically Sealed Scroll Type	
	Displacement	m³/h	(13.34+10.53)+(13.34+10.53)		(13.34+10.53)+(13.34+10.53)	
	Number of Revolutions	r/min	(6300, 2900)+(6300, 2900)		(6300, 2900)+(6300, 2900)	
	Motor OutputxNumber of Units	kW	((1.4+4.5)x1)+((3.3+4.5)x1)		((3.3+4.5)x1)+((3.3+4.5)x1)	
	Starting Method		Soft Start		Soft Start	
Fan	Type		Propeller Fan		Propeller Fan	
	Motor Output	kW	(0.75x1)+(0.75x1)		(0.75x1)+(0.75x1)	
	Airflow Rate	m³/min	185+200		200+200	
	Drive		Direct Drive		Direct Drive	
Connecting Pipes	Liquid Pipe	mm	φ15.9 (Brazing Connection)		φ15.9 (Brazing Connection)	
	Gas Pipe	mm	φ28.6 (Brazing Connection)		φ34.9 (Brazing Connection)	
Product Mass (Machine Weight)		kg	284+284		284+284	
Safety Devices		High Pressure Switch, Fan Driver Overload Protector, Overcurrent Relay, Inverter Overload Protector		High Pressure Switch, Fan Driver Overload Protector, Overcurrent Relay, Inverter Overload Protector		
Defrost Method		Deicer		Deicer		
Capacity Control		%	7~100		6~100	
Refrigerant	Refrigerant Name		R-410A		R-410A	
	Charge	kg	11.7+11.7		11.7+11.7	
	Control		Electronic Expansion Valve		Electronic Expansion Valve	
Refrigerator Oil		Refer to the nameplate of compressor		Refer to the nameplate of compressor		
Standard Accessories		Installation Manual, Operation Manual, Connection Pipes, Clamps		Installation Manual, Operation Manual, Connection Pipes, Clamps		
Drawing No.		—		—		

Note:

- ★1 Indoor temp. : 27°CDB, 19.5°CWB / outdoor temp. : 35°CDB / Equivalent piping length : 7.5m, level difference : 0m.
- ★2 Indoor temp. : 27°CDB, 19.0°CWB / outdoor temp. : 35°CDB / Equivalent piping length : 7.5m, level difference : 0m.
- ★3 Indoor temp. : 20°CDB / outdoor temp. : 7°CDB, 6°CWB / Equivalent piping length : 7.5m, level difference : 0m.

Conversion Formulae
kcal/h=kWx860
Btu/h=kWx3412
cfm=m³/minx35.3

Model Name (Combination Unit)		RQYQ26PY1B		RQYQ28PY1B		
Model Name (Independent Unit)		RQYQ10PY1B+RQYQ16PY1B		RQYQ12PY1B+RQYQ16PY1B		
★1 Cooling Capacity (19.5°CWB)	kcal / h	63,300		67,900		
	Btu / h	251,000		270,000		
	kW	73.5		79.0		
★2 Cooling Capacity (19.0°CWB)	kW	73.0		78.5		
★3 Heating Capacity	kcal / h	70,100		75,300		
	Btu / h	278,000		299,000		
	kW	81.5		87.5		
Casing Colour		Ivory White (5Y7.5/1)		Ivory White (5Y7.5/1)		
Dimensions: (H×W×D)		mm	(1680×930×765)+(1680×1240×765)		(1680×930×765)+(1680×1240×765)	
Heat Exchanger		Cross Fin Coil		Cross Fin Coil		
Comp.	Type		Hermetically Sealed Scroll Type		Hermetically Sealed Scroll Type	
	Displacement	m³/h	(13.34+10.53)+(13.34+10.53+10.53)		(13.34+10.53)+(13.34+10.53+10.53)	
	Number of Revolutions	r/min	(6300, 2900)+(6300, 2900, 2900)		(6300, 2900)+(6300, 2900, 2900)	
	Motor Output×Number of Units	kW	((1.4+4.5)×1)+(2.7+4.5+4.5)×1)		((3.3+4.5)×1)+((2.7+4.5+4.5)×1)	
	Starting Method		Soft Start		Soft Start	
Fan	Type		Propeller Fan		Propeller Fan	
	Motor Output	kW	(0.75×1)+(0.35×2)		(0.75×1)+(0.35×2)	
	Airflow Rate	m³/min	185+233		200+233	
	Drive		Direct Drive		Direct Drive	
Connecting Pipes	Liquid Pipe	mm	φ19.1 (Brazing Connection)		φ19.1 (Brazing Connection)	
	Gas Pipe	mm	φ34.9 (Brazing Connection)		φ34.9 (Brazing Connection)	
Product Mass (Machine Weight)		kg	284+381		284+381	
Safety Devices		High Pressure Switch, Fan Driver Overload Protector, Overcurrent Relay, Inverter Overload Protector		High Pressure Switch, Fan Driver Overload Protector, Overcurrent Relay, Inverter Overload Protector		
Defrost Method		Deicer		Deicer		
Capacity Control		%	6~100		5~100	
Refrigerant	Refrigerant Name		R-410A		R-410A	
	Charge	kg	11.7+11.7		11.7+11.7	
	Control		Electronic Expansion Valve		Electronic Expansion Valve	
Refrigerator Oil		Refer to the nameplate of compressor		Refer to the nameplate of compressor		
Standard Accessories		Installation Manual, Operation Manual, Connection Pipes, Clamps		Installation Manual, Operation Manual, Connection Pipes, Clamps		
Drawing No.		—		—		

Note:

- ★1 Indoor temp. : 27°CDB, 19.5°CWB / outdoor temp. : 35°CDB / Equivalent piping length : 7.5m, level difference : 0m.
- ★2 Indoor temp. : 27°CDB, 19.0°CWB / outdoor temp. : 35°CDB / Equivalent piping length : 7.5m, level difference : 0m.
- ★3 Indoor temp. : 20°CDB / outdoor temp. : 7°CDB, 6°CWB / Equivalent piping length : 7.5m, level difference : 0m.

Conversion Formulae
kcal/h=kW×860
Btu/h=kW×3412
cfm=m³/min×35.3

Model Name (Combination Unit)		RQYQ30PY1B		RQYQ32PY1B		
Model Name (Independent Unit)		RQYQ14PY1B+RQYQ16PY1B		RQYQ16PY1B+RQYQ16PY1B		
★1 Cooling Capacity (19.5°CWB)	kcal / h	73,500		78,000		
	Btu / h	292,000		310,000		
	kW	85.5		90.6		
★2 Cooling Capacity (19.0°CWB)	kW	85.0		90.0		
★3 Heating Capacity	kcal / h	81,700		86,000		
	Btu / h	324,000		341,000		
	kW	95.0		100		
Casing Colour		Ivory White (5Y7.5/1)		Ivory White (5Y7.5/1)		
Dimensions: (H×W×D)		mm	(1680×1240×765)+(1680×1240×765)		(1680×1240×765)+(1680×1240×765)	
Heat Exchanger		Cross Fin Coil		Cross Fin Coil		
Comp.	Type		Hermetically Sealed Scroll Type		Hermetically Sealed Scroll Type	
	Displacement	m³/h	(13.34+10.53+10.53)+(13.34+10.53+10.53)		(13.34+10.53+10.53)+(13.34+10.53+10.53)	
	Number of Revolutions	r/min	(6300, 2900, 2900)+(6300, 2900, 2900)		(6300, 2900, 2900)+(6300, 2900, 2900)	
	Motor Output×Number of Units	kW	((1.6+4.5+4.5)×1)+((2.7+4.5+4.5)×1)		((2.7+4.5+4.5)×1)+((2.7+4.5+4.5)×1)	
	Starting Method		Soft Start		Soft Start	
Fan	Type		Propeller Fan		Propeller Fan	
	Motor Output	kW	(0.35×2)+(0.35×2)		(0.35×2)+(0.35×2)	
	Airflow Rate	m³/min	233+233		233+233	
	Drive		Direct Drive		Direct Drive	
Connecting Pipes	Liquid Pipe	mm	φ19.1 (Brazing Connection)		φ19.1 (Brazing Connection)	
	Gas Pipe	mm	φ34.9 (Brazing Connection)		φ34.9 (Brazing Connection)	
Product Mass (Machine Weight)		kg	381+381		381+381	
Safety Devices		High Pressure Switch, Fan Driver Overload Protector, Overcurrent Relay, Inverter Overload Protector		High Pressure Switch, Fan Driver Overload Protector, Overcurrent Relay, Inverter Overload Protector		
Defrost Method		Deicer		Deicer		
Capacity Control		%	5~100		5~100	
Refrigerant	Refrigerant Name		R-410A		R-410A	
	Charge	kg	11.7+11.7		11.7+11.7	
	Control		Electronic Expansion Valve		Electronic Expansion Valve	
Refrigerator Oil		Refer to the nameplate of compressor		Refer to the nameplate of compressor		
Standard Accessories		Installation Manual, Operation Manual, Connection Pipes, Clamps		Installation Manual, Operation Manual, Connection Pipes, Clamps		
Drawing No.		—		—		

Note:

- ★1 Indoor temp. : 27°CDB, 19.5°CWB / outdoor temp. : 35°CDB / Equivalent piping length : 7.5m, level difference : 0m.
- ★2 Indoor temp. : 27°CDB, 19.0°CWB / outdoor temp. : 35°CDB / Equivalent piping length : 7.5m, level difference : 0m.
- ★3 Indoor temp. : 20°CDB / outdoor temp. : 7°CDB, 6°CWB / Equivalent piping length : 7.5m, level difference : 0m.

Conversion Formulae
kcal/h=kW×860
Btu/h=kW×3412
cfm=m³/min×35.3

Model Name (Combination Unit)		RQYQ34PY1B		RQYQ36PY1B		
Model Name (Independent Unit)		RQYQ10PY1B+RQYQ10PY1B+RQYQ14PY1B		RQYQ10PY1B+RQYQ10PY1B+RQYQ16PY1B		
★1 Cooling Capacity (19.5°CWB)	kcal / h	83,200		87,700		
	Btu / h	329,000		348,000		
	kW	96.6		102		
★2 Cooling Capacity (19.0°CWB)	kW	96.0		101		
★3 Heating Capacity	kcal / h	92,700		97,200		
	Btu / h	368,000		386,000		
	kW	108		113		
Casing Colour		Ivory White (5Y7.5/1)		Ivory White (5Y7.5/1)		
Dimensions: (H×W×D)		mm	(1680×930×765)+(1680×930×765)+(1680×1240×765)		(1680×930×765)+(1680×930×765)+(1680×1240×765)	
Heat Exchanger		Cross Fin Coil		Cross Fin Coil		
Comp.	Type		Hermetically Sealed Scroll Type		Hermetically Sealed Scroll Type	
	Displacement	m³/h	(13.34+10.53)+(13.34+10.53)+(13.34+10.53+10.53)		(13.34+10.53)+(13.34+10.53)+(13.34+10.53+10.53)	
	Number of Revolutions	r/min	(6300, 2900)+(6300, 2900)+(6300, 2900, 2900)		(6300, 2900)+(6300, 2900)+(6300, 2900, 2900)	
	Motor Output×Number of Units	kW	((1.4+4.5)×1)+((1.4+4.5)×1)+((1.6+4.5+4.5)×1)		((1.4+4.5)×1)+((1.4+4.5)×1)+((2.7+4.5+4.5)×1)	
	Starting Method		Soft Start		Soft Start	
Fan	Type		Propeller Fan		Propeller Fan	
	Motor Output	kW	(0.75×1)+(0.75×1)+(0.35×2)		(0.75×1)+(0.75×1)+(0.35×2)	
	Airflow Rate	m³/min	185+185+233		185+185+233	
	Drive		Direct Drive		Direct Drive	
Connecting Pipes	Liquid Pipe	mm	φ19.1 (Brazing Connection)		φ19.1 (Brazing Connection)	
	Gas Pipe	mm	φ34.9 (Brazing Connection)		φ41.3 (Brazing Connection)	
Product Mass (Machine Weight)		kg	284+284+381		284+284+381	
Safety Devices		High Pressure Switch, Fan Driver Overload Protector, Overcurrent Relay, Inverter Overload Protector		High Pressure Switch, Fan Driver Overload Protector, Overcurrent Relay, Inverter Overload Protector		
Defrost Method		Deicer		Deicer		
Capacity Control		%	5~100		4~100	
Refrigerant	Refrigerant Name		R-410A		R-410A	
	Charge	kg	11.7+11.7+11.7		11.7+11.7+11.7	
	Control		Electronic Expansion Valve		Electronic Expansion Valve	
Refrigerator Oil		Refer to the nameplate of compressor		Refer to the nameplate of compressor		
Standard Accessories		Installation Manual, Operation Manual, Connection Pipes, Clamps		Installation Manual, Operation Manual, Connection Pipes, Clamps		
Drawing No.		—		—		

Note:

- ★1 Indoor temp. : 27°CDB, 19.5°CWB / outdoor temp. : 35°CDB / Equivalent piping length : 7.5m, level difference : 0m.
- ★2 Indoor temp. : 27°CDB, 19.0°CWB / outdoor temp. : 35°CDB / Equivalent piping length : 7.5m, level difference : 0m.
- ★3 Indoor temp. : 20°CDB / outdoor temp. : 7°CDB, 6°CWB / Equivalent piping length : 7.5m, level difference : 0m.

Conversion Formulae
kcal/h=kW×860
Btu/h=kW×3412
cfm=m³/min×35.3

Model Name (Combination Unit)		RQYQ38PY1B		RQYQ40PY1B		
Model Name (Independent Unit)		RQYQ10PY1B+RQYQ12PY1B+RQYQ16PY1B		RQYQ12PY1B+RQYQ12PY1B+RQYQ16PY1B		
★1 Cooling Capacity (19.5°CWB)	kcal / h	92,900		97,200		
	Btu / h	368,000		386,000		
	kW	108		113		
★2 Cooling Capacity (19.0°CWB)	kW	107		112		
★3 Heating Capacity	kcal / h	102,000		108,000		
	Btu / h	406,000		427,000		
	kW	119		125		
Casing Colour		Ivory White (5Y7.5/1)		Ivory White (5Y7.5/1)		
Dimensions: (HxWxD)		mm	(1680x930x765)+(1680x930x765)+(1680x1240x765)		(1680x930x765)+(1680x930x765)+(1680x1240x765)	
Heat Exchanger		Cross Fin Coil		Cross Fin Coil		
Comp.	Type		Hermetically Sealed Scroll Type		Hermetically Sealed Scroll Type	
	Displacement	m³/h	(13.34+10.53)+(13.34+10.53)+(13.34+10.53+10.53)		(13.34+10.53)+(13.34+10.53)+(13.34+10.53+10.53)	
	Number of Revolutions	r/min	(6300, 2900)+(6300, 2900)+(6300, 2900, 2900)		(6300, 2900)+(6300, 2900)+(6300, 2900, 2900)	
	Motor OutputxNumber of Units	kW	((1.4+4.5)x1)+(3.3+4.5)x1)+(2.7+4.5+4.5)x1		((3.3+4.5)x1)+(3.3+4.5)x1)+(2.7+4.5+4.5)x1	
	Starting Method		Soft Start		Soft Start	
Fan	Type		Propeller Fan		Propeller Fan	
	Motor Output	kW	(0.75x1)+(0.75x1)+(0.35x2)		(0.75x1)+(0.75x1)+(0.35x2)	
	Airflow Rate	m³/min	185+200+233		200+200+233	
	Drive		Direct Drive		Direct Drive	
Connecting Pipes	Liquid Pipe	mm	φ19.1 (Brazing Connection)		φ19.1 (Brazing Connection)	
	Gas Pipe	mm	φ41.3 (Brazing Connection)		φ41.3 (Brazing Connection)	
Product Mass (Machine Weight)		kg	284+284+381		284+284+381	
Safety Devices		High Pressure Switch, Fan Driver Overload Protector, Overcurrent Relay, Inverter Overload Protector		High Pressure Switch, Fan Driver Overload Protector, Overcurrent Relay, Inverter Overload Protector		
Defrost Method		Deicer		Deicer		
Capacity Control		%	4~100		4~100	
Refrigerant	Refrigerant Name		R-410A		R-410A	
	Charge	kg	11.7+11.7+11.7		11.7+11.7+11.7	
	Control		Electronic Expansion Valve		Electronic Expansion Valve	
Refrigerator Oil		Refer to the nameplate of compressor		Refer to the nameplate of compressor		
Standard Accessories		Installation Manual, Operation Manual, Connection Pipes, Clamps		Installation Manual, Operation Manual, Connection Pipes, Clamps		
Drawing No.		—		—		

Note:

- ★1 Indoor temp. : 27°CDB, 19.5°CWB / outdoor temp. : 35°CDB / Equivalent piping length : 7.5m, level difference : 0m.
- ★2 Indoor temp. : 27°CDB, 19.0°CWB / outdoor temp. : 35°CDB / Equivalent piping length : 7.5m, level difference : 0m.
- ★3 Indoor temp. : 20°CDB / outdoor temp. : 7°CDB, 6°CWB / Equivalent piping length : 7.5m, level difference : 0m.

Conversion Formulae
kcal/h=kWx860
Btu/h=kWx3412
cfm=m³/minx35.3

Model Name (Combination Unit)		RQYQ42PY1B		RQYQ44PY1B	
Model Name (Independent Unit)		RQYQ10PY1B+RQYQ16PY1B+RQYQ16PY1B		RQYQ12PY1B+RQYQ16PY1B+RQYQ16PY1B	
★1 Cooling Capacity (19.5°CWB)	kcal / h	102,000		108,000	
	Btu / h	406,000		427,000	
	kW	119		125	
★2 Cooling Capacity (19.0°CWB)	kW	118		124	
★3 Heating Capacity	kcal / h	114,000		119,000	
	Btu / h	450,000		471,000	
	kW	132		138	
Casing Colour		Ivory White (5Y7.5/1)		Ivory White (5Y7.5/1)	
Dimensions: (H×W×D)		mm	(1680×930×765)+(1680×1240×765)+(1680×1240×765)		(1680×930×765)+(1680×1240×765)+(1680×1240×765)
Heat Exchanger		Cross Fin Coil		Cross Fin Coil	
Comp.	Type	Hermetically Sealed Scroll Type		Hermetically Sealed Scroll Type	
	Displacement	m ³ /h	(13.34+10.53)+(13.34+10.53+10.53)+(13.34+10.53+10.53)		(13.34+10.53)+(13.34+10.53+10.53)+(13.34+10.53+10.53)
	Number of Revolutions	r/min	(6300, 2900)+(6300, 2900, 2900)+(6300, 2900, 2900)		(6300, 2900)+(6300, 2900, 2900)+(6300, 2900, 2900)
	Motor Output×Number of Units	kW	((1.4+4.5)×1)+((2.7+4.5+4.5)×1)+((2.7+4.5+4.5)×1)		((3.3+4.5)×1)+((2.7+4.5+4.5)×1)+((2.7+4.5+4.5)×1)
	Starting Method	Soft Start		Soft Start	
Fan	Type	Propeller Fan		Propeller Fan	
	Motor Output	kW	(0.75×1)+(0.35×2)+(0.35×2)		(0.75×1)+(0.35×2)+(0.35×2)
	Airflow Rate	m ³ /min	185+233+233		200+233+233
	Drive	Direct Drive		Direct Drive	
Connecting Pipes	Liquid Pipe	mm	φ19.1 (Brazing Connection)		φ19.1 (Brazing Connection)
	Gas Pipe	mm	φ41.3 (Brazing Connection)		φ41.3 (Brazing Connection)
Product Mass (Machine Weight)		kg	284+381+381		284+381+381
Safety Devices		High Pressure Switch, Fan Driver Overload Protector, Overcurrent Relay, Inverter Overload Protector		High Pressure Switch, Fan Driver Overload Protector, Overcurrent Relay, Inverter Overload Protector	
Defrost Method		Deicer		Deicer	
Capacity Control		%	4~100		4~100
Refrigerant	Refrigerant Name		R-410A		R-410A
	Charge	kg	11.7+11.7+11.7		11.7+11.7+11.7
	Control		Electronic Expansion Valve		Electronic Expansion Valve
Refrigerator Oil		Refer to the nameplate of compressor		Refer to the nameplate of compressor	
Standard Accessories		Installation Manual, Operation Manual, Connection Pipes, Clamps		Installation Manual, Operation Manual, Connection Pipes, Clamps	
Drawing No.		—		—	

Note:

- ★1 Indoor temp. : 27°CDB, 19.5°CWB / outdoor temp. : 35°CDB / Equivalent piping length : 7.5m, level difference : 0m.
- ★2 Indoor temp. : 27°CDB, 19.0°CWB / outdoor temp. : 35°CDB / Equivalent piping length : 7.5m, level difference : 0m.
- ★3 Indoor temp. : 20°CDB / outdoor temp. : 7°CDB, 6°CWB / Equivalent piping length : 7.5m, level difference : 0m.

Conversion Formulae
kcal/h=kW×860
Btu/h=kW×3412
cfm=m ³ /min×35.3

Model Name (Combination Unit)		RQYQ46PY1B		RQYQ48PY1B		
Model Name (Independent Unit)		RQYQ14PY1B+RQYQ16PY1B+RQYQ16PY1B		RQYQ16PY1B+RQYQ16PY1B+RQYQ16PY1B		
★1 Cooling Capacity (19.5°CWB)	kcal / h	113,000		117,000		
	Btu / h	447,000		464,000		
	kW	131		136		
★2 Cooling Capacity (19.0°CWB)	kW	130		135		
★3 Heating Capacity	kcal / h	125,000		129,000		
	Btu / h	495,000		521,000		
	kW	145		150		
Casing Colour		Ivory White (5Y7.5/1)		Ivory White (5Y7.5/1)		
Dimensions: (HxWxD)		mm	(1680x1240x765)+(1680x1240x765)+(1680x1240x765)		(1680x1240x765)+(1680x1240x765)+(1680x1240x765)	
Heat Exchanger		Cross Fin Coil		Cross Fin Coil		
Comp.	Type		Hermetically Sealed Scroll Type		Hermetically Sealed Scroll Type	
	Displacement	m³/h	(13.34+10.53+10.53)+(13.34+10.53+10.53)+(13.34+10.53+10.53)		(13.34+10.53+10.53)+(13.34+10.53+10.53)+(13.34+10.53+10.53)	
	Number of Revolutions	r/min	(6300, 2900, 2900)+(6300, 2900, 2900)+(6300, 2900, 2900)		(6300, 2900, 2900)+(6300, 2900, 2900)+(6300, 2900, 2900)	
	Motor OutputxNumber of Units	kW	((1.6+4.5+4.5)×1)+((2.7+4.5+4.5)×1)+((2.7+4.5+4.5)×1)		((2.7+4.5+4.5)×1)+((2.7+4.5+4.5)×1)+((2.7+4.5+4.5)×1)	
	Starting Method		Soft Start		Soft Start	
Fan	Type		Propeller Fan		Propeller Fan	
	Motor Output	kW	(0.35x2)+(0.35x2)+(0.35x2)		(0.35x2)+(0.35x2)+(0.35x2)	
	Airflow Rate	m³/min	233+233+233		233+233+233	
	Drive		Direct Drive		Direct Drive	
Connecting Pipes	Liquid Pipe	mm	φ19.1 (Brazing Connection)		φ19.1 (Brazing Connection)	
	Gas Pipe	mm	φ41.3 (Brazing Connection)		φ41.3 (Brazing Connection)	
Product Mass (Machine Weight)		kg	381+381+381		381+381+381	
Safety Devices		High Pressure Switch, Fan Driver Overload Protector, Overcurrent Relay, Inverter Overload Protector		High Pressure Switch, Fan Driver Overload Protector, Overcurrent Relay, Inverter Overload Protector		
Defrost Method		Deicer		Deicer		
Capacity Control		%	3~100		3~100	
Refrigerant	Refrigerant Name		R-410A		R-410A	
	Charge	kg	11.7+11.7+11.7		11.7+11.7+11.7	
	Control		Electronic Expansion Valve		Electronic Expansion Valve	
Refrigerator Oil		Refer to the nameplate of compressor		Refer to the nameplate of compressor		
Standard Accessories		Installation Manual, Operation Manual, Connection Pipes, Clamps		Installation Manual, Operation Manual, Connection Pipes, Clamps		
Drawing No.		—		—		

Note:

- ★1 Indoor temp. : 27°CDB, 19.5°CWB / outdoor temp. : 35°CDB / Equivalent piping length : 7.5m, level difference : 0m.
- ★2 Indoor temp. : 27°CDB, 19.0°CWB / outdoor temp. : 35°CDB / Equivalent piping length : 7.5m, level difference : 0m.
- ★3 Indoor temp. : 20°CDB / outdoor temp. : 7°CDB, 6°CWB / Equivalent piping length : 7.5m, level difference : 0m.

Conversion Formulae
kcal/h=kWx860
Btu/h=kWx3412
cfm=m³/minx35.3

Part 3

Refrigerant Circuit

1. Refrigerant Circuit	30
1.1 RQYQ8PY1B.....	30
1.2 RQYQ10-12PY1B.....	32
1.3 RQYQ14-16PY1B.....	34
2. Functional Parts Layout	36
2.1 RQYQ8PY1B.....	36
2.2 RQYQ10-12PY1B.....	37
2.3 RQYQ14-16PY1B.....	38
3. Refrigerant Flow for Each Operation Mode.....	39
3.1 RQYQ8~16PY1B	39

1. Refrigerant Circuit

1.1 RQYQ8PY1B

No. in refrigerant system diagram	Symbol	Name	Major Function
(1)	M1C	Inverter compressor (INV.)	Inverter compressor is operated on frequencies 52Hz to 266Hz by using the inverter. The number of operating steps is 24.
(2)	M1F	Inverter fan	Because the system is an air heat exchange type, the fan is operated 8-step rotation speed by using the inverter.
(3)	Y1E	Electronic expansion valve (Main)	While in heating operation, PI control is applied to keep the outlet superheated degree of air heat exchanger constant.
(4)	Y2E	Electronic expansion valve (Subcooling)	PI control is applied to keep the outlet superheated degree of subcooling heat exchanger constant.
(5)	Y1S	Solenoid valve (Hot gas)	Used to prevent the low pressure from transient falling.
(6)	Y2S	Solenoid valve (Bypass)	Used to bypass the mixing unit during the normal operation.
(7)	Y3S	Four way valve (Heat exchanger)	Used to switch the operation mode between cooling and heating.
(8)	Y4S	Solenoid valve (Mixing unit inlet)	Use to adjust the amount of refrigeration oil and clean pipes during check operation. Use to prevent refrigerant from flowing into the mixing unit during normal operation.
(9)	Y5S	Solenoid valve (Circuit of oil return)	Used to adjust the amount of oil in the mixing unit.
(10)	Y6S	Solenoid valve (Close liquid pipe for stopped outdoor unit)	Used to prevent the accumulation of refrigerant in the non-operating outdoor units in a multi-outdoor-unit system.
(11)	Y7S	Solenoid valve (Receiver liquid level)	Used to detect the amount of refrigerant.
(12)	Y8S	Solenoid valve (Receiver gas vent)	Used to collect refrigerant to the receiver.
(13)	Y9S	Solenoid valve (Oil regulator outlet)	Used to adjust the refrigeration oil during the check operation.
(14)	Y10S	Solenoid valve (Main electronic expansion valve bypass)	Used to prevent an increase in the liquid pipe pressure during cooling operation.
(15)	Y11S	Solenoid valve (Refrigerant regulator gas vent pipe)	Used to collect refrigerant to the refrigerant regulator.
(16)	Y12S	Solenoid valve (Refrigerant regulator liquid pipe)	Used to collect refrigerant to the refrigerant regulator.
(17)	Y13S	Solenoid valve (Refrigerant regulator gas pipe)	Used to discharge refrigerant from the refrigerant regulator.
(18)	Y14S	Solenoid valve (Refrigerant regulator liquid outlet)	Used to discharge refrigerant from the refrigerant regulator.
(19)	S1NPH	High pressure sensor	Used to detect high pressure.
(20)	S2NPH	High pressure sensor (Liquid pipe outlet)	Used to detect pressure of liquid pipe.
(21)	S1NPL	Low pressure sensor	Used to detect low pressure.
(22)	S1PH	High pressure switch (For INV.)	In order to prevent the increase of high pressure when a malfunction occurs, this switch is activated at high pressure of 4.0 MPa or more to stop the compressor operation.
(23)	S2PH	High pressure switch (for control)	In order to prevent the increase of field piping pressure when a malfunction occurs, this switch is activated at pressure of 3.3 MPa or more to stop the compressor operation.
(24)	-	Subcooling heat exchanger	Apply subcooling to liquid refrigerant.
(25)	-	Pipe heat exchanger (A)	Heats the refrigerant that flows out of the receiver.
(26)	-	Pipe heat exchanger (B)	
(27)	-	Fusible plug	The fusible part fuses at a temperature of 70 to 75°C, allow pressure to escape to the atmosphere. This is in order to prevent the pressure rise in case of a fire or other abnormal heating.
(28)	-		
(29)	-	Pressure regulating valve 1 (Liquid pipe - Suction pipe)	Open at 4.0 MPa or more to avoid pressure increase to prevent damage to functional parts by the pressure increase and to protect the field piping during transportation and storage.
(30)	-	Pressure regulating valve 2 (Refrigerant regulator - Discharge pipe)	Open at 2 to 2.7 MPa or more to avoid pressure increase to prevent damage to functional parts by the pressure increase and to protect the field piping during transportation and storage.
(31)	R1T	Thermistor (Outdoor air)	Used to detect outdoor temperature, correct discharge pipe temperature and others.
(32)	R2T	Thermistor (Receiver liquid level)	Used to detect the refrigerant temperature at the liquid level detection point of the receiver.
(33)	R3T	Thermistor (M1C discharge pipe)	Used to detect discharge pipe temperature. Used for compressor temperature protection control.
(34)	R4T	Thermistor (Refrigerant regulator liquid pipe)	Detects the liquid pipe temperature of the refrigerant regulator. Used during adjustment of refrigerant amount.
(35)	R5T	Thermistor (Subcooling heat exchanger outlet)	Used to detect the gas pipe temperature on evaporation side of the subcooling heat exchanger, keep the superheated degree at the subcooling heat exchanger constant, and others.
(36)	R6T	Thermistor (Liquid pipe)	Used to detect liquid pipe temperature. Used for purpose such as drift prevention control between heating indoor and outdoor units in multi-outdoor unit systems.
(37)	R7T	Thermistor (Receiver gas vent outlet)	Used to detect the refrigerant temperature at the liquid level detection point of the receiver.
(38)	R8T	Thermistor (Suction pipe)	Used to detect suction pipe temperature. Used for purpose such as control for constant degree of suction superheat during heating.
(39)	R9T	Thermistor (Heat exchanger deicer)	Used to detect liquid pipe temperature of air heat exchanger. Used to make judgements on defrosting operation.

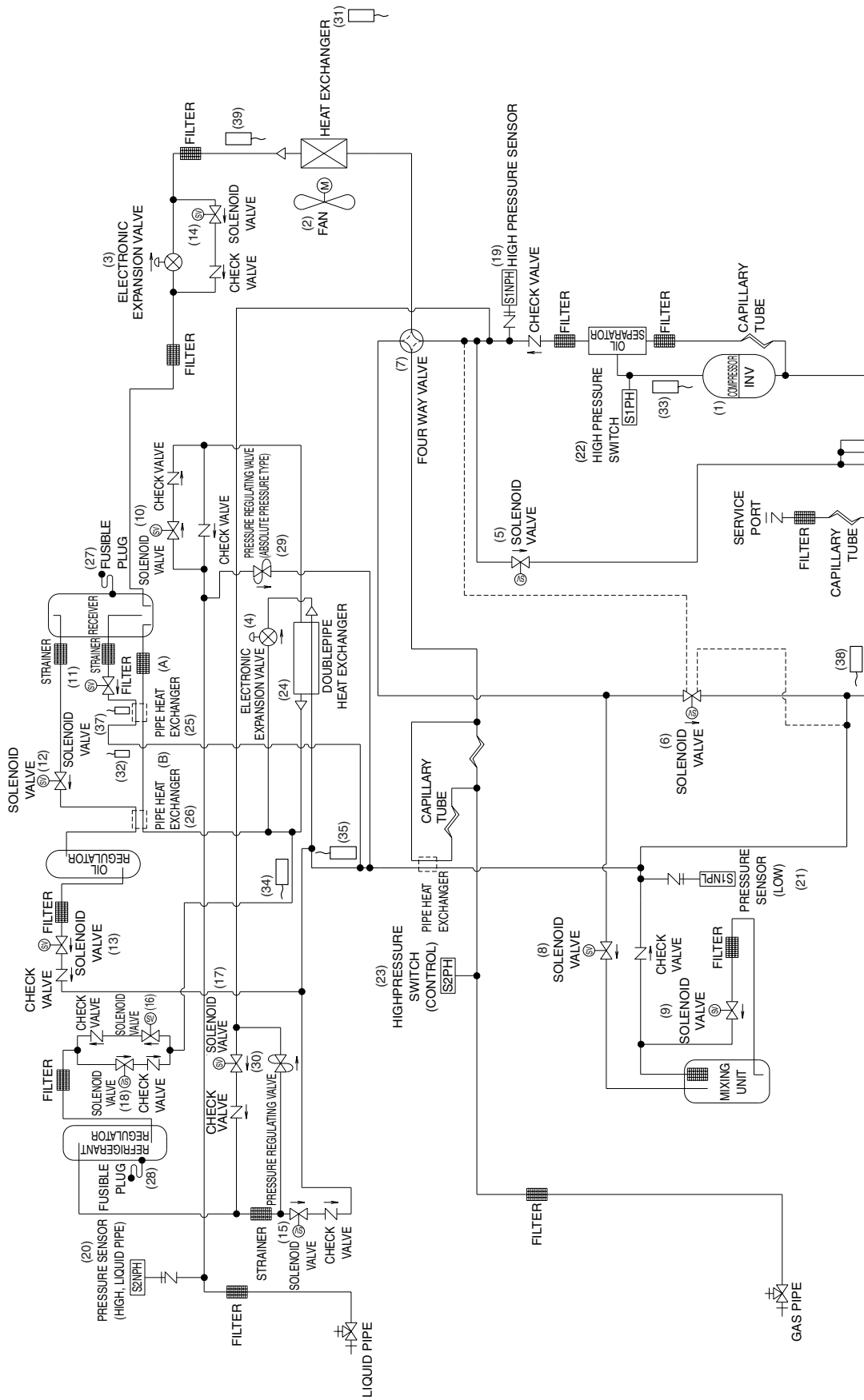

3D069117A

1.2 RQYQ10-12PY1B

No. in refrigerant system diagram	Symbol	Name	Major Function
(1)	M1C	Inverter compressor (INV.)	Inverter compressor is operated on frequencies 52Hz to 210Hz by using the inverter. Standard compressor is operated with commercial power supply only. The number of operating steps is 31 when inverter compressor is operated in combination with standard compressor.
(2)	M2C	Standard compressor 1 (STD1)	
(3)	M1F	Inverter fan	Because the system is an air heat exchange type, the fan is operated 8-step rotation speed by using the inverter.
(4)	Y1E	Electronic expansion valve (Main)	While in heating operation, PI control is applied to keep the outlet superheated degree of air heat exchanger constant.
(5)	Y2E	Electronic expansion valve (Subcooling)	PI control is applied to keep the outlet superheated degree of subcooling heat exchanger constant.
(6)	Y1S	Solenoid valve (Hot gas)	Used to prevent the low pressure from transient falling.
(7)	Y2S	Solenoid valve (Bypass)	Used to bypass the mixing unit during the normal operation.
(8)	Y3S	Four way valve (Heat exchanger)	Used to switch the operation mode between cooling and heating.
(9)	Y4S	Solenoid valve (Mixing unit inlet)	Use to adjust the amount of refrigeration oil and clean pipes during check operation. Use to prevent refrigerant from flowing into the mixing unit during normal operation.
(10)	Y5S	Solenoid valve (Circuit of oil return)	Used to adjust the amount of oil in the mixing unit.
(11)	Y6S	Solenoid valve (Close liquid pipe for stopped outdoor unit)	Used to prevent the accumulation of refrigerant in the non-operating outdoor units in a multi-outdoor-unit system.
(12)	Y7S	Solenoid valve (Receiver liquid level)	Used to detect the amount of refrigerant.
(13)	Y8S	Solenoid valve (Receiver gas vent)	Used to collect refrigerant to the receiver.
(14)	Y9S	Solenoid valve (Oil regulator outlet)	Used to adjust the refrigeration oil during the check operation.
(15)	Y10S	Solenoid valve (Main electronic expansion valve bypass)	Used to prevent the increase of the liquid pipe pressure during cooling operation
(16)	Y11S	Solenoid valve (Refrigerant regulator gas vent pipe)	Used to collect refrigerant to the refrigerant regulator.
(17)	Y12S	Solenoid valve (Refrigerant regulator liquid pipe)	Used to collect refrigerant to the refrigerant regulator.
(18)	Y13S	Solenoid valve (Refrigerant regulator gas pipe)	Used to discharge refrigerant from the refrigerant regulator.
(19)	Y14S	Solenoid valve (Refrigerant regulator liquid outlet)	Used to discharge refrigerant from the refrigerant regulator.
(20)	S1NPH	High pressure sensor	Used to detect high pressure.
(21)	S2NPH	High pressure sensor (Liquid pipe outlet)	Used to detect pressure of liquid pipe.
(22)	S1NPL	Low pressure sensor	Used to detect low pressure.
(23)	S1PH	High pressure switch (For INV.)	In order to prevent the increase of high pressure when an error occurs, this switch is activated at high pressure of 4.0 MPa or more to stop the compressor operation.
(24)	S2PH	High pressure switch (For STD 1.)	
(25)	S3PH	High pressure switch (for control)	In order to prevent the increase of field piping pressure when an error occurs, this switch is activated at pressure of 3.3 MPa or more to stop the compressor operation.
(26)	-	Subcooling heat exchanger	Apply subcooling to liquid refrigerant.
(27)	-	Pipe heat exchanger (A)	
(28)	-	Pipe heat exchanger (B)	
(29)	-	Pipe heat exchanger (C)	
(30)	-	Fusible plug	The fusible part fuses at a temperature of 70 to 75°C, allow pressure to escape to the atmosphere. This is in order to prevent the pressure rise in case of a fire or other abnormal heating.
(31)	-		
(32)	-	Pressure regulating valve 1 (Liquid pipe - Suction pipe)	Open at 4.0 MPa or more to avoid pressure increase to prevent damage to functional parts by the pressure increase and to protect the field piping during transportation and storage.
(33)	-	Pressure regulating valve 2 (Refrigerant regulator - Discharge pipe)	Open at 2 to 2.7 MPa or more to avoid pressure increase to prevent damage to functional parts by the pressure increase and to protect the field piping during transportation and storage.
(34)	R1T	Thermistor (Outdoor air)	Used to detect outdoor temperature, correct discharge pipe temperature and others.
(35)	R2T	Thermistor (Receiver liquid level)	Used to detect the refrigerant temperature at the liquid level detection point of the receiver.
(36)	R31T	Thermistor (M1C discharge pipe)	Used to detect discharge pipe temperature. Used for compressor temperature protection control.
(37)	R32T	Thermistor (M2C discharge pipe)	
(38)	R4T	Thermistor (Refrigerant regulator liquid pipe)	Detects the liquid pipe temperature of the refrigerant regulator. Used during adjustment of refrigerant amount.
(39)	R5T	Thermistor (Subcooling heat exchanger outlet)	Used to detect the gas pipe temperature on evaporation side of the subcooling heat exchanger, keep the superheated degree at the subcooling heat exchanger constant, and others.
(40)	R6T	Thermistor (Liquid pipe)	Used to detect liquid pipe temperature. Used for purpose such as drift prevention control between heating indoor and outdoor units in multi-outdoor unit systems.
(41)	R7T	Thermistor (Receiver gas vent outlet)	Used to detect the refrigerant temperature at the liquid level detection point of the receiver.
(42)	R8T	Thermistor (Suction pipe)	Used to detect suction pipe temperature. Used for purpose such as control for constant degree of suction superheat during heating.
(43)	R9T	Thermistor (Heat exchanger deicer)	Used to detect liquid pipe temperature of air heat exchanger. Used to make judgements on defrosting operation.

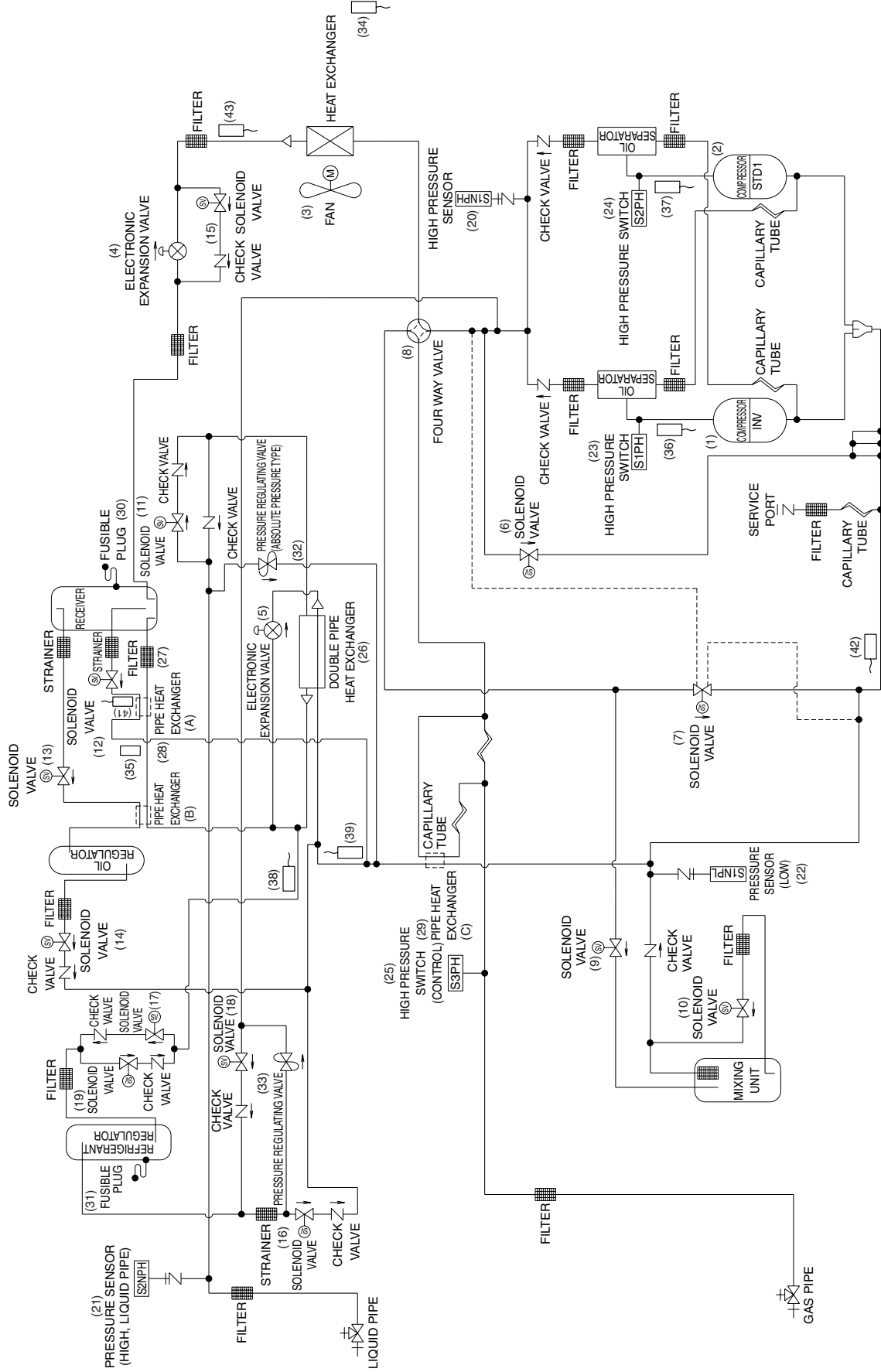

3D069109A

1.3 RQYQ14-16PY1B

No. in refrigerant system diagram	Symbol	Name	Major Function
(1)	M1C	Inverter compressor (INV.)	Inverter compressor is operated on frequencies 52Hz to 210Hz by using the inverter. Standard compressor is operated with commercial power supply only. The number of operating steps is 49 when inverter compressor is operated in combination with standard co
(2)	M2C	Standard compressor 1 (STD1)	
(3)	M3C	Standard compressor 2 (STD2)	
(4)	M1F	Inverter fan	Because the system is an air heat exchange type, the fan is operated 8-step rotation speed by using the inverter.
(5)	M2F		
(6)	Y1E	Electronic expansion valve (Main)	While in heating operation, PI control is applied to keep the outlet superheated degree of air heat exchanger constant.
(7)	Y2E	Electronic expansion valve (Main 2)	
(8)	Y3E	Electronic expansion valve (Subcooling)	PI control is applied to keep the outlet superheated degree of subcooling heat exchanger constant.
(9)	Y1S	Solenoid valve (Hot gas)	Used to prevent the low pressure from transient falling.
(10)	Y2S	Solenoid valve (Bypass)	Used to bypass the mixing unit during the normal operation.
(11)	Y3S	Four way valve (Heat exchanger)	Used to switch the operation mode between cooling and heating.
(12)	Y4S	Solenoid valve (Mixing unit inlet)	Use to adjust the amount of refrigeration oil and clean pipes during check operation. Use to prevent refrigerant from flowing into the mixing unit during normal operation.
(13)	Y5S	Solenoid valve (Circuit of oil return)	Used to adjust the amount of oil in the mixing unit.
(14)	Y6S	Solenoid valve (Close liquid pipe for stopped outdoor unit)	Used to prevent the accumulation of refrigerant in the non-operating outdoor units in a multi-outdoor-unit system.
(15)	Y7S	Solenoid valve (Receiver liquid level)	Used to detect the amount of refrigerant.
(16)	Y8S	Solenoid valve (Receiver gas vent)	Used to collect refrigerant to the receiver.
(17)	Y9S	Solenoid valve (Oil regulator outlet)	Used to adjust the refrigeration oil during the check operation.
(18)	Y10S	Solenoid valve (Refrigerant regulator gas vent pipe)	Used to collect refrigerant to the refrigerant regulator.
(19)	Y11S	Solenoid valve (Refrigerant regulator liquid pipe)	Used to collect refrigerant to the refrigerant regulator.
(20)	Y12S	Solenoid valve (Refrigerant regulator gas pipe)	Used to discharge refrigerant from the refrigerant regulator.
(21)	Y13S	Solenoid valve (Refrigerant regulator liquid outlet)	Used to discharge refrigerant from the refrigerant regulator.
(22)	S1NPH	High pressure sensor	Used to detect high pressure.
(23)	S2NPH	High pressure sensor (Liquid pipe outlet)	Used to detect pressure of liquid pipe.
(24)	S1NPL	Low pressure sensor	Used to detect low pressure.
(25)	S1PH	High pressure switch (For INV.)	In order to prevent the increase of high pressure when an error occurs, this switch is activated at high pressure of 4.0 MPa or more to stop the compressor operation.
(26)	S2PH	High pressure switch (For STD 1.)	
(27)	S3PH	High pressure switch (For STD 2.)	
(28)	S4PH	High pressure switch (for control)	In order to prevent the increase of field piping pressure when an error occurs, this switch is activated at pressure of 3.3 MPa or more to stop the compressor operation.
(29)	-	Subcooling heat exchanger	Apply subcooling to liquid refrigerant.
(30)	-	Pipe heat exchanger (A)	Heats the refrigerant that flows out of the receiver.
(31)	-	Pipe heat exchanger (B)	
(32)	-	Pipe heat exchanger (C)	
(33)	-	Fusible plug	The fusible part fuses at a temperature of 70 to 75°C, allow pressure to escape to the atmosphere. This is in order to prevent the pressure rise in case of a fire or other abnormal heating.
(34)	-		
(35)	-	Pressure regulating valve 1 (Receiver - Discharge pipe)	Open at 4.0 MPa or more to avoid pressure increase to prevent damage to functional parts by the pressure increase and to protect the field piping during transportation and storage.
(36)	-	Pressure regulating valve 2 (Liquid pipe - Receiver)	Open at 2 to 2.7 MPa or more to avoid pressure increase to prevent damage to functional parts by the pressure increase and to protect the field piping during transportation and storage.
(37)	R1T	Thermistor (Outdoor air)	Used to detect outdoor temperature, correct discharge pipe temperature and others.
(38)	R2T	Thermistor (Receiver liquid level)	Used to detect the refrigerant temperature at the liquid level detection point of the receiver.
(39)	R31T	Thermistor (M1C discharge pipe)	Used to detect discharge pipe temperature. Used for compressor temperature protection control.
(40)	R32T	Thermistor (M2C discharge pipe)	
(41)	R33T	Thermistor (M3C discharge pipe)	
(42)	R4T	Thermistor (Refrigerant regulator liquid pipe)	Detects the liquid pipe temperature of the refrigerant regulator. Used during adjustment of refrigerant amount.
(43)	R5T	Thermistor (Subcooling heat exchanger outlet)	Used to detect the gas pipe temperature on evaporation side of the subcooling heat exchanger, keep the superheated degree at the subcooling heat exchanger constant, and others.
(44)	R6T	Thermistor (Liquid pipe)	Used to detect liquid pipe temperature. Used for purpose such as drift prevention control between heating indoor and outdoor units in multi-outdoor unit systems.
(45)	R7T	Thermistor (Receiver gas vent outlet)	Used to detect the refrigerant temperature at the liquid level detection point of the receiver.
(46)	R8T	Thermistor (Suction pipe)	Used to detect suction pipe temperature. Used for purpose such as control for constant degree of suction superheat during heating.
(47)	R9T	Thermistor (Heat exchanger deicer)	Used to detect liquid pipe temperature of air heat exchanger. Used to make judgements on defrosting operation.

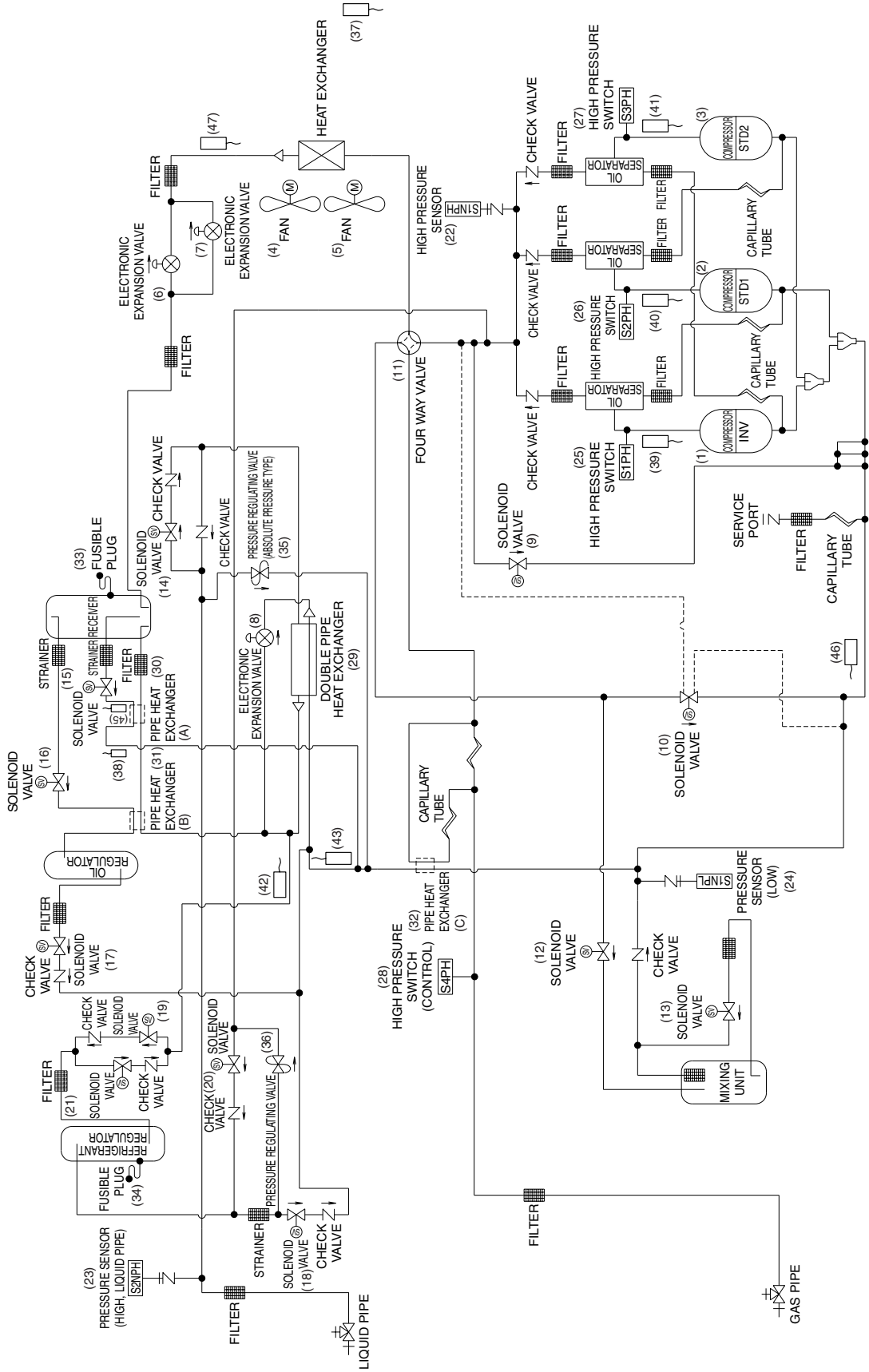

3D069110A

2. Functional Parts Layout

2.1 RQYQ8PY1B

Top View

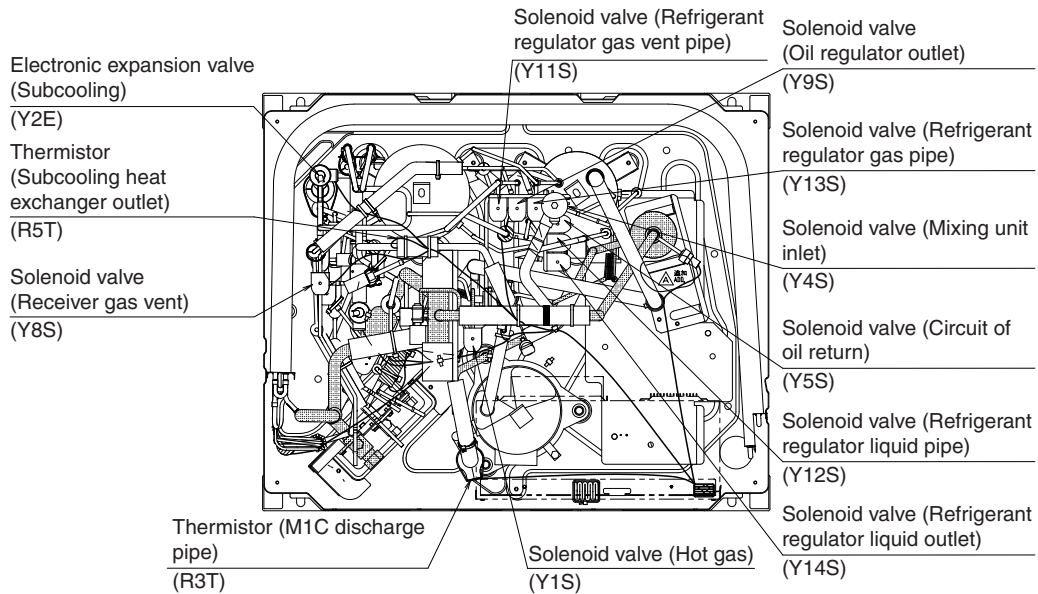

Front View

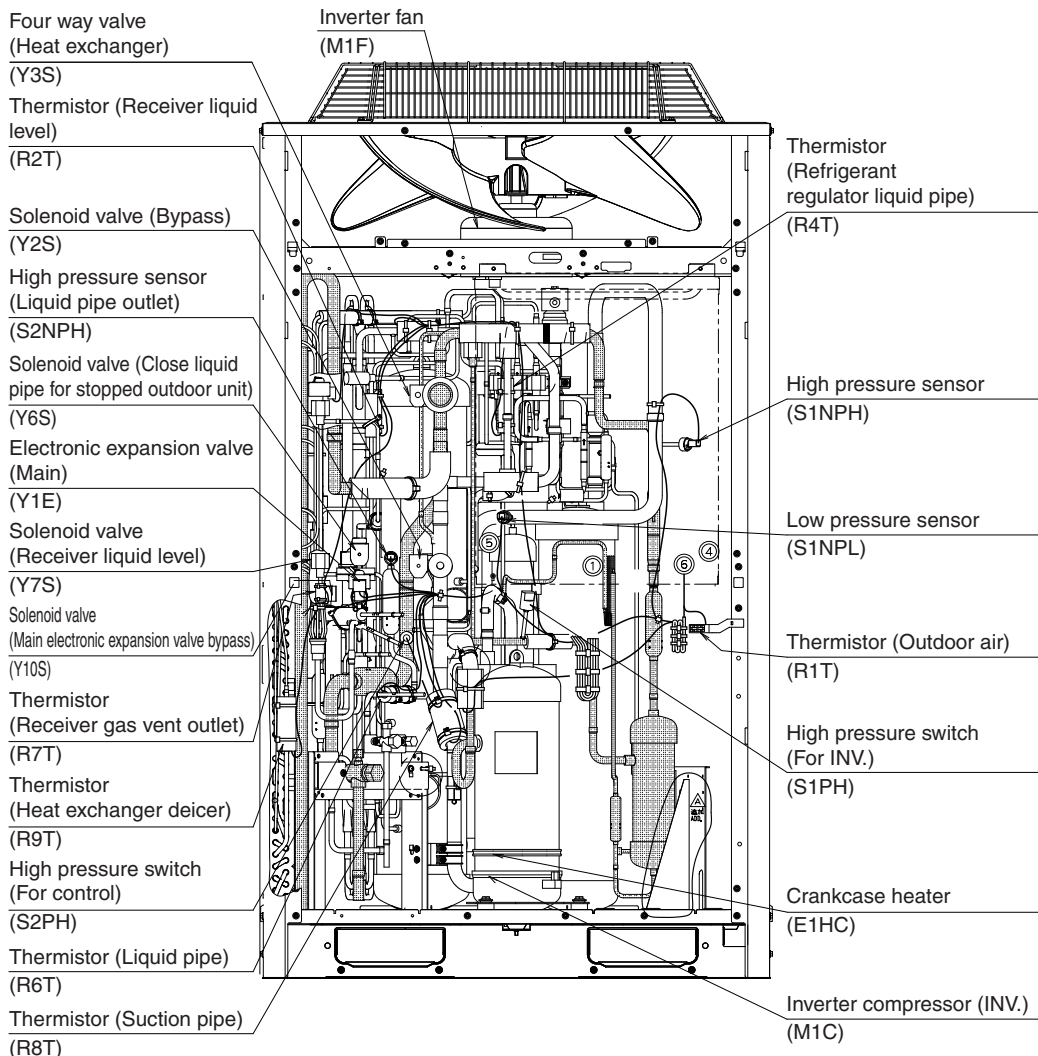

2.2 RQYQ10-12PY1B

Top View

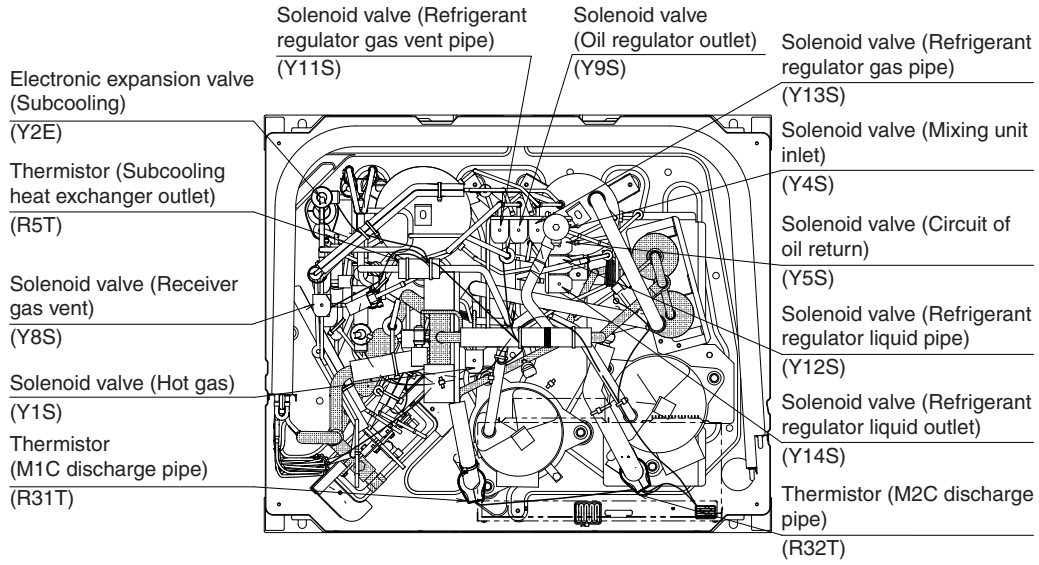

Front View

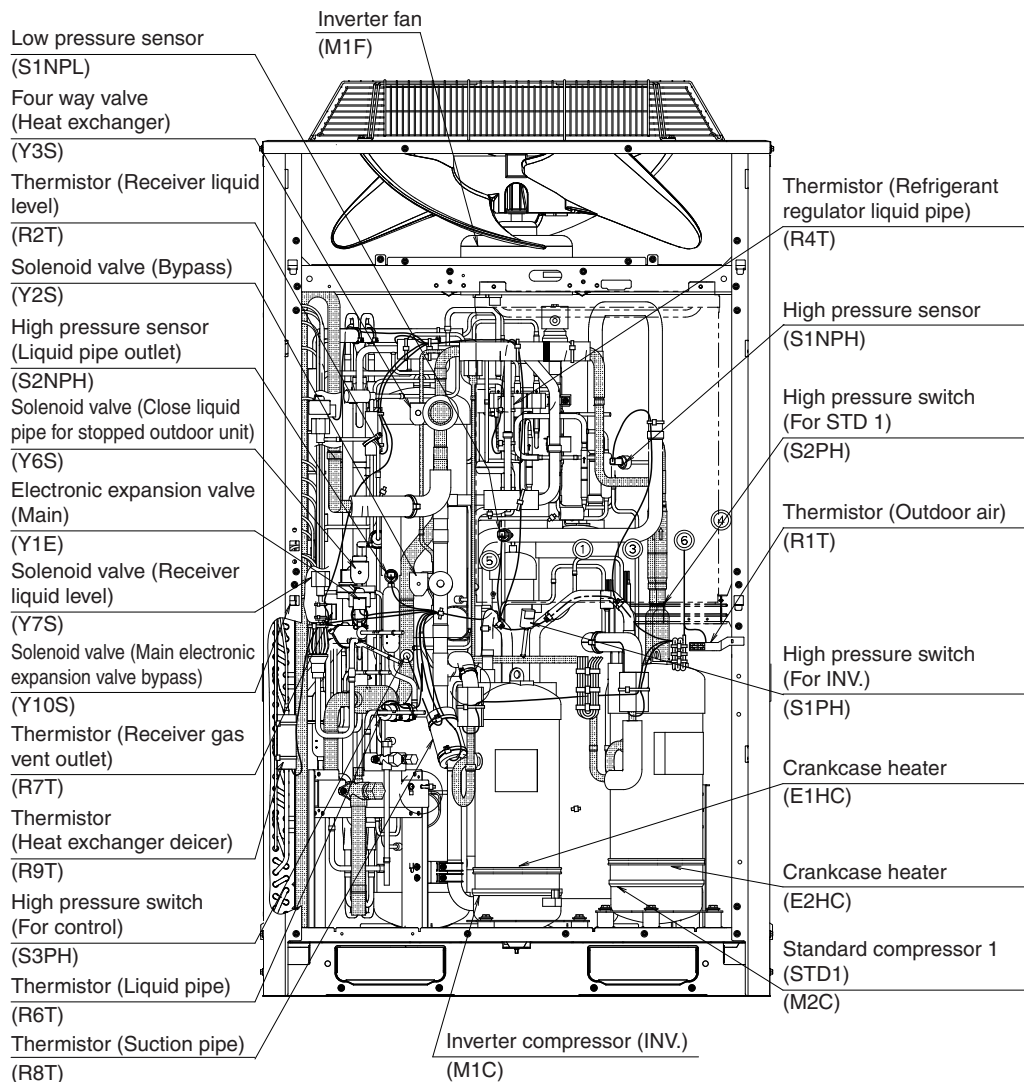

2.3 RQYQ14-16PY1B

Top View

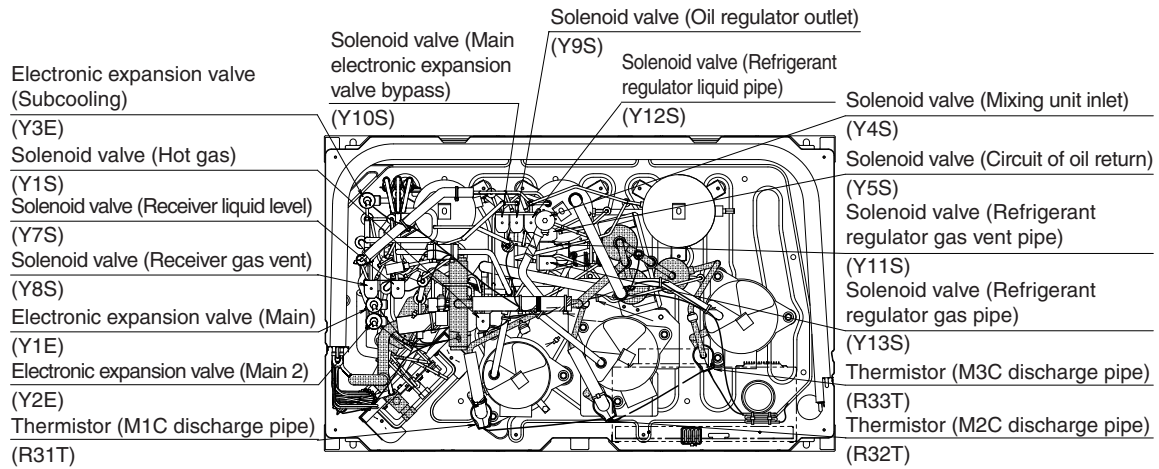

Front View

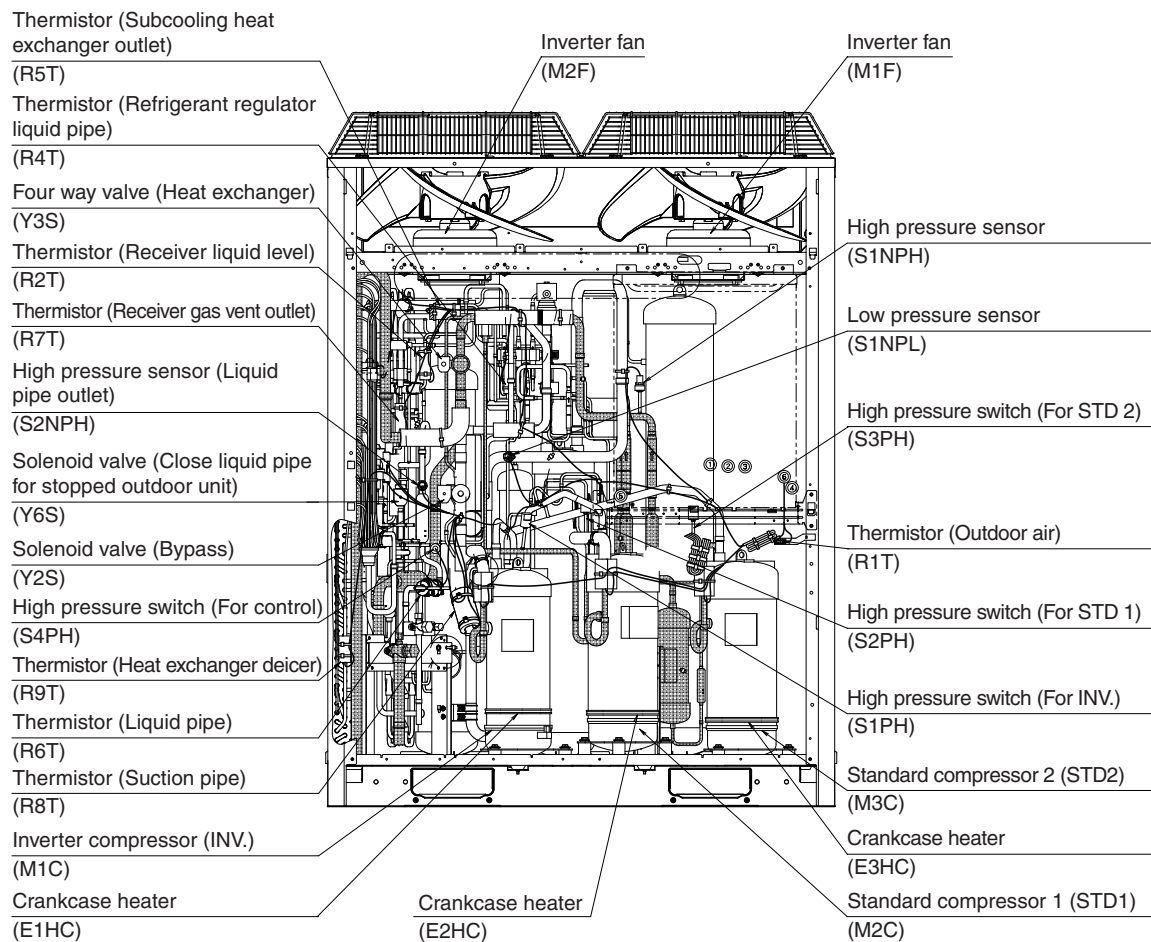

C: 1P273393A

3. Refrigerant Flow for Each Operation Mode

3.1 RQYQ8~16PY1B

Cooling operation

- "High temperature, high pressure gas"
- "High temperature, high pressure liquid"
- "Low temperature, low pressure"

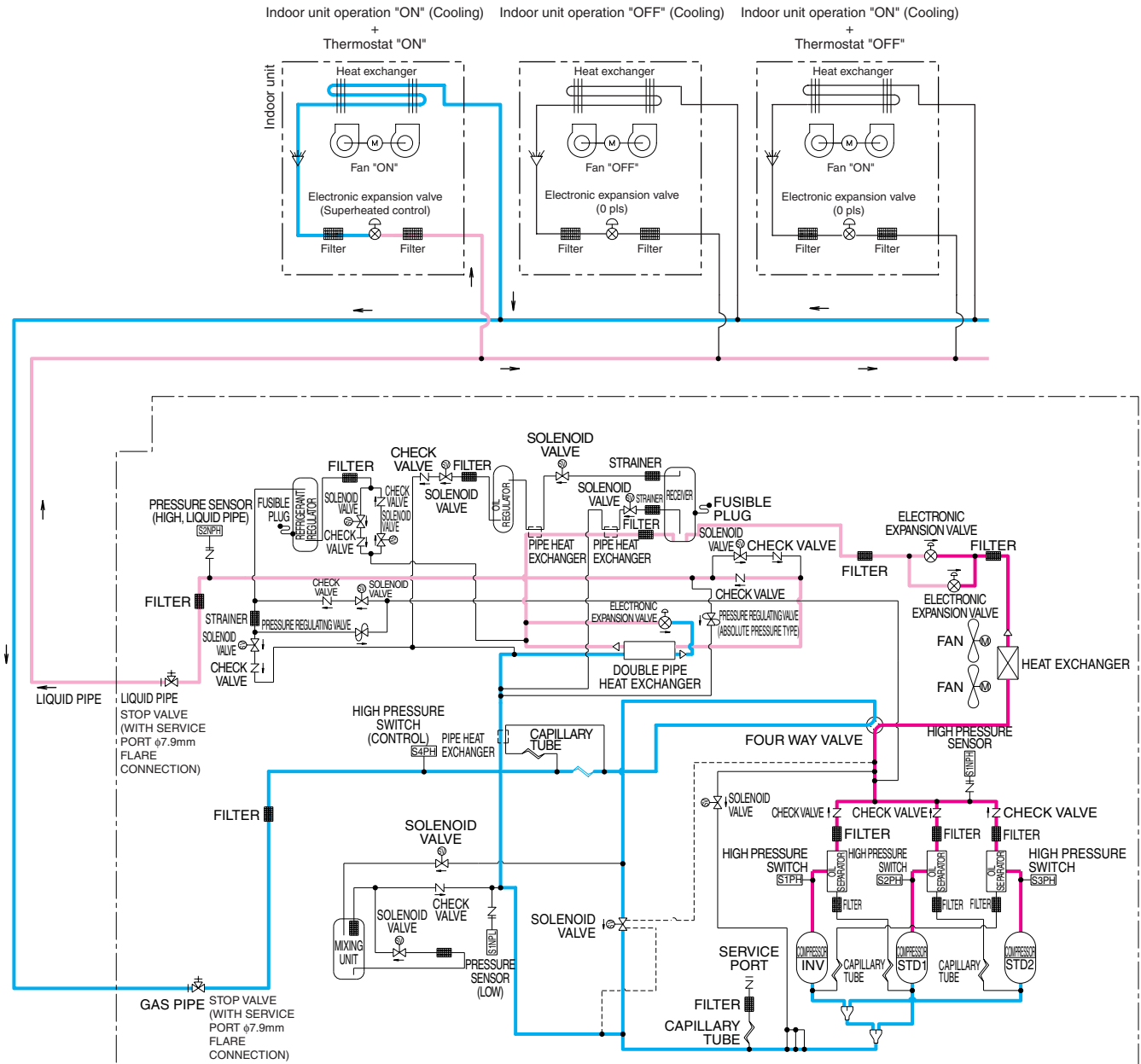

Cooling oil return / Heating oil return / Defrost operation

- "High temperature, high pressure gas"
- "High temperature, high pressure liquid"
- "Low temperature, low pressure"

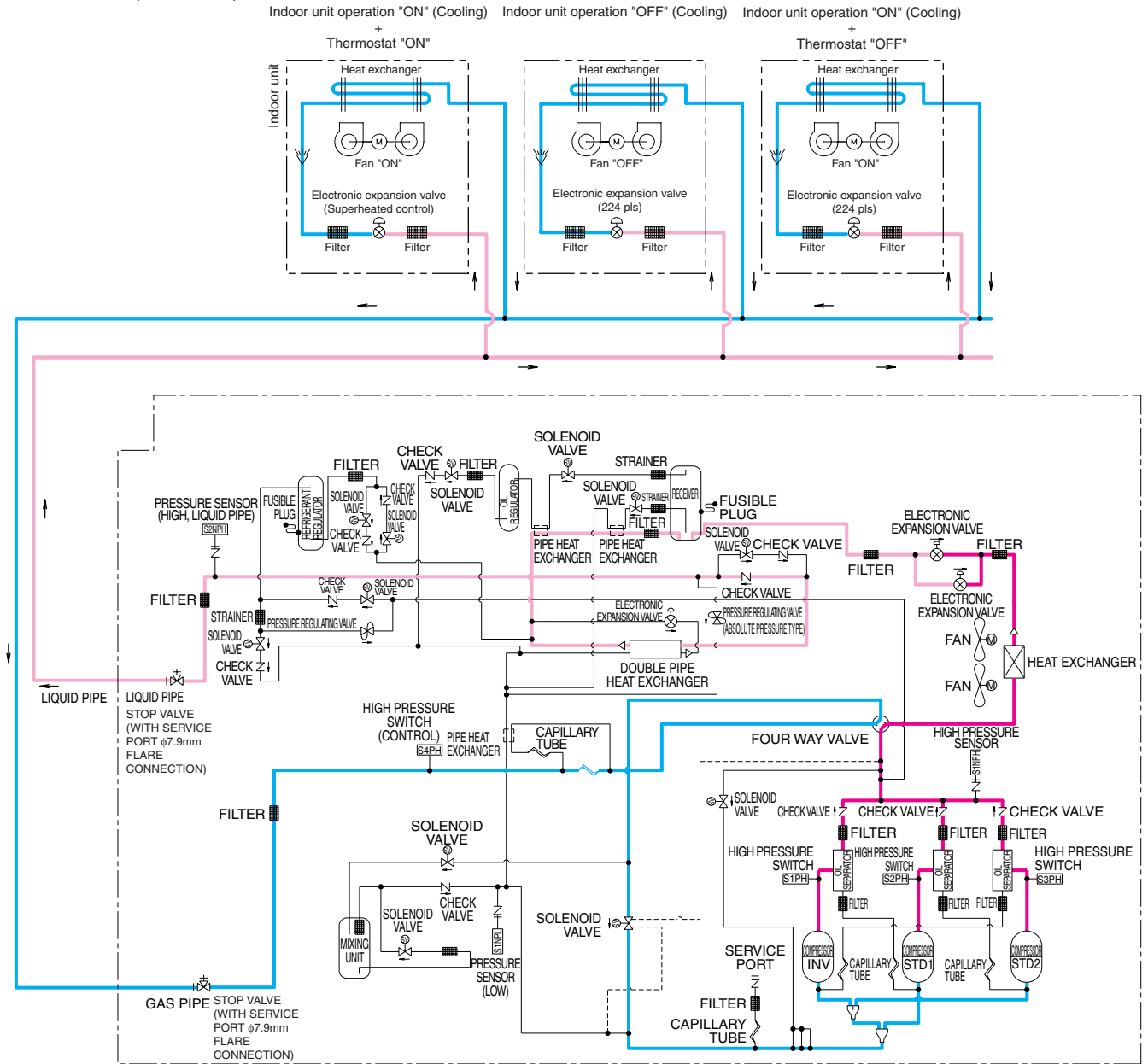

Heating operation

- "High temperature, high pressure gas"
- "High temperature, high pressure liquid"
- "Low temperature, low pressure"

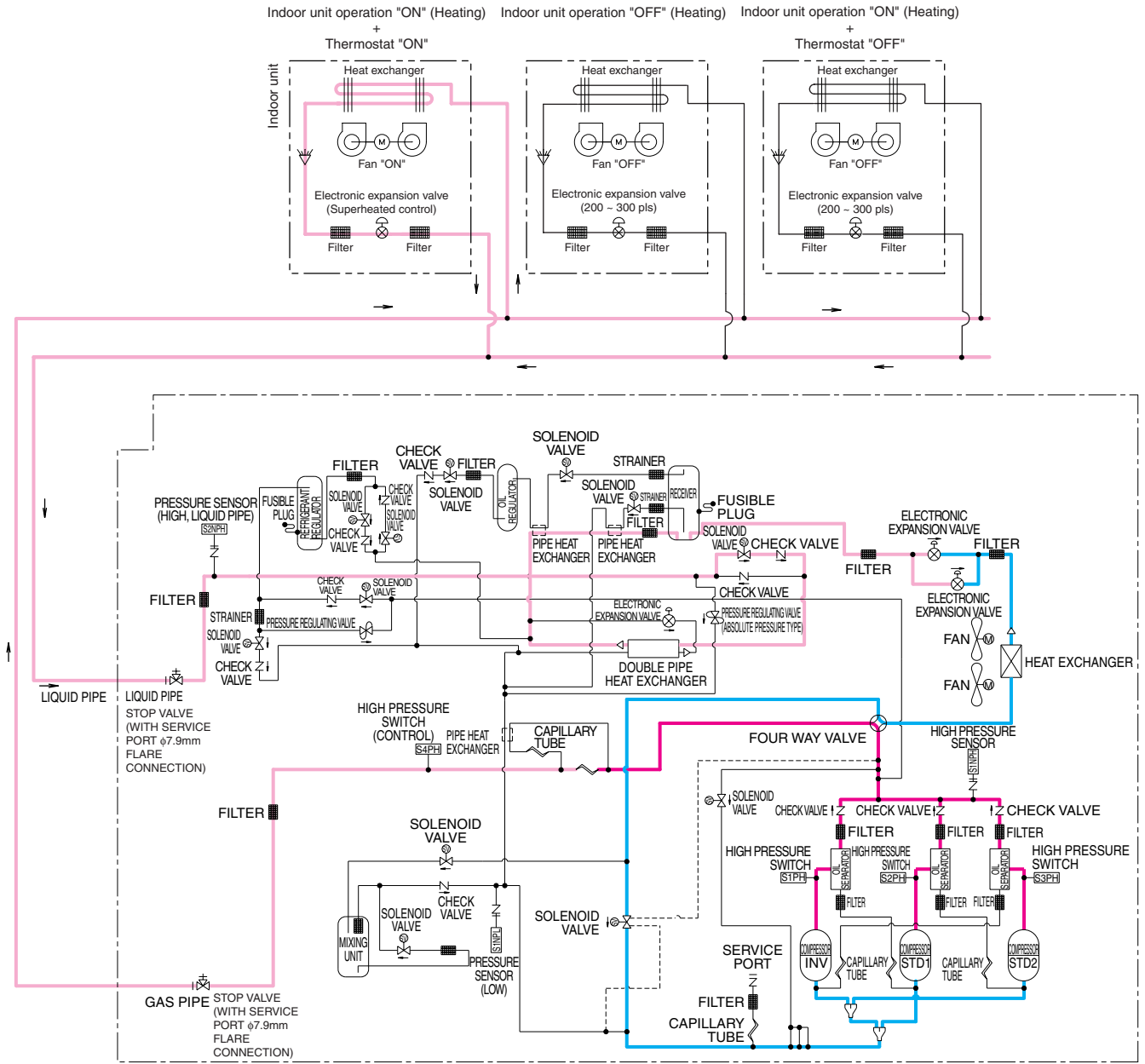

Part 4

Function

1. Function General.....	43
1.1 Operation Mode.....	43
2. Detailed Control Functions.....	44
2.1 Stop Operation	44
2.2 Standby	44
2.3 Startup Control	45
2.4 Normal Operation	46
2.5 Protection Control.....	51
2.6 Special Control.....	57

1. Function General

1.1 Operation Mode

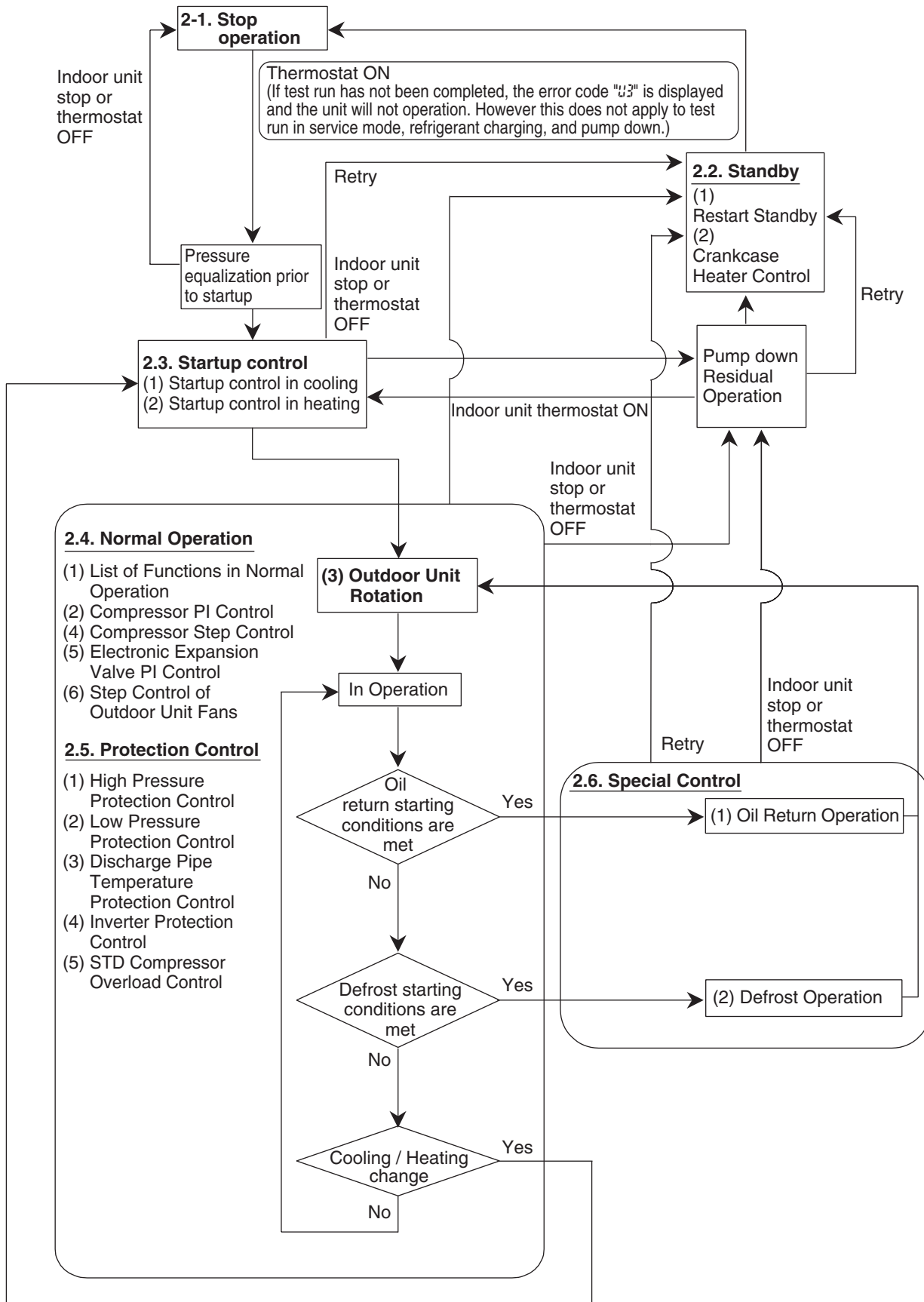

2. Detailed Control Functions

2.1 Stop Operation

2.1.1 Stop due to Error

In order to protect compressors, if any of the abnormal state occurs, the system will make "stop with thermostat OFF" and the error will be determined according to the number of retry times.

(Refer to "Error code and description" (P.100~) of the troubleshooting for the items to determine the error.)

2.1.2 When System is in Stop Mode

Both the master and slave units stop.

The four way valves both for heat exchanger switch and piping switch retain the condition before they were stopped.

2.2 Standby

2.2.1 Restart Standby

Used to forcedly stop the compressor for a period of 5 minutes, in order to prevent the frequent ON/OFF of the compressor and equalize the pressure within the refrigerant system.

In addition, the outdoor fan carry out the residual operation for a while to suppress the acceleration of the pressure equalizing and melting of the refrigerant to the evaporator.

2.2.2 Crankcase Heater Control

In order to prevent the refrigerant from melting in the compressor oil in the stopped mode, this mode is used to control the crankcase heater.

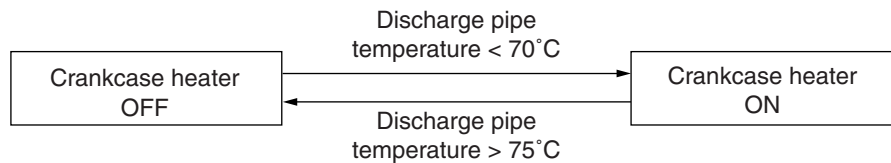

2.3 Startup Control

This control is used to equalize the pressure in the front and back of the compressor prior to the startup of the compressor, thus reducing startup loads. Furthermore, the inverter is turned ON to charge the capacitor. To avoid stresses to the compressor due to oil return or else after the startup, the following control is made and the position of the four way valve is also determined. Start both the master and the slave units simultaneously to position the four way valve.

(1) Startup Control in Cooling Operation

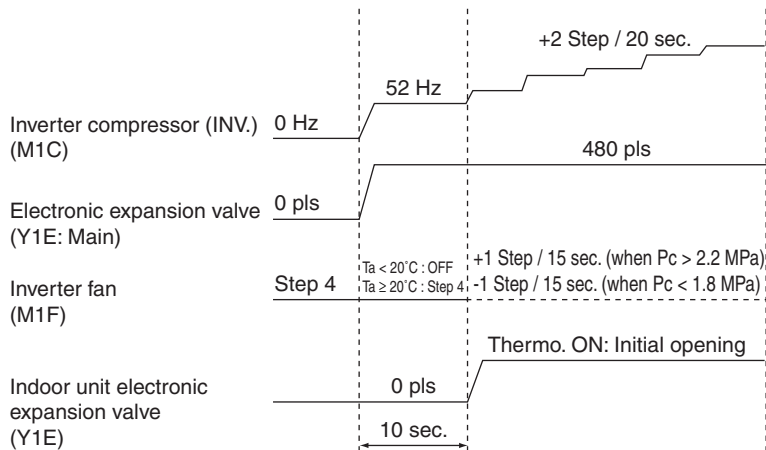

[Ending conditions]

- OR
- A lapse of 130 sec.
 - $T_c > 48^\circ\text{C}$
 - $P_e < 0.54\text{Pa}$
 - $P_c - P_e > 0.4\text{MPa}$.

Ta: Outdoor air temperature
 Tc: High pressure equivalent saturation temperature
 Pc: Value detected by high pressure sensor
 Pe: Value detected by low pressure sensor

(2) Startup Control in Heating Operation

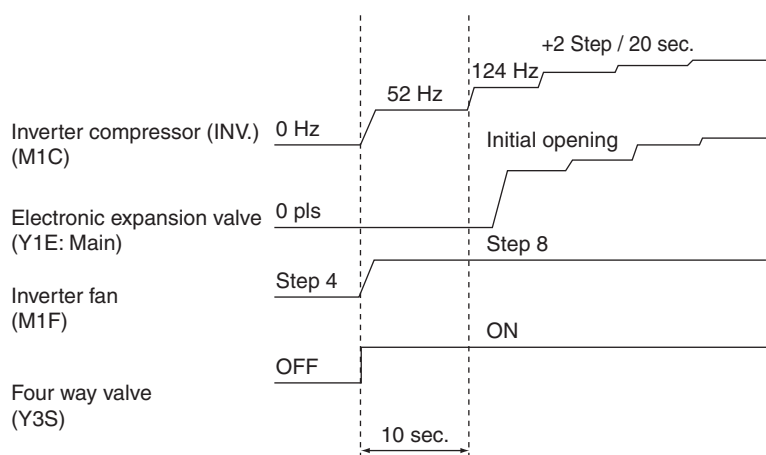

[Ending conditions]

- OR
- A lapse of 130 sec.
 - $P_c > 2.65\text{MPa}$
 - $P_c - P_e > 0.4\text{MPa}$.

2.4 Normal Operation

2.4.1 List of Functions in Normal Operation

Part Name	Electric Symbol			Normal Cooling	Normal Heating
	RQYQ8P	PQYQ10-12P	PQYQ14-16P		
Compressor	M1C	M1C	M1C	PI Control	PI Control
	–	M2C	M2C		
	–	–	M3C		
Outdoor unit fan	M1F	M1F	M1F, M2F	Depends on the mode of the cooling heat exchanger	Depends on the mode of the cooling heat exchanger
Four way valve	Y3S	Y3S	Y3S	OFF	ON
Electronic expansion valve (Main)	Y1E	Y1E	Y1E	2000 pls	Depends on the control of the electronic expansion valve
Electronic expansion valve (Main 2)	–	–	Y2E		
Electronic expansion valve (Subcooling)	Y2E	Y2E	Y3E	Depends on the control of the electronic expansion valve	0 pls
Solenoid valve (Hot gas)	Y1S	Y1S	Y1S	OFF	OFF
Solenoid valve (Receiver gas vent)	Y8S	Y8S	Y8S	OFF	OFF
Solenoid valve (Circuit of oil return)	Y5S	Y5S	Y5S	ON	ON
Solenoid valve (Close liquid pipe for stopped outdoor unit)	Y6S	Y6S	Y6S	OFF	ON
Solenoid valve (Main electronic expansion valve bypass)	Y10S	Y10S	–	ON	OFF
Solenoid valve (Refrigerant regulator gas vent pipe)	Y11S	Y11S	Y10S	OFF	OFF
Solenoid valve (Refrigerant regulator liquid pipe)	Y12S	Y12S	Y11S	OFF	OFF
Solenoid valve (Refrigerant regulator gas pipe)	Y13S	Y13S	Y12S	OFF	OFF
Solenoid valve (Refrigerant regulator liquid outlet)	Y14S	Y14S	Y13S	OFF	OFF
Solenoid valve (Receiver liquid level)	Y7S	Y7S	Y7S	OFF	OFF
Solenoid valve (Mixing unit inlet)	Y4S	Y4S	Y4S	OFF	OFF
Solenoid valve (Bypass)	Y2S	Y2S	Y2S	OFF	OFF
Solenoid valve (Oil regulator outlet)	Y9S	Y9S	Y9S	ON	ON
Indoor unit fan	M1F	M1F	M1F	Depends on the indoor unit	Depends on the indoor unit
Indoor unit electronic expansion valve	Y1E	Y1E	Y1E	Depends on the indoor unit	Depends on the indoor unit

2.4.2 Compressor PI Control

Carries out the compressor capacity PI control to maintain Te at constant during cooling operation and Tc at constant during heating operation to ensure stable unit performance.

[Cooling operation]

Controls compressor capacity to adjust Te to achieve target value (TeS).

Te set value (Make this setting while in Setting mode 2.)

Te setting

L	M (Normal) (factory setting)	H				
3°C	6°C	7°C	8°C	9°C	10°C	11°C

Te : Low pressure equivalent saturation temperature (°C)

TeS : Target temperature of Te (Varies depending on Te setting, operating frequency, etc.)

* On multi-outdoor-unit systems, this control is made according to values of the first-priority unit, which is detected with the pressure sensor.

[Heating operation]

Controls compressor capacity to adjust Tc to achieve target value (TcS).

Tc set value (Make this setting while in Setting mode 2.)

Tc setting

L	M (Normal) (factory setting)	H
43°C	46°C	47°C

Tc : High pressure equivalent saturation temperature (°C)

TcS : Target temperature of Tc (Varies depending on Tc setting, operating frequency, etc.)

* On multi-outdoor-unit systems, this control is made according to values of the first-priority unit, which is detected with the pressure sensor.

2.4.3 Outdoor Unit Rotation

In the case of multi-outdoor-unit system, this outdoor unit rotation is used to prevent the compressor from burning out due to unbalanced oil level between outdoor units.

[Details of outdoor unit rotation]

In case of multi-outdoor-unit system, each outdoor unit is given an operating priority for the control.

Outdoor unit rotation makes it possible to change the operating priority of outdoor units.

Thus, the system becomes free of compressors that stop over an extended period of time at the time of partial loading, preventing unbalanced oil level.

[Timing of outdoor unit rotation]

- OR
- At the beginning of the starting control
 - After oil return operation
 - After defrost operation
 - When any of outdoor unit stops for a period of 20 minutes or more (in heating)

Example) The following diagram shows outdoor unit rotation in combination of 3 outdoor units. (in heating)

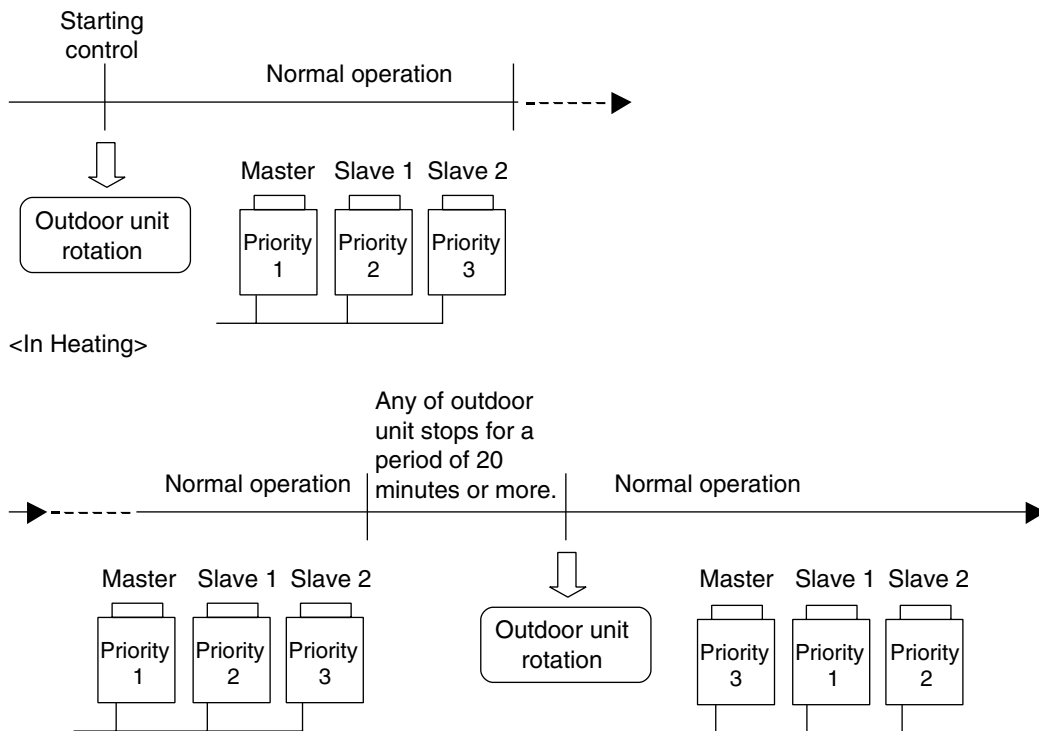

* "Master unit", "slave unit 1" and "slave unit 2" in this section are the names for installation. They are determined in installation work, and not changed thereafter. (These names are different from "master unit" and "slave unit" for control.)

The outdoor unit connected the control wires (F1 and F2) for the indoor unit should be designated as main unit.

Consequently, the LED display on the main PCB for "master unit", "slave unit 1" and "slave unit 2" do not change.

<System with two outdoor units>

	Outdoor Unit 1	Outdoor Unit 2
Previous time	Priority 1	Priority 2
This time	Priority 2	Priority 1
Next time	Priority 1	Priority 2

<System with three outdoor units>

	Outdoor Unit 1	Outdoor Unit 2	Outdoor Unit 3
Previous time	Priority 1	Priority 2	Priority 3
This time	Priority 3	Priority 1	Priority 2
Next time	Priority 2	Priority 3	Priority 1
One time after the next	Priority 1	Priority 2	Priority 3

2.4.4 Compressor Step Control

Compressor operations vary with the following steps according to information in “2.4.2 Compressor PI Control”.

RQYQ8PY1B

STEP No.	INV.
1	52Hz
2	57Hz
3	62Hz
4	68Hz
5	74Hz
6	81Hz
7	88Hz
8	96Hz
9	104Hz
10	110Hz
11	116Hz
12	124Hz
13	133Hz
14	143Hz
15	158Hz
16	165Hz
17	177Hz
18	189Hz
19	202Hz
20	210Hz
21	218Hz
22	232Hz
23	248Hz
24	266Hz

RQYQ10 ·12PY1B

STEP No.	INV.	STD1
1	52Hz	OFF
2	57Hz	OFF
3	62Hz	OFF
4	68Hz	OFF
5	74Hz	OFF
6	81Hz	OFF
7	88Hz	OFF
8	96Hz	OFF
9	104Hz	OFF
10	110Hz	OFF
11	116Hz	OFF
12	124Hz	OFF
13	133Hz	OFF
14	143Hz	OFF
15	158Hz	OFF
16	165Hz	OFF
17	177Hz	OFF
18	189Hz	OFF
19	202Hz	OFF
20	210Hz	OFF
21	52Hz	ON
22	62Hz	ON
23	68Hz	ON
24	74Hz	ON
25	81Hz	ON
26	88Hz	ON
27	96Hz	ON
28	104Hz	ON
29	116Hz	ON
30	124Hz	ON
31	133Hz	ON
32	143Hz	ON
33	158Hz	ON
34	177Hz	ON
35	189Hz	ON
36	202Hz	ON
37	210Hz	ON

RQYQ14 ·16PY1B

STEP No.	INV.	STD1	STD2
1	52Hz	OFF	OFF
2	57Hz	OFF	OFF
3	62Hz	OFF	OFF
4	68Hz	OFF	OFF
5	74Hz	OFF	OFF
6	81Hz	OFF	OFF
7	88Hz	OFF	OFF
8	96Hz	OFF	OFF
9	104Hz	OFF	OFF
10	110Hz	OFF	OFF
11	116Hz	OFF	OFF
12	124Hz	OFF	OFF
13	133Hz	OFF	OFF
14	143Hz	OFF	OFF
15	158Hz	OFF	OFF
16	165Hz	OFF	OFF
17	177Hz	OFF	OFF
18	189Hz	OFF	OFF
19	202Hz	OFF	OFF
20	210Hz	OFF	OFF
21	52Hz	ON	OFF
22	62Hz	ON	OFF
23	68Hz	ON	OFF
24	74Hz	ON	OFF
25	81Hz	ON	OFF
26	88Hz	ON	OFF
27	96Hz	ON	OFF
28	104Hz	ON	OFF
29	116Hz	ON	OFF
30	124Hz	ON	OFF
31	133Hz	ON	OFF
32	143Hz	ON	OFF
33	158Hz	ON	OFF
34	177Hz	ON	OFF
35	189Hz	ON	OFF
36	202Hz	ON	OFF
37	210Hz	ON	OFF
38	52Hz	ON	ON
39	62Hz	ON	ON
40	74Hz	ON	ON
41	88Hz	ON	ON
42	96Hz	ON	ON
43	110Hz	ON	ON
44	124Hz	ON	ON
45	143Hz	ON	ON
46	158Hz	ON	ON
47	165Hz	ON	ON
48	177Hz	ON	ON
49	189Hz	ON	ON
50	202Hz	ON	ON
51	210Hz	ON	ON

2.4.5 Electronic Expansion Valve PI Control

Main electronic expansion valve control

When the outdoor unit heat exchanger is performed via the evaporator, this function is used to exert PI control on the electronic expansion valve (Y1E) so that the evaporator outlet superheated degree (SH) will become constant.

$$SH = T_g - T_e$$

SH: Evaporator outlet superheated degree (°C)

T_g : Suction pipe temperature (°C) detected by the thermistor R8T.

T_e : Low pressure equivalent saturation temperature (°C)

Subcooling electronic expansion valve control

In order to make the maximum use of the subcooling heat exchanger, this function is used to exert PI control on the electronic expansion valve (Y2E or Y3E) so that the evaporator-side gas pipe superheated degree (SH) will become constant.

$$SH = T_{sh} - T_e$$

SH: Evaporator outlet superheated degree (°C)

T_{sh}: Suction pipe temperature (°C) detected by the subcooling heat exchanger outlet thermistor R5T.

T_e: Low pressure equivalent saturation temperature (°C)

2.4.6 Step Control of Outdoor Unit Fans

Used to control the revolutions of outdoor unit fans in the steps listed in table below, according to condition changes.

STEP No.	Fan revolutions (rpm)						
	RQYQ8PY1B	RQYQ10PY1B	RQYQ12PY1B	RQYQ14PY1B		RQYQ16PY1B	
				MF1	MF2	MF1	MF2
0	0	0	0	0	0	0	0
1	350	350	350	230	0	230	230
2	370	370	370	380	0	380	380
3	400	400	400	290	260	290	290
4	450	460	460	375	345	375	375
5	540	560	560	570	540	570	570
6	610	710	710	720	690	720	720
7	760	Cooling: 821 Heating: 800	870	1091	1061	1091	980
8	Cooling: 796 Heating: 780	Cooling: 821 Heating: 800	870	1136	1106	1136	980

* Figures listed above are all those controlled while in standard mode, which vary when the system is set to high static pressure or capacity precedence mode.

[Control at a low outdoor temperature during cooling]

Secure the liquid pressure and circulating rate in the indoor unit through high pressure control with the outdoor fan when the outdoor temperature is low during cooling. Control the fan with the target T_c (high pressure equivalent saturation temperature) = 34°C

2.5 Protection Control

2.5.1 High Pressure Protection Control

This high pressure protection control is used to prevent the activation of protection devices due to abnormal increase of high pressure and to protect compressors against the transient increase of high pressure.

[In cooling]

In case of multi-outdoor-unit system, each outdoor unit performs this control individually in the following sequence.

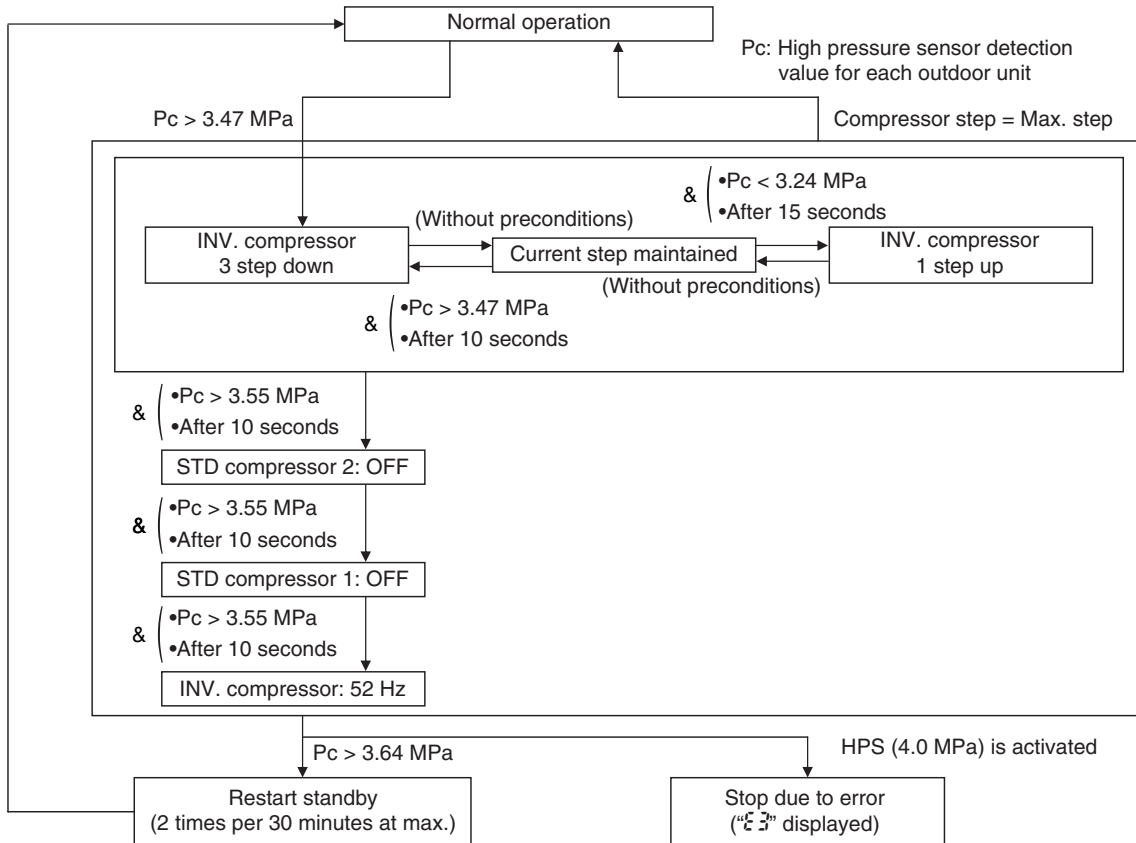

[In heating]

In case of multi-outdoor-unit system, the following control is performed in the entire system.

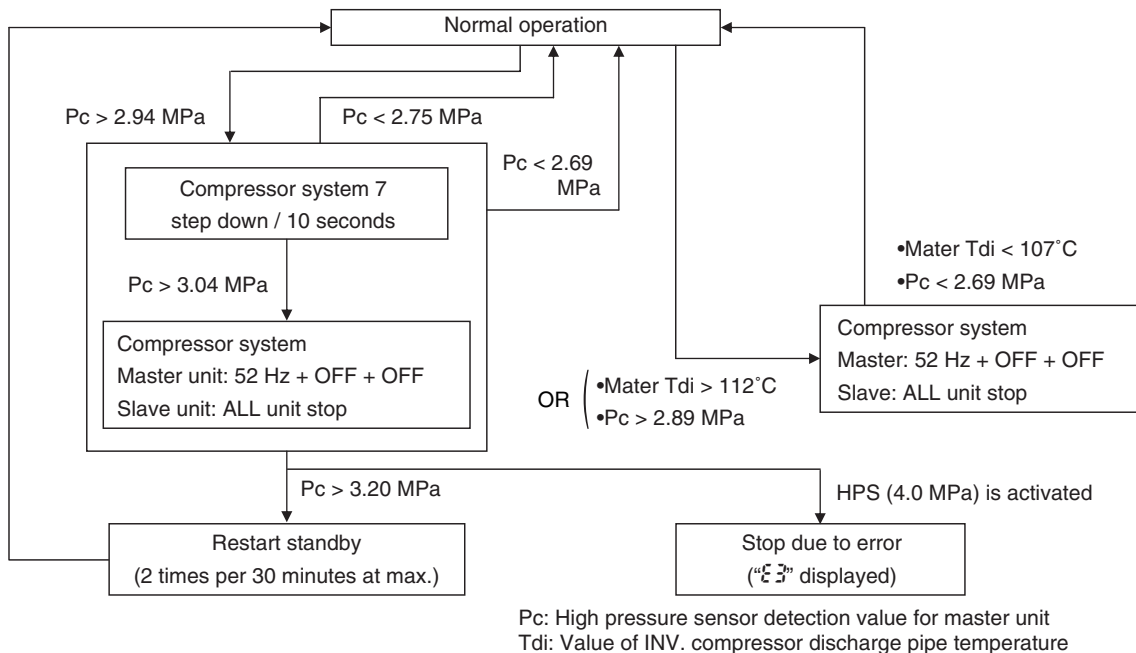

2.5.2 Low Pressure Protection Control

This low pressure protection control is used to protect compressors against the transient decrease of low pressure.

[In cooling]

In case of multi-outdoor-unit system, the following control is performed in the entire system.

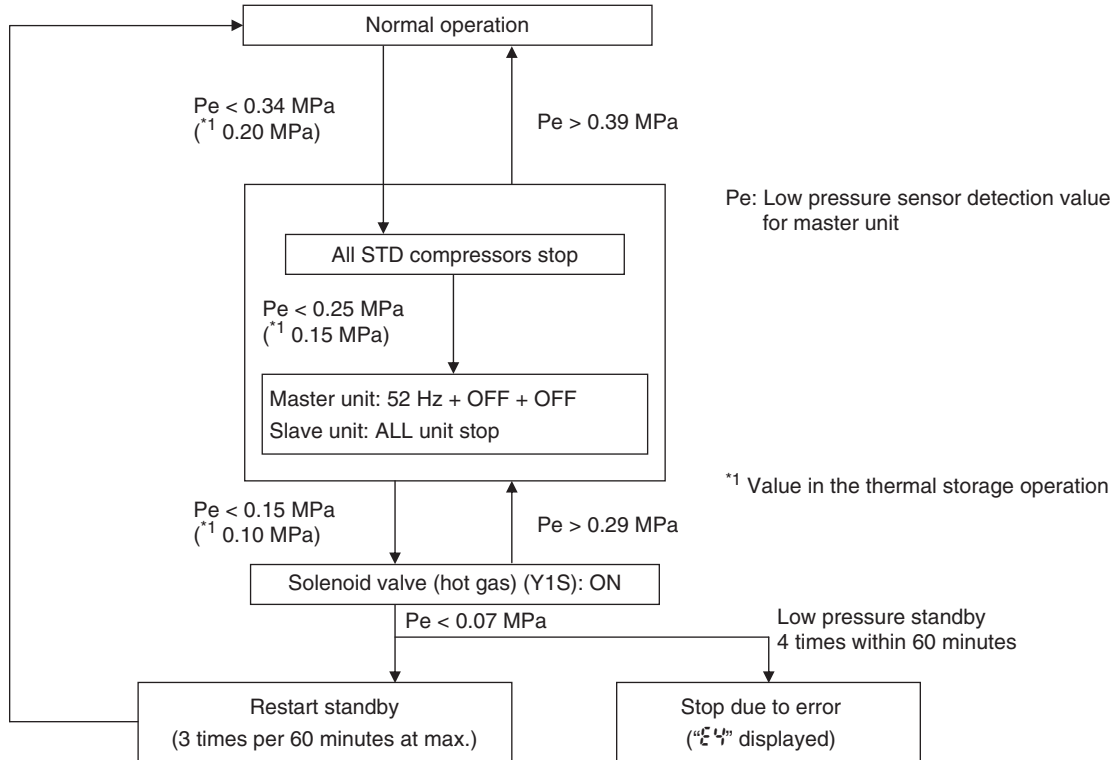

[In heating]

In case of multi-outdoor-unit system, each outdoor unit performs this control individually in the following sequence.

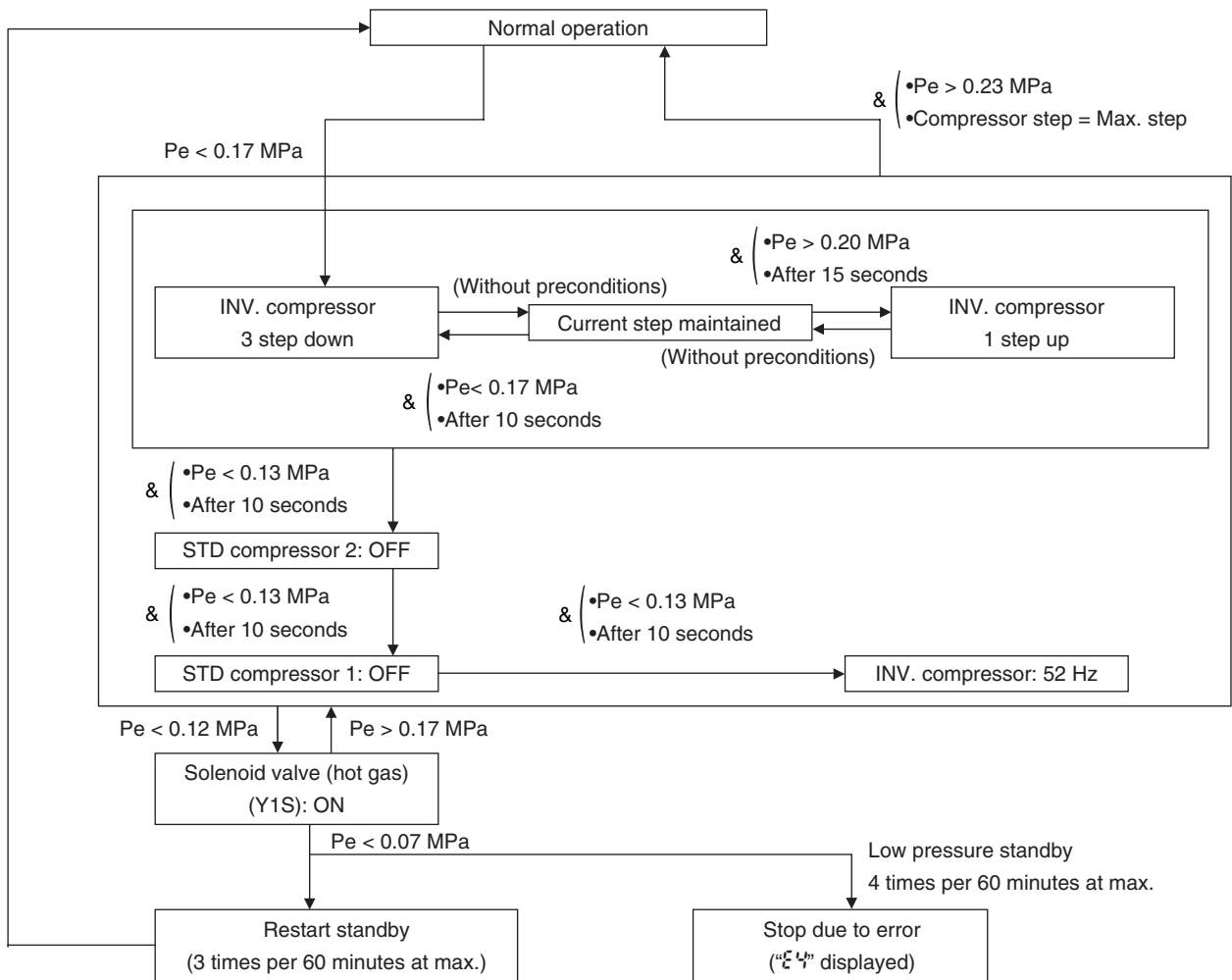

2.5.3 Discharge Pipe Protection Control

This discharge pipe protection control is used to protect the compressor internal temperature against an error or transient increase of discharge pipe temperature.

In case of multi-outdoor-unit system, each outdoor unit performs this control individually in the following sequence.

[INV. compressor]

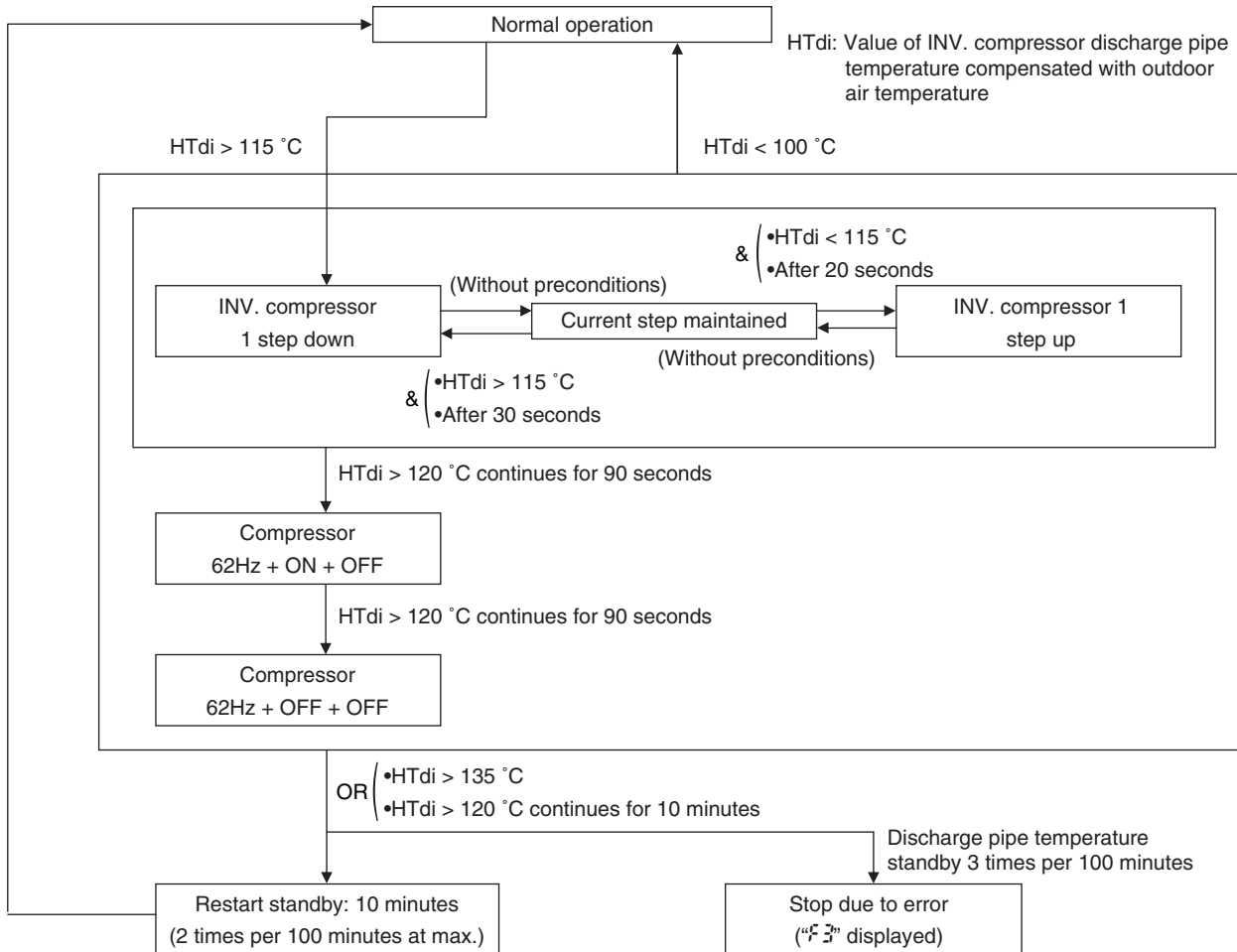

[STD. compressor]

In case of multi-outdoor-unit system, each outdoor unit performs this control individually in the following sequence.

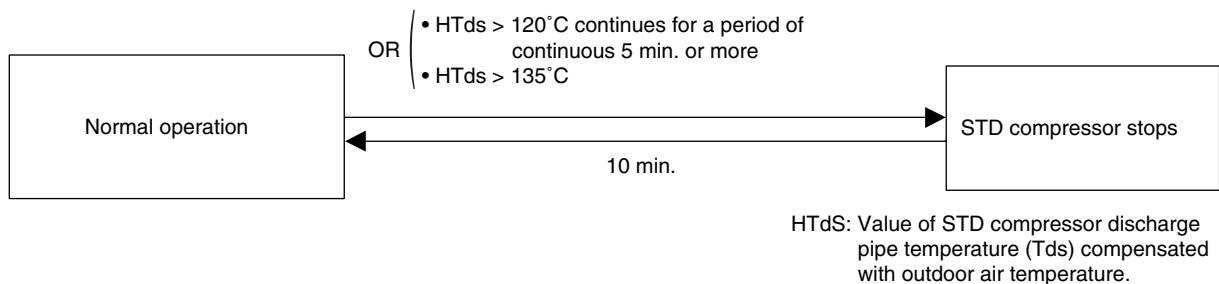

2.5.4 Inverter Protection Control

Inverter current protection control and inverter fin temperature control are performed to prevent tripping due to an error, or transient inverter overcurrent, and fin temperature increase.

[Inverter overcurrent protection control]

In the case of multi-outdoor-unit system, each INV. compressor performs these controls in the following sequence.

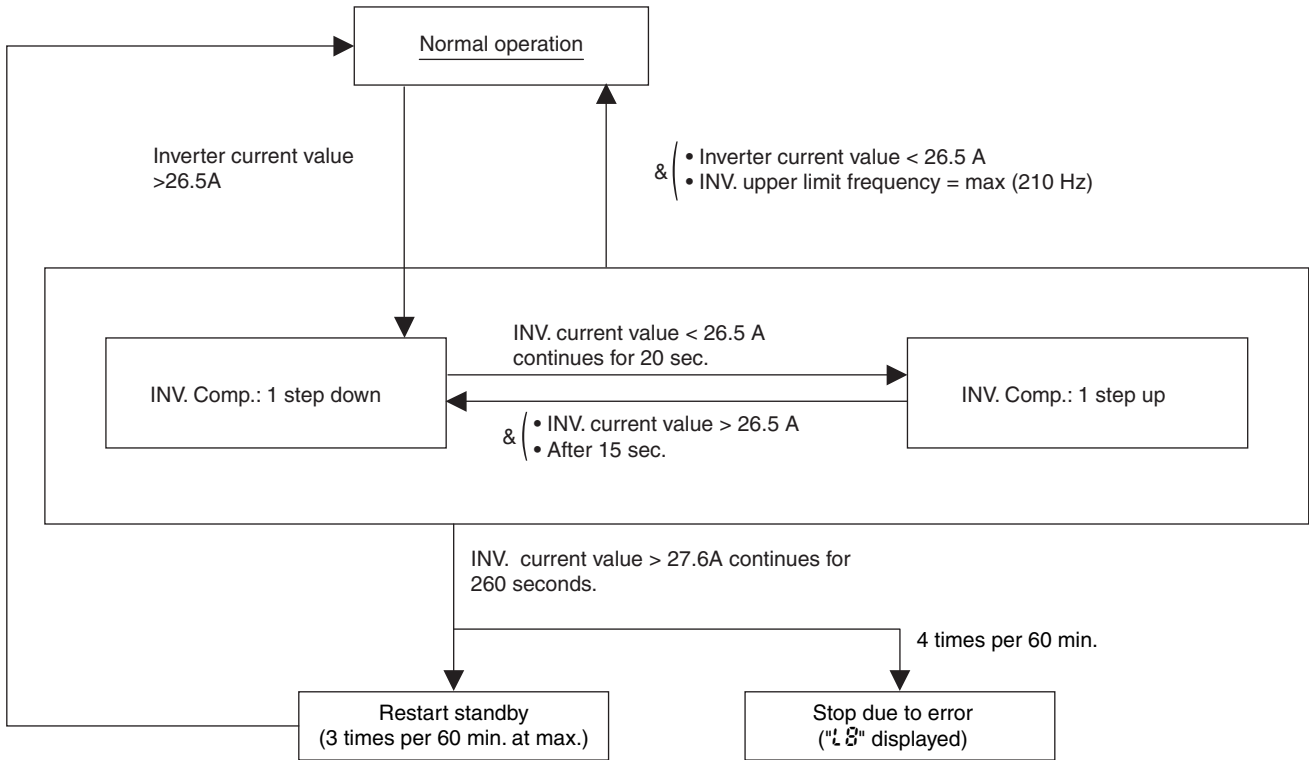

[Inverter fin temperature control]

In the case of multi-outdoor-unit system, each INV. compressor performs these controls in the following sequence.

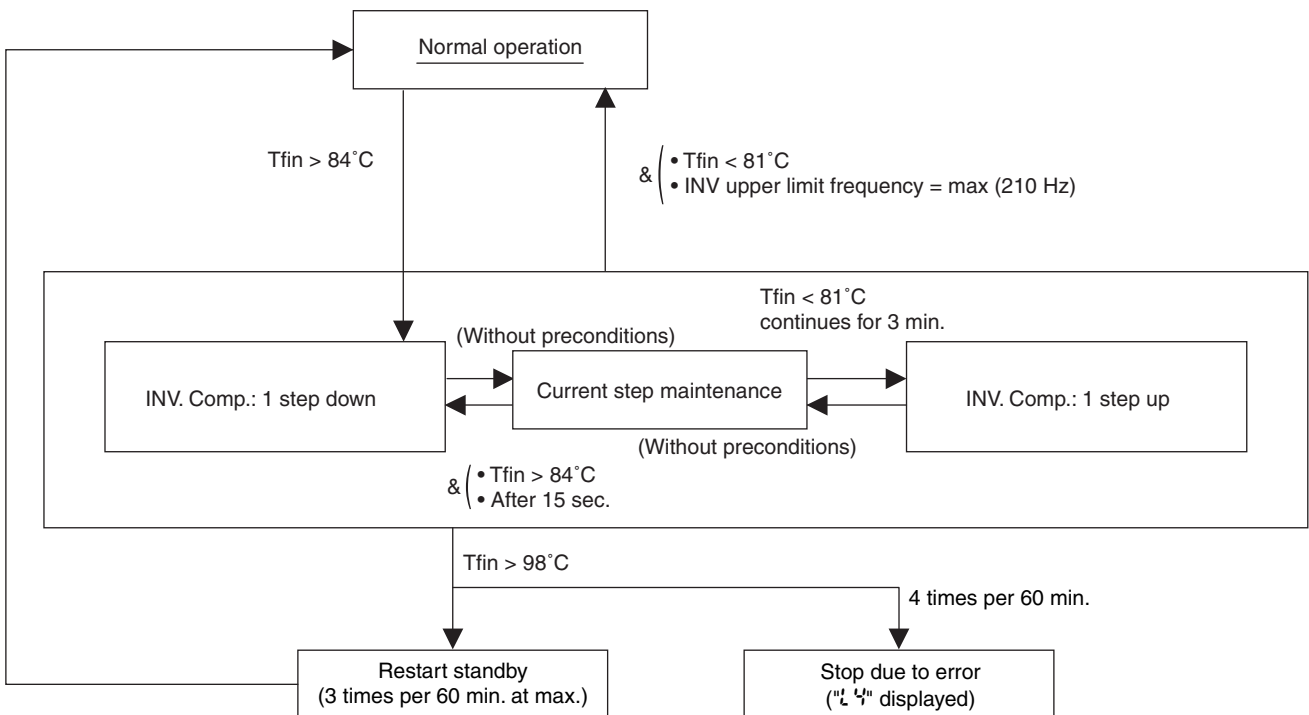

2.5.5 STD Compressor Overload Protection

This control is used to prevent abnormal heating due to overcurrent to the compressor resulting from failures of STD compressor such as locking.

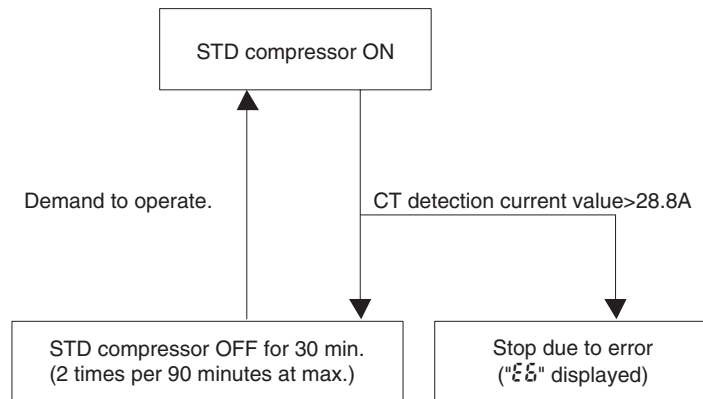

2.6 Special Control

2.6.1 Oil Return Operation

In order to prevent the compressor from running out of oil, the oil return operation is conducted to recover oil flown out from the compressor to the system side.

(1) Oil Return Operation in Cooling

[Start conditions]

Referring to the set conditions for the following items, start the oil return operation in cooling.

- 2 hours after initial power ON
- A lapse of every 1 ~ 2 hours during low-load operation
- A lapse of every 8 hours during high-load operation

Part Name	Electric Symbol			Oil return operation
	RQYQ8P	PQYQ10-12P	PQYQ14-16P	
Compressor	M1C	M1C	M1C	177Hz
	–	M2C	M2C	No instruction → OFF
	–	–	M3C	No instruction → OFF
Outdoor unit fan	M1F	M1F	M1F, M2F	Fan control in normal cooling (Heat exchanging mode)
Four way valve	Y3S	Y3S	Y3S	OFF
Electronic expansion valve (Main)	Y1E	Y1E	Y1E	480 pls
Electronic expansion valve (Main 2)	–	–	Y2E	
Electronic expansion valve (Subcooling)	Y2E	Y2E	Y3E	0 pls
Solenoid valve (Hot gas)	Y1S	Y1S	Y1S	ON
Solenoid valve (Receiver gas vent)	Y8S	Y8S	Y8S	OFF
Solenoid valve (Circuit of oil return)	Y5S	Y5S	Y5S	OFF
Solenoid valve (Close liquid pipe for stopped outdoor unit)	Y6S	Y6S	Y6S	ON
Solenoid valve (Main electronic expansion valve bypass)	Y10S	Y10S	–	ON
Solenoid valve (Refrigerant regulator gas vent pipe)	Y11S	Y11S	Y10S	OFF
Solenoid valve (Refrigerant regulator liquid pipe)	Y12S	Y12S	Y11S	OFF
Solenoid valve (Refrigerant regulator gas pipe)	Y13S	Y13S	Y12S	OFF
Solenoid valve (Refrigerant regulator liquid outlet)	Y14S	Y14S	Y13S	OFF
Solenoid valve (Receiver liquid level)	Y7S	Y7S	Y7S	OFF
Solenoid valve (Mixing unit inlet)	Y4S	Y4S	Y4S	OFF
Solenoid valve (Bypass)	Y2S	Y2S	Y2S	OFF
Solenoid valve (Oil regulator outlet)	Y9S	Y9S	Y9S	ON

* In the case of multi-outdoor-unit system,

Master unit: Performs the operations listed in the table above.

Slave units: Operating units perform the operations listed in the table above.

Non-operating units perform the operations listed in the table above from the oil return operation.
(Non-operating unit stops during “oil return preparation operation”.)

Indoor unit actuator		Cooling oil return operation
Fan	Thermostat ON unit	Remote controller setting
	Stopping unit	OFF
	Thermostat OFF unit	OFF
Electronic expansion valve	Thermostat ON unit	Normal opening
	Stopping unit	200 pls
	Thermostat OFF unit	200 pls

(2) Oil Return Operation in Heating**[Start conditions]**

Referring to the set conditions for the following items, start the oil return operation in heating.

- 2 hours after initial power ON
- A lapse of every 1 ~ 2 hours during low-load operation
- A lapse of every 8 hours during high-load operation

Part Name	Electric Symbol			Oil return operation
	RQYQ8P	PQYQ10-12P	PQYQ14-16P	
Compressor	M1C	M1C	M1C	124Hz
	–	M2C	M2C	ON
	–	–	M3C	OFF
Outdoor unit fan	M1F	M1F	M1F, M2F	OFF → High pressure control
Four way valve	Y3S	Y3S	Y3S	OFF
Electronic expansion valve (Main)	Y1E	Y1E	Y1E	480 pls
Electronic expansion valve (Main 2)	–	–	Y2E	
Electronic expansion valve (Subcooling)	Y2E	Y2E	Y3E	0 pls
Solenoid valve (Hot gas)	Y1S	Y1S	Y1S	ON
Solenoid valve (Receiver gas vent)	Y8S	Y8S	Y8S	OFF
Solenoid valve (Circuit of oil return)	Y5S	Y5S	Y5S	OFF
Solenoid valve (Close liquid pipe for stopped outdoor unit)	Y6S	Y6S	Y6S	ON
Solenoid valve (Main electronic expansion valve bypass)	Y10S	Y10S	–	ON
Solenoid valve (Refrigerant regulator gas vent pipe)	Y11S	Y11S	Y10S	OFF
Solenoid valve (Refrigerant regulator liquid pipe)	Y12S	Y12S	Y11S	OFF
Solenoid valve (Refrigerant regulator gas pipe)	Y13S	Y13S	Y12S	OFF
Solenoid valve (Refrigerant regulator liquid outlet)	Y14S	Y14S	Y13S	OFF
Solenoid valve (Receiver liquid level)	Y7S	Y7S	Y7S	OFF
Solenoid valve (Mixing unit inlet)	Y4S	Y4S	Y4S	OFF
Solenoid valve (Bypass)	Y2S	Y2S	Y2S	OFF
Solenoid valve (Oil regulator outlet)	Y9S	Y9S	Y9S	ON

* In the case of multi-outdoor-unit system,

Master unit: Performs the operations listed in the table above.

Slave units: Operating units perform the operations listed in the table above.

Non-operating units perform the operations listed in the table above from the oil return operation.
(Non-operating unit stops during “oil return preparation operation”.)

Indoor unit actuator		Heating oil return operation
Fan	Thermostat ON unit	OFF
	Stopping unit	OFF
	Thermostat OFF unit	OFF
Electronic expansion valve	Thermostat ON unit	512 pls
	Stopping unit	512 pls
	Thermostat OFF unit	512 pls

2.6.2 Defrost Operation

To defrost the outdoor unit heat exchanger while in heating operation, the defrost operation is conducted to recover the heating capacity.

[Start conditions]

Referring to the set conditions for the following items, start the defrosting operation.

- A lapse of every 1 hour during high-load operation
- A lapse of every 2 hours during low-load operation

Part Name	Electric Symbol			Defrost operation
	RQYQ8P	PQYQ10-12P	PQYQ14-16P	
Compressor	M1C	M1C	M1C	143Hz
	–	M2C	M2C	ON
	–	–	M3C	ON
Outdoor unit fan	M1F	M1F	M1F, M2F	OFF
Four way valve	Y3S	Y3S	Y3S	OFF
Electronic expansion valve (Main)	Y1E	Y1E	Y1E	480 pls
Electronic expansion valve (Main 2)	–	–	Y2E	
Electronic expansion valve (Subcooling)	Y2E	Y2E	Y3E	0 pls
Solenoid valve (Hot gas)	Y1S	Y1S	Y1S	ON
Solenoid valve (Receiver gas vent)	Y8S	Y8S	Y8S	ON
Solenoid valve (Circuit of oil return)	Y5S	Y5S	Y5S	OFF
Solenoid valve (Close liquid pipe for stopped outdoor unit)	Y6S	Y6S	Y6S	ON
Solenoid valve (Main electronic expansion valve bypass)	Y10S	Y10S	–	ON
Solenoid valve (Refrigerant regulator gas vent pipe)	Y11S	Y11S	Y10S	OFF
Solenoid valve (Refrigerant regulator liquid pipe)	Y12S	Y12S	Y11S	OFF
Solenoid valve (Refrigerant regulator gas pipe)	Y13S	Y13S	Y12S	OFF
Solenoid valve (Refrigerant regulator liquid outlet)	Y14S	Y14S	Y13S	OFF
Solenoid valve (Receiver liquid level)	Y7S	Y7S	Y7S	OFF
Solenoid valve (Mixing unit inlet)	Y4S	Y4S	Y4S	OFF
Solenoid valve (Bypass)	Y2S	Y2S	Y2S	OFF
Solenoid valve (Oil regulator outlet)	Y9S	Y9S	Y9S	ON

* In the case of multi-outdoor-unit system,

Master unit: Performs the operations listed in the table above.

Slave units: Operating units perform the operations listed in the table above.

Non-operating units perform the operations listed in the table above from the oil return operation.
(Non-operating unit stops during “oil return preparation operation”.)

Indoor unit actuator		During defrost
Fan	Thermostat ON unit	OFF
	Stopping unit	OFF
	Thermostat OFF unit	OFF
Electronic expansion valve	Thermostat ON unit	512 pls
	Stopping unit	512 pls
	Thermostat OFF unit	512 pls

Part 5

Test Operation

1. Test Operation	61
1.1 Procedure and Outline	61
1.2 Check Operation	64
1.3 Checking in Normal Operation	67
2. Field Setting from Outdoor Unit.....	68
2.1 Field Setting from Outdoor Unit.....	68

1. Test Operation

1.1 Procedure and Outline

Follow the following procedure to conduct the initial test operation after installation.

1.1.1 Check work prior to turn power supply on

Check that the installation work for the indoor and outdoor units has been performed in accordance with the instructions in the Installation Manual.

Check the below items.

- Power wiring
- Control transmission wiring between units
- Earth wire
- Branch switch
- Earth leakage circuit breaker



- Is the wiring performed as specified?
- Are the branch switches and earth leakage circuit breakers wired correctly?
- Is the designated wire used?
- Is the wiring screw of wiring not loose?
- Is the grounding work completed?
- Is the insulation of the main power supply circuit deteriorated?
Use a 500V megger tester to measure the insulation. (*1)
- Do not use a megger tester for other circuits than 400V or 200V circuit.

*1: Measure to be taken against decreased insulation resistance in the compressor

If the compressor is left to stand for an extended period of time after the refrigerant charge with the stop valve open and the power supply OFF, the refrigerant may be mixed in the compressor, thus decreasing the insulation resistance.

Heat the compressor as shown on the right and then recheck the insulation.

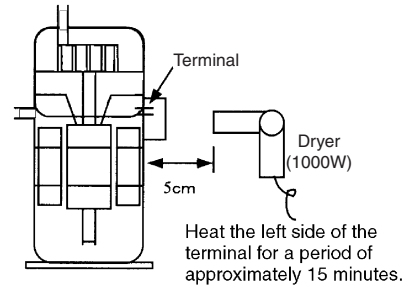

Check on refrigerant piping / insulation materials



- Is the pipe size proper? Are the design pressures for the gas pipe and liquid pipe more than 3.3MPa?
- Is the pipe insulation material installed securely?
Liquid and gas pipes need to be insulated. (Otherwise causes water leak.)

Check air tight test and vacuum drying.



- Have the air tight test and the vacuum drying been conducted according to the procedure in the Installation Manual?

Check on amount of additional refrigerant charge



- Is a proper quantity of refrigerant charged?
* Refer to the following page for the calculation of the amount of additionally refrigerant charge.
- When the refrigerant level is insufficient, leave the liquid and gas stop valves closed and charge with liquid refrigerant via the liquid stop valve service port. (* Do not charge via the gas stop valve service port. Doing so will result in error.)
- Is the amount of additional refrigerant charge recorded in the [Service Precaution] label?

Check the stop valves for conditions.

- Check to be sure the stop valves are under the following conditions.

Model	Liquid side stop valve	Gas side stop valve
RQYQ8-48PY1B	Open	Open

* How to calculate additional refrigerant charging amount (Unit: 0.1 kg)

$$R = \left[\left(\frac{\text{Total length of } \phi 22.2\text{-mm liquid pipe}}{\text{Total length of } \phi 22.2\text{-mm liquid pipe}} \right) \times 0.37 + \left(\frac{\text{Total length of } \phi 19.1\text{-mm liquid pipe}}{\text{Total length of } \phi 19.1\text{-mm liquid pipe}} \right) \times 0.26 + \left(\frac{\text{Total length of } \phi 15.9\text{-mm liquid pipe}}{\text{Total length of } \phi 15.9\text{-mm liquid pipe}} \right) \times 0.18 + \left(\frac{\text{Total length of } \phi 12.7\text{-mm liquid pipe}}{\text{Total length of } \phi 12.7\text{-mm liquid pipe}} \right) \times 0.12 + \left(\frac{\text{Total length of } \phi 9.5\text{-mm liquid pipe}}{\text{Total length of } \phi 9.5\text{-mm liquid pipe}} \right) \times 0.059 + \left(\frac{\text{Total length of } \phi 6.4\text{-mm liquid pipe}}{\text{Total length of } \phi 6.4\text{-mm liquid pipe}} \right) \times 0.022 \right] \times A$$

+ B (Correction with outdoor unit capacity) + C (Correction with indoor unit capacity)

Model		A	B kg	C kg	
				≤100%	>100%
RQYQ	8PY1B	1.00	-6.8kg	0.0kg	0.0kg
	10PY1B		-7.9kg		
	12PY1B		-9.3kg		
	14.16PY1B		-14.1kg		

1.1.2 Turn power on

Turn outdoor unit and indoor unit power on.



Check the LED display of the outdoor unit PCB.



Make field settings with outdoor unit PCB.

○ Be sure to turn the power on 6 hours before starting operation to protect compressors. (to power on crankcase heater)

○ Check to be sure the transmission is normal. The transmission is normal if the LEDs display conditions as shown in table below.

LED display ○ ON ● OFF ● Blinking

LED display (Default status before delivery)	Micro-computer operation monitor	MODE	TEST	COOL / HEAT select			Low noise	Demand	Multi
				IND	MASTER	SLAVE			
				H3P	H4P	H5P			
One outdoor unit installed	●	●	●	○	●	●	●	●	●
When multiple outdoor unit installed (*)	Master	●	●	●	○	●	●	●	○
	Slave 1	●	●	●	●	●	●	●	●
	Slave 2	●	●	●	●	●	●	●	●
	Slave 3	●	●	●	●	●	●	●	●

(*) The master unit is the outdoor unit to which the transmission wiring for the indoor units is connected. The other outdoor units are slave units.

○ Make field settings if needed. (For the setting procedure, refer to information in "Field Setting from Outdoor Unit" on P. 68 onward.) For the outdoor-multi system, make field settings with the master unit. (Field settings made with the slave unit will be all invalid.)

[Outdoor unit]

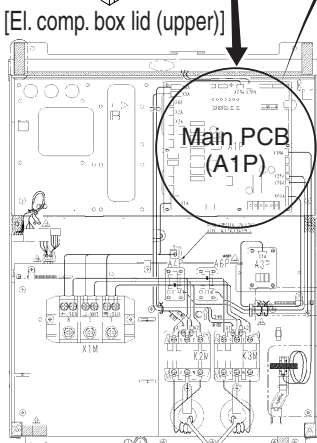
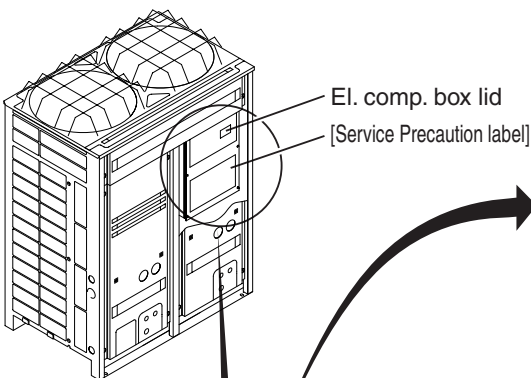

[Main PCB]

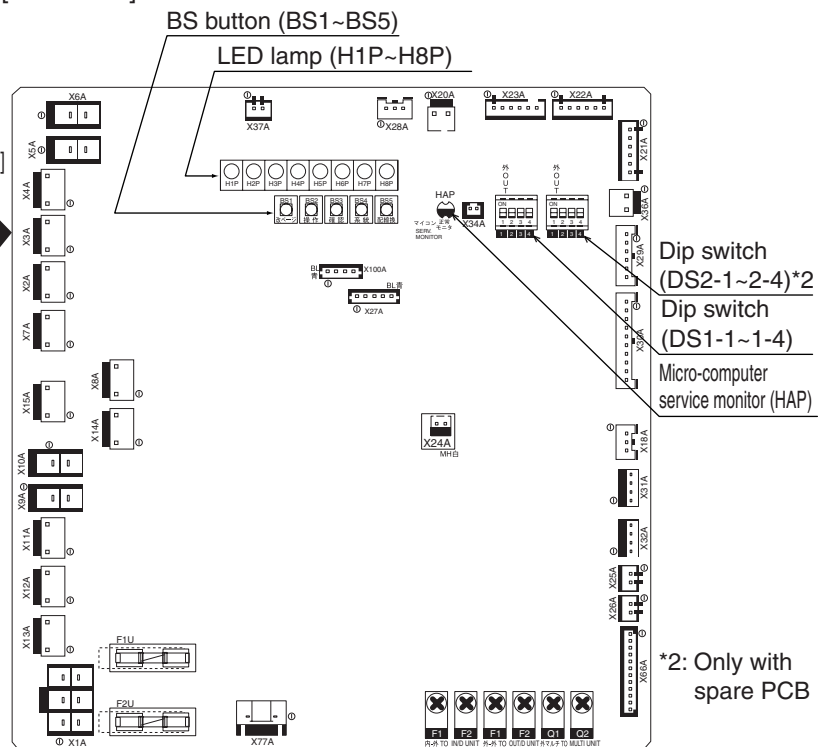

1.2 Check Operation

1.2.1 RQYQ-P

- Make sure to carry out the check operation after the initial installation. Otherwise, the error code "U3" will be displayed on the remote controller and normal operation cannot be carried out.
- In the check operation, the following checks and judgement will be performed:
 - (1) Check of the stop valve opening
 - (2) Check for wrong wiring
 - (3) Recovery of contamination
 - (4) Check of the amount of refrigerant
 - (5) Automatic judgement of piping length
- The automatic check operation carries out the following processes. Approximately 70 minutes (maximum 120 minutes) are required before judgement is completed. However if additional charging from the refrigerant cylinder is necessary, additional time will be required.

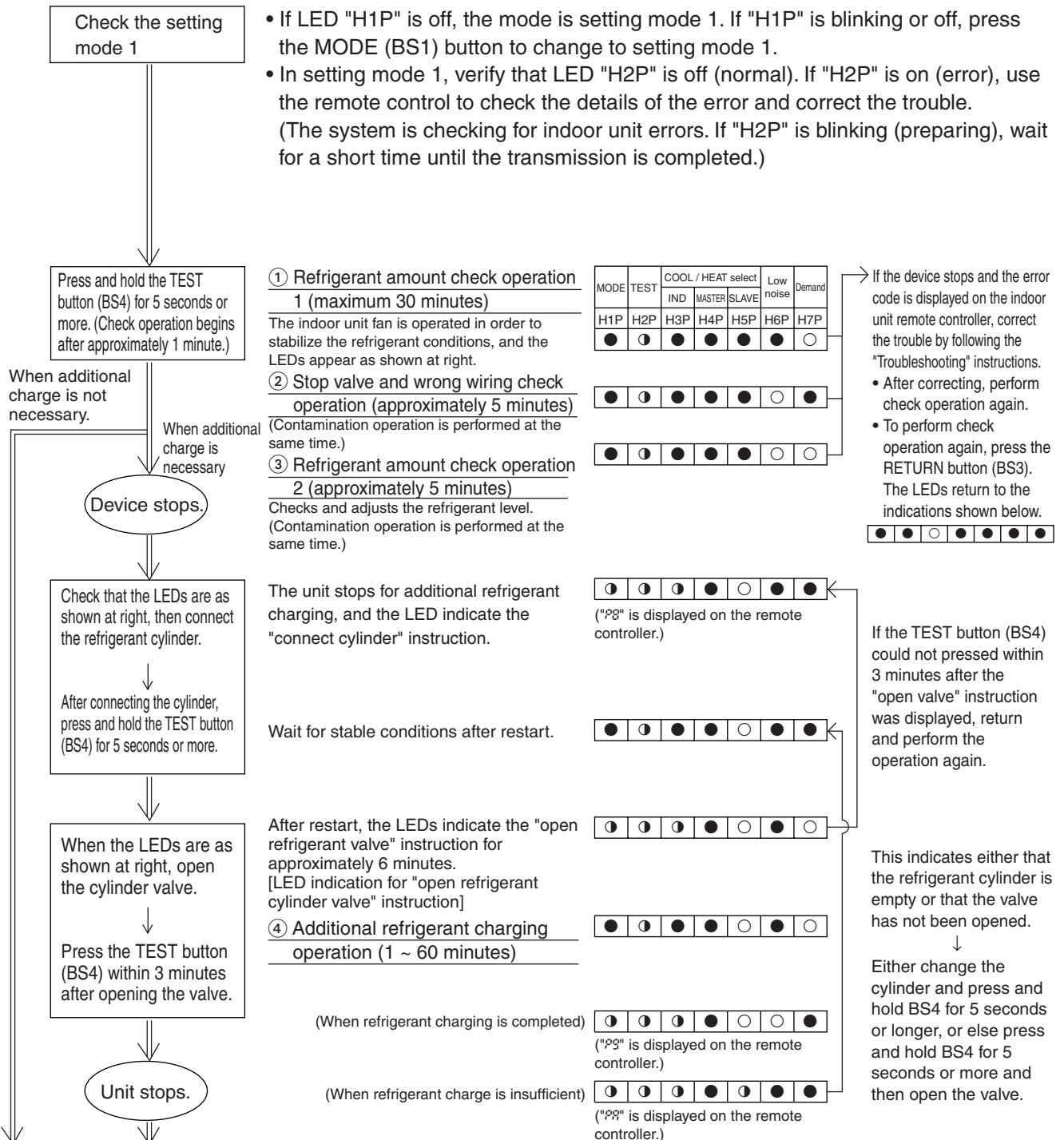

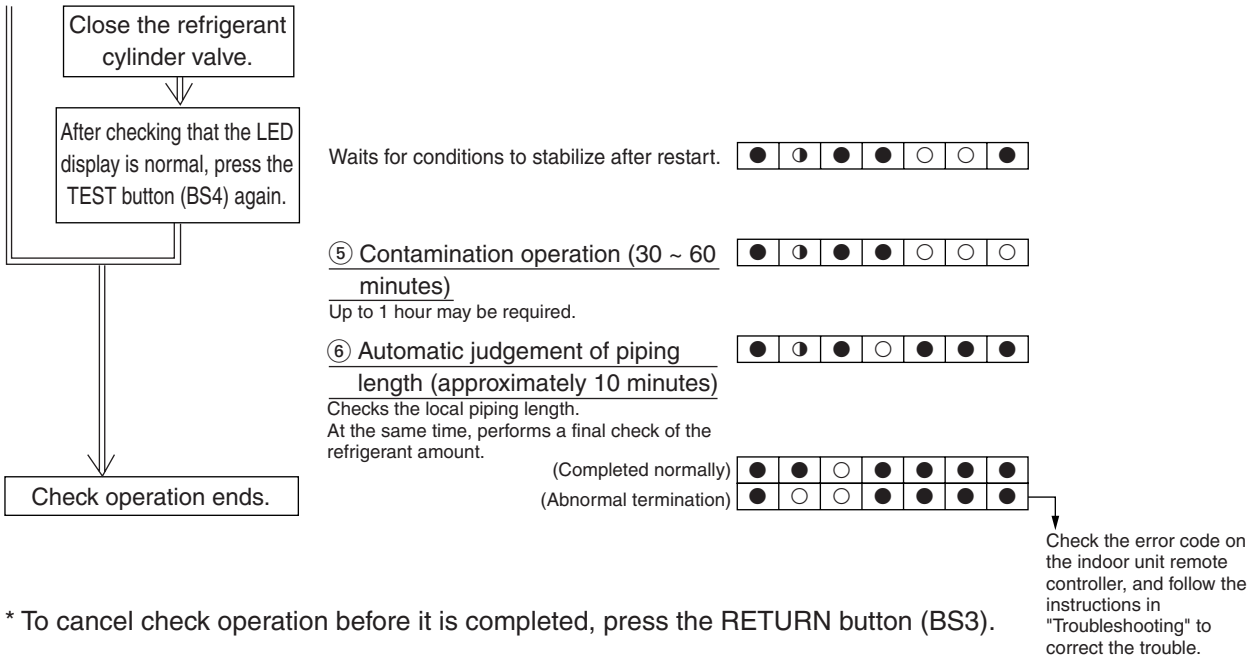

* To cancel check operation before it is completed, press the RETURN button (BS3).

[Remote controller displays error code]

Error code	Installation trouble	Corrective action
E3 F3 E4 UF	The outdoor unit stop valve has not been opened.	Check that the gas and liquid side stop valves are open.
P8 P9 PA	Instruction to perform additional refrigerant charging during check operation (not an error)	Follow the procedure for check operation (refer to the previous page) and perform additional refrigerant charge.
PJ	DIP switch (DS1, DS2) setting is incorrect after the outdoor unit PCB (A1P) was replaced.	Follow the instructions in "Field setting from outdoor unit" (refer to P.68) and make the correct setting.
U1	Phase of outdoor unit power is reversed.	Reverse 2 of the 3 phases and connect with the correct phases.
U3	Check operation has not been completed normally.	Perform check operation again.
U4	Power is not being supplied (including cases of open phase) to an outdoor unit or indoor unit.	Supply power correctly to the outdoor units and indoor units.
U7 UA	A model which cannot be connected in a multi-outdoor-unit system has been connected in a multi-outdoor-unit system.	Change to individual piping, and disconnect the wiring from the multi-outdoor-unit terminals (Q1, Q2).
U9	There is trouble at another indoor unit within the same system.	An error code is displayed on the remote controller, or else trouble has occurred at an indoor unit where an error code is not displayed on the remote controller. Correct the trouble at the corresponding indoor unit. If no error code is displayed on the remote controller, press the INSPECTION/TEST button on the remote controller to display the error code. Check that the refrigerant piping system and interunit wiring connections match.
UF	Wrong connection in piping or wiring between units.	Complete the transmission wiring work, then perform check operation again.
	If an outdoor - outdoor transmission wire was connected or disconnected during check operation	Connect the interunit wiring (cool/heat select remote controller, inside-outside, outside-outside, multi-outside-unit).
UH	Wrong wiring between units	If voltage of 100V or higher was applied to the outdoor unit PCB (A1P), the outdoor unit PCB or indoor unit PCB may be damaged. If the error display "UH" appears even after the connection was corrected, the PCB must be replaced.

1.3 Checking in Normal Operation

■ **After check operation ends, start normal operation.**

(Heating is not possible if the outdoor air temperature is 24°C or higher.)

- Check that the indoor and outdoor units are operating normally.
(If any abnormal noise occurs due to liquid compression in the compressor or another cause, stop operation immediately. Then energize the crankcase heater for a sufficient period of time before restarting operation.)
- Start the indoor units one by one. Verify that the corresponding outdoor unit is operating.
- Verify that cool air (or warm air) is being discharged by the indoor unit.
- Press the airflow direction button and airflow rate button of the indoor unit and verify their operation.

<Important information when checking normal operation>

- If any abnormal noise occurs due to liquid compression in the compressor or another cause, stop operation immediately. Then energize the crankcase heater for a sufficient period of time before restarting operation.
- For approximately 5 minutes after the compressor is stopped, the compressor will not start even when the ON/OFF buttons at indoor units in that system are pressed.
- Pump down residual operation may occur for up to 5 minutes at the outdoor unit after operation was stopped from the remote controller.
- Outdoor unit fan low speed operation may also occur if the Low night noise setting or the External low noise setting is used.
- If check operation after installation was not performed by pressing the TEST button, or if the check operation was not completed normally, error code "U3" is displayed and normal operation is not possible. Be sure to follow the instructions in "1-2. Check Operation" and complete the check operation procedure.

2. Field Setting from Outdoor Unit

2.1 Field Setting from Outdoor Unit

2.1.1 List of Field Setting Items

This following section indicates the list of field setting items. For the lists of DIP switch contents, Setting mode 1, and Setting mode 2, refer to information in tables shown on the following page onward.

(1) Function setting items

Setting item	Content and objective of setting	Overview of setting procedure
1 Setting of COOL/HEAT selector	<ul style="list-style-type: none"> ■ COOL/HEAT selector methods are possible to select from the following <ol style="list-style-type: none"> (1) Control by each outdoor unit using the indoor unit remote controller (2) Control by each outdoor unit using the COOL/HEAT selector remote controller (3) Batch control by outdoor unit group using the indoor unit remote controller (4) Batch control by outdoor unit group using the COOL/HEAT selector remote controller (5) Outdoor unit systems control using the centralized remote controller 	<ul style="list-style-type: none"> ■ In order to use the COOL/HEAT selector remote controller, set the DS1-1 on the outdoor unit PCB to OUT. ■ For outdoor unit group control, set the system to "BATCH MASTER" or "SLAVE" while in "Setting mode 1". Then, make setting of COOL/HEAT batch address.
2 Setting of low noise operation	A. Use external input to step down the upper limit of the fan (factory set to Step 8), providing low noise level. <ol style="list-style-type: none"> (1) Mode 1: Step 6 or lower (2) Mode 2: Step 5 or lower (3) Mode 3: Step 4 or lower 	<ul style="list-style-type: none"> ■ Use the "External control adaptor for outdoor unit". Set to "External control adaptor for outdoor unit" with No. 12 of "Setting mode 2" and select the mode with No. 25. If necessary, set the "Capacity precedence setting" to ON with No. 29.
	B. The low noise operation aforementioned is enabled in low night noise operation mode. Start time: Possible to select in the range of 20:00 to 24:00 hours. End time: Possible to select in the range of 06:00 to 08:00 hours. (Use the said time as a guide since the start time and the end time are estimated according to outdoor air temperatures.)	<ul style="list-style-type: none"> ■ Make this setting while in "Setting mode 2". Select a mode with No. 22 of "Setting mode 2". Select the start time with No. 26 and the end time with No. 27. If necessary, set the "Capacity priority setting" to ON with No. 29.
3 Setting of demand operation	<ul style="list-style-type: none"> ■ Used to place limits on the compressor operating frequency to control the upper limit of power consumption. <ol style="list-style-type: none"> (1) Mode 1 of Demand 1: 60% or less of rating (2) Mode 2 of Demand 1: 70% or less of rating (3) Mode 3 of Demand 1: 80% or less of rating (4) Demand 2: 40% or less of rating (5) Demand 3: Forced thermostat OFF 	<ul style="list-style-type: none"> ■ Method of using the external control adaptor for outdoor unit. Select Demand 1 – 3 by short circuit the terminal strip (TeS1).
		<ul style="list-style-type: none"> ■ Setting by "Setting mode 2" only. Select Demand 1 or Demand 2 using set No. 32 of "Setting mode 2". If Demand 1 is selected, then also select Level 1 – 3 using set No. 30.
4 Setting of AIRNET address	<ul style="list-style-type: none"> ■ Used to make address setting with AIRNET connected. 	<ul style="list-style-type: none"> ■ Set the AIRNET to an intended address using binary numbers with No. 13 of "Setting mode 2".
5 Setting of hot water	<ul style="list-style-type: none"> ■ Make this setting to conduct heating operation with hot water heater. 	<ul style="list-style-type: none"> ■ Set No. 16 of "Setting mode 2" to ON.
6 Setting of high static pressure	<ul style="list-style-type: none"> ■ Make this setting to operate a system with discharge duct while in high static pressure mode. (Use this setting mode when concealed outdoor unit installation is required on upper floors or balconies.) * In order to mount the discharge duct, remove the cover from the outdoor unit fan. 	<ul style="list-style-type: none"> ■ Set No. 18 of "Setting mode 2" to ON.

(2) Service setting items

Setting item		Content and objective of setting	Overview of setting procedure
1	Indoor unit fan forced H operation	■ Used to operate the indoor unit in the stopped state in forced H operation mode.	■ Set No. 5 of "Setting mode 2" to indoor unit forced fan H.
2	Indoor unit forced operation	■ Used to operate the indoor unit in forced operation mode.	■ Set No. 6 of "Setting mode 2" to indoor unit forced operation mode.
3	Change of targeted evaporation temperature (in cooling)	■ In cooling operation, used to change the targeted evaporation temperature for compressor capacity control.	■ Select high side or low side with No. 8 of "Setting mode 2".
4	Change of targeted condensing temperature (in heating)	■ In heating operation, used to change the targeted condensing temperature for compressor capacity control.	■ Select high side or low side with No. 9 of "Setting mode 2".
5	Setting of defrost selection	■ Used to change a temperature at which the defrost operation is initiated, thus making the initiation easy or hard.	■ Select fast side or slow side with No. 10 of "Setting mode 2".
6	Setting of sequential startup	■ Used to start units not in sequence but simultaneously.	■ Set No. 11 of "Setting mode 2" to NONE.
7	Emergency operation	■ If the compressor has a failure, used to prohibit the operation of compressor(s) concerned or outdoor unit(s) concerned and to conduct emergency operation of the system only with operable compressor(s) or outdoor unit(s).	■ Make this setting while in "Setting mode 2". For system with a single outdoor unit: Set with No. 19 or 42. For system with multiple outdoor units: Set with No. 38 or 39.
8	Air tight test	■ Fully open the outdoor unit and indoor unit expansion valves, and turn on some of the solenoid valves.	■ Set No. 21 of "Setting mode 2" to ON.
9	Refrigerant recovery mode	■ Used to recover refrigerant onsite. With operations of indoor and outdoor units prohibited, fully open the expansion valve of the indoor and outdoor units.	■ Set No. 21 of "Setting mode 2" to ON.
10	Vacuuming mode	■ Used to conduct vacuuming onsite. Fully open the expansion valves of the indoor and outdoor units, and energize some of solenoid valves. Use a vacuum pump to conduct vacuuming.	■ Set No. 21 of "Setting mode 2" to ON.
11	Power transistor check mode	■ Used for the troubleshooting of DC compressors. Inverter waveform output makes it possible to judge whether an error results from the compressor or the PCB.	■ Set No. 28 of "Setting mode 2" to ON.
12	Setting of model with spare PCB	■ In order to replace the PCB by a spare one, be sure to make model setting.	■ For this setting, set the DS2-2, -3, and-4 switches on the PCB to the model concerned.

2.1.2 Setting by DIP switches

(1) Setting of factory set

Using DIP switches on the PCB enables field setting shown below. However, make no changes of factory settings except for DS1-1.

DIP switch		Setting item	Description
No.	Setting		
DS1-1	ON	Cool / Heat select	COOL/HEAT select setting is made with the use of a Cool/Heat selector equipped with the outdoor unit.
	OFF (Factory setting)		
DS1-2 ~DS1-4	ON	Not used	Do not change the factory settings.
	OFF (Factory setting)		

(2) Setting at replacement by spare PCB



Caution

DIP switch Setting after replacing the main PCB (A1P) to spare PCB

After the replacement by the spare PCB, be sure to make settings shown below. When you replace the main PCB (A1P) to spare PCB, please carry out the following setting.

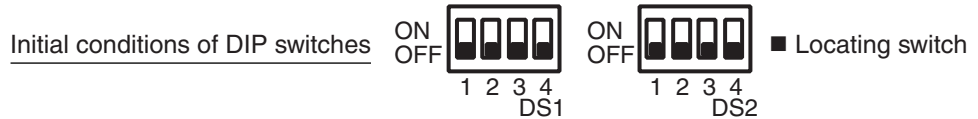

DS No.	Item	Contents				
DS1-1	Cool/Heat select setting	ON	COOL/HEAT select setting is made with the use of a Cool/Heat selector equipped with the outdoor unit.			
		OFF (Factory setting of spare PCB)	COOL/HEAT select setting is not made with the use of a Cool/Heat selector equipped with the outdoor unit.			
DS1-2	Power supply specification	ON	220V			
		OFF (Factory setting of spare PCB)	380V			
DS1-3	Cooling Only/ Heat-Pump setting	ON	Cooling Only setting			
		OFF (Factory setting of spare PCB)	Heat Pump setting			
DS1-4	Check operation	ON	(1) If check operation was not performed during installation → Do not change the setting. (Leave it OFF.)			
		OFF (Factory setting of spare PCB)	(2) If check operation was completed or normal operation is in progress → Change the setting (OFF → ON).			
DS2-1	Unit allocation setting (Domestic / Overseas)	ON	Do not change factory setting of the spare part (OFF).			
		OFF (Factory setting of spare PCB)				
DS2-2	Model setting	Make the following settings according to models of outdoor units.				
DS2-3		RQYQ8PY1B	RQYQ10PY1B	RQYQ12PY1B	RQYQ14PY1B	RQYQ16PY1B
DS2-4		OFF	ON	OFF	ON	OFF
		ON	ON	OFF	OFF	ON
		OFF	OFF	ON	ON	ON

2.1.3 Setting by BS button

The following settings are made by BS button on PCB.

In case of multi-outdoor unit system, various items should be set with the master unit.

(Setting with the slave unit is disabled.)

LED display

	MODE H1P	TEST H2P	COOL/HEAT select			Low noise H6P	Demand H7P	Multi; H8P
			IND H3P	MASTER H4P	SLAVE H5P			
Single-outdoor-unit system	●	●	○	●	●	●	●	●
Outdoor- multi system	Master	●	○	●	●	●	●	○
	Slave 1 ~ 4	●	●	●	●	●	●	●

(Factory setting)

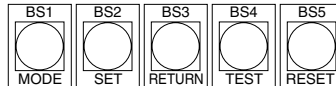

There are the following three setting modes.

① **Setting mode 1 (H1P OFF)**

Initial status (when normal): Used to select the cool/heat setting. Also indicates during “abnormal”, “low noise control” and “demand control”.

② **Setting mode 2 (H1P ON)**

Used to modify the operating status and to set program addresses, etc. Usually used in servicing the system.

③ **Monitor mode (H1P blinks)**

Used to check the program made in Setting mode 2.

■ **Mode changing procedure 1**

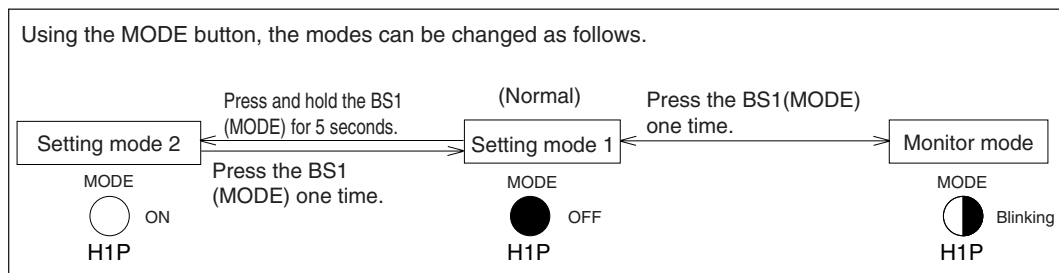

a. "Setting mode 1"

This mode is used to set and check the following items.

1. Set items In order to make COOL/HEAT selection in a batch of outdoor unit group, change the setting.
 - COOL/HEAT selector (IND)..... Used to select COOL or HEAT by individual outdoor unit (factory set).
 - COOL/HEAT selector (MASTER)..... Used to select COOL or HEAT by outdoor unit group with the master unit.
 - COOL/HEAT selector (SLAVE) Used to select COOL or HEAT by outdoor unit group with the slave unit.
2. Check items The following items can be checked.
 - (1) Current operating conditions (Normal / Abnormal / In check operation)
 - (2) Setting conditions of COOL/HEAT selection (Individual / Batch master / Batch slave)
 - (3) Low noise operating conditions (In normal operation / In low night noise operation)
 - (4) Demand operating conditions (In normal operation / In demand operation)

Procedure for changing COOL/HEAT selection setting

Normally, "Setting mode 1" is set. In case of other status, press [MODE (BS1)] button one time and set to "Setting mode 1".

Press the [SET (BS2)] button to set the blinking of LED to any of conditions shown on the right.

Press the [RETURN (BS3)] button to determine the setting.

Setting (displaying) item	MODE H1P	TEST H2P	COOL/HEAT select			Low noise H6P	Demand H7P
			IND H3P	MASTER H4P	SLAVE H5P		
For selection by individual outdoor unit (factory setting)	●	●	◐	●	●	●	●
For selection in a batch of outdoor unit group with master unit	●	●	●	◐	●	●	●
For selection in a batch of outdoor unit group with slave unit	●	●	●	●	◐	●	●

○ ON
● OFF
◐ Blink

Pressing the [RETURN (BS3)] button will return the system to the initial condition of "Setting mode 1".

Procedure for checking check items

The system is normally set to "Setting mode 1". Should the system be set to any mode other than that, press the [MODE (BS1)] button to set the system to "Setting mode 1".

Check the system for each condition through LED displays. (Refer to information in table on the right.)

Pressing the [RETURN (BS3)] button will bring the system to the initial state of "Setting mode 1".

MODE H1P	TEST H2P	COOL/HEAT select			Low noise H6P	Demand H7P
		IND H3P	MASTER H4P	SLAVE H5P		
●	●	○	●	●	●	●

- ▶ Current operating conditions
 - Normal ○ Abnormal
 - ◐ In preparation or in check operation
- ▶ Setting of COOL/HEAT selection
 - By individual outdoor unit
 - In a batch of outdoor unit group with master unit
 - In a batch of outdoor unit group with slave unit
- ▶ Low noise operating conditions
 - In normal operation
 - In low noise operation
- ▶ Demand operating conditions
 - In normal operation
 - In demand operation

b. "Setting mode 2"

Press and hold the **MODE (BS1)** button for 5 seconds and set to "Setting mode 2".

<Selection of setting items>

Press the **SET (BS2)** button and set the LED display to a setting item shown in the table on the right.

↓
Press the **RETURN (BS3)** button and decide the item. (The present setting condition is blinked.)

<Selection of setting conditions>

Press the **SET (BS2)** button and set to the setting condition you want.

↓
Press the **RETURN (BS3)** button and decide the condition.

Press the **RETURN (BS3)** button and set to the initial status of "Setting mode 2".

No.	Setting item	Description
0	Digital pressure gauge kit display	Used to make setting of contents to display on the digital pressure gauges (e.g. pressure sensors and temperature sensors)
1	Cool/heat unified address	Sets address for cool/heat unified operation.
2	Low noise/demand address	Address for low noise/demand operation
3	Test operation settings	Used to conduct test operation without making changes to the PCB and replacing the refrigerant, after the completion of maintenance.
5	Indoor unit forced fan H	Allows forced operation of indoor unit fan while unit is stopped. (H tap)
6	Indoor unit forced operation	Allows forced operation of indoor unit. (Forced thermostat ON)
8	Te setting	Target evaporation temperature for cooling
9	Tc setting	Target condensation temperature for heating
10	Defrost changeover setting	Changes the temperature condition for defrost and sets to quick defrost or slow defrost.
11	Sequential operation setting	Sets sequential operation (Factory setting to ON)
12	External low noise setting / Demand setting	Reception of external low noise or demand signal
13	Setting of AIRNET address	Set the address for AIRNET.
16	Setting of hot water	Make this setting to conduct heating operation with hot water heater.
18	High static pressure setting	Make this setting in the case of operating in high static pressure mode with diffuser duct mounted. (In order to mount the diffuser duct, remove the cover from the outdoor unit fan.)
19	Emergency operation	If the compress has a failure, used to prohibit the operation of STD compressor and to conduct emergency operation of the system with other compressor.
20	Additional refrigerant charging operation setting	Carries out additional refrigerant charging operation.
21	Refrigerant recovery/vacuuming mode setting	Sets to refrigerant recovery or vacuuming mode.
22	Low night noise setting	Sets automatic low night noise operation in a simple way. The operating time is based on "Starting set" and "Ending set".
25	Setting of external low noise level	Sets low noise level when the low noise signal is input from outside.
26	Low night noise operation start setting	Sets starting time of low night noise operation. (Low night noise setting is also required.)
27	Low night noise operation end setting	Sets ending time of low night noise operation. (Low night noise setting is also required.)
28	Power transistor check mode *Check after disconnection of compressor wires	Used for trouble diagnosis of DC compressor. Since the waveform of inverter is output without wiring to the compressor, it is convenient to probe whether the trouble comes from the compressor or PCB.
29	Capacity priority setting	If the capacity control is required, the low noise control is automatically released by this setting during carrying out low noise operation and low night noise operation.
30	Demand setting 1	Changes target value of power consumption when demand control 1 is input.
32	Normal demand setting	Normally enables demand control 1 without external input. (Effective to prevent a problem that circuit breaker of small capacity is shut down due to large load.)

* If you become unsure of how to proceed, press the **MODE (BS1)** button and return to setting mode 1.

No.	Setting item	Description
35	Setting of difference in height for the outdoor unit	Make the setting when the outdoor unit is installed 40 m or more below the indoor unit.
38	Emergency operation (Setting for the master unit operation prohibition in multi-outdoor-unit system)	Used to temporarily prohibit the applicable outdoor unit from operating should there be any defective part in multi-outdoor-unit system. Since the comfortable environment is extremely impaired, prompt replacement of the part is required.
39	Emergency operation (Setting for the slave unit 1 and 2 operation prohibition in multi-outdoor-unit system)	
40	Emergency operation (Setting for the slave unit 3 operation prohibition in multi-outdoor-unit system)	
55	Master-slave set-up for multi outdoor units	Set up master and slave units for multi-connection outdoor units. After setting up, press the BS5 (RESET) button for 5 seconds or more.

↑ The numbers in the "No." column represent the number of times to press the SET (BS2) button.

c. Monitor mode

To enter the monitor mode, press the **MODE (BS1)** button when in "Setting mode 1".

<Selection of setting item>

Press the **SET (BS2)** button and set the LED display to a setting item.

<Confirmation on setting contents>

Press the **RETURN (BS3)** button to display different data of set items.

Press the **RETURN (BS3)** button and switches to the initial status of "Monitor mode".

* Press the **MODE (BS1)** button and returns to "Setting mode 1".

No.	Setting item	LED display							Data display
		H1P	H2P	H3P	H4P	H5P	H6P	H7P	
0	Various settings	●	●	●	●	●	●	●	Lower 4 digits
1	C/H unified address	●	●	●	●	●	●	○	Lower 6 digits
2	Low noise/demand address	●	●	●	●	●	○	●	
4	AIRNET address	●	●	●	●	○	●	●	
5	Number of connected indoor units *1	●	●	●	●	○	●	○	
6	Number of connected BS units	●	●	●	●	○	○	●	
7	Number of connected zone units (Fixed to "0")	●	●	●	●	○	○	○	
8	Number of outdoor units *2	●	●	●	○	●	●	●	
11	Number of zone units	●	●	●	○	●	○	○	
12	Number of terminal units *3	●	●	●	○	○	●	●	Lower 4 digits: upper
13	Number of terminal units *3	●	●	●	○	○	●	○	Lower 4 digits: lower
14	Contents of error (the latest)	●	●	●	○	○	○	●	Error code table
15	Contents of error (1 cycle before)	●	●	●	○	○	○	○	Refer to P. 100 ~ 103
16	Contents of error (2 cycle before)	●	●	○	●	●	●	●	
20	Contents of retry (the latest)	●	●	○	●	○	●	●	
21	Contents of retry (1 cycle before)	●	●	○	●	○	●	○	
22	Contents of retry (2 cycle before)	●	●	○	●	○	○	●	
25	Number of multi connection outdoor units	●	●	○	○	●	●	○	Lower 6 digits

The numbers in the "No." column represent the number of times to press the SET (BS2) button.

*1. Number of connected indoor units

Used to make setting of the number of indoor units connected to an outdoor unit.

*2. Number of outdoor units

Used to make setting of the number of outdoor units connected to DIII-NET that is one of the communication lines.

*3. Number of terminal units

Used to make setting of the number of indoor units connected to DIII-NET that is one of the communication lines.
(Only available for VRV indoor units)

Setting item 0 Display contents of “Number of units for various settings”

EMG operation / backup operation setting	ON	●	●	●	○	●	●	●
	OFF	●	●	●	●	●	●	●
Defrost select setting	Short	●	●	●	●	○	●	●
	Medium	●	●	●	●	●	○	●
	Long	●	●	●	●	●	●	●
Te setting	L	●	●	●	●	●	●	●
	M	●	●	●	●	●	○	●
	H ①~⑤	●	●	●	●	●	○	●
Tc setting	L	●	●	●	●	●	●	●
	M	●	●	●	●	●	●	○
	H	●	●	●	●	●	●	○

★ Data such as addresses and number of units is expressed as binary numbers; the two ways of expressing are as follows:

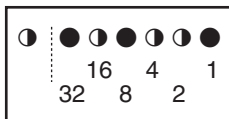

The No. 1 cool/heat unified address is expressed as a binary number consisting of the lower 6 digits. (0 - 63)

In ① the address is 010110 (binary number), which translates to $16 + 4 + 2 = 22$ (base 10 number). In other words, the address is 22.

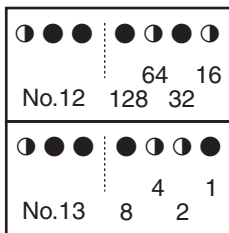

The number of terminal blocks for No. 12 and 13 is expressed as an 8-digit binary number, which is the combination of four upper, and four lower digits for No. 12 and 13 respectively. (0 - 128)

In ② the address for No. 12 is 0101, the address for No. 13 is 0110, and the combination of the two is 01010110 (binary number), which translates to $64 + 16 + 4 + 2 = 86$ (base 10 number). In other words, the number of terminal block is 86.

2.1.4 Cool / Heat Mode Selection

There are the following 5 cool/heat select modes.

- ① Set cool/heat separately for each outdoor unit system by indoor unit remote controller.
- ② Set cool/heat separately for each outdoor unit system by cool/heat selector.
- ③ Set cool/heat for more than one outdoor unit system simultaneously in accordance with unified master outdoor unit by indoor unit remote controller.
- ④ Set cool/heat for more than one outdoor unit system simultaneously in accordance with unified master outdoor unit by cool/heat select remote controller.
- ⑤ Set cool/heat at all outdoor unit systems simultaneously for each outdoor unit external control adaptor for outdoor unit by using the centralized remote controller.

① Set Cool / Heat Separately for Each Outdoor Unit System by Indoor Unit Remote Controller

- ◆ It does not matter whether or not there is outdoor - outdoor unit wiring.
- ◆ Set outdoor unit PCB DS1-1 to IN (factory setting).
- ◆ Set C/H select to IND (individual) for "Setting mode 1" (factory setting).

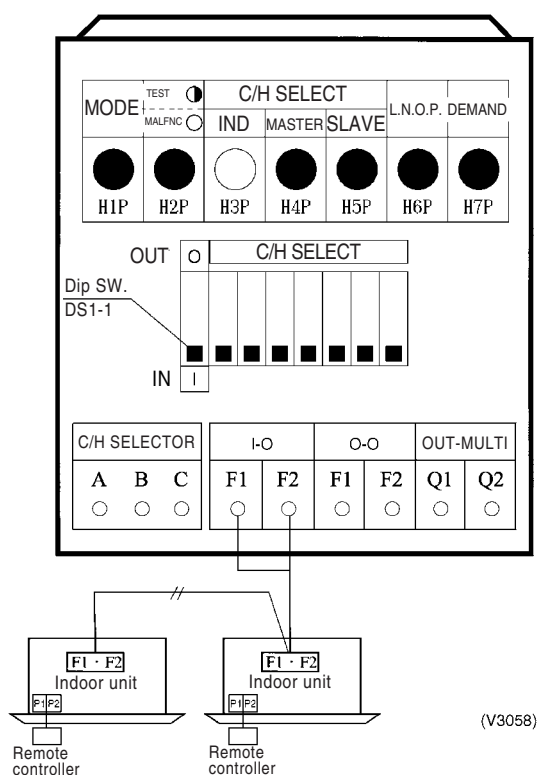

② Set Cool / Heat Separately for Each Outdoor Unit System by Cool / Heat Selector

- ◆ It does not matter whether or not there is outdoor - outdoor unit wiring.
- ◆ Set outdoor unit PCB DS1-1 to OUT (factory setting).
- ◆ Set C/H select to IND (individual) for "Setting mode 1" (factory setting).

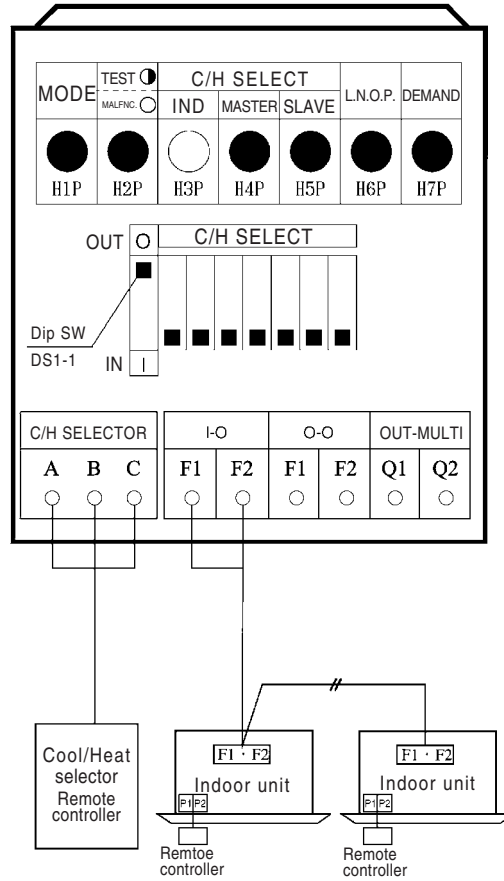

③ Set Cool / Heat for More Than One Outdoor Unit System Simultaneously in Accordance with Unified Master Outdoor Unit by Indoor Unit Remote Controller

- ◆ Install the external control adaptor for outdoor unit on either the outdoor-outdoor, indoor-outdoor transmission line.
- ◆ Set outdoor unit PCB DS1-1 to IN (factory setting).
- ◆ In setting mode 1, set the outdoor unit you want to give cool/heat selection permission to as the unified master, and set the other outdoor units as unified slave units.
- ◆ Set the external control adaptor for outdoor unit SS1 to BOTH (factory setting) or C/H, and SS2 to OFF (factory setting).

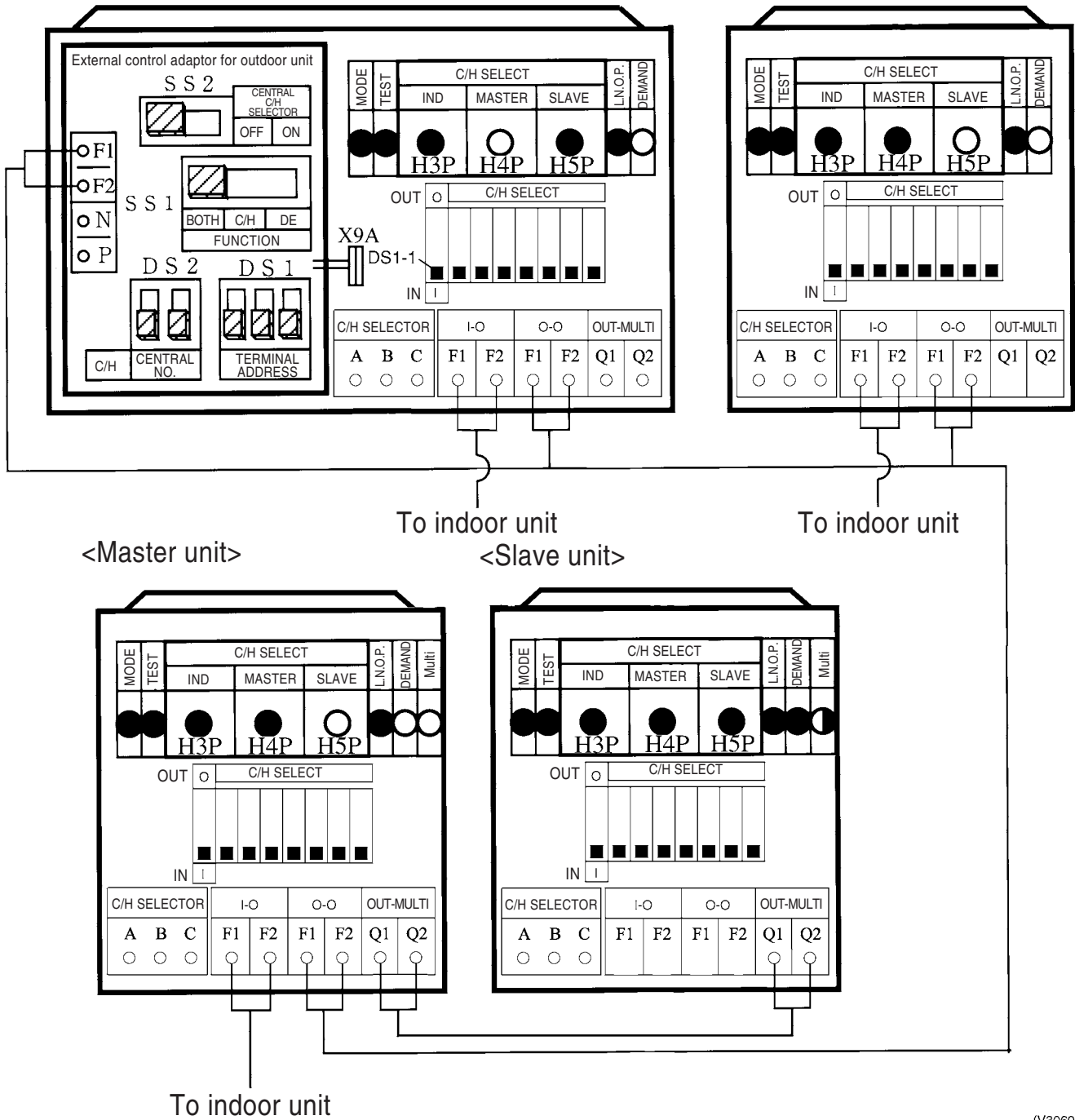

(V3060)

Multi outdoor units connection

- ◆ When multiple external control adaptors for outdoor unit are used and cool / heat is selected for each external control adaptor for outdoor unit, use “setting mode 2” and set DS1 and DS2 on the external control adaptors for outdoor unit and the unified cool / heat address on the outdoor unit main PCB to the same address No. (For details, refer to the following page.)

④ Set Cool / Heat for More Than One Outdoor Unit System Simultaneously in Accordance with Unified Master Outdoor Unit by Cool / Heat Select Remote Controller

- ◆ Install the external control adaptor for outdoor unit on either the outdoor-outdoor, indoor-outdoor transmission line.
- ◆ Mount the COOL/HEAT selector to the unified master outdoor unit.
- ◆ Set the DS1-1 on the PCB of unified master outdoor unit to OUT.
- ◆ In setting mode 1, set the outdoor unit you want to give cool/heat selection permission to as the unified master, and set the other outdoor units as unified slave units.
- ◆ When multiple external control adaptors for outdoor unit are used and cool / heat is selected for each external control adaptor for outdoor unit, use “setting mode 2” and set DS1 and DS2 on the external control adaptors for outdoor unit and the unified cool / heat address on the outdoor unit main PCB to the same address No. (For details, refer to the following page.).

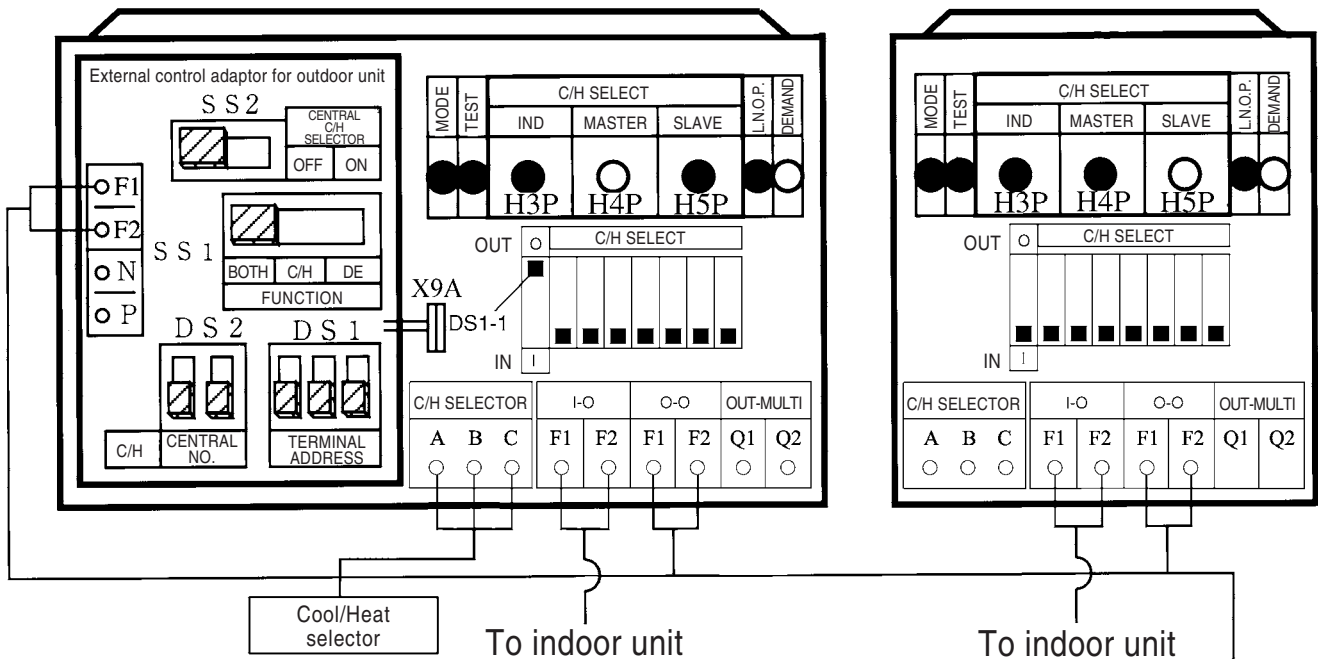

<Master unit>

<Slave unit>

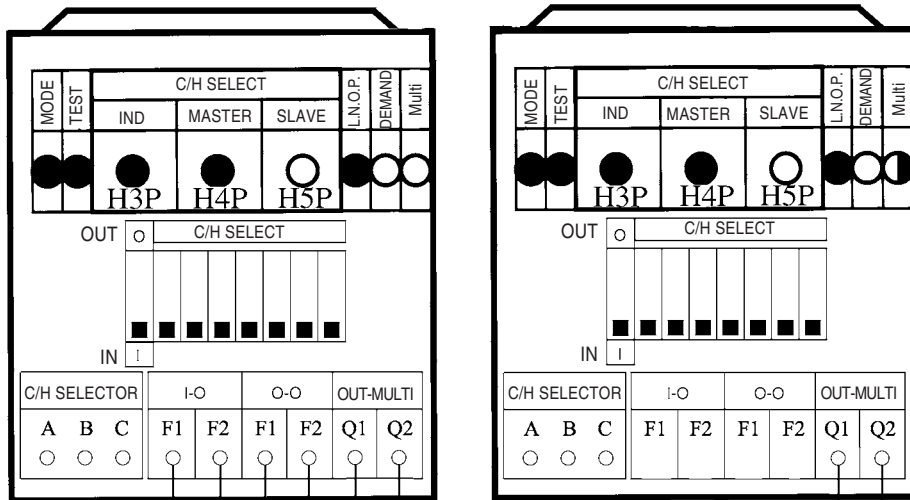

To indoor unit

Multi outdoor units connection

(V3060-1)

Supplementation on ③ and ④.

When switching cool/heat for each adaptor PCB with the use of more than one adaptor PCB, set the address of the external control adaptor for outdoor unit PCB DS1 and DS2 so that it matches the unified cool/heat address of outdoor unit main PCB.

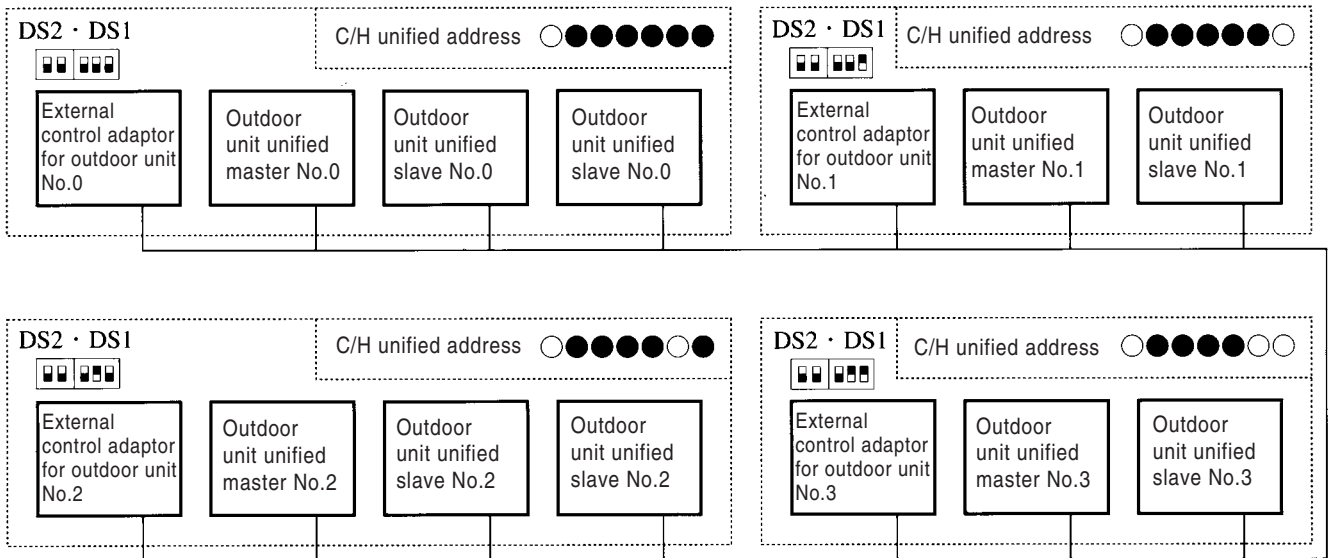

(V2723)

Address setting for ③ and ④ (Set lower 5 digits with binary number.) [No.0 to No.31]

Address No.	Outdoor unit PCB LED Set with setting mode 2		External control adaptor for outdoor unit				
	DS2	DS1	DS2	DS1	DS2	DS1	
No 0	○ ●	● ● ● ● ● ● 0					0
No 1	○ ●	● ● ● ● ○ ● 1					1
No 2	○ ●	● ● ● ○ ● ● 2					2
No 3	○ ●	● ● ● ○ ○ ● 3					3
No 4	○ ●	● ● ○ ● ● ● 4					4
?		?					
No 30	○ ●	● ● ● ● ○ ● 30					30
No 31	○ ●	○ ○ ○ ○ ○ ● 31					31

○ ON ● OFF Upper position (ON) lower position (OFF)
(The shaded part shows knob)

⑤ Set cool/heat at all outdoor unit systems simultaneously for each external control adaptor for outdoor unit by using the centralized remote controller.

- ◆ Install the external control adaptor for outdoor unit (optional) onto the outdoor-outdoor, indoor-outdoor, or indoor-indoor transmission line.
- ◆ Use "setting mode 1" and set all outdoor units to SLAVE.
- ◆ Set the outdoor unit external control adaptor for outdoor unit SS1 to BOTH (factory setting) or C/H and set SS2 to ON.
- ◆ Use "setting mode 2" and set DS1 and DS2 on the external control adaptors for outdoor unit and the unified heat/cool address on the outdoor unit main PCB to the same address. (The factory setting addresses are all "0".)

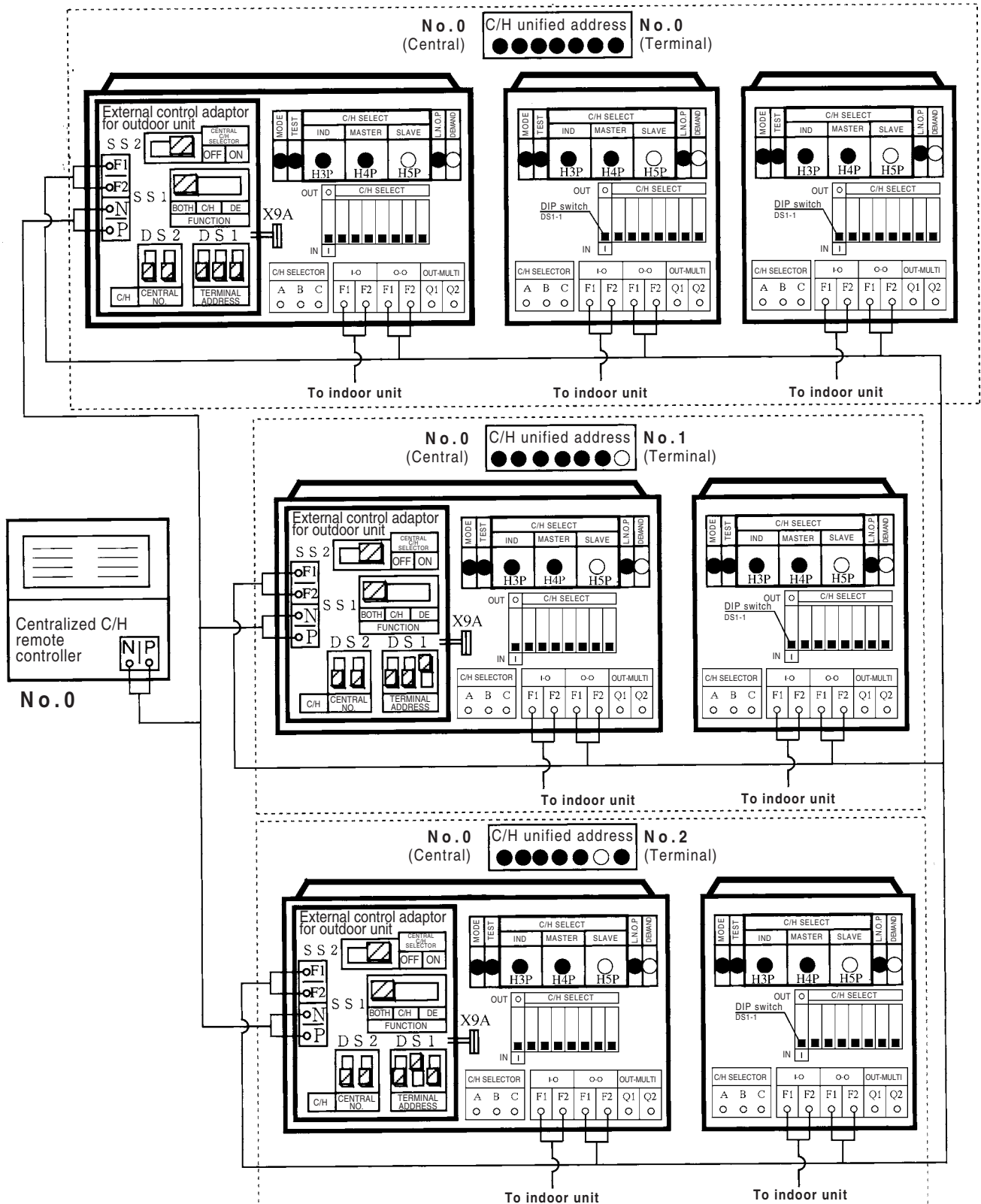

2.1.5 Setting of Low Noise Operation and Demand Operation

Setting of Low Noise Operation

By connecting the external contact input to the low noise input of the outdoor unit external control adaptor for outdoor unit (optional), you can lower operating noise by 2-3 dB.

Setting	Content
Mode 1	Set the outdoor unit fan to Step 6 or lower.
Mode 2	Set the outdoor unit fan to Step 5 or lower.
Mode 3	Set the outdoor unit fan to Step 4 or lower.

A. When the low noise operation is carried out by external contact (with the use of the external control adaptor for outdoor unit)

1. Connect external control adaptor for outdoor unit and short circuit terminal of low noise (Refer to below figure).

If carrying out demand or low-noise input, connect the adaptor's terminals as shown below.

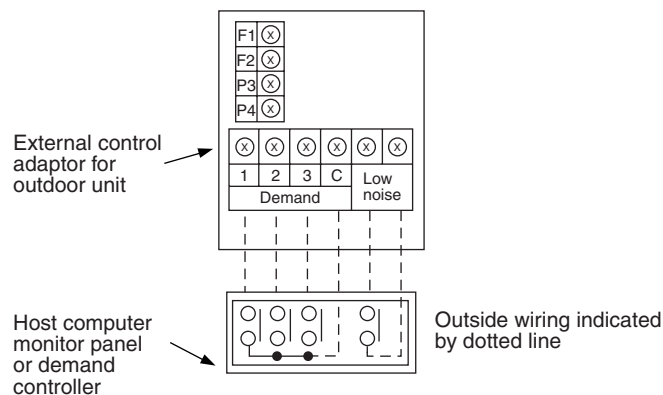

2. While in "Setting mode 2", set the setting condition for set item No. 12 (Setting of external low noise/demand operation) to "YES".
3. If necessary, while in "Setting mode 2", select the setting condition (i.e., "Mode 1", "Mode 2", or "Mode 3") for set item No. 25 (Setting of external low noise level).
4. If necessary, while in "Setting mode 2", set the setting condition for the set item No. 29 (Setting of capacity precedence) to "ON".
(If the condition is set to "ON", when the air-conditioning load reaches a high level, the low noise operation command will be ignored to put the system into normal operation mode.)

B. When the low noise operation is carried out automatically at night (The external control adaptor for outdoor unit is not required)

1. While in "Setting mode 2", select the setting condition (i.e., "Mode 1", "Mode 2", or "Mode 3") for set item No. 22 (Setting of low night noise level).
2. If necessary, while in "Setting mode 2", select the setting condition (i.e., "20:00", "22:00", or "24:00") for set item No. 26 (Setting of start time of low night noise operation).
(Use the start time as a guide since it is estimated according to outdoor temperatures.)
3. If necessary, while in "Setting mode 2", select the setting condition (i.e., "06:00", "07:00", or "08:00") for set item No. 27 (Setting of end time of low night noise operation).
(Use the end time as a guide since it is estimated according to outdoor temperatures.)
4. If necessary, while in "Setting mode 2", set the setting condition for set item No. 29 (Setting of capacity precedence) to "ON".
(If the condition is set to "ON", when the air-conditioning load reaches a high level, the system will be put into normal operation mode even during night-time.)

2.1.6 Setting of Demand Operation

By connecting the external contact input to the demand input of the outdoor unit external control adaptor for outdoor unit (optional), the power consumption of unit operation can be saved suppressing the compressor operating condition.

Setting content			Setting method	
Set item	Condition	Content	External control adaptor	Outdoor unit PCB
Demand 1	Mode 1	The compressor operates at approx. 60% or less of rating.	Short circuit "1" and "C" on the terminal strip (TeS1).	Set item No. 32 to "Demand 1", and item No. 30 to "Level 1".
	Mode 2	The compressor operates at approx. 70% or less of rating.		Set item No. 32 to "Demand 1", and item No. 30 to "Level 2".
	Mode 3	The compressor operates at approx. 80% or less of rating.		Set item No. 32 to "Demand 1", and item No. 30 to "Level 3".
Demand 2	—	The compressor operates at approx. 40% or less of rating.	Short circuit "2" and "C".	Set item No. 32 to "Demand 2".
Demand 3	—	Forced thermostat OFF.	Short circuit "3" and "C".	—

*: However the demand operation does not occur in the following operation modes.

- ① Startup control ② Oil return operation
 ③ Defrosting operation ④ Pump down residual operation

If carrying out demand or low-noise input, connect the adaptor's terminals as shown below.

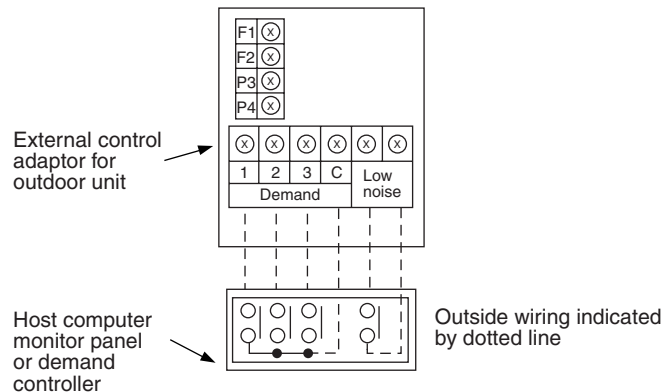

A. When the demand operation is carried out by external contact (with the use of the external control adaptor for outdoor unit).

1. Connect external control adaptor for outdoor unit and short circuit terminals as required (Refer to above figure).
2. While in "Setting mode 2", set the setting condition for set item No. 12 (Setting of external low noise/ demand operation) to "YES".
3. If necessary, while in "Setting mode 2", select the set item No. 30 (Setting of Demand 1 level) and then set the setting condition to targeted mode.

B. When the normal demand operation is carried out. (Use of the external control adaptor for outdoor unit is not required.)

1. While in "Setting mode 2", make setting of the set item No. 32 (Setting of alternate demand) to "ON".
2. While in "Setting mode 2", select the set item No. 30 (Setting of Demand 1 level) and then set the setting condition to targeted mode.

2.1.7 Air Tight Test Procedure

After internal servicing is performed onsite, perform the air tight test. Fully open the electronic expansion valves of the outdoor unit and indoor unit, and turn ON some of the solenoid valves.

[Operation procedure]

- ① With the system stopped, use "Setting mode 2" and set (A) Refrigerant recovery / vacuuming mode (setting item No. 21) to "ON".
All of the indoor unit and outdoor unit electronic expansion valves fully open and some of the solenoid valves turn ON. (H2P blinks to indicate the test operation, and the remote controller displays "TEST OPERATION" and "UNDER CENTRALIZED CONTROL", thus prohibiting operation.)
- ② Close the stop valves on the gas side and liquid side, and perform an air tight test at 4.0 MPa.
- ③ Press the MODE button (BS1) to cancel "Setting mode 2".

<Caution>

Do not turn off the outdoor unit power during the air tight test.

(The solenoid valves will close and the outdoor unit air tight test will not be possible.)

2.1.8 Setting of Refrigerant Recovery Mode

When carrying out the refrigerant recovery onsite, fully open the respective expansion valve of indoor and outdoor units.

All indoor and outdoor unit's operation are prohibited.

[Operation procedure]

- ① In setting mode 2 with units in stop mode, set "Refrigerant recovery / Vacuuming mode" to ON. The respective expansion valve of indoor and outdoor units are fully opened and some of solenoid valves open. (H2P turns to display "TEST OPERATION" (blinks), "TEST OPERATION" and "UNDER CENTRALIZED CONTROL" are displayed on the remote controller, and the all indoor / outdoor unit operation is prohibited.
After setting, do not cancel "Setting Mode 2" until completion of refrigerant recovery operation.
- ② Collect the refrigerant using a refrigerant recovery unit. (See the installation manual attached to the refrigerant recovery unit for more detail.)
- ③ Press Mode button "BS1" once and reset "Setting Mode 2".

2.1.9 Setting of Vacuuming Mode

In order to perform vacuuming operation onsite, fully open the expansion valves of indoor and outdoor units and turn on some solenoid valves.

[Operating procedure]

- ① With Setting Mode 2 while the unit stops, set "Refrigerant recovery / Vacuuming mode" to ON. The expansion valves of indoor and outdoor units fully open and some of solenoid valves open.
(H2P blinks to indicate the test operation, and the remote controller displays "TEST OPERATION" and "UNDER CENTRALIZED CONTROL", thus prohibiting operation.)
After setting, do not cancel "Setting Mode 2" until completion of vacuuming operation.
- ② Use the vacuum pump to perform vacuuming operation.
- ③ Press Mode button "BS1" once and reset "Setting Mode 2".

2.1.10 Emergency Operation

If the compressor cannot operate, this control inhibits any applicable compressor or outdoor unit from operating to perform emergency operation only with the operative compressor or outdoor unit.



Caution

In order to disable the compressor operation due to a failure or else, be sure to do so in emergency operation mode.

NEVER attempt to disconnect power supply wires from magnetic contactors or else. (Doing so will operate compressors in combination that disables oil equalization between the compressors, thus resulting in errors of other normal compressors.)

[Restrictions for Emergency Operation]

- In the case of system with 1 outdoor unit installed, only when thermostats of indoor units having a capacity of 50% or more of the outdoor unit capacity turn ON, the emergency operation is functional. (If the total capacity of indoor units with thermostat ON is small, the outdoor unit cannot operate.)
- If the emergency operation is set while the outdoor unit is in operation, the outdoor unit stops once after pump down residual operation (a maximum of 5 minutes elapsed).

(1) In the Case of 1-Outdoor-Unit System

[Set the system to operation prohibition mode by compressor]

- In order to set an INV compressor to operation prohibition mode, set No. 42 of Setting mode 2 to "EMERGENCY OPERATION".

(Procedure)

- (1) Press and hold the MODE button (BS1) for a period of 5 seconds or more.
- (2) Press the SET button (BS2) 42 times.
- (3) Press the RETURN button (BS3) once.
- (4) Press the SET button (BS2) once.
- (5) Press the RETURN button (BS3) twice.
- (6) Press the MODE button (BS1) once.

- In order to set STD1 and STD2 compressors to operation prohibition mode, set No. 19 of Setting mode 2 to "STD1, 2 OPERATION PROHIBITION".

(Procedure)

- (1) Press and hold the MODE button (BS1) for a period of 5 seconds or more.
- (2) Press the SET button (BS2) 19 times.
- (3) Press the RETURN button (BS3) once.
- (4) Press the SET button (BS2) once.
- (5) Press the RETURN button (BS3) twice.
- (6) Press the MODE button (BS1) once.

- In order to set the STD 2 compressor to operation prohibition mode, set No. 19 of Setting mode 2 to "STD2 OPERATION PROHIBITION".

(Procedure)

- (1) Press and hold the MODE button (BS1) for a period of 5 seconds or more.
- (2) Press the SET button (BS2) 19 times.
- (3) Press the RETURN button (BS3) once.
- (4) Press the SET button (BS2) twice.
- (5) Press the RETURN button (BS3) twice.
- (6) Press the MODE button (BS1) once.

- For RQYQ16PY1, if the INV compressor is set to operation prohibition mode, only a single STD compressor will operate for the convenience of oil equalization.
- For RQYQ16PY1, only the STD1 compressor cannot be put into operation prohibition mode for the convenience of oil equalization.
- For the system with a single outdoor unit, automatic backup operation is not functional.

LED display (○: ON ●: OFF ◐: Blink)

H1P — — — H7P



(Factory setting)

LED display (○: ON ●: OFF ◐: Blink)

H1P — — — H7P



(Factory setting)

LED display (○: ON ●: OFF ◐: Blink)

H1P — — — H7P



(Factory setting)

(2) In the Case of Multi-Outdoor-Unit System**[Automatic backup operation]**

With multi-outdoor-unit system, if a certain outdoor unit system errors (i.e., the system stops and indoor unit remote controller displays the error), by resetting the system with the indoor unit remote controller, the applicable outdoor unit is inhibited from operating for 8 hours, thus making it possible to perform backup operation automatically.

However, in the event any of the following errors occurs, automatic backup operation can be performed.

Errors under which automatic backup operation can be performed:

- E3, E4, E5, E7
- F3
- H7, H9
- J2, J3, J5, J6, J7, J9, JA, JC
- L1, L4, L5, L8, L9, LC
- U2, UJ



Note : In order to forcibly clear the automatic backup operation, reset the power supply with the outdoor unit in the stopped state.

[Emergency operation with settings in service mode]

*"Inhibition of operation" is set with each outdoor unit.

Make the following settings with the master unit. (Setting with the slave unit becomes disabled.)

*Discriminate the operating status of the master unit / slave units through the following LED display.

LED display (○: ON ●: OFF ◐: Blink)
H1P — — — H7P H8P

Master: ●●○●●●●● ○

Slave : ●●●●●●●● ◐ (Factory setting)

- In order to set the master unit to operation prohibition mode, set No. 38 of Setting mode 2 to "MASTER OPERATION PROHIBITION".

(Procedure)

- (1) Press and hold the MODE button (BS1) for a period of 5 seconds or more.
- (2) Press the SET button (BS2) 38 times.
- (3) Press the RETURN button (BS3) once.
- (4) Press the SET button (BS2) once.
- (5) Press the RETURN button (BS3) twice.
- (6) Press the MODE button (BS1) once.

LED display (○: ON ●: OFF ◐: Blink)
H1P — — — H7P

○●●●●●●●

○○●●●○

○●●●●●◐

○●●●●●◐

○●●●●●●●

●●○●●●●●

(Factory setting)

- In order to set the slave unit to operation prohibition mode, set No. 39 of Setting mode 2 to "SLAVE OPERATION PROHIBITION".

(Procedure)

- (1) Press and hold the MODE button (BS1) for a period of 5 seconds or more.
- (2) Press the SET button (BS2) 39 times.
- (3) Press the RETURN button (BS3) once.
- (4) Press the SET button (BS2) once.
- (5) Press the RETURN button (BS3) twice.
- (6) Press the MODE button (BS1) once.

LED display (○: ON ●: OFF ◐: Blink)
H1P — — — H7P

○●●●●●●●

○○●●○

○●●●●●◐

○●●●●●◐

○●●●●●●●

●●○●●●●●

(Factory setting)

*

- In the case of multi-outdoor-unit system, "Inhibition of operation" is not set with each compressor individually.
- In the case of multi-outdoor-unit system, when the above "Inhibition of operation" is set, outdoor unit rotation is not functional.

Part 6

Service Diagnosis

1. Symptom-based Troubleshooting	92
2. Troubleshooting by Remote Controller	95
2.1 Procedure of Self-diagnosis by Remote Controller	95
2.2 PCB Abnormality	104
2.3 Actuation of High Pressure Switch or Pressure Switch	105
2.4 Actuation of High Pressure Switch (S1PH) or Pressure Switch (S2P)	106
2.5 Actuation of Low Pressure Sensor	108
2.6 Inverter Compressor Motor Lock	110
2.7 STD Compressor Motor Overcurrent/Lock	112
2.8 Outdoor Unit Fan Motor Abnormality	113
2.9 Electronic Expansion Valve Coil Abnormality (Y1E~Y3E)	116
2.10 Abnormal Discharge Pipe Temperature	118
2.11 Humidity Alarm	120
2.12 Refrigerant Overcharged	122
2.13 High Pressure Switch System Abnormality	123
2.14 Abnormal Outdoor Fan Motor Signal	124
2.15 Thermistor System Abnormality	126
2.16 High Pressure Sensor Abnormality	127
2.17 Current Sensor Abnormality	129
2.18 High Pressure Sensor Abnormality	130
2.19 Low Pressure Sensor Abnormality	132
2.20 Inverter PCB Abnormality	134
2.21 Inverter Radiation Fin Temperature Rise	136
2.22 Momentary Overcurrent of Inverter Compressor	137
2.23 Overcurrent Abnormal of Inverter Compressor	139
2.24 Inverter Compressor Starting Abnormality	141
2.25 Transmission System Error (between Inverter and Main PCB)	143
2.26 Inverter Over-Ripple Protection	145
2.27 Inverter Radiation Fin Temperature Abnormality	147
2.28 Field Setting Abnormality after Replacing Main PCB or Combination Error of PCB	148
2.29 Refrigerant Shortage	149
2.30 Reverse Phase, Open Phase	151
2.31 Power Supply Insufficient or Instantaneous Failure	152
2.32 Check Operation is not Executed	155
2.33 Transmission Error (between Indoor and Outdoor Units)	156
2.34 Transmission Error (between Remote Controller and Indoor Unit)	159
2.35 Transmission Error (Across Outdoor Units)	160
2.36 Transmission Error (between Main and Sub Remote Controllers)	166
2.37 Transmission Error (between Indoor and Outdoor Units in the Same System)	167
2.38 Improper Combination of Indoor and Outdoor Units, Indoor Units and Remote Controller	168
2.39 Address Duplication of Centralized Controller	172

2.40 Transmission Error (between Centralized Controller and Indoor Unit)	173
2.41 System is not Set yet.....	176
2.42 System Error, Refrigerant System Address Undefined	177
2.43 Check	179

1. Symptom-based Troubleshooting

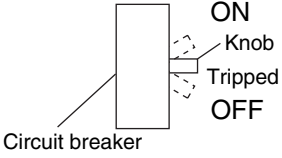
	Symptom	Supposed Cause	Countermeasure	
1	The system does not start operation at all.	Blowout of fuse(s)	Turn OFF the power supply and then replace the fuse(s).	
		Cutout of breaker(s)	<ul style="list-style-type: none"> If the knob of any breaker is in its OFF position, turn ON the power supply. If the knob of any circuit breaker is in its tripped position, do not turn ON the power supply. 	
		Power failure	After the power failure is reset, restart the system.	
2	The system starts operation but makes an immediate stop.	Blocked air inlet or outlet of indoor or outdoor unit	Remove obstacle(s).	
		Clogged air filter(s)	Clean the air filter(s).	
3	The system does not cool or heat air well.	Blocked air inlet or outlet of indoor or outdoor unit	Remove obstacle(s).	
		Clogged air filter(s)	Clean the air filter(s).	
		Enclosed outdoor unit(s)	Remove the enclosure.	
		Improper set temperature	Set the temperature to a proper degree.	
		Airflow rate set to "LOW"	Set it to a proper airflow rate.	
		Improper direction of air diffusion	Set it to a proper direction.	
		Open window(s) or door(s)	Shut it tightly.	
		[In cooling] Direct sunlight received	Hang curtains or shades on windows.	
		[In cooling] Too many persons staying in a room	The model must be selected to match the air conditioning load.	
[In cooling] Too many heat sources (e.g. OA equipment) located in a room				
4	The system does not operate.	The system stops and immediately restarts operation.	Normal operation. The system will automatically start operation after a lapse of five minutes.	
		Pressing the TEMP ADJUST button immediately resets the system.		
		The remote controller displays "UNDER CENTRALIZED CONTROL", which blinks for a period of several seconds when the OPERATION button is depressed.	The system is controlled with centralized controller. Blinking display indicates that the system cannot be operated using the remote controller.	Operate the system using the COOL/HEAT centralized remote controller.
		The system stops immediately after turning ON the power supply.	The system is in preparation mode of micro-computer operation.	Wait for a period of approximately one minute.
5	The system makes intermittent stops.	The remote controller displays error codes "U4" and "U5", and the system stops but restarts after a lapse of several minutes.	The system stops due to an interruption in communication between units caused by electrical noises coming from equipment other than air conditioners.	Remove causes of electrical noises. If these causes are removed, the system will automatically restart operation.
6	COOL-HEAT selection is disabled.	The remote controller displays "UNDER CENTRALIZED CONTROL".	This remote controller has no option to select cooling operation.	Use a remote controller with option to select cooling operation.
		The remote controller displays "UNDER CENTRALIZED CONTROL", and the COOL-HEAT selection remote controller is provided.	COOL-HEAT selection is made using the COOL-HEAT selection remote controller.	Use the COOL-HEAT selection remote controller to select cool or heat.

	Symptom	Supposed Cause	Countermeasure
7	The system conducts fan operation but not cooling or heating operation.	This symptom occurs immediately after turning ON the power supply.	The system is in preparation mode of operation. Wait for a period of approximately 10 minutes.
		"UNDER CENTRALIZED CONTROL" is displayed on the remote controller and the cooling/heating operation stops. The operation switches to the air supply operation.	Even though, the cooling or heating operation is set, the air supply operation continues during thermal storage operation. "UNDER CENTRALIZED CONTROL" is displayed on the remote controller. Normal operation.
8	The airflow rate is not reproduced according to the setting.	Even pressing the AIRFLOW RATE SET button makes no changes in the airflow rate.	In heating operation, when the room temperature reaches the set degree, the outdoor unit will stop while the indoor unit is brought to fan LL operation so that no one gets cold air. Furthermore, if fan operation mode is selected when other indoor unit is in heating operation, the system will be brought to fan LL operation. Normal operation.
9	The airflow direction is not reproduced according to the setting.	The airflow direction is not corresponding to that displayed on the remote controller. The flap does not swing.	Automatic control Normal operation.
10	A white mist comes out from the system.	<Indoor unit> In cooling operation, the ambient humidity is high. (This indoor unit is installed in a place with much oil or dust.)	Uneven temperature distribution due to heavy stain of the inside of the indoor unit Clean the inside of the indoor unit.
		<Indoor unit> Immediately after cooling operation stopping, the ambient temperature and humidity are low.	Hot gas (refrigerant) flown in the indoor unit results to be vapor from the unit. Normal operation.
		<Indoor and outdoor units> After the completion of defrosting operation, the system is switched to heating operation.	Defrosted moisture turns to be vapor and comes out from the units. Normal operation.

	Symptom	Supposed Cause	Countermeasure	
11	The system produces sounds.	<Indoor unit> Immediately after turning ON the power supply, indoor unit produces "ringing" sounds.	These are operating sounds of the electronic expansion valve of the indoor unit.	Normal operation. This sound becomes low after a lapse of approximately one minute.
		<Indoor and outdoor units> "Hissing" sounds are continuously produced while in cooling or defrosting operation.	These sounds are produced from gas (refrigerant) flowing respectively through the indoor and outdoor units.	Normal operation.
		<Indoor and outdoor units> "Hissing" sounds are produced immediately after the startup or stop of the system, or the startup or stop of defrosting operation.	These sounds are produced when the gas (refrigerant) stops or changes flowing.	Normal operation.
		<Indoor unit> Faint sounds are continuously produced while in cooling operation or after stopping the operation.	These sounds are produced from the drain discharge device in operation.	Normal operation.
		<Indoor unit> "Creaking" sounds are produced while in heating operation or after stopping the operation.	These sounds are produced from resin parts expanding and contracting with temperature changes.	Normal operation.
		<Indoor unit> Sounds like "trickling" or the like are produced from indoor units in the stopped state.	On VRV systems, these sounds are produced when other indoor units in operation. The reason is that the system runs in order to prevent oil or refrigerant from dwelling.	Normal operation.
		<Outdoor unit> Pitch of operating sounds changes.	The reason is that the compressor changes the operating frequency.	Normal operation.
12	Dust comes out from the system.	Dust comes out from the system when it restarts after the stop for an extended period of time.	Dust, which has deposited on the inside of indoor unit, is blown out from the system.	Normal operation.
13	Odors come out from the system.	In operation	Odors of room, cigarettes or else adsorbed to the inside of indoor unit are blown out.	The inside of the indoor unit should be cleaned.
14	Outdoor unit fan does not rotate.	In operation	The reason is that fan revolutions are controlled to put the operation to the optimum state.	Normal operation.
15	LCD display "E8" appears on the remote controller.	Immediately after turning ON the power supply	The reason is that the system is checking to be sure the remote controller is normal.	Normal operation. This code is displayed for a period of approximately one minute at maximum.
16	The outdoor unit compressor or the outdoor unit fan does not stop.	After stopping operation	It stops in order to prevent oil or refrigerant from dwelling.	Normal operation. It stops after a lapse of approximately 5 to 10 minutes.
17	The outdoor gets hot.	While stopping operation	The reason is that the compressor is warmed up to provide smooth startup of the system.	Normal operation.
18	Hot air comes out from the system even though it stops.	Hot air is felt while the system stops.	On VRV systems, small quantity of refrigerant is fed to indoor units in the stopped state when other indoor units are in operation.	Normal operation.
19	The system does not cool air well.	The system is in dry operation.	The reason is that the dry operation serves not to reduce the room temperature where possible.	Change the system to cooling operation.

2. Troubleshooting by Remote Controller

2.1 Procedure of Self-diagnosis by Remote Controller

2.1.1 Wired Remote Controller — BRC1D528

If operation stops due to error, the remote controller's operation LED blinks, and error code is displayed. (Even if stop operation is carried out, error contents are displayed when the inspection mode is entered.) The error code enables you to tell what kind of error caused operation to stop. Refer to P.99 for error code and error contents.

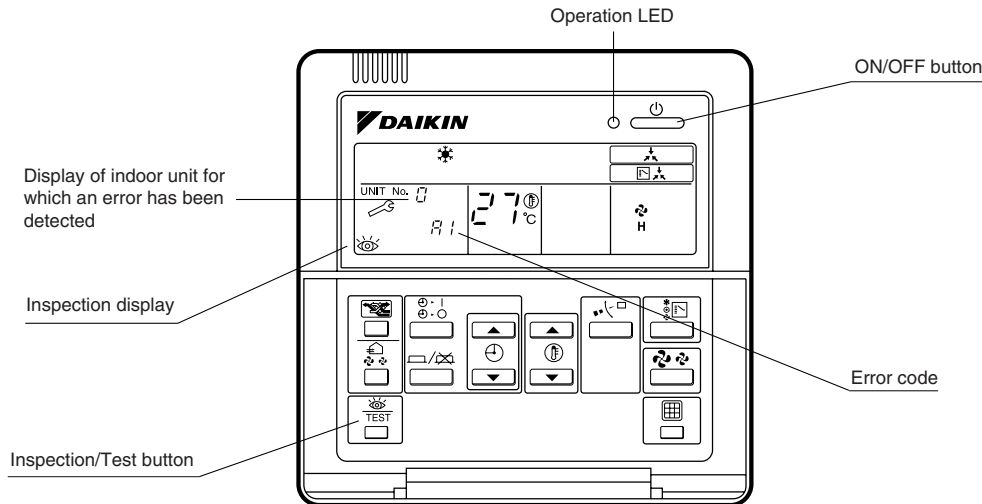

i Note:

1. Pressing the INSPECTION/TEST button will blink the check indication.
2. While in service mode, holding down the ON/OFF button for a period of 5 seconds or more will clear the error history indication shown above. In this case, on the codes display, the error code will blink twice and then change to "00" (=Normal), the Unit No. will change to "0", and the operation mode will automatically switch from service mode to normal mode (displaying the set temperature).

2.1.2 Wired Remote Controller — BRC1E51A7

The following will be displayed on the screen when an error (or a warning) occurs during operation. Check the error code and take the corrective action specified for the particular model.

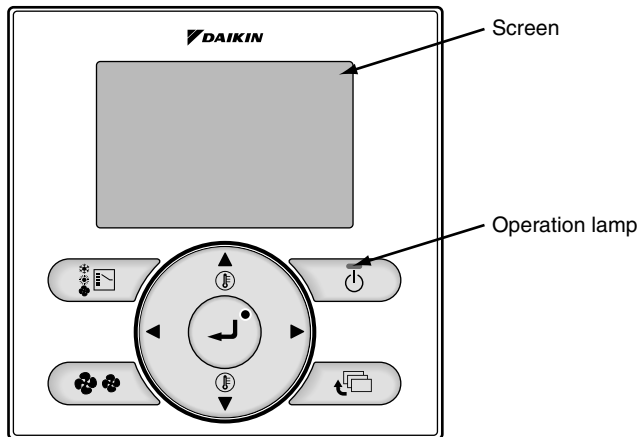

(1)Checking an error or warning

	Operation Status	Display	
Abnormal shutdown	The system stops operating.	The operation lamp (green) starts to blink. The message "Error: Press Menu button" will appear and blink at the bottom of the screen.	
Warning	The system continues its operation.	The operation lamp (green) remains on. The message "Warning: Press Menu button" will appear and blink at the bottom of the screen.	

(2)Taking corrective action

- Press the Menu/Enter button to check the error code.





- Take the corrective action specific to the model.

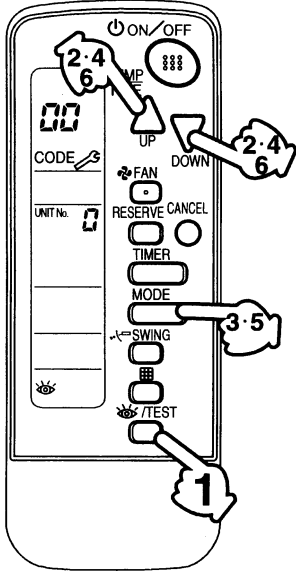

2.1.3 Wireless Remote Controller

If unit stops due to an error, the operation indicating LED on the signal receiving part of indoor unit flashes. The error code can be determined by following the procedure described below. (The error code is displayed when an operation error has occurred. In normal condition, the error code of the last problem is displayed.)

1	Press the INSPECTION/TEST button to select "inspection". The equipment enters the inspection mode. The "Unit" indication is displayed and the Unit No. display shows flashing "0" indication.	
2	Set the Unit No. Press the UP or DOWN button and change the Unit No. display until the buzzer (*1) is generated from the indoor unit. *1 Number of beeps 3 short beeps : Conduct all of the following operations. 1 short beep : Conduct steps 3 and 4. Continue the operation in step 4 until a buzzer remains ON. The continuous buzzer indicates that the error code is confirmed. Continuous beep : No abnormality.	
3	Press the MODE selector button. The left "0" (upper digit) indication of the error code flashes.	
4	Error code upper digit diagnosis Press the UP or DOWN button and change the error code upper digit until the error code matching buzzer (*2) is generated. ■ The upper digit of the code changes as shown below when the UP and DOWN buttons are pressed. <div style="text-align: center;">  <p>⇒ "UP" button ⇐ "DOWN" button</p> </div> *2 Number of beeps Continuous beep : Both upper and lower digits matched. (Error code confirmed) 2 short beeps : Upper digit matched. 1 short beep : Lower digit matched.	
5	Press the MODE selector button. The right "0" (lower digit) indication of the error code flashes.	
6	Error code lower digit diagnosis Press the UP or DOWN button and change the error code lower digit until the continuous error code matching buzzer (*2) is generated. ■ The lower digit of the code changes as shown below when the UP and DOWN buttons are pressed. <div style="text-align: center;">  <p>⇒ "UP" button ⇐ "DOWN" button</p> </div>	

Normal status
 Enters inspection mode from normal status when the INSPECTION/ TEST button is pressed.

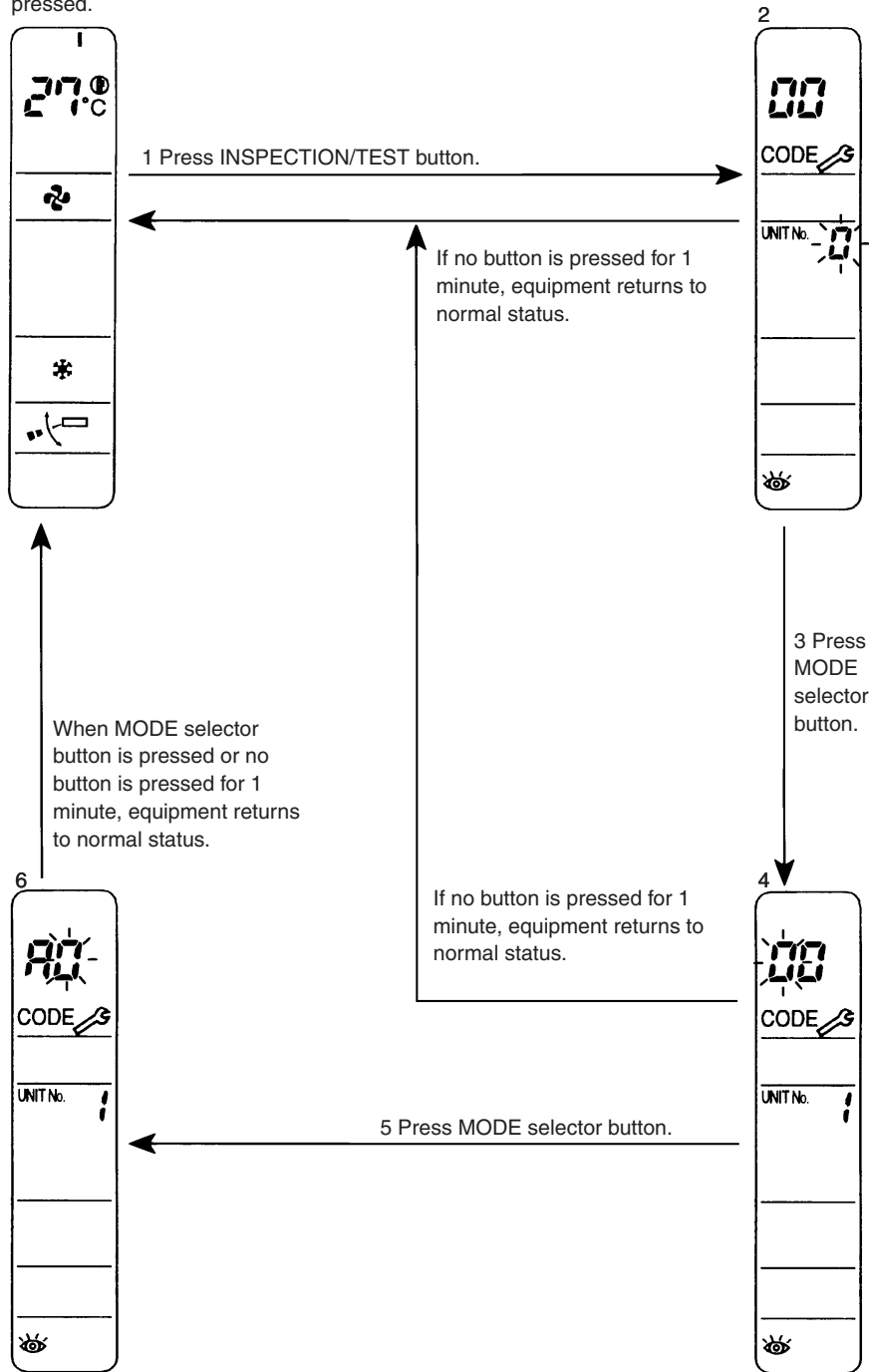

○: ON ●: OFF ◐: Blink

	Error code	Operation lamp	Error contents	Page Referred
Outdoor Unit	E1	◐	PCB abnormality	104
	E2	◐	Actuation of high pressure switch or pressure switch	105
	E3	◐	Actuation of high pressure switch or pressure switch	106
	E4	◐	Actuation of low pressure sensor	108
	E5	◐	Inverter compressor motor lock	110
	E6	◐	STD compressor motor overcurrent/Lock	112
	E7	◐	Outdoor unit fan motor abnormality	113
	E9	◐	Electronic expansion valve coil abnormality (Y1E ~ Y3E)	116
	F3	◐	Abnormal discharge pipe temperature	118
	F4	◐	Humidity alarm	120
	F6	◐	Refrigerant overcharged	122
	H3	◐	High pressure switch system abnormality	123
	H7	◐	Abnormal outdoor fan motor signal	124
	H9	◐	Abnormal outdoor air thermistor	126
	J1	◐	High pressure sensor abnormality	127
	J2	◐	Currents sensor abnormality	129
	J3	◐	Abnormal discharge pipe thermistor	126
	J5	◐	Abnormal suction pipe thermistor	126
	J6	◐	Abnormal heat exchanger deicer thermistor	126
	J7	◐	Abnormal liquid pipe thermistor	126
	J8	◐	Abnormal receiver gas vent outlet thermistor	126
	J9	◐	Abnormal subcooling heat exchanger outlet thermistor	126
	JA	◐	High pressure sensor abnormality	130
	JC	◐	Low pressure sensor abnormality	132
	L1	◐	Inverter PCB abnormality	134
	L4	◐	Inverter radiation fin temperature rise	136
	L5	◐	Momentary overcurrent of inverter compressor	137
	L8	◐	Overcurrent abnormal of inverter compressor	139
	L9	◐	Inverter compressor starting abnormality	141
	LA	◐	Power unit abnormality	—
	LC	◐	Transmission system error (between inverter and main PCB)	143
	P1	◐	Inverter over-ripple protection	145
	P4	◐	Inverter radiation fin temperature abnormality	147
PJ	◐	Field setting abnormality after replacing main PCB or combination error of PCB	148	
System	U0	○	Refrigerant shortage	149
	U1	◐	Reverse phase, open phase	151
	U2	◐	Power supply insufficient or instantaneous failure	152
	U3	◐	Check operation is not executed	155
	U4	◐	Transmission error (between indoor and outdoor units)	156
	U5	◐	Transmission error (between remote controller and indoor unit)	159
	U7	◐	Transmission error (Across outdoor units)	160
	U8	◐	Transmission error (between main and sub remote controllers)	166
	U9	◐	Transmission error (between indoor and outdoor units in the same system)	167
	UA	◐	Improper combination of indoor and outdoor units, indoor units and remote controller	168
	UC	○	Address duplication of centralized controller	172
	UE	◐	Transmission error (between centralized controller and indoor unit)	173
	UF	◐	System is not set yet	176
UH	◐	System error, refrigerant system address undefined	177	

Error code indication by outdoor unit PCB

<Monitor mode>

To enter the monitor mode, press the **MODE (BS1)** button when in "Setting mode 1".

* Refer to P. 77 for Monitor mode.

<Selection of setting item>

Press the **SET (BS2)** button and set the LED display to a setting item.

* Refer to P. 77 for Monitor mode.

<Confirmation of error 1>

Press the **RETURN (BS3)** button once to display "First digit" of error code.

<Confirmation of error 2>

Press the **SET (BS2)** button once to display "Second digit" of error code.

<Confirmation of error 3>

Press the **SET (BS2)** button once to display "error location".

<Confirmation of error 4>

Press the **SET (BS2)** button once to display "master or slave 1 or slave 2 or slave 3" and "error location".

Press the **RETURN (BS3)** button and switches to the initial status of "Monitor mode".

* Press the **MODE (BS1)** button and returns to "Setting mode 1".

Detail description on next page.

Error		Error code
Description of error	Description of error (PGF)	Remote controller
PCB abnormality	Defective PCB	E1
Abnormal discharge pressure or field piping pressure	HPS or PS activated	E2
High pressure abnormality	High pressure switch activated	E3
Actuation of low pressure sensor	Defective Pe	E4
Inverter compressor motor lock	INV compressor lock detected	E5
STD compressor motor overcurrent/ Lock	STD 1	E6
	STD 2	
Outdoor unit fan motor abnormality	Defective fan motor 1	E7
	Defective fan motor 2	
Electronic expansion valve coil abnormality (Y1E-Y3E)	Y1E (Main)	E9
	Y2E (Refrigerant charging)	
	Y3E (Subcool heat exchanger)	
Abnormal discharge pipe temperature	Defective Td	F3
Refrigerant overcharge	Abnormal heat exchanger temperature	F6
High pressure switch system abnormality		H3
Abnormal outdoor fan motor signal	Fan motor 1 positioning signal	H7
	Fan motor 2 positioning signal	
Thermistor abnormality	Thermistor (Outdoor air)	H9
High pressure sensor abnormality	Defective high pressure sensor	J1
Current sensor abnormality	STD 1	J2
	STD 2	
Thermistor abnormality (discharge pipe)	For INV. compressor	J3
	For STD 1 compressor	
	For STD 2 compressor	
Thermistor abnormality (suction pipe)	TsA sensor malfunction (short-circuited)	J5
Thermistor abnormality (heat exchanger deicer)	Tb sensor malfunction	J6
Thermistor abnormality (liquid pipe)	Tsc sensor malfunction	J7
	TL sensor malfunction	
Thermistor abnormality (receiver liquid level, refrigerant regulator liquid pipe, Receiver gas vent outlet)	Tf sensor malfunction	J8
Thermistor abnormality (subcooling heat exchanger outlet)	Tsh sensor malfunction	J9
High pressure sensor abnormality	Defective high pressure sensor	JA
Low pressure sensor abnormality	Defective low pressure sensor	JC

○ : ON
 ● : Blink
 ● : OFF

○: ON ●: OFF ◐: Blink

Error code	Confirmation of error 1 (Check 1)							Confirmation of error 2 (Check 2)							Confirmation of error 3 (Check 3)							Confirmation of error 4 (Check 4)							
	H1P	H2P	H3P	H4P	H5P	H6P	H7P	H1P	H2P	H3P	H4P	H5P	H6P	H7P	H1P	H2P	H3P	H4P	H5P	H6P	H7P	H1P	H2P	H3P	H4P	H5P	H6P	H7P	
E1	◐	◐	●	●	●	◐	◐	◐	●	○	●	●	●	◐	◐	○	●	●	●	●	●	◐	○	○	○	●	●	*1	
E2								◐	●	○	●	●	●	◐	◐	○	●	●	●	●	●	◐	○	○	○	●	●		
E3								◐	●	○	●	●	●	◐	◐	○	●	●	●	●	●	◐	○	○	○	●	●		
E4								◐	●	○	●	●	●	◐	◐	○	●	●	●	●	●	◐	○	○	○	●	●		
E5								◐	●	○	●	●	●	◐	◐	○	●	●	●	●	●	◐	○	○	○	●	●		
E6								◐	●	○	●	●	●	◐	◐	○	●	●	●	●	●	◐	○	○	○	●	●		
E7								◐	●	○	●	●	●	◐	◐	○	●	●	●	●	●	◐	○	○	○	●	●		
								◐	●	○	●	●	●	◐	◐	○	●	●	●	●	●	◐	○	○	○	●	●		
								◐	●	○	●	●	●	◐	◐	○	●	●	●	●	●	◐	○	○	○	●	●		
								◐	●	○	●	●	●	◐	◐	○	●	●	●	●	●	◐	○	○	○	●	●		
E9							◐	●	○	●	●	●	◐	◐	○	●	●	●	●	●	◐	○	○	○	●	●			
F3	◐	◐	●	●	◐	●	◐	◐	●	○	●	●	●	◐	◐	○	●	●	●	●	●	◐	○	○	○	●	●		
F6								◐	●	○	●	●	●	◐	◐	○	●	●	●	●	●	◐	○	○	○	●	●	◐	◐
H3	◐	◐	●	●	◐	●	●																				*1		
H7								◐	●	○	●	●	●	◐	◐	○	●	●	●	●	●	◐	○	○	○	●		●	
H9								◐	●	○	●	●	●	◐	◐	○	●	●	●	●	●	◐	○	○	○	●		●	
								◐	●	○	●	●	●	◐	◐	○	●	●	●	●	●	◐	○	○	○	●		●	
J1	◐	◐	●	●	◐	●	◐																						
J2								◐	●	○	●	●	●	◐	◐	○	●	●	●	●	●	◐	○	○	○	●		●	
J3								◐	●	○	●	●	●	◐	◐	○	●	●	●	●	●	◐	○	○	○	●		●	
								◐	●	○	●	●	●	◐	◐	○	●	●	●	●	●	◐	○	○	○	●		●	
J5								◐	●	○	●	●	●	◐	◐	○	●	●	●	●	●	◐	○	○	○	●		●	
J6								◐	●	○	●	●	●	◐	◐	○	●	●	●	●	●	◐	○	○	○	●	●		
J7								◐	●	○	●	●	●	◐	◐	○	●	●	●	●	●	◐	○	○	○	●	●		
J8								◐	●	○	●	●	●	◐	◐	○	●	●	●	●	●	◐	○	○	○	●	●		
J9								◐	●	○	●	●	●	◐	◐	○	●	●	●	●	●	◐	○	○	○	●	●		
JA								◐	●	○	●	●	●	◐	◐	○	●	●	●	●	●	◐	○	○	○	●	●		
JC								◐	●	○	●	●	●	◐	◐	○	●	●	●	●	●	◐	○	○	○	●	●		

Display of contents of error (first digit)

Display of contents of error (second digit)

Display 1 of error in detail

Display 2 of error in detail

*1: System error

<table border="1"> <tr><td>●</td><td>●</td></tr> <tr><td>●</td><td>◐</td></tr> <tr><td>◐</td><td>●</td></tr> <tr><td>◐</td><td>◐</td></tr> </table>	●	●	●	◐	◐	●	◐	◐	→ Individual system	<table border="1"> <tr><td>Master</td></tr> <tr><td>Slave 1</td></tr> <tr><td>Slave 2</td></tr> <tr><td>System</td></tr> </table>	Master	Slave 1	Slave 2	System
●	●													
●	◐													
◐	●													
◐	◐													
Master														
Slave 1														
Slave 2														
System														
→	Right-hand system													
→	Left-hand system													
→	—													
→	All systems													

<Monitor mode>

To enter the monitor mode, press the **MODE (BS1)** button when in "Setting mode 1".

* Refer to P. 77 for Monitor mode.

<Selection of setting item>

Press the **SET (BS2)** button and set the LED display to a setting item.

* Refer to P. 77 for Monitor mode.

<Confirmation of error 1>

Press the **RETURN (BS3)** button once to display "First digit" of error code.

<Confirmation of error 2>

Press the **SET (BS2)** button once to display "Second digit" of error code.

<Confirmation of error 3>

Press the **SET (BS2)** button once to display "error location".

<Confirmation of error 4>

Press the **SET (BS2)** button once to display "master or slave 1 or slave 2 or slave 3" and "error location".

Press the **RETURN (BS3)** button and switches to the initial status of "Monitor mode".

* Press the **MODE (BS1)** button and returns to "Setting mode 1".

Detail description on next page.

Error		Error code
Description of error	Description of error (PGF)	Remote controller
Inverter PCB abnormality	Defective IPM	L1
	Current sensor error confirmation 1	
	Current sensor error confirmation 2	
	IGBT error	
Inverter radiation fin temperature rise	Overheat of INV. radiation fin temperature	L4
Momentary overcurrent of INV. compressor		L5
Overcurrent abnormal of INV. compressor	Electric thermal and others	L8
INV. compressor starting abnormality	Stall prevention	L9
Transmission system abnormality (between INV. and main PCB)	INV. transmission data abnormality	LC
	INV. transmission abnormality	
Inverter over-ripple protection	Unbalanced INV. power supply voltage	P1
INV. radiation fin thermistor and related abnormality	INV. fin thermistor abnormality	P4
Field setting abnormality after replacing main PCB or combination error of PCB	Defective combination of INV.	PJ
Refrigerant shortage		U0
Reverse phase, open phase	Reversed phase	U1
	Reversed phase (ON)	
Power supply insufficient or instantaneous failure	Insufficient INV. voltage	U2
	INV. open phase (single phase)	
	Abnormal charge of capacitor of INV. main circuit	
Check operation is not completed.	Test operation not carried out yet	U3
Transmission error (between indoor and outdoor units)	IN-OUT transmission error	U4
	System error	
Transmission error (between remote controller and indoor unit)		U5
Transmission error (Across outdoor units)	Error caused when mounting the external control adaptor for outdoor unit	U7
	Alarm given when mounting the external control adaptor for outdoor unit	
	Error caused between the master and the slave 1	
	Error caused between the master and the slave 2	
	Defective address setting of slaves 1 and 2	
Improper combination of indoor and outdoor units, indoor units and remote controller	Excess indoor units connected	UA
	Connection of erroneous models of indoor unit	
	Combination error of outdoor units	
Transmission error (between centralized controller and indoor unit)		UE
System is not set yet	Unmatched wiring/piping	UF
System, refrigerant system address undefined	Wrong wiring (auto address error)	UH

○ : ON
 ● : Blink
 ● : OFF

○: ON ●: OFF ◐: Blink

Error code	Confirmation of error 1 (Check 1)							Confirmation of error 2 (Check 2)							Confirmation of error 3 (Check 3)							Confirmation of error 4 (Check 4)						
	H1P	H2P	H3P	H4P	H5P	H6P	H7P	H1P	H2P	H3P	H4P	H5P	H6P	H7P	H1P	H2P	H3P	H4P	H5P	H6P	H7P	H1P	H2P	H3P	H4P	H5P	H6P	H7P
L1	◐	◐	●	●	◐	◐	◐	◐	●	◐	●	●	●	◐	◐	◐	●	●	●	●	●	◐	◐	◐	●	●	*1	
L4								◐	●	◐	●	◐	●	◐	◐	◐	●	●	●	●	●	◐	◐	◐	●	●		
L5								◐	●	◐	●	◐	●	◐	◐	◐	●	●	●	●	●	◐	◐	◐	●	●		
L8								◐	●	◐	●	◐	●	◐	◐	◐	●	●	●	●	●	◐	◐	◐	●	●		
L9								◐	●	◐	●	◐	●	◐	◐	◐	●	●	●	●	●	◐	◐	◐	●	●		
LC								◐	●	◐	●	◐	●	◐	◐	◐	●	●	●	●	●	◐	◐	◐	●	●		
P1	◐	◐	●	◐	●	●	●	◐	●	◐	●	●	●	◐	◐	◐	●	●	●	●	●	◐	◐	◐	●	●		
P4								◐	●	◐	●	◐	●	◐	◐	◐	●	●	●	●	●	◐	◐	◐	●	●		
PJ								◐	●	◐	●	◐	●	◐	◐	◐	●	●	●	●	●	◐	◐	◐	●	●		
U0	◐	◐	●	◐	●	●	●	◐	●	◐	●	●	●	◐	◐	◐	●	●	●	●	●	◐	◐	◐	●	●		◐
U1								◐	●	◐	●	◐	●	◐	◐	◐	●	●	●	●	●	◐	◐	◐	●	●	◐	◐
U2								◐	●	◐	●	◐	●	◐	◐	◐	●	●	●	●	●	◐	◐	◐	●	●	◐	◐
U3								◐	●	◐	●	◐	●	◐	◐	◐	●	●	●	●	●	◐	◐	◐	●	●	◐	◐
U4								◐	●	◐	●	◐	●	◐	◐	◐	●	●	●	●	●	◐	◐	◐	●	●	◐	◐
U5																												
U7								◐	●	◐	●	◐	●	◐	◐	◐	●	●	●	●	●	◐	◐	◐	●	●	◐	◐
UA								◐	●	◐	●	◐	●	◐	◐	◐	●	●	●	●	●	◐	◐	◐	●	●	◐	◐
UE																												
UF								◐	●	◐	●	◐	●	◐	◐	◐	●	●	●	●	●	◐	◐	◐	●	●	◐	◐
UH								◐	●	◐	●	◐	●	◐	◐	◐	●	●	●	●	●	◐	◐	◐	●	●	◐	◐

Display of contents of error (first digit)

Display of contents of error (second digit)

Display 1 of error in detail

Display 2 of error in detail

*1: System error

<table border="1" style="display: inline-table;"> <tr><td>●</td><td>●</td></tr> <tr><td>●</td><td>◐</td></tr> <tr><td>◐</td><td>●</td></tr> <tr><td>◐</td><td>◐</td></tr> </table>	●	●	●	◐	◐	●	◐	◐	→ Individual system	<table border="1" style="display: inline-table;"> <tr><td>Master</td></tr> <tr><td>Slave 1</td></tr> <tr><td>Slave 2</td></tr> <tr><td>System</td></tr> </table>	Master	Slave 1	Slave 2	System
●	●													
●	◐													
◐	●													
◐	◐													
Master														
Slave 1														
Slave 2														
System														
→	Right-hand system													
→	Left-hand system													
→	—													
→	All systems													

2.2 PCB Abnormality

Remote Controller Display	E1
Applicable Models	RQYQ-PY1B
Method of Error Detection	Abnormality is detected under the communication conditions in the hardware section between the indoor unit and outdoor unit.
Error Decision Conditions	When the communication conditions in the hardware section between the indoor unit and the outdoor unit are not normal.
Supposed Causes	<ul style="list-style-type: none"> ■ Defective outdoor unit PCB (A1P) ■ Defective connection of inside/ outside relay wires

Troubleshooting

 **Caution** Be sure to turn off power switch before connect or disconnect connector, or parts damage may be occurred.

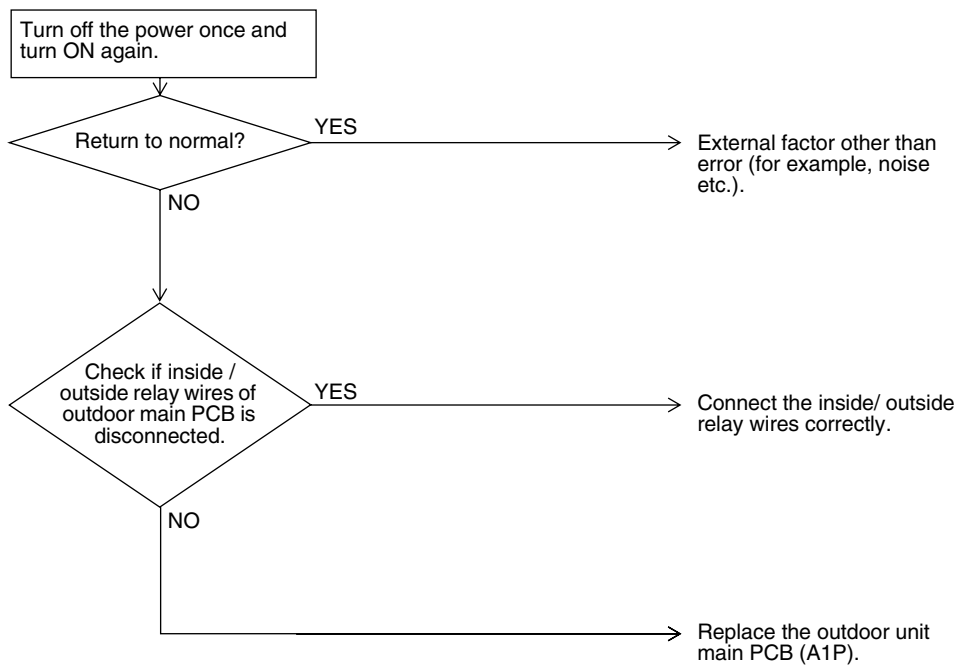

2.3 Actuation of High Pressure Switch or Pressure Switch

Remote Controller Display	
Applicable Models	RQYQ-PY1B
Method of Error Detection	The error is detected by the relationship between "pressure detected by the high pressure sensor" and "operation of the high pressure switch or pressure switch".
Error Decision Conditions	When the high pressure switch or pressure switch operates under low pressure detected by the high pressure sensor during compressor operation. Operating pressure of high pressure switch: 4.0MPa Operating pressure of pressure switch: 3.3MPa
Supposed Causes	<ul style="list-style-type: none"> ■ Defective high pressure sensor ■ Defective connection of connector for high pressure switch or pressure switch ■ Defective high pressure switch or pressure switch

Troubleshooting

Caution

Be sure to turn off power switch before connect or disconnect connector, or parts damage may be occurred.

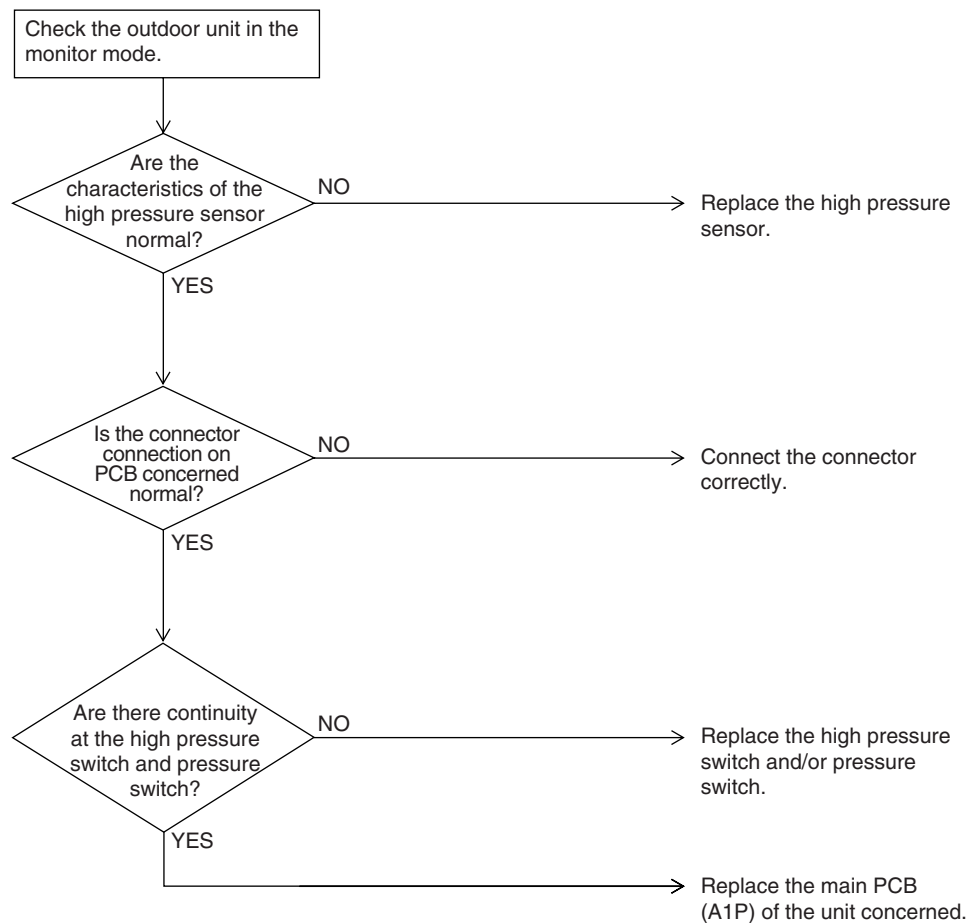

2.4 Actuation of High Pressure Switch (S1PH) or Pressure Switch (S2P)

Remote Controller Display	
Applicable Models	RQYQ-PY1B
Method of Error Detection	Abnormality is detected by the protection device circuit that detects continuity at the high pressure switch and pressure switch.
Error Decision Conditions	<p>When the contact of the high pressure switch or pressure switch opens.</p> <p>(Reference) Operating pressure of high pressure switch Operating pressure: 4.0MPa Reset pressure: 3.0MPa</p> <p>Operating pressure of pressure switch Operating pressure: 3.3MPa Reset pressure: 2.5MPa</p>
Supposed Causes	<ul style="list-style-type: none"> ■ Actuation of outdoor unit high pressure switch or pressure switch ■ Defective high pressure switch or pressure switch ■ Defective outdoor unit main PCB (A1P) ■ Instantaneous power failure ■ Defective high pressure sensor

Troubleshooting

Caution Be sure to turn off power switch before connect or disconnect connector, or parts damage may be occurred.

Check for the points shown below.
 (1) Is the stop valve opened?
 (2) Are the high pressure switch and pressure switch connector properly connected to the main PCB?
 (3) Do the high pressure switch and pressure switch have continuity?



(1) Mount a pressure gauge on the high pressure service port and dual pressure gas stop valve service port.
 (2) Reset the operation using the remote controller, and then restart the operation.

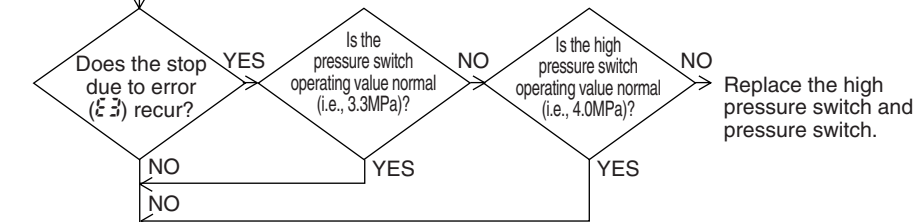

Service Checker
 Connect the service checker to compare the "high pressure" value and the actual measurement value by pressure sensor (*1) by using the service checker.



· The high pressure sensor is normal, and the pressure detected with the PCB are also normal.
 · The high pressure or field piping pressure has really become high.

CHECK 1 Remove the causes by which the high pressure or field piping pressure has become high.



Note:

- *1: Make a comparison between the voltage of the pressure sensor and that read by the pressure gauge. (As to the voltage of the pressure sensor, make measurement of voltage at the connector, and then convert it to pressure.)
- *2: Make measurement of voltage of the pressure sensor.



CHECK 1 Refer to P.179

2.5 Actuation of Low Pressure Sensor

Remote Controller Display	E4
Applicable Models	RQYQ-PY1B
Method of Error Detection	Abnormality is detected by the pressure value of the low pressure sensor with the outdoor unit main PCB (A1P).
Error Decision Conditions	Error is generated when the low pressure is dropped under compressor operation. Operating pressure: 0.07MPa
Supposed Causes	<ul style="list-style-type: none"> ■ Abnormal drop of low pressure ■ Defective low pressure sensor ■ Defective outdoor unit PCB (A1P) ■ Stop valve is not opened.

Troubleshooting

Caution Be sure to turn off power switch before connect or disconnect connector, or parts damage may be occurred.

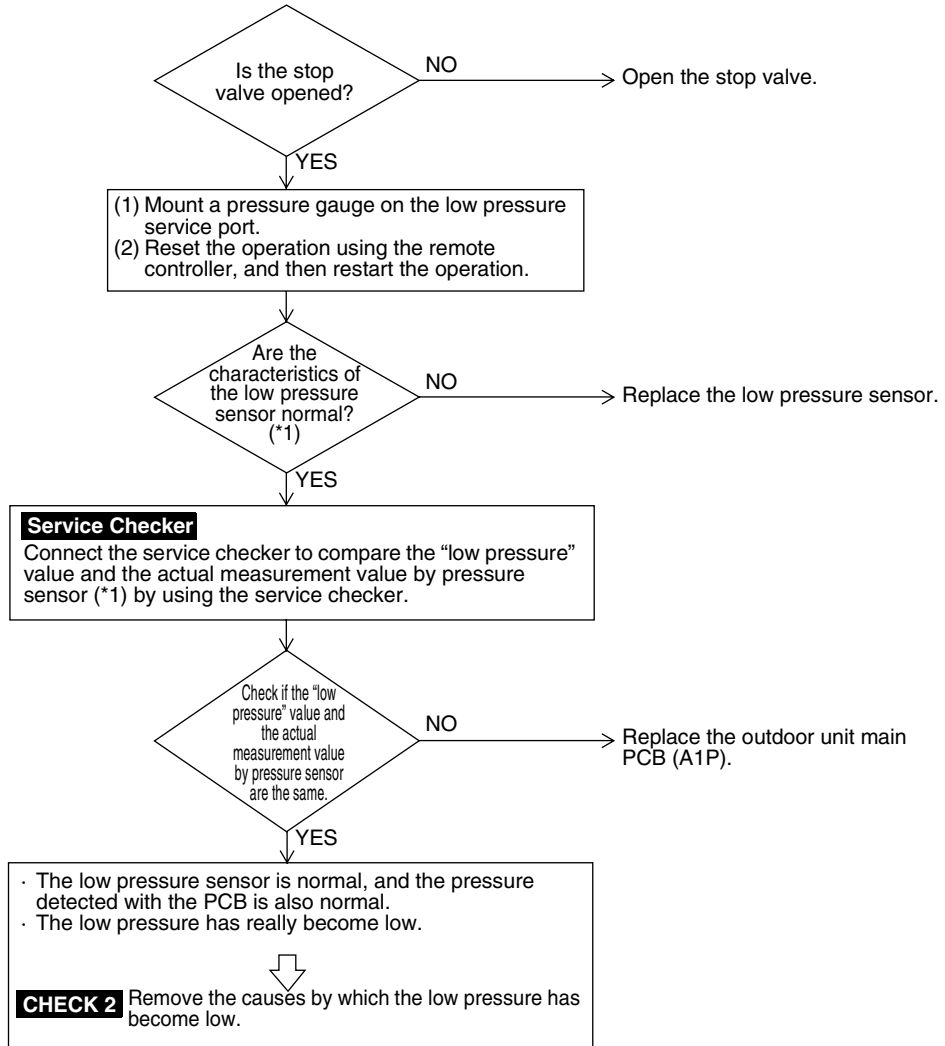

Note:

*1: Make a comparison between the voltage of the pressure sensor and that read by the pressure gauge.
 (As to the voltage of the pressure sensor, make measurement of voltage at the connector, and then convert it to pressure.)

*2: Make measurement of voltage of the pressure sensor.

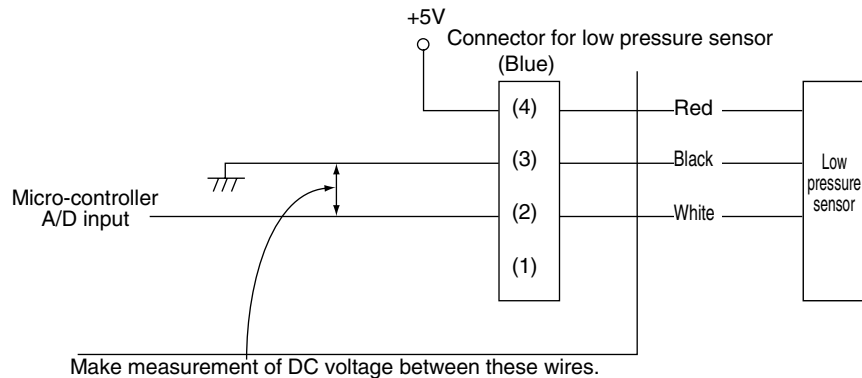

CHECK 2 Refer to P.180

2.6 Inverter Compressor Motor Lock

Remote Controller Display	E5
Applicable Models	RQYQ-PY1B
Method of Error Detection	Inverter PCB takes the position signal from UVW line connected between the inverter and compressor, and the error is detected when any abnormality is observed in the phase-current waveform.
Error Decision Conditions	This error will be output when the inverter compressor motor does not start up even in forced startup mode.
Supposed Causes	<ul style="list-style-type: none"> ■ Inverter compressor lock ■ High differential pressure (0.5MPa or more) ■ Incorrect UVW wiring ■ Faulty inverter PCB ■ Stop valve is not opened.

Troubleshooting



Caution

Be sure to turn off power switch before connect or disconnect connector, or parts damage may be occurred.

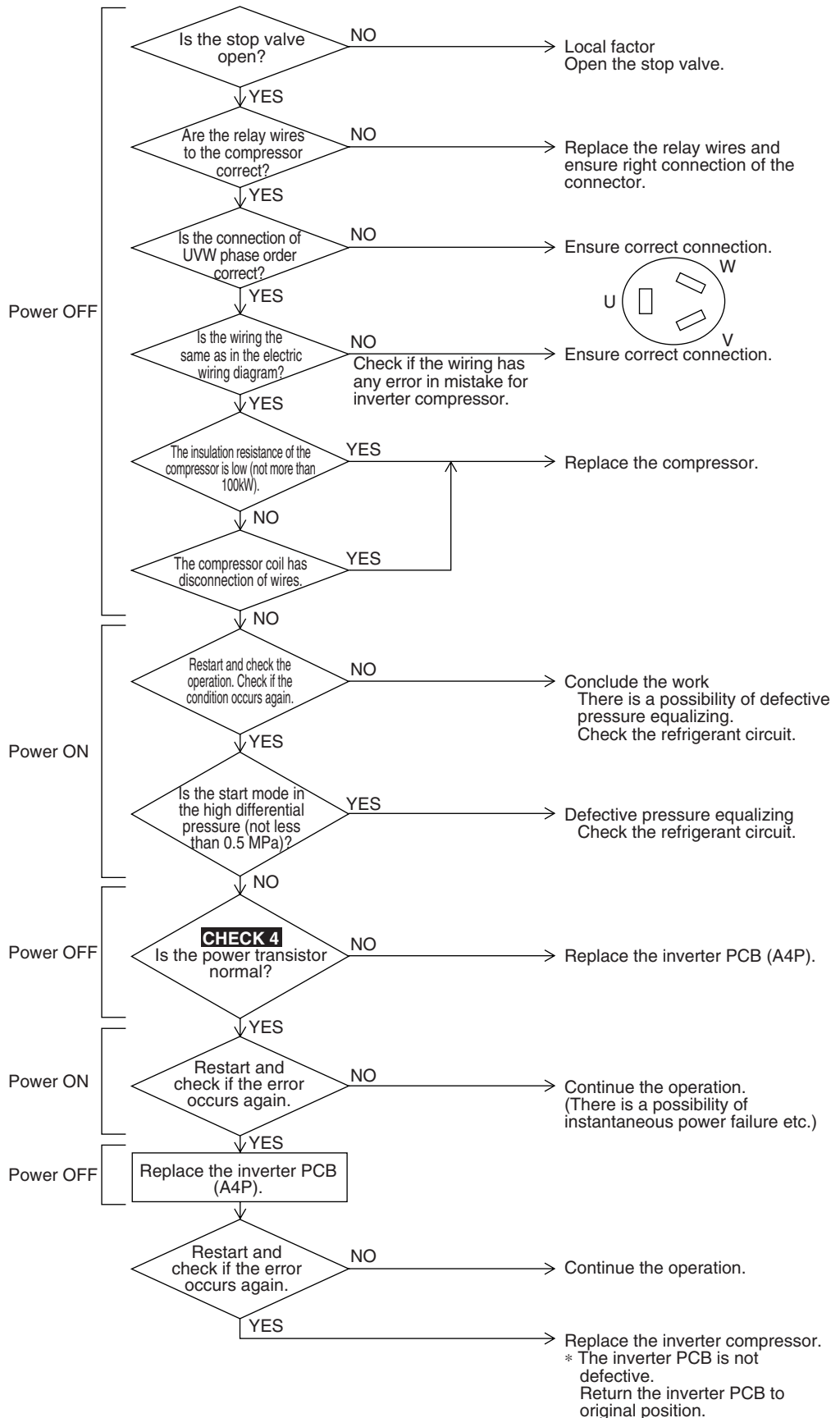

CHECK 4 Refer to P.182

2.7 STD Compressor Motor Overcurrent/Lock

Remote Controller Display	
Applicable Models	RQYQ10P~16PY1B
Method of Error Detection	Detects the overcurrent with current sensor (CT).
Error Decision Conditions	Error is decided when the detected current value exceeds 28.8 A for 2 seconds.
Supposed Causes	<ul style="list-style-type: none"> ■ Stop valve is not opened ■ Obstacles at the air outlet ■ Improper power supply voltage ■ Defective magnetic switch ■ Defective compressor ■ Defective current sensor (A6P, A8P)

Troubleshooting



Caution

Be sure to turn off power switch before connect or disconnect connector, or parts damage may be occurred.

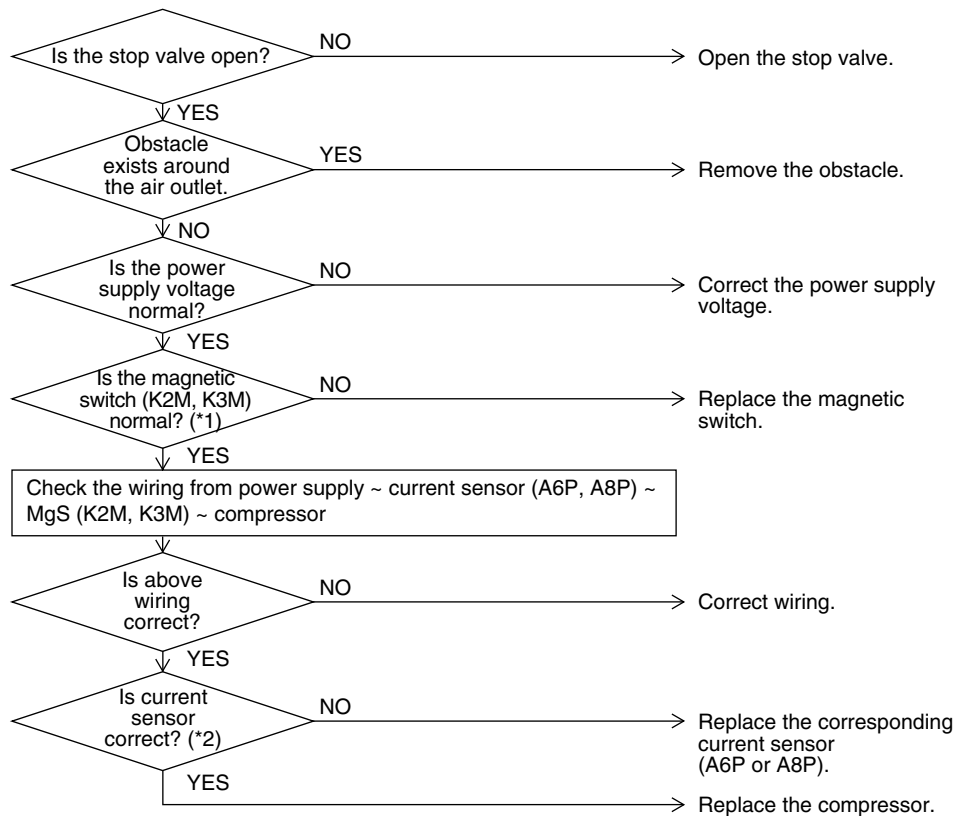

Note:

*1. One of the possible factors may be chattering due to rough MgS contact.

*2. Abnormal case

- The current sensor value is 0 during STD compressor operation.
- The current sensor value is more than 15.0A during STD compressor stop.

2.8 Outdoor Unit Fan Motor Abnormality

Remote Controller Display	E7
Applicable Models	RQYQ-PY1B
Method of Error Detection	<ol style="list-style-type: none"> ① Detect an error based on the current value in the inverter PCB (as for motor 2, current value in the fan PCB). ② Detect an error malfunction for the fan motor circuit based on the number of rotation detected by hole IC during the fan motor operation.
Error Decision Conditions	<ul style="list-style-type: none"> ■ Overcurrent is detected for inverter PCB (A4P) or fan inverter PCB (A5P or A7P) (System down is caused by 4 times of detection.) ■ In the condition of fan motor rotation, the number of rotation is below the fixed number for more than 6 seconds. (System down is caused by 4 times of detection.)
Supposed Causes	<ul style="list-style-type: none"> ■ Defective fan motor ■ Defective or connection error of the connectors/ harness between the fan motor and PCB ■ The fan can not rotate due to any foreign substances entangled. ■ Clear condition: Continue normal operation for 5 minutes

Troubleshooting

Caution Be sure to turn off power switch before connect or disconnect connector, or parts damage may be occurred.

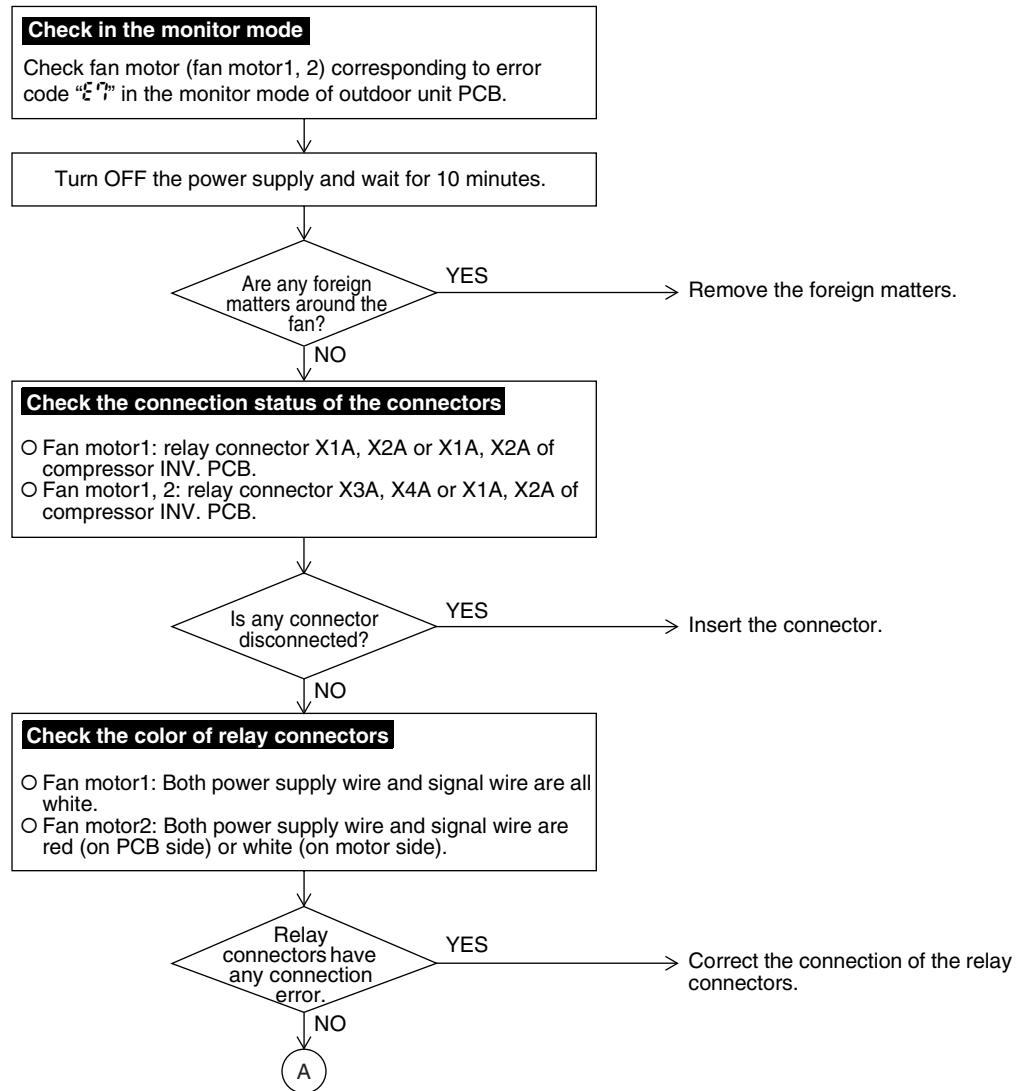

RQYQ8PY1B
RQYQ10PY1B
RQYQ12PY1B

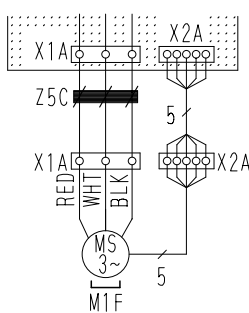

RQYQ14PY1B
RQYQ16PY1B

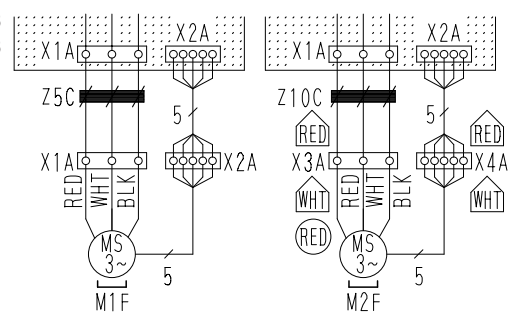

Troubleshooting

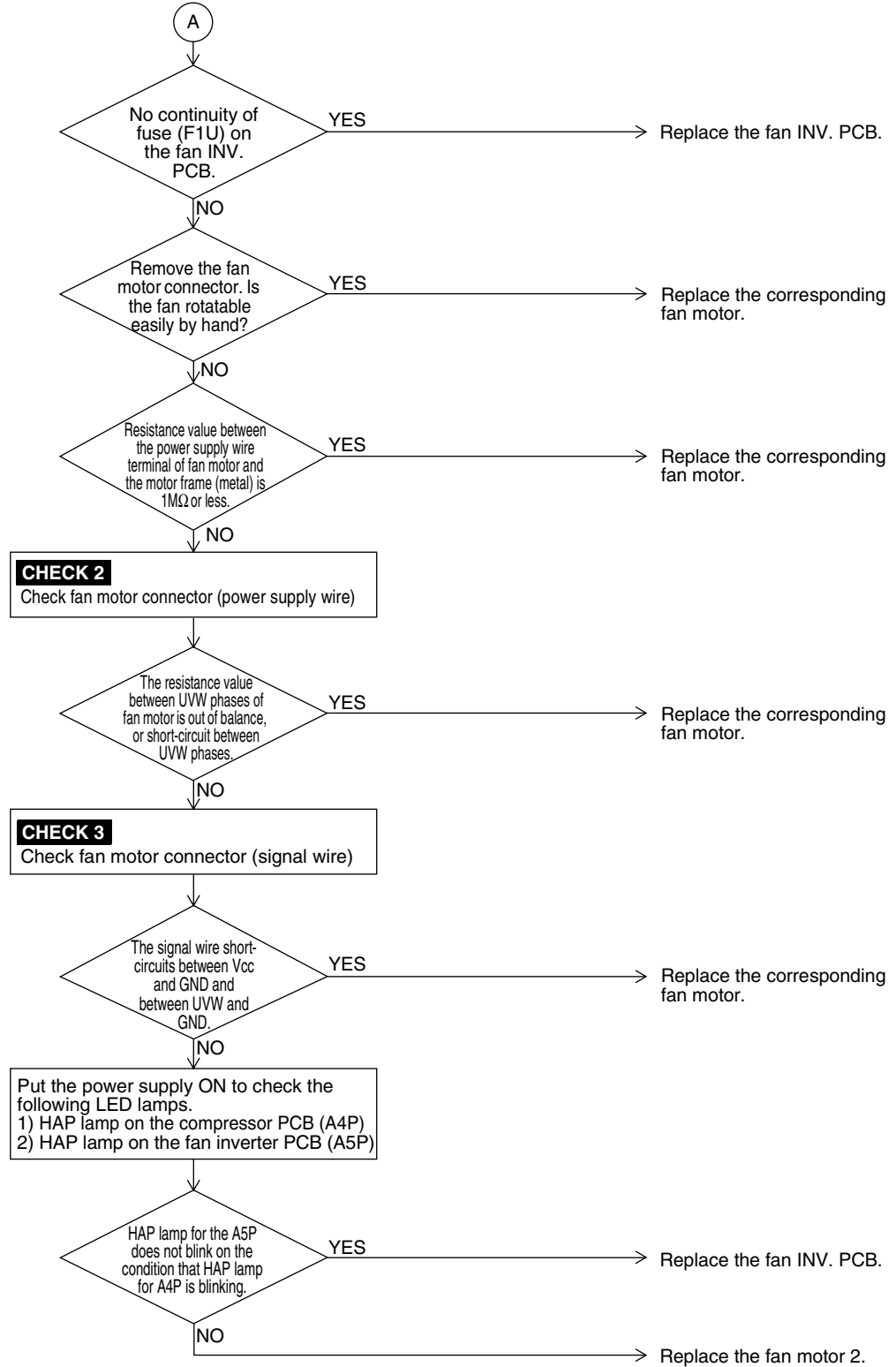

CHECK 2 Refer to P.180



CHECK 3 Refer to P.181

2.9 Electronic Expansion Valve Coil Abnormality (Y1E~Y3E)

Remote Controller Display	
Applicable Models	RQYQ-PY1B
Method of Error Detection	Check the continuity of electronic expansion valve coil (Y1E)
Error Decision Conditions	No current is detected in the common (COM [+]) when power supply is ON.
Supposed Causes	<ul style="list-style-type: none"> ■ Disconnection of connectors for electronic expansion valve (Y1E) ■ Defective electronic expansion valve coil ■ Defective outdoor unit main PCB (A1P)

Troubleshooting

Caution Be sure to turn off power switch before connect or disconnect connector, or parts damage may be occurred.

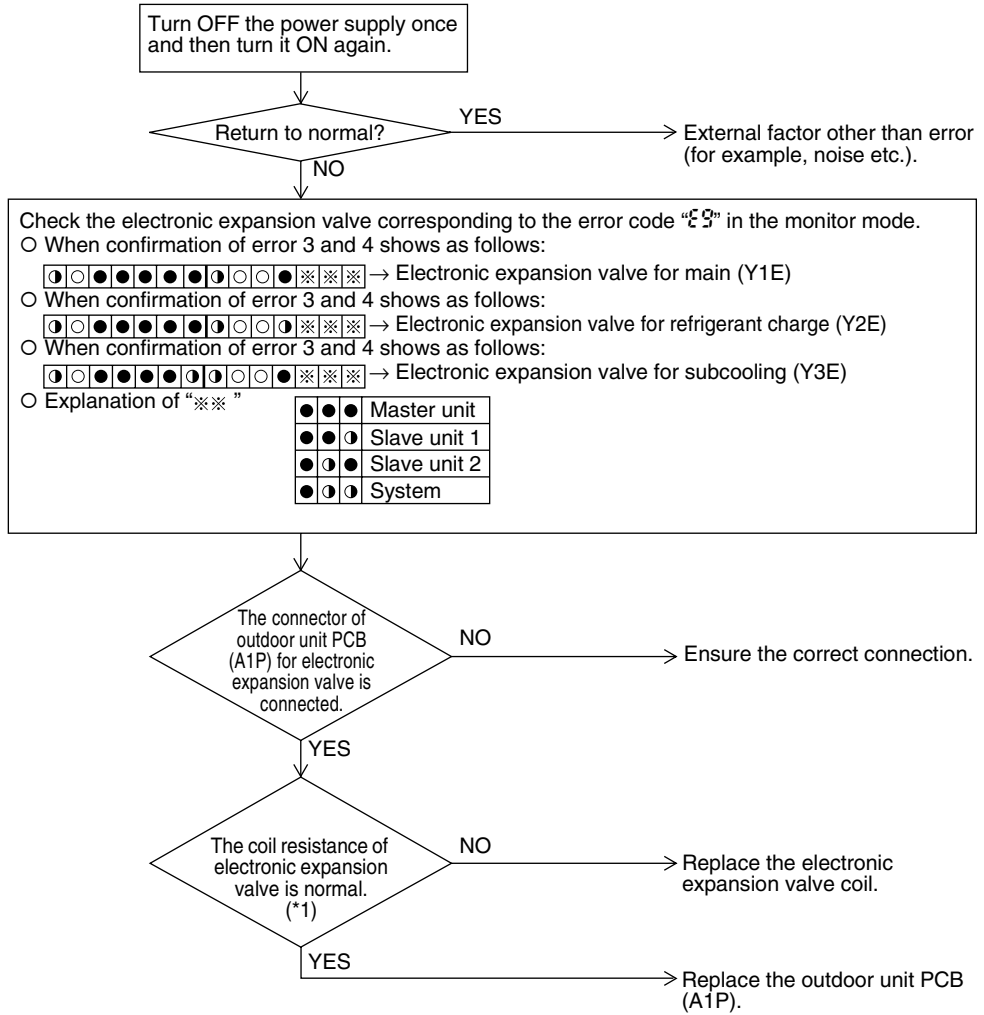

Note:

*1. Make measurement of resistance between the connector pins, and then make sure the resistance falls in the range of 40 to 50W.

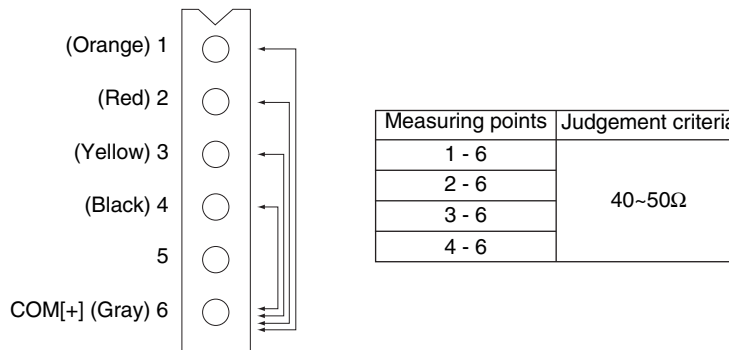

2.10 Abnormal Discharge Pipe Temperature

Remote Controller Display	
Applicable Models	RQYQ-PY1B
Method of Error Detection	The error is detected according to the temperature detected by the discharge pipe temperature sensor.
Error Decision Conditions	When the discharge pipe temperature rises to an abnormally high level (135 °C or more) When the discharge pipe temperature rises suddenly (120 °C or more continues for 10 minutes)
Supposed Causes	<ul style="list-style-type: none"> ■ Defective discharge pipe temperature ■ Defective discharge pipe thermistor ■ Defective outdoor unit PCB (A1P)

Troubleshooting



Caution

Be sure to turn off power switch before connect or disconnect connector, or parts damage may be occurred.

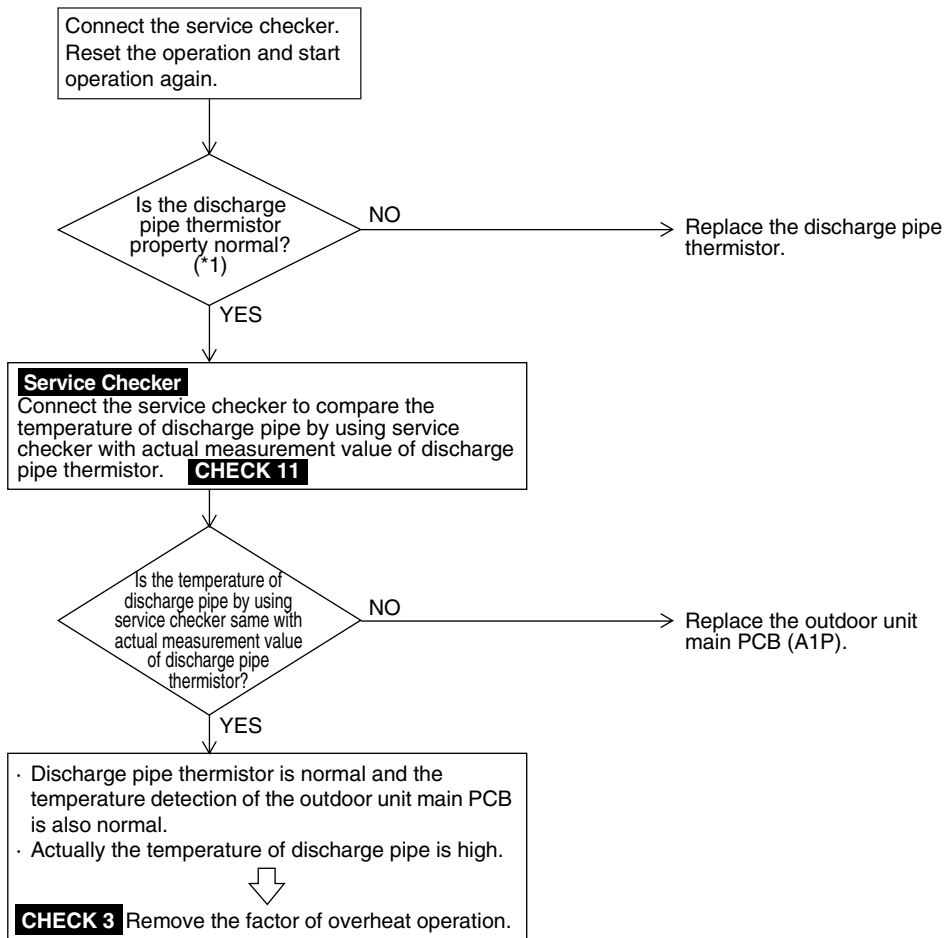

CHECK 3 Refer to P.181



CHECK 11 Refer to P.190



Note:

*1: Compare the resistance value of discharge pipe thermistor and the value based on the surface thermometer.

2.11 Humidity Alarm

Remote Controller Display	F4
Applicable Models	RQYQ-PY1B
Method of Error Detection	The condition of the liquid refrigerant returning to the compressor is detected by the temperature and pressure of any part during the cooling operation.
Error Decision Conditions	When the following humidity condition continues for 30 minutes & <ul style="list-style-type: none"> • Humidity condition in the indoor unit • Humidity condition in some indoor units
Supposed Causes	<ul style="list-style-type: none"> ■ Defective suction pipe thermistor ■ Defective discharge pipe thermistor ■ Defective high pressure sensor ■ Defective indoor unit electronic expansion valve ■ Contamination of the air filter

Troubleshooting

**Caution**

Be sure to turn off power switch before connect or disconnect connector, or parts damage may be occurred.

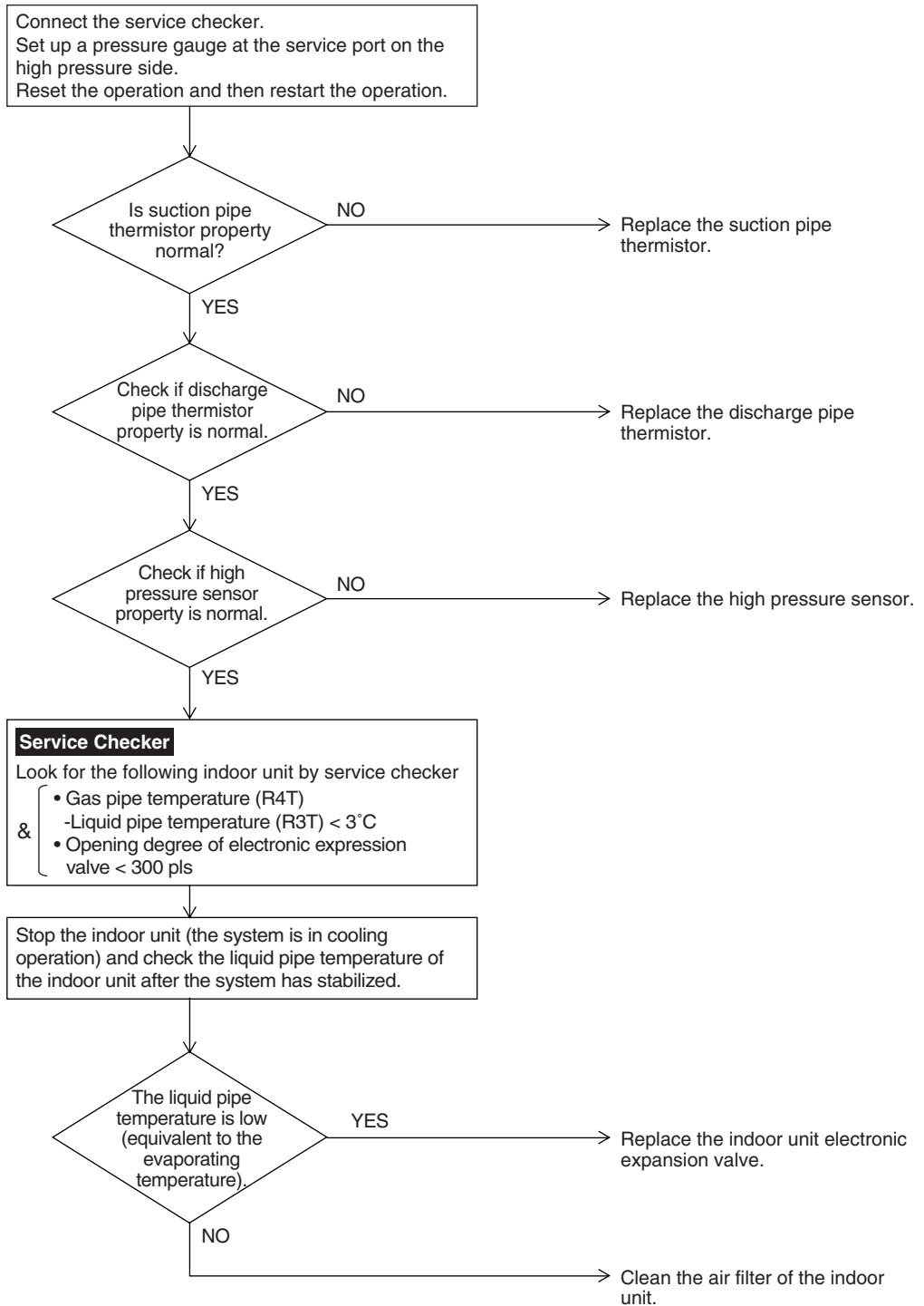

2.12 Refrigerant Overcharged

Remote Controller Display	
Applicable Models	RQYQ-PY1B
Method of Error Detection	Excessive charging of refrigerant is detected by using the outdoor air temperature, heat exchanger deicer temperature and liquid pipe temperature during check operation.
Error Decision Conditions	When the amount of refrigerant, which is calculated by using the outdoor air temperature, heat exchanger deicer temperature and liquid pipe temperature during check operation, exceeds the criteria.
Supposed Causes	<ul style="list-style-type: none"> ■ Refrigerant overcharge ■ Disconnection of outdoor air thermistor ■ Disconnection of heat exchanger deicer thermistor ■ Disconnection of liquid pipe thermistor

Troubleshooting

 **Caution** Be sure to turn off power switch before connect or disconnect connector, or parts damage may be occurred.

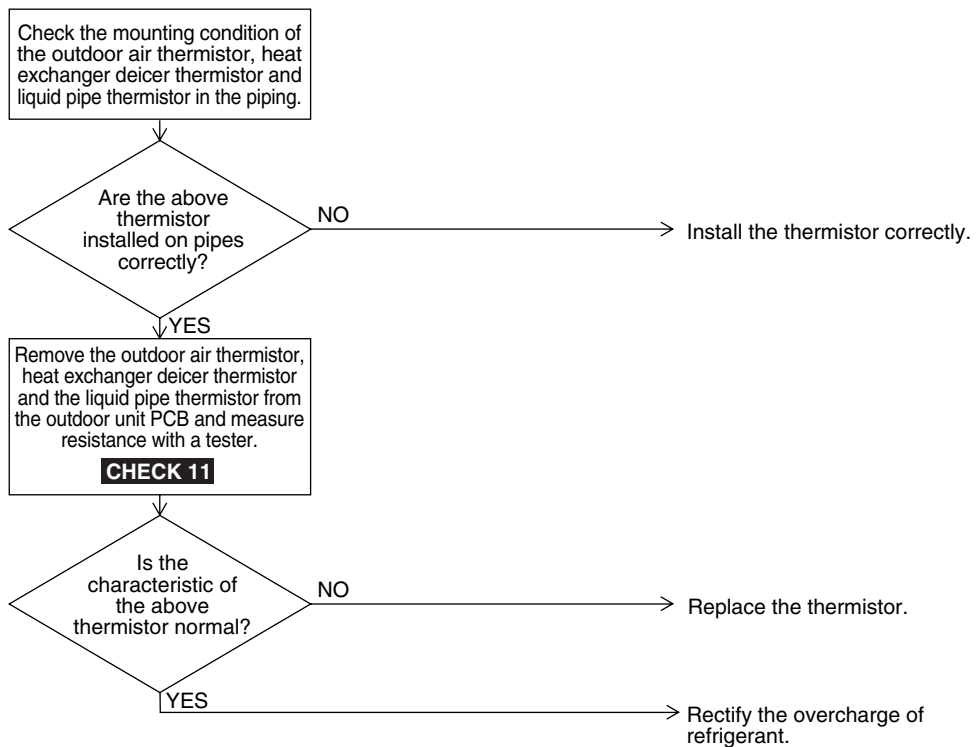

CHECK 11 Refer to P.189

2.13 High Pressure Switch System Abnormality

Remote Controller Display	H3
Applicable Models	RQYQ-PY1B
Method of Error Detection	The protection device circuit checks continuity in the high pressure switch.
Error Decision Conditions	When there is no continuity in the high pressure switch when the compressor stops operating.
Supposed Causes	<ul style="list-style-type: none"> ■ Defective high pressure switch ■ Broken of high pressure switch harness ■ Defective connection of high pressure switch connector ■ Defective compressor ■ Defective outdoor unit PCB ■ Broken of lead wire

Troubleshooting



Caution Be sure to turn off power switch before connect or disconnect connector, or parts damage may be occurred.

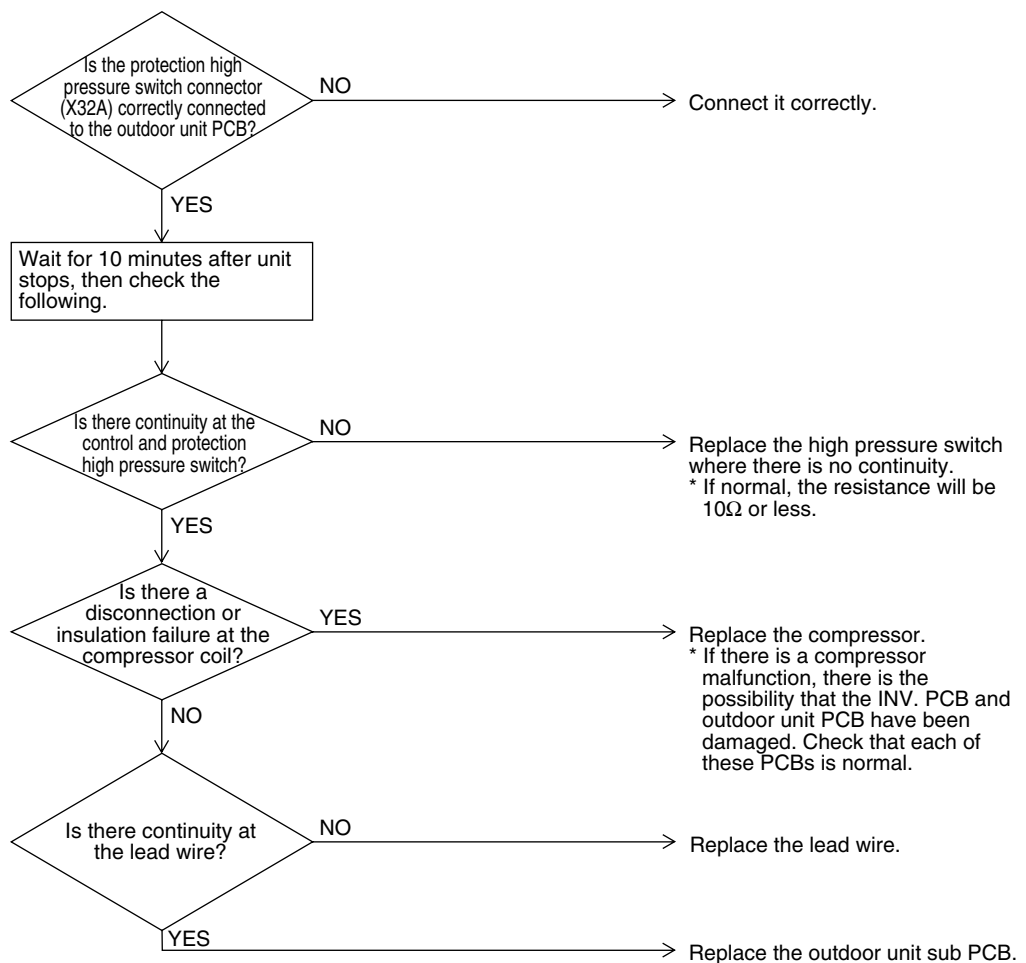



2.14 Abnormal Outdoor Fan Motor Signal

Remote Controller Display	H7
Applicable Models	RQYQ-PY1B
Method of Error Detection	Detection of abnormal signal from fan motor.
Error Decision Conditions	In case of detection of abnormal signal at starting fan motor.
Supposed Causes	<ul style="list-style-type: none"> ■ Abnormal fan motor signal (circuit error) ■ Broken, short or disconnection connector of fan motor lead wire ■ Defective fan INV. PCB

Troubleshooting

Caution Be sure to turn off power switch before connect or disconnect connector, or parts damage may be occurred.

Check the fan motor corresponding to the error code “H” in the monitor mode.
 When confirmation of error 3 shows as follows:
 → Fan motor 1 (M1F)
 When confirmation of error 3 shows as follows:
 → Fan motor (M2F)
 Explanation for “※※”

●	●	●	Master unit
●	●	○	Slave unit 1
●	○	●	Slave unit 2
●	○	○	System

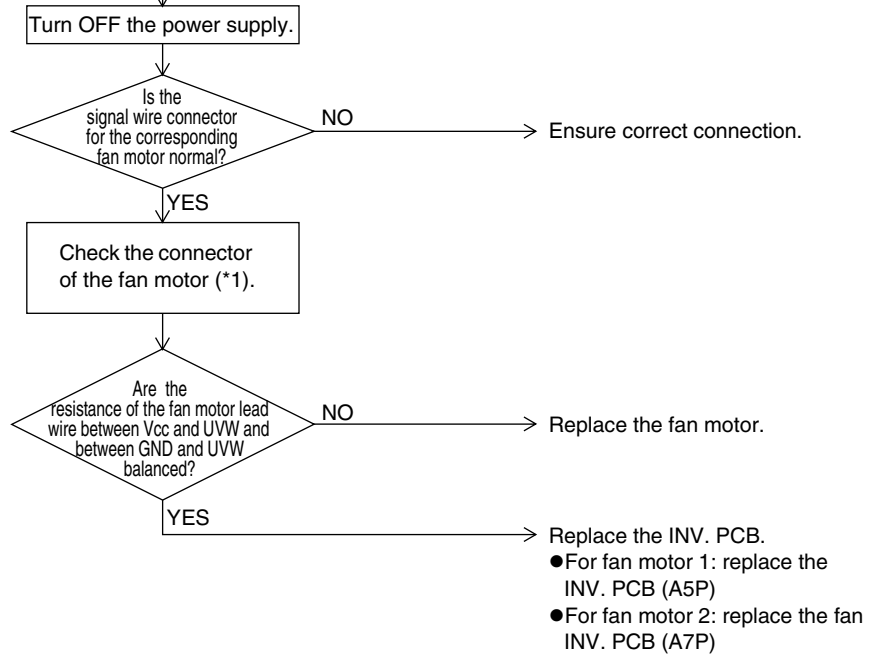

Note:

- *1. Check the procedure for fan motor connector
 - (1) Power OFF the fan motor.
 - (2) Remove the connector (X2A or X4A) on the PCB to measure the following resistance value.
 Judgement criteria: resistance value between each phase is within ±20%

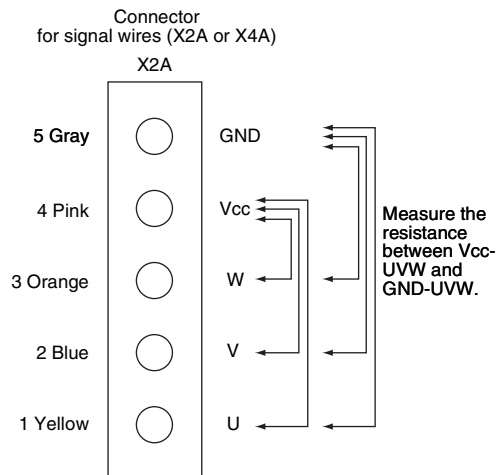

2.15 Thermistor System Abnormality

Remote Controller Display	H9, J3, J5, J6, J7, J8, J9
Applicable Models	RQYQ-PY1B
Method of Error Detection	The error is detected according to the temperature detected by each individual thermistor.
Error Decision Conditions	When thermistor is disconnected or short-circuited during operation
Supposed Causes	<ul style="list-style-type: none"> ■ Defective thermistor ■ Defective connection of connector ■ Defective outdoor unit PCB (service monitor PCB)

Troubleshooting



Caution Be sure to turn off power switch before connect or disconnect connector, or parts damage may be occurred.

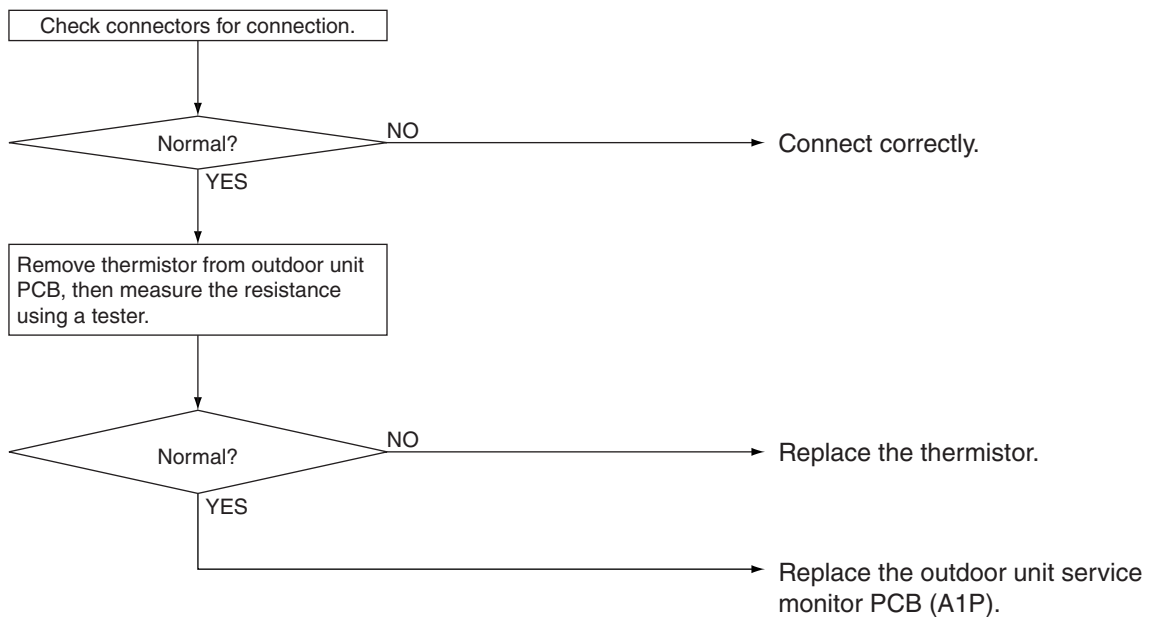

Error code	Defective thermistor	RQYQ8PY1B		RQYQ10•12PY1B		RQYQ14•16PY1B	
		Symbol	Connector	Symbol	Connector	Symbol	Connector
H9	Outdoor air thermistor	R1T	X18A	R1T	X18A	R1T	X18A
J3	Discharge pipe thermistor	R3T	X29A	R31T	X29A	R31T	X29A
		—	—	R32T		R32T	
		—	—	—		R33T	
J5	Suction pipe thermistor	R8T	X11A	R8T	X11A	R8T	X11A
J6	Heat exchanger deicer thermistor	R9T	X12A	R9T	X12A	R9T	X12A
J7	Liquid pipe thermistor	R6T	X30A	R6T	X30A	R6T	X30A
J8	Receiver gas vet outlet thermistor	R7T	X30A	R7T	X30A	R7T	X30A
	Receiver liquid level thermistor	R2T	X30A	R2T	X30A	R2T	X30A
	Refrigerant regulator liquid pipe thermistor	R4T	X30A	R4T	X30A	R4T	X30A
J9	Subcooling heat exchanger outlet thermistor	R5T	X30A	R5T	X30A	R5T	X30A

2.16 High Pressure Sensor Abnormality

Remote Controller Display



Applicable Models

RQYQ-PY1B

Method of Error Detection

Error is detected from the pressure measured with high pressure sensor.

Error Decision Conditions

When the high pressure sensor is short circuit or open circuit.
(Not less than 4.22MPa, or 0.01MPa or less)

Supposed Causes

- Defective high pressure sensor
- Connection of low pressure sensor with wrong connection.
- Defective outdoor unit PCB.
- Defective connection of high pressure sensor

Troubleshooting



Caution

Be sure to turn off power switch before connect or disconnect connector, or parts damage may be occurred.

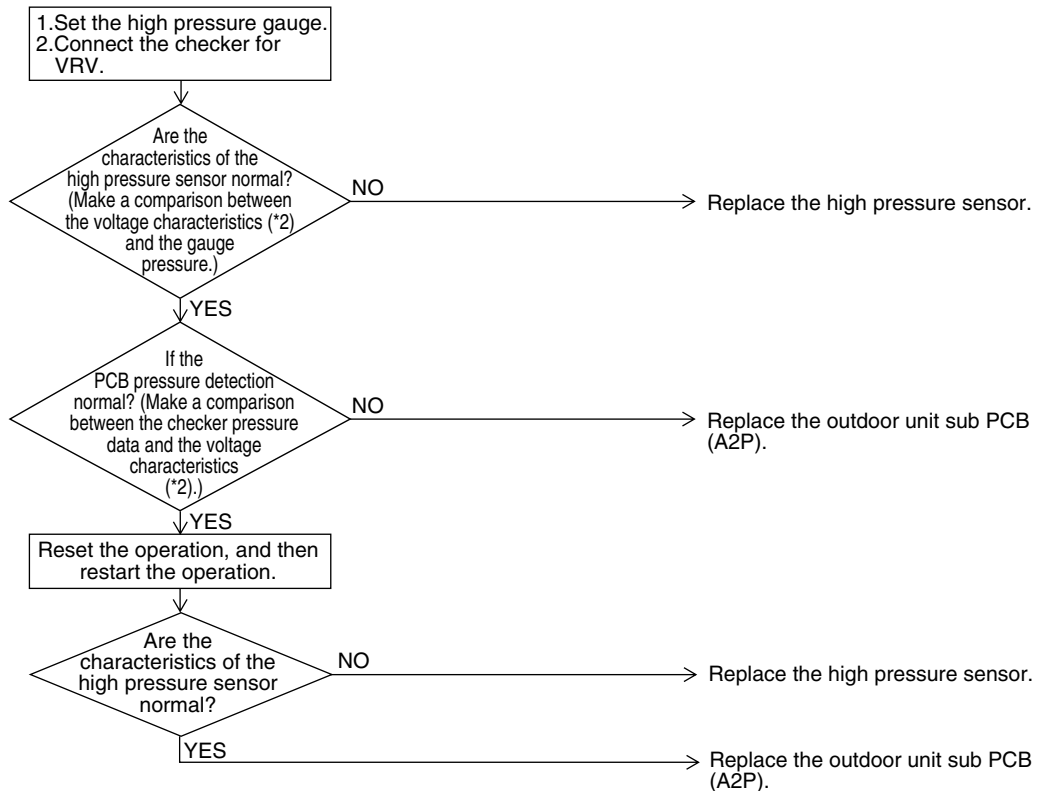

Note:

*1. Pressure sensor subject to error code

Error code	Pressure sensor subject to error code	Electric symbol
J1	High pressure sensor (Liquid pipe outlet)	S2NPH

*2. Voltage measurement point

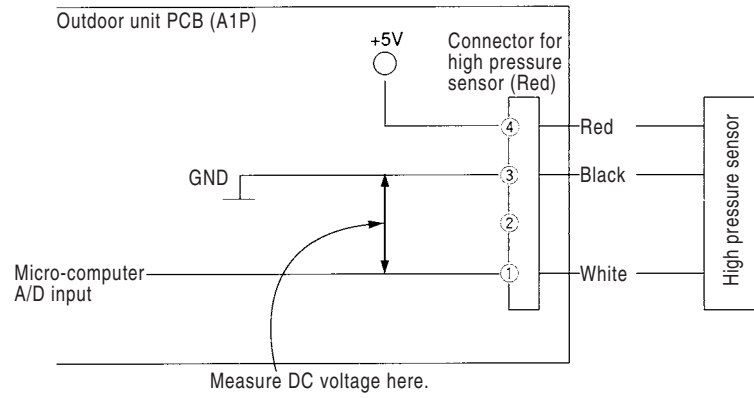

CHECK 12 Refer to P.191

2.17 Current Sensor Abnormality

Remote
Controller
Display



Applicable
Models

RQYQ-PY1B

Method of Error
Detection

Error is detected from the current value detected by current sensor.

Error Decision
Conditions

When the current value detected by current sensor becomes 5A or less, or 40A or more during STD compressor operation.

Supposed
Causes

- Defective current sensor (A6P, A8P)
- Defective outdoor unit PCB
- Defective compressor

Troubleshooting



Caution

Be sure to turn off power switch before connect or disconnect connector, or parts damage may be occurred.

Check the current sensor corresponding to the error code "u2" in the monitor mode.

- Confirmation of error 4 shows as follows:
 → Current sensor for STD compressor 1
- Confirmation of error 4 shows as follows:
 → Current sensor for STD compressor 2
- Explanation for "※※"

<input checked="" type="checkbox"/>	<input checked="" type="checkbox"/>	Master unit
<input checked="" type="checkbox"/>	<input type="checkbox"/>	Slave unit 1
<input type="checkbox"/>	<input checked="" type="checkbox"/>	Slave unit 2
<input type="checkbox"/>	<input type="checkbox"/>	System

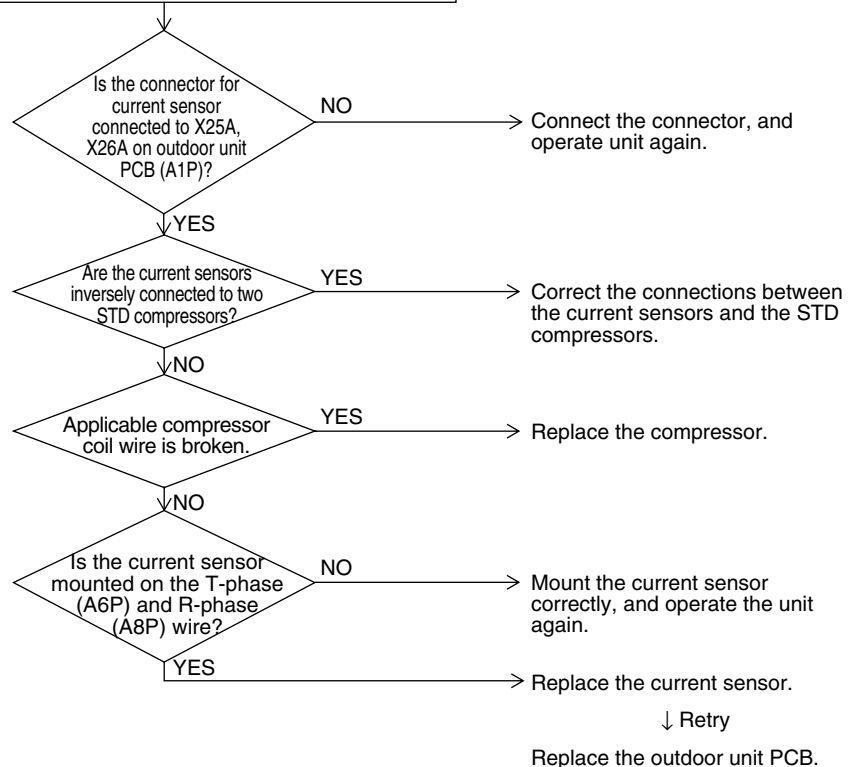

2.18 High Pressure Sensor Abnormality

<p>Remote Controller Display</p>	
<p>Applicable Models</p>	<p>RQYQ-PY1B</p>
<p>Method of Error Detection</p>	<p>Error is detected from the pressure detected by the high pressure sensor.</p>
<p>Error Decision Conditions</p>	<p>When the high pressure sensor is short-circuit or open circuit. (Not less than 4.22MPa, or 0.01MPa or less)</p>
<p>Supposed Causes</p>	<ul style="list-style-type: none"> ■ Defective high pressure sensor ■ Connection of low pressure sensor with wrong connection. ■ Defective outdoor unit PCB ■ Defective connection of high pressure sensor

Troubleshooting

Caution Be sure to turn off power switch before connect or disconnect connector, or parts damage may be occurred.

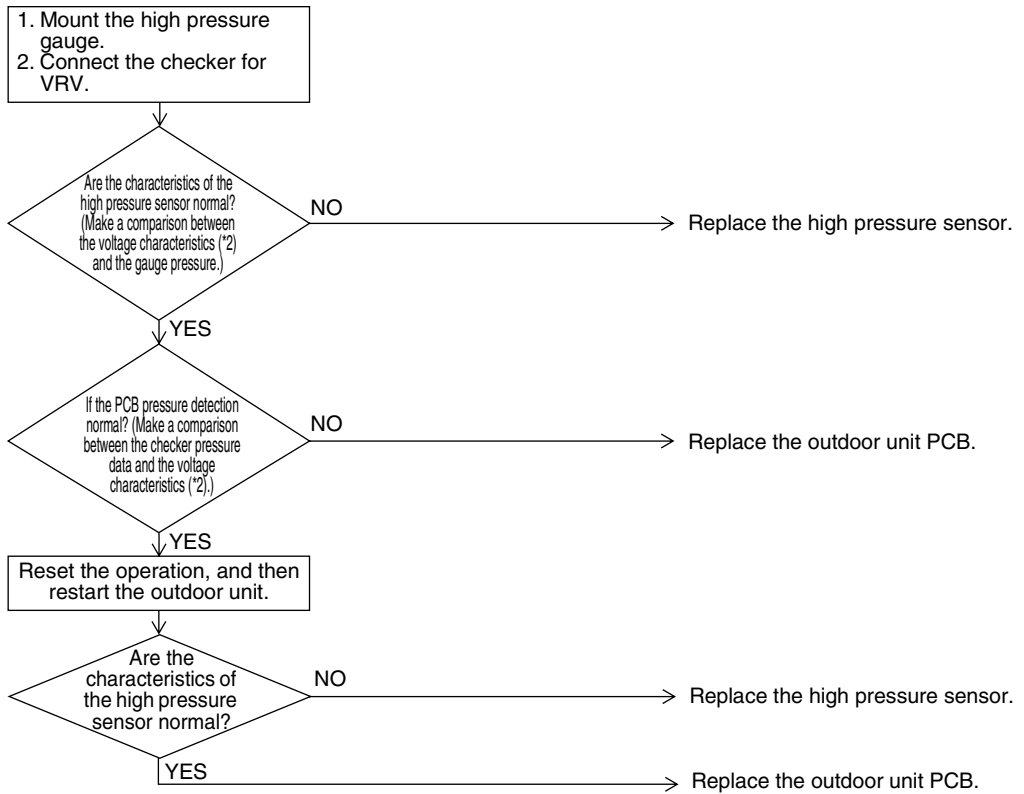

Note:

*1. Pressure sensor subject to error code

Malfunction code	Pressure sensor subject to error code	Electric symbol
JA	High pressure sensor	S1NPH

*2. Voltage measurement point

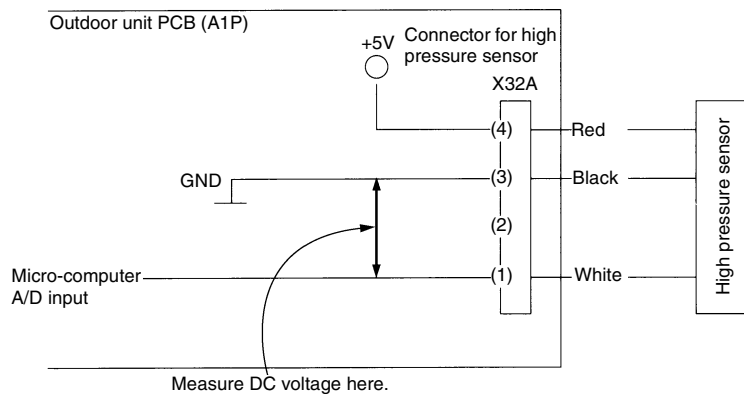

CHECK 12 Refer to P.191

2.19 Low Pressure Sensor Abnormality

Remote Controller Display	
Applicable Models	RQYQ-PY1B
Method of Error Detection	Error is detected from the pressure detected by the low pressure sensor.
Error Decision Conditions	When the low pressure sensor is short circuit or open circuit. (Not less than 1.77MPa, or -0.01MPa and below)
Supposed Causes	<ul style="list-style-type: none"> ■ Defect of low pressure sensor ■ Connection of high pressure sensor with wrong connection. ■ Defect of outdoor unit PCB ■ Defective connection of low pressure sensor

Troubleshooting

 **Caution** Be sure to turn off power switch before connect or disconnect connector, or parts damage may be occurred.

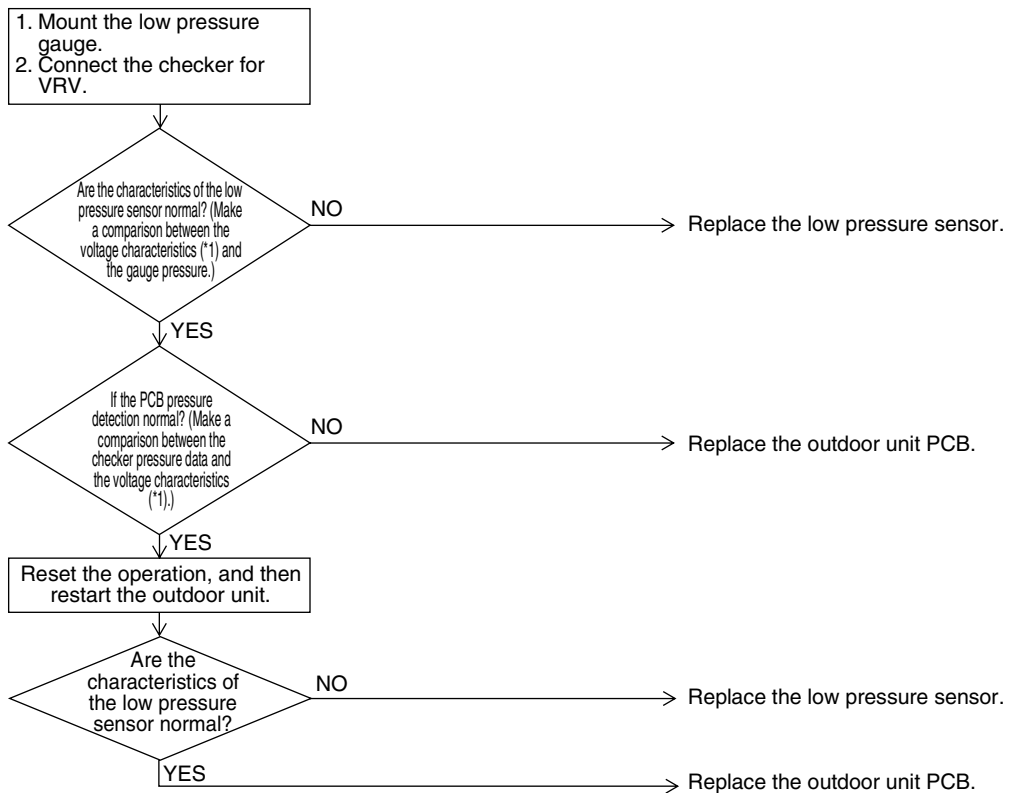



Note:

*1. Voltage measurement point

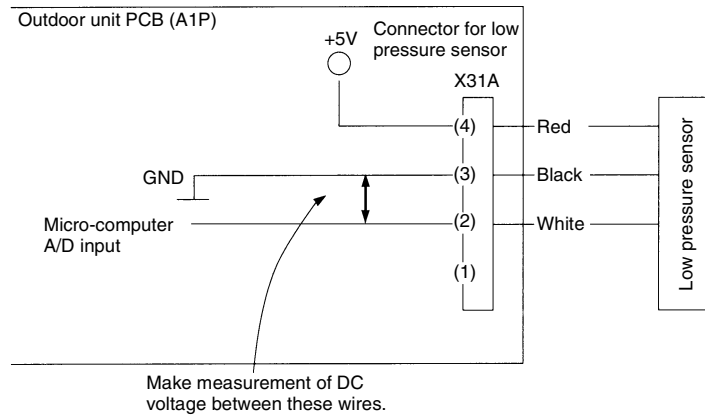

CHECK 12 Refer to P.191

2.20 Inverter PCB Abnormality

Remote Controller Display	L I
Applicable Models	RQYQ-PY1B
Method of Error Detection	<ul style="list-style-type: none"> ■ Detect error by current value during waveform output before compressor startup. ■ Detect error by current sensor value during synchronized operation at the time of startup.
Error Decision Conditions	<ul style="list-style-type: none"> ■ When over-current is detected at the time of waveform output before operating the compressor ■ When the current sensor error during synchronized operation ■ When overvoltage occurs in IPM
Supposed Causes	<ul style="list-style-type: none"> ■ Defective outdoor unit PCB (A1P) <ul style="list-style-type: none"> • IPM failure • Current sensor failure • Defective drive circuit

Troubleshooting



Caution

Be sure to turn off power switch before connect or disconnect connector, or parts damage may be occurred.

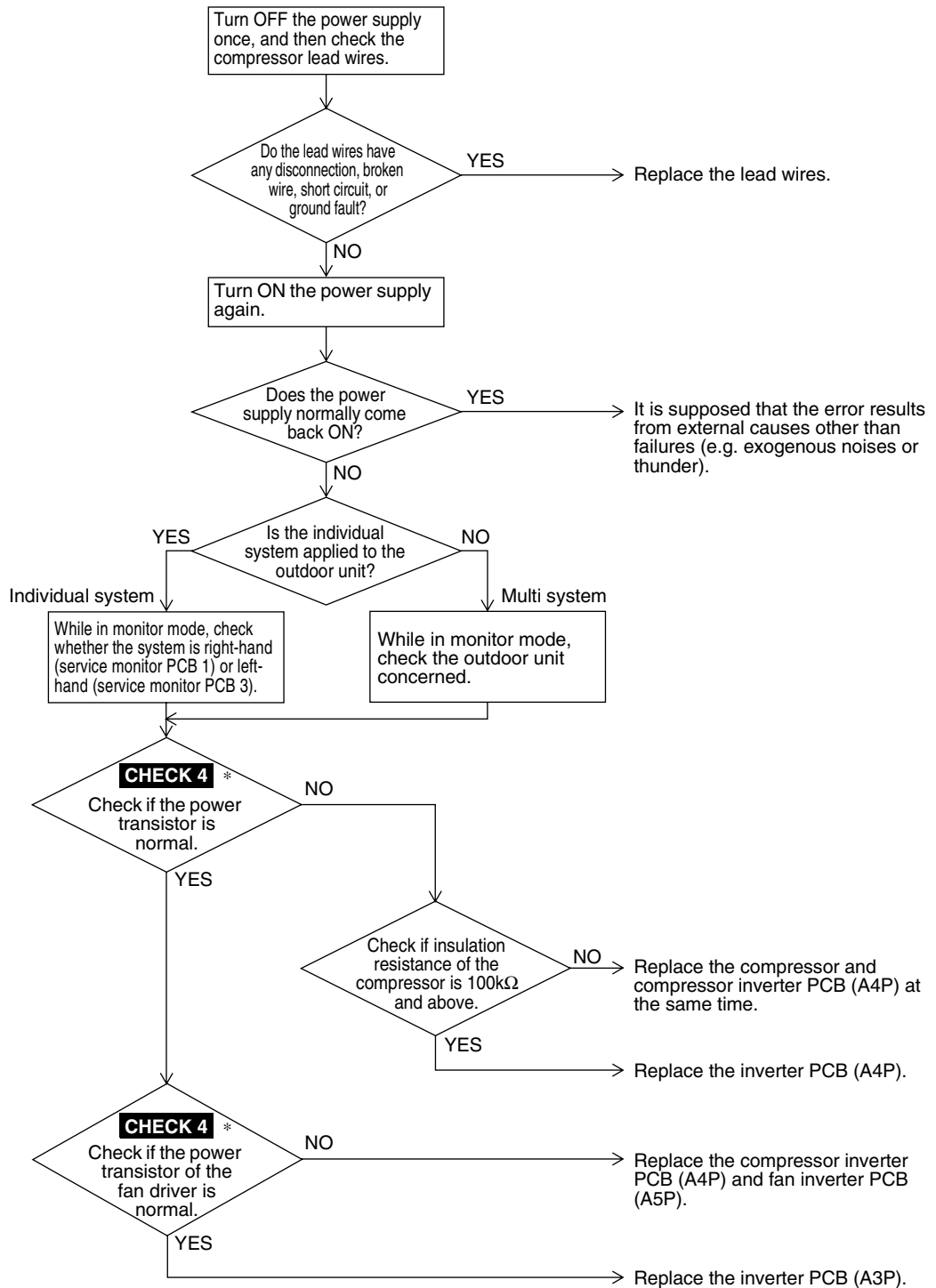

* **CHECK 4** : Referring to the information on P.182.

2.21 Inverter Radiation Fin Temperature Rise

Remote Controller Display	
Applicable Models	RQYQ-PY1B
Method of Error Detection	Radiation of compressor inverter PCB. Fin temperature is detected by the radiation fin thermistor.
Error Decision Conditions	When the temperature of the inverter radiation fin increases above 87°C.
Supposed Causes	<ul style="list-style-type: none"> ■ Actuation of fin thermal (Actuates above 87°C) ■ Defective inverter PCB ■ Defective radiation fin thermistor

Troubleshooting

 **Caution** Be sure to turn off power switch before connect or disconnect connector, or parts damage may be occurred.

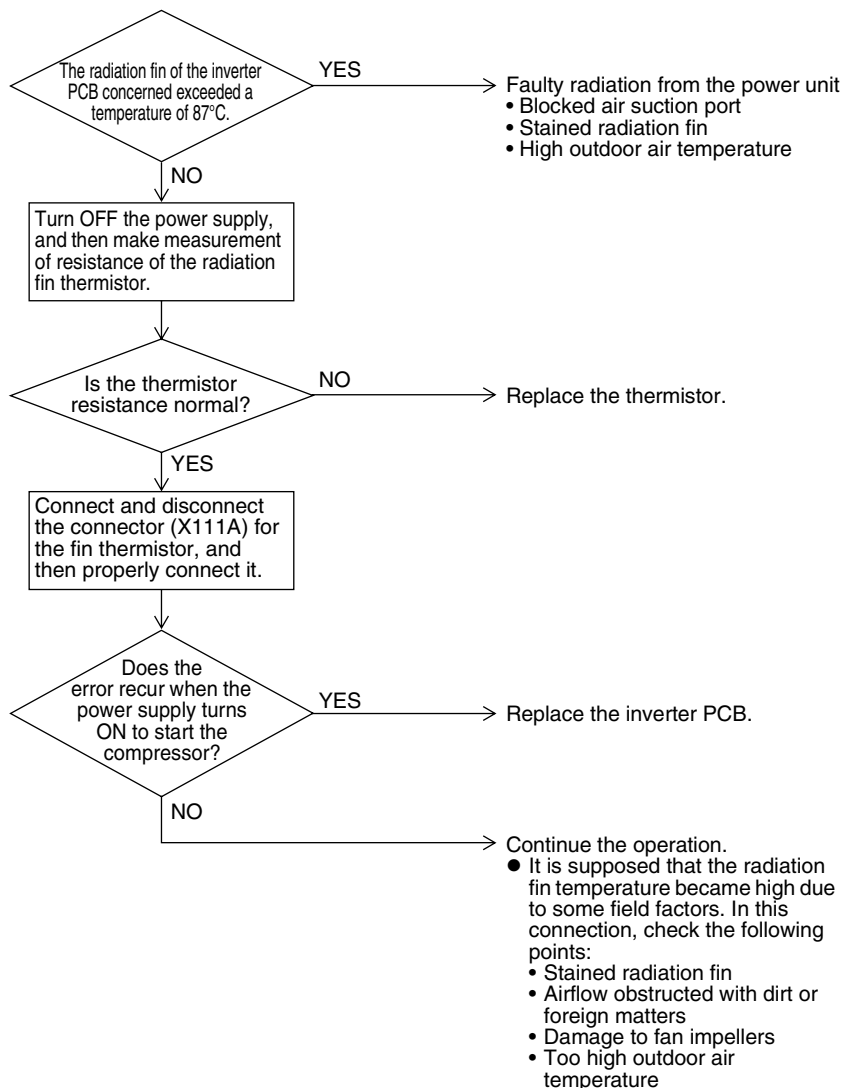

2.22 Momentary Overcurrent of Inverter Compressor

**Remote
Controller
Display**

U5

**Applicable
Models**

RQYQ-PY1B

**Method of Error
Detection**

Error is detected from the current flowing in the power transistor.

**Error Decision
Conditions**

When an excessive current (59.1A) flows in the power transistor.
(Instantaneous overcurrent also causes activation.)

**Supposed
Causes**

- Defective compressor coil (disconnected, defective insulation)
- Compressor startup error (mechanical lock)
- Defective inverter PCB

Troubleshooting



Caution

Be sure to turn off power switch before connect or disconnect connector, or parts damage may be occurred.

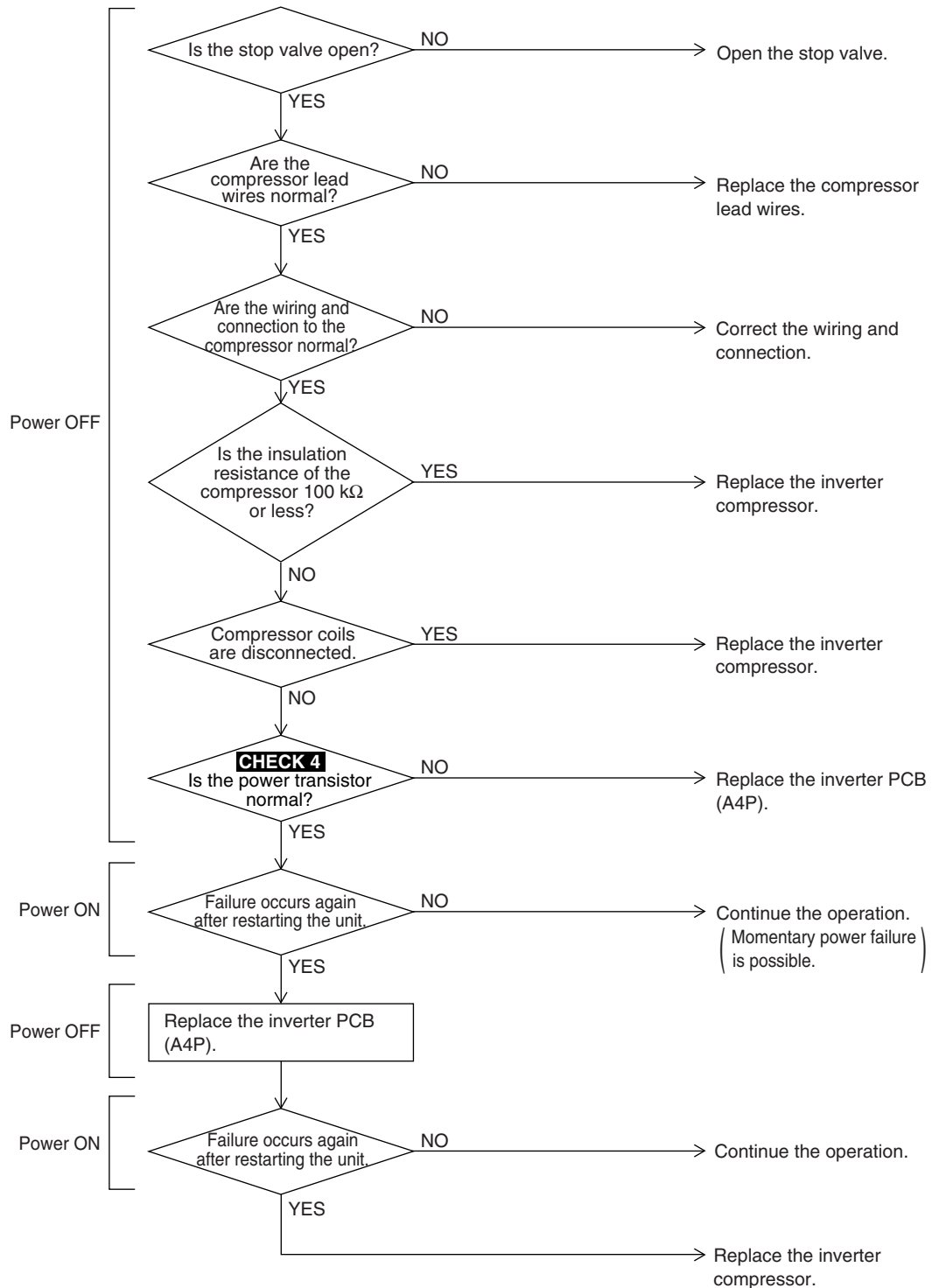

CHECK 4 Refer to P.182

2.23 Overcurrent Abnormal of Inverter Compressor

Remote Controller Display	
Applicable Models	RQYQ-PY1B
Method of Error Detection	Error is detected from the current flowing in the power transistor.
Error Decision Conditions	When the inverter secondary current value is below. (1) 33.5A and over continues for 5 seconds. (2) 27.6A and over continues for 260 seconds.
Supposed Causes	<ul style="list-style-type: none"> ■ Compressor overload ■ Compressor coil disconnected ■ Defective wiring to the compressor ■ Defective inverter PCB

Troubleshooting

Output current check



Caution Be sure to turn off power switch before connect or disconnect connector, or parts damage may be occurred.

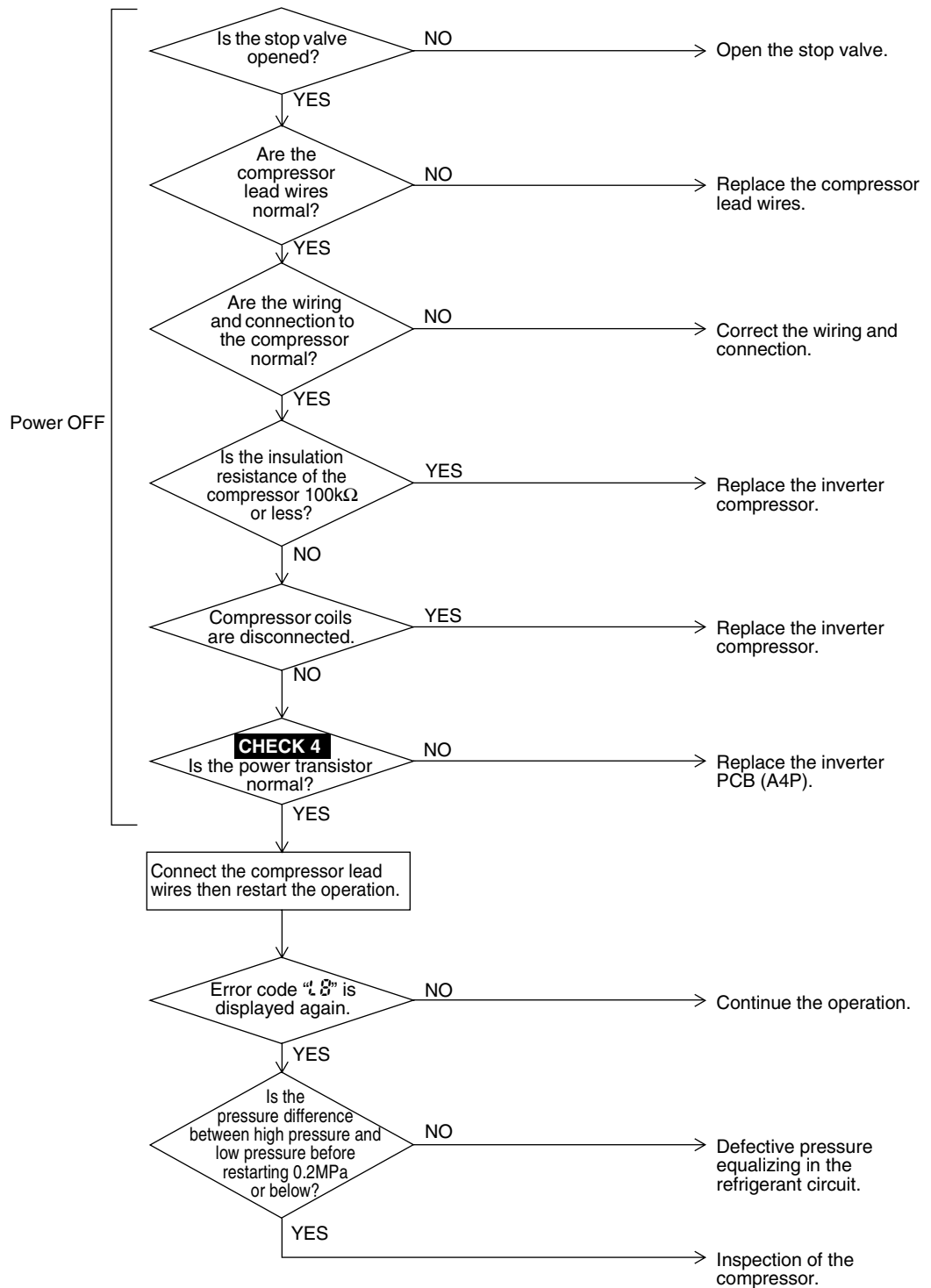

CHECK 4 Refer to P.182

2.24 Inverter Compressor Starting Abnormality

Remote
Controller
Display

U9

Applicable
Models

RQYQ-PY1B

Method of Error
Detection

Error is detected based on the signal waveform of the compressor.

Error Decision
Conditions

Starting the compressor does not complete.

Supposed
Causes

- Stop valve is not opened
- Defective compressor
- Wiring connection error to the compressor
- Large pressure difference before startup the compressor
- Defective inverter PCB

Troubleshooting



Caution

Be sure to turn off power switch before connect or disconnect connector, or parts damage may be occurred.

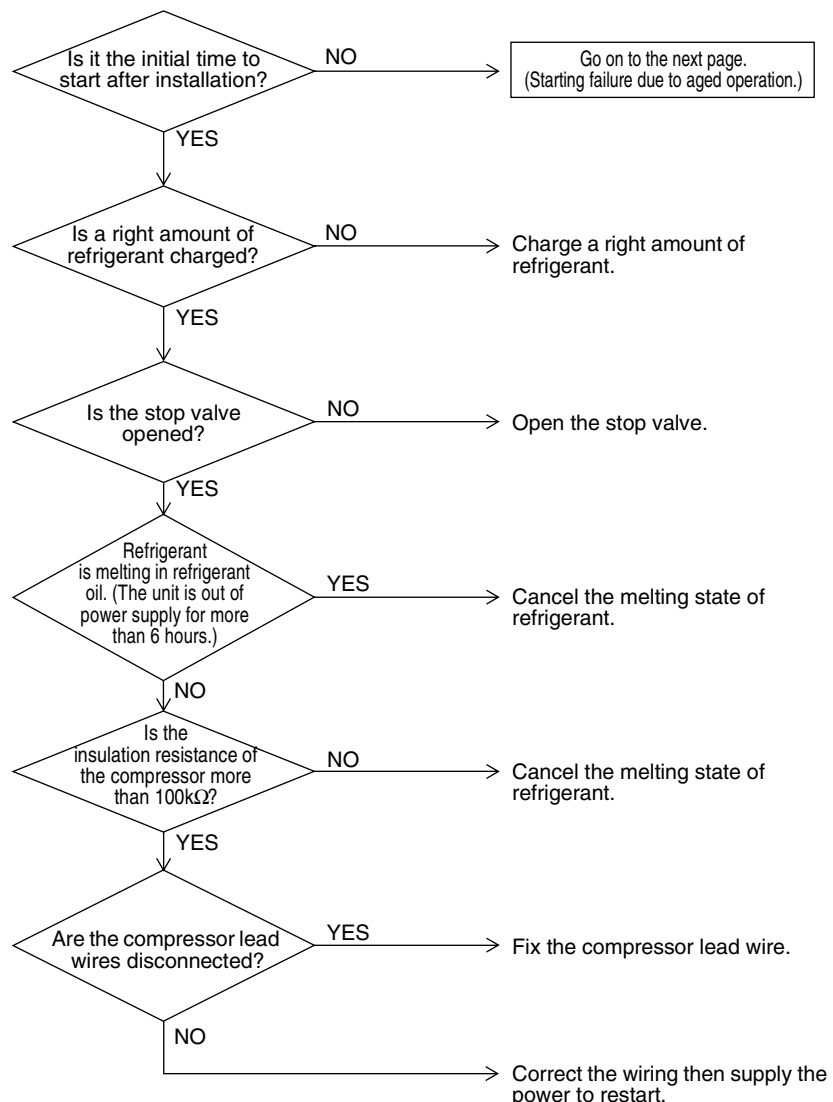

Troubleshooting

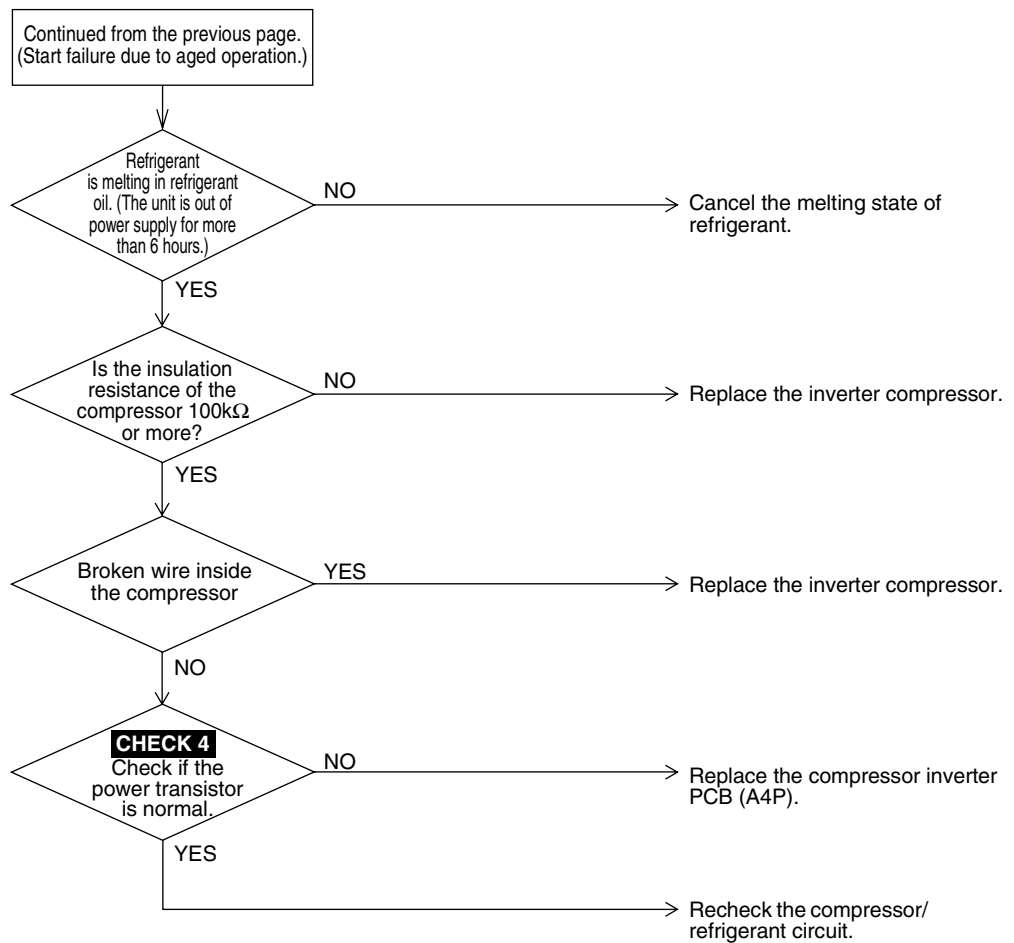

CHECK 4 Refer to P.182

2.25 Transmission System Error (between Inverter and Main PCB)

Remote Controller Display	U ₁
Applicable Models	RQYQ-PY1B
Method of Error Detection	Check the communication state between inverter PCB and main PCB by micro-computer.
Error Decision Conditions	When the transmission is not carried out in a specified period of time or longer.
Supposed Causes	<ul style="list-style-type: none"> ■ Incorrect transmission wiring between the inverter PCB and outdoor unit main PCB ■ Defective outdoor unit main PCB (transmission section) ■ Defective inverter PCB ■ Defective noise filter ■ External factor (noise etc.) ■ Defective inverter compressor ■ Defective fan motor

Troubleshooting

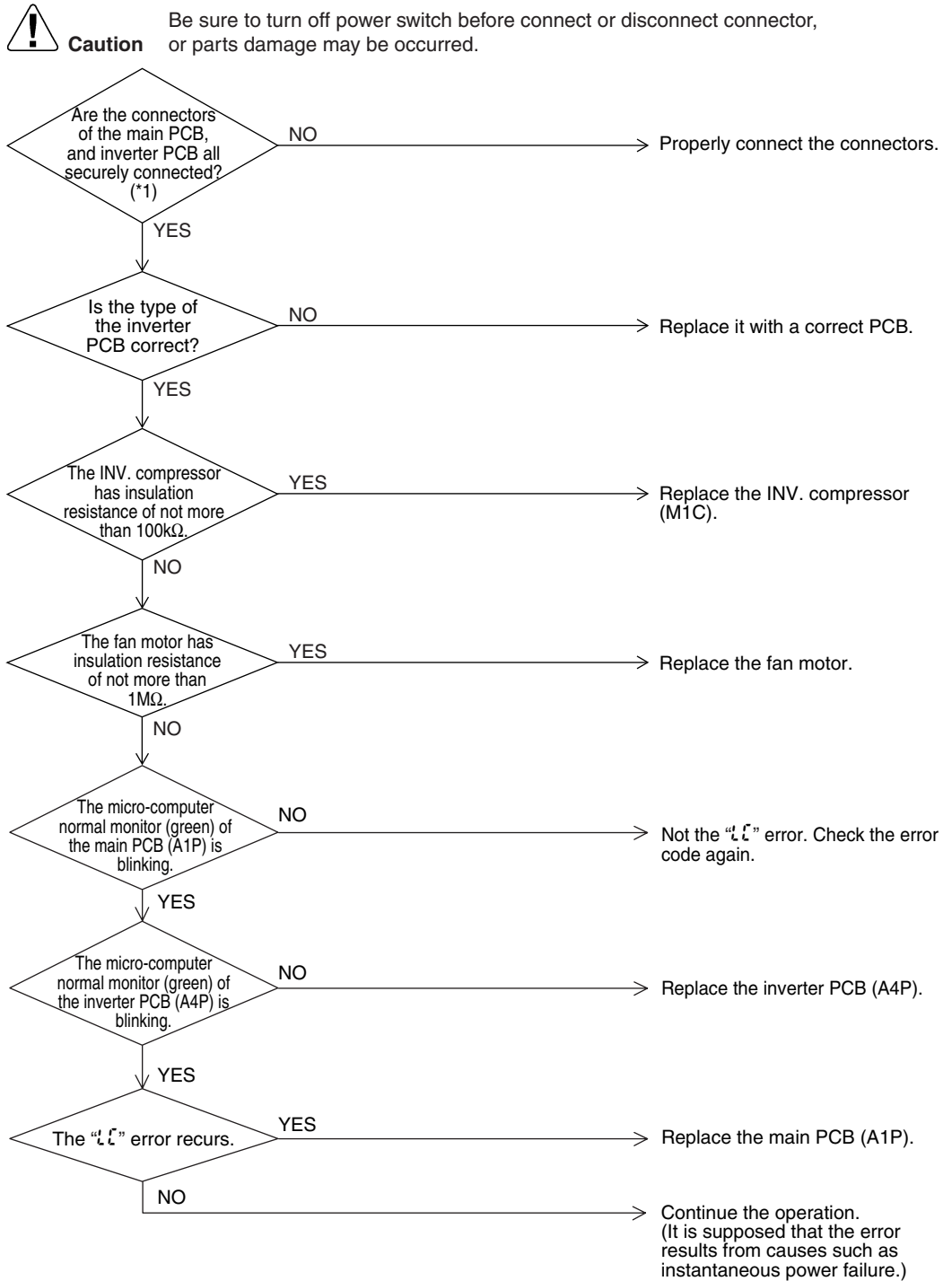

Note:

*1. Disconnect the connector once, then reconnect it and check that it is securely connected.

2.26 Inverter Over-Ripple Protection

Remote Controller Display	P I
Applicable Models	RQYQ-PY1B
Method of Error Detection	Imbalance in supply voltage is detected in PCB.
Error Decision Conditions	When the amplitude of the ripple exceeding 6V is detected. Error is not decided while the unit operation is continued. “P I” will be displayed by pressing the inspection button.
Supposed Causes	<ul style="list-style-type: none"> ■ Open phase ■ Voltage imbalance between phases ■ Defective main circuit capacitor ■ Defective inverter PCB ■ Defective K2M relay in inverter PCB ■ Improper main circuit wiring

Troubleshooting



Caution

Be sure to turn off power switch before connect or disconnect connector, or parts damage may be occurred.

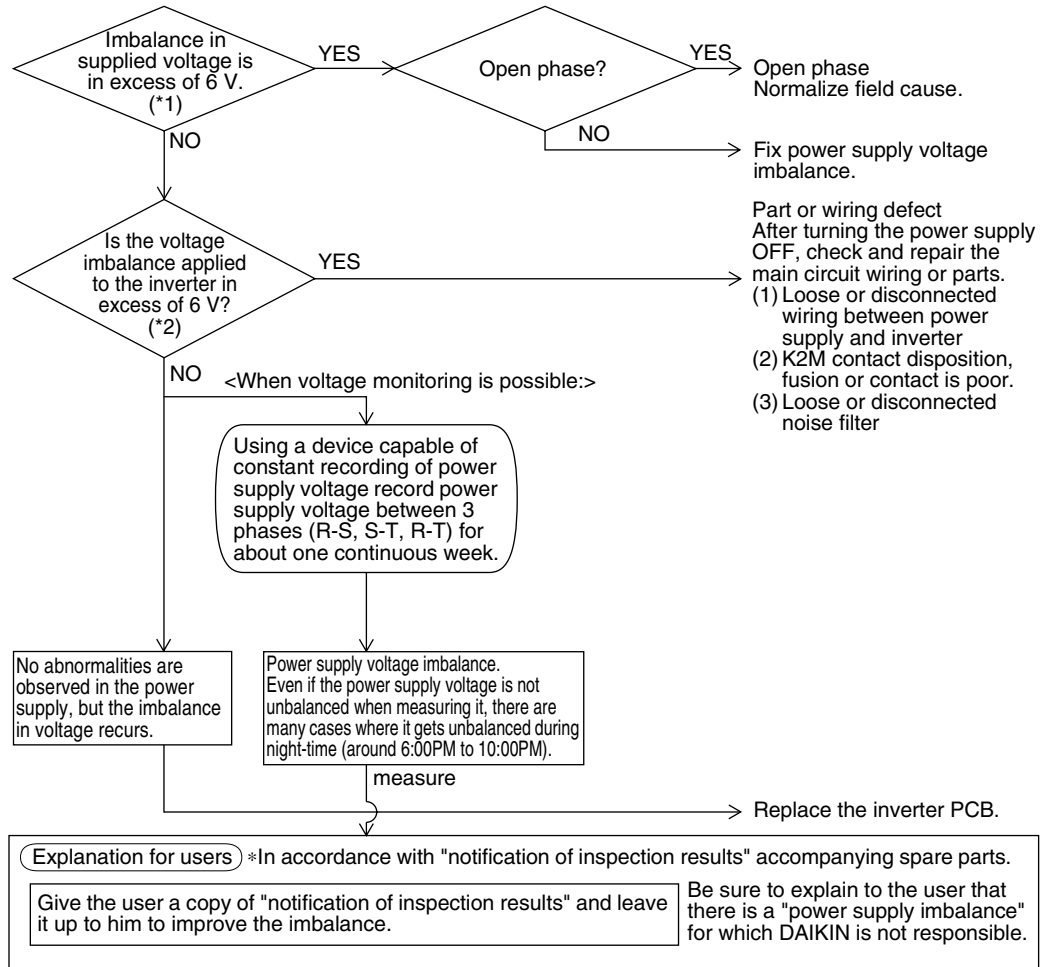

Note:

*1. Measure voltage at the X1M power supply terminal block.

*2. Measure voltage at terminals R, S and T of the diode module inside the inverter PCB while the compressor is running.

2.27 Inverter Radiation Fin Temperature Abnormality

Remote Controller Display	P4
Applicable Models	RQYQ-PY1B
Method of Error Detection	Resistance of radiation fin thermistor is detected during the compressor stops.
Error Decision Conditions	When the resistance value of thermistor becomes a value equivalent to open or short circuited status. ★ Error is not decided while the unit operation is continued. "P4" will be displayed by pressing the inspection button.
Supposed Causes	<ul style="list-style-type: none"> ■ Defective radiation fin thermistor ■ Defective inverter PCB ■ Defective inverter compressor ■ Defective fan motor

Troubleshooting

Caution

Be sure to turn off power switch before connect or disconnect connector, or parts damage may be occurred.

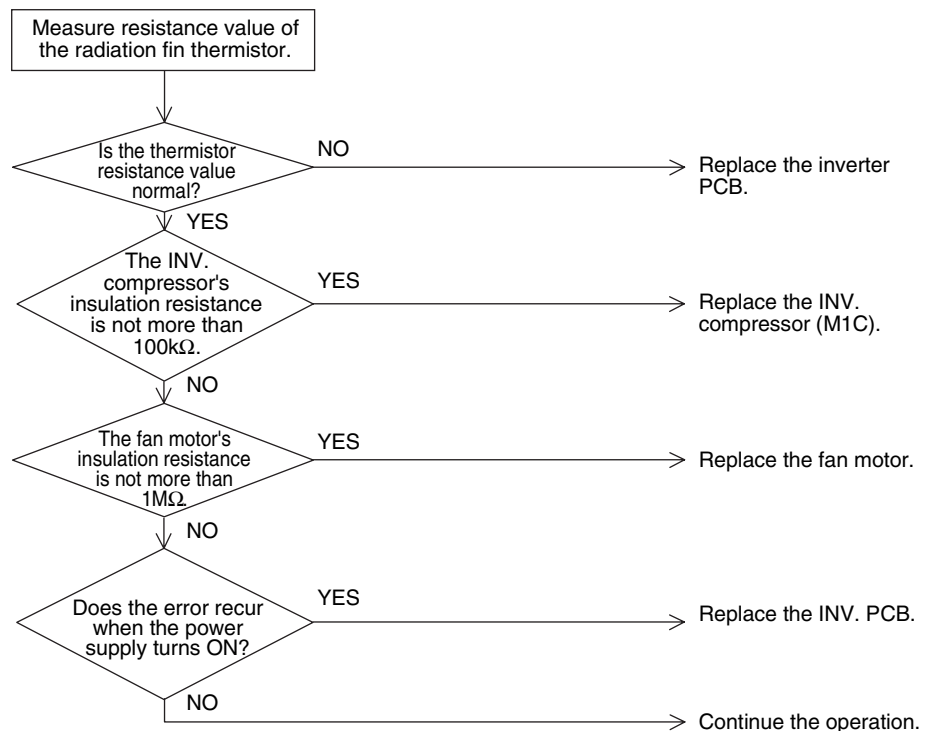

2.28 Field Setting Abnormality after Replacing Main PCB or Combination Error of PCB

Remote Controller Display	PU
Applicable Models	RQYQ-PY1B
Method of Error Detection	This error is detected according to communications with the INV. PCB.
Error Decision Conditions	Make judgement according to communication data on whether or not the type of the INV. PCB is correct.
Supposed Causes	<ul style="list-style-type: none"> ■ Mis-matching of type of PCB ■ Defective (or no) field setting after replacing main PCB

Troubleshooting



Caution Be sure to turn off power switch before connect or disconnect connector, or parts damage may be occurred.

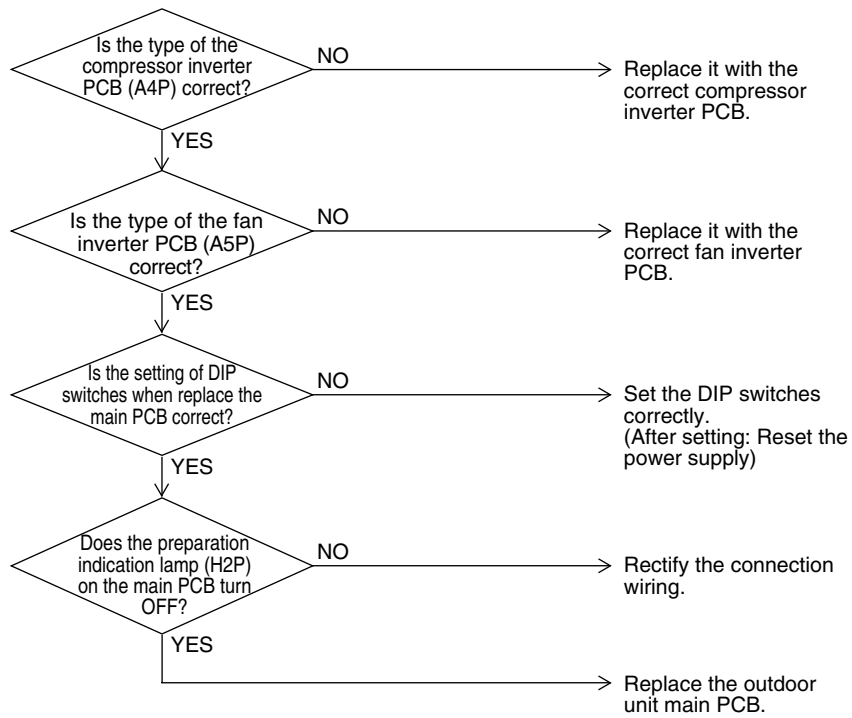

2.29 Refrigerant Shortage

Remote Controller Display	
Applicable Models	RQYQ-PY1B
Method of Error Detection	Detect refrigerant shortage based on the temperature difference between low pressure or suction pipe and heat exchanger.
Error Decision Conditions	<p>[In cooling mode] Low pressure becomes 0.1MPa or less.</p> <p>[In heating mode] The degree of superheat of suction gas becomes 20 degrees or more. $SH = Ts1 - Te$ $Ts1$: Temperature detected by suction pipe thermistor Te: Low pressure equivalent saturation temperature ★Error is not determined. The unit continues operation.</p>
Supposed Causes	<ul style="list-style-type: none"> ■ Refrigerant shortage or refrigerant clogging (wrong piping) ■ Defective thermistor (R8T, R9T) ■ Defective low pressure sensor ■ Defective outdoor unit PCB (A1P)

Troubleshooting



Caution Be sure to turn off power switch before connect or disconnect connector, or parts damage may be occurred.

In cooling

- ① Mount a pressure gauge at the service port on the low pressure side.
- ② Reset the operation using the remote controller then restart.

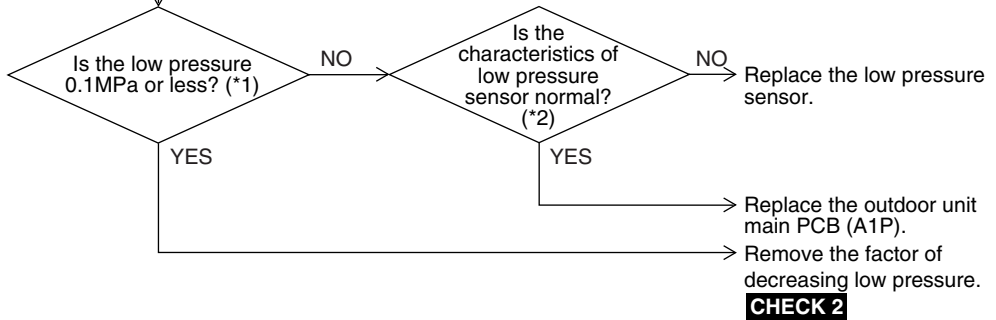

In heating

Reset the operation using the remote controller then restart.

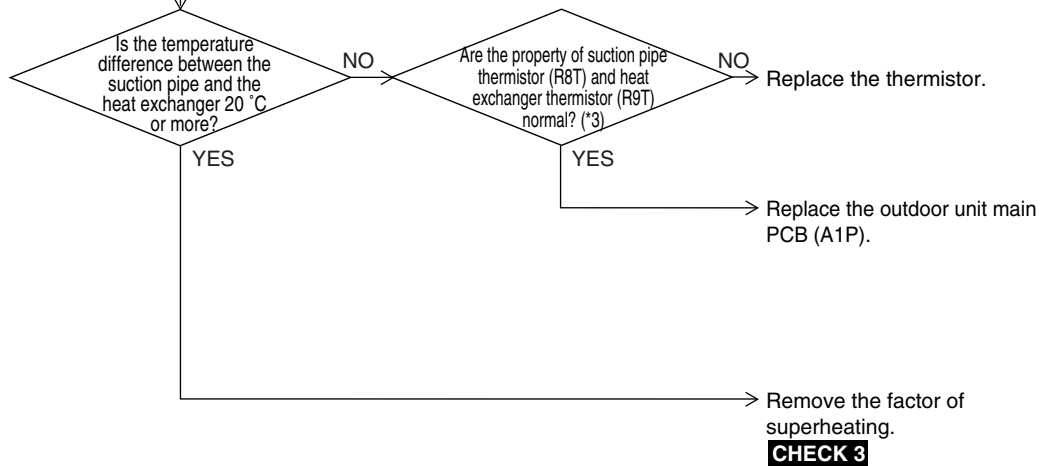

Note:

- *1. Check the low pressure value by using pressure gauge in operation.
- *2. Compare the actual measurement value by pressure sensor with the value by the pressure gauge.
- *3. Compare the thermistor resistance value with the value on the surface thermometer.



CHECK 2 Refer to P.180



CHECK 3 Refer to P.181

2.30 Reverse Phase, Open Phase

Remote
Controller
Display



Applicable
Models

RQYQ-PY1B

Method of Error
Detection

The phase of each phase are detected by reverse phase detection circuit and right phase or reverse phase are judged.

Error Decision
Conditions

When a power supply is reverse phase, or T phase is open phase.

Supposed
Causes

- Power supply reverse phase
- T phase open phase
- Defective outdoor unit PCB (A1P)

Troubleshooting



Caution

Be sure to turn off power switch before connect or disconnect connector, or parts damage may be occurred.

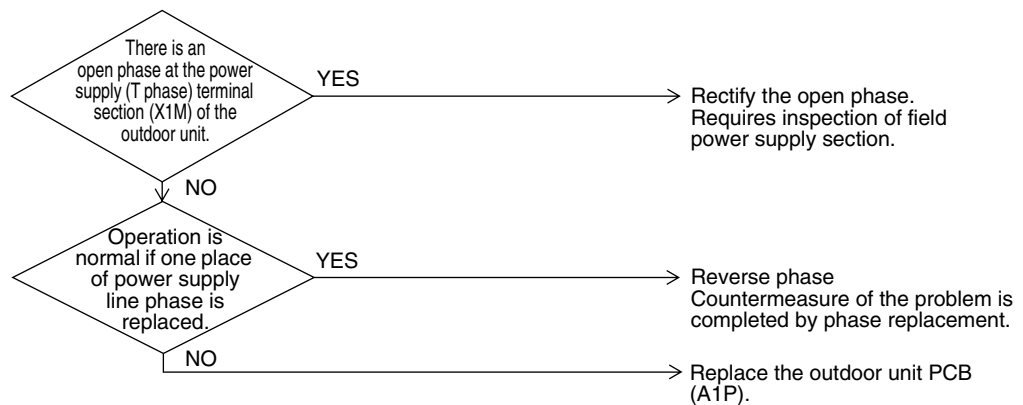

2.31 Power Supply Insufficient or Instantaneous Failure

Remote Controller Display	
Applicable Models	RQYQ-PY1B
Method of Error Detection	Detection of voltage of main circuit capacitor built in the inverter PCB and power supply voltage.
Error Decision Conditions	When the voltage aforementioned is not less than 190V.
Supposed Causes	<ul style="list-style-type: none"> ■ Power supply insufficient ■ Instantaneous power failure ■ Open phase ■ Defective inverter PCB ■ Defective outdoor service monitor PCB ■ Defective compressor ■ Defective main circuit wiring ■ Defective fan motor ■ Defective connection of signal cable

Troubleshooting



Caution

Be sure to turn off power switch before connect or disconnect connector, or parts damage may be occurred.

Check the condition of the power supply.
 ① Check if power supply voltage is 380 to 415V.
 ② Check if there is open phase or wrong wiring.
 ③ Check if power supply voltage side unbalance is with in 6V.

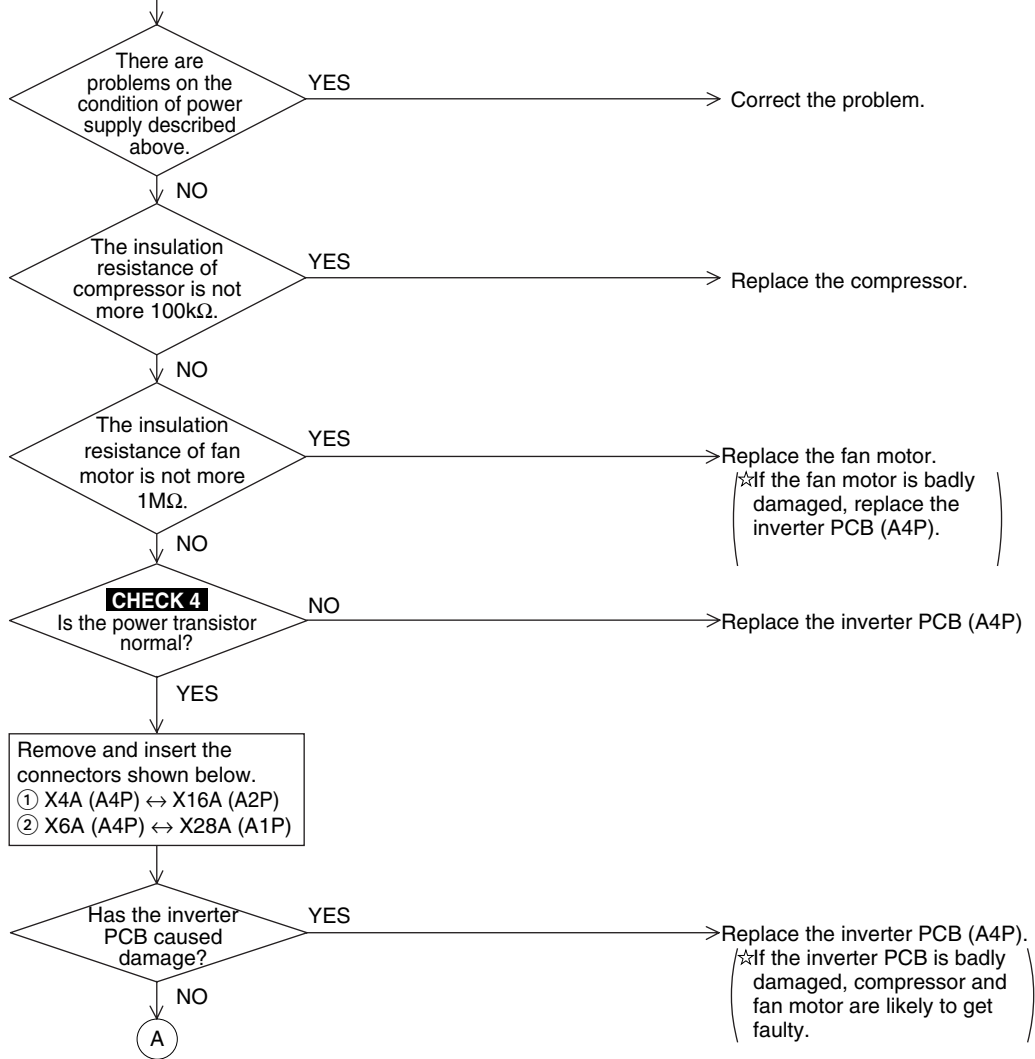

Troubleshooting

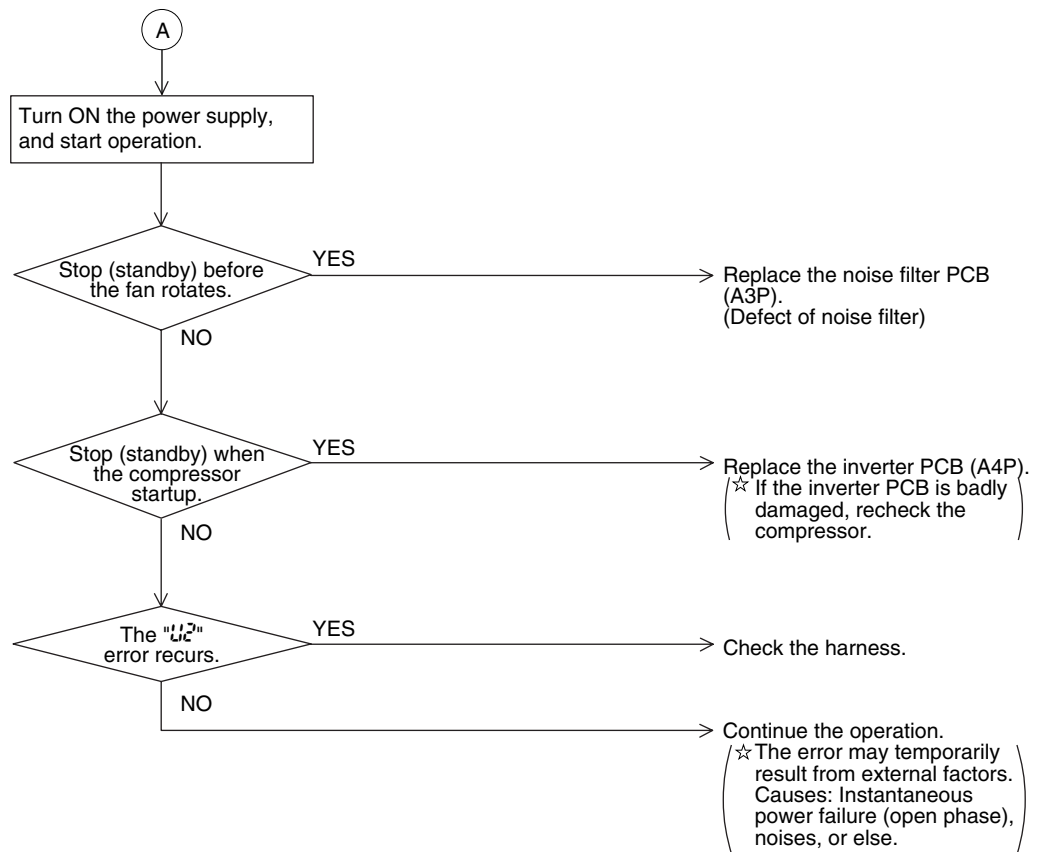

CHECK 4 Refer to P.182

2.32 Check Operation is not Executed

Remote Controller Display	U3
Applicable Models	RQYQ-PY1B
Method of Error Detection	Check operation is executed or not
Error Decision Conditions	Error is decided when the unit starts operation without check operation.
Supposed Causes	<ul style="list-style-type: none"> ■ Check operation is not executed.
Troubleshooting	<p> Caution Be sure to turn off power switch before connect or disconnect connector, or parts damage may be occurred.</p> <pre> graph TD Q{Has the check operation performed on outdoor unit PCB?} Q -- NO --> A[Press and hold BS4 on the outdoor unit main PCB for 5 seconds or more to conduct a check operation.] Q -- YES --> B[Performs the check operation again and completes the check operation.] </pre>

2.33 Transmission Error (between Indoor and Outdoor Units)

Remote Controller Display	
Applicable Models	All indoor unit models RQYQ-PY1B
Method of Error Detection	The error is generated when the micro-computer detects that the transmission between the indoor and outdoor unit is not normal.
Error Decision Conditions	When transmission is not carried out normally for a certain amount of time
Supposed Causes	<ul style="list-style-type: none"> ■ Indoor to outdoor, outdoor to outdoor transmission wiring F1, F2 disconnection, short circuit or wrong wiring ■ Outdoor unit power supply is OFF ■ System address does not match ■ Defective outdoor unit main PCB (A1P) ■ Defective indoor unit PCB

Troubleshooting



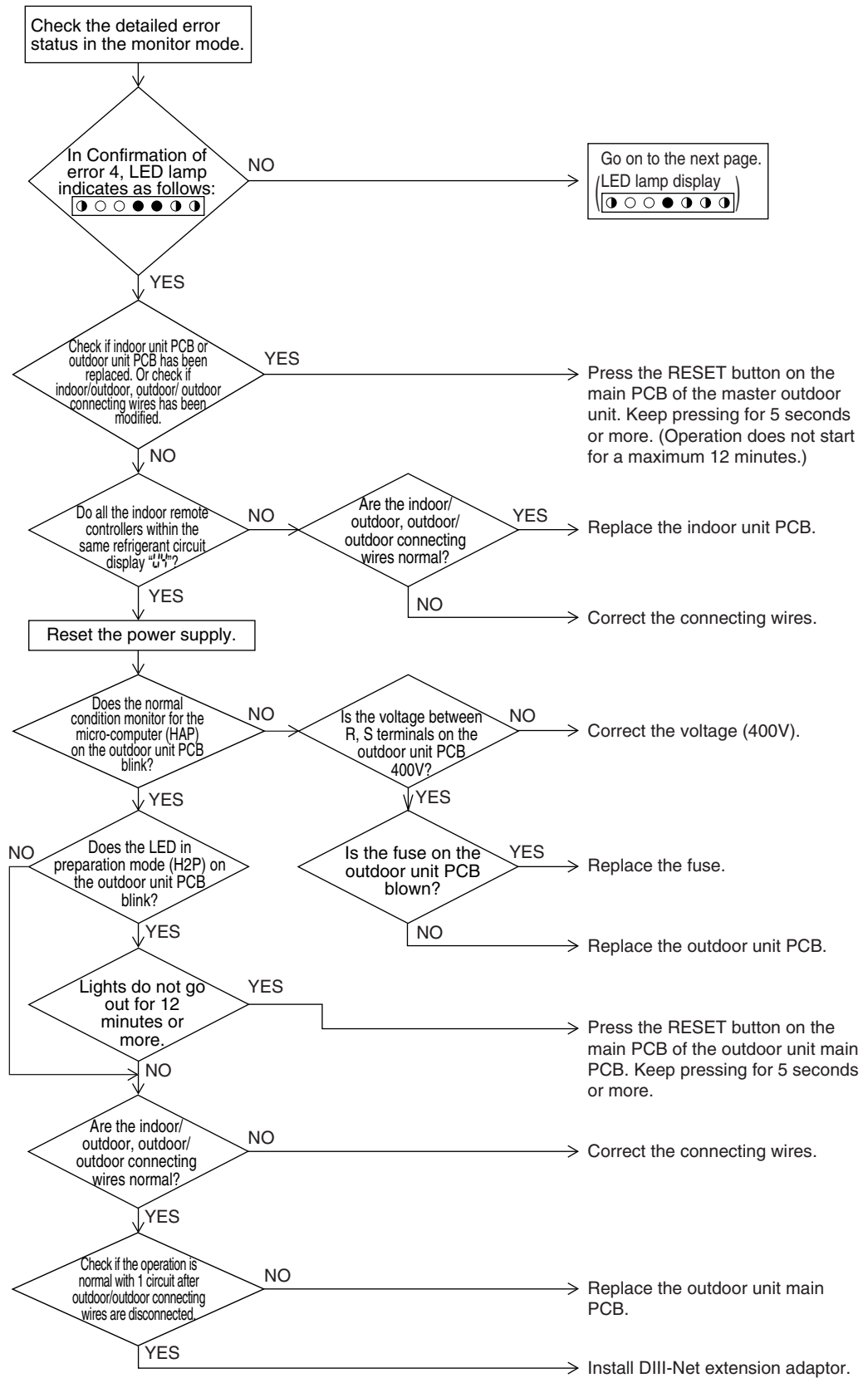

Caution

Be sure to turn off power switch before connect or disconnect connector, or parts damage may be occurred.



Troubleshooting

 **Caution** Be sure to turn off power switch before connect or disconnect connector, or parts damage may be occurred.

Continued from the previous page
 In Confirmation of error 4,
 LED lamp indicates as follows:

Start operation of all the indoor units.

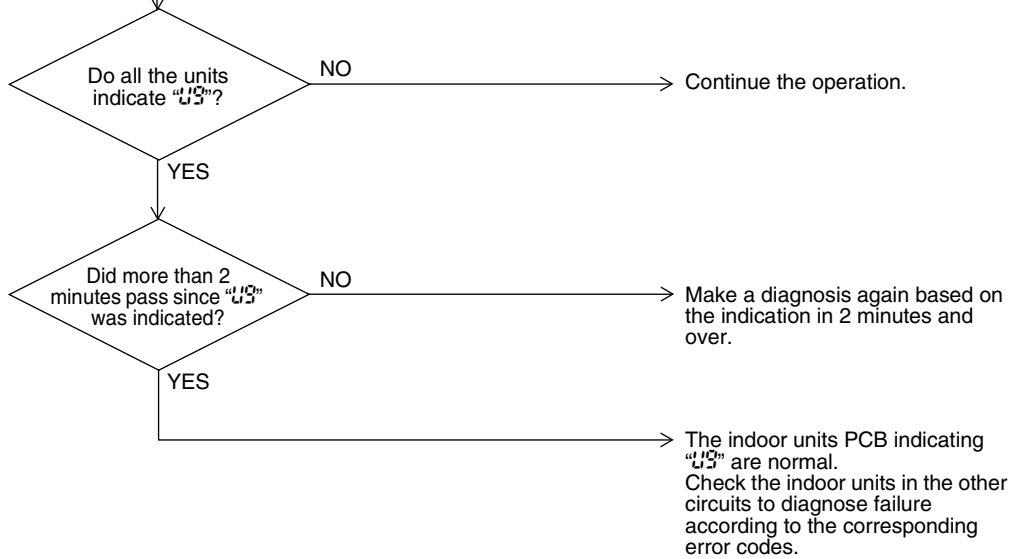

2.34 Transmission Error (between Remote Controller and Indoor Unit)

Remote
Controller
Display

05

Applicable
Models

All indoor unit models

Method of Error
Detection

Micro-computer checks if transmission between indoor unit and remote controller is normal.

Error Decision
Conditions

Normal transmission does not continue for specified period.

Supposed
Causes

- Transmission error between indoor unit and remote controller
- Connection of two main remote controllers (when using 2 remote controllers)
- Defective indoor unit PCB
- Defective remote controller PCB
- Transmission error caused by noise

Troubleshooting



Caution

Be sure to turn off power switch before connect or disconnect connector, or parts damage may be occurred.

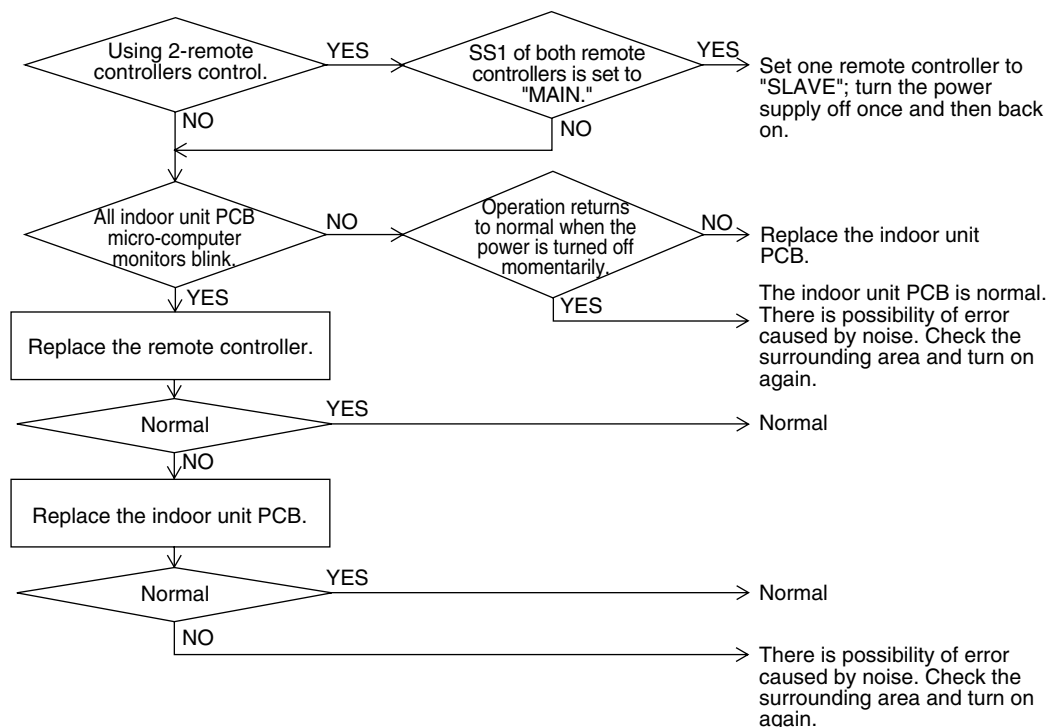

2.35 Transmission Error (Across Outdoor Units)

Remote Controller Display	U7
Applicable Models	RQYQ-PY1B
Method of Error Detection	Micro-computer checks if transmission between outdoor units is normal.
Error Decision Conditions	When transmission is not carried out normally for a certain amount of time
Supposed Causes	<ul style="list-style-type: none"> ■ Connection error in connecting wires between outdoor unit and external control adaptor for outdoor unit ■ Connection error in connecting wires across outdoor units ■ Setting error in switching cool/heat ■ Unified address setting error for cool/heat (external control adaptor for outdoor unit) ■ Defective outdoor unit PCB (A1P) ■ Defective external control adaptor for outdoor unit

Troubleshooting



Caution

Be sure to turn off power switch before connect or disconnect connector, or parts damage may be occurred.

Check the LED lamps for "Confirmation of error 3" corresponding to the error code "U1" and for Confirmation of error 4 in the monitor mode.



Troubleshooting

 **Caution** Be sure to turn off power switch before connect or disconnect connector, or parts damage may be occurred.

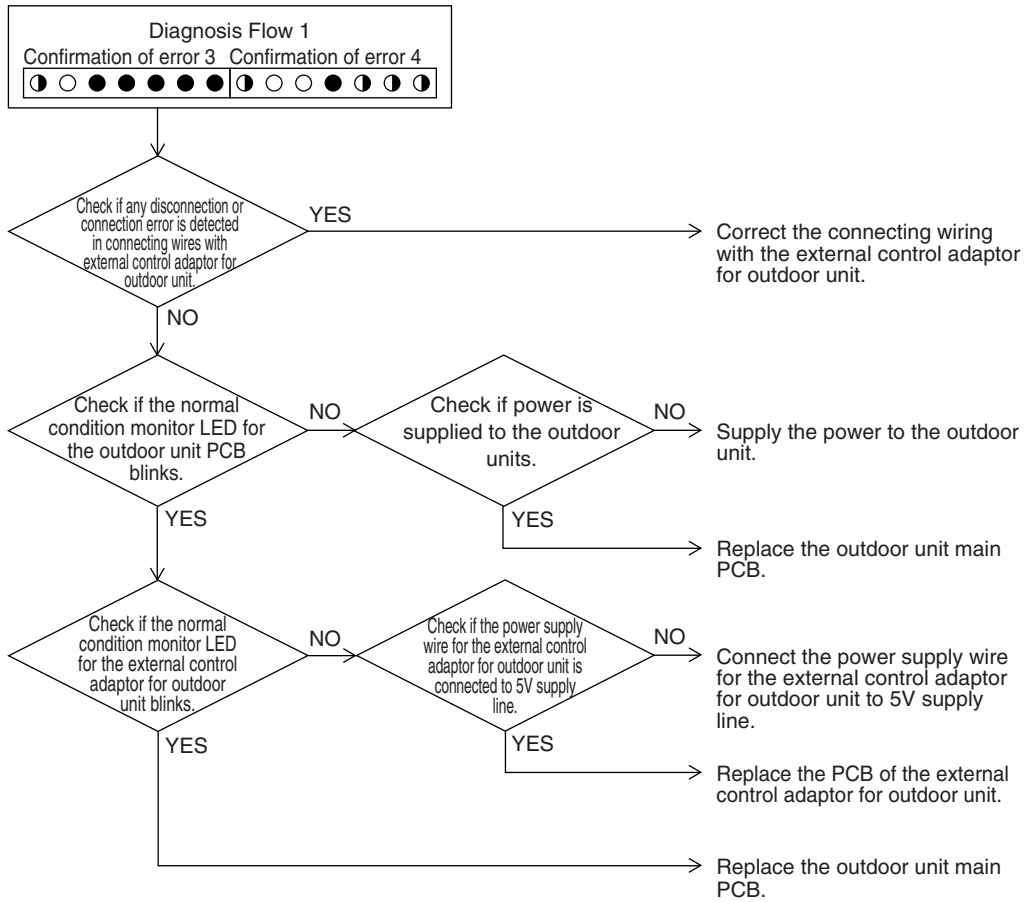

Troubleshooting

 **Caution** Be sure to turn off power switch before connect or disconnect connector, or parts damage may be occurred.

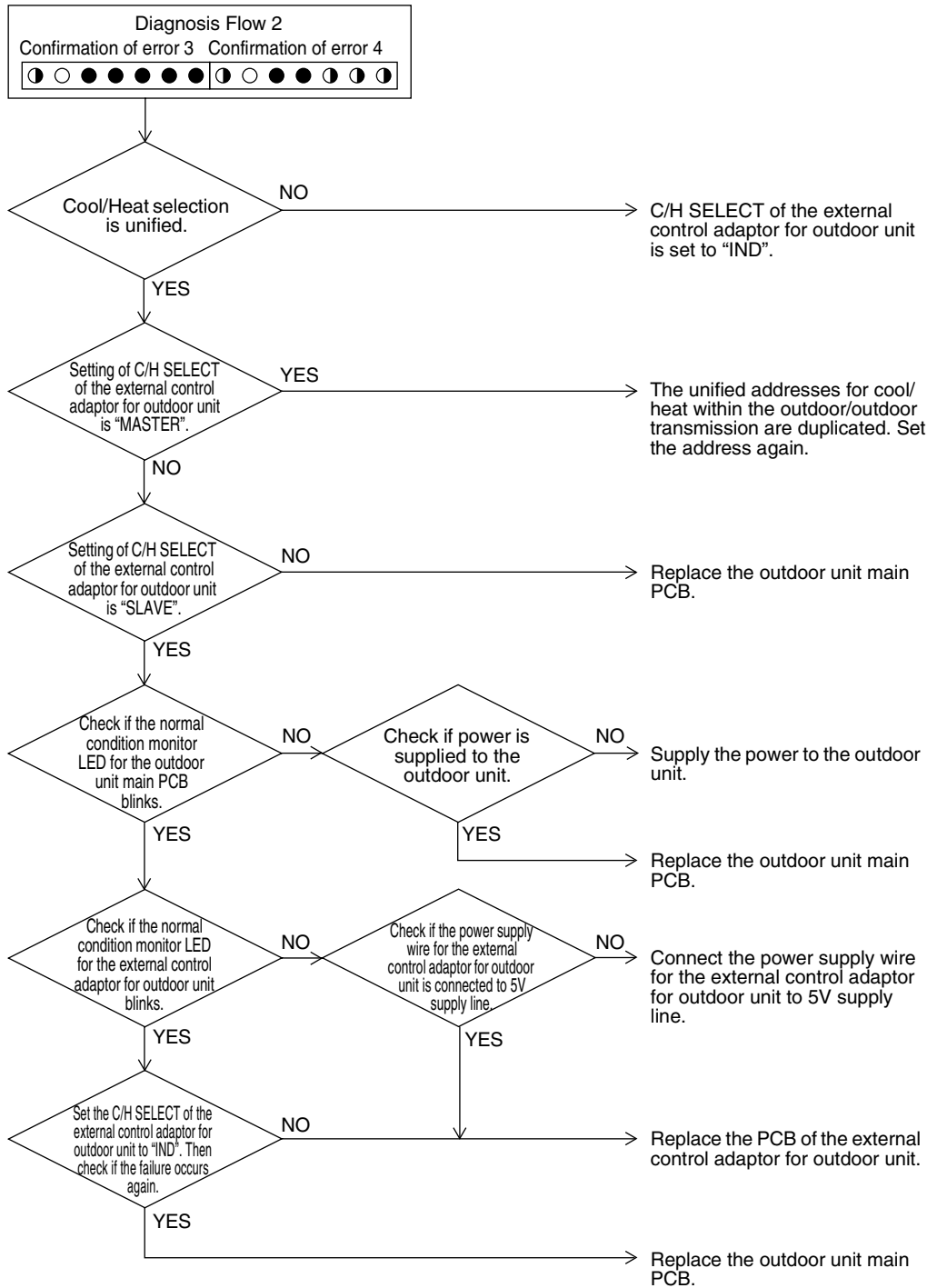

Troubleshooting

 **Caution** Be sure to turn off power switch before connect or disconnect connector, or parts damage may be occurred.

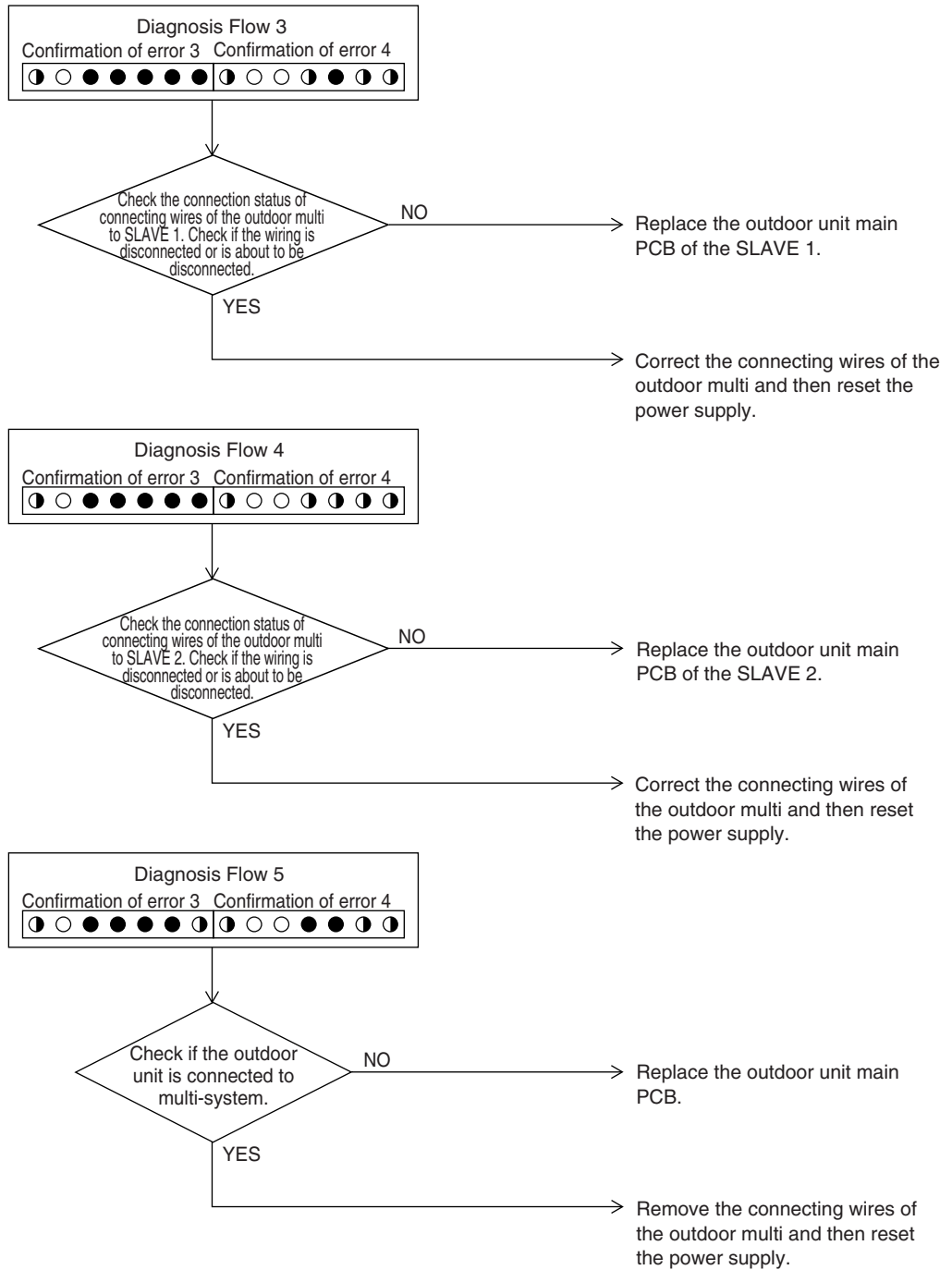

Troubleshooting

 **Caution** Be sure to turn off power switch before connect or disconnect connector, or parts damage may be occurred.

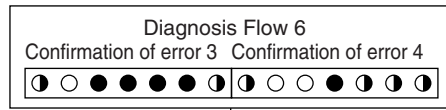

Check the connection status of one of the connecting wires of outdoor multi. Check if the wiring is broken or disconnected.

NO

→ Replace the outdoor unit main PCB.

YES

→ Correct the connecting wires of the outdoor multi and then reset the power supply.

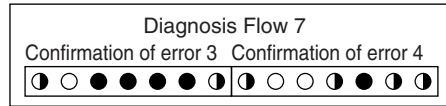

In the connection status of the outdoor multi, check if more than 4 outdoor units are connected.

NO

→ Replace the outdoor unit main PCB.

YES

→ Correct the connecting wires of the outdoor multi and then reset the power supply.

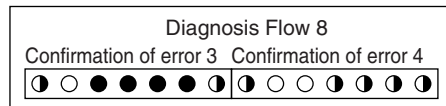

Check the connection status of the connecting wires of outdoor multi. Check if the wiring has any connection error or broken, or is about to be disconnected.

NO

→ Replace the outdoor unit main PCB.

YES

→ Correct the connecting wires of the outdoor multi and then reset the power supply.

2.36 Transmission Error (between Main and Sub Remote Controllers)

Remote Controller Display

00

Applicable Models

All indoor unit models

Method of Error Detection

In case of controlling with 2-remote controller, check the system using micro-computer if signal transmission between indoor unit and remote controller (main and sub) is normal.

Error Decision Conditions

Normal transmission does not continue for a certain amount of time.

Supposed Causes

- Transmission error between main and sub remote controller
- Connection among sub remote controllers
- Defective remote controller PCB

Troubleshooting



Caution

Be sure to turn off power switch before connect or disconnect connector, or parts damage may be occurred.

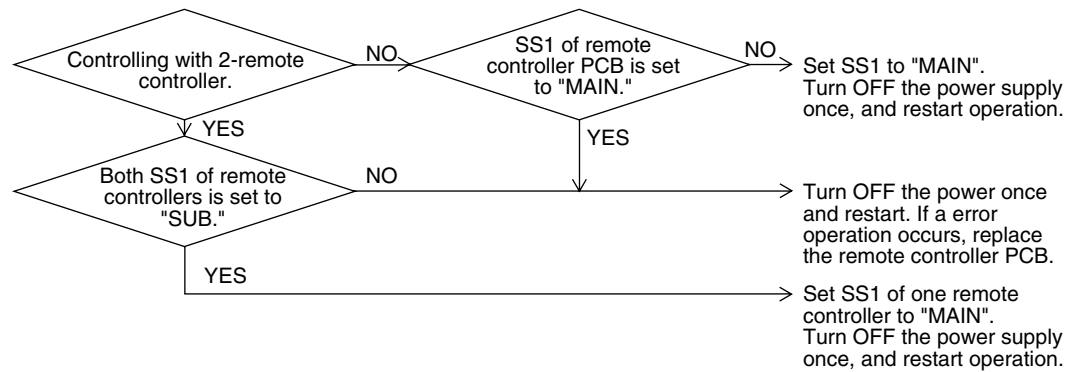

2.37 Transmission Error (between Indoor and Outdoor Units in the Same System)

Remote
Controller
Display

U3

Applicable
Models

All models of indoor unit
RQYQ-PY1B

Method of Error
Detection

Detect error signal for the other indoor units within the circuit by outside unit PCB.

Error Decision
Conditions

When the error decision is made on any other indoor unit within the system concerned.

Supposed
Causes

- Transmission error within or outside of other system
- Defective electronic expansion valve in indoor unit of other system
- Defective PCB of indoor unit in other system
- Improper connection of transmission wiring between indoor and outdoor unit

Troubleshooting



Caution Be sure to turn off power switch before connect or disconnect connector, or parts damage may be occurred.

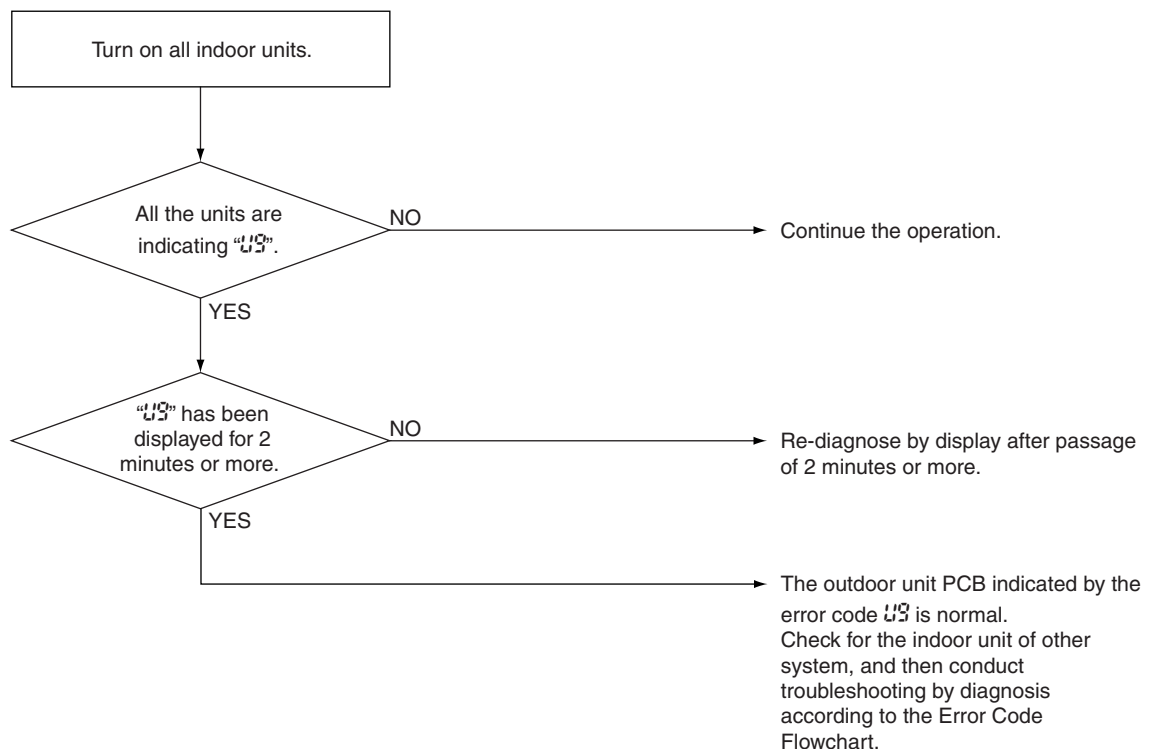

2.38 Improper Combination of Indoor and Outdoor Units, Indoor Units and Remote Controller

Remote Controller Display	
Applicable Models	All indoor unit models RQYQ-PY1B
Method of Error Detection	A difference occurs in data by the refrigerant type between indoor and outdoor units. The number of indoor units is out of the allowable range.
Error Decision Conditions	The error decision is made as soon as either of the abnormalities aforementioned is detected.
Supposed Causes	<ul style="list-style-type: none"> ■ Excess of connected indoor units ■ Defective outdoor unit PCB (A1P) ■ Mismatching of the refrigerant type of indoor and outdoor unit. ■ Setting of outdoor unit PCB was not conducted after replacing to spare PCB.

Troubleshooting



Caution

Be sure to turn off power switch before connect or disconnect connector, or parts damage may be occurred.

Check the LED lamps for "Confirmation of error 3" corresponding to the error code "U3" and for Confirmation of error 4 in the monitor mode.

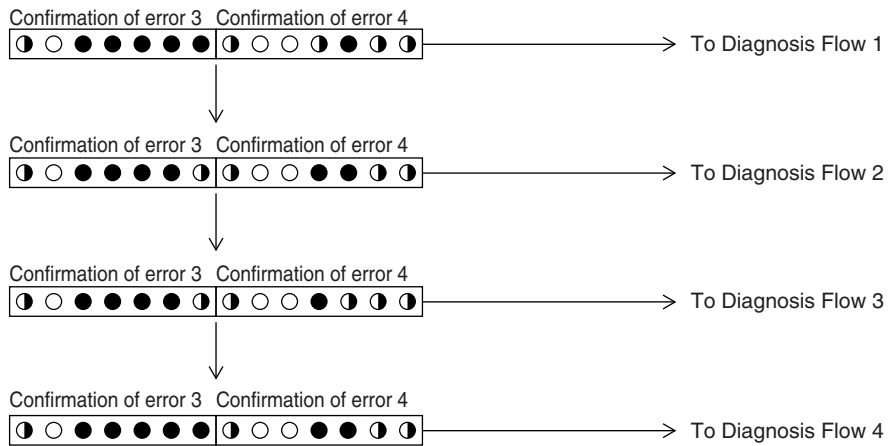

Troubleshooting

 **Caution** Be sure to turn off power switch before connect or disconnect connector, or parts damage may be occurred.

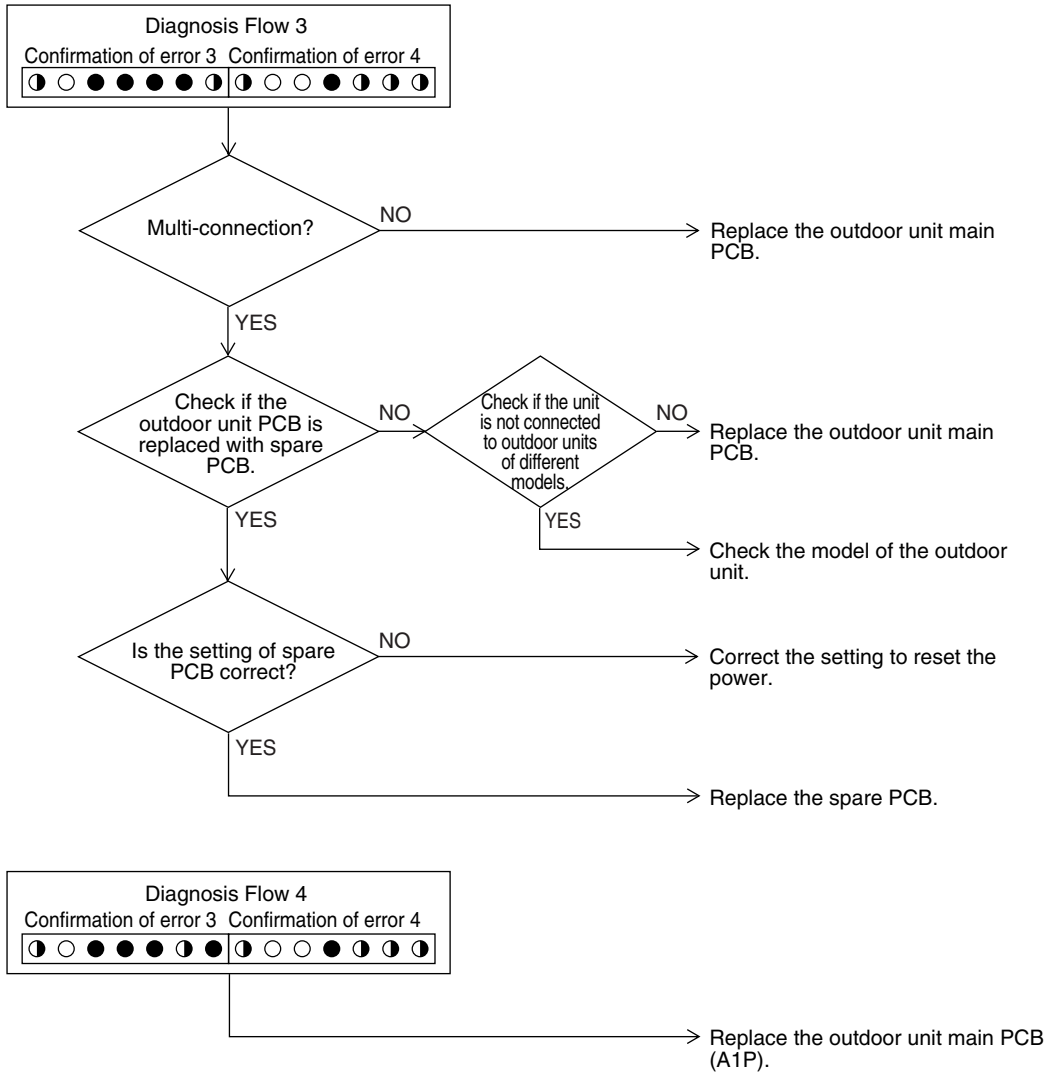

2.39 Address Duplication of Centralized Controller

Remote Controller Display	
Applicable Models	All models of indoor unit Centralized controller
Method of Error Detection	The principal indoor unit detects the same address as that of its own on any other indoor unit.
Error Decision Conditions	The error decision is made as soon as the abnormality aforementioned is detected.
Supposed Causes	<ul style="list-style-type: none"> ■ Address duplication of centralized controller ■ Defective the indoor unit PCB.
Troubleshooting	



Caution

Be sure to turn off power switch before connect or disconnect connector, or parts damage may be occurred.

The centralized address is duplicated.

→ Make setting change so that the centralized address will not be duplicated.

2.40 Transmission Error (between Centralized Controller and Indoor Unit)

Remote Controller Display	UE
Applicable Models	All models of indoor unit intelligent Touch Controller Centralized remote controller Schedule timer
Method of Error Detection	Micro-computer checks if transmission between indoor unit and centralized controller is normal.
Error Decision Conditions	When transmission is not carried out normally for a certain amount of time
Supposed Causes	<ul style="list-style-type: none"> ■ Transmission error between optional controllers for centralized control and indoor unit ■ Connector for setting main controller is disconnected. (or disconnection of connector for independent / combined use changeover switch.) ■ Failure of PCB for centralized remote controller ■ Defective indoor unit PCB

Troubleshooting



Caution

Be sure to turn off power switch before connect or disconnect connector, or parts damage may be occurred.

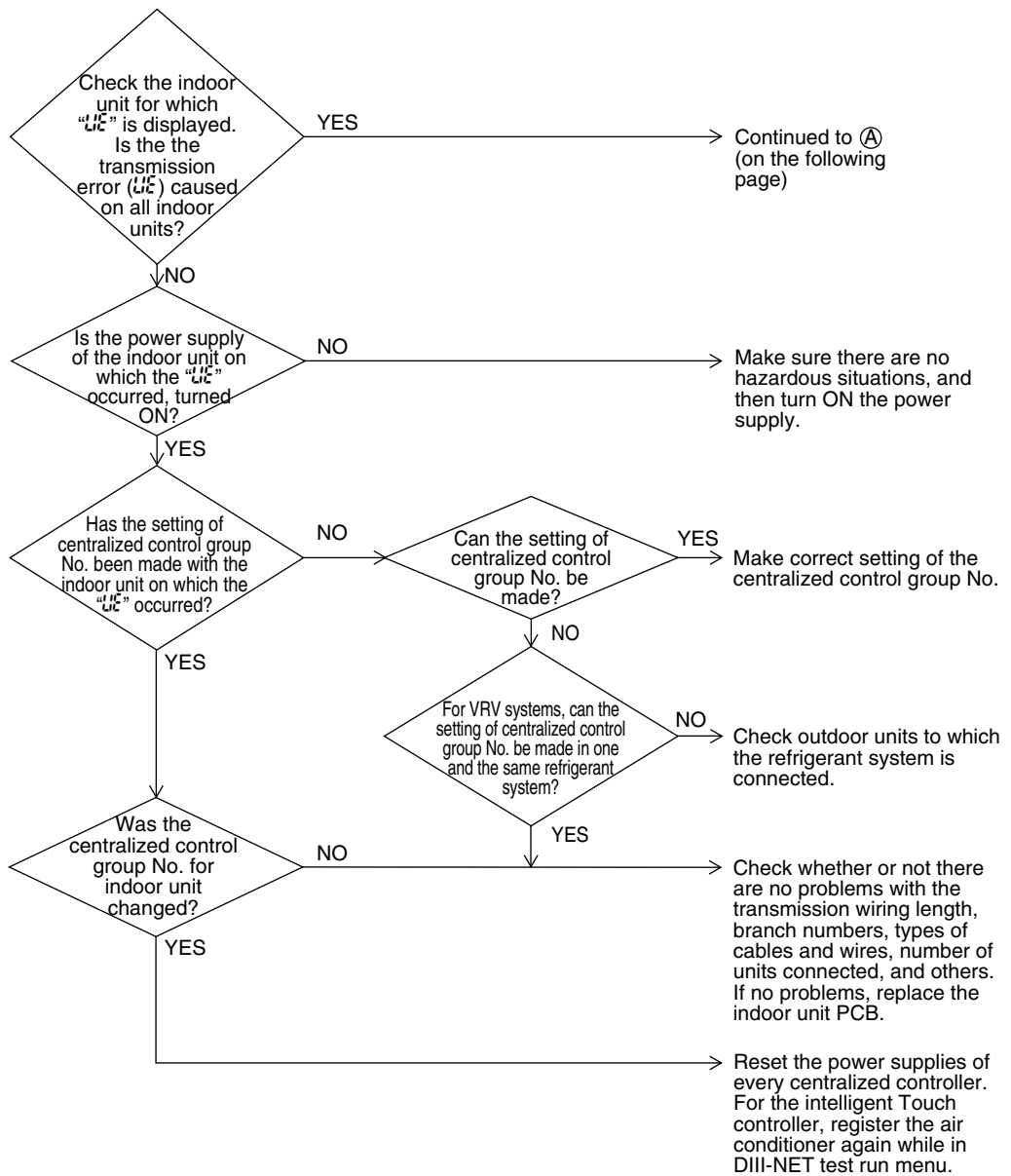

Troubleshooting

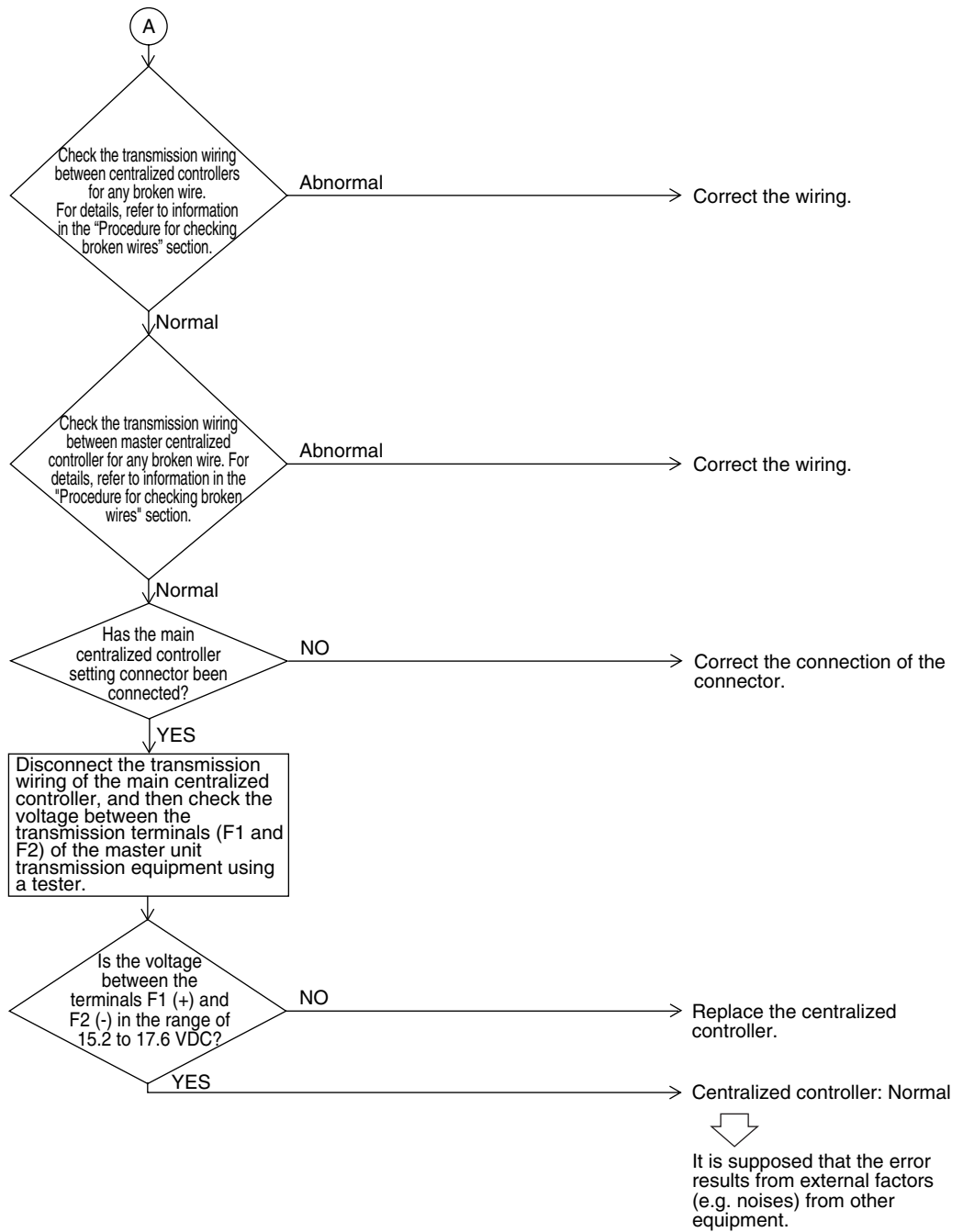

2.41 System is not Set yet

Remote Controller Display	
Applicable Models	All models of indoor unit RQYQ-PY1B
Method of Error Detection	On check operation, the number of indoor units in terms of transmission is not corresponding to that of indoor units that have made changes in temperature.
Error Decision Conditions	The error is determined as soon as the abnormality aforementioned is detected through checking the system for any erroneous connection of units on the check operation.
Supposed Causes	<ul style="list-style-type: none"> ■ Improper connection of transmission wiring between indoor-outdoor units and outdoor-outdoor units ■ Failure to execute check operation ■ Defective indoor unit PCB ■ Stop valve is not opened

Troubleshooting



Caution

Be sure to turn off power switch before connect or disconnect connector, or parts damage may be occurred.

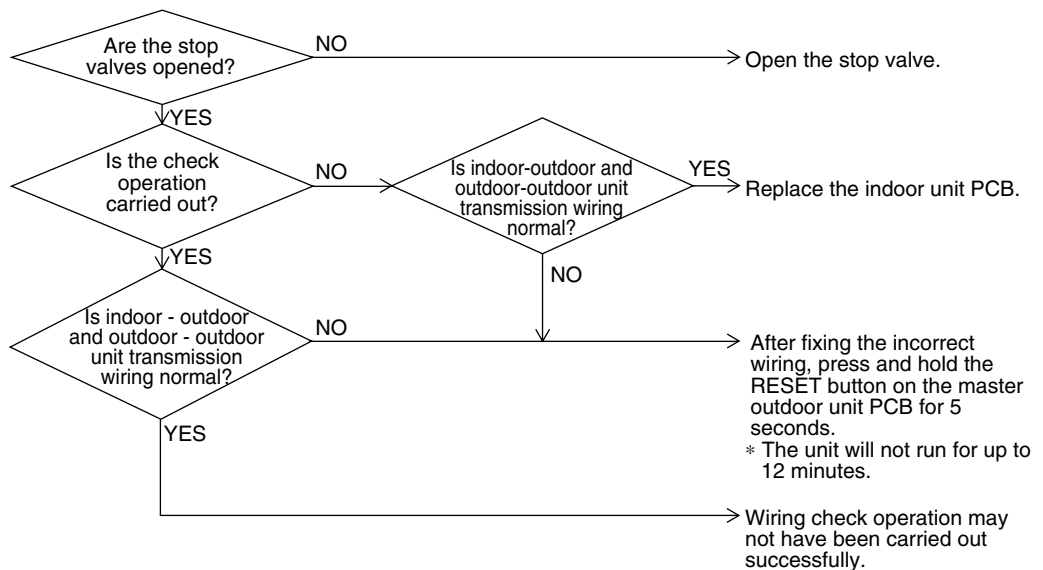

2.42 System Error, Refrigerant System Address Undefined

Remote
Controller
Display



Applicable
Models

All models of indoor unit
RQYQ-PY1B

Method of Error
Detection

Detect an indoor unit with no auto address setting.

Error Decision
Conditions

The error decision is made as soon as the abnormality aforementioned is detected.

Supposed
Causes

- Improper connection of transmission wiring between indoor-outdoor units and outdoor-outdoor units
- Defective indoor unit PCB
- Defective outdoor unit main PCB

Troubleshooting



Caution

Be sure to turn off power switch before connect or disconnect connector, or parts damage may be occurred.

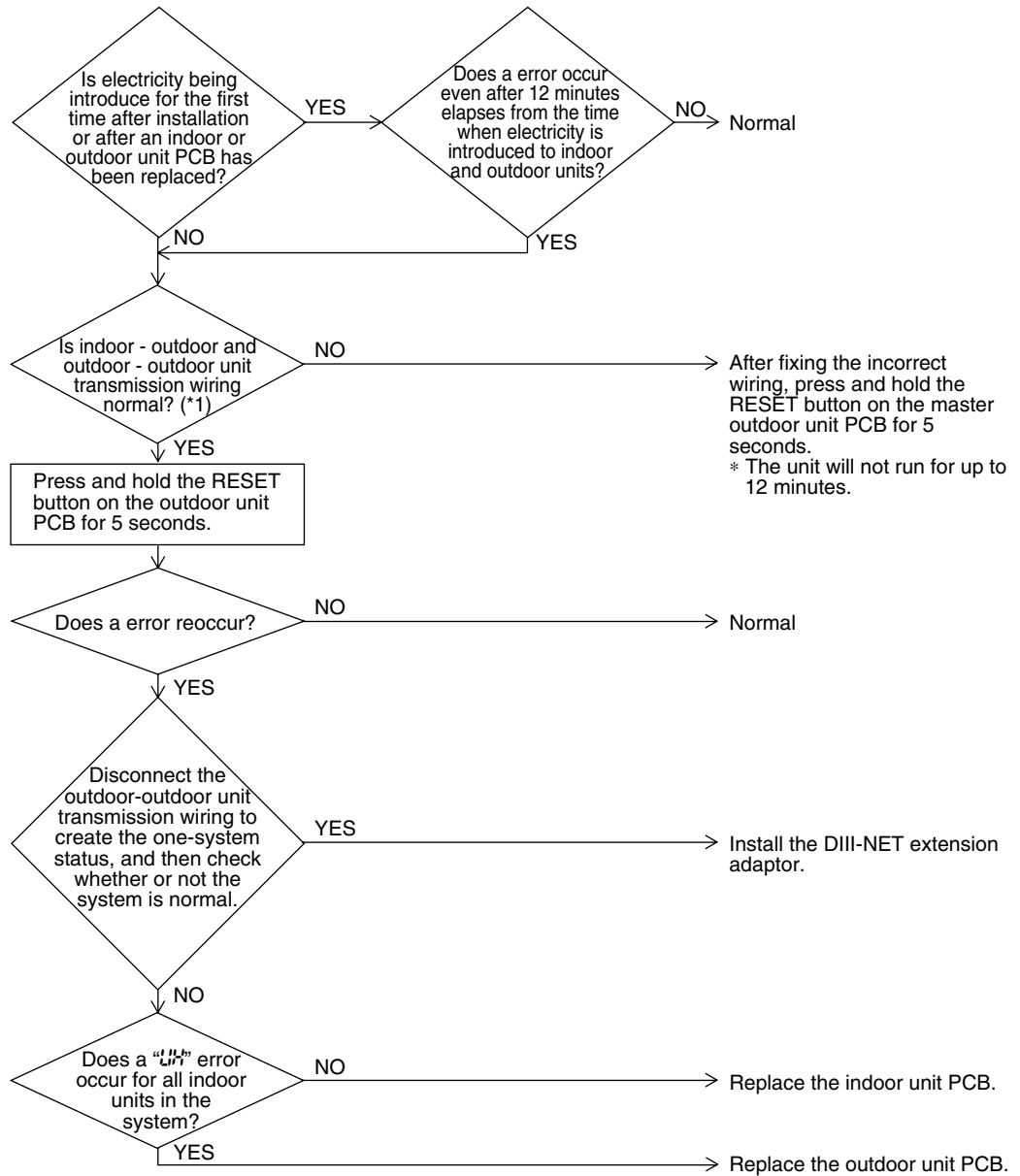

Note:

*1. Check the correct wiring “indoor-outdoor” and “outdoor-outdoor” by Installation Manual.

What is Auto Address?

This is the address automatically assigned to indoor units and outdoor units after initial power supply upon installation, or after executing rewiring (Keep pressing the **RESET** button for more than 4 seconds).

2.43 Check

CHECK 1 Check for causes of rise in high pressure

Referring to the Fault Tree Analysis (FTA) shown below, probe the defective points.

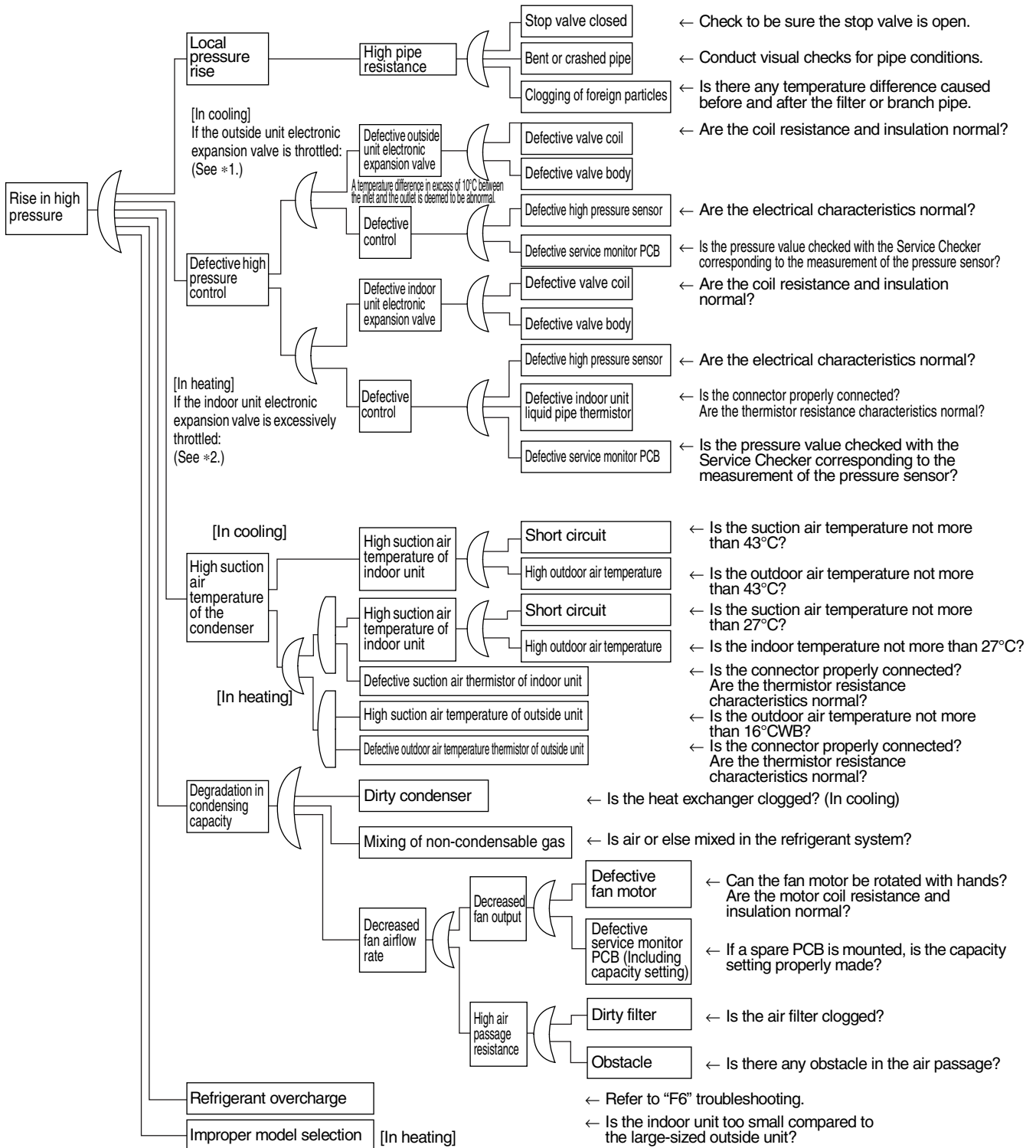

*1: In cooling, it is normal if the outside unit electronic expansion valve is fully open.

*2: In heating, the indoor unit electronic expansion valve is used for "subcooled degree control". (For details, refer to "Electronic Expansion Valve Control".)

CHECK 2 Check for causes of drop in low pressure

Referring to the Fault Tree Analysis (FTA) shown below, probe the defective points.

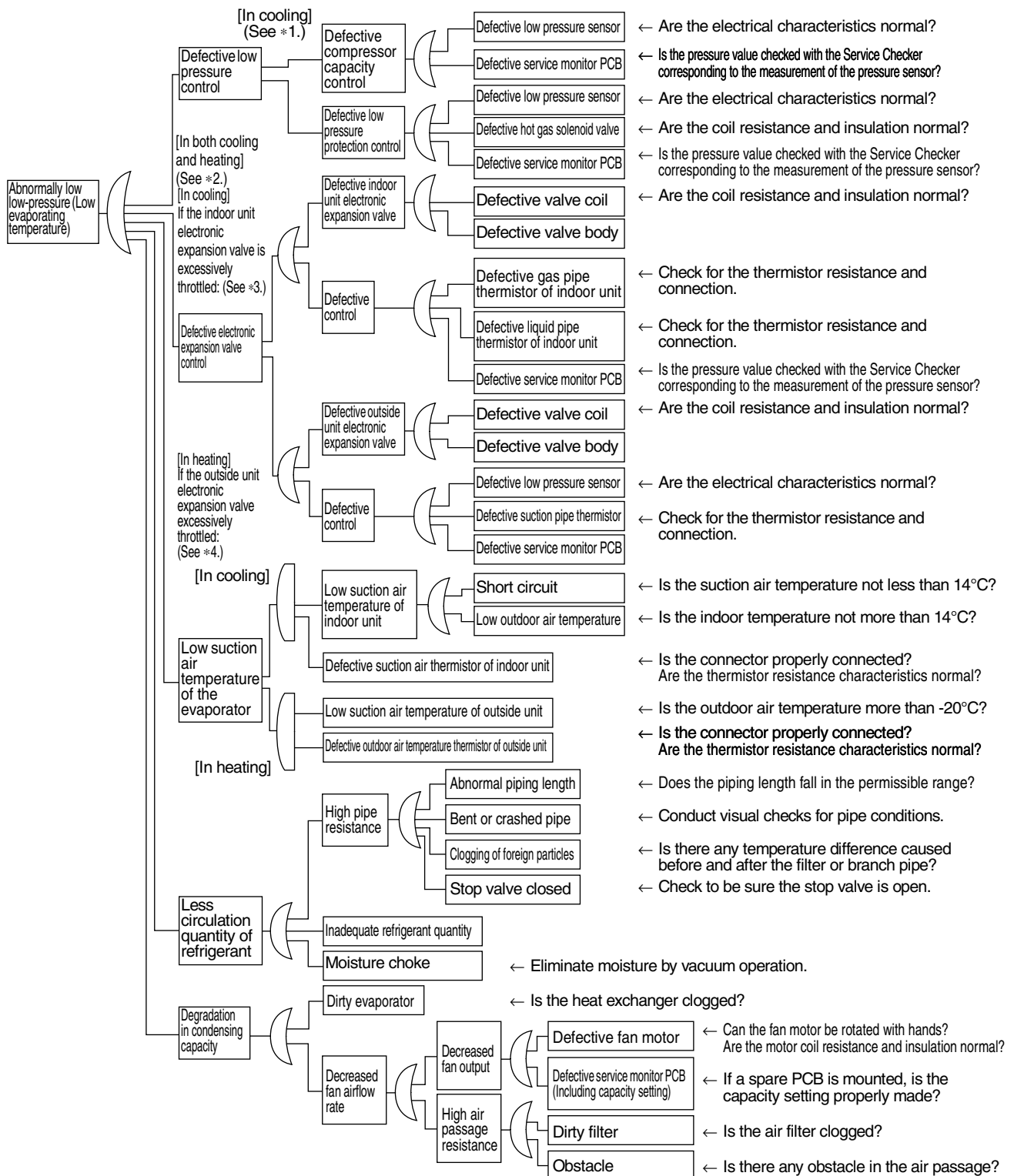

*1: For details of the compressor capacity control while in cooling, refer to "Compressor PI Control".
 *2: The "low pressure protection control" includes low pressure protection control and hot gas bypass control.
 *3: In cooling, the indoor unit electronic expansion valve is used for "superheated degree control".
 *4: In heating, the outside unit electronic expansion valve (EVM) is used for "superheated degree control of outside unit heat exchanger".

CHECK 3 Check the Factors of Overheat Operation

Identify the defective points referring to the defective factor analysis (FTA) as follows.

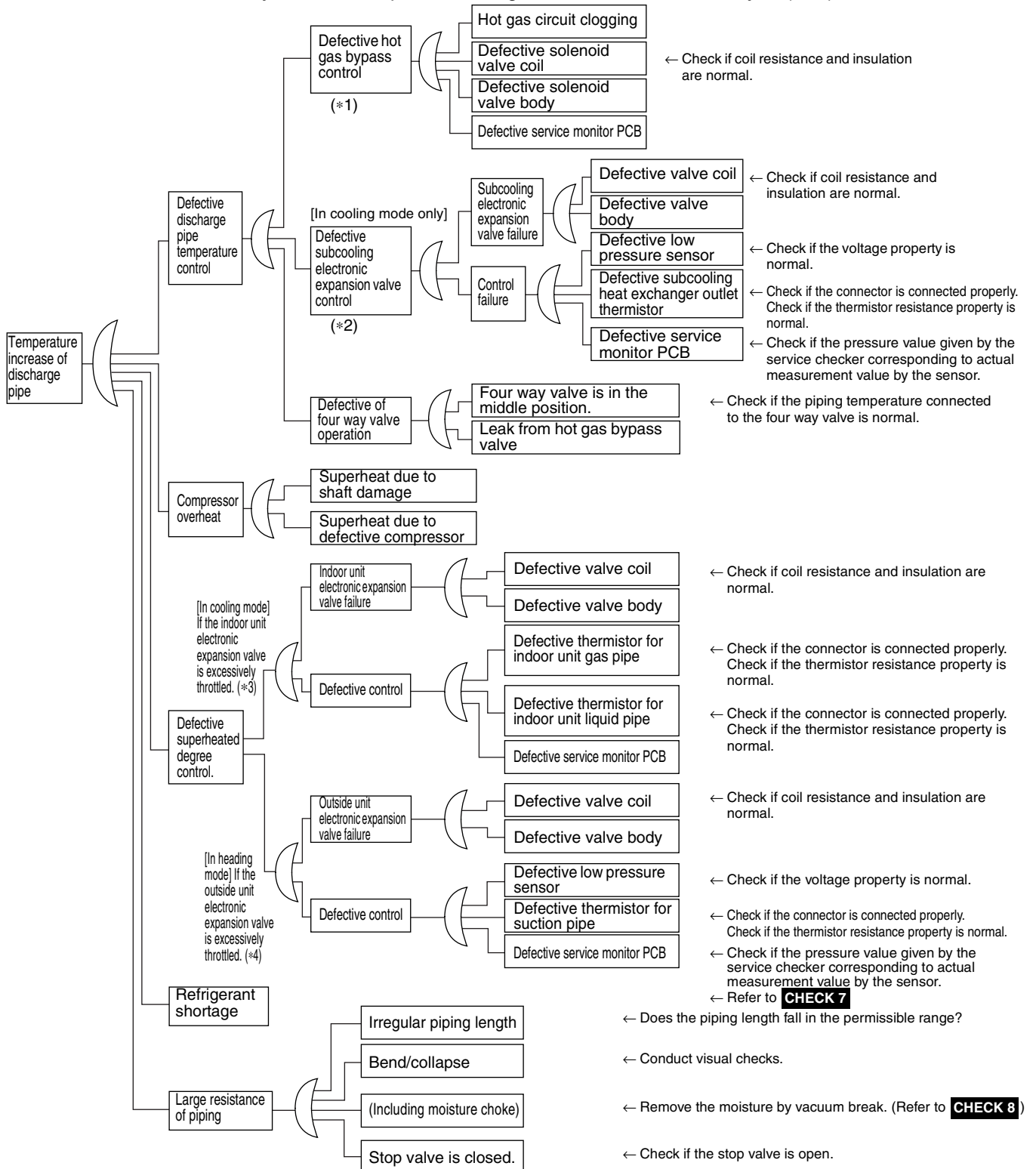

- *1: Refer to “Low pressure protection control” for hot gas bypass control.
- *2: Refer to “Subcooling electronic expansion valve control”.
- *3: “Superheating temperature control” in cooling mode is conducted by indoor unit electronic expansion valve.
- *4: Superheating temperature control in heating mode is conducted by outside unit electronic expansion valve (EVM).
- *5: Judgement criteria of superheat operation:
 (1) Suction gas superheating temperature: 10 degrees and over. (2) Discharge gas superheating temperature: 45 degrees and over, except for immediately after starting and drooping control, etc..
 (Use the above stated values as a guide. Depending on the other conditions, the unit may be normal despite the values within the above scope.)

CHECK 4 Power Transistor Check

Perform the following procedures prior to check.

- (1) Power Off.
- (2) Remove all the wiring connected to the PCB where power transistors are mounted on.

[Preparation]

- Tester

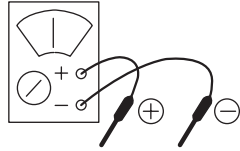

* Preparing a tester in the analog system is recommended. A tester in the digital system with diode check function will be usable.

[Point of Measurement and Judgement Criteria]

- Measure the resistance value using a tester at each point of measurement below, 10 minutes later after power OFF.

To use analog tester:

Measurement in the resistance value mode in the range of multiplying 1kΩ.

No.	Point of Measurement		Judgement Criteria	Remarks
	+	-		
1	P2	U	2 ~ 15kΩ	Due to condenser charge and so on, resistance measurement may require some time.
2	P2	V		
3	P2	W		
4	U	P2	15kΩ and above (including ∞)	
5	V	P2		
6	W	P2		
7	N3	U	2 ~ 15kΩ	
8	N3	V		
9	N3	W		
10	U	N3	2 ~ 15kΩ	
11	V	N3		
12	W	N3		

To use digital tester:

Measurement is executed in the diode check mode. (→|←)

No.	Point of Measurement		Judgement Criteria	Remarks
	+	-		
1	P2	U	1.2V and over	Due to condenser charge and so on, resistance measurement may require some time.
2	P2	V		
3	P2	W		
4	U	P2	0.3 ~ 0.7V	
5	V	P2		
6	W	P2		
7	N3	U	1.2V and over	
8	N3	V		
9	N3	W		
10	U	N3	1.2V and over	
11	V	N3		
12	W	N3		

[PCB and Circuit Diagram]

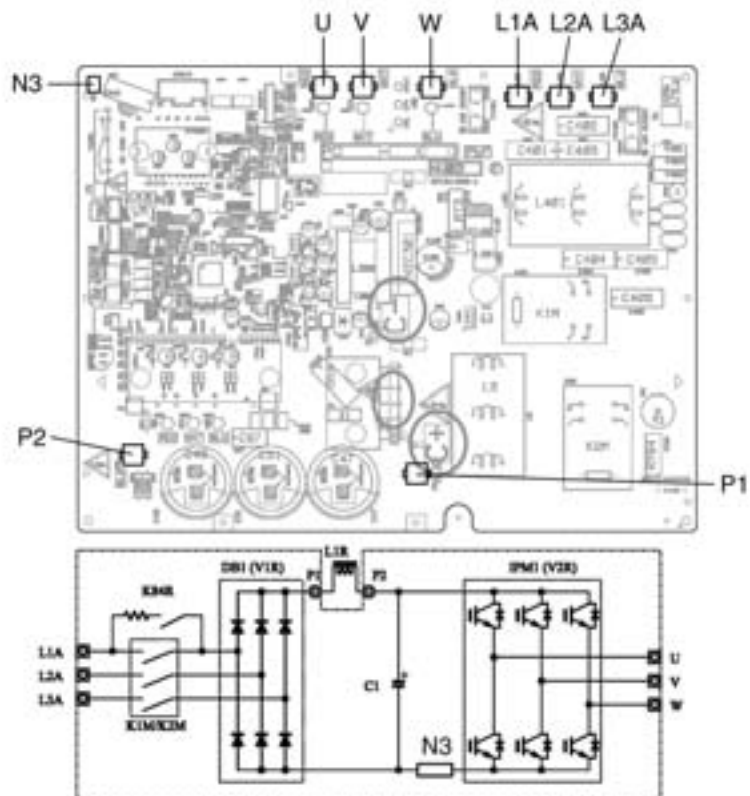

CHECK 5 Check for causes of wet operation.

Referring to the Fault Tree Analysis (FTA) shown below, identify defective points.

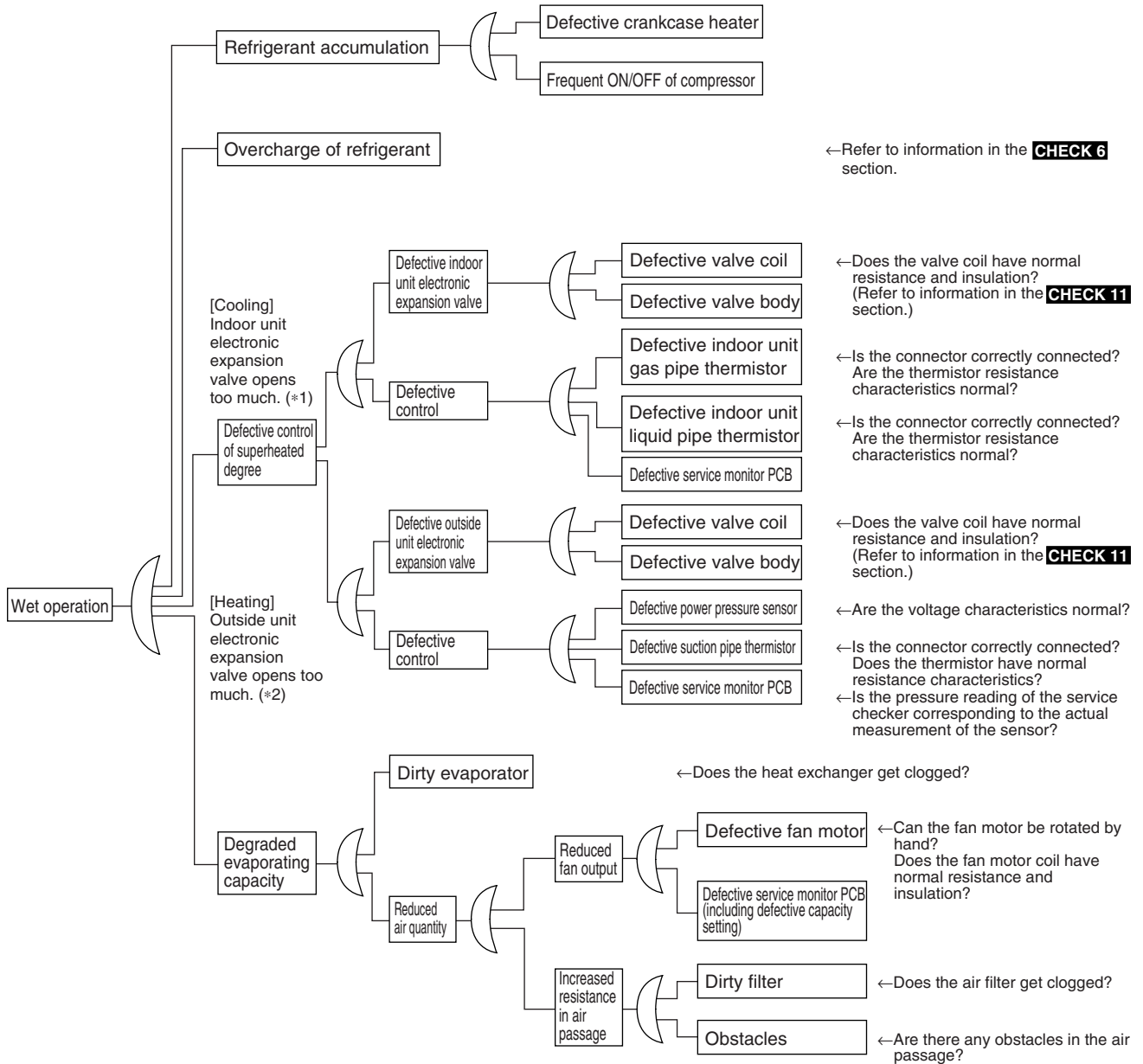

- *1: "Superheated degree control" in cooling operation is exercised with the indoor unit electronic expansion valve.
- *2: "Superheated degree control" in heating operation is exercised with the outside unit electronic expansion valve (EV1).
- *3: Guideline of superheated degree to judge as wet operation
 - ① Suction gas superheated degree: Not more than 3°C; ② Discharge gas superheated degree: Not more than 15°C, except immediately after compressor starts up or is running under drooping control.
 - (Use the values shown above as a guideline. Even if the superheated degree falls in the range, the compressor may be normal depending on other conditions.)

CHECK 6 Check for overcharge of refrigerant.

In case of VRV Systems, the only way to judge as the overcharge of refrigerant is with operating conditions due to the relationship to pressure control and electronic expansion valve control. As information for making a judgement, refer to information provided below.

Diagnosis of overcharge of refrigerant

1. High pressure rises. Consequently, overload control is exercised to cause scant cooling capacity.
2. The superheated degree of suction gas lowers (or the wet operation is performed). Consequently, the compressor becomes lower in discharge pipe temperature despite of pressure loads.
3. The subcooled degree of condensing rises. Consequently, in heating operation, the temperature of outlet air passing through the subcooled section becomes lower.

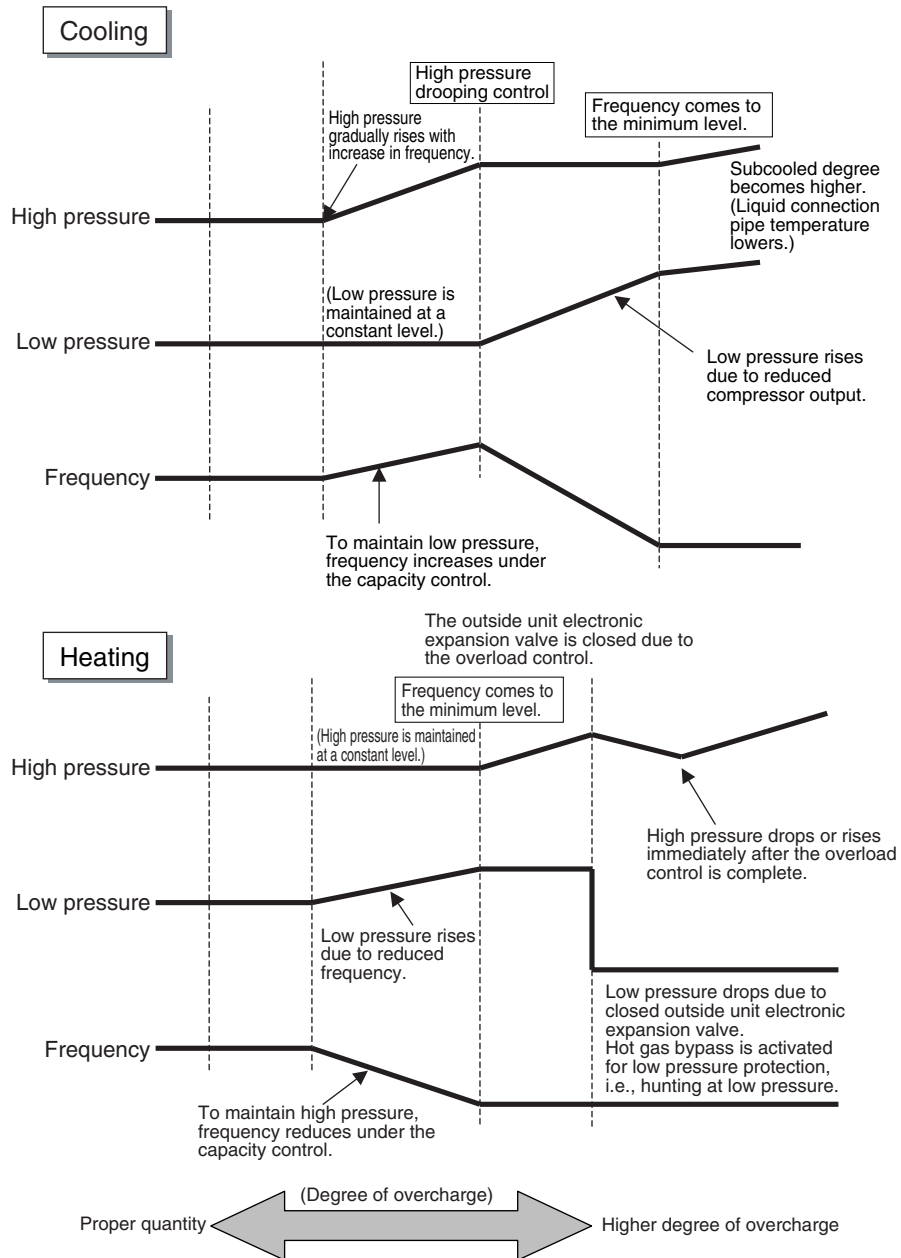

CHECK 7 Check for shortage of refrigerant.

In case of VRV Systems, the only way to judge as the shortage of refrigerant is with operating conditions due to the relationship to pressure control and electronic expansion valve control. As information for making a judgement, refer to information provided below.

Diagnosis of shortage of refrigerant

1. The superheated degree of suction gas rises. Consequently, the compressor discharge gas temperature becomes higher.
2. The superheated degree of suction gas rises. Consequently, the electronic expansion valve turns open.
3. Low pressure drops to cause the unit not to demonstrate cooling capacity (heating capacity).

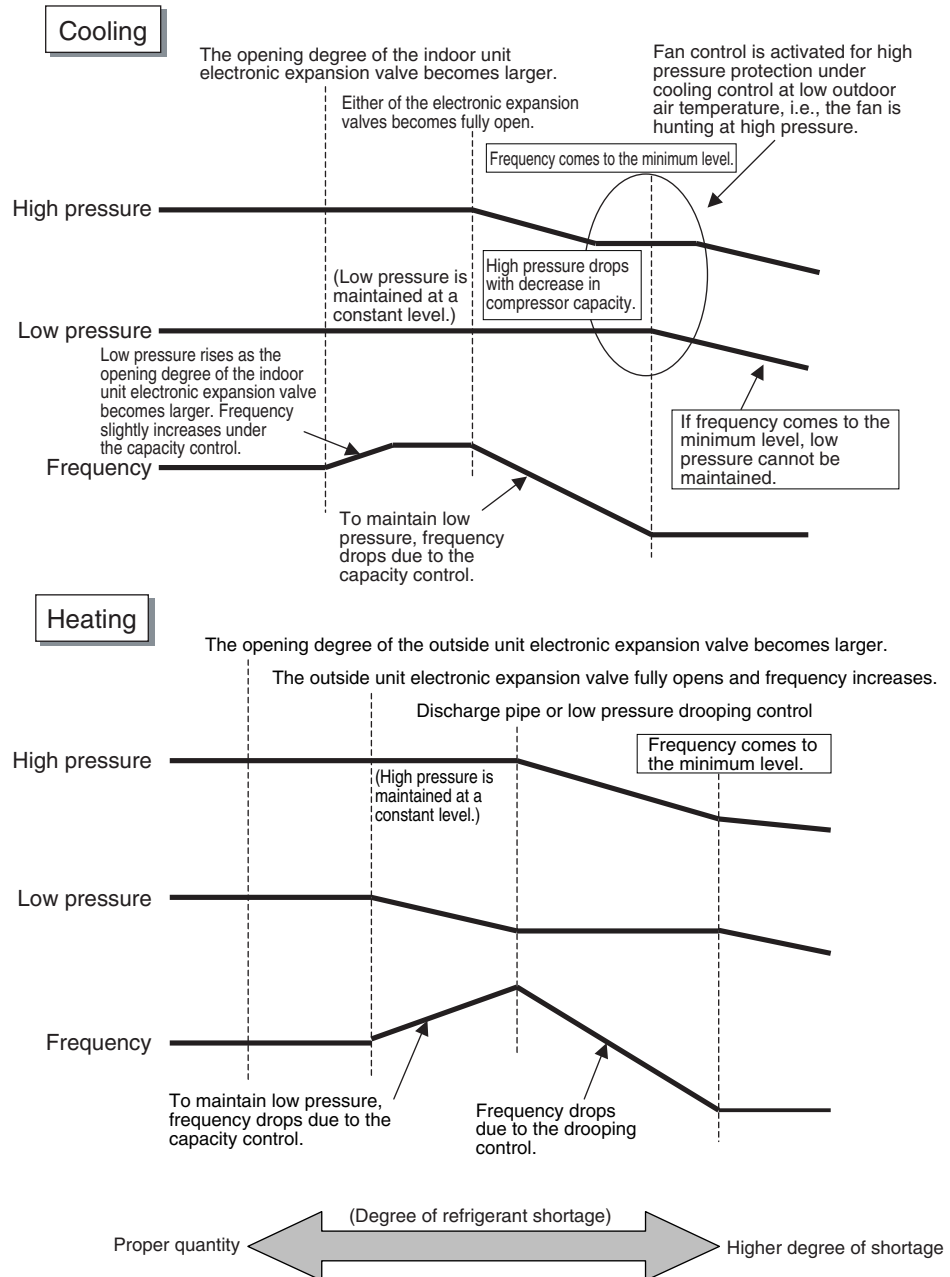

CHECK 8 Vacuuming and dehydration procedure

Conduct vacuuming and dehydration in the piping system following the procedure for <Normal vacuuming and dehydration> described below.

Furthermore, if moisture may get mixed in the piping system, follow the procedure for <Special vacuuming and dehydration> described below.

<Normal vacuuming and dehydration>

① Vacuuming and dehydration

- Use a vacuum pump that enables vacuuming up to 100.7kPa (5 torr, -755 mmHg).
- Connect manifold gauges to the service ports of liquid pipe and gas pipe and run the vacuum pump for a period of 2 or more hours to conduct evacuation to -100.7kPa or less.
- If the degree of vacuum does not reach -100.7kPa or less even though evacuation is conducted for a period of 2 hours, moisture will have entered the system or refrigerant leakage will have been caused. In this case, conduct evacuation for a period of another 1 hour.
- If the degree of vacuum does not reach -100.7kPa or less even though evacuation is conducted for a period of 3 hours, conduct leak tests.

② Leaving in vacuum state

- Leave the compressor at the degree of vacuum of -100.7kPa or less for a period of 1 hour or more, and then check to be sure that the vacuum gauge reading does not rise. (If the reading rises, moisture may have remained in the system or refrigerant leakage may have been caused.)

③ Refrigerant charge

- Purge air from the manifold gauge connection hoses, and then charge a necessary quantity of refrigerant.

<Special vacuuming and dehydration> - In case moisture may get mixed in the piping*

① Vacuuming and dehydration

- Follow the same procedure as that for 1) Normal vacuuming and dehydration described above.

② Vacuum break

- Pressurize with nitrogen gas up to 0.05MPa.

③ Vacuuming and dehydration

- Conduct vacuuming and dehydration for a period of 1 hour or more. If the degree of vacuum does not reach -100.7kPa or less even though evacuation is conducted for a period of two hours or more, repeat vacuum break - vacuuming and dehydration.

④ Leaving in vacuum state

- Leave the compressor at the degree of vacuum of -100.7kPa or less for a period of 1 hour or more, and then check to be sure that the vacuum gauge reading does not rise.

⑤ Refrigerant charge

- Purge air from the manifold gauge connection hoses, and then charge a necessary quantity of refrigerant.

- * In case of construction during rainy reason, if dew condensation occurs in the piping due to extended construction period, or rainwater or else may enter the piping during construction work:

CHECK 9 List of inverter-related error codes

	Code	Name	Condition for determining error	Major cause
Compressor current	L5	Instantaneous overcurrent of inverter compressor	<ul style="list-style-type: none"> Inverter output current exceeds 32.3A even instantaneously. 	<ul style="list-style-type: none"> Liquid sealing Defective compressor Defective inverter PCB
	L8	Overcurrent of inverter compressor (Electronic thermal)	<ul style="list-style-type: none"> Compressor overload running An overcurrent of 19.0A or more continues for a period of 5 consecutive seconds or that of 16.1A or more continues for a period of 260 consecutive seconds. For 230V units: A current of 33.5A or more continues for a period of consecutive 5 sec. or that of 27.6A or more continues for a period of consecutive 260 sec. The inverter loses synchronization. 	<ul style="list-style-type: none"> Back-flow of compressor liquid Sudden changes in loads Disconnected compressor wiring Defective inverter PCB
Protection device and others	L1	Defective inverter PCB	<ul style="list-style-type: none"> No output is given. 	<ul style="list-style-type: none"> Defective heavy current part of compressor
	L9	Defective startup of inverter compressor	<ul style="list-style-type: none"> The compressor motor fails to start up. 	<ul style="list-style-type: none"> Liquid sealing or defective compressor Excessive oil or refrigerant Defective inverter PCB
	E5	Inverter compressor lock	<ul style="list-style-type: none"> The compressor is in the locked status (does not rotate). 	<ul style="list-style-type: none"> Defective compressor
	L4	Radiation fin temperature rise	<ul style="list-style-type: none"> The radiation fin temperature reaches 188.6°F or more (while in operation). 	<ul style="list-style-type: none"> Defective fan Running in overload for an extended period of time Defective inverter PCB
	U2	Power supply voltage error	<ul style="list-style-type: none"> The inverter power supply voltage is high or low. 	<ul style="list-style-type: none"> Power supply error Defective inverter PCB
	P1	Imbalanced power supply	<ul style="list-style-type: none"> Power supply voltages get significantly imbalanced among three phases. 	<ul style="list-style-type: none"> Power supply error (imbalanced voltages of 2% or more) Defective inverter PCB Dead inverter PCB
	LC	Transmission error (between inverter PCB and service monitor PCB)	<ul style="list-style-type: none"> With the outdoor unit PCB, no communications are carried out across service monitor PCB - inverter PCB - fan PCB. 	<ul style="list-style-type: none"> Broken wire in communication line Defective service monitor PCB Defective inverter PCB Defective fan PCB
	PJ	PCB mismatching	<ul style="list-style-type: none"> Any PCB of specification different from that of the product is connected. 	<ul style="list-style-type: none"> PCB of different specification mounted
	P4	Defective radiation fin thermistor	<ul style="list-style-type: none"> The radiation fin thermistor gets short circuited or open. 	<ul style="list-style-type: none"> Defective radiation fin thermistor

CHECK 10 Concept of inverter-related error codes

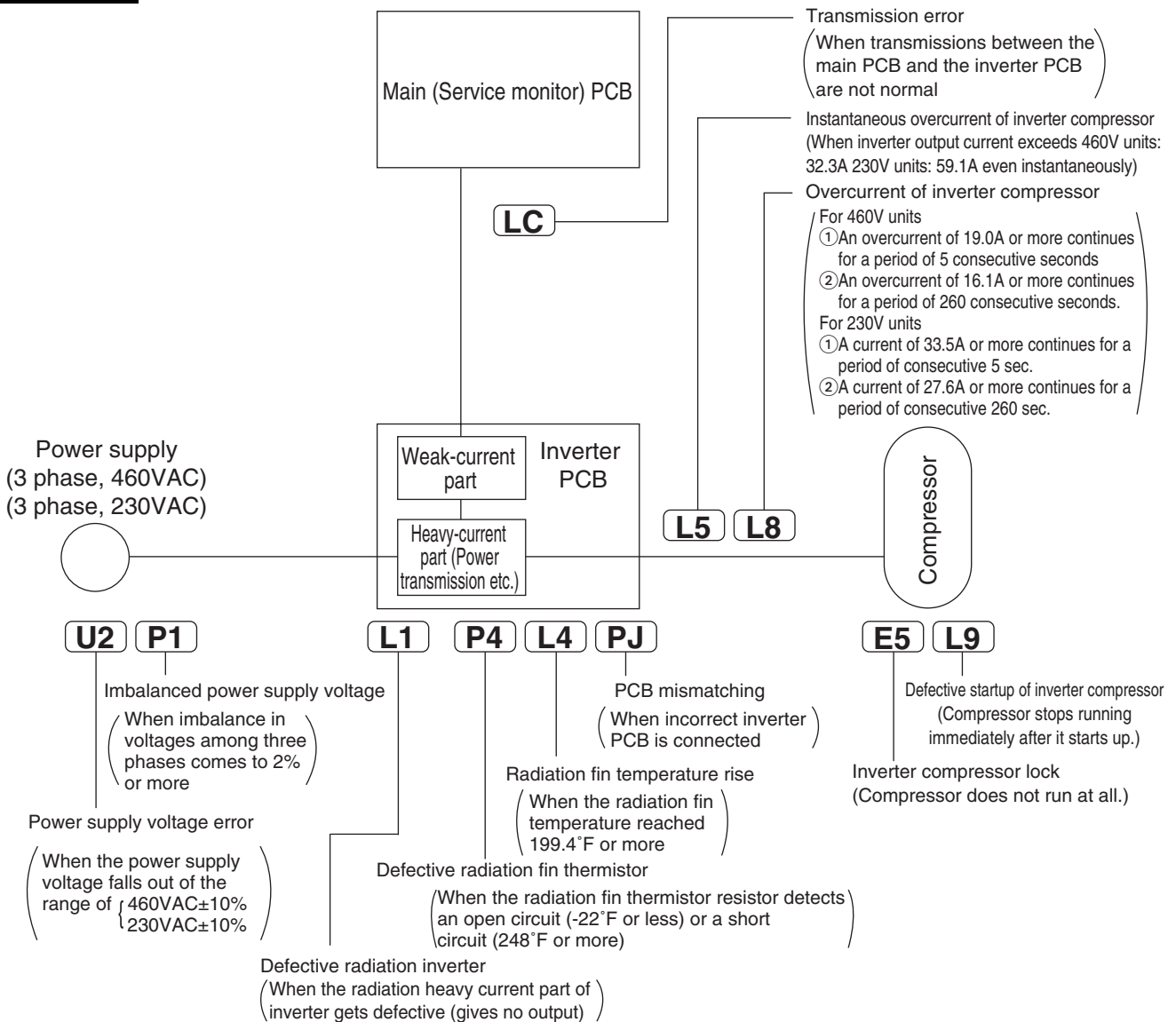

Error codes related to compressor current

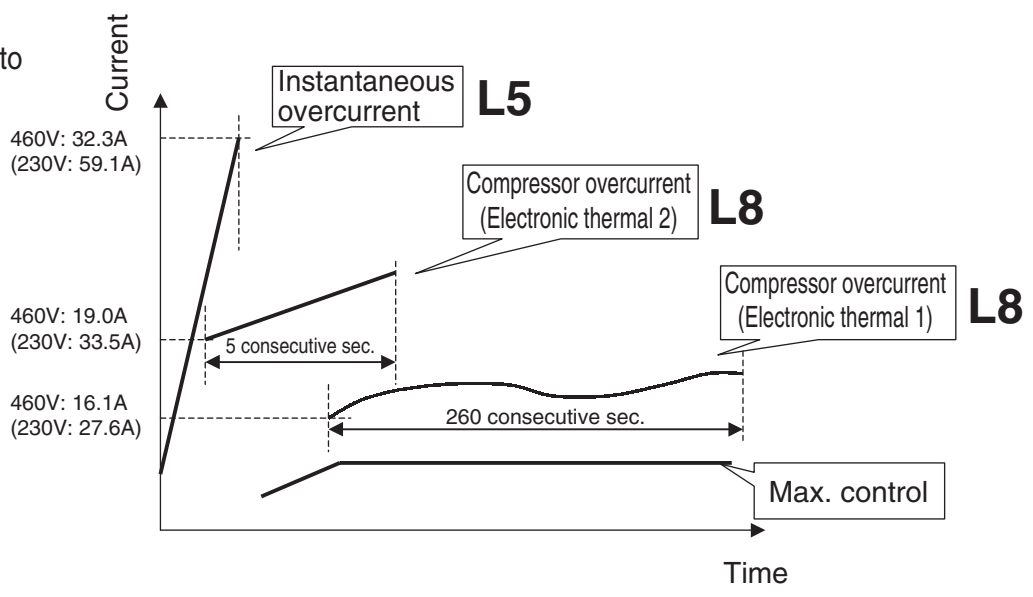

CHECK 11 Thermistor Resistance / Temperature Characteristics

Indoor unit For air suction R1T
 For liquid pipe R2T
 For gas pipe R3T

Radiation fin thermistor R1T

Outdoor unit For outdoor air R1T
 For receiver liquid level R2T
 For refrigerant regulator liquid pipe R4T
 For subcooling heat exchanger outlet R5T
 For liquid pipe R6T
 For receiver gas vent outlet R7T
 For suction pipe R8T
 For heat exchanger deicer R9T

T°C	kΩ
-10	-
-8	-
-6	88.0
-4	79.1
-2	71.1
0	64.1
2	57.8
4	52.3
6	47.3
8	42.9
10	38.9
12	35.3
14	32.1
16	29.2
18	26.6
20	24.3
22	22.2
24	20.3
26	18.5
28	17.0
30	15.6
32	14.2
34	13.1
36	12.0
38	11.1
40	10.3
42	9.5
44	8.8
46	8.2
48	7.6
50	7.0
52	6.7
54	6.0
56	5.5
58	5.2
60	4.79
62	4.46
64	4.15
66	3.87
68	3.61
70	3.37
72	3.15
74	2.94
76	2.75
78	2.51
80	2.41
82	2.26
84	2.12
86	1.99
88	1.87
90	1.76
92	1.65
94	1.55
96	1.46
98	1.38

T°C	kΩ
-20	197.81
-19	186.53
-18	175.97
-17	166.07
-16	156.80
-15	148.10
-14	139.94
-13	132.28
-12	125.09
-11	118.34
-10	111.99
-9	106.03
-8	100.41
-7	95.14
-6	90.17
-5	85.49
-4	81.08
-3	76.93
-2	73.01
-1	69.32
0	65.84
1	62.54
2	59.43
3	56.49
4	53.71
5	51.09
6	48.61
7	46.26
8	44.05
9	41.95
10	39.96
11	38.08
12	36.30
13	34.62
14	33.02
15	31.50
16	30.06
17	28.70
18	27.41
19	26.18
20	25.01
21	23.91
22	22.85
23	21.85
24	20.90
25	20.00
26	19.14
27	18.32
28	17.54
29	16.80
30	16.10

T°C	kΩ
-19.5	192.08
-18.5	181.16
-17.5	170.94
-16.5	161.36
-15.5	152.38
-14.5	143.96
-13.5	136.05
-12.5	128.63
-11.5	121.66
-10.5	115.12
-9.5	108.96
-8.5	103.18
-7.5	97.73
-6.5	92.61
-5.5	87.79
-4.5	83.25
-3.5	78.97
-2.5	74.94
-1.5	71.14
-0.5	67.56
0.5	64.17
1.5	60.96
2.5	57.94
3.5	55.08
4.5	52.38
5.5	49.83
6.5	47.42
7.5	45.14
8.5	42.98
9.5	40.94
10.5	39.01
11.5	37.18
12.5	35.45
13.5	33.81
14.5	32.25
15.5	30.77
16.5	29.37
17.5	28.05
18.5	26.78
19.5	25.59
20.5	24.45
21.5	23.37
22.5	22.35
23.5	21.37
24.5	20.45
25.5	19.56
26.5	18.73
27.5	17.93
28.5	17.17
29.5	16.45
30.5	15.76

T°C	kΩ
30	16.10
31	15.43
32	14.79
33	14.18
34	13.59
35	13.04
36	12.51
37	12.01
38	11.52
39	11.06
40	10.63
41	10.21
42	9.81
43	9.42
44	9.06
45	8.71
46	8.37
47	8.05
48	7.75
49	7.46
50	7.18
51	6.91
52	6.65
53	6.41
54	6.18
55	5.95
56	5.74
57	5.54
58	5.34
59	5.14
60	4.96
61	4.79
62	4.62
63	4.46
64	4.30
65	4.16
66	4.01
67	3.88
68	3.75
69	3.62
70	3.50
71	3.38
72	3.27
73	3.16
74	3.06
75	2.96
76	2.86
77	2.77
78	2.68
79	2.60
80	2.51

T°C	kΩ
30.5	15.76
31.5	15.10
32.5	14.48
33.5	13.88
34.5	13.31
35.5	12.77
36.5	12.25
37.5	11.76
38.5	11.29
39.5	10.84
40.5	10.41
41.5	10.00
42.5	9.61
43.5	9.24
44.5	8.88
45.5	8.54
46.5	8.21
47.5	7.90
48.5	7.60
49.5	7.31
50.5	7.04
51.5	6.78
52.5	6.53
53.5	6.53
54.5	6.53
55.5	6.53
56.5	6.06
57.5	5.84
58.5	5.43
59.5	5.05
60.5	4.87
61.5	4.70
62.5	4.54
63.5	4.38
64.5	4.23
65.5	4.08
66.5	3.94
67.5	3.81
68.5	3.68
69.5	3.56
70.5	3.44
71.5	3.32
72.5	3.21
73.5	3.11
74.5	3.01
75.5	2.91
76.5	2.82
77.5	2.72
78.5	2.64
79.5	2.55
80.5	2.47

**Outdoor Unit
Thermistors for
Discharge Pipe
(R3T, R31~33T)**

0	640.44	0.5	624.65	50	72.32	50.5	70.96	100	13.35	100.5	13.15
1	609.31	1.5	594.43	51	69.64	51.5	68.34	101	12.95	101.5	12.76
2	579.96	2.5	565.78	52	67.06	52.5	65.82	102	12.57	102.5	12.38
3	552.00	3.5	538.63	53	64.60	53.5	63.41	103	12.20	103.5	12.01
4	525.63	4.5	512.97	54	62.24	54.5	61.09	104	11.84	104.5	11.66
5	500.66	5.5	488.67	55	59.97	55.5	58.87	105	11.49	105.5	11.32
6	477.01	6.5	465.65	56	57.80	56.5	56.75	106	11.15	106.5	10.99
7	454.60	7.5	443.84	57	55.72	57.5	54.70	107	10.83	107.5	10.67
8	433.37	8.5	423.17	58	53.72	58.5	52.84	108	10.52	108.5	10.36
9	413.24	9.5	403.57	59	51.98	59.5	50.96	109	10.21	109.5	10.06
10	394.16	10.5	384.98	60	49.96	60.5	49.06	110	9.92	110.5	9.78
11	376.05	11.5	367.35	61	48.19	61.5	47.33	111	9.64	111.5	9.50
12	358.88	12.5	350.62	62	46.49	62.5	45.67	112	9.36	112.5	9.23
13	342.58	13.5	334.74	63	44.86	63.5	44.07	113	9.10	113.5	8.97
14	327.10	14.5	319.66	64	43.30	64.5	42.54	114	8.84	114.5	8.71
15	312.41	15.5	305.33	65	41.79	65.5	41.06	115	8.59	115.5	8.47
16	298.45	16.5	291.73	66	40.35	66.5	39.65	116	8.35	116.5	8.23
17	285.18	17.5	278.80	67	38.96	67.5	38.29	117	8.12	117.5	8.01
18	272.58	18.5	266.51	68	37.63	68.5	36.98	118	7.89	118.5	7.78
19	260.60	19.5	254.72	69	36.34	69.5	35.72	119	7.68	119.5	7.57
20	249.00	20.5	243.61	70	35.11	70.5	34.51	120	7.47	120.5	7.36
21	238.36	21.5	233.14	71	33.92	71.5	33.35	121	7.26	121.5	7.16
22	228.05	22.5	223.08	72	32.78	72.5	32.23	122	7.06	122.5	6.97
23	218.24	23.5	213.51	73	31.69	73.5	31.15	123	6.87	123.5	6.78
24	208.90	24.5	204.39	74	30.63	74.5	30.12	124	6.69	124.5	6.59
25	200.00	25.5	195.71	75	29.61	75.5	29.12	125	6.51	125.5	6.42
26	191.53	26.5	187.44	76	28.64	76.5	28.16	126	6.33	126.5	6.25
27	183.46	27.5	179.57	77	27.69	77.5	27.24	127	6.16	127.5	6.08
28	175.77	28.5	172.06	78	26.79	78.5	26.35	128	6.00	128.5	5.92
29	168.44	29.5	164.90	79	25.91	79.5	25.49	129	5.84	129.5	5.76
30	161.45	30.5	158.08	80	25.07	80.5	24.66	130	5.69	130.5	5.61
31	154.79	31.5	151.57	81	24.26	81.5	23.87	131	5.54	131.5	5.46
32	148.43	32.5	145.37	82	23.48	82.5	23.10	132	5.39	132.5	5.32
33	142.37	33.5	139.44	83	22.73	83.5	22.36	133	5.25	133.5	5.18
34	136.59	34.5	133.79	84	22.01	84.5	21.65	134	5.12	134.5	5.05
35	131.06	35.5	128.39	85	21.31	85.5	20.97	135	4.98	135.5	4.92
36	125.79	36.5	123.24	86	20.63	86.5	20.31	136	4.86	136.5	4.79
37	120.76	37.5	118.32	87	19.98	87.5	19.67	137	4.73	137.5	4.67
38	115.95	38.5	113.62	88	19.36	88.5	19.05	138	4.61	138.5	4.55
39	111.35	39.5	109.13	89	18.75	89.5	18.46	139	4.49	139.5	4.44
40	106.96	40.5	104.84	90	18.17	90.5	17.89	140	4.38	140.5	4.32
41	102.76	41.5	100.73	91	17.61	91.5	17.34	141	4.27	141.5	4.22
42	98.75	42.5	96.81	92	17.07	92.5	16.80	142	4.16	142.5	4.11
43	94.92	43.5	93.06	93	16.54	93.5	16.29	143	4.06	143.5	4.01
44	91.25	44.5	89.47	94	16.04	94.5	15.79	144	3.96	144.5	3.91
45	87.74	45.5	86.04	95	15.55	95.5	15.31	145	3.86	145.5	3.81
46	84.38	46.5	82.75	96	15.08	96.5	14.85	146	3.76	146.5	3.72
47	81.16	47.5	79.61	97	14.62	97.5	14.40	147	3.67	147.5	3.62
48	78.09	48.5	76.60	98	14.18	98.5	13.97	148	3.58	148.5	3.54
49	75.14	49.5	73.71	99	13.76	99.5	13.55	149	3.49	149.5	3.45
50	72.32	50.5	70.96	100	13.35	100.5	13.15	150	3.41	150.5	3.37

CHECK 12 Pressure Sensor

$$P_H = 1.38V_H - 0.69$$

$$P_L = 0.57V_L - 0.28$$

P_H : High pressure (MPa)

P_L : Low pressure (MPa)

V_H : Output Voltage [High Side] V_{DC}

V_L : Output Voltage [Low Side] V_{DC}

Detected Pressure

P_H, P_L
(kg/cm²) MPa

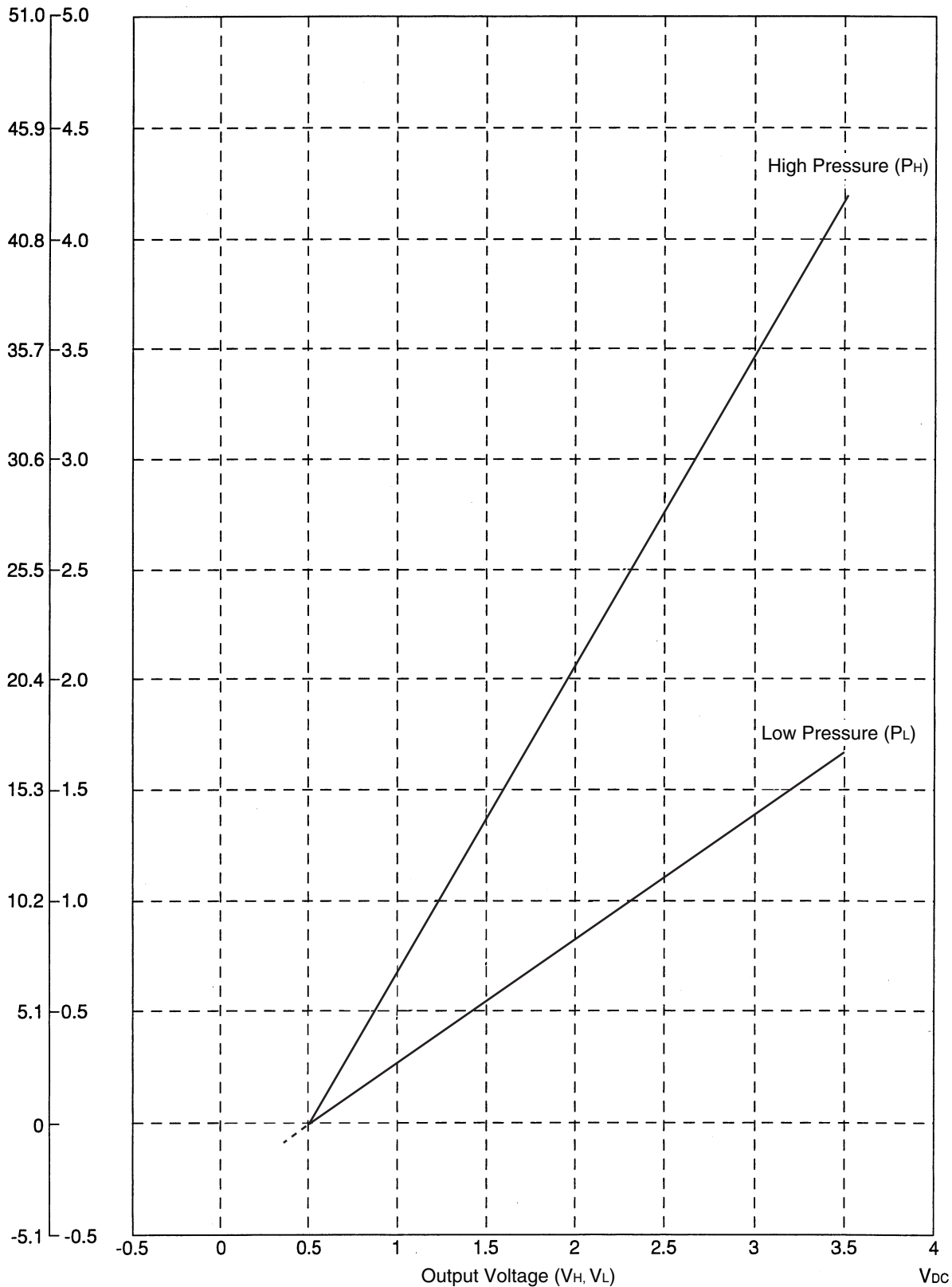

CHECK 13 Broken Wire Check of the Connecting Wires

1. Procedure for checking outdoor-outdoor unit transmission wiring for broken wires
 On the system shown below, turn OFF the power supply to all equipment, short-circuit between the outdoor-outdoor unit terminal parts F1 and F2 in the "Outdoor Unit A" that is farthest from the centralized remote controller, and then conduct continuity checks between the transmission wiring terminal blocks F1 and F2 of the centralized remote controller using a multiple meter. If there is continuity between the said terminal blocks, the outdoor-outdoor unit transmission wiring has no broken wires in it.

If there is no continuity, the transmission wiring may have broken wires. With the outdoor-outdoor unit terminal parts of the "Outdoor Unit A" short-circuited, conduct continuity checks between the transmission wiring terminal blocks F1 and F2 of the unified ON/OFF controller. If there is no continuity as well, conduct continuity checks between the outdoor-outdoor unit terminal parts of the "Outdoor Unit E", between the outdoor-outdoor unit terminal parts of the "Outdoor Unit D", between the outdoor-outdoor unit terminal parts of the "Outdoor Unit C", ... in the order described, thus identifying the place with continuity.

If the place with continuity can be identified, there may be broken wires in places before the said place with continuity.

2. Procedure for checking indoor-outdoor unit transmission wiring for broken wires (for checking the indoor-outdoor unit transmission wiring of the "Outdoor Unit C" for broken wires)

Turn OFF the power supply to all equipment, short-circuit between the indoor-outdoor unit terminal parts F1 and F2 in the "Outdoor Unit C, and then conduct continuity checks between the transmission wirings F1 and F2 of the "Indoor Unit a" that is farthest from the "Outdoor Unit C" using a multiple meter. If there is continuity between the said transmission wirings, the indoor-outdoor unit transmission wiring has no broken wires in it.

If there is no continuity, the transmission wiring may have broken wires. With the indoor-outdoor unit terminal parts of the "Outdoor Unit C" short-circuited, identify the place with continuity in the transmission wiring of the "Indoor Unit b", transmission wiring of the "Indoor Unit c", and transmission wiring of the "Indoor Unit d" in the order described.

If the place with continuity can be identified, there may be broken wires in places before the said place with continuity.

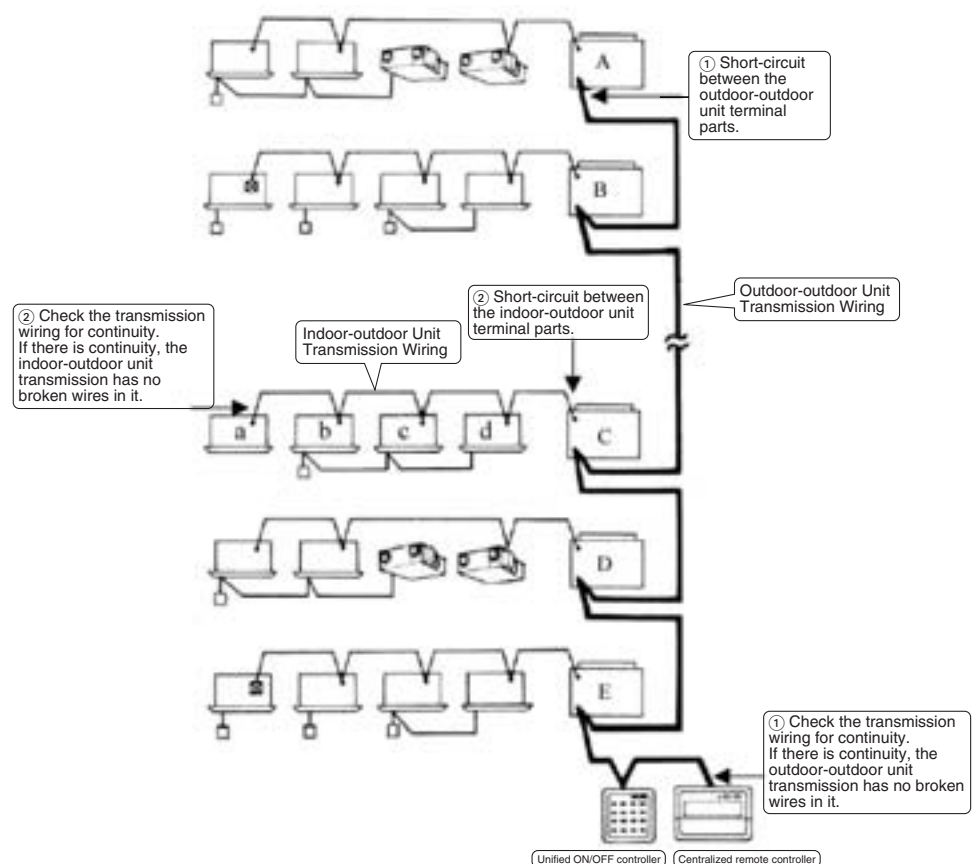

CHECK 14 Master Unit Central Connector Setting Table

The master unit central setting connector (CN1/X1A) is mounted at the factory.

- To independently use a single unit of the intelligent Touch Controller or a single unit of the centralized remote controller, do not dismount the master unit central setting connector (i.e., use the connector with the factory setting unchanged).
- To independently use the schedule timer, insert an independent-use setting connector. No independent-use setting connector has been mounted at the factory. Insert the connector, which is attached to the casing of the main unit, in the PCB (CN1/X1A). (Independent-use connector=Master unit central setting connector)
- To use two or more centralized controller in combination, make settings according to the table shown below.

Pattern	Centralized controller connection pattern				Setting of master unit central setting connector(*2)				
	intelligent Touch Controller	Centralized remote controller	Unified ON/OFF controller	Schedule timer	intelligent Touch Controller	Centralized remote controller	Unified ON/OFF controller	Schedule timer	
①	1 to 2 units	/	/	× (*1)	Only a single unit: "Provided", Others: "Not provided"	/	/	/	
②	1 unit	1 unit	/	× (*1)	Provided	Not provided	/	/	
③			/	× (*1)			/	/	
④	1 to 2 units	/	1 to 8 units	× (*1)	Only a single unit: "Provided", Others: "Not provided"	/	All "Not provided"	/	
⑤	/	1 to 4 units	/	/	Only a single unit: "Provided", Others: "Not provided"	Only a single unit: "Provided", Others: "Not provided"	/	/	
⑥	/		1 to 16 units	1 unit			/	All "Not provided"	Not provided
⑦	/		/	/			/	/	/
⑧	/		/	1 unit			/	/	Not provided
⑨	/	/	/	/	/	/	Only a single unit: "Provided", Others: "Not provided"	/	
⑩	/	/	1 to 16 units	1 unit	/	/	Only a single unit: "Provided", Others: "Not provided"	Not provided	
⑪	/	/	/	1 unit	/	/	/	Provided	

(*1) The intelligent Touch Controller and the schedule timer are not available for combined use.

(*2) The intelligent Touch Controller, centralized remote controller, and the unified ON/OFF controller have been set to "Provided with the master unit central setting connector" at the factory. The schedule timer has been set to "Not provided with the master unit central setting connector" at the factory, which is attached to the casing of the main unit.

CHECK 15 Master-Slave Unit Setting Table

Combination of intelligent Touch Controller and Centralized Remote Controller



*	#1		#2		#3		#4	
Pattern	1-00~4-15	Master/Slave	5-00~8-15	Master/Slave	1-00~4-15	Master/Slave	5-00~8-15	Master/Slave
①	CRC	Master	CRC	Master	CRC	Slave	CRC	Slave
②	CRC	Master	—	—	CRC	Slave	—	—
③	intelligent Touch Controller	Master	—	—	intelligent Touch Controller	Slave	—	—
④	CRC	Master	—	—	intelligent Touch Controller	Slave	—	—
⑤	intelligent Touch Controller	Master	—	—	CRC	Slave	—	—
⑥	CRC	Master	—	—	—	—	—	—
⑦	intelligent Touch Controller	Master	—	—	—	—	—	—

CRC: Centralized remote controller <DCS302CA61>

intelligent Touch Controller: <DCS601C51>

The patterns marked with "" have nothing to do with those described in the list of Setting of master unit central setting connector.

Part 7 Appendix

1. Piping Diagrams.....	196
2. Wiring Diagrams.....	199
3. Accessories.....	202
3.1 Optional Accessories.....	202

1. Piping Diagrams

RQYQ8PY1B

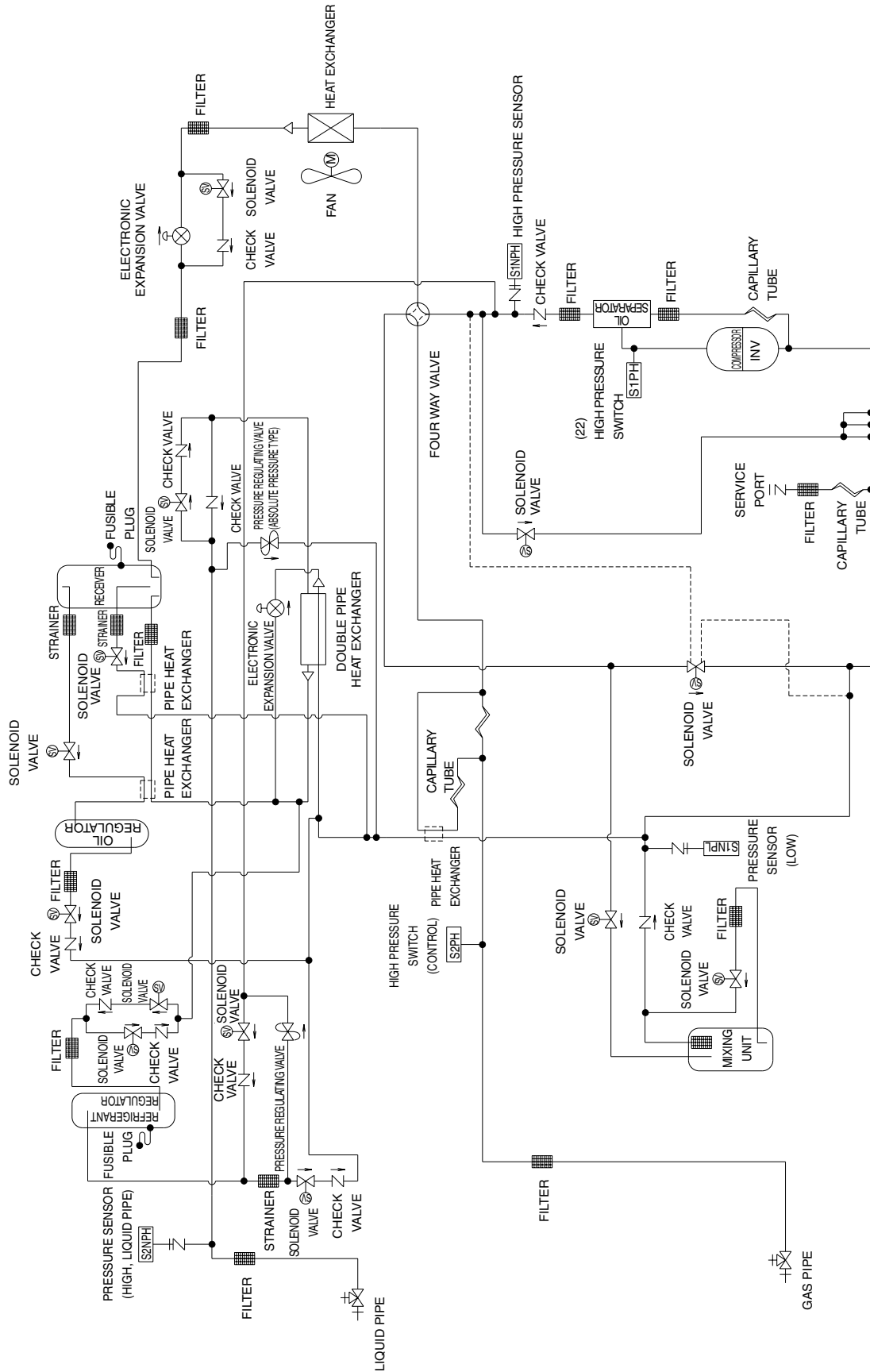

3D069117A

RQYQ10PY1B / RQYQ12PY1B

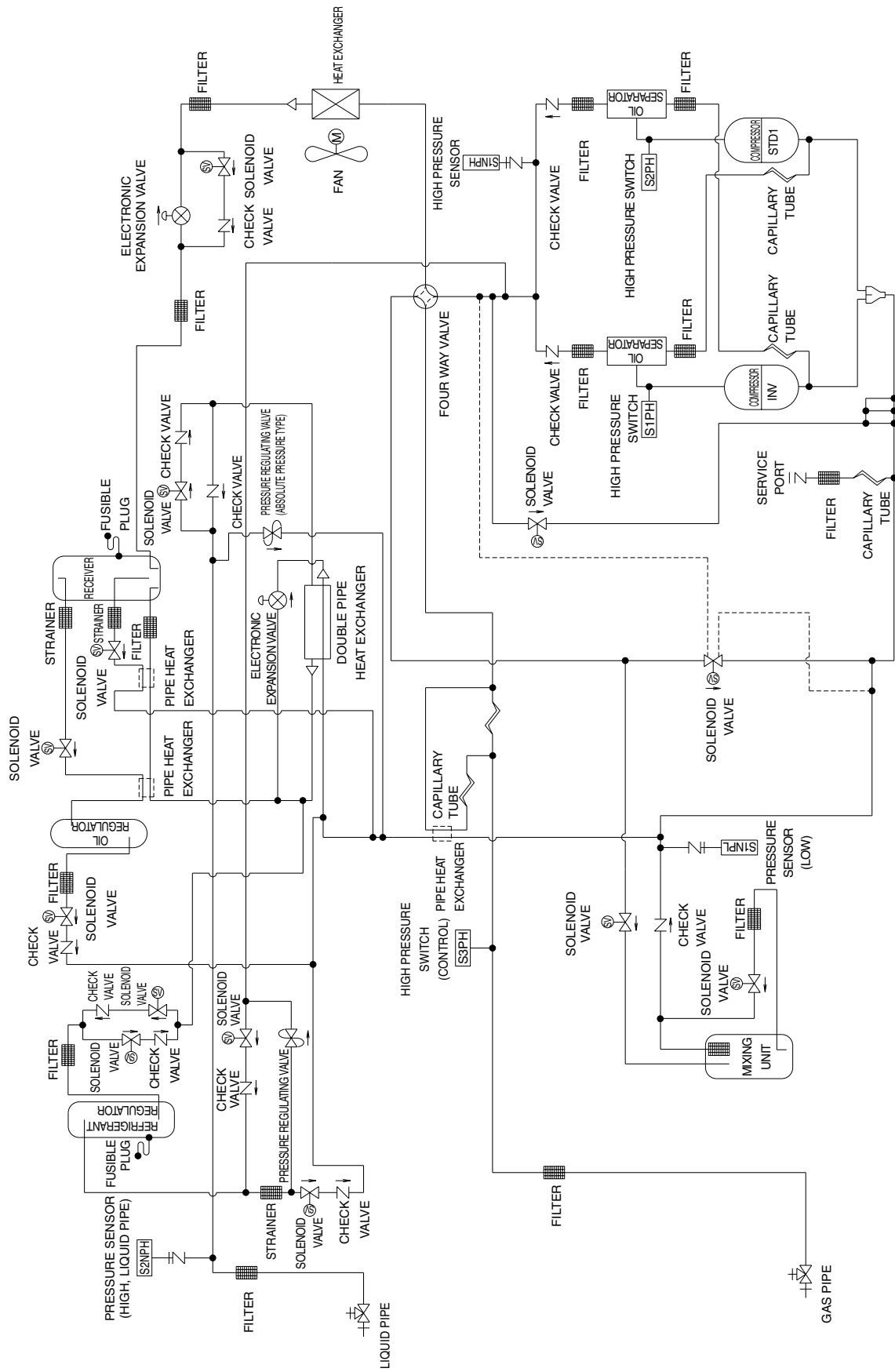

3D069109A

RQYQ14PY1B / RQYQ16PY1B

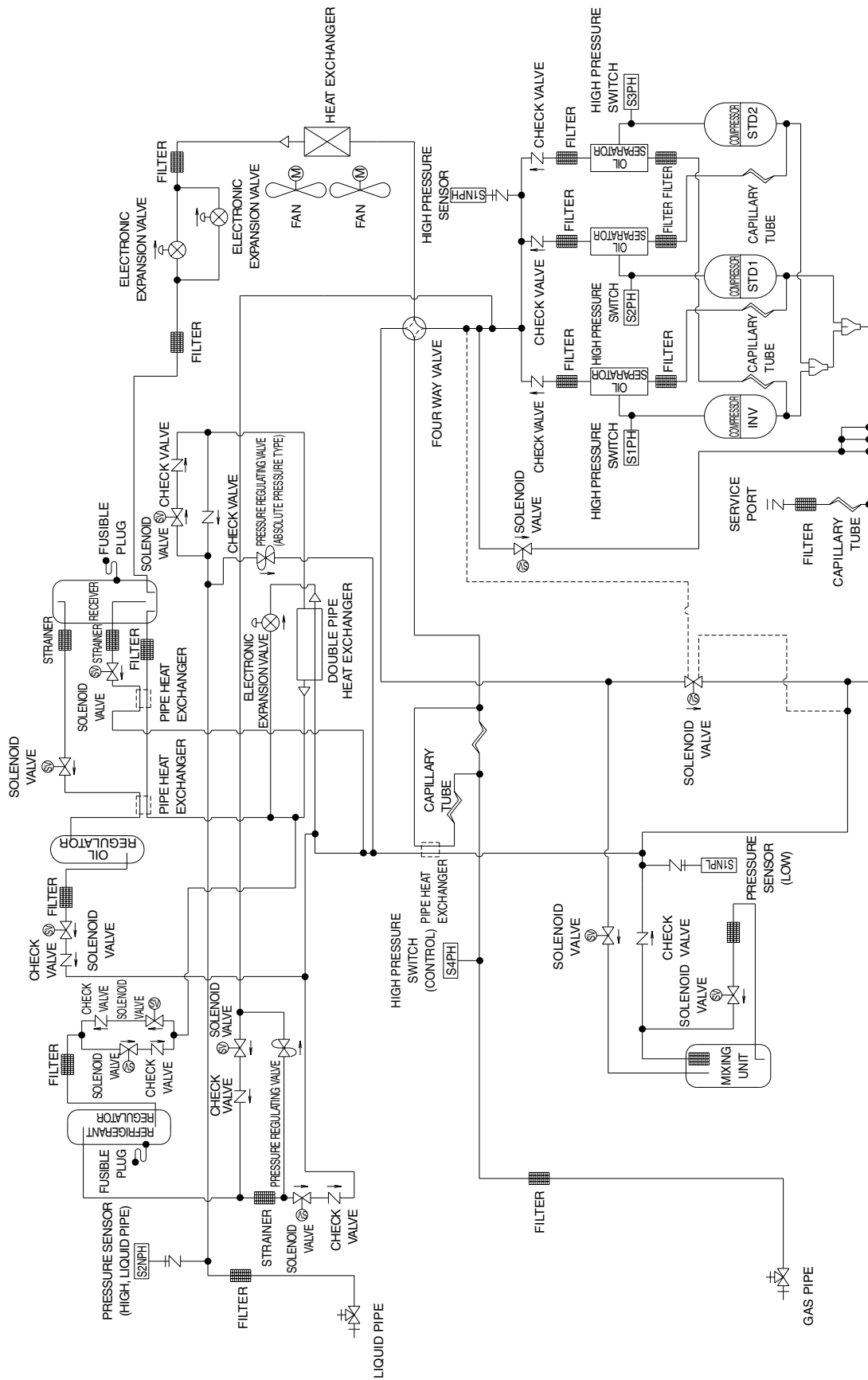

3D069110A

RQYQ10PY1B / RQYQ12PY1B

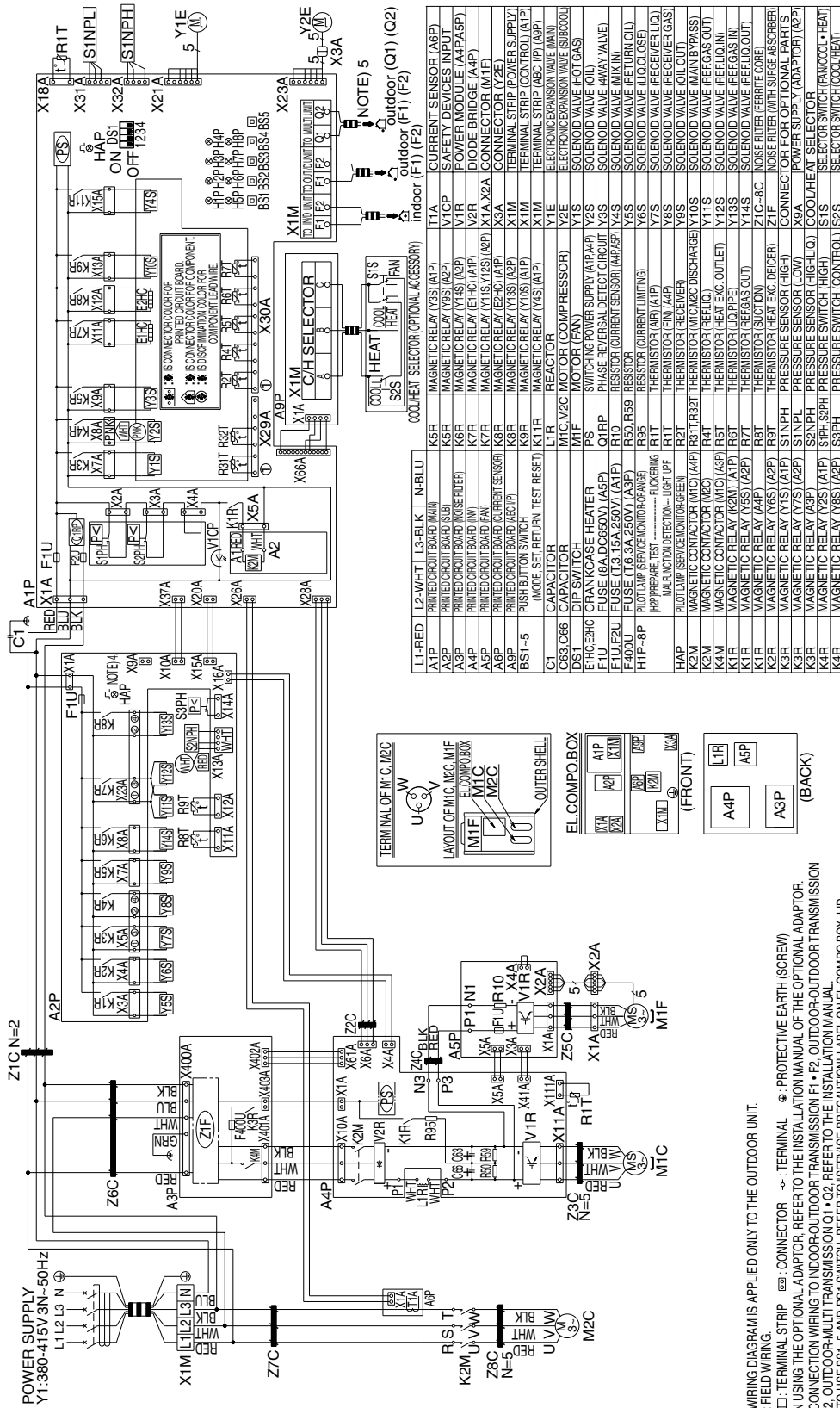

L1-RED	L2-WHT	L3-BLK	N-BLU	A1P	PRINTED CIRCUIT BOARD (MAIN)
A2P	PRINTED CIRCUIT BOARD (SUB)	A3P	PRINTED CIRCUIT BOARD (MISC-FUSE)	A4P	PRINTED CIRCUIT BOARD (MISC-FUSE)
A5P	PRINTED CIRCUIT BOARD (FAN)	A6P	PRINTED CIRCUIT BOARD (CURRENT SENSOR)	A9P	PRINTED CIRCUIT BOARD (ARC I/P)
BS1-5	PUSH-BUTTON SWITCH (MODE SET, RETURN, TEST, RESET)	C1	CAPACITOR	C63, C66	DIP SWITCH
DS1	EHC/E2HC CRANKCASE HEATER	F1U	FUSE (6A, DC650V) (A5P)	F1U, F2U	FUSE (T.3.15A, 250V) (A1P)
F400U	FUSE (T.6.3A, 250V) (A3P)	H1P-8P	PILOT LAMP (SERVICE MONITOR-ORANGE)	H1P	PILOT LAMP (SERVICE MONITOR-ORANGE)
HAP	WALNUT DETECTION - LIGHT I/P	K2M	MAGNETIC CONTACTOR (M1C) (M2C) (M3C) (DISCHARGE)	R31T, R32T	THERMISTOR (RECEIVER)
K2M	MAGNETIC CONTACTOR (M2C)	K4M	MAGNETIC CONTACTOR (M1C) (M3P)	R51	THERMISTOR (HEAD EXC. OUTLET)
K1R	MAGNETIC RELAY (Y2M) (A1P)	R61	THERMISTOR (HEAD EXC. OUTLET)	K1R	MAGNETIC RELAY (Y2M) (A2P)
K1R	MAGNETIC RELAY (A3P)	R61	THERMISTOR (HEAD EXC. OUTLET)	K2R	MAGNETIC RELAY (Y6S) (A1P)
K2R	MAGNETIC RELAY (Y6S) (A2P)	R91	THERMISTOR (HEAD EXC. BEIGER)	K3R	MAGNETIC RELAY (Y1S) (A1P)
K3R	MAGNETIC RELAY (Y1S) (A2P)	S1NPH	PRESSURE SENSOR (HIGH)	K3R	MAGNETIC RELAY (Y3P) (A2P)
K4R	MAGNETIC RELAY (Y2S) (A1P)	S2NPH	PRESSURE SENSOR (HIGH LIQ.)	K4R	MAGNETIC RELAY (Y8S) (A2P)
K4R	MAGNETIC RELAY (Y8S) (A2P)	S3P	PRESSURE SWITCH (CONTROL)	S2S	SELECTOR SWITCH (COOL/HEAT)
K5R	MAGNETIC RELAY (Y3S) (A1P)	T1A	CURRENT SENSOR (A6P)	V1R	SOLENOID VALVE (HOT GAS)
K5R	MAGNETIC RELAY (Y5S) (A2P)	V1R	SOLENOID VALVE (HOT GAS)	V2R	SOLENOID VALVE (HOT GAS)
K6R	MAGNETIC RELAY (Y4S) (A2P)	V2R	SOLENOID VALVE (HOT GAS)	V3R	SOLENOID VALVE (HOT GAS)
K7R	MAGNETIC RELAY (Y1S) (Y2S) (A2P)	X2A	CONNECTOR (Y2E)	X2A	CONNECTOR (Y2E)
K8R	MAGNETIC RELAY (Y4H) (A1P)	X1M	TERMINAL STRIP (POWER SUPPLY)	X1M	TERMINAL STRIP (CONTROL) (A1P)
K9R	MAGNETIC RELAY (Y1S) (A2P)	X1M	TERMINAL STRIP (CONTROL) (A1P)	X1M	TERMINAL STRIP (ARC I/P) (A6P)
L1R	MAGNETIC RELAY (Y1S) (A1P)	Y1E	ELECTRONIC EXPANSION VALVE (MAIN)	Y1E	ELECTRONIC EXPANSION VALVE (SUBCOOL)
M1C	MOTOR (FAN)	Y1S	SOLENOID VALVE (HOT GAS)	Y2S	SOLENOID VALVE (HOT GAS)
PS	SWITCHING POWER SUPPLY (A1P/A6P)	Y3S	SOLENOID VALVE (HOT GAS)	Y3S	SOLENOID VALVE (HOT GAS)
QTRP	PHASE REVERSAL DETECT CIRCUIT	Y4S	SOLENOID VALVE (MIX IN)	Y4S	SOLENOID VALVE (MIX IN)
R10	FUSE (T.3.15A, 250V) (A1P)	Y5S	SOLENOID VALVE (RETURN OIL)	Y5S	SOLENOID VALVE (RETURN OIL)
R50, R59	RESISTOR	Y6S	SOLENOID VALVE (LOC. CLOSE)	Y6S	SOLENOID VALVE (LOC. CLOSE)
R95	RESISTOR (CURRENT LIMITING)	Y7S	SOLENOID VALVE (RECEIVER GAS)	Y7S	SOLENOID VALVE (RECEIVER GAS)
R21	THERMISTOR (AIR I/P)	Y8S	SOLENOID VALVE (RECEIVER GAS)	Y8S	SOLENOID VALVE (RECEIVER GAS)
R22	THERMISTOR (FIN I/P)	Y10S	SOLENOID VALVE (MAIN BYPASS)	Y10S	SOLENOID VALVE (MAIN BYPASS)
R31T, R32T	THERMISTOR (M1C, M2C, DISCHARGE)	Y11S	SOLENOID VALVE (REF. GAS OUT)	Y11S	SOLENOID VALVE (REF. GAS OUT)
R41	THERMISTOR (REF. LIQ.)	Y12S	SOLENOID VALVE (REF. GAS IN)	Y12S	SOLENOID VALVE (REF. GAS IN)
R51	THERMISTOR (HEAD EXC. OUTLET)	Y13S	SOLENOID VALVE (REF. GAS IN)	Y13S	SOLENOID VALVE (REF. GAS IN)
R61	THERMISTOR (HEAD EXC. OUTLET)	Y16	SOLENOID VALVE (LOC. OUT)	Y16	SOLENOID VALVE (LOC. OUT)
R61	THERMISTOR (HEAD EXC. OUTLET)	Z1E	NOISE FILTER WITH SURGE ABSORBER	Z1E	NOISE FILTER WITH SURGE ABSORBER
R91	THERMISTOR (HEAD EXC. BEIGER)	X9A	CONNECTOR FOR OPTIONAL PARTS	X9A	CONNECTOR FOR OPTIONAL PARTS
S1NPH	PRESSURE SENSOR (HIGH)	X1M	TERMINAL STRIP (CONTROL) (A1P)	X1M	TERMINAL STRIP (CONTROL) (A1P)
S2NPH	PRESSURE SENSOR (HIGH LIQ.)	X1M	TERMINAL STRIP (CONTROL) (A1P)	X1M	TERMINAL STRIP (CONTROL) (A1P)
S3P	PRESSURE SWITCH (CONTROL)	X1M	TERMINAL STRIP (CONTROL) (A1P)	X1M	TERMINAL STRIP (CONTROL) (A1P)
S2S	SELECTOR SWITCH (COOL/HEAT)	X1M	TERMINAL STRIP (CONTROL) (A1P)	X1M	TERMINAL STRIP (CONTROL) (A1P)

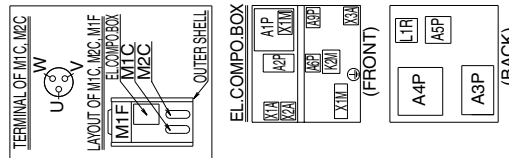

- NOTES
1. THIS WIRING DIAGRAM IS APPLIED ONLY TO THE OUTDOOR UNIT.
 2. : TERMINAL STRIP
 3. : TERMINAL STRIP
 4. WHEN USING THE OPTIONAL ADAPTOR, REFER TO THE INSTALLATION MANUAL OF THE OPTIONAL ADAPTOR.
 5. FOR CONNECTION WIRING TO INDOOR/OUTDOOR TRANSMISSION F1, F2, OUTDOOR/OUTDOOR TRANSMISSION F1, F2, OUTDOOR/MULTI TRANSMISSION G1, G2, REFER TO THE INSTALLATION MANUAL.
 6. HOW TO USE BS1-5 AND DS1 SWITCH, REFER TO "SERVICE PRECAUTION" LABEL ON EL COMPO BOX, LID.
 7. WHEN OPERATING, DON'T SHORT-CIRCUIT THE PROTECTION DEVICE (SPH, SPPH).
 8. COLORS BLK: BLACK RED: RED BLU: BLUE WHT: WHITE PNK: PINK YLW: YELLOW BRN: BROWN GRN: GREEN ORG: ORANGE.

RQYQ14PY1B / RQYQ16PY1B

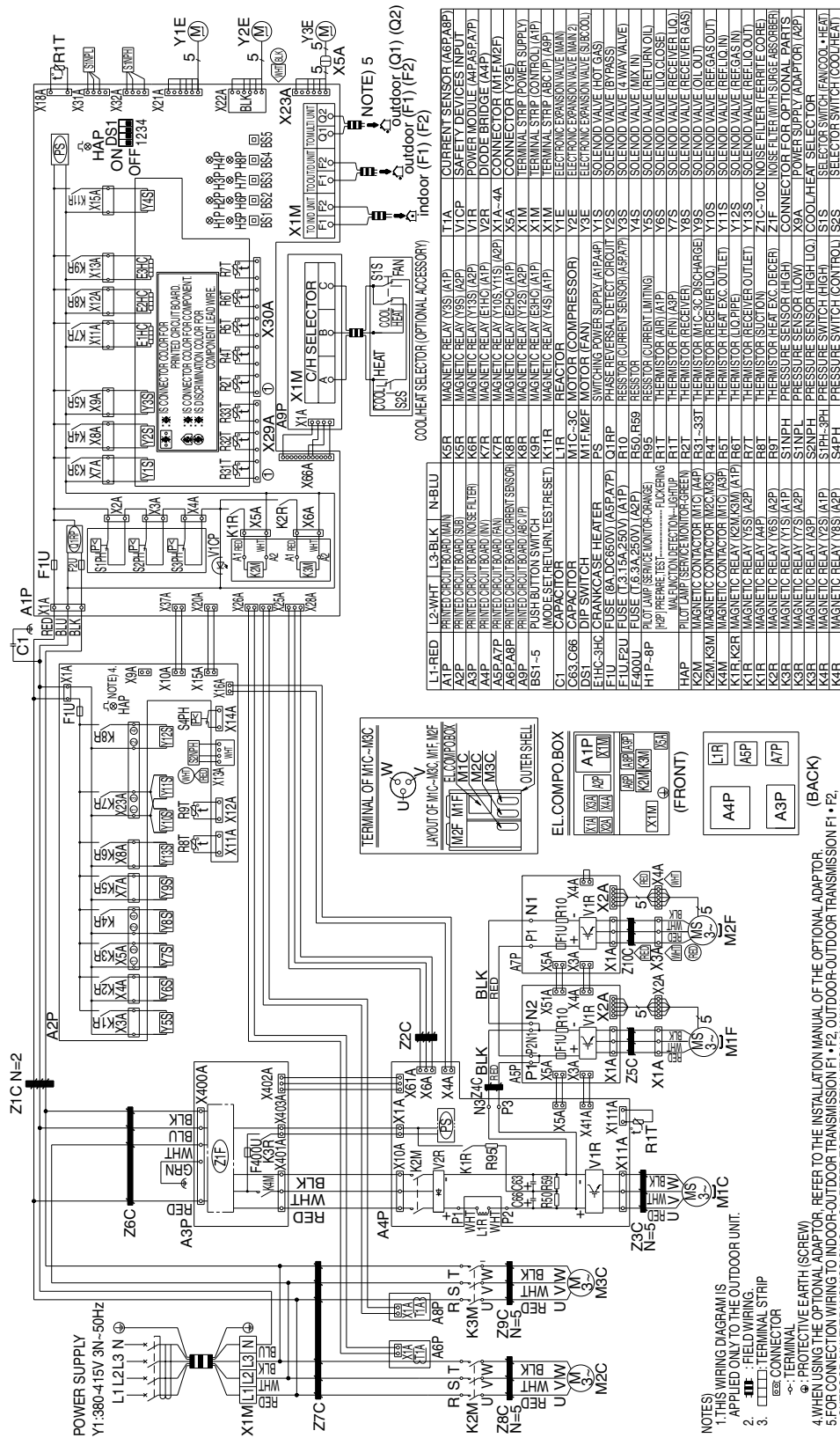

3. Accessories

3.1 Optional Accessories

Series		VRV III		
Model	RQYQ8PY1B RQYQ10PY1B RQYQ12PY1B	RQYQ14PY1B RQYQ16PY1B	RQYQ18PY1B RQYQ20PY1B RQYQ22PY1B	
Option name				
Cool/Heat selector	KRC19-26A			
Fixing box	KJB111A			
Distributive piping	REFNET header	KHRP26M22H(Max. 4 branch) KHRP26M33H(Max. 8 branch)	KHRP26M22H(Max. 4 branch), KHRP26M33H(Max. 8 branch) KHRP26M72H(Max. 8 branch)	
	REFNET joint	KHRP26A22T,KHRP26A33T	KHRP26A22T,KHRP26A33T,KHRP26A72T	
Pipe size reducer				
Outdoor unit multi connection piping kit				BHFP22P100
Digital pressure gauge kit	BHGP26A1			BHGP26A1x2
Central drain pan kit	KWC26C280	KWC26C450	KWC26C280x2	

Series							
Model	RQYQ24PY1B	RQYQ26PY1B RQYQ28PY1B	RQYQ30PY1B RQYQ32PY1B	RQYQ34PY1B RQYQ36PY1B RQYQ38PY1B RQYQ40PY1B	RQYQ42PY1B RQYQ44PY1B	RQYQ46PY1B RQYQ48PY1B	
Option name							
Cool/Heat selector	KRC19-26A						
Fixing box	KJB111A						
Distributive piping	REFNET header	KHRP26M22H(Max. 4 branch), KHRP26M33H(Max. 8 branch) KHRP26M72H(Max. 8 branch),KHRP26M73H(Max. 8 branch)					
	REFNET joint	KHRP26A22T,KHRP26A33T,KHRP26A72T,KHRP26A73T					
Pipe size reducer	KHRP26M73TP,KHRP26M73HP						
Outdoor unit multi connection piping kit	BHFP22P100			BHFP22P151			
Digital pressure gauge kit	BHGP26A1x2			BHGP26A1x3			
Central drain pan kit	KWC26C280x2	KWC26C280 KWC26C450	KWC26C450x2	KWC26C280x2 KWC26C450	KWC26C280 KWC26C450x2	KWC26C450x3	

3D069186A

Warning



- Daikin products are manufactured for export to numerous countries throughout the world. Prior to purchase, please confirm with your local authorised importer, distributor and/or retailer whether this product conforms to the applicable standards, and is suitable for use, in the region where the product will be used. This statement does not purport to exclude, restrict or modify the application of any local legislation.
- Ask a qualified installer or contractor to install this product. Do not try to install the product yourself. Improper installation can result in water or refrigerant leakage, electrical shock, fire or explosion.
- Use only those parts and accessories supplied or specified by Daikin. Ask a qualified installer or contractor to install those parts and accessories. Use of unauthorised parts and accessories or improper installation of parts and accessories can result in water or refrigerant leakage, electrical shock, fire or explosion.
- Read the User's Manual carefully before using this product. The User's Manual provides important safety instructions and warnings. Be sure to follow these instructions and warnings.

If you have any enquiries, please contact your local importer, distributor and/or retailer.

Cautions on product corrosion

1. Air conditioners should not be installed in areas where corrosive gases, such as acid gas or alkaline gas, are produced.
2. If the outdoor unit is to be installed close to the sea shore, direct exposure to the sea breeze should be avoided. If you need to install the outdoor unit close to the sea shore, contact your local distributor.



JMI-0107

Organization:
DAIKIN INDUSTRIES, LTD.
AIR CONDITIONING MANUFACTURING DIVISION

Scope of Registration:
THE DESIGN/DEVELOPMENT AND MANUFACTURE OF
COMMERCIAL AIR CONDITIONING, HEATING, COOLING,
REFRIGERATING EQUIPMENT, COMMERCIAL HEATING
EQUIPMENT, RESIDENTIAL AIR CONDITIONING
EQUIPMENT, HEAT RECLAIM VENTILATION, AIR
CLEANING EQUIPMENT, MARINE TYPE CONTAINER
REFRIGERATION UNITS, COMPRESSORS AND VALVES.



JQA-1452

Organization:
DAIKIN INDUSTRIES
(THAILAND) LTD.

Scope of Registration:
THE DESIGN/DEVELOPMENT
AND MANUFACTURE OF AIR
CONDITIONERS AND THE
COMPONENTS INCLUDING
COMPRESSORS USED FOR THEM



EC99J2044

All of the Daikin Group's business facilities and subsidiaries in Japan are certified under the ISO 14001 international standard for environment management.

Dealer

DAIKIN INDUSTRIES, LTD.

Head Office:
Umeda Center Bldg., 2-4-12, Nakazaki-Nishi,
Kita-ku, Osaka, 530-8323 Japan

Tokyo Office:
JR Shinagawa East Bldg., 2-18-1, Konan,
Minato-ku, Tokyo, 108-0075 Japan

http://www.daikin.com/global_ac/

©All rights reserved