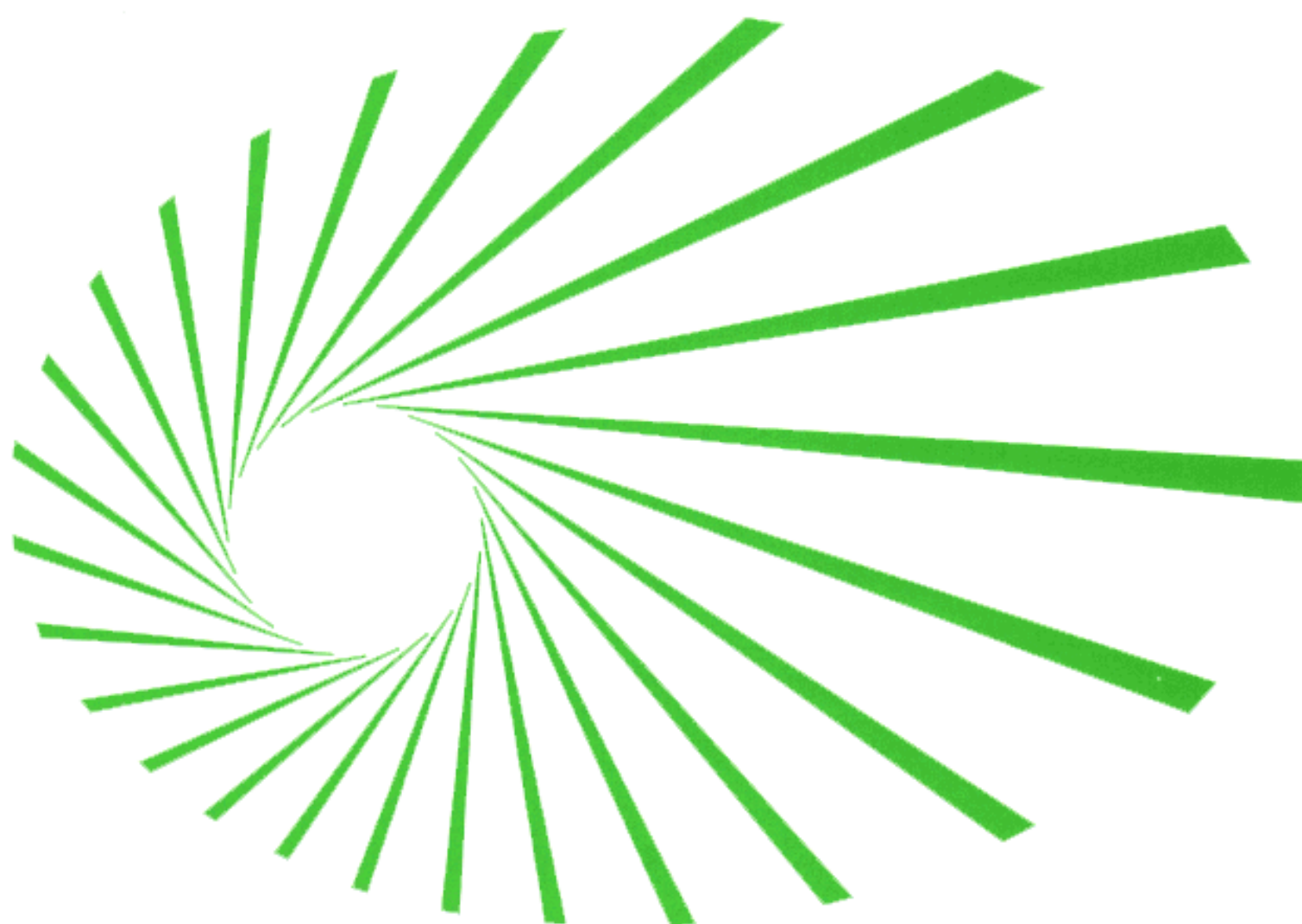


# Option Handbook



**Split E(A),F Series**  
**Multi E(A) Series**  
**Sky Air F Series**

# CONTENTS

## 1. SPLIT-E(A), F/MULTI-E(A) Series

### Indoor Unit

- 1 Centralized control board –up to 5 rooms– .....1  
KRC72
- 2 Wiring adaptor for Time clock / Remote control .....4  
(Normal open pulse contact)  
KRP411A1S < For FT25E(A), F · 35E(A) >  
KRC73 < For FT45E(A) · 60E(A), FV45C · 60C, FT-31B >
- 3 Wiring adaptor for Time clock / Remote control .....8  
(Normal open contact)  
KRP410A11S < For FT25E(A), F · 35E(A) >  
KRC74 < For FT45E(A) · 60E(A), FV45C · 60C, FT-31B >
- 4 Air purifying filter with frame .....12  
KAF492A1 < For FT25, 35E(A) >  
KAF96A41 < For FT25F >
- 5 Air purifying filter without frame .....13  
KAF492A2 < For FT25, 35E(A) >  
KAF96A42 < For FT25F >
- 6 Anti-theft protection for wireless remote controller .....14  
KKF713A

### Outdoor Unit

- 1 Drain piping kit.....14  
KIS95

## 2. SKY AIR-F Series

### Indoor Unit

- 1 Remote Controller .....15
  - 1.1 Wired type BRC1B61 < For FH(Y)C-F, FH(Y)K-F, FHY-F, FA(Y)-F >  
BRC1B62 < For FH(Y)B-F, FH-F >
  - 1.2 Wireless type BRC7A61W < For FHYC-F > .....Heat Pump  
BRC7A66W < For FH(Y)C-F > ...Cooling only  
BRC7A64W < For FAY-F > .....Heat Pump  
BRC7A69W < For FA(Y)-F > .....Cooling only

<b>2</b>	<b>Central Remote Controller .....</b>	<b>64</b>
	DCS302B61	
<b>3</b>	<b>Unified ON/OFF Controller .....</b>	<b>90</b>
	DCS301B61	
<b>4</b>	<b>Schedule timer .....</b>	<b>98</b>
	DST301B61	
<b>5</b>	<b>Adaptor for wiring .....</b>	<b>109</b>
	KRP1B51 · 54 · 56 · 57	
<b>6</b>	<b>Wiring adaptor for electrical appendices.....</b>	<b>112</b>
	KRP4A51 · 52 · 53 · 54	
<b>7</b>	<b>Interface adaptor for Sky Air Series .....</b>	<b>120</b>
	DTA102A52	
<b>8</b>	<b>Ceiling mounted cassette type [FH(Y)C] .....</b>	<b>123</b>
	8.1 Decoration panel	
	BYC71F-W1 · 125F-W1	
	8.2 Sealing member of air discharge outlet	
	KDBHJ55F80 · 160	
	8.3 Panel spacer	
	KDBJ55F80W · 160W	
	8.4 Air discharge grille	
	KAWJ55F80 · 160	
	KAWVJ55F80 · 160	
	8.5 Lifter style air suction grille	
	KDVJ55F80 · 160	
	8.6 Fresh air intake kit	
	KDDJ55F80 · 160	
	8.7 Sound absorption kit	
	KDDNJ55F80 · 160	
	8.8 High efficiency filter	
	KAFJ552F80 · 160, KAFJ553F80 · 160	
	KDDFJ55F80 · 160 (Filter chamber)	
	8.9 Replacement long-life filter	
	KAFJ551F80 · 160	
	KAFJ550F80 · 160	
	8.10 Installation box for adaptor PCB	
	KRP1B94	

- 8.11 Optional kit installation drawing
  - High efficiency filter
  - Fresh air intake kit (without duct fan)
  - Sound absorption kit
  - Lifter style suction grille
  - Panel spacer

**9 Ceiling mounted cassette corner type [FH(Y)K] .....158**

- 9.1 Decoration panel
  - BYK45FJW1 · 71FJW1
- 9.2 Panel spacer
  - KPBJ52F56W · 80W
- 9.3 Air discharge blind panel
  - KDBJ52F56W · 80W
- 9.4 Replacement long-life filter
  - KAFJ521F56 · 80
- 9.5 Discharge grille
  - KDGJ52F56W · 80W
- 9.6 Flexible duct with shutter
  - KFDJ52F56 · 80
- 9.7 Optional kit installation drawing
  - Panel spacer
  - Air discharge blind panel, Discharge grille and Flexible duct

**10 Ceiling mounted built-in type [FH(Y)B] .....185**

- 10.1 Decoration panel
  - BYBS45D-W2 · 71D-W2 · 125D-W2
- 10.2 Service access panel
  - KTBJ25K56W · 80W · 160W
- 10.3 High-efficiency filter
  - KAFJ252K56 · 80 · 160
  - KAFJ253K56 · 80 · 160
- 10.4 Replacement long-life filter
  - KAFJ251K56 · 80 · 160
- 10.5 Filter chamber for bottom suction
  - KAJ25K56D · 80D · 160D
- 10.6 Filter chamber for rear suction
  - KAJ25K56B · 80B · 160B
- 10.7 Canvas duct
  - KSAJ25K56 · 80 · 160

10.8 Air discharge unit—Discharge grille+{Discharge chamber  
KDG90D4-1W · D5-1W · D7-1W · D9-1W · B4-2 · B5-2 · B7-2 · B9-2

10.9 Branch duct  
KHA90B1

10.10 Flexible duct  
KFD90A151H · 152H  
KFD56A1H · 2H

10.11 Blind board  
KBBJ25K56 · 80 · 160

10.12 Flange for suction  
KDJ2507K56 · 80 · 160

10.13 Adaptor for discharge  
KDAJ25K56 · 71 · 140

**11 Ceiling suspended type [FH(Y)] .....200**

11.1 Drain pump kit (For 60Hz only)  
KDUJ5F50 · 80 · 160

11.2 Replacement long life filter  
KAFJ501F56 · 80 · 112 · 160

11.3 L-type piping kit (for upward direction)  
KHFJ5F50 · 60 · 80 · 160

11.4 Optional kit installation drawing  
Discharge grille+Discharge chamber <φ 150>  
Discharge grille+Discharge chamber <φ 200>

11.5 Installation box for adaptor PCB  
KRP1B93

**Outdoor Unit**

**1 Year-round cooling kit .....210**  
KRK5F80V1 · 140V1

**2 Central drain plug .....216**  
KKPJ5F180

**3 Fixture for preventing overturning.....217**  
KPTJ60F160

**4 Auxiliary piping .....218**  
KHFJ5F80F · 180F · 80B · 180B

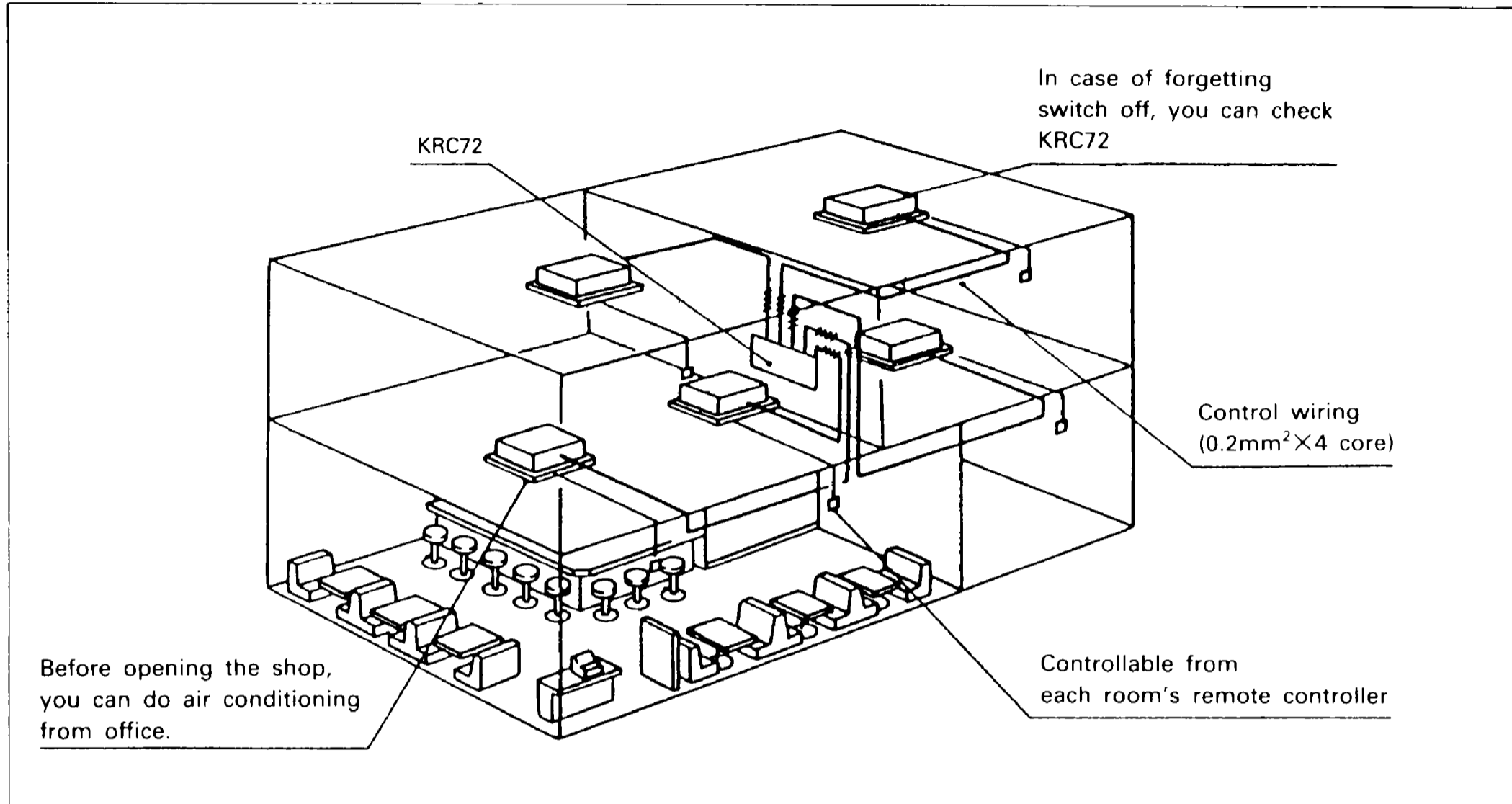
# 1. SPLIT-E(A), F/MULTI-E(A) Series

## Indoor Unit

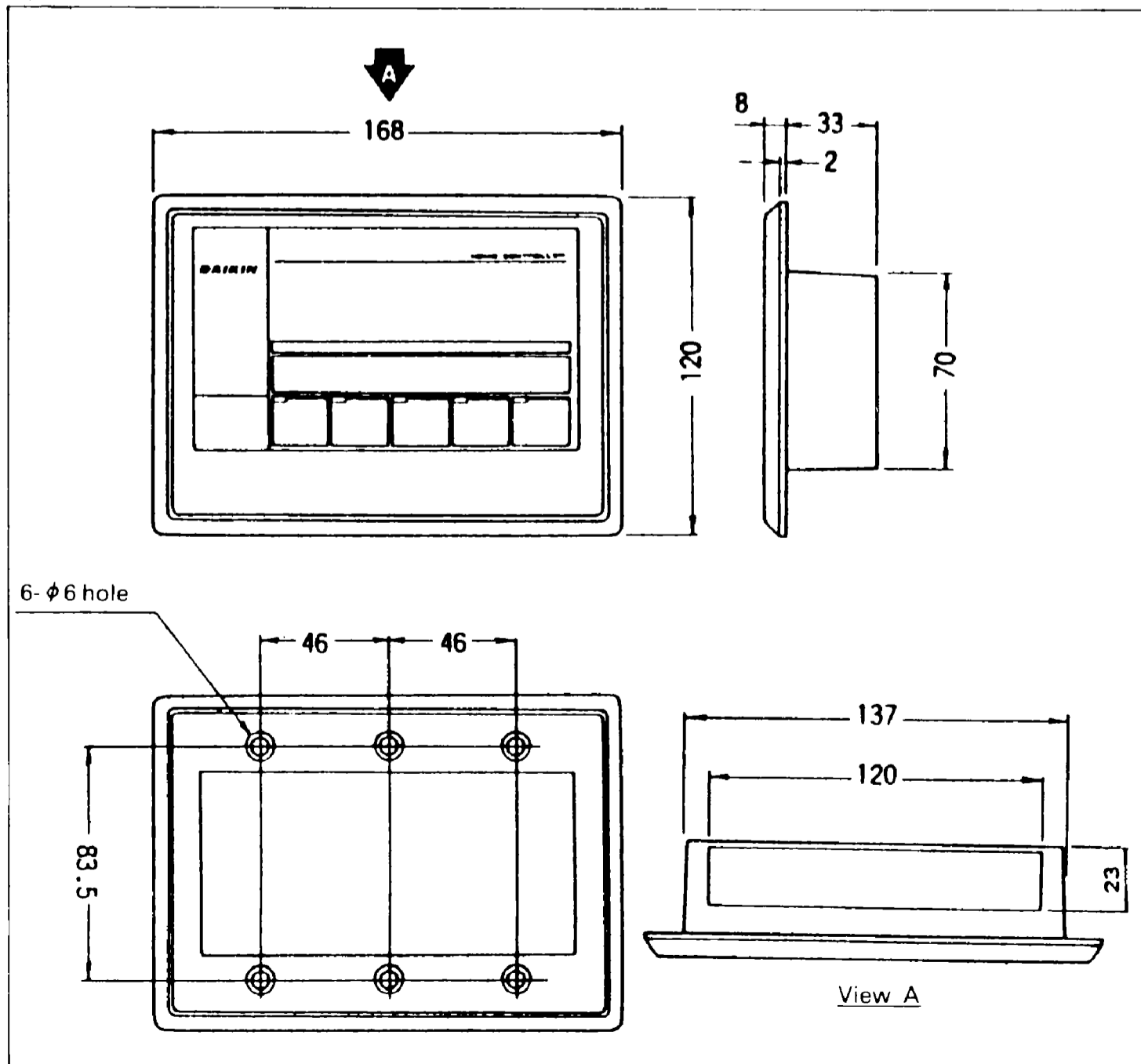
### 1 Centralized control board – up to 5 rooms –

#### KRC72

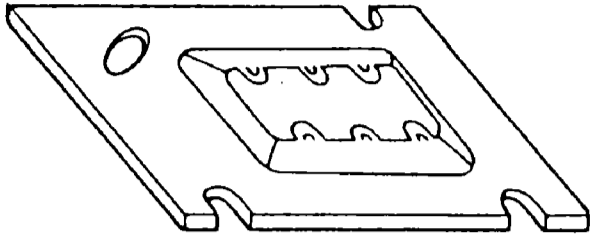
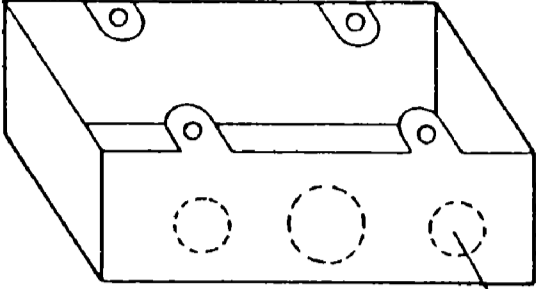
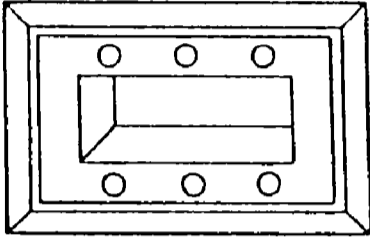
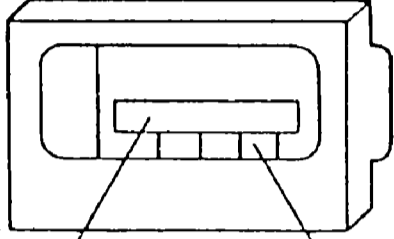
##### ① System application



##### 2 Dimensions



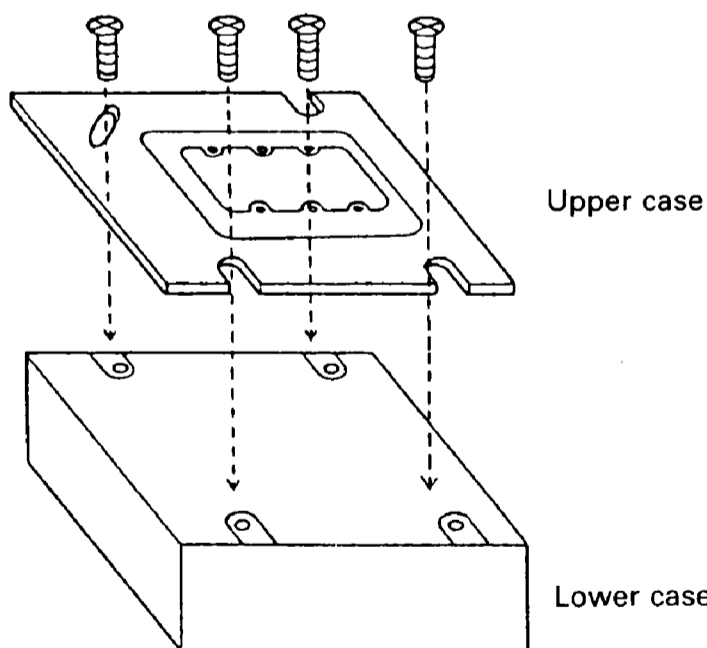
### ③ Parts of Components

<p>(1) Upper case of switch box 1 pc.</p> 	<p>(2) Lower case of switch box 1 pc.</p>  <p style="text-align: right;">K/O hole</p>
<p>(3) Lower case 1 pc.</p> 	<p>(4) Operation panel 1 pc. (KRC72)</p>  <p style="text-align: center;">"Cover for Face plate of Room name"</p> <p style="text-align: right;">A-Room</p>
<ul style="list-style-type: none"> <li>• Face plate of room name ..... 1 pc.</li> <li>• M4 Screw ..... 6 pcs.</li> </ul>	<ul style="list-style-type: none"> <li>• Screw for switch box ..... 4 pcs.</li> <li>• Manual (Description) ..... 1 copy</li> </ul>

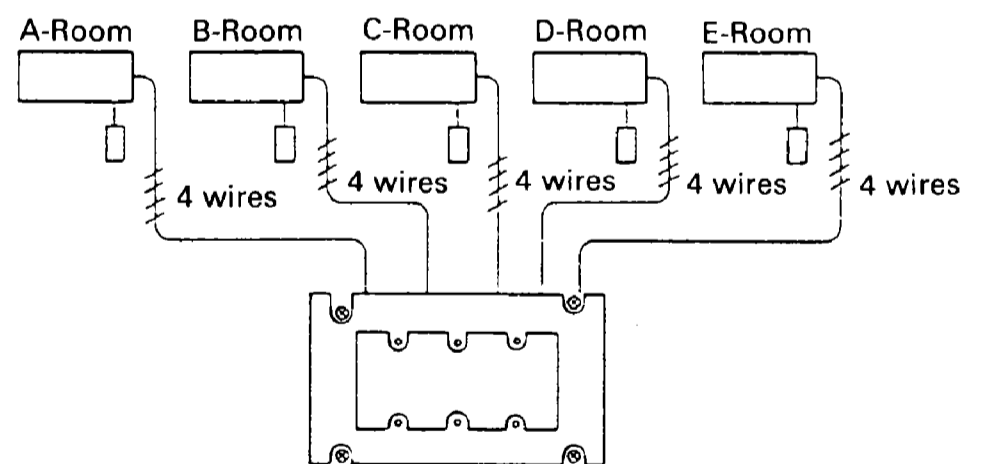
**Attention** When using this kit, please prepare the P-board (print circuit board) set of remote control (KRC73) of the same number as that of the air conditioners (indoor unit) to be controlled.

### ④ Procedures of the installation work

1) The upper case of the switch box shall be fixed on the lower case of the switch box with the screws.



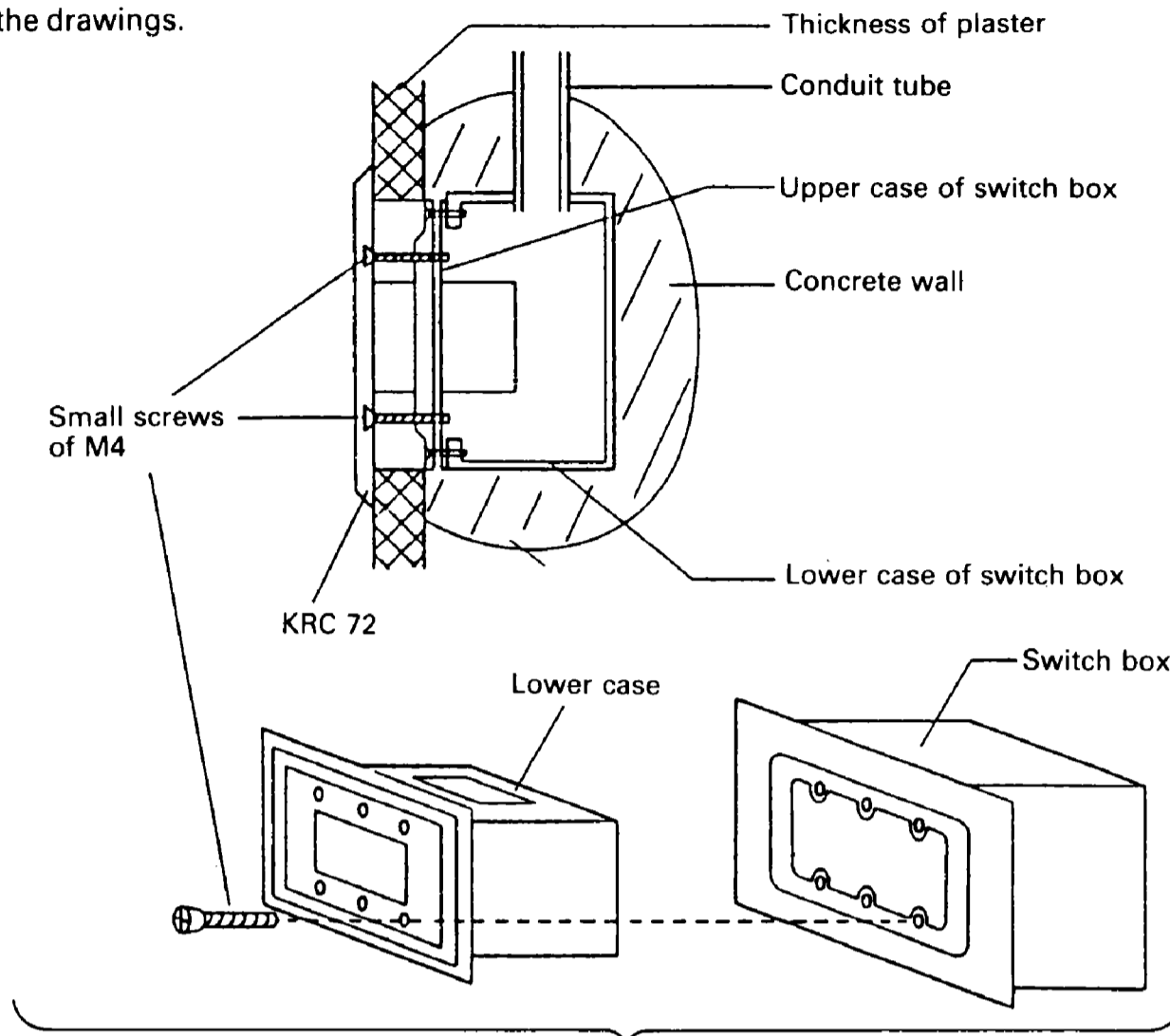
2) Previously, the switch box shall be set and the connection wires the each air conditioner shall be laid under the ground.



Note: Each  $///$  mark shows four wires.

When connecting the wire, please utilize the three of knockouts (K/O) respectively provide for each of upper and lower side of the lower case of the switch box.  
Also, or the connection wiring, four core cables with sheath of 0.15 to 0.3 mm<sup>2</sup> shall be applied. (Max.50m)

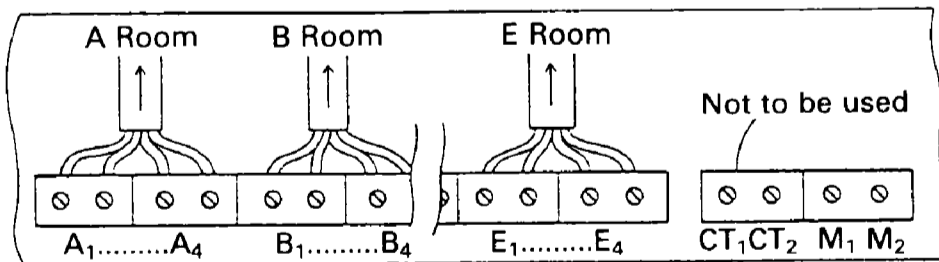
3) The laying and installing methods for the switch box and the home controller KRC 72 are shown in the following drawings. Please refer to the drawings.



Connecting method of KRC 72 lower case with the switch box.  
According to the drawing shown in the above, the M4 small screws shall be driven at the respective six holes of the case and box.

Here, the connecting wires shall be taken out to the lower case inside, before mounting the upper case into the lower case.

4) The connecting wires shall be respectively connected with the terminal blocks fixed at the back side of the P-board.  
(The switches of the operation panel are called as A to E rooms from the right side.)



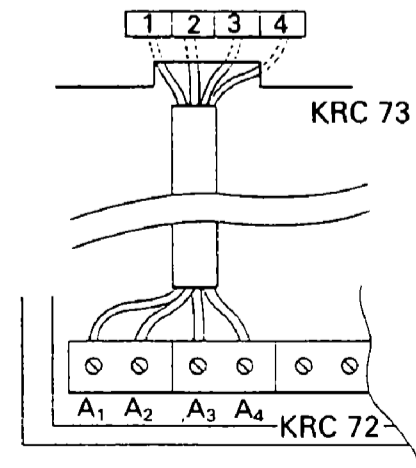
5) The operation panel shall be inserted into the lower case of KRC 72.

[Reference]

Re: Installation work in the air conditioner side.

The connecting wire shall be jointed to the P-board for remote control use of KRC 73.

At the time, the P-board terminal numbers of the operation panel (No.1 to No.4) shall be adjusted to the respective terminal Nos. of KRC 73. (Refer to the drawing below.)





## 2 Wiring adaptor for Time clock / Remote control (Normal open pulse contact)

**KRP411A1S** < For FT25E(A), F · 35E(A) >

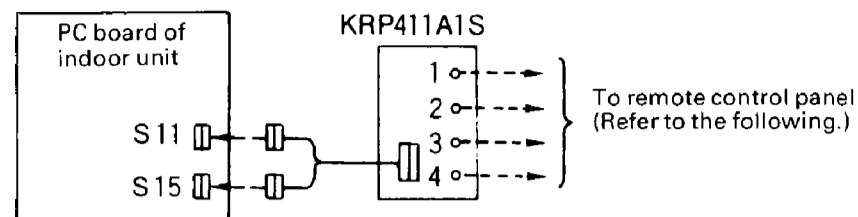
### < Specifications >

Item	Kit name	KRP411A1S
Control signal		No voltage, Normal open pulse contact
Operation control		By unit or Remote control panel, Priority to most recent command
Specification of contact		Pulse width of more than 200m sec.
Output of signal		Possible (only for LED)

### < Details of operation >

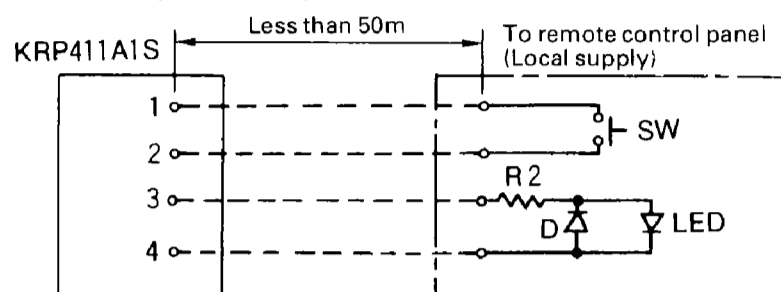
- Operation/Stop command by the remote controller for indoor unit or by the remote control panel has priority to the most recent command.
- The temperature setting, operation mode, air volume and etc. can be set by the remote controller for the indoor unit.

### < Connection with PC board of indoor unit >



### < Example of wiring >

Remote control by normal open pulse contact (KRP411A1S)



- The operation of the unit can be changed by depressing the switch.
- Pilot lamp of operation can not be installed. Make sure to use LED.

**KRC73** < For FT45E(A) · 60E(A), FV45C · 60C, FT-31B >

### ① Parts of Components

(1) Print board (1 pc.) (KRC64-3)	(2) Stopper for P-Board (4 pcs. of each of large and small)	(3) Tie-wrap (1 pc.)
	<div style="display: flex; justify-content: space-around;"> <div style="text-align: center;"> <p>(Large)</p> </div> <div style="text-align: center;"> <p>(Small)</p> </div> </div> <p>Large: for sky air use Small: for room air conditioning use</p>	
<p>* Manual: for sky air use ..... 1 copy for room air conditioning use ..... 1 copy</p>		

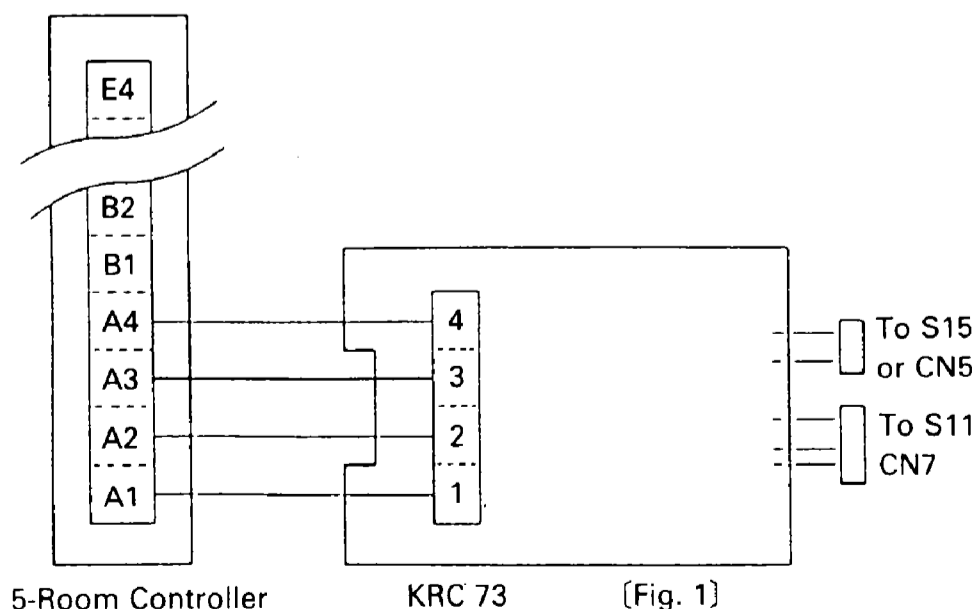
### ② Installation procedures

- 1) The connecting wire shall be connected with the terminal block of the print board (according to the connecting procedures shown in Fig.1).
- 2) The connector of the print board shall be connected with P-board of the main body.  
Nos. of the connector to be connected is:  
Room airconditioner ..... S<sub>11</sub> and S<sub>15</sub>  
Sky air ..... CN5 and CN7
- 3) When the connection work is completed, the print board shall be stored in the specified position of the airconditioner.

### ③ Connecting wiring

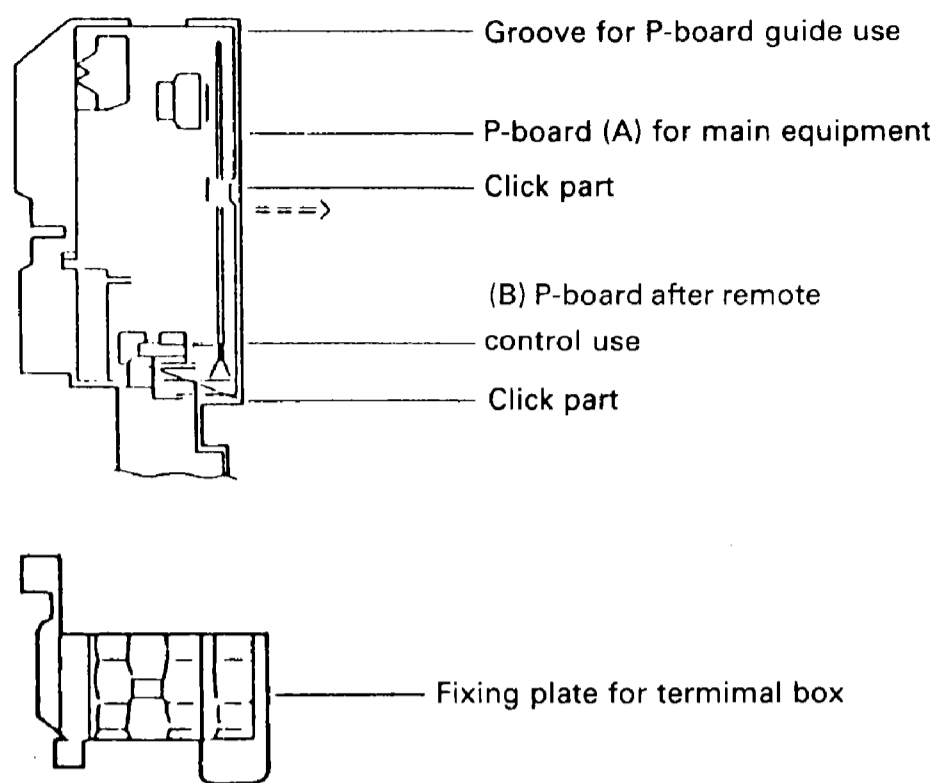
The cables for connection wiring shall be applied according to the following specification.

Four core cables with sheath of 0.15 to 0.3 mm<sup>2</sup>.



Note: The system can be applied for maximum five rooms from A to E in the five-room controller side.

**(1) Wall mounted type FT25E(A), FTY22/223A**

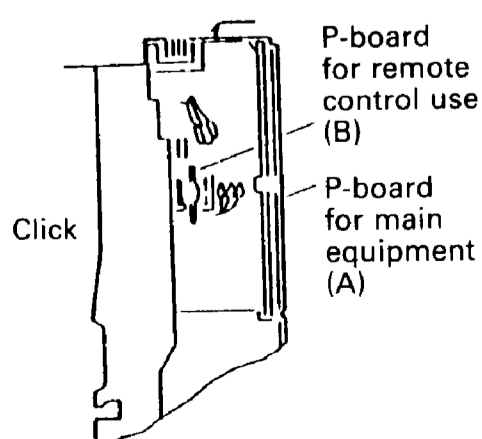


[Fig. 2]

- 1) The fixing plate for the terminal board shall be removed.
- 2) The connection wires shall be connected with the terminal block of P-board (B).
- 3) After drawing out the P-board by drawing the click part in the allow direction, the connector of P-board (B) shall be connected with  $S_{11}$  and  $S_{15}$ .
- 4) P-board (A) of the main equipment shall be stored as before. (After inserting the P-board into the groove parts of the left, right and lower sides, the board shall be inserted into the groove of the click part.)
- 5) As shown in the upper drawing, the P-board of (B) shall be inserted by putting the terminal block in the upper and front side. (After inserting the P-board into the groove parts of the left and lower sides, the board shall be inserted into the groove of the click part.)
- 6) The fixing plate of the terminal board shall be installed as it was before.

**(2) Wall mounted type FT35, 45E(A), FTY35/353A**

- 1) The connection wires shall be connected with the terminal block of P-board (B).
- 2) After drawing out the P-board by drawing the click part in the allow direction, the connector of P-board (B) shall be connected with  $S_{11}$  and  $S_{15}$ .
- 3) P-board (A) of the main equipment shall be stored as before. (After inserting the P-board into the groove parts of the left, right and lower sides, the board shall be inserted into the groove of the upper click part.)



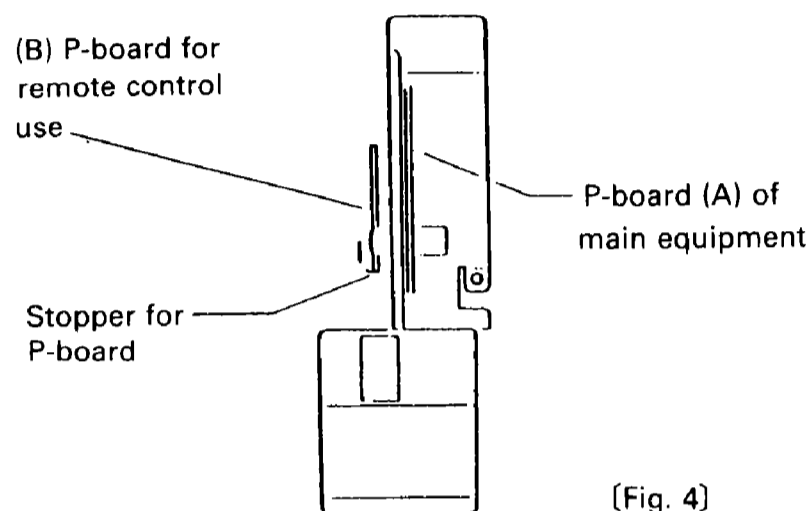
[Fig. 3]

- 4) As shown in the upper drawing, the P-board of (B) shall be inserted by putting the terminal block in the upper and front side.

(After inserting the P-board into the groove parts of the left and lower sides, the board shall be inserted into the groove of the click part.)

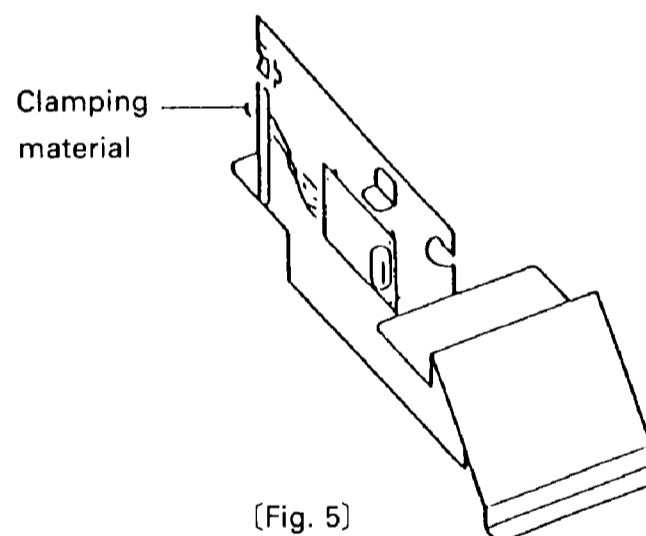
Note: In case of the equipment with heater, the work shall be made easy by disconnecting the plug connection. After the work, it shall be connected as it was before.

**(3) FT60E(A), FTY45/60A and FTY453/603A**



[Fig. 4]

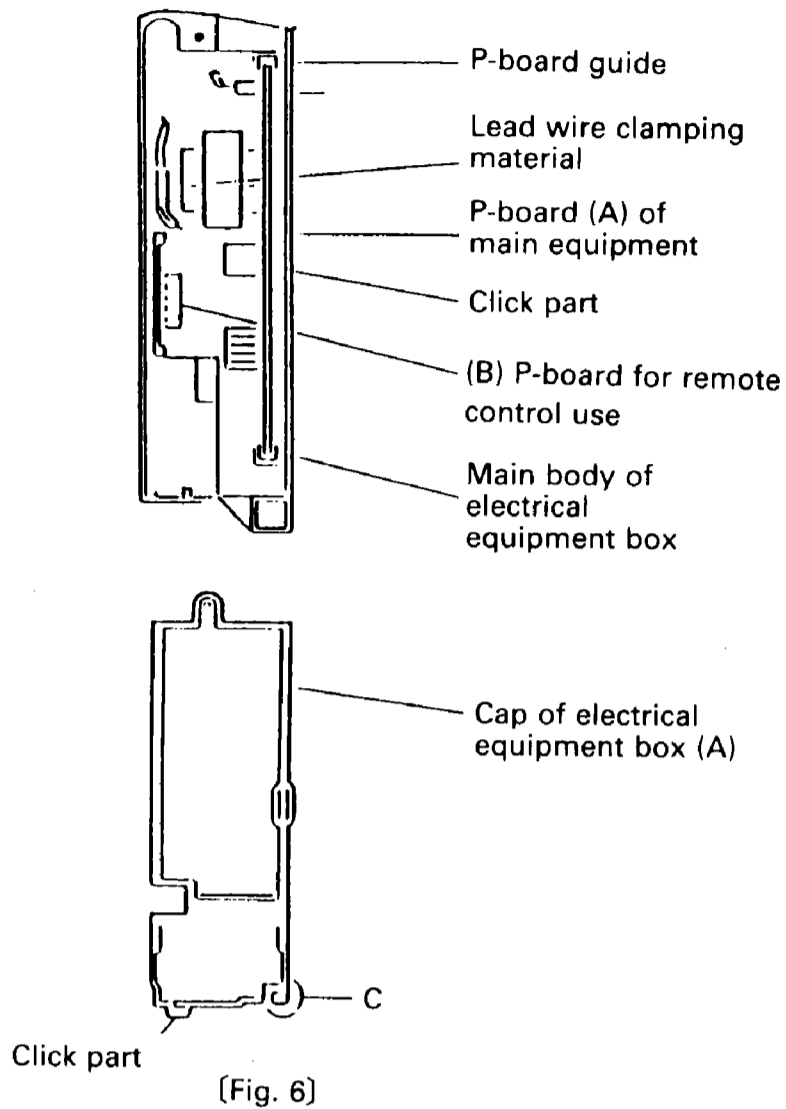
- 1) The connector of P-board (B) shall be connected with  $S_{11}$  and  $S_{15}$  of the P-board (A) of the main equipment.
- 2) The connection wires shall be connected with the terminal block of the P-board (B).



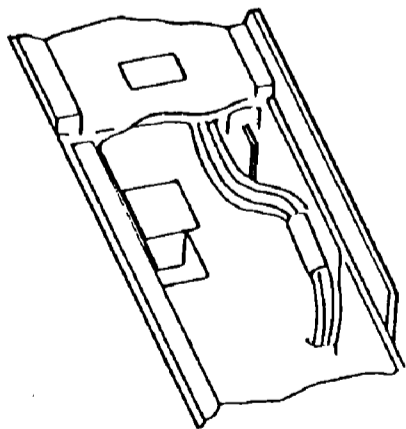
[Fig. 5]

- 3) The P-board (B) shall be installed with the stopper of the P-board on to the electrical equipment box.
- 4) The lead wire from the P-board shall be banded with clamping material at the same position as that of the thermistor lead wire. (Fig.4) , (Fig.5)

**(4) Floor mounted type FV45, 60, FVY22/35/45A**



- 1) The cap of the electrical equipment box (A) shall be removed. (After removing one upper part screw, the click part of the main box of the electrical box shall be pushed to inside to slide the box upward.)
- 2) The connection wires shall be connected with the terminal block of the P-board (B).
- 3) After drawing out the P-board (A), the connector of P-board (B) shall be connected with S<sub>11</sub> and S<sub>15</sub>. (When drawing out the P-board (A), S<sub>10</sub> shall be removed, and then, the wire harness shall be removed from the clamping material of the lead wire.)
- 4) P-board (A) of the main equipment shall be stored as before. The P-board (A) shall be inserted into the P-board guide.



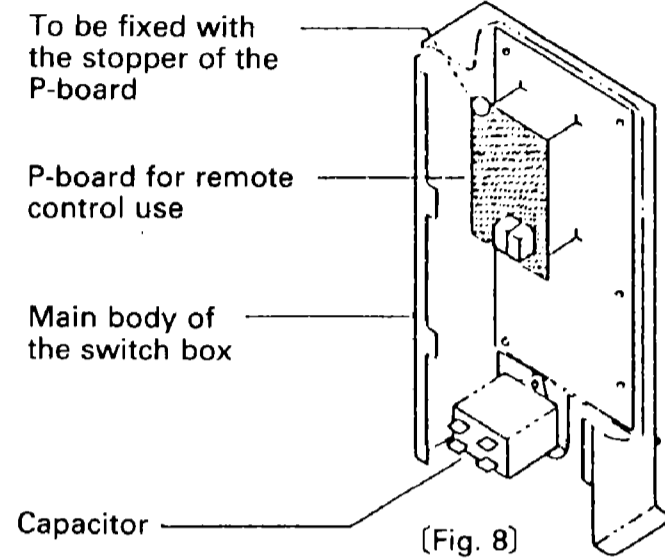
- 5) As shown in Fig.6 the P-board of (B) shall be inserted by putting the terminal block in the front side. (The P-board shall be inserted into the hollow part of the upper and lower grooves.)
- 6) The cap of electrical equipment box (A) shall be installed as it was before. (After inserting the click part of the cap of the electrical equipment box (A) into the hook part of the box, the screw of the upper part shall be tightened.

Note: The lead wire of the room temperature thermistor shall

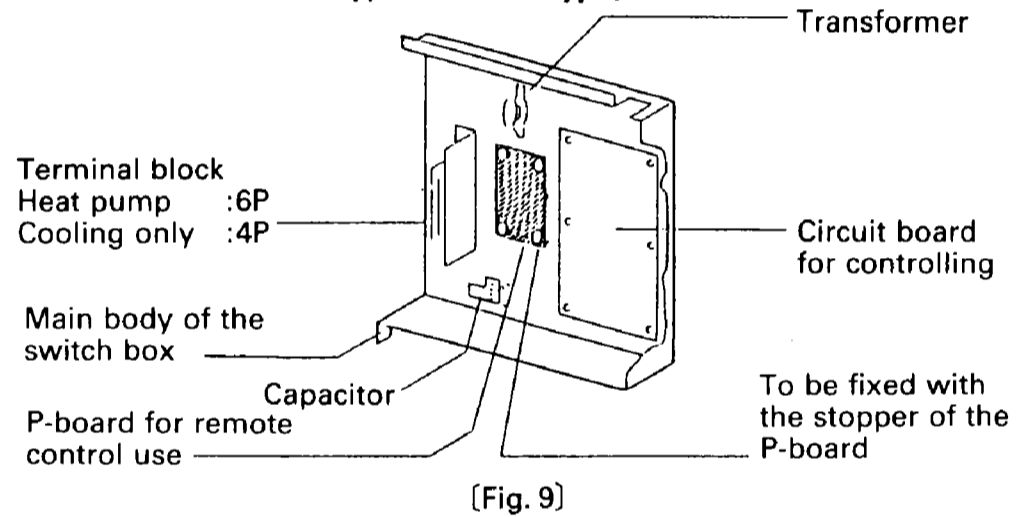
be passed through the C □ part of the electrical equipment box (A).

- After treating the harness and others, they shall be put away as before.
- When installing the cap of the electrical equipment box (A), attention shall be paid not to leave or pinch the harness between the cap and the main body. (Fig.7)

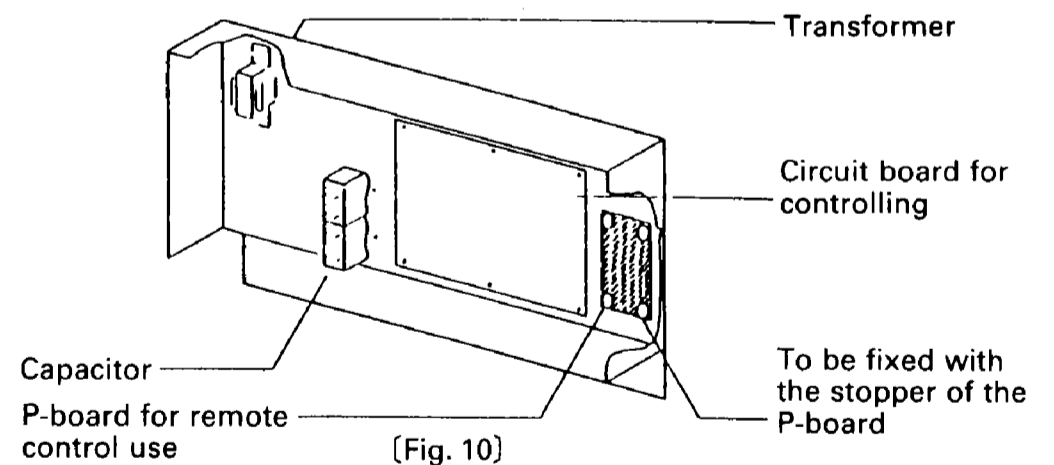
**(5) In case of FH(Y)S-BA type**



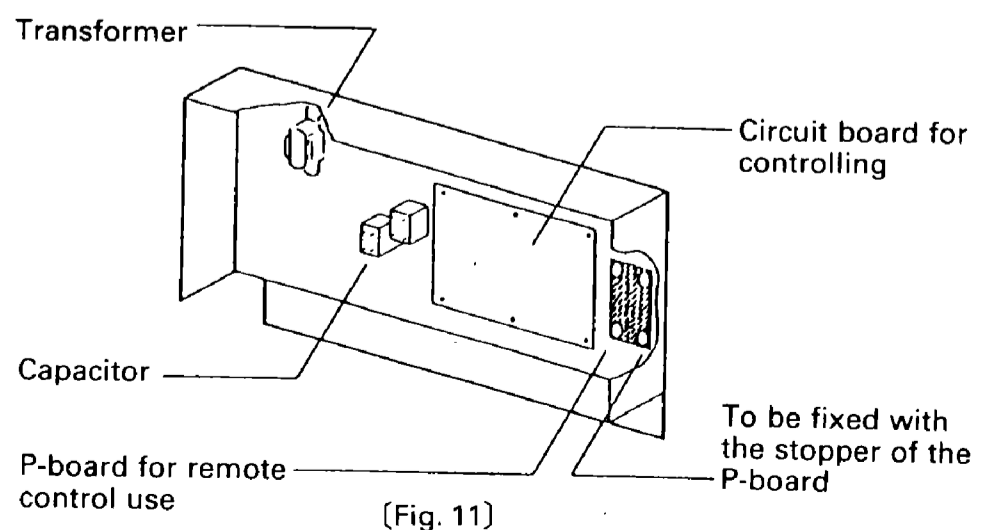
**(6) In case of FA(Y)-B type (71~100 type)**



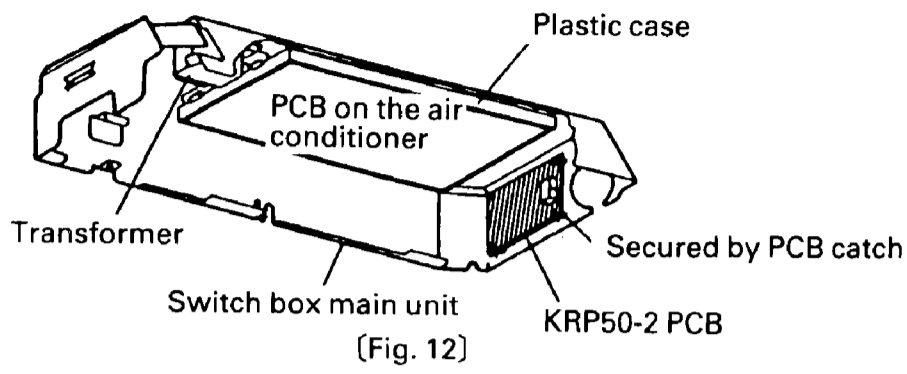
**(7) In case of FV(Y)-B type (71 type)**



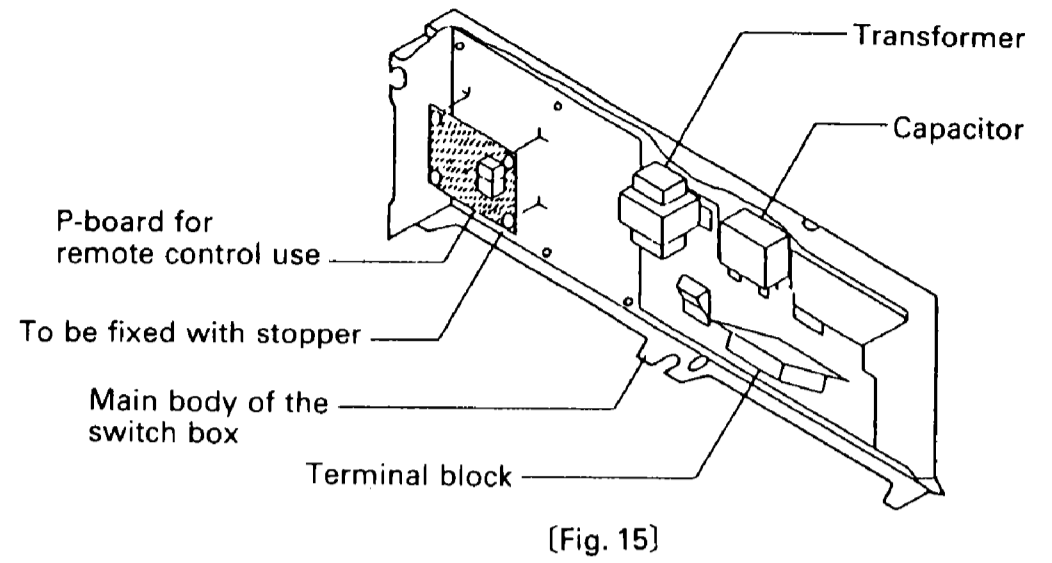
**(100~125 type)**



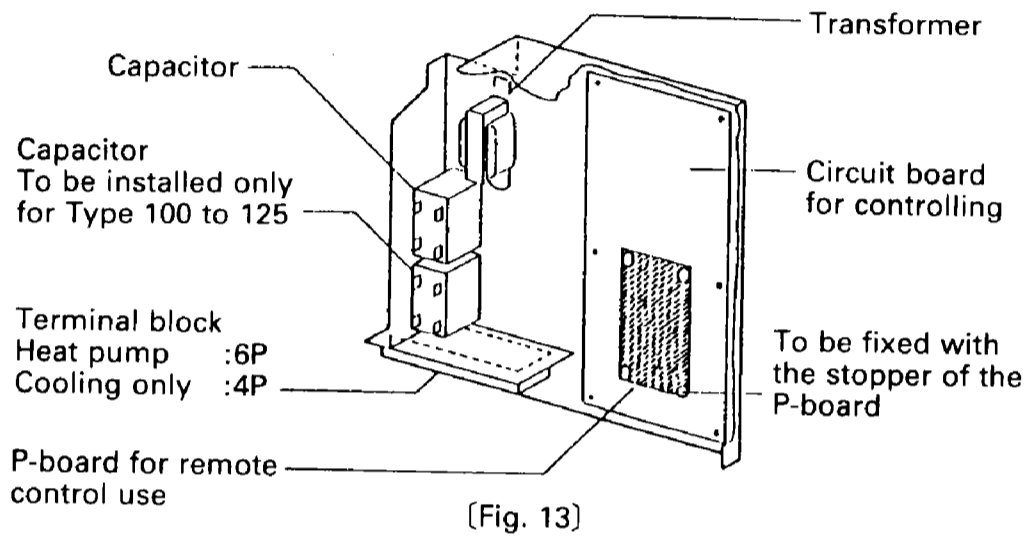
**(8) in case of FHC-C type**



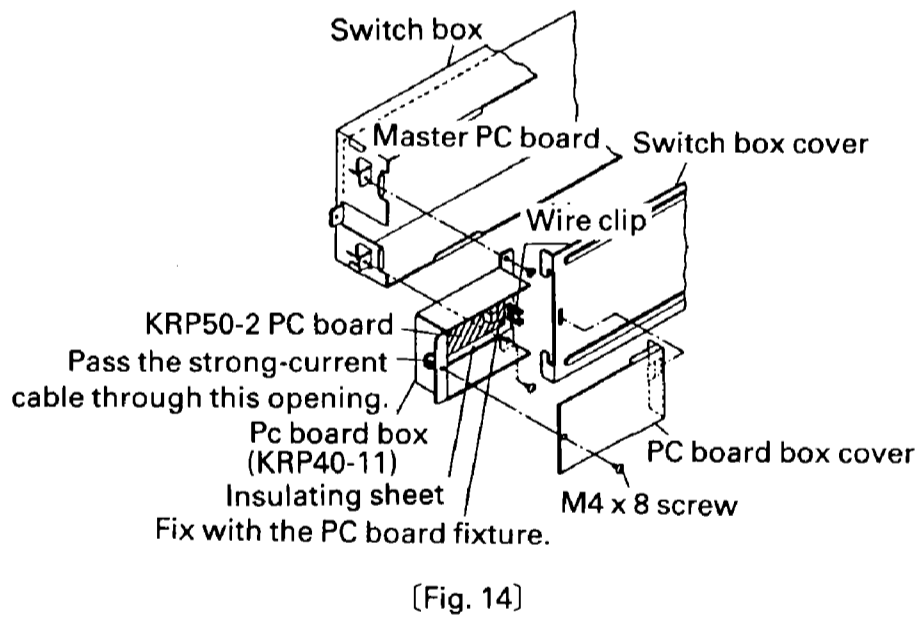
**(11) In case of FH(Y)-BA type**



**(9) In case of FHYC-BA(BB) type**



**(10) In case of FH-C type**



Note: Put insulating sheet in between the KRP50-2 PC board and the PC board box (KRP40-11).  
Fix the leads and connection wires in position with the wire clip.

### 3 Wiring adaptor for Time clock / Remote control (Normal open contact)

#### KRP410A11S <For FT25E(A), F·35E(A)>

##### <Purpose>

- It controls a small number of units remotely.
- It is unable to operate the unit by the remote controller for the indoor unit, so that it prevents the mischief by the children in school, kindergarten or nursery.

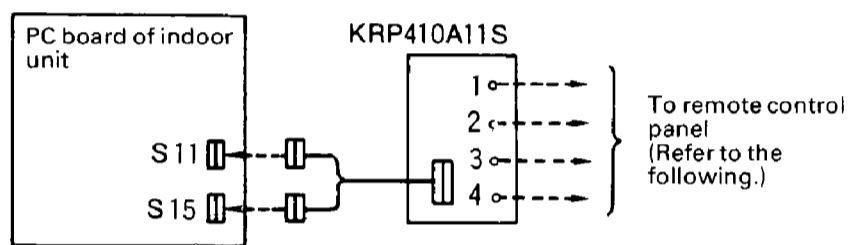
##### <Optional kit required>

- Wiring adaptor for remote control—KRP410A11S
- Connecting wire for remote control
- Other parts supplied locally

##### <Control>

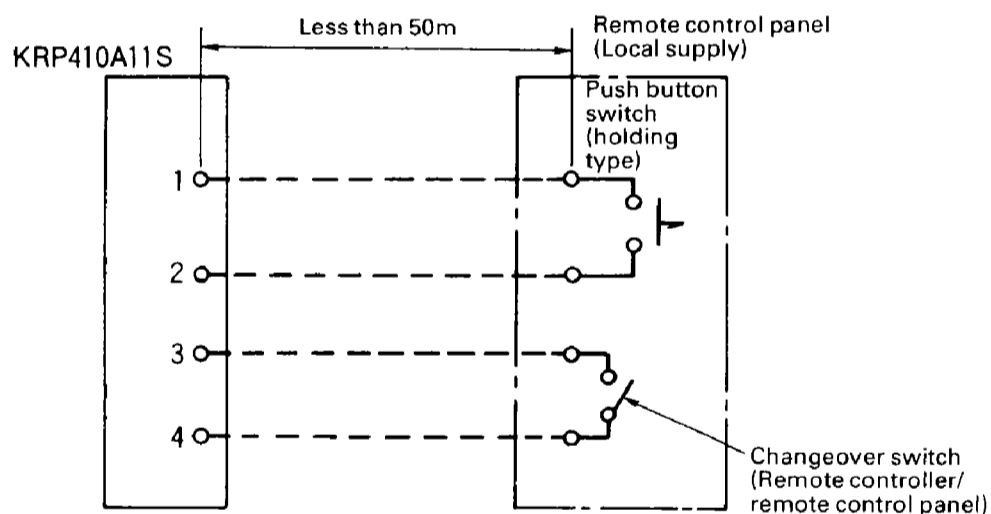
- Operation/Stop by the remote control panel.
- Temperature setting, operation mode, air volume etc. should be set by the remote controller for indoor unit.

##### <Connection with PC board of indoor unit>



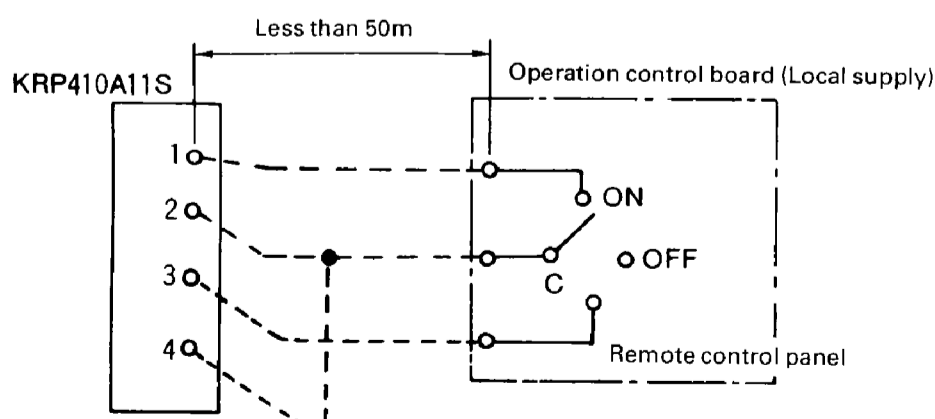
##### <Example of wiring>

- ① Changeover of operation between remote control and remote controller for indoor unit.



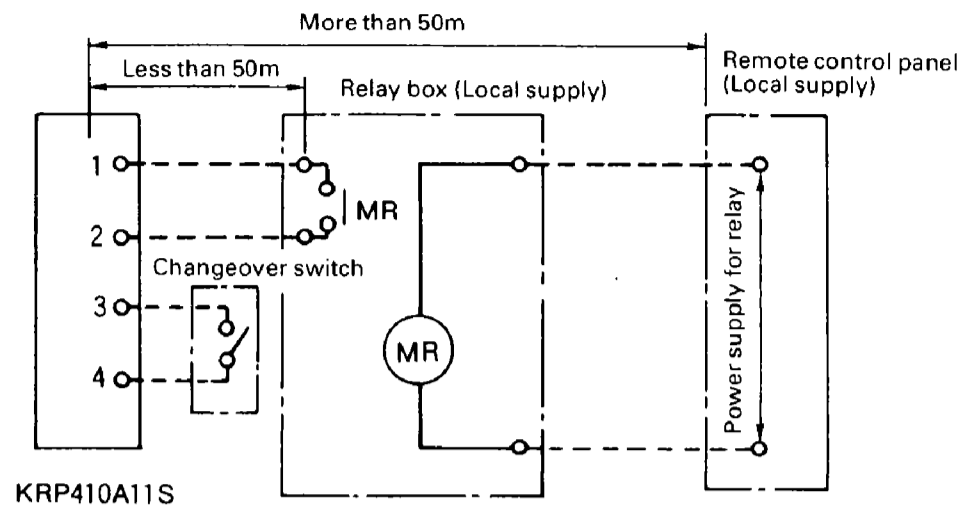
- The operation can be controlled by the remote controller for indoor unit when the changeover switch is "ON", and by the remote control panel when the changeover switch is "OFF". It cannot be operated by both remote controller for indoor unit and remote control panel simultaneously.

- ② Remote control by single switch

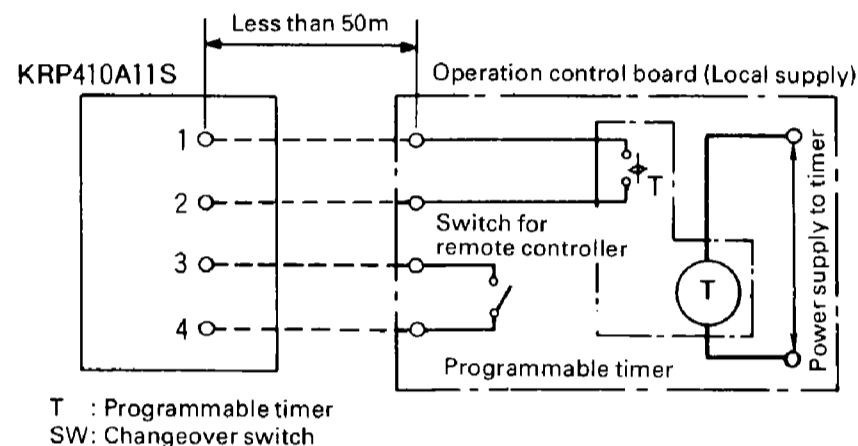


- If you use the selector switch having three contacts, both operation/stop control and changeover between remote controller for indoor unit and remote control panel can be controlled by the single switch.

- ③ When the control wiring exceeds 50m.

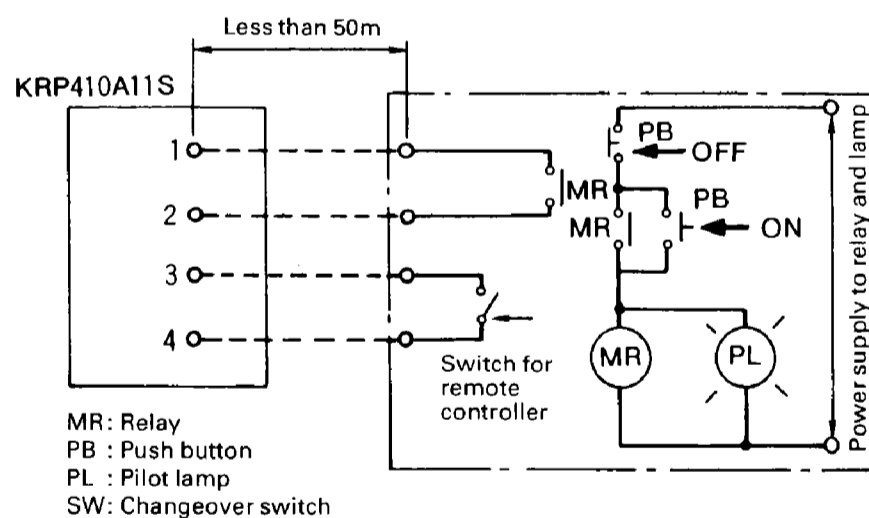


- ④ Operation/stop by programmable timer



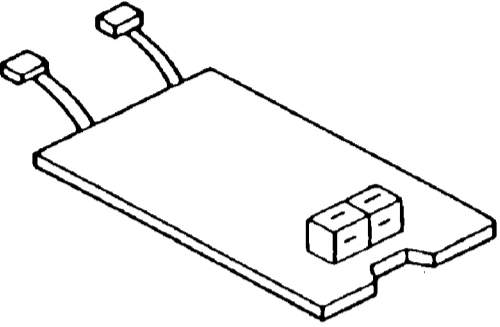
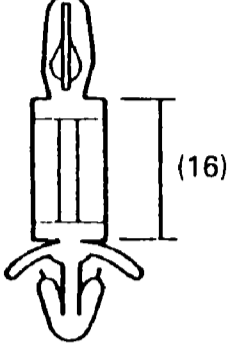
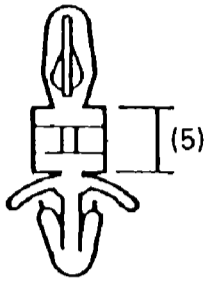
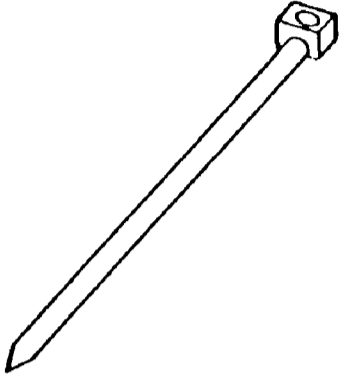
- The operation by remote controller for indoor unit is also possible by installing the changeover switch. (However, if it is set on the remote controller for indoor unit, it can not be operated by the programmable timer.)

- ⑤ To display the operation of the unit



# KRC74 <For FT45E(A) · 60E(A), FV45C · 60C, FT-31B>

## ① Parts of Components

(1) Print board (1 pc.) (KDC100A21)	(2) Stopper for P-Board (4 pcs. of each of large and small)	(3) Tie-wrap (1 pc.)
	<div style="display: flex; justify-content: space-around;"> <div style="text-align: center;"> <p>(Large)</p>  <p>(16)</p> </div> <div style="text-align: center;"> <p>(Small)</p>  <p>(5)</p> </div> </div> <p style="text-align: center;">Large: for sky air use Small: for room air conditioning use</p>	
<p>* Manual: for sky air use ..... 1 copy for room air conditioning use ..... 1 copy</p>		

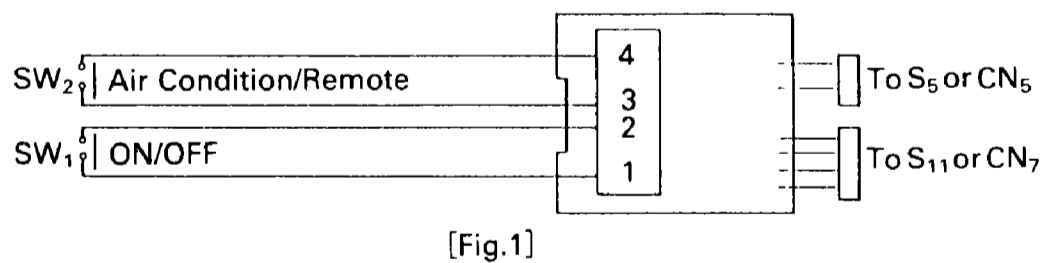
## ② Installation procedures

- 1) The connecting wire shall be connected with the terminal block of the print board (according to the connecting procedures shown in Fig.1).
- 2) The connector of the print board shall be connected with P-board of the main body.  
Nos. of the connector to be connected is:  
Room air conditioner ..... S<sub>11</sub> and S<sub>15</sub>  
Sky air ..... CN<sub>5</sub> and CN<sub>7</sub>
- 3) When the connection work is completed, the print board shall be stored in the specified position of the air conditioner.

## ③ Connecting wiring

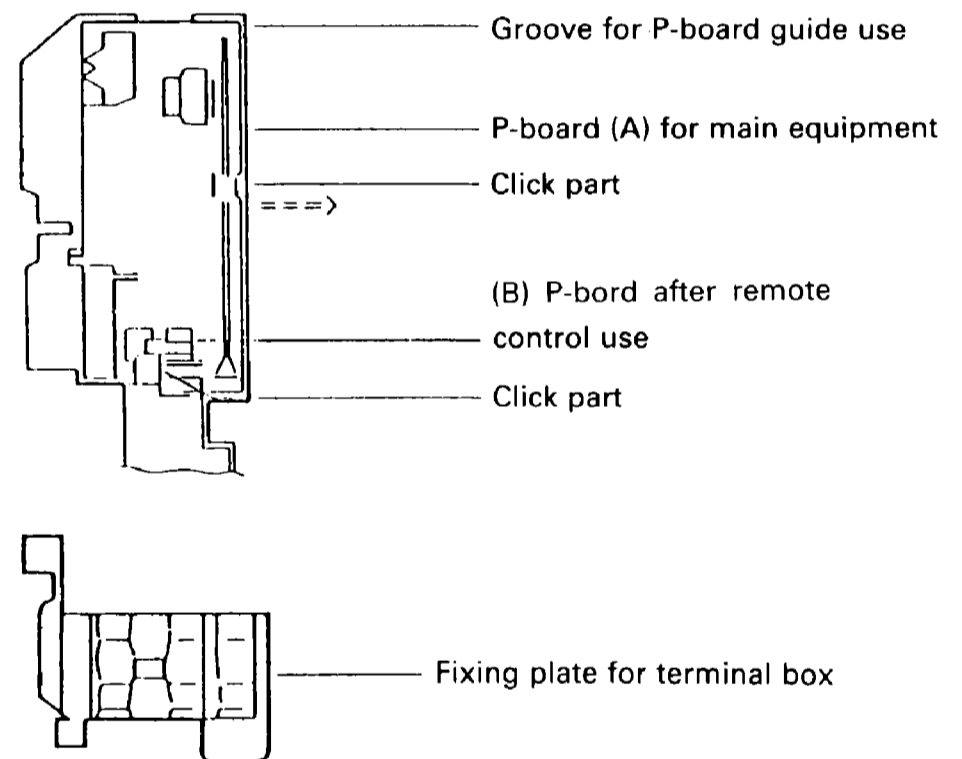
The cables for connection wiring shall be applied according to the following specification.

Four core cables with sheath of 0.15 to 0.3mm<sup>2</sup>



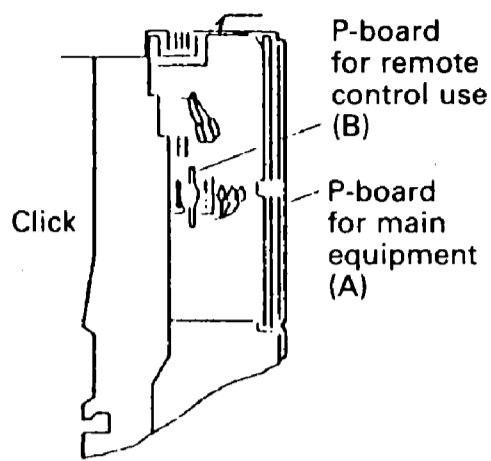
- While SW<sub>2</sub> is opened, the air conditioner can be driven or stopped by handling only SW<sub>1</sub>.
- While SW<sub>2</sub> is closed, the air conditioner can be driven or stopped in only the main body side of the air conditioner.

### (1) Wall mounted type FT25E(A), FTY22/223A



- 1) The fixing plate for the terminal board shall be removed.
- 2) The connection wires shall be connected with the terminal block of P-board (B).
- 3) After drawing out the P-board by drawing the click part in the allow direction, the connector of P-board (B) shall be connected with S<sub>11</sub> and S<sub>15</sub>.
- 4) P-board (A) of the main equipment shall be stored as before. (After inserting the P-board into the groove parts of the left, right and lower sides, the board shall be inserted into the groove of the click part.)
- 5) As shown in the upper drawing, the P-board of (B) shall be inserted by putting the terminal block in the upper and front side. (After inserting the P-board into the groove parts of the left and lower sides, the board shall be inserted into the groove of the click part.)
- 6) The fixing plate of the terminal board shall be installed as it was before.

**(2) Wall mounted type FT35, 45E(A), FTY35/353A**

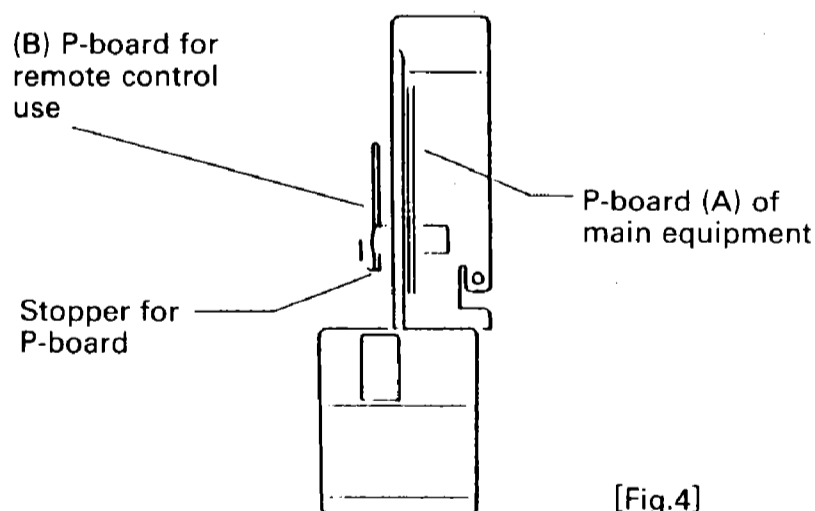


[Fig.3]

- 1) The connection wires shall be connected with the terminal block of P-board (B).
- 2) After drawing out the P-board by drawing the click part in the allow direction, the connector of P-board (B) shall be connected with S<sub>11</sub> and S<sub>15</sub>.
- 3) P-board (A) of the main equipment shall be stored as before. (After inserting the P-board into the groove parts of the left, right and lower sides, the board shall be inserted into the groove of the upper click part.)
- 4) As shown in the upper drawing, the P-board of (B) shall be inserted by putting the terminal block in the upper and front side. (After inserting the P-board into the groove parts of the left and lower sides, the board shall be inserted into the groove of the click part.)

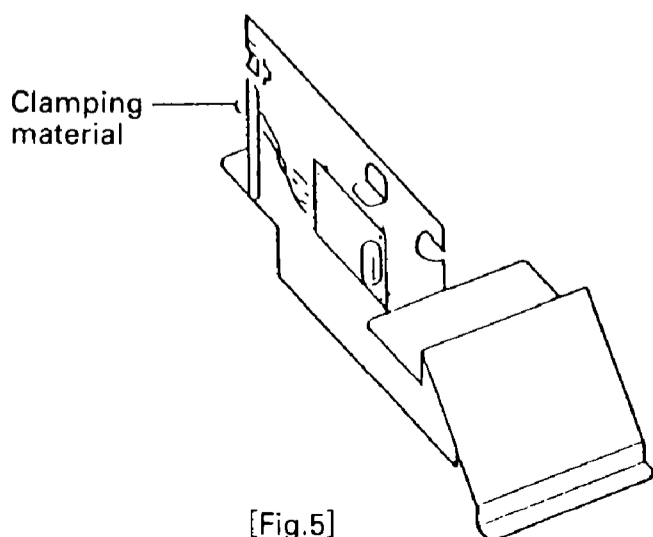
Note: In case of the equipment with heater, the work shall be made easy by disconnecting the plug connection. After the work, it shall be connected as it was before.

**(3) FT60E(A), FTY45/60A and FTY453/603A**



[Fig.4]

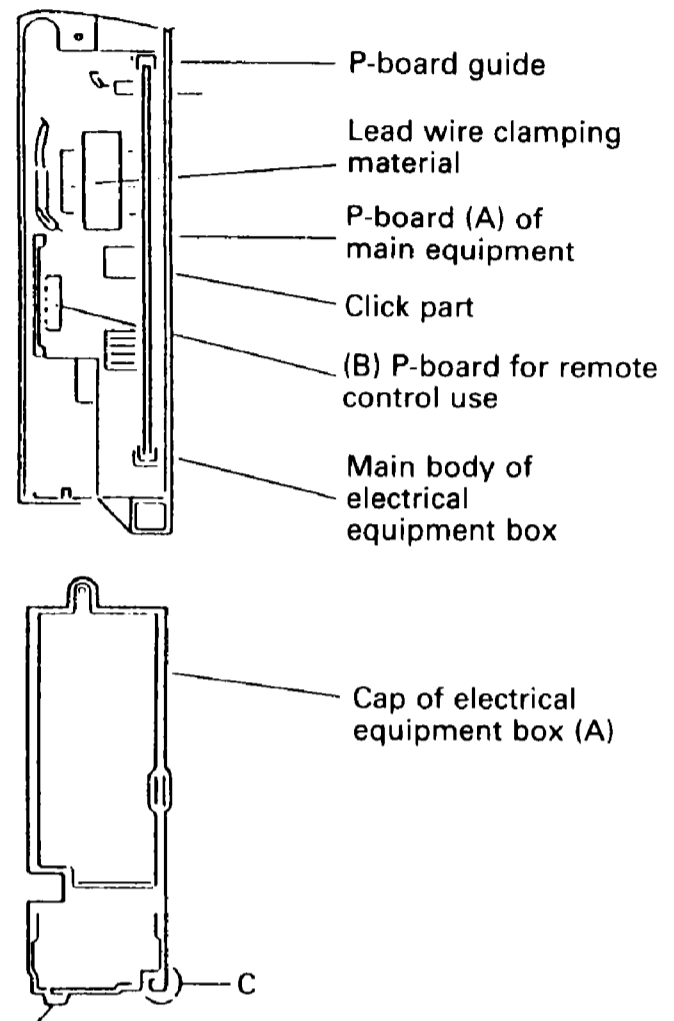
- 1) The connector of P-board (B) shall be connected with S<sub>11</sub> and S<sub>15</sub> of the P-board (A) of the main equipment.
- 2) The connection wires shall be connected with the terminal block of the P-board (B).



[Fig.5]

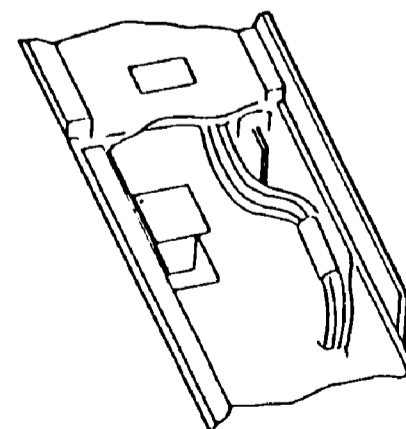
- 3) The P-board (B) shall be installed with the stopper of the P-board on to the electrical equipment box.
- 4) The lead wire from the P-board shall be banded with clamping material at the same position as that of the thermistor lead wire. (Fig.4), (Fig.5)

**(4) Floor-mounted type, FV45~60, FVY22/35/45A**



[Fig.6]

- 1) The cap of the electrical equipment box (A) shall be removed. (After removing one upper part screw, the click part of the main box of the electrical box shall be pushed to inside to slide the box upward.)
- 2) The connection wires shall be connected with the terminal block of the P-board (B).
- 3) After drawing out the P-board (A), the connector of P-board (B) shall be connected with S<sub>11</sub> and S<sub>15</sub>. (When drawing out the P-board (A), S<sub>10</sub> shall be removed, and then, the wire harness shall be removed from the clamping material of the lead wire.)
- 4) P-board (A) of the main equipment shall be stored as before. The P-board (A) shall be inserted into the P-board guide.



[Fig.7]

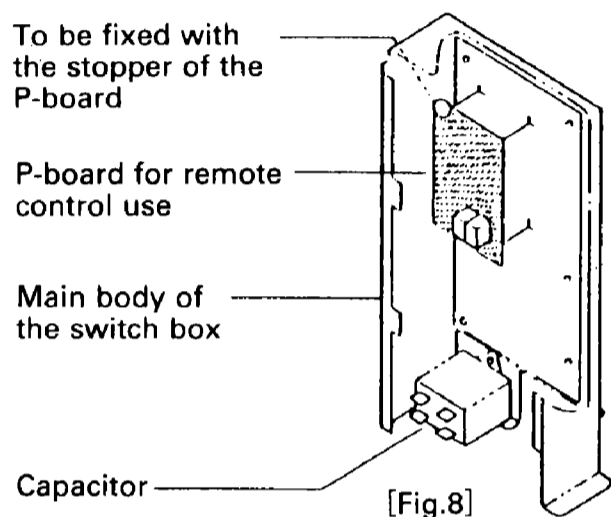
- 5) As shown in Fig.6 the P-board of (B) shall be inserted by putting the terminal block in the front side. (The P-board shall be inserted into the hollow part of the upper and lower grooves.)

6) The cap of electrical equipment box (A) shall be installed as it was before. (After inserting the click part of the cap of the electrical equipment box (A) into the hook part of the box, the screw of the upper part shall be tightened.

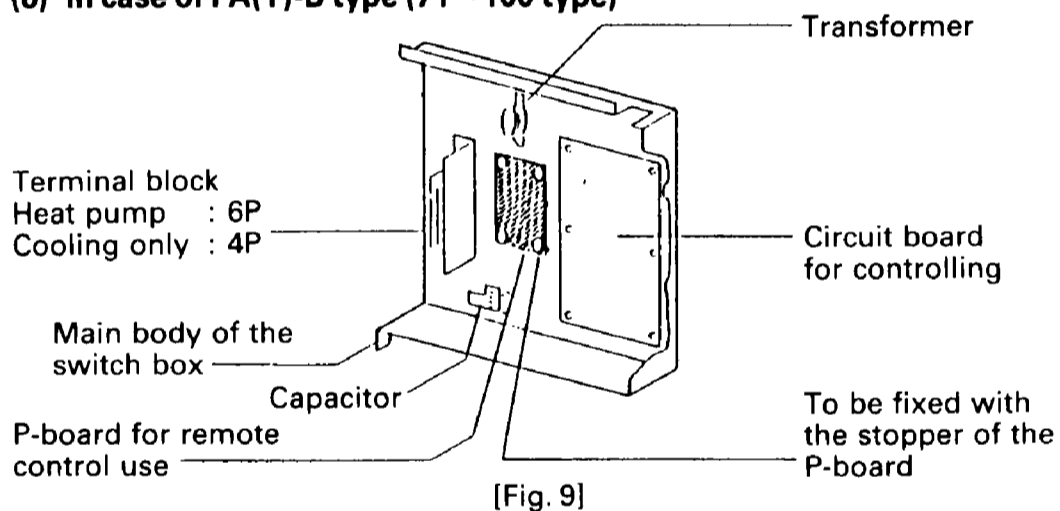
Note: The lead wire of the room temperature thermistor shall be passed through the C □ part of the electrical equipment box (A).

- After treating the harness and others, they shall be put away as before.
- When installing the cap of the electrical equipment box (A), attention shall be paid not to leave or pinch the harness between the cap and the main body. (Fig.7)

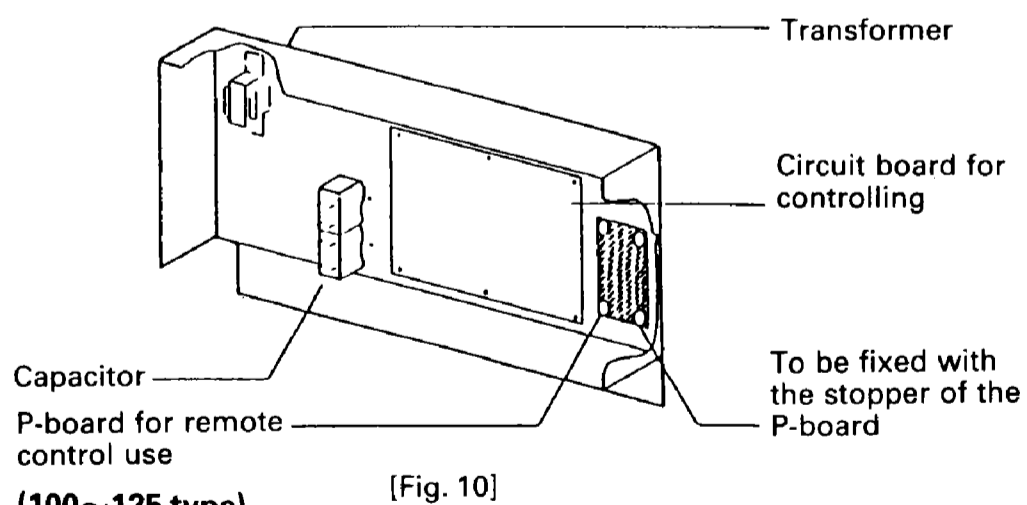
**(5) In case of FH(Y)S-BA type**



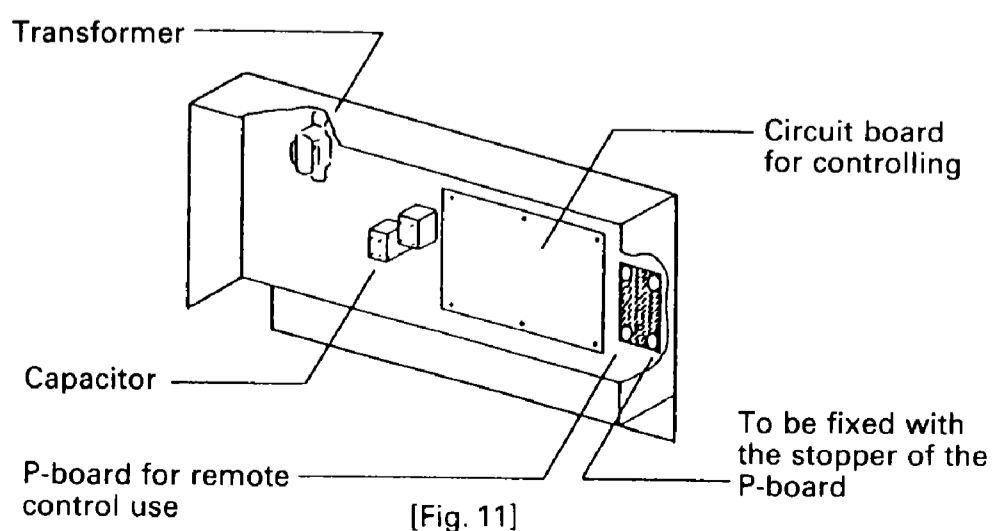
**(6) In case of FA(Y)-B type (71~100 type)**



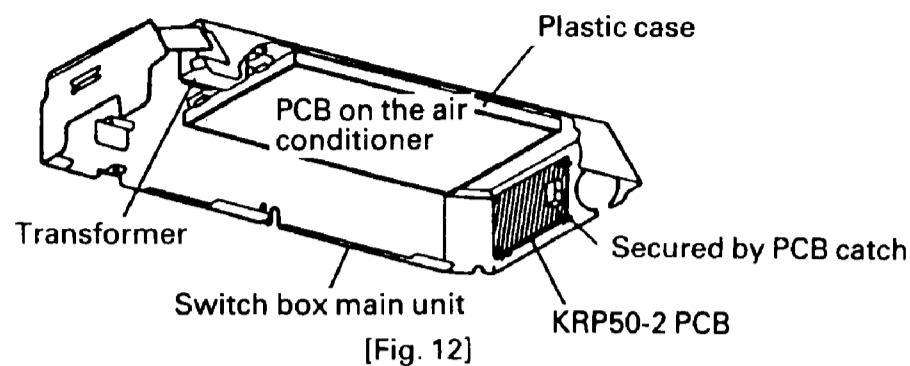
**(7) In case of FV(Y)-B type (71 type)**



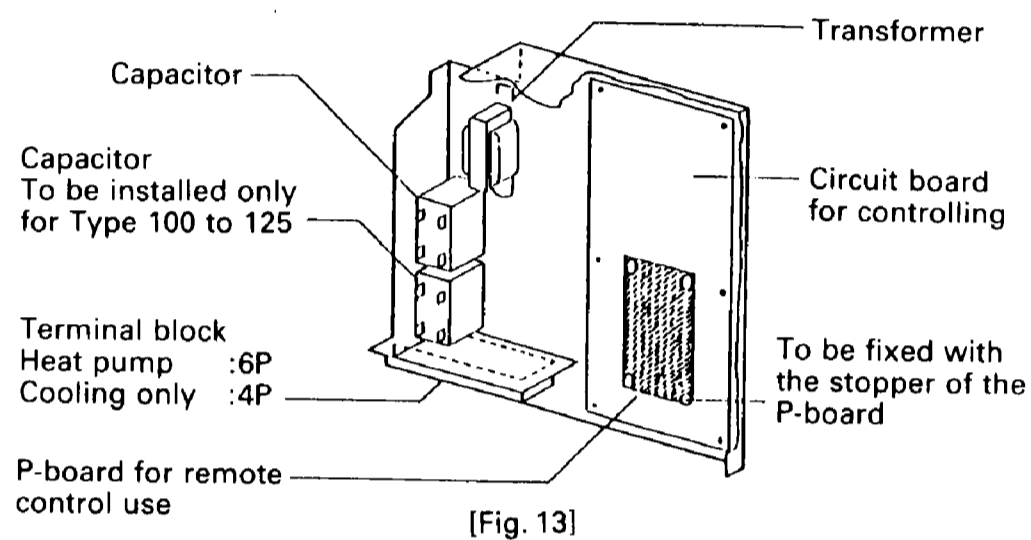
**(100~125 type)**



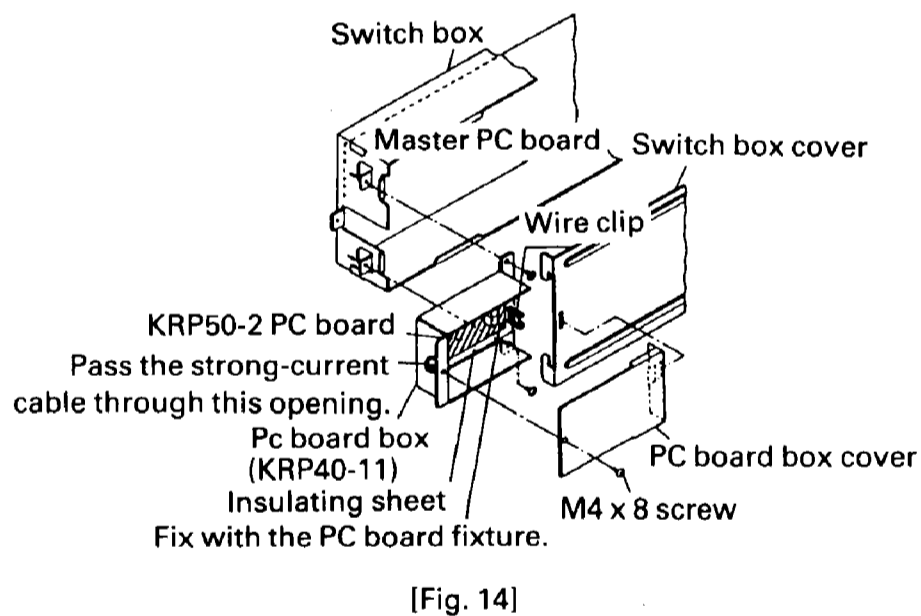
**(8) in case of FHC-C type**



**(9) In case of FHYC-BA(BB) type**

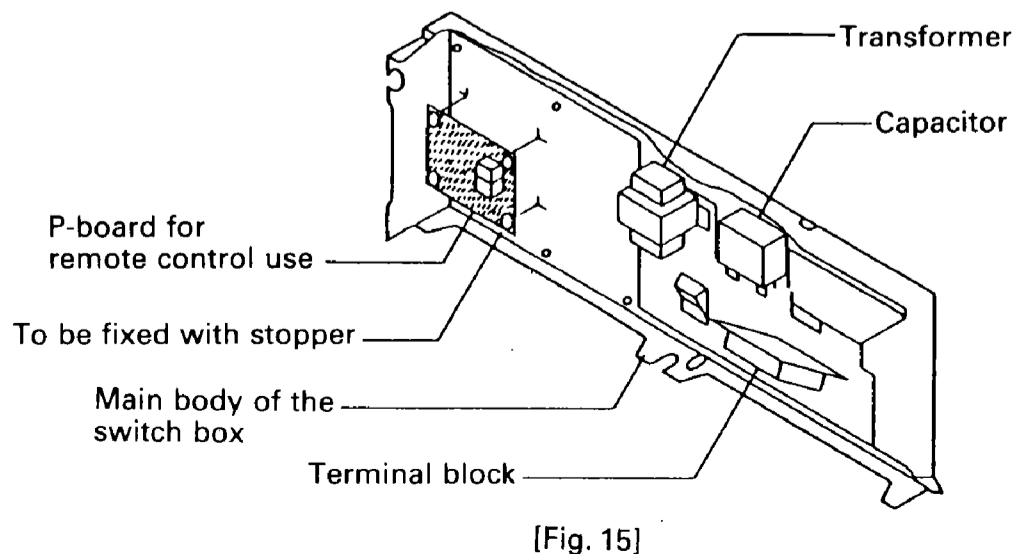


**(10) In case of FH-C type**



Note: Put insulating sheet in between the KRP50-2 PC board and the PC board box (KRP40-11). Fix the leads and connection wires in position with the wire clip.

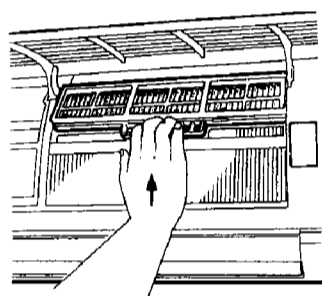
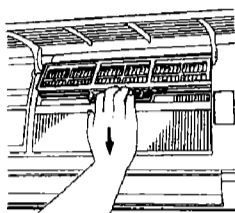
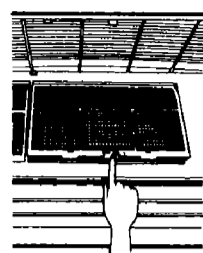
**(11) In case of FHY-B type**





## 4 Air purifying filter with frame

KAF492A1 <For FT25, 35E(A)>



### Instruction for replacement

■ Air Purifying Filter need to be replaced every 3 months, on average, at general houses.

- Check the filters sometimes. If the filter colour is similar to either of the sample colours on the sticker, replace them even if they have not been used for 3 months.

#### [HOW TO REPLACE AIR PURIFYING FILTER ]

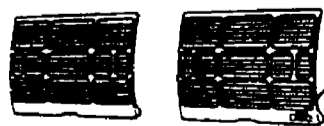
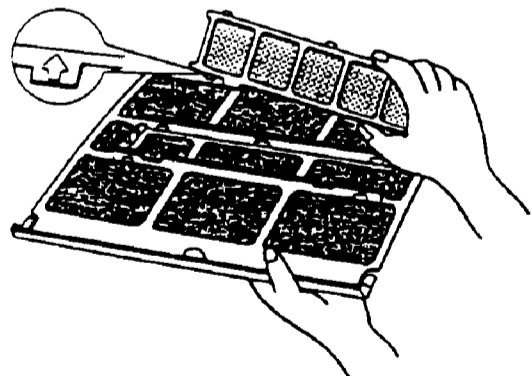
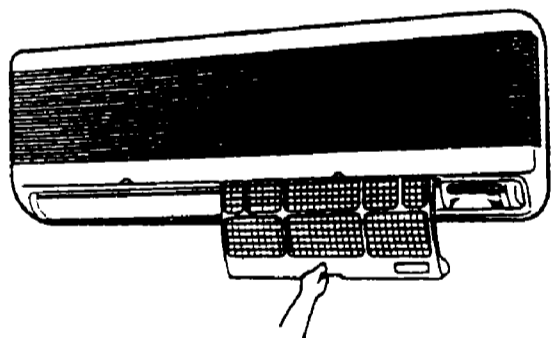
1. ● Pull out the air filters of the unit.
  - Remove the Air Purifying Filters.  
(Refer to the instructions for details.)
2. Replace them with new Air Purifying Filters.
  - \* Write the date of replacement in the sticker and put it at a conspicuous place on the filter frame as a reminder for the next replacement.
3. Set the air filters back in place and close the front panel securely.

#### (NOTE)

1. Do not open a plastic bag until you put them to use. (Opening the plastic bag when they are not in use, will shorten the life of Air Purifying Filter.)
2. Air Purifying Filter can not be used repeatedly by washing.
3. As for order for Air Purifying Filter, please contact the shop you purchased this product.

Code:KAF492A1

KAF96A41 <For FT25F>



### Instruction for replacement

■ Air Purifying Filter need to be replaced every 3 months, on average, at general houses.

- Check the filters sometimes. If the filter colour is similar to either of the sample colours on the sticker, replace them even if they have not been used for 3 months.

#### [HOW TO REPLACE AIR PURIFYING FILTER ]

1. ● Pull out the air filters of the unit.
2. Replace them with new Air Purifying Filters.
  - (Refer to the operation manual for details.)
  - \* Write the date of replacement in the sticker and put it at a conspicuous place on the filter frame as a reminder for the next replacement.
3. Set the air filters back in place.

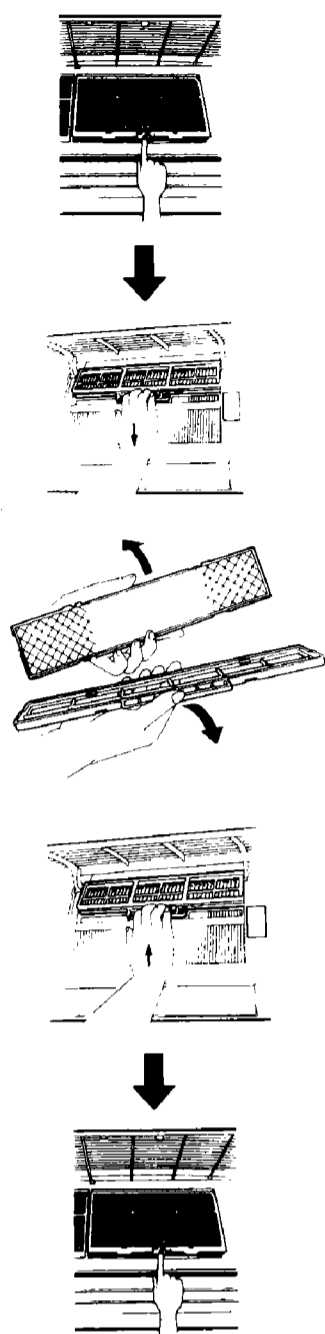
#### (NOTE)

1. Do not open a plastic bag until you put them to use. (Opening the plastic bag when they are not in use, will shorten the life of Air Purifying Filter.)
2. Air Purifying Filter can not be used repeatedly by washing.
3. As for order for Air Purifying Filter, please contact the shop you purchased this product.

Code:KAF96A41

## 5 Air purifying filter without frame

KAF492A2 <For FT25, 35E(A)>



### Instruction for replacement

■ Air Purifying Filter need to be replaced every 3 months, on average, at general houses.

- Check the filters sometimes. If the filter colour is similar to either of the sample colours on the sticker, replace them even if they have not been used for 3 months.

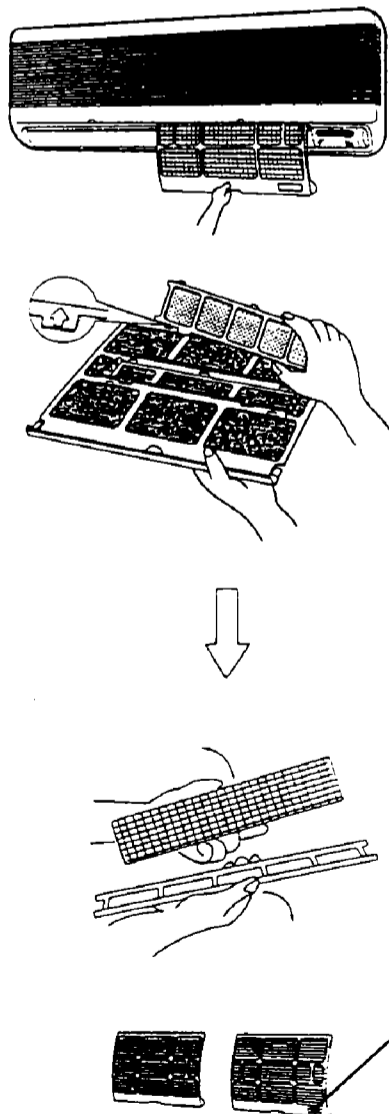
#### [HOW TO REPLACE AIR PURIFYING FILTER ]

1. ● Pull out the air filters of the unit.  
● Remove the Air Purifying Filters.  
(Refer to the instructions for details.)
2. Replace them with new Air Purifying Filters.  
\* Hold the arrowed parts and pull the filter apart from the frame.  
\* Replace them with new Air Purifying Filters and set them back as they were.  
\* Write the date of replacement in the sticker and put it at a conspicuous place on the filter frame as a reminder for the next replacement.
3. ● Set the new air purifying filter on the unit.  
● Set the air filter back in place.

#### (NOTE)

1. Do not open a plastic bag until you put them to use. (Opening the plastic bag when they are not in use, will shorten the life of Air Purifying Filter.)
2. Air Purifying Filter can not be used repeatedly by washing.
3. As for order for Air Purifying Filter, please contact the shop you purchased this product. **Code:KAF492A2**

KAF96A42 <For FT25F>



### Instruction for replacement

■ Air Purifying Filter need to be replaced every 3 months, on average, at general houses.

- Check the filters sometimes. If the filter colour is similar to either of the sample colours on the sticker, replace them even if they have not been used for 3 months.

#### [HOW TO REPLACE AIR PURIFYING FILTER ]

1. ● Pull out the air filters of the unit.
2. Replace them with new Air Purifying Filters.  
(Refer to the operation manual for details.)  
\* Replace them with new Air Purifying Filters and set them back as they were.  
\* Write the date of replacement in the sticker and put it at a conspicuous place on the filter frame as a reminder for the next replacement.
3. ● Set the air filter back in place.

#### (NOTE)

1. Do not open a plastic bag until you put them to use. (Opening the plastic bag when they are not in use, will shorten the life of Air Purifying Filter.)
2. Air Purifying Filter can not be used repeatedly by washing.
3. As for order for Air Purifying Filter, please contact the shop you purchased this product. **Code:KAF96A42**

## 6 Anti-theft protection for wireless remote controller

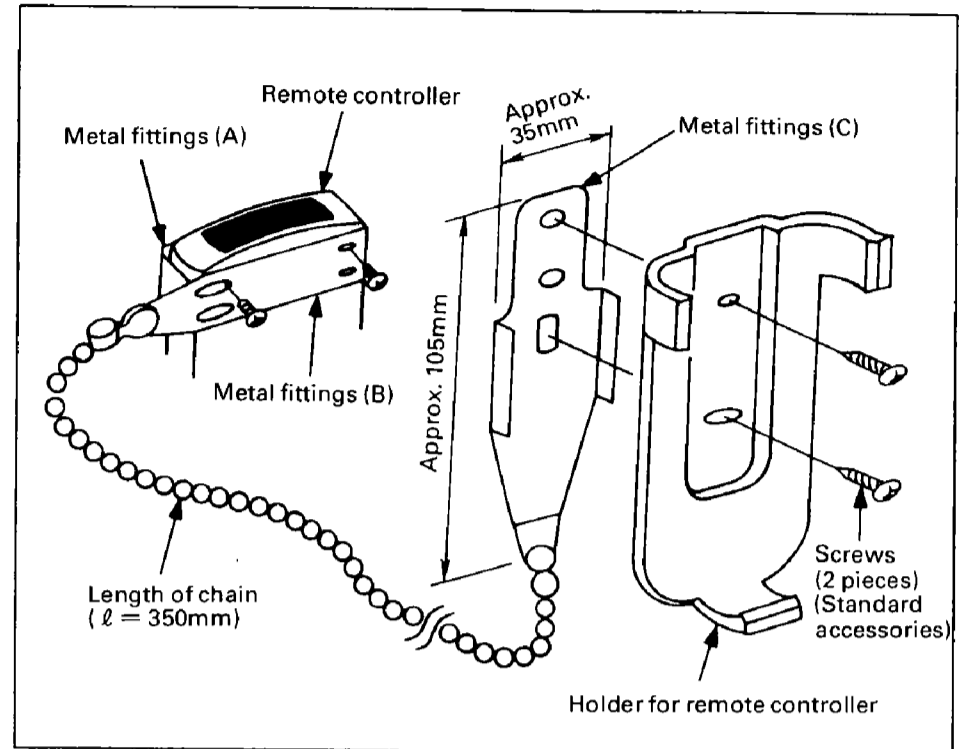
### KKF713A

#### ■ Features

This optional kit is to fix the standard simple remote controller, so that the remote controller shall not be misplaced or stolen.

This optional kit is ideal for the use in the apartment, hotel and etc.

#### ■ Installation



Note : Before you install the holder for remote controller, be sure to select a location where the unit can receive the signal from the remote controller.

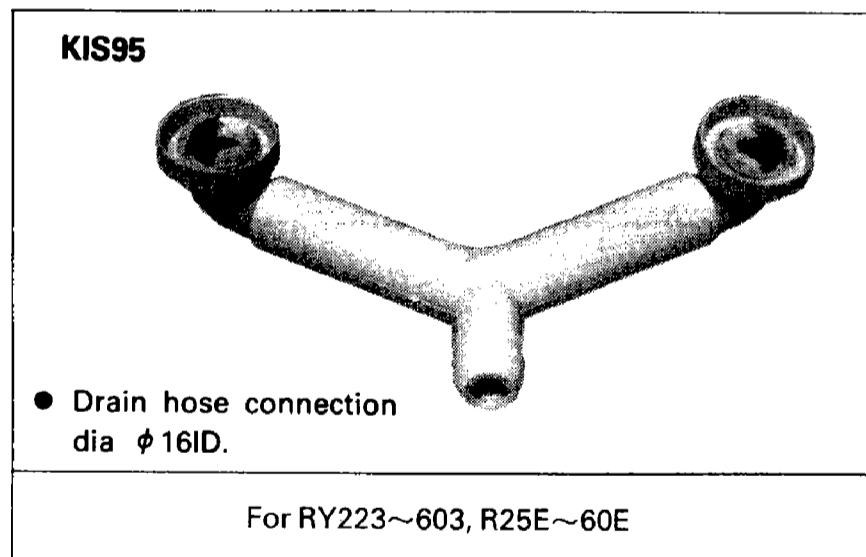
## Outdoor Unit

### 1 Drain piping kit

#### KIS95

Use this plug to connect a drain hose to an outdoor unit.

#### ● Outlook



#### Notes;

1. This is the joint for attaching a vinyl hose (field supplied). This is used between the drain hole which is on the bottom plate of outdoor unit and vinyl hose.
2. Drain water accumulate to the bottom of outdoor unit it depends on the situation of operation. But it is necessary to connect drain hose not to be spread the drain water over the neighbors, when it is installed on the wall.

#### KIS95

Drain plug  
(With Y joint)  
plug (3 pcs.)

## 2. SKY AIR-F Series

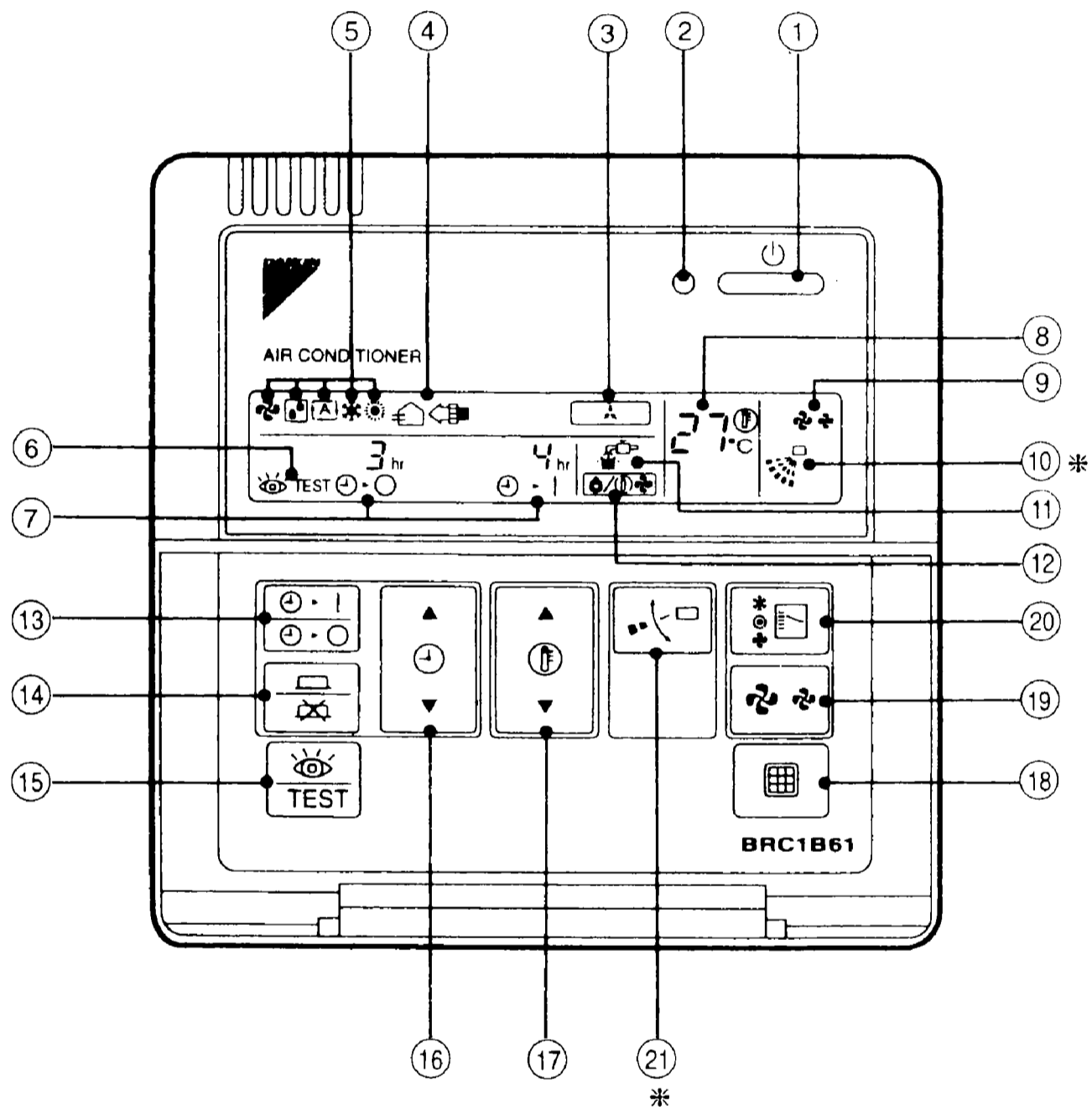
### Indoor Unit

#### 1 Remote controller

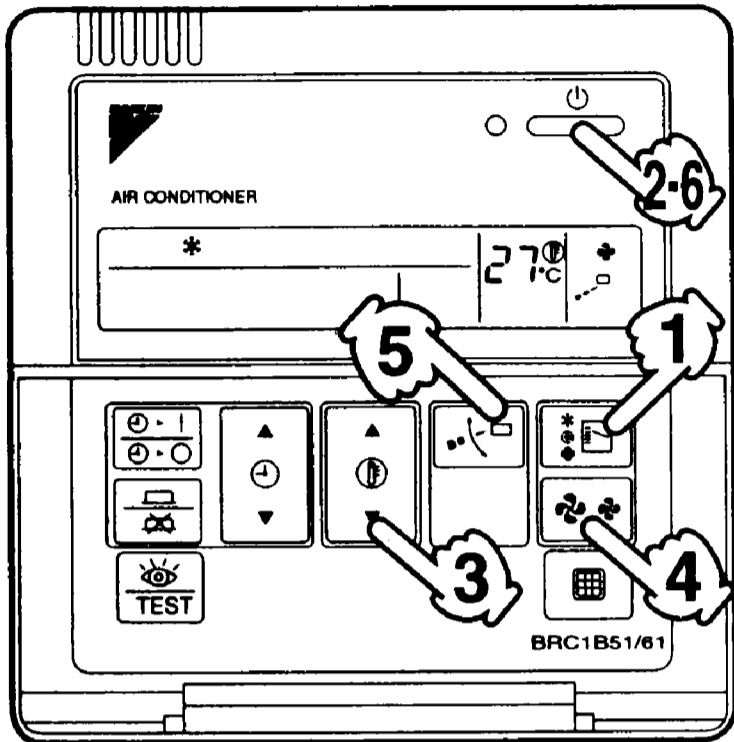
##### 1.1 Wired type — BRC1B61 <For FH(Y)C-F, FH(Y)K-F, FHY-F, FA(Y)-F>

##### ★ Operation

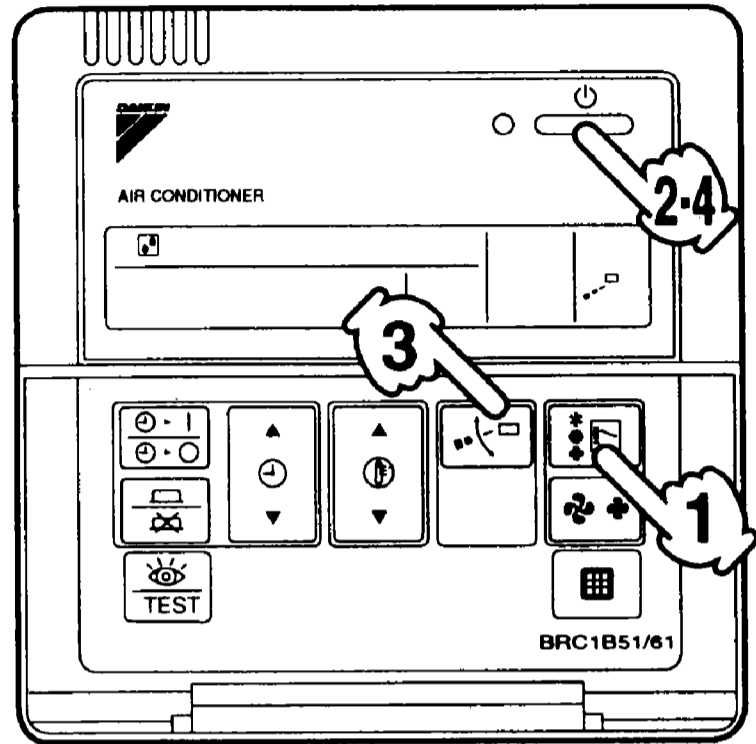
**Fig. 1**



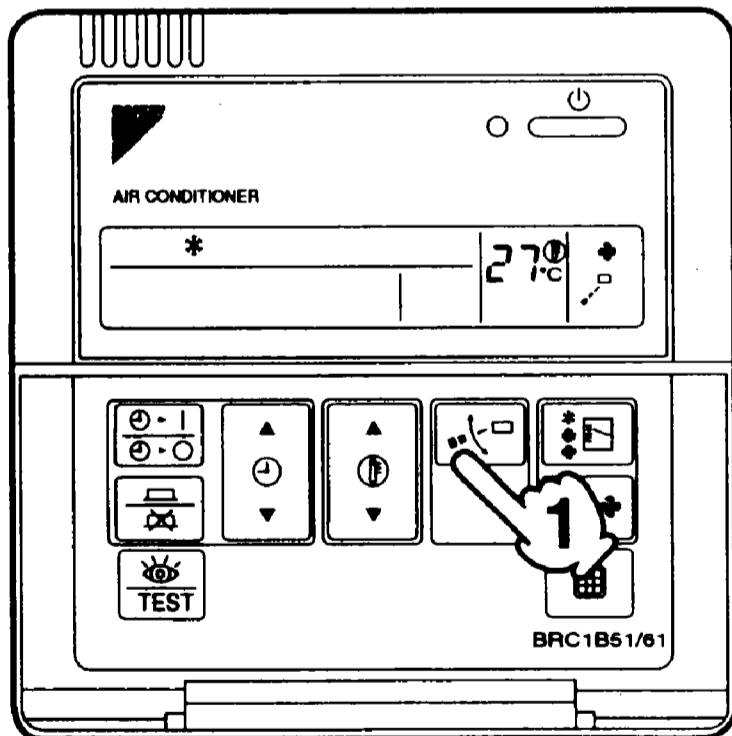
**Fig. 2**



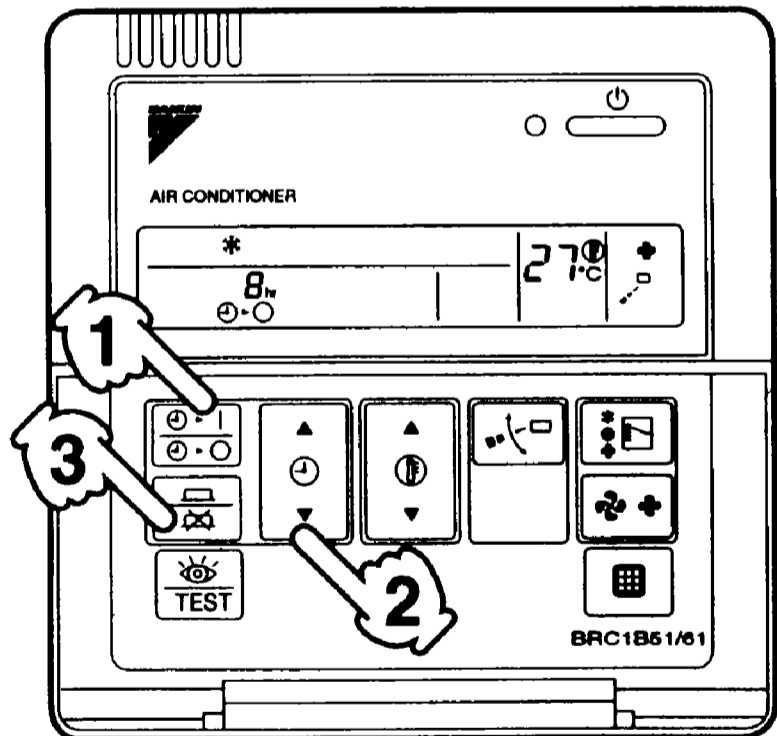
**Fig. 3**




















**Fig. 4**



**Fig. 5**



# NAME AND FUNCTION OF EACH SWITCH AND DISPLAY ON THE REMOTE CONTROLLER (Fig. 1)


①	<b>ON/OFF BUTTON</b> Press the button and the system will start. Press the button again and the system will stop.	⑫	<b>DISPLAY “” (DEFROST)</b> Refer to page 18.
②	<b>OPERATION LAMP (RED)</b> The lamp lights up during operation.	⑬	<b>TIMER MODE START/STOP BUTTON</b> Refer to page 19.
③	<b>DISPLAY “” (UNDER CENTRALIZED CONTROL)</b> When this display shows, the system is UNDER CENTRALIZED CONTROL. (This is not a standard specification.)	⑭	<b>TIMER ON/OFF BUTTON</b> Refer to page 19.
④	<b>DISPLAY “ ” (VENTILATION/AIR CLEANING)</b> This display shows that the total heat exchange and the air cleaning unit are in operation. (These are optional accessories).	⑮	<b>INSPECTION/TEST OPERATION BUTTON</b> This button is used only by qualified service persons for maintenance purposes.
⑤	<b>DISPLAY “” “” “<b>[A]</b>” “” “” (OPERATION MODE)</b> This display shows the current OPERATION MODE. For straight cooling type, “ <b>[A]</b> ” (Auto) and “  ” (Heating) are not installed.	⑯	<b>PROGRAMMING TIME BUTTON</b> Use this button for programming “START and/or STOP” time.
⑥	<b>DISPLAY “ TEST” (INSPECTION/TEST OPERATION)</b> When the INSPECTION/TEST OPERATION BUTTON is pressed, the display shows the system mode is in.	⑰	<b>TEMPERATURE SETTING BUTTON</b> Use this button for SETTING TEMPERATURE.
⑦	<b>DISPLAY “ hr  hr” (PROGRAMMED TIME)</b> This display shows PROGRAMMED TIME of the system start or stop.	⑱	<b>FILTER SIGN RESET BUTTON</b>
⑧	<b>DISPLAY “ °C” (SET TEMPERATURE)</b> This display shows the set temperature.	⑲	<b>FAN SPEED CONTROL BUTTON</b> Press this button to select the fan speed, HIGH or LOW, of your choice.
⑨	<b>DISPLAY “ ” (FAN SPEED)</b> This display shows the set fan speed.	⑳	<b>OPERATION MODE SELECTOR BUTTON</b> Press this button to select OPERATION MODE.
* ⑩	<b>DISPLAY “” (AIR FLOW FLAP)</b> Refer to page 19.	* ㉑	<b>AIR FLOW DIRECTION ADJUST BUTTON</b> Refer to page 19.
⑪	<b>DISPLAY “” (TIME TO CLEAN AIR FILTER)</b>	(NOTE) <ul style="list-style-type: none"> <li>● For the sake of explanation, all indications are shown on the display in Figure 1 contrary to actual running situations.</li> <li>● Items and the buttons marked with * are only attached for the heat pump type. They are not attached to straight cooling type.</li> </ul>	


# OPERATION PROCEDURE


- Operating procedure varies with heat pump type and straight cooling type. Contact your Daikin dealer to confirm your system type.
- To protect the unit, turn on the main power switch 6 hours before operation.
- If the main power supply is turned off during operation, operation will restart automatically after the power turns back on again.


## COOLING, HEATING, AUTOMATIC, AND FAN OPERATION (Fig. 2)

- 1** Press **OPERATION MODE SELECTOR** button several times and select the **OPERATION MODE** of your choice as follows.

COOLING OPERATION ..... "  "

HEATING OPERATION ..... "  "

AUTOMATIC OPERATION ..... "  "

FAN OPERATION ..... "  "

- For straight cooling type, "cooling" and "fan" operation are able to select.

### AUTOMATIC OPERATION

In this operation mode, COOL/HEAT changeover is automatically conducted.

- 2** Press **ON/OFF** button

OPERATION lamp lights up and the system starts OPERATION.

### Adjustment

For programming TEMPERATURE, FAN SPEED and AIR FLOW DIRECTION, follow the procedure shown below.

- 3** Press **TEMPERATURE SETTING** button and program the setting temperature.

▲	Each time this button is pressed, setting temperature rises 1°C.
⊕	
▼	Each time this button is pressed, setting temperature lowers 1°C.

- The setting is impossible for fan operation.

NOTE: The setting temperature range of the remote controller is 16 to 32°C.

- 4** Press **FAN SPEED CONTROL** button.

High or Low fan speed can be selected.

- 5** Press **AIR FLOW DIRECTION** button

(For heat pump type)

Refer to "ADJUSTING THE AIR FLOW DIRECTION" (p. 19) for details.


### STOPPING THE SYSTEM

- 6** Press **ON/OFF** button once again.

OPERATION lamp goes off, and the system stops OPERATION.

## EXPLANATION OF HEATING OPERATION

### DEFROST OPERATION

- As the frost on the coil of an outdoor unit increase, heating effect decreases and the system goes into DEFROST OPERATION.
- The indoor unit fan stops and the remote controller display shows "  "
- After 6 to 8 minutes (maximum 10 minutes) of DEFROST OPERATION, the system returns to HEATING OPERATION.

## PROGRAM DRY OPERATION (Fig. 3)

- The function of this program is to decrease the humidity in your room with the minimum temperature decrease.
- Micro computer automatically determines TEMPERATURE and FAN SPEED.
- This system does not go into operation if the room temperature is below 16°C.

- 1** Press **OPERATION MODE SELECTOR** button several times and select "  " (PROGRAM DRY OPERATION)

- 2** Press **ON/OFF** button

OPERATION lamp lights up and the system starts OPERATION.

## Adjustment

### 3 Press AIR FLOW DIRECTION ADJUST button. (For heat pump type)

Refer to "ADJUSTING THE AIR FLOW DIRECTION" for details.

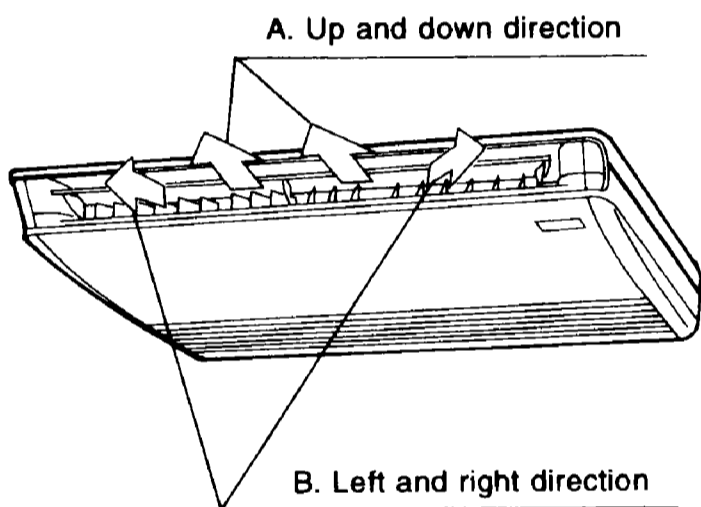
## STOPPING THE SYSTEM

### 4 Press ON/OFF button again.

OPERATION lamp goes off and the system stops OPERATION.

## ADJUSTING THE AIR FLOW DIRECTION

There are 2 ways of adjusting the air discharge angle.

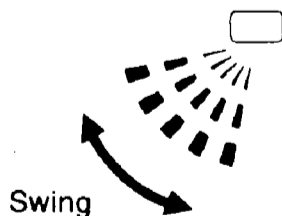


### A. UP AND DOWN DIRECTION

#### ■ For heat pump type (Fig. 4)

### 1 Press the AIR FLOW DIRECTION ADJUST button to select the air direction as shown below.

The AIR FLOW FLAP display swings as shown below and the air flow direction continuously varies. (Automatic swing setting)



Press AIR FLOW DIRECTION ADJUST button to select the air direction of your choice.

The AIR FLOW FLAP display stops swinging and the air flow direction is fixed. (Fixed air flow direction setting)



## MOVEMENT OF THE AIR FLOW FLAP

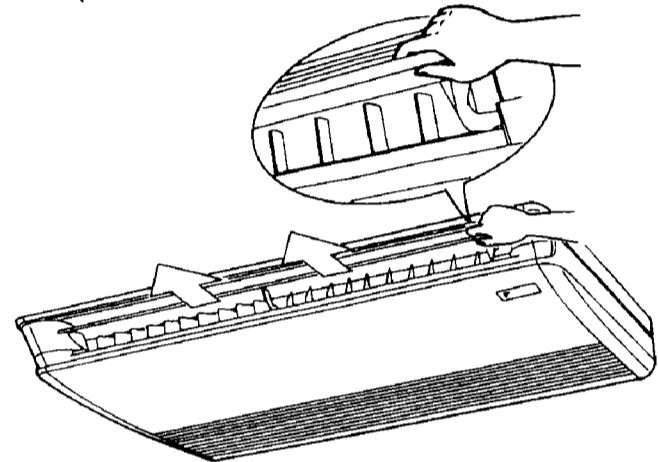
For the following conditions, micro computer controls the air flow direction so it may be different from the display.

Operation mode	Cooling	Heating
Operation conditions	<ul style="list-style-type: none"> <li>When room temperature is lower than the set temperature</li> </ul>	<ul style="list-style-type: none"> <li>When room temperature is higher than the set temperature</li> <li>At defrost operation</li> </ul>
	<ul style="list-style-type: none"> <li>When operating continuously at horizontal air flow direction</li> </ul>	

Operation mode includes automatic operation.

### ■ For straight cooling type

Adjust air flow direction from the right end of the flap as shown in the picture.

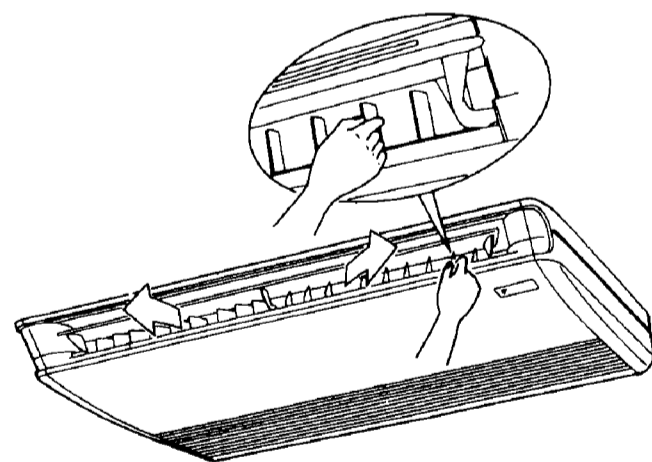


### PRECAUTION

Do not force the flaps so as to prevent breaking and eventual malfunctioning.

### B. LEFT AND RIGHT DIRECTION

Adjusting air flow direction in the left and right direction



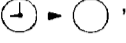
## PROGRAM TIMER OPERATION (Fig. 5)

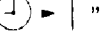
- The timer is operated in the following two ways.
  - Programming the stop time (⏸) ... The system stops operating after the set time has elapsed.
  - Programming the start time (⏹) ... The system starts operating after the set time has elapsed.
- The timer can be programmed a maximum of 72 hours.
- The start and the stop time can be simultaneously programmed.






**1** Press the **TIMER MODE START/STOP** button several times and select the mode on the display.

The display flashes.

For setting the timer stop .... "  "


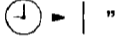
For setting the timer start ... "  "

**2** Press the **PROGRAMMING TIME** button and set the time for stopping or starting the system.

  	<p>When this button is pressed, the time advances by 1 hour.</p> <p>When this button is pressed, the time goes backward by 1 hour.</p>
--	--

**3** Press the **TIMER ON/OFF** button.

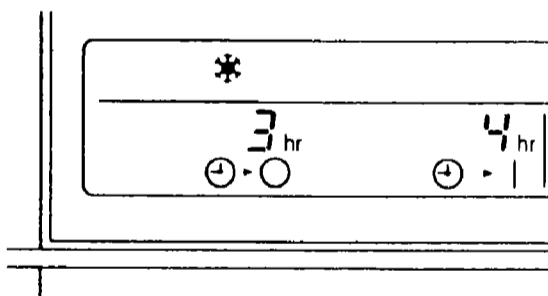
The timer setting procedure ends.

The display "  or  " changes from flashing light to a constant light.

**NOTE:**

- When setting the timer Off and On at the same time, repeat the above procedure from **1** to **3** once again.

For example.



When the timer is programmed to stop the system after 3 hours and start the system after 4 hours, the system will stop after 3 hours and then 1 hour later the system will start.

- After the timer is programmed, the display shows the remaining time.
- Press the **TIMER ON/OFF** button once again to cancel programming. The display vanishes.

## PRECAUTIONS FOR GROUP CONTROL SYSTEM OR TWO REMOTE CONTROLLER CONTROL SYSTEM

This system provides two other control systems beside individual control (one remote controller controls one indoor unit) system. Confirm the following if your unit is of the following control system type.

■ **Group control system**

One remote controller controls up to 16 indoor units.

All indoor units are equally set.

■ **Two remote controller control system**

Two remote controllers control one indoor unit (In case of group control system, one group of indoor units)

The unit is individually operated.

**NOTE:**

Contact your Daikin dealer in case of changing the combination or setting of group control and two remote controller control systems.

# TROUBLE SHOOTING

## I. If one of the following malfunctions occurs, take the measures shown below and contact your Daikin dealer.


The system must be repaired by a qualified service person.

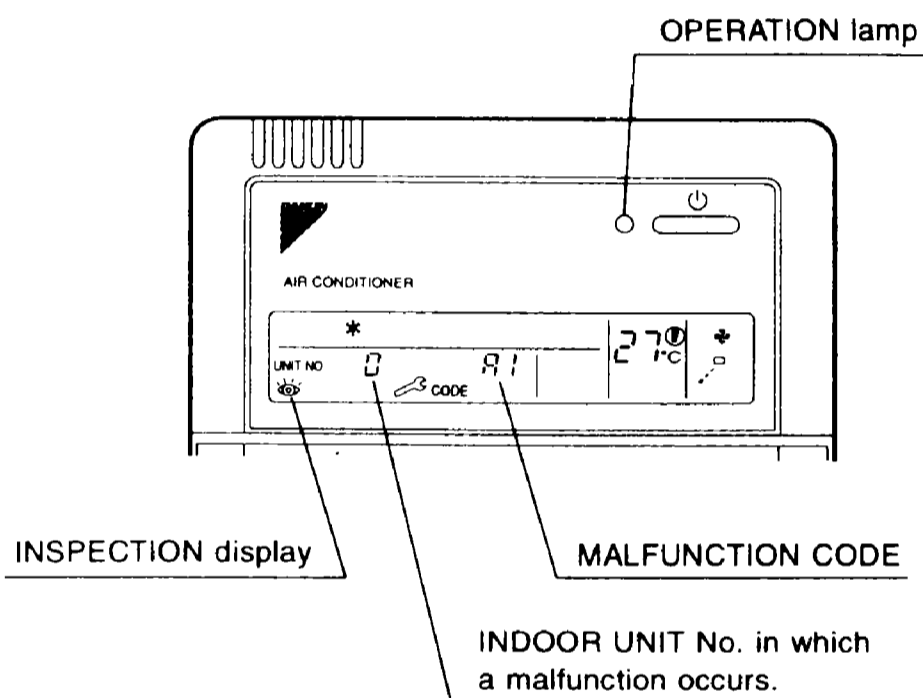
- If a safety device such as a fuse, a breaker, or an earth leakage breaker frequently actuates, or ON/OFF switch does not properly work.

**Measure:** Turn off the main power switch

- If water leaks from unit.

**Measure:** Stop the operation.

- If the display “” (INSPECTION), “UNIT No.”, and the OPERATION lamp flash and the “MALFUNCTION CODE” appears.



**Measure:** Notify your Daikin dealer and inform him/her of the display.

## II. If the system does not properly operate except for the above mentioned case, and none of the above mentioned malfunctions is evident, investigate the system according to the following procedures.

### 1) If the system does not operate at all.

- Check if there is a power failure.  
Wait until power is restored. If power failure occurs during operation, the system automatically restarts immediately after the power supply recovers.
- Check if the fuse has blown or breaker has worked.  
Change the fuse or set the breaker.

### 2) If the system stops operating after operating the system.

- Check if the air inlet or outlet of outdoor or indoor unit is blocked by obstacles.  
Remove the obstacle and make it well-ventilated.
- Check if the air filter is clogged.

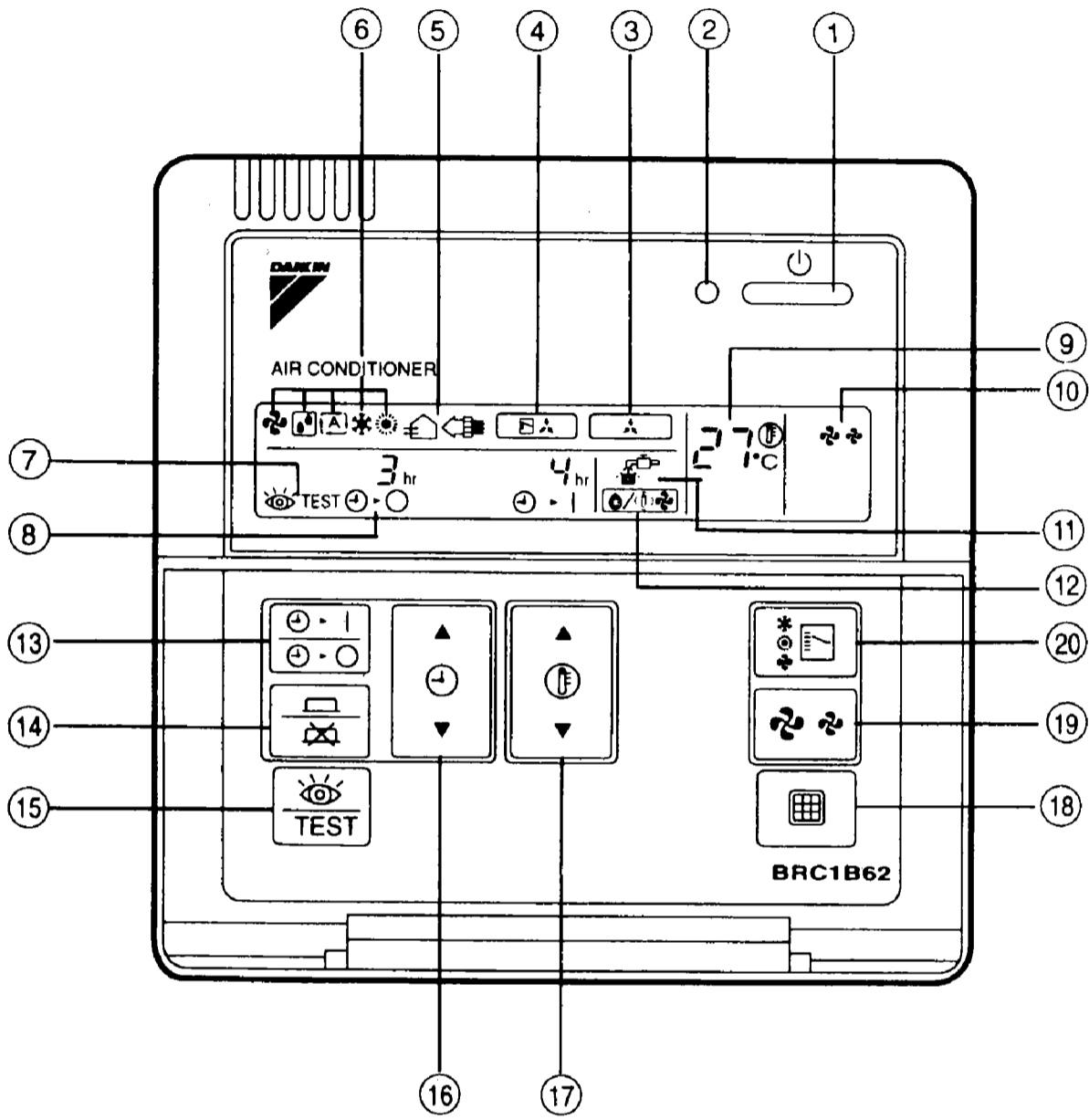
Ask a qualified service person to clean the air filters.

### 3) The system operates but it does not sufficiently cool or heat.

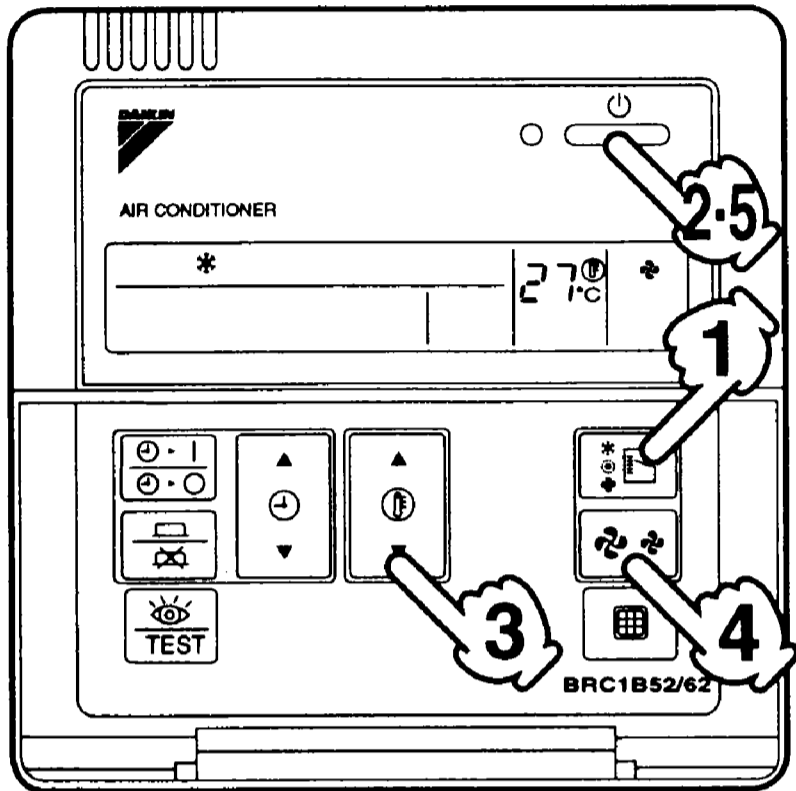
- If the air inlet or outlet of the indoor or the outdoor unit is blocked with obstacles.  
Remove the obstacle and make it well-ventilated.
- If the air filter is clogged.  
Ask a qualified service person to clean the air filters.
- If the set temperature is not proper. (Refer to p. 18)
- If the FAN SPEED button is set to LOW SPEED. (Refer to p. 18)
- If the air flow angle is not proper. (Refer to p. 19)
- If the doors or the windows are open. Shut doors or windows to prevent wind from coming in.
- If direct sunlight enters the room.  
(when cooling)  
Use curtains or blinds.
- When there are too many inhabitants in the room.  
(when cooling)  
Cooling effect decreases if heat gain of the room is too large.
- If the heat source of the room is excessive.  
(when cooling)  
Cooling effect decreases if heat gain of the room is too large.

**BRC1B62** <For FH(Y)B-F, FH-F>

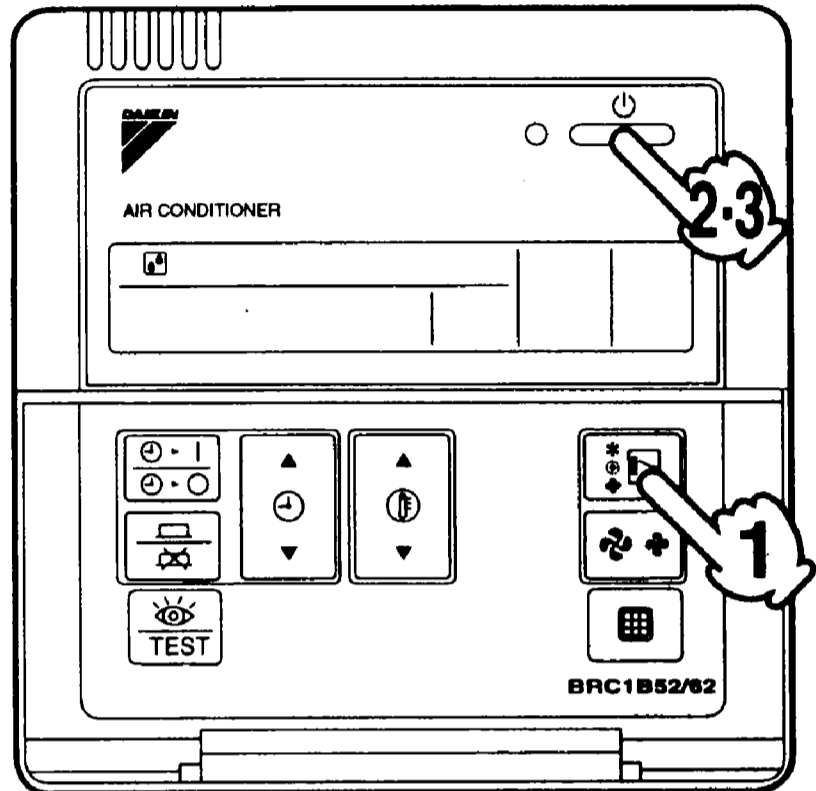
**Fig. 1**



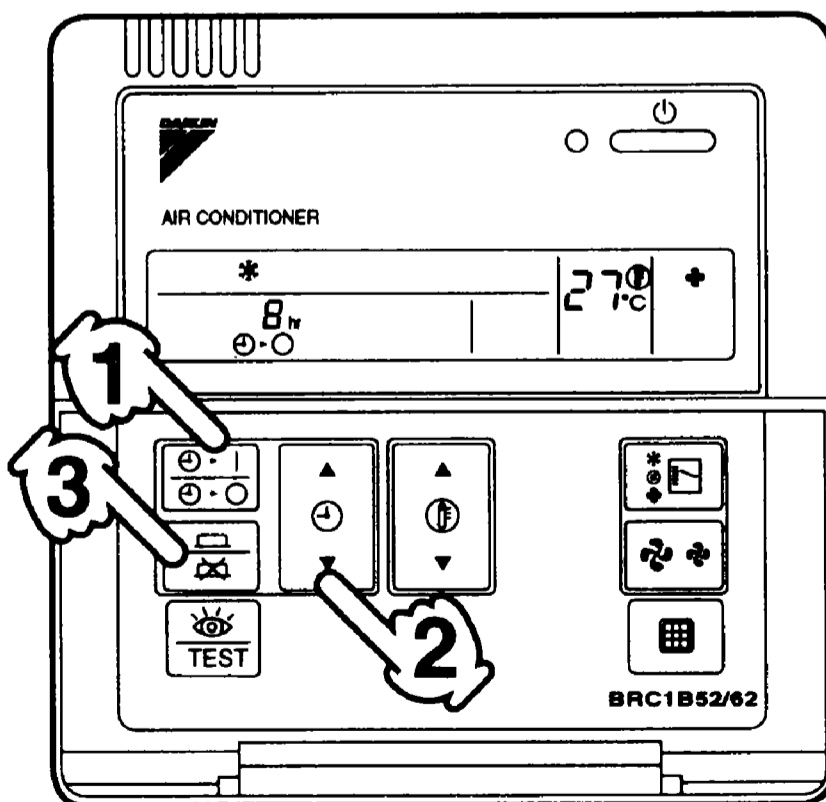
**Fig. 2**



**Fig. 3**



**Fig. 4**



# NAME AND FUNCTION OF EACH SWITCH AND DISPLAY ON THE REMOTE CONTROLLER (Fig. 1)


①	<b>ON/OFF BUTTON</b>	⑫	<b>DISPLAY “/” (DEFROST)</b>
	Press the button and the system will start. Press the button again and the system will stop.		Refer to page 25.
②	<b>OPERATION LAMP (RED)</b>	⑬	<b>TIMER MODE START/STOP BUTTON</b>
	The lamp lights up during operation.		Refer to page 26.
③	<b>DISPLAY “” (UNDER CENTRALIZED CONTROL)</b>	⑭	<b>TIMER ON/OFF BUTTON</b>
	When this display shows, the system is UNDER CENTRALIZED CONTROL. (This is not a standard specification.)		Refer to page 26.
④	<b>DISPLAY “” (CHANGEOVER UNDER CONTROL)</b>	⑮	<b>INSPECTION/TEST OPERATION BUTTON</b>
	This display shows when the outdoor unit is individual operation system.		This button is used only by qualified service persons for maintenance purposes.
⑤	<b>DISPLAY “” (VENTILATION/AIR CLEANING)</b>	⑯	<b>PROGRAMMING TIME BUTTON</b>
	This display shows that the total heat exchange and the air cleaning unit are in operation. (These are optional accessories).		Use this button for programming “START and/or STOP” time.
⑥	<b>DISPLAY “” “” “” (OPERATION MODE)</b>	⑰	<b>TEMPERATURE SETTING BUTTON</b>
	This display shows the current OPERATION MODE. For straight cooling type, “” (Auto) and “” (Heating) are not installed.		Use this button for SETTING TEMPERATURE.
⑦	<b>DISPLAY “ TEST” (INSPECTION/TEST OPERATION)</b>	⑱	<b>FILTER SIGN RESET BUTTON</b>
	When the INSPECTION/TEST OPERATION BUTTON is pressed, the display shows the system mode is in.		
⑧	<b>DISPLAY “” (PROGRAMMED TIME)</b>	⑳	<b>FAN SPEED CONTROL BUTTON</b>
	This display shows PROGRAMMED TIME of the system start or stop.		Press this button to select the fan speed, HIGH or LOW, of your choice.
⑨	<b>DISPLAY “” (SET TEMPERATURE)</b>		<b>OPERATION MODE SELECTOR BUTTON</b>
	This display shows the set temperature.		Press this button to select OPERATION MODE.
⑩	<b>DISPLAY “” (FAN SPEED).</b>		<p>(NOTE)</p> <ul style="list-style-type: none"> <li>For the sake of explanation, all indications are shown on the display in Figure 1 contrary to actual running situations.</li> </ul>
	The display shows the set fan speed.		
⑪	<b>DISPLAY “” (TIME TO CLEAN AIR FILTER)</b>		


# OPERATION PROCEDURE


- Operating procedure varies with heat pump type and straight cooling type. Contact your Daikin dealer to confirm your system type.
- To protect the unit, turn on the main power switch 6 hours before operation.
- If the main power supply is turned off during operation, operation will restart automatically after the power turns back on again.


## COOLING, HEATING, AUTOMATIC, AND FAN OPERATION (Fig. 2)

- 1** Press OPERATION MODE SELECTOR button several times and select the OPERATION MODE of your choice as follows.

COOLING OPERATION ..... "  "

HEATING OPERATION ..... "  "

AUTOMATIC OPERATION ..... "  "

FAN OPERATION ..... "  "

- For straight cooling type, you can select "cooling" and "fan" operation.

### AUTOMATIC OPERATION

In this operation mode, COOL/HEAT changeover is automatically conducted.




- 2** Press ON/OFF button

OPERATION lamp lights up and the system starts OPERATION.

### Adjustment

For programming TEMPERATURE and FAN SPEED, follow the procedure shown below.

- 3** Press TEMPERATURE SETTING button and program the setting temperature.

	Each time this button is pressed, setting temperature rises 1°C.
	
	Each time this button is pressed, setting temperature lowers 1°C.

- The setting is impossible for fan operation.

- 4** Press FAN SPEED CONTROL button.

High or Low fan speed can be selected.


### STOPPING THE SYSTEM

- 5** Press ON/OFF button once again.

OPERATION lamp goes off, and the system stops OPERATION.


## EXPLANATION OF HEATING OPERATION

### DEFROST OPERATION

- As the frost on the coil of an outdoor unit increase, heating effect decreases and the system goes into DEFROST OPERATION.
- The indoor unit fan stops and the remote controller display shows "  "
- After 6 to 8 minutes (maximum 10 minutes) of DEFROST OPERATION, the system returns to HEATING OPERATION.

## PROGRAM DRY OPERATION (Fig. 3)

- The function of this program is to decrease the humidity in your room with the minimum temperature decrease.
- Micro computer automatically determines TEMPERATURE and FAN SPEED.
- This system does not go into operation if the room temperature is below 16°C.

- 1** Press OPERATION MODE SELECTOR button several times and select "  " (PROGRAM DRY OPERATION)

- 2** Press ON/OFF button

OPERATION lamp lights up and the system starts OPERATION.

## STOPPING THE SYSTEM

### 3 Press ON/OFF button again.

OPERATION lamp goes off and the system stops OPERATION.

## PROGRAM TIMER OPERATION (Fig. 4)

- The timer is operated in the following two ways.  
Programming the stop time (⌚▶○) .... The system stops operating after the set time has elapsed.  
Programming the start time (⌚▶|) .... The system starts operating after the set time has elapsed.
- The timer can be programmed a maximum of 72 hours.
- The start and the stop time can be simultaneously programmed.

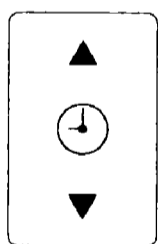
### 1 Press the TIMER MODE START/STOP button several times and select the mode on the display.

The display flashes.

For setting the timer stop .... "⌚▶○"

For setting the timer start ... "⌚▶|"

### 2 Press the PROGRAMMING TIME button and set the time for stopping or starting the system.



When this button is pressed, the time advances by 1 hour.

When this button is pressed, the time goes backward by 1 hour.

### 3 Press the TIMER ON/OFF button.

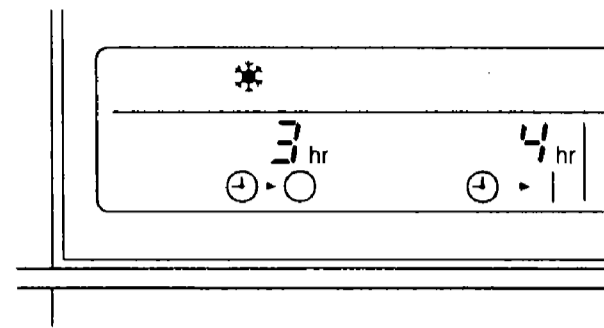
The timer setting procedure ends.

The display "⌚▶○ or ⌚▶|" changes from flashing light to a constant light.

#### NOTE:

- When setting the timer Off and On at the same time, repeat the above procedure from 1 to 3 once again.

For example.



When the timer is programmed to stop the system after 3 hours and start the system after 4 hours, the system will stop after 3 hours and then 1 hour later the system will start.

- After the timer is programmed, the display shows the remaining time.
- Press the TIMER ON/OFF button once again to cancel programming. The display vanishes.

## PRECAUTIONS FOR GROUP CONTROL SYSTEM OR TWO REMOTE CONTROLLER CONTROL SYSTEM

This system provides two other control systems beside individual control (one remote controller controls one indoor unit) system. Confirm the following if your unit is of the following control system type.

#### ■ Group control system

- One remote controller controls up to 16 indoor units.
- All indoor units are equally set.

#### ■ Two remote controller control system

- Two remote controllers control one indoor unit (In case of group control system, one group of indoor units)
- The unit is individually operated.

#### NOTE:

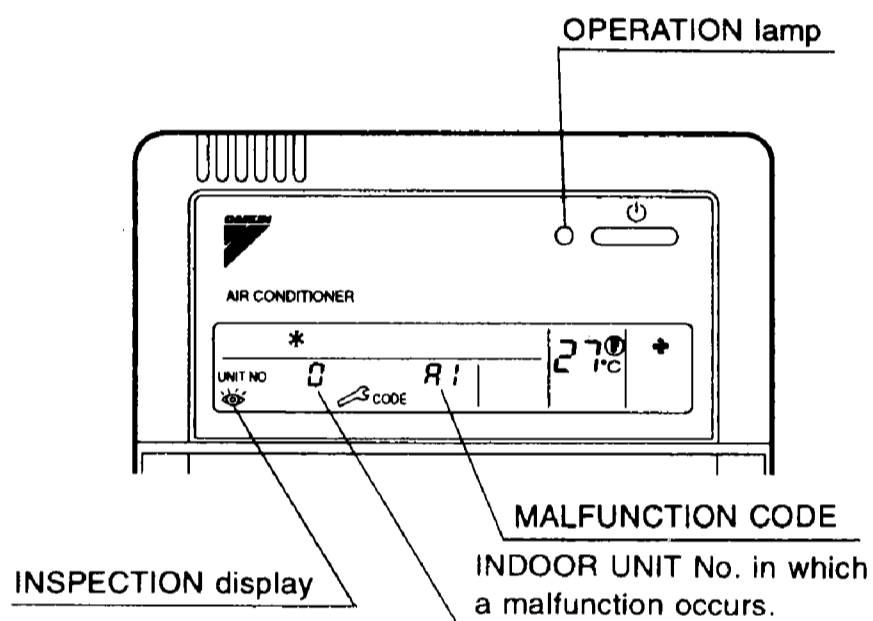
Contact your Daikin dealer if changing the combination or setting of group control and two remote controller control systems.

# TROUBLE SHOOTING

## I. If one of the following malfunctions occurs, take the measures shown below and contact your Daikin dealer.

The system must be repaired by a qualified service person.

- If a safety device such as a fuse, a breaker, or an earth leakage breaker frequently actuates, or ON/OFF switch does not properly work.  
**Measure:** Turn off the main power switch
- If water leaks from unit.  
**Measure:** Stop the operation.
- If the display "👁️" (INSPECTION), "UNIT No.", and the OPERATION lamp flash and the "MALFUNCTION CODE" appears.



**Measure:** Notify your Daikin dealer and inform him/her of the display.

## II. If the system does not properly operate except for the above mentioned case, and none of the above mentioned malfunctions is evident, investigate the system according to the following procedures.

### 1) If the system does not operate at all.

- Check if there is a power failure.  
Wait until power is restored. If power failure occurs during operation, the system automatically restarts immediately after the power supply recovers.
- Check if the fuse has blown or breaker has been tripped.  
Change the fuse or set the breaker.

### 2) If the system stops operating after operation is complete.

- Check if the air inlet or outlet of outdoor or indoor unit is blocked by obstacles.  
Remove the obstacle and make it well-ventilated.
- Check if the air filter is clogged.

Have a qualified service person to clean the air filters.

### 3) The system operates but it does not sufficiently cool or heat.

- If the air inlet or outlet of the indoor or the outdoor unit is blocked with obstacles.  
Remove the obstacle and make it well-ventilated.
- If the air filter is clogged.  
Ask a qualified service person to clean the air filters.
- If the set temperature is not proper. (Refer to p. 25)
- If the FAN SPEED CONTROL button is set to LOW SPEED. (Refer to p. 25)
- If the doors or the windows are open. Shut doors or windows to prevent wind from coming in.
- If direct sunlight enters the room.  
(when cooling)  
Use curtains or blinds.
- When there are too many occupants in the room.  
Cooling effect decreases if heat gain of the room is too large.
- If the heat source of the room is excessive.  
(when cooling)  
Cooling effect decreases if heat gain of the room is too large.

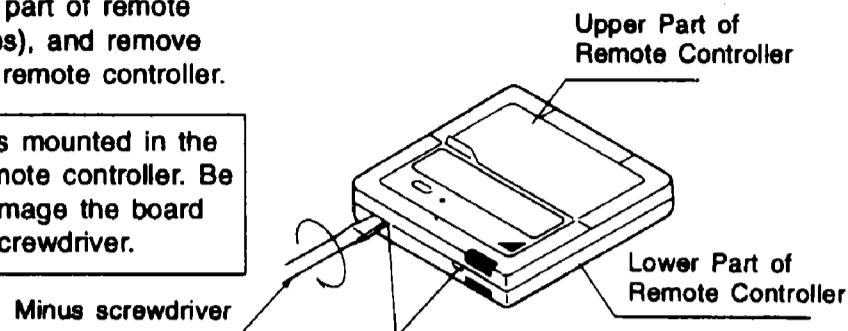


## ★ Installation (BRC1B61-62)

### 1. Remove the upper part of remote controller.

Insert minus screwdriver into the slots in the lower part of remote controller (2 places), and remove the upper part of remote controller.

The P C board is mounted in the upper part of remote controller. Be careful not to damage the board with the minus screwdriver.

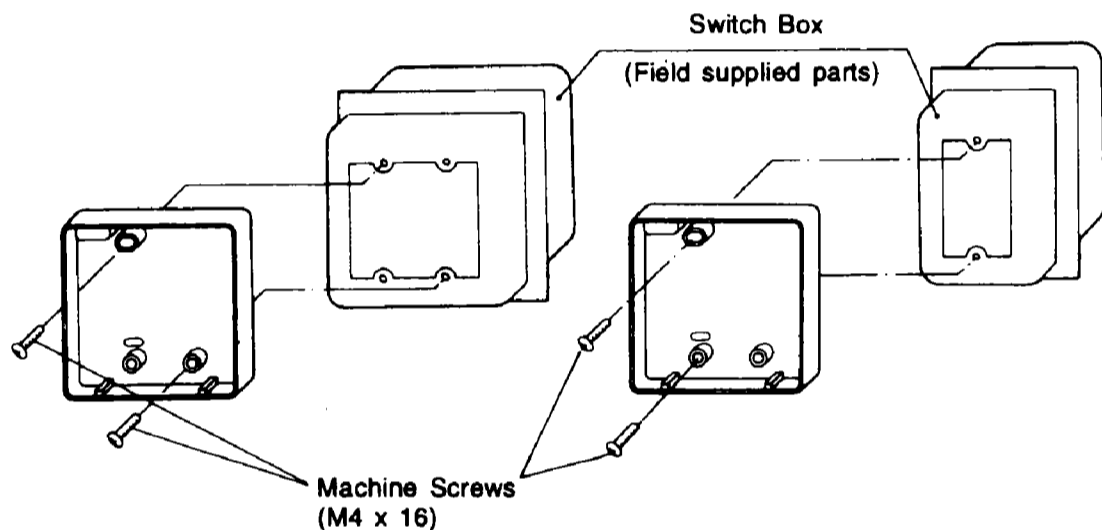
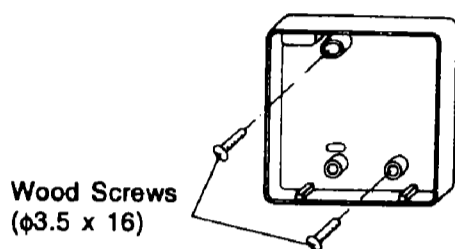


Insert the minus screwdriver and twist lightly to remove.

### 2. Fasten the remote controller.

① For exposed mounting, fasten with the included wood screws (2).

② For flush-mounting, fasten with the included machine screws (2).



For the field supplied switch box, use optional accessories KJB111A or KJB211A.

### NOTE

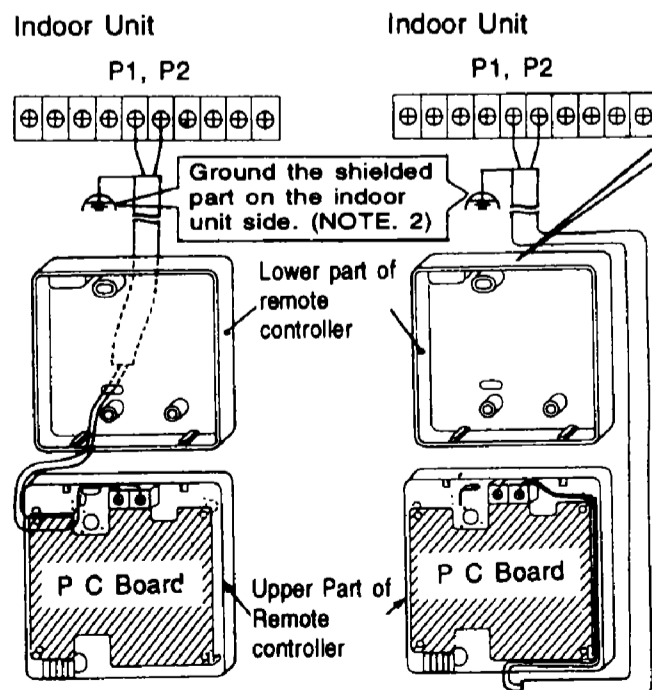
Choose the flattest place possible for the mounting surface. Be careful not to distort the shape of the lower part of remote controller by over-tightening the mounting screws.

### 3. Wire the indoor unit.

Connect the terminals on top of the upper part of remote controller (P1, P2), and the terminals of the indoor unit (P1, P2). (P1 and P2 do not have polarity.)

### NOTE

When wiring, run the wiring away the power supply wiring in order to avoid receiving electric noise (external noise).



(Wired from the rear)

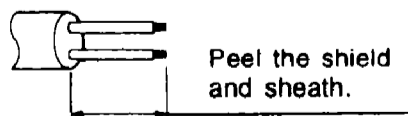
(Wired from the top)

Notch the part for the wiring to pass through with nippers, etc.

### Wiring Specifications

Wiring Type	Sheathed vinyl code or cable (2 wire) (NOTE.2)
Size	0.75 - 1.25 mm <sup>2</sup>

NOTE) 1. Peel the shield and sheath for the part that is to pass through the inside of the remote controller case, as shown in the figure below.



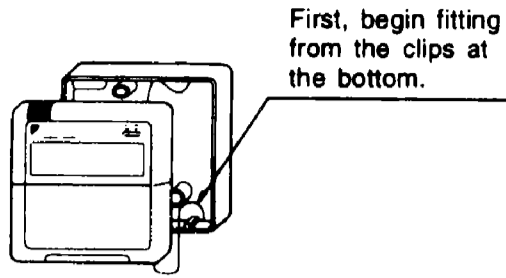
2. Shield wire (2 wire) can be used for remote controller wiring, but it must confirm to EMI (Electromagnetic Interference) code EN55014.

### 4. Reattach the upper part of remote controller.

Be careful not to pinch the wiring when attaching.

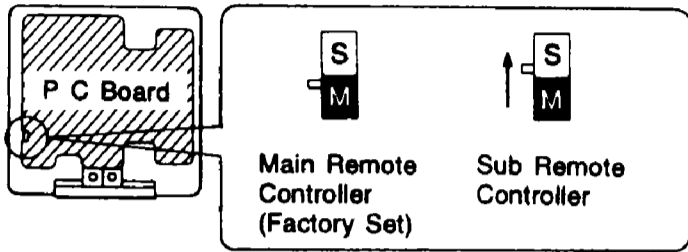
**NOTE**

1. The switch box and wiring for connection are not included.
2. Do not directly touch the PC board with your hand.



**If controlling one indoor unit with two remote controllers**

Change the MAIN/SUB changeover switch setting as described below.



Set one remote controller to "main," and the other to "sub."

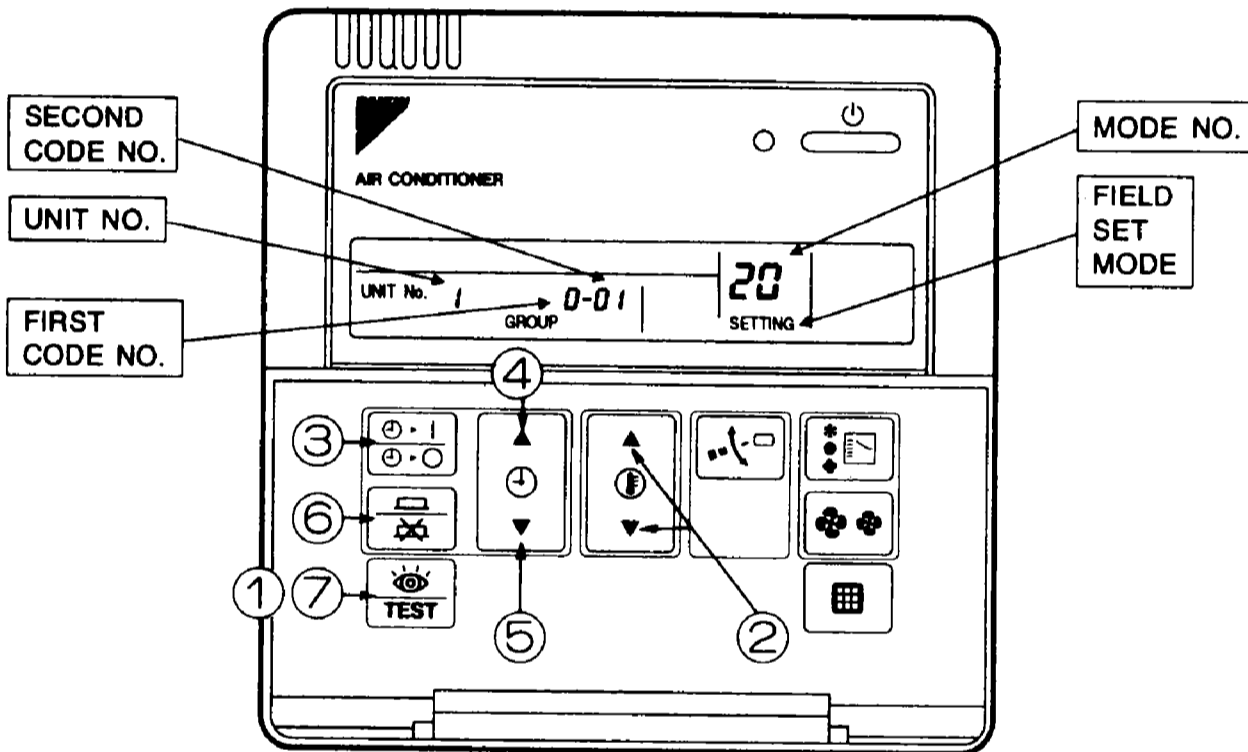
**NOTE**

- If controlling with one remote controller, be sure to set it to "main."
- Set the remote controller before turning power supply on.

"BB" is displayed for about one minute when the power supply is turned on, and the remote controller cannot be operated in some cases.

**FIELD SETTING**

(If optional accessories are mounted on the indoor unit, the indoor unit setting may have to be changed. Refer to the instruction manual for each optional accessory.)



- NOTE) 1. Setting is carried out in the group mode, however, set the mode number inside the ( ) for individual setting of the each indoor unit or confirmation after setting.
2. The SECOND CODE number. is set to "01" when shipped from the factory. However for the following cases it is set to "02".
- Air flow direction range setting.
3. Do not make any settings not given in the table on the left.
4. Not displayed if the indoor unit is not equipped with that function.
5. When returning to the normal mode, "BB" may be displayed in the LCD in order for the remote controller to initialize itself.

**Procedure**

- ① When in the normal mode, press the "TEST" button for a minimum of four seconds, and the FIELD SET MODE is entered.
- ② Select the desired MODE NO. with the "MODE NO." button.
- ③ During group control, when setting by each indoor unit (mode No. 20, 21 and 23 have been selected), push the "GROUP" button and select the INDOOR UNIT NO to be set. (This operation is unnecessary when setting by group.)
- ④ Push the "UP" button and select FIRST CODE NO.
- ⑤ Push the "DOWN" button and select the SECOND CODE NO.
- ⑥ Push the "SET" button once and the present settings are SET.
- ⑦ Push the "TEST" button for about one second to return to the NORMAL MODE.

(Example) If during group setting and the time to clean air filter is set to FILTER CONTAMINATION - HEAVY, SET MODE NO. to "10," FIRST CODE NO. to "0," and SECOND CODE NO. to "02."

Mode No. Note) 1	FIRST CODE NO.	Description of Setting		SECOND CODE NO. Note) 2				
				01		02		03
10(20)	0	Filter Contamination-Heavy/Light (Setting for spacing time of display time to clean air filter) (Setting for when filter contamination is heavy, and spacing time to clean air filter is to be halved)	Long Life Filter	Light	Approx. 2,500 Hrs.	Heavy	Approx. 1,250 Hrs.	—
			Standard Filter		Approx. 200 Hrs.		Approx. 100 Hrs.	
	3	Spacing Time of Display Time to Clean Air Filter Count (Setting for when the filter sign is not to be displayed)		Display		Do Not Display		—
11(21)	0	Setting Number of Connected Skyair Simultaneous Operation System Indoor Units (Setting for Simultaneous Operation System)		Pair		Twin		—
13(23)	0	High Ceiling Setting (Setting for when installed in a ceiling higher than 2.7m)		Normal		High Ceiling 1		High Ceiling 2
	1	Selection of Air Flow Direction (Setting for when a blocking pad kit has been installed)		F		T		W
	3	Air Flow Direction Adjust Function (To be set when decoration panel for air outlet is installed)		Equipped		Not Equipped		—
	4	Air Flow Direction Range Setting		Upper		Normal		Lower
	6	Setting the External Static Pressure (Setting according to the connected duct resistance) (For FHYK, follow the High Ceiling Setting)		Normal (Normal)		High Static Pressure (High Ceiling)		Low Static Pressure —

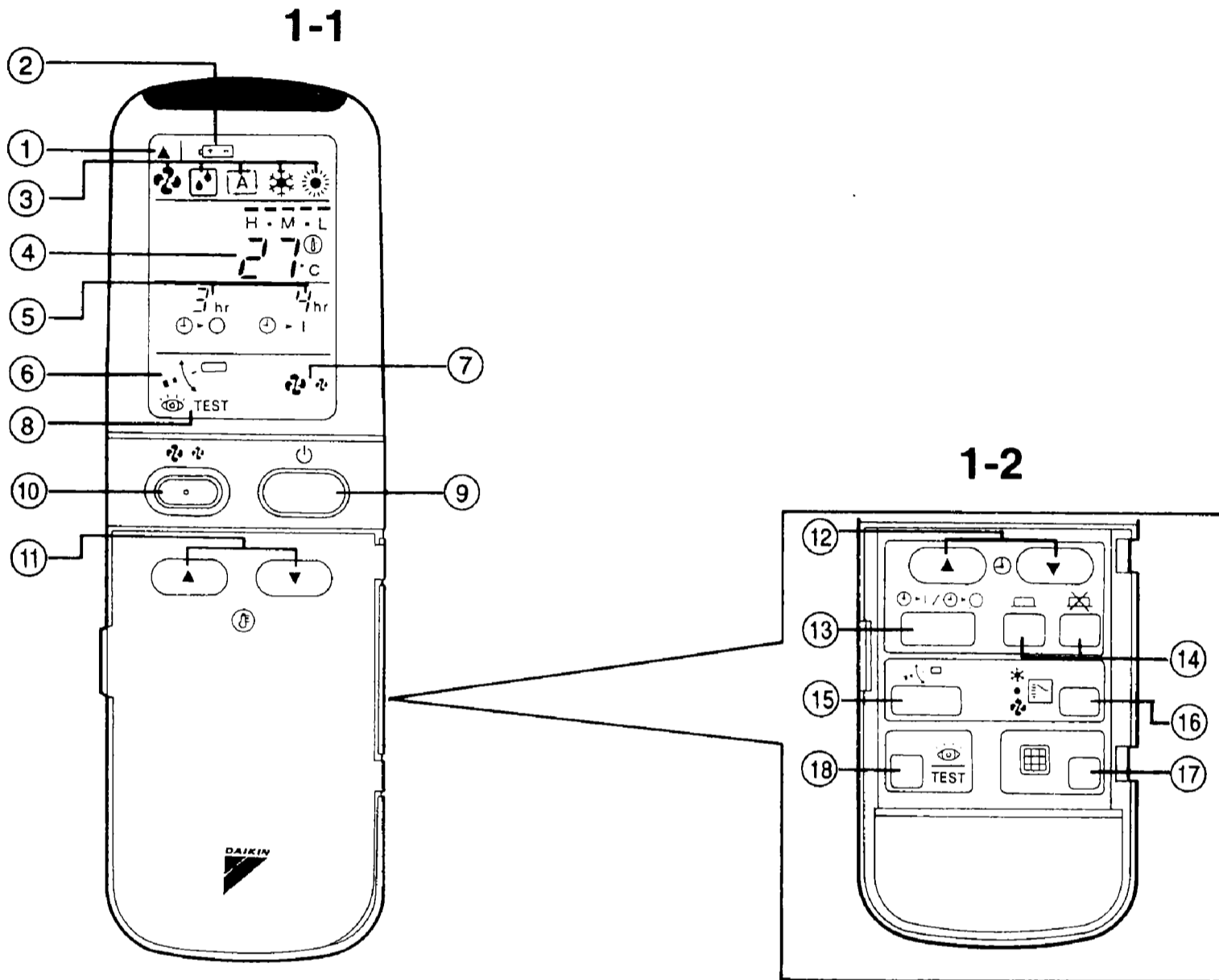
## 1.2 Wireless type

**BRC7A61W** <For FHYC-F>.....Heat Pump

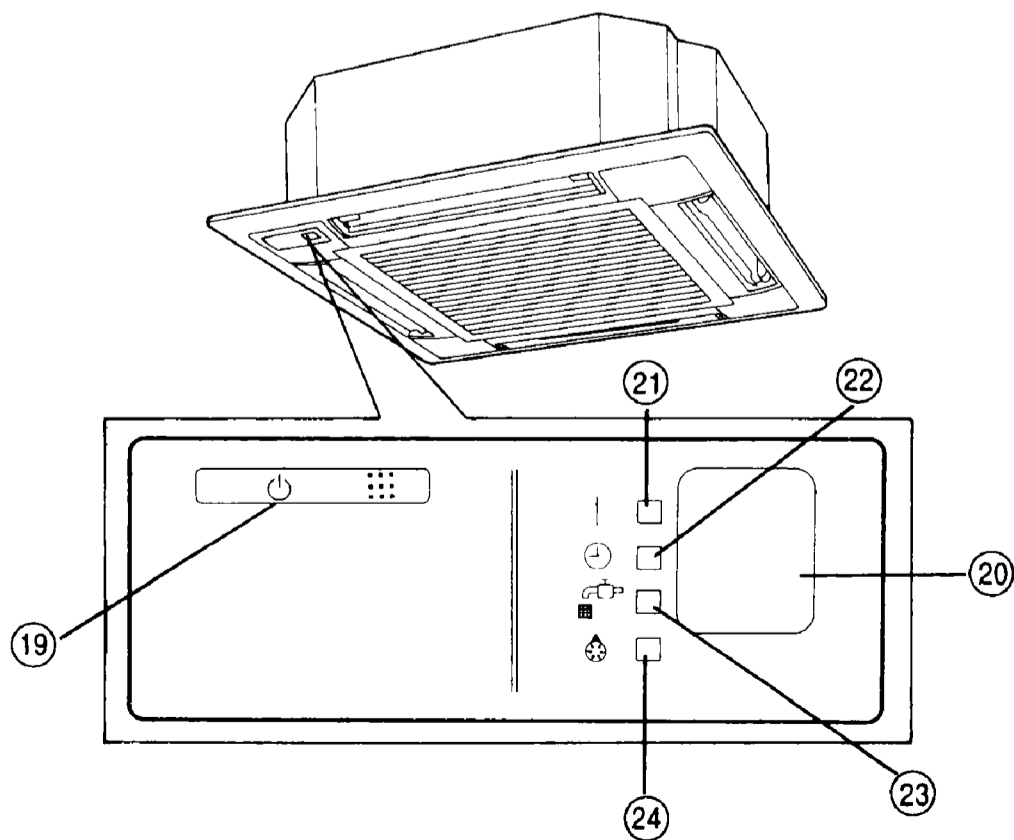
**BRC7A66W** <For FH(Y)C-F>....Cooling Only

### ★ Operation

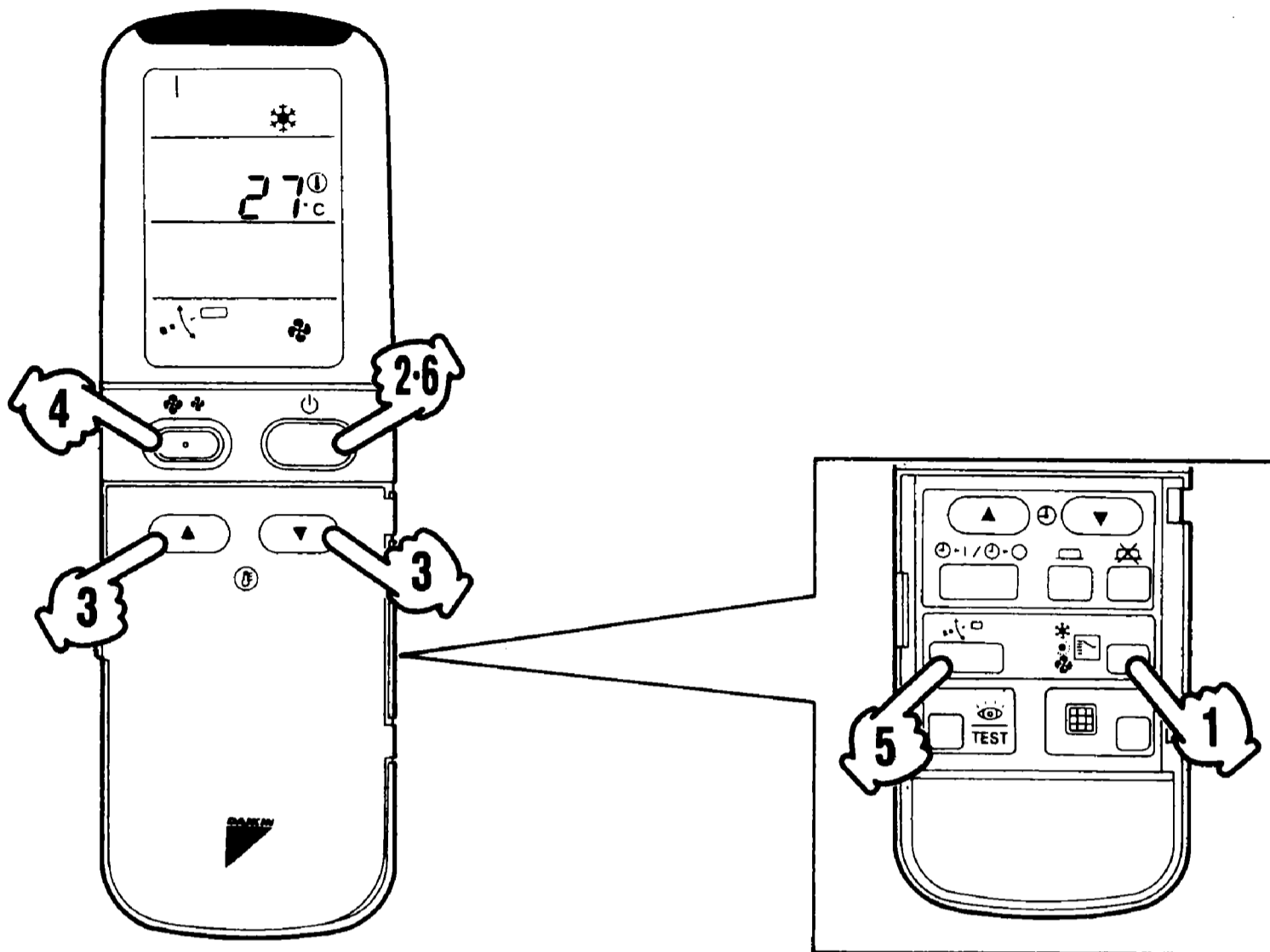
## Fig. 1



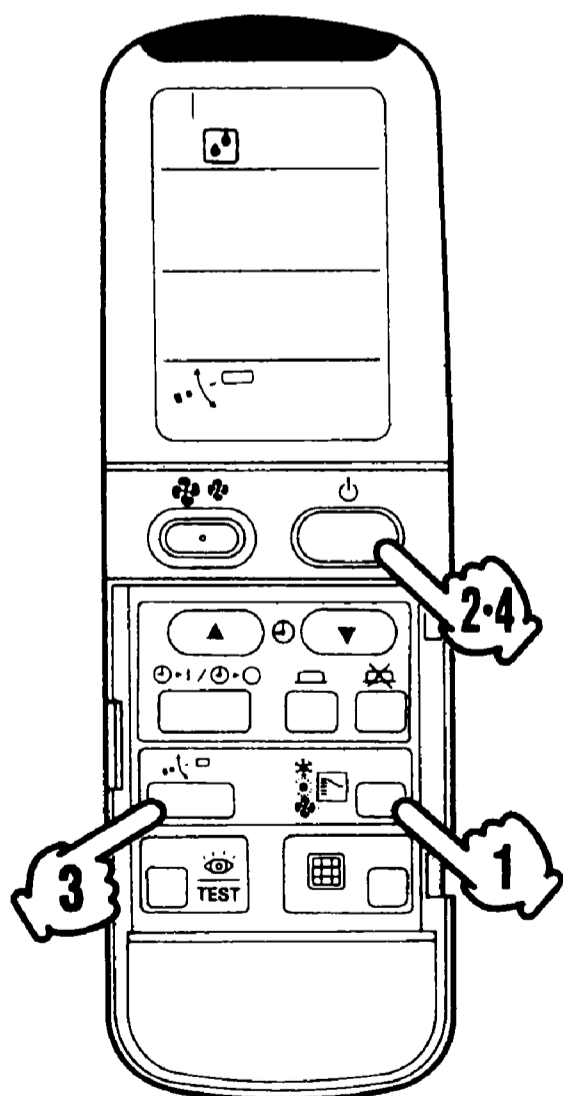
## Fig. 2



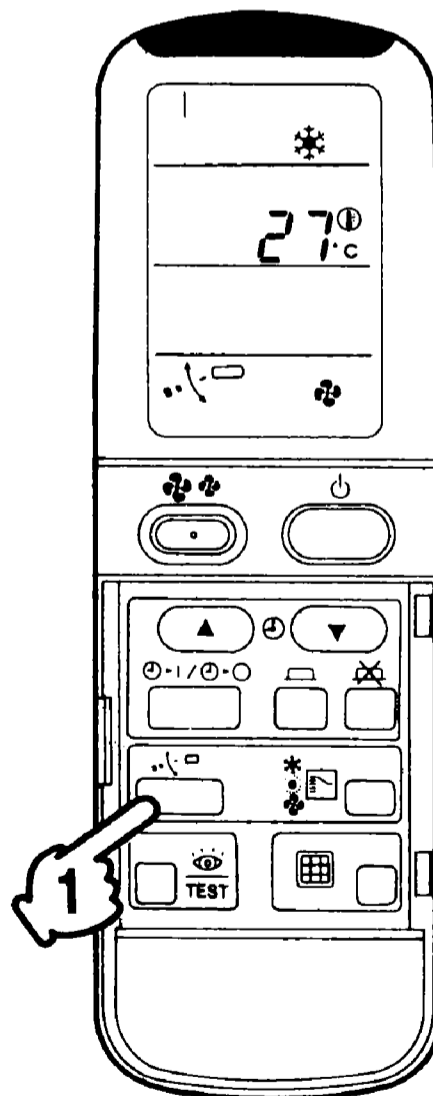
**Fig. 3**



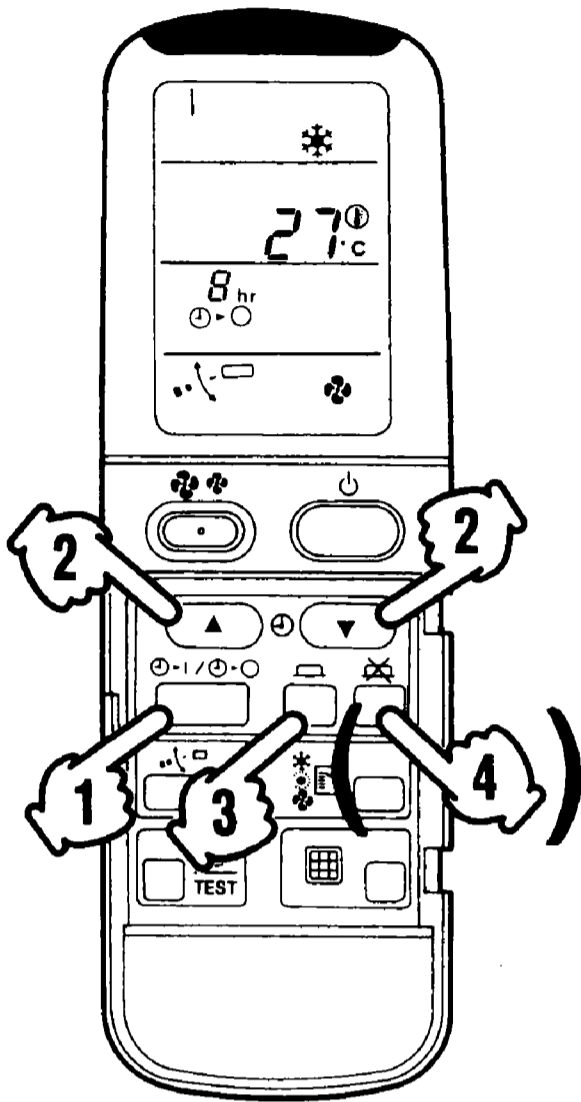
**Fig. 4**



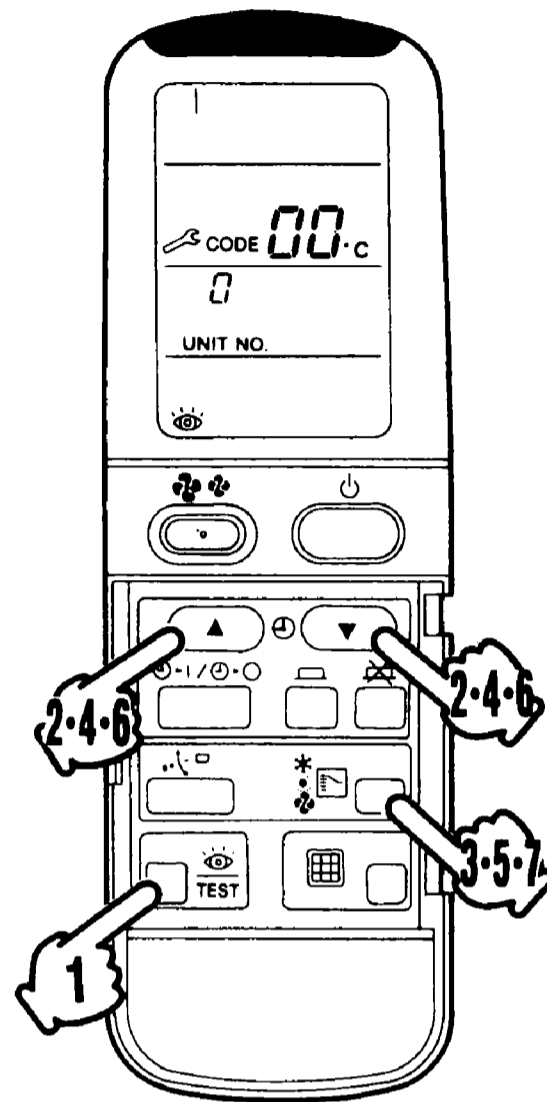
**Fig. 5**



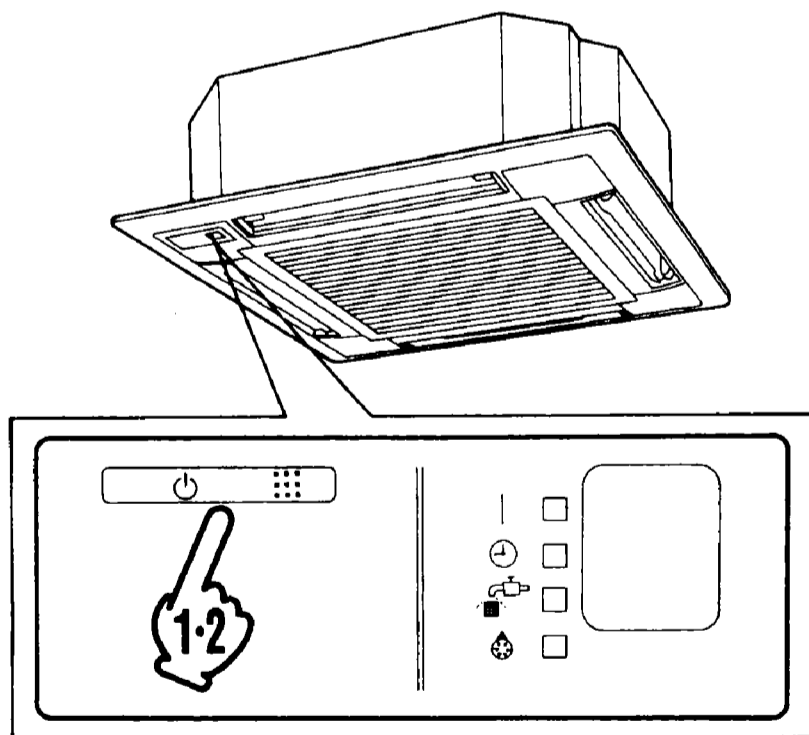
**Fig. 6**



**Fig. 8**



**Fig. 7**



# NAMES AND FUNCTIONS OF THE OPERATING SECTION (Fig. 1, 2)

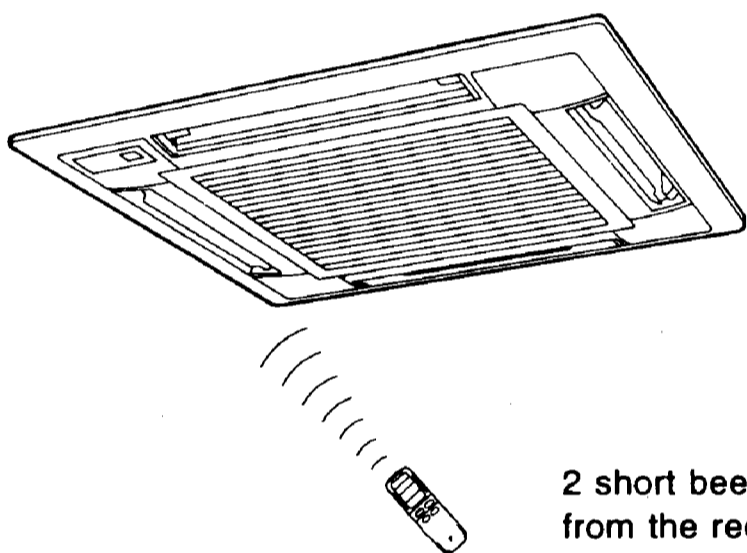
①	<b>DISPLAY “▲” (SIGNAL TRANSMISSION)</b>	⑬	<b>TIMER MODE START/STOP BUTTON</b>
	This lights up when a signal is being transmitted.		Refer to page 38.
②	<b>DISPLAY “+ -” (BATTERY REPLACEMENT DISPLAY)</b>	⑭	<b>TIMER ON/OFF BUTTON</b>
	If this flashes change the batteries.		Refer to page 38.
③	<b>DISPLAY “❁” “⊙” “[A]” “❄” “☀” (OPERATION MODE)</b>	⑮	<b>AIR FLOW DIRECTION ADJUST BUTTON</b>
	This display shows the current OPERATION MODE. For straight cooling type, “[A]” (Auto) and “☀” (Heating) are not installed.		Refer to page 38.
④	<b>DISPLAY “H·M·L” (SET TEMPERATURE) 27°C</b>	⑯	<b>OPERATION MODE SELECTOR BUTTON</b>
	This display shows the set temperature.		Press this button to select OPERATION MODE.
⑤	<b>DISPLAY “3hr 4hr” (PROGRAMMED TIME) ⊕-○ ⊕- </b>	⑰	<b>FILTER SIGN RESET BUTTON</b>
	This display shows PROGRAMMED TIME of the system start or stop.		Refer to the section of MAINTENANCE in the operation manual attached to the indoor unit.
⑥	<b>DISPLAY “↘□” (AIR FLOW FLAP)</b>	⑱	<b>INSPECTION/TEST OPERATION BUTTON</b>
	Refer to page 38.		This button is used only by qualified service persons for maintenance purposes.
⑦	<b>DISPLAY “❁” “❁” (FAN SPEED)</b>	⑲	<b>EMERGENCY OPERATION SWITCH</b>
	The display shows the set fan speed.		This switch is readily used if the remote controller does not work.
⑧	<b>DISPLAY “👁 TEST” (INSPECTION/TEST OPERATION)</b>	⑳	<b>RECEIVER</b>
	When the INSPECTION/TEST OPERATION BUTTON is pressed, the display shows the system mode is in.		This receives the signals from the remote controller.
⑨	<b>ON/OFF BUTTON</b>	㉑	<b>OPERATING INDICATOR LAMP (Red)</b>
	Press the button and the system will start. Press the button again and the system will stop.		This lamp stays lit while the air conditioner runs. It flashes when the unit is in trouble.
⑩	<b>FAN SPEED CONTROL BUTTON</b>	㉒	<b>TIMER INDICATOR LAMP (Green)</b>
	Press this button to select the fan speed, HIGH or LOW, of your choice.		This lamp stays lit while the timer is set.
⑪	<b>TEMPERATURE SETTING BUTTON</b>	㉓	<b>AIR FILTER CLEANING TIME INDICATOR LAMP (Red)</b>
	Use this button for SETTING TEMPERATURE (Operates with the front cover of the remote controller closed.)		Lights up when it is time to clean the air filter.
⑫	<b>PROGRAMMING TIME BUTTON</b>	㉔	<b>DEFROST LAMP (Orange)</b>
	Use this button for programming “START and/or STOP” time. (Operates with the front cover of the remote controller opened.)		Lights up when the defrosting operation has started.
		(NOTE)	
		<ul style="list-style-type: none"> <li>● For the sake of explanation, all indications are shown on the display in Figure 1 contrary to actual running situations.</li> <li>● Fig. 1-2 shows the remote controller with the front cover opened.</li> </ul>	

# HANDLING FOR WIRELESS REMOTE CONTROLLER

## Precautions in handling remote controller

Direct the transmitting part of the remote controller to the receiving part of the air conditioner.

If something blocks the transmitting and receiving path of the indoor unit and the remote controller as curtains, it will not operate.



2 short beeps from the receiver indicates that the transmission is properly done.

Transmitting distance is approximately 7 m.

Do not drop or get it wet.

It may be damaged.

Never press the button of the remote controller with a hard, pointed object.

The remote controller may be damaged.

### Installation site

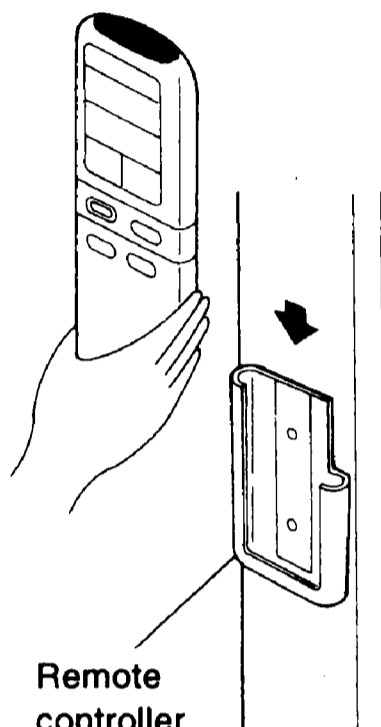
- It is possible that signals will not be received in rooms that have electronic fluorescent lighting. Please consult with the salesman before buying new fluorescent lights.
- If the remote controller operated some other electrical apparatus, move that machine away or consult your dealer.

## Placing the remote controller in the remote controller holder

Install the remote controller holder to a wall or a pillar with the attached screw. (Make sure it transmits)

### Placing the remote controller

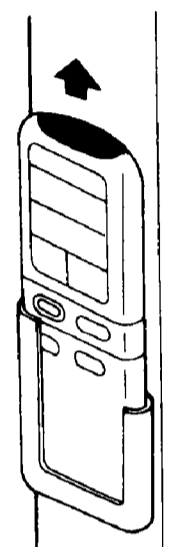
Slide from above



Remote controller holder

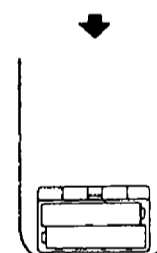
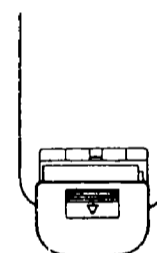
### Removing the remote controller

Pull it upward



## How to put the dry batteries

- ① Remove the back cover of the remote controller to the direction pointed by the arrow mark.
- ② Pull in batteries  
Use two LRO3<IEC> dry cell batteries. Pull dry batteries correctly to fit their (+) and (-).
- ③ Close the cover



## CAUTIONS

- Replace all batteries at the same time, do not use new and old batteries intermixed.
- In case the remote controller is not used for a long time take out all batteries in order to prevent liquid leak of the battery.
- Under normal use the batteries should last for 1 year.



## IN THE CASE OF CENTRALIZED CONTROL SYSTEM

- If the indoor unit is under centralized control, it is necessary to switch the remote controller's setting switch (A, B) to "B". In this case, refer to "PRECAUTIONS AT CENTRALIZED CONTROL" (p. 40). (Contact your DAIKIN dealer to find out whether your system is a centralized control type.)


# OPERATION PROCEDURE


- Operating procedure varies with heat pump type and straight cooling type. Contact your Daikin dealer to confirm your system type.
- To protect the unit, turn on the main power switch 6 hours before operation.
- If the main power supply is turned off during operation, operation will restart automatically after the power turns back on again.


---


## COOLING, HEATING, AUTOMATIC, AND FAN OPERATION (Fig. 3)


---

 **Press OPERATION MODE SELECTOR button several times and select the OPERATION MODE of your choice as follows.**

COOLING OPERATION ..... "  "

HEATING OPERATION ..... "  "

AUTOMATIC OPERATION ..... "  "

FAN OPERATION ..... "  "

- For straight cooling type, "cooling" and "fan" operation are able to select.

### AUTOMATIC OPERATION

- In this operation mode, COOL/HEAT changeover is automatically conducted.



 **Press ON/OFF button**

OPERATION lamp lights up and the system starts OPERATION.



### Adjustment

For programming TEMPERATURE, FAN SPEED and AIR FLOW DIRECTION, follow the procedure shown below.

**3** Press **TEMPERATURE SETTING** button and program the setting temperature.

-  Each time this button is pressed, setting temperature rises 1°C.
-  Each time this button is pressed, setting temperature lowers 1°C.

### In case of automatic operation

-  Each time this button is pressed, setting temperature shifts to "H" side.
-  Each time this button is pressed, setting temperature shifts to "L" side.

[°C]

	H	•	M	•	L
Setting temperature	25	23	22	21	19

- The setting is impossible for fan operation.

NOTE) In case of Cooling and Heating operation, the setting temperature range of the remote controller is 16°C ~ 32°C.

**4** Press **FAN SPEED CONTROL** button.

High or Low fan speed can be selected.

**5** Press **AIR FLOW DIRECTION** button

Refer to "ADJUSTING THE AIR FLOW DIRECTION" (p. 38) for details.

### STOPPING THE SYSTEM

**6** Press **ON/OFF** button once again.

OPERATION lamp goes off, and the system stops OPERATION.


## EXPLANATION OF HEATING OPERATION

### DEFROST OPERATION

- As the frost on the coil of an outdoor unit increase, heating effect decreases and the system goes into DEFROST OPERATION.
- The fan operation stops and the DEFROST lamp of the indoor unit goes on.  
After 6 to 8 minutes (maximum 10 minutes) of DEFROST OPERATION, the system returns to HEATING OPERATION.

## PROGRAM DRY OPERATION (Fig. 4)

- The function of this program is to decrease the humidity in your room with the minimum temperature decrease.
- Micro computer automatically determines TEMPERATURE and FAN SPEED.
- This system does not go into operation if the room temperature is below 16°C.

**1** Press **OPERATION MODE SELECTOR** button several times and select " " (PROGRAM DRY OPERATION)

**2** Press **ON/OFF** button

OPERATION lamp lights up and system starts OPERATION.

### Adjustment

**3** Press **AIR FLOW DIRECTION ADJUST** button.

Refer to "ADJUSTING THE AIR FLOW DIRECTION" (p. 38) for details.

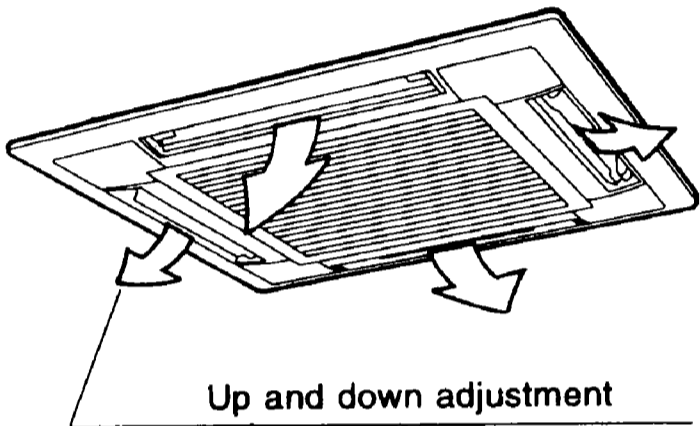
## STOPPING THE SYSTEM

### 4 Press ON/OFF button again.

OPERATION lamp goes off and the system stops OPERATION.


## ADJUSTING THE AIR FLOW DIRECTION (Fig. 5)

Press the AIR FLOW DIRECTION ADJUST button to adjust the air flow angle.




- The movable limit of the blade is changeable. Contact your Daikin dealer for details.

### 1 Press the AIR FLOW DIRECTION ADJUST button to select the air direction as shown below.

" " DISPLAY appears and the air flow direction continuously varies. (Automatic swing setting)



Press AIR FLOW DIRECTION ADJUST button to select the air direction of your choice.

" " DISPLAY vanishes and the desired air flow direction is fixed. (Fixed air flow setting)




## MOVEMENT OF THE AIR FLOW FLAP

For the following conditions, micro computer controls the air flow direction so it may be different from the display.

Operation mode	Cooling	Heating
Operation conditions	<ul style="list-style-type: none"> <li>When room temperature is lower than the set temperature</li> </ul>	<ul style="list-style-type: none"> <li>When room temperature is higher than the set temperature</li> <li>At defrost operation</li> </ul>
	<ul style="list-style-type: none"> <li>When operating continuously at horizontal air flow direction</li> </ul>	

Operation mode includes automatic operation.

## PROGRAM TIMER OPERATION (Fig. 6)

- The timer is operated in the following two ways. Programming the stop time (  >  ). . . . The system stops operating after the set time has elapsed. Programming the start time (  > | ). . . . The system starts operating after the set time has elapsed.
- The timer can be programmed a maximum of 72 hours.
- The start and the stop time can be simultaneously programmed.

### 1 Press the TIMER MODE START/STOP button several times and select the mode on the display

The display flashes.

For setting the timer stop . . . . . (  >  )

For setting the timer start . . . . . (  > | )

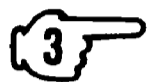
### 2 Press the PROGRAMMING TIME button and set the time for stopping or starting the system.



When this button is pressed, the time advances by 1 hour.



When this button is pressed, the time goes backward by 1 hour.





### Press TIMER ON button.

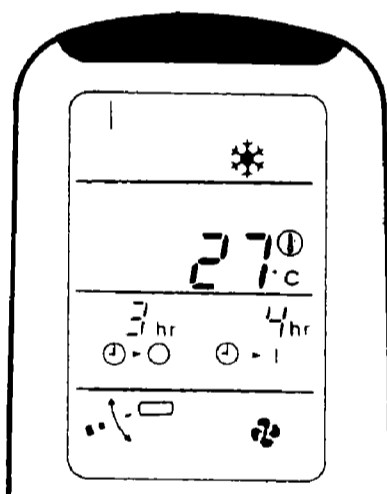
The timer setting procedure ends.

The display or changes from flashing light to a constant light.


#### NOTE

- When setting the timer Off and On at the same time, repeat the above procedure from  to  once again.

For example.



When the timer is programmed to stop the system after 3 hours and start the system after 4 hours, the system will stop after 3 hours and then 1 hour later the system will start.

- After the timer is programmed, the display shows the remaining time.
- Press the TIMER OFF button to cancel programming. The display vanishes. ()

## EMERGENCY OPERATION (Fig. 7)

When the remote controller does not work due to dead batteries or it is missing, use this switch which is located beside the discharge grille on the main unit. When the remote controller does not work, but the battery low indicator on it is not lit, contact your dealer.

### START



### Press the EMERGENCY OPERATION switch.

The machine runs in the previous mode.

The system operates with the previously set air flow direction.

### STOP



### Press the EMERGENCY OPERATION switch again.

## PRECAUTIONS FOR GROUP CONTROL SYSTEM OR TWO REMOTE CONTROLLER CONTROL SYSTEM

This system provides two other control systems beside individual control (one remote controller controls one indoor unit) system. Confirm the following if your unit is of the following control system type.

#### ■ Group control system

One remote controller controls up to 16 indoor units.

All indoor units are equally set.

#### ■ Two remote controller control system

Two remote controllers control one indoor unit. (In case of group control system, one group of indoor units)

The unit follows individual operation.

#### NOTE:

- Cannot have two remote controller control system with only wireless remote controllers. (It will be a two remote controller control system having one wired and one wireless remote controllers.)

- Under two remote controller control system, wireless remote controller cannot control timer operation.
- Only the operating indicator lamp out of 3 other lamps on the indoor unit display functions.

**NOTE:**

Contact your Daikin dealer in case of changing the combination or setting of group control and two remote controller control systems.

---

## PRECAUTIONS AT CENTRALIZED CONTROL

---

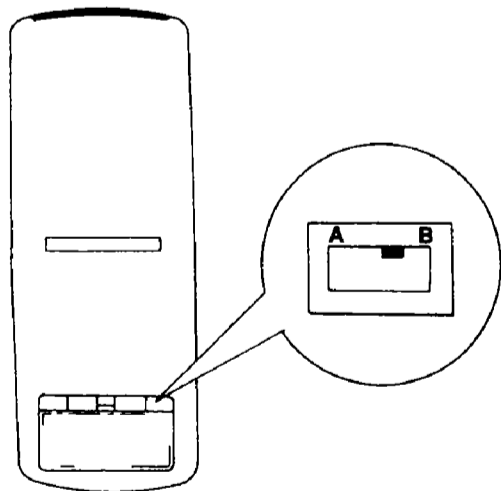
- If the indoor unit is under centralized control, the operation using the remote controller becomes limited and controls fewer functions.
- The display of the remote controller indicates only the changed setting and it will vanish after few seconds.

⟨⟨ If the above-mentioned operation is not carried out, switch the remote controller's setting switch to "B." ⟩⟩  
(Setting Method)

Switch the setting switch to "B."

Operation may not be accepted if the switch remains set to "A" (factory set).

Return the switch to "A" if you want to change to individual control (standard control).



- **In case the setting which is under centralized control is chosen:**

The RECEIVER of the indoor unit makes three short beeps meaning the operation is not accepted.

- **If the operation allowing use of remote controllers is chosen:**

The RECEIVER of the indoor unit makes two short beeps meaning the operation is accepted.

# NOT MALFUNCTION OF THE AIR CONDITIONER

## The following symptoms do not indicate air conditioner malfunction

### I. THE SYSTEM DOES NOT OPERATE

- **The system does not restart immediately after the ON/OFF button is pressed.**

If the OPERATION lamp lights, the system is in normal condition. It does not restart immediately because a safety device operates to prevent overload of the system. After 3 minutes, the system will turn on again automatically.

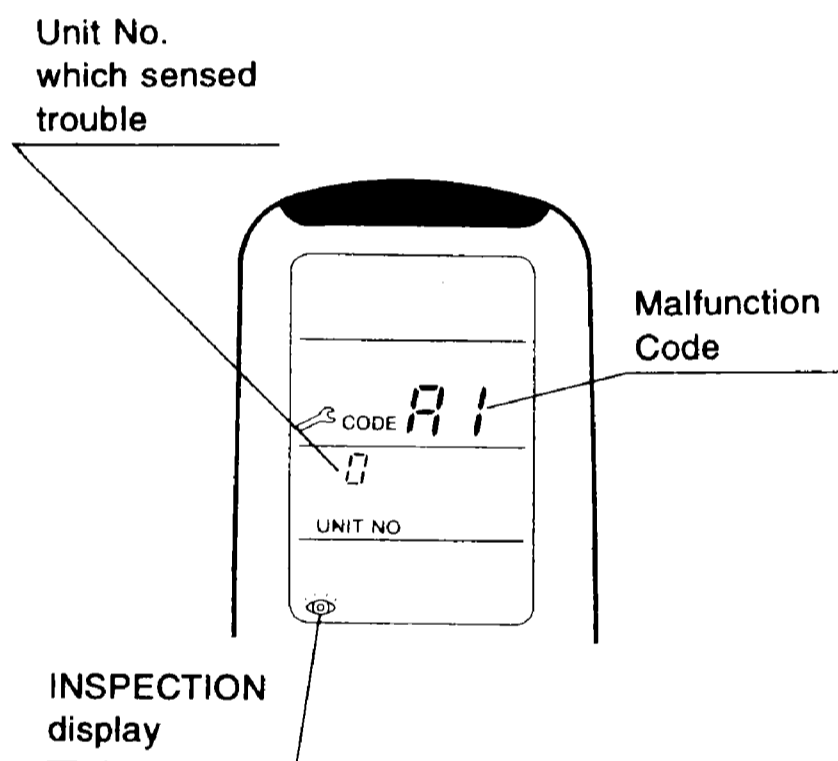
- **The system does not restart immediately when TEMPERATURE SETTING button is returned to the former position after pushing the button.**

It does not restart immediately because a safety device operates to prevent overload of the system. After 3 minutes, the system will turn on again automatically.

# HOW TO DIAGNOSE TROUBLE SPOTS (Fig. 8)

## I. EMERGENCY STOP

When the air conditioner stops in emergency, the run lamp on the indoor unit starts blinking. Take the following steps yourself to read the malfunction code that appears on the display. Contact your dealer with this code. It will help pinpoint the cause of the trouble, speeding up the repair.



**1** Press the **INSPECTION/TEST** button to select the inspection mode "□".

"□" appears on display and blinks. "UNIT" lights up.

**2** Press **PROGRAMMING TIMER** **BUTTON** and change the unit number.

Press to change the unit number until the indoor unit beeps and perform the following operation according to the number of beeps.

### Number of beeps

- 3 short beeps . . . . . Perform all steps from **3** to **6**
- 1 short beep . . . . . Perform **3** and **6** steps
- 1 long beep . . . . . Normal state

**3** Press **OPERATION MODE** **SELECTOR** **BUTTON**

"□" on the left-hand of the malfunction code blinks.

**4** Press **PROGRAMMING** **TIMER** **BUTTON** and change the malfunction code.

Press until the indoor unit beeps twice.

**5** Press **OPERATION** **MODE** **SELECTOR** **BUTTON**

"□" on the right-hand of the malfunction code blinks.

**6** Press **PROGRAMMING** **TIMER** **BUTTON** and change the malfunction code.

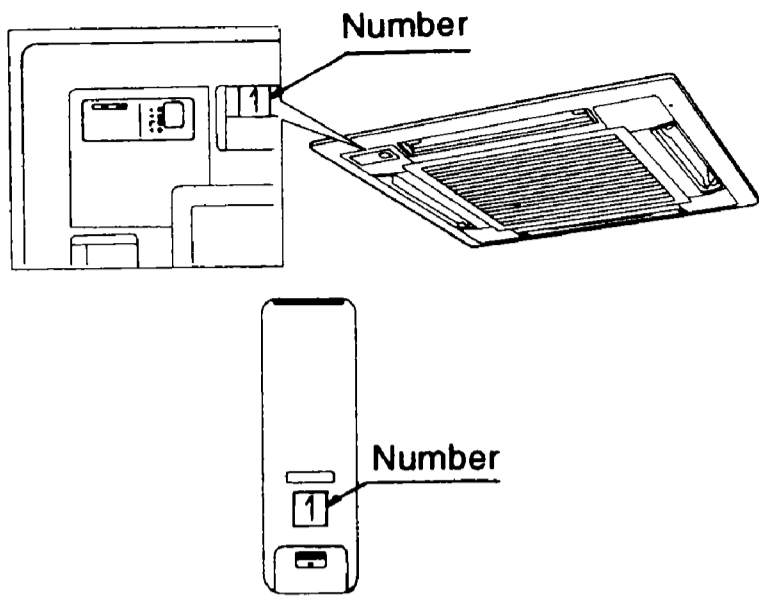
Press until the indoor unit makes a long beep. The malfunction code is fixed when the indoor unit makes a long beep.

**7** **Reset of the display**

Press **OPERATION** **MODE** **SELECTOR** **BUTTON** to get the display back to the normal state.

## II. IN CASE BESIDES EMERGENCY STOP

1. **The unit does not operate at all.**
  - Check if the receiver is exposed of sunlight or strong light. Keep receiver away from light.
  - Check if there are batteries in the remote controller. Place the batteries.
  - Check if the indoor unit number and wireless remote controller number are equal.



Operate the indoor unit with the remote controller of the same number.

Signal transmitted from a remote controller of a different number cannot be accepted. (If the number is not mentioned, it is considered as "1")

**2. The system operates but it does not sufficiently cool or heat.**

- If the set temperature is not proper.
- If the FAN SPEED is set to LOW SPEED.
- If the air flow angle is not proper.

## ★ Installation

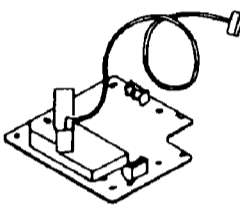
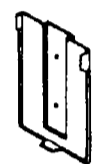

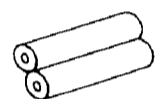
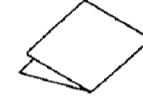
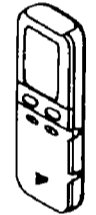
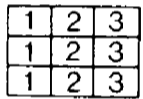


# BEFORE INSTALLATION

### PRECAUTIONS

- Refer also to the installation manual attached to the indoor unit and the installation manual attached to the decoration panel.
- Confirm that following conditions are satisfied prior to installation.
  - Ensure that nothing interrupts the operation of the wireless remote controller. (Ensure that there is neither a source of light nor fluorescent lamp near the receiver. Also, ensure that the receiver is not exposed of direct sun light.)
  - Ensure that the operation display lamp and other indicators are easy to see.
- The installation position of this kit is 1 position of the decoration panel. Therefore, confirm that its position is set so that the signal from the wireless remote controller can be easily transmitted and its display can be easily seen.
- If both this kit and fresh air intake kit are installed, only one duct chamber shall be used. Refer to the installation manual of the fresh air intake kit (optional hand book).

### ACCESSORIES

Check if the following accessories are included with your unit.

Name	Shape	Quantity	Name	Shape	Quantity	Name	Shape	Quantity
Receiver		1 set	Remote controller holder		1 pc.	Screw for installing remote controller holder		2 pcs.
			Dry cell battery LR03 (AM4)		2 pcs.	Operation manual		1 pc.
Wireless remote controller		1 pc.	Unit No. label		1 pc.	Sealing pad	 20 x 35	1 pc.
			Binding band		1 pc.			

### NOTE TO THE INSTALLER

Be sure to instruct the customer how to properly operate the system showing him/her the attached operation manual.

## REMOTE CONTROLLER INSTALLATION

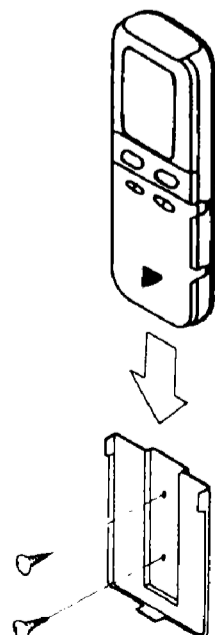
### < Installing wireless remote controller >

- Do not throw the remote controller or impose large shocks. Also, do not store where it may be exposed to moisture or direct sunlight.
- When operating, point the transmitting part of the remote controller in the direction of the receiver.
- The direct transmitting distance of the remote controller is approximately 7 meters.
- The signal cannot be transmitted if something such as curtains blocks the receiver and the remote controller.

#### • Installing to a wall or a pillar

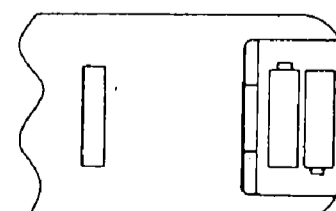
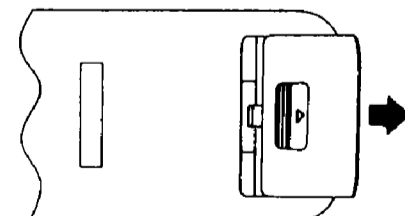
Slide the remote controller into the remote controller holder from the top.

Fix the remote controller holder with the screws.



#### • How to insert the batteries

- ① Open the back cover of the remote controller by sliding it in the direction of the arrow.
- ② Insert the attached dry cell batteries. Properly insert, set the batteries by matching the (+) and (-) polarity marks as indicated. Then close the cover as before.





# RECEIVER INSTALLATION

## (1) Preparations before installation

Install this kit after installing the decoration panel.

- ① Remove the suction grille and the air filter according to the instructions in the installation manual attached to the decoration panel.
- ② Remove the control box lid according to the instructions in the installation manual attached to the indoor unit.

## (2) Determination of address and MAIN/SUB remote controller.

If setting multiple wireless remote controllers to operate in one room, perform address setting for the receiver and the wireless remote controller. If setting multiple wired remote controllers in one room, change the MAIN/SUB switch of the receiver.

### SETTING PROCEDURE

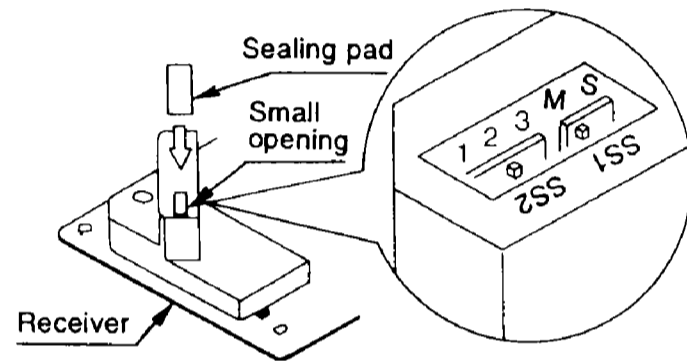
#### ① Setting the receiver

Through the small opening on the back of the receiver, set the wireless address switch (SS2) on the printed circuit board according to the table below.

Unit No.	No. 1	No. 2	No. 3
Wireless address switch (SS2)	1 2 3	1 2 3	1 2 3

When using both a wired and a wireless remote controller for 1 indoor unit, the wired controller should be set to MAIN. Therefore, set the MAIN/SUB switch (SS1) of the receiver to SUB.

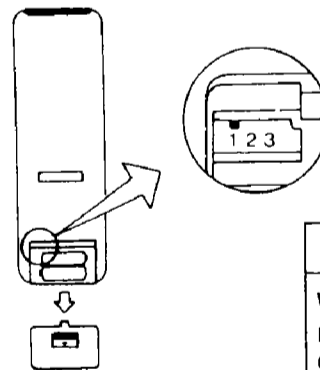
	MAIN	SUB
MAIN/SUB switch (SS1)	S M	S M



**After completing setting, seal off the opening of the address switch and the MAIN/SUB switch with the attached sealing pad.**

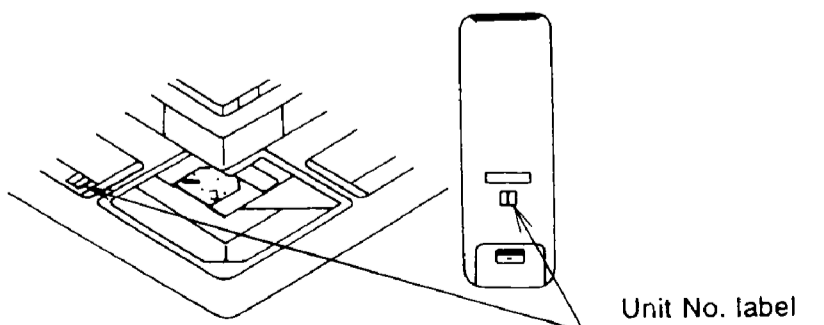
#### ② Setting the address of wireless remote controller (It is factory set to "1")

Remove the back cover on the wireless remote controller and set the wireless remote controller address switch according to drawing.



Unit No.	No. 1	No. 2	No. 3
Wireless remote controller address switch	1 2 3	1 2 3	1 2 3

- ③ Stick the Unit No. label on the air outlet of the decoration panel and the back of the wireless remote controller.



#### PRECAUTIONS

Set the Unit No. of the receiver and the wireless remote controller to be equal. If the settings differs, the signal from the remote controller cannot be transmitted.

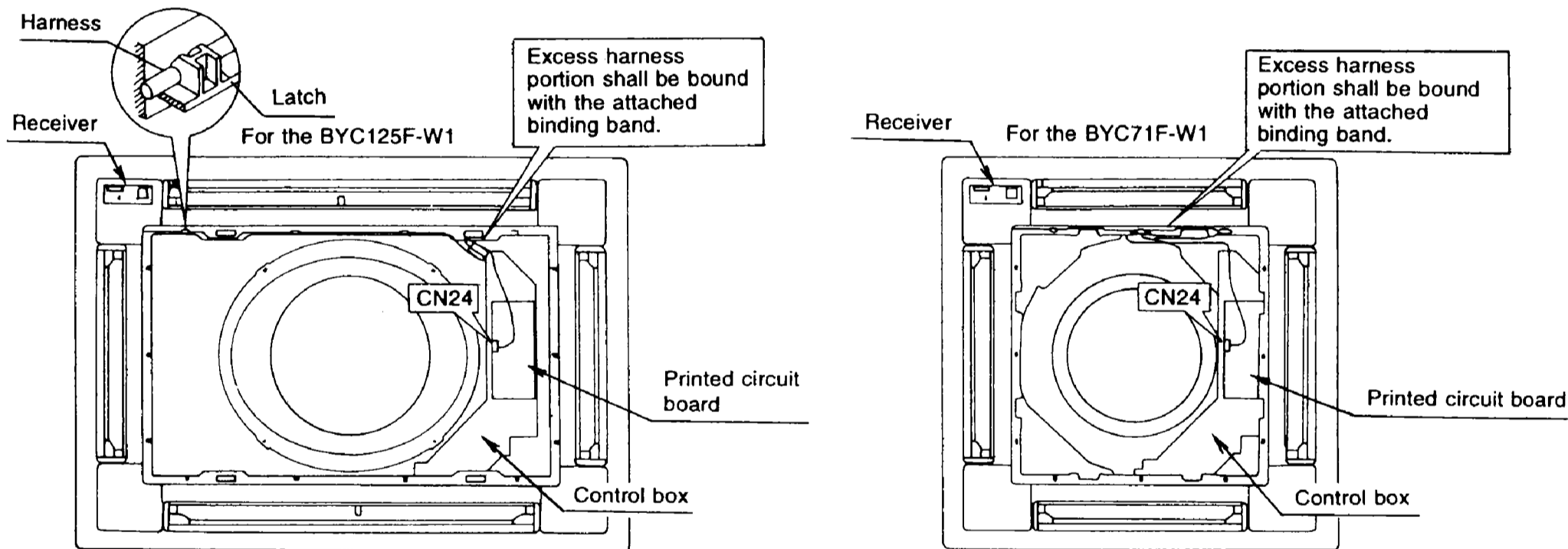
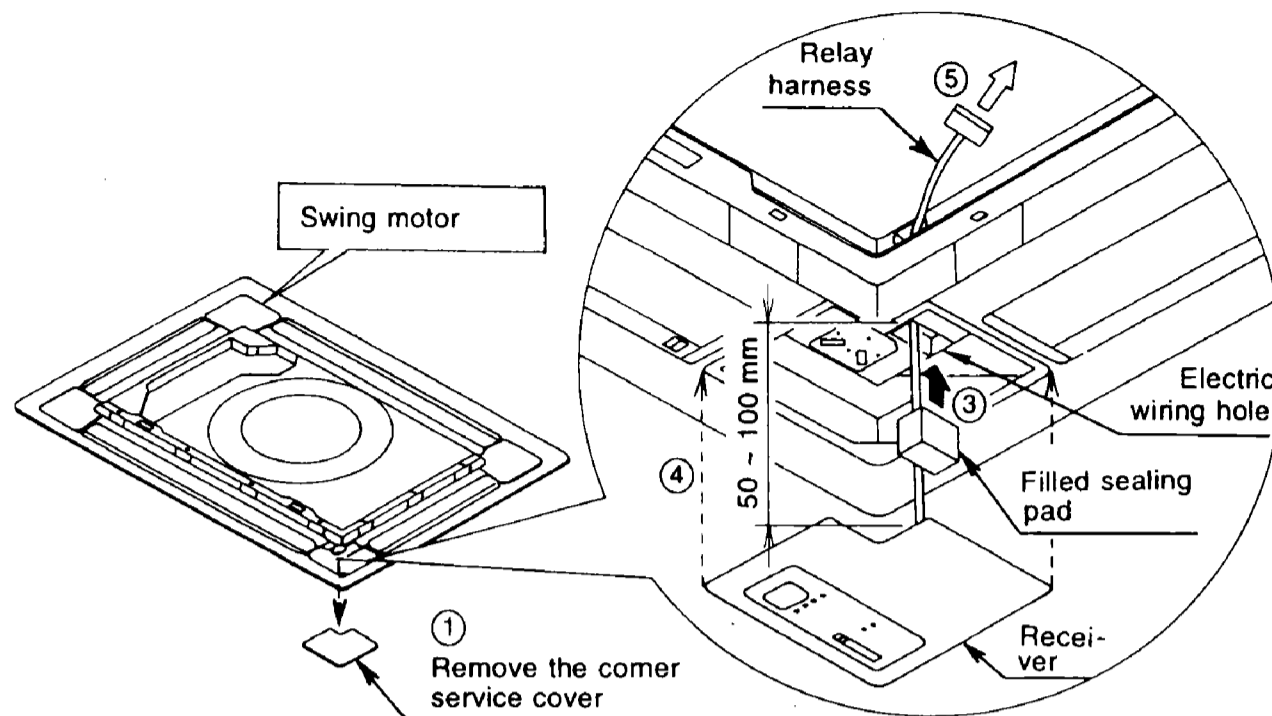
### (3) Installing the receiver

- Remove the corner service cover on the other side of the swing motor. The corner service cover is not needed.

(Refer to the installation manual attached to the decoration panel for attaching and detaching the service cover.)

**The receiver can only be installed at the corner.**

- Remove the sealing pad filled in the hole.
- Pass the relay harness from the receiver through the electric wiring hole until the length of the remaining part is 50 to 100 mm. Now, gently insert the sealing pad into the hole lightly.
- Attach the receiver by following the opposite procedure for removing the former corner service cover.
- Pull the relay harness in the direction of the arrow and prevent the harness from slacking.
- Hang the relay harness from the receiver on the latch of decoration panel latch and connect it to the connector (CN24) on the PC board assembly of the indoor unit. Bind the excess harness portion with the attached binding band.



- Install the cover of the indoor unit control box and the suction grille to the decoration panel.

## FIELD SETTING

(If optional accessories are mounted on the indoor unit, the indoor unit setting may have to be changed. Refer to the instruction manual (optional hand book) for each optional accessory.)

### Procedure

- When in the normal mode, press the "TEST" button for a minimum of four seconds, and the FIELD SET MODE is entered.
- Select the desired MODE NO. with the "MODE" button.
- Push the "▲" button and select the FIRST CODE NO.
- Push the "▲" button and select the SECOND CODE NO.
- Push the "SET" button and the present settings are SET.

⑥ Push the " " button to return to the NORMAL MODE.

(Example) If the time to clean air filter is set to "Filter Contamination-Heavy", set Mode No. to "10", FIRST CODE NO. to "0", and SECOND CODE NO. to "02".

MODE NO.	FIRST CODE NO.	DESCRIPTION OF SETTING	SECOND CODE NO. NOTE)				
			01	02	03		
10	0	Filter Contamination-Heavy/Light (Setting for spacing time of display time to clean air filter) (Setting for when filter contamination is heavy, and spacing time of display time to clean air filter is to be halved)	Light	Approx. 2,500 hrs.	Heavy	Approx. 1,250 hrs.	—
	3	Spacing time of display time to clean air filter count (Setting for when the filter sign is not to be displayed)	Display		Do not display		—
11	0	Setting the number of connected simultaneous operation system indoor units.	Pair		Twin		—
13	0	High ceiling setting (Setting for when installed in a ceiling higher than 2.7 m)	Normal		High Ceiling 1		High Ceiling 2
	1	Selection of Air Flow Direction (Setting for when a blocking pad kit has been installed)	F		T		W
	4	Air Flow Direction Range Setting	Upper		Normal		Lower

NOTE) The SECOND CODE NO. is factory set to "01". However, for the following cases it is set to "02".

- Air Flow Direction Range Setting

Do not use any settings not listed in the table.

For group control with a wireless remote controller, initial settings for all the indoor units of the group are equal. (For group control, refer to the installation manual attached to the indoor unit for group control.)

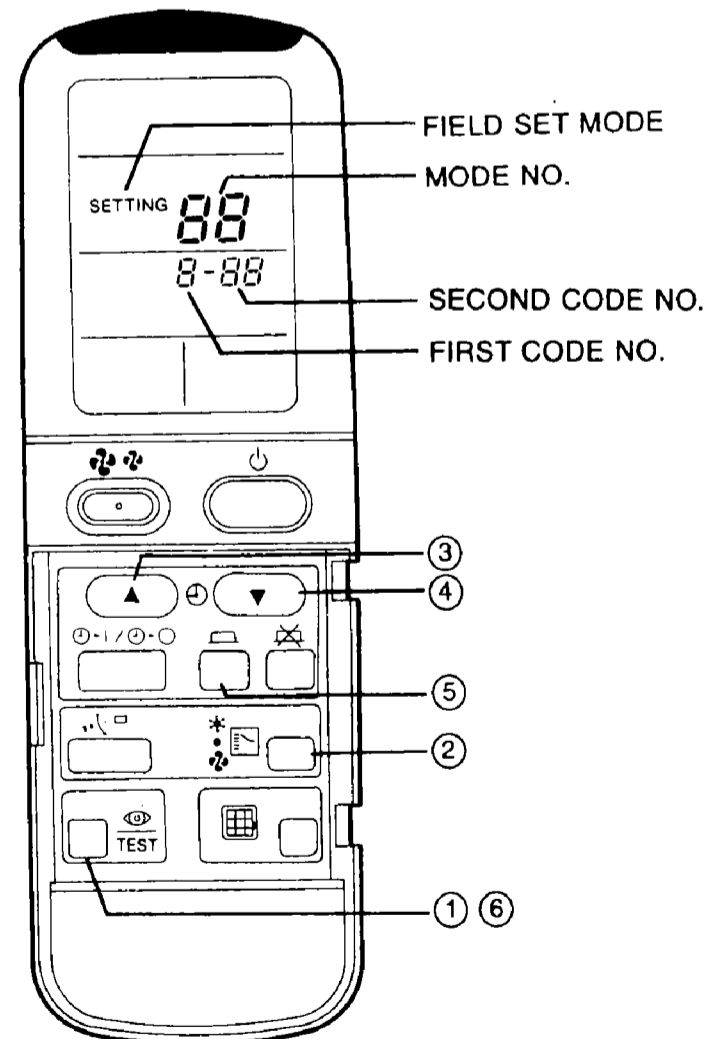
## TEST OPERATION

- Perform test operation according to the instructions in the installation manual attached to the indoor unit.
- After refrigerant piping, drain piping, and electric wiring, operate according to the table to protect the unit.

### < PRECAUTIONS >

1. Refer to malfunction diagnosis label attached to the unit if it does not operate.
2. Refer to the installation manual attached to the outdoor unit for individual operation system types.

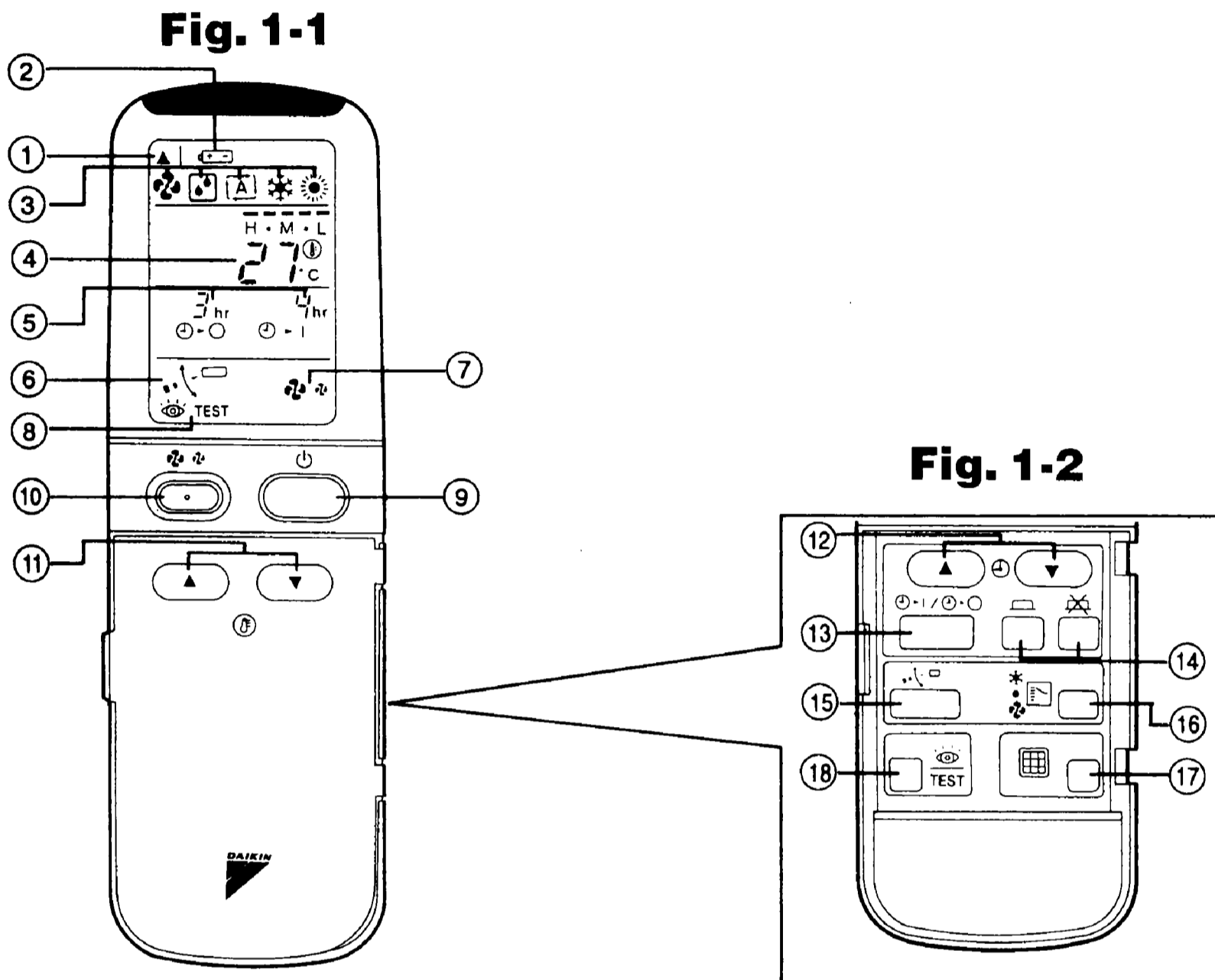
Order	Operation
(1)	Open gas side stop valve.
(2)	Open liquid side stop valve.
(3)	Electrify crank case heater for 6 hours.
(4)	Set to cooling with the remote controller and push ON/OFF button to start operation.
(5)	Push INSPECTION/TEST OPERATION button twice and operate in TEST OPERATION mode for 3 minutes.
(6)	Push AIR FLOW DIRECTION ADJUST button and confirm its operation.
(7)	Push INSPECTION/TEST OPERATION button and operate normally.
(8)	Confirm its function according to the operation manual.



**BRC7A64W** <For FAY-F>.....Heat Pump  
**BRC7A69W** <For FA(Y)-F>.....Cooling only

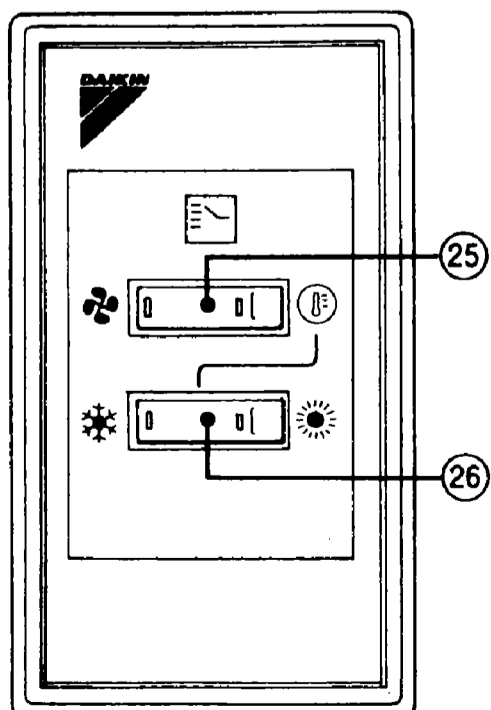
★ Operation

**Fig. 1**

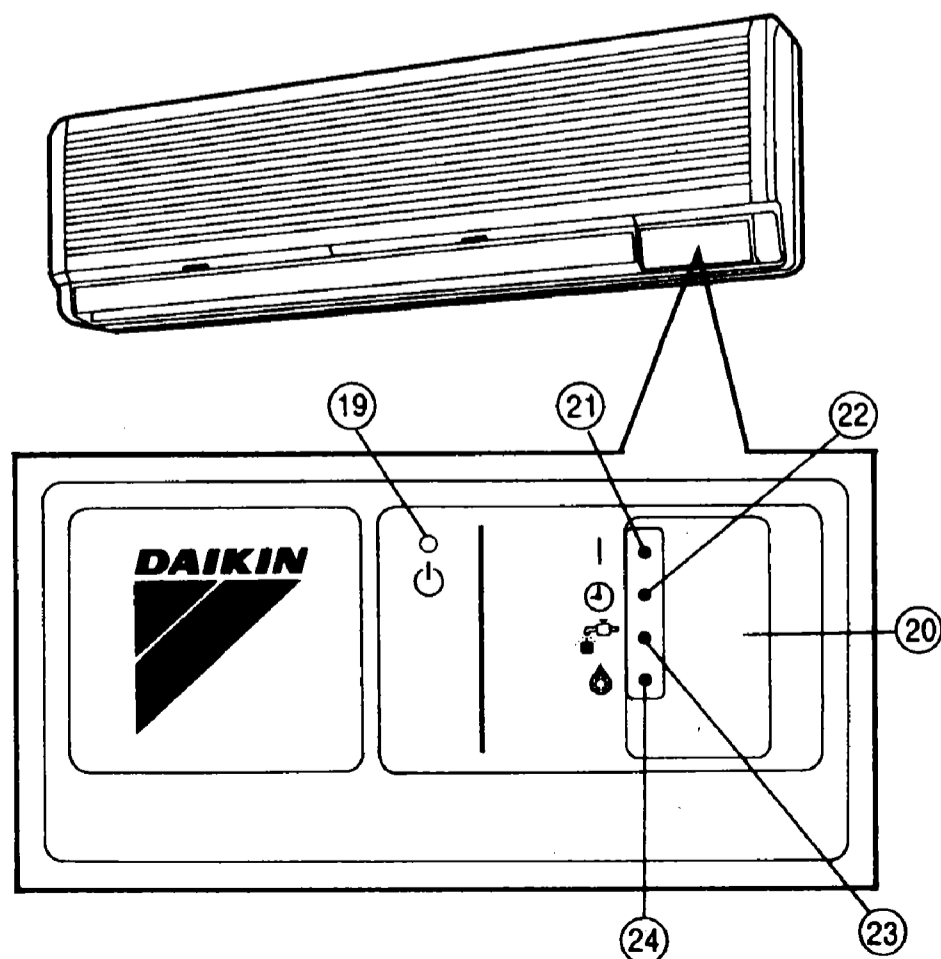


**Fig. 1-3**

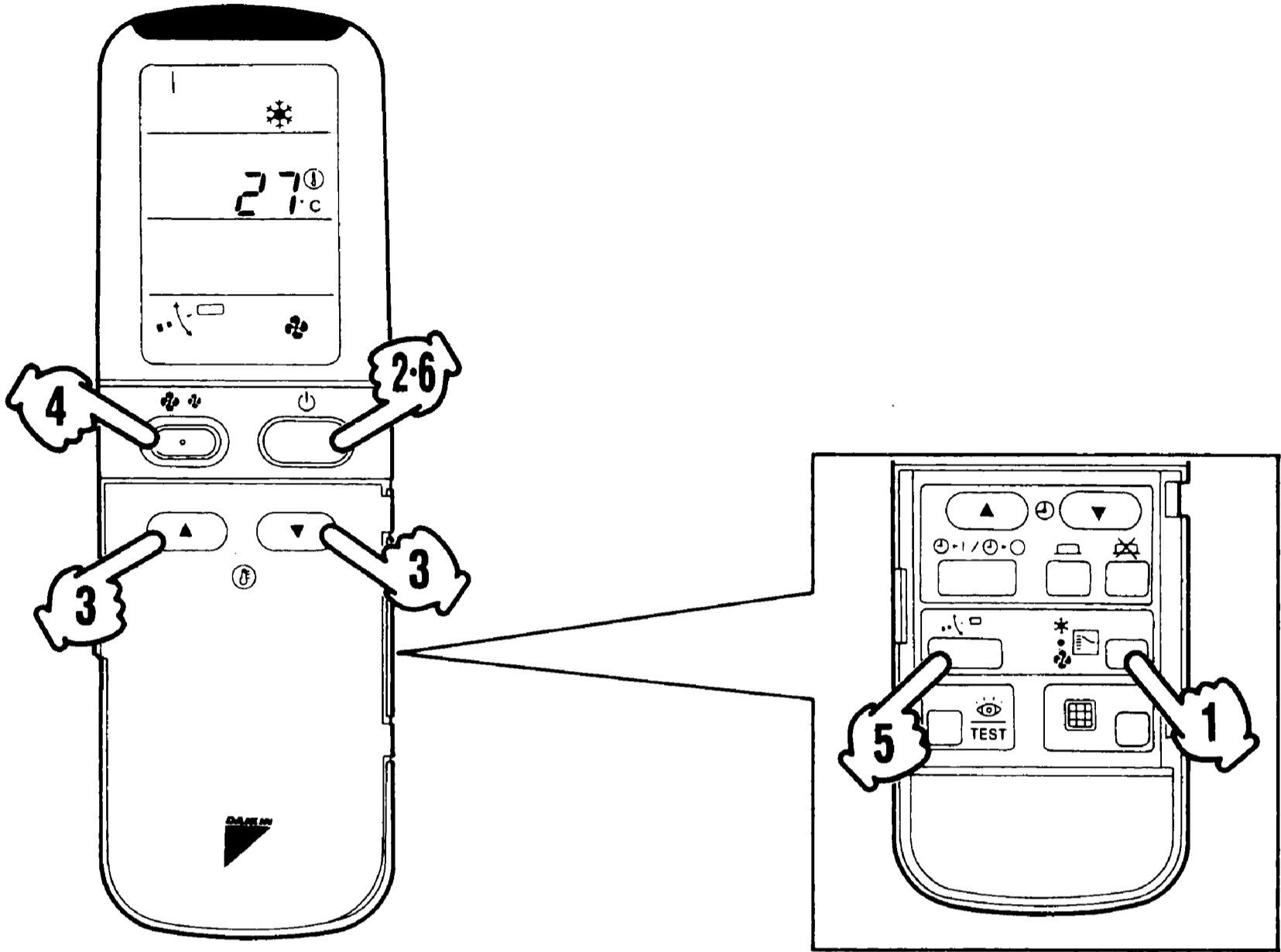
**COOL/HEAT CHANGEOVER  
 REMOTE CONTROL SWITCH**



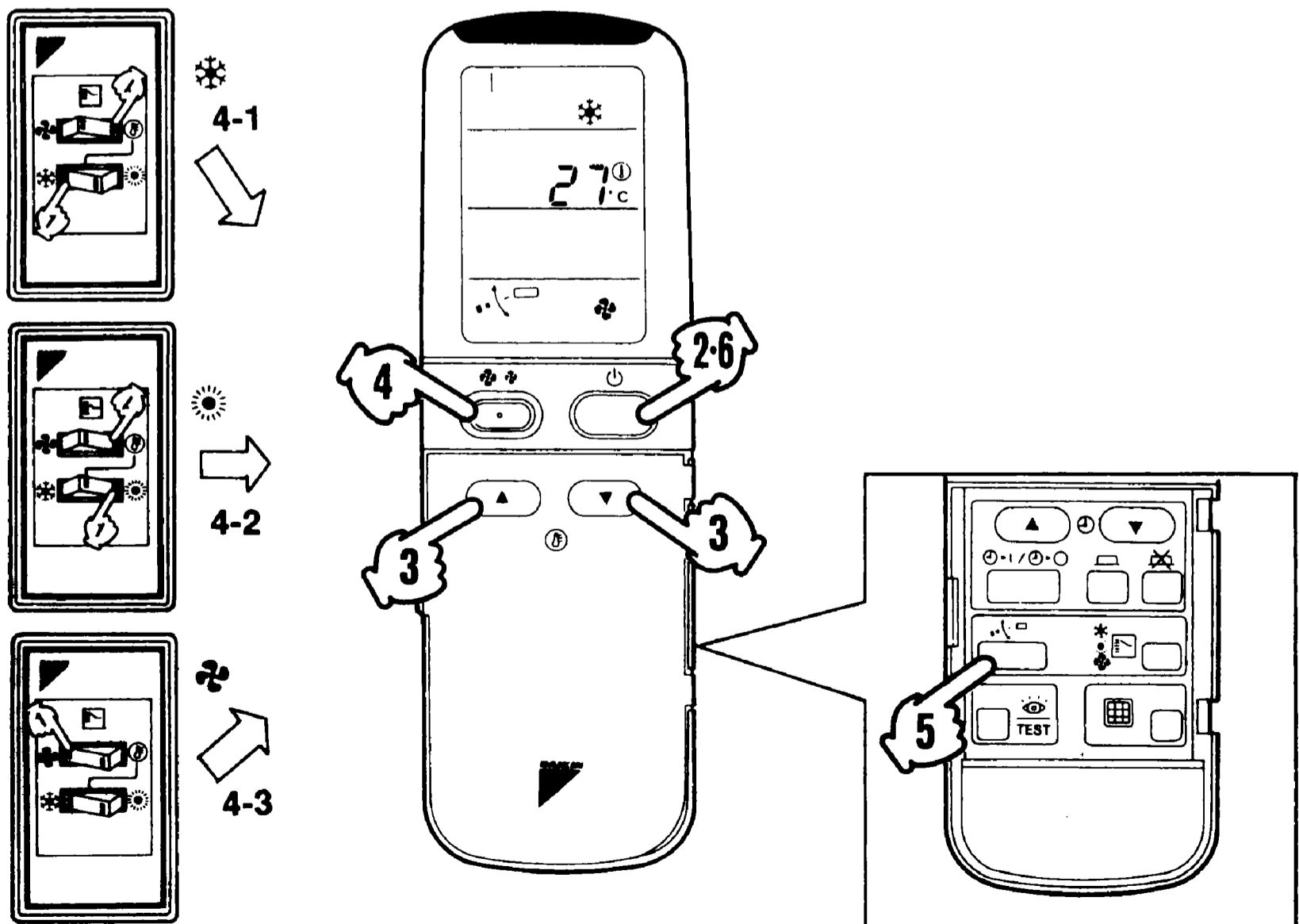
**Fig. 2**



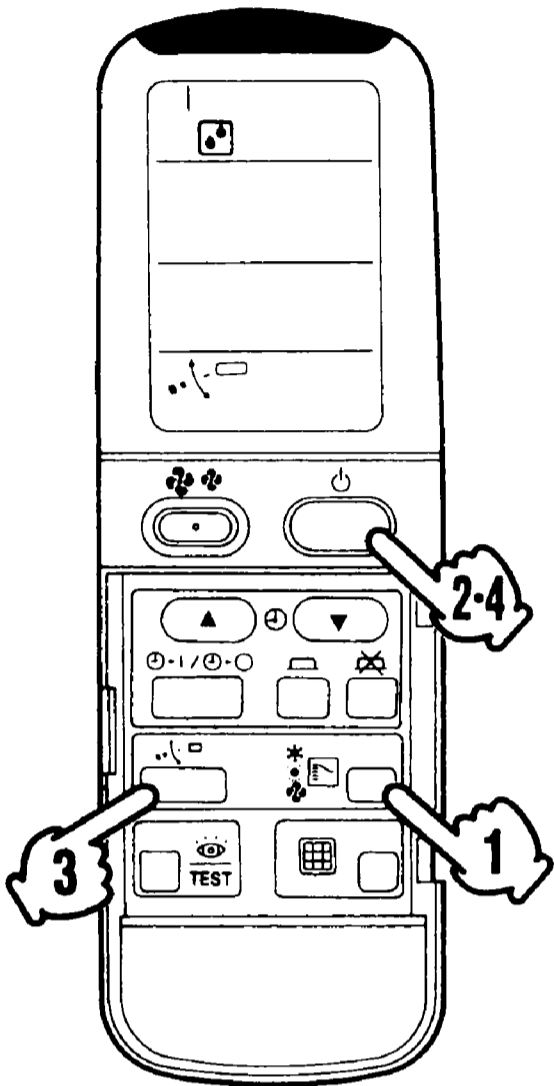
**Fig. 3**



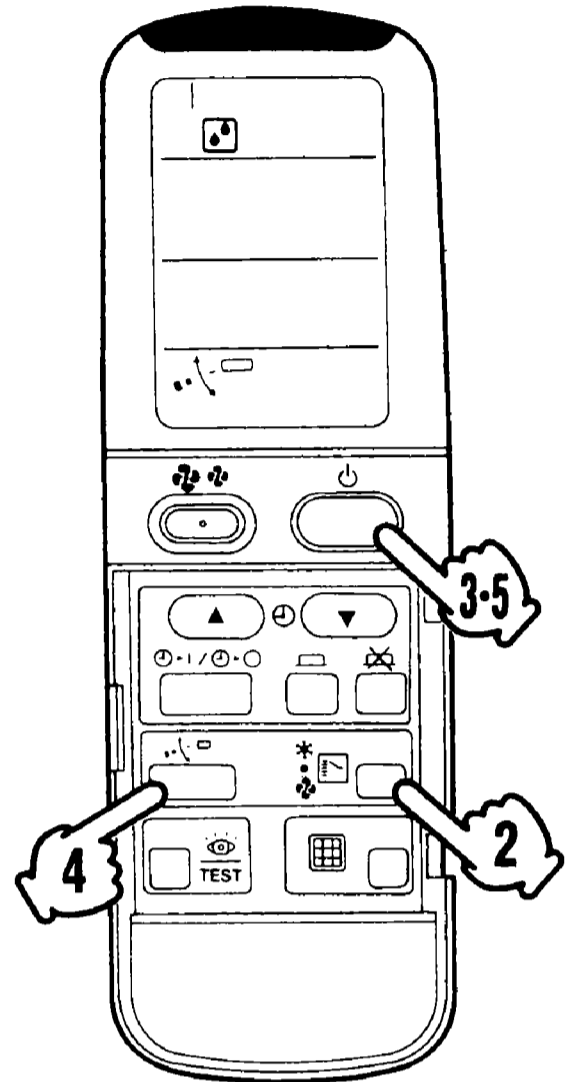
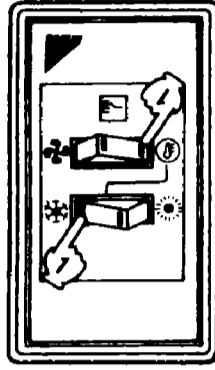
**Fig. 4**



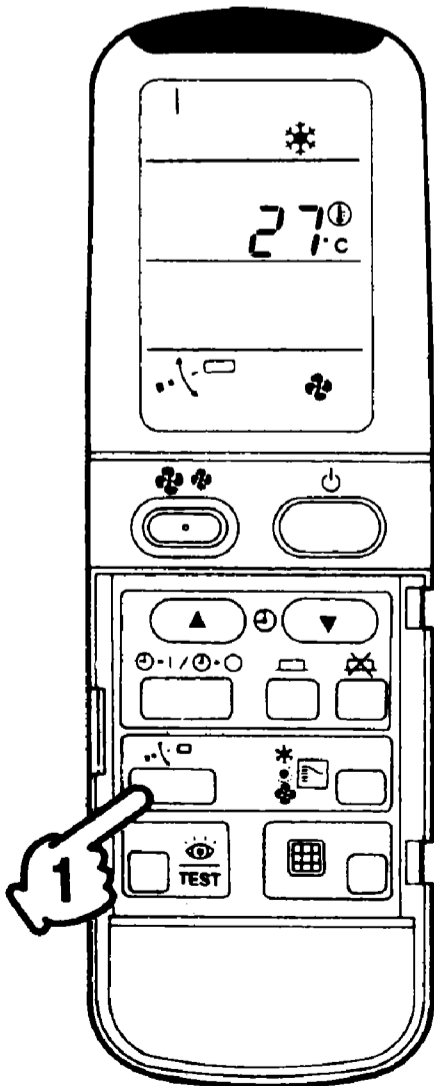
**Fig. 5**



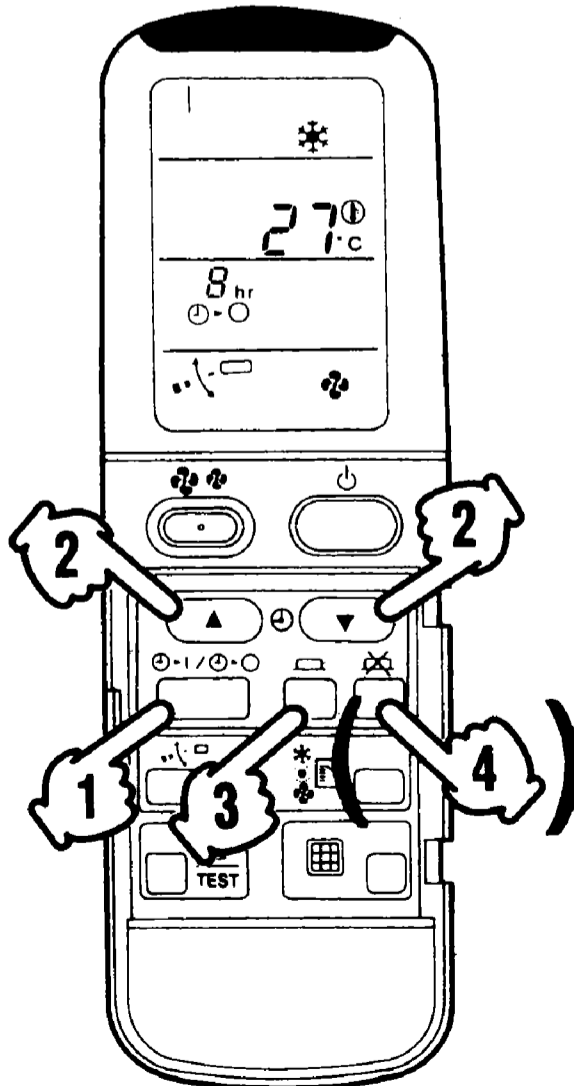
**Fig. 6**



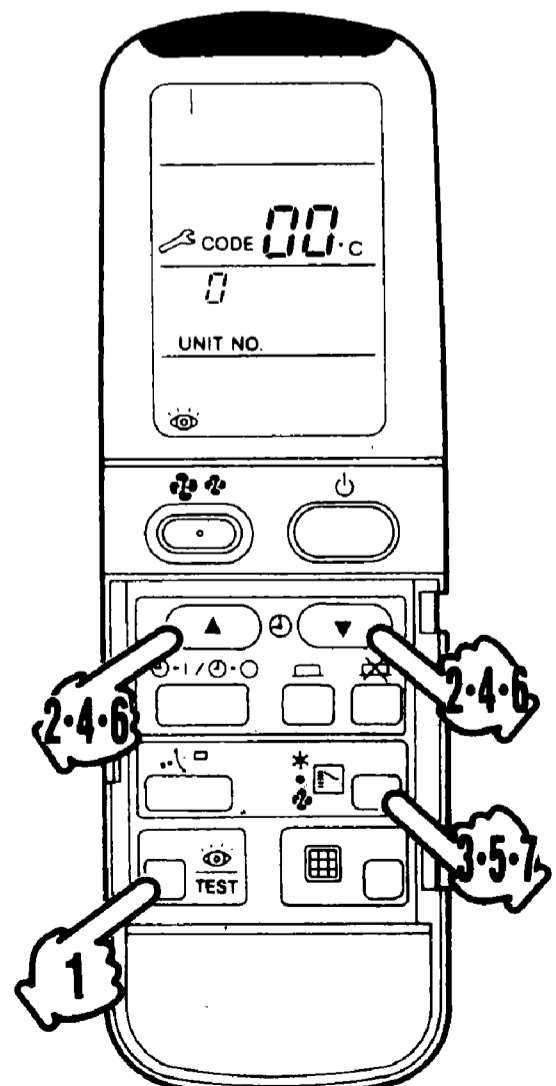
**Fig. 7**





















**Fig. 8**



**Fig. 9**



# NAMES AND FUNCTIONS OF THE OPERATING SECTION (Fig. 1, 2)

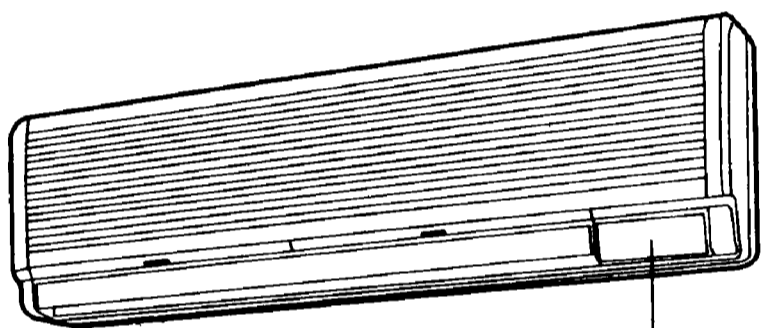
<p>① <b>DISPLAY “▲” (SIGNAL TRANSMISSION)</b> This lights up when a signal is being transmitted.</p>	<p>⑭ <b>TIMER ON/OFF BUTTON</b> Refer to page 54.</p>
<p>② <b>DISPLAY “” (BATTERY REPLACEMENT DISPLAY)</b> If this flashes change the batteries.</p>	<p>⑮ <b>AIR FLOW DIRECTION ADJUST BUTTON</b> Refer to page 54.</p>
<p>③ <b>DISPLAY “” “” “” “” “” (OPERATION MODE)</b> This display shows the current OPERATION MODE. For straight cooling type, “” (Auto) and “” (Heating) are not installed.</p>	<p>⑯ <b>OPERATION MODE SELECTOR BUTTON</b> Press this button to select OPERATION MODE.</p>
<p>④ <b>DISPLAY “H·M·L” (SET TEMPERATURE)</b> 27<sup>°</sup>C This display shows the set temperature.</p>	<p>⑰ <b>FILTER SIGN RESET BUTTON</b> Refer to the section of MAINTENANCE in the operation manual attached to the indoor unit.</p>
<p>⑤ <b>DISPLAY “3 hr 4 hr” (PROGRAMMED TIME)</b>   This display shows PROGRAMMED TIME of the system start or stop.</p>	<p>⑱ <b>INSPECTION/TEST OPERATION BUTTON</b> This button is used only by qualified service persons for maintenance purposes.</p>
<p>⑥ <b>DISPLAY “” (AIR FLOW FLAP)</b> Refer to page 54.</p>	<p>⑲ <b>EMERGENCY OPERATION SWITCH</b> This switch is readily used if the remote controller does not work.</p>
<p>⑦ <b>DISPLAY “” “” (FAN SPEED)</b> The display shows the set fan speed.</p>	<p>⑳ <b>RECEIVER</b> This receives the signals from the remote controller.</p>
<p>⑧ <b>DISPLAY “ TEST” (INSPECTION/TEST OPERATION)</b> When the INSPECTION/TEST OPERATION BUTTON is pressed, the display shows the system mode is in.</p>	<p>㉑ <b>OPERATING INDICATOR LAMP (Red)</b> This lamp stays lit while the air conditioner runs. It flashes when the unit is in trouble.</p>
<p>⑨ <b>ON/OFF BUTTON</b> Press the button and the system will start. Press the button again and the system will stop.</p>	<p>㉒ <b>TIMER INDICATOR LAMP (Green)</b> This lamp stays lit while the timer is set.</p>
<p>⑩ <b>FAN SPEED CONTROL BUTTON</b> Press this button to select the fan speed, HIGH or LOW, of your choice.</p>	<p>㉓ <b>AIR FILTER CLEANING TIME INDICATOR LAMP (Red)</b> Lights up when it is time to clean the air filter.</p>
<p>⑪ <b>TEMPERATURE SETTING BUTTON</b> Use this button for SETTING TEMPERATURE (Operates with the front cover of the remote controller closed.)</p>	<p>㉔ <b>DEFROST LAMP (Orange)</b> Lights up when the defrosting operation has started. (For straight cooling type this lamp does not turn on.)</p>
<p>⑫ <b>PROGRAMMING TIME BUTTON</b> Use this button for programming “START and/or STOP” time. (Operates with the front cover of the remote controller opened.)</p>	<p>㉕ <b>FAN/AIR CONDITIONING SELECTOR SWITCH</b> Set the switch to “” (FAN) for FAN and “” (A/C) for HEAT or COOL.</p>
<p>⑬ <b>TIMER MODE START/STOP BUTTON</b> Refer to page 54.</p>	<p>㉖ <b>COOL/HEAT CHANGEVER SWITCH</b> Set the switch to “” (COOL) for COOL and “” (HEAT) for HEAT.</p> <p>(NOTE)</p> <ul style="list-style-type: none"> <li>• For the sake of explanation, all indications are shown on the display in Figure 1 contrary to actual running situations.</li> <li>• Fig. 1-2 shows the remote controller with the front cover opened.</li> <li>• Fig. 1-3 shows this remote controller can be used in conjunction with the one provided with the VRV system.</li> <li>• If the air filter cleaning time indicator lamp lights up, clean the air filter as explained in the operation manual provided with the indoor unit. After cleaning and reinstalling the air filter, press the filter sign reset button on the remote controller. The air filter cleaning time indicator lamp on the receiver will go out.</li> </ul>

# HANDLING FOR WIRELESS REMOTE CONTROLLER

## Precautions in handling remote controller

Direct the transmitting part of the remote controller to the receiving part of the air conditioner.

If something blocks the transmitting and receiving path of the indoor unit and the remote controller as curtains, it will not operate.



Receiver



2 short beeps from the receiver indicates that the transmission is properly done.

Transmitting distance is approximately 12 m.

Do not drop or get it wet.

It may be damaged.

Never press the button of the remote controller with a hard, pointed object.

The remote controller may be damaged.

## Installation site

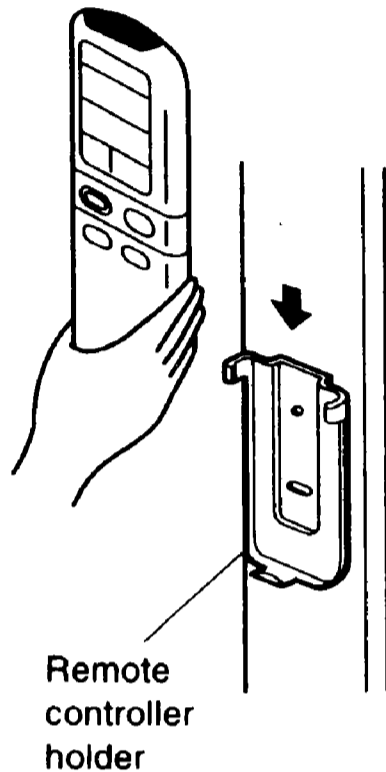
- It is possible that signals will not be received in rooms that have electronic fluorescent lighting. Please consult with the salesman before buying new fluorescent lights.
- If the remote controller operated some other electrical apparatus, move that machine away or consult your dealer.

## Placing the remote controller in the remote controller holder

Install the remote controller holder to a wall or a pillar with the attached screw. (Make sure it transmits)

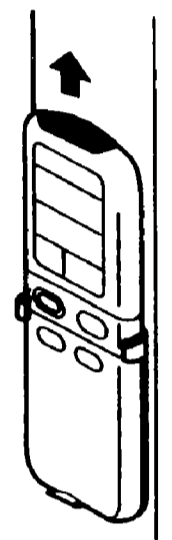
### Placing the remote controller

Slide from above



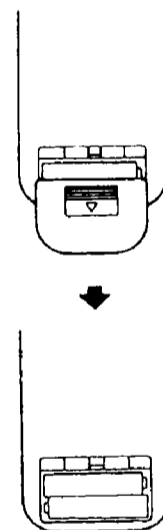
### Removing the remote controller

Pull it upward



## How to put the dry batteries

- ① Remove the back cover of the remote controller to the direction pointed by the arrow mark.
- ② Pull in batteries  
Use two LRO3<IEC> dry cell batteries. Pull dry batteries correctly to fit their (+) and (-).
- ③ Close the cover



## CAUTIONS

- Replace all batteries at the same time, do not use new and old batteries intermixed.
- In case the remote controller is not used for a long time, remove all batteries in order to prevent liquid leak of the battery.
- Under normal use the batteries should last for 1 year.

## IN THE CASE OF CENTRALIZED CONTROL SYSTEM

- If the indoor unit is under centralized control, it is necessary to switch the remote controller's setting switch (A, B) to "B". In this case, refer to "PRECAUTIONS AT CENTRALIZED CONTROL" (p. 56). (Contact your DAIKIN dealer to find out whether your system is a centralized control type.)



# OPERATION PROCEDURE





- Operating procedure varies with heat pump type and straight cooling type. Contact your Daikin dealer to confirm your system type.
- To protect the unit, turn on the main power switch 6 hours before operation.
- If the main power supply is turned off during operation, operation will restart automatically after the power turns back on again.

## COOLING, HEATING, AUTOMATIC AND FAN OPERATION (Fig. 3, 4)

- AUTOMATIC OPERATION can be selected only by RSEY series.
- RSX series gives selection of FAN or COOLING OPERATION only.

■ **FOR SYSTEMS WITHOUT COOL/HEAT CHANGEOVER REMOTE CONTROL SWITCH (Fig. 3)**

**1** Press OPERATION MODE SELECTOR button several times and select the OPERATION MODE of your choice as follows.

- COOLING OPERATION ..... "  "
- HEATING OPERATION ..... "  "
- AUTOMATIC OPERATION ..... "  "
- FAN OPERATION ..... "  "

### On AUTOMATIC OPERATION






In this operation mode, COOL/HEAT changeover is automatically conducted at a present indoor temperature.

**2** Press ON/OFF button

OPERATION lamp lights up and the system starts OPERATION.

■ **FOR SYSTEMS WITH COOL/HEAT CHANGEOVER REMOTE CONTROL SWITCH (Fig. 4)**

**1** Select OPERATION MODE with the COOL/HEAT CHANGEOVER REMOTE CONTROL SWITCH as follows.

- COOLING OPERATION.....Refer to fig. 4-1  
(  ,  )
- HEATING OPERATION.....Refer to fig. 4-2  
(  ,  )
- FAN OPERATION.....Refer to fig. 4-3 (  )



**2** Press ON/OFF button

OPERATION lamp lights up and the system starts OPERATION.



### Adjustment

For programming TEMPERATURE and FAN SPEED and AIR FLOW DIRECTION, follow the procedure shown below.

**3** Press TEMPERATURE SETTING button and program the setting temperature.

-  Each time this button is pressed, setting temperature rises 1°C.
-  Each time this button is pressed, setting temperature lowers 1°C.

### In case of automatic operation

-  Each time this button is pressed, setting temperature shifts to "H" side.
-  Each time this button is pressed, setting temperature shifts to "L" side.

[°C]

	H	•	M	•	L
Setting temperature	25	23	22	21	19

Note:

- The setting is impossible for fan operation.

**4** Press **FAN SPEED CONTROL** button.

High or Low fan speed can be selected.

**5** Press **AIR FLOW DIRECTION** button

Refer to "ADJUSTING THE AIR FLOW DIRECTION" (p. 54) for details.

**STOPPING THE SYSTEM**

**6** Press **ON/OFF** button once again.

OPERATION lamp goes off, and the system stops OPERATION.

Note:

- Do not turn OFF power immediately after the unit stops. Then, wait no less than 5 minutes. Water is leaking or there is something else wrong with the unit.

## **EXPLANATION OF HEATING OPERATION**


### **DEFROST OPERATION**

- As the frost on the coil of an outdoor unit increase, heating effect decreases and the system goes into DEFROST OPERATION.
- The fan operation stops and the DEFROST lamp of the indoor unit goes on.  
After 6 to 8 minutes (maximum 10 minutes) of DEFROST OPERATION, the system returns to HEATING OPERATION.

## **PROGRAM DRY OPERATION (Fig. 5, 6)**

- The function of this program is to decrease the humidity in your room with the minimum temperature decrease.
- Micro computer automatically determines TEMPERATURE and FAN SPEED.
- This system does not go into operation if the room temperature is below 16°C.

■ **FOR SYSTEMS WITHOUT COOL/HEAT CHANGEOVER REMOTE CONTROL SWITCH (Fig. 5)**

**1** Press **OPERATION MODE SELECTOR** button several times and select "  " (**PROGRAM DRY OPERATION**)

**2** Press **ON/OFF** button

OPERATION lamp lights up and system starts OPERATION.

**Adjustment**

**3** Press **AIR FLOW DIRECTION ADJUST** button.

Refer to "ADJUSTING THE AIR FLOW DIRECTION" (p. 54) for details.

**STOPPING THE SYSTEM**

**4** Press **ON/OFF** button again.

OPERATION lamp goes off, and the system stops OPERATION.

Note:

- Do not turn OFF power immediately after the unit stops. Then, wait no less than 5 minutes. Water is leaking or there is something else wrong with the unit.

■ **FOR SYSTEMS WITH COOL/HEAT CHANGEOVER REMOTE CONTROL SWITCH (Fig. 6)**

**1** Select **COOLING OPERATION MODE** with the **COOL/HEAT CHANGEOVER REMOTE CONTROL SWITCH**.

**2** Press **OPERATION MODE SELECTOR** button several times and select **PROGRAM DRY** "  ".

### 3 Press ON/OFF button.

OPERATION lamp lights up and the system starts.

### 4 Press AIR FLOW DIRECTION ADJUST button.

Refer to "ADJUSTING THE AIR FLOW DIRECTION" (p. 54) for details.

## STOPPING THE SYSTEM

### 5 Press ON/OFF button once again.

OPERATION lamp goes off, and the system stops OPERATION.


Note:

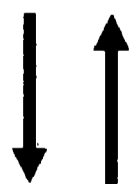
- Do not turn OFF power immediately after the unit stops. Then, wait no less than 5 minutes. Water is leaking or there is something else wrong with the unit.

## ADJUSTING THE AIR FLOW DIRECTION (Fig. 7)


Press the AIR FLOW DIRECTION ADJUST button to adjust up/down air flow angle.

### 1 Press the AIR FLOW DIRECTION ADJUST button to select the air direction as shown below.

" " DISPLAY appears and the air flow direction continuously varies. (Automatic swing setting)



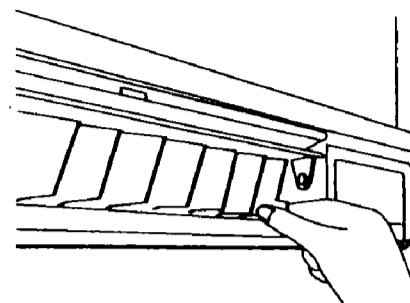
Press AIR FLOW DIRECTION ADJUST button to select the air direction of your choice.

" " DISPLAY vanishes and the desired air flow direction is fixed. (Fixed air flow setting)

- If you try cooling or programmed drying, while the flaps are facing downward, air flow direction may change unexpectedly. There is nothing wrong with the equipment. This serves to prevent dew formed on parts in the air discharge outlet from dripping.

## Adjusting left/right air flow direction




Angle the flaps to the left/right from the knob, as wanted or as needed to air condition the room.



NOTE:

- Stop flaps from swinging before trying to angle them. Working while the flaps are moving may get your fingers pinched.

## PROGRAM TIMER OPERATION (Fig. 8)

- The timer is operated by the following two ways. Programming the stop time (  >  ). . . . The system stops operating after the time setting has elapsed. Programming the start time (  > | ). . . . The system starts operating after the time setting has elapsed.
- The timer can be programmed for a maximum of 72 hours.
- The start and the stop time can simultaneously be programmed.

### 1 Press the TIMER MODE START/STOP button several times and select the mode on the display.

The display flashes.

For setting the timer stop . . . . . (  >  )

For setting the timer start . . . . . (  > | )

### 2 Press the PROGRAMMING TIME button and set the time for stopping or starting the system.



When this button is pressed, the time advances by 1 hour.



When this button is pressed, the time goes backward by 1 hour.

### 3 Press TIMER ON button.

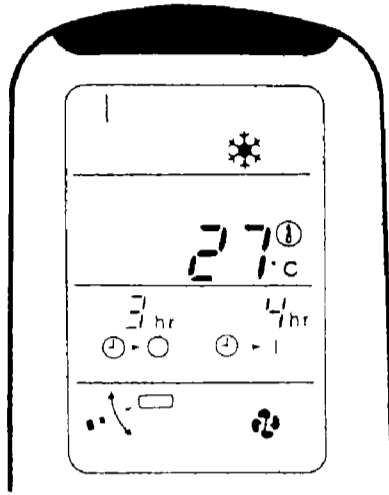
The timer setting procedure ends.

The display or changes from flashing light to a constant light.

**NOTE**

- When setting the timer Off and On at the same time, repeat the above procedure from ① to ③ once again.

For example.



When the timer is programmed to stop the system after 3 hours and start the system after 4 hours, the system will stop after 3 hours and then 1 hour later the system will start.

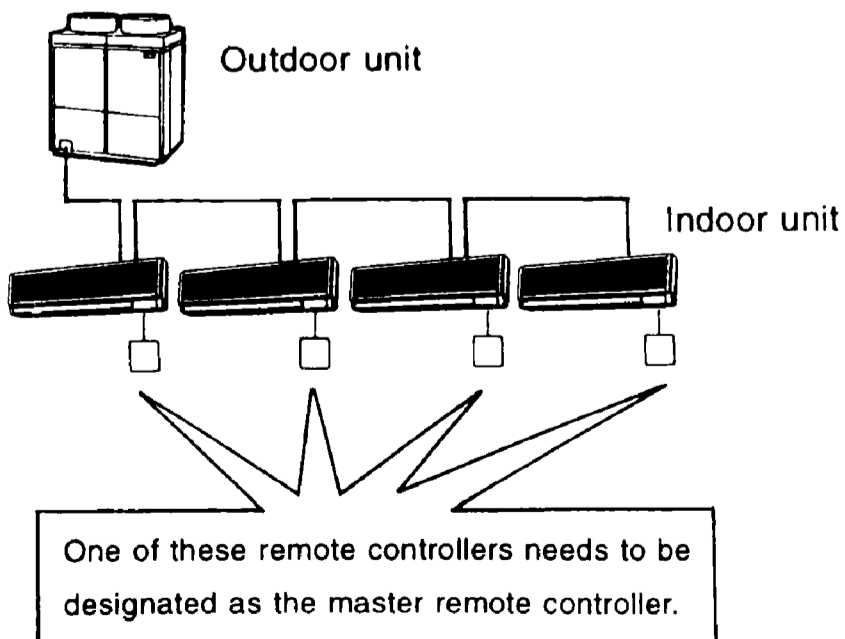
- After the timer is programmed, the display shows the remaining time.
- Press the TIMER OFF button to cancel programming. The display vanishes. (④)

## HOW TO SET MASTER REMOTE CONTROLLER (For RSXY and RSEY series)

- When the system is installed as shown below, it is necessary to designate the master remote controller.

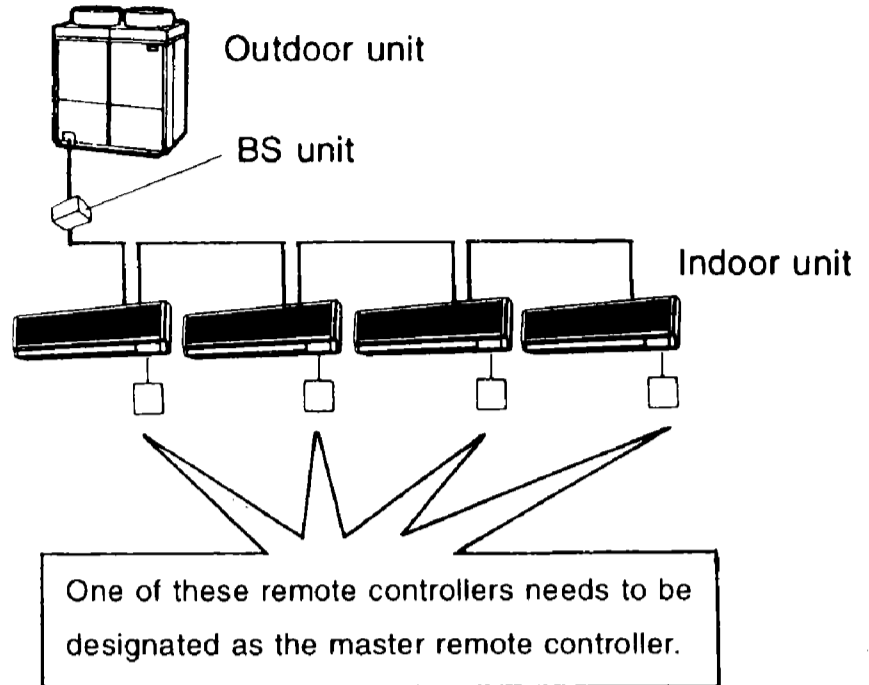
### ■ For RSXY series

When one outdoor unit is connected with several indoor units.



### ■ For RSEY series

When one BS unit is connected with several indoor units.



- Only the master remote controller can select HEATING, COOLING or AUTOMATIC (only RSEY series) OPERATION.

When the indoor unit with master remote controller is set to "COOL", you can switch over operation mode between "FAN", "DRY" and "COOL".

When the indoor unit with master remote controller is set to "HEAT", you can switch over operation mode between "FAN" and "HEAT".

When the indoor unit with master remote controller is set to "FAN", you cannot switch operation mode.

When attempting settings than that consented above, a "peep" is emitted as a warning.

Only with RSEY series, you can set the indoor unit to AUTOMATIC. Attempting to do so, a "peep" will be emitted as a warning.

### How to designate the master remote controller

- ① Continuously press the OPERATION MODE SELECTOR button for 4 seconds.

The displays showing "Ⓜ" of all slave indoor unit connected to the same outdoor unit or BS unit flash.

**2** Press the **OPERATION MODE SELECTOR** button to the indoor unit that you wish to designate as the master remote controller. Then designation is completed. This indoor unit is designated as the master remote controller and the display showing “**Ⓜ**” vanishes.

- To change settings, repeat steps **1** and **2**

## EMERGENCY OPERATION

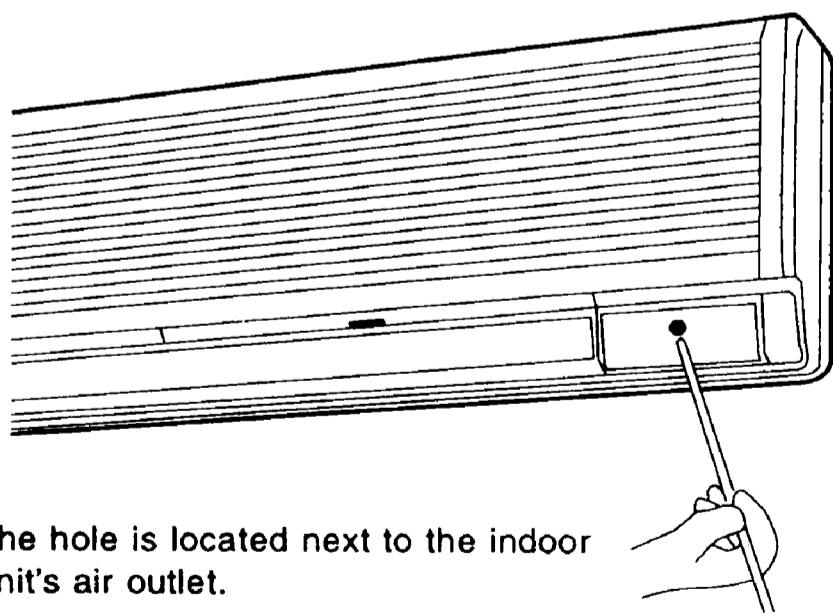
When the remote controller does not work due to battery failure or the absence thereof, use this switch which is located beside the discharge grille on the main unit. When the remote controller does not work, but the battery low indicator on it is not lit, contact your dealer.

### START

**1** To press the emergency operation switch, insert a match stick or other object narrow enough to fit inside the hole.

The machine runs in the previous mode.

The system operates with the previously set air flow direction.



The hole is located next to the indoor unit's air outlet.

### STOP

**2** Press the **EMERGENCY OPERATION** switch again.

## PRECAUTIONS FOR GROUP CONTROL SYSTEM OR TWO REMOTE CONTROLLER CONTROL SYSTEM

This system provides two other control systems beside individual control (one remote controller controls one indoor unit) system. Confirm the following if your unit is of the following control system type.

### ■ Group control system

One remote controller controls up to 16 indoor units.

All indoor units are equally set.

### ■ Two remote controller control system

Two remote controllers control one indoor unit. (In case of group control system, one group of indoor units)

The unit follows individual operation.

### NOTE:

- Cannot have two remote controller control system with only wireless remote controllers. (It will be a two remote controller control system having one wired and one wireless remote controllers.)
- Under two remote controller control system, wireless remote controller cannot control timer operation.
- Only the operating indicator lamp out of 3 other lamps on the indoor unit display functions.

### NOTE:

Contact your Daikin dealer in case of changing the combination or setting of group control and two remote controller controls systems.

## PRECAUTIONS AT CENTRALIZED CONTROL

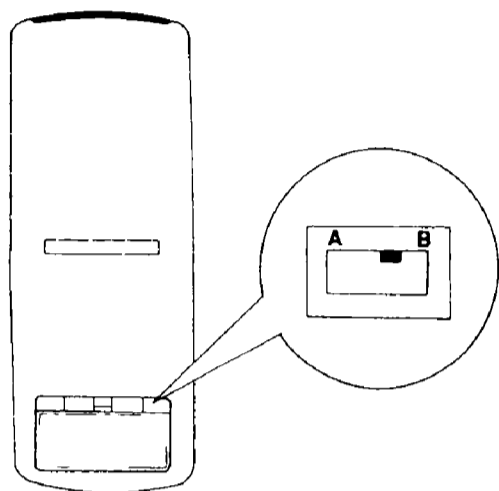
- If the indoor unit is under centralized control, the operation using the remote controller becomes limited and controls fewer functions.
- The display of the remote controller indicates only the changed setting and it will vanish after few seconds.

<< If the above-mentioned operation is not carried out, switch the remote controller's setting switch to "B." >>  
(Setting Method)

Switch the setting switch to "B."

Operation may not be accepted if the switch remains set to "A" (factory set).

Return the switch to "A" if you want to change to individual control (standard control).



■ **In case the setting which is under centralized control is chosen:**

The RECEIVER of the indoor unit makes three short beeps meaning the operation is not accepted.

■ **If the operation allowing use of remote controllers is chosen:**

The RECEIVER of the indoor unit makes two short beeps meaning the operation is accepted.

## NOT MALFUNCTION OF THE AIR CONDITIONER

### The following symptoms do not indicate air conditioner malfunction

#### I. THE SYSTEM DOES NOT OPERATE

- **The system does not restart immediately after the ON/OFF button is pressed.**

If the OPERATION lamp lights, the system is in normal condition. It does not restart immediately because a safety device operates to prevent overload of the system. After 3 minutes, the system will turn on again automatically.

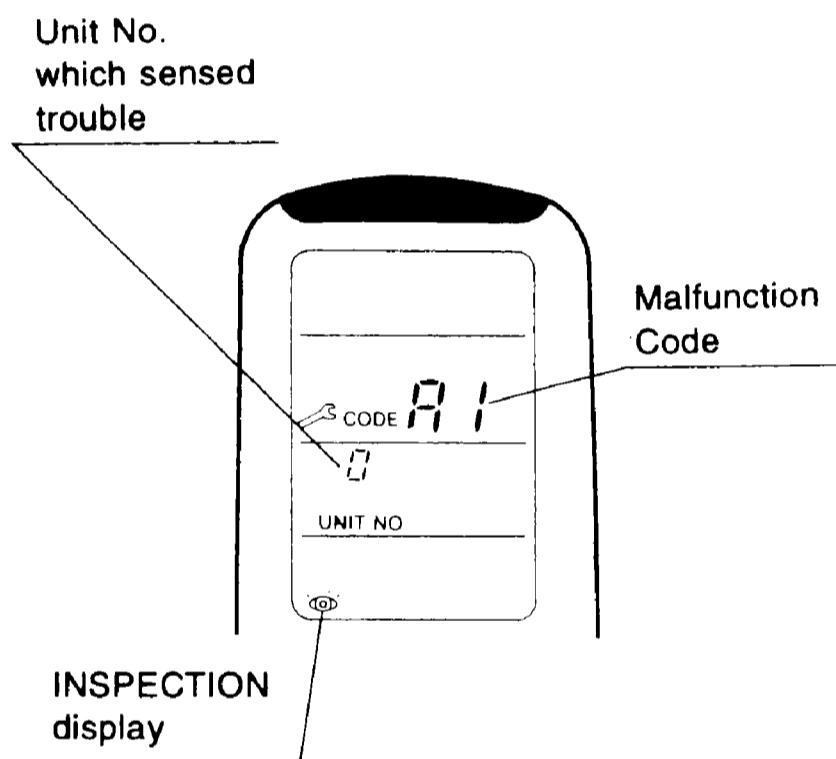
- **The system does not restart immediately when TEMPERATURE SETTING button is returned to the former position after pushing the button.**

It does not restart immediately because a safety device operates to prevent overload of the system. After 3 minutes, the system will turn on again automatically.

# HOW TO DIAGNOSE TROUBLE SPOTS (Fig. 9)

## I. EMERGENCY STOP

When the air conditioner stops in emergency, the run lamp on the indoor unit starts blinking. Take the following steps yourself to read the malfunction code that appears on the display. Contact your dealer with this code. It will help pinpoint the cause of the trouble, speeding up the repair.



**1** Press the **INSPECTION/TEST** button to select the inspection mode "0".

"0" appears on display and blinks. "UNIT" lights up.

**2** Press **PROGRAMMING TIMER** **BUTTON** and change the unit number.

Press to change the unit number until the indoor unit beeps and perform the following operation according to the number of beeps.

### Number of beeps

3 short beeps . . . . . Perform all steps from **3** to **6**

1 short beep . . . . . Perform **3** and **6** steps

1 long beep . . . . . Normal state

**3** Press **OPERATION MODE** **SELECTOR** **BUTTON**

"0" on the left-hand of the malfunction code blinks.

**4** Press **PROGRAMMING** **TIMER** **BUTTON** and change the malfunction code.

Press until the indoor unit beeps twice.

**5** Press **OPERATION** **MODE** **SELECTOR** **BUTTON**

"0" on the right-hand of the malfunction code blinks.

**6** Press **PROGRAMMING** **TIMER** **BUTTON** and change the malfunction code.

Press until the indoor unit makes a long beep. The malfunction code is fixed when the indoor unit makes a long beep.

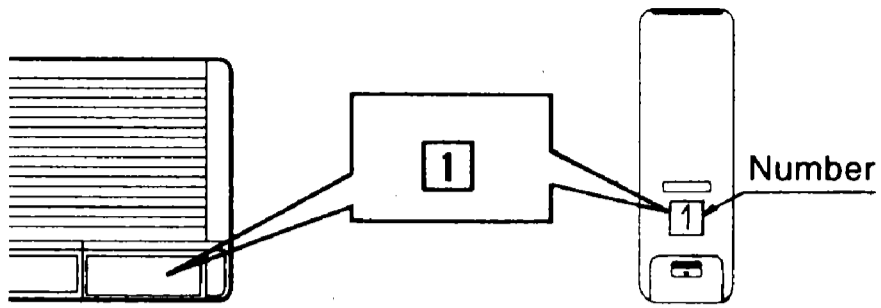
**7** **Reset of the display**

Press **OPERATION** **MODE** **SELECTOR** **BUTTON** to get the display back to the normal state.

## II. IN CASE BESIDES EMERGENCY STOP

### 1. The unit does not operate at all.

- Check if the receiver is exposed of sunlight or strong light. Keep receiver away from light.
- Check if there are batteries in the remote controller. Place the batteries.
- Check if the indoor unit number and wireless remote controller number are equal.



Operate the indoor unit with the remote controller of the same number.

Signal transmitted from a remote controller of a different number cannot be accepted. (If the number is not mentioned, it is considered as "1")

**2. The system operates but it does not sufficiently cool or heat.**

- If the set temperature is not proper.
- If the FAN SPEED is set to LOW SPEED.
- If the air flow angle is not proper.



★ Installation

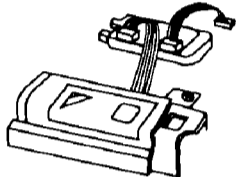

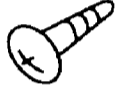

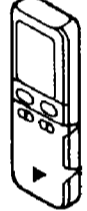
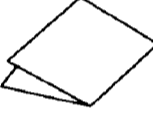
# BEFORE INSTALLATION

## PRECAUTIONS

- Refer to the installation manual attached to the indoor unit.
- Confirm that following conditions are satisfied prior to installation.
  - Ensure that nothing interrupts the operation of the wireless remote controller. (Ensure that there is neither a source of light nor fluorescent lamp near the receiver. Also, ensure that the receiver is not exposed of direct sun light.)
  - Ensure that the operation display lamp and other indicators are easy to see.

## ACCESSORIES

Check if the following accessories are included with your unit.

Name	Shape	Quantity	Name	Shape	Quantity	Name	Shape	Quantity									
Wireless display cover		1 set	Remote controller holder		1 pc.	Screw for installing remote controller holder		2 pcs.									
			Dry cell battery LR03 (AM4)		2 pcs.												
Wireless remote controller		1 pc.	Unit No. label	<table border="1" data-bbox="898 1270 1081 1405"> <tr><td>1</td><td>2</td><td>3</td></tr> <tr><td>1</td><td>2</td><td>3</td></tr> <tr><td>1</td><td>2</td><td>3</td></tr> </table>	1	2	3	1	2	3	1	2	3	1 pc.	Operation manual		1 pc.
			1	2	3												
1	2	3															
1	2	3															

## NOTE TO THE INSTALLER

Be sure to instruct the customer how to properly operate the system showing him/her the attached operation manual.

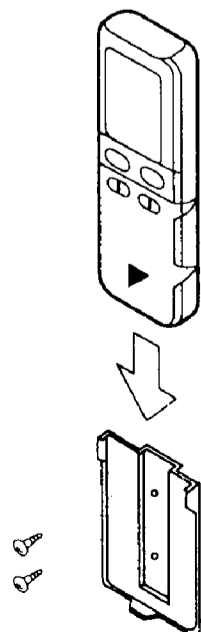
# REMOTE CONTROLLER INSTALLATION

## < Installing wireless remote controller >

- Do not throw the remote controller or impose large shocks. Also, do not store where it may be exposed to moisture or direct sunlight.
- When operating, point the transmitting part of the remote controller in the direction of the receiver.
- The direct transmitting distance of the remote controller is approximately 12 meters.
- The signal cannot be transmitted if something such as curtains blocks the receiver and the remote controller.

### • Installing to a wall or a pillar

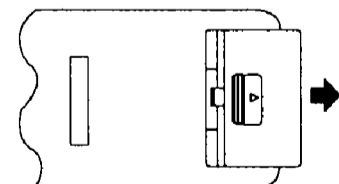
Slide the remote controller into the remote controller holder from the top.



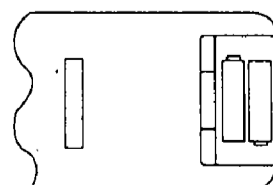
Fix the remote controller holder with the screws.

### • How to insert the batteries

① Open the back cover of the remote controller by sliding it in the direction of the arrow.



② Insert the attached dry cell batteries. Properly insert, set the batteries by matching the (+) and (-) polarity marks as indicated.



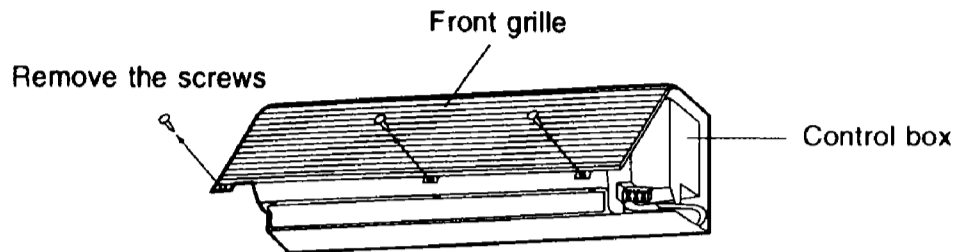
Then close the cover as before.

# RECEIVER INSTALLATION

## (1) Preparations before installation

Install this kit after electric wiring the indoor unit.

- ① Do not attach back in position the right side panel and the control display cover, both of which have been removed for electric wiring. Remove the left side panel too.
- ② Draw out the air filter, and remove the front grille as shown at below.



## (2) Determination of address and MAIN/SUB remote controller.

If setting multiple wireless remote controllers to operate in one room, perform address setting for the receiver and the wireless remote controller. If setting multiple wired remote controllers in one room, change the MAIN/SUB switch of the receiver.

### SETTING PROCEDURE

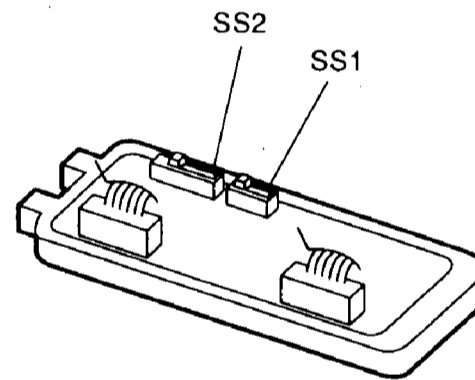
#### ① Setting the receiver

Referring to the table below, set the wireless address switch (SS2) on the transmission PC board that is connected with the wireless display cover.

Unit No.	No. 1	No. 2	No. 3
Wireless address switch (SS2)			

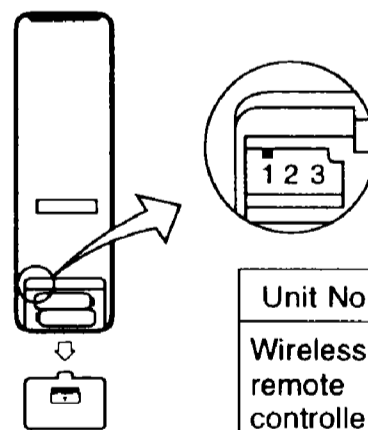
When using both a wired and a wireless remote controller for 1 indoor unit, the wired controller should be set to MAIN. Therefore, set the MAIN/SUB switch (SS1) of the receiver to SUB.

	MAIN	SUB
MAIN/SUB switch (SS1)		



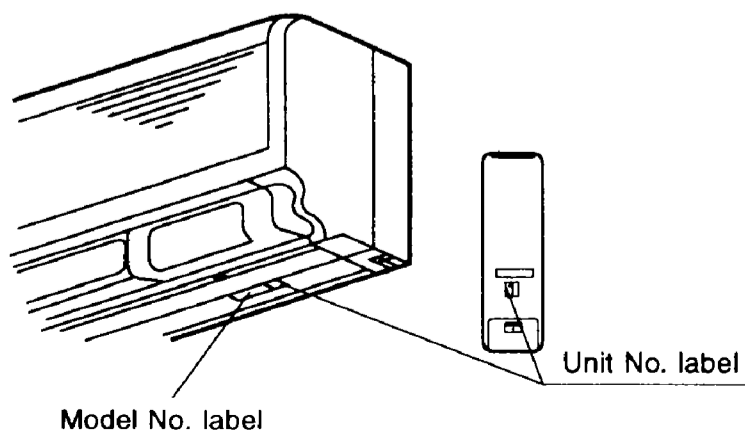
#### ② Setting the address of wireless remote controller (It is factory set to "1")

Remove the back cover on the wireless remote controller and set the wireless remote controller address switch according to the drawing below.



Unit No.	No. 1	No. 2	No. 3
Wireless remote controller address switch			

#### ③ Stick the Unit No. labels next to the Model No. label at the bottom of the indoor unit as well as on the back of the wireless remote controller.



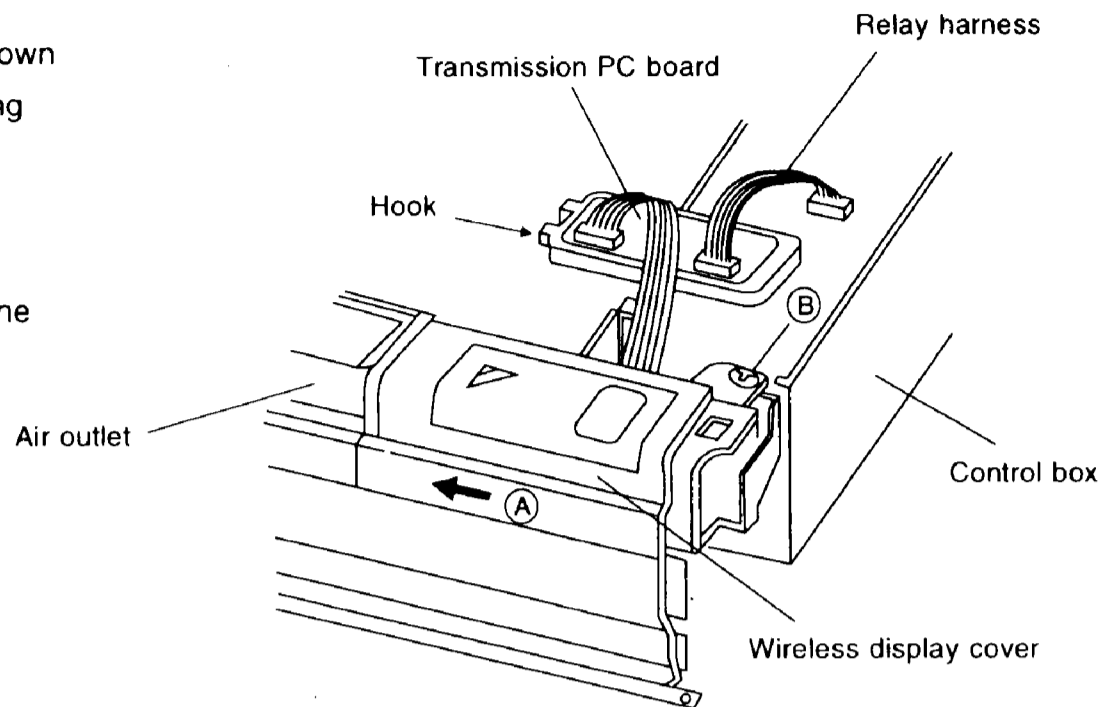
### PRECAUTIONS

Set the Unit No. of the receiver and the wireless remote controller to be equal. If the settings differs, the signal from the remote controller cannot be transmitted.

### (3) Setting up the wireless display cover and the transmission PC board

① To attach the wireless display cover as shown at right, take the reverse steps or detaching the display cover.

- Ⓐ Insert the cover with the arrow facing toward the right hand of the air outlet.
- Ⓑ Fix the cover to the control box with the screws.

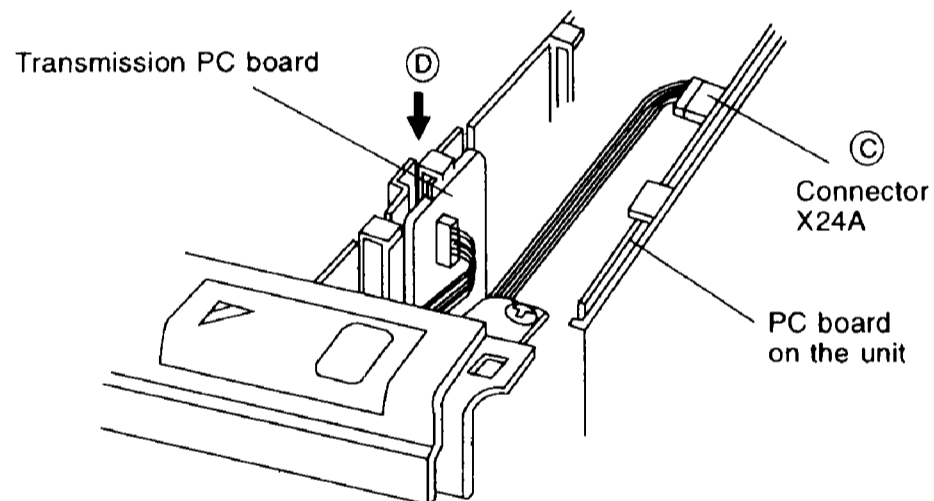


② To attach the transmission PC board, take the following steps.

First connect the relay harness of the transmission PC board to the X24A connector (Ⓒ) on the PC board of the unit.

Then put the transmission PC board, with its hooks upward, on the facing face of the PC board on the unit.

Make sure that the PC board comes on the center of the 3 catches (in the arrow (Ⓓ)).









- ③ Place the front grille first and then the right and left side panels into position.
- ④ Finally attach the air filter in place.

## FIELD SETTING

( If optional accessories are mounted on the indoor unit, the indoor unit setting may have to be changed. Refer to the instruction manual (optional hand book) for each optional accessory.

### Procedure

- ① When in the normal mode, press the "  " button for a minimum of four seconds, and the FIELD SET MODE is entered.
- ② Select the desired MODE NO. with the "  " button.
- ③ Push the "  " button and select the FIRST CODE NO.
- ④ Push the "  " button and select the SECOND CODE NO.
- ⑤ Push the "  " button and the present settings are SET.
- ⑥ Push the "  " button to return to the NORMAL MODE.

(Example) If the time to clean air filter is set to "Filter Contamination-Heavy", set Mode No. to "10", FIRST CODE NO. to "0", and SECOND CODE NO. to "02".

MODE NO.	FIRST CODE NO.	DESCRIPTION OF SETTING	SECOND CODE NO. NOTE)				
			01	02	03		
10	0	Filter Contamination-Heavy/Light (Setting for spacing time of display time to clean air filter) (Setting for when filter contamination is heavy, and spacing time of display time to clean air filter is to be halved)	Light	Approx. 200 hrs.	Heavy	Approx. 100 hrs.	—
	2 (VRV system)	Thermostat Sensor in Remote Controller (Setting for when thermostat sensor in remote controller is not to be used)	Use		Not Use		—
	3	Spacing time of display time to clean air filter count (Setting for when the filter sign is not to be displayed)	Display		Do not display		—
11 (Split system)	0	Setting the number of connected simultaneous operation system indoor units.	Pair		Twin		—
12 (VRV system)	1	ON/OFF Input from Outside (Setting for when forced ON/OFF is to be operated from outside.)	Forced Off		ON/OFF Operation		—
	2	Thermostat Differential Changeover (Setting for when using the remote sensor)	1°C		0.5°C		—
13	0	Air flowrate increase mode (to be set upon user's request)	Standard		A little increase		Increase

NOTE) The SECOND CODE NO. is factory set to "01".

Do not use any settings not listed in Table.

For group control with a wireless remote controller, initial settings for all the indoor units of the group are equal. (For group control, refer to the installation manual attached to the indoor unit for group control.)

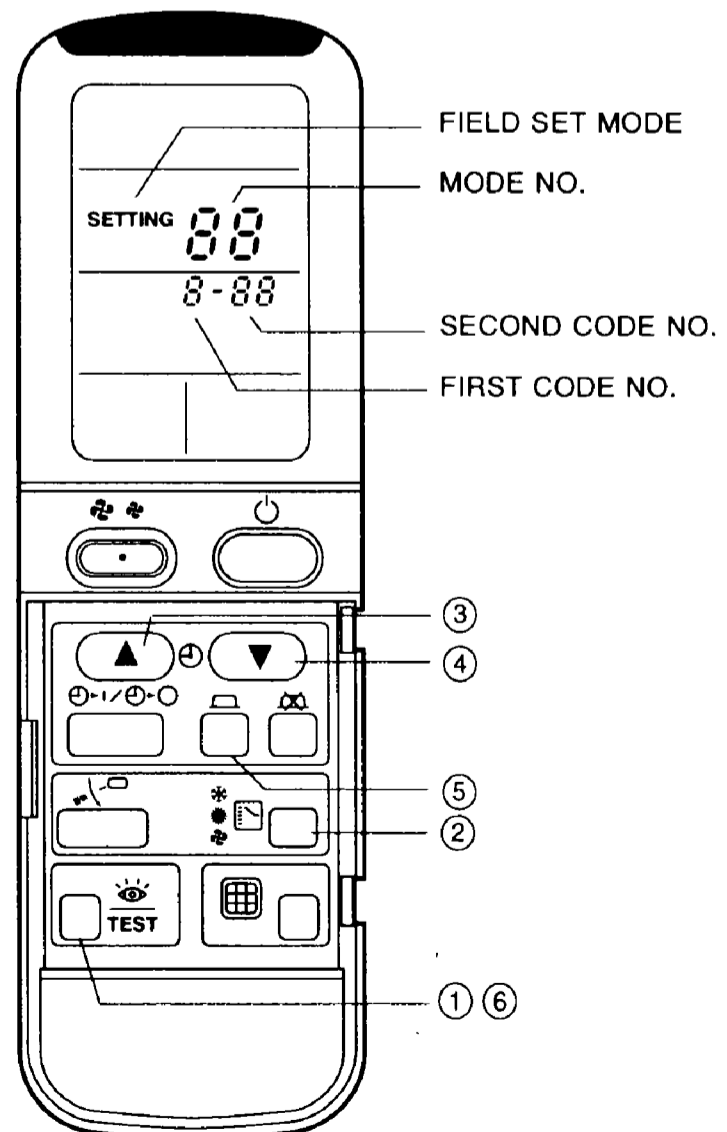
## TEST OPERATION

- Perform test operation according to the instructions in the installation manual attached to the indoor unit.
- After refrigerant piping, drain piping, and electric wiring, operate according to the table to protect the unit.

### < PRECAUTIONS >

1. Refer to malfunction diagnosis label attached to the unit if it does not operate.
2. Refer to the installation manual attached to the outdoor unit for individual operation system types.

Order	Operation
(1)	Open gas side stop valve.
(2)	Open liquid side stop valve.
(3)	Electrify crank case heater for 6 hours.
(4)	Set to cooling with the remote controller and push ON/OFF button to start operation.
(5)	Push INSPECTION/TEST OPERATION button twice and operate in TEST OPERATION mode for 3 minutes.
(6)	Push AIR FLOW DIRECTION ADJUST button and confirm its operation.
(7)	Push INSPECTION/TEST OPERATION button and operate normally.
(8)	Confirm its function according to the operation manual.

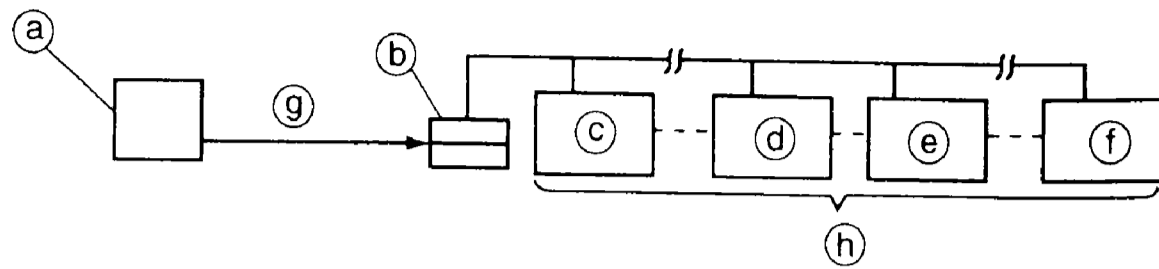


## 2 Central remote controller

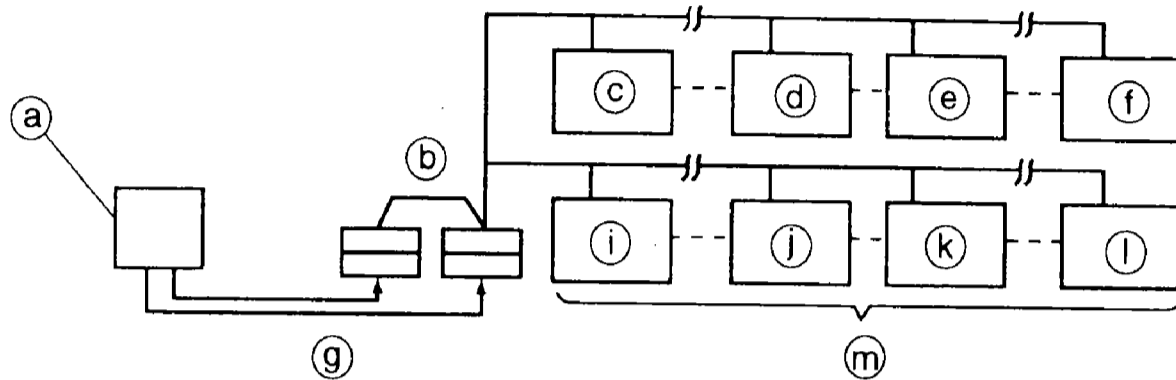
### DCS302B61

#### ★ Operation

- When using 1 central remote controller



- When using 2 central remote controllers



## BEFORE USE

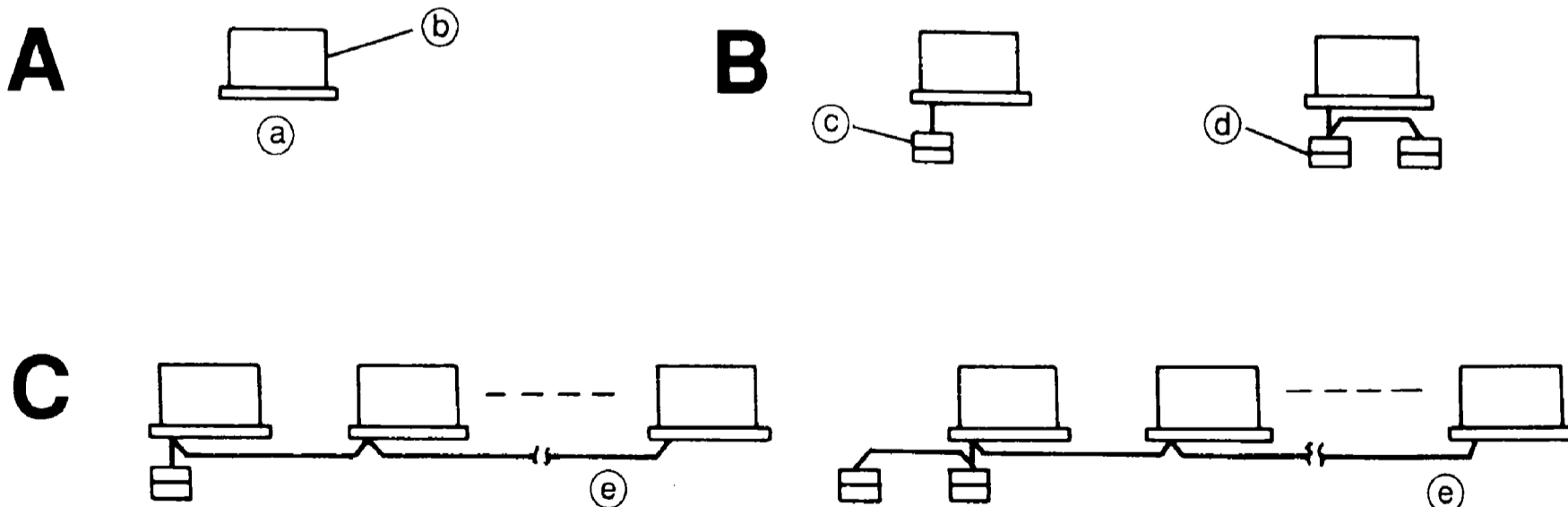
### GENERAL DESCRIPTION OF SYSTEM

For a maximum of 64 groups of indoor unit, unified operation/stop can be performed. When using 2 central remote controllers, unified operation is possible with up to a maximum of 128 groups of indoor units. It can be used to set operation modes by ZONE: operation, stop, operation controlled by timer, ON/OFF control possible/impossible; as well as, to set operating state: temperature setting, etc.

It can display the operation state such as operation modes and preset temperature by group.

Furthermore, the unit can be connected with an external key system or host computer monitor panel to enable forced ON/OFF input (no-voltage normally open contactor). (This unit cannot be used concurrently with the wiring adaptor for electrical appendieces [optional accessory].)

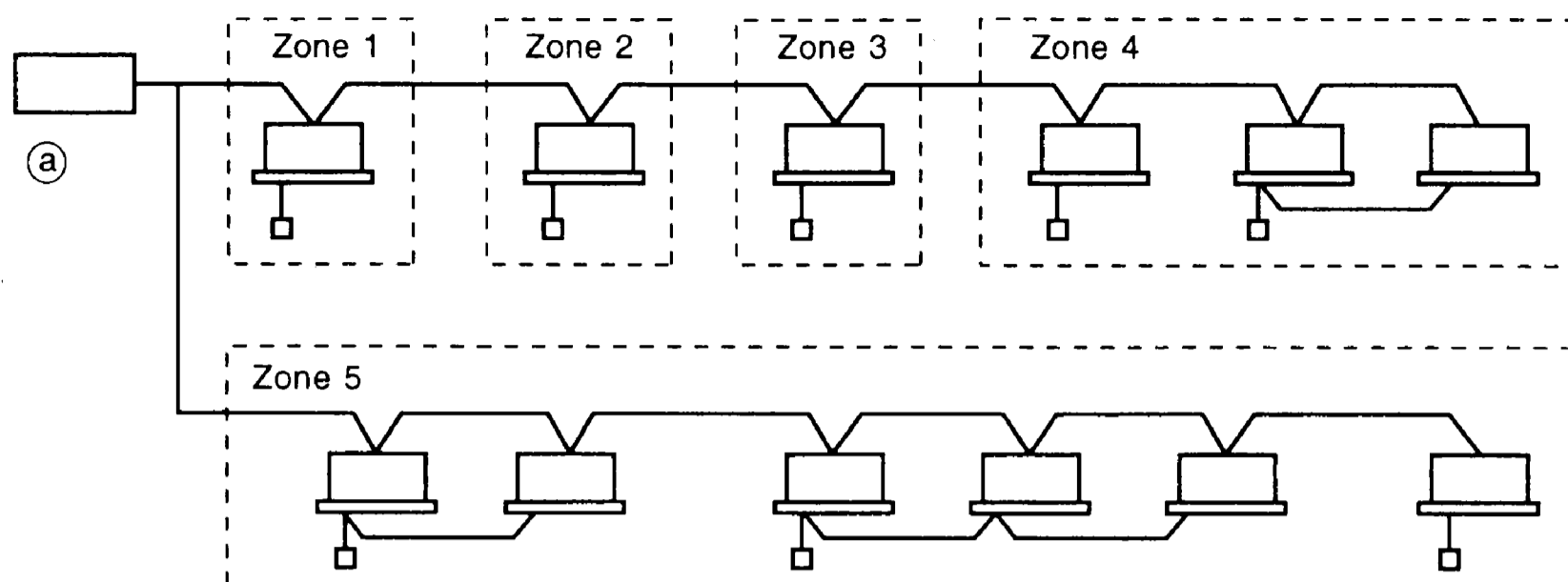
- |  |                               |                      |
|--|-------------------------------|----------------------|
| (a) Host computer monitor panel, etc.                      | (b) Central remote controller | (c) Group No. 1 - 00 |
| (d) Group No. 1 - 15                                       | (e) Group No. 2 - 00          | (f) Group No. 4 - 15 |
| (Stops with command from either central remote controller) |                               |                      |
| (g) Forced ON/OFF command                                  | (h) A maximum of 64 groups    |                      |
| (i) Group No. 5 - 00                                       | (j) Group No. 5 - 15          | (k) Group No. 6 - 00 |
| (l) Group No. 8 - 15                                       |                               |                      |
| (m) A maximum of 128 groups                                |                               |                      |



\* GROUP OF INDOOR UNIT refers to the above.

**A:** A single indoor unit without remote controller      **B:** A single indoor unit controlled by one or two remote controllers  
**C:** Maximum of 16 indoor units, group-controlled by one or two remote controllers

- |                                |                 |                       |                            |
|--------------------------------|-----------------|-----------------------|----------------------------|
| (a) Remote controller not used | (b) Indoor unit | (c) Remote controller | (d) Two remote controllers |
| (e) A maximum of 16 units      |                 |                       |                            |



\* **Zone** control from the central remote controller

**Zone** control is available from the central remote controller. With it, it is possible to make unified settings for multiple groups, so setting operations are greatly simplified.

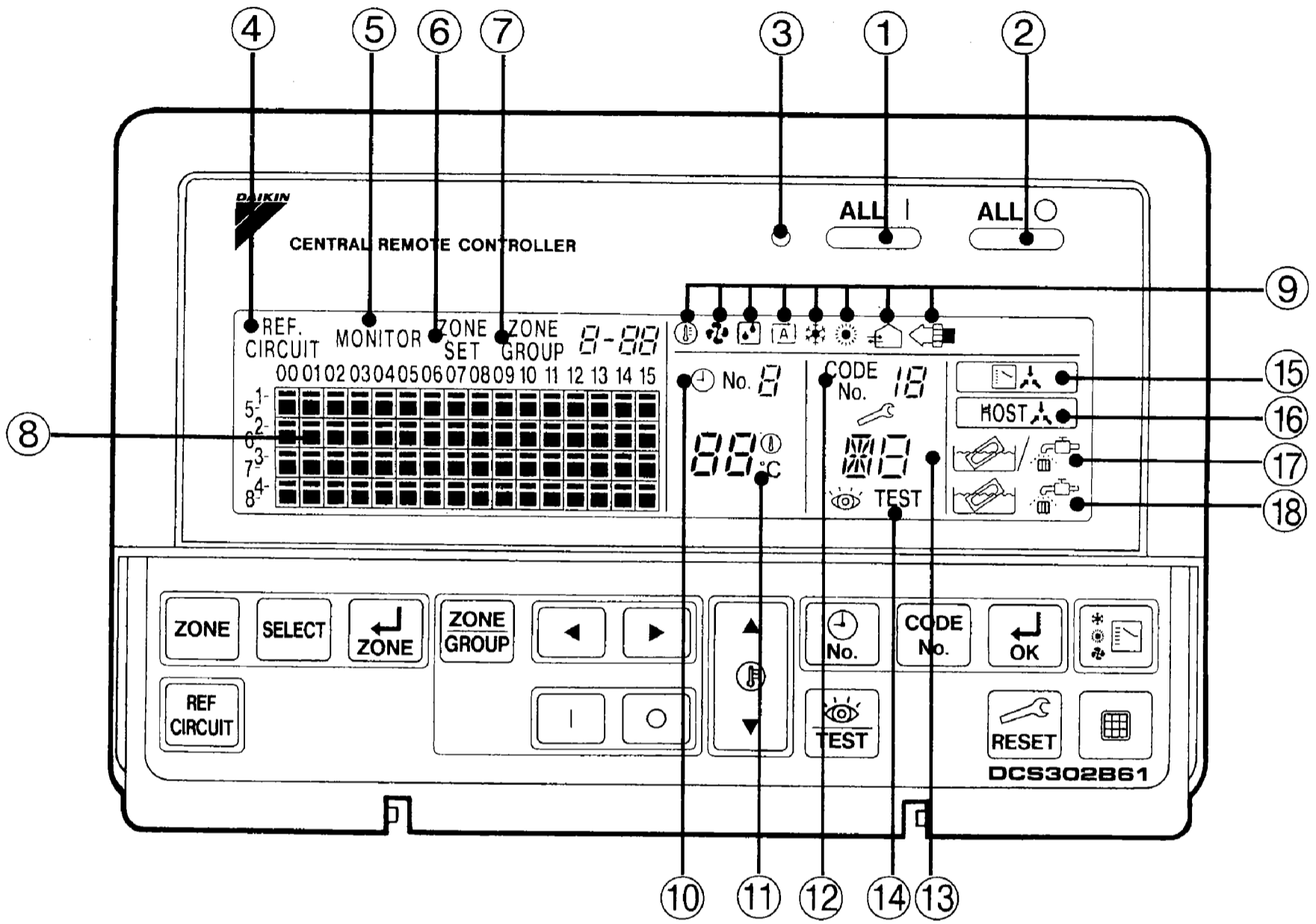
- Any setting you make within a given zone will apply to all groups in the said zone.
- A maximum of 64 zones can be set from a single central remote controller. (Each zone contains a maximum of 64 groups.)
- Zones can be set randomly from the central remote controller.

(a) Central remote controller

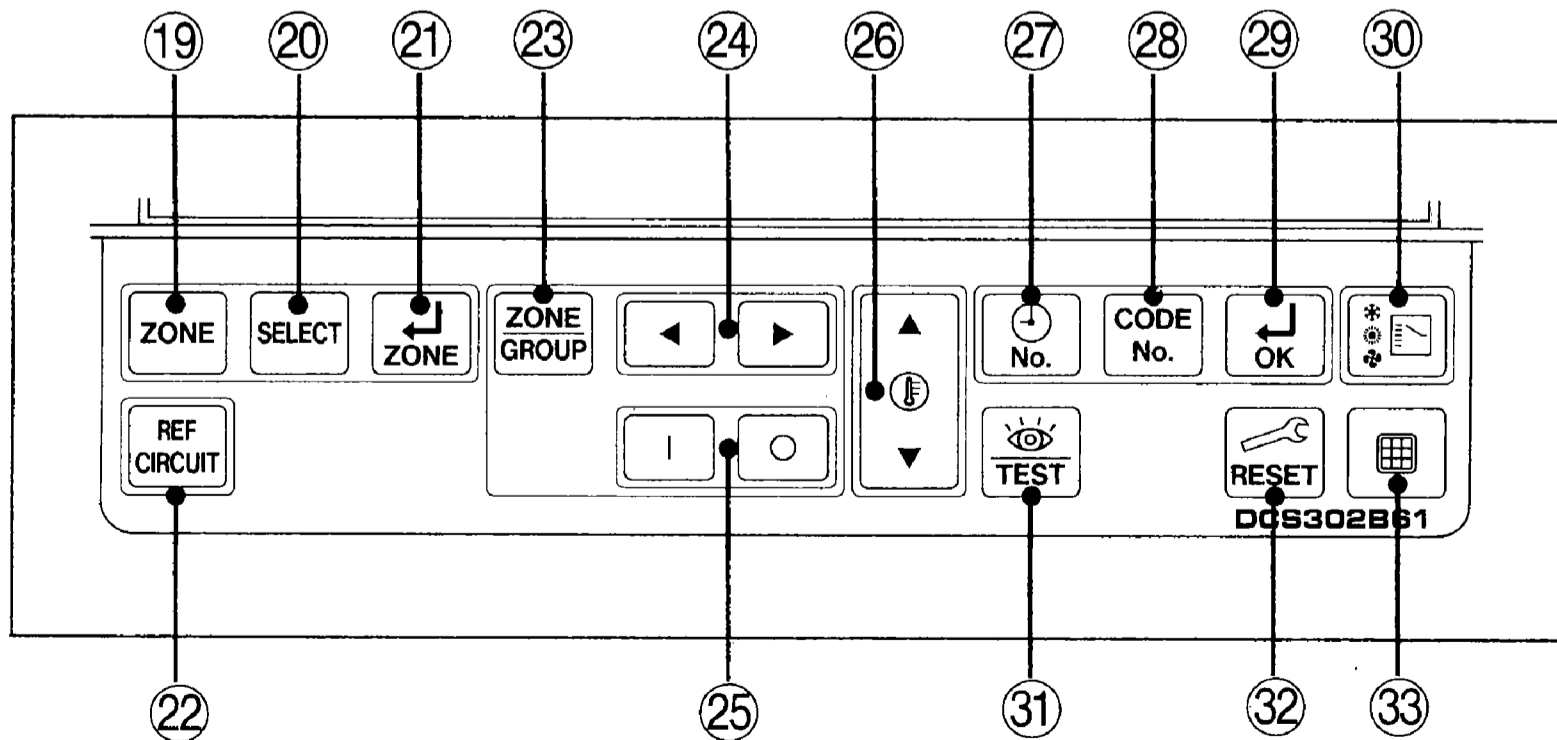
## CAUTIONS DURING USE

- Do not tamper with the inner mechanism.  
Do not remove the front panel. Tampering with the inner mechanism is dangerous and may damage equipment. For inspection and adjustment, contact your DAIKIN dealer.
- Avoid places where the unit may be contacted by water.  
Water penetrating the inner mechanism may cause electrical leakage, or render electric parts defective.
- Do not press the button on the central remote controller with a pointed hard tool.  
This may damage the central remote controller.
- Avoid direct exposure to sunlight.  
Direct sunlight may discolor the LCD and obscure the image.
- Do not wipe the surface of the operation panel with benzene, thinner, chemically treated dust cloth, etc.  
This may cause discoloring or peeling. To clean, moisten a cloth with a neutral cleanser diluted in water, rinse and wipe. Blot adhering water with a dry cloth.
- Never pull or twist the electric wire of a remote controller.  
It can cause the unit to malfunction.
- Never inspect or service the central remote controller by yourself.  
Ask a qualified service person to perform this work.

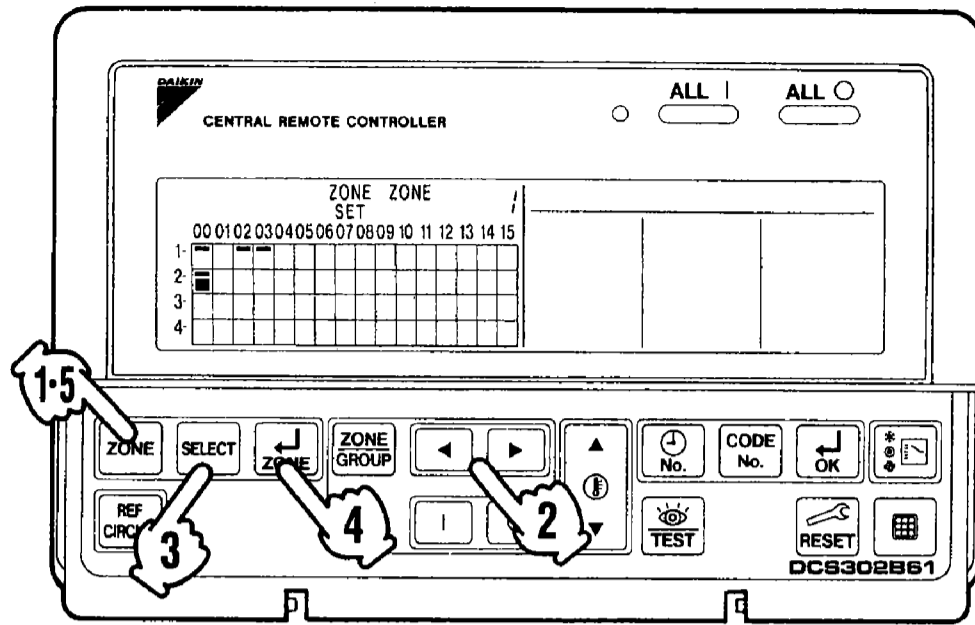
# 1



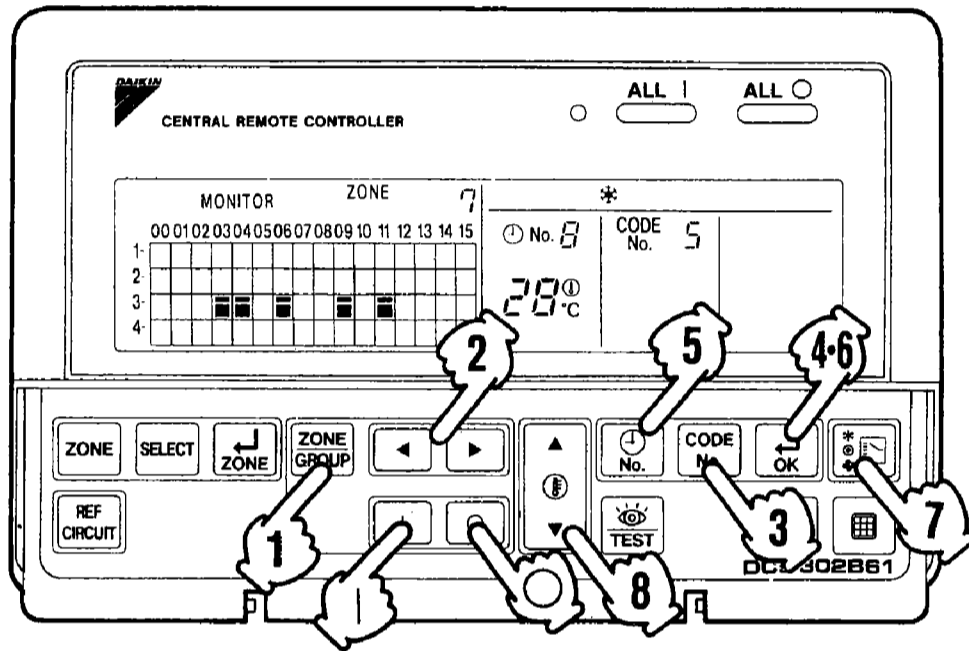
# 2



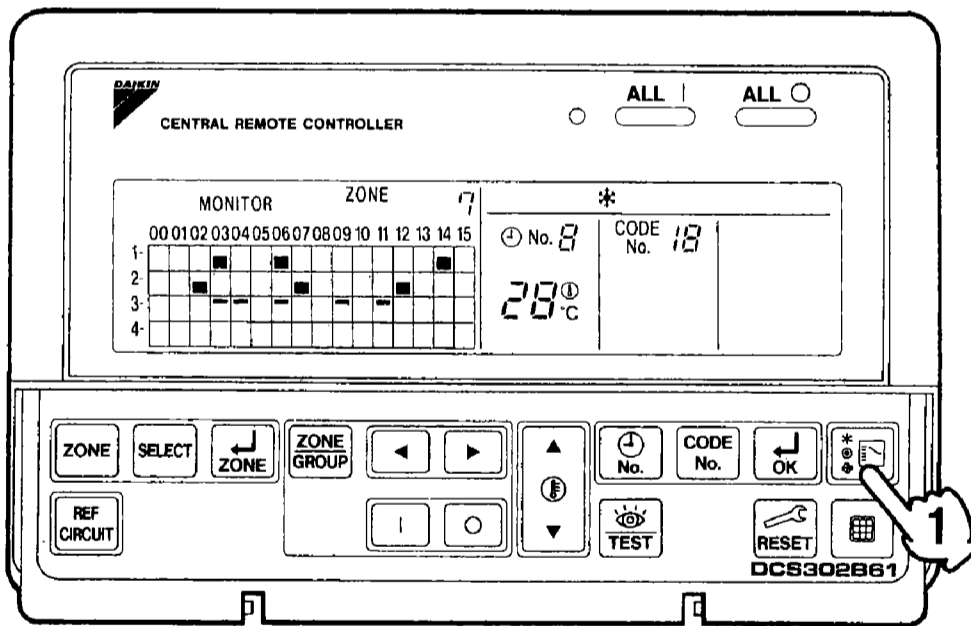
3



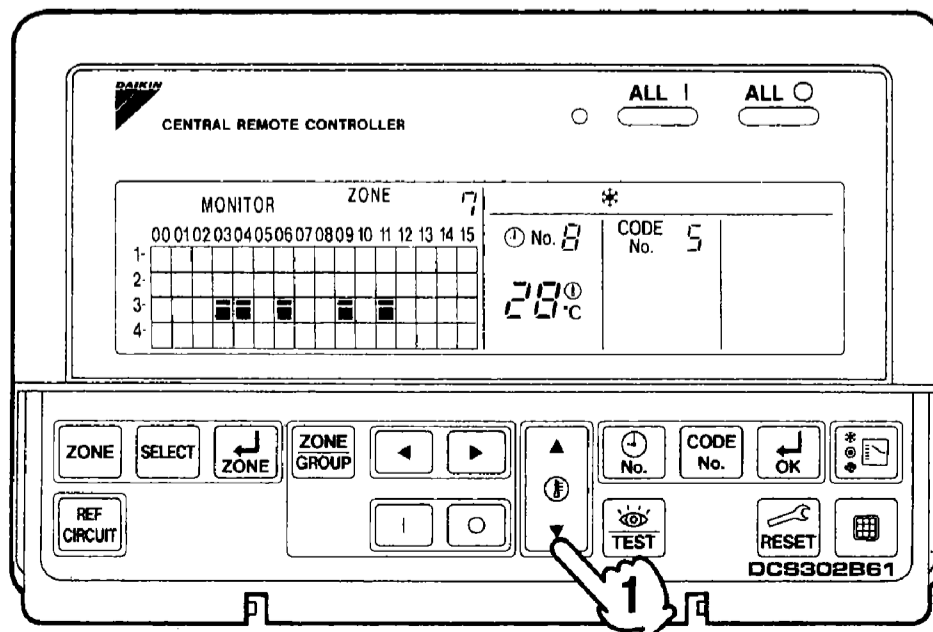
4



5

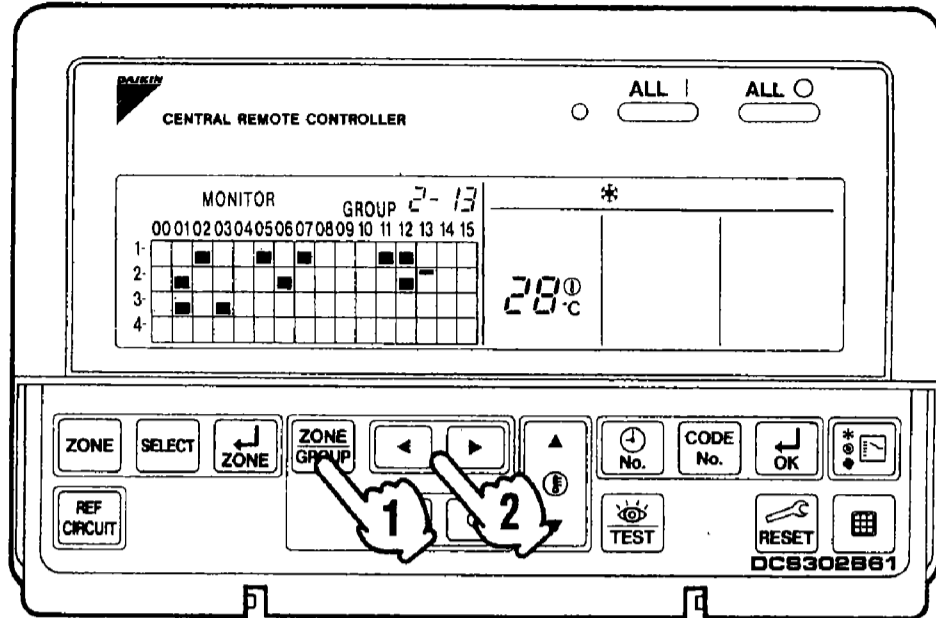


6

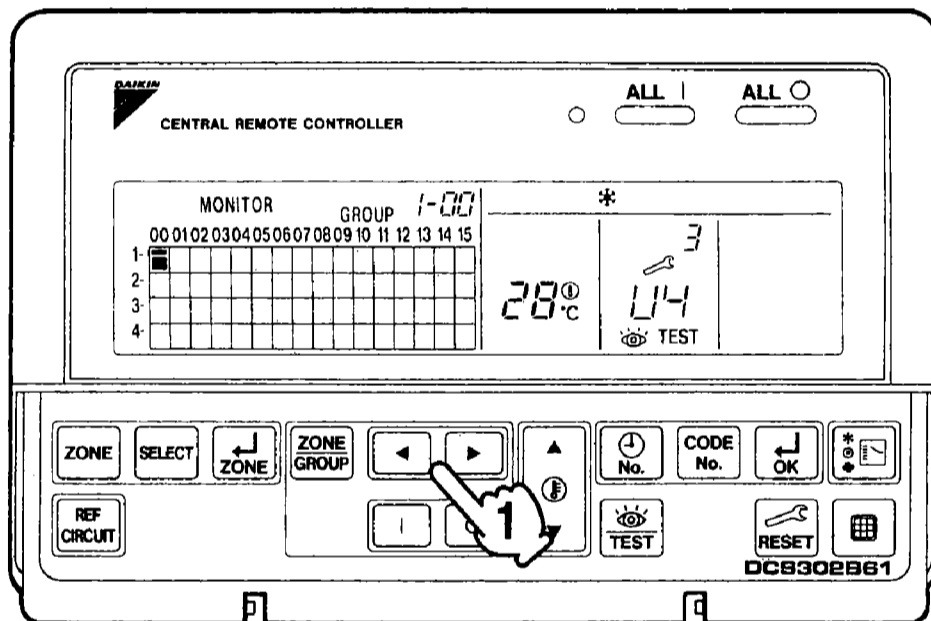




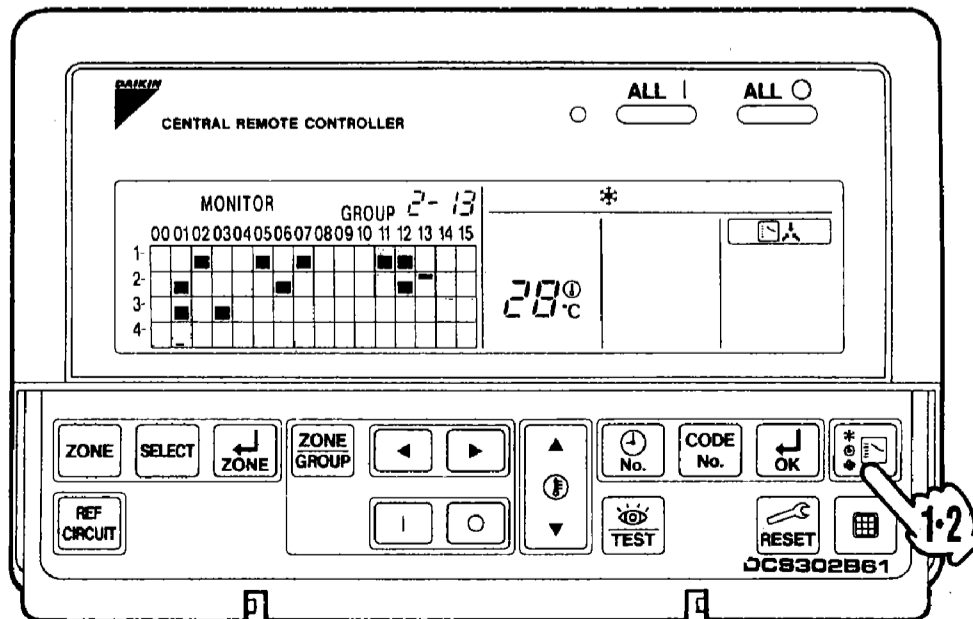
7



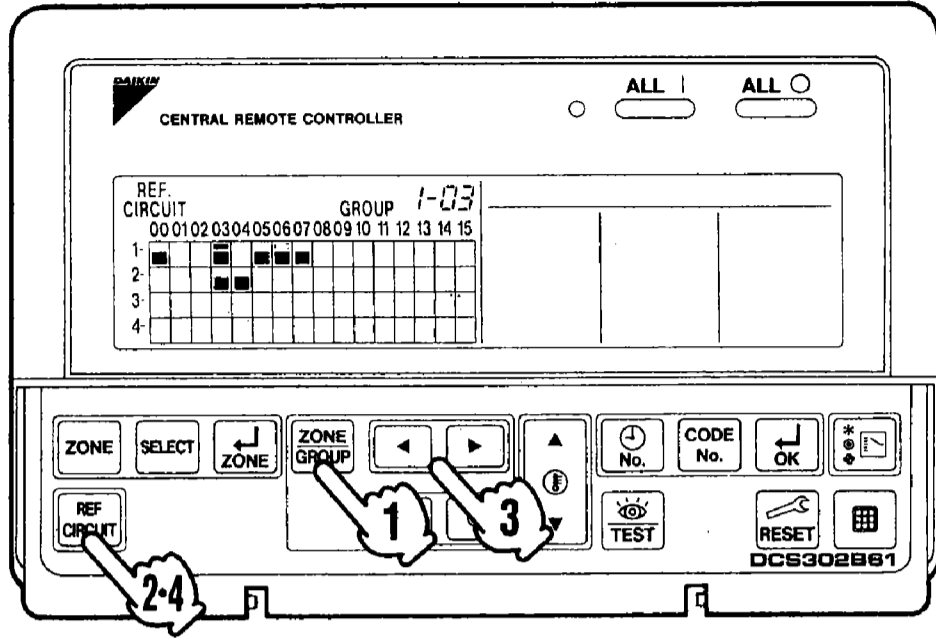
8



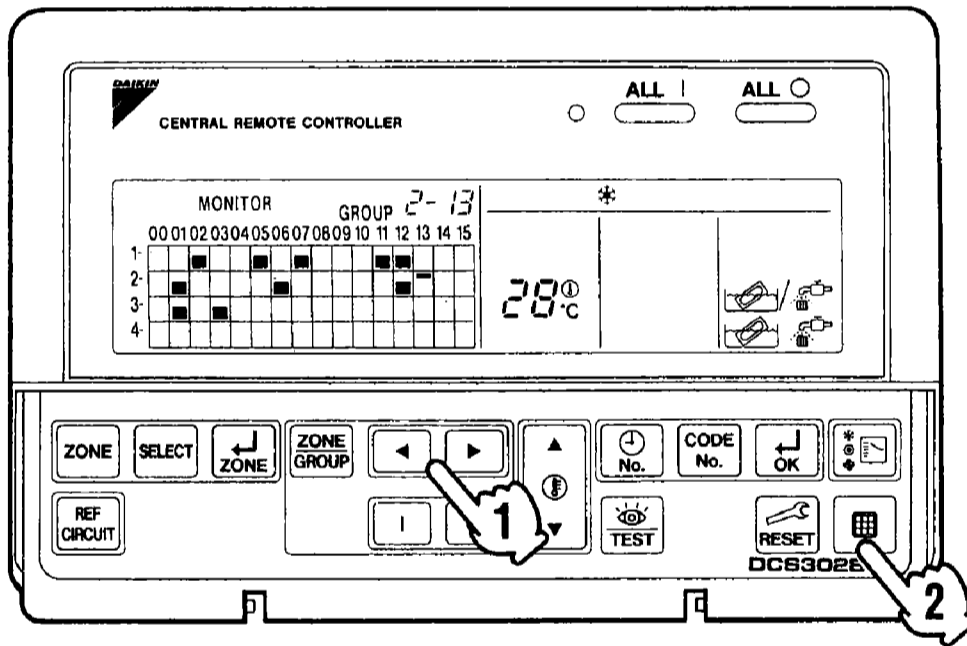
9



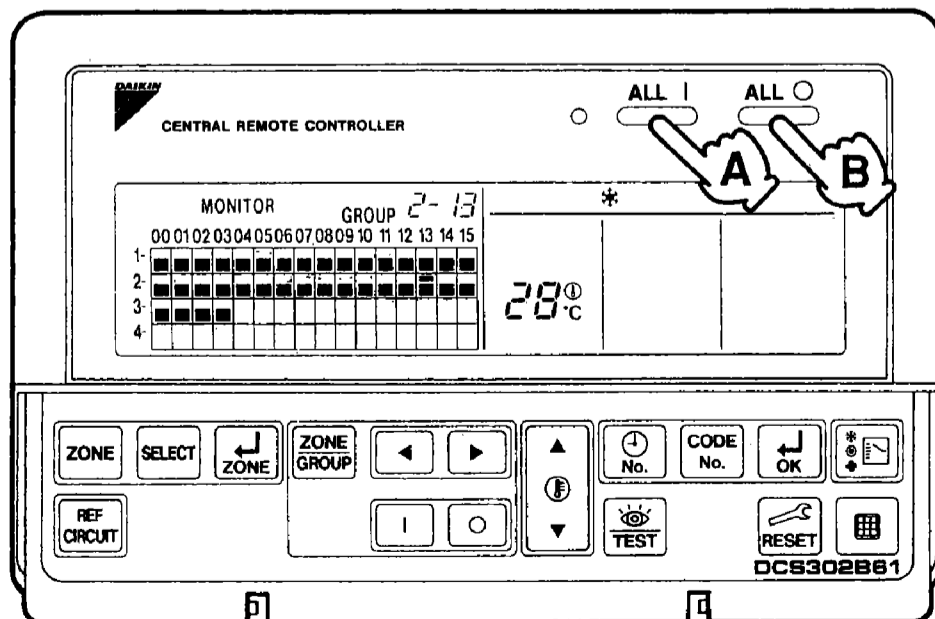
10



11



12



# FEATURES AND FUNCTIONS

## ■ Operation menu

This central remote controller enables the individual operation/stop by zone, and unified operation/stop. ON/OFF operation controlled by timer is possible in conjunction with the schedule timer (optional accessory).



See page  
74—75, 83.

## ■ Various operation modes.

You can operate the system from both this unit and the remote controller, so to enable various operation control patterns. Twenty different operation modes are available including five operation patterns: ON/OFF control impossible by remote controller, only OFF control possible by remote controller, centralized, individual and centralized (ON/OFF control possible by remote controller only with the timer ON); and temperature setting possible/impossible by remote controller and operation mode selecting possible /impossible by remote controller.



See page 76.

## ■ Zone control for simpler operation

You can control a maximum of 64 groups of indoor units by using this central remote controller. You don't have to repeat the same setting operations by group because you can make each of the following settings by zone.

Also, there is a function which allows you to unify settings in all groups. (When set to Zone No. 0, all the below settings are unified for all groups.)

- Operation mode
- Control mode
- Setting temperature
- Programming time No. (Used in conjunction with the schedule timer)



See page  
74—80.

## ■ Monitor and display operating conditions of indoor units by group

You can display operating conditions such as operation mode and preset temperature; maintenance information such as time to clean, etc.; and information on trouble such as malfunction codes.

\* "Time to clean" sign refers to the following functions.

- Display the time to clean air filter and the air cleaner element of electric dust collector for each group.
- Display the time to clean when signaled from any given group.



See page  
80—82.

## ■ Function of refrigerant system display




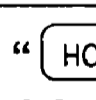










This display helps you understand, at a glance, the indoor units sharing the same outdoor unit and the particular indoor unit among them that is set as the master remote controller.

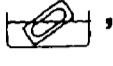



See page 82.

- Utilizing one of the PC board adaptors (optional accessories) will enable you to combine this unit with the split A/C units and unitary A/C.  
However, be sure to refer to the installation manual attached to each PC board adaptor for function limitations.

# NAMES AND FUNCTIONS OF THE OPERATING SECTION (Fig. 1, 2)

①	<b>UNIFIED OPERATION BUTTON</b> Press to operate all indoor units.	⑪	<b>“88<sup>⑩</sup>°C” DISPLAY (PRESET TEMPERATURE)</b> Displays the preset temperature.
②	<b>UNIFIED STOP BUTTON</b> Press to stop all indoor units.		<b>“CODE No. 18” DISPLAY (CONTROL MODE)</b> Displays codes on how to control equipment (ON/OFF control impossible by remote controller, centralized, individual etc.). Displays the No. of the particular unit that has stopped due to malfunction.
③	<b>OPERATION LAMP (RED)</b> Lit while any of the indoor units under control is in operation.	⑫	<b>“” DISPLAY (MALFUNCTION CODE)</b> Displays the contents of a malfunction. The lamp flashes when a malfunction stops operation. The contents of the current malfunction are displayed in the inspection mode.
④	<b>“<sup>REF.</sup>CIRCUIT” DISPLAY (REFRIGERANT SYSTEM DISPLAY)</b> The indication in the square is lit while the refrigerant system is being displayed.	⑬	<b>“ TEST” DISPLAY (INSPECTION/TEST)</b> Press the inspection/test operation button. Either the inspection or test lamp lights up.
⑤	<b>“MONITOR” DISPLAY (OPERATION MONITOR)</b> The lamp is lit while operation is being monitored.	⑭	<b>“” DISPLAY (CHANGEOVER UNDER CONTROL)</b> Cool/heat selection is not possible for either the zone or the group where this particular display appears.
⑥	<b>“<sup>ZONE</sup>SET” DISPLAY (ZONE SETTING)</b> The lamp is lit while setting zones.	⑮	<b>“” DISPLAY (UNDER HOST COMPUTER INTEGRATED CONTROL)</b> Setting is not possible while this display is being displayed.
⑦	<b>“ZONE” “GROUP” DISPLAY (ZONE/GROUP)</b> Indicates the particular zone or group being displayed.	⑯	<b>“” DISPLAY (TIME TO CLEAN)</b> Displayed to notify the user it is time to clean the air filter or air cleaner element of a particular group.
⑧	<b>GROUP NO. IN OPERATION</b> Each square displays the state corresponding to each group.	⑰	
⑨	<b>“” “” “” “” “” “” “” “” DISPLAY (OPERATION MODE)</b> Displays operating state.	⑱	
⑩	<b>“ No.” DISPLAY (TIME NO.)</b> Displays the operation timer No. when used in conjunction with the schedule timer.	⑲	

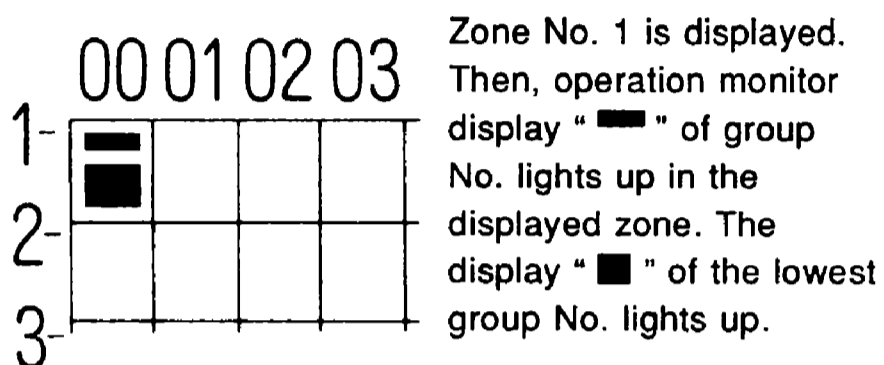
⑱	  <b>DISPLAY (TIME TO CLEAN AIR CLEANER ELEMENT/ TIME TO CLEAN AIR FILTER)</b>	⑳	<b>TEMPERATURE SETTING BUTTON</b>
	Displayed to notify the user it is time to clean the air filter or air cleaner element of the group displayed.		Press to set temperature.
⑲	<b>ZONE SETTING BUTTON</b>	㉑	<b>TIME NO. BUTTON</b>
	Turns zone setting mode ON/OFF.		Selects time No. (Use in conjunction with the schedule timer only).
㉒	<b>SELECTOR BUTTON</b>	㉒	<b>CONTROL MODE BUTTON</b>
	Selects the group to be assigned to a zone.		Selects control mode.
㉓	<b>ZONE OPERATION ON/OFF BUTTON</b>	㉓	<b>TIMER ON BUTTON</b>
	Finalizes the zone.		Sets control mode and time No.
㉔	<b>ZONE OPERATION ON/OFF BUTTON</b>	㉔	<b>OPERATION MODE SELECTOR BUTTON</b>
	Finalizes the zone.		See page 79.
㉕	<b>ZONE OPERATION ON/OFF BUTTON</b>	㉕	<b>INSPECTION/TEST OPERATION BUTTON</b>
	Finalizes the zone.		Press to run inspection or test run.
㉖	<b>ZONE OPERATION ON/OFF BUTTON</b>	㉖	<b>CLEARING BUTTON FOR MALFUNCTION CODE MEMORY</b>
	Finalizes the zone.		Press to clear malfunction code.
㉗	<b>ZONE OPERATION ON/OFF BUTTON</b>	㉗	<b>FILTER SIGN RESET BUTTON</b>
	Finalizes the zone.		See page 82.
㉘	<b>ZONE OPERATION ON/OFF BUTTON</b>	㉘	<b>ON/OFF BUTTON</b>
	Finalizes the zone.		Starts/stops operation by zone.

- (Note)
1. Please note that all the displays in the figure appear for explanation purposes or when the cover is open.
  2. If the unit is used in conjunction with other optional central controllers, the OPERATION LAMP of the unit that is not under operation control may light up and go out a few minutes behind schedule. This shows that the signal is being exchanged, and does not indicate any failure.

## ZONE SETTING (Fig. 3)

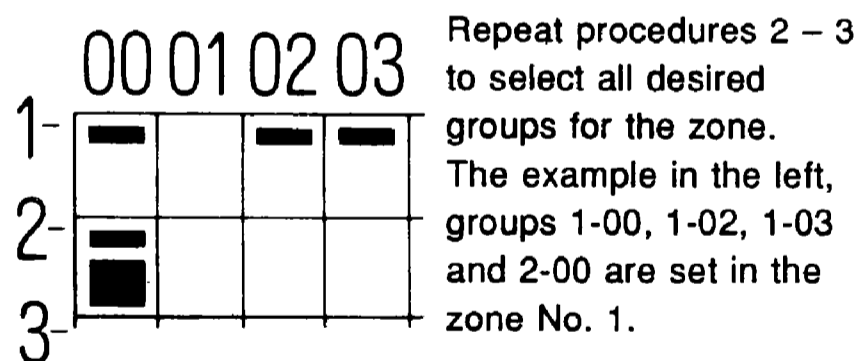
You can set multiple groups under a single zone to control them by zone. This equipment is factory set for 64 zones of 1 group per every zone at the time of shipment.

**1** Press the **ZONE SETTING BUTTON**, and “**ZONE SET**” is displayed.

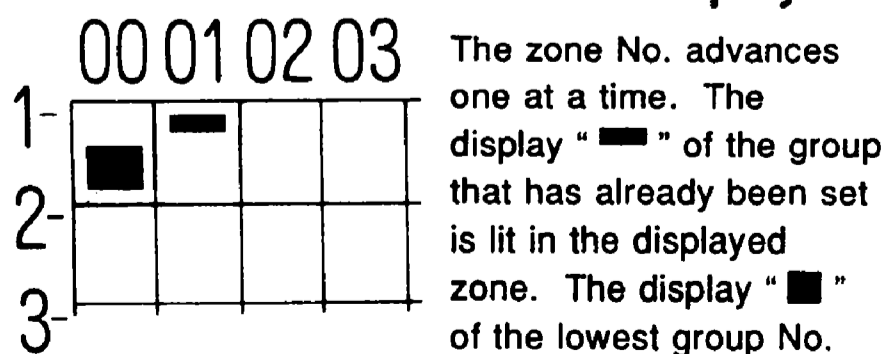


**2** Press the **ADVANCE/BACKWARD BUTTON** to move the display “■” to the group of the desired zone. Holding the button down will quickly move the display.

**3** Press the **SELECTOR BUTTON** to set the above group in the zone. The display “■” of the selected group lights up.



**4** Press the **ZONE OPERATION ON/OFF BUTTON** to finalize the zone. This zone becomes finalized, and the next zone No. is displayed.




lights up again. Set the other zones as well following procedures 2 – 4.

In the above example, the zone No. 2 is displayed. Then, the display “■” of the lowest group No. that has already been set lights up.

**5** Press the **ZONE SETTING BUTTON** again, to finish zoning.

The current display goes out, and the normal display appears.

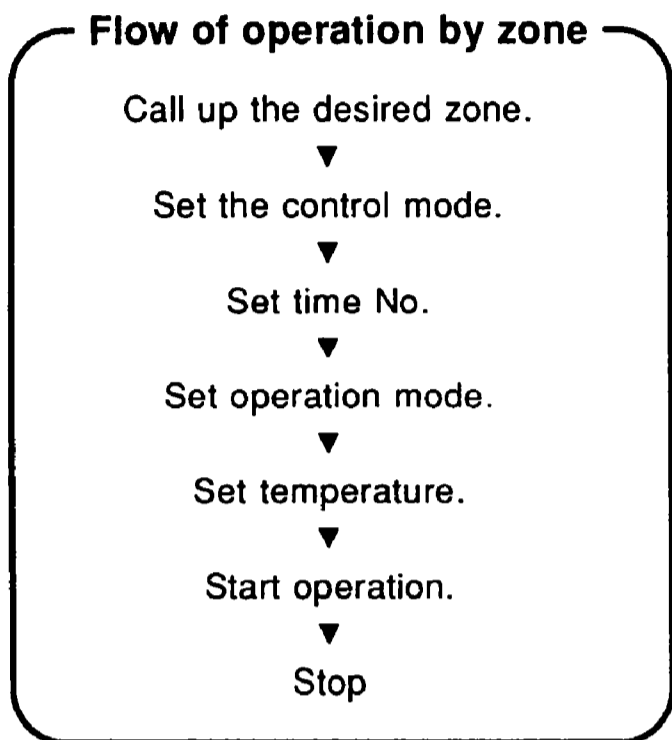
### NOTES

- To clear all registered zones Display “**ZONE SET**”. Then, hold down both  and ALL ○ for about 4 seconds. This will clear all registered zones.
- If you have set a group in the wrong zone, reset it in the correct zone. (The last zone set is judged to be effective.)
- You cannot set the same group in multiple zones.
- When you turn ON the power, the system may display “88” for approximately one minute and may not respond to operation until all the liquid crystal display appears.
- Unless operated from within one minute from when the display of zoning appears, the display will automatically revert back to the “group” display.
- A single setting will simultaneously determine the same setting of all the groups in the zone. So, pay attention to the following points in setting the zone.
  - The control mode must be the same for all groups in the zone.
  - The scheduled operation must be the same for all groups in the zone, if the operation is controlled by the timer.
  - The cool/heat operation mode must be the same for all groups in the zone.
  - The preset temperature must be the same for all groups in the zone.
 

Note) Be sure to select the “--” in executing the operation by zone, as well as to set the operation mode and the temperature setting unless the uniform operation is performed in the above 3 and 4. (See page 74.)

# OPERATION

## OPERATION BY ZONE (Fig. 4)



**1** Press the **ZONE/GROUP CHANGEOVER BUTTON**, to call up the display of zoning.

MONITOR		ZONE															
		00	01	02	03	04	05	06	07	08	09	10	11	12	13	14	15
1-																	
2-																	
3-																	
4-																	

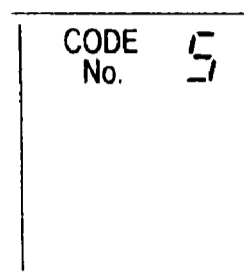
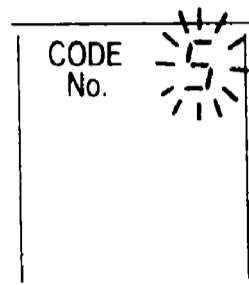
The display "■" of the group set in the display zone lights up.

**2** Press the **ADVANCE/BACKWARD BUTTON**, to select the zone No. Holding it down will quickly move the display.

**3** Press the **CONTROL MODE BUTTON**, to call up the desired code No. (See page 76.) Following the change, the display flashes.

Setting is not possible when using a data station or parallel interface.

**4** Press the **TIMER ON BUTTON**. Press the **TIMER ON BUTTON** within 10 seconds after the code No. is displayed. The display stops flashing and lights up solidly.



The display returns to its original state after no less than 10 seconds.

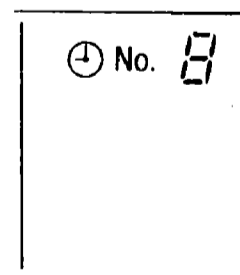
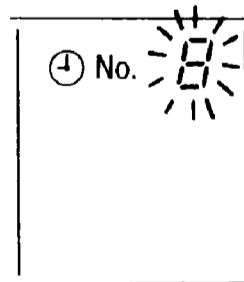
(only in conjunction with the schedule timer)

**5** Press the **TIME No. BUTTON**, to select the desired time No.. When you change the setting, the display flashes. If you don't wish to program the NOITG time, set timer No. to "—".

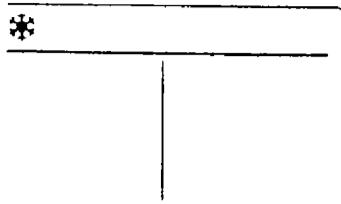
Check the timer No. of the schedule timer. If the schedule timer is not programmed, set the program in accordance with the instruction manual of schedule timer.

**6** Press the **TIMER ON BUTTON**, to finalize the time No. The display flashes, and then lights up solidly. Press the **TIMER ON BUTTON** within 10 seconds after the time No. is displayed.

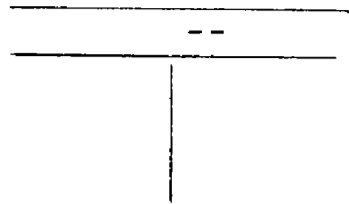
The display returns to its original state after no less than 10 seconds.



**7** Press the **OPERATION MODE SELECTOR BUTTON**, to call up the desired mode. If you don't wish to execute the unified setting in the zone, set it to "—". (See page 79 for further details.)



Cooling mode is selected.



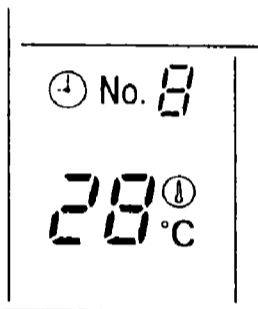
Unified operation is not set within the zone.

**8** Press the **TEMPERATURE SETTING BUTTON**.

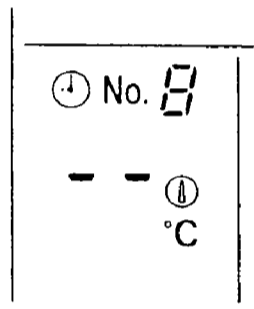
Each time you press the “▲”, the temperature rises by 1°C.

Each time you press the “▼”, the temperature falls by 1°C.

If you don't wish to execute the unified setting in the zone, set it to “--”. (See page 80 for further details.)



28°C is selected.



Unified operation is not set within the zone.

**(When execute operation/stop by zone)**

**1** Press the **ON BUTTON**. The operation lamp lights up, and then the display “■” of the corresponding group appears.

MONITOR		ZONE															
		00	01	02	03	04	05	06	07	08	09	10	11	12	13	14	15
1-																	
2-																	
3-				■	■		■			■		■					
4-																	

**0** Press the **OFF BUTTON**.

Unless operated from within one minute from when the display of zoning appears, the display will automatically revert back to the “group” display.



# OPERATION MODE

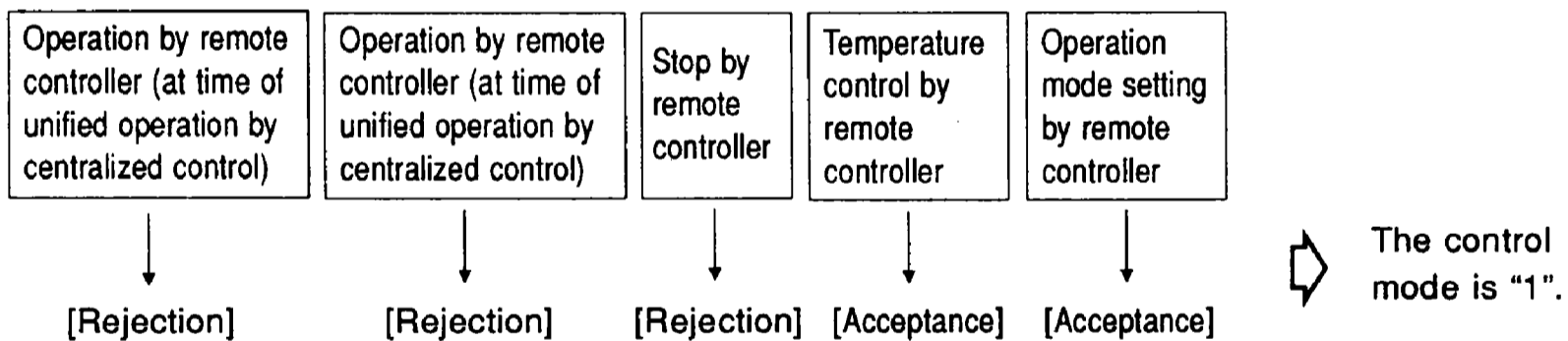
The following five operation control modes can be selected along with the temperature setting and operation mode by remote controller, for a total of twenty different modes. These twenty modes are set and displayed with control modes of 0 to 19. (For further details, see **EXAMPLE OF OPERATION SCHEDULE** on the next page.)

- ON/OFF control impossible by remote controller . . . . . Use this mode when operating and stopping from the central remote controller only. (ON/OFF control by the remote controller is disabled.)
- Only OFF control possible by remote controller . . . . . Use this mode when executing the operation only by the central remote controller, and executing only the stop by remote controller.
- Centralized . . . . . Use this mode when executing the operation only by the central remote controller, and executing operation/stop freely by remote controller during the preset hours.
- Individual . . . . . Use this mode when executing operation/stop both by central remote controller and remote controller.
- Timer operation possible by remote controller . . . . . Use this mode when executing operation/stop by remote controller during the preset hours, and not starting operation by the central remote controller at the programmed time of system start.

## HOW TO SELECT THE CONTROL MODE

- Select whether to accept or to reject the operation from the remote controller regarding the operation, stop, temperature setting and operation mode setting, respectively, and determine the particular control mode from the rightmost column of the table below.

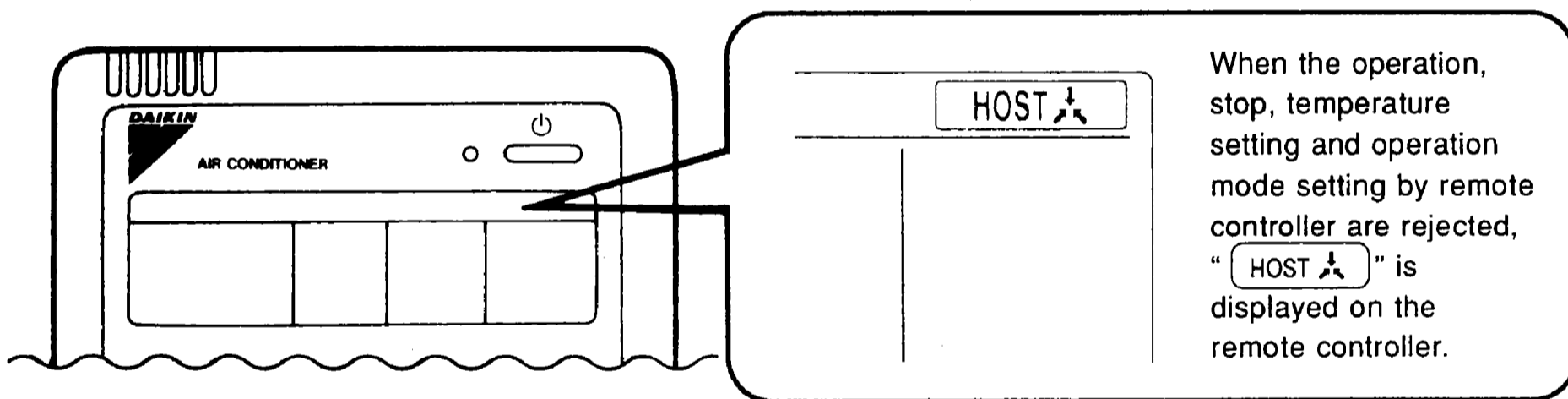
Example



Operation mode	Control by remote controller					Control mode
	Operation		Stop	Temperature control	Operation mode setting	
	Unified operation, individual operation by central remote controller, or operation controlled by timer	Unified stop, individual stop by central remote controller, or timer stop				
ON/OFF control impossible by remote controller	Rejection (Example)	Rejection (Example)	Rejection (Example)	Rejection	Acceptance	0
				Rejection	Rejection	10
				Acceptance (Example)	Acceptance (Example)	<u>1</u> (Example)
				Acceptance	Rejection	11
Only OFF control possible by remote controller			Acceptance	Rejection	Acceptance	2
				Rejection	Rejection	12
				Acceptance	Acceptance	3
				Acceptance	Rejection	13

Operation mode	Control by remote controller					Control mode
	Operation		Stop	Temperature control	Operation mode setting	
	Unified operation, individual operation by central remote controller, or operation controlled by timer	Unified stop, individual stop by central remote controller, or timer stop				
Centralized	Acceptance	Rejection (Example)	Acceptance	Rejection	Acceptance	4
					Rejection	14
				Acceptance	5	
Individual		Rejection		Acceptance	6	
				Rejection	16	
		Acceptance		Acceptance	7	
Timer operation possible by remote controller	Acceptance (During timer at ON position only)	Rejection (During timer at OFF position)	Acceptance	Rejection	Acceptance	8
					Rejection	18
				Acceptance	Acceptance	9
				Rejection	19	

Note) Do not select the timer operation possible without the remote controller. In this case, timer operation is disabled.

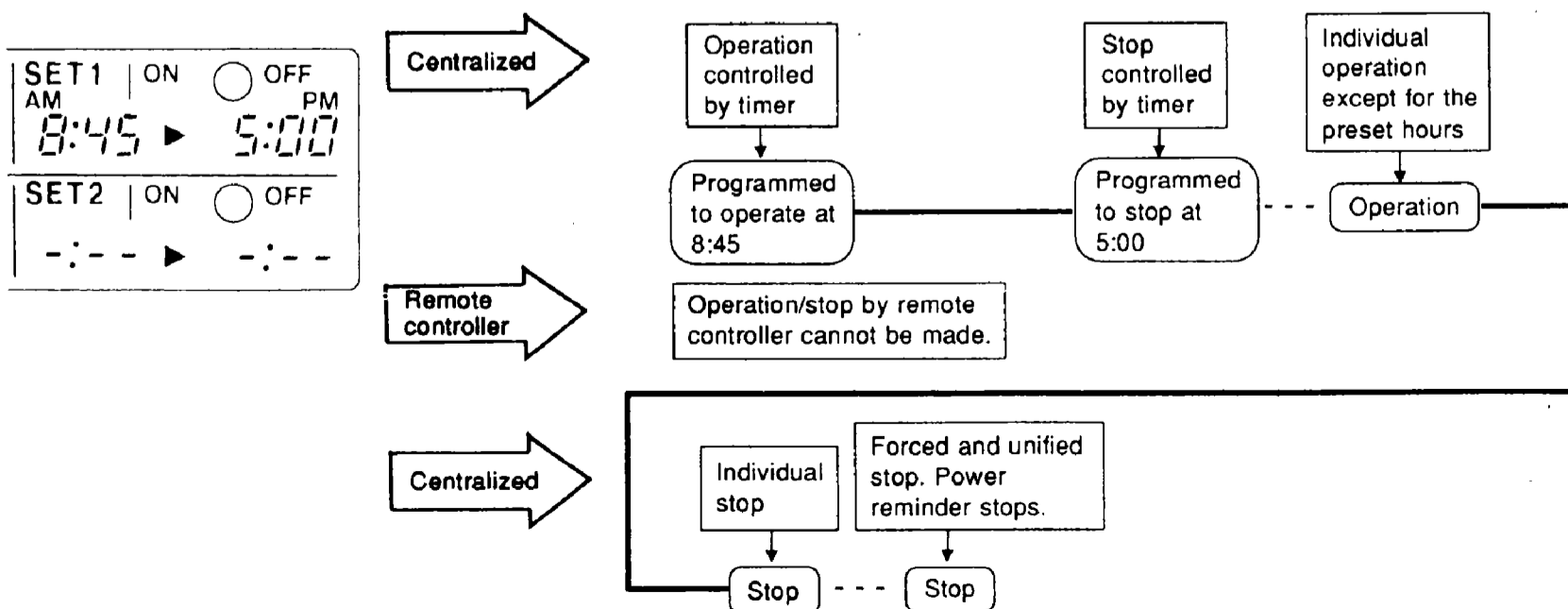


## EXAMPLE OF OPERATION SCHEDULE

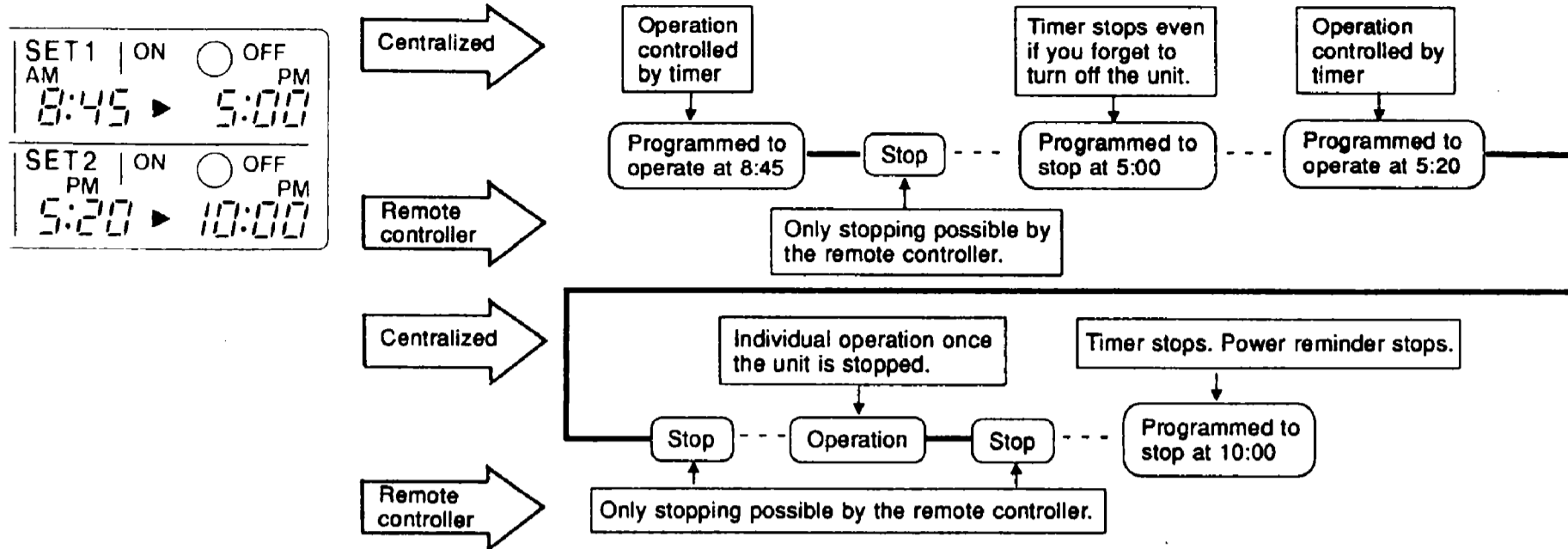
Operation schedule is possible only in conjunction with the schedule timer (optional accessory).

### Liquid crystal display of schedule timer

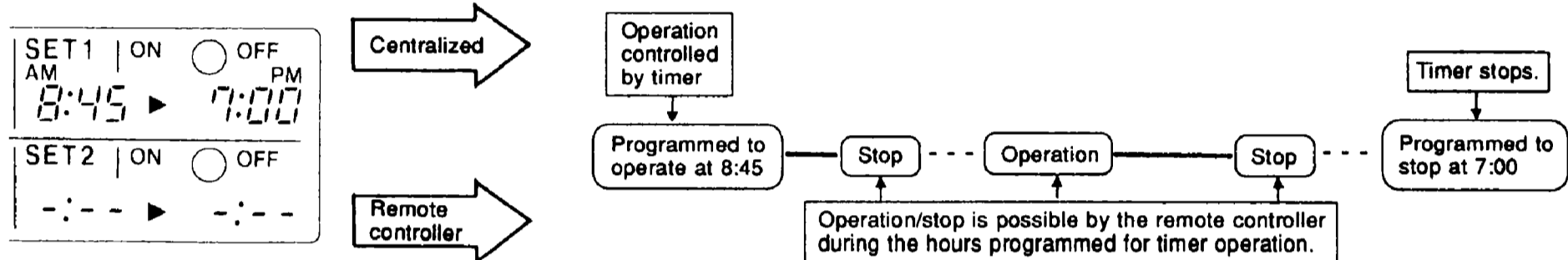
ON/OFF control impossible by remote controller



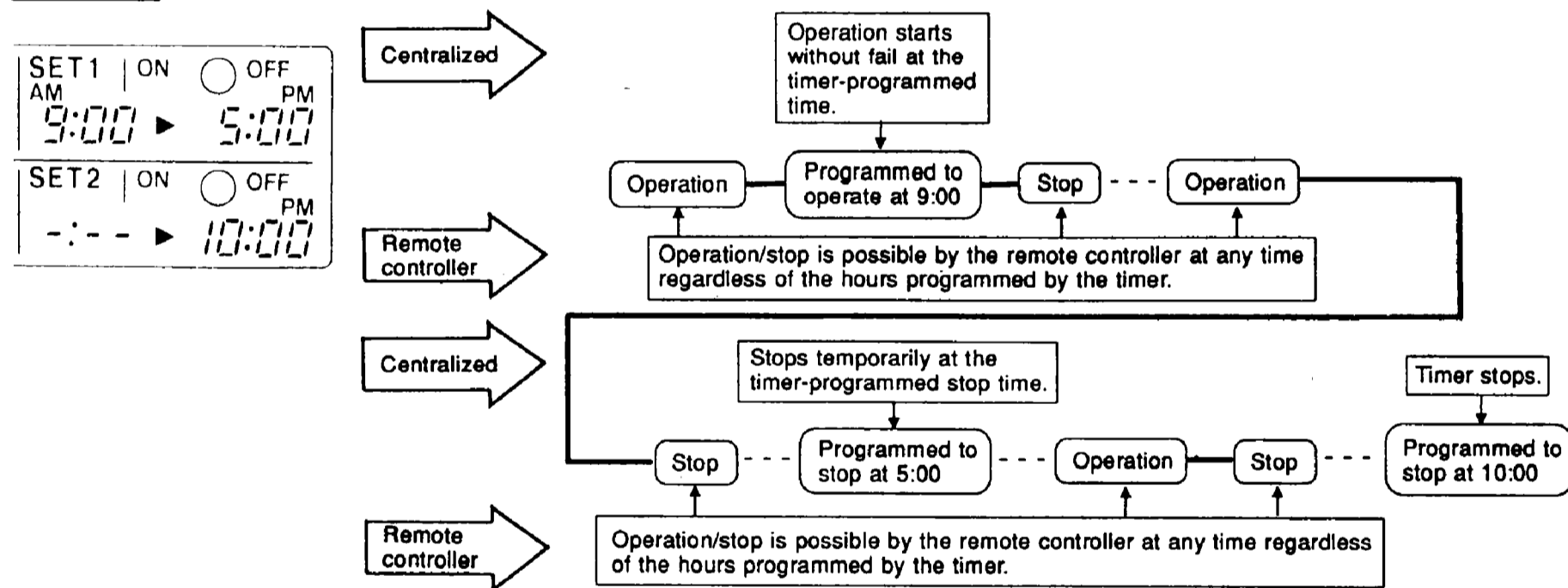
### Only OFF control possible by remote controller



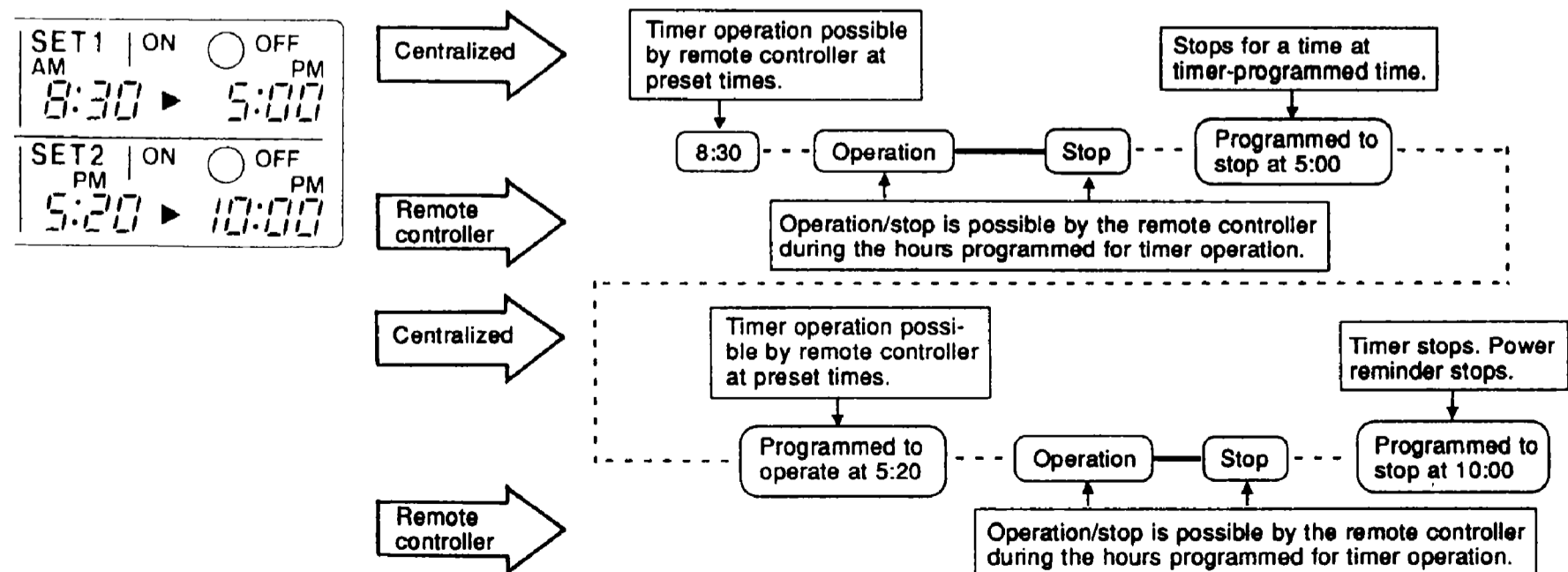
### Centralized



### Individual



### Timer operation possible by remote controller



- Air conditioner now operating.
- - - Air conditioner now stopping.
- ◻ Command by central remote controller
- ◻ Command by remote controller

## SETTING OPERATION MODE (Fig. 5)

- The Zone consists of the following two cases.

### A. Zone without display “”

The group with master remote controller setting exists in this zone.

Setting the master remote controller enables cool/heat selection.

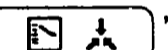
Operations other than cool/heat operations can also be set for some operations. For further details, see the list on the right.

### B. Zone with display “”

No group with master remote controller setting exists in this zone.

The cool/heat selection is not available because the master remote controller has not been set.

Some operations other than cool/heat operations can be set. For further details, see the list in the right.









See page 81 if the display “” is flashing.









**1** Press the OPERATION MODE SELECTOR BUTTON. Each time you press this button, the display rotates as shown on the right list.

#### NOTES

- During cool/heat operation, this central remote controller enables FAN operation for each zone even without setting the master remote controller. Meanwhile, ventilation, ventilation/cleaning, etc. are available, if HRV etc. are connected with this unit in the zone. See the operation manual provided with the each unit.
- When the indoor unit is in heat operation, change the setting to FAN operation through the central remote controller; then, you can switch the fan speed to the extremely low fan speed. Warm air may blow if any other indoor unit belonging to the same system is in heat operation.
- The indoor fan stops during defrost/hot start.
- DRY cannot be set from the central remote controller.

#### • List of setting operation

Display	A: Zones not displayed	
	Setting	Contents of setting
	×	
	○	To be set by zone
	○ * 1	To be set by zone
	○	To be set by zone
	○	To be set by zone
	○ * 1	To be set by zone
	○ * 1	To be set by zone
	○	Select this display if you don't wish to set by zone.

Display	B: Zones displayed	
	Setting	Contents of setting
	○	* 2
	○	To be set by zone
	×	
	×	
	×	
	○ * 1	To be set by zone
	○ * 1	
	○	Select this display if you don't wish to set by zone.

Note) In the above list, “○” refers to the acceptable setting, while “×” refers to the not acceptable setting.

In the meanwhile, \*1 and \*2 refer to the followings.

\*1: Setting may not be acceptable depending on the type of indoor unit with which this unit is connected.

\*2: The group on FAN operation in the zone performs the temperature control operation (cool/heat) under the outdoor refrigerant system.

## TEMPERATURE SETTING (Fig. 6)

**1** Press the **TEMPERATURE SETTING BUTTON**.

Each time you press the “▲”, the temperature rises by 1°C.

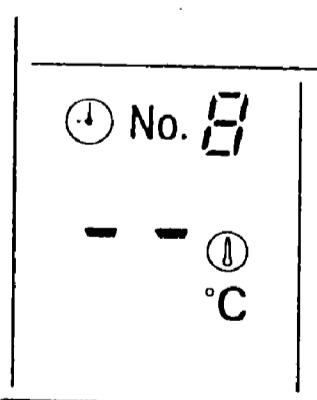
Each time you press the “▼”, the temperature falls by 1°C.

If you don't wish to set the temperature in a unified manner in the zone, set the temperature to “--”.

### NOTES

- The setting temperature refers to that of the temperature sensing part. (It may differ from the room temperature.)
- The proper setting temperature is 26 – 28° C during cooling operation, and 18 – 23° C during heating operation.
- The setting temperature is not displayed in the FAN mode and Ventilation/Cleaning mode. The set temperature is not displayed either if HRV etc. form a zone without an air conditioner.

If you wish to set the temperature to “--”



(Example)  
In case where the range of temperature to be set is 16 – 32°C  
Press the “▼” when the display shows 16°C. The display “--” appears.  
Press the “▲” when the display shows 32°C. The display “--” appears.

Set the temperature at the point 1°C higher than the upper limit and 1°C lower than the lower limit of the range subject to setting, respectively.

## GROUP MONITORING (Fig. 7)

Utilize the group monitor function in each of the following cases:

1. Check the malfunction code. (See the next page.)
2. Check the group that requires cleaning of the air filter and air cleaner element. (See page 82.)
3. Change the setting of the master remote controller. (See page 81.)
4. Check the group(s) sharing the same outdoor unit. Or, check the particular group(s) with the master remote controller setting. (See page 82.)
5. Check the conditions of other individual groups.

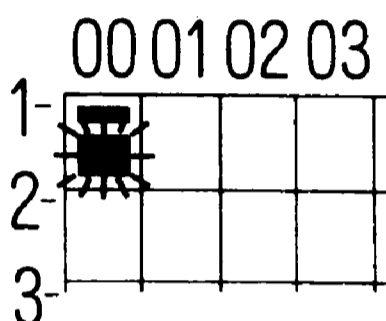
**1** Press the **ZONE/GROUP CHANGEOVER BUTTON** on the display of zoning, and the display “group” appears.

Unless operated from within one minute from when the display of zoning appears, the display will automatically revert back to the “group” display.

**2** Press the **ADVANCE/BACKWARD BUTTON** to set the group No. Then, operation monitor display “■” of group No. lights up in the displayed zone; then, the state of the above group(s) is displayed in the liquid crystal display.

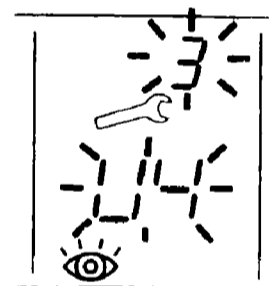
## ERROR DIAGNOSING FUNCTION (Fig. 8)

This central remote controller is provided with a diagnosing function, for when an indoor unit stops due to malfunction. In case of actuation of a safety device, disconnection in transmission wiring for control or failure of some parts, the operation lamp, inspection display and unit No. start to flash; then, the malfunction code is displayed. Check the contents of the display, and contact your DAIKIN dealer because the above signs can give you the idea on the trouble area.



The display "■" flashes under the group No. where the indoor unit that has stopped due to malfunction.

**1** Press the RETURN/ADVANCE BUTTON to call up the group that has stopped due to malfunction.



The unit No. that has stopped due to malfunction and the malfunction code flash are displayed. The display of control mode is replaced by that of the unit No.

## SETTING MASTER REMOTE CONTROLLER (Fig. 9)

You must set the master remote controller of the operation mode for one of the indoor units, if two or more such indoor units with the remote controller are connected with the outdoor unit where the operation modes such as cool/heat operation and FAN operation can be set by remote controller and central remote controller.

**1** • Check the particular group with the master remote controller setting for the refrigerant system you wish to reset. (See the right.)

• Call up the group without the display " " (See page 80.) Hold the OPERATION MODE SELECTOR BUTTON down for about four seconds while the above group is being called up. The display " " flashes on the liquid crystal display of the remote controller for all the groups sharing the same outdoor unit or BS unit.

When you turn on the power switch for the first time, the display " " flashes.

**2** Call up the desired group to set the master remote controller, and press the OPERATION MODE SELECTOR BUTTON. The master remote controller is set for this group, and the display " " goes out. The display " " appears for the other groups.

Setting is finished now.

• In case of operation switch  
Call up the zone including the group with the setting of master remote controller. (Zone without the display " ")  
Press the OPERATION MODE SELECTOR BUTTON several times, and switch to the desired operation mode.  
Each time you press it, the display is switched to " " " " " " and " " in sequence.

### NOTE

- Press the ZONE/GROUP CHANGE OVER BUTTON, and call up the display of zoning.
- However, the displays "A" " " and " " may appear in some zones, depending on the type of indoor unit with which they are connected.

## FUNCTION OF REFRIGERANT SYSTEM DISPLAY (Fig. 10)

The following information becomes available by utilizing this function.

- Indoor group connected with the same outdoor unit
- Indoor group with the master remote controller setting of the given refrigerant system

**1** Press the ZONE/GROUP CHANGEOVER BUTTON, and call up the display "group" if the display of zoning appears.

Unless operated from within one minute from when the display of zoning appears, the display will automatically revert back to the "group" display.

**2** Press the BUTTON FOR REFRIGERANT SYSTEM DISPLAY. The display "REF. CIRCUIT" appears.

**3** Press the ADVANCE/BACKWARD BUTTON to call up the group of which you wish to check the refrigerant system.

	00	01	02	03	04	05	06	07
1				■		■	■	■
2				■				
3				■	■			

The display "■" of all the groups sharing the same refrigerant system as the group on display flashes.

Then, the display

"■" of the particular group among them with the master remote controller setting flashes. Repeat the procedure 3 if you wish to check other refrigerant systems as well.

The above example shows that the groups 1-00, 1-03, 1-05, 1-06, 1-07, 2-03 and 2-04 share the same refrigerant system, and also that the master remote controller is provided with group 1-03.

**4** Press the BUTTON FOR REFRIGERANT SYSTEM DISPLAY again. The display "REF. CIRCUIT" goes out. The refrigerant system display

is finished now.

### NOTE

- Unless operated from within one minute from when the refrigerant system display, the display will automatically revert back to the "group" display.
- This function may not be available depending on the type of outdoor unit with which the unit is connected. In this case, the display "REF. CIRCUIT" flashes.

## DISPLAY OF TIME TO CLEAN (Fig. 11)

This central remote controller displays the time to clean the air filter or air cleaner element for each group or any given group by utilizing two types of signs. The display "⊗/⊕" tells the time to clean the air filter or the air cleaner element of some group.

**1** Press the ADVANCE/BACKWARD BUTTON, and search the groups displaying "⊗" or "⊕" (The group may be plural.)

Clean or change the air filter or air cleaner element.

For further details, see the operation manual attached to each indoor unit. (Clean or change the air filter or air cleaner element of all the groups displaying "⊗" or "⊕".)

**2** Press the FILTER SIGN RESET BUTTON, and the display "⊗/⊕" disappears. (Including all the groups where the air filter has been cleaned.)

### NOTE

Be sure to check the display "⊗/⊕" has disappeared at this point. The appearance of the above display is a sign that the air filter or air cleaner element of some group still needs cleaning.

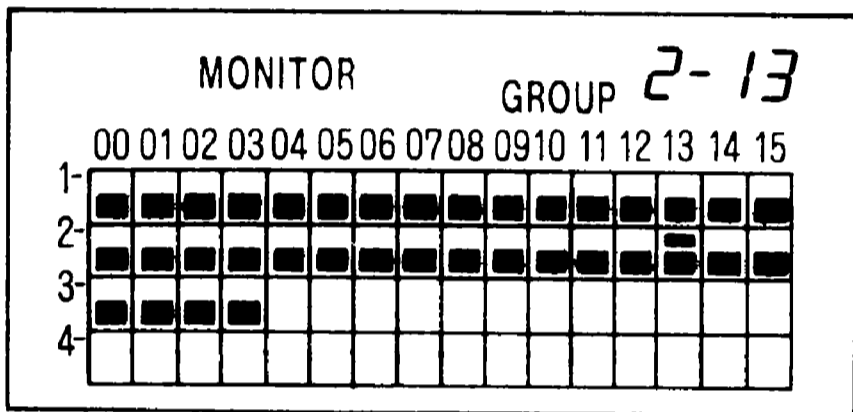
# UNIFIED OPERATION (Fig. 12)

Use this function when executing operation and stop of all the connected indoor units.



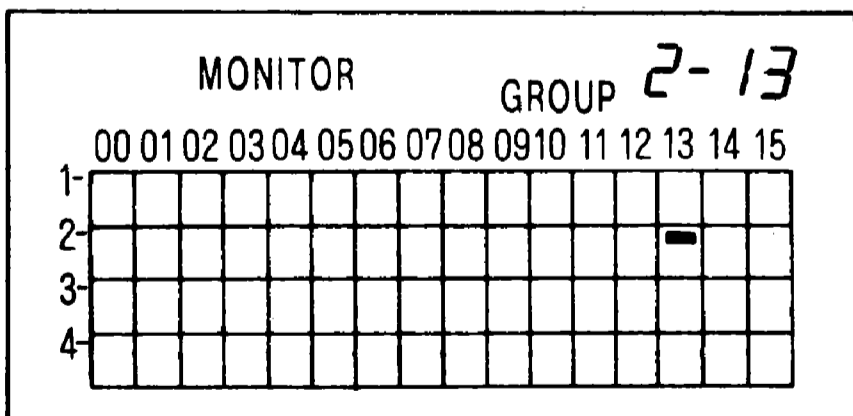
## A Unified operation

Press the **UNIFIED OPERATION BUTTON**. All the displays "■" of the group No. in operation light up at the same time, and all the groups start to operate at the same time.



## B Unified stop

Press the **UNIFIED STOP BUTTON**. The lights of every display "■" of group No. in operation go out at the same time; then, the lights of all the groups stop at the same time.



- When using the central remote controller in conjunction with other optional controllers for centralized control, the OPERATION LAMP on controllers which are not being used for operation may delay a few minutes before lighting or going out.

There is nothing wrong with the equipment. The delay is due to signal exchange.

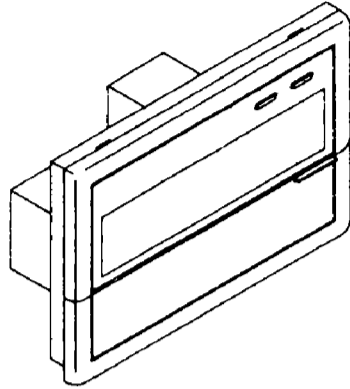


# ★ Installation

## 1 COMPONENTS

Check the following components are included in this optional accessory before installation.

Body



Installation screw (M4 x 16)	4
Operation manual	1
Installation manual	1
Installation table	1
Zone registration name plate	1

For installation, a steel electrical box to be embedded is necessary.

## 2 SYSTEM CONFIGURATION

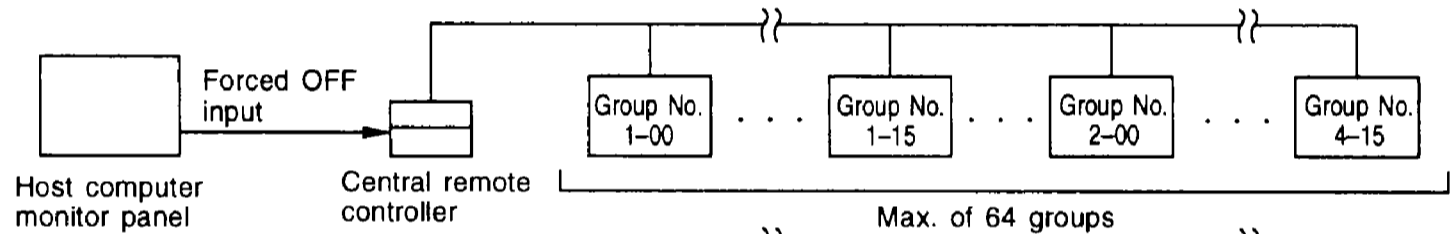
With the central remote controller, unified operation/stop is possible with up to a maximum 64 groups of indoor units. When using 2 central remote controllers, unified operation is possible with up to a maximum 128 groups.

With this optional accessory, setting of control modes including operation, stop, operation controlled by timer, and ON/OFF control possible/impossible by remote controller can be set individually by zones while it enables to control and display the operation state such as set temperature.

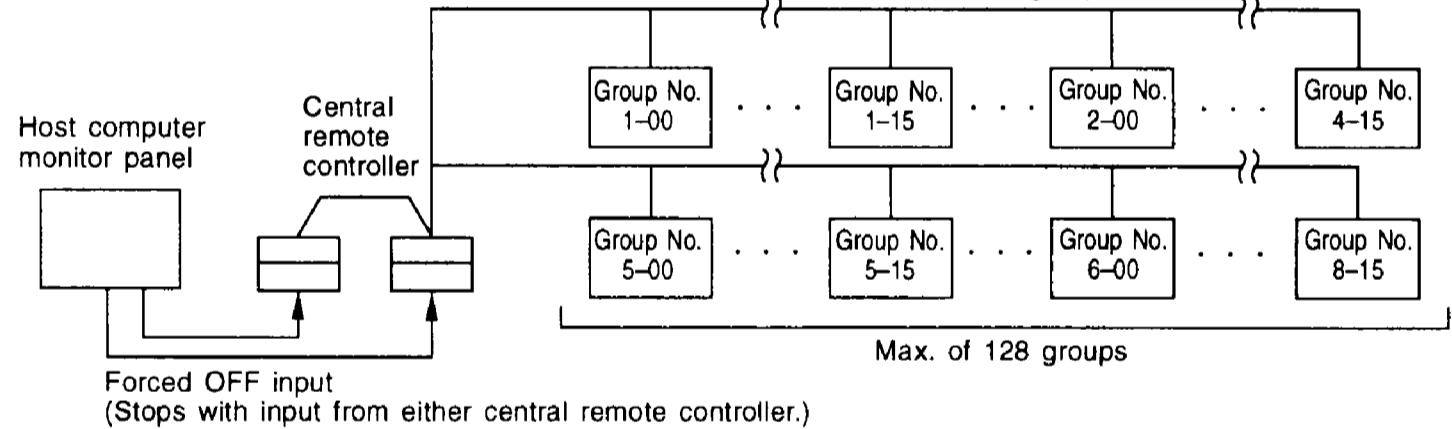
This optional accessory displays the operation state including operation mode and set temperature by each group.

It can be connected with the external key system, host computer monitor panel, etc., through forced OFF input (no-voltage normally open contactor).

- When using 1 central remote controller



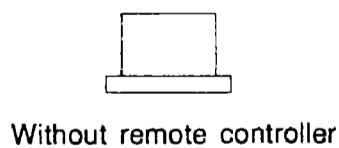
- When using 2 central remote controllers



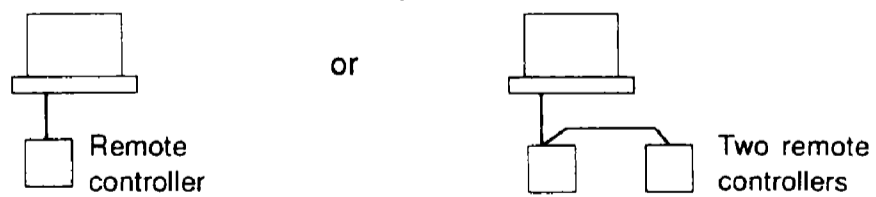
This optional accessory can not be used in conjunction with wiring adaptor for electrical appendices (optional accessory).

The groups of indoor units are as follows:

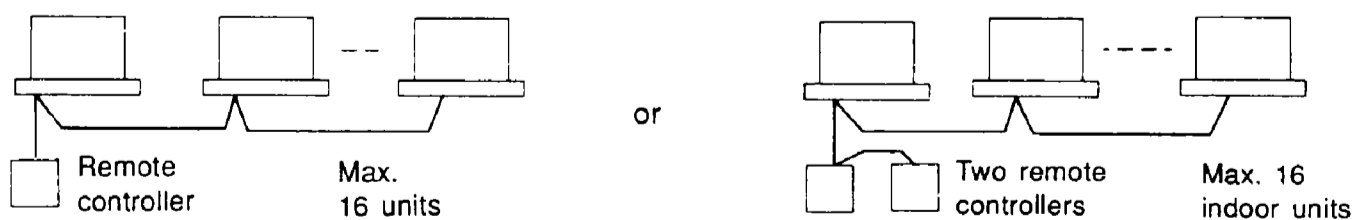
- ① One indoor unit without remote controller



- ② One indoor unit controlled by one or two remote controllers



- ③ A maximum of 16 indoor units controlled in groups by one or two remote controllers



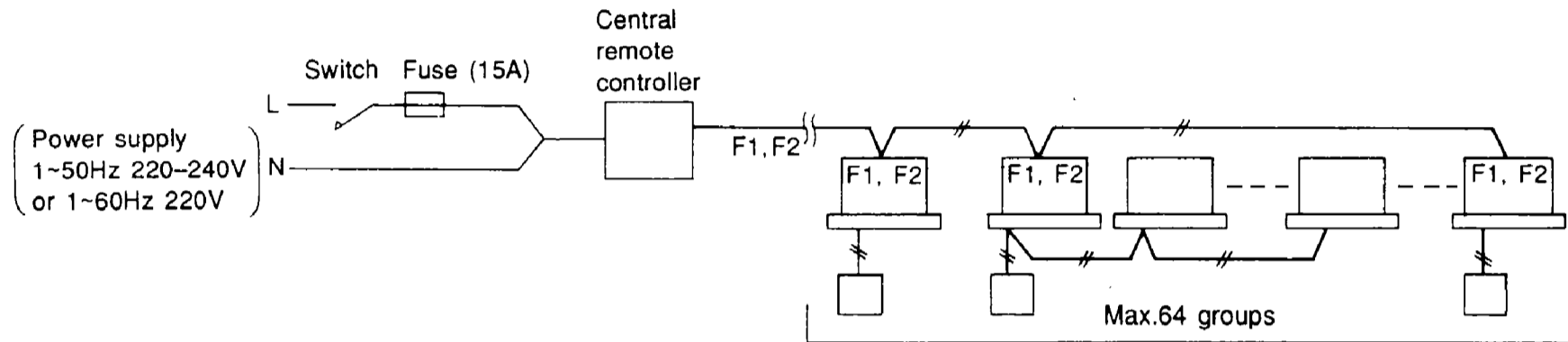
A zone consists of more than one group. The setting is the same within a zone.

### 3 ELECTRIC WIRING

#### GENERAL INSTRUCTIONS

- All wiring, components and materials to be procured on the site must comply with the applicable local and national codes.
- Use copper conductors only.
- All field wiring and components must be provided by licensed electrician.
- Unit shall be grounded in compliance with the applicable local and national codes.
- Fit the power supply wiring with a fuse and a switch.
- After wiring work, check power to the equipment shuts OFF when switch is shut OFF.

#### WIRING OUTLINE



#### Wiring specification

	Type	Size
Power supply wiring	H05VV-U3G	(NOTE 1)
Transmission wiring	Sheathed wire (2 wire) (NOTE 2)	0.75 - 1.25 mm <sup>2</sup>

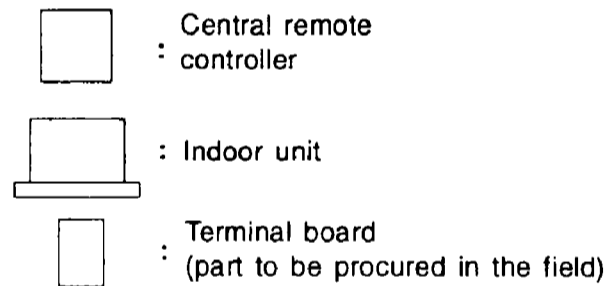
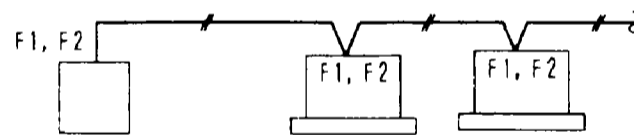
- NOTES) 1. The size of power supply wiring must comply with the applicable national and local codes.  
 2. Allowable length of transmission wiring is as follows.
- Max. 1000m (Total wiring length: 2000m)

Connect the wiring between indoor and outdoor units, indoor/outdoor units and power supply, and indoor units and remote controllers.

For details, refer to the installation manuals of indoor and outdoor units.

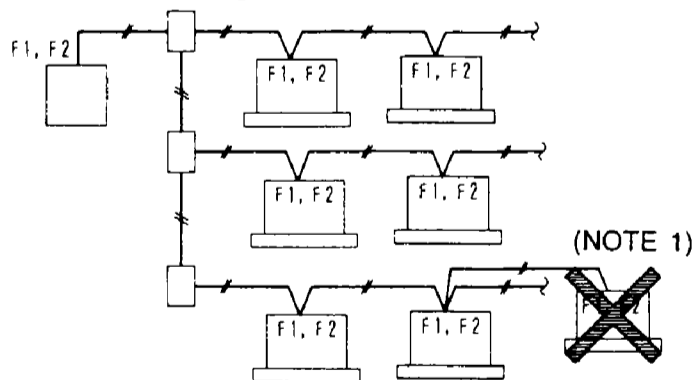
#### EXAMPLES OF WIRING FOR TRANSMISSION

##### ① Series wiring



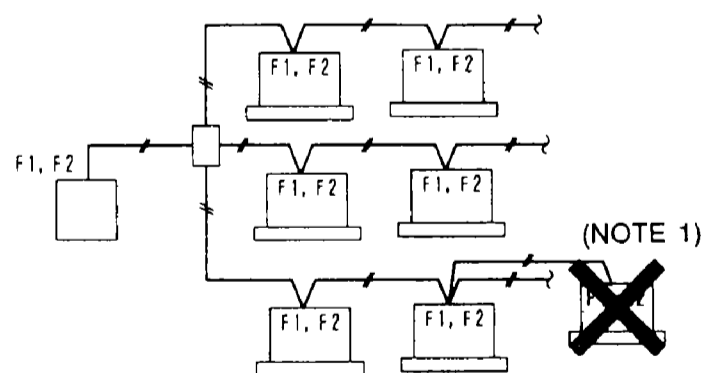
##### ② Bus type wiring (Can be branched up to 16 branchings)

Example of 3 branchings



##### ③ Star type wiring (Can be branched up to 16 branchings)

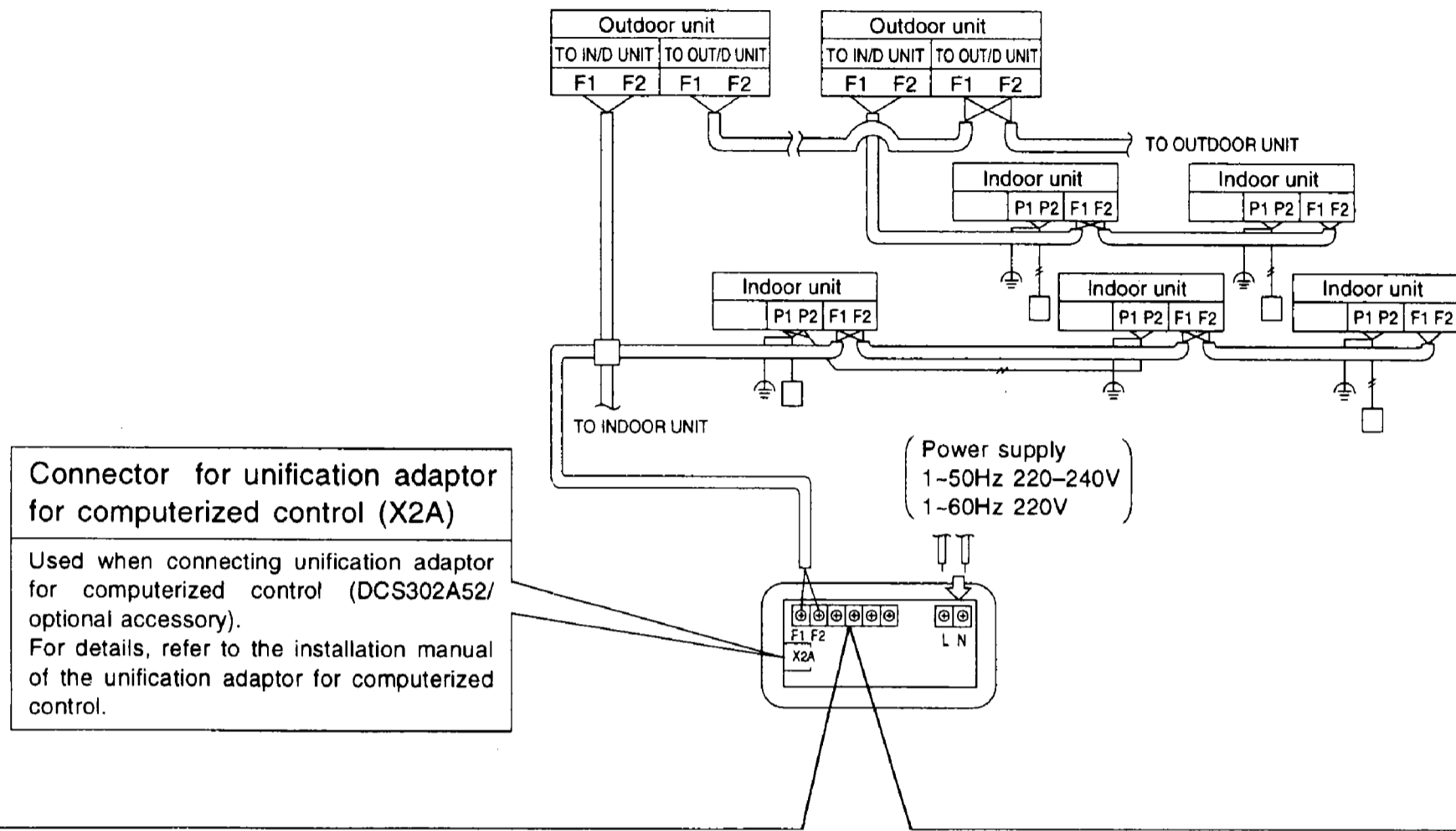
Example of 3 branchings



NOTES) 1. No branching is allowed after branching.

2. Use a relay terminal board (part to be procured in the field) to branch more than 3 control wirings from the same terminal board.

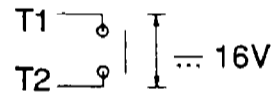
## WIRING TO THE INDOOR UNIT AND OUTDOOR UNIT



### CONTROL TERMINAL STRIP

- \* 1 For connecting indoor unit (F1, F2)
- \* 2 Forced OFF input (T1, T2)

While the forced OFF input (no voltage contactor, for micro current) is ON (energized), all the connected indoor units are stopped and can not be operated. Use only contactors which guarantee the minimum applicable load  $\approx$  16V, 10mA.

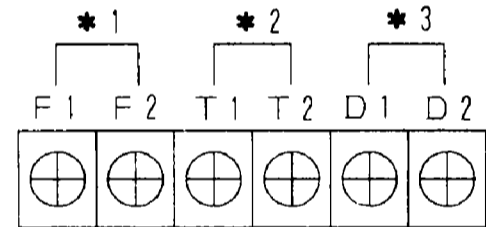


NOTE) Use instantaneous contactor of over 200msec. energizing time, when necessary.

- \* 3 For schedule timer (D1, D2)

Power can be supplied to the schedule timer (DST301B61) separately sold. For details, refer to the installation manual of the schedule timer.

Wire \* 2 and \* 3 only when necessary.



#### (NOTE)

Do not connect the power supply wiring (220 to 240V) to the control terminal strip. If connected by mistake, it may damage or burn electrical parts of optional controllers for centralized control and indoor unit. It may result in serious danger. Be sure to check wirings before turning the power ON.

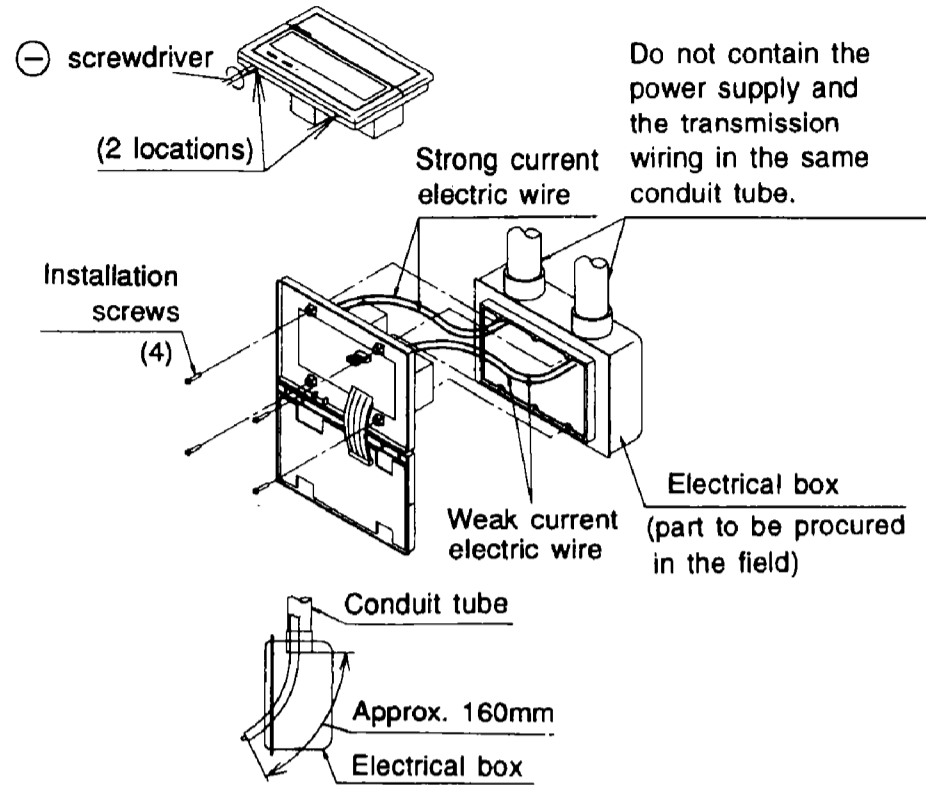
## 4 INSTALLATION

- ① Open the upper part of remote controller.  
Insert a ⊖ screwdriver (2 locations) into the recess between the upper part and the lower part of remote controller and twist the screwdriver lightly.

PC board is attached with both the upper and lower part of remote controller. Do not damage the board with the screwdriver.

- ② Open the upper part of remote controller and install the Electrical box (part to be procured in the field) with the attached installation screws (M4 x 16).

NOTE) Suitable length of the electric wire is about 160mm. If it is difficult to contain a long wiring, strip the sheathed part of the wiring.



# 5 INITIAL SETTING

Setting ① through ③ are initialized when power is turned ON, therefore complete settings BEFORE activating the power.

- ① Connector for setting master controller (X1A) (Provided with connector at factory set)
  - When using only 1 central remote controller, do not disconnect the connector for setting master controller. (Use the unit with the connector in the state in which it was delivered.)
  - When using multiple central remote controllers, or using the central remote controller in conjunction with the optional controllers for centralized control, makes settings as indicated in the below table.

Pattern of connection of optional controllers for centralized control			Connector for setting master controller (X1A) Setting		
Central remote controller	Unified ON/OFF controller	Schedule timer	Central remote controller	Unified ON/OFF controller	Schedule timer
1 to 4	1 to 16	1	Set one to "Used" and all the rest to "Not used".	Set all to "Not used".	"Not used"
		1			"Not used"
		1			"Not used"

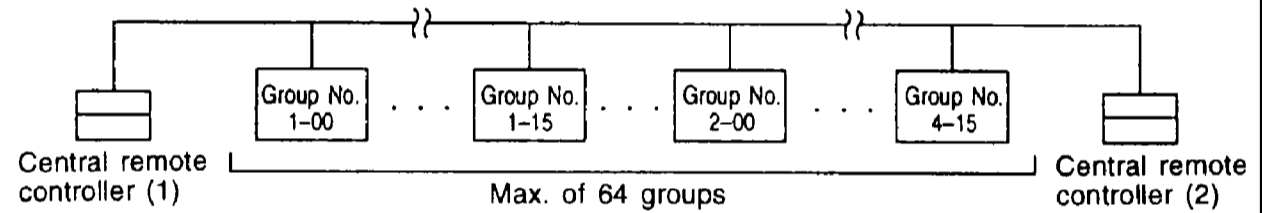
(Remove this connector when using this controller in conjunction with power consumption counting unit, parallel interface, and data station.)

- ② Address setting  
Two central remote controllers can be used as shown in **② SYSTEM CONFIGURATION**, to control anywhere up to a max. 128 groups of indoor units. In this case, group address must be set. This is done with the switch for setting each address (SS3).

SS3 setting	Indoor unit address			
<table border="1"> <tr><td>SETTING EACH ADDRESS</td></tr> <tr><td>5-00 ~ 8-15</td></tr> <tr><td>1-00 ~ 4-15</td></tr> </table>	SETTING EACH ADDRESS	5-00 ~ 8-15	1-00 ~ 4-15	To control indoor units from group Nos. 1-00 through 4-15 (Factory set)
SETTING EACH ADDRESS				
5-00 ~ 8-15				
1-00 ~ 4-15				

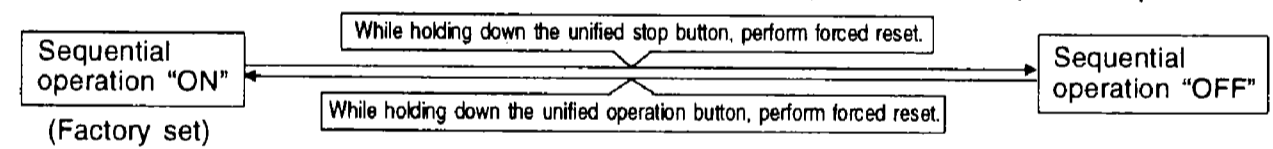
SS3 setting	Indoor unit address			
<table border="1"> <tr><td>SETTING EACH ADDRESS</td></tr> <tr><td>5-00 ~ 8-15</td></tr> <tr><td>1-00 ~ 4-15</td></tr> </table>	SETTING EACH ADDRESS	5-00 ~ 8-15	1-00 ~ 4-15	To control indoor units from group Nos. 5-00 through 8-15
SETTING EACH ADDRESS				
5-00 ~ 8-15				
1-00 ~ 4-15				

- ③ MAIN/SUB changeover switch setting  
With two central remote controllers, centralized control (indoor units) is possible from different locations. In this kind of set-up, it is necessary to set the MAIN/SUB changeover switch.



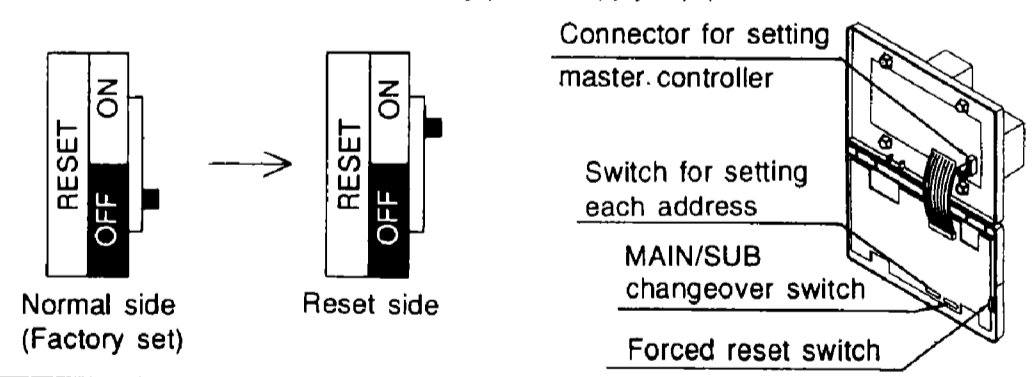
One of the two central remote controllers (1)•(2) is set to "MAIN" while the other is set to "SUB".

- ④ Setting of the sequential operation function  
The central remote controller is equipped with a sequential operation function that sequentially turns indoor units on in 2-second intervals during unified operation. (Sequential operation is factory set to "ON.") To switch sequential operation ON or OFF, set as follows.



NOTE: The sequential operation function is designed to reduce the load on the power supply equipment, but does not guarantee that compressors will not be started simultaneously. You cannot therefore count on a capacity reduction effect by power supply equipment breaker selection.

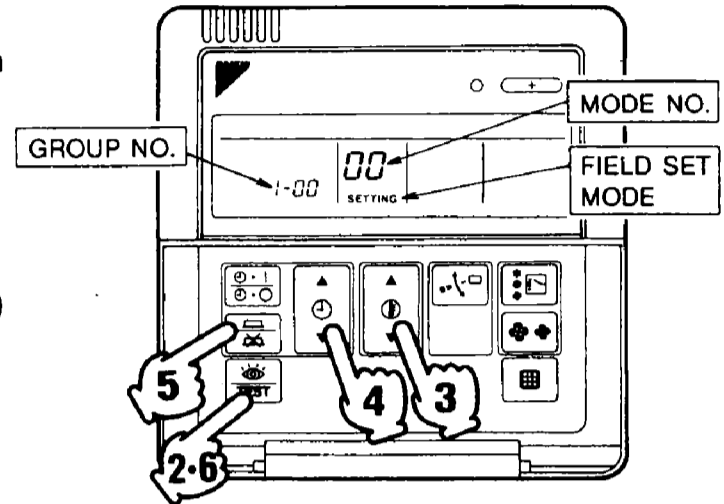
- ⑤ Forced reset switch  
When changing the setting of the connector for setting master controller, etc., you can reset simply by setting it to the reset side once and returning to the normal side, without turning the power OFF. (For normal operation, set the switch to the normal side.)



## 6 SETTING GROUP NO. FOR CENTRALIZED CONTROL

Set the group number of each group of the indoor unit from the remote controller. (In case of no remote controller, also connect the remote controller and set the group No. Then, remove the remote controller.)

- ① Turn ON the power of the indoor unit and central remote controller.  
(Unless the power is ON, no setting can be made.)  
Check that the installation and electrical wiring are correct before turning the power supply ON.  
(When the power supply is turned ON, all LCD appear once and the unit may not accept the operation for about one minute with the display of "88".)
- ② While in the normal mode, hold down the "TEST" button for a minimum of 4 seconds.  
The remote controller will enter the FIELD SET MODE.
- ③ Select the MODE No. "00" with the "MODE NO." button.
- ④ Use the "GROUP NO." button to select the group No. for each group.  
(Group numbers increase in the order of 1-00, 1-01, ... 1-15, 2-00, ... 8-15.)
- ⑤ Press "OK" to set the selected group No.
- ⑥ Press "TEST" to return to the NORMAL MODE.



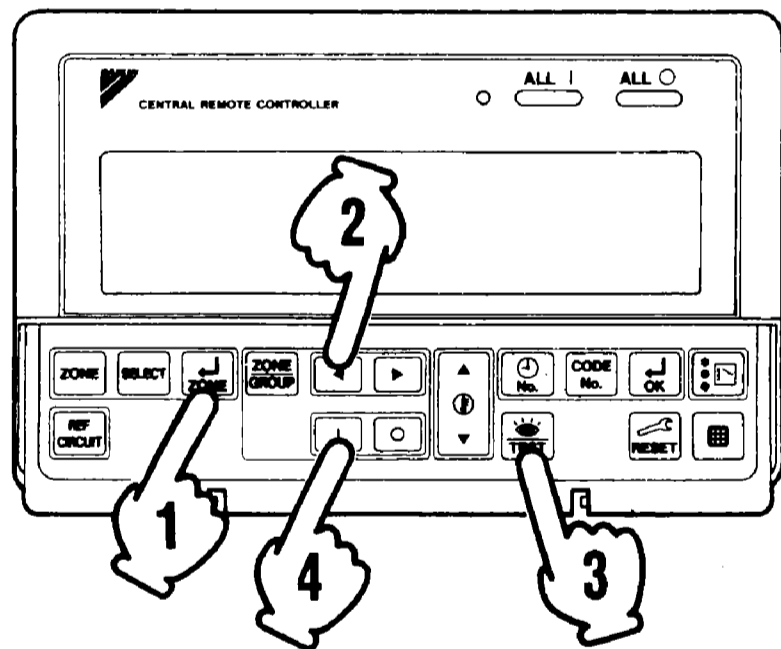
- NOTES) • For simplified remote controller, see the installation table.  
• For setting group No. of HRV and wiring adaptor for other air conditioners, etc., refer to the operation manual attached.

**NOTICE** Enter the group No. and installation place of the indoor unit into the attached installation table. Be sure to keep the installation table with the operation manual for maintenance.

## 7 TEST OPERATION (Complete the test operation before setting zones.)

Before starting test operation, check that the power is supplied to the indoor and outdoor units, and central remote controller.

- ① Select the display "group."  
Press "ZONE GROUP" button to display "group."
- ② Select the group to be tested.  
Select the group No. with "◀" "▶" button.
- ③ Press "TEST" button to select the test operation mode.  
"TEST" is displayed.  
"HOST" is displayed on the remote controller.
- ④ Press "I" button within 10 seconds after entering into the test operation mode.  
Operate the unit for 30 minutes.  
When pressing the "O" button, the unit stops operating.  
If the operation lamp flashes, it indicates a malfunction.  
Call the group of flashing display, confirm malfunction code, and check the source of malfunction.  
(For contents of malfunction codes, refer to the "CAUTION FOR SERVICING" attached to the indoor unit.)



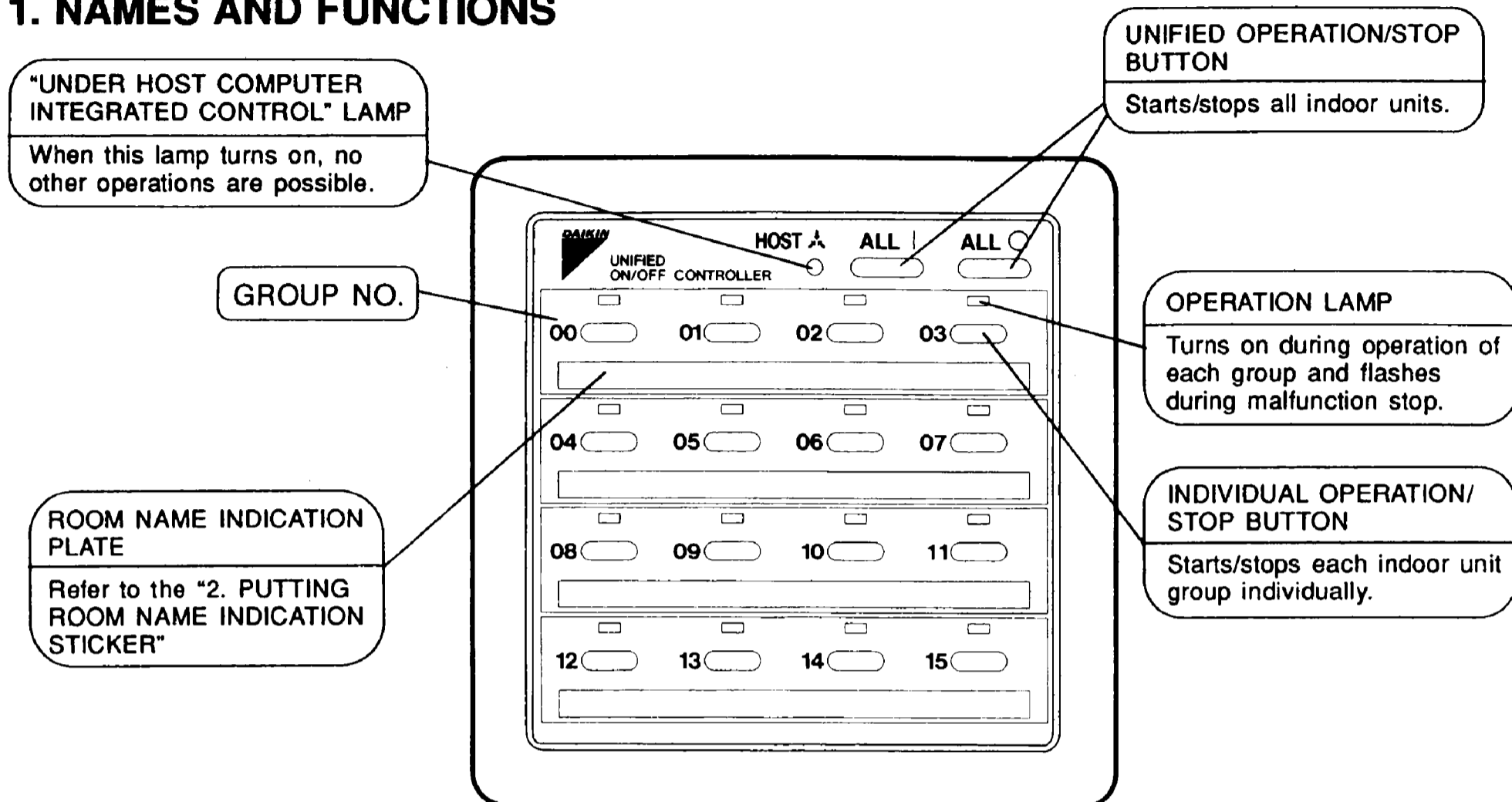
- NOTES
- For test operation, refer to the installation manual of the outdoor unit.
  - After turning the power supply ON, if the unit does not accept operation for two minutes or more with the display of "88", check the following points.
    - Check that setting of the connector for setting master controller is correct.
    - Check that the group No. for centralized control has been set.

### 3 Unified ON/OFF Controller

DCS301B61

★ Operation

#### 1. NAMES AND FUNCTIONS



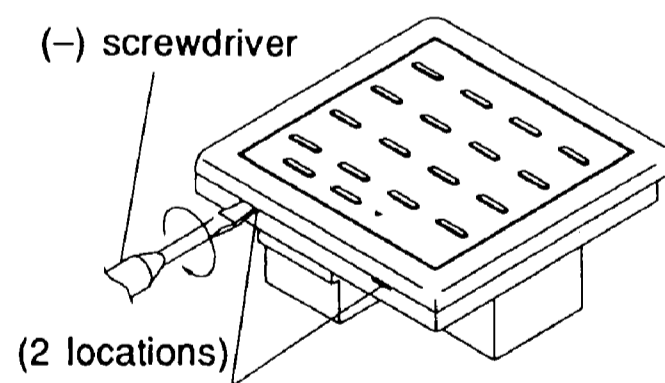
<< NOTE >>

- When using unified ON/OFF controller with other optional controllers for centralized control, "OPERATION LAMP" of the equipment which is not operated may turn on or off after several minutes.  
This state occurs due to signal communications and is not a failure.
- Do not open the upper part of remote controller except when rewriting the indication sticker or selecting control modes.

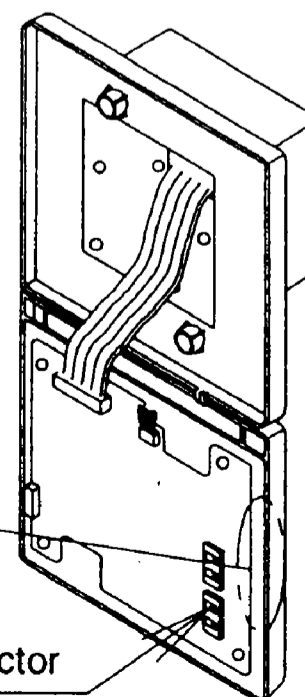
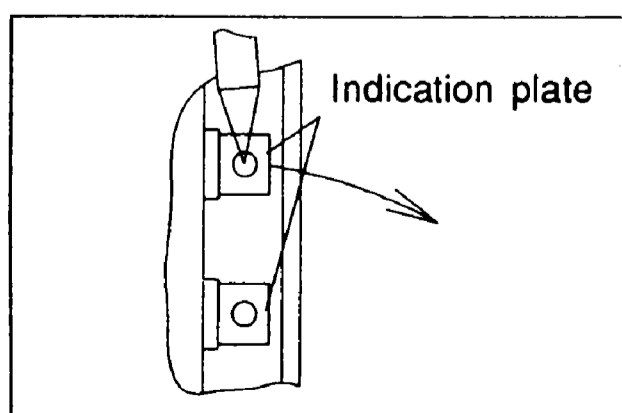
#### 2. PUTTING ROOM NAME INDICATION STICKER

- ① Open the upper part of remote controller.  
Insert a (-) screwdriver into the recess between the upper and lower part of remote controller (at 2 locations) and twist the screwdriver lightly.

PC board is attached both the upper and lower part of remote controller. Do not damage the board with the screwdriver.



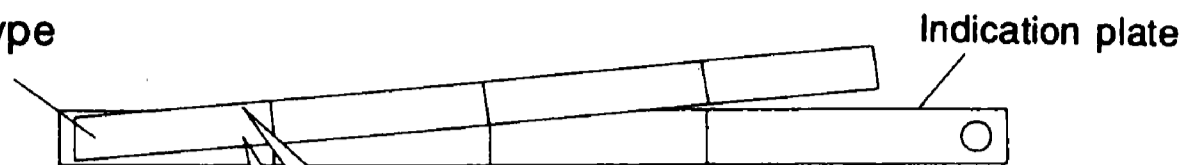
- ② Pull out the room name indication plate.  
Insert the point of a mechanical pencil etc, into the hole of the indication sticker to pull it out.



- ③ Put the attached indication sticker on the room name indication plate.

In case of serial type

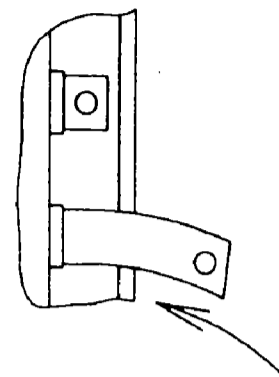
Indication sticker



Put the sticker aligning the lines of the sticker with those of the plate.

In case of individual type

Indication sticker



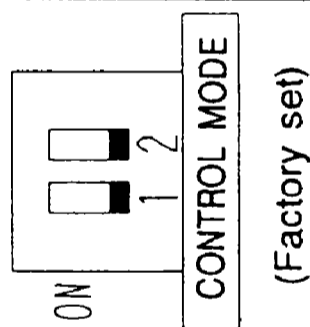
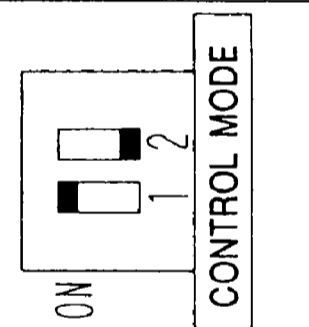
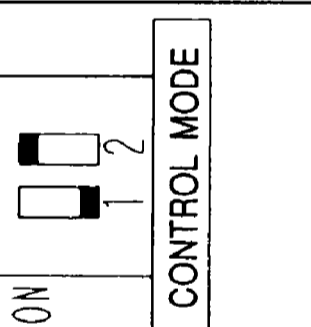
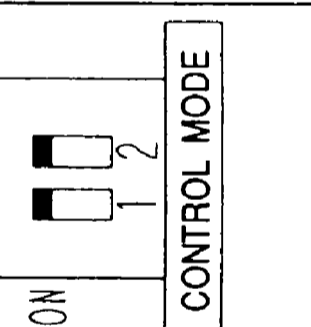
Put the sticker on the center of the frame.

Write the room name in the frame of the sticker with a ball point pen or a felt-tip pen (oil-base).

- ④ Reinstall the plate as it were, with checking the correct direction.  
 ⑤ Close the upper part of remote controller.

### 3. SELECTING CONTROL MODES

The following four patterns of control mode can be set.

Control mode	Individual	Centralized	Timer operation possible by remote controller	ON/OFF control impossible by remote controller
Content	Operation/stop is controlled by both unified ON/OFF controller and remote controller.	After operated by unified ON/OFF controller, operation/stop is freely controlled by remote controller until stopped by unified ON/OFF controller.	When used in conjunction with schedule timer, operation/stop is controlled freely by remote controller during the set time but operation is not available when schedule timer is ON.	Operation/stop is controlled by unified ON/OFF controller only. Indoor units can not be operated/stopped by remote controller.
DS2 setting				

NOTE : • ■ indicates the position of switches.

- Set control modes before turning power supply on.
- When used in conjunction with central remote controller, the control modes of the central remote controller has the priority.

### 4. DISPLAY OF MALFUNCTION

Flashing of lamps indicates malfunctions. Contact your Daikin dealer.

When turning power supply on, all lamps may light and UNDER HOST COMPUTER INTEGRATED CONTROL lamp may flash and not accept the operation for about one minute. These conditions are not malfunctions.

States of lamps	Contents of malfunctions
Flashing of operation lamp	Indicates malfunctions in the indoor unit in the group where the operation lamp is flashing.
Flashing of UNDER HOST COMPUTER INTEGRATED CONTROL lamp	Indicates malfunctions in optional controllers for centralized control.

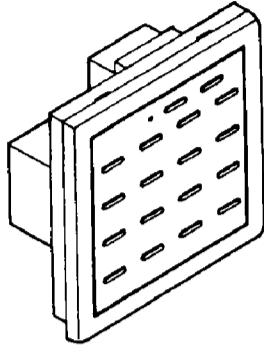


★ Installation

**1 COMPONENTS**

Check the following components are included in this optional accessory before installation.

Body



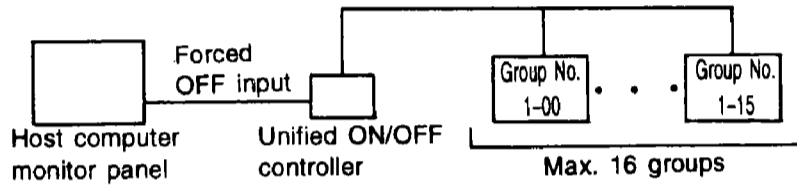
Installation screw (M4 x 16)	2
Operation manual	1
Installation manual	2
Installation table	2
Switch display sticker	1

For installation, a steel electrical box to be embedded is necessary.

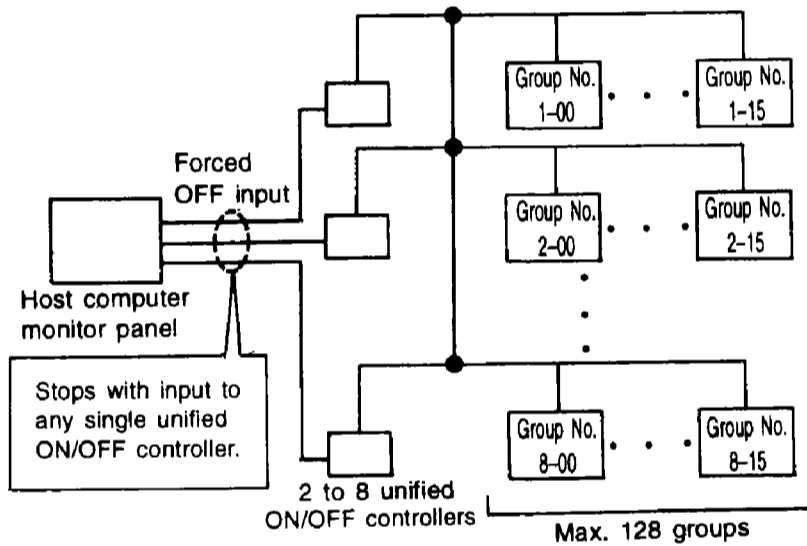
**2 SYSTEM CONFIGURATION**

This unified ON/OFF controller enables individual and unified operation/stop for a maximum of 16 groups of indoor units. With 2 to 8 unified ON/OFF controllers, individual and unified control is possible with up to a maximum 128 groups of indoor units.

- When using 1 unified ON/OFF controller



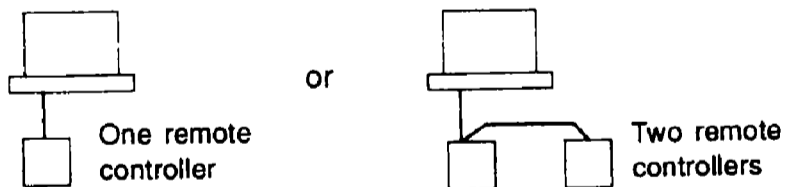
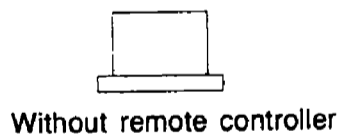
- When using 2 to 8 unified ON/OFF controllers



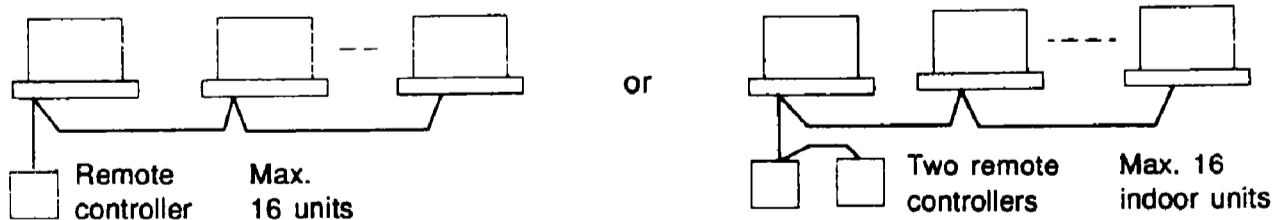
(This optional accessory can not be used in conjunction with wiring adaptor for electrical appendices (optional accessory).)

The groups of indoor units are as follows:

- ① One indoor unit without remote controller
- ② One indoor unit controlled by one or two remote controllers



- ③ A maximum of 16 indoor units controlled in groups by one or two remote controllers

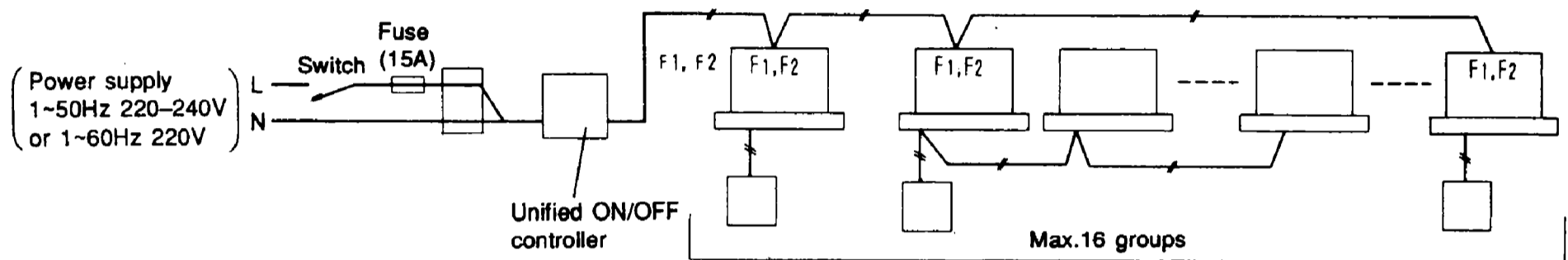


### 3 ELECTRIC WIRING

#### GENERAL INSTRUCTIONS

- All wiring, components and materials to be procured on the site must comply with the applicable local and national codes.
- Use copper conductors only.
- All field wiring and components must be provided by licensed electrician.
- Unit shall be grounded in compliance with the applicable local and national codes.
- Fit the power supply wiring with a fuse and a switch.
- After wiring work, check power to the equipment shuts OFF when switch is shut OFF.

#### WIRING OUTLINE



#### Wiring specification

	Type	Size
Power supply wiring	H05VV-U3G	(NOTE 1)
Transmission wiring	Sheathed wire (2 wire) (NOTE 2)	0.75 - 1.25 mm <sup>2</sup>

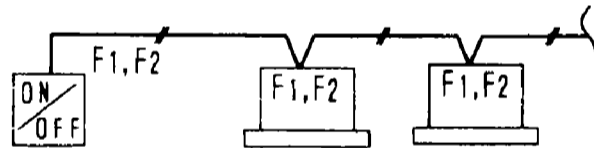
- NOTES) 1. The size of power supply wiring must comply with the applicable national and local codes.  
2. Allowable length of transmission wiring is as follows.  
Max. 1000m (Total wiring length: 2000m)

Connect the wiring between indoor and outdoor units, indoor/outdoor units and power supply, and indoor units and remote controllers.

For details, refer to the installation manuals of indoor and outdoor units.

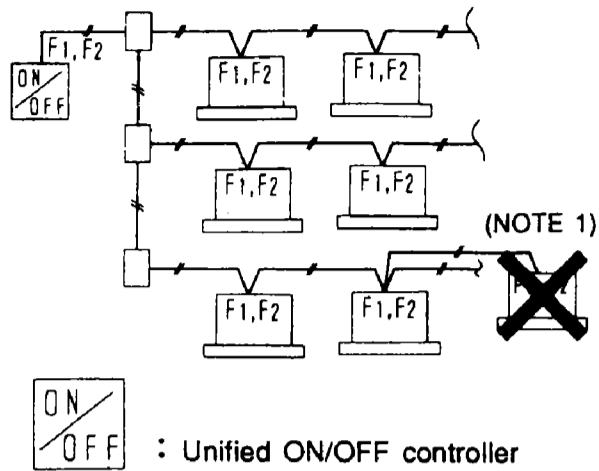
#### EXAMPLES OF WIRING FOR TRANSMISSION

##### ① Series wiring



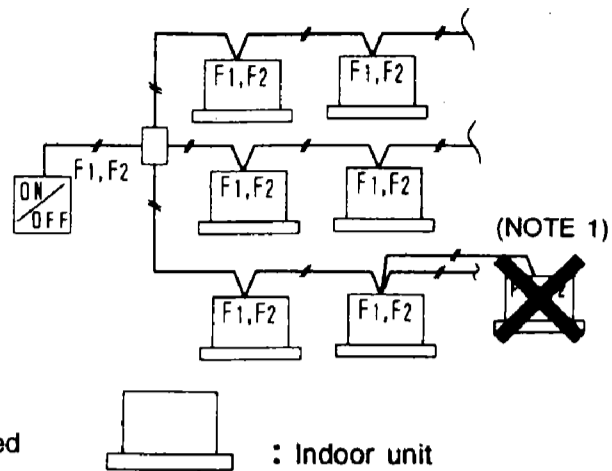
② Bus type wiring (Can be branched up to 16 branchings)

Example of 3 branchings



③ Star type wiring (Can be branched up to 16 branchings)

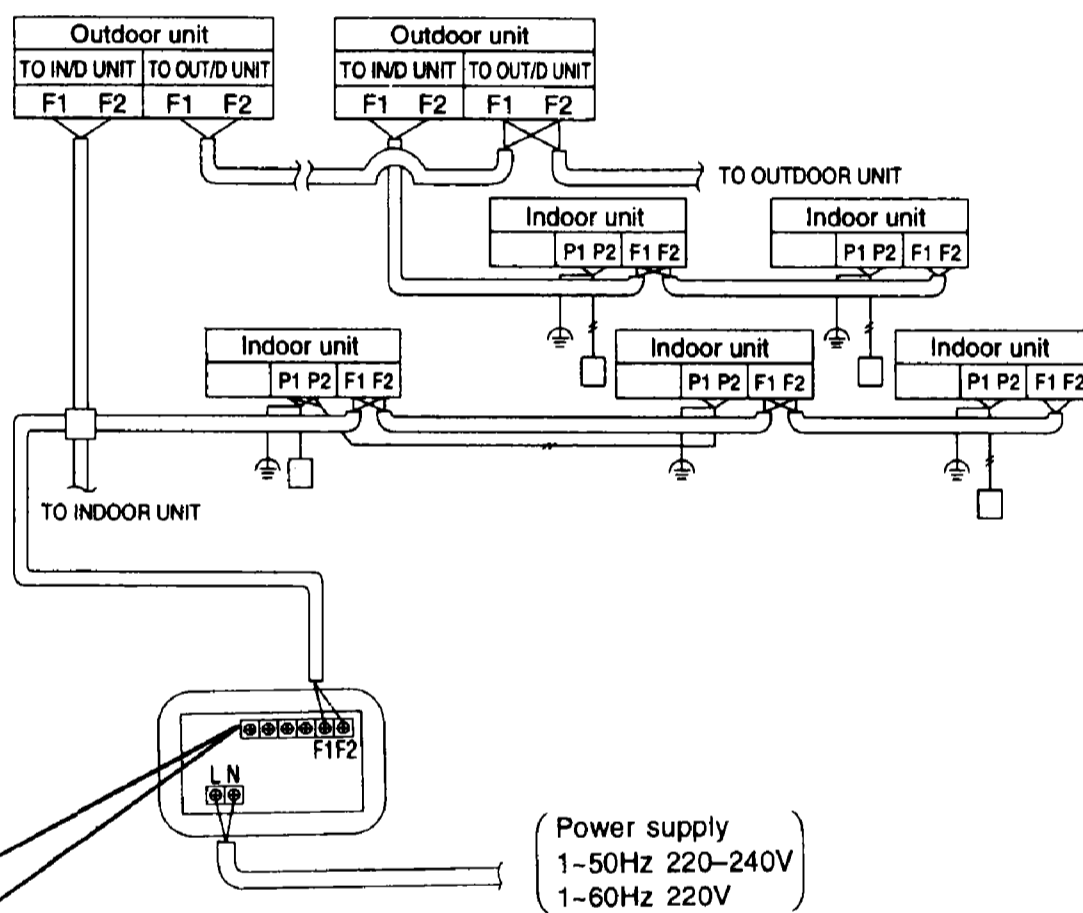
Example of 3 branchings



NOTES) 1. No branching is allowed after branching.

2. Use a relay terminal board (part to be procured in the field) to branch more than 3 control wirings from the same terminal board.

**WIRING TO THE INDOOR UNIT AND OUTDOOR UNIT**



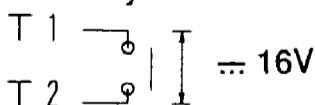
**CONTROL TERMINAL STRIP**

\* 1 For connecting indoor unit (F1, F2)

\* 2 Forced OFF input (T1, T2)

While the forced OFF input (no voltage contactor, for micro current) is ON (energized), all the connected indoor units are stopped and can not be operated.

Use only contactors which guarantee the minimum applicable load  $\approx 16V, 10mA$ .

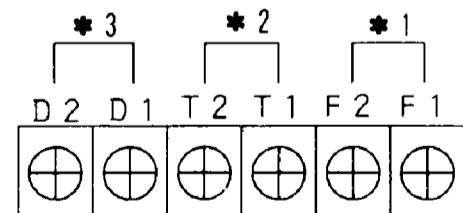


NOTE) Use instantaneous contactor of over 200msec. energizing time, when necessary.

\* 3 For schedule timer (D1, D2)

Power can be supplied to the schedule timer (DST301B61/optional accessory). For details, refer to the installation manual of the schedule timer.

Wire \* 2 and \* 3 only when necessary.



(NOTE)

Do not connect the power supply wiring (220 to 240V) to the control terminal strip. If connected by mistake, it may damage or burn electrical parts of optional controllers for centralized control and indoor unit. It may result in serious danger. Be sure to check wirings before turning the power ON.

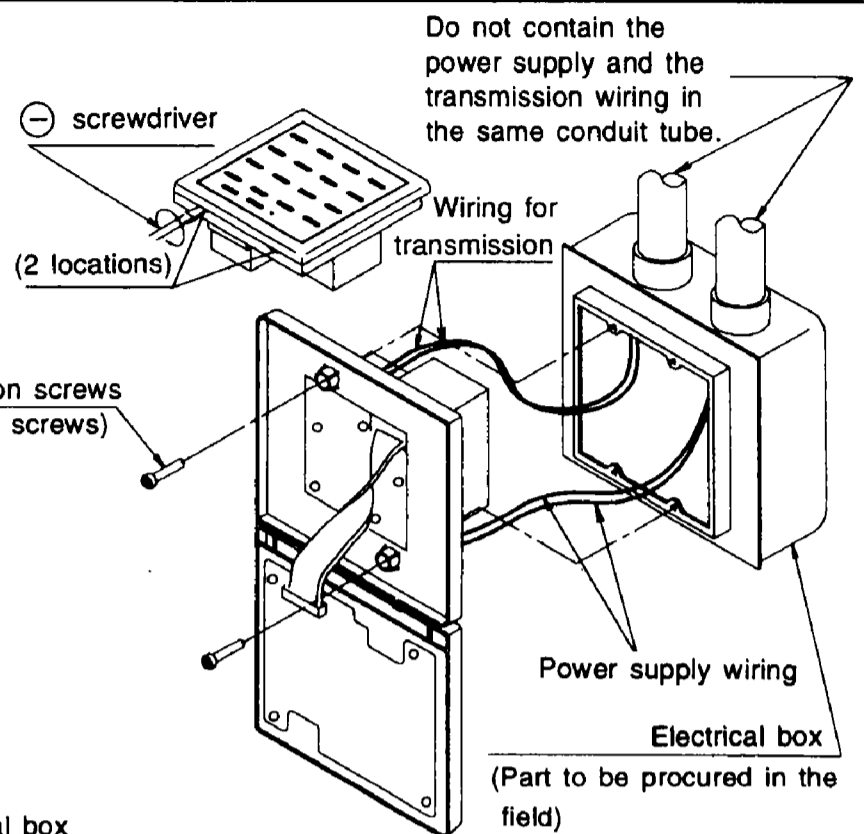
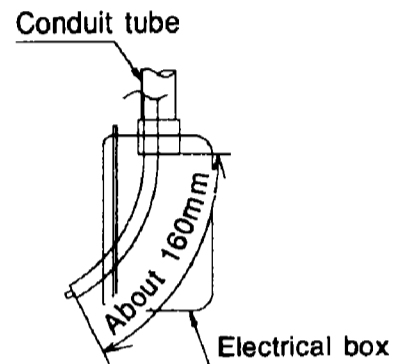
## 4 INSTALLATION

- ① Open the upper part of remote controller.  
Insert a ⊖ screwdriver (2 locations) into the recess between the upper part and the lower part of remote controller and twist the screwdriver lightly.

PC board is attached with both the upper and lower part of remote controller. Do not damage the board with the screwdriver.

- ② Open the upper part of remote controller and install the electrical box (part to be procured in the field) with the attached installation screws (M4 x 16).

NOTE) Suitable length of the electric wire is about 160mm from the inlet of the electrical box. If it is difficult to contain a long wiring, strip the sheathed part of the wiring.



## 5 INITIAL SETTING

Setting ① through ③ are initialized when power is turned ON, therefore complete settings BEFORE activating the power.

- ① Connector for setting master controller (X1A) (Provided with connector at factory set)
  - When using 1 unified ON/OFF controller, do not disconnect the connector for setting master controller. (Use the unit with the connector in the state in which it was delivered.)
  - When using multiple unified ON/OFF controllers, or using the unified ON/OFF controller in conjunction with other optional controllers for centralized control, makes settings as indicated in the right table.

Pattern of connection of optional controllers for centralized control			Connector for setting master controller (X1A) Settings		
Unified ON/OFF controller	Central remote controller	Schedule timer	Unified ON/OFF controller	Central remote controller	Schedule timer
1 to 16			Set one to "Used" and all the rest to "Not used".		
	1 to 4		Set all to "Not used".	(Note)	
		1	Set one to "Used" and all the rest to "Not used".		"Not used"
	1 to 4	1	Set all to "Not used".	(Note)	"Not used"

(Note) For instructions on how to set the connector for setting master controller on the central remote controller, see the installation manual provided with the central remote controller.

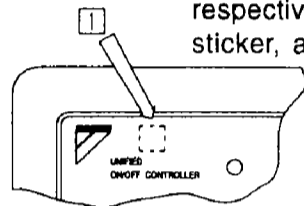
② Switch for setting each address (DS1)

These switches are used to set group control address.

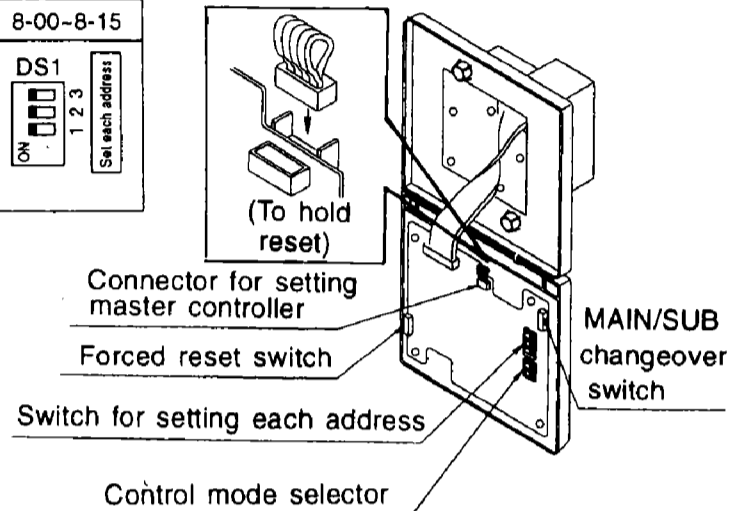
Groups Nos. 1-00 through 1-15 are grouped in the same control group when the unit is shipped from the factory.

Each Address	1-00-1-15	2-00-2-15	3-00-3-15	4-00-4-15	5-00-5-15	6-00-6-15	7-00-7-15	8-00-8-15
DS1 setting								
	(Factory setting)							

After setting, attach the number seal applicable to respective control range of the attached switch display sticker, as shown in the diagram below.

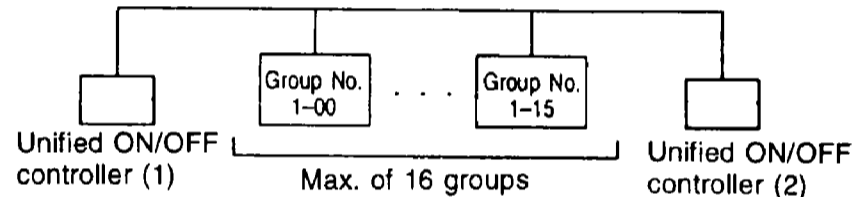


(Example)  
In the case of 1-00 to 1-15, attach 1.



③ MAIN/SUB changeover switch setting

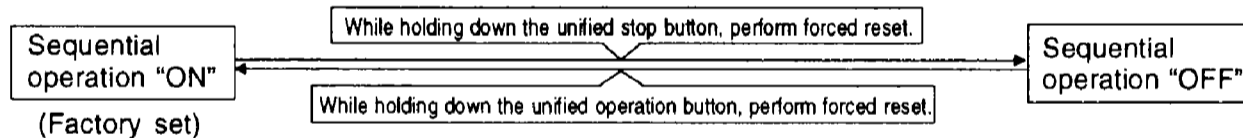
With two unified ON/OFF controllers, centralized control (indoor units) is possible from different locations. In this kind of set-up, it is necessary to set the MAIN/SUB changeover switch.



One of the two unified ON/OFF controllers (1)•(2) is set to "MAIN" while the other is set to "SUB".

④ Setting of the sequential operation function

The unified ON/OFF controller is equipped with a sequential operation function that sequentially turns indoor units on in 2-second intervals during unified operation. (Sequential operation is factory set to "ON.") To switch sequential operation ON or OFF, set as follows.



NOTE: The sequential operation function is designed to reduce the load on the power supply equipment, but does not guarantee that compressors will not be started simultaneously. You cannot therefore count on a capacity reduction effect by power supply equipment breaker selection.

⑤ Control mode selector (DS2)

The following four patterns of control mode can be set.

Control mode	Individual	Centralized	Timer operation possible by remote controller	ON/OFF control impossible by remote controller
Content	Operation/stop is controlled by both unified ON/OFF controller and remote controller.	After operated by unified ON/OFF controller, operation/stop is freely controlled by remote controller until stopped by unified ON/OFF controller.	When used in conjunction with schedule timer, operation/stop is controlled freely by remote controller during the set time but operation is not available when schedule timer is ON.	Operation/stop is controlled by unified ON/OFF controller only. (This unit can not be operated/stopped by remote controller.)
DS2 setting				
	(Factory set)			

NOTES) • ■ indicates the position of switches.

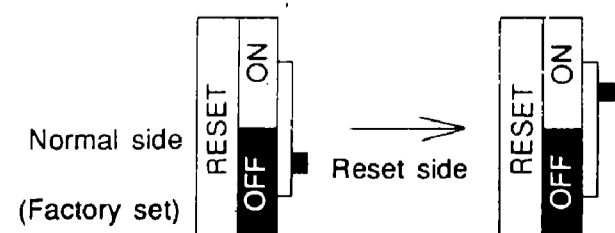
• Set control mode before turning power supply ON.

• When used in conjunction with central remote controller, the control modes of the central remote controller has the priority.

⑥ Forced reset switch (SS1)

When changing the setting of the connector for setting master controller, etc., you can reset simply by setting it to the reset side once and returning to the normal side, without turning the power OFF.

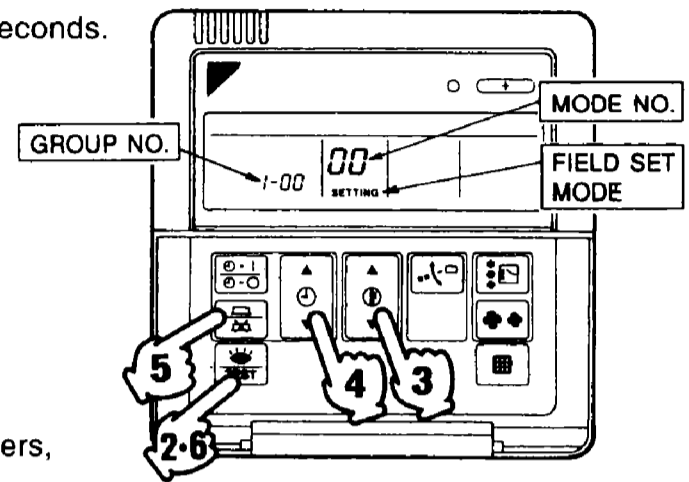
(For normal operation, set the switch to the normal side.)



## 6 SETTING GROUP NO. FOR CENTRALIZED CONTROL

Set the group number of each group of the indoor unit from the remote controller. (In case of no remote controller, also connect the remote controller and set the group No. Then, remove the remote controller.)

- ① Turn ON the power of the indoor unit and unified ON/OFF controller. (Unless the power is ON, no setting can be made.)  
Check that the installation and electrical wiring are correct before turning the power supply ON.  
When the power supply is turned ON, all LCD appear once and the unit may not accept the operation for about one minute with the display of " **HOST** " flashing (an interval of ON, ON, and OFF).
- ② While in the normal mode, hold down the " **TEST** " button for a minimum of 4 seconds.  
The remote controller will enter the FIELD SET MODE.
- ③ Select the MODE No. " 00 " with the " **MODE** " button.
- ④ Use the " **UP** " button to select the group No. for each group.  
(Group numbers increase in the order of 1-00, 1-01, ... 1-15, 2-00, ... 8-15.)
- ⑤ Press " **OK** " to set the selected group No.
- ⑥ Press " **TEST** " to return to the NORMAL MODE.



- NOTES)
- For simplified remote controller, see the installation table.
  - For setting group No. of HRV and wiring adaptor for other air conditioners, etc., refer to the instruction manual attached.

**NOTICE** Enter the group No. and installation place of the indoor unit into the attached installation table. Be sure to keep the installation table with the operation manual for maintenance.

## 7 CONFIRMING OPERATION

Before starting test operation, supply power to the indoor units, outdoor units, and unified ON/OFF controller and press the ON/OFF BUTTON.

If the operation lamp flashes, it indicates a malfunction in the indoor unit of the applicable group.

If the display of " **HOST** " flashes, it indicates a malfunction in the optional controllers for centralized control. Check for such malfunctions.

- NOTES**
- For test operation of indoor and outdoor units, refer to the installation manual attached with the outdoor unit.
  - After turning the power supply ON, if the unit does not accept operation for two minutes or more with the display of " **HOST** " flashing, check the following points.
    - Check that setting of the connector for setting master controller is correct.
    - Check that the group No. for centralized control has been set.

## 4 Schedule timer

DST301B61

### ★ Operation

## CAUTION DURING USE

- Do not tamper with the inner mechanism.  
Do not remove the front panel. Tampering the inner mechanism is dangerous and may damage equipment. For inspection and adjustment, ask your DAIKIN dealer.
- Avoid places where the unit may be contacted by water.  
Water penetrating the inner mechanism may cause electrical leakage, or render electric parts defective.
- Do not press the button on the schedule timer with a pointed hard tool.  
This may damage the schedule timer.
- Avoid direct exposure to sunlight.  
Direct sunlight may discolor the LCD and obscure the image.
- Do not wipe the surface of the operation panel with benzene, thinner or chemically treated dust cloth, etc.  
This may cause discoloring or peeling. To clean, moisten a cloth with a neutral cleanser diluted in water, rinse and wipe. Blot adhering water with a dry cloth.
- Never pull or twist the electric wire of the schedule timer.  
It can cause the unit to malfunction.
- Never inspect or service the schedule timer by yourself.  
Ask a qualified service person to perform this work.

## FEATURES AND FUNCTIONS

### ■ Operation controlled by programmed time

Operating time and stopping time can be set to the minute by each day of the week. The operating and stopping patterns can also be set in schedule according to the time slot given twice a day in tune with the uses.



See page 102–105.

### ■ Unified Operation/Stop

By using this schedule timer, the unified operation/stop of the indoor unit can be executed manually regardless of the No. of programmed time in operation.

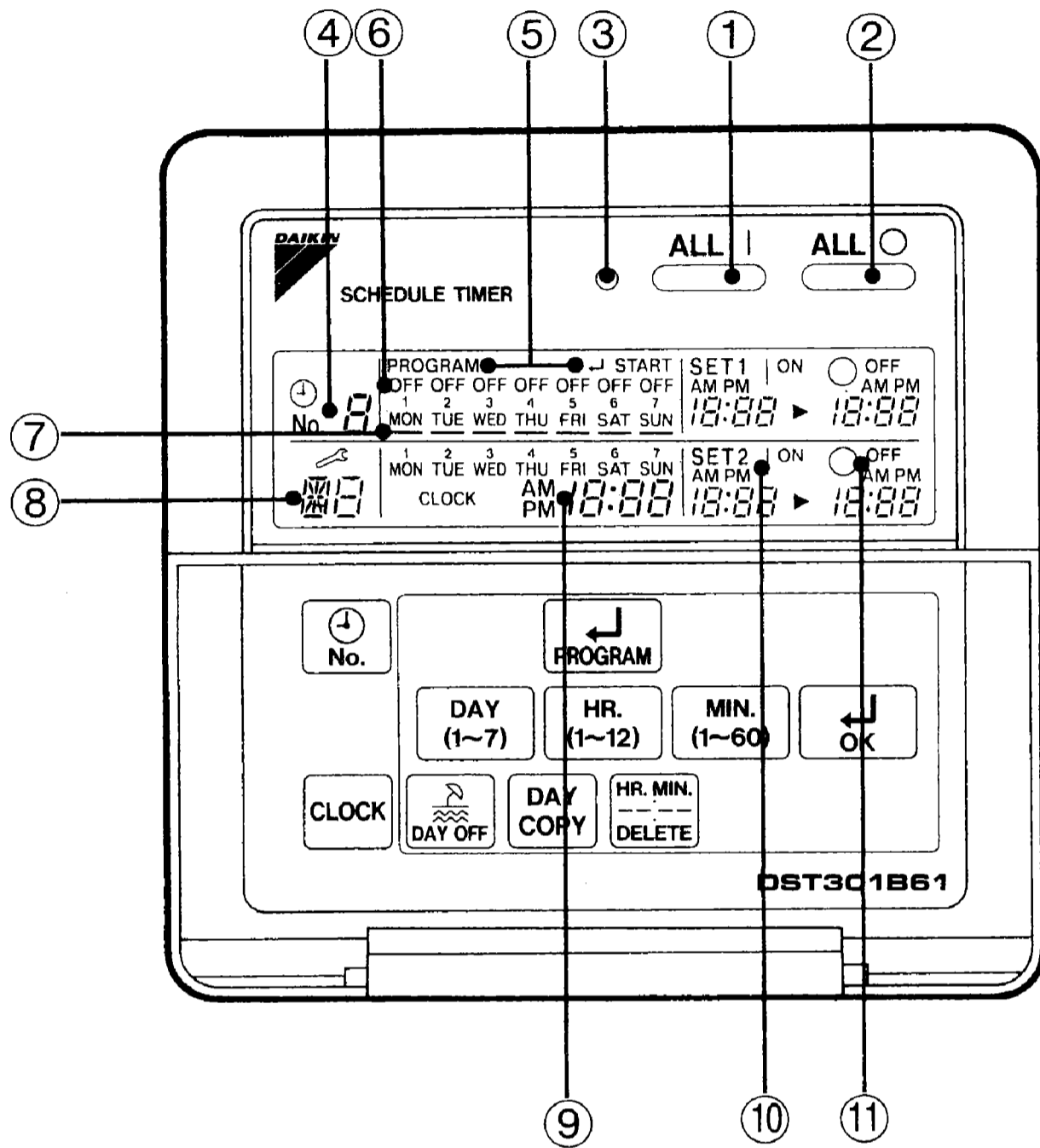


See page 105–106.

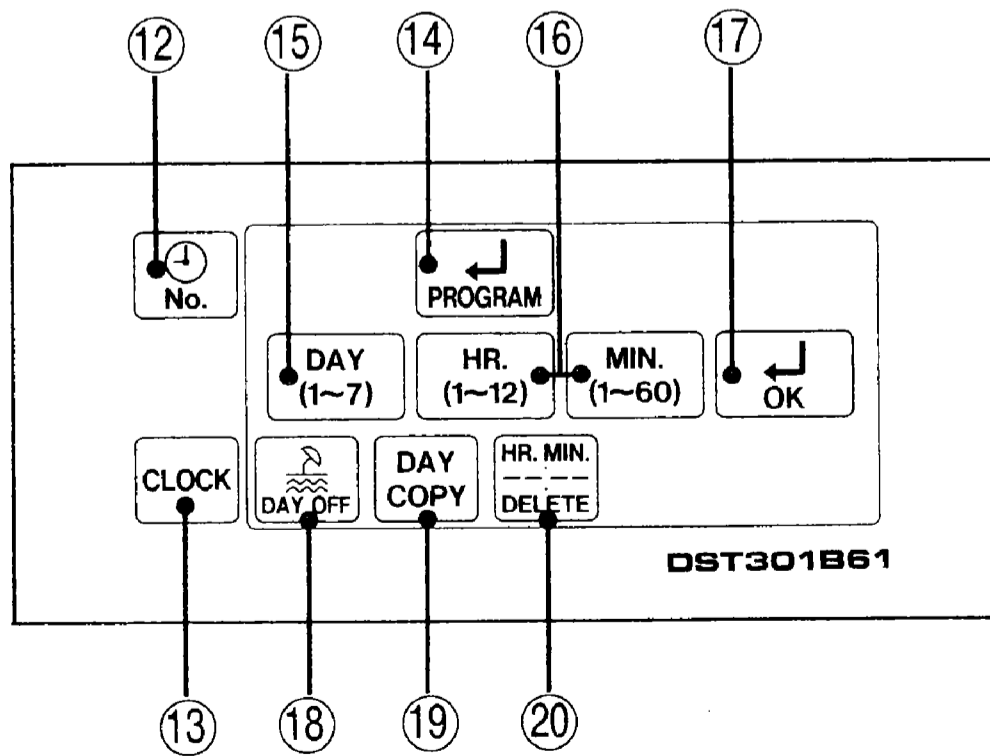
### ■ When used in conjunction with central remote controller (Optional Accessory)

The operation controlled by programmed time can be set for up to eight different patterns (timer No. 1 – 8). Each schedule pattern can be also selected.

# 1

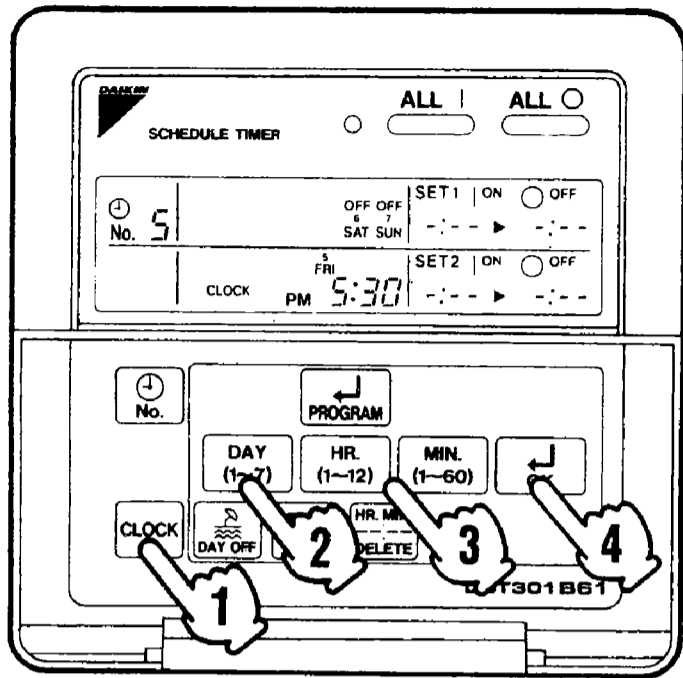


# 2

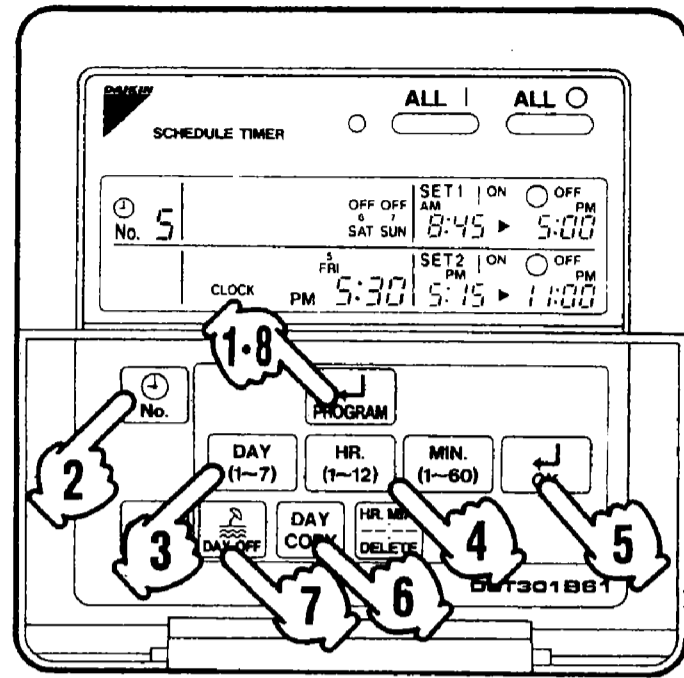




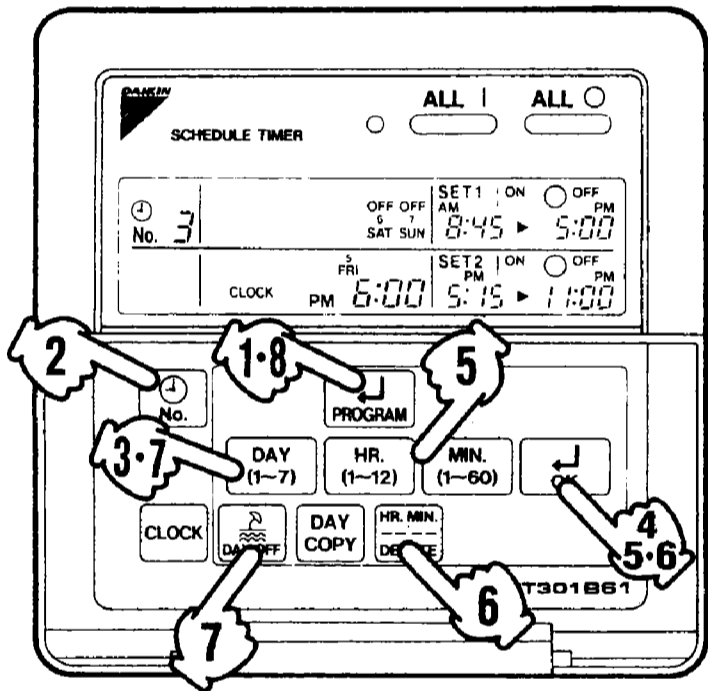
3



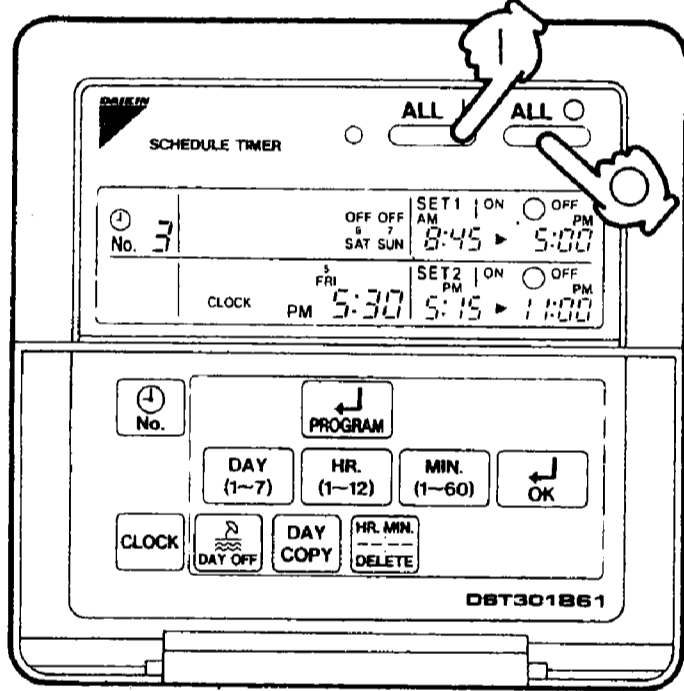
4



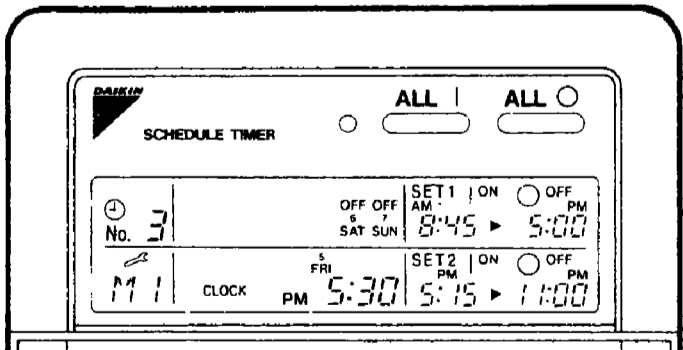
5






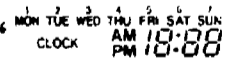
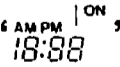
6



7



# NAMES AND FUNCTIONS OF OPERATING SECTION (Fig. 1, 2)

①	<b>UNIFIED OPERATION BUTTON</b>	⑪	<b>DISPLAY “” (PROGRAMMED TIME OF SYSTEM OFF)</b>
	Press this button to perform the unified operation regardless of the No. of programmed time.		Displays the time programmed to stop.
②	<b>UNIFIED STOP BUTTON</b>	⑫	<b>TIME NO. BUTTON</b>
	Press this button to perform the unified stop regardless of the No. of programmed time.		See page 102–105
③	<b>OPERATION LAMP (RED)</b>	⑬	<b>CLOCK ADJUSTING BUTTON</b>
	The light turns on during the operation of the indoor unit.		Press this button to set the present time.
④	<b>DISPLAY “” (TIME NO.)</b>	⑭	<b>PROGRAMMING START BUTTON</b>
	Displays the time No. only when used in conjunction with the central remote controller.		Press this button to set or check the No. of programmed time. Press it again after you are through with the program.
⑤	<b>DISPLAY “PROGRAM ↵ START.” (PROGRAMMING START)</b>	⑮	<b>BUTTON FOR SELECTING DAYS OF A WEEK</b>
	The light turns on when the timer is programmed.		Press this button to select the day of the week.
⑥	<b>DISPLAY “ OFF ” (HOLIDAY SETTING)</b>	⑯	<b>HOUR/MINUTE BUTTON</b>
	Lights above the day of the week set as holiday. The operation controlled by timer is not available on that day.		Press this button to adjust the present time and the programmed time.
⑦	<b>DISPLAY “ — ” (SETTING OF DAYS OF A WEEK)</b>	⑰	<b>TIMER ON BUTTON</b>
	Flashes below the day of the week programmed.		Press this button to set the present time and the programmed time.
⑧	<b>DISPLAY “” (MALFUNCTION CODE)</b>	⑱	<b>HOLIDAY SETTING BUTTON</b>
	Displays the contents of malfunction during the stop due to malfunction.		Press this button to set holidays.
⑨	<b>DISPLAY “” (PRESENT TIME)</b>	⑳	<b>BUTTON FOR COPYING PROGRAM OF PREVIOUS DAY</b>
	Displays the present day of the week and time.		Use this button to set the No. of programmed time same as that of the previous day.
⑩	<b>DISPLAY “” (PROGRAMMED TIME OF SYSTEM START)</b>		<b>PROGRAM CANCELING BUTTON</b>
	Displays the time programmed to start.		Use this button to set the programmed time to cancel. The display shows “ — ; — — ”.

Note) 1: Please note that all the displays in the figure appear for explanation purpose or when the cover is open.

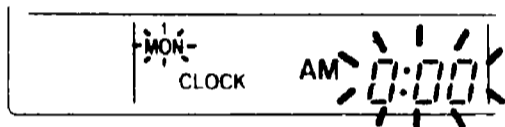
# OPERATION

## SETTING PRESENT TIME (Fig. 3)

(Example) In case of setting Friday, 5:30 p.m.

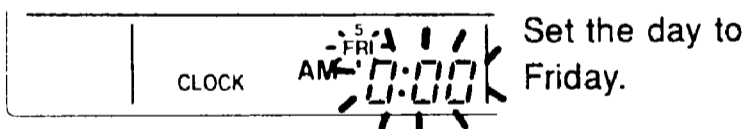
**1** Press the **CLOCK ADJUSTING BUTTON**. The present time display flashes.

Note): • The present time needs adjusting in case of turning power supply on for the first time or the occurrence of power failure over the period of 48 hours or more.



**2** Press the **BUTTON FOR SELECTING DAYS OF A WEEK**. Each time the button is pressed, the day display shifts to the right.

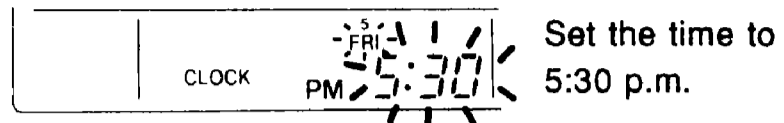
Note): • The display "MON" follows the display "SUN."



**3** Set the time with the **HOUR/MINUTE BUTTON**. Each time the **HOUR/MINUTE BUTTON** is pressed, the display is put forward minute by minute and hour by hour. When the button is kept pressed, the display is put forward continuously.

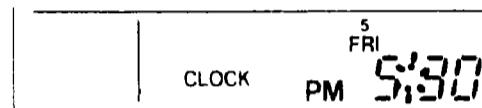
Note): • After becoming "AM 11:00", when the button is pressed, the display becomes "PM 0:00".

- After becoming "59" (minute), when the button is pressed, the display becomes "00" (minute).



Set the time to 5:30 p.m.

**4** Press the **TIMER ON BUTTON** the moment the time signal of TV, radio, telephone, etc. is heard. The mark ":" flashes, and the clock starts.



Press the **TIMER ON BUTTON** in tune with the time signal at 5:30 p.m.

Note)

- The clock used is of 12-hour type.
- When you turn power supply on, the system may display "88" for about one minute and not start to operate after all the liquid crystal displays appear at a time.
- If the **CLOCK ADJUSTING BUTTON** is pressed by mistake, press it again to return to the original state. As the clock does not stop, the time indicated by the clock is kept correct. In case of power failure within 48 hours, the clock keeps operating by utilizing the built-in battery.

## SETTING NO. OF PROGRAMMED TIME (Fig. 4)

(Example) Time No. 5 (to be programmed only when used in conjunction with the central remote controller)

Monday to Friday:

Operating from 8:45 a.m. till 5:00 p.m.

Operating from 5:15 p.m. till 11:00 p.m.

Saturday and Sunday:

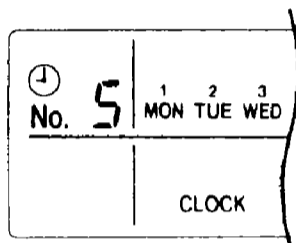
Setting the whole day stop operation (application for holidays) controlled by programmed time.

**1** Press the **PROGRAMMING START BUTTON**. Programming is available. The display "PROGRAM → START" appears, and the display of days of a week flashes.

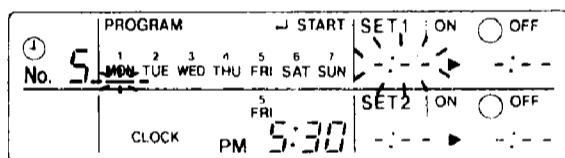
**2** Press the **TIME No. BUTTON**, and select the desired number.

Note): Unless used in conjunction with the central remote controller, The TIME No. is not displayed and can not be selected.

Select the TIME No. 5.



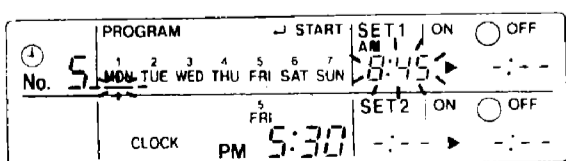
**3** Press the **BUTTON FOR SELECTING DAYS OF A WEEK**, and set the proper day of the week. Each time you press it, the flashing display of days of a week shifts to the right.



Set to Monday.

**(1) Setting programmed time**

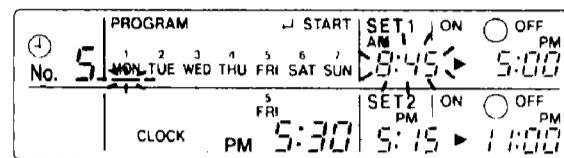
**4** Set the programmed time of system start 1 by using the **HOUR/MINUTE BUTTON**. Each time the **HOUR/MINUTE BUTTON** is pressed, the display is put forward minute by minute and hour by hour. When the button is kept pressed, the display is put forward continuously.



Set the programmed time of system start 1 at 8:45 a.m.

**5** Press the **TIMER ON BUTTON**, and set the programmed time of system start 1. Each time you press it, the next area to be set flashes.

Note): Set the other programmed time in the same procedure.



**(2) Set the next day of the week.**

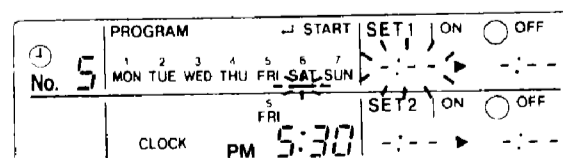
Set the day of the week to Tuesday, and copy the program of the previous day (Monday). In the same procedure, set the day of the week to Wednesday through Friday in sequence.

**6** Press the **BUTTON FOR SELECTING DAYS OF A WEEK** and set the following day. Press the **BUTTON FOR COPYING PROGRAM OF PREVIOUS DAY**. The same program as that of the immediately preceding day of the week is set.

Note) Repeat each procedure 3 – 5 in the above when not copying the contents of the previous day.

**(3) Holiday setting**

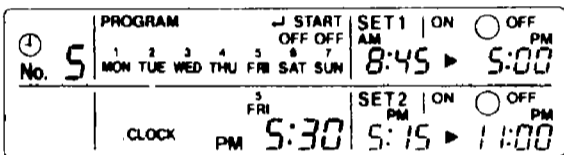
**7** Press the **BUTTON FOR SELECTING DAYS OF A WEEK** and set one or more days of the week as holiday. Press the **HOLIDAY SETTING BUTTON**, and the display "OFF" is displayed at the top of the day of the week. If you press it again, the display returns to the original state.



Set Saturday and Sunday as holidays.

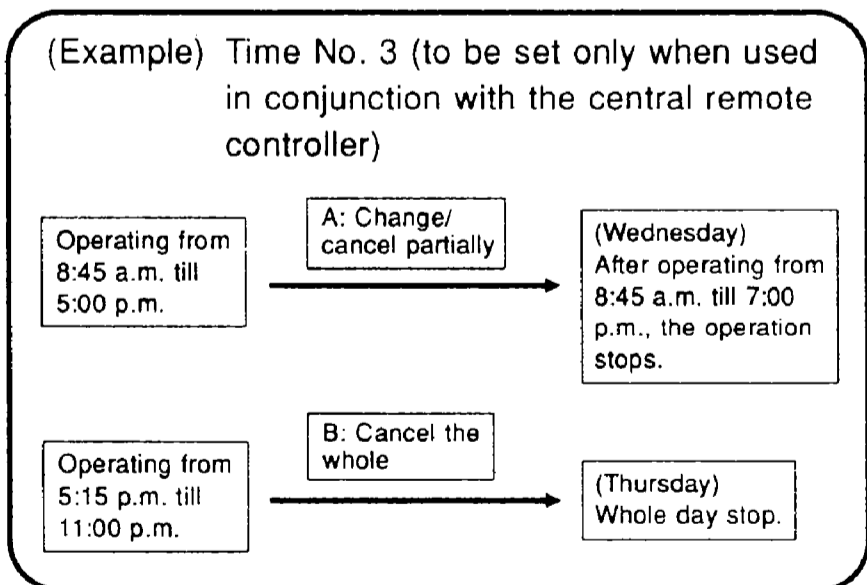
**8** Press the **PROGRAMMING START BUTTON**, and finish the program setting.

- Note)
- Unless the button is pressed within 20 minutes, the display will automatically revert back to the original state. In this case, setting contents up to the point where the **TIMER ON BUTTON** (or **HOLIDAY SETTING BUTTON** or **BUTTON FOR COPYING PROGRAM OF PREVIOUS DAY**) is pressed will only take effect.
  - The display "PROGRAM ↵ START" and the display of days of a week "—" disappears.
  - The flashing display goes off, and the No. of programmed time of the present day is displayed. Then the operation controlled by timer starts.
  - The operation controlled by timer is executed even while the program is being set.



This is the end of the setting example.

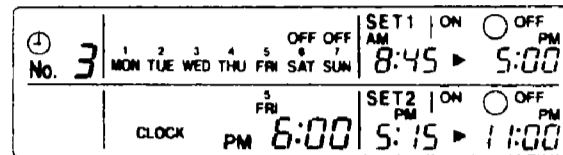
## CHANGE AND CANCELLATION OF NO. OF PROGRAMMED TIME (Fig. 5)



**1** Press the **PROGRAMMING START BUTTON**. The program setting is ready. The display "PROGRAM ↵ START" appears,

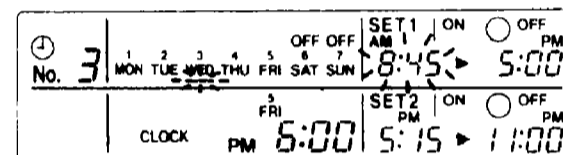
and the display of days of a week flashes.

**2** Press the **TIME No. BUTTON**, and select the desired No.



Select the time No. 3.

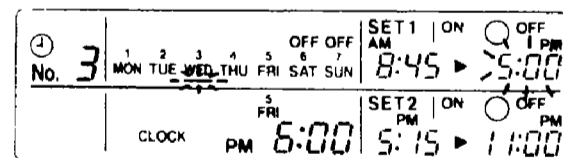
**3** Press the **BUTTON FOR SELECTING DAYS OF A WEEK**, and set the day of the week to be changed. The set No. of programmed time of the day of the week is displayed.



Set the day to Wednesday.

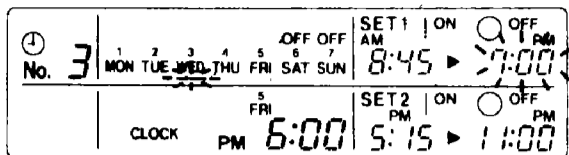
### A. Change/cancel partially

**4** Press the **TIMER ON BUTTON** and change, and the display of programmed time flashes. Each time you press it, the next area to be set flashes.



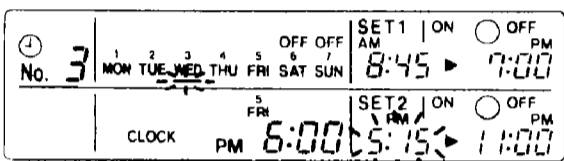
Shift to the display "PROGRAMMED TIME OF SYSTEM OFF."

**5** Press the **HOUR/MINUTE BUTTON** and change the programmed time. Press the **TIMER ON BUTTON**, and finalize the setting of change.

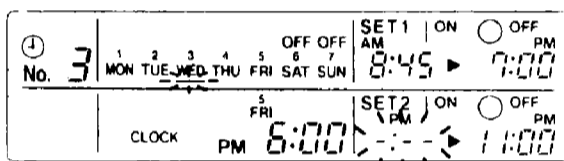


Change the programmed time of system OFF p 1 to 7:00 p.m.

**6** Press the **PROGRAM CANCELING BUTTON**, and cancel the programmed time. If you press it again, display returns to the original state. Press the **TIMER ON BUTTON** to finalize the cancellation.



Shift to the programmed time of system start 2.

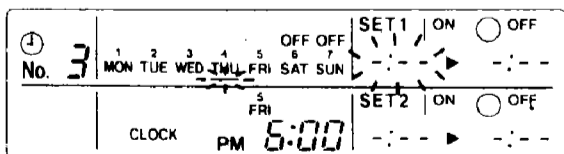


Set the programmed time of system start 2 to program cancellation.

In the same procedure, cancel the programmed time of system off 2.

## B. Cancel the whole

**7** Press the **BUTTON FOR SELECTING DAYS OF A WEEK**, and shift to the day of the week to be canceled. Then, press the **HOLIDAY SETTING BUTTON**; the display "OFF" appears at the top of the particular day of the week. The programmed time is canceled. If you press the button again, the display returns to the original state.



Shift the day of the week to Thursday to set as a holiday.

**8** Press the **PROGRAMMING START BUTTON**. The program setting is now finished.

- Note)
- Unless the button is pressed within 20 minutes, the display will automatically revert back to the original state. In this case, setting contents to the point where the **TIMER ON BUTTON** (or **HOLIDAY SETTING BUTTON** or **BUTTON FOR COPYING PROGRAM OF PREVIOUS DAY**) is pressed will only take effect.
  - To continue the change/cancellation, do not press the **PROGRAMMING START BUTTON** until all change/cancellation are completed.
  - The operation controlled by timer is executed even while the program is being set.

## MANUAL OPERATION (Fig. 6)

This schedule timer enables the operation/stop by pressing the **UNIFIED OPERATION/STOP BUTTON** in addition to the operation controlled by timer (operation/stop according to the programmed time) at any time.

**9** Press the **UNIFIED OPERATION BUTTON**, and the **OPERATION LAMP** turns on.

**10** Press the **UNIFIED STOP BUTTON**, and the **OPERATION LAMP** is turned off.

- Note)
- The operation automatically stops according to the programmed time of system off even during the manual operation. In the meantime, the operation starts automatically according to the programmed time of system start even during the stop of operation.
  - If the unit is used in conjunction with other optional controllers for centralized control, the **OPERATION LAMP** of the unit that is not under operation control may be turned on or off a few minutes behind schedule. This shows that the signal is being exchanged, and does not indicate any failure.

Operation lamp	
○ Turn on:	The light turns on when any of the indoor units is in operation whether the operation is controlled by timer or by hand.
● Turn off:	The light turns off when all the indoor units stop.

## OPERATION CONTROL CODE

Two different types of operation control codes can be selected when this kit is used independently (when not used in conjunction with the central remote controller, unified ON/OFF controller, etc.).

### ■ Individual

In case where the operation/ stop is controlled by both schedule timer and remote controller.

### ■ Centralized

The operation is controlled by the schedule timer alone, and the operation/stop is controlled freely with the remote controller during the programmed time.

### Notes)

- For current settings, contact your DAIKIN dealer.
- To change settings, contact your DAIKIN dealer.  
Do not change settings yourself.

## ERROR DIAGNOSING FUNCTION (Fig. 7)

This schedule timer is provided with the malfunction diagnosing function. The malfunction code flashes if there occurs any malfunction in communication, etc. between and among the optional controllers for centralized control. In addition, the operation lamp also flashes if there occurs any malfunction in communication with the indoor unit. Check the contents of the display and contact your DAIKIN dealer because the signals give you the idea of the trouble area.

Operation lamp	Malfunction code	Contents of malfunction
Turn off	M1	Failure of PC board of schedule timer.
Turn on or off	M8	Malfunction of transmission between each optional controllers for centralized control.
Turn on or off	MA	Improper combination of optional controllers for centralized control.
Turn on or off	MC	Address failure of schedule timer.
Flash	UE	Malfunction of transmission between indoor unit and optional controllers for centralized control.
Flash	—	Malfunction in indoor unit (Refer to the malfunction codes of the indoor remote controller, while also read the "CAUTION FOR SERVICING" attached to the indoor unit.)

# 1 ACCESSORIES

Check the following accessories are included in the kit before installation.

Body	1	Installation screws (M4 x 16)	2
Operation manual	1	Attached electric wire (for individual use)	1
Installation manual	2	Crimp style terminal (for individual use)	2

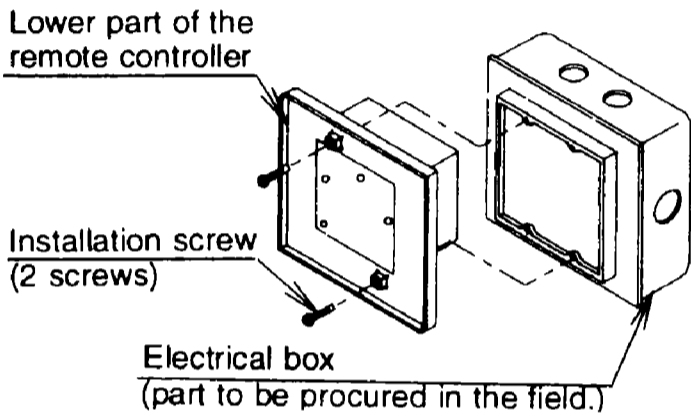
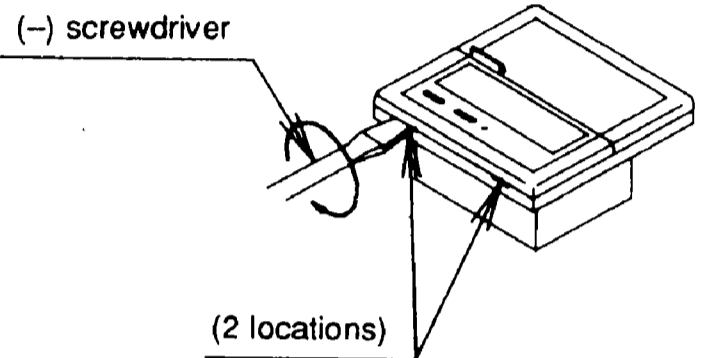
For installation, a electrical box to be embedded is necessary (part to be procured in the field/with covers).

# 2 INSTALLATION AND INITIAL SETTING

## 1. Remove the upper part of the remote controller.

- Insert a (-) screwdriver (2 locations) into the recess between the upper part and the lower part of the remote controller and twist the screwdriver lightly.

(The PC board is attached with the upper part of the remote controller. Do not damage electric parts with a screwdriver, etc.)



- Attach the lower part to the electrical box (part to be procured in the field) with the provided installation screws. (Select a flat face as a installation place. Do not tighten the installation screws excessively not to damage the lower part of the remote controller.)

For part to be procured in the field electrical box, use KJB211A (optional accessory).

## 2. Initial setting

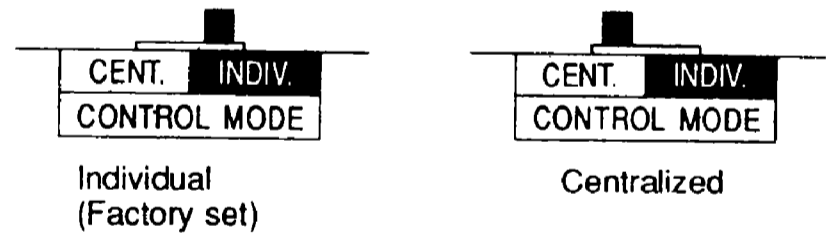
### ① Setting connector for individual use (X1A) (Factory set : OFF) (Set for individual use only)

- For individual use of schedule timer  
Insert the connector attached with the body case on the PC board.
- For combined use with other optional controllers for centralized control  
Do not change the factory setting.

### ② Control mode selector (SS2)(Set for individual use only)

By changing the switch, setting mode of individual and centralized operation is available.

Note) When used with other optional controllers, control mode of central remote controller and unified ON/OFF controller have the priority.

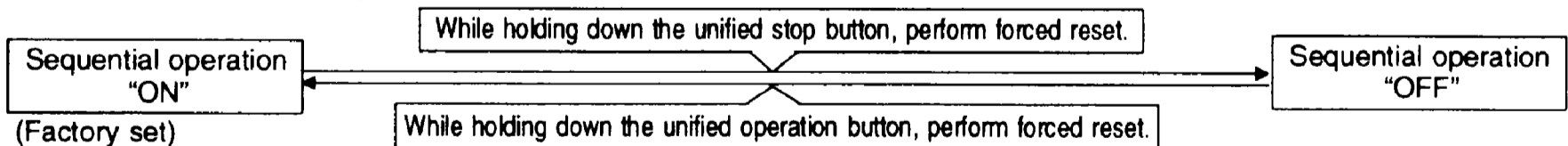


### ③ Setting of the sequential operation function

The schedule timer is equipped with a sequential operation function that sequentially turns indoor units on in 2-second intervals during unified operation.

(Sequential operation is factory set to "ON.")

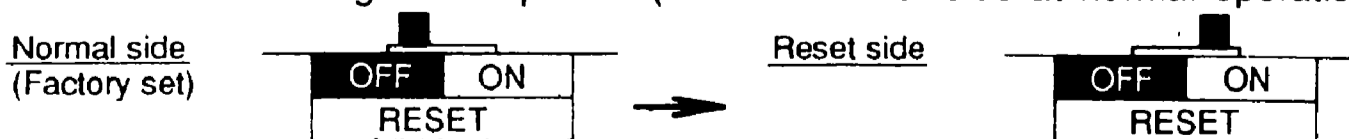
To switch sequential operation ON or OFF, set as follows.



Note) The sequential operation function is designed to reduce the load on the power supply equipment, but does not guarantee that compressors will not be started simultaneously. You cannot therefore count on a capacity reduction effect by power supply equipment breaker selection.

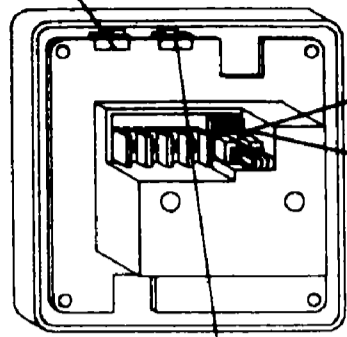
### ④ Forced reset switch (SS1)

When changing the setting of the connector for individual use, etc., the switch can be reset simply by setting it to the reset side once and returning to the normal side. This procedure enables to reset without turning off the power. (Set the normal side at normal operation.)



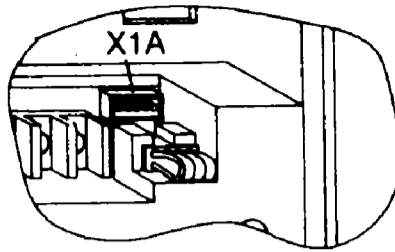


Control mode selector.

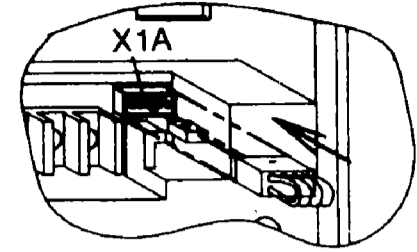


Forced reset switch

Individual use setting connector



In case of combined use with other optional controllers for centralized control (Factory set)



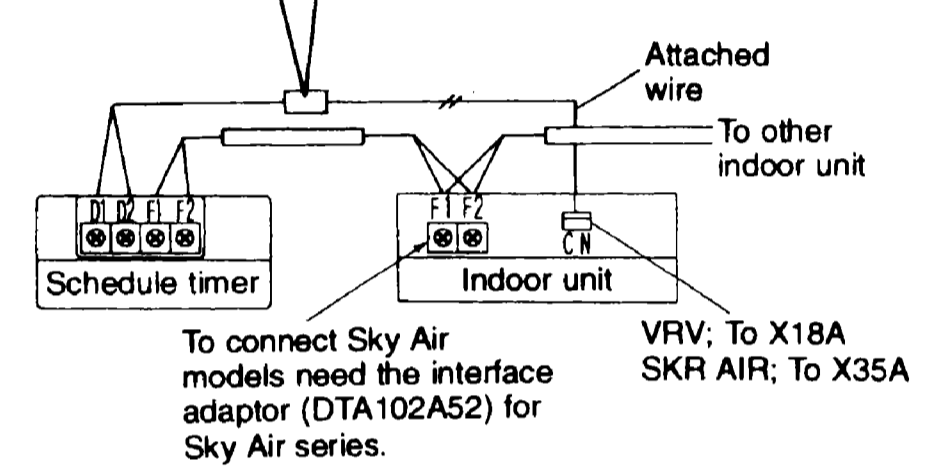
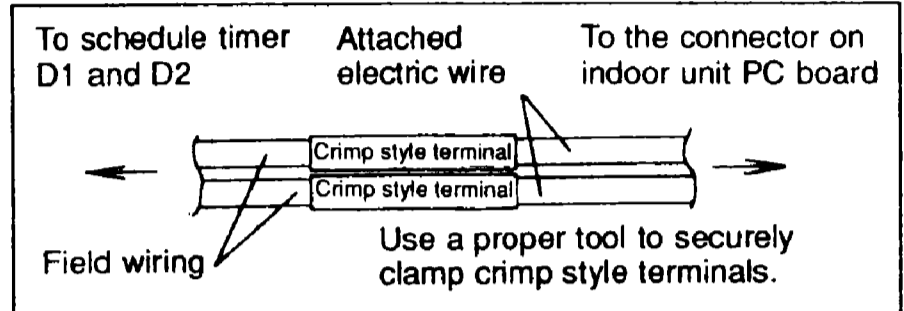
In case of individual use of schedule timer

### 3. Transmission wiring

- In case of individual use of schedule timer  
Connect terminals of the schedule timer (F1, F2) with terminals of the indoor unit (F1, F2). Connect terminals of the schedule timer (D1, D2) and the connector on the indoor unit PC board, using the attached electric wire and crimp style terminals.

Prevent the connection part of crimp style terminal from getting out of the electric parts box of indoor unit.

- In case of combined use with other optional controllers for centralized control  
Connect terminals of the schedule timer (F1, F2, D1, D2) and the terminals of the central remote controller (or unified ON/OFF controller).

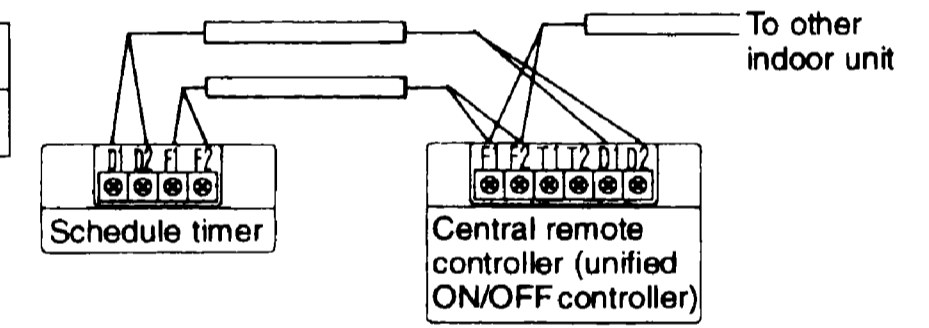


#### Wiring Specifications

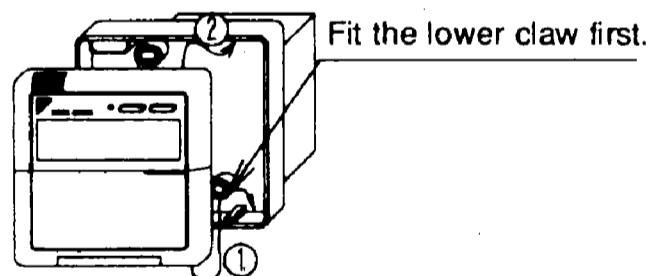
Wiring Type	Sheathed Wire (2 wire)
Size	0.75 - 1.25 mm <sup>2</sup>

#### NOTES:

- Electrical box and transmission wiring are not attached.
- Do not touch the PC board with your hand.



### 4. Install the upper part of the remote controller as before.



## 3 SETTING GROUP NO. FOR CENTRALIZED CONTROL

- In case of individual use of schedule timer  
Group number setting is not necessary. It is automatically set when turning power supply ON.
- In case of combined use with other optional controllers for centralized control  
See the installation manual of the optional controllers to be used together.

## 4 TEST OPERATION

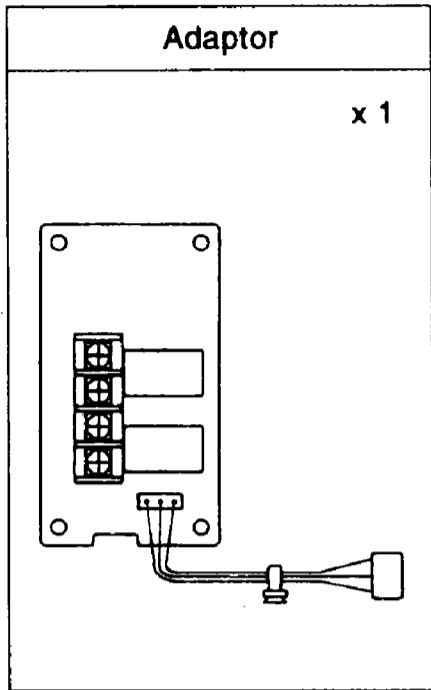
Refer to the installation manual attached to the outdoor unit.

In case the schedule timer is used individually and the wiring is changed after the system has been operated, reset the power after energizing for more than five minutes. It may not be possible to control the unit from the schedule timer.

# 5 Adaptor for wiring

KRP1B51 · 54 · 56 · 57

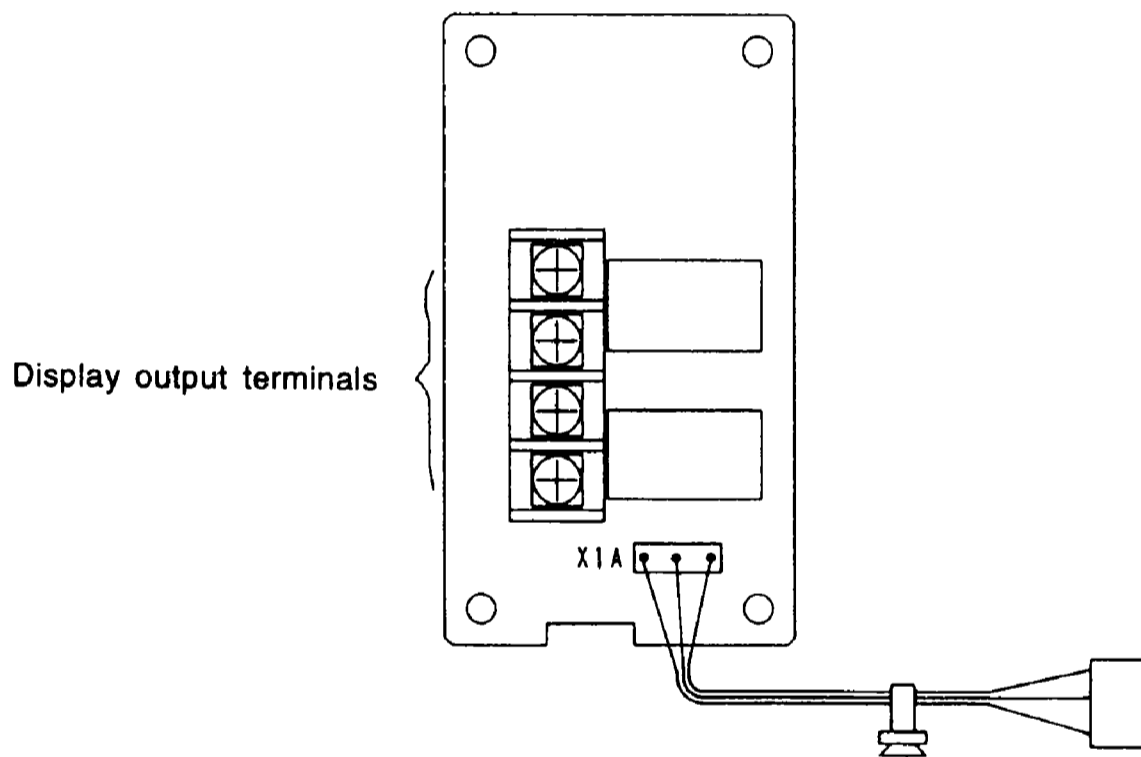
**Accessories** Check if the following accessories are included in the kit.



PC board support	x 4
Tie wrap	x 3
Installation manual	x 1

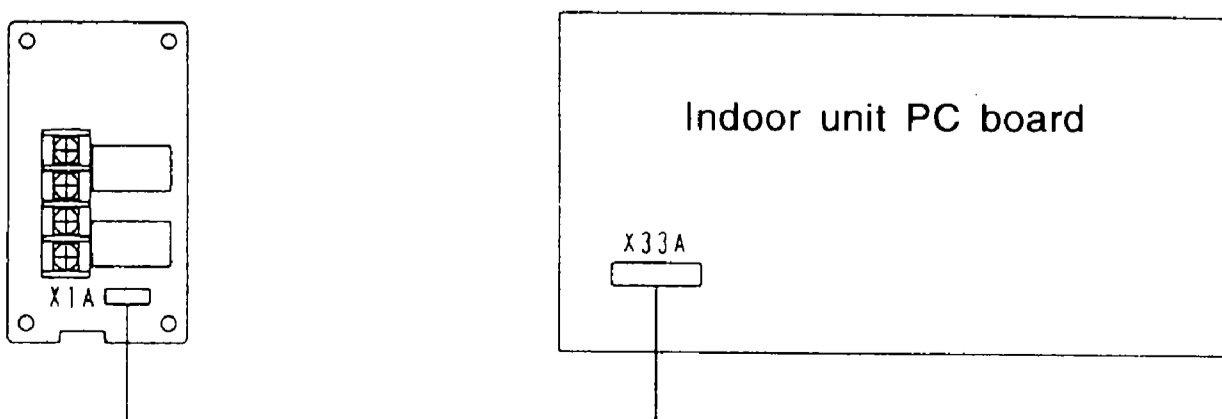
- NOTE**
- Kits vary according to applicable models.
  - A special adaptor fixing plate and box are required for the following models.  
 FH(Y)C ..... KRP1B94  
 FVY ..... KRP1B95

## 1 NAMES OF PARTS



## 2 ELECTRIC WIRING

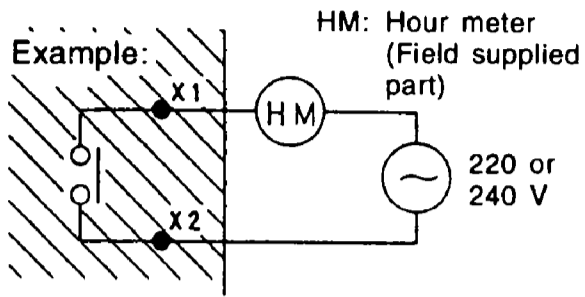
- Refer to the WIRING DIAGRAM attached to the indoor unit before attempting to wire.  
 [Make sure wires to units do not pass over the PC board when wiring.]
- Wire the adaptor to the indoor unit as described below.



① Fetching the operation display signal

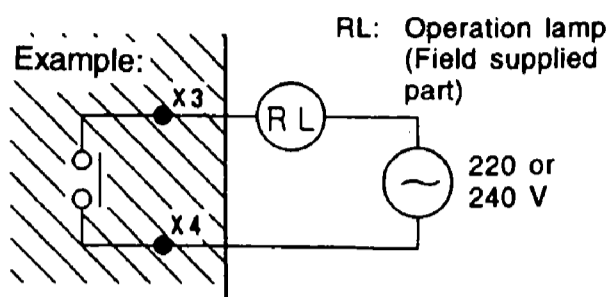
• Attaching an hour meter

Output is generated at the contact while the compressor is running.



• Fan ON display

Output is generated at the contact while the fan is running.

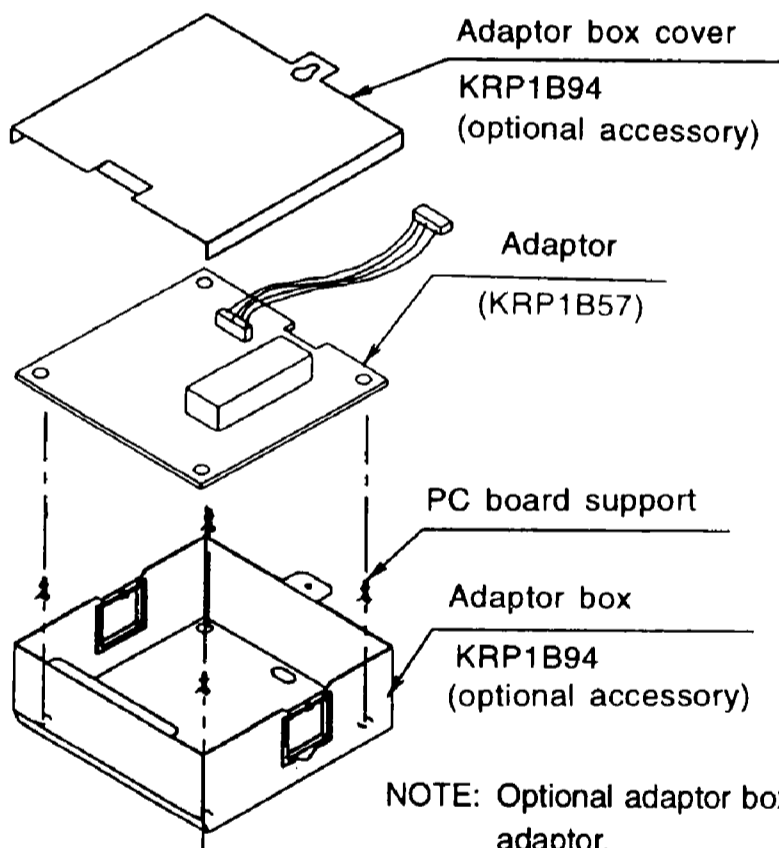


### 3 INSTALLATION

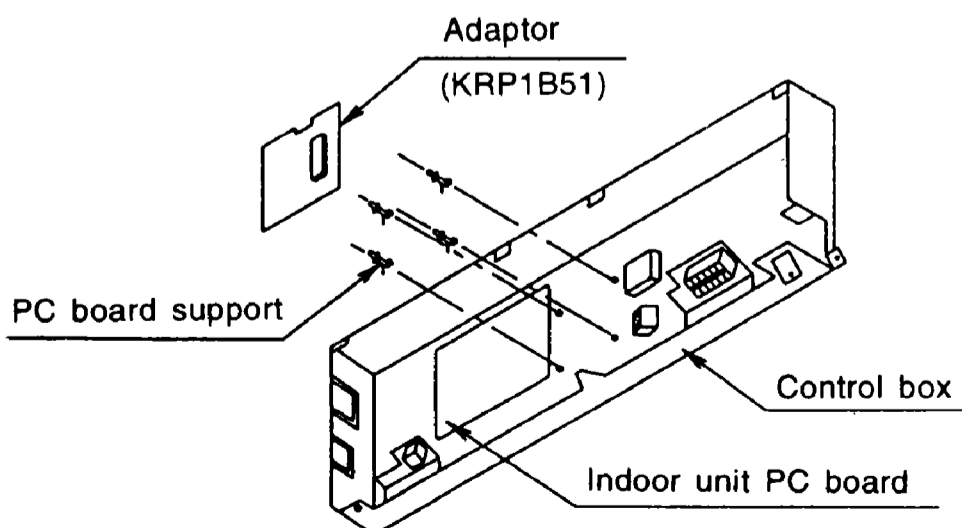
- Installation differs according to models as shown below.
- Do not bundle low and high voltage wires together.
- Bundle any excess wires with the attached tie wraps so as to keep loose wirings off the indoor unit PC board.

《 Ceiling-mounted cassette type 》

**FH(Y)C** (Multiflow type)



**FH(Y)K** (Corner type)



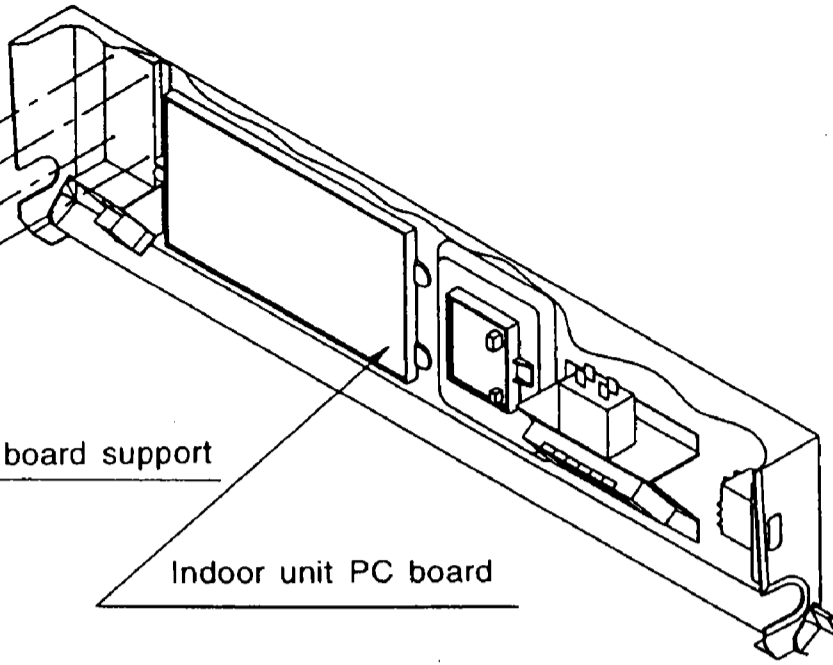
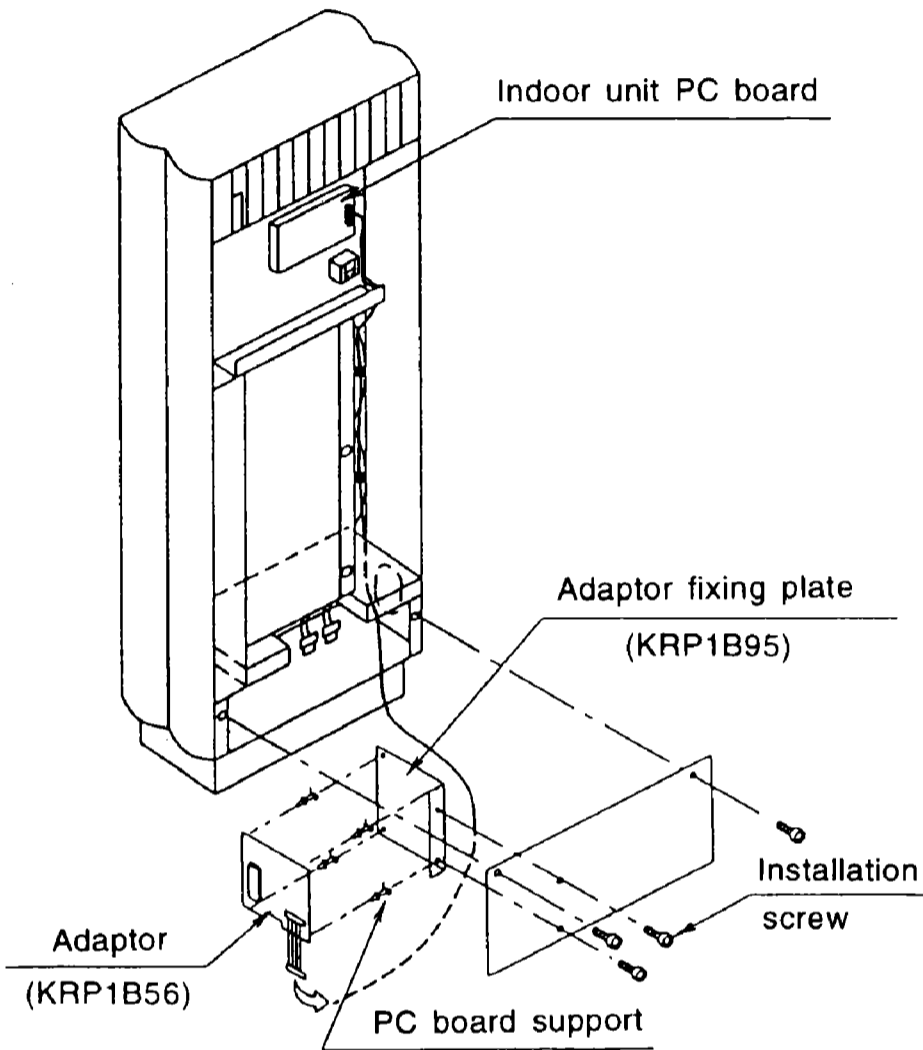
《 Ceiling suspended type 》

**FH(Y)**

Adaptor  
(KRP1B54)

《 Floor-standing type 》

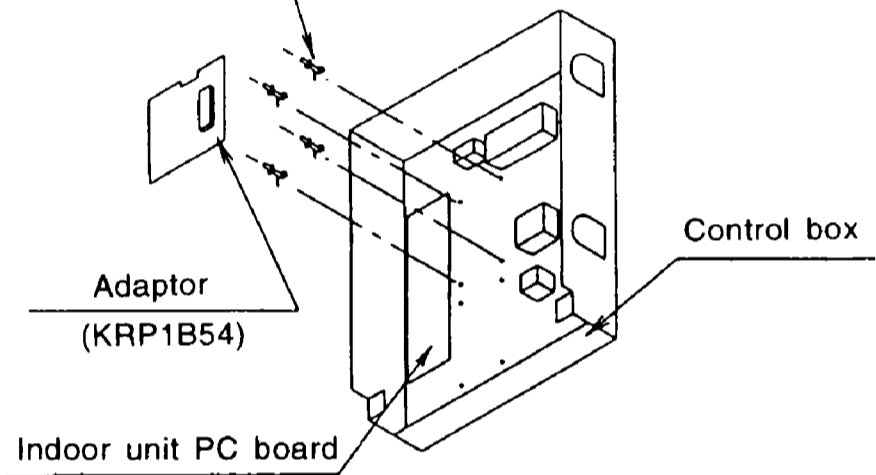
**FVY**



《 Ceiling-mounted built-in type 》

**FH(YB)**

PC board support



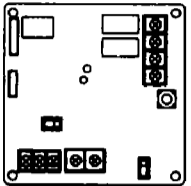


NOTE: Optional adaptor box is required to install the adaptor.

# 6 Wiring adaptor for electrical appendices

KRP4A51 · 52 · 53 · 54

## Accessories

Check if the following accessories are included in the kit.

Adaptor	Relay harness
x 1	x 1 each
	(1)  (2) 

PC board support	x 4
Tie wrap	x 3
Installation manual	x 3

## NOTE

- Kits vary according to applicable models.
- A special adaptor fixing plate and box are required for the following models.

FH(Y)C ..... KRP1B94  
 FVY ..... KRP4A90  
 FH(Y) ..... KRP1B93

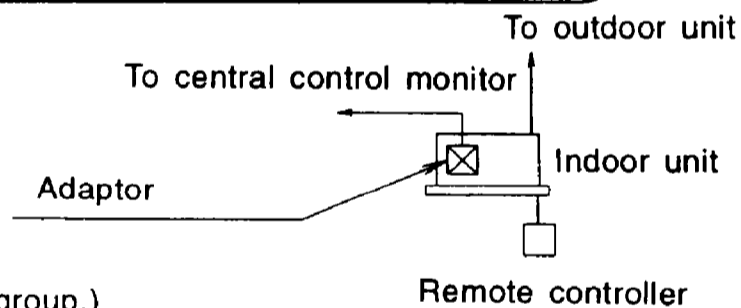
## 1 SYSTEM OUTLINE

This kit enables remote control (ON/OFF control, temperature setting, operation display, error display) and can be used with the following systems though it cannot be used in conjunction with other optional controllers for centralized control.

1. Individual control (Each indoor unit is controlled individually.)

This system requires the following parts.

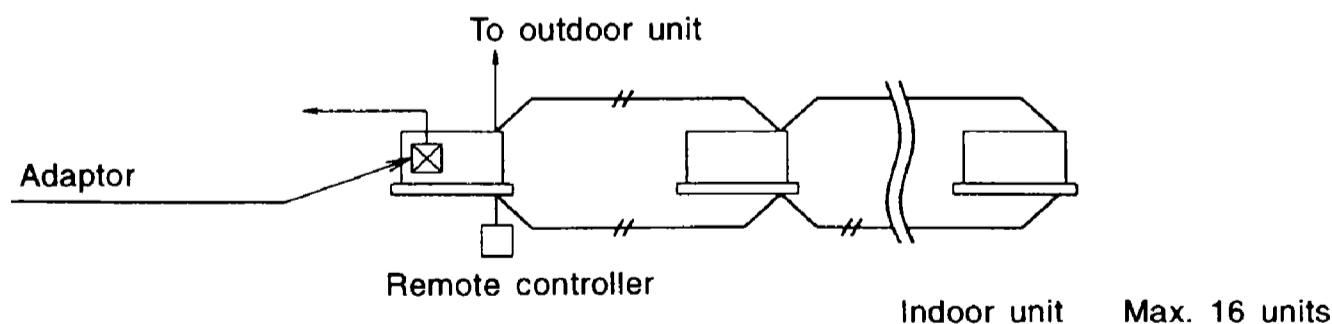
- Adaptor ..... KRP4A51 · 52 · 53 · 54      Any one kit
  - Remote controller (For operation control) ..... BRC1B51 · 52 · 61 · 62      Any one kit
- (Ex.) When individually controlling 8 FHYC71F units
- KRP4A51 x 8 kits
  - BRC1B61 x 8 kits



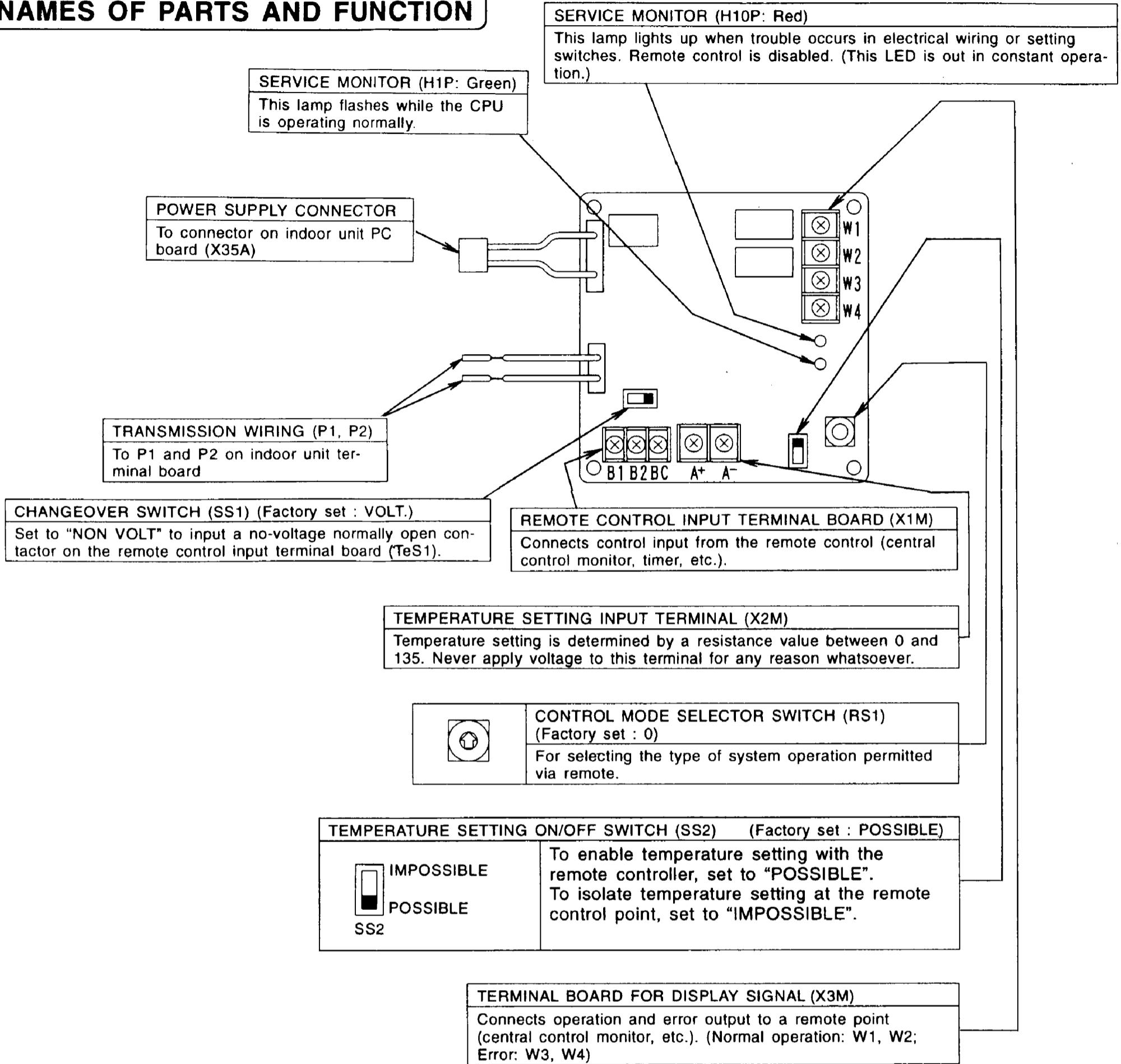
2. Group control (Multiple indoor units are controlled as a group.)

This system requires the following parts.

- Adaptor ..... KRP4A51 · 52 · 53 · 54      Any one kit
- Remote controller (For operation control) ..... BRC1B51 · 52 · 61 · 62      Any one kit



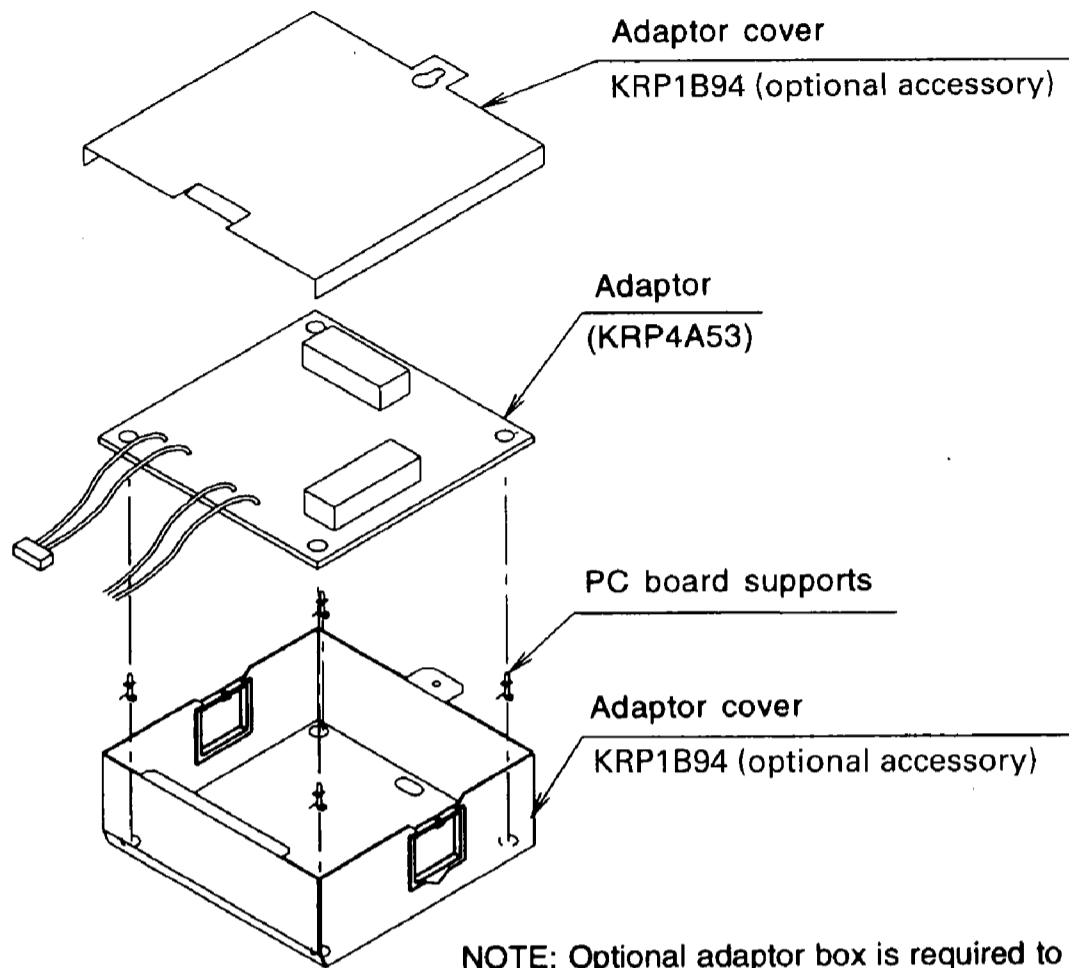
## 2 NAMES OF PARTS AND FUNCTION



### 3 INSTALLATION

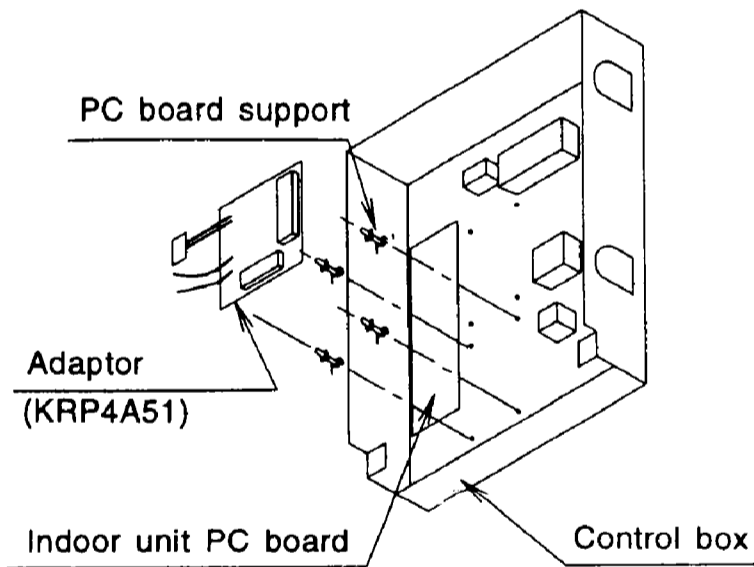
#### << Ceiling-mounted cassette type >>

**FH(Y)C** (Multiflow type)



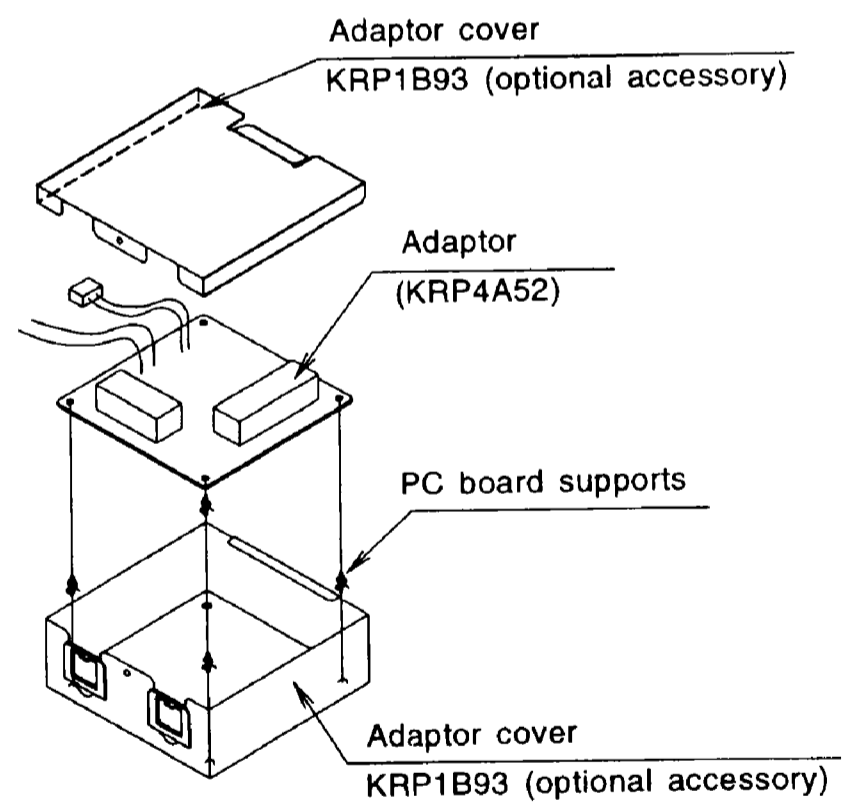
#### << Ceiling-mounted built-in type >>

**FH(Y)B**

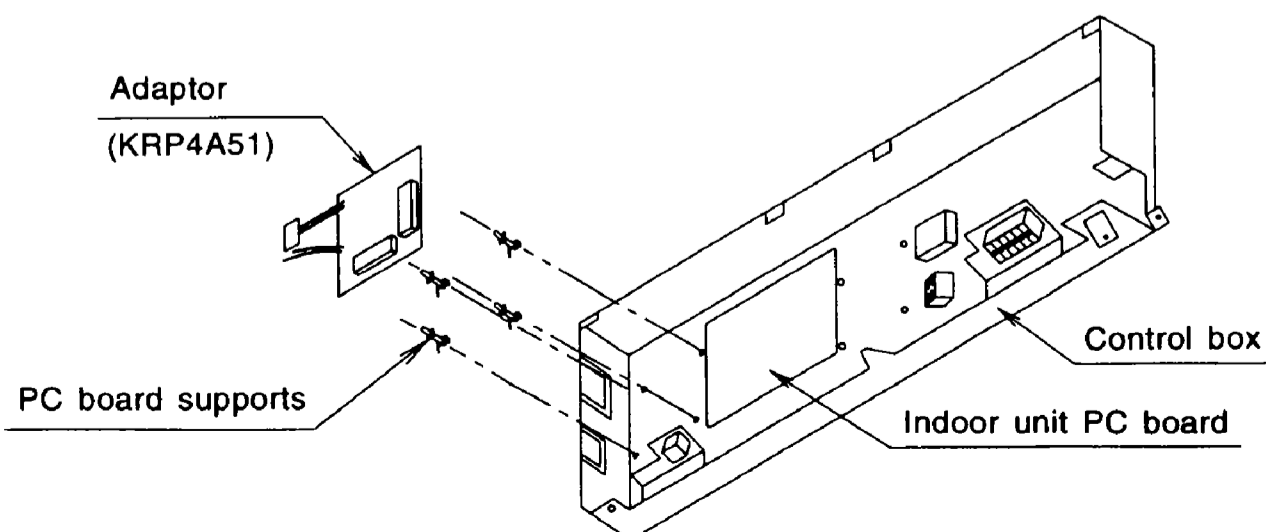


#### << Ceiling-suspended type >>

**FH(Y)**

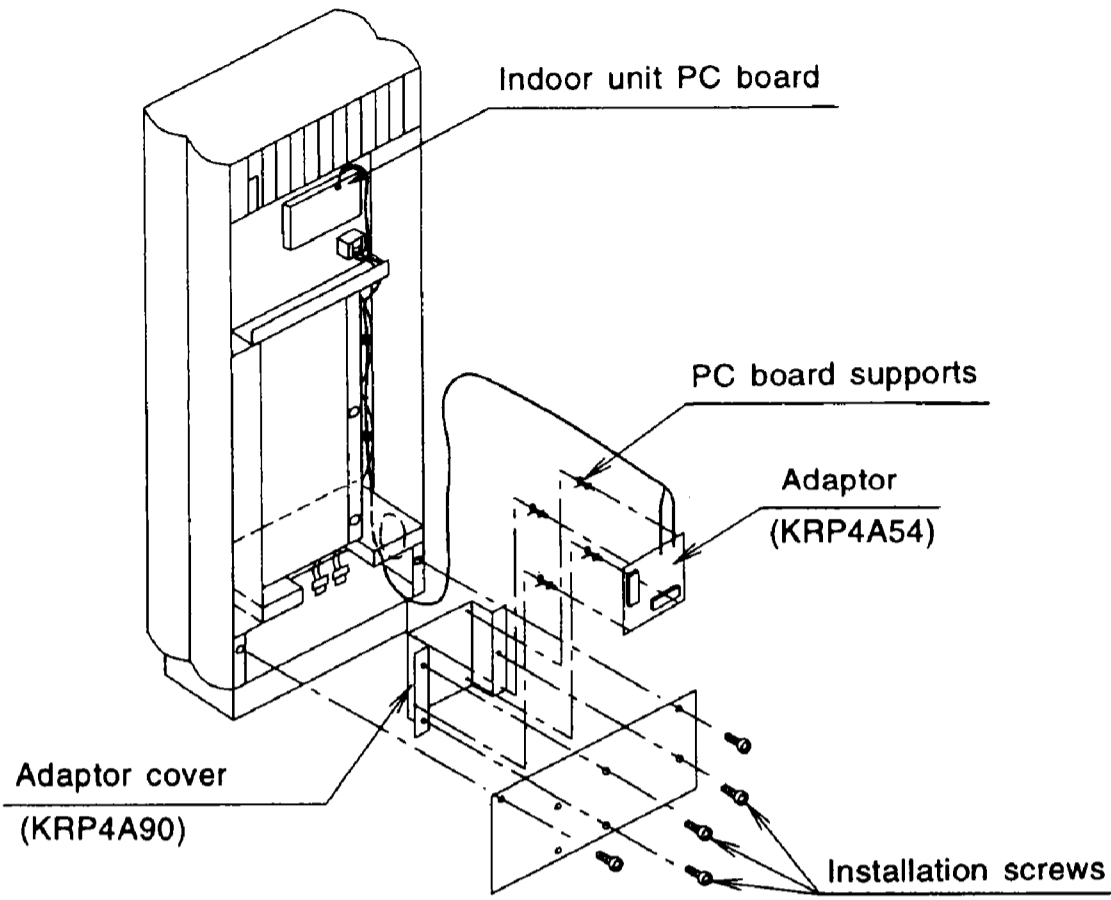


**FH(Y)K** (Corner type)



<< Floor-standing type >>

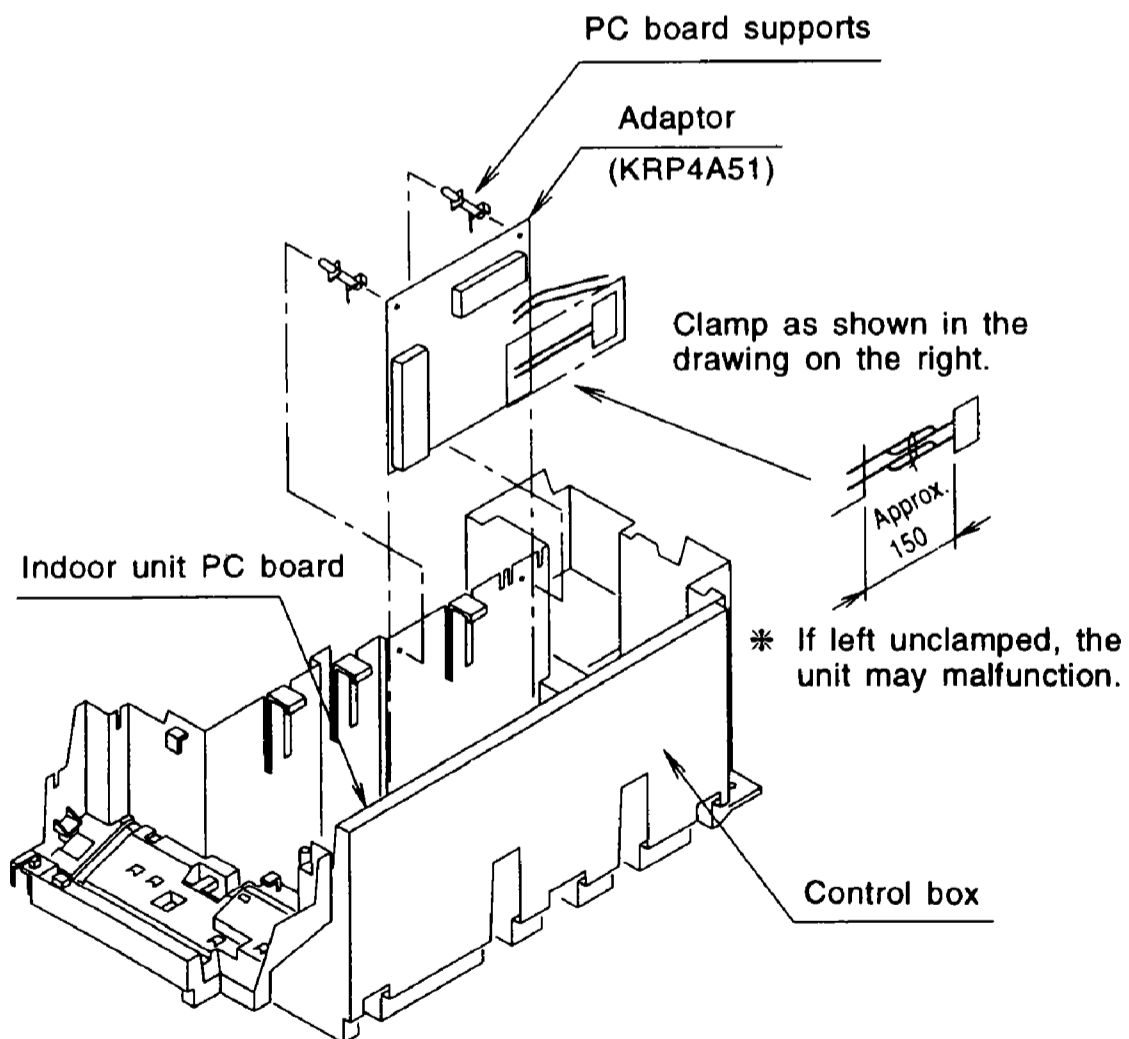
FVY



NOTE: Optional adaptor box is required to install the adaptor.

<< Wall-mounted type >>

FA(Y)

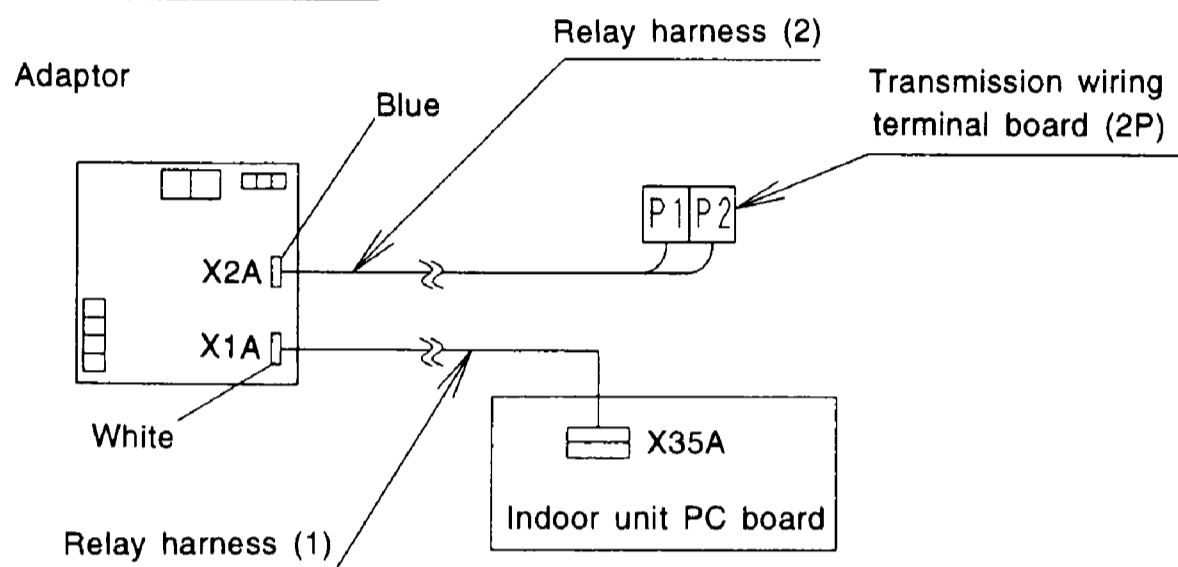




## 4 ELECTRIC WIRING

- ① First, wire between the indoor and outdoor units, and then to the separate power sources, and finally between the indoor units and the remote controllers. Then, check if they operate properly.  
(If wiring for group control by remote controller, check crosswires.)  
For details, see the installation manual of the indoor and outdoor units.
- ② Next, wire between outside units such as the central control monitor, etc. and make the necessary settings.  
For details, see Wiring to outside units (central control monitor)

### Wiring to indoor units



Make connections as shown above, using the attached relay harnesses (1) and (2).

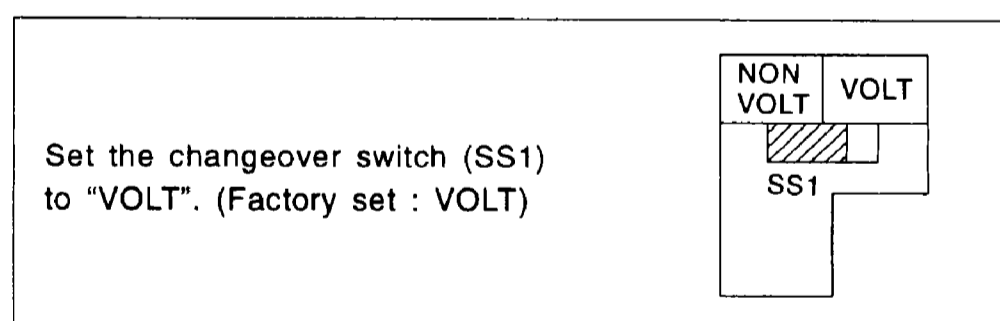
- Connect relay harness (1) to the connector (X35A) on the indoor unit PC board.
- Relay harness (2) has no polarity. Connect it to terminals P1 and P2 on the transmission wiring terminal board inside the indoor unit control box.

### Wiring to outside units (central control monitor)

#### 1. Remote control input (operation control)

Wire as described below. Wiring differs depending on whether using a voltage or no-voltage input.

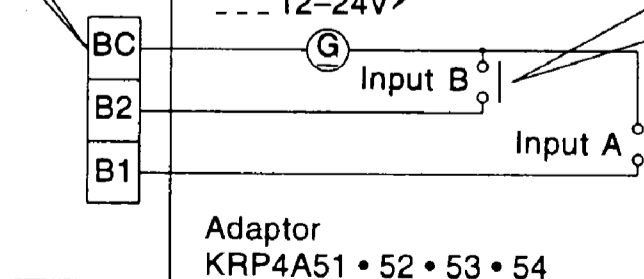
For voltage input



Connect the control input to the common contact (no polarity).

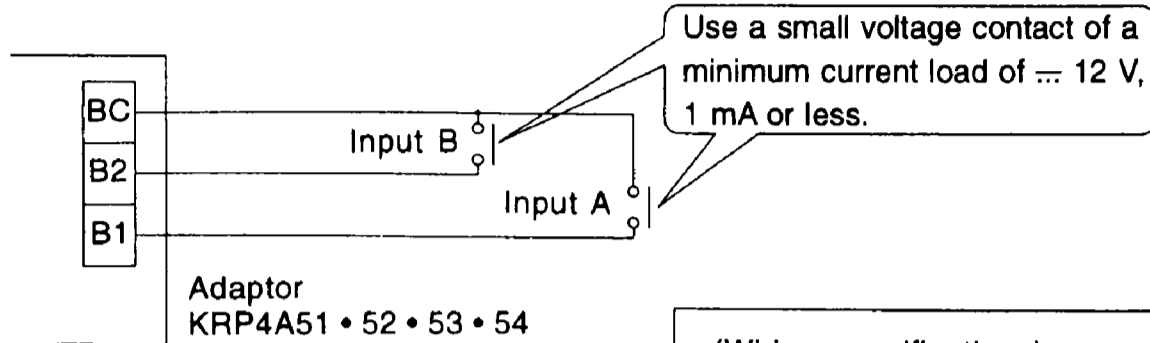
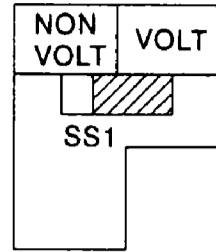
Use an external  $\approx 12 - 24$  V power supply. Each contact requires approximately 10 mA, therefore carefully select power supply capacity.

Use a small voltage contact of a minimum current load of  $\approx 12$  V, 1 mA or less.



For NON VOLT input

Set the changeover switch (SS1) to "NON VOLT".



Adaptor  
KRP4A51 • 52 • 53 • 54

(Wiring specifications)

Wiring ..... Sheathed vinyl cord or cable

Gauge ..... 0.18 ~ 1.25 mm<sup>2</sup>

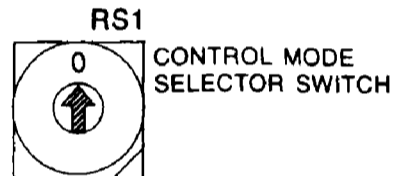
Length ..... Max. 150 m

< NOTE >

Keep transmission wiring away from power supply wiring to avoid malfunctions.

## 2. Setting the control mode selector switch (RS1)

Using the control mode selector switch (RS1), select the control mode as described below.



(Factory set)  
"0" position

### ① For specifying individual display

Position	Function
0	Individual display (input ignored)

### ② When operating the unit with constant input at input A

Position	Function	When input A is ON	When input A is OFF
1	ON/OFF control impossible by remote controller	Operation (normally ON/OFF control impossible by remote controller)	OFF + ON/OFF control impossible by remote controller
2	Centralized	Operation + ON/OFF control possible by remote controller	
3	OFF control possible by remote controller	Operation + OFF control possible by remote controller (ON control impossible by remote controller)	
4	ON/OFF control possible by remote controller	ON/OFF control possible by remote controller (Operation impossible by optional controller)	

< NOTE >

- Input B is for forced ON/OFF input. When input B is ON, OFF control is possible but ON/OFF control by the remote controller is impossible, and input A is ignored. When it is OFF, input A is ignored even if selected. It is necessary to reselect input A.

- ③ When operating the unit using instantaneous input at input A  
(Use an instantaneous input of 200 msec or longer ON time.)

Position	Function	Input A	Input B capacity
5	ON/OFF control impossible by remote controller	Turns OFF system with ON input Turns ON system with ON input	Input B is for forced OFF input (when ON, OFF control is possible but ON/OFF control by remote controller is impossible, and input A is ignored).
6	Individual	Turns OFF system with ON input Turns ON system with ON input (Normally ON/OFF control possible by remote controller)	

★ For thermostat control using input B

Position	When input A is ON	When input B is ON
C	ON/OFF control impossible by remote controller (Same as position 5)	Forced thermostat OFF command
D		Energy saving command
E	Individual (Same as position 6)	Forced thermostat OFF command
F		Energy saving command

- Forced thermostat OFF command  
Indoor unit fan only operates.
- Energy saving command  
The indoor unit operates at 2°C higher(cooling)/lower(heating) the set temperature.

( NOTE )

- In such case, even if input A is ON, thermostat control is turned OFF, and all units in the same group will stop.

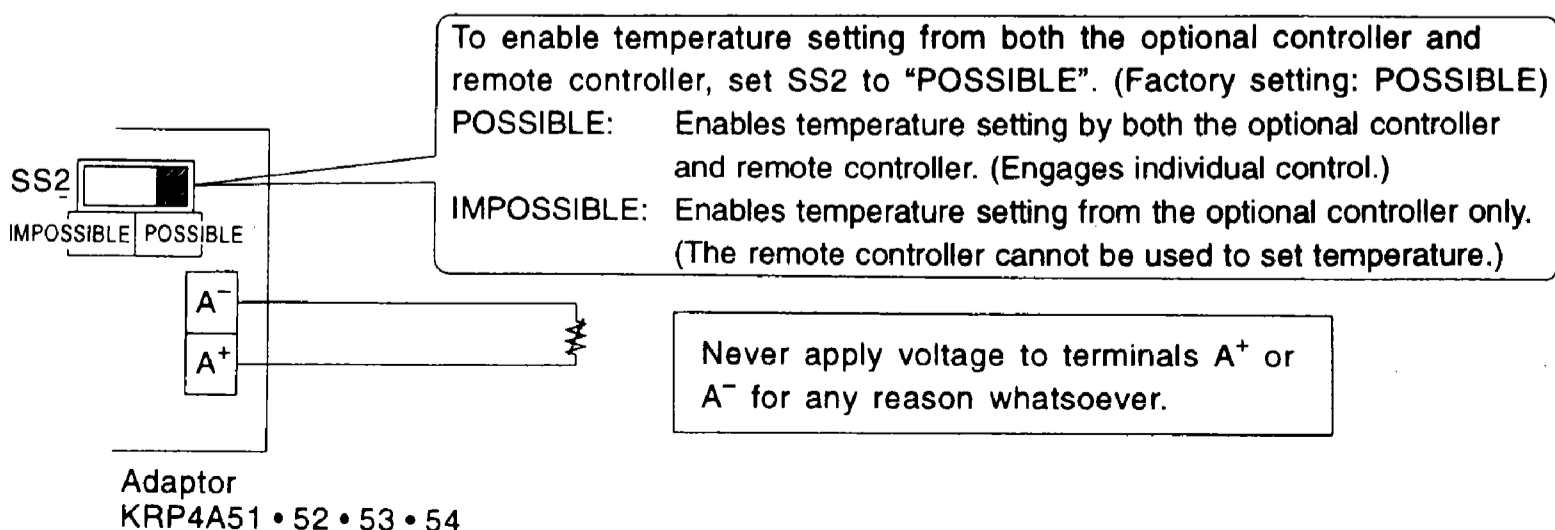
- ④ When operating the unit using instantaneous input at input A and B  
(Use an instantaneous input of 200 msec or longer ON time).

Position	Function	When input A is ON	When input A is OFF
7	ON/OFF control impossible by remote controller	Operation (normally ON/OFF control impossible by remote controller)	OFF + ON/OFF control impossible by remote controller
8	Centralized	Operation + ON/OFF control possible by remote controller	
9	OFF control possible by remote controller	Operation + OFF control possible by remote controller (ON control impossible by remote controller)	
A	ON/OFF control possible by remote controller	ON/OFF control possible by remote controller (Operation impossible by optional controller)	
B	Individual	Operation (normally ON/OFF control possible by remote controller)	OFF (normally ON/OFF control possible by remote controller)

( NOTE )

- When set to position 7-A, and using the constant mode for input B, forced stop capacity is enabled (input A is ignored).
- At position B, the constant mode for input B is not used.

### 3. Temperature setting input



Temperature setting corresponds to resistance values in the range of 0 to 135Ω as shown below.

Temperature setting (°C)	16	17	18	19	20	21	22	23	24
Resistance (Ω)	0.0	5.0	13.8	22.4	31.0	39.4	48.2	56.6	65.2
	3.4	11.6	20.0	28.4	36.4	44.8	52.8	61.2	69.4

Temperature setting (°C)	25	26	27	28	29	30	31	32
Resistance (Ω)	73.8	82.4	91.0	99.4	108.6	117.2	125.8	134.2
	77.8	85.8	94.0	102.2	110.4	119.2	127.4	140.0

NOTE: Line resistance included in above figures.

(Wiring specifications) Wiring ..... Sheathed vinyl cord Gauge ..... 1.25 ~ 2.00 mm <sup>2</sup> Length ..... Max. 70 m	( NOTE ) Keep transmission wiring away from power supply wiring to avoid malfunctions.
--	---

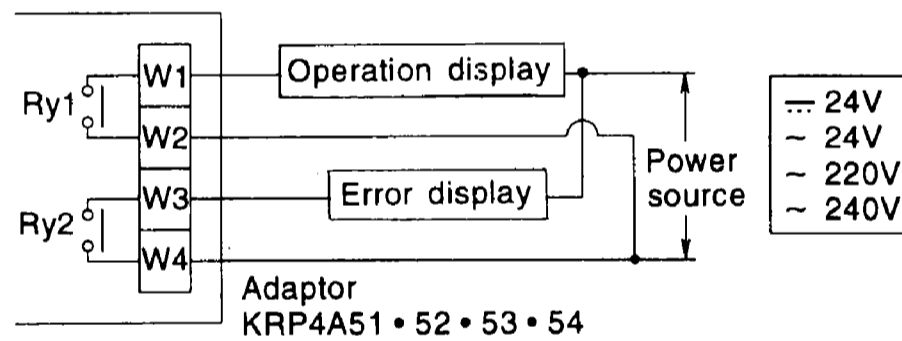
#### 4. Canceling display signals

Operation output terminals (W1 and W2) and error output terminals (W3 and W4) are no-voltage normally constant contacts.

(Allowed electric current per contact is between 10 mA and 3 A.)

Normal operation output (Ry1)  
ON when the indoor unit is operating normally.

Error output (Ry2)  
ON when the indoor unit stops because of malfunction or when a transmission error occurs between the adaptor and the indoor unit.



( NOTE )  
If using a 220 or 240 V power supply, keep transmission wires away from incoming power supply wiring.

Display output is as described below.

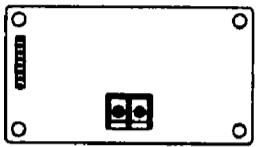

Output	Both Ry1 and Ry2 OFF	Only Ry1 ON	Only Ry2 ON
Display	OFF	Normal operation	System stopped due to malfunction or transmission error generated between adaptor and indoor unit

# 7 Interface adaptor for Sky Air Series

## DTA102A52

### Accessories

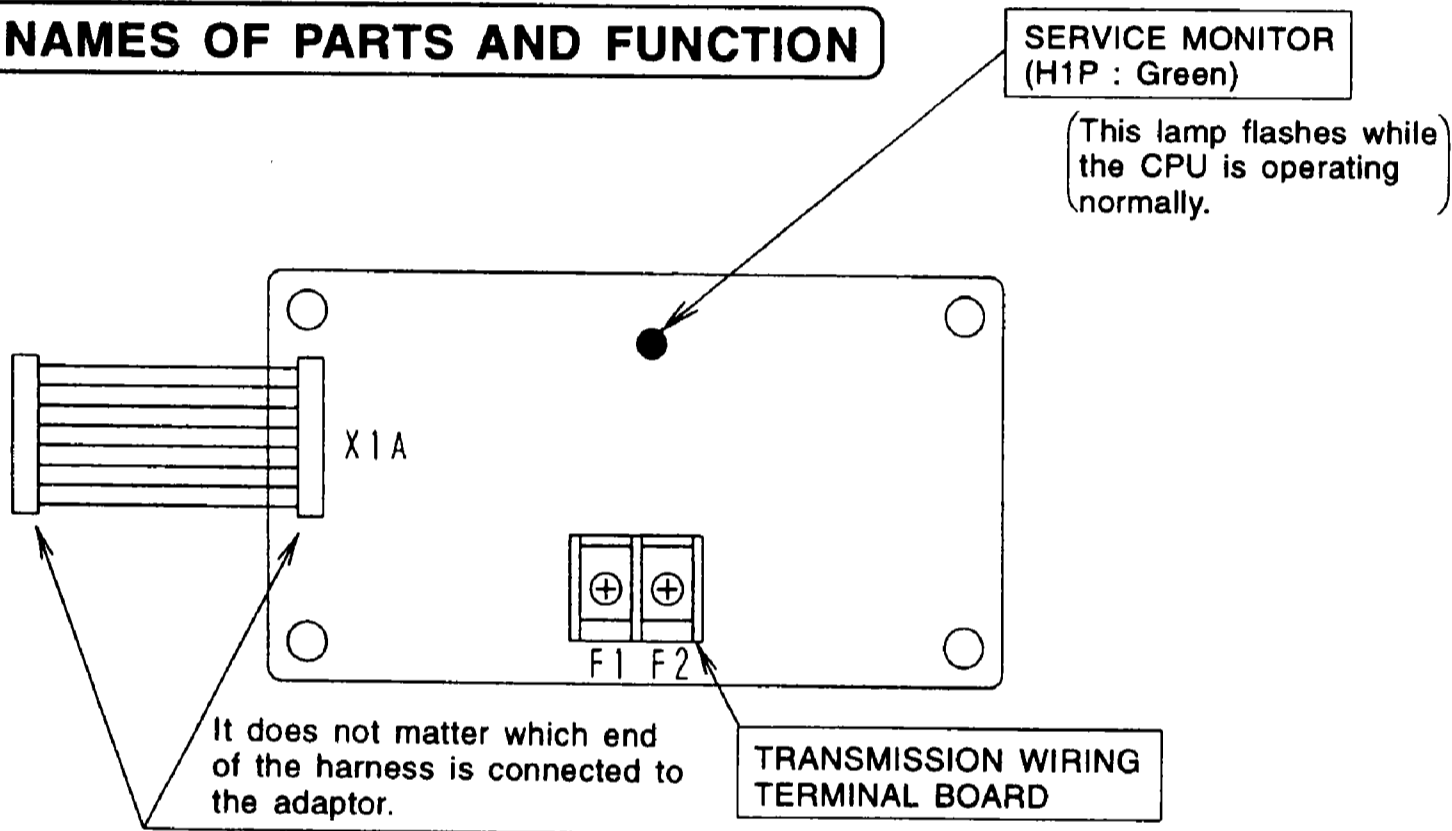
Check if the following accessories are included in the kit.

Adaptor x 1	Relay harness x 1	PC board support x 4
		Tie wrap x 2
		Installation manual x 1

### 1 SYSTEM OUTLINE

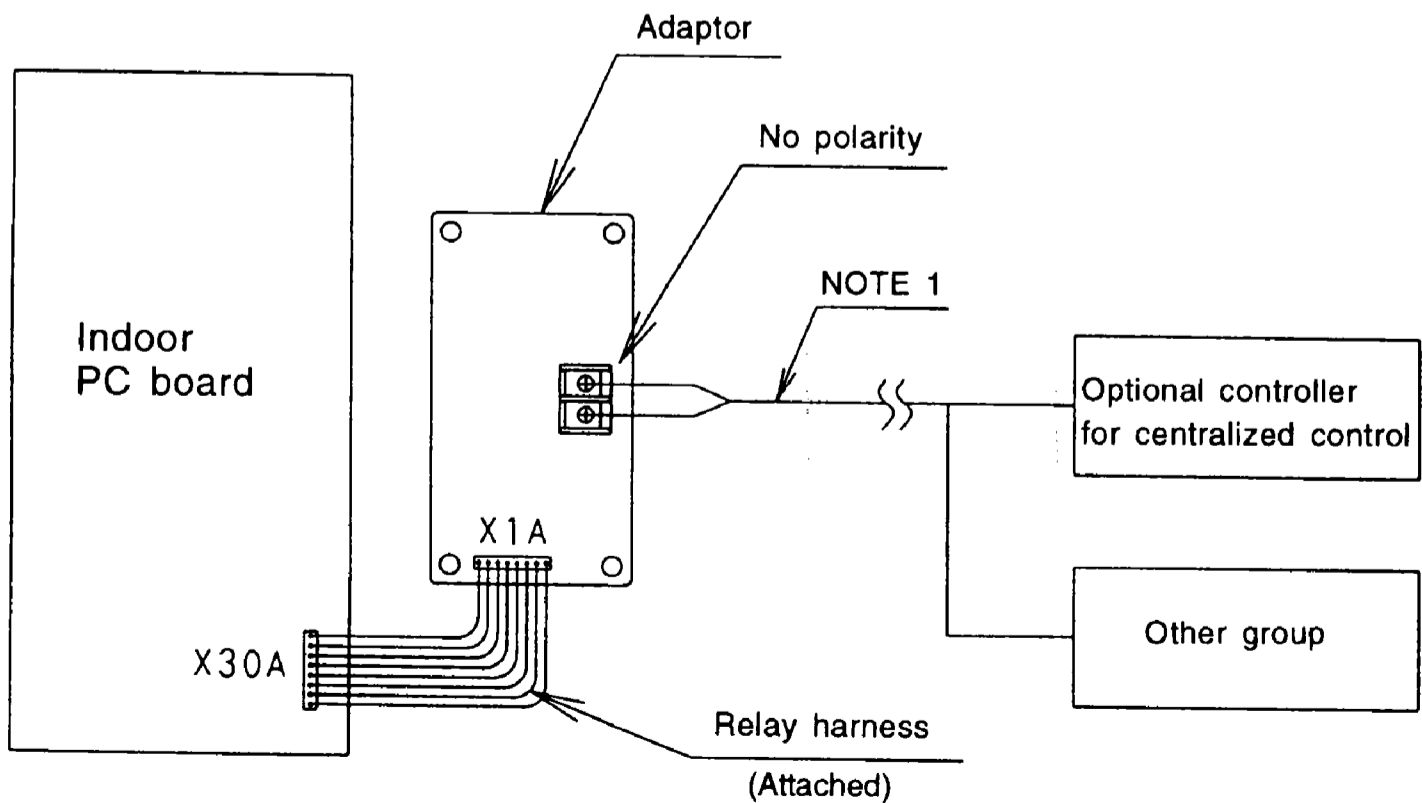
- By connecting this kit to an optional controller for centralized control, all units of the SKY AIR Series in the system can be controlled as a group from the optional controller.
- One kit must be installed onto the master unit of each group.

### 2 NAMES OF PARTS AND FUNCTION



### 3 ELECTRIC WIRING

- Wire this kit as described below.
- Make sure wires to units do not pass over the PC board when wiring.



NOTE 1. Wiring specifications . . . Use a 0.75 – 1.25 mm<sup>2</sup> sheathed vinyl cord or cable (2 wire).  
 2. For details on compatible systems and how to connect to optional controllers, see the instruction manual of the optional controller and technical reference materials.

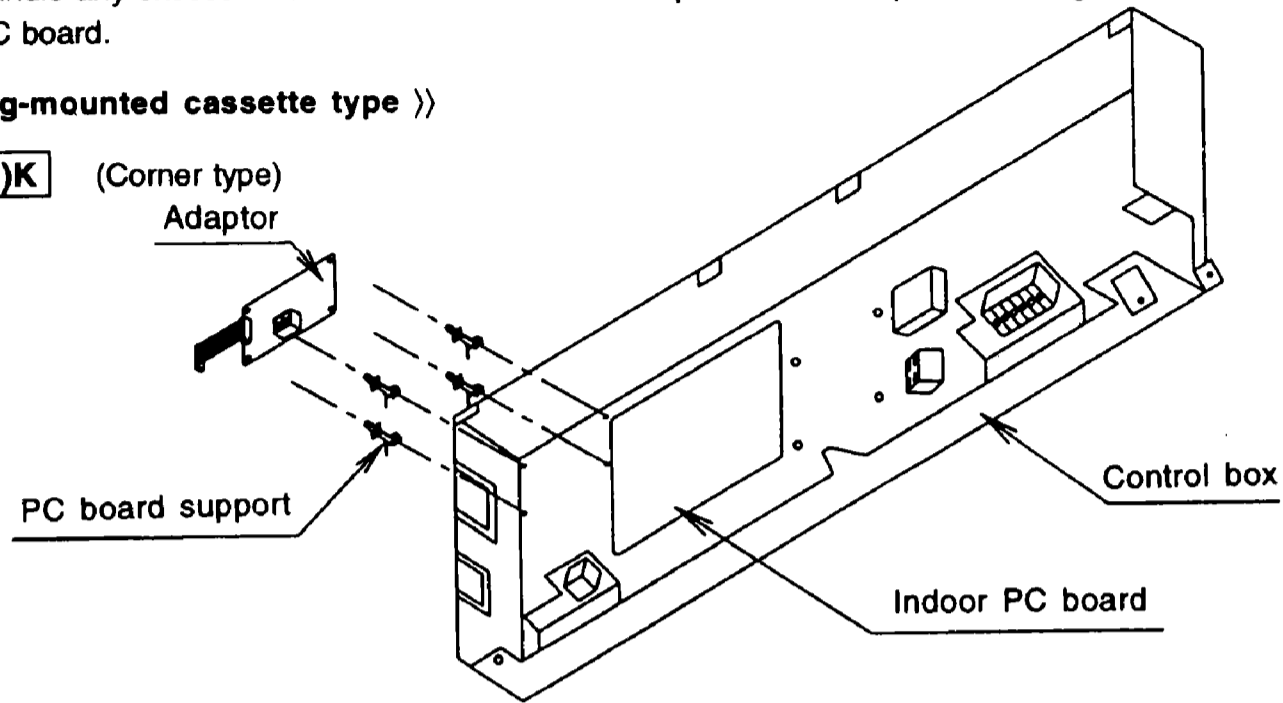
## 4 INSTALLATION

- Installation differs according to models as shown below.
- Do not bundle low and high voltage wires together.
- Bundle any excess wires with the attached tie wraps so as to keep loose wirings off the indoor unit PC board.

### << Ceiling-mounted cassette type >>

**FH(Y)K**

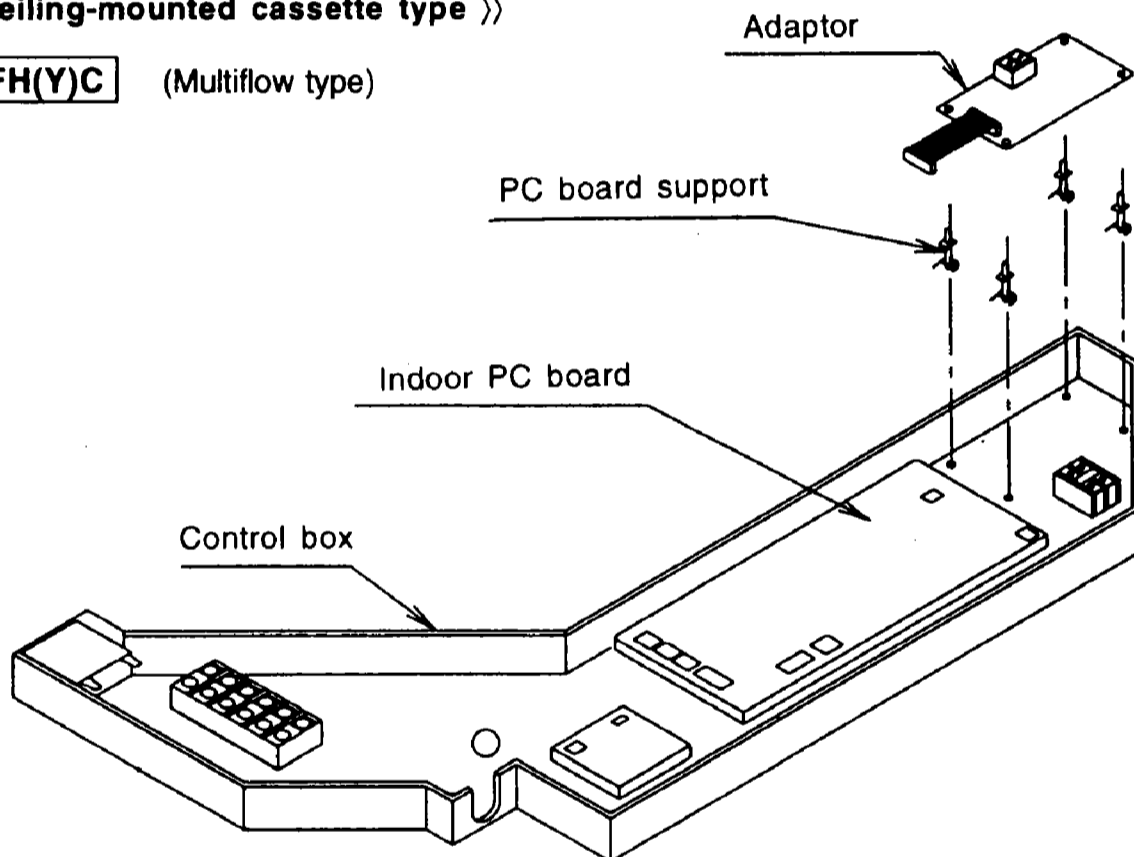
(Corner type)



### << Ceiling-mounted cassette type >>

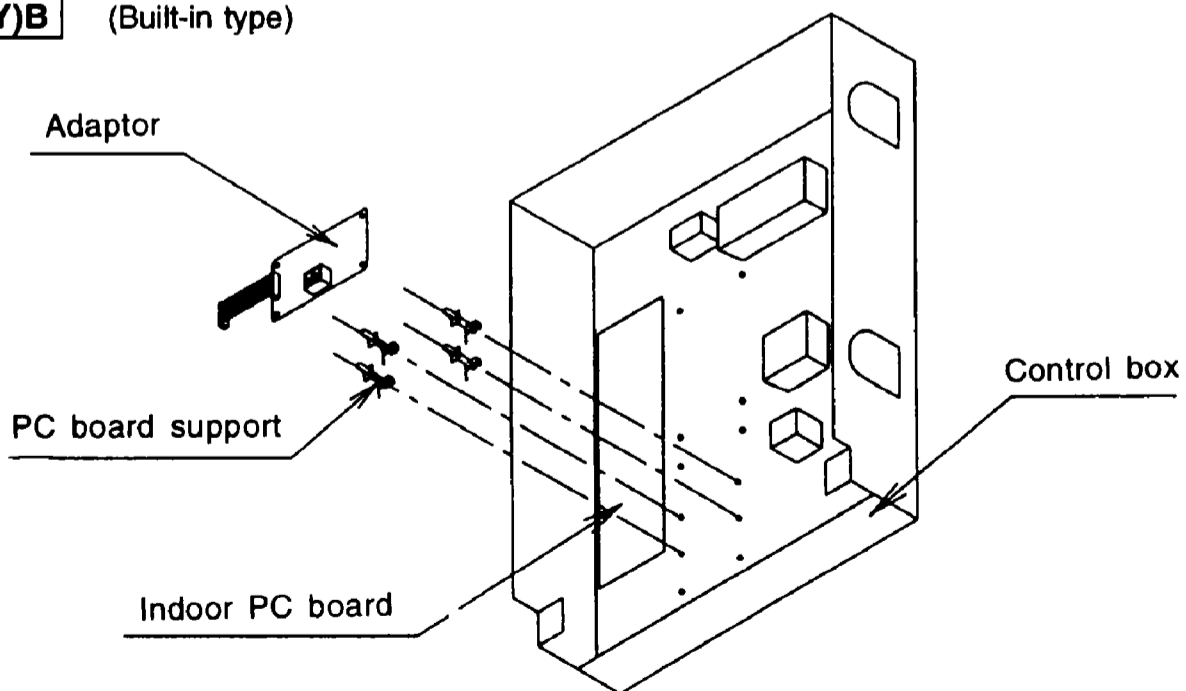
**FH(Y)C**

(Multiflow type)



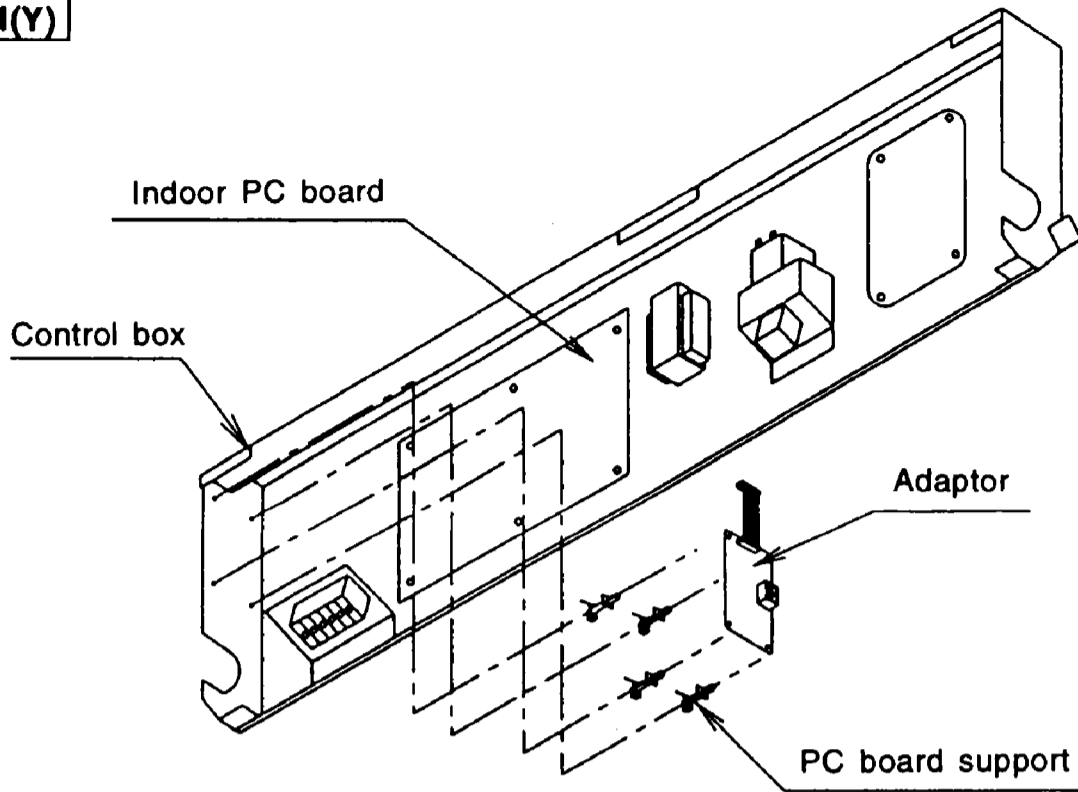
**FH(Y)B**

(Built-in type)



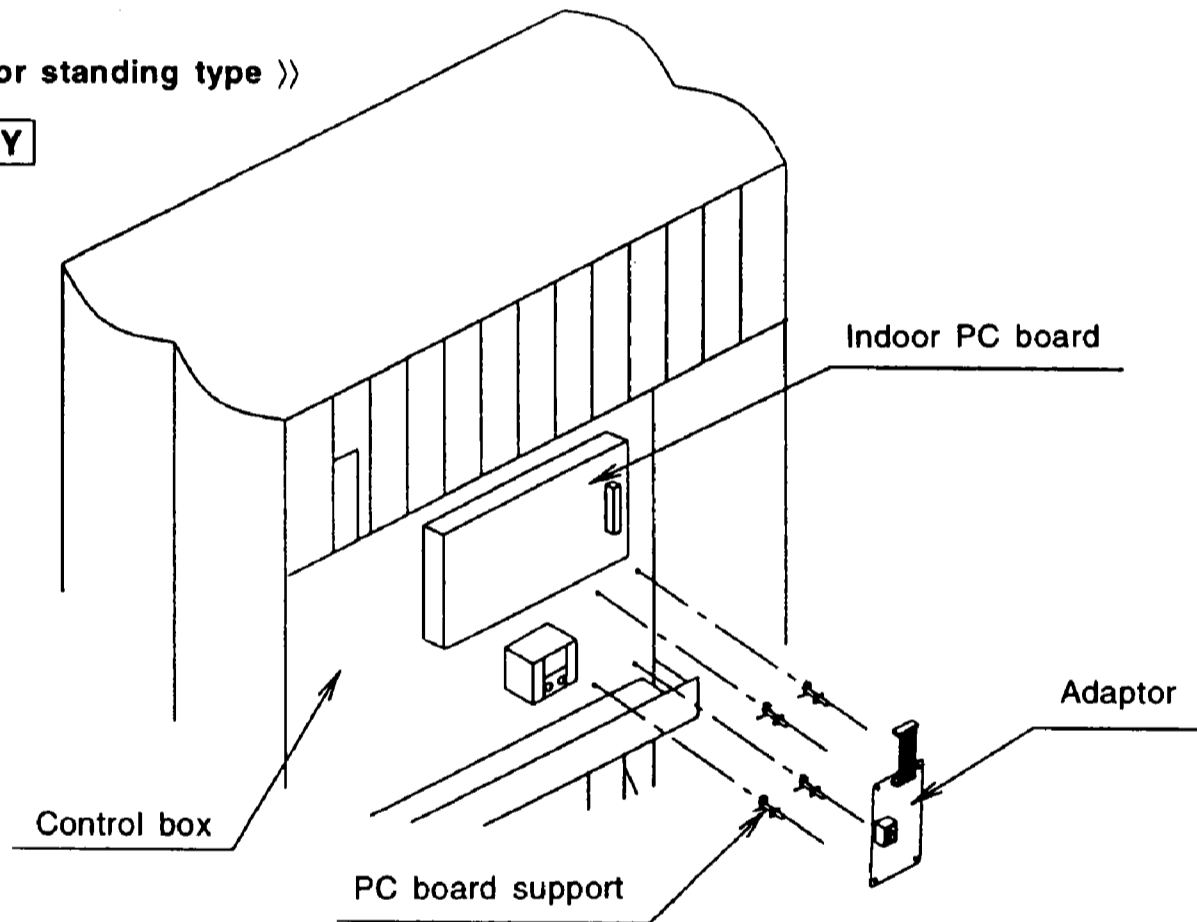
« Ceiling suspended type »

FH(Y)



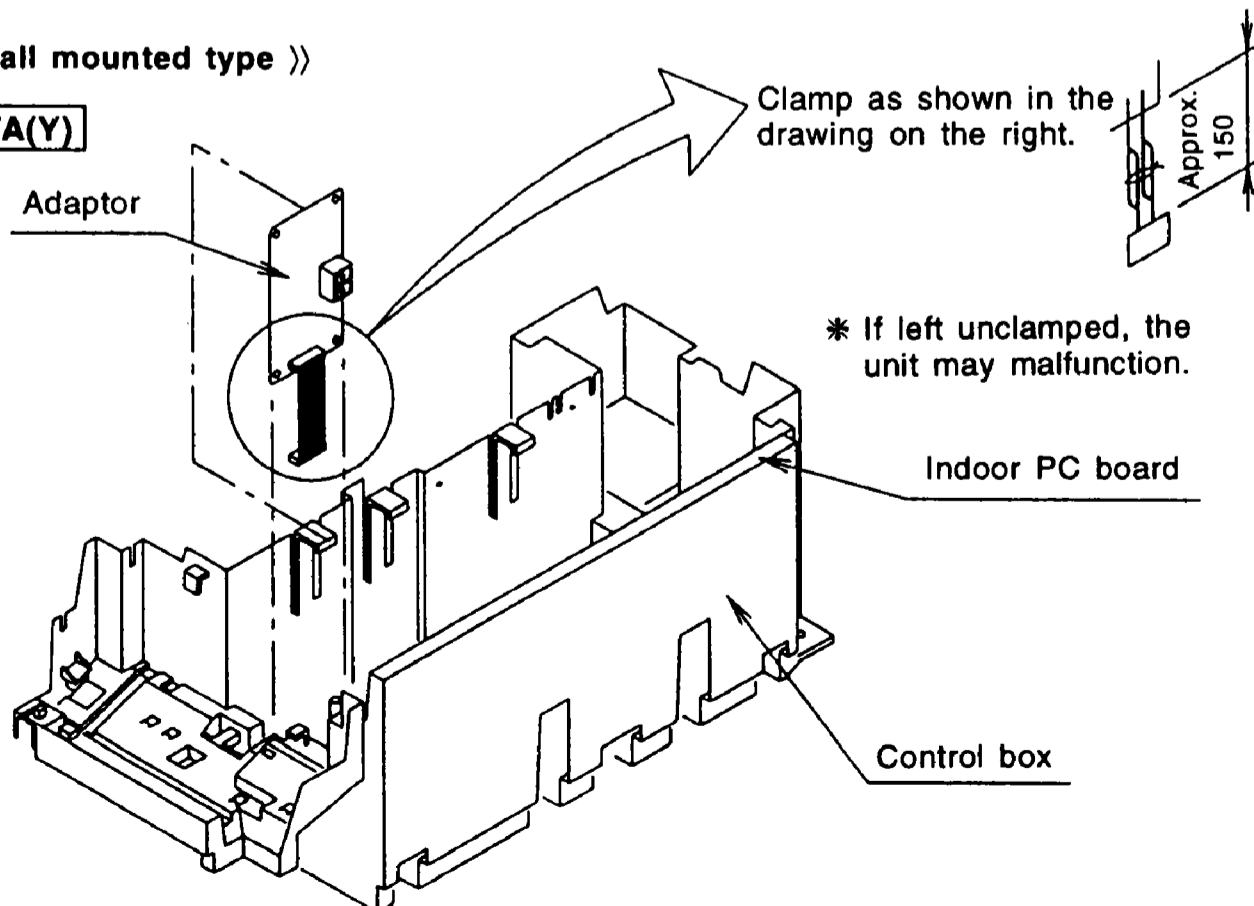
« Floor standing type »

FVY



« Wall mounted type »

FA(Y)



## 8 Ceiling mounted cassette type [FH(Y)C]

### 8.1 Decoration panel – BYC71F-W1·125F-W1

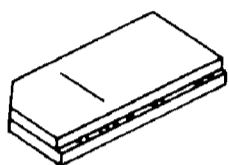
## BEFORE INSTALLATION

### PRECAUTIONS

- Refer also to the installation manual attached to the indoor unit.

### ACCESSORIES

- Blocking pad is only attached to BYC71F-W1 model.  
(It is not attached to BYC125F-W1 model.)



Blocking pad x 1

### NOTE TO INSTALLER

Be sure to instruct the customer how to properly operate the system showing him/her the attached operation manual.

## PREPARATION OF DECORATION PANEL

⟨⟨ For this unit, you are able to select air flow directions. To discharge air in 2 or 3 directions, it is necessary to purchase optional blocking pad kit. ⟩⟩

### HANDLING OF DECORATION PANELS

- Never place the panel facing down nor lean it against a wall nor leave it on a projecting object.
- Never touch or put pressure on the swing flap.  
(The swing flap may malfunction)

(1) Remove the suction grille from the decoration panel.

- ① Slide the suction grille lever inward and lift up the lever side.  
(Refer to Fig. 1)

- ② Detach the suction grille from the decoration panel by lifting the grille up approximately 45 degrees.  
Peel off the air filter fixing tape on the back of the suction grille after detachment. (Refer to Fig. 2)

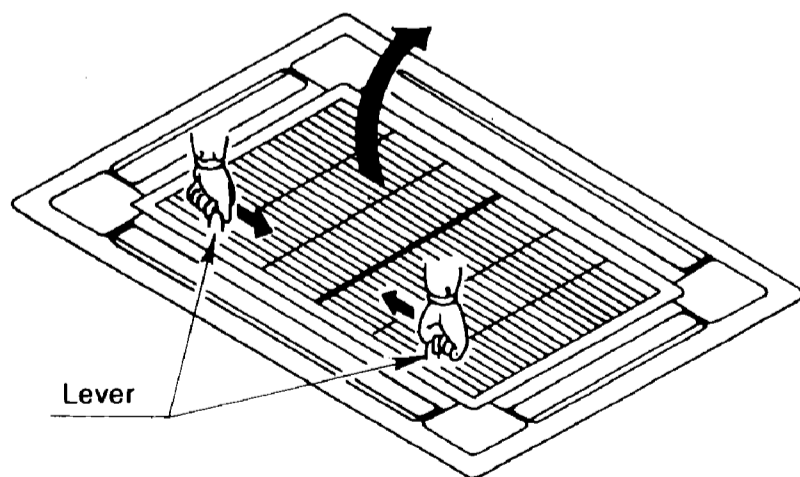


Fig. 1

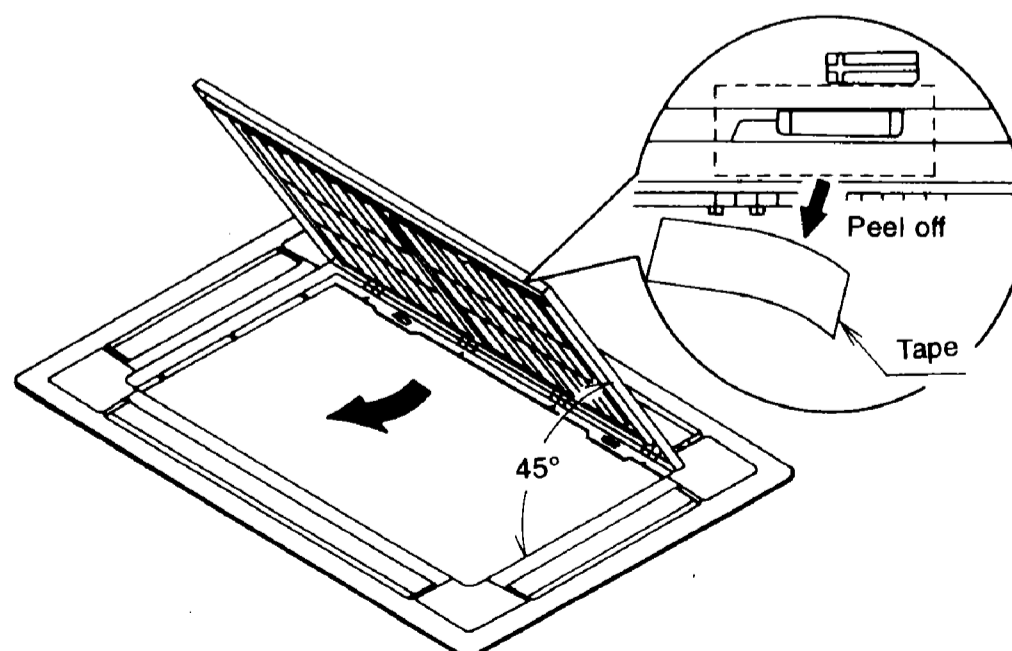


Fig. 2

BYC71F-W1: 2 positions  
BYC125F-W1: 4 positions



- (2) Remove the service cover on the corner.

Detach the tape used for fixing the cover and slide the service cover outward to remove. (Refer to Fig. 3)

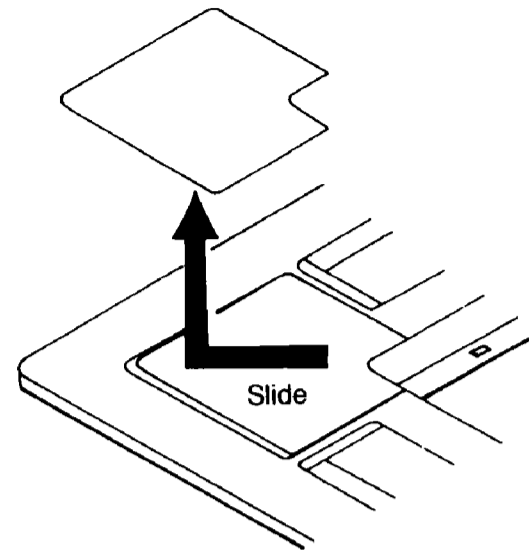


Fig. 3

## INSTALLATION ON HIGH CEILING

- (1) This panel can be installed on a ceiling up to 3.5 m height. However, installation on a ceiling higher than 2.7 m requires setting change of the indoor unit. In this case, perform setting with the remote controller according to the ceiling height of the installation site.

For setting, refer to the "INITIAL SETTING" attached to the remote controller.

- (2) In case of BYC71F-W1 model, install the attached blocking pad. (It is not needed for BYC125F-W1 model.)

- ① Cut the blocking pad along the slit. (Refer to Fig. 4)

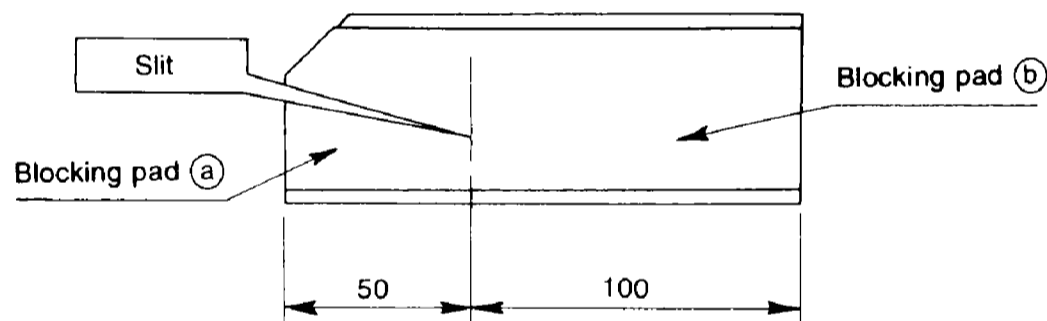


Fig. 4

- ② Install the blocking pad

Refer to Fig. 5 for installing the blocking pad.

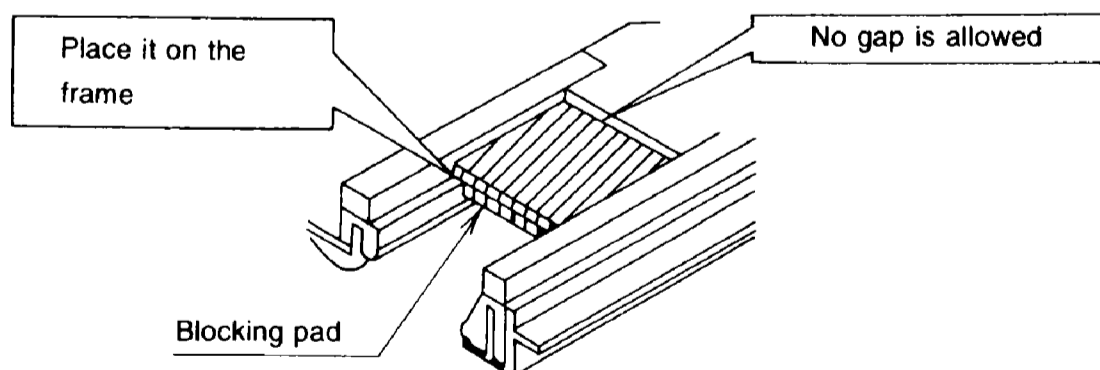
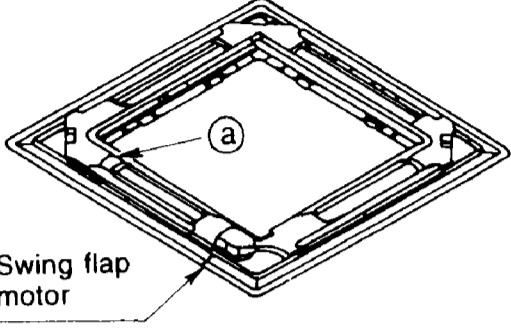
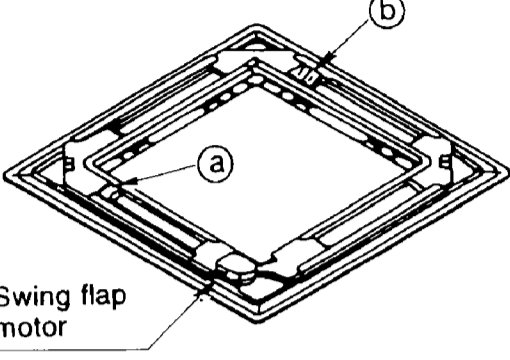


Fig. 5

Refer to Table 1 for installation locations of the blocking pad.

Table 1

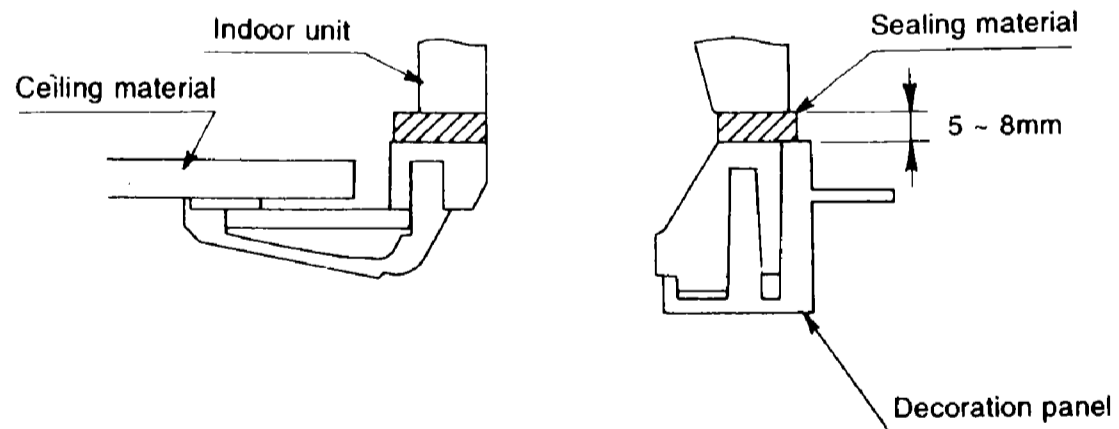
Ceiling height	~ 2.7m	2.7 ~ 3m	3 ~ 3.5m
Installation location of the blocking pad	No need to install the attached blocking pad.	 <p>Install the blocking pad to one part</p>	 <p>Install the blocking pad to two parts.</p>

(3) If you are installing the optional blocking pad kit (2 or 3 air flow directions), install at this point.  
Refer to the instruction manual attached to the blocking pad kit for installation.

## INSTALLATION OF THE DECORATION PANEL TO THE INDOOR UNIT BODY

⟨⟨ Refer to the installation manual attached to the indoor unit for the installation of the indoor unit. ⟩⟩

- (1) Set the decoration panel to the indoor unit body by matching the position of the swing flap motor of the decoration panel to the piping position of the indoor unit as shown in Fig. 6.
- (2) Install the decoration panel
  - ① Temporarily install the decoration panel to the indoor unit by hanging the latch on the opposite side of the swing flap motor of the decoration panel to the hook of the indoor unit body. (2 positions)
  - ② Temporarily hang the remaining 2 latches to the hooks on the sides of the indoor unit.  
(Be careful not to let the swing motor lead wire get caught in the sealing material.)
  - ③ Screw all 4 hexagon head screws located right beneath the latches in approximately 15 mm. (Panel will rise)
  - ④ Adjust the decoration panel by turning it to the arrowed direction in Fig. 6 so that the ceiling opening is completely covered.
  - ⑤ Tighten the screws until the thickness of the sealing material between the decoration panel and the indoor unit body reduces to 5-8 mm.



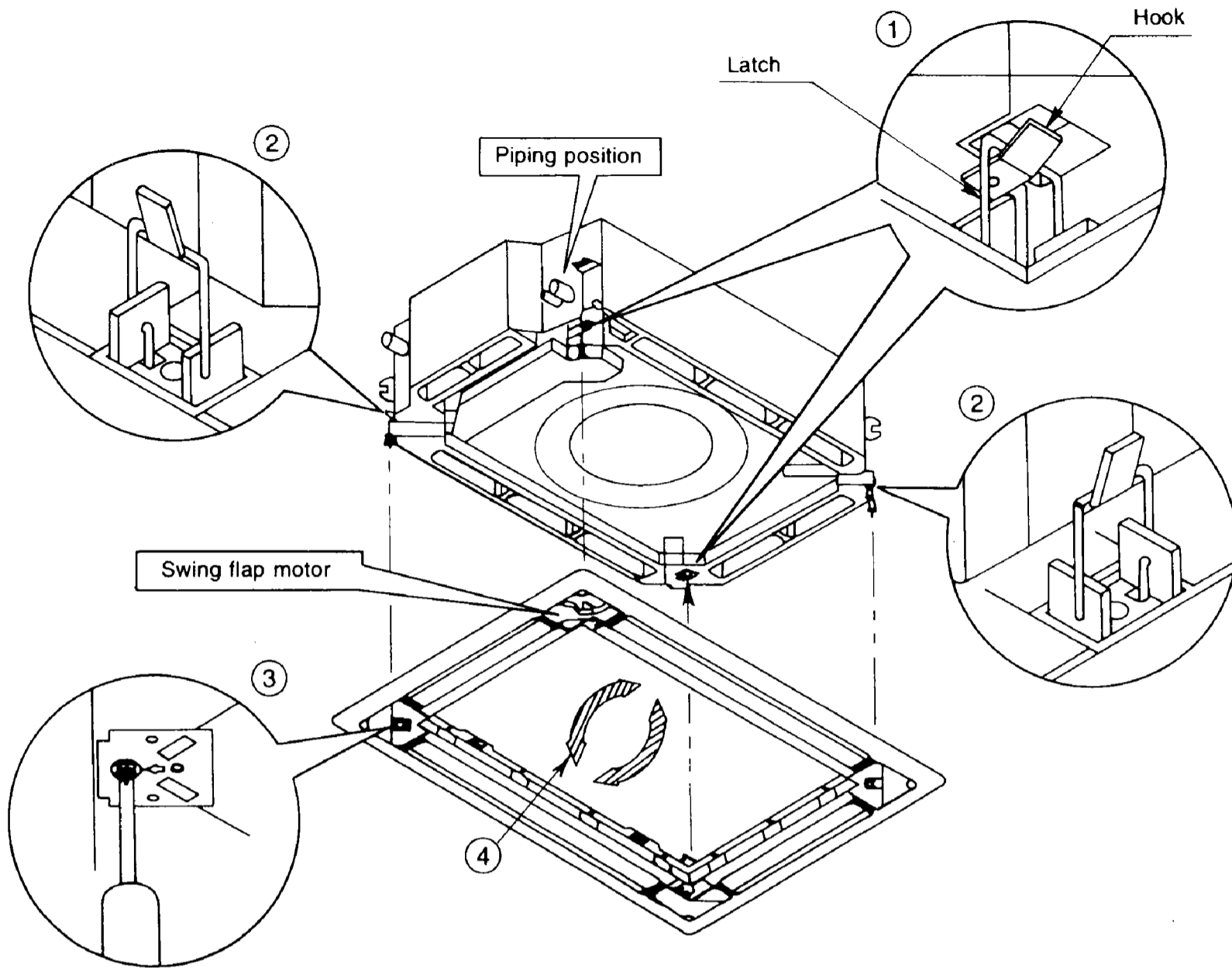


Fig. 6

**PRECAUTIONS**

- Improper screwing of the screws may cause the troubles shown in Fig. 7. Screw properly.

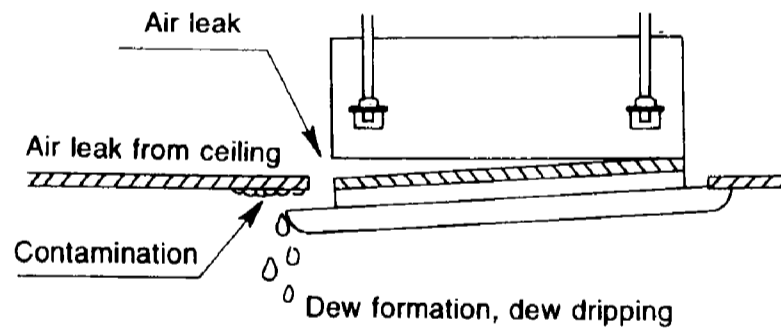


Fig. 7

- If gap is still left between the ceiling and the decoration panel after screwing the screws, readjust the indoor unit body height. (Refer to Fig. 8)

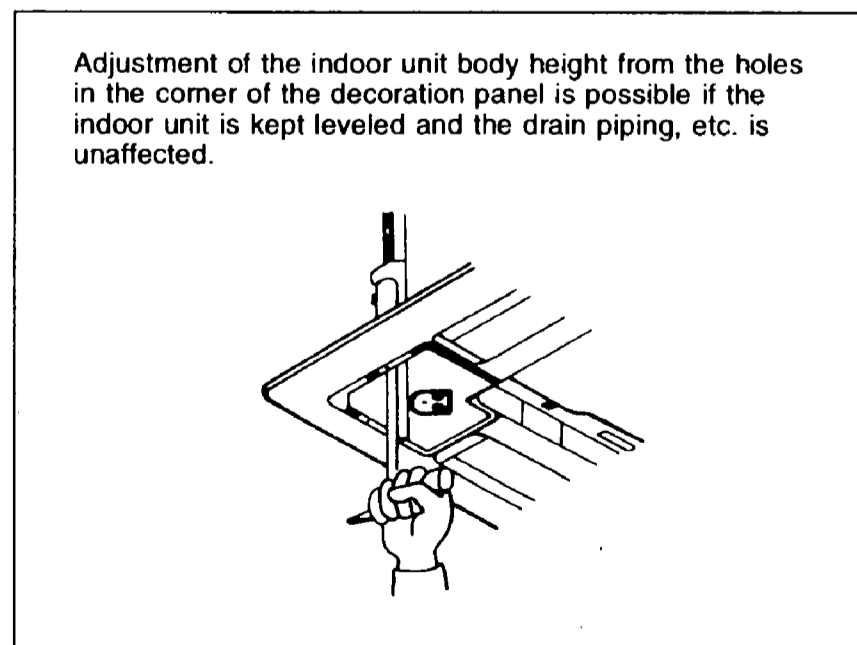
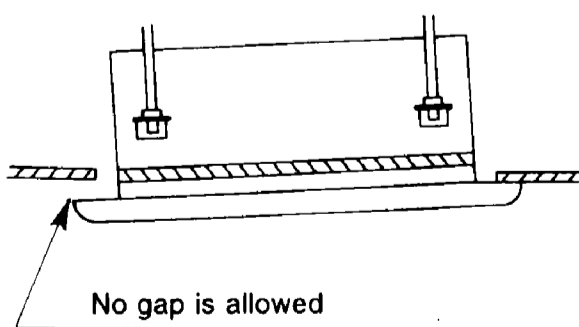


Fig. 8

(3) Wiring of the decoration panel (Refer to Fig. 9)

- ⑥ Connect the connectors for swing flap motor lead wire (at 2 places) installed on the decoration panel.

If connectors are not connected, the malfunction display (A7) appears on the remote controller.  
Connect the connectors properly.

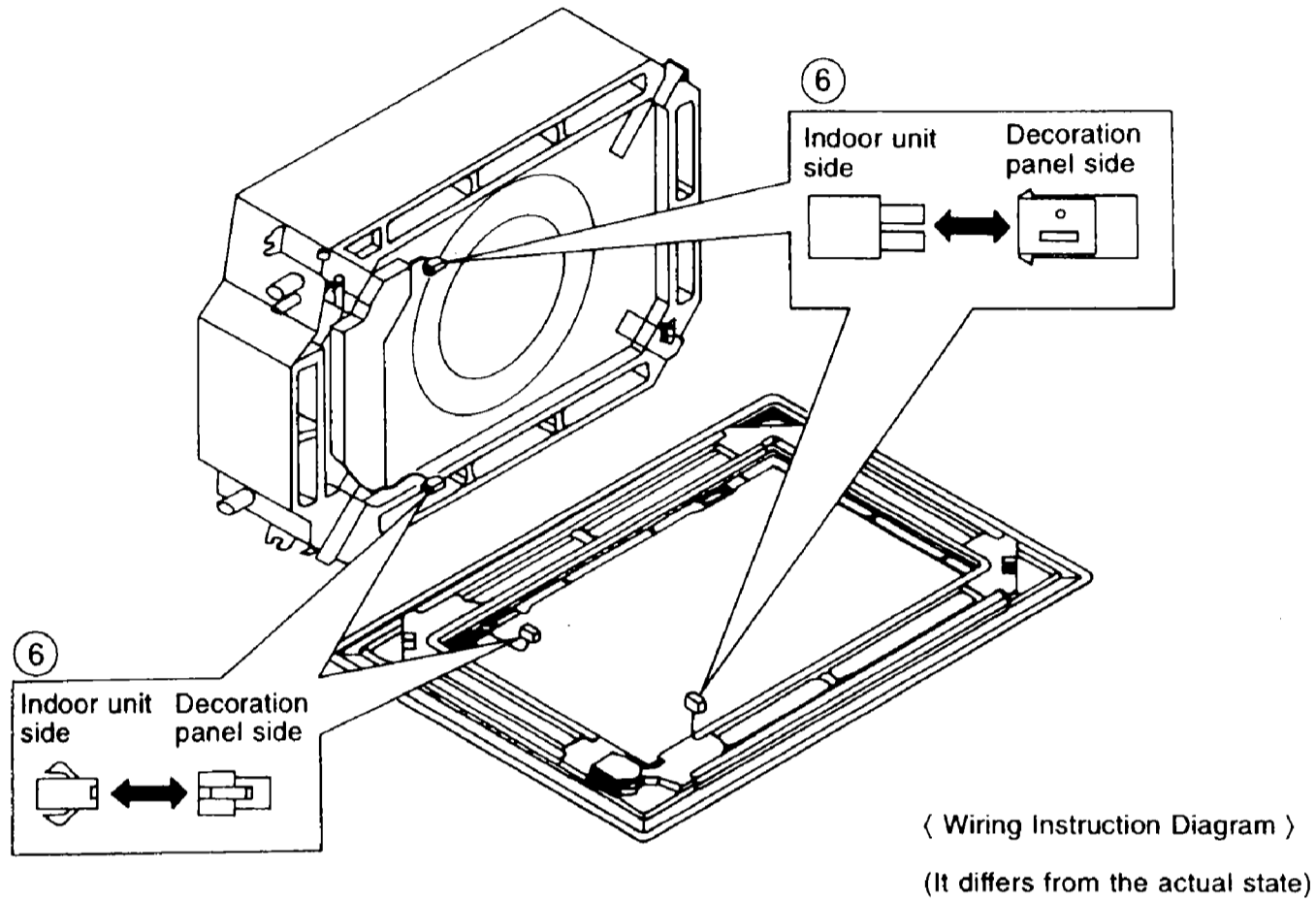


Fig. 9

## INSTALLATION OF SUCTION GRILLE AND SERVICE COVER

(1) Install the suction grille

Install by reversing the procedure shown in "PREPARATION OF DECORATION PANEL".

In the case of BYC71F-W1, it is possible to install the suction grille in 4 directions by turning the suction grille.

Change the direction when adjusting the direction of the suction grille of multiple units or in meeting customers' demands.

**NOTE)**

Be careful not to get swing flap motor lead wire get caught when installing the suction grille.

(2) Install the service cover on the corner.

- ① Attach the string of the service cover to the pin of the decoration panel as in Fig. 10.

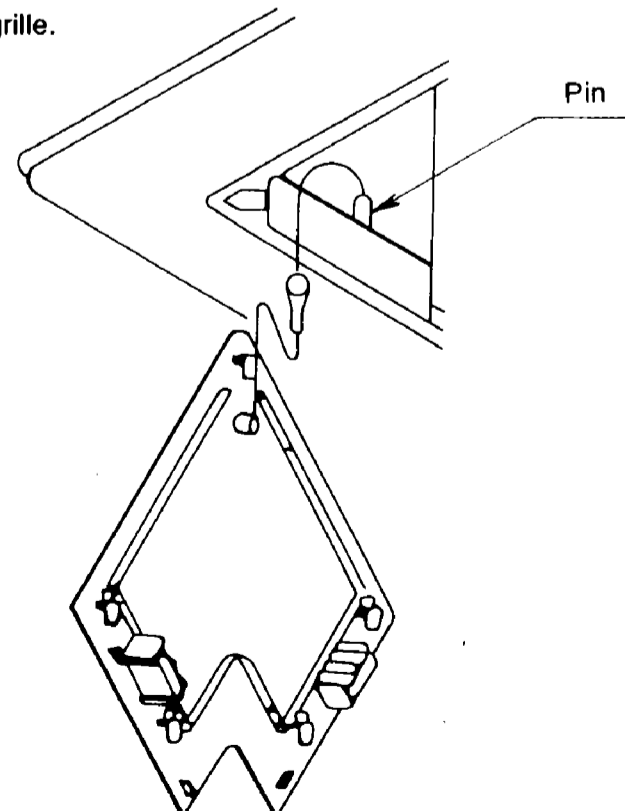
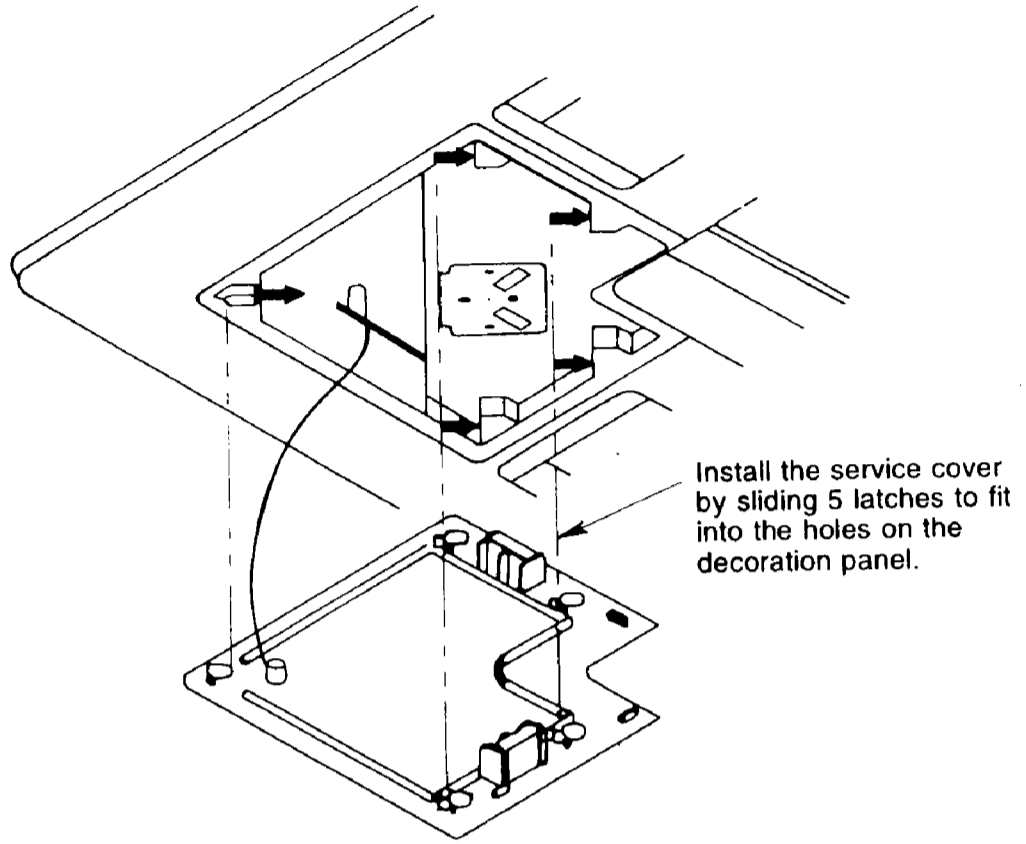


Fig. 10

- ② Install the service cover over the decoration panel.



## 8.2 Sealing member of air discharge outlet – KDBHJ55F80-160

### ● Specifications

Model name	KDBHJ55F80	KDBHJ55F160
Item		
Decoration panel	BYC71F(J)-W1	BYC125F(J)-W1
Applicable model	For indoor unit 35F~71F	For indoor unit 100F~125F

● Refer to the "installation guide" for details.

### Caution

- Refer to the installation manual for both indoor unit and the decoration panel.
- When you install other optional kit, it may not be possible to select the 3-way or 2-way air discharge. For details, refer to the manual for the optional kit or the catalogue.

Optional kit	4-way air discharge	3-way air discharge	2-way air discharge
High efficiency filter chamber	○	✕ Not possible to install	✕ Not possible to install
Panel spacer	○	○	✕ Not possible to install

● **Contents of Kit** Prior to installation check to make sure you have the complete kit of parts.

Name	Sealing member (A)	Sealing member (A1)	Sealing member (A2)	Sealing member (B)	Sealing member (B1)	Sealing member (B2)	Sealing member (C)	Sealing member (D)	Sealing member (b)	
Quantity	KDBHJ55F80	1 piece	—	—	1 piece	—	—	1 piece	1 piece	1 piece
	KDBHJ55F160	—	1 piece	1 piece	—	1 piece	1 piece	1 piece	1 piece	1 piece
Shape and marking										

Name	Seal	Insulation for suspension hanger	Moisture absorber for bell-mouth	Insulation for side plate	Insulation for piping	Insulation for electrical box	Moisture absorber for panel				
Quantity	KDBHJ55F80	5 pieces	4 pieces each	—	1 piece	—	3 pieces	1 piece	1 piece	4 pieces	1 pieces
	KDBHJ55F160	6 pieces	4 pieces each	1 pieces each	1 piece	2 pieces	1 piece	1 piece	1 piece	4 pieces	1 pieces
Shape and marking											

### ① Selection of the direction of air discharge and the positioning of sealing member

#### (1) Selection of air outlet

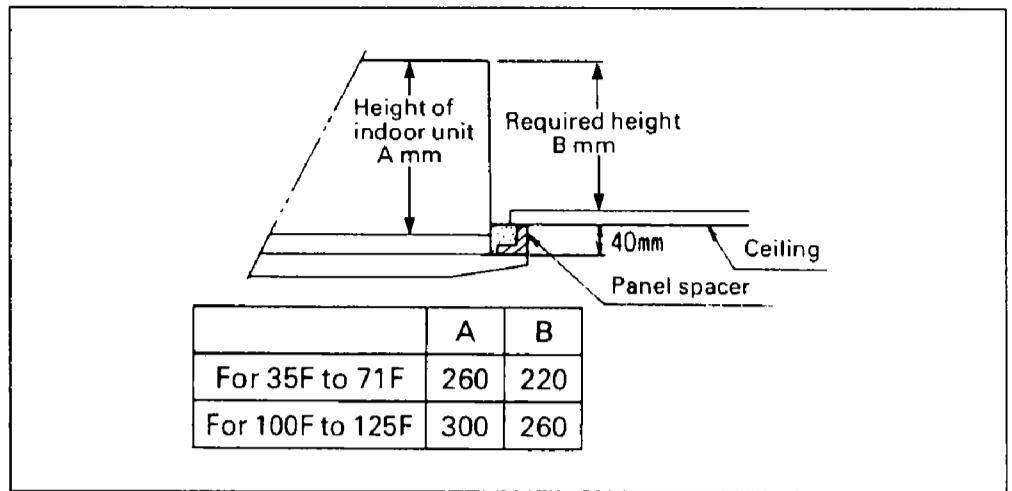
Select the direction of air discharge from the following table according to the location of the indoor unit.

#### Caution

Never select the direction of air discharge other than the following pattern. (You may have a condensation problem.)

In case of BYC71F	No. of setting position	02	02	02	02
	3-way air discharge				
	2-way air discharge				
In case of BYC125F	No. of setting position	02	02	01	01
	3-way air discharge				
	2-way air discharge				

### ● Installation



## (2) Installation of sealing member

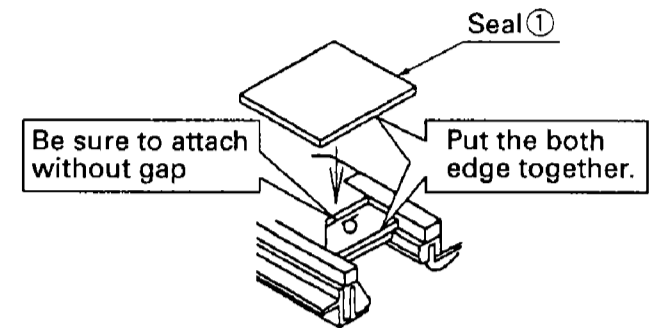
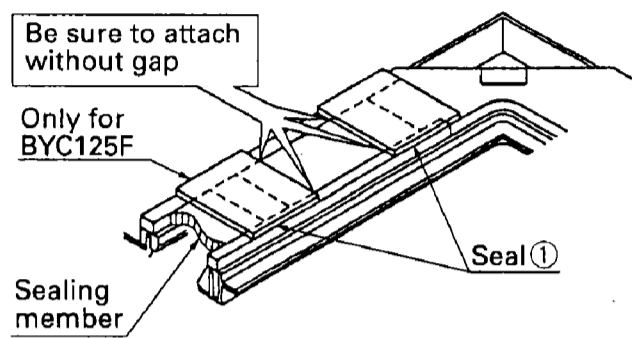
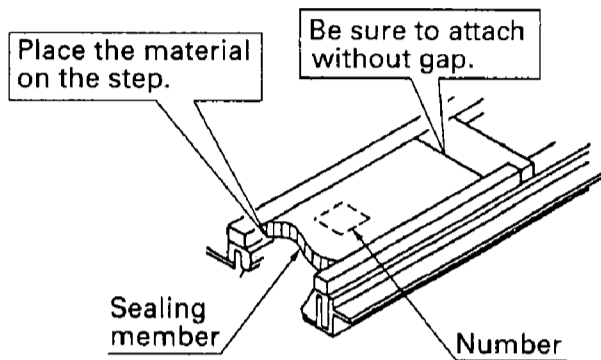
(When you have either 2-way or 3-way air discharge, the sealing member for high ceiling is not required.)

1) Be sure to install the sealing member of the same number with the number of setting position of the above table.

2) Install the seal ① on top of the joint part of the sealing member.

● Attach the seal on top of the sealing member (b)

● For BYC125F, attach the seal ① also on top of the center joint part of the sealing member.



## ② Setting of indoor unit

It is required to make a local setting on the remote controller according to the installation of indoor unit.

The direction of air discharge should also be set by the remote controller.

- The 3 different kind of setting such as "Mode number", "The setting switch number" and "The setting position number" should be made by the remote controller.
- Refer to the item of "Local setting" on the operation manual of the remote controller for the operating procedure.

(1) Set according to the table of "The selection of air discharge and the installation of the sealing member".

Check the setting position number corresponding to the direction of air discharge.

(2) Refer to the item of "Local setting" of the operation manual included in the remote controller and change the setting according to the position determined by (1) as shown in the table below.

	Mode number	Setting switch number	Setting position number
Setting of the direction of air discharge	13 (23)	1	01
			02
			03

### Caution

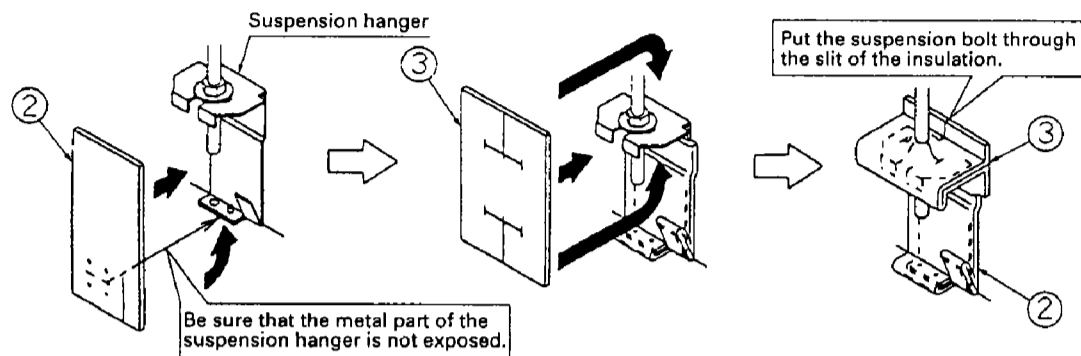
Refer to the table on the right hand side for the height of the ceiling for each direction of air outlet. (The setting of the ceiling height is also required.)

	4-way air outlet	3-way air outlet	2-way air outlet	Ceiling height setting position number
Ceiling height	~2.7	~3	~3.5	01
	2.7~3	3~3.3	3.5~3.8	02
	3~3.5	3.3~3.5	Not attainable	03

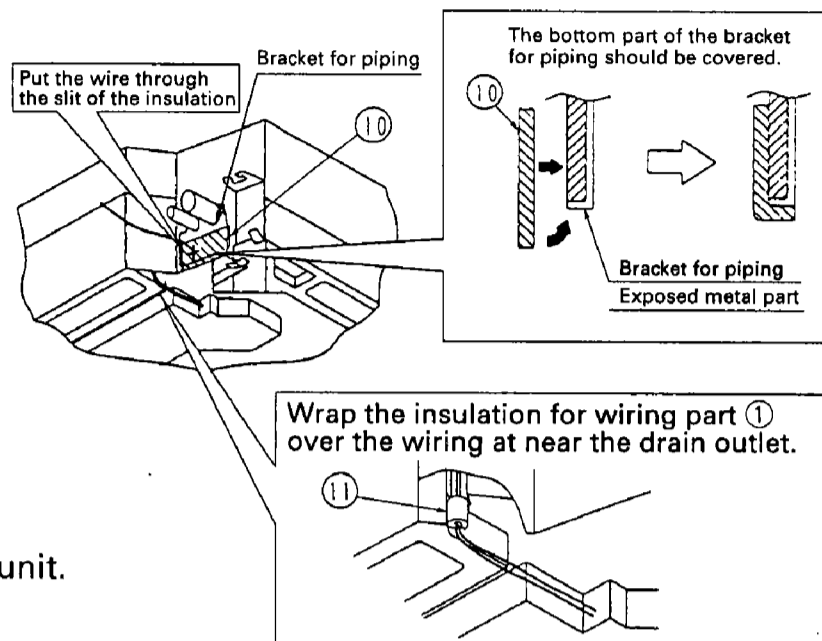
The height of the ceiling is only for the reference.

### ③ Installation of the insulation

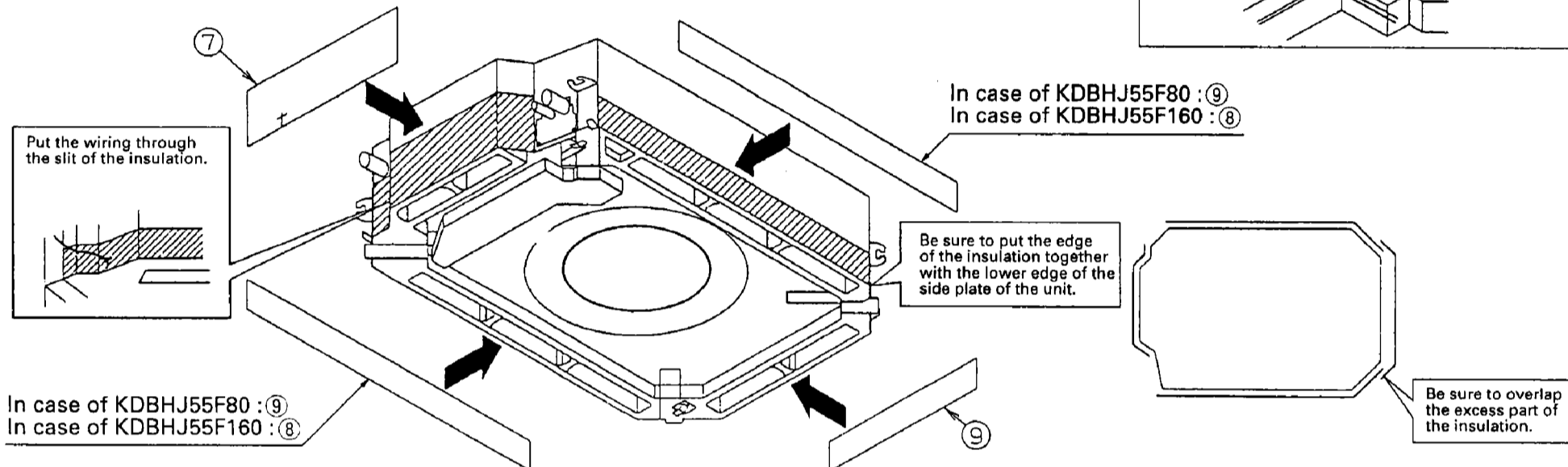
- (1) Insulation for suspension hanger (Be sure to attach after adjusting the height of the unit.)  
 Insulation ② and ③ for the suspension hanger should be attached to the four of suspension hanger in the order of ② → ③.  
 Be sure that the metal part of the suspension hanger is not exposed.



- (2) Insulation for the piping and wiring part  
 Attach the insulation for piping part ⑩ and insulation for wiring part ⑪ as follows.

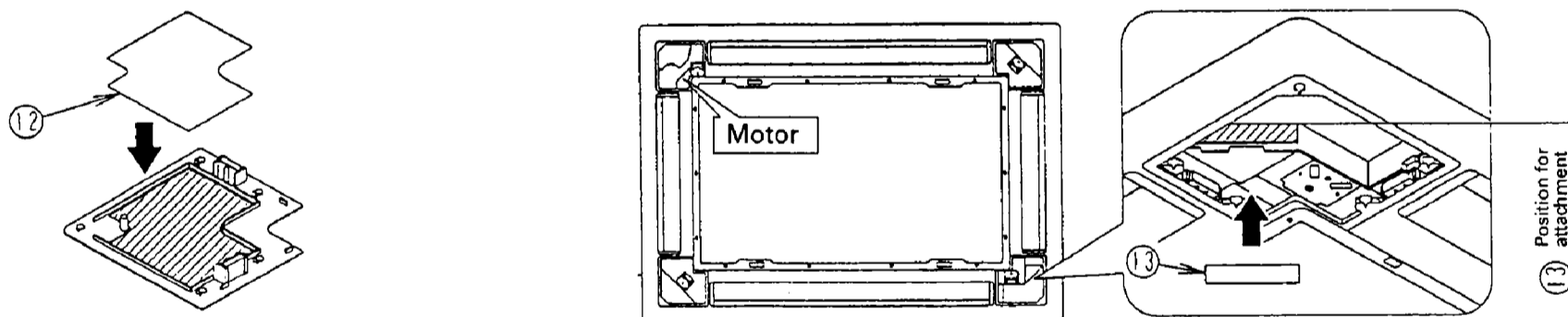


- (3) Insulation for side plate  
 Attach the insulation for the side plate ⑦ ~ ⑨ to the side of the indoor unit.



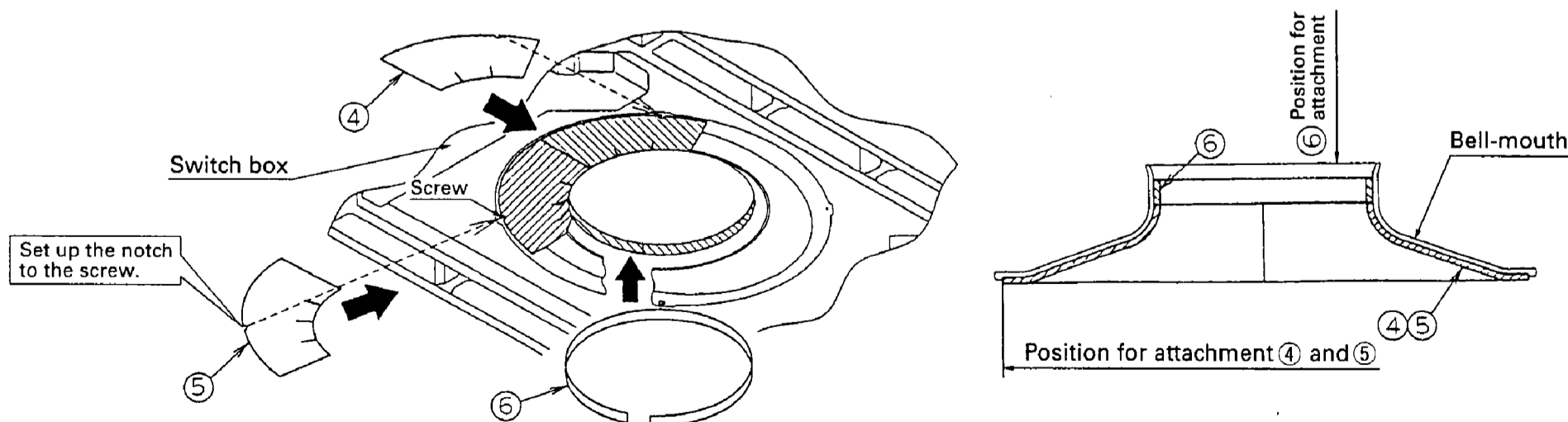
- (4) Insulation for decoration panel

- 1) Attach the moisture absorbing material ⑫ to the rear side of four corner decoration covers.  
 2) Attach the moisture absorbing material to the corner part located at the opposite side of the motor for the decoration panel.



- (5) In case of KDBHJ55F160, the following additional installation is required.

- Attach the moisture absorbing material ④ and ⑤ to the bell-mouth without wrinkles. Also attach the moisture absorbing material ⑥ around the top part of the bell-mouth putting together the both end of the moisture absorbing materials ④ and ⑤.





### 8.3 Panel spacer -KDBJ55F80W-160W

This optional kit shall be used when the space above the ceiling is not retained more than 260(300)mm. By using the panel spacer, the unit can be installed even in the limited space of 220(260)mm above the ceiling.

Note: The number in ( ) shows for the indoor unit 100F~125F.

Model name		KDBJ55F80W	KDBJ55F160W
Item		White	
Dimensions (mm)	Height	40	
	Width	950	1,340
	Depth	950	
Materials		Outer frame : Aluminum and plastic molding Thermal insulation materials : Foam polyethylene	
Component parts		Panel spacer, Thermal insulation materials, Screws	
Applicable model		For indoor unit 35F~71F	For indoor unit 100F~125F

#### ● Combination with the decoration panel

Be sure to check the combination of panel spacer and decoration panel.

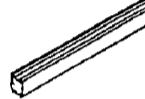
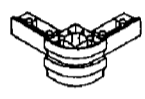
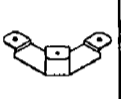

Panel spacer	KDBJ55F80W	KDBJ55F160W
Decoration panel	BYC71F(J)-W1	BYC125F(J)-W1

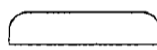
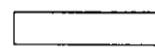

#### ● Caution

- When the panel spacer is installed, it is not possible to have 2-way air outlet.
- Refer to the installation manual for both indoor unit and the panel spacer for its installation.

#### ● Contents of kit

Prior to installation check whether you have the complete kit of parts as shown below including the installation manual.

Name	Panel spacer frame	Plastic corner joint	Fixing metal	Screws
Quantity	4 set	4 set	4 set	28 set
Shape /number	① 	② 	③ 	④ 

Name	Sealing pad		Caution sticker
Quantity	2 set	2 set	1 set
Shape /number	⑤ 	⑥ 	⑦ 

### ① Preparation of decoration panel

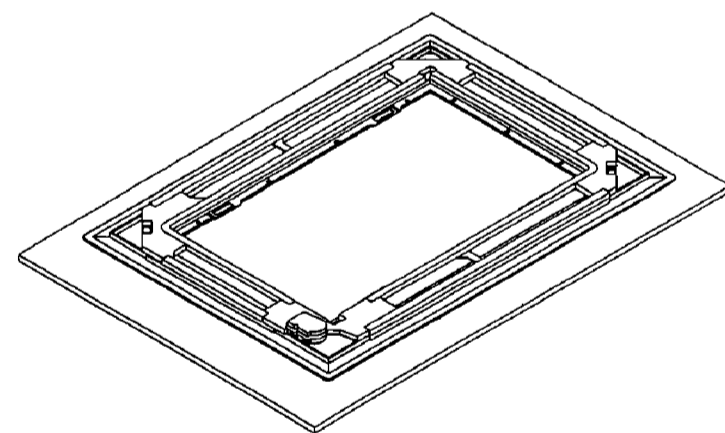
#### ● Handle the decoration panel with care.

Never place the panel face down, or lean the panel against wall or place on the projective object. (It causes the dent or damage of the surface of the panel or damage of swing motor.)

(1) Remove the suction grille from the decoration panel.

(Refer to the installation manual of the decoration panel how to remove.)

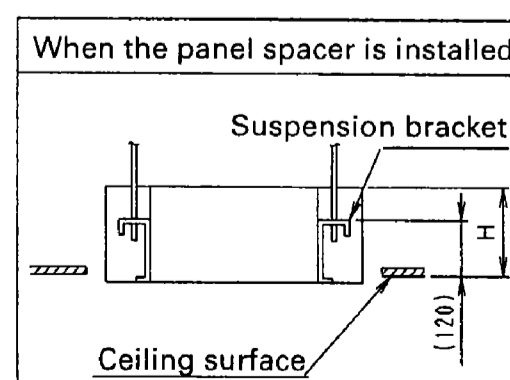
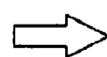
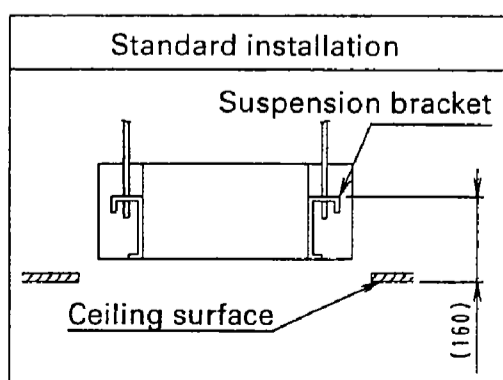
(2) Place the panel face down on the corrugated cardboard or the vinyl sheet to protect the surface of the panel.



### ② Installation of the indoor unit

Adjust the height of the indoor unit.

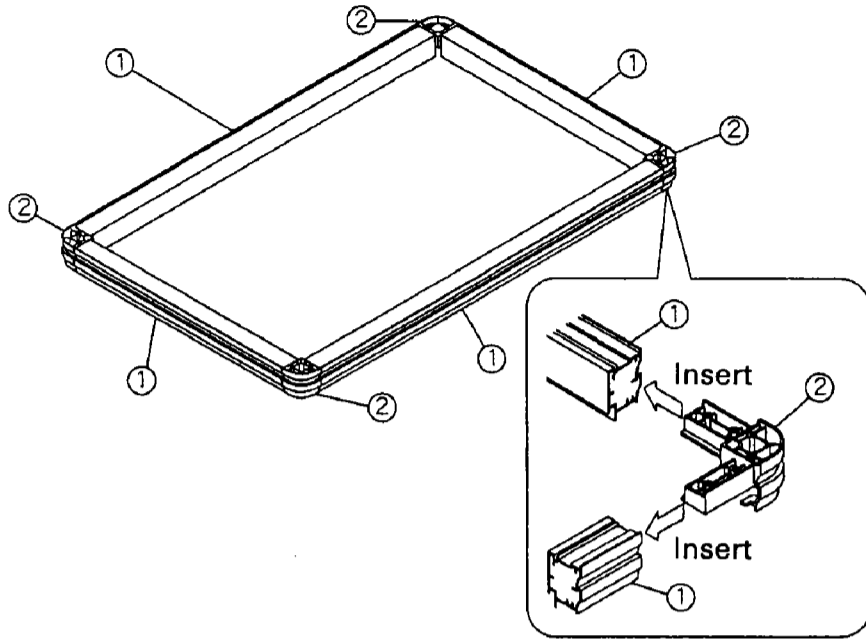
Be sure the piping will not contact with the ceiling joint etc. after adjusting the height.



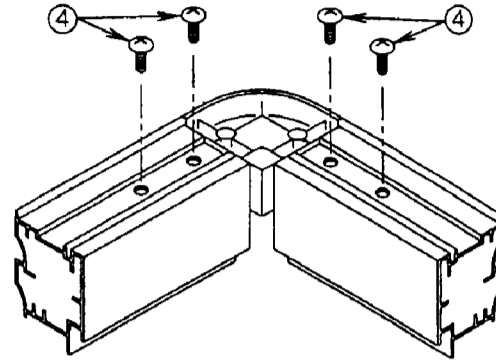
Indoor unit	H
71 type	220
125 type	260

### ③ Assembly of panel spacer

(1) Assemble the panel spacer frame ① and the plastic corner joint ② temporarily.

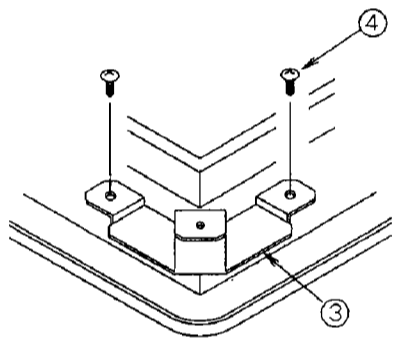


(2) Fix with the screws ④ from the top. (4 screws in each corner)

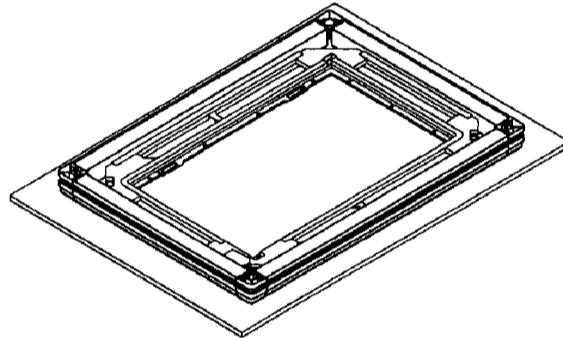


### ④ Fixing to the decoration panel

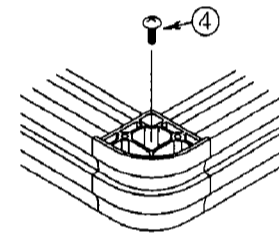
(1) Set the fixing metal ③ on each corner with screws ④.



(2) Place the panel spacer assembled in item ③ of the above on the outer frame of the decoration panel.

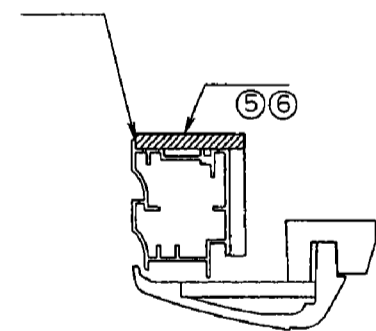
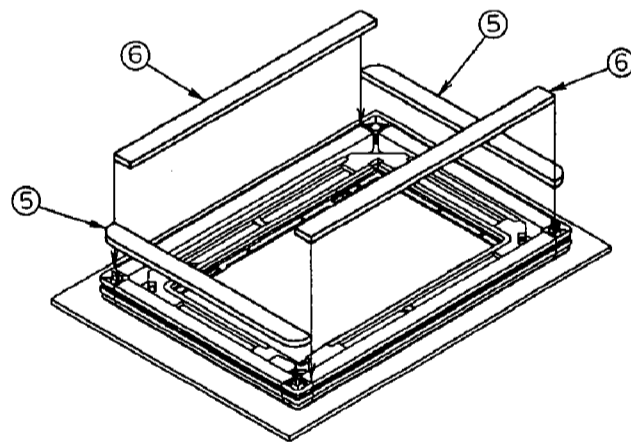


(3) Fix the panel spacer to the fixing metal ③ with screws ④.



### ⑤ Attach the sealing pad

Attach the sealing pad ⑤ ⑥ on the upper face of the panel spacer in the order of ⑤ and ⑥.

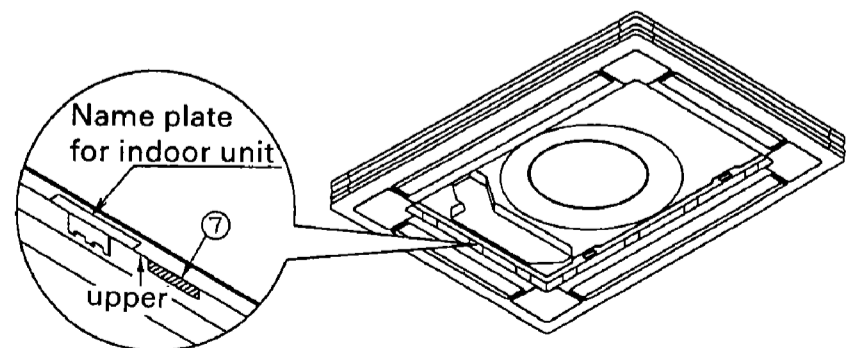


### ⑥ Installation of decoration panel

(1) Install the decoration panel to the indoor unit according to the installation manual of panel spacer.

The panel spacer is not firmly fixed to the decoration panel, so that never hold the panel spacer directly or lean the decoration panel extremely.

(2) After installation of decoration panel, attach the caution sticker ⑦ next to the name plate of the indoor unit as shown on the right.



## 8.4 Air discharge grille - KAWJ55F80 · 160 KAWVJ55F80 · 160

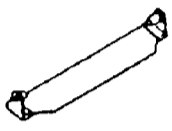
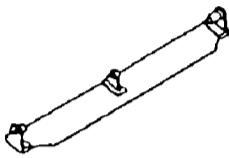
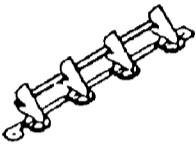
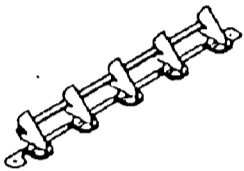


### ● Specifications

Model name	KAWJ55F80	KAWJ55F160	KAWVJ55F80	KAWVJ55F160
Item				
Vertical flap	Non (Only horizontal flap)		With (Vertical flap+ Horizontal flap)	
Applicable model	For indoor unit 35F~71F	For indoor unit 100F~125F	For indoor unit 35F~71F	For indoor unit 100F~125F

- Use this optional accessories when horizontal flap or both horizontal and vertical flap becomes dirty or is broken.

### ● Contents of kit

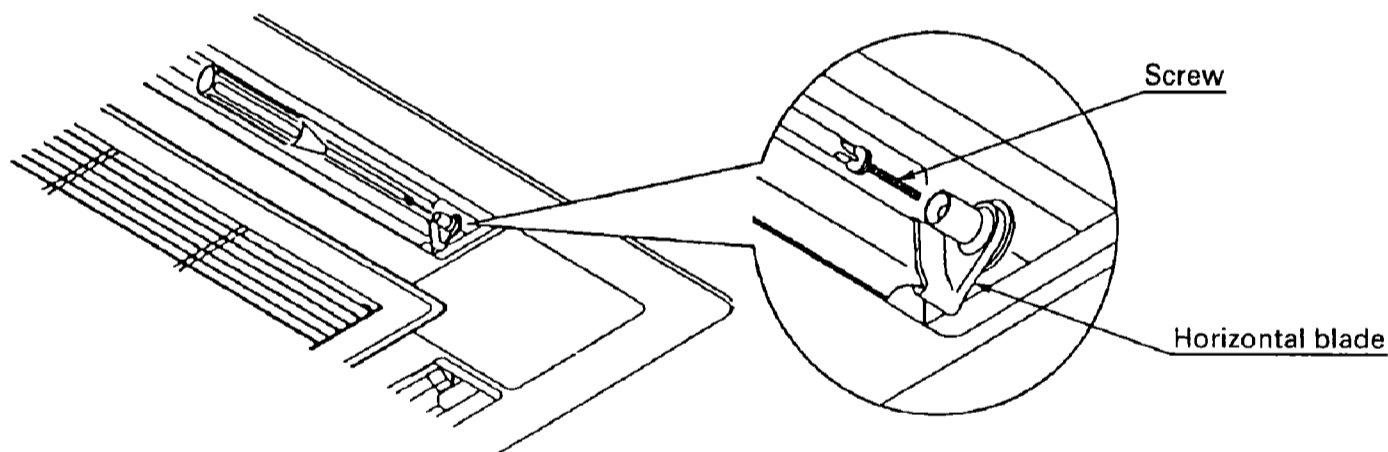
Prior to installation check to make sure you have the complete kit of parts.

Name	Horizontal blade (small)	Horizontal blade (large)	Vertical blade (small)	Vertical blade (large)	Screws ①	Screws ②
Shape						
					M4x20	M4x8
Quantity						
KAWJ55F80	4	—	—	—	8	—
KAWJ55F160	2	2	—	—	8	—
KAWVJ55F80	4(with hole)	—	8	—	8	16
KAWVJ55F160	2(with hole)	2(with hole)	4	4	8	16

### ① Removing the horizontal blade

Remove the horizontal blade to be replaced as follows.

- (1) Set the air discharge direction to the lowest position by remote controller.  
(Refer to the operation manual for the operation of remote controller.)
- (2) Loosen the screws of both end of the horizontal blade by the screw driver.



- (3) Remove the horizontal blade.

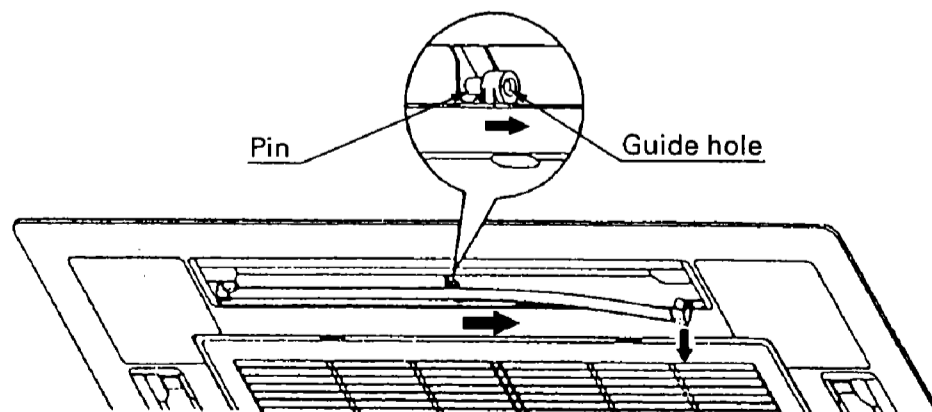
The horizontal blade can be removed by turning the blade to the horizontal direction.



If not, bend the horizontal blade slightly.



For BYC125F, the longer horizontal blade can be removed by bending the right side of the blade slightly and slide the blade to pull the pin out of the guide hole located at the center.

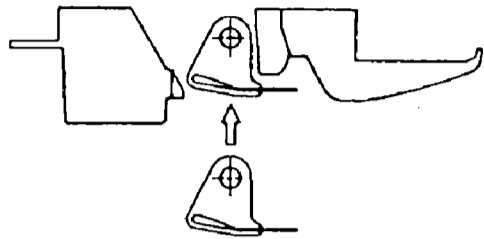


## ② Installation of horizontal blade

Set the horizontal blade in the reverse manner when you removed.

(1) Place the horizontal blade temporarily

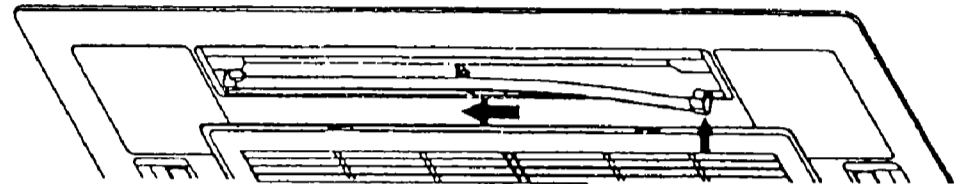
① Hold the horizontal blade at horizontal level and push it up.



② It can be set temporarily by turning the blade to the direction of downward.

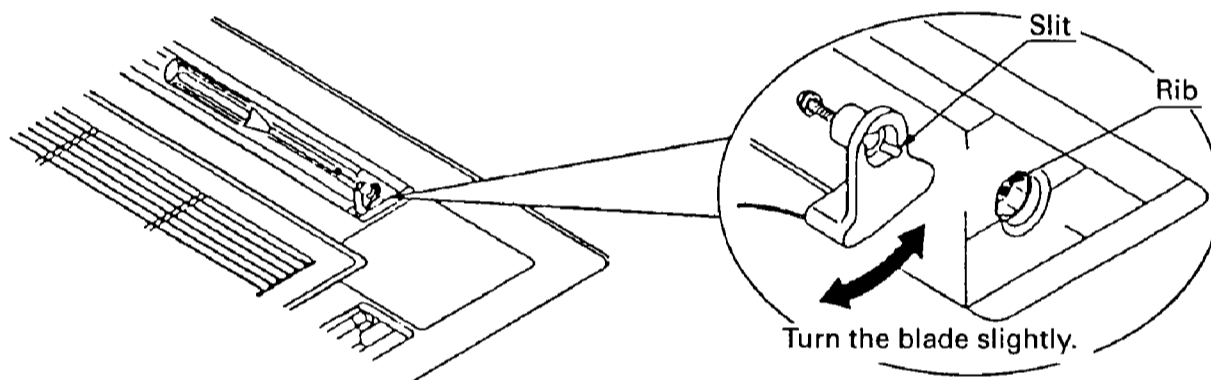


For BYC125F, the longer horizontal blade can be set by bending the right side of the blade slightly and slide the blade to put the pin into the guide hole located at the center.



(2) Set the horizontal blade with the screw ①.

When you set the blade with screw, turn the blade slightly to set the rib at each end of the air discharge outlet into the slit of the horizontal blade.



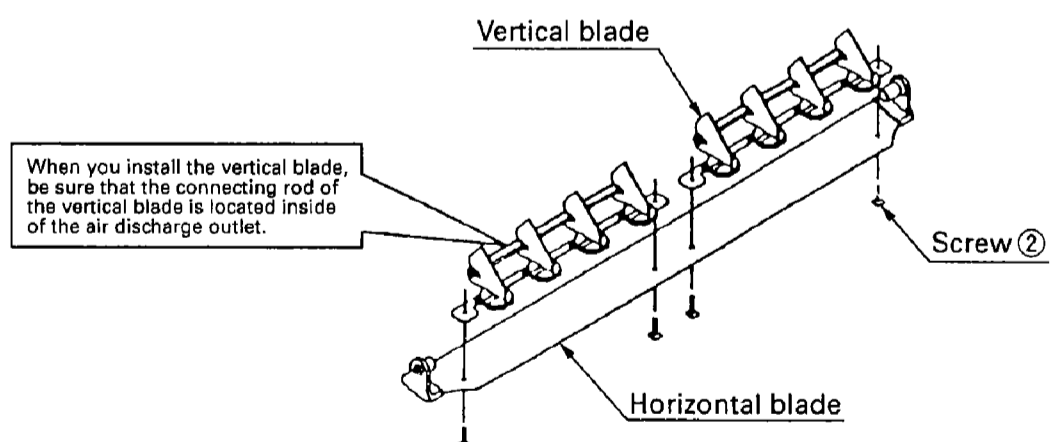
## ③ Installation of vertical blade

< Vertical blade is only supplied with KAWVJ55F80 and KAWVJ55F160. >

### Caution

Set the vertical blade with screw after installing the horizontal blade to the decoration panel.

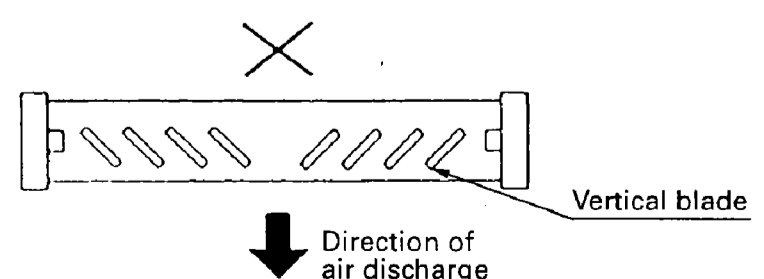
Set the horizontal blade to the lowest discharge position and place the vertical blade on top of the horizontal blade, and fix the both end of the vertical blade with screw from the bottom of the horizontal blade.  
For BYC125F, the vertical blade (large) should be set to the horizontal blade (large).



## ④ After completion of installation

< Be sure to explain the customer the following point. >

Never set the vertical blade as shown on the right.  
The air discharge outlet of the decoration panel may have a condensation.



## 8.5 Lifter style air suction grille

(Lift for ascent and descent + Chamber for lift-arm + Exclusive suction grille)

KDVJ55F80 · 160

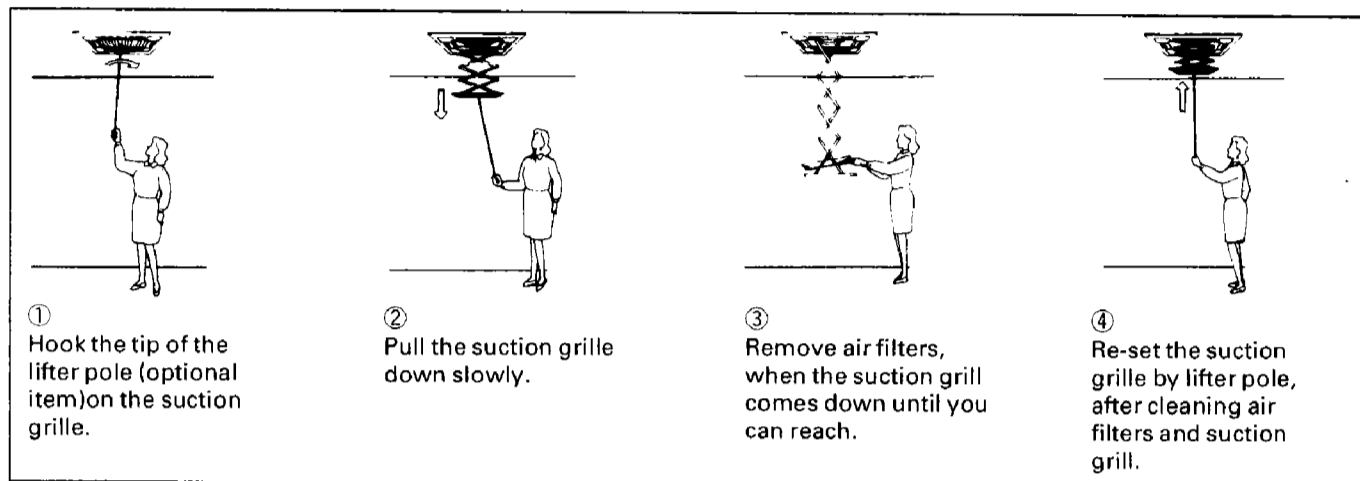
### "Operation and Installation"

#### ● Purpose

Lifter style suction grille (Lifting grille) is available as optional accessory, which enables to remove air filter without using a ladder.

It facilitates the maintenance of suction grille and air filters.

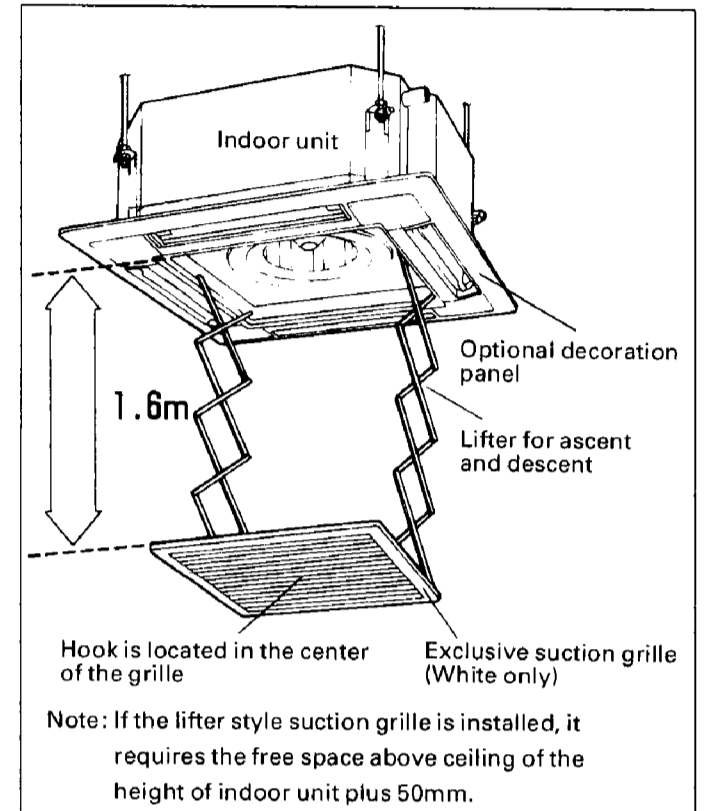
#### ● How to use lifter style suction grille



#### Caution

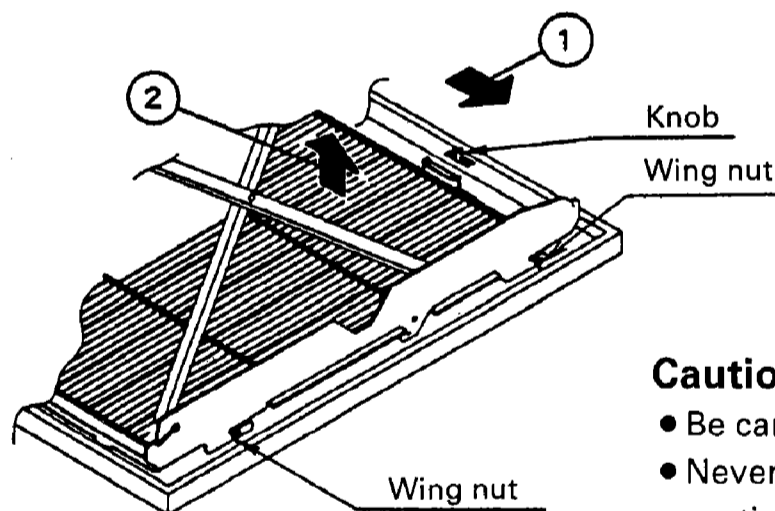
- Never place the goods on the suction grille or never put the pressure to the suction grill when the suction grille is going down.
- Pull the suction grille directly below. Never pull the suction grille oblique direction.
- Never remove the lifting pole when you push up the suction grille.  
(If you remove the lifting pole when you push up the suction grille.)

#### ● Maximum reach of lifter style suction grille

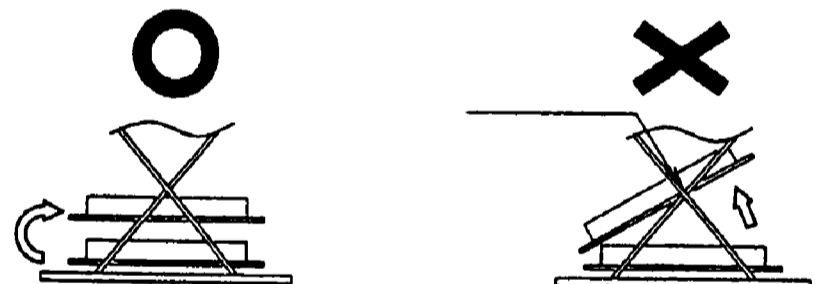


#### ● How to remove the air filter from the suction grille

- ① Slide the knob on the rear side of the suction grille to outside.
- ② Pull the knob of the air filter and remove.



- Hold the air filter horizontal when you remove or re-set.



#### Caution

- Be careful that the dust may fall down when you pull the suction grille down.
- Never force to push the grille when you have a difficulties to re-set, and pull the suction grille down once again and check whether the wire is not stuck with the arm.

#### ● How to clean the suction grille

- ① Remove the air filter.
- ② Wipe off the suction grille with the soft cloth containing water or detergent. Never use the hot water of more than 50°C. The suction grille may be deformed by the heat.

#### Caution

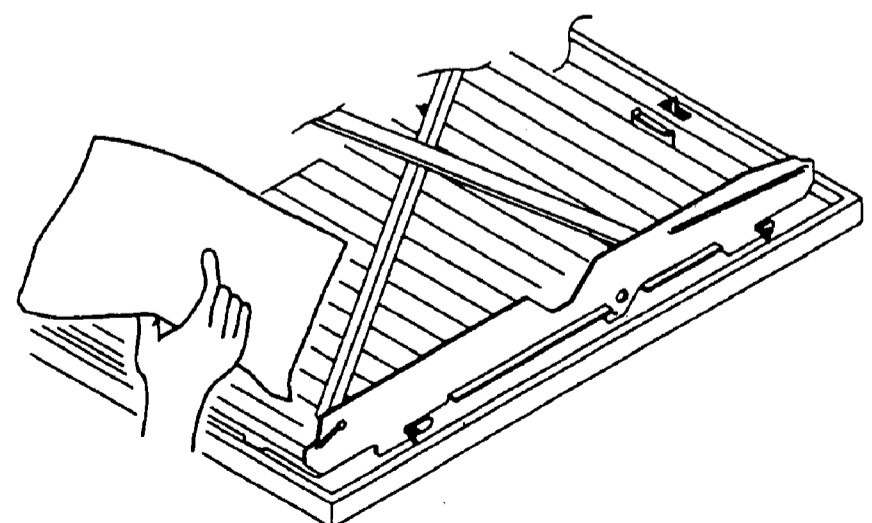
Do not put the force on the suction grille, which may release the white-lock and the grille may start rising.

#### Warning

Never remove the suction grille from the arm when you clean the suction grille.

Ask your dealer if you want to remove the suction grille.

If the suction grille is removed and if the wire-lock is released, the suction grille may bound, which may cause the damage or injury.



## ● Trouble shooting

Check the following before you make a service call.

Symptom	Cause	Remedy
Suction grille does not go up.	Check whether the wire-lock is not released.	Pull the suction grille down once again to release the wire-lock.
The suction grille cannot be re-set.	Check whether the foreign object is on the grille.	Remove the foreign object.
	Check whether the foreign object is stuck at the corner. (The magnet is installed at every four corners.)	Remove the foreign object.
The abnormal sound is heard.	Check whether the wing nut is loose.	Tighten the wing nut.

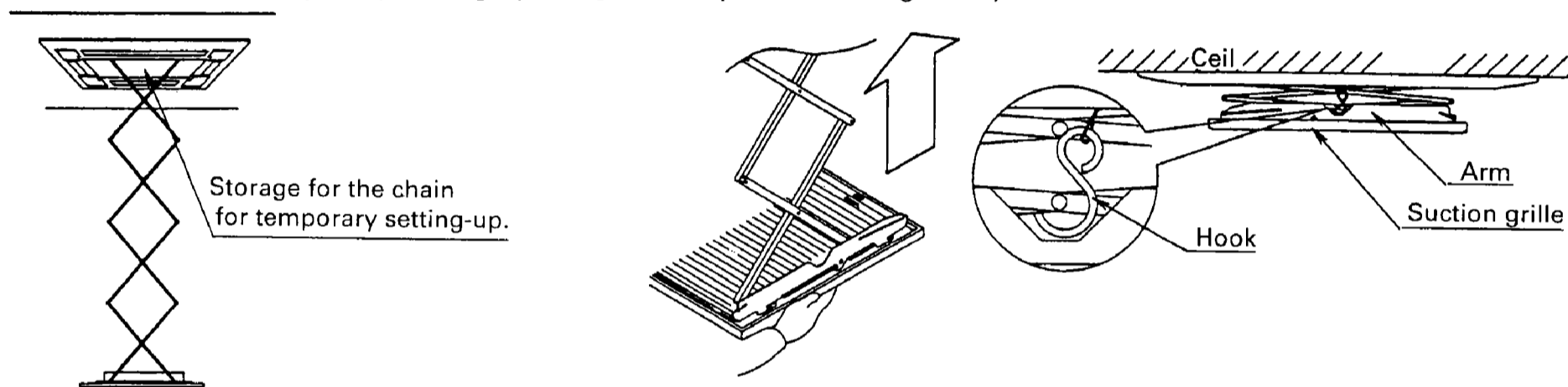
If you still cannot resolve the trouble, never try to repair and call the dealer from where you purchased.

If you have the following case, call the dealer for repair.

Symptom	Call the dealer after taking the following remedy.
The suction grille does not move at all.(Arm deformed)	Disconnect the power supply.
The suction grille does not rise. (Wire broken or disconnected.)	Disconnect the power. If the suction grille can be lifted by hand (The arm is not damaged.), you can set-up the suction grille temporarily as follows.

## ● Temporary set-up of the suction grille(Be careful to do it, it will be the work on the elevation.)

- ① Pull out the chain for temporary setting-up.    ② Push up the suction grille by hand.    ③ Hook the chain to the arm.



## Caution

- Be sure to check the model name of the indoor unit on the table before installing.
- Refer also to the installation manual of the indoor unit and the decoration panel.
- Be sure to use the air filters and the suction grille in the kit.
- When the optional kit of the installation box for the adapter PCB is installed, be sure to install that optional kit before this kit is installed.
- We recommend to use the lifter pole (option kit) together with this kit.

Optional kit Lifter pole(KDVJ55F80Z)

## ● Combination with the indoor unit and the decoration panel

Model name	Applicable indoor unit	Decoration panel
KDVJ55F80	FH(Y)C35~71F FXYP32K~63K	BYC71F(J)-W1
KDVJ55F160	FH(Y)C100~125F FXYP80K~125K	BYC125F(J)-W1

Note: For model BYC71F and BYC125F(Standard type), the air filter and the suction grille of the standard accessories shall not be used.

## Contents of kit

Prior to installation check whether you have the complete kit of parts as shown below including the installation manual.

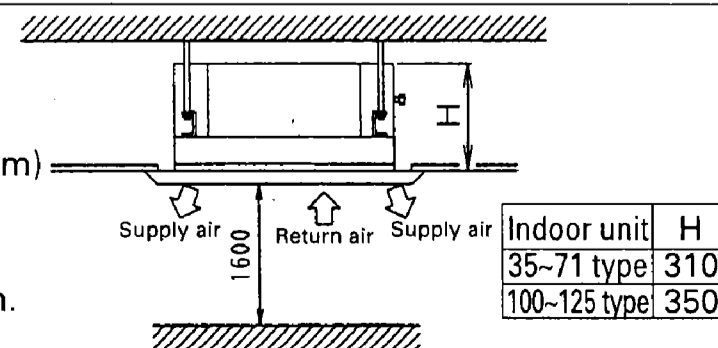
Name	Chamber for the lifter style suction grille	Suction grille with air filter	Screws	Thermal insulation for suspension bracket	Setting metal	Screws	Installation manual
Shape	①	②	③	④	⑤	⑥	⑦
Quantity	1 set	1 set	4 pieces	4 pieces	4 pieces	4 pieces	1 pc

## ① Selection of the location for installation

- Be sure to keep at least 1.6m of free space directly below the unit, because the suction grille can only be removed when extended down to 1.6m.
- If the ceiling is high, you may require a ladder to operate this kit.
  - This kit can be operated without ladder at the standard ceiling height. (about 2.7m)

## Caution

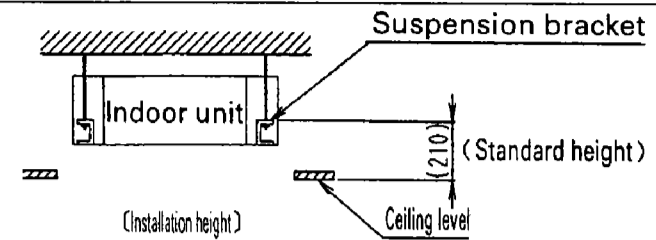
Never install the kit in such a place where the mineral oil hangs over, or in the kitchen where it is filled with the oil, the splash of the acid or alkaline, or the steam. (There is a possibility to damage the plastic parts.)



## ② Installation of the indoor unit

Install the indoor unit.

- Refer to the drawing on the right for the installation height.
- Be sure to complete the refrigerant piping and the drain piping before the installation of the lifter style suction grille.
- Refer to the installation manual of the indoor unit for other details.



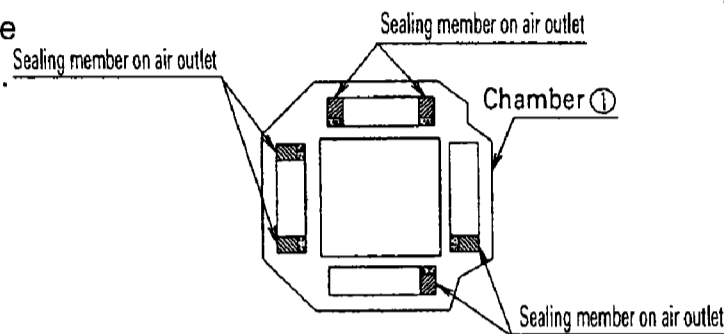
## ③ Installation of the chamber for lifter style suction grille

- (1) Be sure to remove the sealing members (6 locations) on the air outlet if the lifter style suction grille is installed on the following indoor unit.

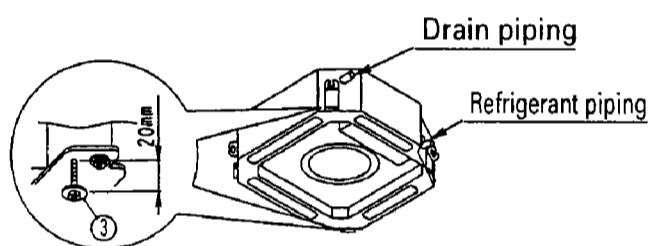
Otherwise it may cause the condensation on the grille.

The indoor unit, which is required to be removed the sealing members on the air outlet

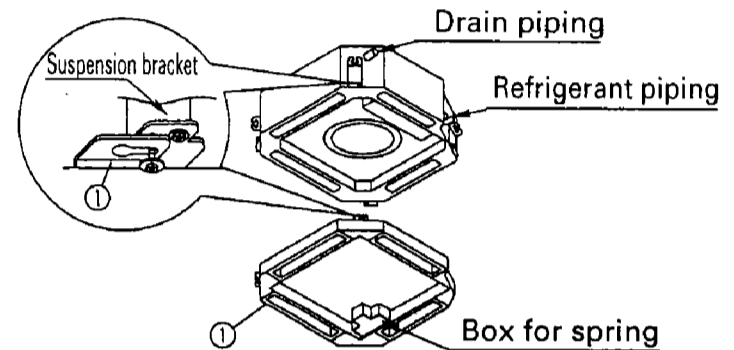
Sky-air	FH(Y)C35~71F
VRV	FXYF32K~63K



- (2) Set the screws (3) to the indoor unit temporarily.  
(2 locations: opposite side of the drain connection)



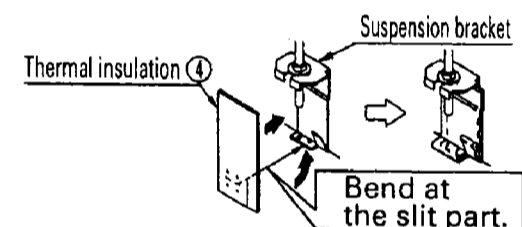
- (3) Hook the chamber (1) on the screws (3) set temporarily.  
(Refer to the position of the drain piping and the refrigerant piping for the setting direction of the chamber.)



- (4) Set the remaining 2 screws (3) and fasten all of 4 screws tightly.

Be sure to fasten all the screws so as no gap between the indoor unit and the chamber.

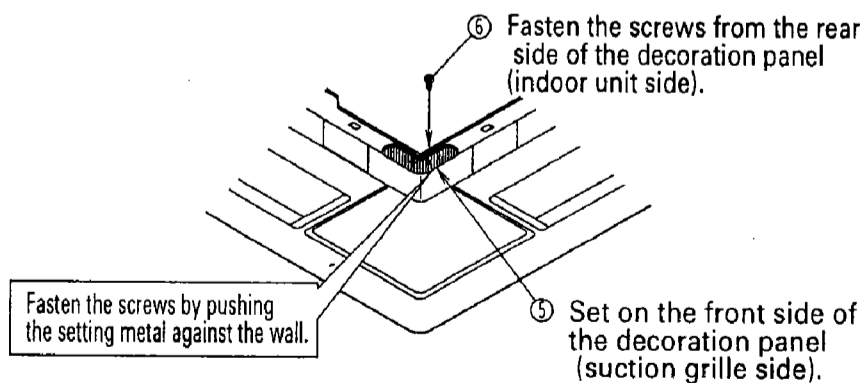
- (5) Attach the thermal insulation (4) on the metal part of the suspension bracket. (4 locations) Be sure to cover the metal part completely.



## ④ Installation of the decoration panel

### Using the BYC71, 125F(J) standard type

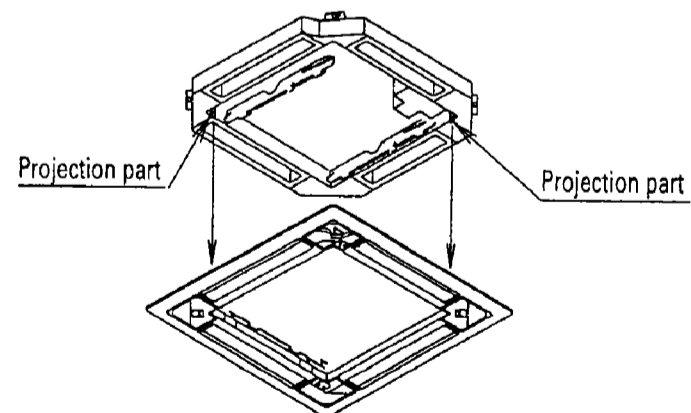
- (1) Remove the air filters and the suction grille of standard accessories.
- The suction grille and the air filters removed shall not be used.
- (2) Fix the setting metal (5) on each corner with the screws (6).
- The suction grille is held closed by the magnet filled in the suction grille.



- (3) Refer to the installation manual of the decoration panel for its installation.

### Caution

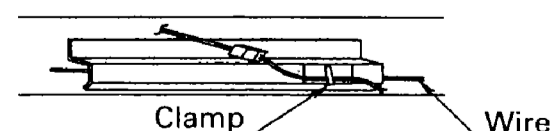
When you hook the decoration panel temporarily and fasten the screws tightly, be sure to adjust the position of the decoration panel to place the projection part of the chamber inside of the opening of the decoration panel.



### • Electrical wiring

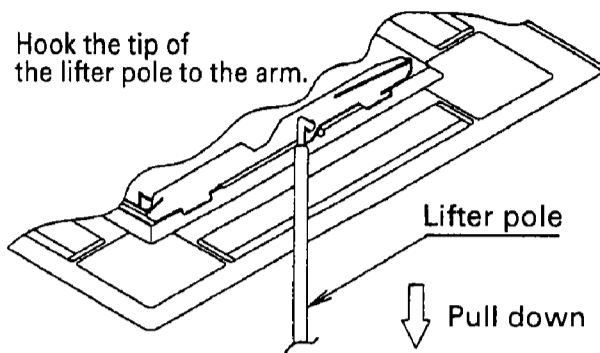
Clamp the wire of the swing motor (side of the box for spring) to the chamber.

It may cause the electrical shock or fire, if the electrical wiring contacts to the wire of the wire of the suction grille.



## ⑤ Installation of the suction grille

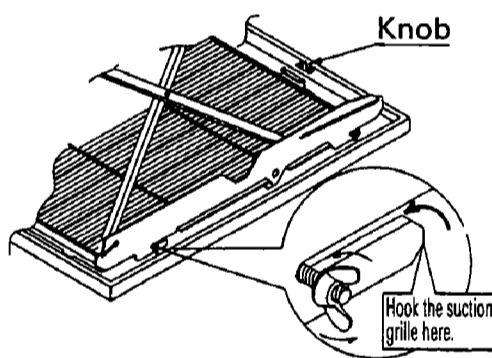
- (1) Pull the arms down to the desired position. (Max.1.6m from the panel)



### Caution

- Be sure to hook the tip of the lifter pole to the arm securely. Otherwise, the arm may jump up when the lifter pole slips out from the arm and it may cause the damage or injury.

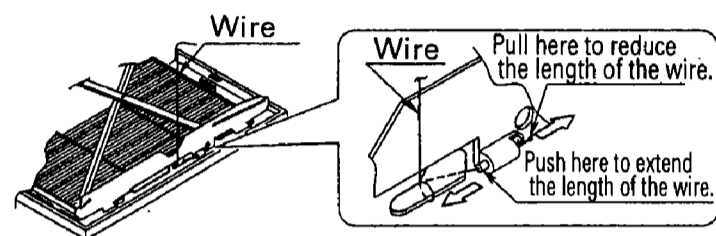
- (2) Loosen the wing nut on the suction grille and hook the suction grille to the slit of the arm. (Refer to the location of the knob for the direction of the suction grille.) Slide the suction grille to the end of the slit and fix with the wing nut securely. (The suction grille cannot be set up to the decoration panel unless the suction grille is slid into the end of the slit.)



- (3) After releasing the wire-lock by pushing the suction grille down once, hook the tip of the lifter pole to the hook of the suction grille and set up the suction grille into the decoration panel.
- (4) When you cannot set up the suction grille, pull the suction grille down once more and adjust the length of the wire as follows.

In case the refrigerant piping side of the suction grille cannot be set up: Reduce the length of the wire.

In case the opposite side of the refrigerant piping side cannot be set up: Extend the length of the wire



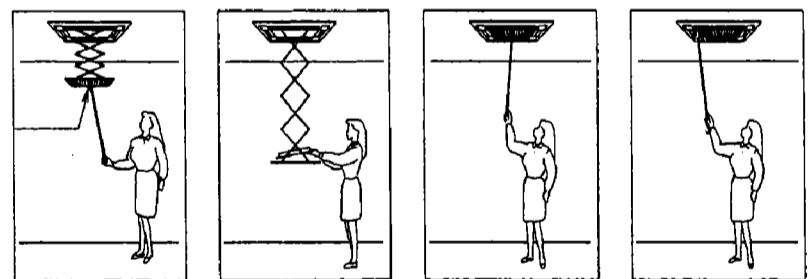
### Caution

- Never pull the arm down during the installation of the suction grille. If the arm is pushed down, the wire-lock is released and the arm may jump up, which may cause the damage or injury.

### Commissioning

Be sure to check the operation after the installation of the suction grille.

- 1 Hook the tip of the lifter pole to the hook of the suction grille and pull the suction grille down to the desired position.
  - 2 Push the suction grille up and set up the suction grille into the decoration panel as described in the item (3) of the above.
- Be sure to check the smooth operation of the suction grille by repeating the step "1" and "2" of the above a few times.
- 3 If the suction grille cannot be set into the decoration panel properly, push the suction grille by the grip part of the lifting pole.



- 1 Pulling the suction grille down
- 2 Setting up of the suction grille
- 3 Pushing up by the grip of the lifter pole

## ⑥ After the completion of the installation

(You are requested to explain the following points to your customers.)

Be sure to explain the following to the customer by referring the operation manuals for both the indoor unit and the lifter style suction grille.

- How to operate the lifter style suction grille up and down.
- How to remove or set up the air filter and also how to clean the air filter.
- Be sure to explain carefully how to remove or attach the suction grille.

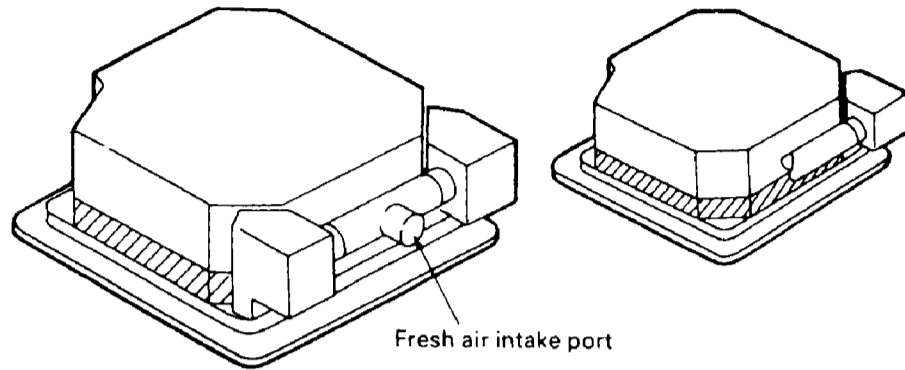


## 8.6 Fresh air intake kit – KDDJ55F80-160

The fresh air is taken into the unit by the indoor unit fan or duct fan which is field supplied.

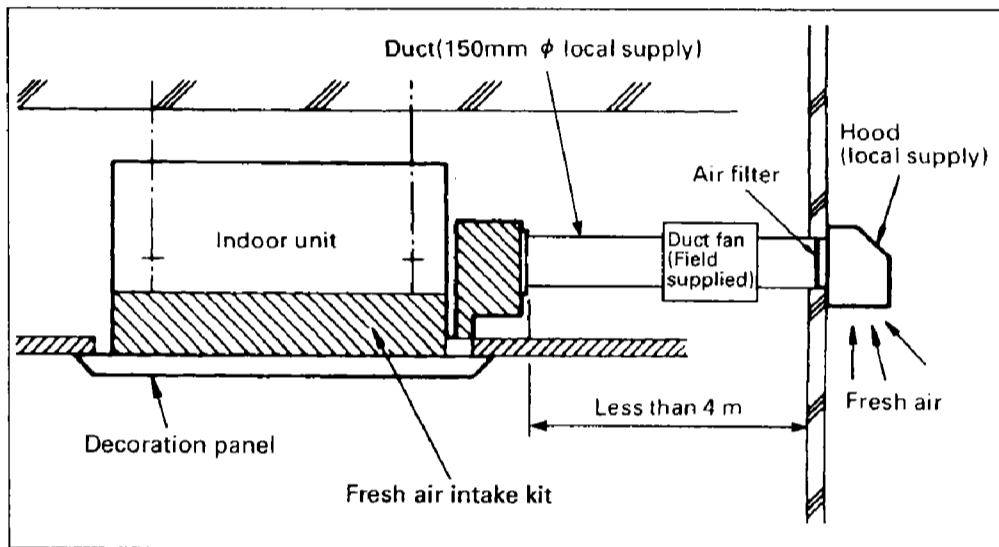
Inlet of fresh air intake

(KDDJ55F80-160 (without duct fan))



The location of fresh air intake port will be changeable by installing the duct fan.

### ● Example of installation



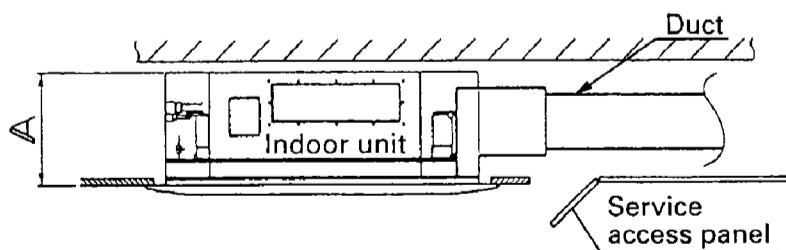
### ● Contents of Kit

Prior to installation check to make sure you have the complete kit of parts.

Name	① Suction chamber	② Connecting chamber (right)	③ Connecting chamber (left)	④ Insulation for outer plate	⑤ Seal material	Screws		⑧ Insulation for suspension hanger	⑨ Installation manual
Quantity	1 piece	1 piece	1 piece	2 pieces	1 piece	4 pieces	4 pieces	4 pieces	1 piece
Shape						⑥  M5 x 30	⑦  M4 x 12		

### ① Selection of the location for a indoor unit and a service access panel

(1) Refer to the following figure to select the location for the indoor unit and the service access panel.



Indoor unit	A	B
35F ~ 71F type	310	725
100F ~ 125F type	350	920

(3) If the location will not allow to install the connecting chamber on both side, install only on the one side. In this case, be sure to cover the other opening by the sealing material⑤. (Refer to item ④ of this manual for its installation.)

### Caution

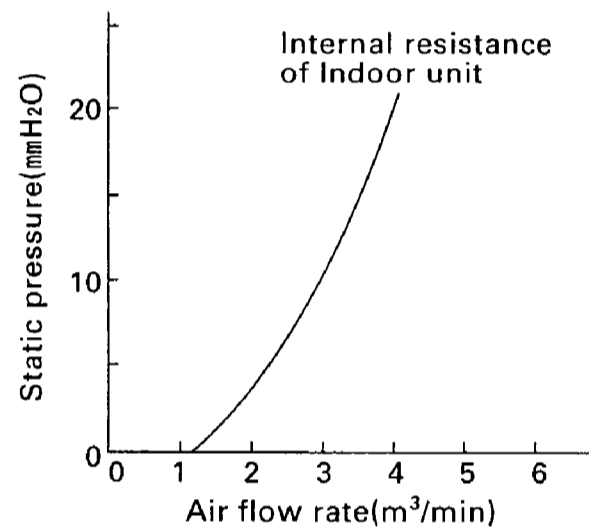
- Install the right side connecting chamber only as shown on the right, if the receiver unit of wireless remote controller is installed.
- Note that the operating noise is higher when the fresh air is taken through only one side.

### ● Specifications

Item	Kit name	KDDJ55F80	KDDJ55F160
Method of fresh air intake		Fresh air intake by the indoor unit fan.	
Size of connecting duct		φ150	
Applicable model		For indoor unit 35F~71F	For indoor unit 100F~125F

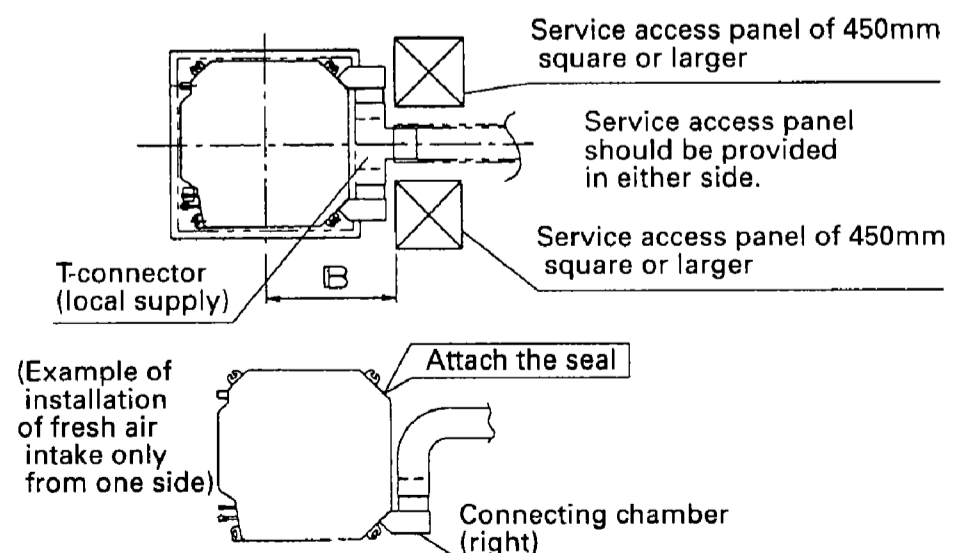
### ● Cautions

- This kit can only be installed on the ceiling mounted cassette type(Multi-flow type) air conditioner.
- Check the model name of indoor unit in the table before installation.
- When you install the duct fan (field supplied), the resistance (static pressure) of indoor unit is as follows.
- Internal resistance of indoor unit



Select the duct fan from this graph.

(2) Be sure to install the service access panel.



## ② Installation of suction chamber

When you install the suction chamber on the following model, be sure to remove seals (6 pieces) from the air outlet, in order to prevent the condensation. (See the figure on the right.)

Indoor unit model, which is required to remove the seals from the air outlet	
Sky-Air series	FH(Y)C35~71F
VRV system	FXYF32K~63K

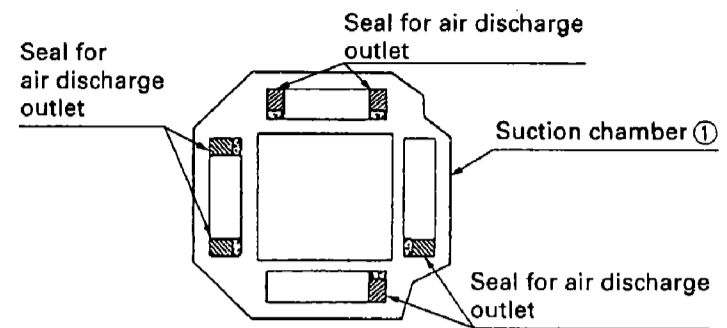
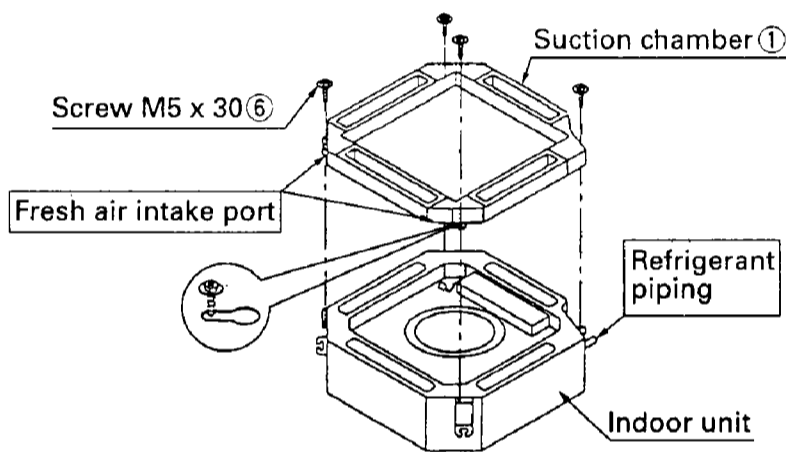
[ Be sure to remove the seals from the above unit in order to prevent the condensation.]

(1) Remove the decoration panel. (This is not required if it is a new installation.)

- Remove the decoration panel in the reverse step when you install the panel. (For details, refer to the installation manual included in the decoration panel.)

(2) Set the suction chamber to the unit with 4 screws of M5 x 30 ⑥.

(If the indoor unit is already installed, set the suction chamber temporarily by using two temporary hooks.)



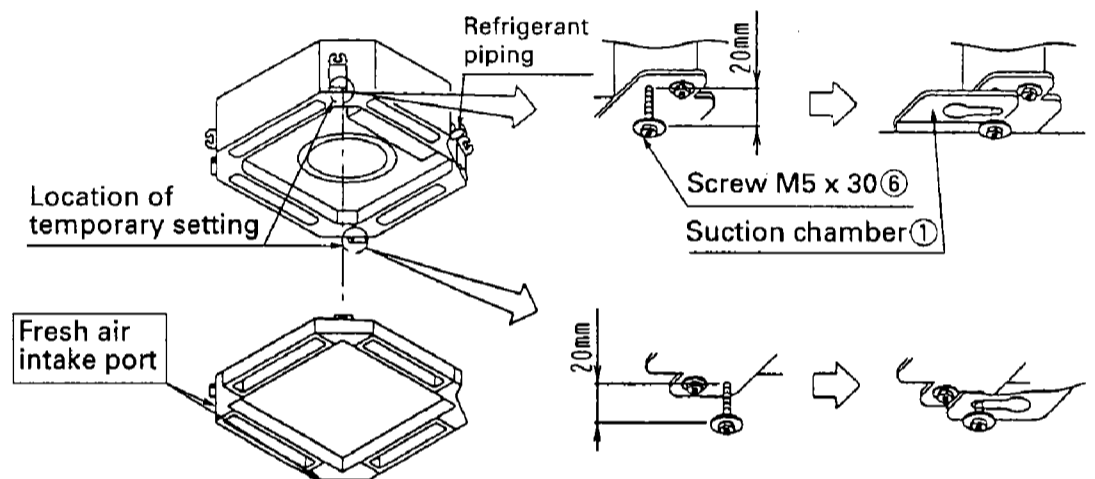
### ● Procedure for temporary setting

(2-1) Set two screws M5 x 30 ⑥ to the unit temporarily. (2 places)

(2-2) Hook the suction chamber temporarily.

(The direction of installation should be determined according to the location of refrigerant piping and fresh air intake.)

(2-3) Set the remaining two screws M5 x 30 ⑥ to the unit and tighten all of four screws.



### Caution

- Tighten the screws (of four corners) until the suction chamber is joined to the indoor unit closely.
- Be sure the lead wire from indoor unit to decoration panel is not caught in between the indoor unit and the suction chamber.

## ③ Installation of indoor unit and suction chamber

- Install the indoor unit and the suction chamber.

The installation work should be carried out according to the installation manual included in the indoor unit. (Refer to the right hand figure for the appropriate height of the indoor unit.)

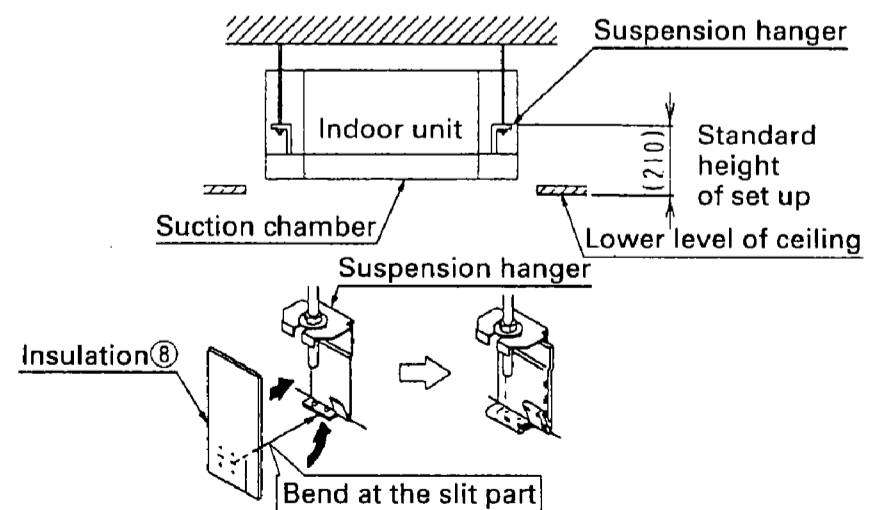
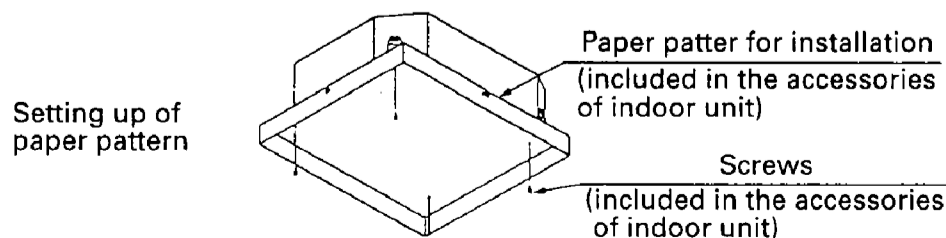
- Attach the insulation ⑧ to the suspension hanger. (4 places)

When you attach, be sure that the all the metal part is completely covered.

- Complete the refrigerant piping and drain piping work of the unit.

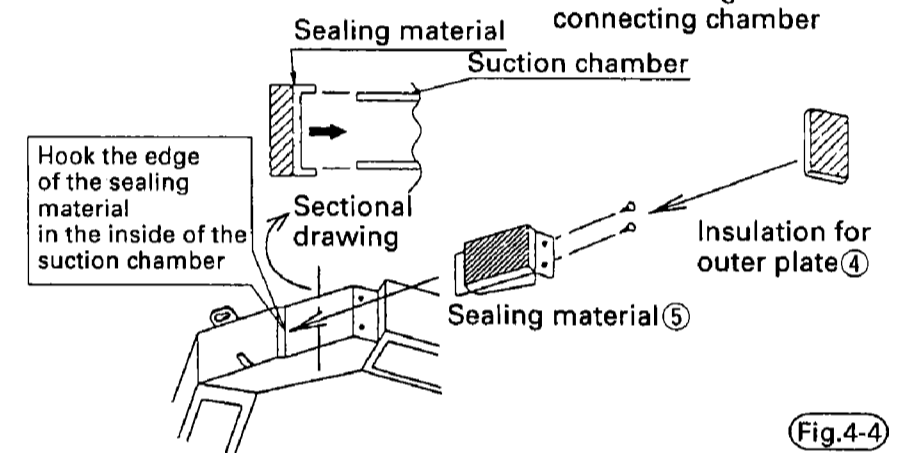
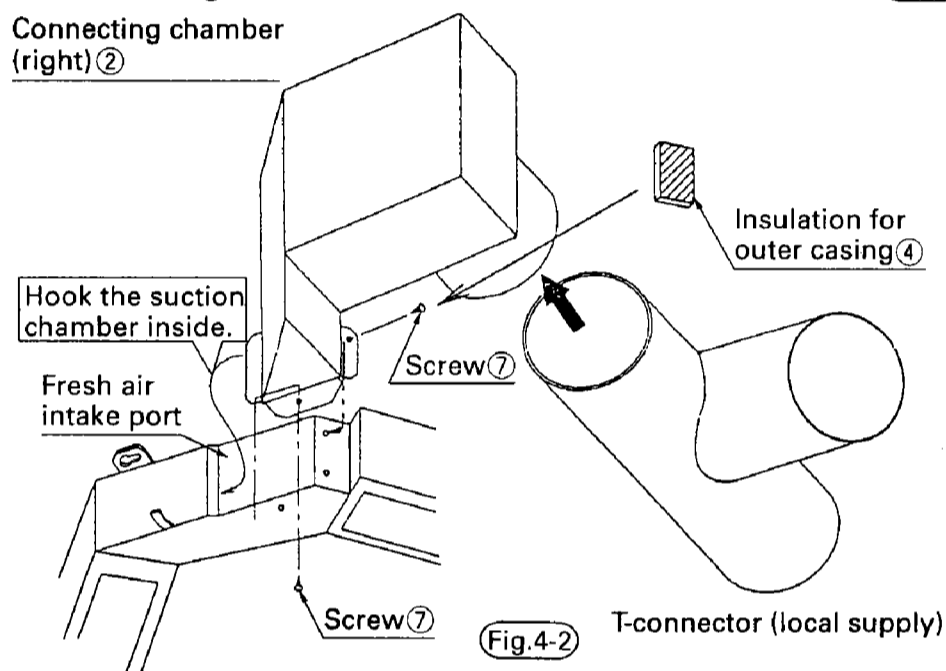
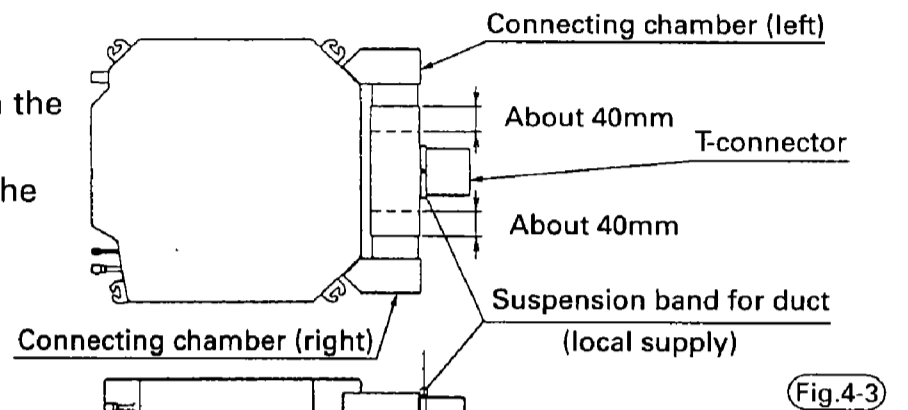
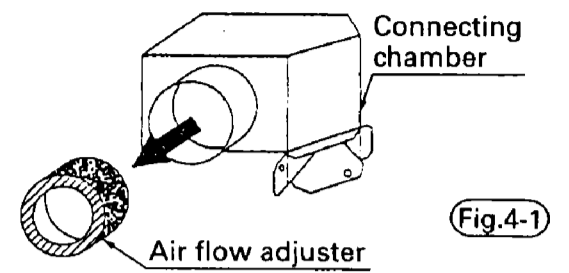
- Install the paper patten for installation and set by screws, in order to protect the indoor unit. (In case of a new installation.)

(Refer to the following figure.)



#### ④ Installation of connecting chamber

- (1) In case of KDDJ55F160, remove the air flow adjuster from the connecting chamber.  
(From both side) (Figure 4-1)  
(The air flow adjuster removed from the connecting chamber should be thrown away.)
- (2) Hook the connecting chamber(right) ② to the suction chamber and fix with two screws ⑦ in the kit. (Figure 4-2)
- (3) Insert the T-connector into the duct connecting port of the connecting chamber until the end. (Figure 4-2)
- (4) Install the connecting chamber (left) ③ in the same manner as in (2).
- (5) Slide the T-connector to overlap with the connecting chamber of both side for about 40mm each.
- (6) Suspend the T-connector with duct band to reduce the weight load on the connecting chamber. (Figure 4-3)  
The distance between the lower face of the connecting chamber and the ceiling face should be about 80mm.
- (7) Attach the insulation ④ for outer casing to cover the screws to fix the connecting chamber in item (2) and (4) of the above. (Figure 4-2)

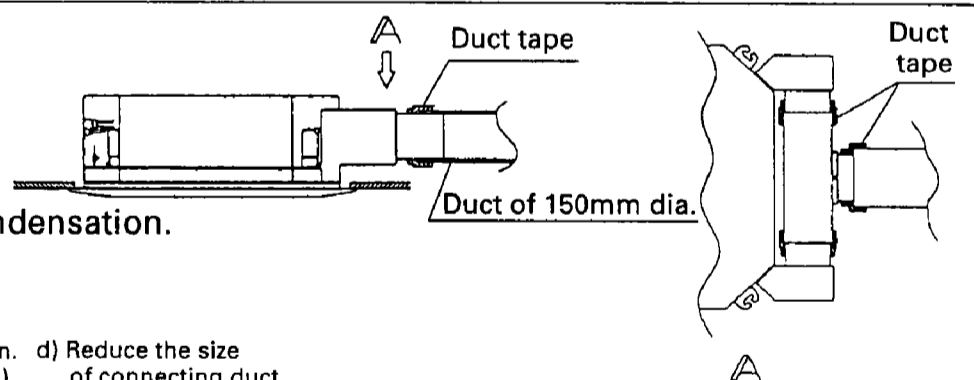


[How to attach the sealing material when the fresh air is taken from one side.]

- Secure the edge of the sealing material to the inside of the suction chamber and fix to the suction chamber with the screws.  
After fixing the sealing material, attach the insulation for outer plate ④.

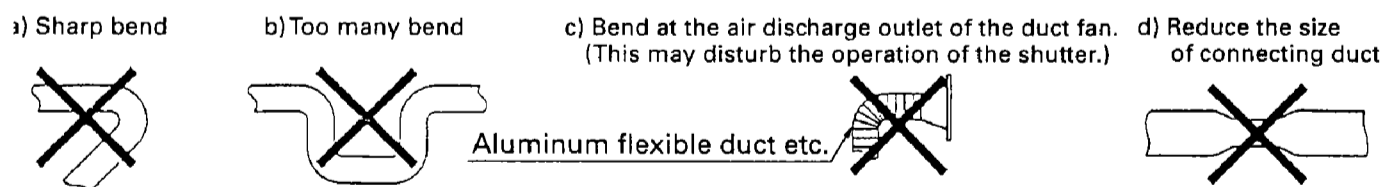
#### ⑤ Connection of duct < Duct: Nominal diameter of 150mm >

- (1) Install the duct according to the following procedure.
  - Insert the duct into the adapter of duct fan and connect to the t-connector.
- (2) Wind the tape around the connection in order to prevent the air leakage.



##### • Caution

- Be sure to insulate the duct and the T-connector to prevent the condensation.
- Never install the duct as follows.



1. Observe the local building code or fire code, which may require to use the noncombustible duct.
2. When the duct passes through the enclosure constructed of combustible material, the local fire code may require to install the fire damper and etc.
3. When you use the metal duct and passes through the wooden wall, the local code may require to put the electrical insulation between the duct and wall.
4. The outside duct should be installed in the way the duct inclines toward the outside, in order to prevent the penetration of rain water.
5. Install the net on the air inlet located outside in order to prevent the penetration of a small animal such as bird or the insect.

#### ⑥ Installation of decoration panel

Refer to the installation manual included in the decoration panel.  
Be sure there is no gap between the decoration panel and the unit after installation.

## 8.7 Sound absorption kit

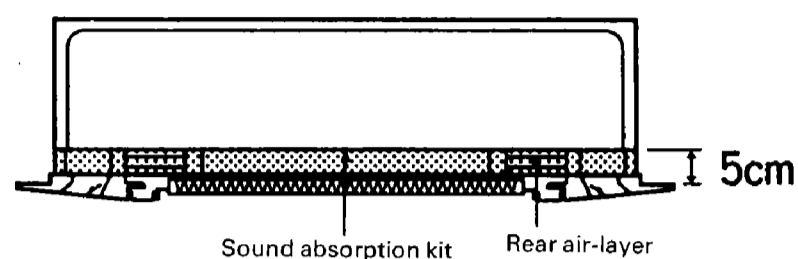
### KDDNJ55F80-160

#### ● Purposes

This kit is ideal for hospital, library, reception room etc., where the lower operating noise is requested. This kit is suggested to install on the unit larger than 60 type model.

#### ● Operating sound (when installed)

Model	Standard operating sound (Hi / Low)	Operating sound when sound absorption kit is installed. (Hi / Low)
71F	36 / 31dB	33 / 30dB
125F	42 / 36dB	38 / 35dB



#### Caution

- This kit can only be installed on the cassette type (Multi-Flow) air conditioner.
- Be sure to check the model no. of the indoor unit referring the table on the right.
- Refer to the installation manual of both the indoor unit and the decoration panel for its installation.

#### ● Combination table

Model Name	Applicable indoor unit
KDDNJ55F80	FH(Y)C35~71F FXYF32K~63K
KDDNJ55F160	FH(Y)C100~125F FXYF80K~125K

#### Contents of kit

Prior to installation check whether you have the complete kit of parts as shown below including the installation manual.

Name	① Chamber	② Screws	③ Thermal insulation	④ Installation manual
Quantity	1 set	4 piece	4 pieces	1 pc
Shape		 M5 x 30		

#### Tools required for the installation

Screw driver ⊕ ⊖  
Spanner and etc.

### ① Preparation of indoor unit

- It is required to make a setting on the indoor unit, when the sound absorption kit is installed.

Set the remote controller to the field setting mode and change the setting position no. as shown on the right.

Refer to the item "How to set in the field" of the installation manual of the remote controller for its setting.

Mode no.	Setting by remote controller	
13 or 23	Setting switch no.	Setting position no.
	5	01

### ② Installation of the chamber

(1) Remove the decoration panel. (This is not required if it is a new installation.)

- Remove the decoration chamber in the reverse step when it is installed. (Refer to the installation manual of the decoration panel for details.)

(2) Set the suction chamber to the indoor unit with 4 screws ② (M5 x 30).

#### Fig.2-1

(If the indoor unit is already installed, set the suction chamber temporarily by using the two temporary hook.)

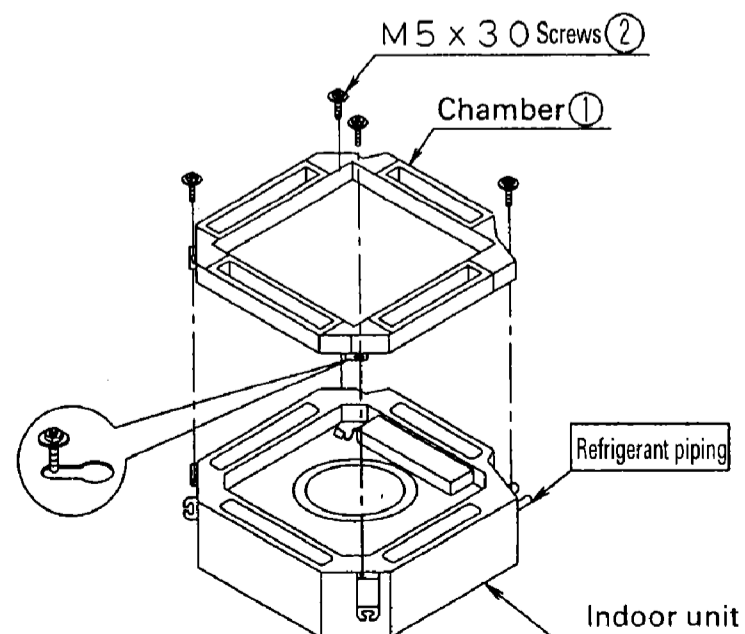


Fig.2-1

● Step for temporary setting (Fig.2-2)

(2-1) Set the screws ② (M5×30) to the indoor unit temporarily. (2 places)

(2-2) Set the suction chamber temporarily.

(Direct the suction chamber to fit the shape of the refrigerant piping part and the drain piping part of the indoor unit.)

(2-3) Set the remaining two screws ② (M5×30) to the indoor unit and fasten all the screw tightly.

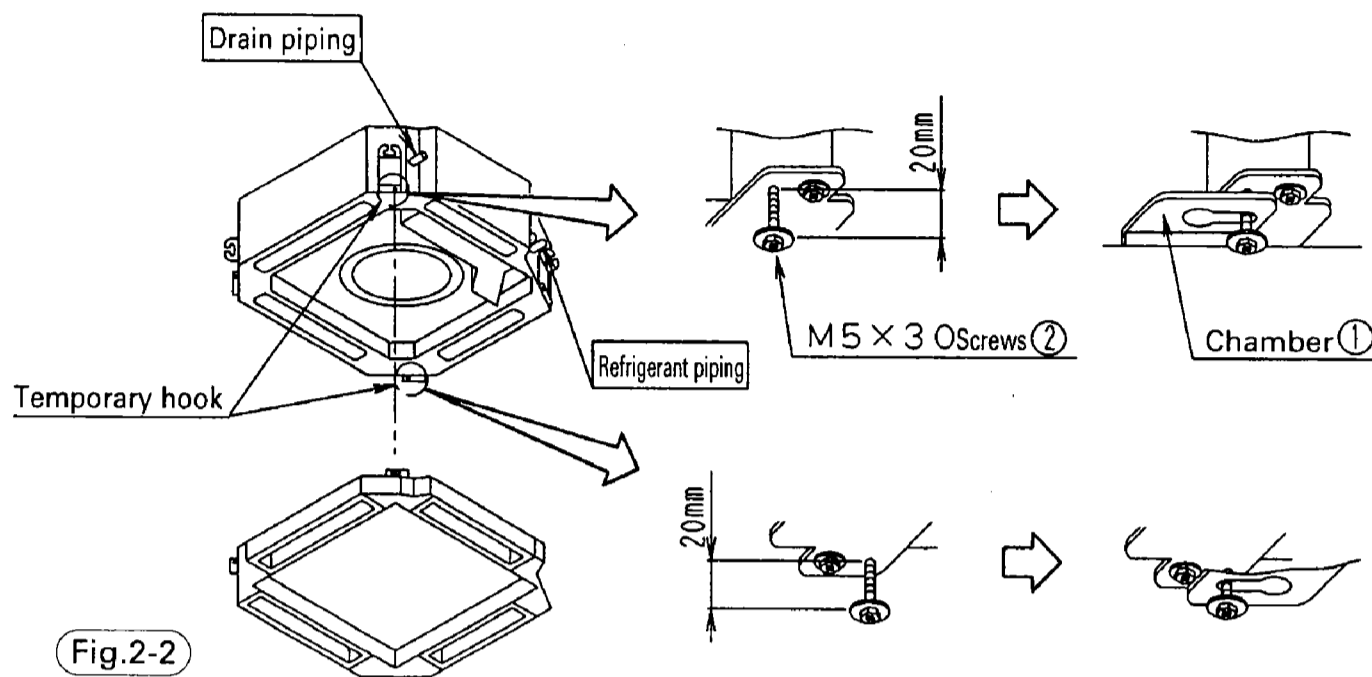


Fig.2-2

**Caution**

- Attach the suction chamber to the indoor unit and tighten the 4 screws at the corner firmly so that there is no gap between the indoor unit and the suction chamber.
- Be sure the lead wire from the indoor unit is not pinched between the indoor unit and the suction chamber, when installing.

③ Installation of the indoor unit and suction chamber

- Install the indoor unit and suction chamber.

Refer to the installation manual of the indoor unit for its installation.

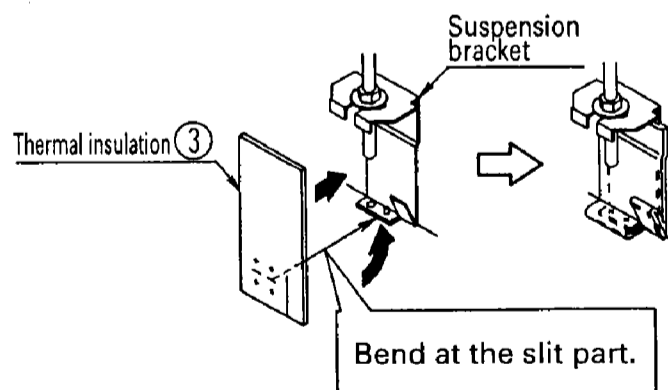
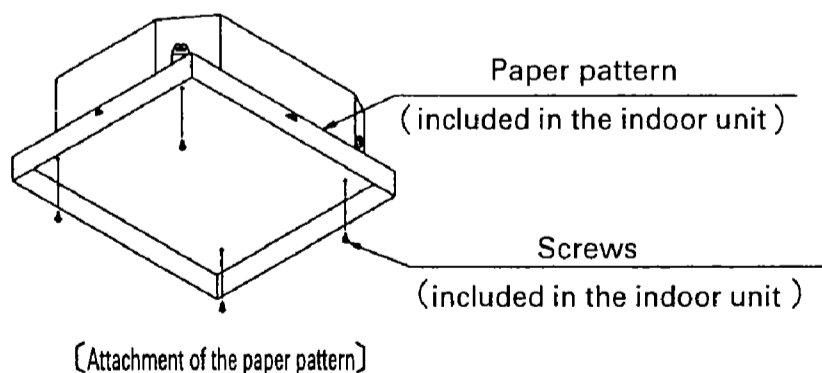
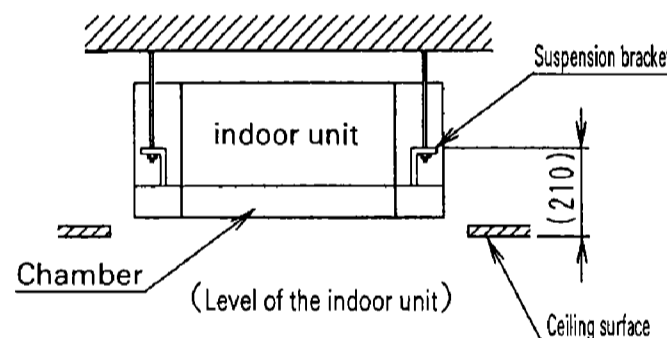
(For the height of the unit, refer to the drawing on the right.)

- Attach the thermal insulation ③ to the metal part of the suspension bracket. (4 locations) Be sure to cover the metal part of the suspension bracket completely.

- Complete the refrigerant piping and drain piping.

- Attach the paper pattern for installation to the indoor unit with screws to protect the indoor unit. (if it is a new installation.)

(Refer to the following figure.)



④ Installation of decoration panel

Refer to the installation manual of the decoration panel.

After installation, be sure to check that there is no gap between the indoor unit and the decoration panel.

## 8.8 High efficiency filter

KAFJ556F80-160

KAFJ557F80-160

KAFJ552F80-160

KAFJ553F80-160

KDDFJ55F80-160

### ● Specifications

Kit name	KAFJ556F80	KAFJ556F160	KAFJ557F80	KAFJ557F160
Item	KAFJ552F80	KAFJ552F160	KAFJ553F80	KAFJ553F160
High efficiency filter	KAFJ552F80	KAFJ552F160	KAFJ553F80	KAFJ553F160
Filter chamber for high efficiency filter	KDDFJ55F80	KDDFJ55F160	KDDFJ55F80	KDDFJ55F160
Efficiency	65% (NBS colorimetric method)		90% (NBS colorimetric method)	
Initial pressure	3.5		4.5	
Ultimate pressure loss	8		10	
Filter materials	Synthetic fiber non woven fabric		Synthetic fiber non woven fabric	
Effective life	2500 hours (at dust particle concentration of 0.15mg/m <sup>3</sup> )		1800 hours (at dust particle concentration of 0.15mg/m <sup>3</sup> )	
Applicable model	For indoor unit 35F~71F	For indoor unit 100F~125F	For indoor unit 35F~71F	For indoor unit 100F~125F

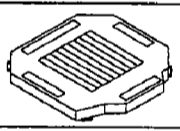


### Cautions

1. The unit should be operated with 4-way discharge when the high efficiency filter is installed.
2. The local setting by the remote controller is required when the high efficiency filter is installed. Refer to the installation manual for setting.

### High efficiency filter installation manual

- This kit can be installed on the cassette type (Multi-flow) air conditioner.
- Be sure to check the model name of the indoor unit on the table before installation.
- When installing, refer also to the installation manual of the indoor unit and the decoration panel.

#### Contents of kit

Name	High efficiency filter chamber	Screws	Thermal insulation for suspension bracket
Shape	① 	②  M5X30	③ 
Quantity	1 set	4 pieces	1 pc

#### Combination table

Model name	Model name of the indoor unit to be install	
KAFJ556F80	Sky-air	FH(Y)C35F~71F
KAFJ557F80	VRV	FXYF32K~63K
KAFJ556F160	Sky-air	FH(Y)C100F~125F
KAFJ557F160	VRV	FXYF80K~125K

### ① Preparation of indoor unit

- When you install the high efficiency filter, the setting by the remote controller is required.

Set the remote controller at the field setting mode and change the setting position number as shown on the table.

Refer to the operation manual of remote controller for the field setting.

Mode no.	Setting by remote controller	
	Setting switch no.	Setting position no.
13 or 23	0	03
	1	02

### ② Installation of high efficiency filter

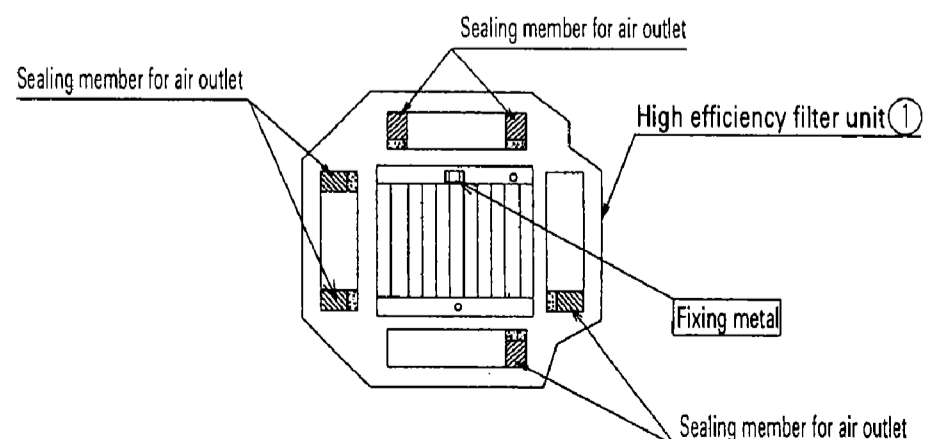
When you install the high efficiency filter on the following unit, be sure to remove the sealing member (6 positions) as shown in the drawing.

Model name of the indoor unit, which is required to be removed the sealing	
Sky-air	FH(Y)C35F~71F
VRV	FXYF32K~63K

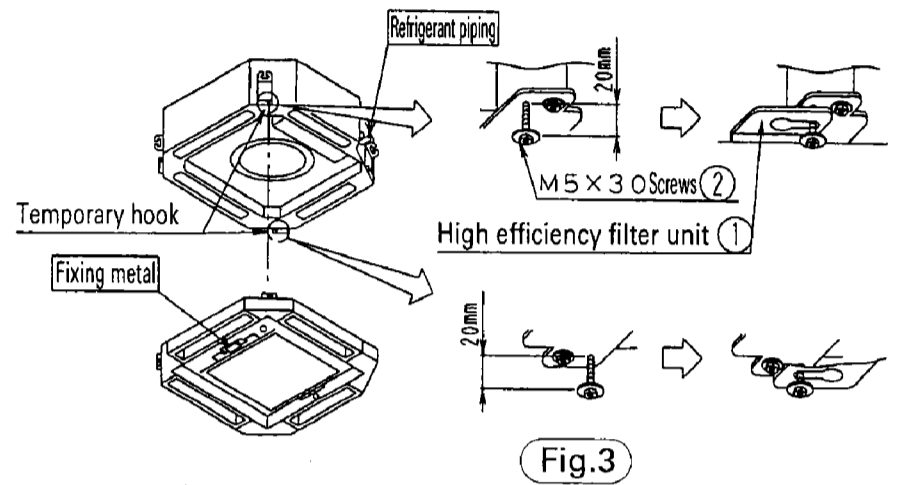
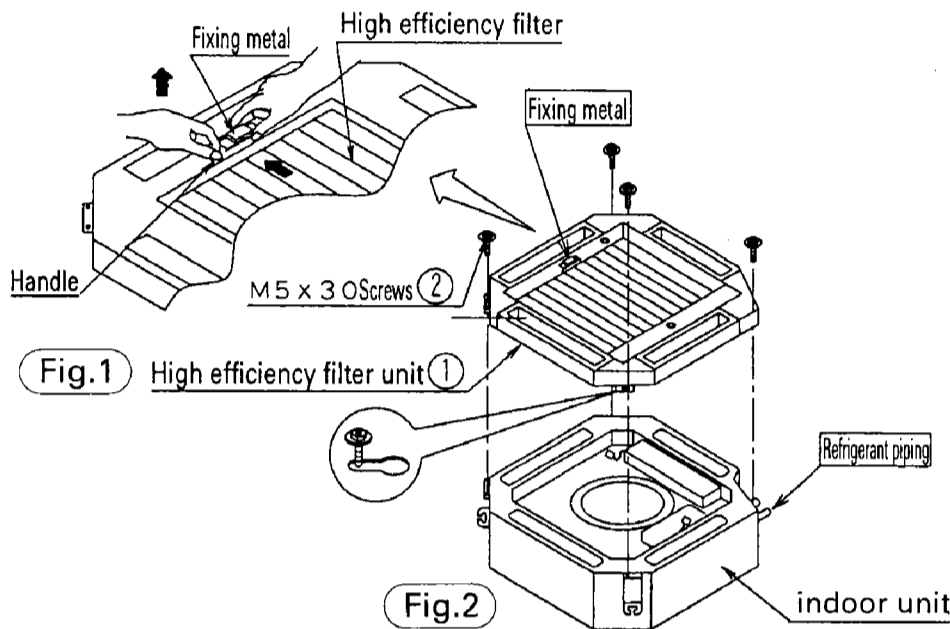
( Be sure to remove the sealing member from the above model in order to prevent the condensation on the grille. )

(1) Remove the decoration panel. (This is not required for the new installation.)

- Remove the decoration panel in the reverse step when the panel is installed.  
(Refer to the installation manual of the decoration panel for the details.)



- (2) Remove the high efficiency filter from the unit according to the following step. (Fig.1)
- Push the fixing metal to the direction shown by the arrow mark and pull up the handle.
- (3) Fix the high efficiency filter unit to the indoor unit with 4 screws (2) (M5×30). (Fig.2)
- (If it is for the indoor unit already installed, hook the high efficiency filter unit on the two screws set for temporarily.)
- Procedure for temporary setting (Fig.3)
- (3-1) Fasten the screws (2) to the indoor unit temporarily. (2 locations)
- (3-2) Set the high efficiency filter unit temporarily.
- (3-3) Set the screws to the remaining 2 locations and fasten all of 4 screws tightly.

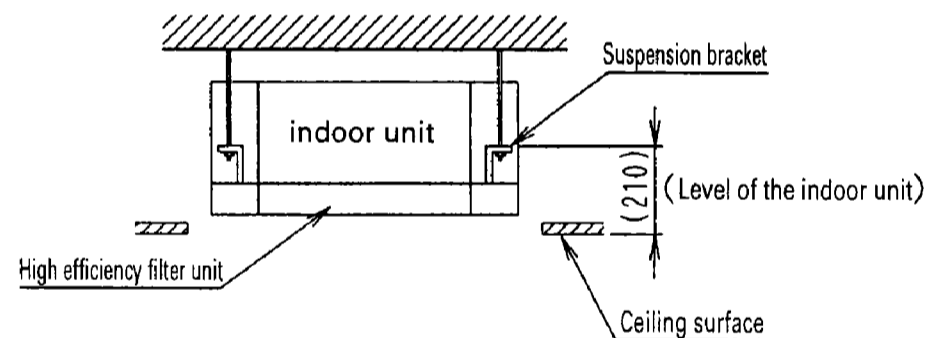


### Caution

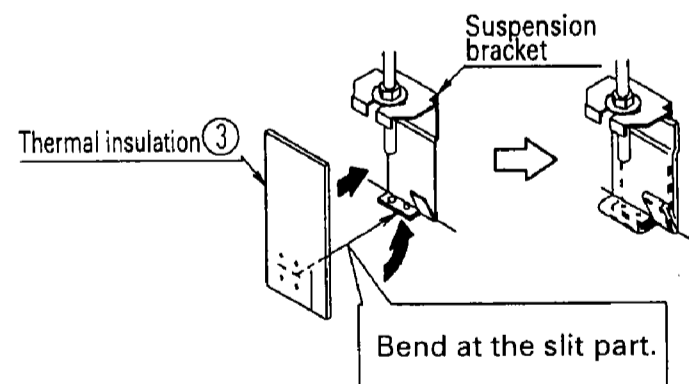
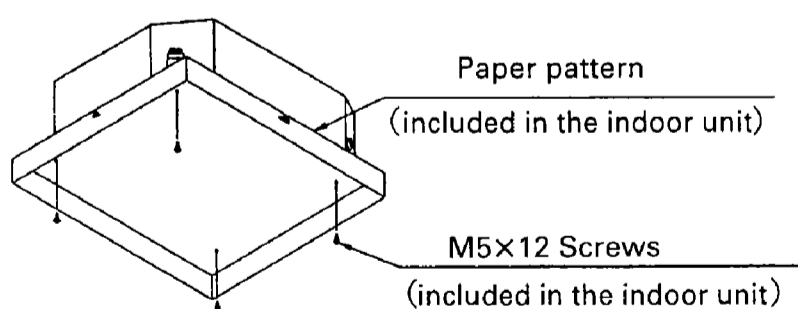
- Tighten the all of 4 screws so as to make no gap between the indoor unit and the high efficiency filter.
- Be sure that the wiring from the indoor unit is not pinched between the indoor unit and the high efficiency filter.

## ③ Installation of the indoor unit and the high efficiency filter unit

- Install the indoor unit and the high efficiency filter unit. Refer to the installation manual of the indoor unit for its installation. (For the height of the unit, refer to the drawing on the right.)
- Attach the thermal insulation (3) to the metal part of the suspension bracket. (4 locations) Be sure to cover the metal part of the suspension bracket completely.
- Complete the refrigerant piping and the drain piping.
- Attach the paper pattern for installation to the indoor unit with screws to protect the indoor unit from dirt. (If it is a new installation.) (Refer to the following drawing.)



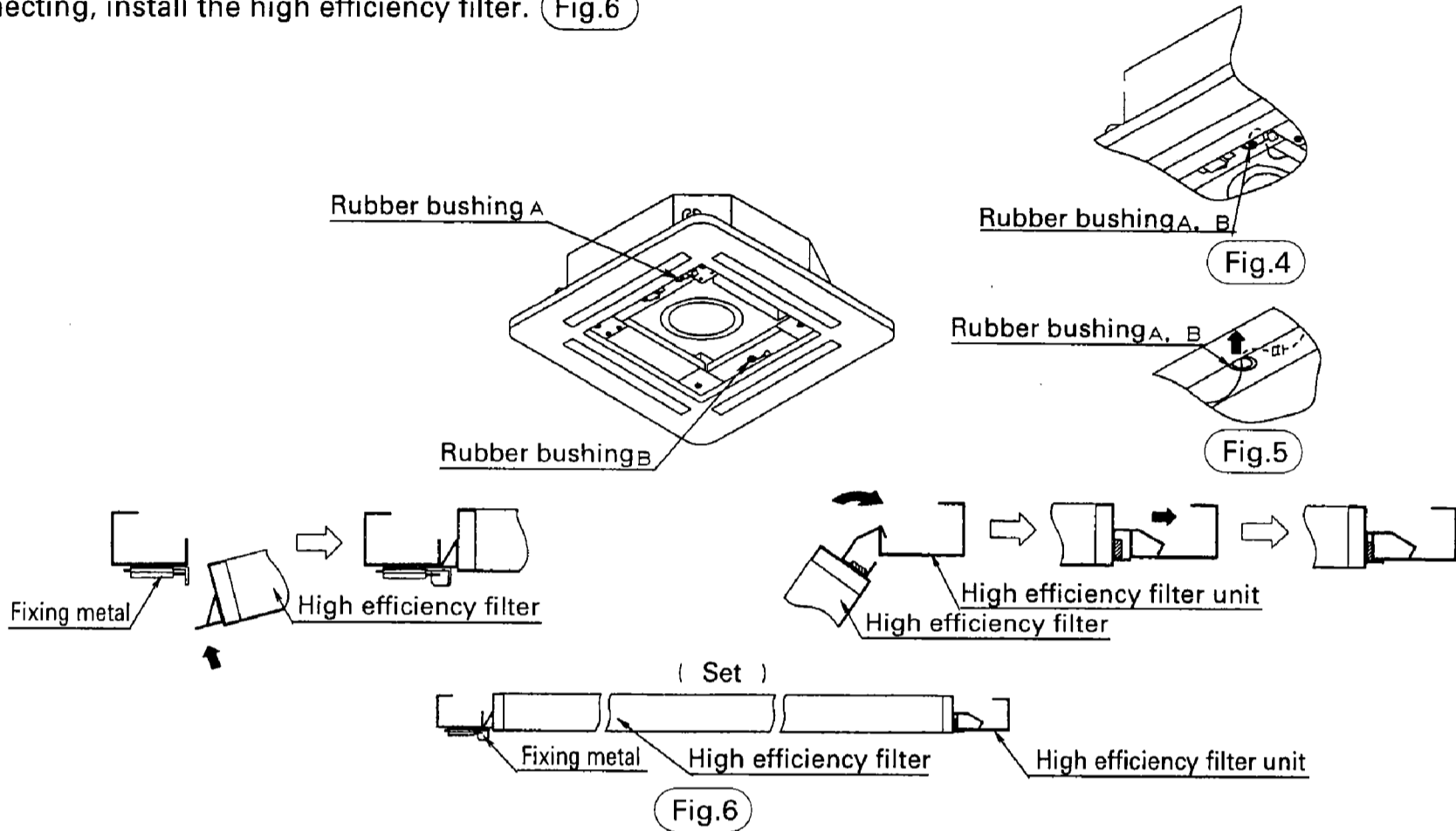
(Attachment of the paper pattern)



#### ④ Installation of the decoration panel and the high efficiency filter

- Install the decoration manual according to the installation manual of the decoration panel.
- Wiring between the indoor unit and the decoration panel
  - (1) Put the lead wire through the rubber bushing A and B of the high efficiency filter unit. (Fig.4)
  - (2) Connect the connectors according to the installation manual of the decoration panel.
  - (3) After connecting, put the connector through the rubber bushing to the indoor unit side. (Fig.5)
- Installation of the high efficiency filter
 

After connecting, install the high efficiency filter. (Fig.6)



#### In case of wireless remote controller

- Put the connector of the lead wire for signal receiver through the rubber bushing A and connect to the printed circuit board of the indoor unit. (Fig.7)
- Refer to the installation manual of the wireless remote controller for the details of wiring.

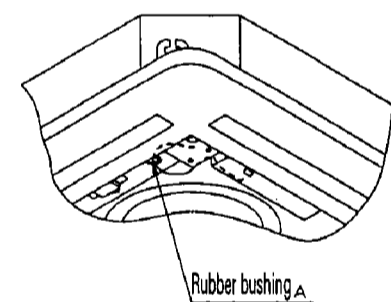


Fig.7



# High efficiency filter chamber installation manual

## KDDFJ55F80

## KDDFJ55F160

### Caution

For the installation of this kit, the high efficiency filter is also required separately. Select the high efficiency filter according to the table on the right. Keep this installation manual until the installation of the high efficiency filter is completed.




- This kit can be install on the cassette type (Multi-flow) air conditioner.
- Check the model name of the indoor unit on the table before installation.
- When installing, refer also to the installation manual of the indoor unit and the decoration panel.

### Combination table

Model name	High efficiency filter	Model name of the indoor unit to be installed	
KDDFJ55F80	KAFJ552F80 or KAFJ553F80	Sky-air	FH(Y)C35F~71F
		VRV	FXYP32K~63K
KDDFJ55F160	KAFJ552F160 or KAFJ553F160	Sky-air	FH(Y)C100F~125F
		VRV	FXYP80K~125K

### Contents of kit

Prior to installation check whether you have the complete kit of part as shown below including the installation manual.

Name	High efficiency filter chamber	Screws	Thermal insulation for suspension bracket
Shape	① 	②  M5X30	③ 
Quantity	1 set	4 pieces	1 pc

## ① Preparation of the indoor unit

- When you install the high efficiency filter, the setting by the remote controller is required.  
Set the remote controller at the field setting mode and change the setting position number as shown on the table in the right.  
Refer to the operation manual of remote controller for the field setting.

Mode no.	Setting by remote controller	
13 or 23	Setting switch no.	Setting position no.
	0	03
	1	02

## ② Installation of high efficiency filter chamber

When you install the high efficiency filter chamber on the following unit, be sure to remove the sealing member (6 positions) as shown in the right drawing.

Model name of the indoor unit, which is required to be removed the sealing member.	
Sky-air	FH(Y)C35F~71F
VRV	FXYP32K~63K

Be sure to remove the sealing member from the above model in order to prevent the condensation on the grille.

(1) Remove the decoration panel. (This is not required for the new installation.)

- Remove the decoration panel in the reverse step when the panel is installed.  
(Refer to the installation manual of the decoration panel for the details.)

(2) Fix the high efficiency filter chamber to the indoor unit with 4 screws ② (M5X30). (Fig.1)

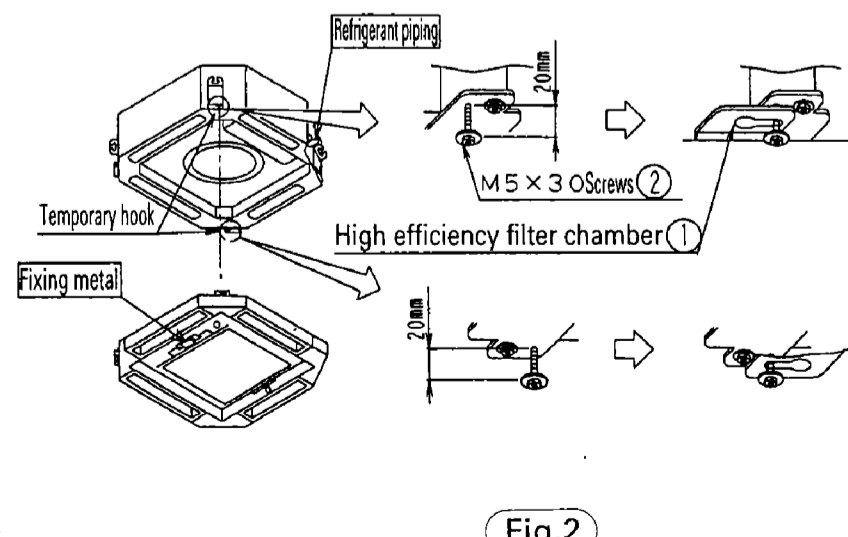
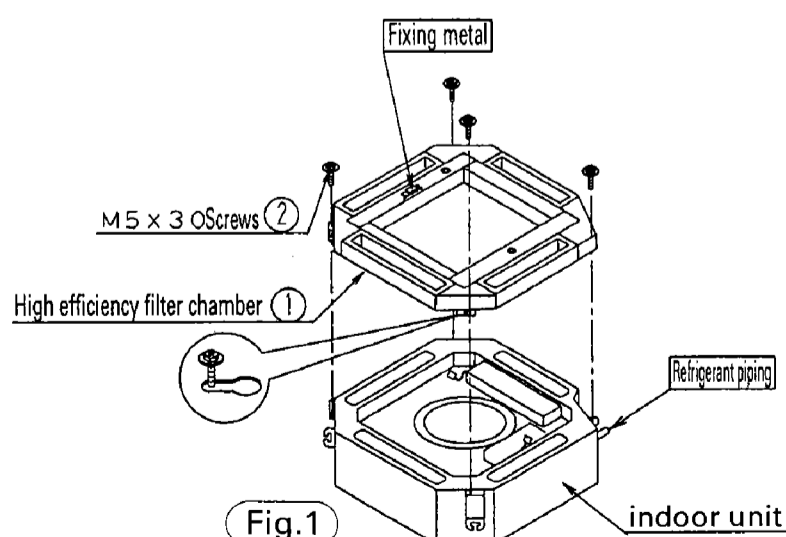
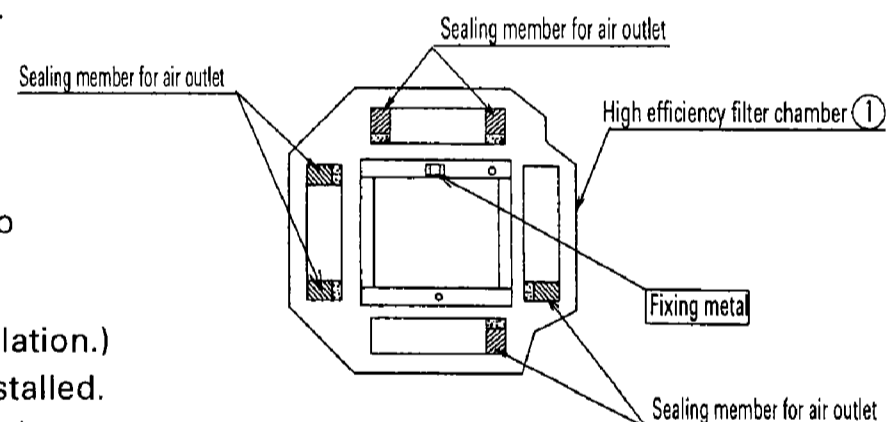
(If it is for the indoor unit already installed, hook the high efficiency filter chamber on the two screws set for temporarily.)

- Procedure for temporary setting (Fig.2)

(2-1) Fasten the screws ② to the indoor unit temporarily. (2 locations)

(2-2) Set the high efficiency filter chamber temporarily.

(2-3) Set the screws to the remaining 2 locations and fasten all of 4 screws tightly.

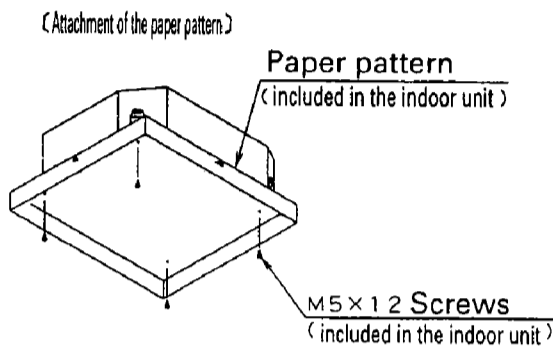
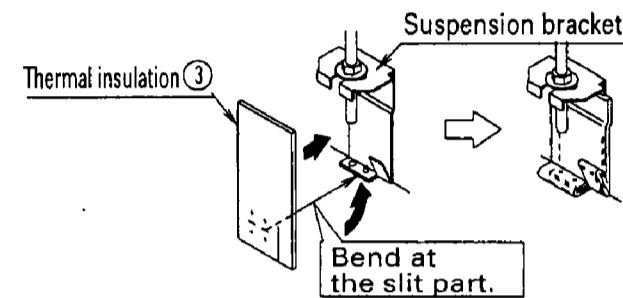
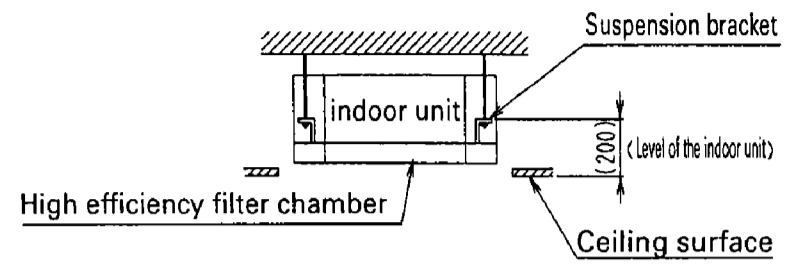


### Caution

- Fasten the all of 4 screws tightly so as to make no gap between the indoor unit and the high efficiency filter chamber.
- Be sure that the wiring from the indoor unit is not pinched between the indoor unit and the high efficiency filter chamber.

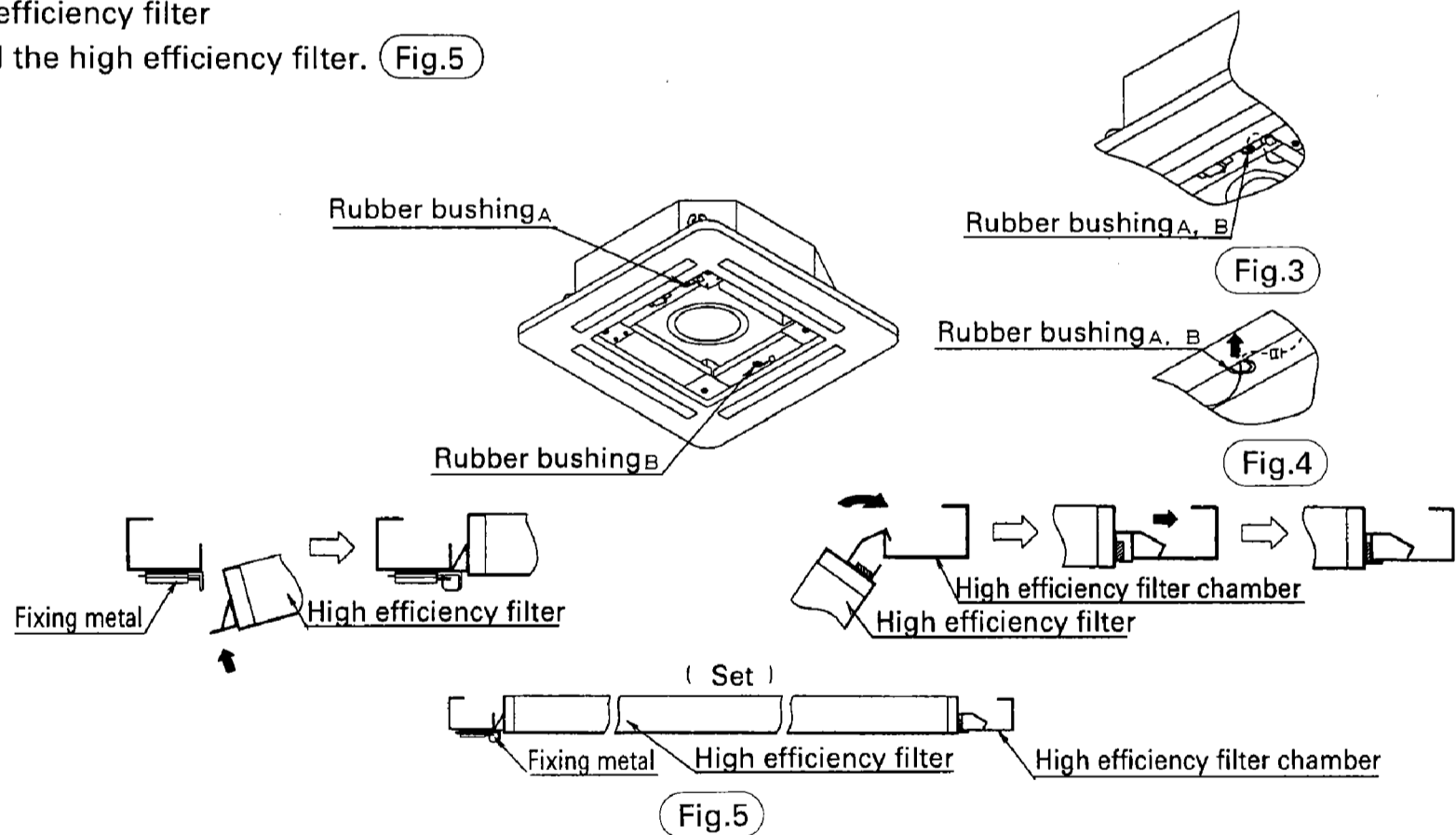
### ③ Installation of the indoor unit and the high efficiency filter chamber

- install the indoor unit and the high efficiency filter chamber. Refer to the installation manual of the indoor unit for its installation.  
(For the height of the unit, refer to the drawing on the right.)
- Attach the thermal insulation to the metal part of the suspension bracket. (4 locations) Be sure to cover the metal part of the suspension bracket completely.
- Complete the refrigerant piping and the drain piping.
- Attach the paper pattern for installation to the indoor unit with screws to protect the indoor unit from dirt. (If it is a new installation.)  
(Refer to the following drawing.)



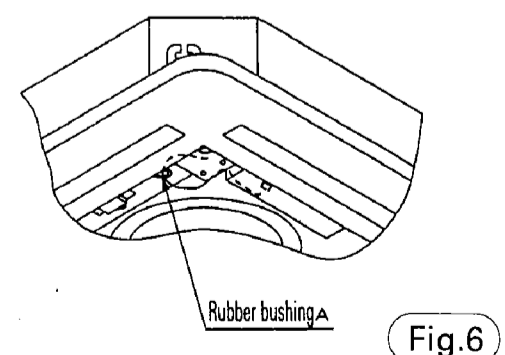
### ④ Installation of the decoration panel and the high efficiency filter

- Install the decoration manual according to the installation manual of the decoration panel.
- Wiring between the indoor unit and the decoration panel
  - (1) Put the lead wire through the rubber bushing A and B of the high efficiency filter chamber. (Fig.3)
  - (2) Connect the connectors according to the installation manual of the decoration panel.
  - (3) After connecting, put the connector through the rubber bushing to the indoor unit side. (Fig.4)
- Installation of the high efficiency filter  
After connecting, install the high efficiency filter. (Fig.5)



#### In case of wireless remote controller

- Put the connector of the lead wire for signal receiver through the rubber bushing A and connect to the printed circuit board of the indoor unit. (Fig.6)
- Refer to the installation manual of the wireless remote controller for the details of wiring.



## 8.9 Replacement long-life filter – KAFJ551F80·160 KAFJ550F80·160

### ● Specifications (Resin net)

Item	Kit name	KAFJ551F80	KAFJ551F160
Effective life and Average efficiency		2500 hours (at dust particle concentration of 0.15mg/m <sup>3</sup> ), 45% (by weight method)	
Filter materials		Mold prevention resin net	Mold prevention resin net
Number required per unit		1	2
Applicable model		For indoor unit 35F~71F	For indoor unit 100F~125F

### ● Specification (Non woven fabric)

Model	Item	KAFJ550F80	KAFJ550F160
Effective life and Average efficiency		2500 hours (at dust particle concentration of 0.15mg/m <sup>3</sup> ), 45% (by weight method)	
Filter materials		Synthetic non woven fabric	Synthetic non woven fabric
Number required per unit		1	2
Applicable model		For indoor unit 35F~71F	For indoor unit 100F~125F

Note; KAFJ550F80 · 160 can be used repeatedly up to 10 times after washing by water.

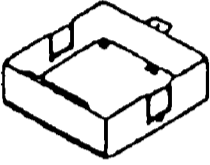
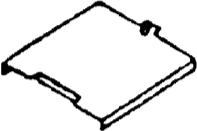



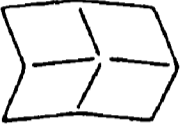
## 8.10 Installation box for adaptor PCB — KRP1B94

### Notes

- This kit can be used with ceiling-mounted cassette Multiflow type indoor units.
- One kit is required for each adaptor PC board.

### Accessories

Check the following accessories are included in the kit.

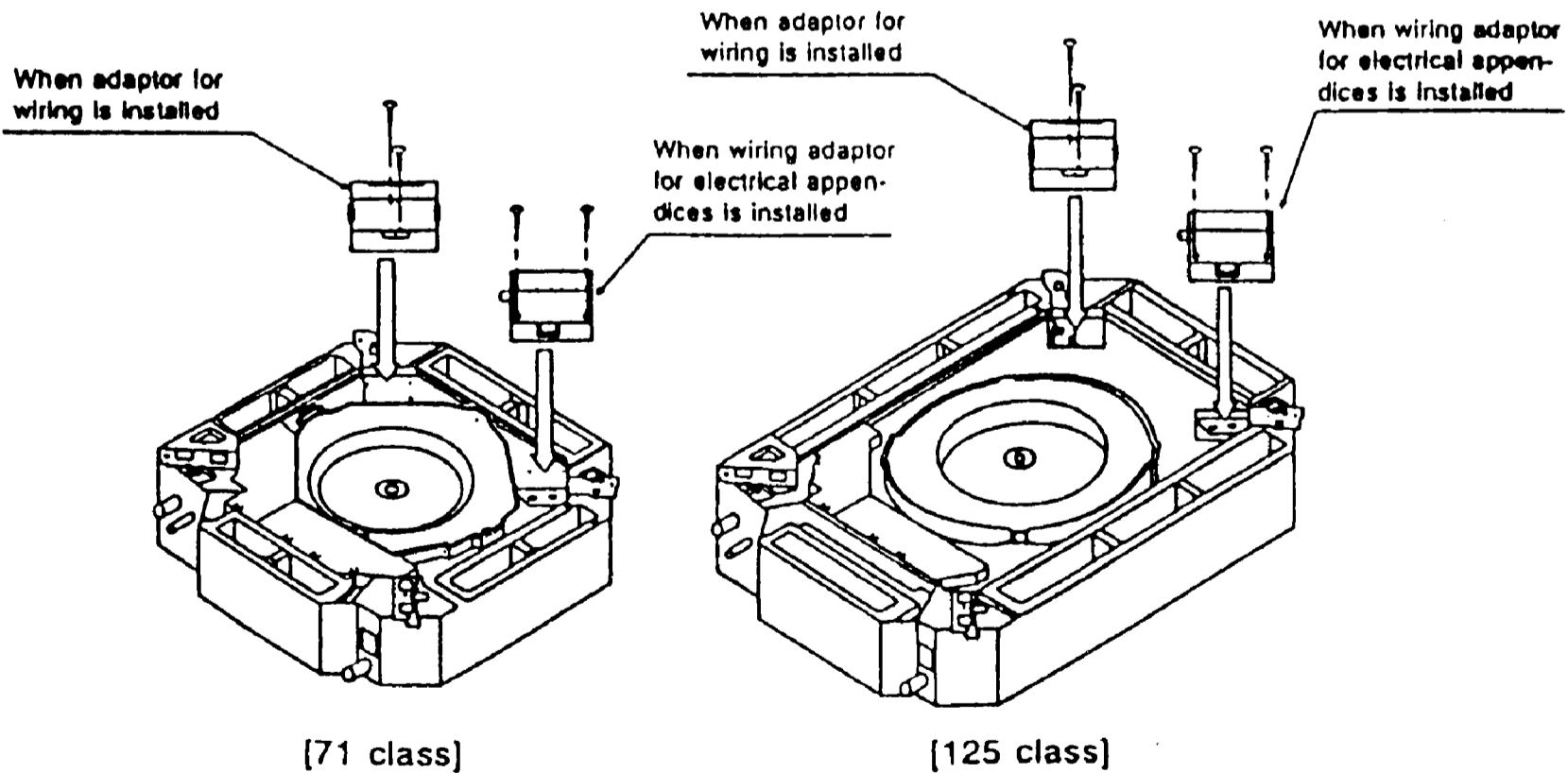
Name	Installation box	Lid for installation box	Screws for installation box	Screws for anchor the lid	Cord staker	Installation manual
Shape			 M4 x 8	 M4 x 8 (Hexagon head)		
Quantity	x 1	x 1	x 2	x 1	x 4	x 1

### Applicable adaptor PCB

Adaptor PCB	Kit
Adaptor for wiring	KRP1B57
Wiring adaptor for electrical appendices	KRP4A53

## 1 Mounting on the indoor unit

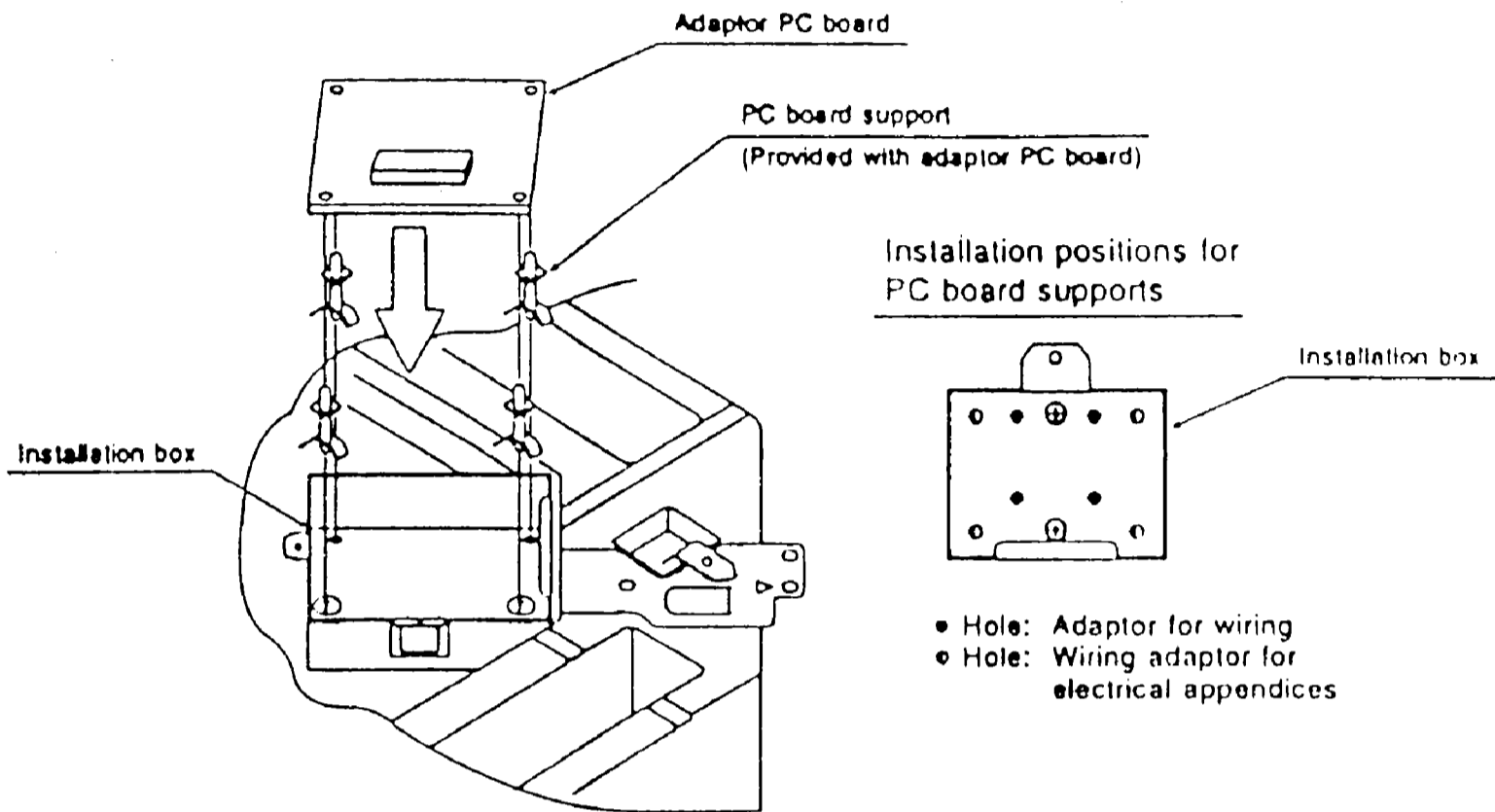
- Attach the installation box on the indoor unit with the two provided screws. This must be done before attempting to attach the adaptor PC board.



## 2 Attaching the adaptor PCB

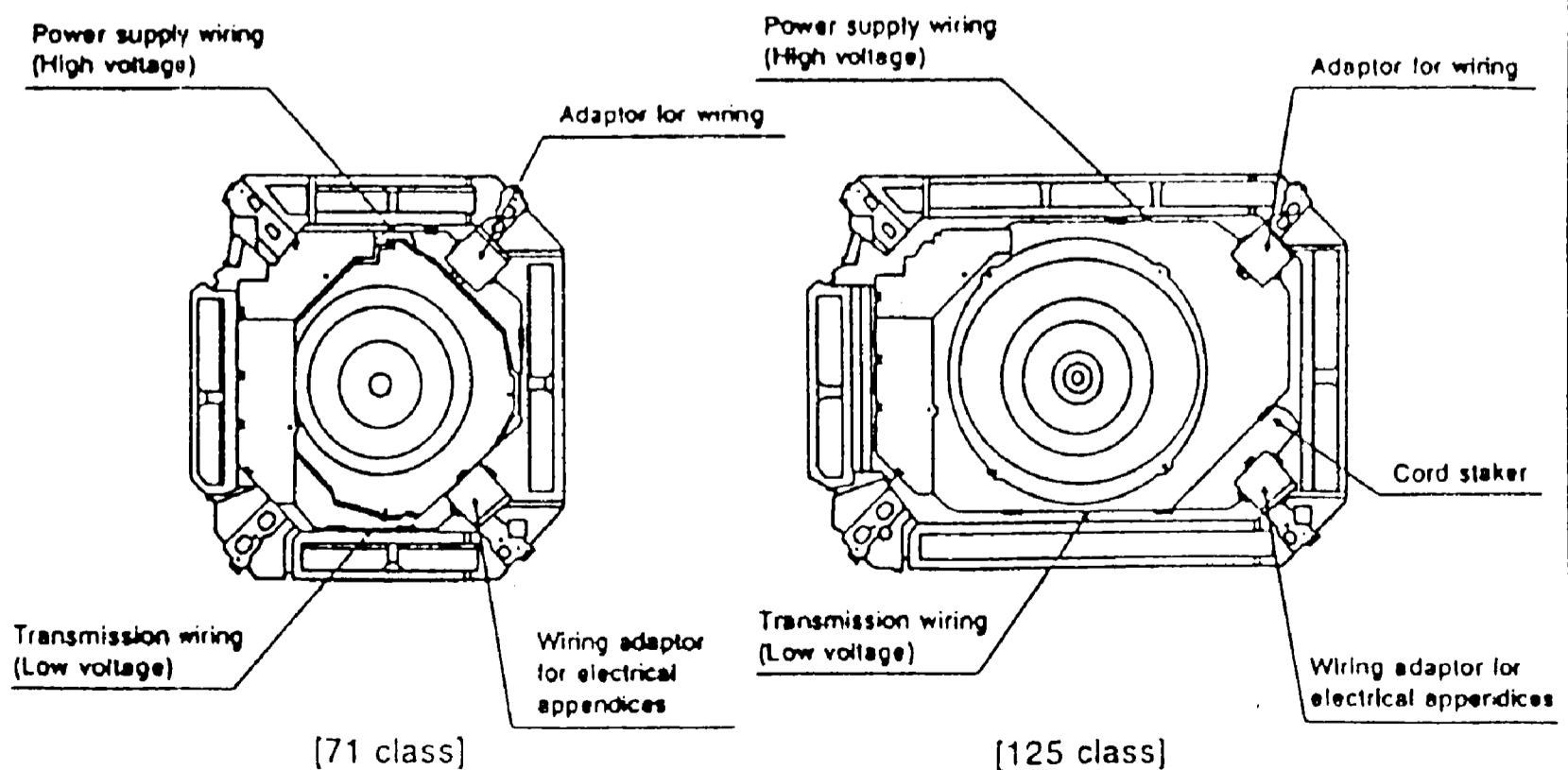
( Refer also to the installation manual provided with the adaptor PCB. )

- Fit the four PC board supports inside the holes on the installation box. The supports are provided with the adaptor PC board.
- Fit the PC board on the supports.



## 3 Wiring

- Wire the adaptor PCB as explained in the installation manual provided with the adaptor PCB.
- When finished wiring, anchor wires with the provided cord staker as shown in the below drawing. Be careful wires are not twisted or bent.
- Check wiring and then attach the lid to the installation box with the provided screws.

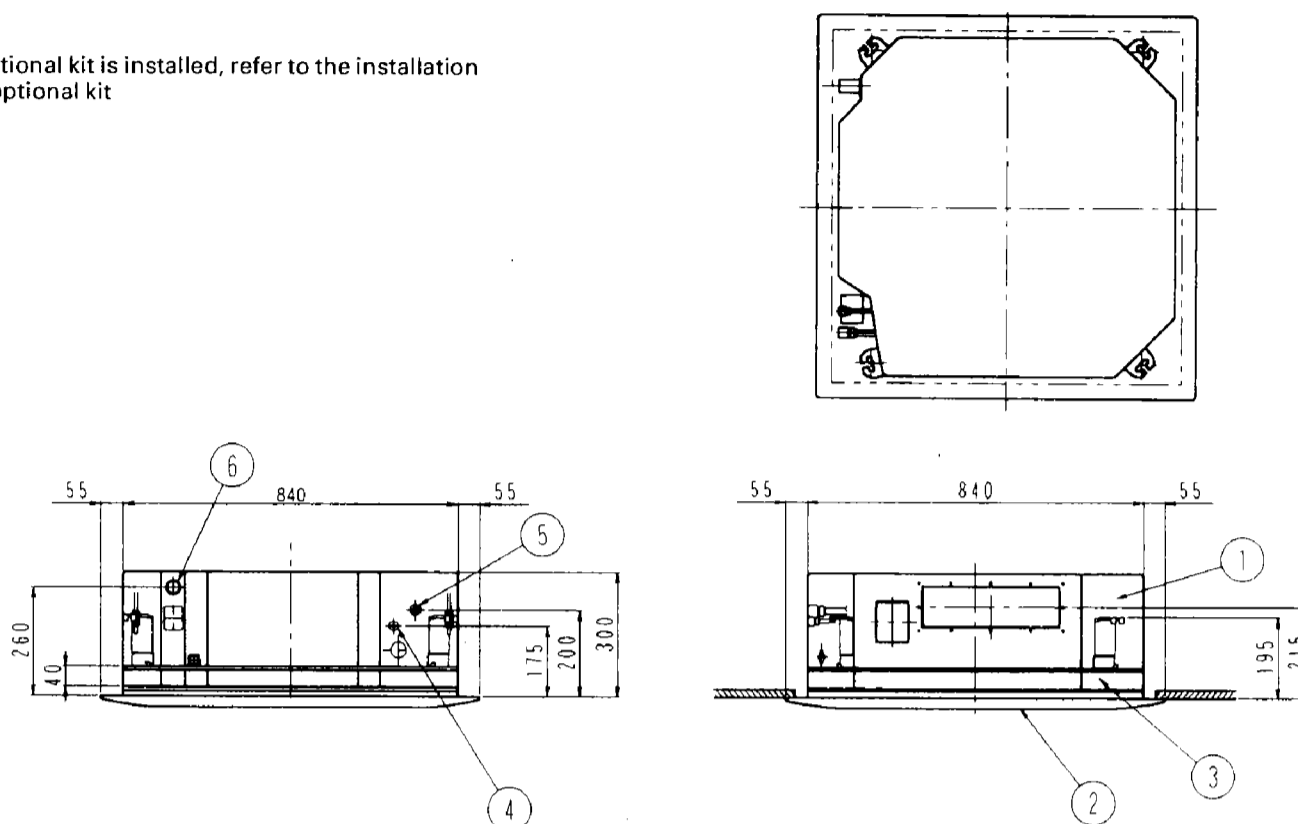


## 8.11 Optional kit installation drawing

### High efficiency filter KAFJ556F80 · 557F80

#### ● FH(Y)C35F~71F

Note: When other optional kit is installed, refer to the installation drawing of its optional kit

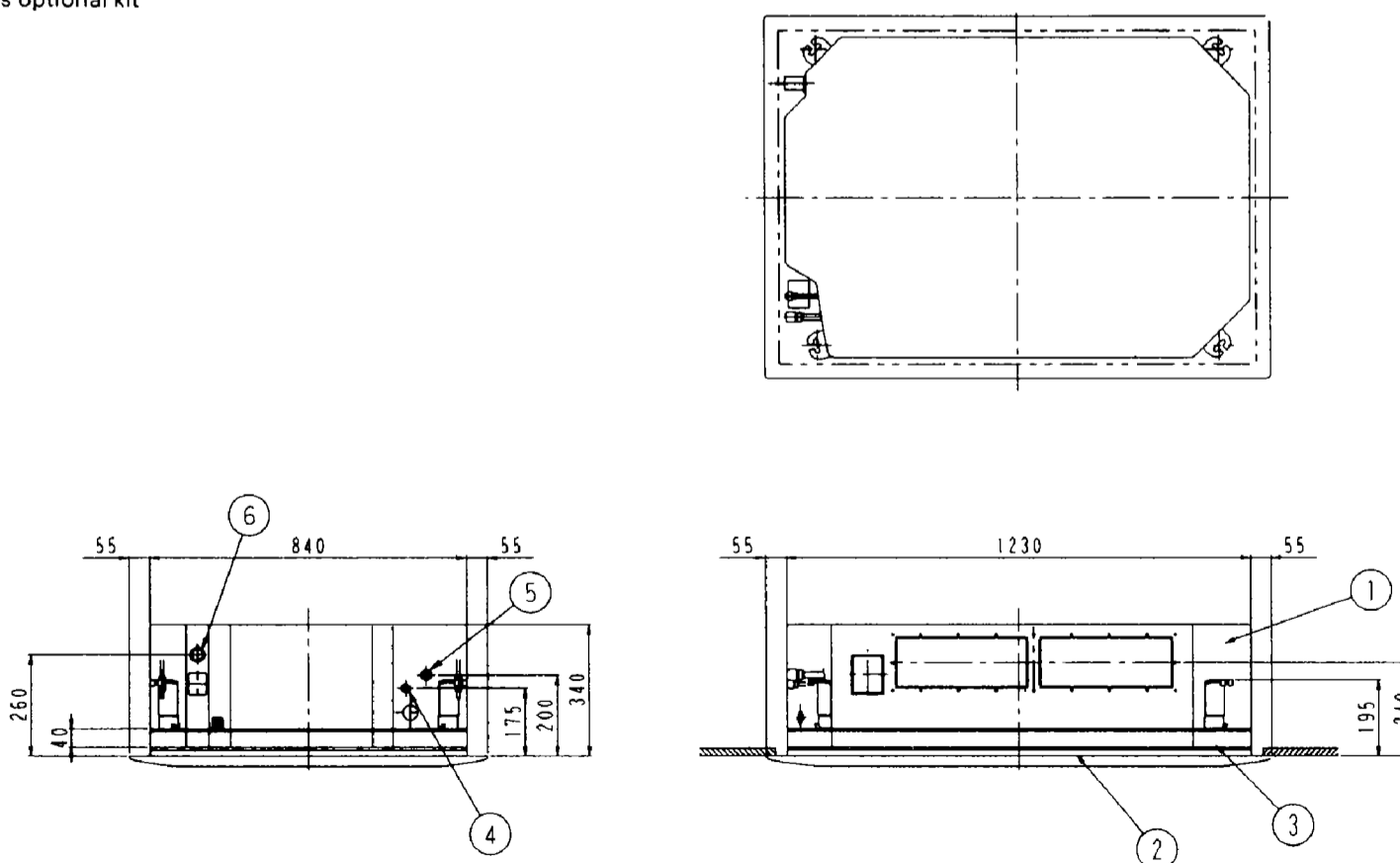


6	Drain pipe connection	
5	Gas pipe connection	
4	Liquid pipe connection	
3	High efficiency filter	
2	Decoration panel	
1	Indoor unit	
Number	Name	Description

### KAFJ556F160 · 57F160

#### ● FH(Y)C100F~125F

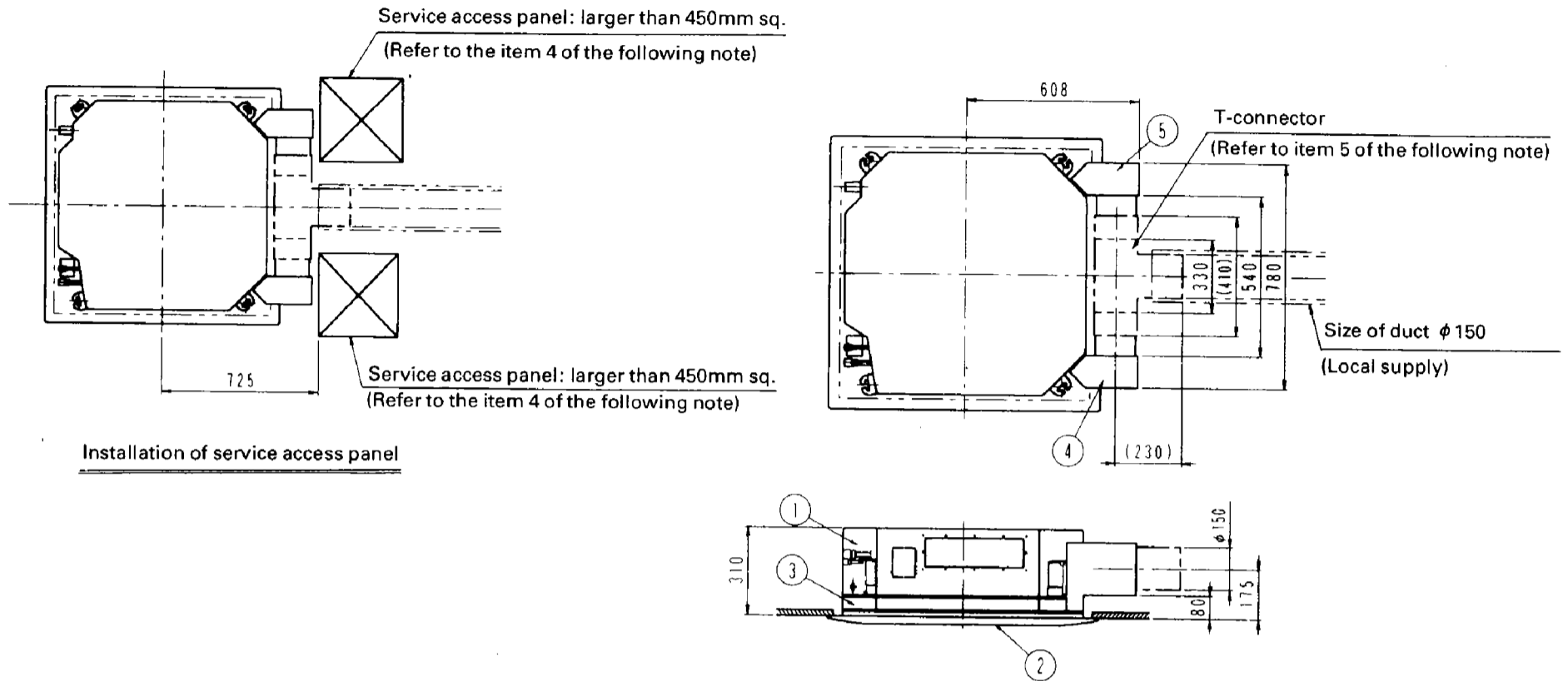
Note: When other optional kit is installed, refer to the installation drawing of its optional kit



6	Drain pipe connection	
5	Gas pipe connection	
4	Liquid pipe connection	
3	High efficiency filter	
2	Decoration panel	
1	Indoor unit	
Number	Name	Description

# Fresh air intake kit (without duct fan) KDDJ55F80

● FH(Y)C35F~71F



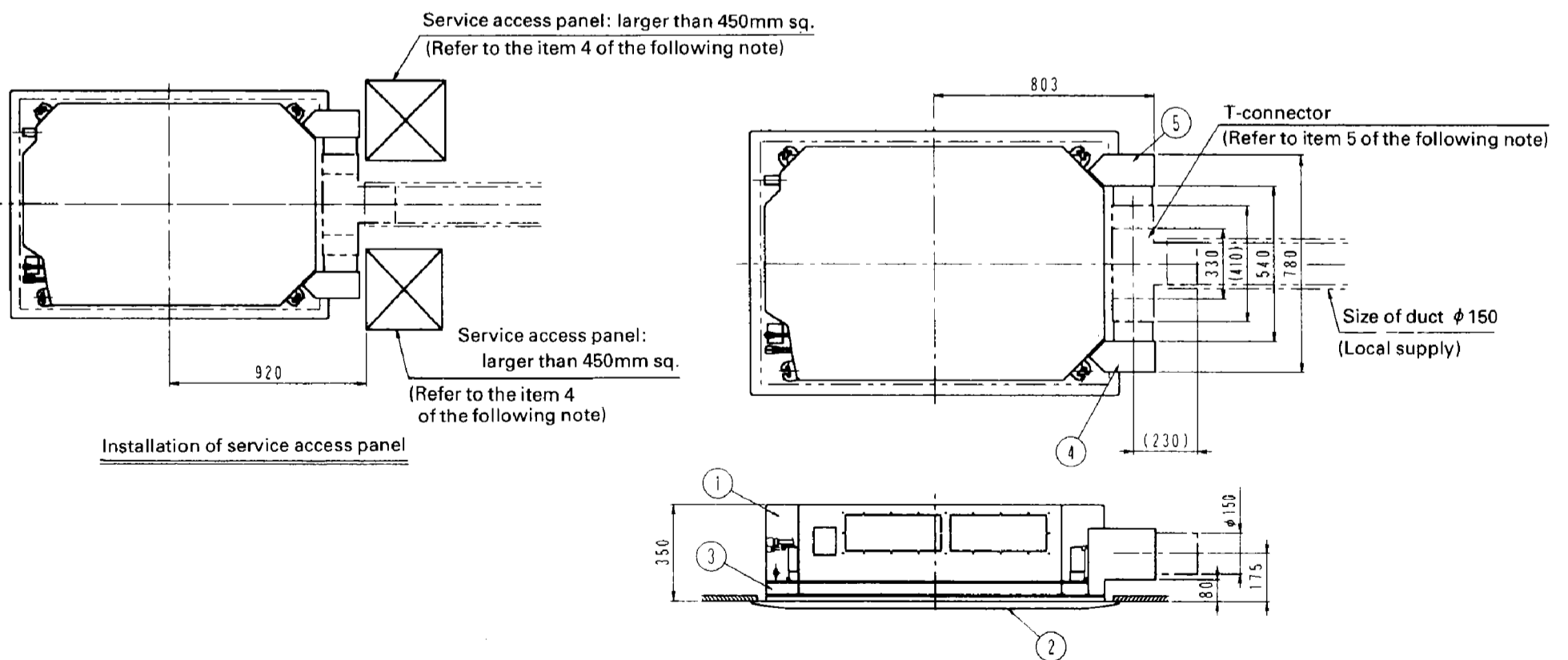
**Note:**

1. The length of the duct should not exceed 4 meter. If it exceeds 4 meters, it is required to install the duct fan.
2. When other optional kit is installed, refer to the installation drawing of its optional kit.
3. When this optional kit is installed, the service access panel should be provided.
4. Install the service access panel on either side shown above.
5. It is recommended to use the optional T-connector model YTP150A15. [the dimension shows in ( . )]

5	Connecting chamber (Left)	
4	Connecting chamber (Right)	
3	Suction chamber	
2	Decoration panel	
1	Indoor unit	
Number	Name	Description

# KDDJ55F160

● FH(Y)C100F~125F



**Note:**

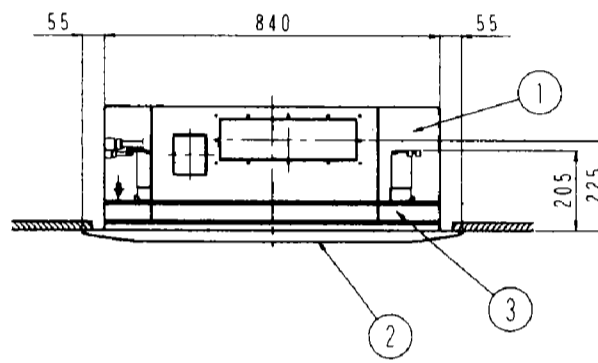
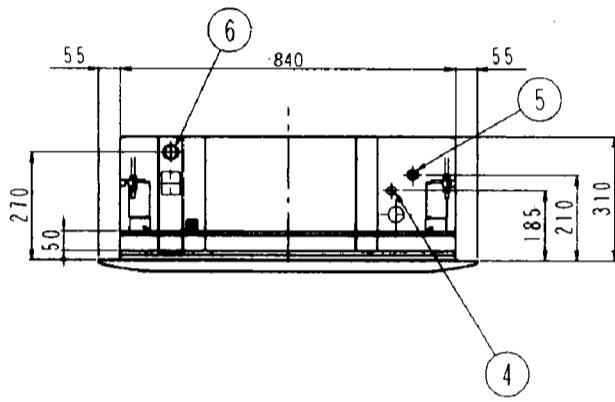
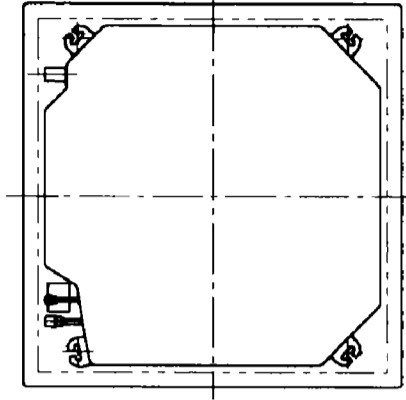
1. The length of the duct should not exceed 4 meter. If it exceeds 4 meters, it is required to install the duct fan.
2. When other optional kit is installed, refer to the installation drawing of its optional kit.
3. When this optional kit is installed, the service access panel should be provided.
4. Install the service access panel on either side shown above.
5. It is recommended to use the optional T-connector model YTP150A15. [the dimension shows in ( . )]

5	Connecting chamber (Left)	
4	Connecting chamber (Right)	
3	Suction chamber	
2	Decoration panel	
1	Indoor unit	
Number	Name	Description

# Sound absorption kit KDDNJ55F80

● FH(Y)C35F~71F

Note: When other optional kit is installed, refer to the installation drawings of its optional kit.

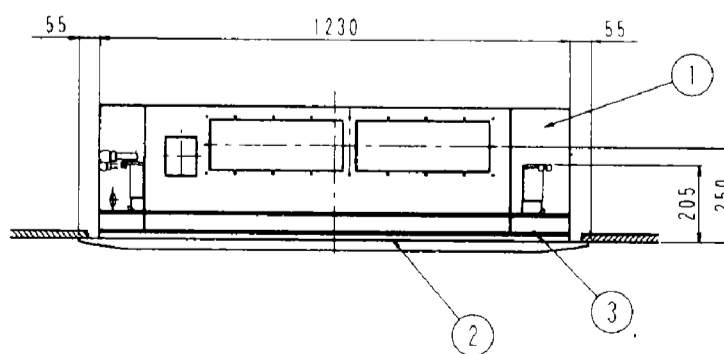
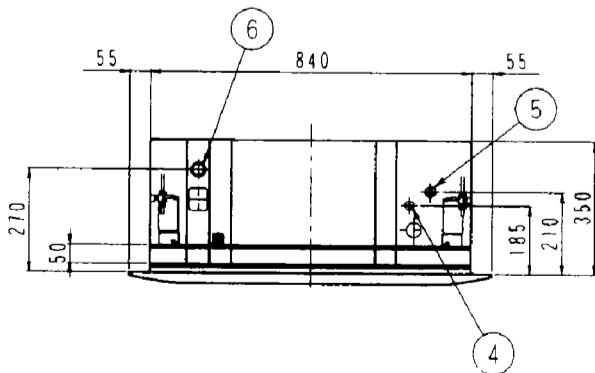
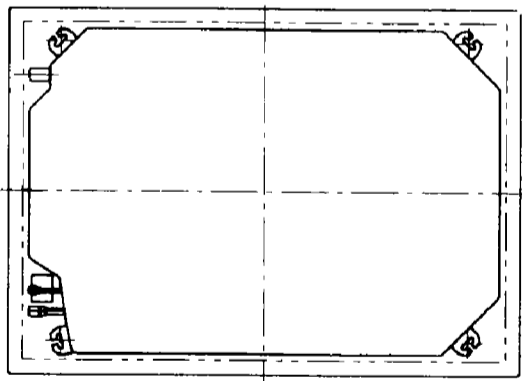


6	Drain pipe connection	
5	Gas pipe connection	
4	Liquid pipe connection	
3	Sound absorbing kit	
2	Decoration panel	
1	Indoor unit	
Number	Name	Description

# KDDNJ55F160

● FH(Y)C100F~125F

Note: When other optional kit is installed, refer to the installation drawings of its optional kit.



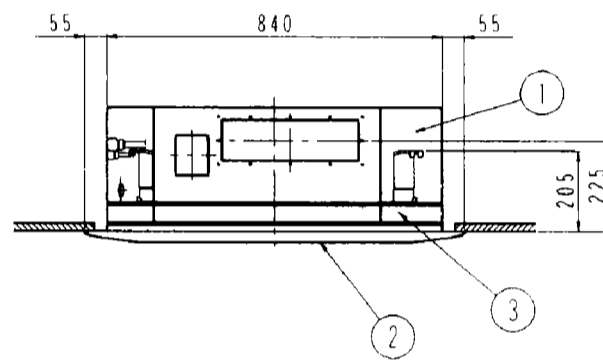
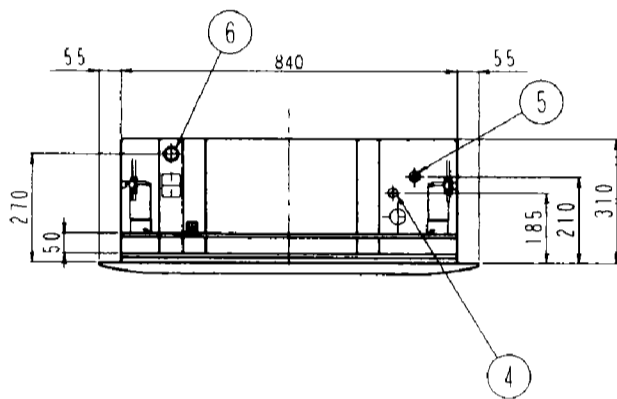
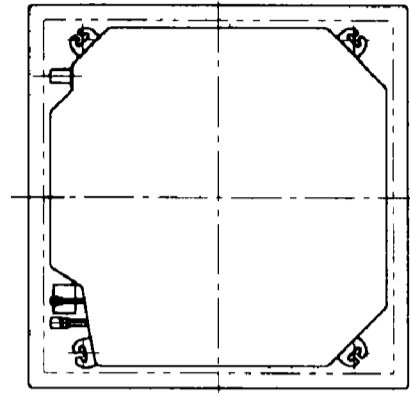
6	Drain pipe connection	
5	Gas pipe connection	
4	Liquid pipe connection	
3	Sound absorbing kit	
2	Decoration panel	
1	Indoor unit	
Number	Name	Description



# Lifter style suction grille KDVJ55F80

● FH(Y)C35F~71F

Note: When other optional kit is installed, refer to the installation drawing of its optional kit.

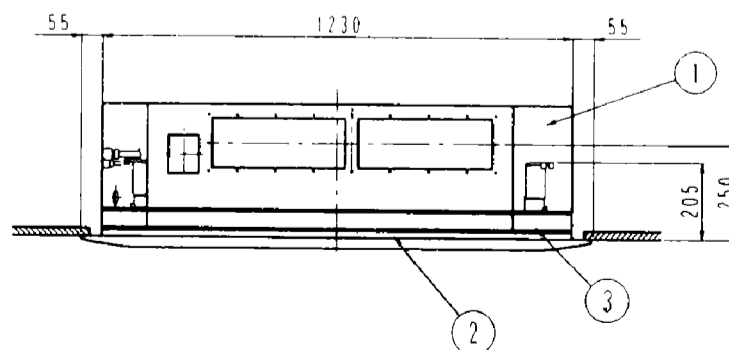
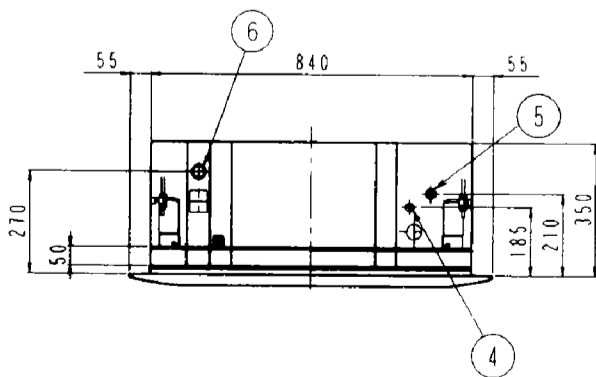
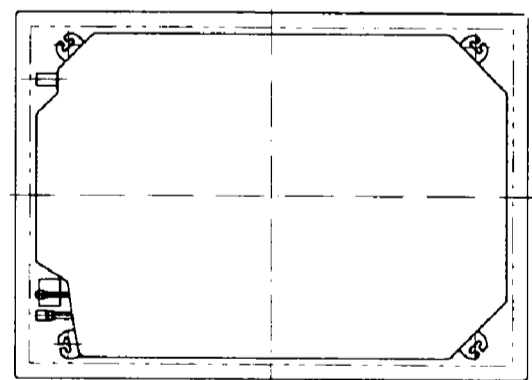


6	Drain pipe connection	
5	Gas pipe connection	
4	Liquid pipe connection	
3	Lifter style suction grille	
2	Decoration panel	
1	Main body of indoor unit	
Number	Name	Description

# KDVJ55F160

● FH(Y)C100F~125F

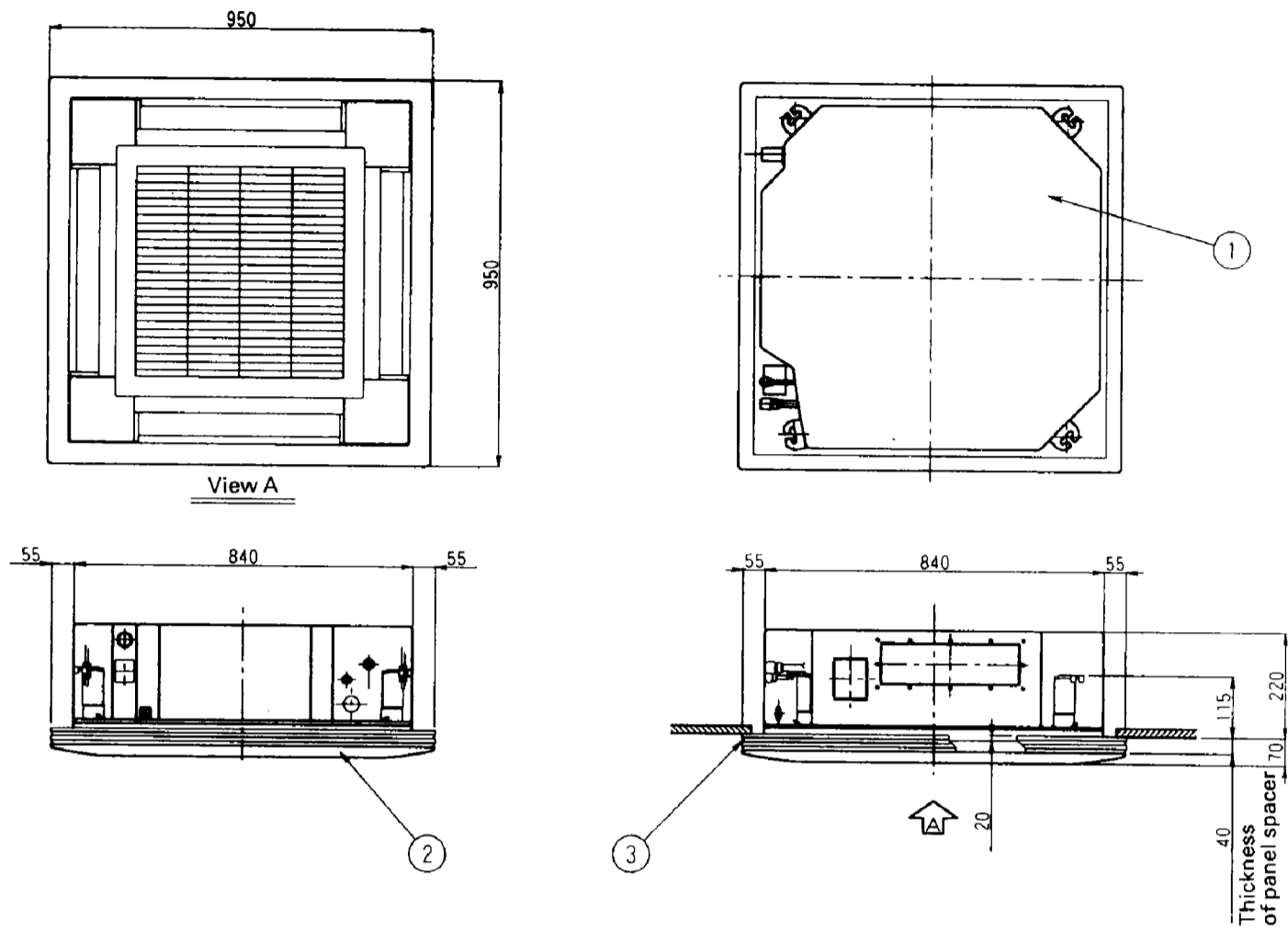
Note: When other optional kit is installed, refer to the installation drawing of its optional kit.



6	Drain pipe connection	
5	Gas pipe connection	
4	Liquid pipe connection	
3	Lifter style suction grille	
2	Decoration panel	
1	Main body of indoor unit	
Number	Name	Description

# Panel spacer KDBJ55F80W

● FH(Y)C35F~71F

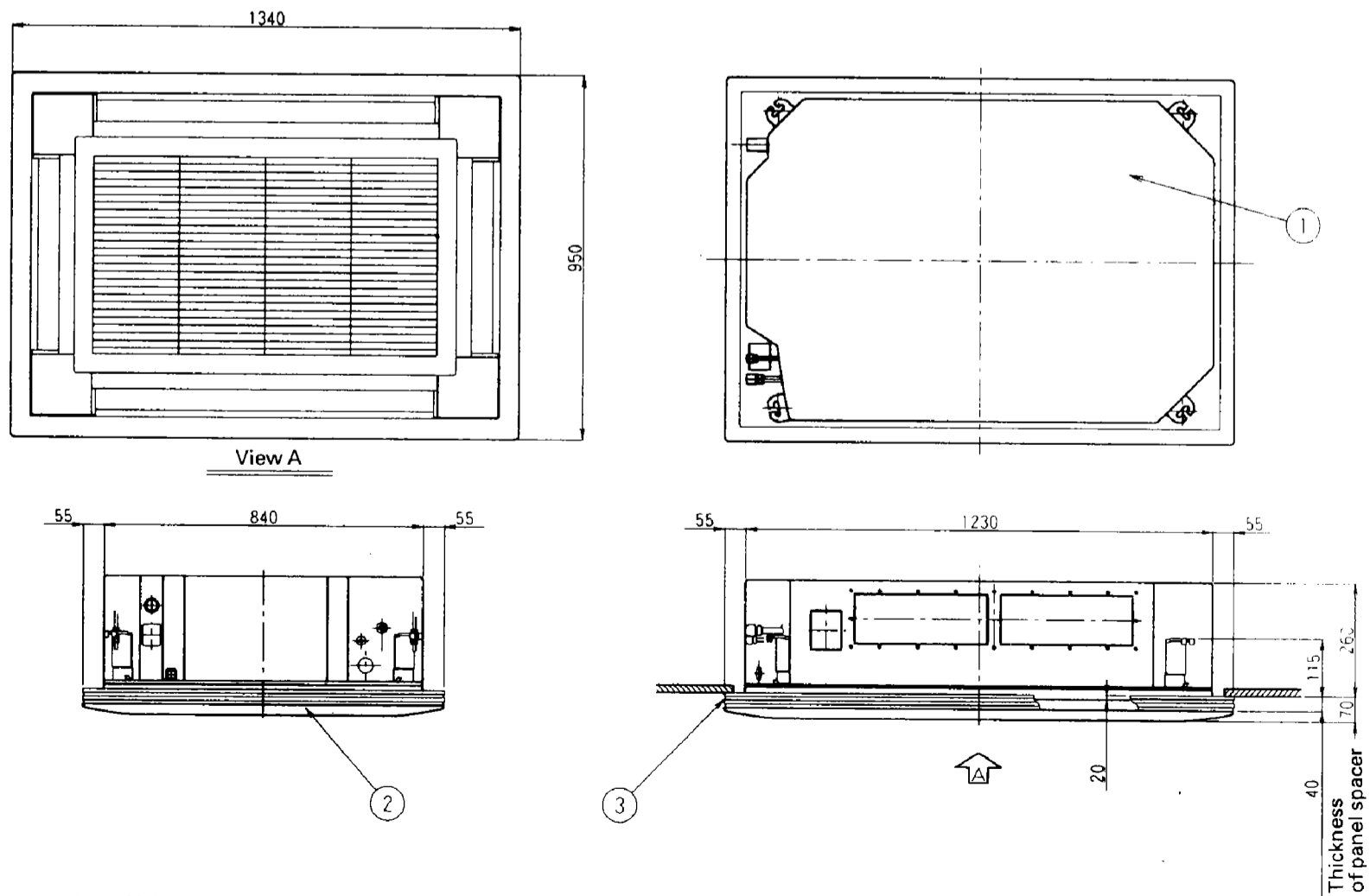


Note: When other optional kit is installed, refer to the installation drawing of its optional kit.

Number	Name	Description
3	Panel spacer	
2	Decoration panel	
1	Indoor unit	

# KDBJ55F160W

● FH(Y)C100F~125F



Note: When other optional kit is installed, refer to the installation drawing of its optional kit.

Number	Name	Description
3	Panel spacer	
2	Decoration panel	
1	Indoor unit	

## 9 Ceiling mounted cassette corner type [FH(Y)K]

### 9.1 Decoration panel – BYK45FJW1-71FJW1

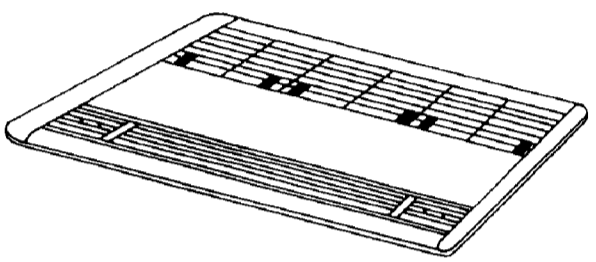
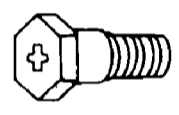

#### BEFORE INSTALLATION

##### PRECAUTIONS

- Refer also to the installation manual attached to the indoor unit.

##### ACCESSORIES

- The box contains this manual and the parts listed below.

Item	Description	Quantity	
		BYK45FJ	BYK71FJ
Decoration panel		1 set	1 set
Panel fixing screw	 M5 X 35	5 pcs.	5 pcs.
Washer		5 pcs.	5 pcs.

##### NOTE TO INSTALLER

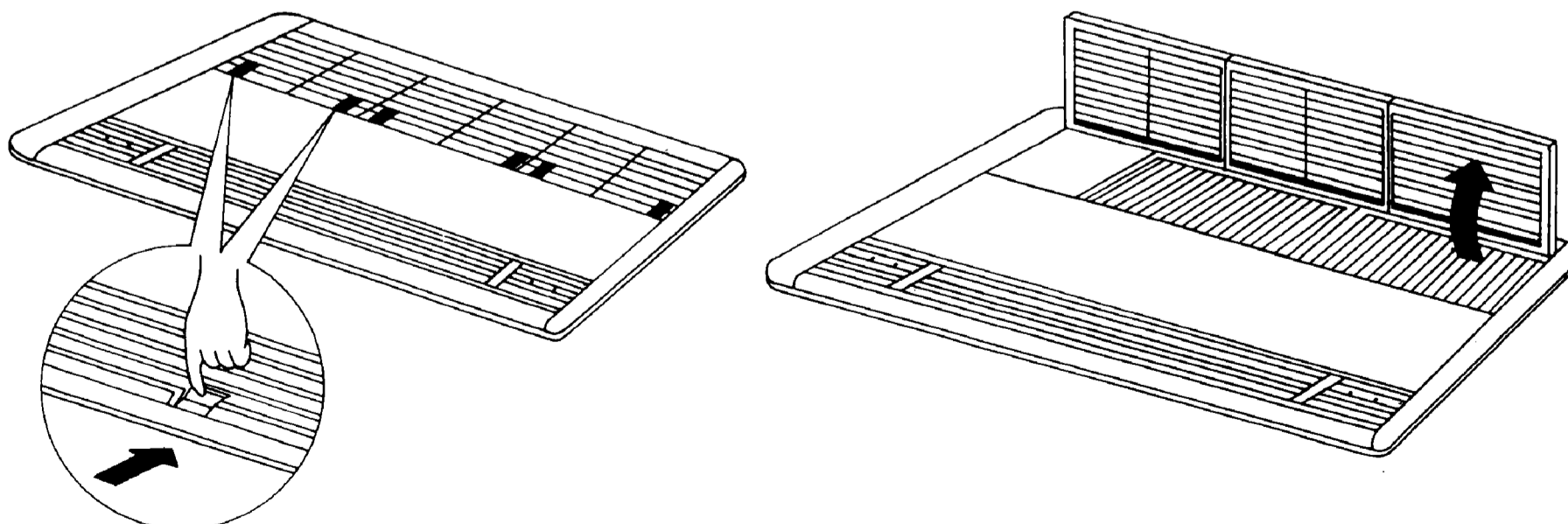
Be sure to instruct the customer how to properly operate the system showing him/her the attached operation manual.

#### PREPARATION OF DECORATION PANEL

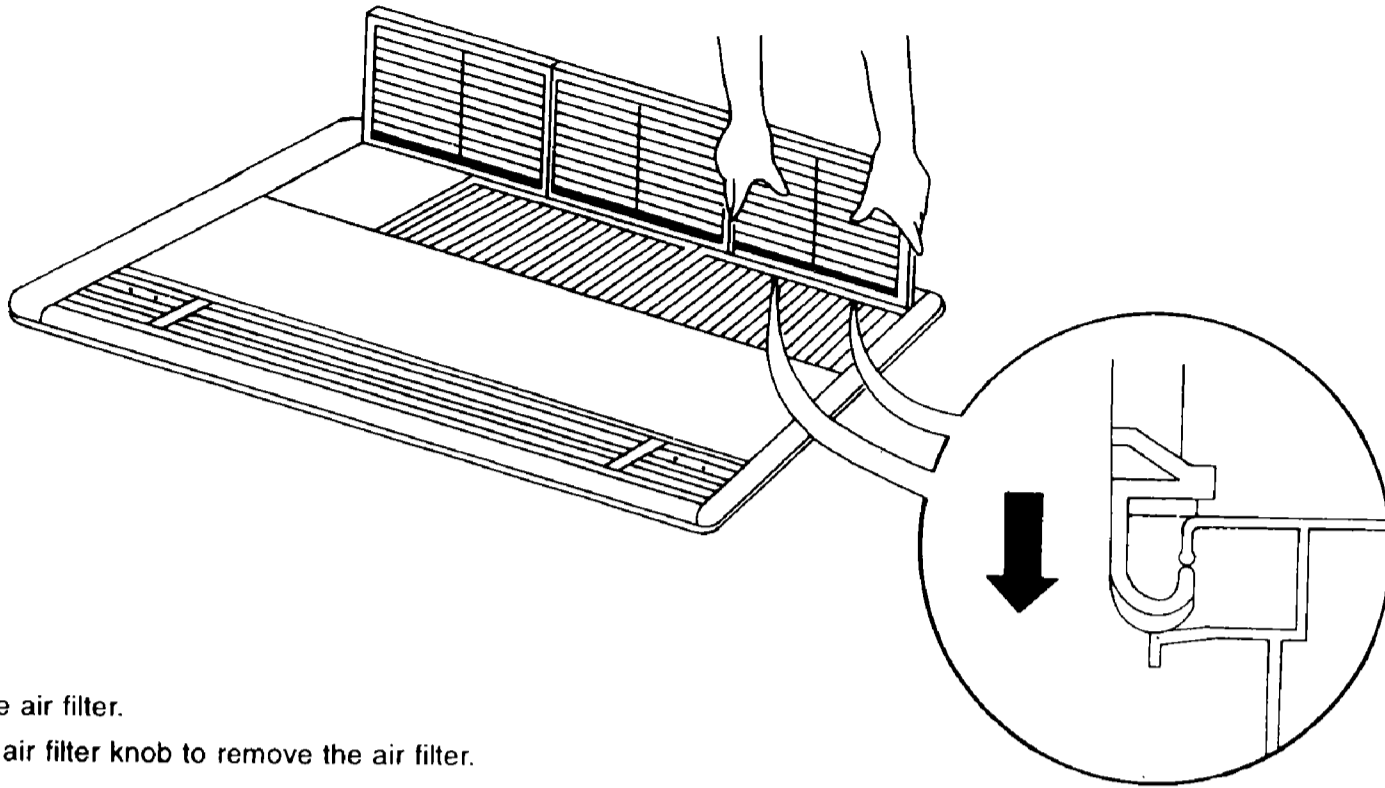
- Handle the decoration panel with care.  
< Never lean the panel against a wall, etc. nor leave it on a projecting object. (For prevention of dents and damages to the panel surface)  
Never grab the discharge grille during the installation work. (For prevention of damage to the discharge grille) >

(1) Remove the suction grille from the decoration panel. (See figure below.)

- ① Slide the suction grille lever and lift it up to one side.

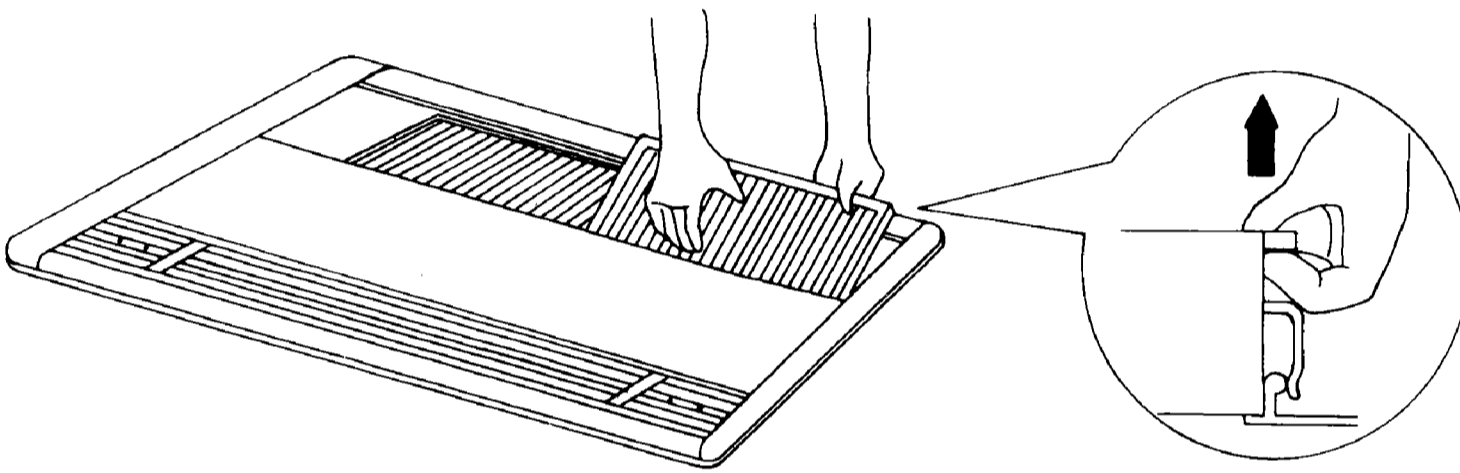


② Unhook the suction grille off from the decoration panel.



(2) Remove the air filter.

Pull up the air filter knob to remove the air filter.

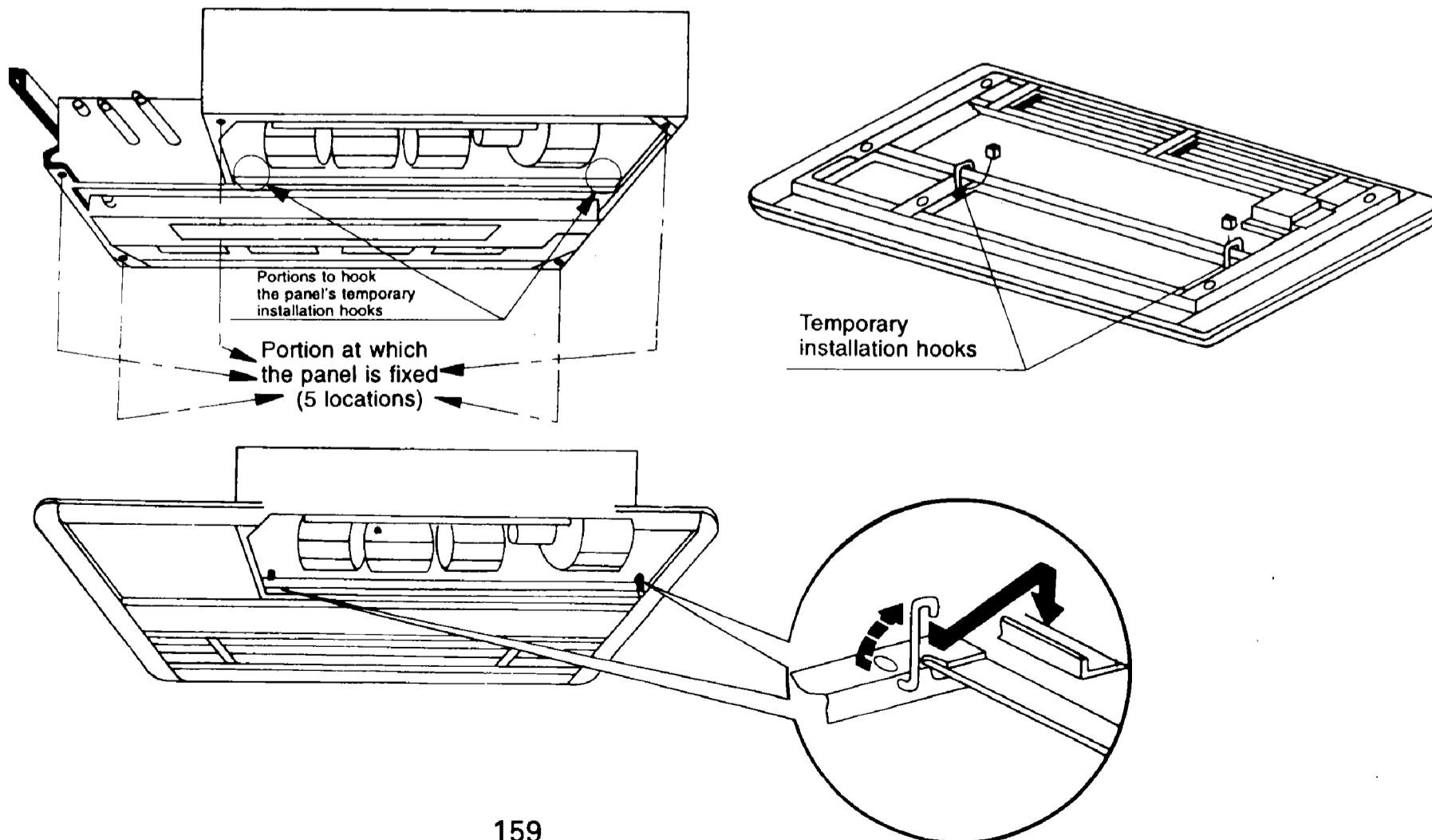


## INSTALLATION OF THE DECORATION PANEL TO THE INDOOR UNIT BODY

<< Refer to the installation manual attached to the indoor unit for the installation of the indoor unit. >>

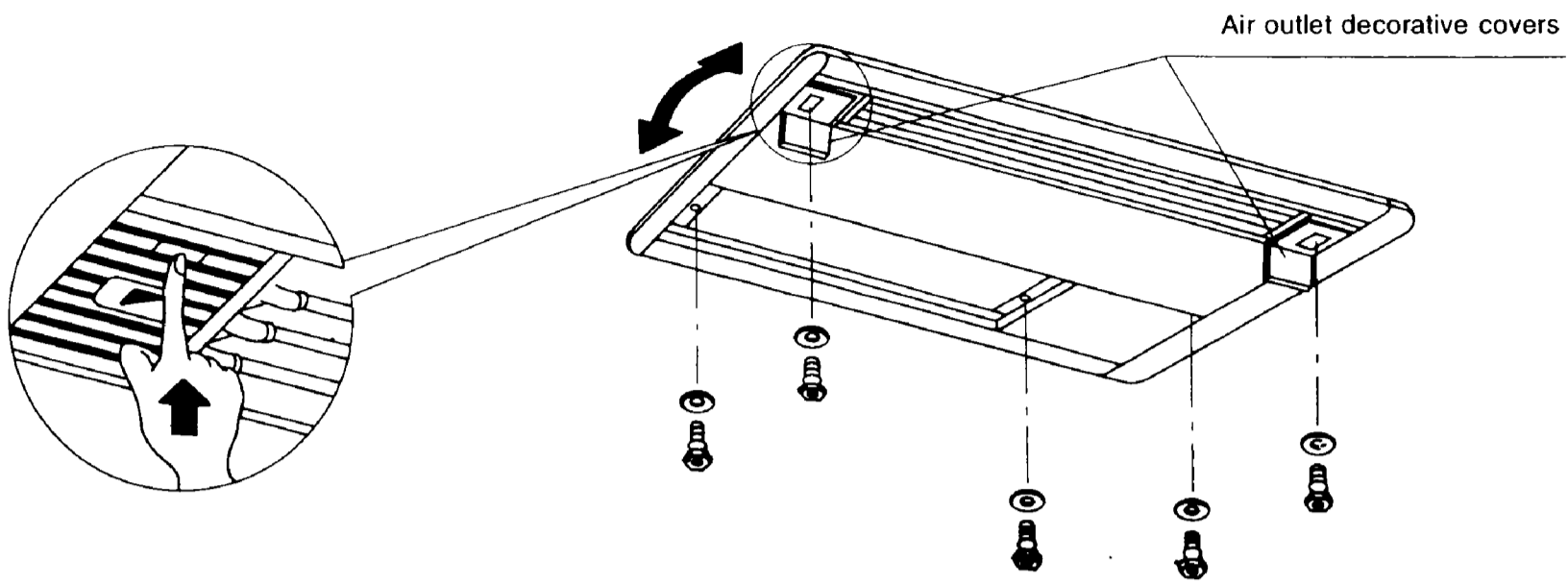
### 1. Installing the panel

(1) Install the decoration panel to the indoor unit body temporarily.



(2) Tighten the panel fixing screws temporarily.

① Open the air outlet decorative covers.



② Put the panel fixing screws (5 pcs.) through the washers and tighten the screws temporarily.

③ Move the panel as indicated by the arrow in the above figure for adjustment so as to make no gap between the panel and the ceiling.

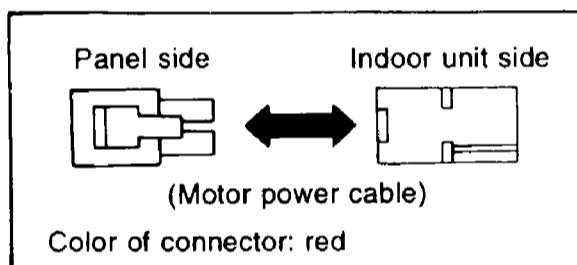
## 2. Wiring between the indoor unit and the panel

• With the decoration panel temporarily installed to the indoor unit, wire between the indoor unit and the decoration panel.

(See figure below.)

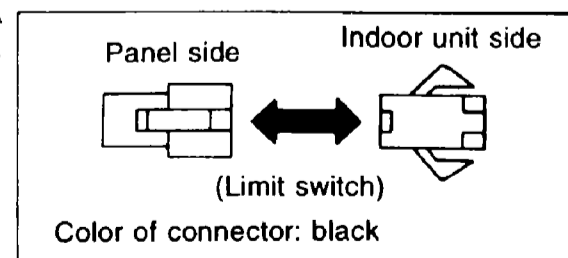
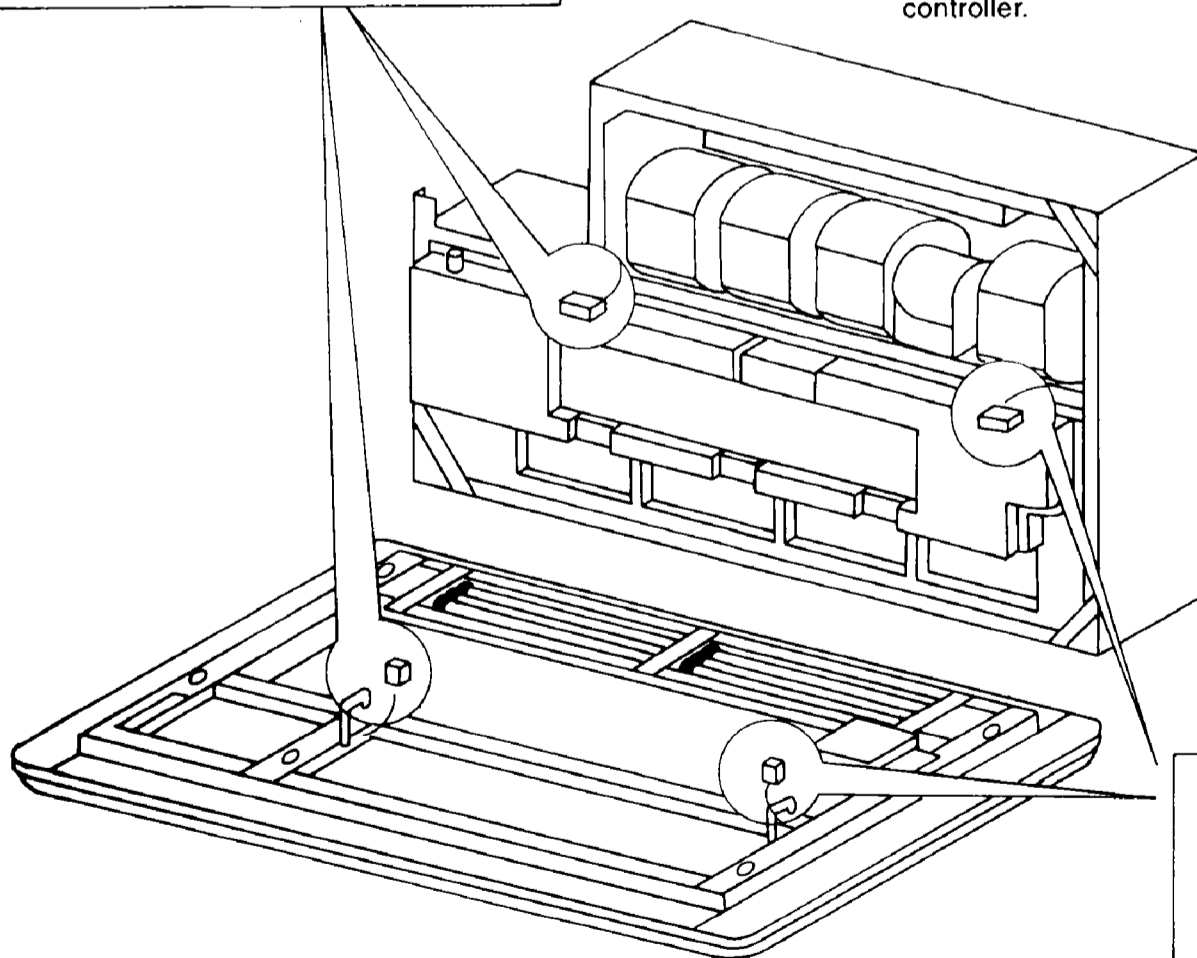
(1) Connect the connectors for swing motor and the limit switch on the decoration panel to those on the indoor unit body respectively.

(2) Check that the connectors are of the same color.



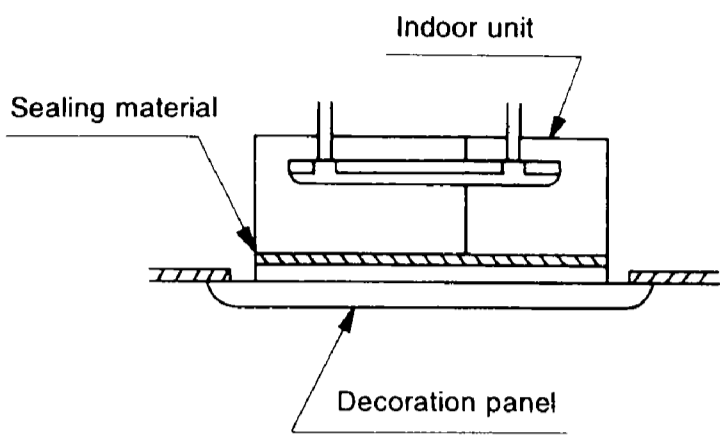
### Note:

No connection of connectors or connection of connectors of different colors causes the unit to stop operating with the Operation lamp on the remote control blinking and the trouble code display "A7" on the remote controller.



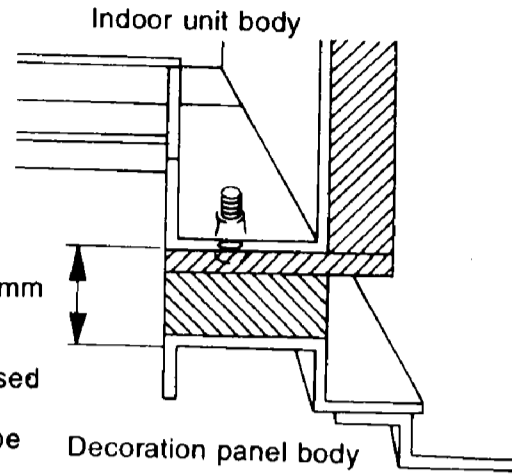
**3. Fixing the decoration panel**

(1) In order to prevent air leakage, a sealing material is provided at the spot where the indoor unit body is joined with the decoration panel. Fix the decoration panel in the following method. (Shoulder bolts are used as the fixing screws. Tighten the bolts until their shoulders.)



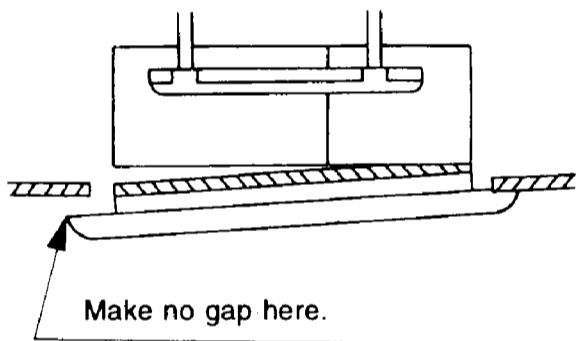
Standard tightening length: 20mm

Shoulder bolts are used to protect the indoor unit. The bolts can be tightened to the allowance of up to 15mm.



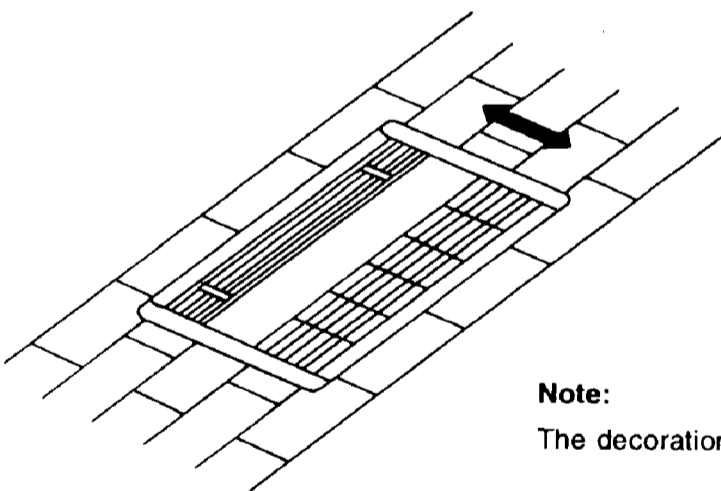
(2) When tightening the bolts, be sure to make no gap between the panel and the ceiling and set the panel in parallel to the ceiling and the ceiling joint.

( Improper installation of the panel to the cassette body causes air leakage. )



**Note:**

In case there remains a gap between the panel and the ceiling when the fixing bolts have been tightened fully to their shoulders, adjust the height of the indoor unit.

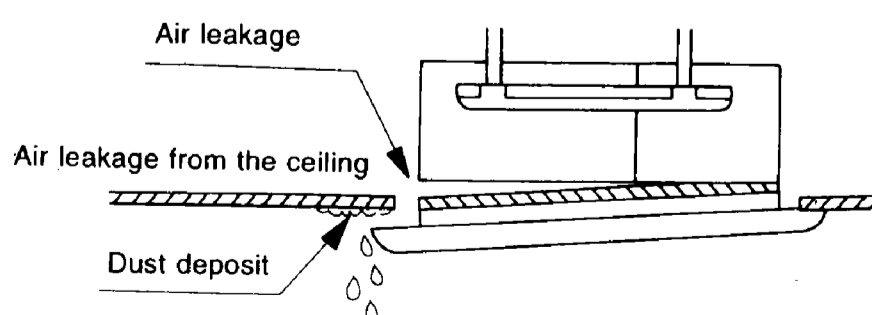
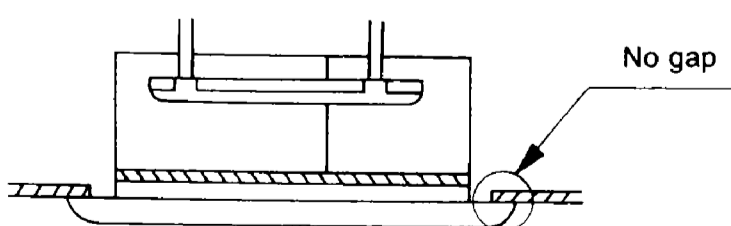


**Note:**

The decoration panel can be adjusted back and forth to 10 mm, respectively.

(3) Finally, make sure that the decoration panel is securely fixed to the indoor unit.

( Improper installation (tightening) causes the troubles as shown below; be sure to double-check the completion of the installation work. )



Dew buildup and dew dripping



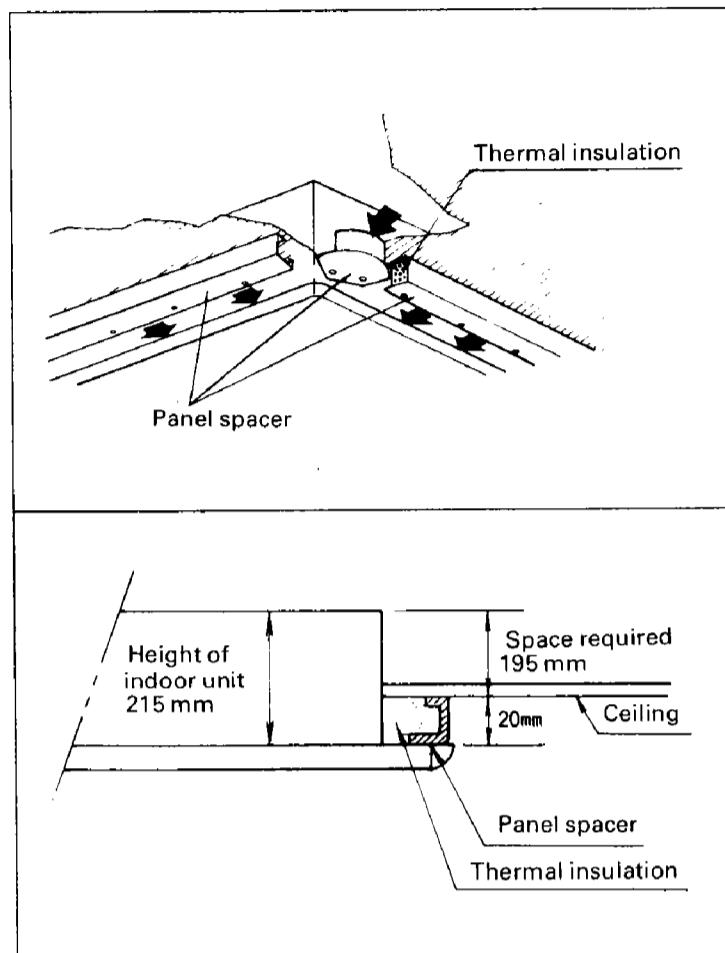
## 9.2 Panel spacer – KPBJ52F56W-80W

If the space above the ceiling is not available for more than 220mm, use the panel spacer, which enables to install the unit in 200mm space.

### ● Specifications

Kit name	KPBJ52F56W	KPBJ52F80W
Item	White	
Dimensions (mm)	Height	20
	Width	1,240
	Depth	800
Materials	Outer frame : plastic molding Thermal insulation : Foam polyethylene	
Contents	Panel spacer(1)(2)(3) Thermal insulation (1)(2), Screws	
Applicable decoration panel	BYK45FJW1	BYK71FJW1
Applicable model	For indoor unit 35F~45F	For indoor unit 60F~71F

### ● Installation



### ① Combination with the decoration panel

Be sure to check the model number in the table below before installation.

Space required in the ceiling	Kit name	Color	Applied decoration panel
20 cm	KPBJ52F56W	White	BYK45FJW1
	KPBJ52F80W	White	BYK71FJW1

### ② Contents of kit

Prior to installation check whether you have the complete kit of parts as shown below including the installation manual.

Name	Panel spacer (1)	Panel spacer (2)	Panel spacer (3)	Thermal insulation (1)
Quantity	2 pieces	2 pieces	4 pieces	2 pieces
Shape				

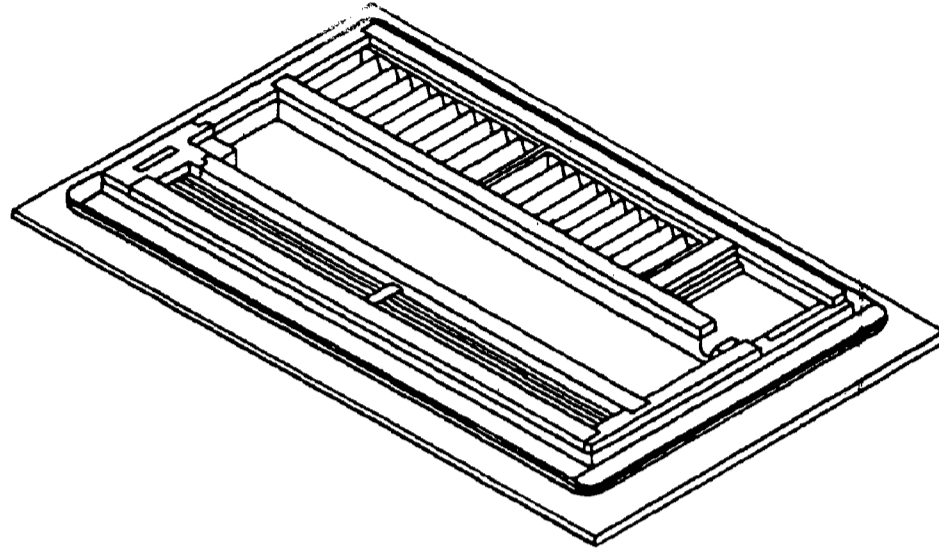
Name	Thermal insulation (2)	Screws	Installation manual
Quantity	2 pieces	18 pieces	1 piece
Shape		 M4 x 12	

### ③ Preparation of the decoration panel

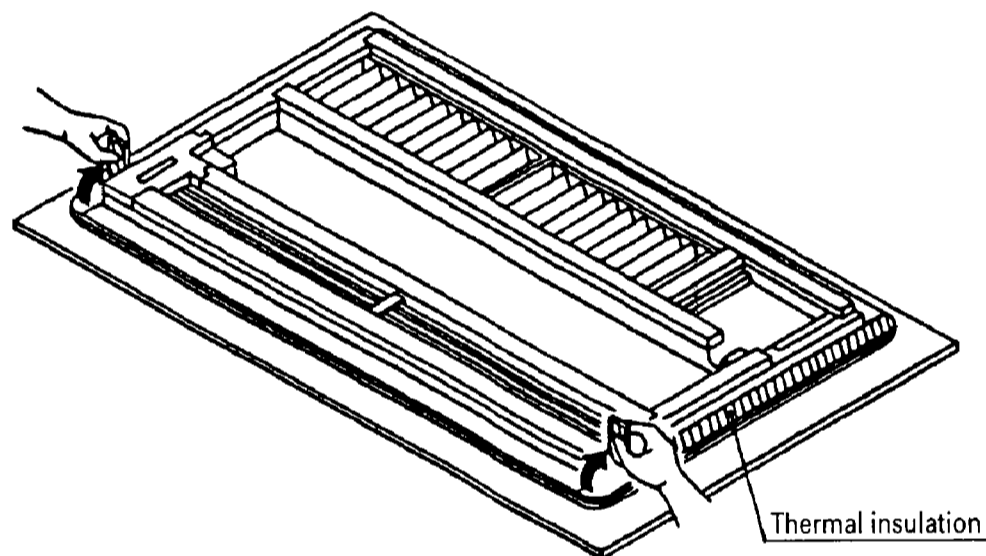
- Handle the decoration panel with care.

Never lean against the wall or leave it on a projecting object to prevent the damage on the surface of the panel. Never hold the air discharge outlet when installing to prevent the air discharge outlet from damage.

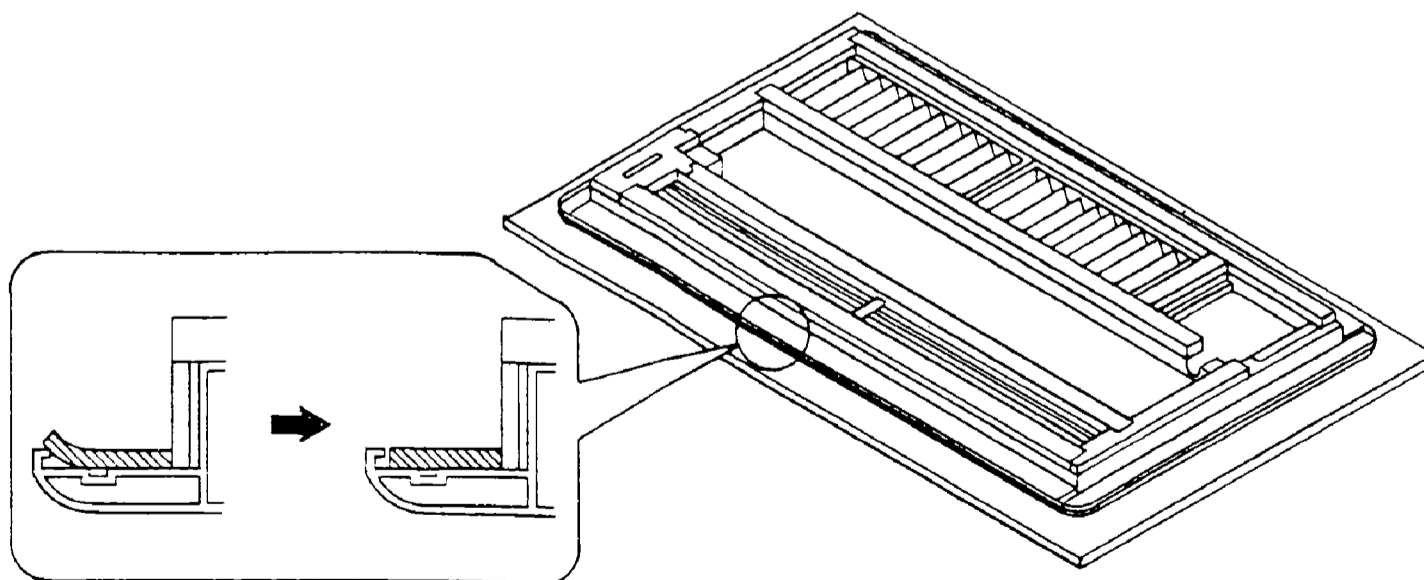
(1) Place the decoration panel face down on the corrugated cardboard or the vinyl sheet to prevent the damage on the surface.



(2) Remove the thermal insulation. (2 locations)



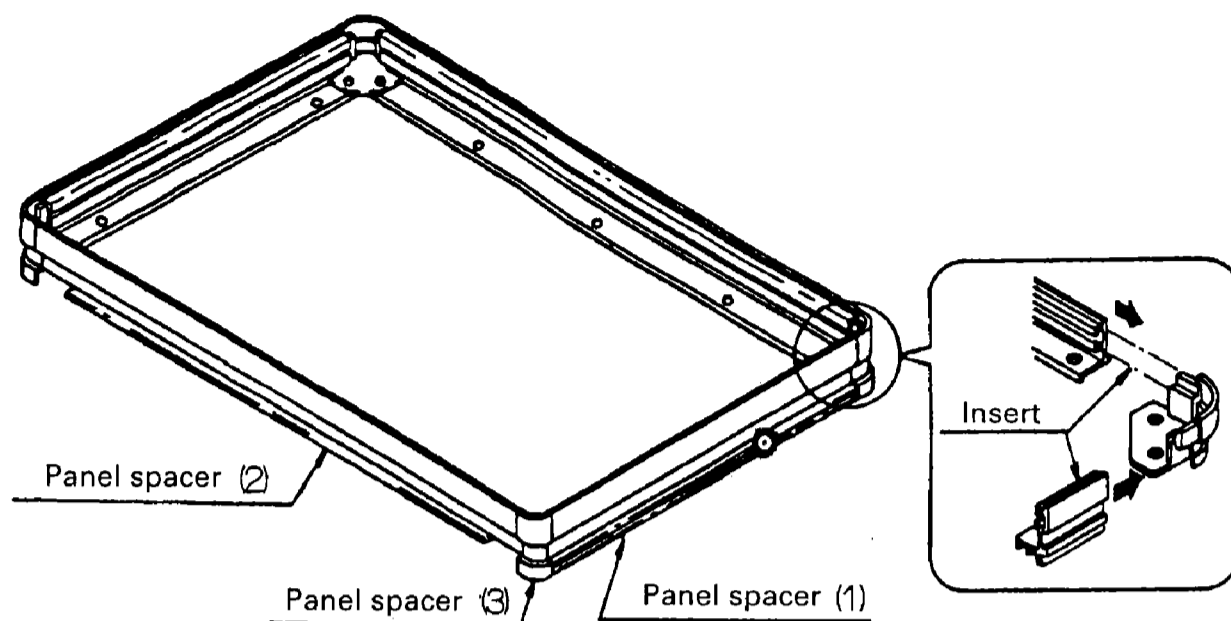
(3) Remove the glue on the thermal insulation where the panel spacer is installed. Remove also the stick-out glue on the panel frame by cutting knife etc.



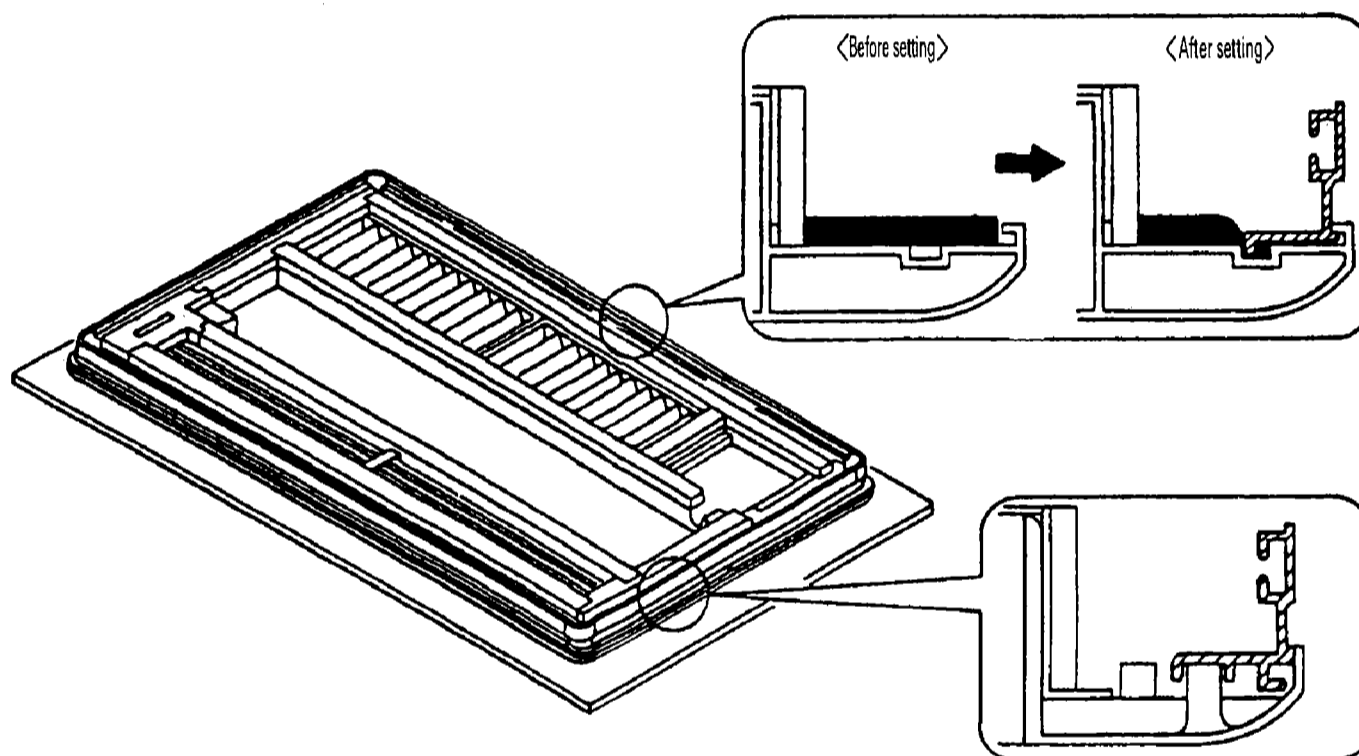


#### ④ Installation of the panel spacer

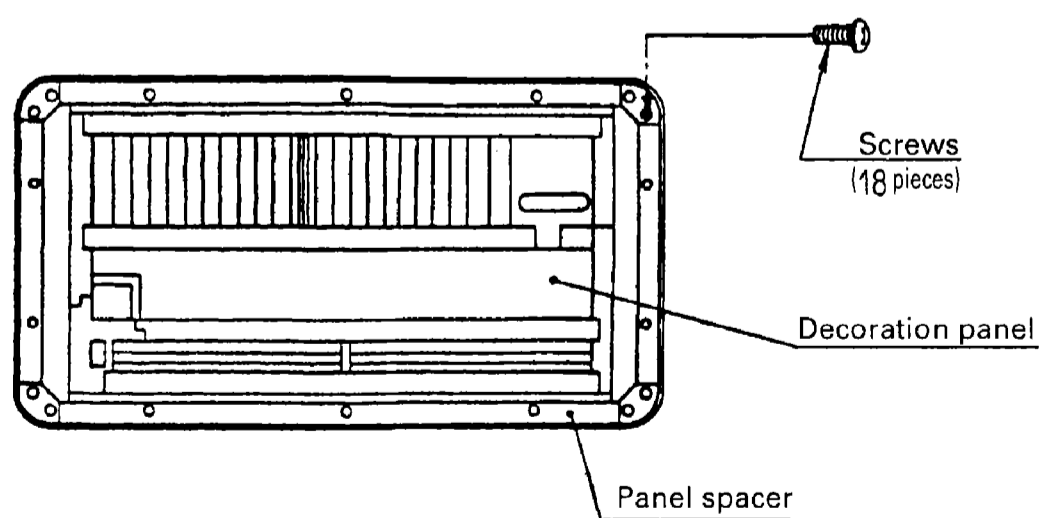
(1) Assemble the panel spacer (1), (2) and (3) temporarily.



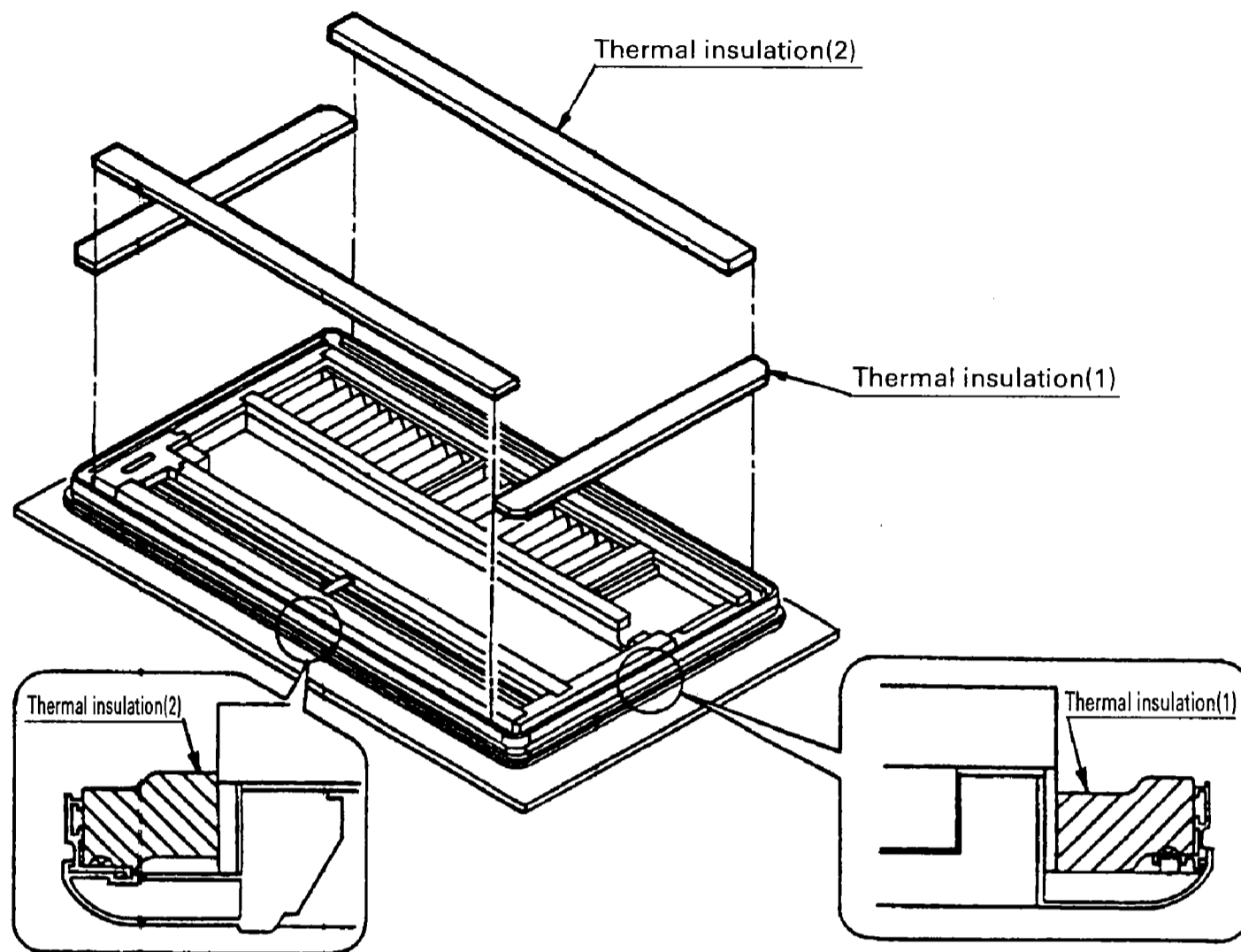
(2) Set the temporarily assembled panel spacer to the decoration panel.



(3) Fix the panel spacer to the decoration panel with screws (18 pieces).



(4) Attach the thermal insulation (1) and (2).



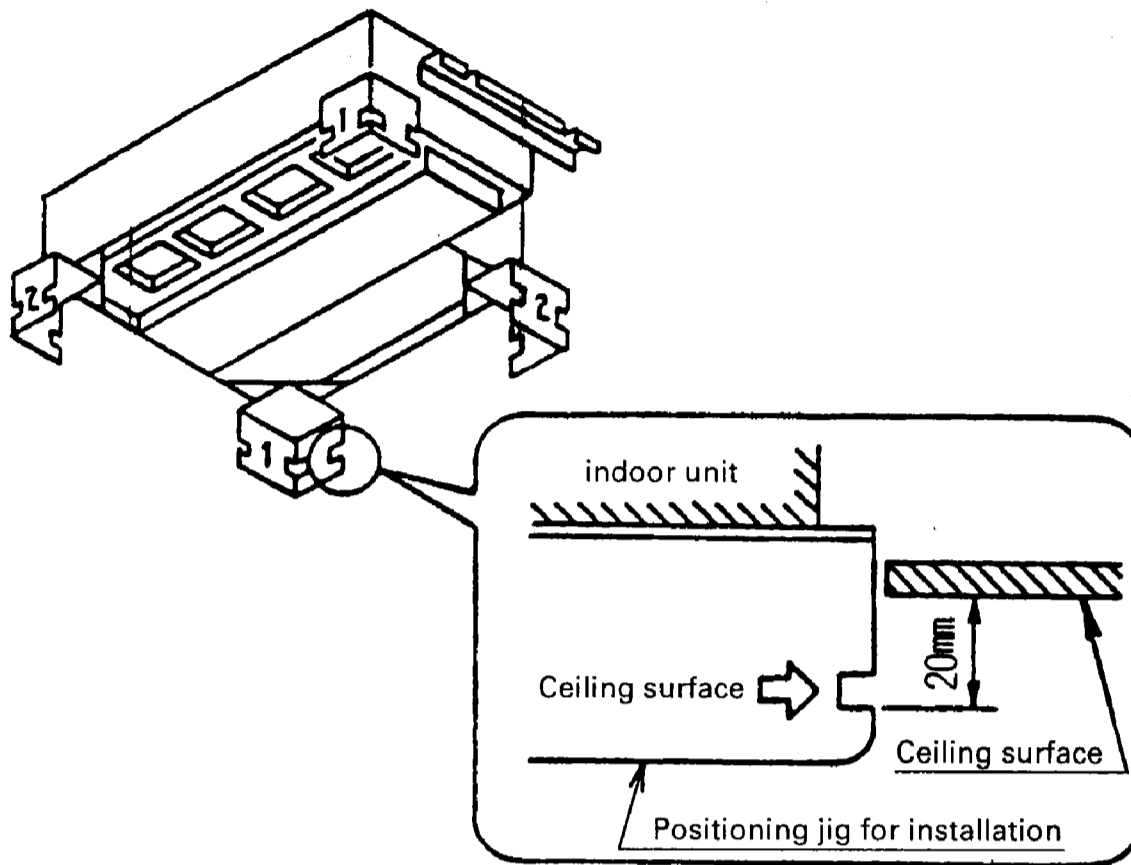
#### ⑤ Selection of the location for installation

It is required the space of 20cm above the ceiling for the installation.

Refer to the item of "Selecting installation site" of the installation manual of the indoor unit for other details.

## ⑥ Installation of the indoor unit

When you install the panel spacer, lower the indoor unit by 20cm from the standard height.



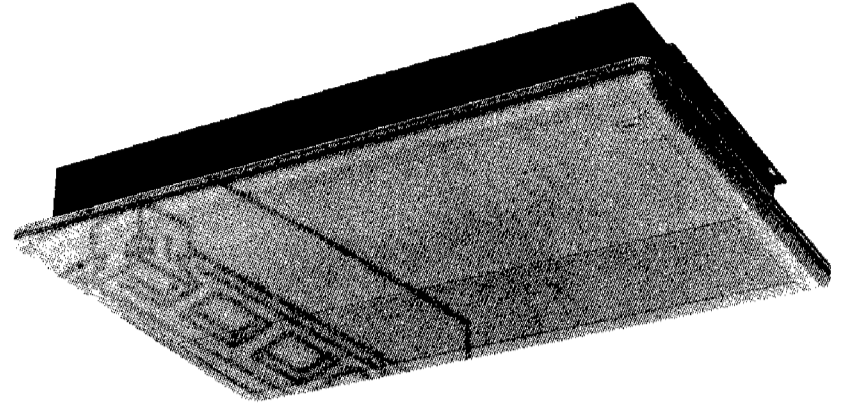
Refer to the item of "Indoor unit installation" of the installation manual of the indoor unit for other details.

## ⑦ Attachment of the decoration panel

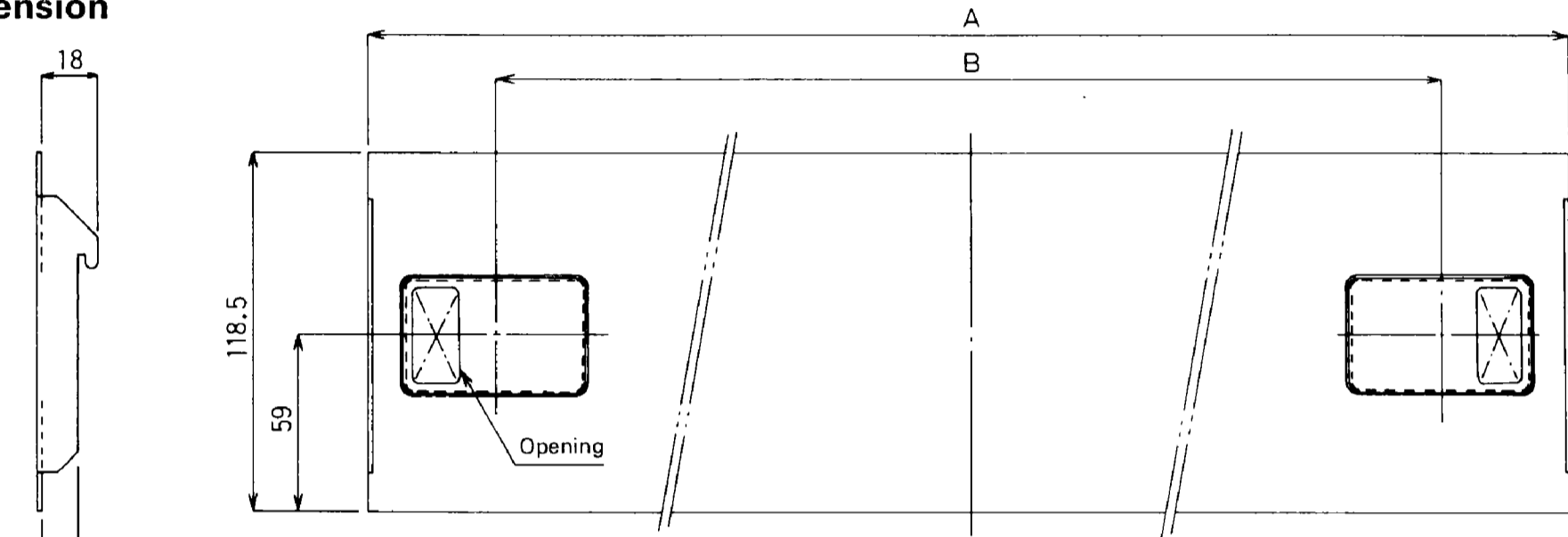
After the completion of installation of the panel spacer, attach the decoration panel to the indoor unit.

## 9.3 Air discharge blind panel-KDBJ52F56W-80W

This optional kit is to blind the bottom discharge outlet, when the unit is used with front air discharge.



### ● Dimension



Model	A	B
KDBJ52F56W	1125.5	1040
KDBJ52F80W	1325.5	1240

### ① Combination with decoration panel

This kit is used to cover the air discharge outlet of the decoration panel when the unit is installed with the front air discharge.

Name	Color	Applicable decoration
KDBJ52F56W	White	BYK45FJW1
KDBJ52F80W	White	BYK71FJW1

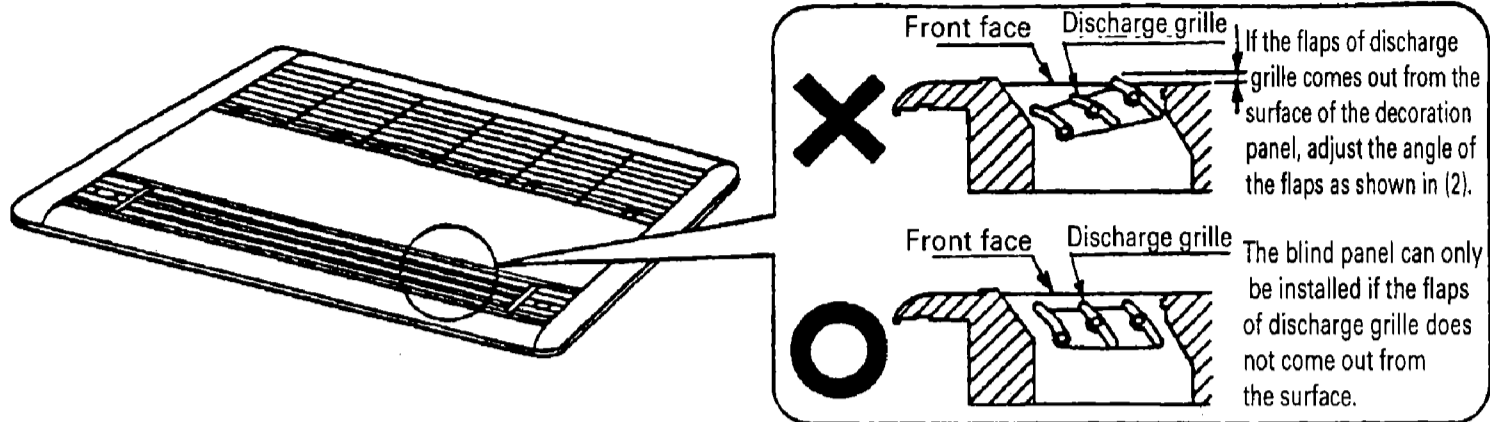
### ② Contents of kit

Prior to installation check whether you have the complete kit of parts as shown below including the installation manual.

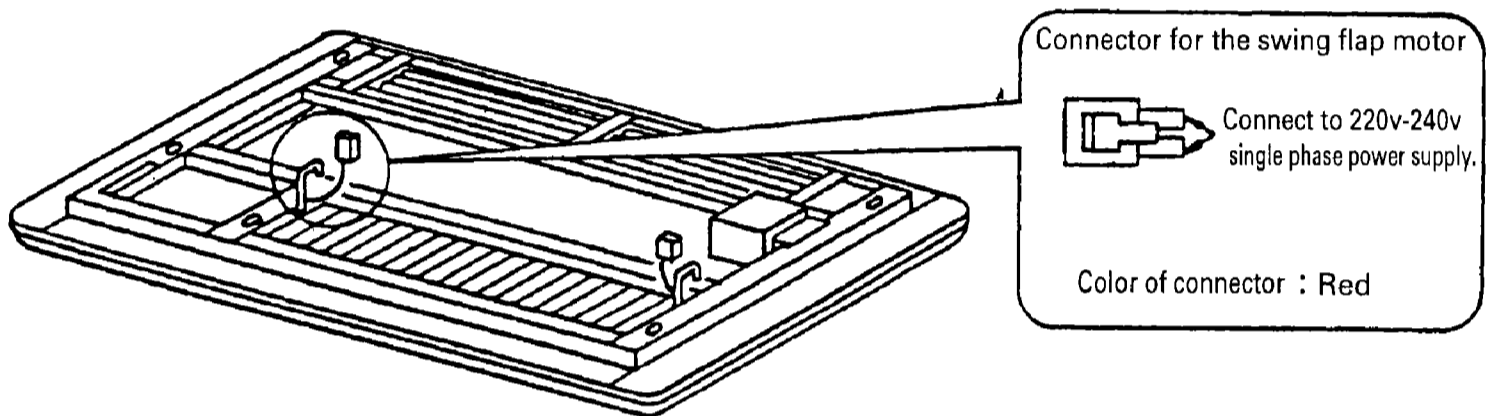
Name	Blind panel assembly	Supporting bracket	Name plate (1)	Name plate (2)
Quantity	1 piece	1 piece	1 piece	1 piece
Shape				
Name	Screws(M5×8)	Screws(M5×40)	Installation manual	Set of caution stickers
Quantity	2 pieces	2 pieces	1 piece	1 piece
Shape	 M5×8	 M5×40		

### ③ Examination of the decoration panel before removing

(1) Check the angle of the flaps of discharge grille.

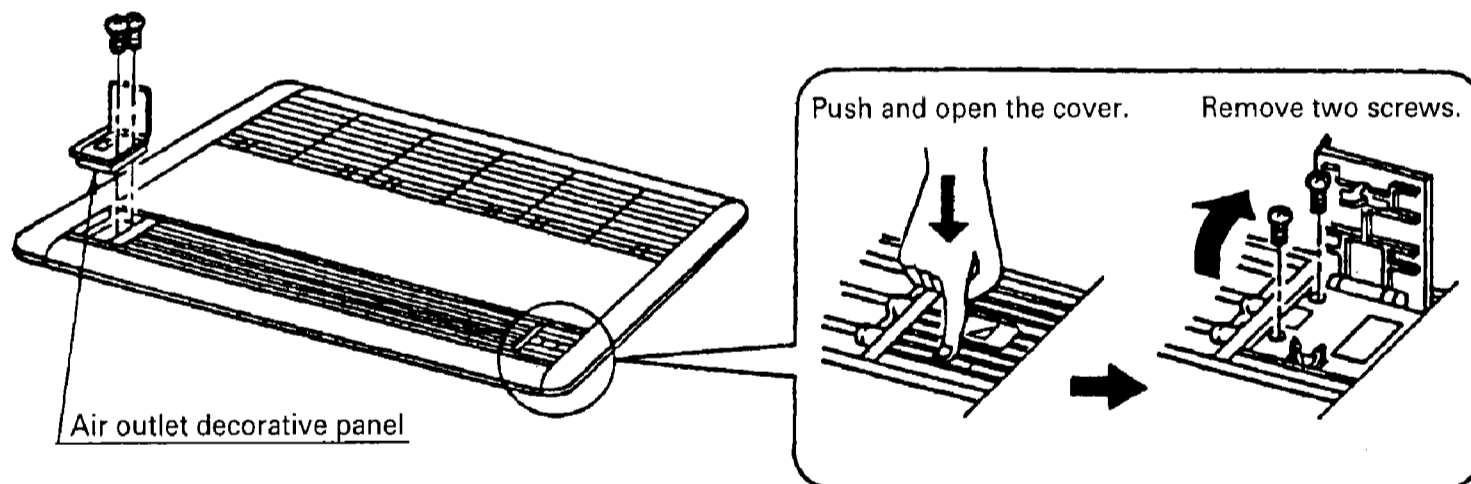


(2) If it is required to adjust the angle of the flaps, supply the electrical power(220V-240V single phase) to the air swing motor connector and adjust the position of the flaps.

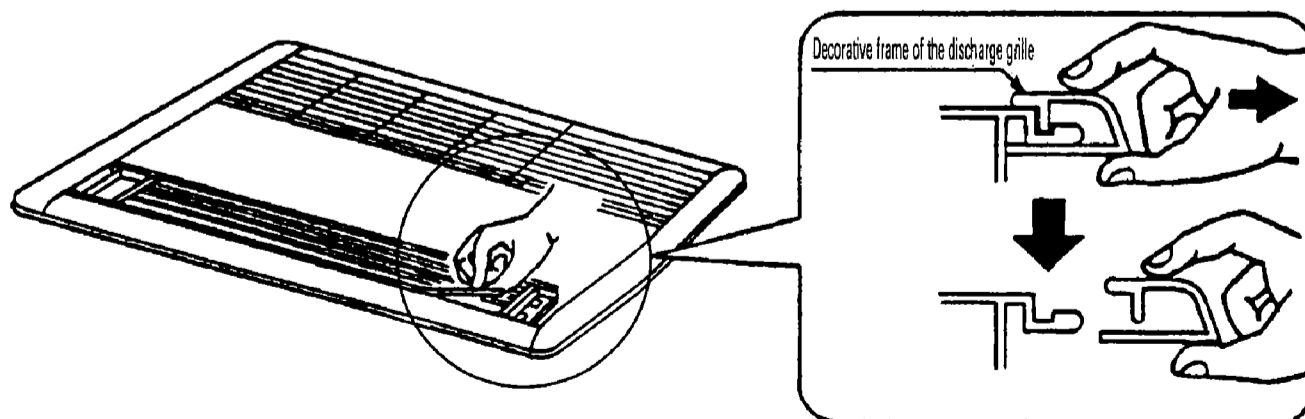


### ④ Removing the parts

(1) Remove the air outlet decorative covers.

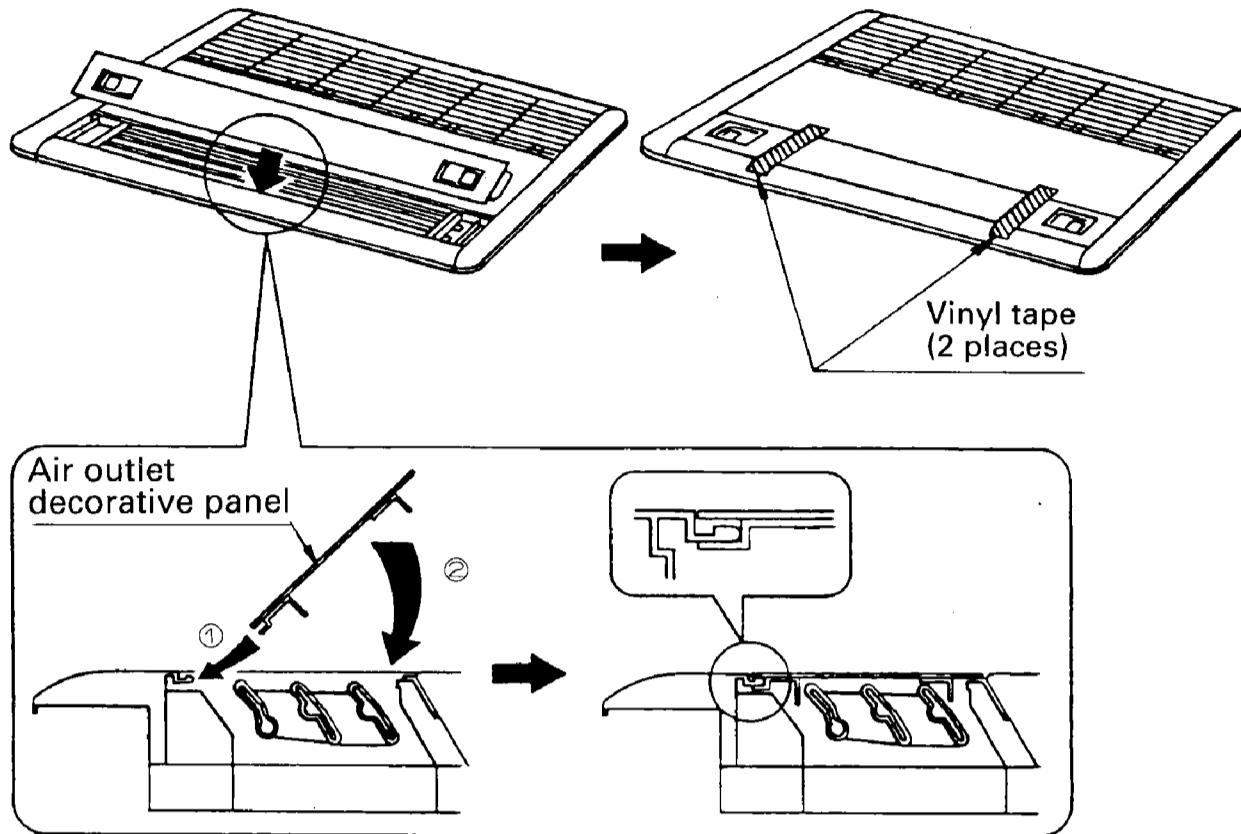


(2) Remove the decorative frame of the air discharge grille.

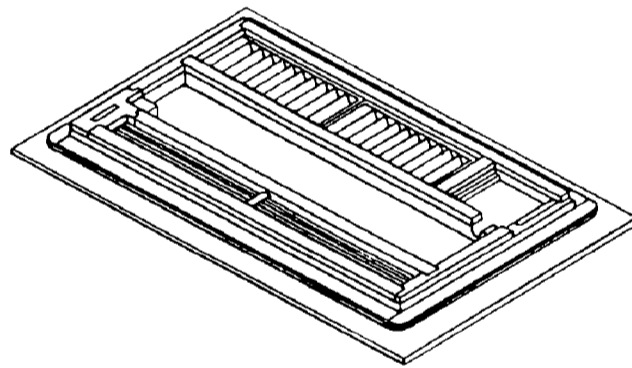


## ⑤ Installation of the air discharge blind panel

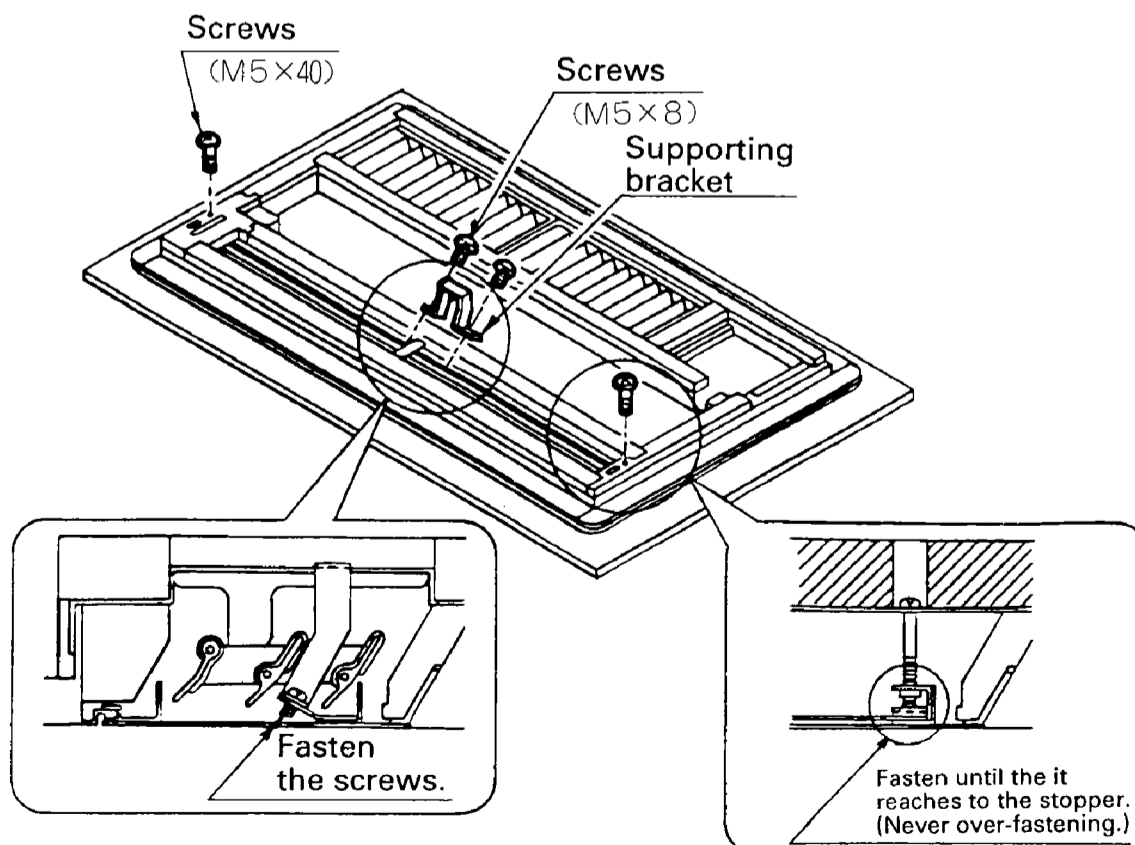
(1) Attach the air discharge blind panel and put the vinyl tape to hold panel temporarily.



(2) Place the decorative panel face down on the corrugated cardboard or vinyl sheet to protect the surface of the decoration panel.



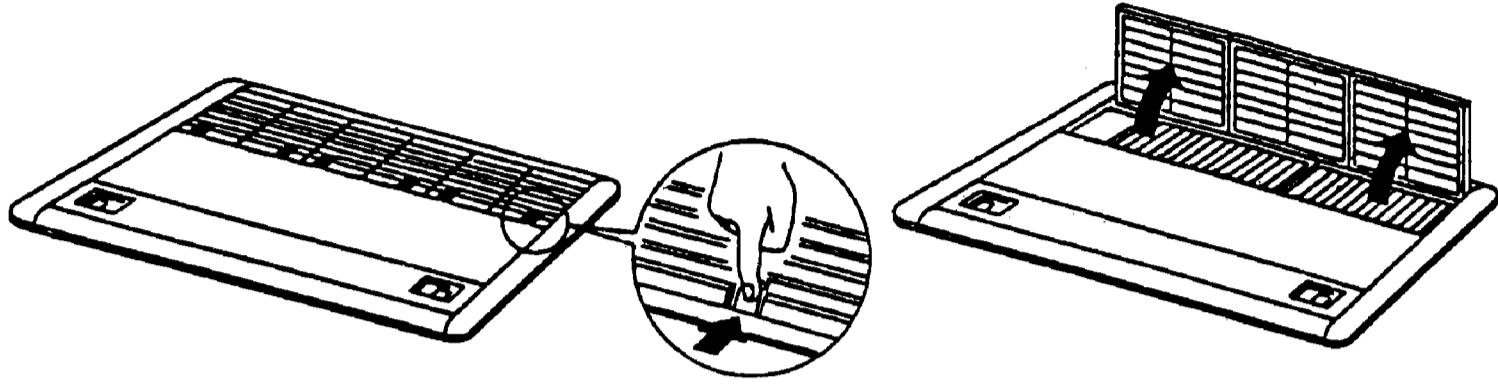
(3) Set the air discharge blind panel with the supporting bracket and fasten the screws.



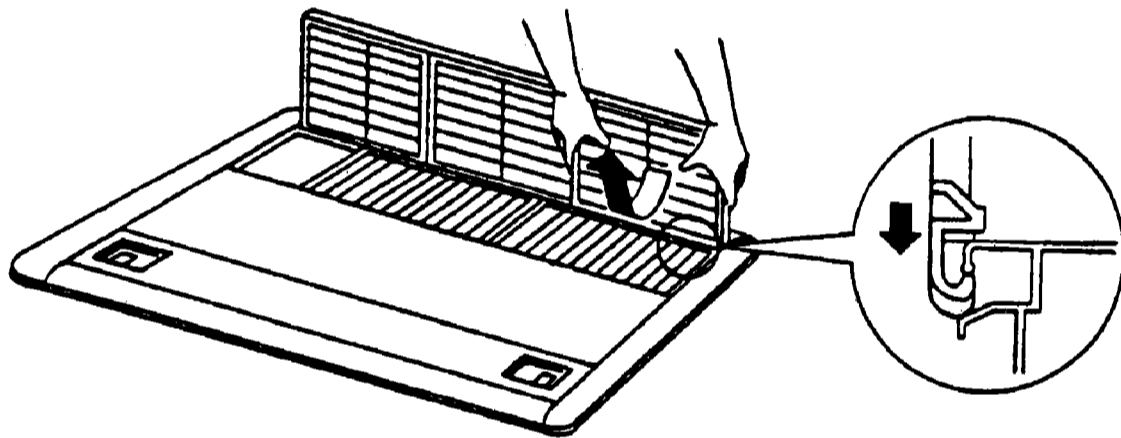
## ⑥ Preparation of the decoration panel

(1) Remove the suction grille from the decoration panel.

(1)-1 Slide the lever of the suction grille and lift it up to one side.

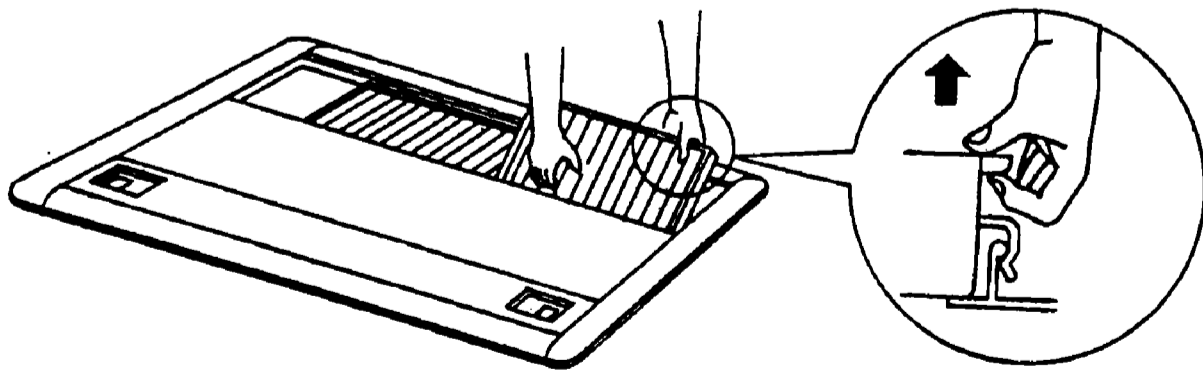


(1)-2 Unhook the suction grille off from the decoration panel.



(1)-3 Remove the air filter.

Pull up the air filter knob and remove the air filter.



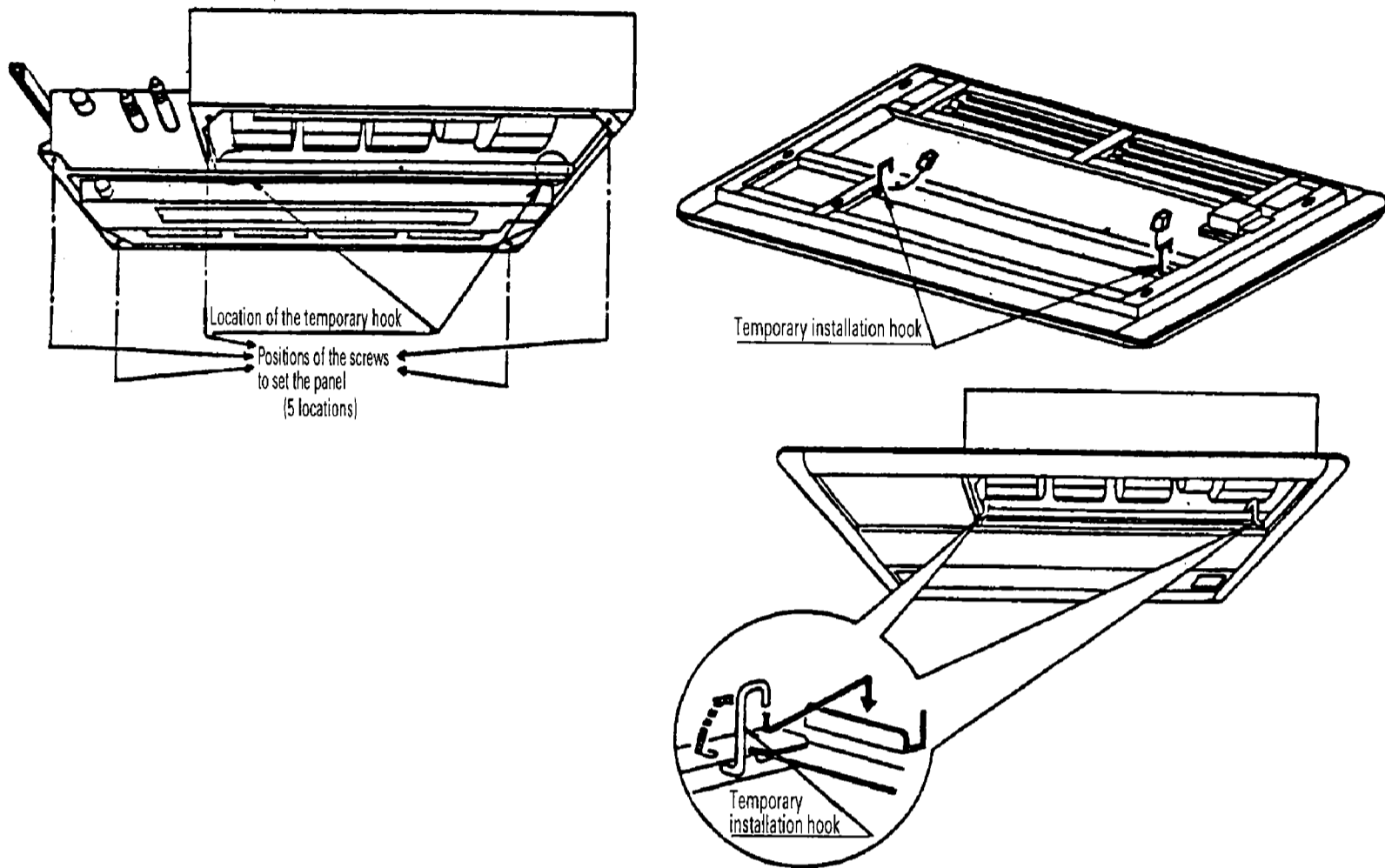
## ⑦ Installing the decoration panel to the indoor unit

Install the decoration panel after the completion of the installation of the front discharge panel.

### ① Installation of the decoration panel

Refer to the installation manual of the indoor unit for its installation.

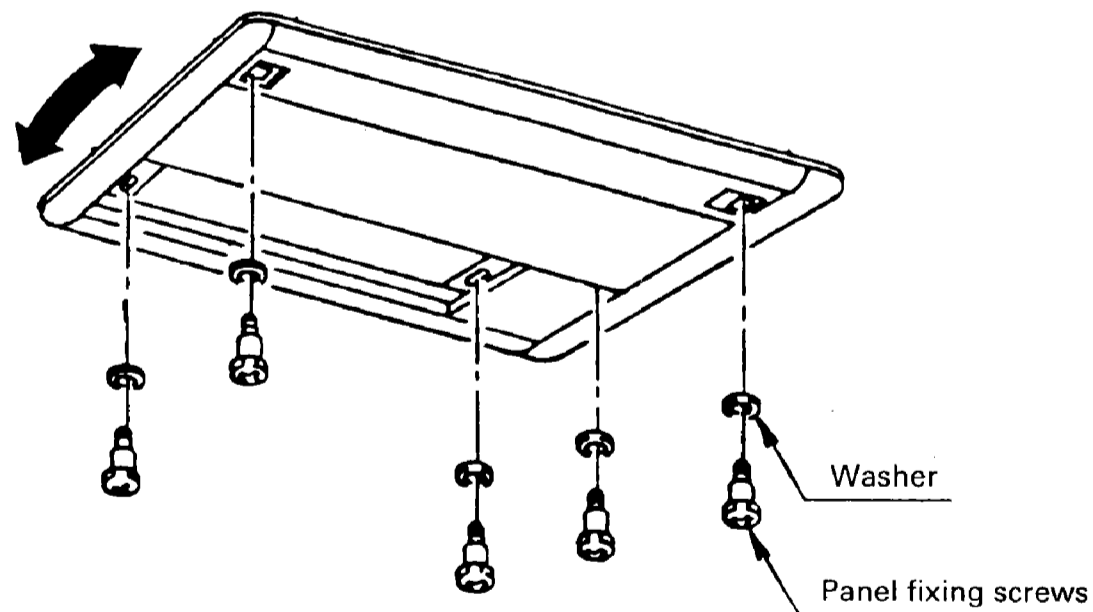
(1) Hook the decoration panel to the indoor unit temporarily.



(2) Fasten the panel fixing screws temporarily.

(2)-1 Set the washer to the screws and fasten temporarily.

(2)-2 Adjust the panel as shown below to fit with the opening of the ceiling properly.



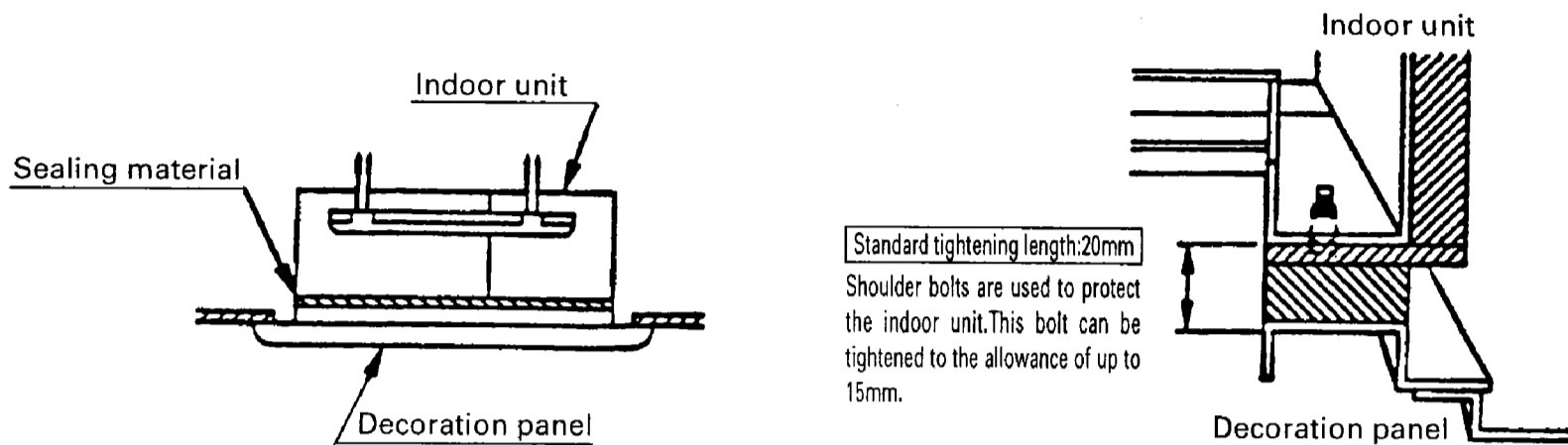


② Electrical wiring between indoor unit and the decoration panel

Never connect the connector of the swing motor and the limit switch.

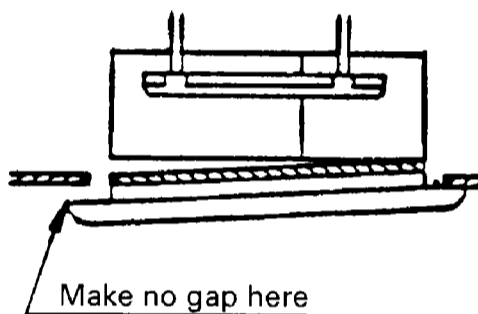
③ Fixing of the decoration panel

(1) The sealing material is attached between indoor unit and the panel to seal the air leakage from the connecting part. Fasten the screws tightly according to the following drawing. (The shoulder bolts are used as fixing screw. Tighten the bolts until their shoulders.)



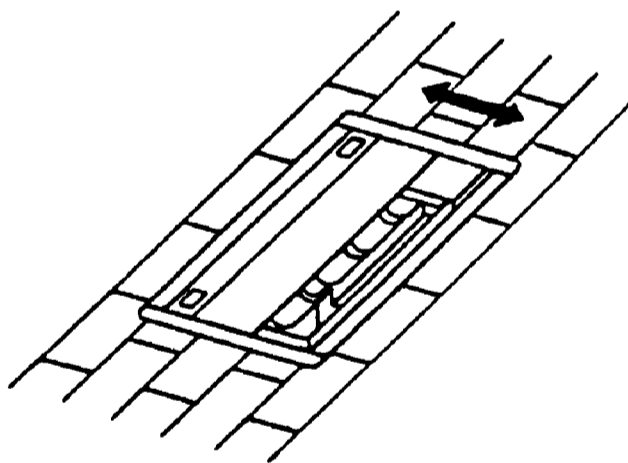
(2) When tightening the bolts, be sure to make no gap between the panel and the ceiling, and set the panel in parallel to the ceiling and the ceiling joint.

Improper installation of the panel to the indoor unit causes air leakage.



**Caution**

If there still be a gap between the panel and the indoor unit after tightening the bolts up to the shoulder, adjust the height of the indoor unit.

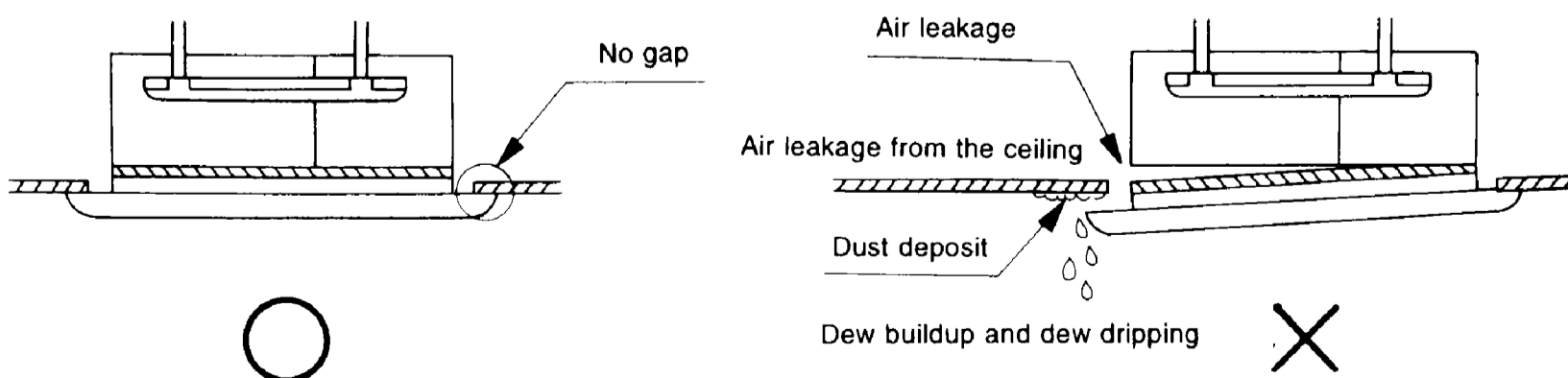


**Caution**

The decoration panel can be adjusted back and forth to 10mm respectively.

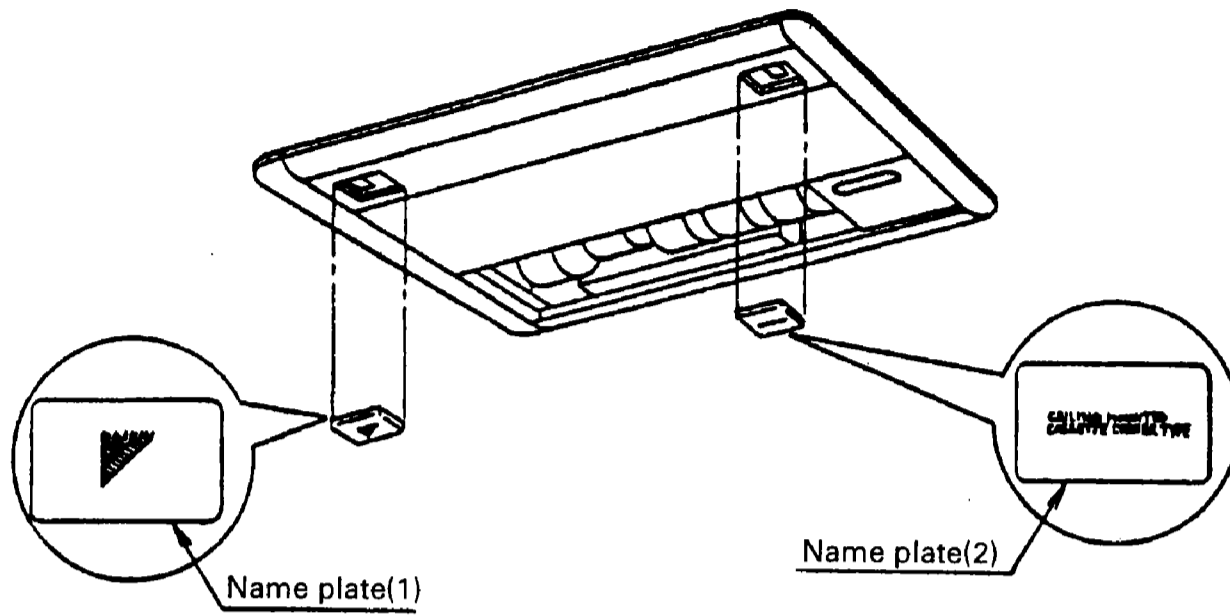
(3) Make sure whether the decoration panel is securely fixed to the indoor unit.

Improper installation (loose tightening) causes the trouble as shown below. Be sure whether the installation is completed properly again.

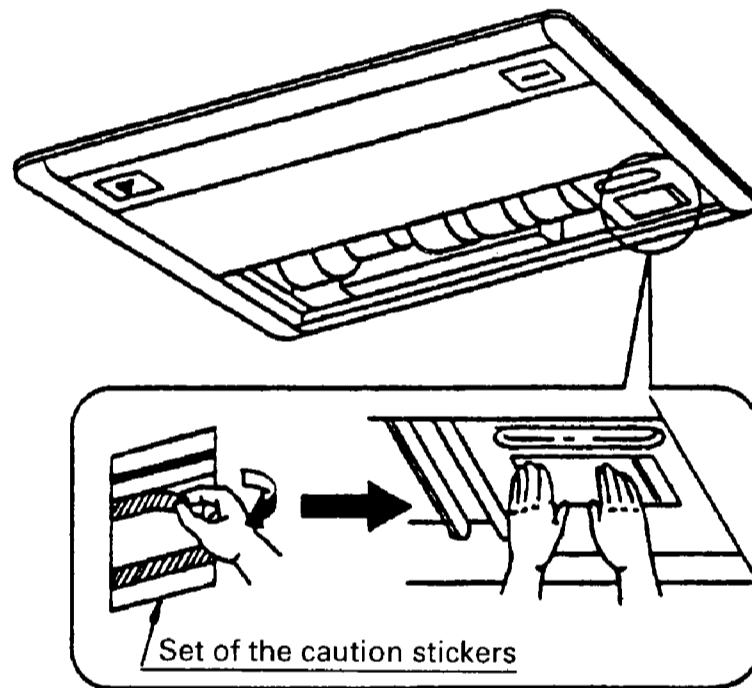


## ⑧ Attaching the set of name plate

(1) Attach the name plates as follows.



(2) Attach the set of caution stickers.



## ⑨ Installation of the suction grille and air filter

Refer to the item ⑦ "Preparation of decoration panel" of this manual, and install it in the reverse step.

## 9.4 Replacement long-life filter – KAFJ521F56-80

### ● Specifications

Model	Item	KAFJ521F56	KAFJ521F80
Effective life, Average efficiency		2500 hours (at duct particle concentration of 0.15mg/mm <sup>3</sup> ), 45% (by weight method)	
Filter material		Resin net (With mold resistant)	
Number required for unit		2	2
Applicable model		For indoor unit 35F~45F	For indoor unit 60F~71F

## 9.5 Discharge grille – KDGJ52F56W-80W

This optional kit is used when the unit is installed with front air discharge. The direction of air can be adjusted flexibly.

This discharge grille should be installed with the following flexible duct.

Model	Applicable model	A	B	C	D	E
KDGJ52F56W	For indoor unit 35F~45F	466	440	485	20	500
KDGJ52F80W	For indoor unit 60F~71F	666	640	685	20	700

## 9.6 Flexible duct with shutter – KFDJ52F56-80

The air volume can be adjusted by the shutter installed in the duct. It is a flexible duct, and it can be connected flexibly.

Model	Applicable model	A	B	C	D	E	F
KFDJ52F56	For indoor unit 35F~45F	260	520	466	498	530	4-φ Hole
KFDJ52F80	For indoor unit 60F~71F	460	720	666	698	730	6-φ7 Hole

## ① Combination with discharge grille

The "Discharge grille" is also required, when you install the flexible duct.

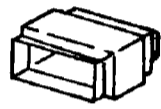
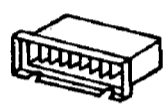
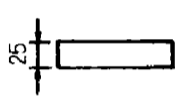
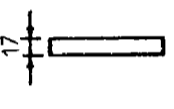



When you install the unit with "Horizontal air outlet", the air discharge blind panel of optional kit can be installed on the decoration panel, if necessary.





Flexible duct	Discharge grille	Color	Applied model
KFDJ52F56	KDGJ52F56W	White	FH(Y)K35-45F FXYK25K~40K
KFDJ52F80	KDGJ52F80W	White	FH(Y)K60-71F FXYK63K

**Note:** Be sure to use the original optional discharge grille. If you use the discharge grille in the market, you may have a problem with the distribution of the room temperature or the condensation on the grille.

## ② Contents of kit

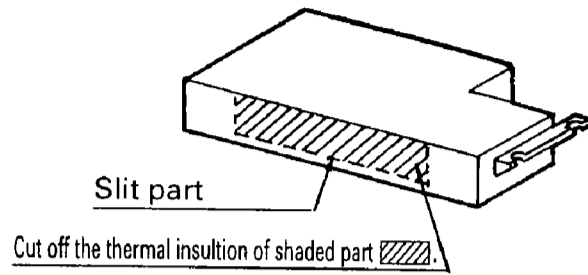
Prior to installation check whether you have the complete kit of parts as shown below including the installation manual.

Name	Flexible duct	Shutter	Thermal insulation(1)	Thermal insulation(2)	Setting plate for duct	Shutter adjuster	Flap adjuster
Shape							
Quantity							
KFDJ52F56	1 piece	1 piece	1 piece	1 piece	4 pieces	1 piece	1 piece
KFDJ52F80	1 piece	1 piece	1 piece	1 piece	6 pieces	1 piece	1 piece

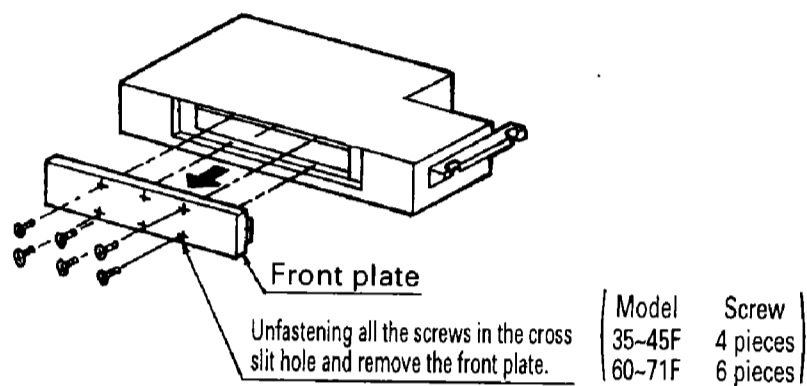
Name	Sealing pad				Installation manual	Screws		
Shape	Ⓐ	Ⓑ	Ⓒ	Ⓓ				
Quantity								
KFDJ52F56	2 pieces	1 piece	1 piece	1 piece	1 piece	Ⓐ M4×12 4 pieces	Ⓑ M5×15 4 pieces	Ⓒ M5×20 4 pieces
KFDJ52F80	—	4 pieces	—	2 pieces	1 piece	6 pieces	6 pieces	4 pieces

### ③ Preparation of indoor unit

(1) Cut off the thermal insulation on the front face of the indoor unit along with the slit furnished.



(2) Remove the front plate by unfastening all the screw.



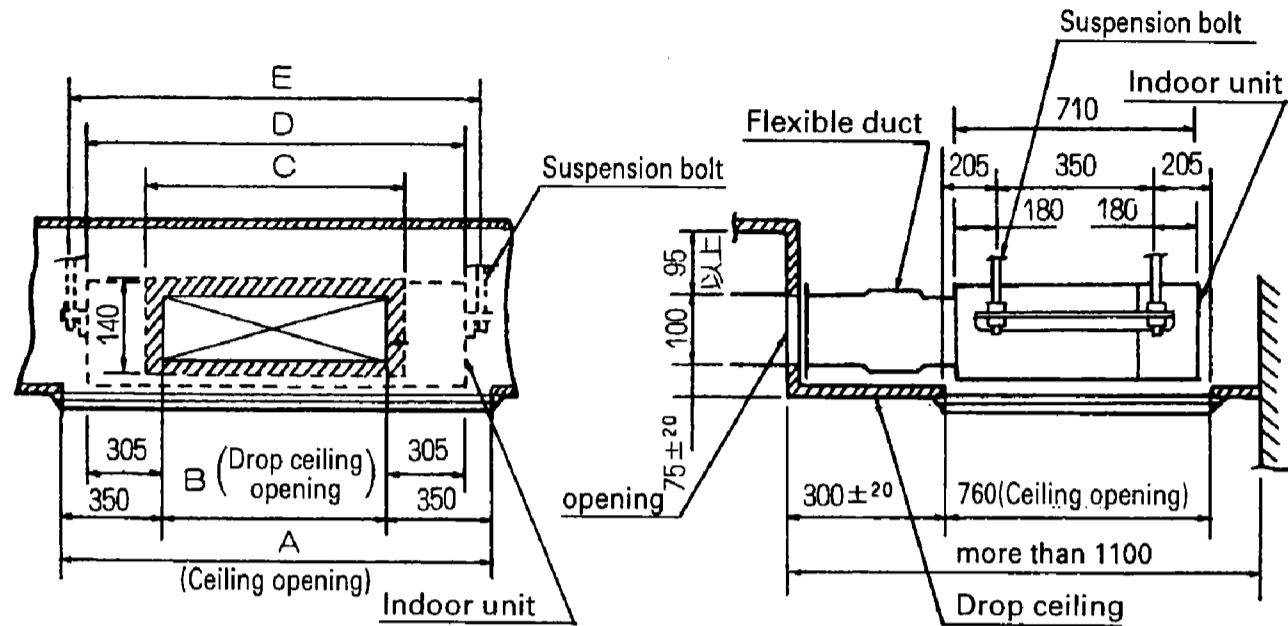
### ④ Attaching the sealing pad to the air discharge outlet

Depending on the selection of the installation pattern, attach the sealing pad as shown in the table below.

Model	Installation pattern	"Horizontal air outlet" + "Vertical air outlet"	"Horizontal air outlet"
VRV Sky Air			
25K ~ 40K	35F ~ 45F	 	 
63K	60F ~ 71F	 	 

## ⑤ Preparation prior to the installation

(1) Dimension and location of the opening of ceiling and drop ceiling, and also the suspension bolts.



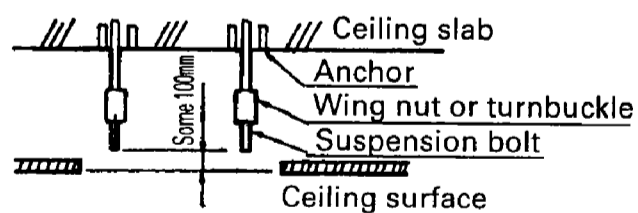
Flexible duct	A	B	C	D	E
KFDJ52F56	1200	500	540	1110	1150
KFDJ52F80	1400	700	740	1310	1350

(2) Make a opening in the ceiling for installation (If it is a existing ceiling.)

- Use the paper pattern for installation, which has been made to the dimension of the opening in the ceiling.
- Make a opening in the ceiling, and run the refrigerant piping, drain piping, wire for remote controller and transmission wiring between indoor unit and outdoor unit up to the inlet port for the piping and wiring of the indoor unit. (Refer to the related items of the installation manual of the indoor unit for its installation of the piping and wiring.)
- After making a opening in the ceiling, reinforcement of the ceiling frame and etc. may be required to maintain the level of the ceiling or to prevent the vibration of the ceiling. For details, consult with building contractor or interior contractor.

(3) Make a opening in the drop ceiling for the installation of the discharge grille. (If it is a existing ceiling)

- Never install the ceiling joint in the shaded part , which disturb the installation of the flexible duct. (Install only a ceiling material.)
- (4) Install the suspension bolts. (Use M8 size of the suspension bolts.)
- Use the hole-in anchors for the existing building and use the embedded inserts, embedded anchors for newly built ceiling so that weight of the unit is supported. Also adjust the length of the bolts to the ceiling before installing the unit.

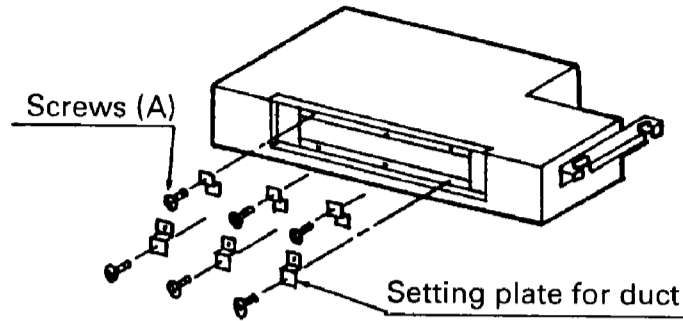


Note) All the parts shown above should be arranged locally.

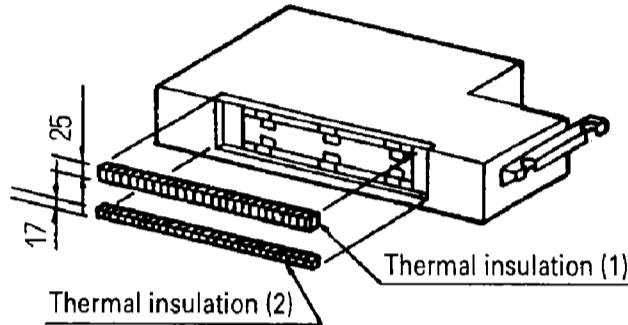
## ⑥ Installation of indoor unit

### (1) Prepare for the installation of the flexible duct

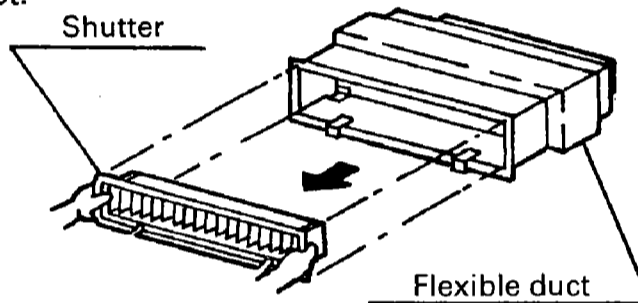
- ① Attach the setting plate for duct to the indoor unit with screws (A)(M4×12).



- ② Attach the thermal insulation (1) and (2) along the edge of opening.



### (2) Remove the shutter from the flexible duct.

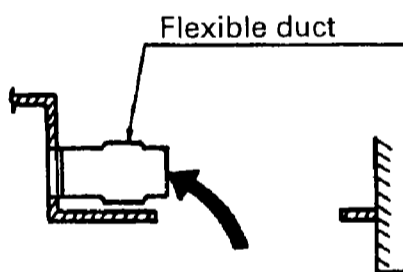


#### In case of the new ceiling

### (3) Install the indoor unit and the flexible duct

#### In case of the existing ceiling

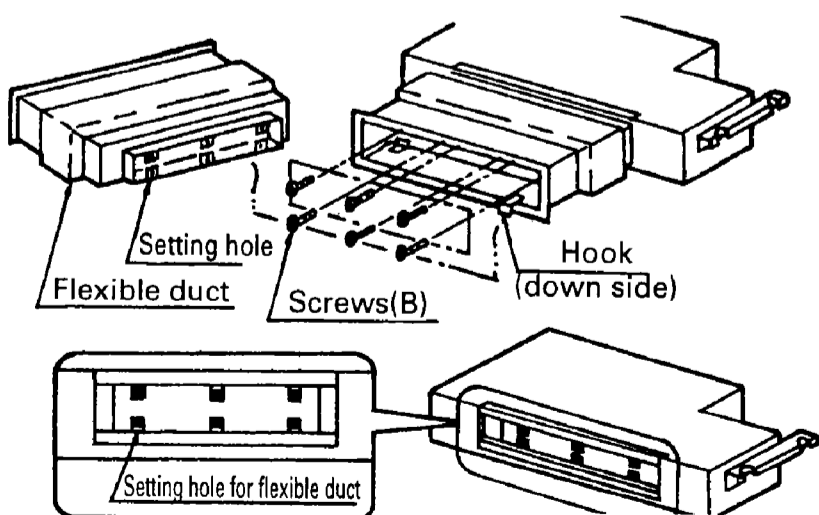
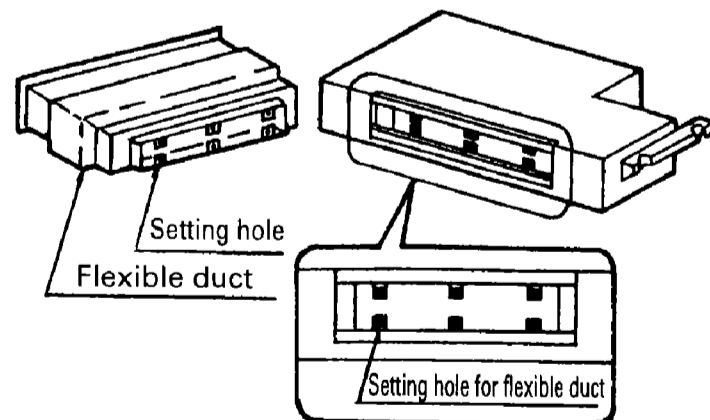
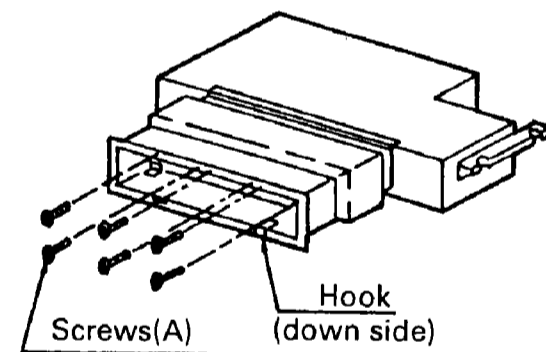
- ① Install the flexible duct temporarily in the ceiling.



- ② Refer to the installation manual of the indoor unit and install the indoor unit.

- ③ Install the flexible duct to the setting plate for duct with screws (B)(M5×15), facing the hook of flexible duct to down side.

- ① Install the flexible duct to the indoor unit with screws (B) (M5×15), facing the hook of flexible duct to down side.

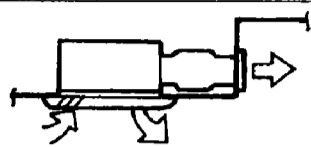
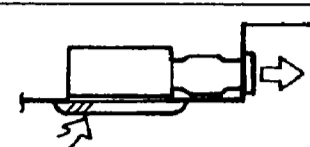
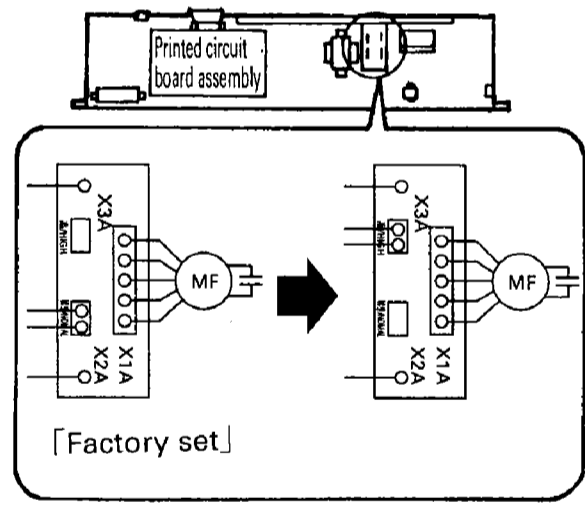
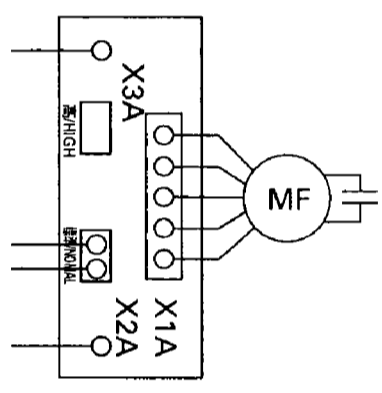


- ② Refer to the installation manual of the indoor unit and install the indoor unit (complete with flexible duct).

## ⑦ Initial setting of the indoor unit

Depending on the pattern of installation, connect the terminal board (TB) of the indoor unit as follows.

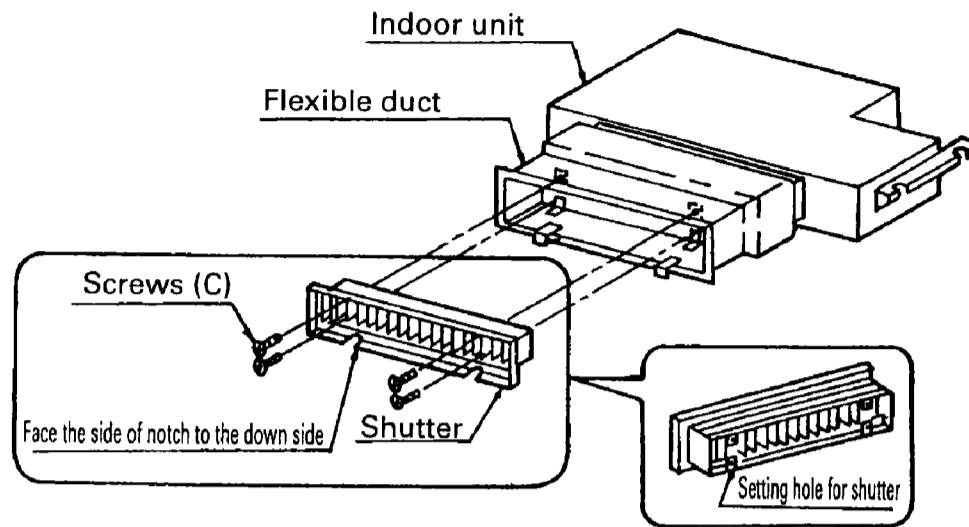
However, in case of FHYK-F type of Sky Air series, set by the remote controller at the field set mode. For details, refer to the "How to set in the field" of the operation manual of the remote controller.

Model	Installation pattern	"Horizontal air outlet" + "Vertical air outlet"	"Horizontal air outlet"										
													
3m ~ 3.8m	VRV unit	<p><b>Sky Air series</b></p> <ul style="list-style-type: none"> <li>For FHYK ~F type</li> </ul> <p>Setting number of field setting</p> <table border="1"> <thead> <tr> <th colspan="2">Mode no.</th> <th rowspan="2">Setting switch no.</th> <th rowspan="2">Setting position no.</th> </tr> <tr> <th>Group setting no.</th> <th>Individual setting no.</th> </tr> </thead> <tbody> <tr> <td>13</td> <td>23</td> <td>6</td> <td>02</td> </tr> </tbody> </table>	Mode no.		Setting switch no.	Setting position no.	Group setting no.	Individual setting no.	13	23	6	02	<p><b>Sky Air series</b> No setting required.</p> <p>No field setting required by the remote controller.</p>
		Mode no.		Setting switch no.			Setting position no.						
Group setting no.	Individual setting no.												
13	23	6	02										
		<p><b>VRV unit</b></p>  <p>[Factory set]</p>	<p><b>VRV unit</b> No setting required.</p>  <p>Not possible</p>										

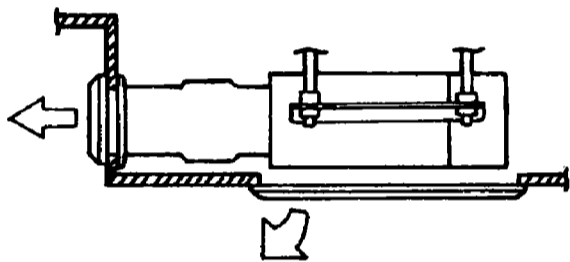


## ⑧ Installation of the shutter and its adjustment

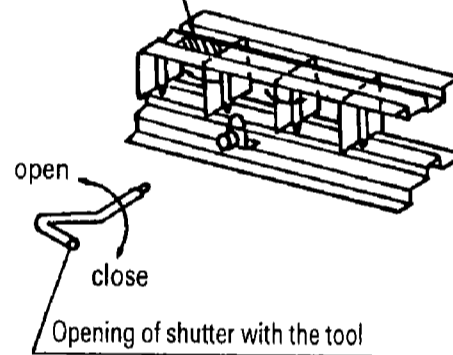
(1) Install the shutter in the inside of the flexible duct with screws (C)(M5×20).



(2) When the unit is installed with the pattern of the "Horizontal air outlet" + "Vertical air outlet", by referring to the following table, adjust the opening of shutter with the tool according to the height of the ceiling as directed in the name plate for the opening of shutter.



Name plate for the opening of shutter



Opening of shutter	Proportion of the air volume		Ceiling height
	"Horizontal air outlet"	"Vertical air outlet"	
Full close	Never operate the unit with the shutter at "full close".		
25%	4	6	3~3.8m
50%	5	5	~3m
75%	5.5	4.5	
Full open	6	4	

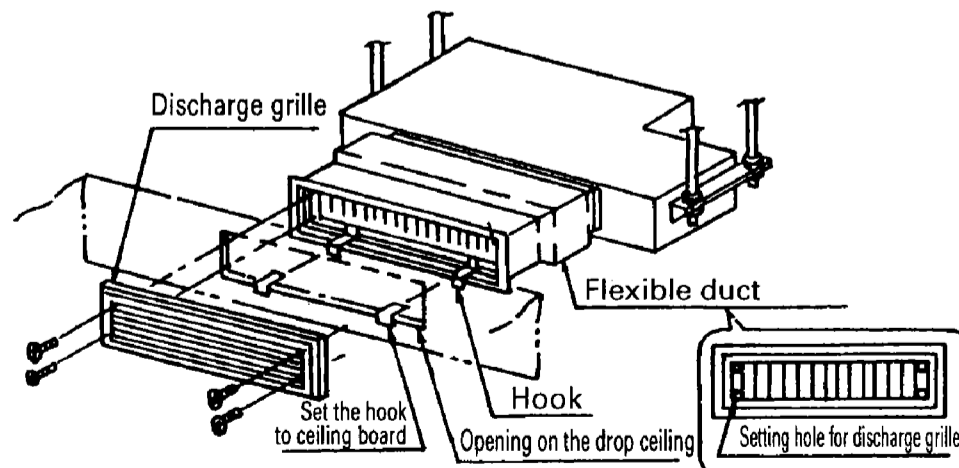
### Caution

Be sure to set the shutter at "full open" when the unit is operated with "Horizontal air outlet" only.

## ⑨ Installation of the discharge grille

(1) Before installing the discharge grille, set the hook for duct to the lower side of the opening.

(2) Install the discharge grille to the flexible duct with screws (M5×50) (included in the discharge grille kit) over the drop ceiling board.



## ⑩ Installation of the decoration panel to the indoor unit

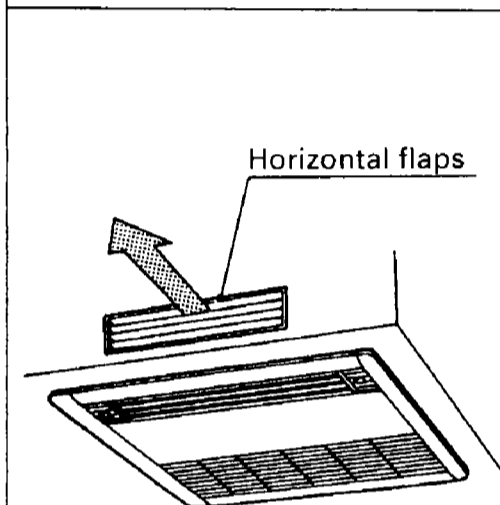
- Install the decoration panel according to the pattern of the installation.

"Horizontal air outlet" and "Vertical air outlet"	"Horizontal air outlet"	
	When the air discharge blind panel is not installed.	When the air discharge blind panel is installed.
Refer to the installation manual of the decoration panel, install the decoration panel to the indoor unit.		Refer to the installation manual of the air discharge blind plate, install the decoration panel to the indoor unit.

## ⑪ Adjusting the direction of air discharge

How to adjust the blow direction depending on the unit set-up.

In case of "Horizontal air outlet" ...When the air discharge unit is used.

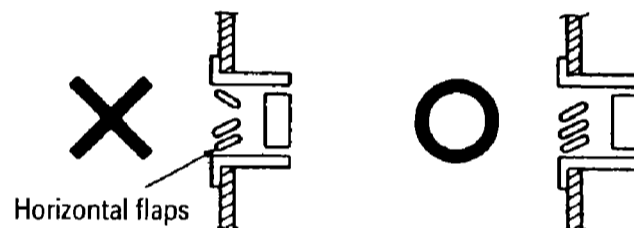


- Up / Down adjustment when cooling

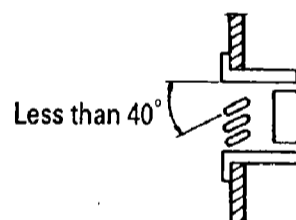
Keep the horizontal flaps of discharge grille at horizontal position.

### Caution

1. When you set the flaps downward, keep all the horizontal flaps same direction as shown below. Never set the flaps with sharp bend to disturb the air flow, which may cause the condensation on the discharge grille.

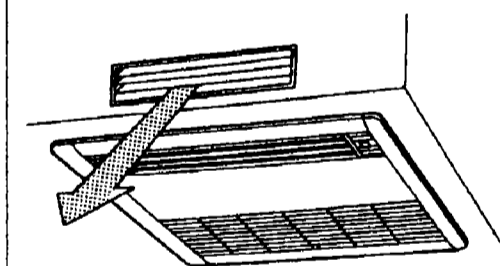


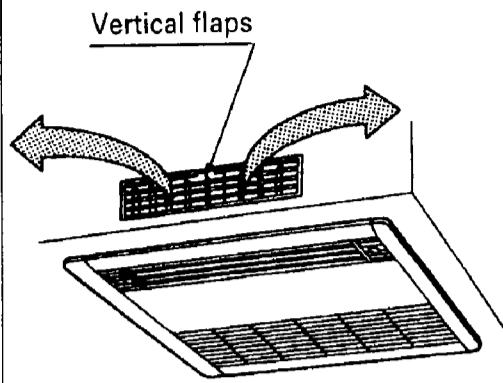
2. Keep the horizontal flap to a 40° angle or less. If the flaps are set to a 40° angle or more, it may cause the condensation on the grille.



- Up / Down adjustment when heating

Set the horizontal flaps of the discharge grille downward.



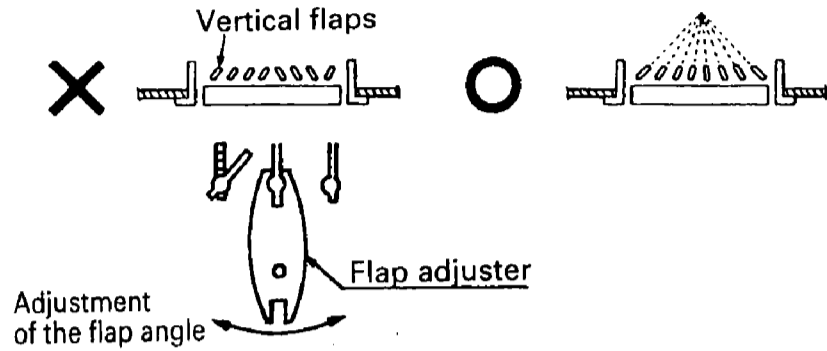


● Right / Left adjustment

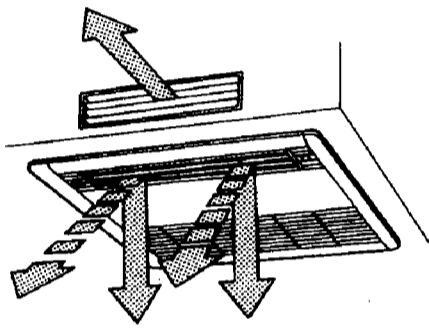
Adjust the vertical flaps of the discharge grille to the right and left by the flap adjuster (included in the kit) in order to have an appropriate distribution of the room temperature.

**Caution**

When you adjust the vertical flaps to the right and left side, adjust the flaps as shown below. If you set the flaps with a sharp bend and it disturbs the air flow, it may cause the condensation of the discharge grille.



In case of "Horizontal air outlet" ...When the air discharge unit is used.



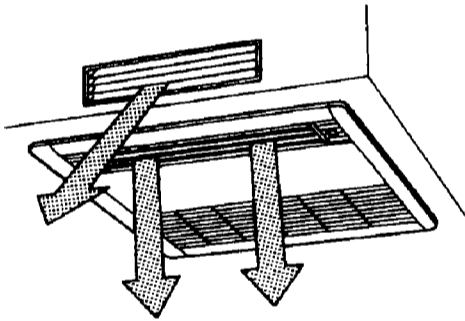
● Up / Down adjustment for cooling operation

For "Horizontal air outlet" refer to the above and adjust the flaps Up / Down of the front discharge grille.

For "Vertical air outlet", refer to the operation manual of the indoor unit for "Adjustment of air direction by remote control".

**Caution**

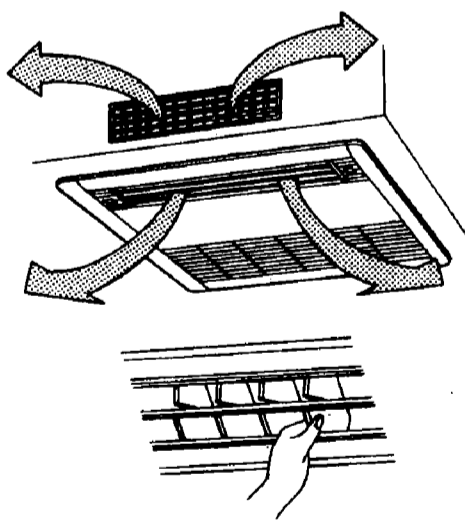
When the unit is operated for a long period of time in high humid place, it may cause the condensation on the panel. In this case, set the flaps of the discharge grille downward or swing the flaps.



● Up / Down adjustment for heating operation

For "Horizontal air outlet", refer to the above and adjust the flaps Up / Down of the front discharge grille.

For "Vertical air outlet", refer to the operation manual of the indoor unit for "Adjustment of the direction of the air flow by remote controller".



● Right / Left adjustment for heating operation

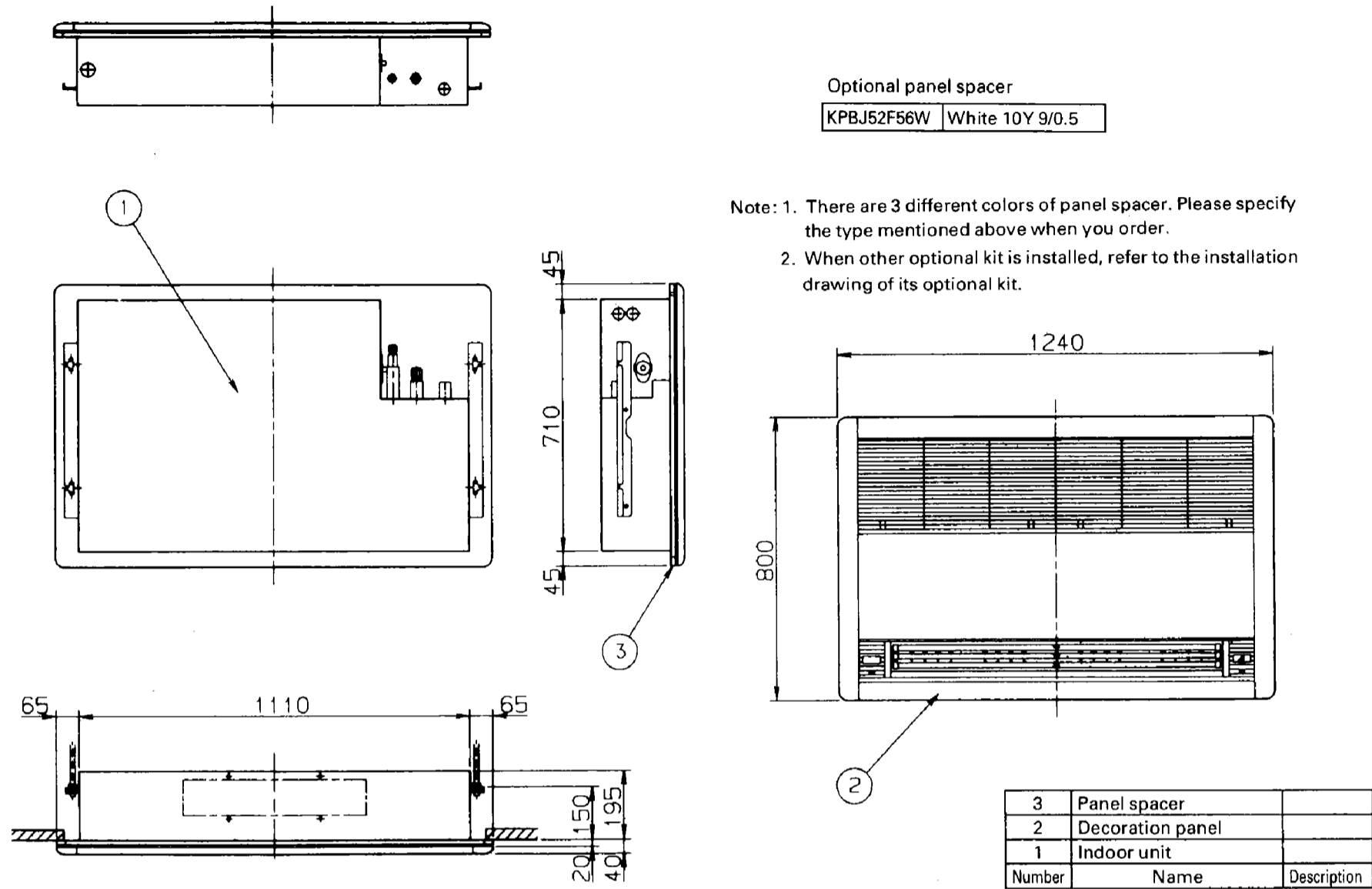
For "Horizontal air outlet" refer to the above and adjust the flaps Right / Left of the front discharge grille.

For "Vertical air outlet", adjust the vertical flaps of the discharge grille to Right / Left to obtain an appropriate distribution of the room temperature.

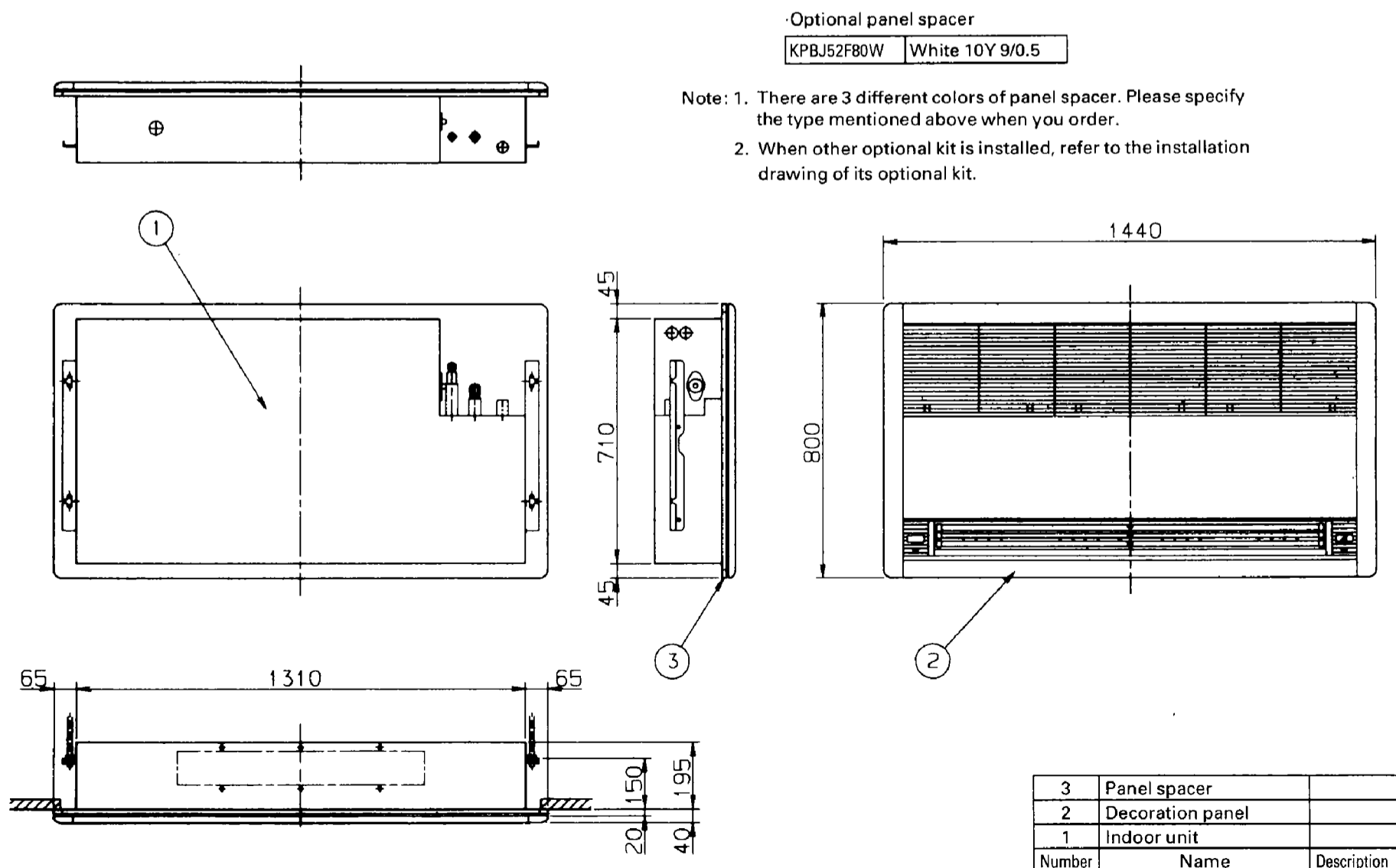
## 9.7 Optional kit installation drawing

### Panel spacer

#### ● Panel spacer (KPBJ52F56W)+Ceiling mounted cassette Corner type (For indoor unit 35F~45F)

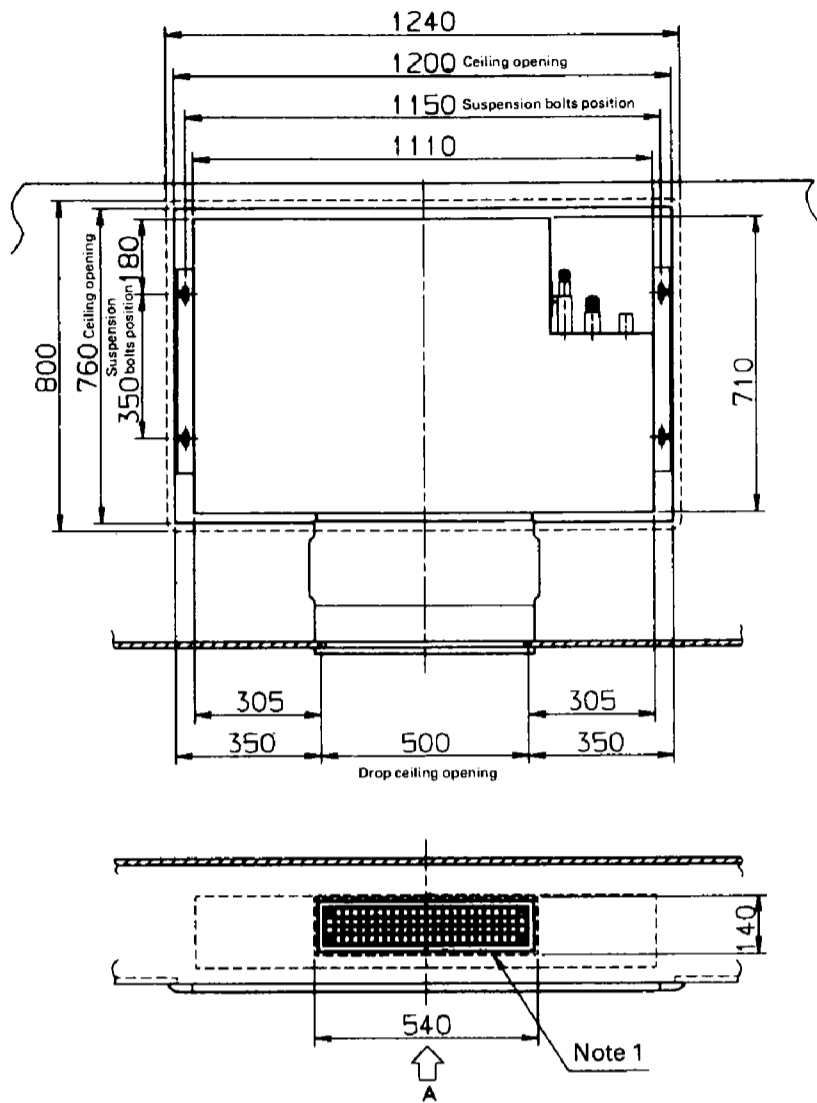


#### ● Panel spacer (KPBJ52F80W)+Ceiling mounted Cassette Corner Type (For indoor unit 60~71F)

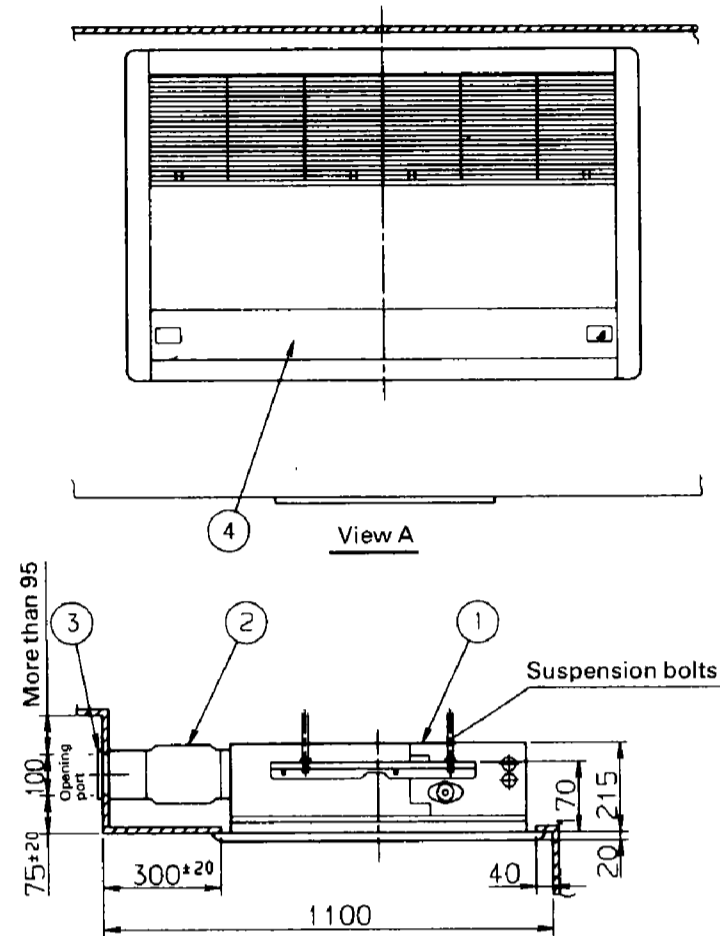


## Air discharge blind panel, Discharge grille and Flexible duct

- Air discharge blind panel (KDBJ52F56W) + Discharge grille (KDGJ52F56W) + Flexible duct (KFDJ52F56) + Ceiling mounted cassette corner type (for indoor unit 35F~45F)

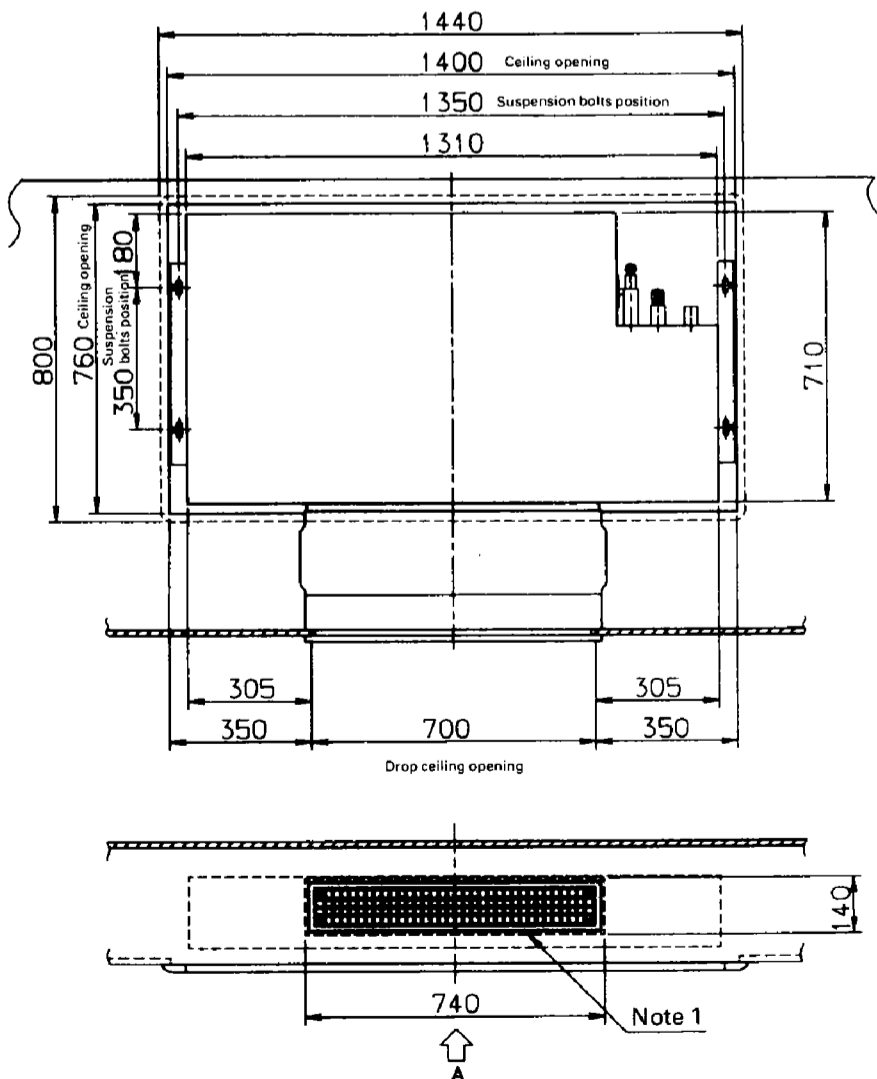


Note: 1. Do not obstruct around the drop ceiling opening.

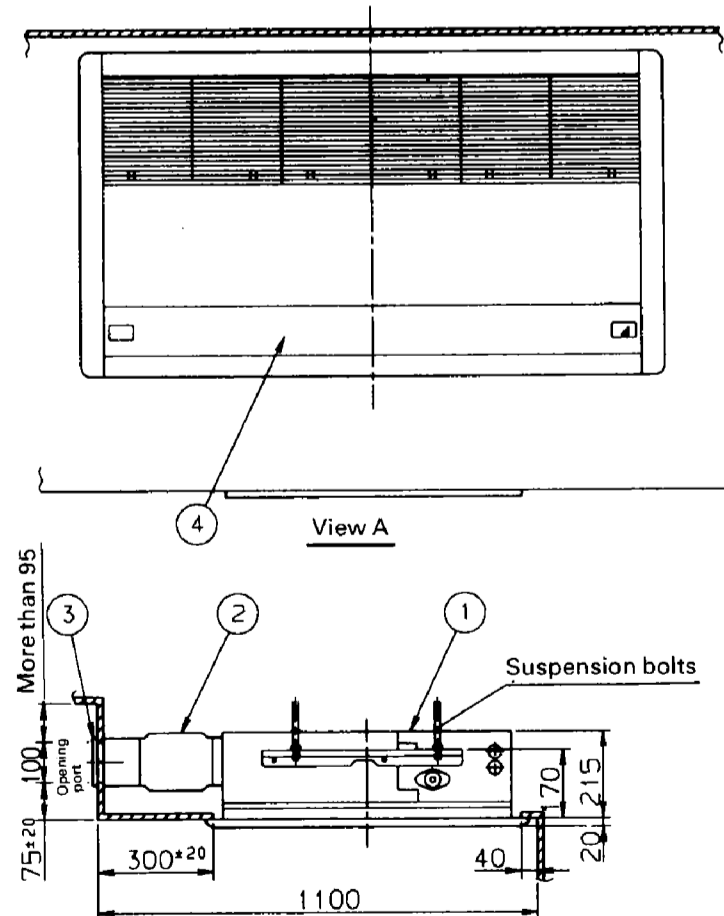


4	Air discharge blind panel	
3	Discharge grille	
2	Flexible duct	
1	Indoor unit	
Number	Name	Description

- Air discharge blind panel (KDBJ52F80W) + Air discharge grille (KDGJ52F80W) + Flexible Duct (KFDJ52F80) + Ceiling mounted cassette Corner type (For indoor unit 60F~71F)



Note: 1. Do not obstruct around the drop ceiling opening.



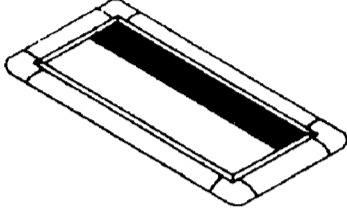
4	Air discharge blind panel	
3	Discharge grille	
2	Flexible duct	
1	Indoor unit	
Number	Name	Description

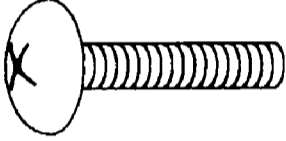
# 10 Ceiling mounted built-in type [FH(Y)B]

## 10.1 Decoration panel – BYBS45D-W2-71D-W2-125D-W2

### ① Check of the parts

- The box contains this manual and the parts listed below.

Item	Description	Quantity
Decoration panel		1 set

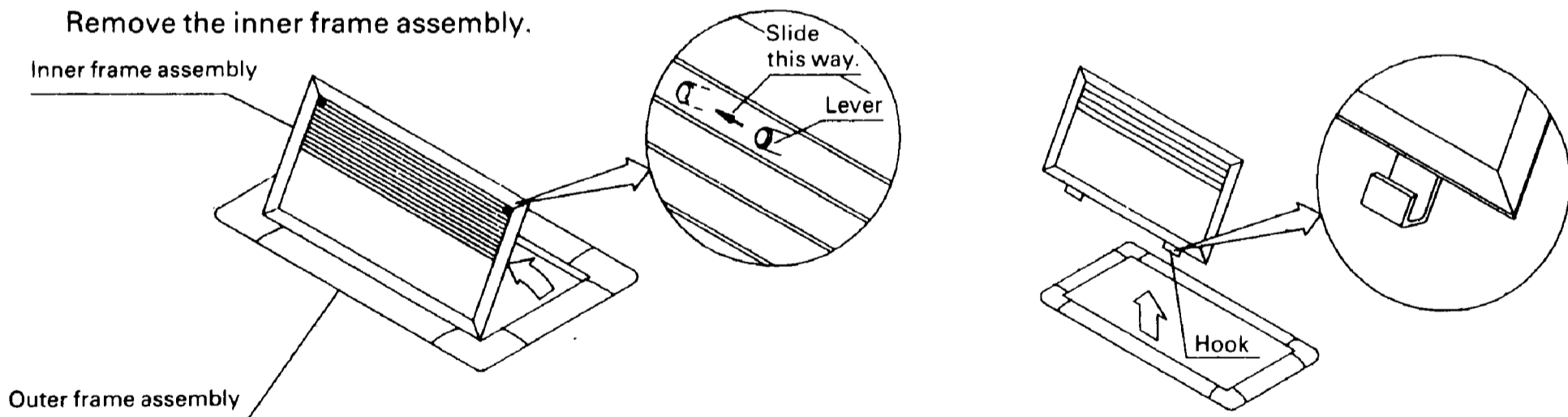
Item	Description	Quantity
Decoration panel fixing screw	 M5×40	4 pcs.

### ② Preparing the decoration panel

- Handle the suction panel with care.

< Never lean the panel against a wall, etc. nor leave it on a projecting object. (For preventions of dents or damages to the panel surface.) >

Remove the inner frame assembly.



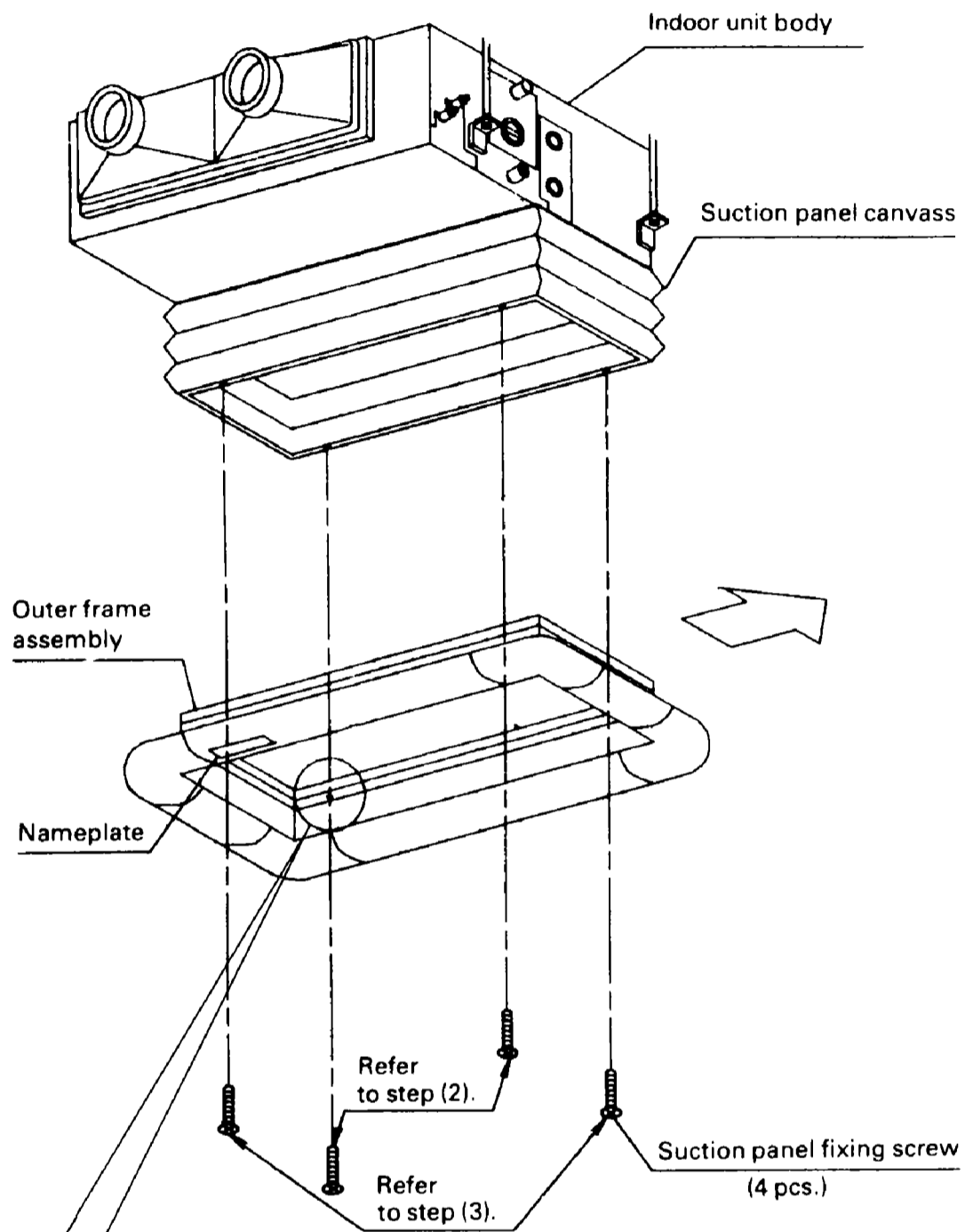
- Slide the inner frame assembly's lever and pull up the inner frame assembly.
- Unhook the inner frame assembly off the hook holes.

### ③ Installing the outer frame assembly

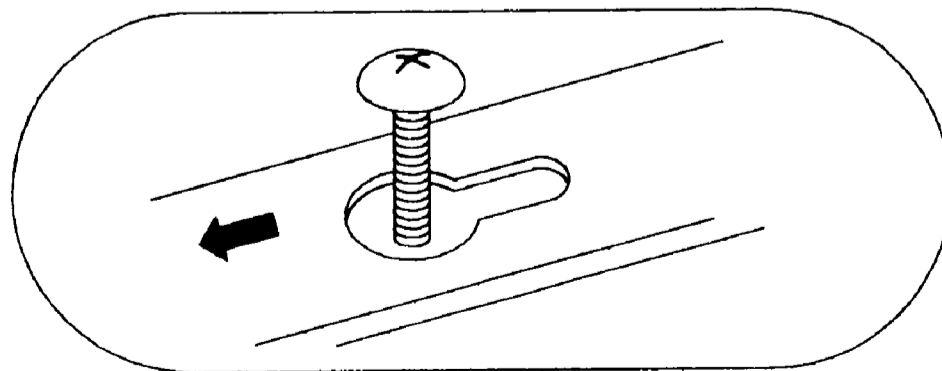
- This decoration panel can be installed to the air-conditioner body either directly or using a canvas for decoration panel (optional).

#### 1. For installation using the decoration panel canvas

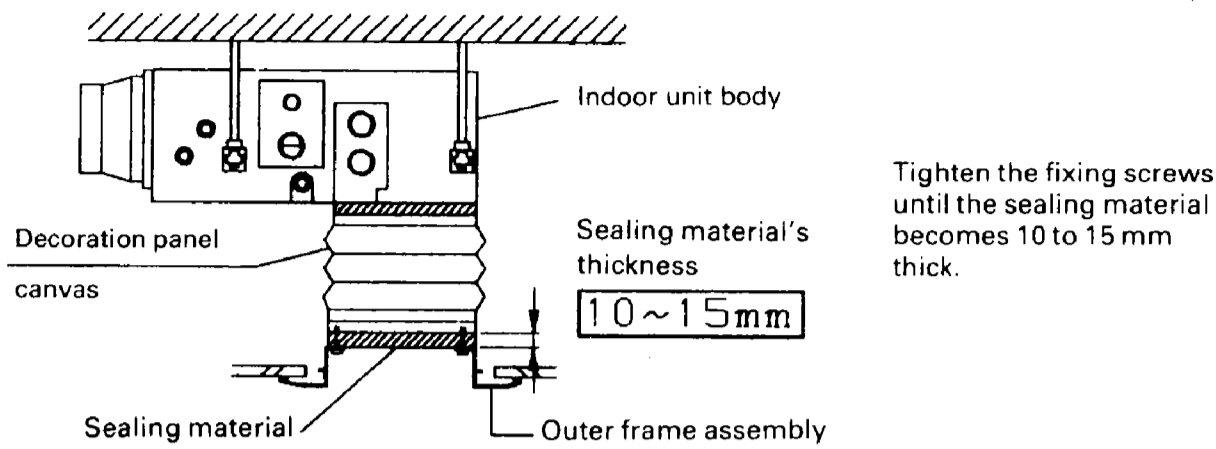
<Read also the instruction manual accompanying the decoration panel canvas.>



- (1) Install the decoration panel canvas to the indoor unit body. (Make the tightening length of the screws about 10 mm.)
- (2) Mount two suction decoration panel fixing screws to the decoration panel canvas and temporarily tighten them.
- (3) Move the outer frame assembly in the direction of the arrow to rest it on the two screws temporarily.



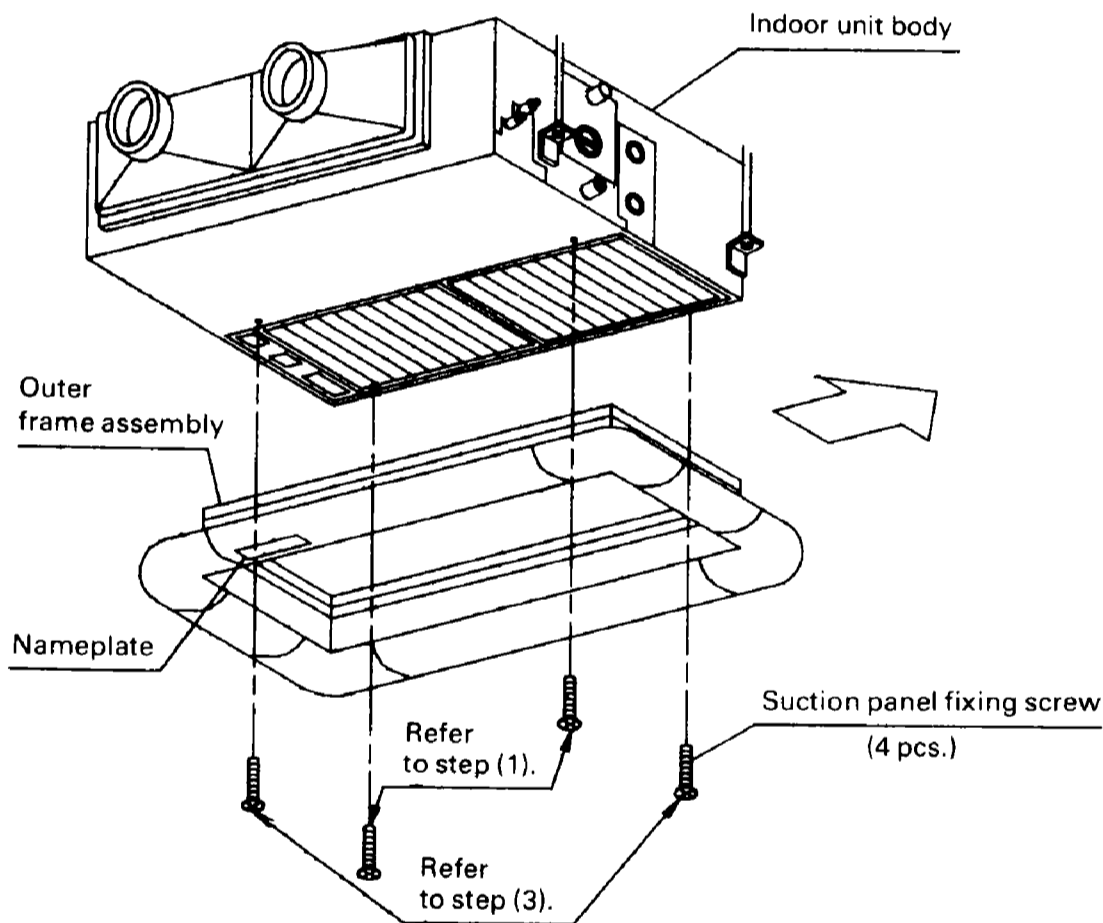
- (4) Mount the rest two screws to the suction panel canvass and tighten all the four screws securely until the sealing material becomes 10 to 15 mm thick.



- (5) Use the chain and turnbuckle supplied for the decoration panel canvas to make no gap between the canvas and the ceiling

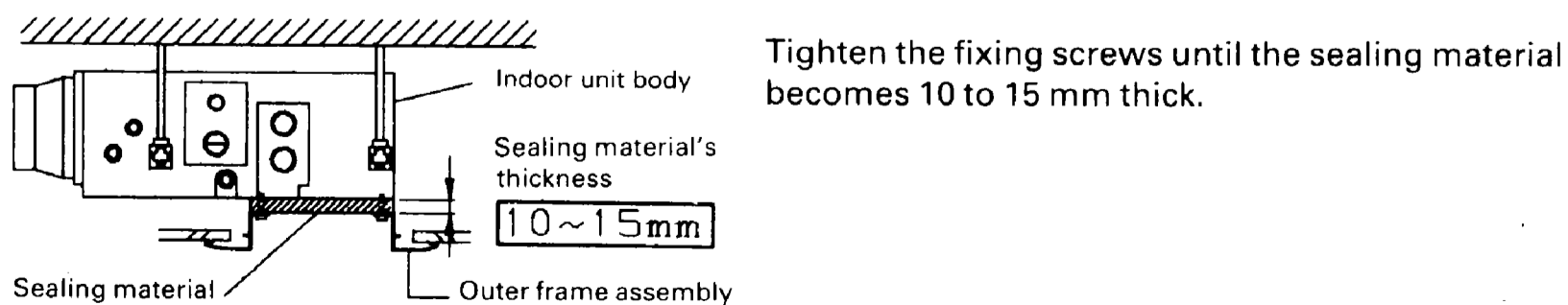
<Install the suction panel to the indoor unit body in the correct direction with the nameplate on the panel coming to the position shown in the left figure.>

## 2. For direct installation



- (1) Mount two decoration panel fixing screws to the indoor unit body and tighten them temporarily. (Make the tightening length of the screws about 10 mm.)
- (2) Move the outer frame assembly in the direction of the arrow to rest it on the two screws temporarily.
- (3) Install the outer frame assembly by following the steps (3) and (4) in "1. For installation using the decoration panel canvas".

**Note:** In case there is a gap between the decoration panel and the ceiling, adjust the height of the indoor unit. (Refer to the indoor unit installation manual.)

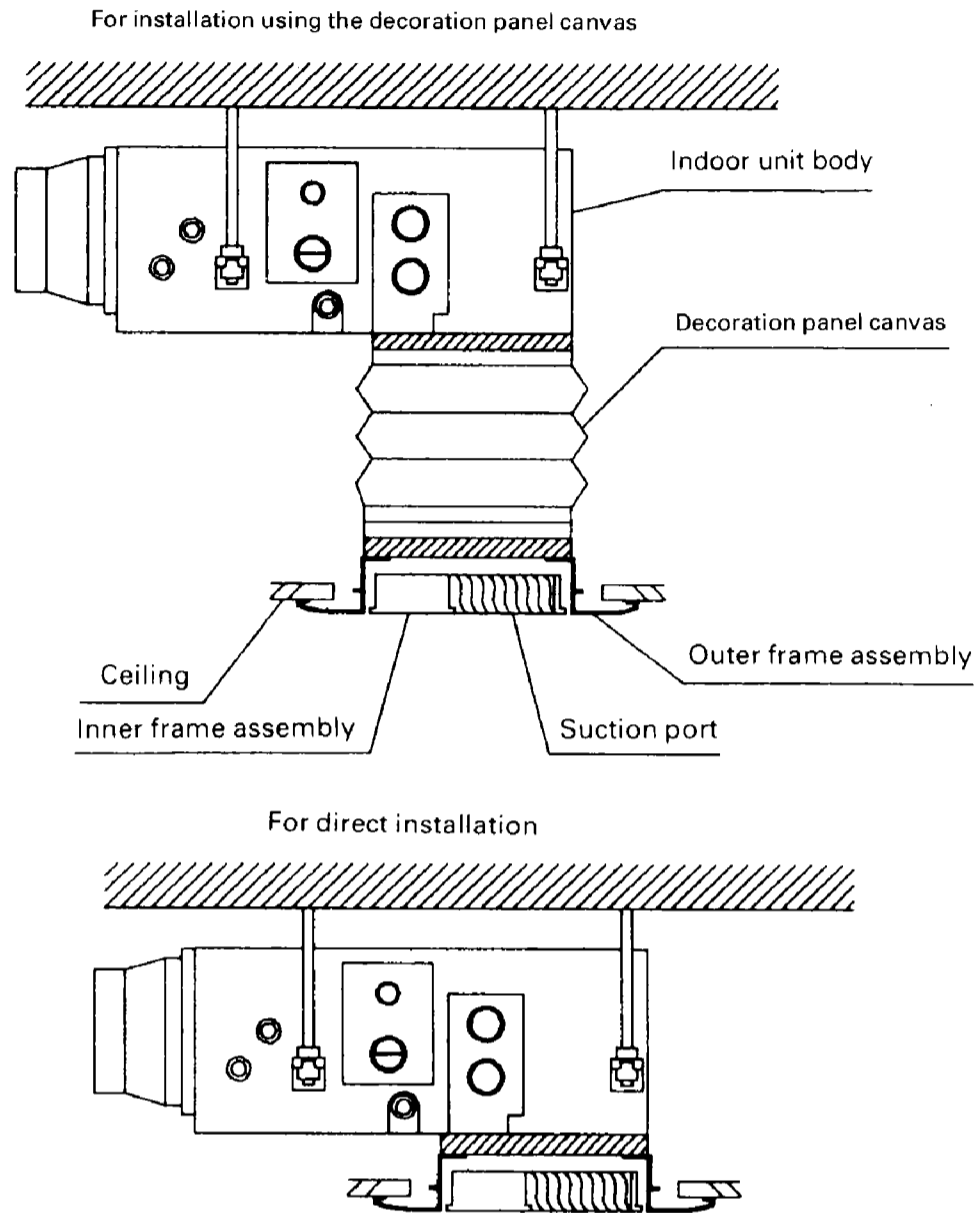


<Install the decoration panel to the indoor unit body in the correct direction with the nameplate on the panel coming to the position shown in the left figure.>

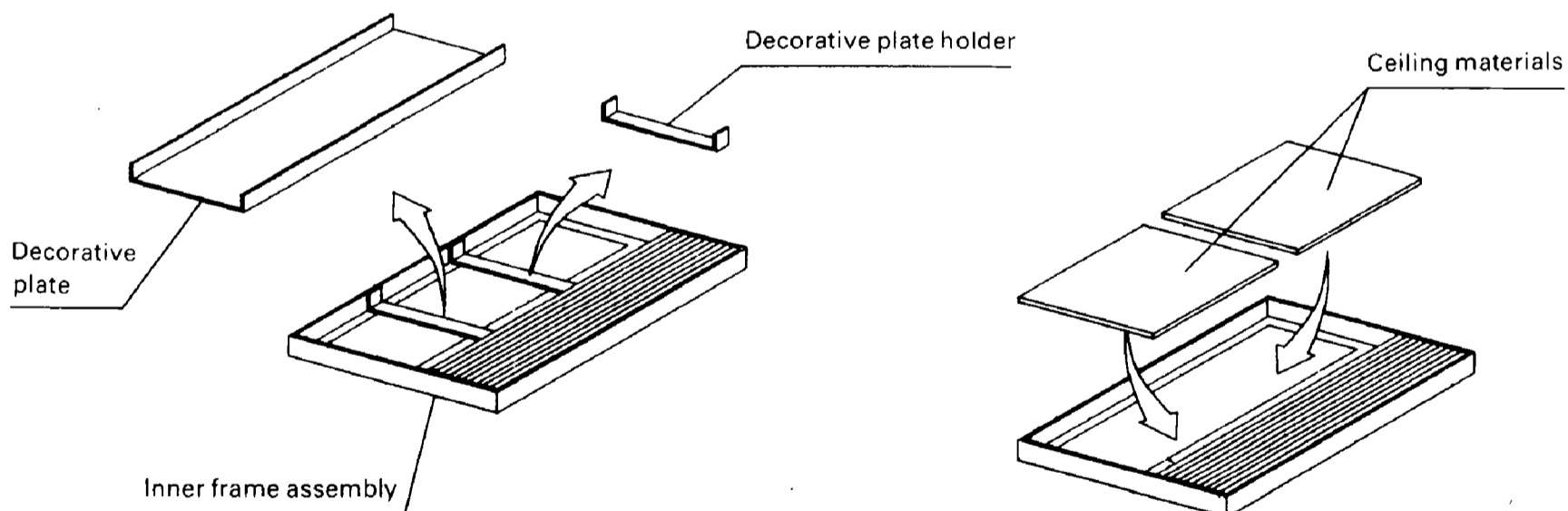


#### ④ Installing the inner frame assembly

- Install the inner frame assembly to the outer frame assembly by following the reverse steps mentioned in "2. Preparing the decoration panel".



< Ceiling materials can be attached to the inner frame assembly. For their installation, take the following steps. >



- (1) Remove the decorative plate holder from the inner frame assembly.
- (2) Remove the decorative plate and place the ceiling materials instead.
- (3) Using the decorative panel holder removed in the step (1), fix the ceiling material.

**Note:**

Installation of the ceiling materials makes the decorative panel unnecessary. Make the ceiling materials less than 15 mm thick.

## 10.2 Service access panel – KTBJ25K56W-80W-160W

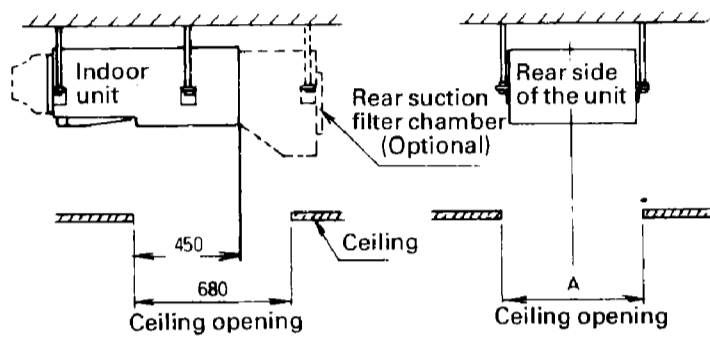
### ● Specifications

Item		KTBJ25K56W	KTBJ25K80W	KTBJ25K160W
Model				
Color		White		
Dimensions (mm)	Width	776	1,076	1,476
	Depth	698		
	Height	Exposed part : 10      Concealed part : 30		
Applicable model		For indoor unit 35F~45F	For indoor unit 60F~71F	For indoor unit 100F~125F

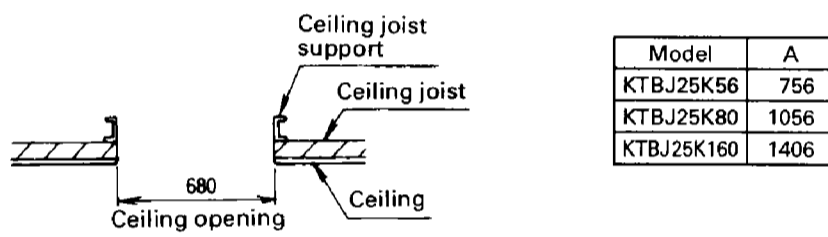
### ● Installation

[Before installation]

#### 1. Make an opening on the ceiling



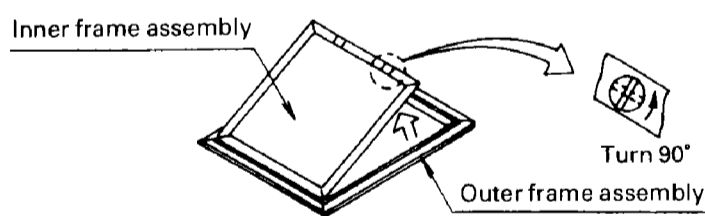
#### 2. Install ceiling joist supports to fit the ceiling opening



[Installation]

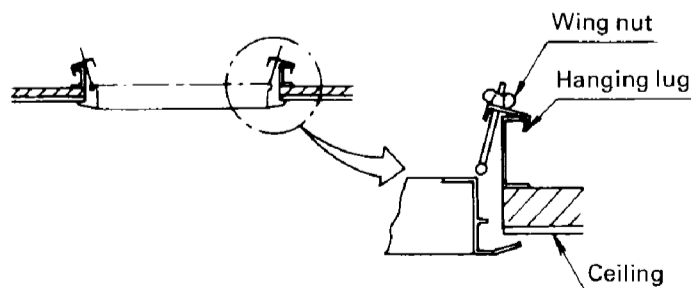
#### 1. Remove inner frame assembly

- Inner frame assembly can be removed by turning the retainer 90° with screwdriver.

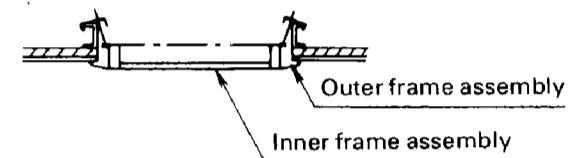


#### 2. Install outer frame assembly on the ceiling.

- Hook the hanging lug on the ceiling joist support, and tighten the wing nut to fix the frame assembly.



#### 3. Install the inner frame assembly on the outer frame assembly.



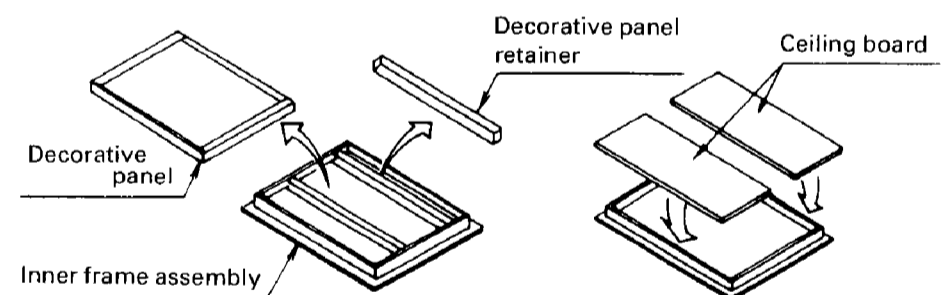
[Installation of the ceiling board]

The ceiling board can be installed into the inner frame assembly as follows.

- ① Remove decoration panel retainer from the inner frame assembly.
- ② Remove the decoration panel and substitute with the ceiling board.
- ③ Set the ceiling board by retainer removed in step ① of above.

(Cautions)

When the ceiling board is installed, the decoration panel is not needed.



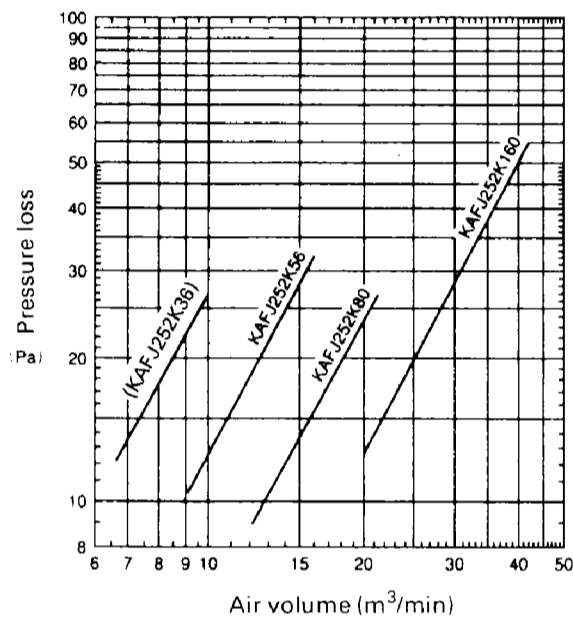
## 10.3 High-efficiency filter – KAFJ252K56-80-160 KAFJ253K56-80-160

### ● Specifications

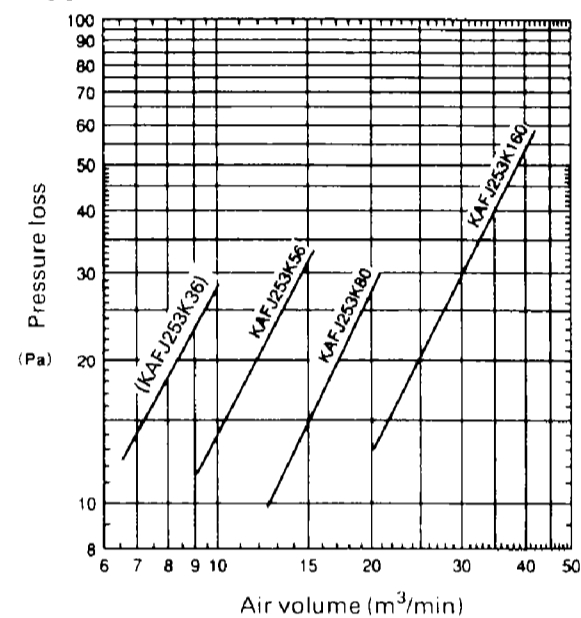
Model	Item	KAFJ252K56	KAFJ252K80	KAFJ252K160	KAFJ253K56	KAFJ253K80	KAFJ253K160
Efficiency	%	65%(NBS colorimetric method)			90%(NBS colorimetric method)		
Initial pressure loss	(Pa)	less than 49(5mmH <sub>2</sub> O)			less than 49(5mmH <sub>2</sub> O)		
Ultimate pressure loss	(Pa)	98(10mmH <sub>2</sub> O)			98(10mmH <sub>2</sub> O)		
Filter materials		Synthetic fiber non woven fabric			Synthetic fiber non woven fabric		
Effective life	h	2,500 hours (dust particle concentration at 0.15mg/m <sup>3</sup> )			1,800 hours (dust particle concentration at 0.15mg/m <sup>3</sup> )		
Dimensions (mm) (T×W×D)		(55×650×360)×1	(55×475×360)×2	(55×700×360)×1 (55×650×360)×1	(55×650×360)×1	(55×475×360)×2	(55×700×360)×1 (55×650×360)×1
Applicable model		For indoor unit 35F~45F	For indoor unit 60F~71F	For indoor unit 100F~125F	For indoor unit 35F~45F	For indoor unit 60F~71F	For indoor unit 100F~125F

### ● Characteristics of filter

#### ● NBS 65% type



#### ● NBS 90% type

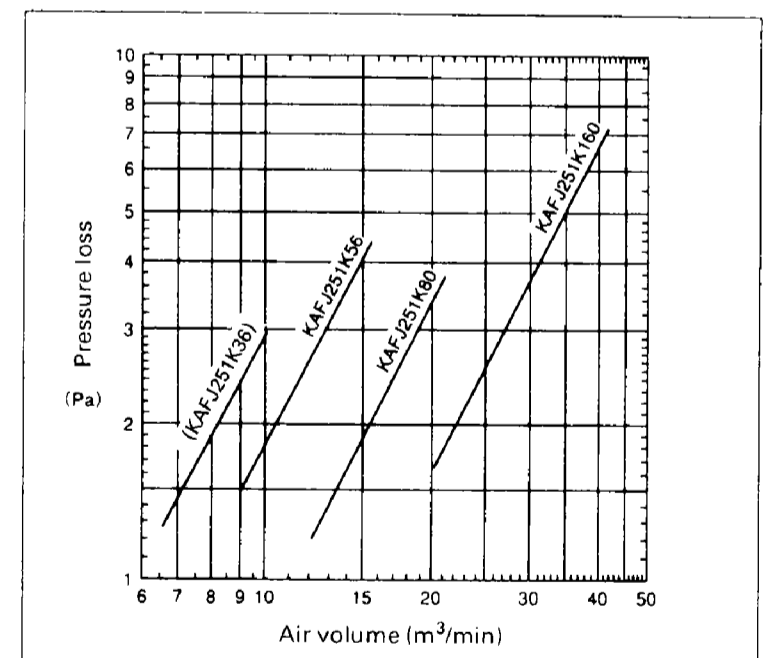


## 10.4 Replacement long-life filter – KAFJ251K56-80-160

### ● Specifications

Model	Item	KAFJ251K56	KAFJ251K80	KAFJ251K160
Dimensions (mm) (T×W×D)		20×656×377	20×506×377 20×451×377	20×701×377 20×656×377
Average efficiency	%	50% (by weight method)		
Pressure loss (Pa)	Initial	9.8(1mmH <sub>2</sub> O)		
	Ultimate	49(5mmH <sub>2</sub> O)		
Filter materials		Mold prevention resin net		
Number of filters		1	2 (each one)	2 (each one)
Effective life (h)		2500 hours(at dust particle concentration of 0.15/m <sup>3</sup> )		
Applicable model		For indoor unit 35F~45F	For indoor unit 60F~71F	For indoor unit 100F~125F

### ● Characteristics of filter



## 10.5 Filter chamber for bottom suction KAJ25K56D · 80D · 160D

### ● Applicable model

Model	High efficiency filter kit		Applicable model
	65%	90%	
KAJ25K56D	KAFJ252K56	KAFJ253K56	For indoor unit 35F~45F
KAJ25K80D	KAFJ252K80	KAFJ253K80	For indoor unit 60F~71F
KAJ25K160D	KAFJ252K160	KAFJ253K160	For indoor unit 100F~125F

### 1. Contents of kit

Name	Quantity		
	KAJ25K56D	KAJ25K80D	KAJ25K160D
Filter chamber for bottom suction	1	1	1
Panel setting plate	4	4	4
Screws for panel setting plate	4	4	4
Screws	4	4	4
Installation manual	1	1	1

### 2. Tools required for the installation

Screw driver ⊕

### 3. Installation of the filter chamber for bottom suction

- (1) Remove the long life filter (standard accessory) from the indoor unit. (Fig. 1)
- (2) Installation of the filter chamber for bottom suction.
  - ① Set the 2 screws for the filter chamber to the indoor unit temporarily. (Leave 30mm)
  - ② Set the filter chamber on the screws and slide the filter chamber to hook on the screws temporarily. (Fig. 3)
  - ③ Set the remaining 2 screws and tighten all of 4 screws until the thickness of the sealing material becomes 10 ~15mm.
- (3) Attach the panel setting plate to the filter chamber for bottom suction. (Fig. 2)
- (4) Set the high efficiency filter (optional kit) with the retainer (Fig. 2).

### 4. Caution

- Be sure to install properly according to this installation manual.
- Refer to the drawing on the right for the direction of the filter.

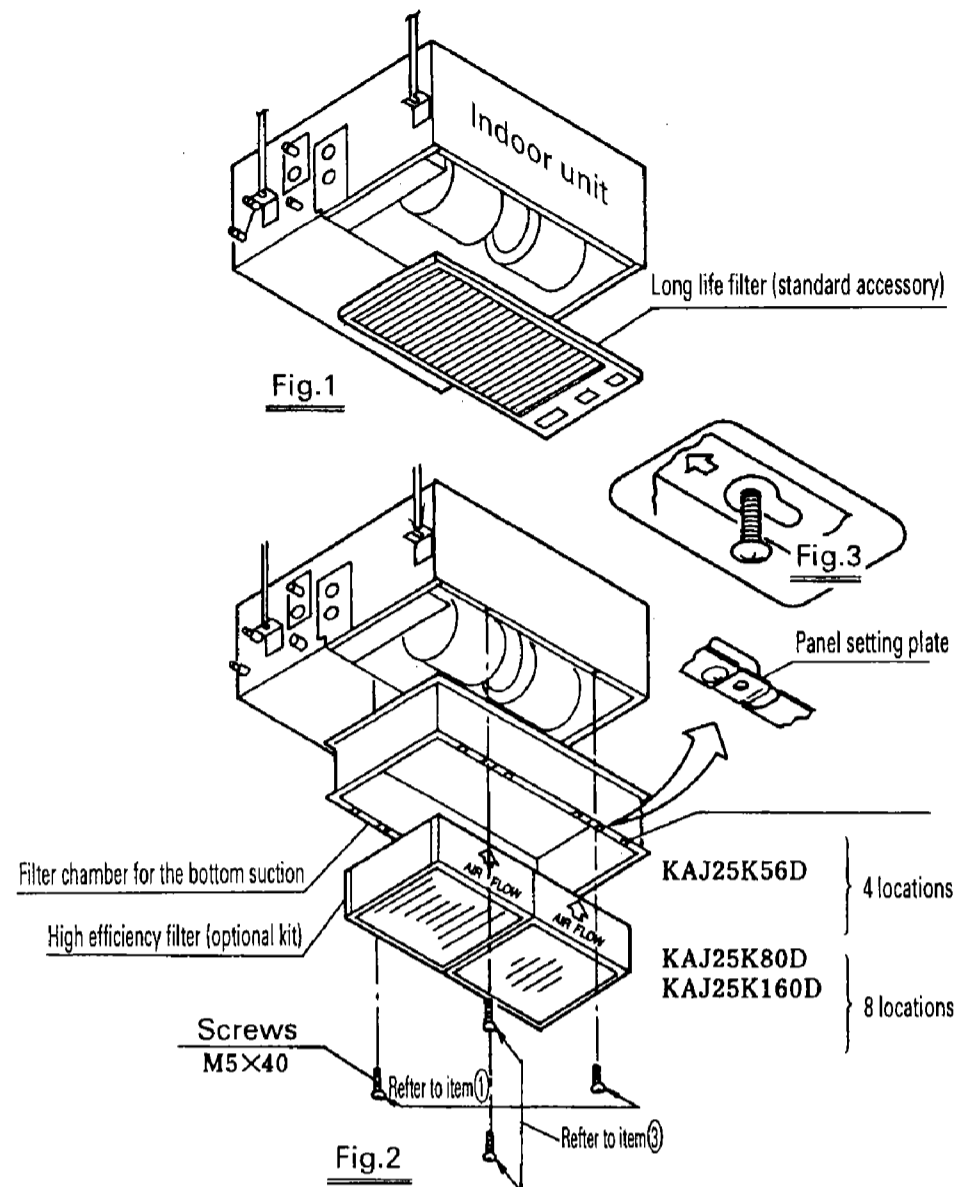
## 10.6 Filter chamber for rear suction KAJ25K56B · 80B · 160B

### ● Applicable model

Model	High efficiency filter kit		Applicable model
	65%	90%	
KAJ25K56B	KAFJ252K56	KAFJ253K56	For indoor unit 35F~45F
KAJ25K80B	KAFJ252K80	KAFJ253K80	For indoor unit 60F~71F
KAJ25K160B	KAFJ252K160	KAFJ253K160	For indoor unit 100F~125F

### Contents of kit

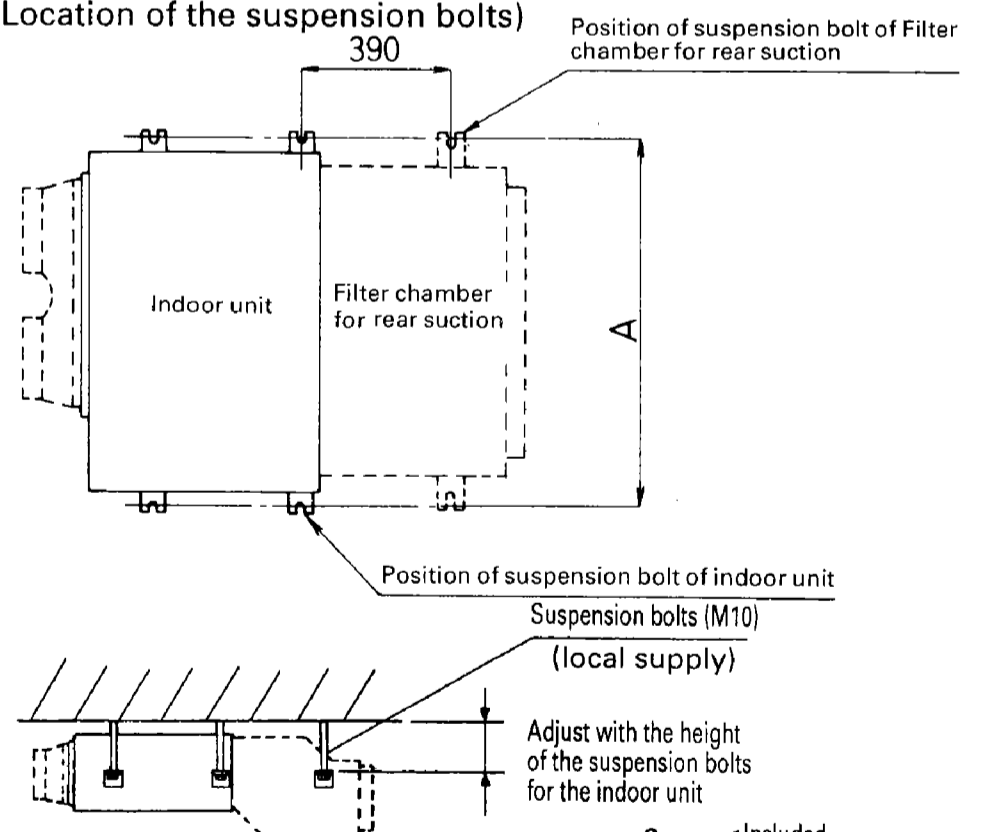
Name	Quantity		
	KAJ25K56B	KAJ25K80B	KAJ25K160B
Filter chamber for rear suction	1	1	1
Blank plate for rear suction	1	1	1
Screws (M5×12)	For blank plate	4	6
	For filter chamber	11	13
Washer for suspension bracket	4	4	4
Suspension bracket	2	2	2
Screws for suspension bracket (M5×12)	2	2	2



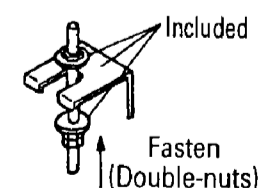
### Preparation before installation

#### ① Attach the hanging bolts.

(Location of the suspension bolts)

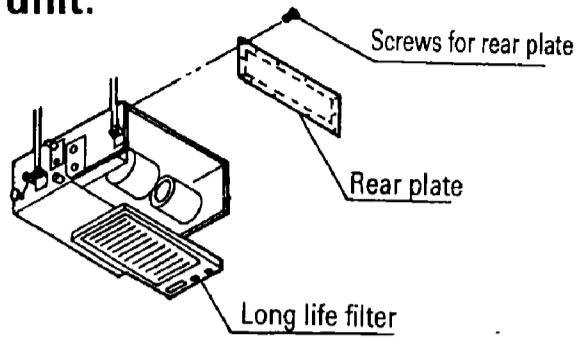


Use a hole-in-anchor, sunken insert, sunken anchor and etc. to support the weight of the unit sufficiently.



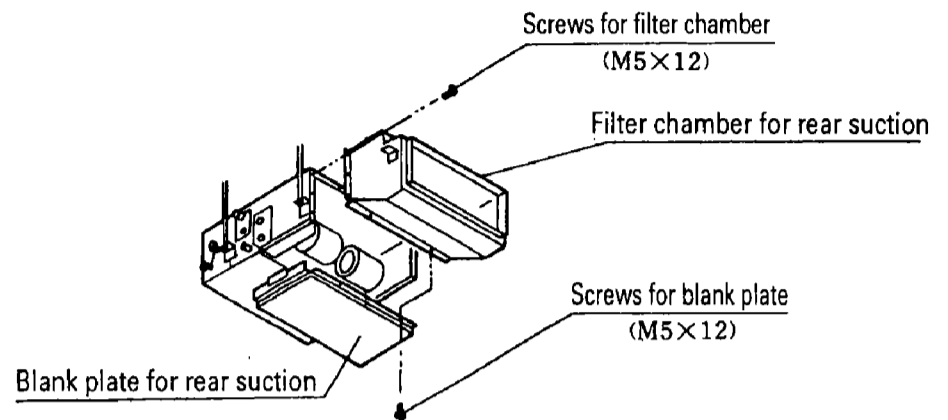
## Installation of the filter chamber for rear suction

- Remove the long life filter and the rear plate of the indoor unit.



- Install the filter chamber for rear suction to the suspension bolts with nut and washer temporarily.
- Fix the filter chamber for rear suction to the indoor unit with screws.

- Fix the filter chamber for rear suction to the suspension bolts.
- Attach the blank plate for rear suction to the bottom of the indoor unit with screws.



## Installation of the filter

### In case the long life filter is used.

(Long life filter of standard accessory is used.)

#### Installation of long life filter

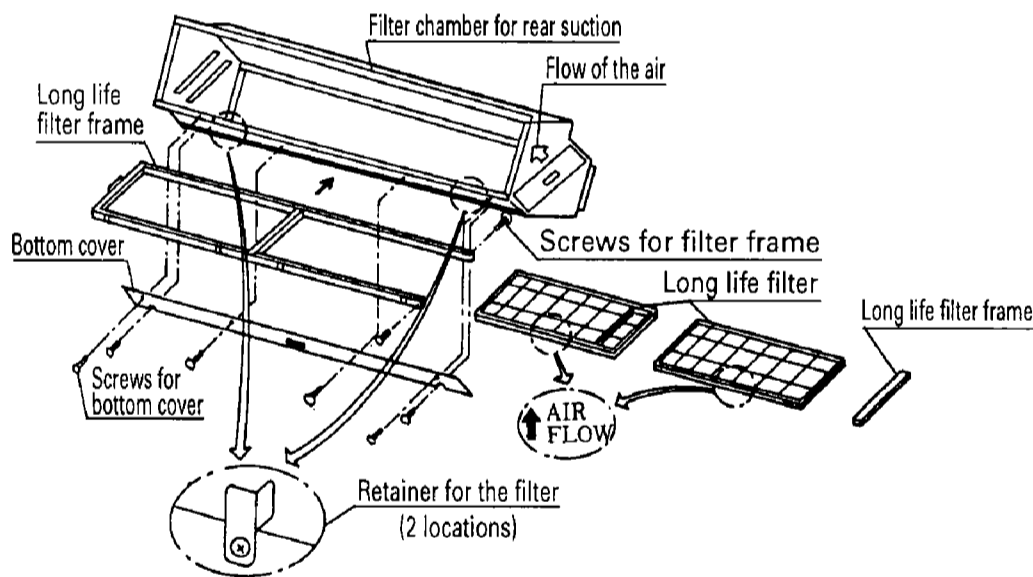
(In case installing from the bottom of the filter chamber)

- Remove the bottom cover.
- Remove the filter frame for long life filter from the filter chamber.
- Set the long life filter to the filter frame.

#### Caution

Be sure to set the arrow mark of the long life filter to the flow of the air.

- Insert the filter frame to the filter chamber.
- Attach the bottom cover.



### In case the high efficiency filter (optional kit) is used.

#### Installation of high efficiency filter

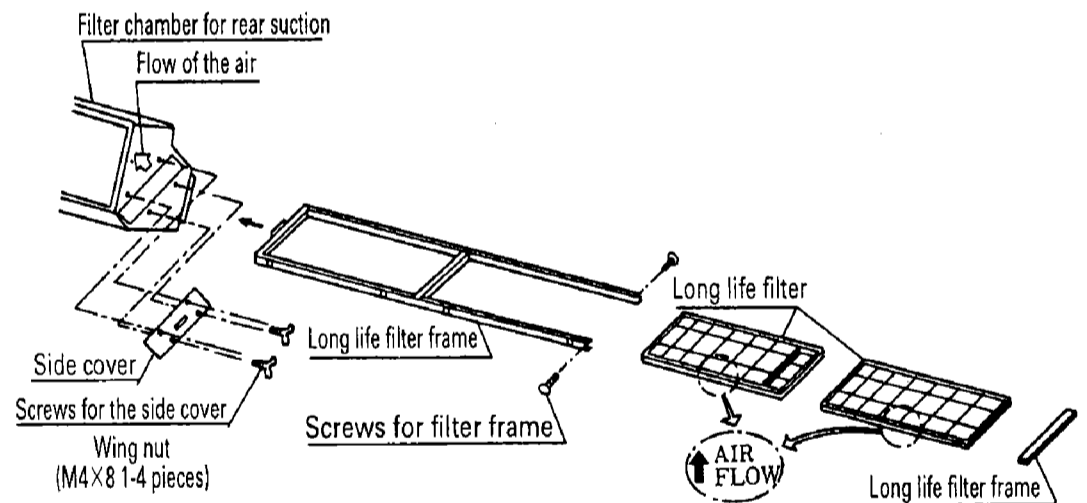
(In case installing from the bottom of the filter chamber)

- Remove the bottom cover.
- Set the high efficiency filter to the filter frame for long life filter.  
(Fix the filter with the retainer for the filter.)

#### Caution

Be sure to set the arrow mark on the high efficiency filter to the flow of the air. Be careful when you install the filter for model 60 and 125, because the filter size of right and left is different.

- Attach the bottom cover.



#### Installation of long life filter

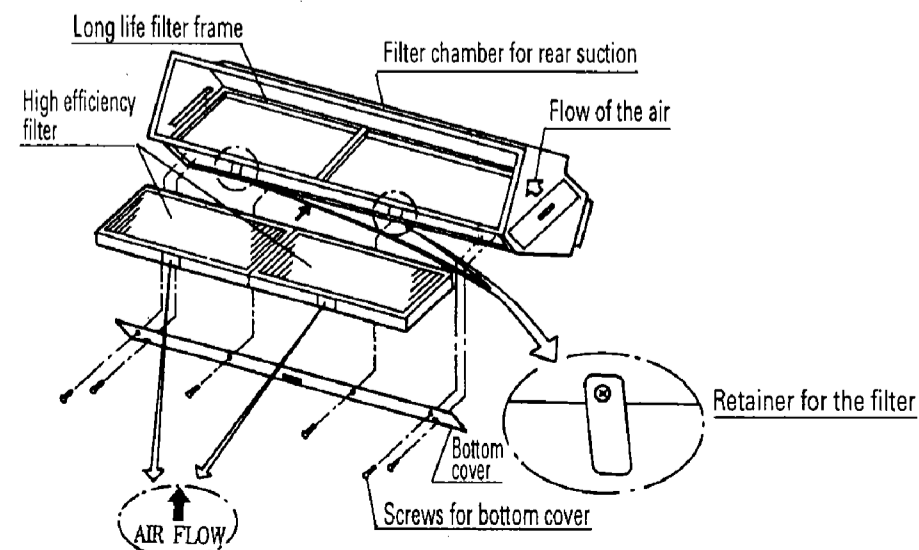
(In case installing from the side of the filter chamber)

- Remove the side cover.
- Remove the filter frame for long life filter from the filter chamber.
- Set the long life filter to the filter frame.

#### Caution

Be sure to set the arrow mark on the long life filter to the flow of air.

- Insert the filter frame to the filter chamber.
- Attach the side cover.



#### Installation of high efficiency filter

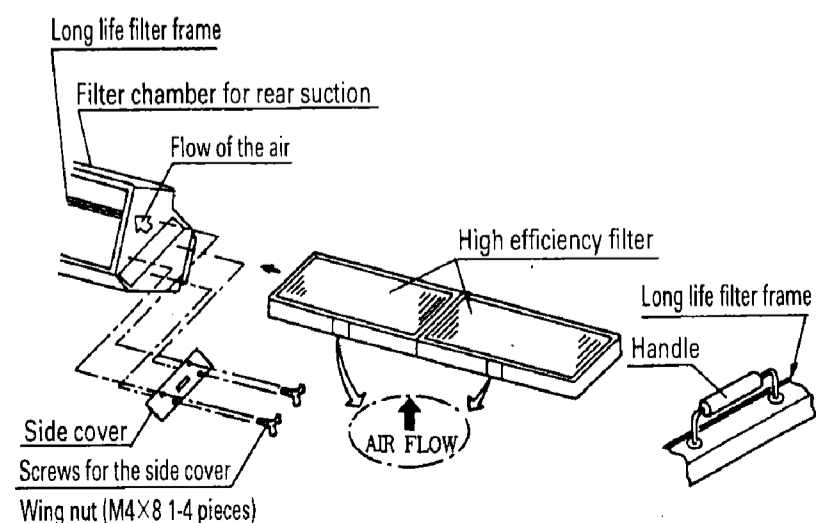
(In case installing from the side of the filter chamber)

- Remove the side cover.
- Set the high efficiency filter to the filter frame of long life filter.

#### Caution

Be sure to set the arrow mark on the high efficiency filter to the flow of air. Be careful when you install the filter for model 60 and 125, because the filter size of right and left is different.

- Attach the side cover.



# 10.7 Canvas duct – KSAJ25K56 · 80 · 160

## ● Specifications

Model \ Item		KSAJ25K56	KSAJ25K80	KSAJ25K160
Dimension (mm)	Width	700	1000	1400
	Depth	405	405	405
	Height	240	240	240
Canvas duct		Flame resistant		
Applicable model		Suction panel BYBS45D-W2	Suction panel BYBS71D-W2	Suction panel BYBS125D-W2

## 1. Contents of kit

Name	Quantity		
	KSAJ25K56	KSAJ25K80	KSAJ25K160
Canvas duct	1	1	1
Turn-buckle	4	4	4
Screws for canvas duct	4	4	4
Adjuster plate	4	4	4
Screws for adjuster	4	4	4
Installation manual	1	1	1

## 2. Tools required for the installation

Screw driver ⊕, Nipper

## 3. Installation

### (1) Installation of the canvas duct

- ① Set the 2 screws for canvas duct temporarily. (leave 30mm)
- ② Hook the canvas duct temporarily by shifting the canvas to the direction of the arrow. (Fig. 2)
- ③ Set the remaining 2 screws and fasten all of 4 screws until the thickness of sealing material becomes to 10~15mm.

### (2) Adjustment of the canvas duct

- ① Attach the suction panel. Refer to the installation manual of suction panel for details.

[In case the turn-buckle is used.]

- The canvas duct can be adjusted within the range of 160mm ~ 300mm. (Fig. 4)

a. Hook the one side of turn-buckle to the canvas duct and the other side to the chain and turn the turn-buckle without any gap between the suction panel and the ceiling.

(Extend the screws and set the turn-buckle facing the groove side to the top.)(Fig. 3)

b. Fasten the turn-buckle (to the clockwise) until there is no gap between the suction panel and the ceiling. Cut off the excess chain with nipper.

[ In case the adjuster plate is used.] (only when a half size suction panel is used at the same time.)

- The canvas duct can be adjusted within the range of 120mm ~ 160mm.

- The adjuster plate can not be used when the high efficiency filter is installed.

a. Remove the chain and set the same screws to the same place temporarily, and also set the 4 screws for the adjuster plate temporarily. (Fig. 5)

b. Set the four adjuster plate to each screws for the adjuster plate. (Fig. 6)(Refer to Fig. 7 for the direction of the adjuster plate.)

c. Turn the adjuster plate by lifting up the suction panel slightly to cover the gap between the suction plate and the ceiling. At that time be sure to set at the same notching position for all of the adjuster plate and the screws on the lower side. (Fig. 7)

d. Fasten all of the screws for fixing.

## ● Pressure loss of suction panel

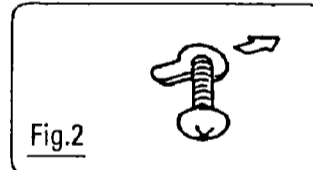
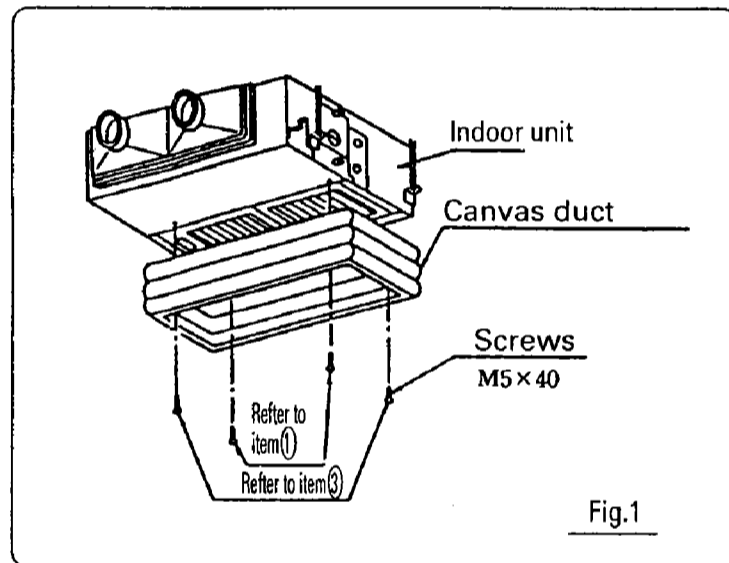
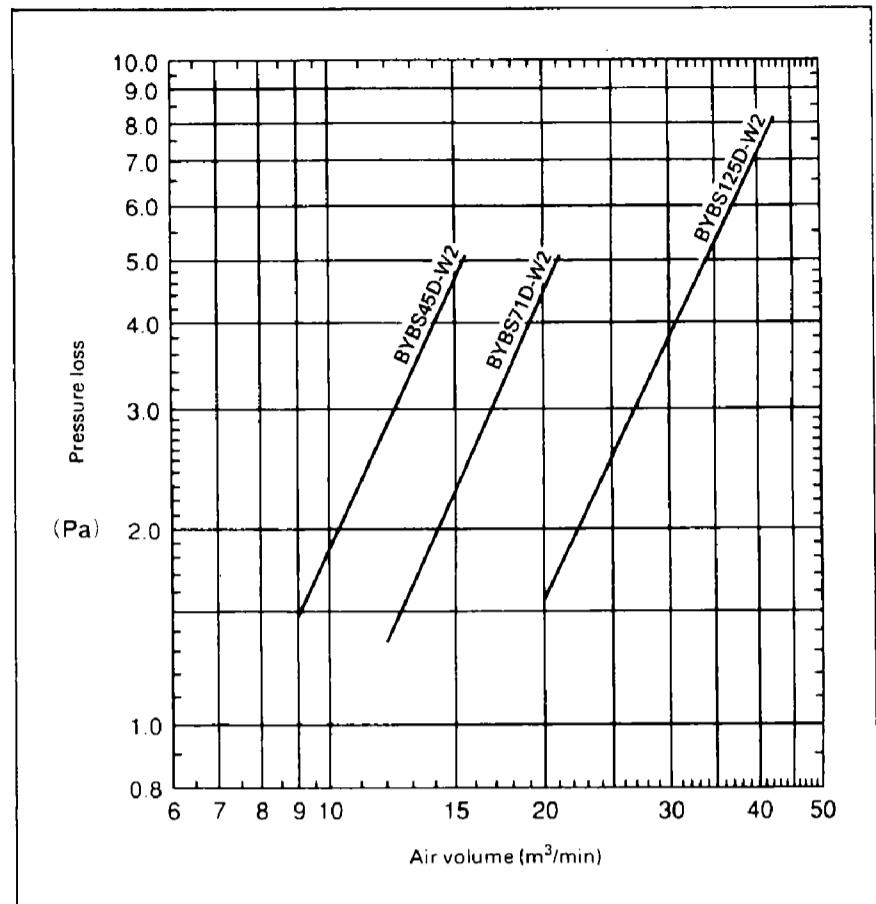


Fig.2

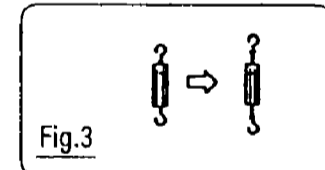


Fig.3

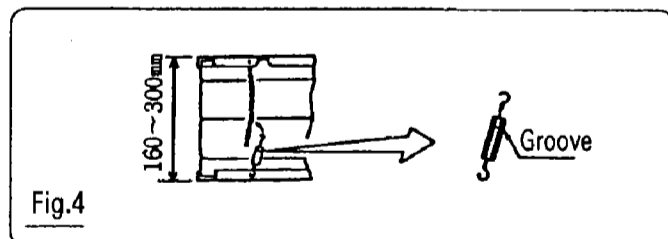


Fig.4

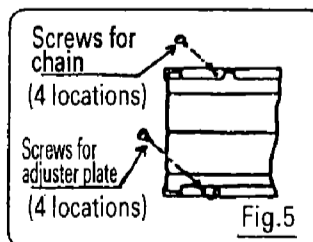


Fig.5

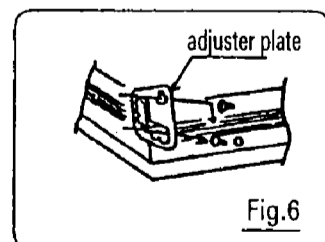


Fig.6

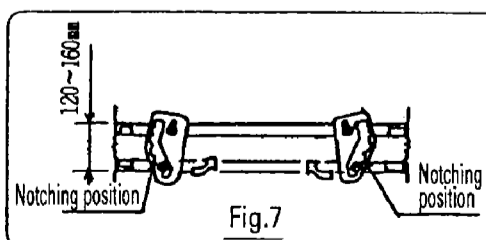


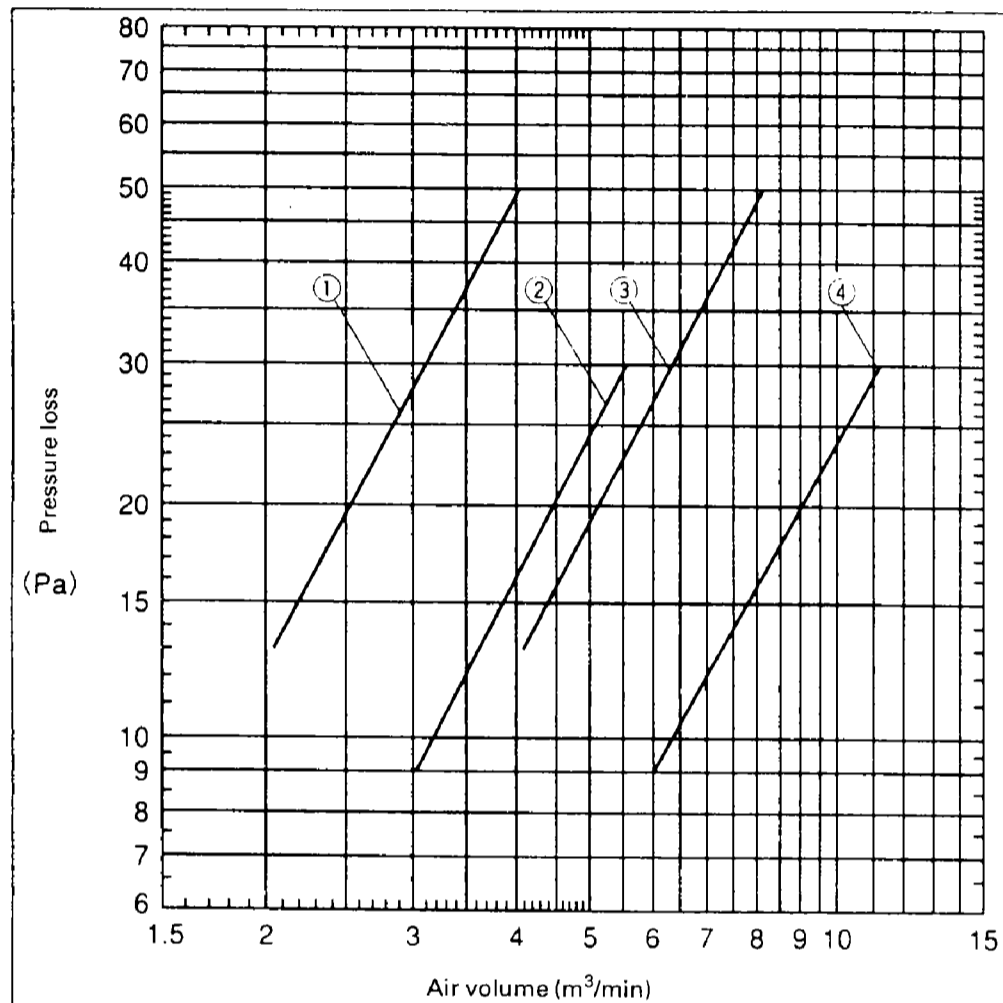
Fig.7

## 10.8 Air discharge unit-Discharge grille + Discharge chamber KDG90D4-1W · D5-1W · D7-1W · D9-1W KDG90B4-2 · B5-2 · B7-2 · B9-2

### ● Applicable model

Discharge grille	White	KDG90D4-1W	KDG90D5-1W	KDG90D7-1W	KDG90D9-1W
Discharge chamber		KDG90B4-2	KDG90B5-2	KDG90B7-2	KDG90B9-2
Size of Duct connection		$\phi$ 150		$\phi$ 200	
Applicable model		For indoor unit 35F~45F, 100F	For indoor unit 60F~71F, 125F	For indoor unit 35F~45F, 100F	For indoor unit 60F~71F, 125F

### ● Pressure loss of Discharge grille and Discharge chamber



No.	Model	No.	Model
①	KDG90D4-1+KDG90B4-2	③	KDG90D7-1+KDG90B7-2
②	KDG90D5-1+KDG90B5-2	④	KDG90D9-1+KDG90B9-2

Note: Refer to the followings for the dimension of discharge grille and discharge chamber.

### ● Contents of kit

Prior to installation check whether you have the complete kit parts as shown below including the installation manual.

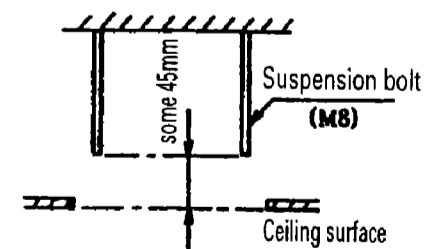
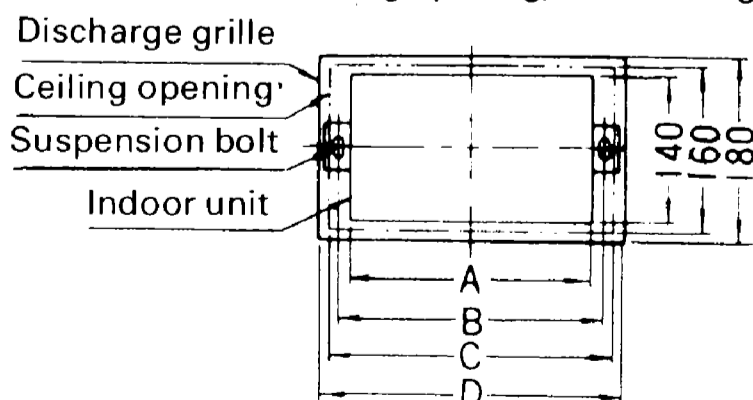
Name	Discharge chamber	Screws for Discharge grille	Sealing pad	Discharge grille	Installation manual
Shape				 吹出口ユニットのみ (KDG)	
Quantity	1 piece	4 pieces	4 pieces	1 piece	1 piece

### ① Selection of location for installation

- Be sure to consider the distribution of the temperature when you install the discharge chamber. When the discharge chamber is installed close to the wall, it may cause the condensation on the wall during the cooling.

### ② Preparation for installation

- Location of the ceiling opening, the discharge unit and the suspension bolts.



Discharge unit	Discharge chamber	A	B	C	D
KDGS90D4-W	KDG90B4-2	235	260	285	305
KDGS90D5-W	KDG90B5-2	320	345	370	390
KDGS90D7-W	KDG90B7-2	420	445	470	490
KDGS90D9-W	KDG90B9-2	590	615	640	660

### ③ Installation of discharge unit

#### (1) Installation of discharge chamber

- Suspend the discharge chamber by the suspension bolts. Be sure to fix securely with nut and washer from top and bottom side of the suspension bracket.
- Adjust the level of the discharge chamber at 35~40mm from the ceiling surface.

#### (2) Installation of discharge grille

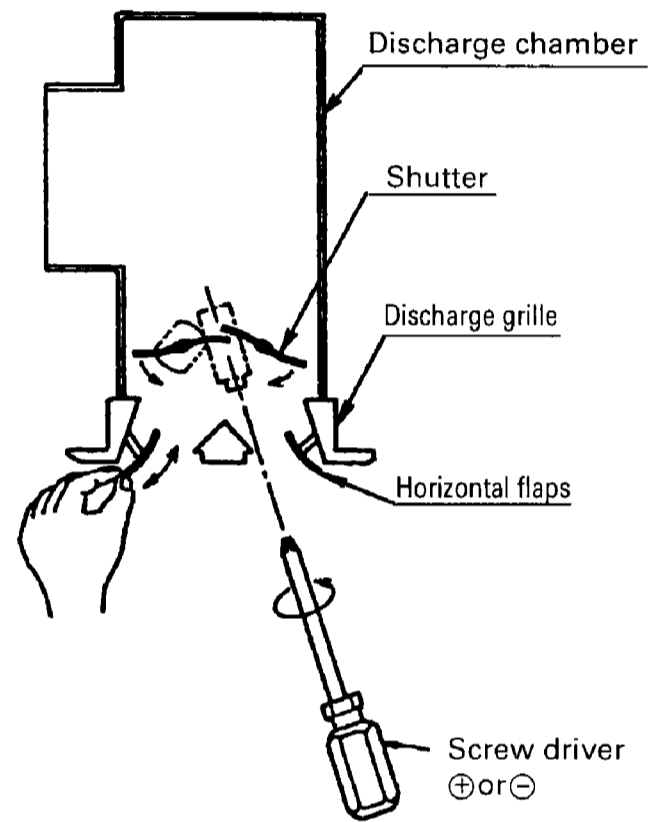
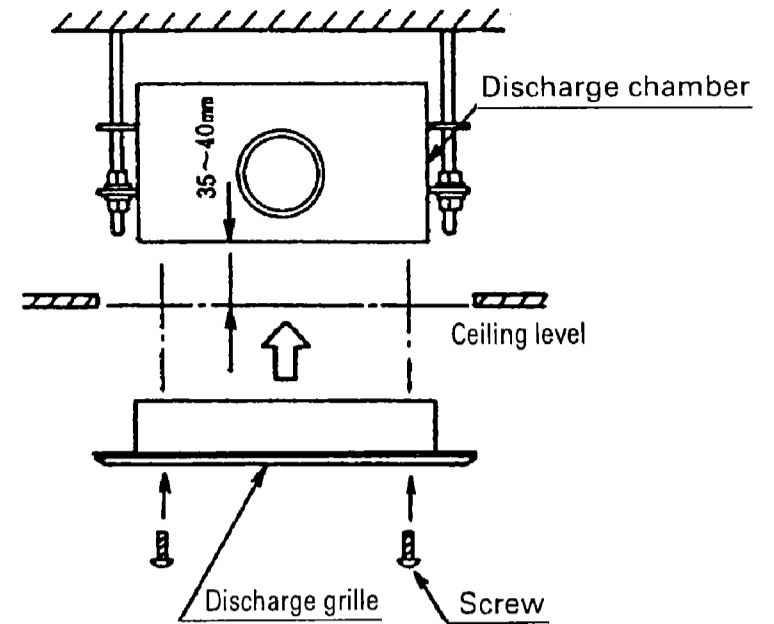
- Set the discharge grille to the discharge chamber with the screws. (4 pieces)
- If it is required to adjust the gap between the discharge chamber and the discharge grille, attach the sealing pad to the discharge chamber so as no gap with the discharge grille.

#### (3) Adjust the air flow

- Adjust the air flow of each discharge chamber at the same level within the operative range with screw driver ⊕ or ⊖. If the air flow of each discharge chamber is out of operating range or different, it may cause the abnormal noise or the condensation problem.
- Never operate at the shutter at "full close".

#### (4) Adjust the horizontal

- Adjust the horizontal flaps by hand to change the air direction.

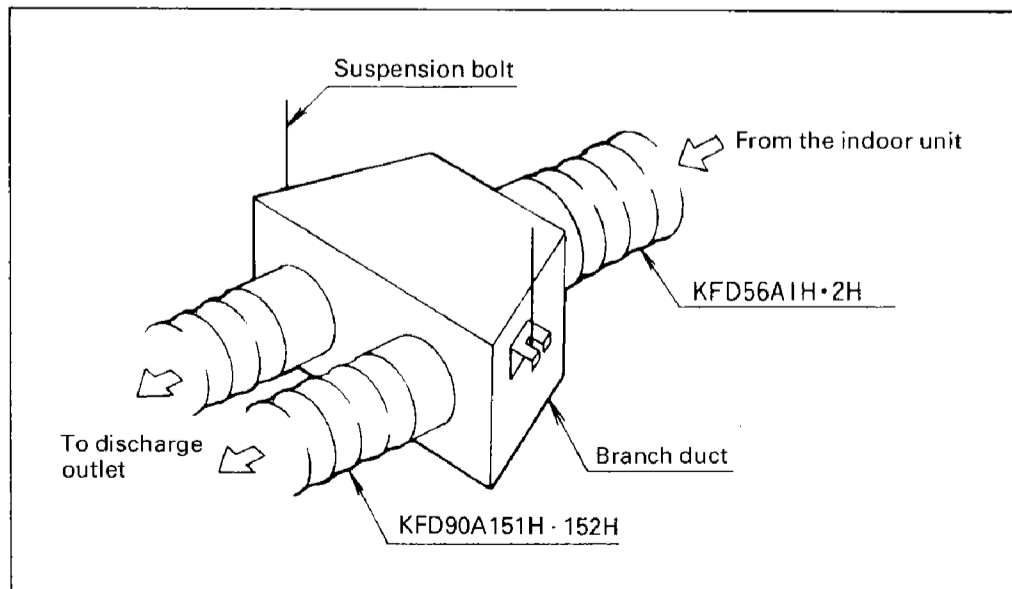


## 10.9 Branch duct — KHA90B1

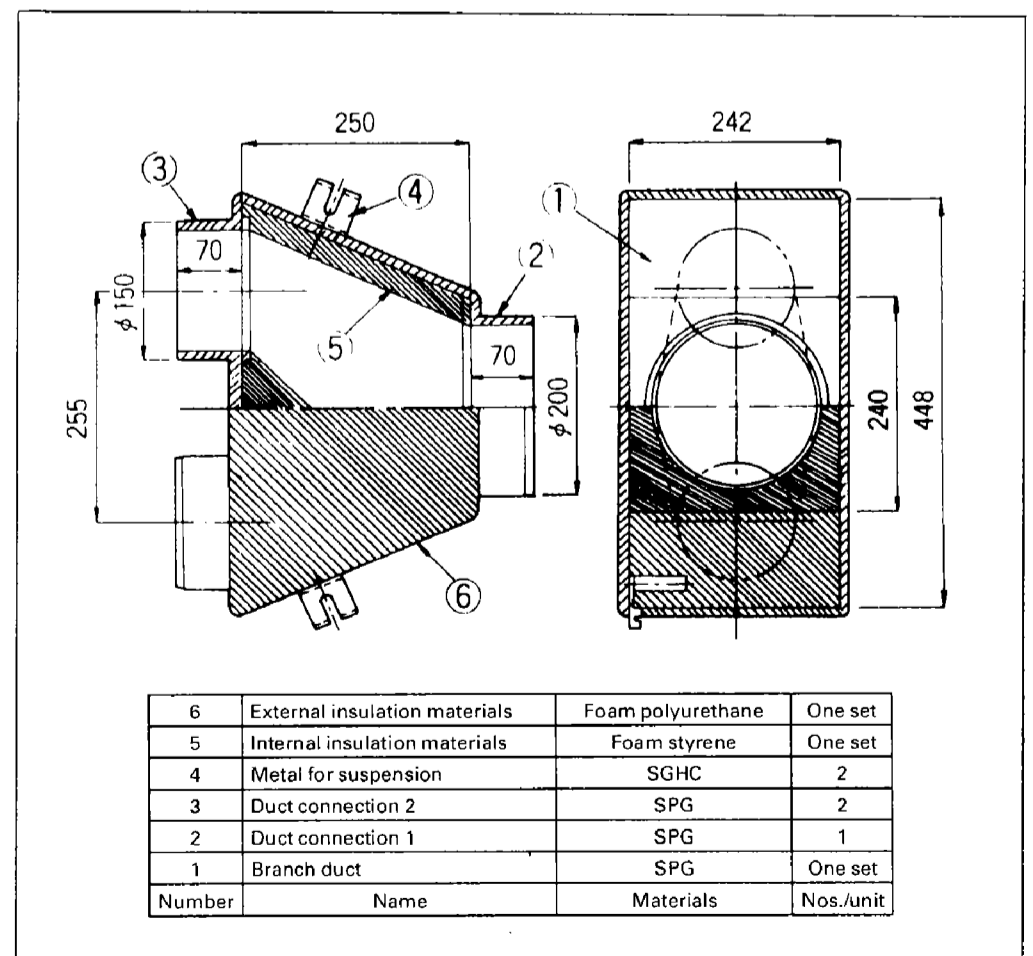
### ● Specification

Item	Kit name	KHA90B-1
Inlet connection size×Nos.		φ 200×1
Outlet connection size×Nos.		φ 150×2
External insulation materials		Foam polyurethane
Internal insulation materials		Foam styrene

### ● Installation

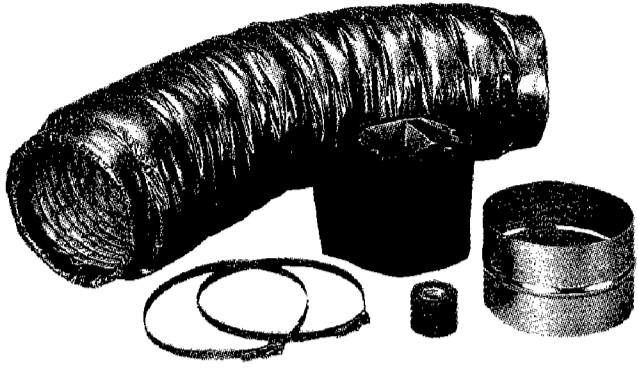


### ● Dimensions





# 10.10 Flexible duct – KFD90A151H·152H KFD56A1H·2H



Flexible duct  
Joint  
Clamp band (2 pieces)  
Insulating materials  
Duct tape  
KFD56A1H

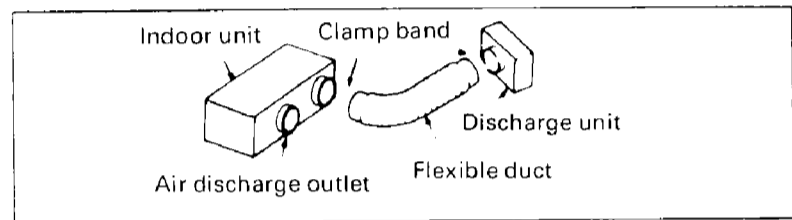
### ● Specifications

Item		Kit name			
		KFD90A151H	KFD90A152H	KFD56A1H	KFD56A2H
Dimensions	Length (m)	1	2	1	2
	Maximum diameter	φ 208		φ 258	
	Size of connection	φ 155(Inner size)		φ 205(Inner size)	
Working temperature		-10~+70C°			
Applicable model		KDG90B4-2 · B5-2 KHA90B-1 · KDG89A411		KDG90B7-2 · B9-2 KDG89A411	

### ● Features

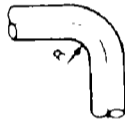
1. It can be bent flexibly.
2. It's already insulated, and it can easily be installed by the clamp band attached.
3. It can be extended in any length by connecting the number of flexible ducts by joints.

### ● Example of installation

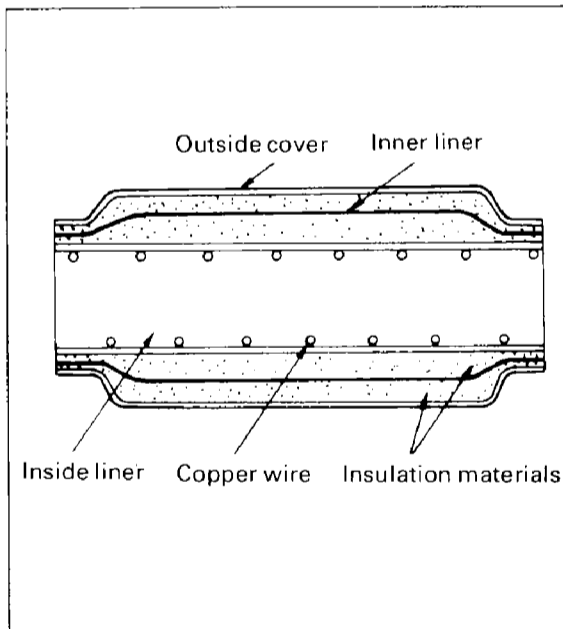


### ● Cautions

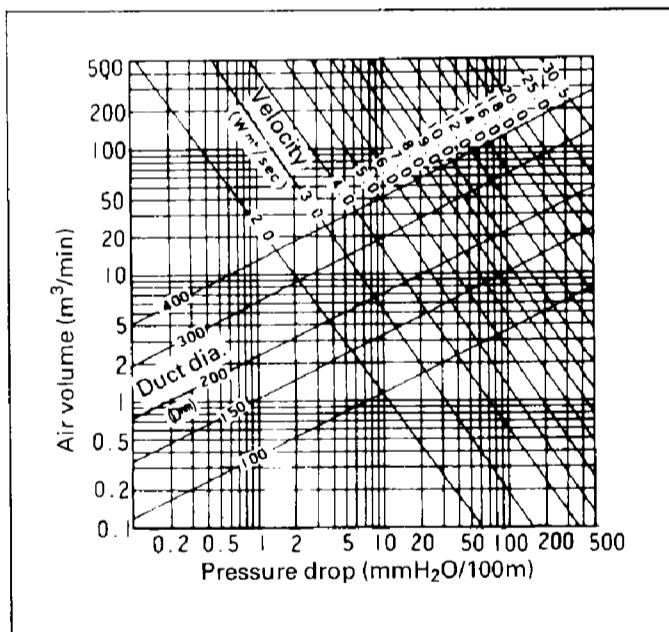
1. In order to minimize the pressure loss, make a large radius when you bend the flexible duct.
2. Minimum bending radius  
φ 150: 15cm  
φ 200: 30cm



### ● Construction



### ● Pressure drop of flexible duct



## 10.11 Blind board – KBBJ25K56 · 80 · 160

### ● Specifications

Item		Kit name	KBBJ25K56	KBBJ25K80	KBBJ25K160
Dimensions (mm)	Width		685	985	1385
	Depth		404		
	Thickness		10		
Materials			Galvanized steel plate		
Applicable model			For indoor unit 35F~45F	For indoor unit 60F~71F	For indoor unit 100F~125F

### ● Application

Blind the bottom suction when the unit is installed with the rear suction.

#### 1. Contents of kit

Name	Quantity		
	KBBJ25K56	KBBJ25K80	KBBJ25K160
Blind board	1	1	1
Screws	4	6	6
Installation manual	1	1	1

#### 2. Tools required for the installation

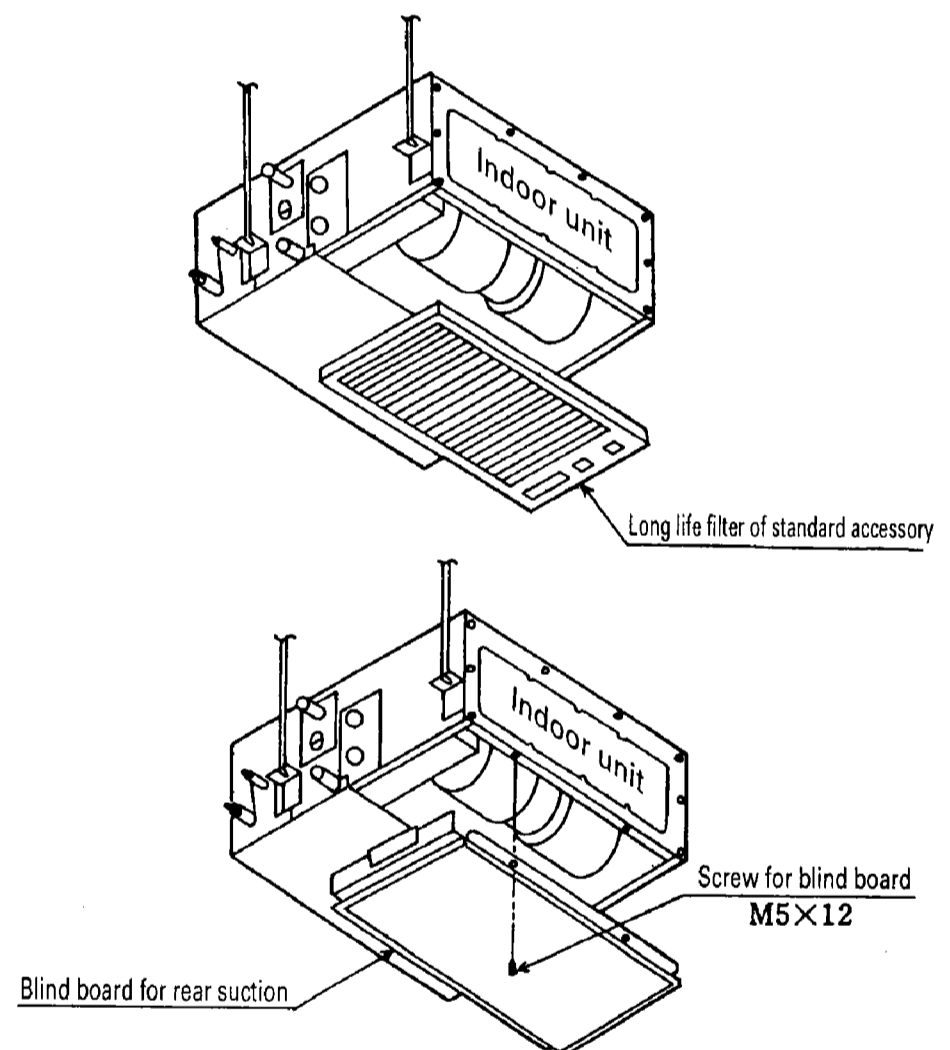
Screw driver ⊕

### 3. Installation procedure

- 1) Remove the long life filter from the indoor unit
- 2) Attach the blind board to the indoor unit

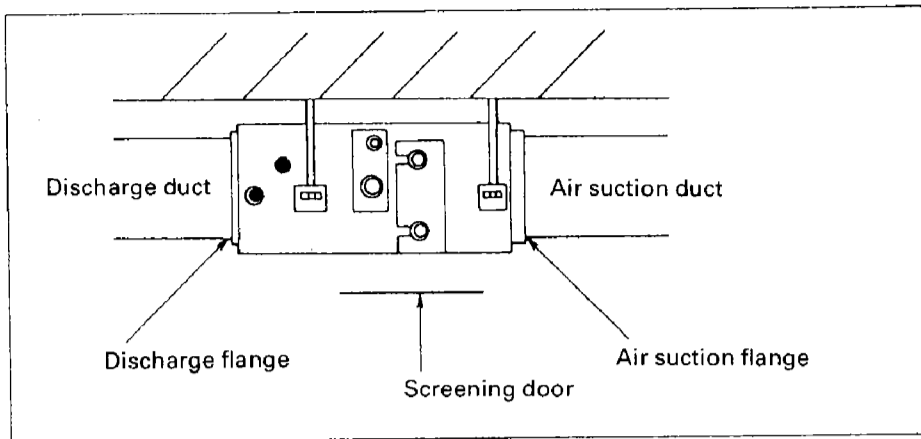
### 4. Cautions for the installation

- Follow the instruction in this manual and install properly.
- Fasten the screws tightly so as no gap between the indoor unit and the blind plate.



## 10.12 Flange for suction – KDJ2507K56 · 80 · 160

### ● Example of installation



### ● Specifications

Item	Kit name		Flange for suction		
			KDJ2507K56	KDJ2507K80	KDJ2507K160
Dimensions (mm)	Width		677	977	1377
	Height		278		
	Depth		25		
Size of connecting duct (mm)	Width		627	927	1327
	Length		228		
Materials	Galvanized steel plate				
Applicable model			For indoor unit 35F~45F	For indoor unit 60F~71F	For indoor unit 100F~125F

### 1. Contents of kit

Name	Quantity		
	KDJ2507K56	KDJ2507K80	KDJ2507K160
Flange for suction	1	1	1
screws	14	18	24
Installation manual	1	1	1

Note: This kit requires the shielding plate (optional) for the suction port at the back of the unit.

### 2. Tools required for the installation

Screw driver ⊕

Nipper

Drill (6mm  $\phi$ )

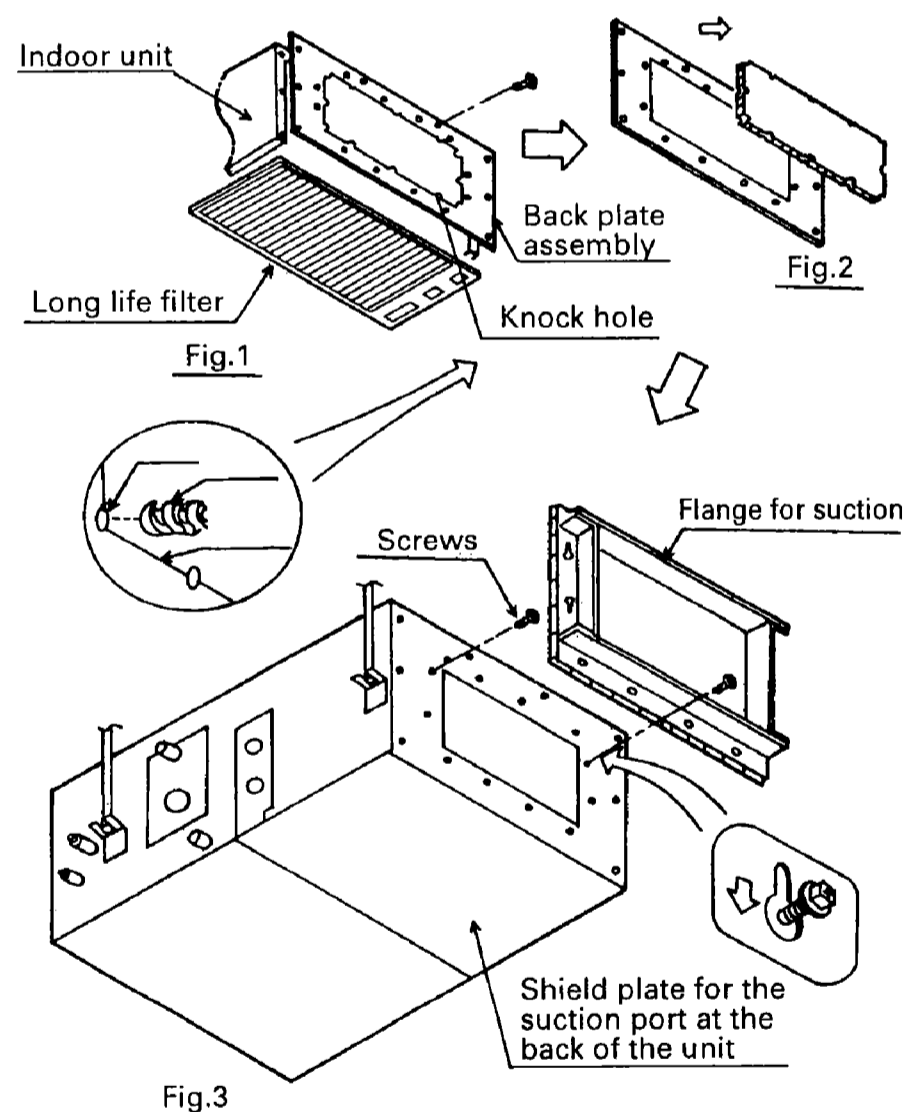
Cutting knife

### 3. Installation of the flange for suction

- Remove the long life filter at the bottom of the unit. (Fig.1)
- Remove the back plate assembly. (Fig.1)
- Drill the hole of the 6mm  $\phi$  at the center of the knock hole on the back plate assembly.
- Cut off the sound insulation attached on the back plate by cutting knife. (Fig.2)
- Attach the back plate assembly to the indoor unit. (Fig.3)
- Attach the blind board (Optional kit) to the bottom of the indoor unit. (Fig.3)
  - Set the 2 screws to the indoor unit and fasten temporarily. (Leave 5mm)
  - Hook the flange for suction temporarily and fasten all the screws.

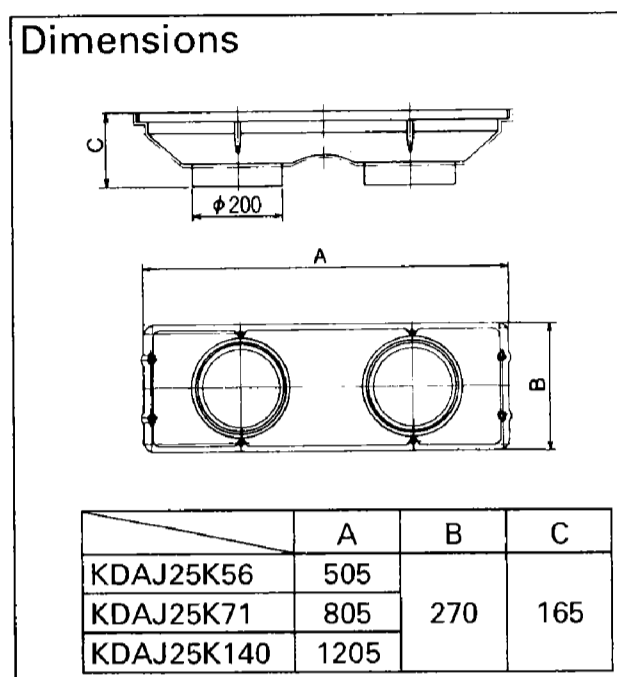
### 4. Cautions for installation

- Follow the instruction in this manual and install properly.
- Fasten tightly so as no gap between the indoor unit and the flange for suction (with gasket).



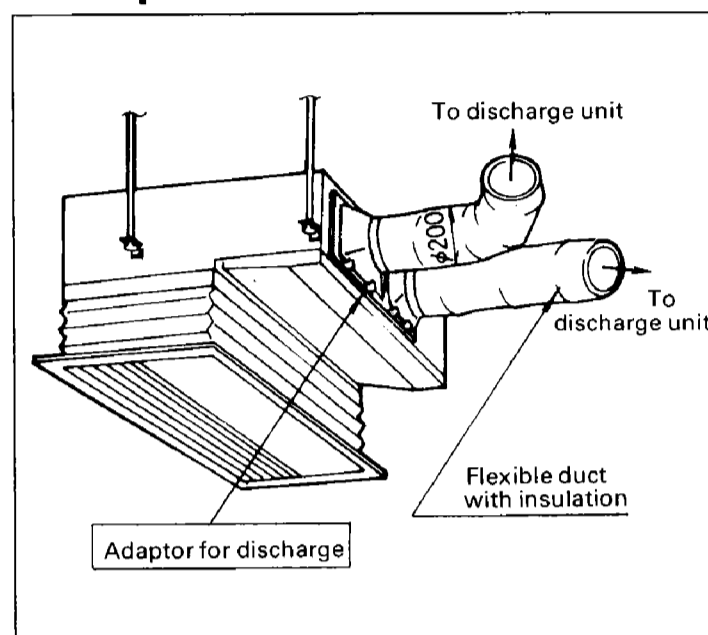
## 10.13 Adaptor for discharge – KDAJ25K56 · 71 · 140

Item	Kit name	KDAJ25K56	KDAJ25K71	KDAJ25K140
Applicable models		FH(Y)B35 · 45F	FHYB71F	FHYB100 · 125F
Connection Dia ( φ mm)		φ 200×2 port		φ 200×4 port
Materials		Plastic		



Note: Use with optional flexible duct.

### ● Example of installation



### 1. Contents of kit

Name	Quantity		
	KDAJ25K56	KDAJ25K71	KDAJ25K140
Adapter for discharge	1	1	1
Installation manual	1	1	1
screws	8	8	12

### 2. Tools required for the installation

Screw driver ⊕

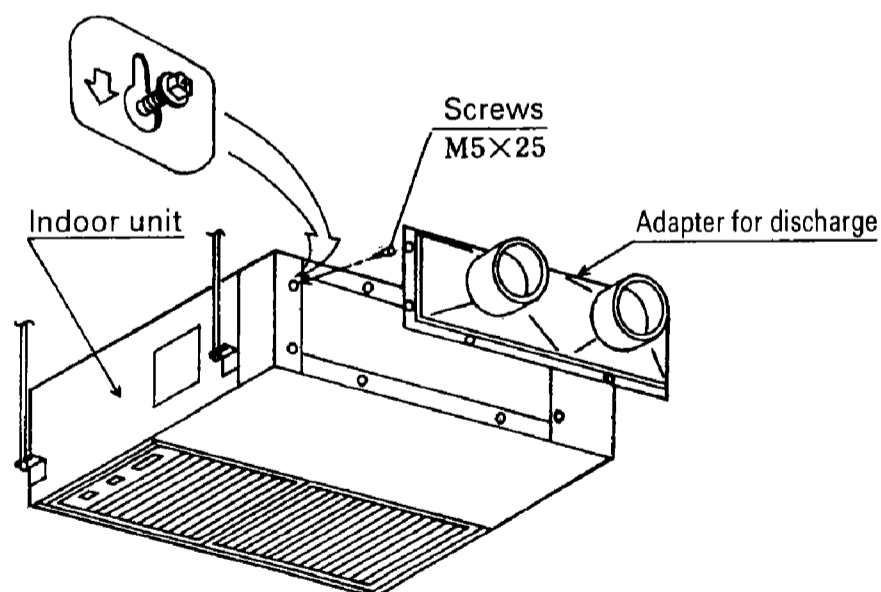
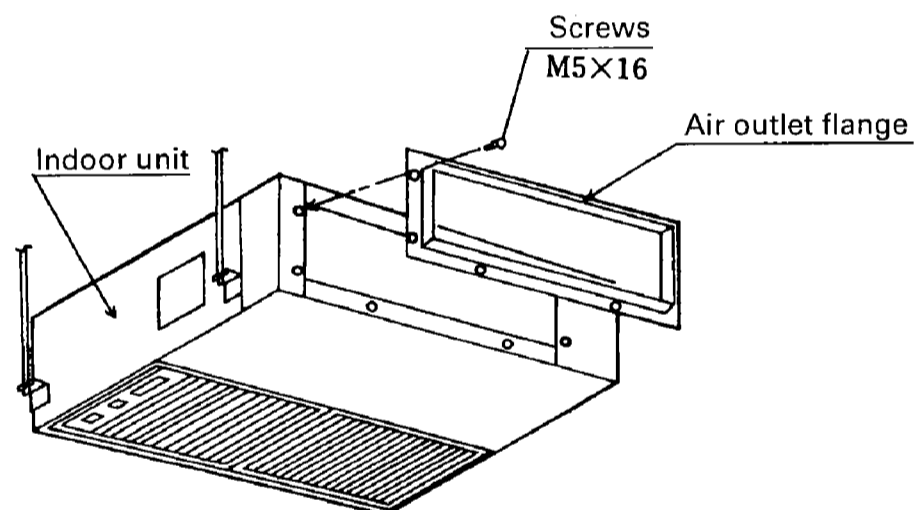
### 3. Installation of the adaptor for discharge

- 1) Remove the air outlet flange from the indoor unit.
- 2) Attach the adaptor for discharge to the indoor unit.

- ① Set the screws at 2 location of the indoor unit and fasten temporarily. (leave 20mm)
- ② Hook the adaptor for discharge temporarily on the screws and fasten all the screws.

### 4. Cautions for the installation

Fasten the screws tightly so as no gap between the indoor unit and the adaptor for discharge.



## 11 Ceiling suspended type [FH(Y)]

### 11.1 Drain pump kit – KDUJ5F50 · 80 · 160 (For 60Hz only)

#### 1. Specifications

Kit	KDUJ5F50	KDUJ5F80	KDUJ5F160
Applicable air conditioner	FH(Y)J35F FH(Y)J45F	FH(Y)J63F FH(Y)J71F	FH(Y)J100F FH(Y)J125F
Power supply	Single phase 220V 60Hz (from indoor unit pc board)		
Power consumption (w)	12		
Drain pump height	From the drain outlet center 750 mm		
Drain outlet	VP 25 (External dia. 32, internal dia. 25)		
Safety device	Float switch		
Weight (kg)	3.0	3.0	3.5

#### [Accessories]

Name	Quantities per unit		
	KDUJ5F50	KDUJ5F80	KDUJ5F160
Drain pump assy	1	1	1
Internal drain hose	1	1	1
External drain hose	1	1	1
Clamp metal (small)	2	2	2
Clamp metal (large)	1	1	1
Mounting screw	M4×3	M4×3	M4×3
Clamp (short)	10	10	8
Wire harness	1	1	1
Insulation for fitting (large)	1	1	1
L-shape hose (Elbow)	1	1	1
Thermal insulation	5	5	5
Gas side attached pipe	1	1	1
Liquid side attached pipe	1	1	1
Insulation for fitting (medium)	1	1	1
Insulation for fitting (small)	1	1	1
Blind plate	1	1	1
Drain pump kit mounting plate	1	1	1

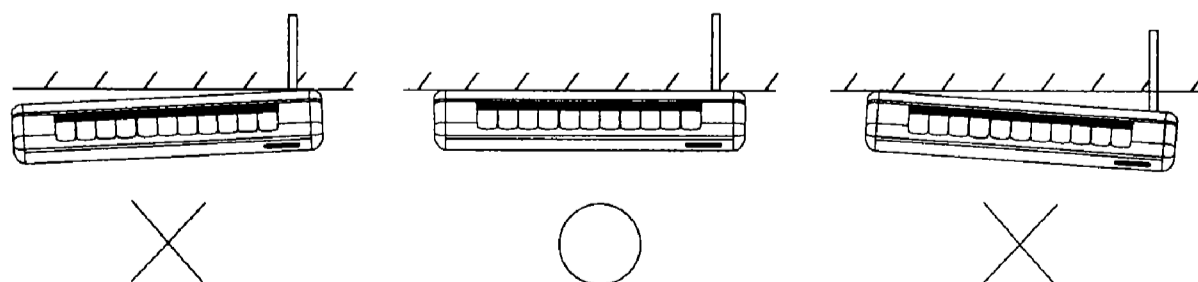
#### 2. Tools required for the installation work

Screwdrivers (⊕, ⊖) nippers, cutters, saw (for cutting the accompanying external drain hose)

#### 3. Installation precautions

Be sure to install the indoor unit levelled.

- If slanted installation it may cause water leakage and abnormal stop.



## 4. Before setting up the air conditioner

The drain pump kit is set up after the air conditioner has been mounted in position. But take the following steps before setting up the air conditioner.

### 4-1. Installation space

The kit requires only the set-up/servicing space of the indoor unit. Refer to the installation manual provided with the indoor unit.

### 4-2. Make the following preparations.

1) Make a  $300 \times 300$  mm opening in the ceiling by using the paper pattern for installation of the air conditioner. This opening is to pass the pipe along. See Fig. 1. (Make sure that with the air conditioner in place, the opening is invisible from below.)

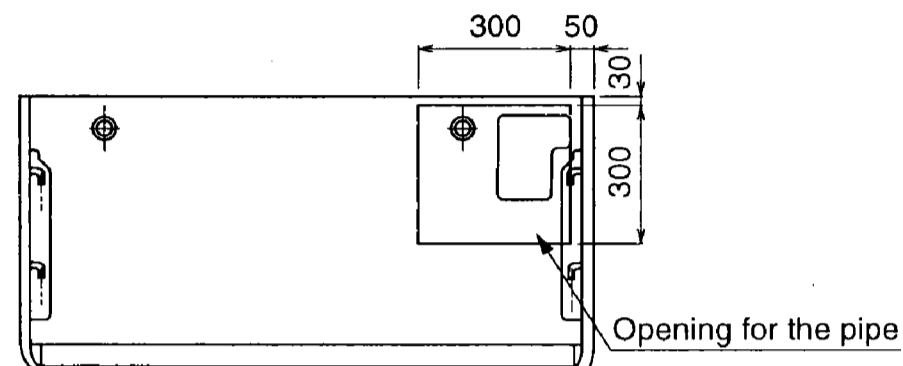


Fig. 1

- 2) (1) Referring to the installation manual of the air conditioner, remove the side panel, blind plate, suction grille and air filter.
- (2) Remove the mounting plate and steel wire off the air conditioner. (Fig. 2(a))
- (3) Fix the attached drain pump kit mounting plate. Pass the lead wires (swing motor lead wire, etc.) through the plates hole. (Fig. 2(b))

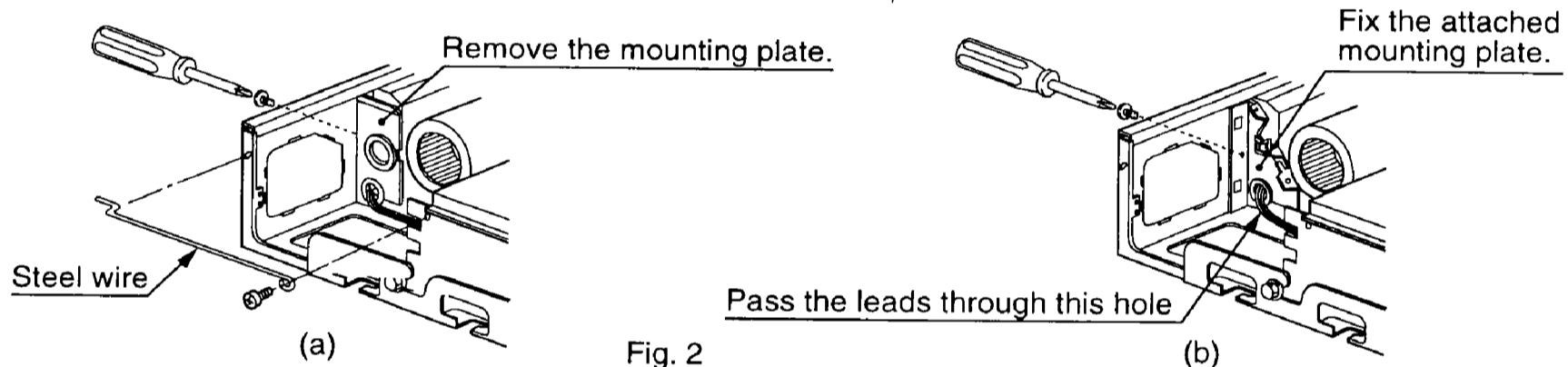


Fig. 2

3) Connect the attached refrigerant pipe to the local refrigerant pipe. Wrap the insulation for fitting of the air conditioner around the connection of these pipes. Secure the tube with the clamps. (Fig. 3)

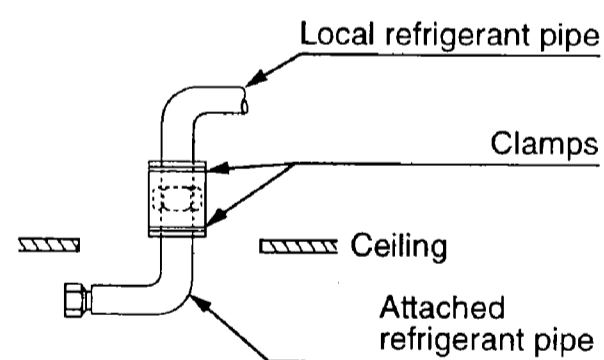


Fig. 3

4) Make preparations for the piping behind the ceiling.

- (1) Adjust the length of the attached drain pipe according to the head required in the ceiling. (Fig. 4) (For the adjustable drain pump height range, see the table below.)
- (2) Connect the pipes together with the attached elbow. (Fig. 5)

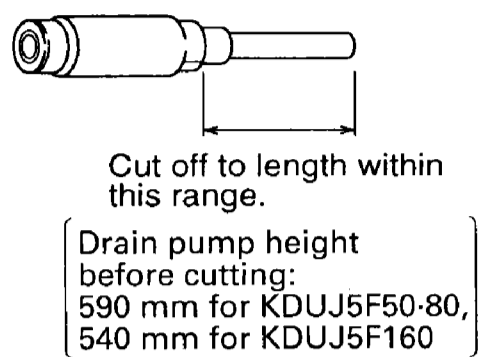


Fig. 4

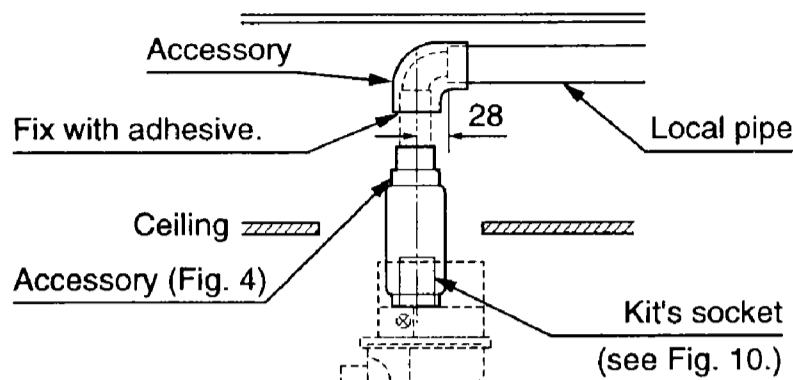


Fig. 5

The heights of the local pipe above the air conditioners top are as listed below.

Kit	Drain pump height above air conditioners top	Adjustable drain pump height range by cutting the attached pipe (Fig. 4)
KDUJ5F50-80	Max. 590 mm	190~590 mm
KDUJ5F160	Max. 540 mm	140~540 mm

5) Wrap the attached insulation for fitting, which was cut to length, around the external drain hose. (Fig. 6)

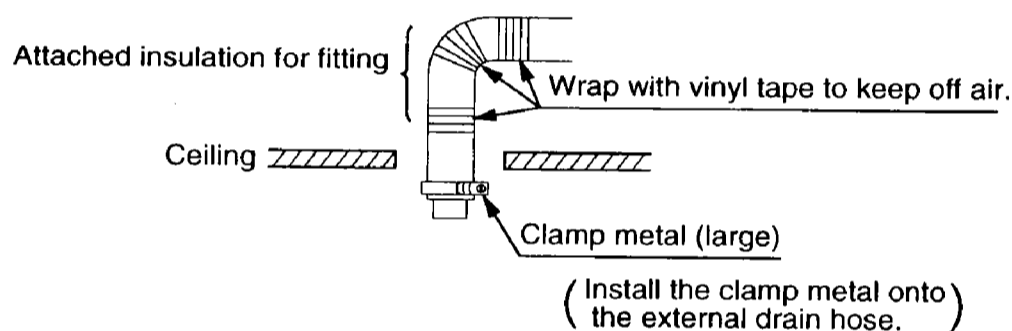


Fig. 6

- Notes)
1. Keep the local drain pipe short and sloping downwards at a gradient of 1/25 - 1/100 to prevent air pockets from forming.
  2. Be sure to provide thermal insulation around the drain pipe running behind the ceiling.
  3. Be sure to lay and fix the attached pipe on the support behind the ceiling.
  4. Be sure to apply adhesive to the connection between the attached pipe and the local drain pipe behind the ceiling.

## 5. Setting up the drain pump kit

After installing the air conditioner, set up the drain pump kit in the following procedure.

1. Connect the refrigerant pipe to the air conditioner.

- (1) Connect the liquid pipe and the gas side attached pipe to the air conditioner. (Fig. 7(a))
- (2) Wrap the attached insulation for fitting first and then the attached sealing pad. For the gas side attached pipe, wrap the sealing of the air conditioner around the insulation for fitting at the pipe connection. (Fig. 7(b))

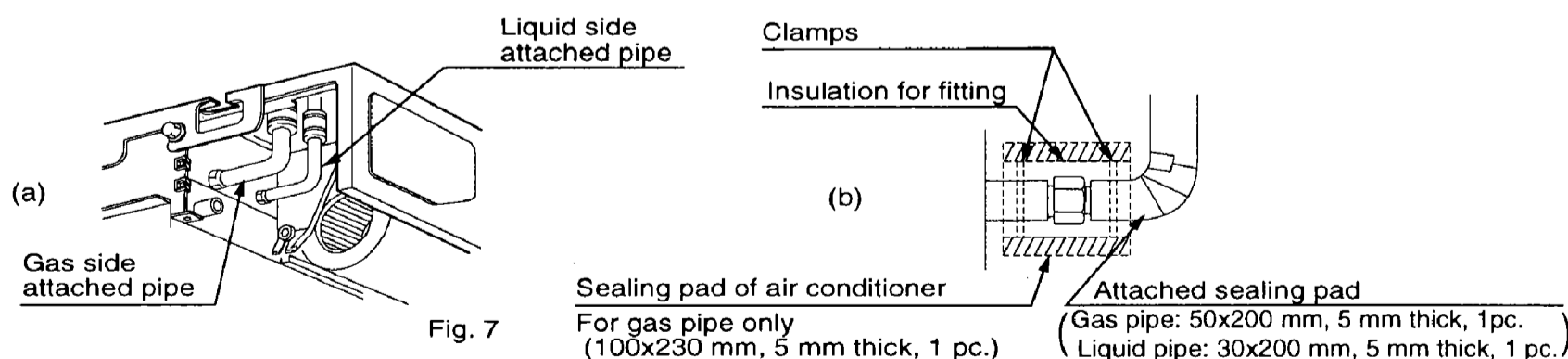


Fig. 7

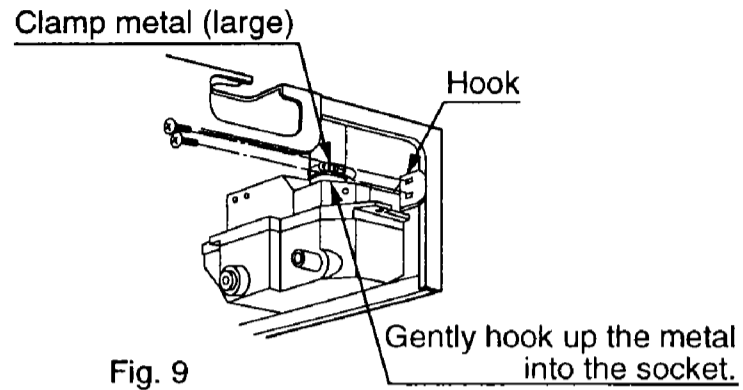
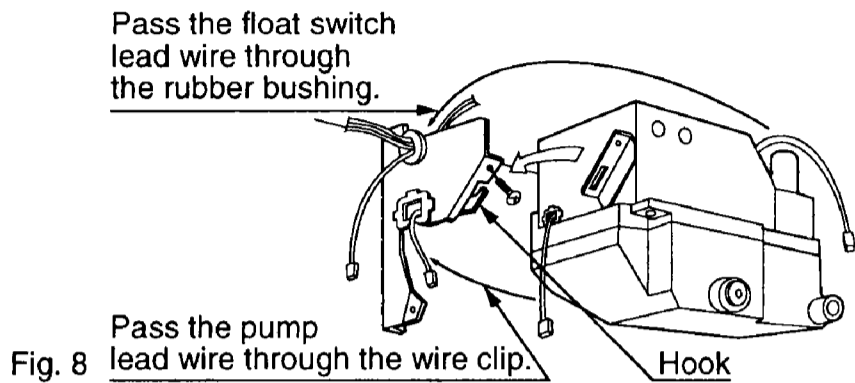
2. Set up the drain pump kit on the air conditioner.

(1) Let the float switch lead wire (black) hang in front.

Install the clamp metal (large) onto the external drain hose, and gently hook the metal to the kit drain socket. (Figs. 8 and 9)

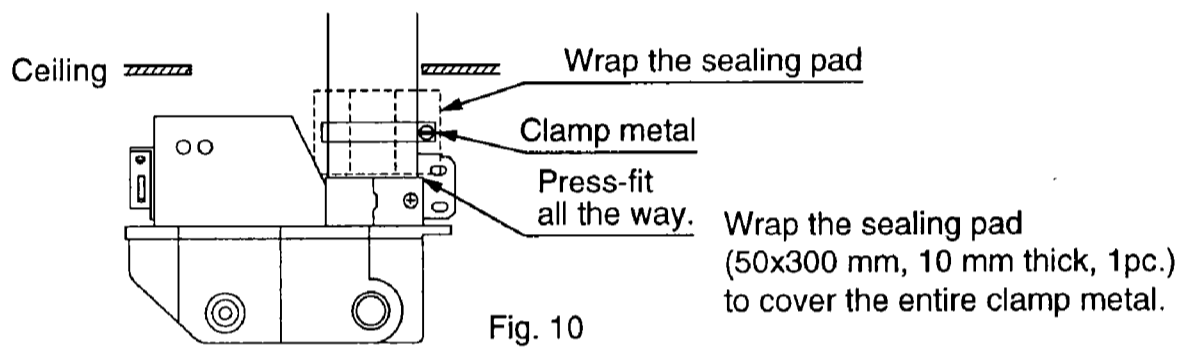
(2) Hook the kit on the air conditioner's side panel and mounting plate. Screw down the kit. (Figs. 8 and 9)

(3) Pass the float switch lead wire through the rubber bushing. Pass the pump lead wire through the wire clip. (Fig. 8)

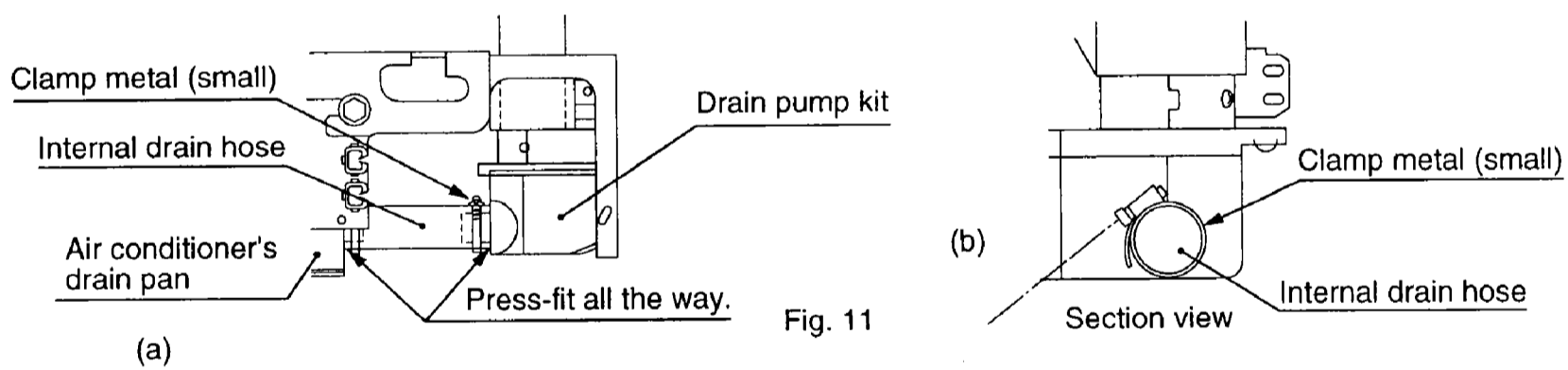


3. (1) Insert the external drain hose all the way into the kit drain socket. Tighten up the hose with the clamp metal.

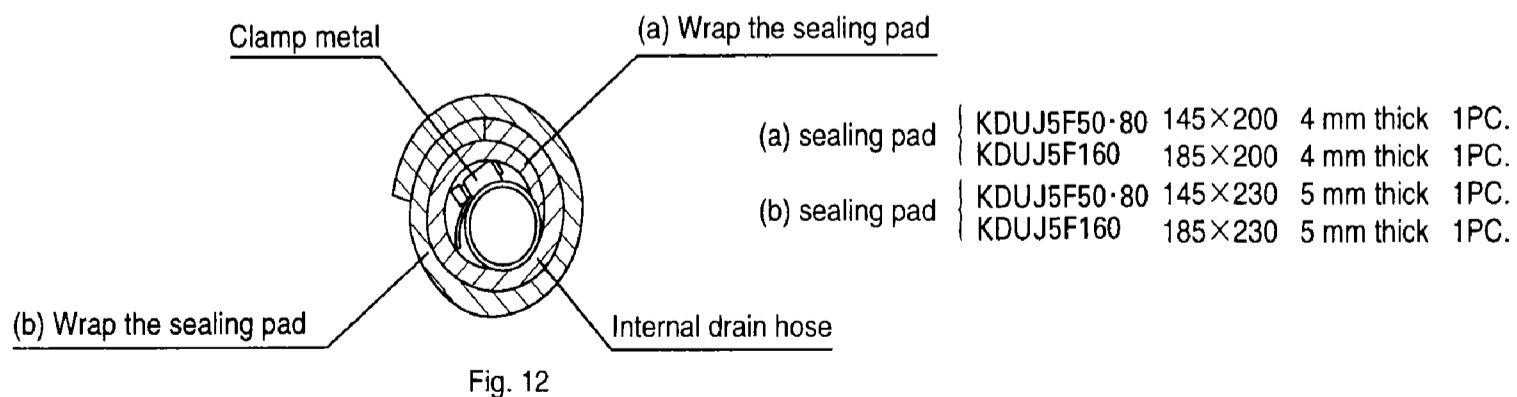
(2) Apply the attached sealing pad to the connection. (Fig. 10)



4. Connect the attached internal drain hose tightly and fully between the air conditioner's drain pan and the kit's drain pan. Tighten up the clamp metal (small). (Fig. 11(a)) Position the clamp metal as shown in Fig. 11(b).



5. Apply the attached sealing pad around the internal drain hose. Cover the entire clamp metal of the drain hose. (Fig. 12)





6. Lay and dress the lead wires coming from the kit in the following manner. (Remove the electric parts box for easier work.) Before starting this work, be sure to turn off the power.

(1) Remove the electric parts box lid and the steel wire of the air conditioner.

(2) Connect the attached wire harness (red) to the pump lead wire first and then to X25A (white connector) on the PC board.

Draw the connector out of X8A (green connector) and connect the float switch lead wire instead. (Fig. 13)

If the lead wire is too long, bind its excess part to the other lead wires with the clamp. Using clamps, bundle the lead wires with those along the same route.

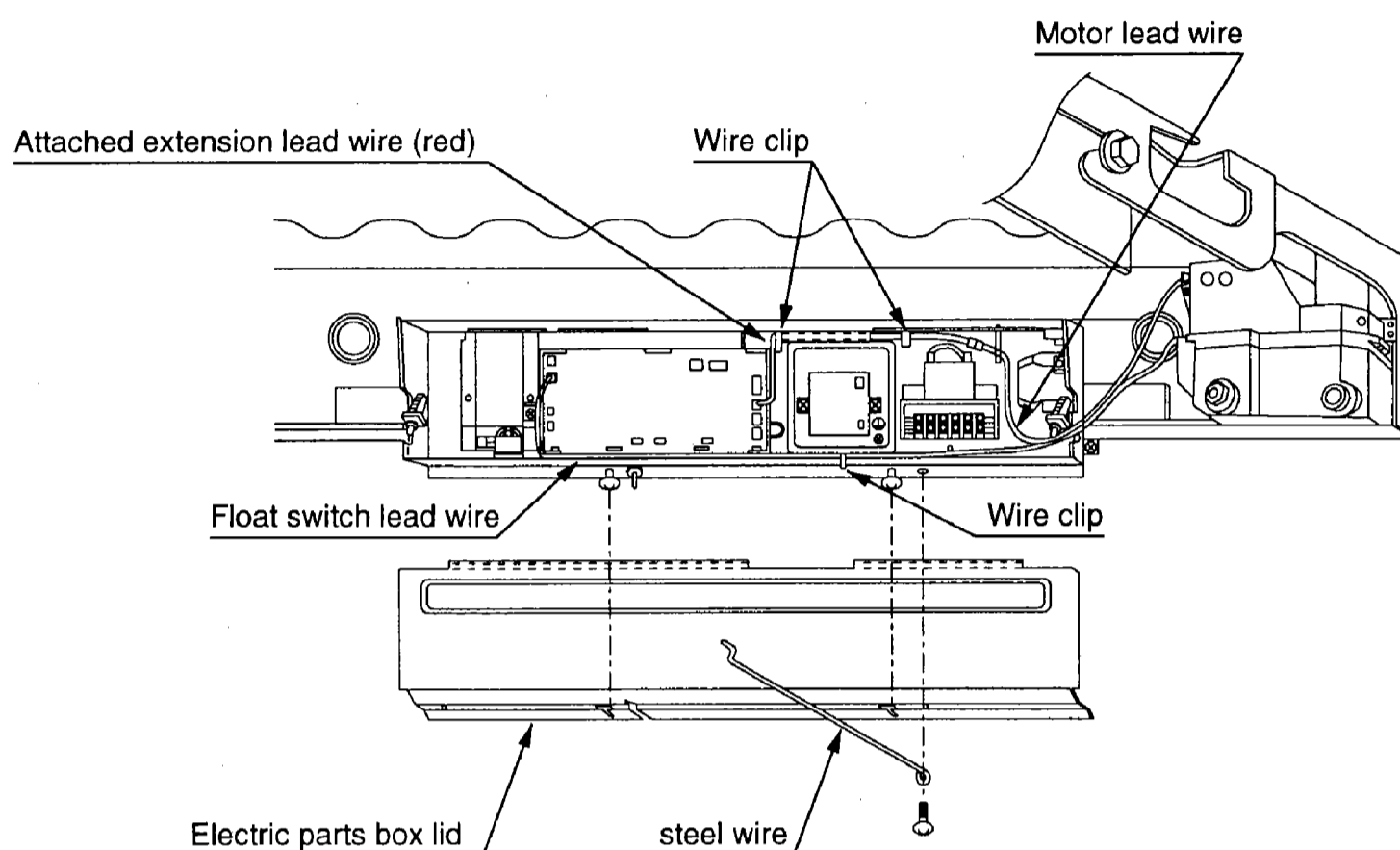


Fig. 13

## 6. Suction grille · Air filter Installation

Referring to the installation manual of the air conditioner, secure the side panel, blind plate (in the kit), suction grille, air filter and steel wire in the reverse steps. When attaching the blind plate, be careful not to get the lead wires caught by the plate.

## 7. Setting up the test operation

Pour about 1500 cc of water gradually into the blow port to see if the air conditioner drains well. To check the drainage, take the following steps.

### Drain Pump Kit Operation Manual

- Change the emergency switch on the PC board of the indoor unit from "Normal" to "Emergency", and supply the power (220-240V single phase) to the terminal No.1 and No.3 and check the operation of drain pump. Be sure to supply the power to the power after changing the switch. Be careful the fan is also be operated at the same time.
- After checking of the operation of the drain pump, be sure to change the switch to "Normal" position.

## 11.2 Replacement long life filter —KAFJ501F56·80·112·160

### ● Specifications

Model \ Item	KAFJ501F56	KAFJ501F80	KAFJ501F112	KAFJ501F160
Effective life, Average efficiency	2500 hours (at dust particle concentration of 0.15mg/m <sup>3</sup> ), 45% (by weight method)			
Filter materials	Mold prevention resin net		Mold prevention resin net	
Nos. required	2 pieces		2 pieces	
Applicable model	For indoor unit 35F~45F	For indoor unit 60F~71F	For indoor unit 100F	For indoor unit 125F

## 11.3 L-type piping kit (for upward direction) — KHFJ5F50·60·80·160

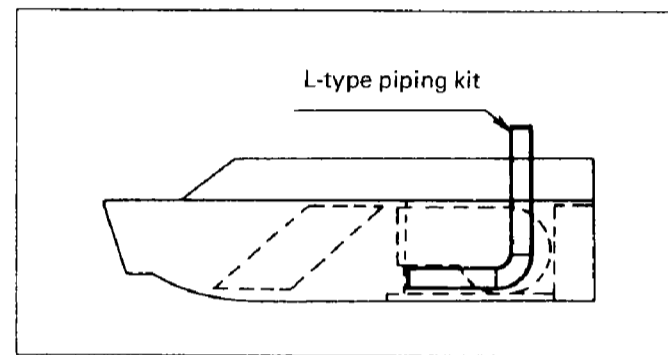
### ● Applicable model

Model \ Item	KHFJ5F50	KHFJ5F60	KHFJ5F80	KHFJ5F160
Applicable model	For indoor unit 35F	For indoor unit 45F~60F	For indoor unit 71F	For indoor unit 100F~125F

### ● Application

When you install the refrigerant piping in the ceiling, the piping is required to be bent L-type in the unit as shown on the right. This L-type piping kit is developed to facilitate such installation.

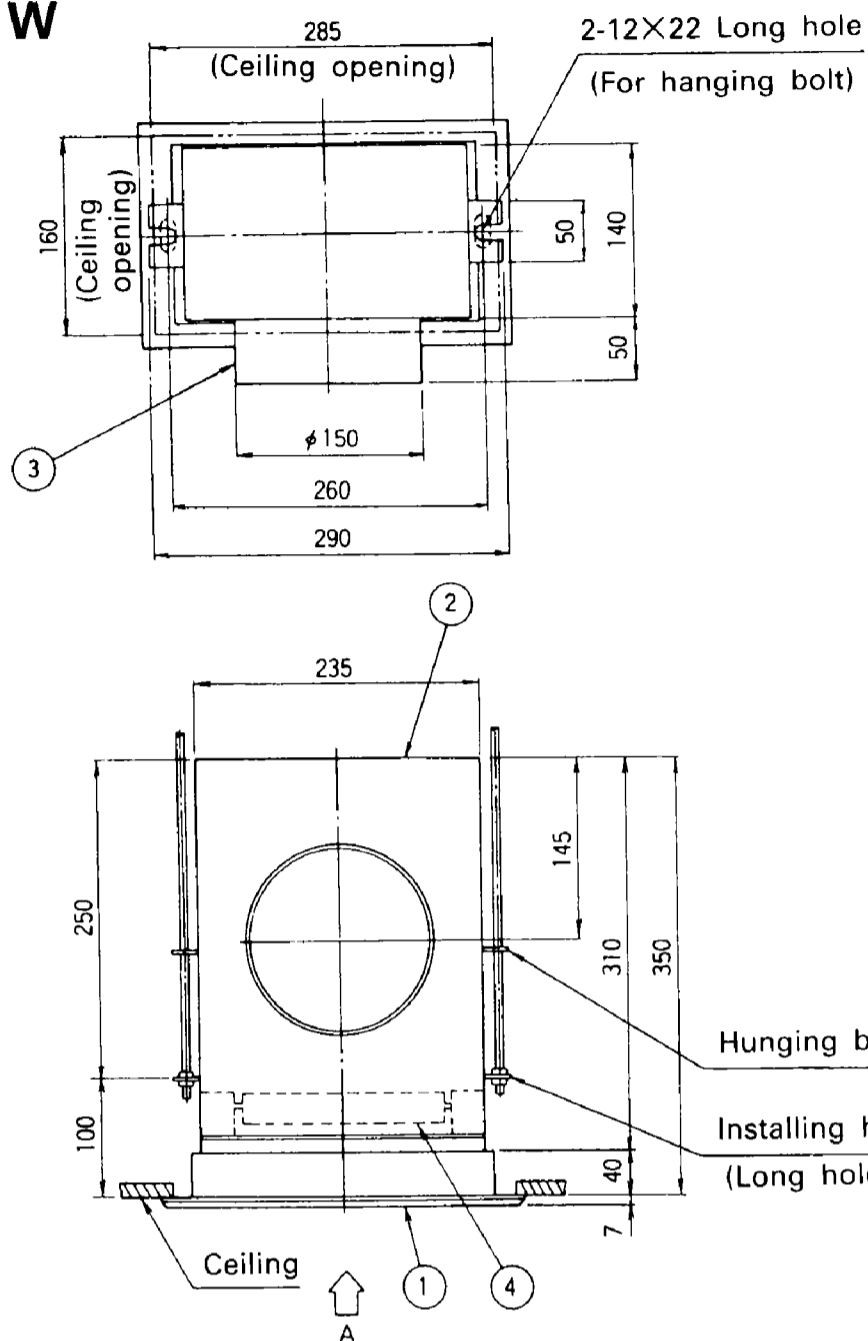
### ● Installation



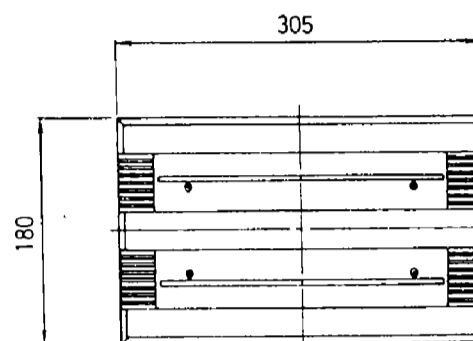
# 11.4 Optional kit installation drawing

## Discharge grille+Discharge chamber <math>\phi 150</math>

### KDG90D4-1W

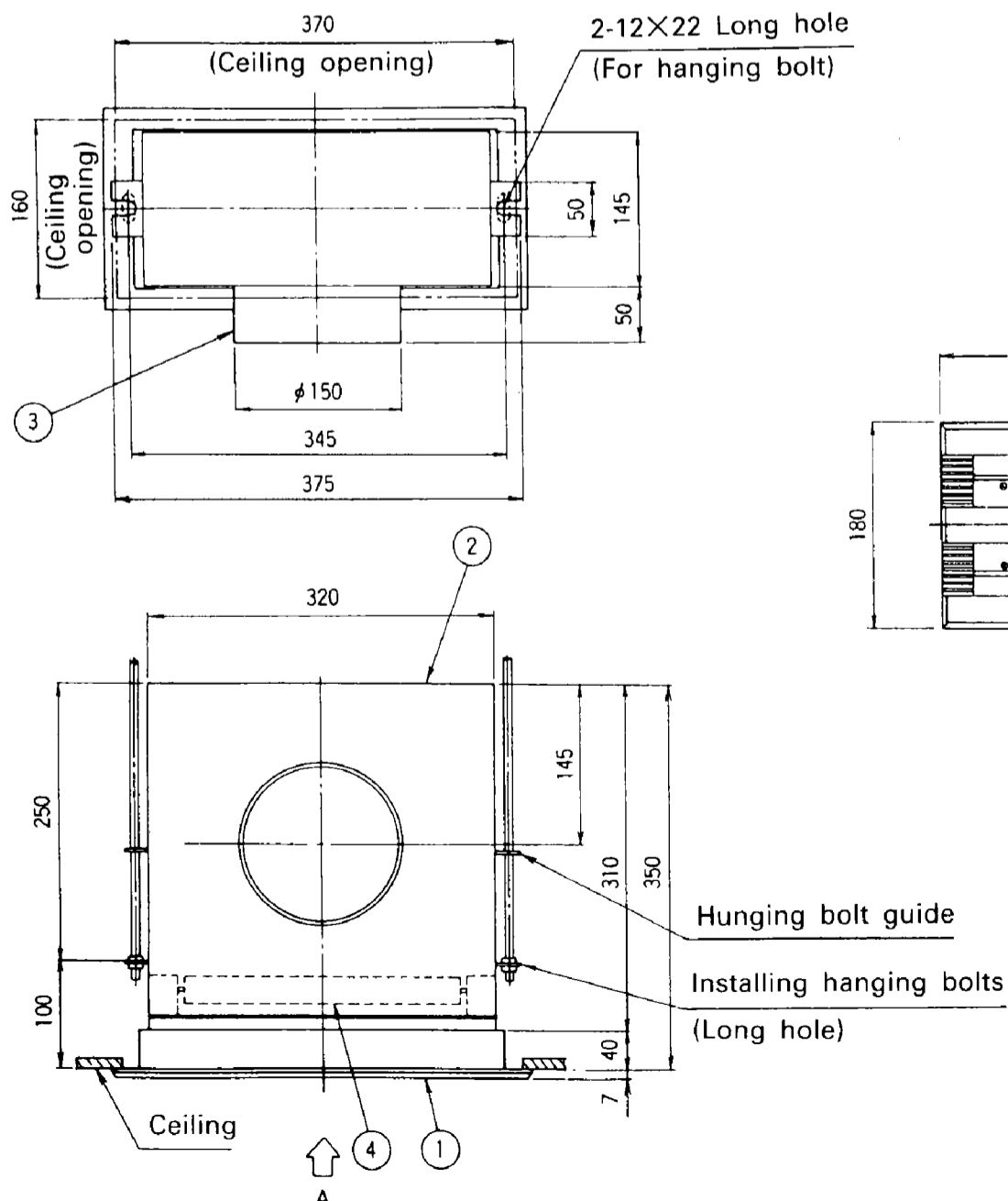


- ① Discharge grill (KDG90D4-1)
- ② Discharge chamber (KDG90B4-2)
- ③ Duct ( $\phi 150$ )
- ④ Shutter

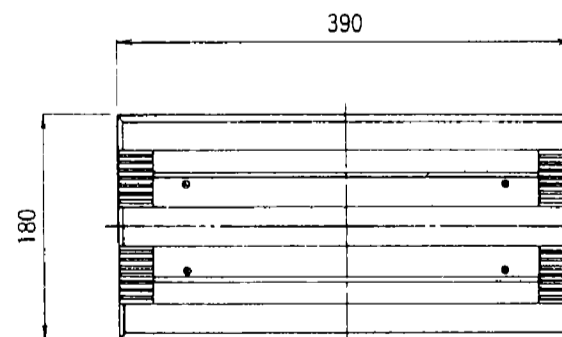


View A

### KDG90D5-1W



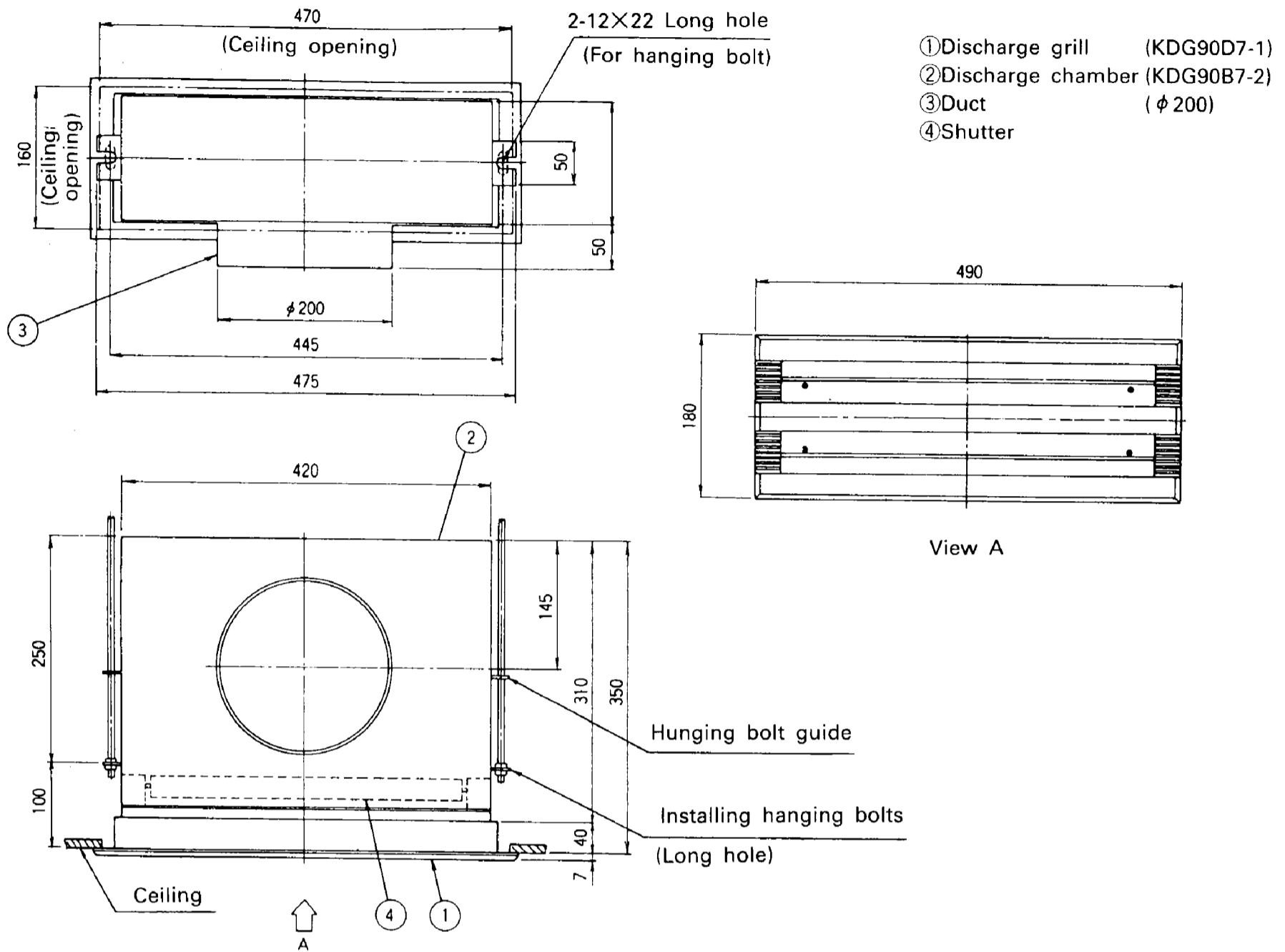
- ① Discharge grill (KDG90D5-1)
- ② Discharge chamber (KDG90B5-2)
- ③ Duct ( $\phi 150$ )
- ④ Shutter



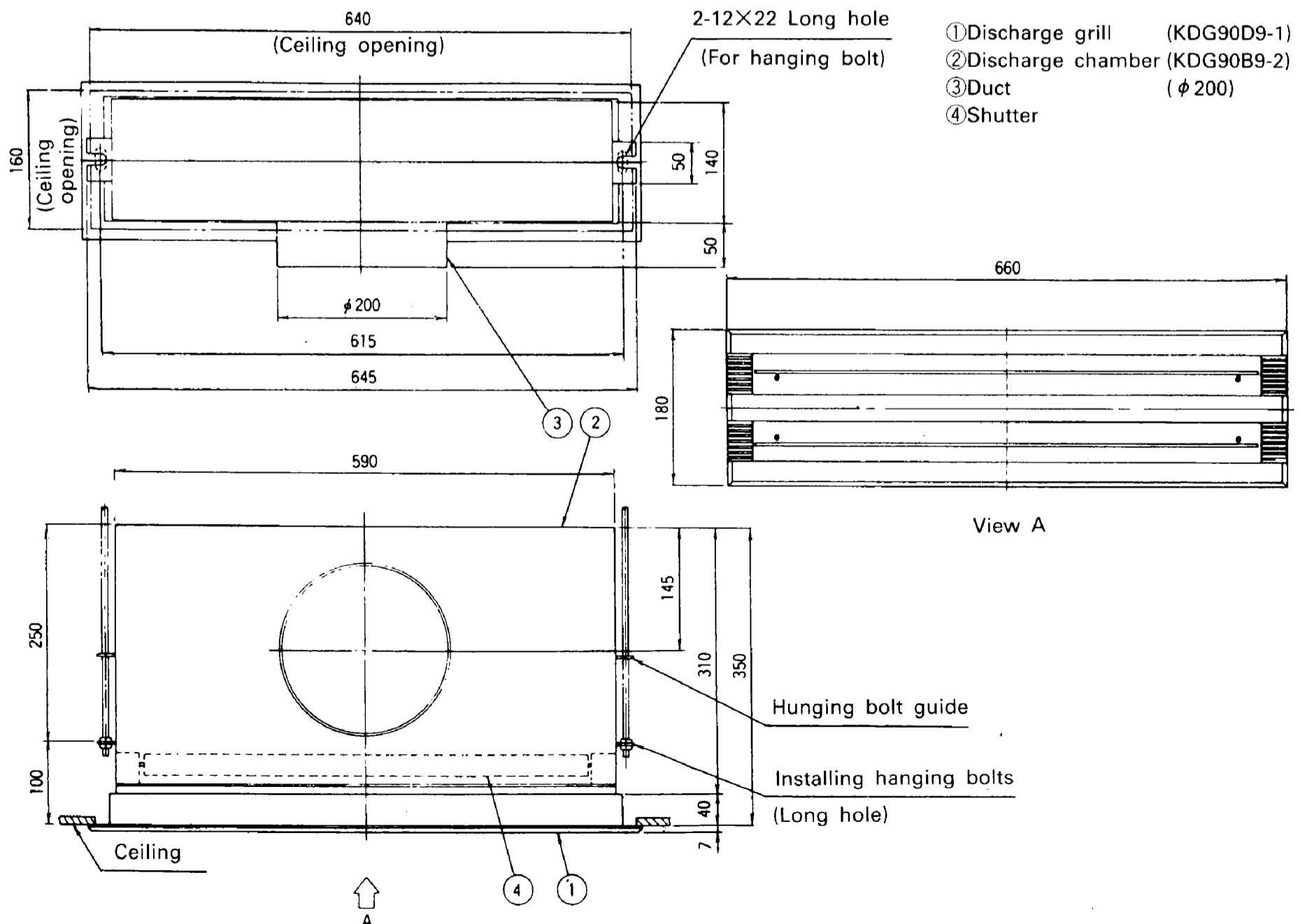
View A

# Discharge grille+Discharge chamber < $\phi 200$ >

## KDG90D7-1W



## KDG90D9-1W



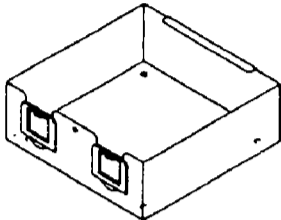
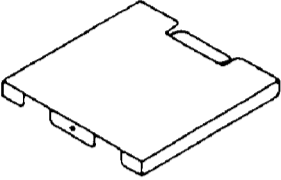


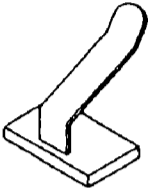
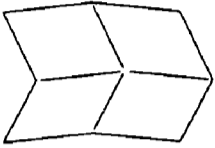
## 11.5 Installation box for adaptor PCB—KRP1B93

### Caution

- This kit can only be installed on the ceiling suspended type.
- This kit is required for each adaptor PCB.

### Contents of kit

Prior to installation check whether you have the complete kit of parts as shown below including the installation manual.

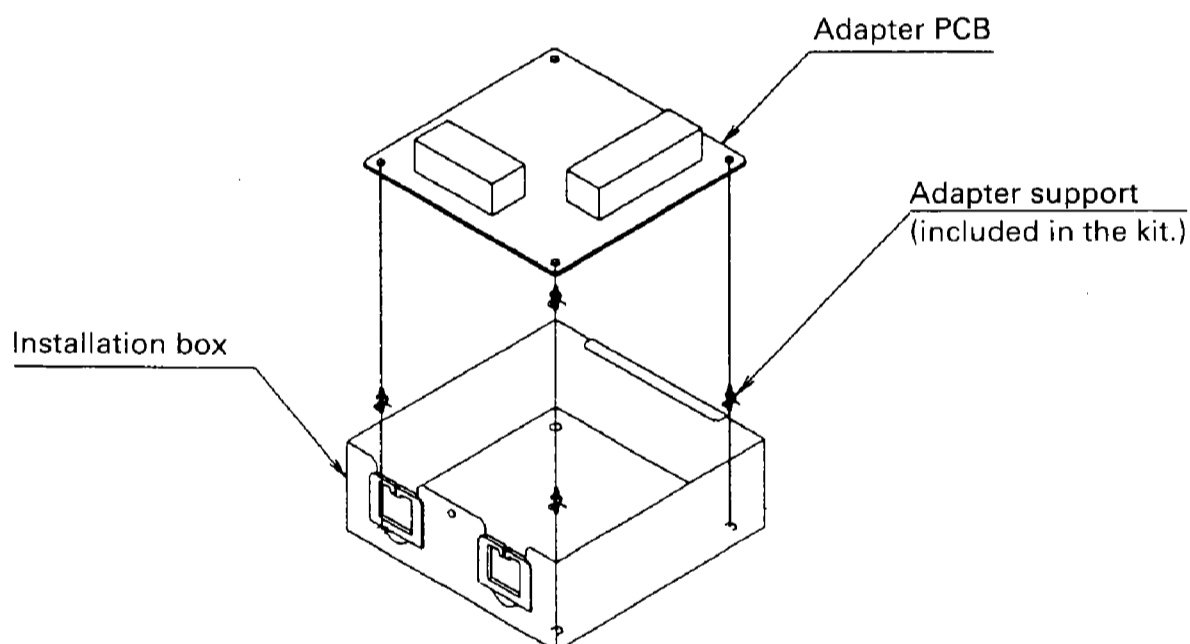
Name	Installation box	Box cover	Screws for fixing box	Hexagon screws for fixing box cover	Cable clamp	Installation manual
Shape						
Quantity	1 piece	1 piece	M4×8 1 piece	M4×8( 1 piece	2 pieces	1 piece

### Applicable PCB

Name of PCB	Kit name
Adapter PCB for remote control	KRP4A2

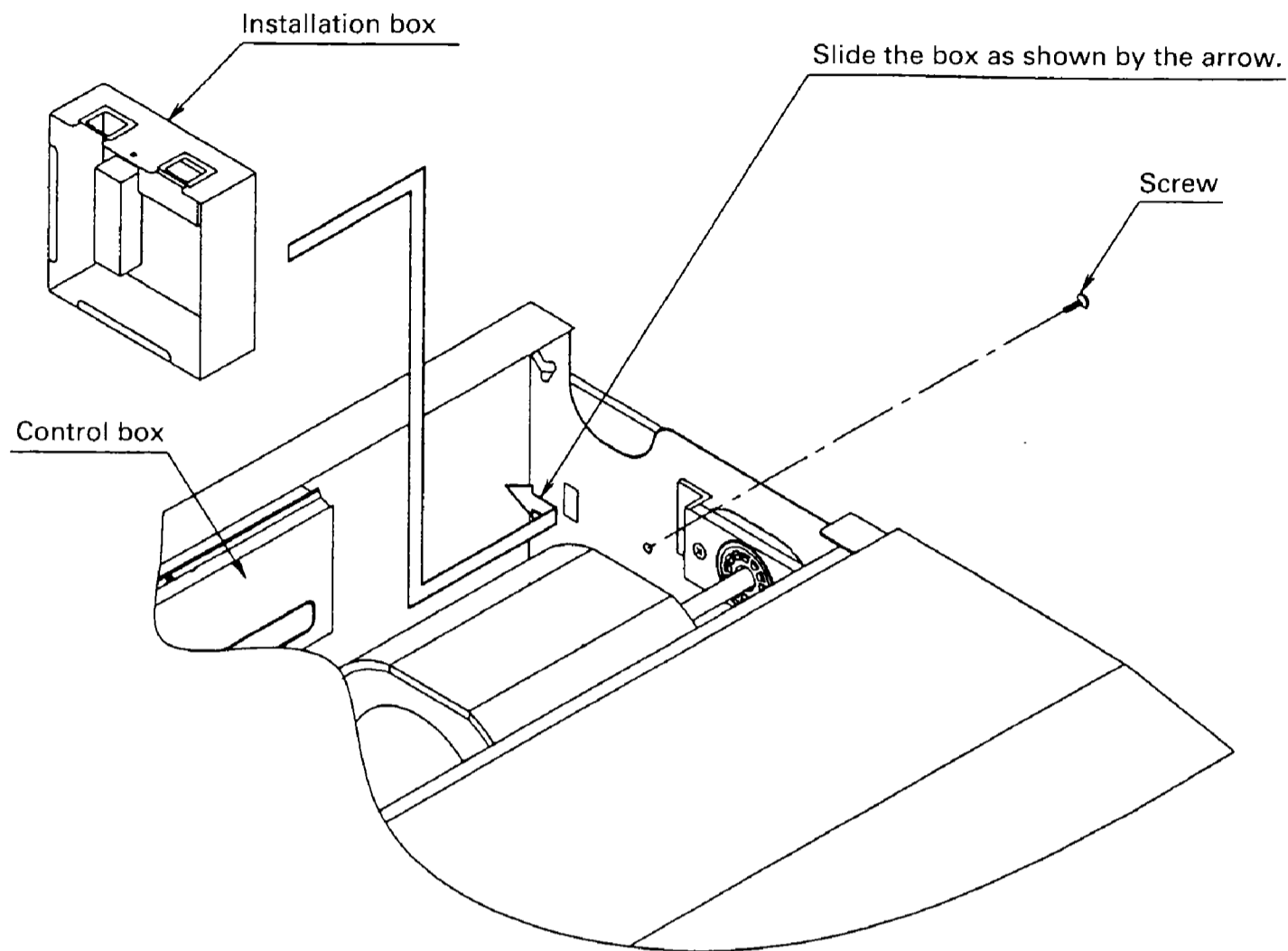
## 1. Installation of adapter PCB <Refer to the installation manual of Adapter PCB as well.>

- Fix the adapter support (4 pieces) to the installation box. The adapter supports are included in the adapter PCB kit.
- Fix the adapter PCB to the adapter supports.



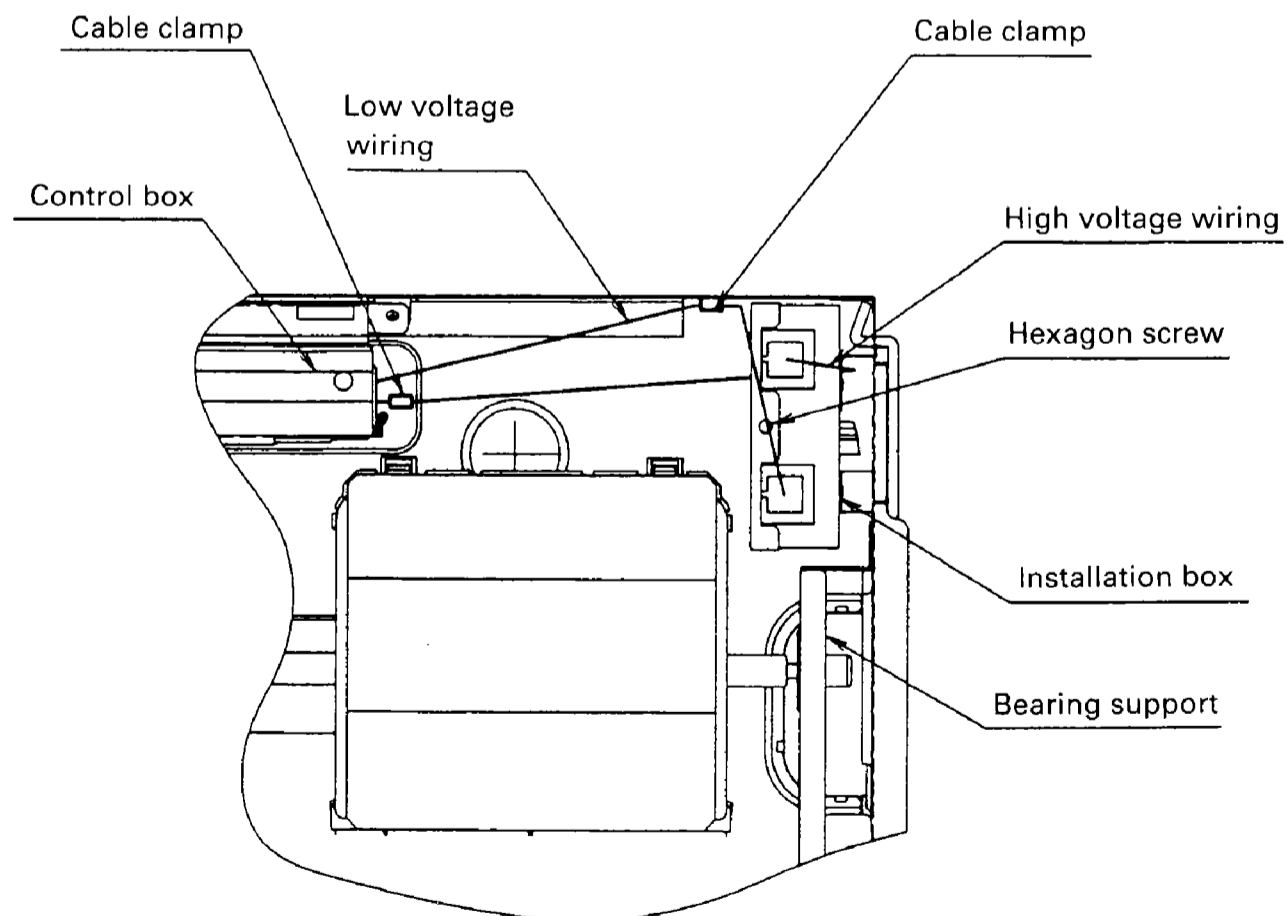
## 2. Installation to the indoor unit

- Fix the installation box to the indoor unit with screws included in the kit.  
(Be sure to fix the installation box after setting the adapter PCB.)



## 3. Electrical wiring

- Refer to the installation manual of the adapter PCB for its electrical connection.
- After completing the electrical wiring, clamp the electrical cable with cable clamp included in the kit. Be sure the wiring is not bent.
- After checking the wiring connection, fix the box cover with the screws included in the kit.



## Outdoor Unit

### 1 Year-round cooling kit – KRK5F80V1-140V1

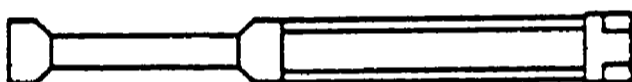

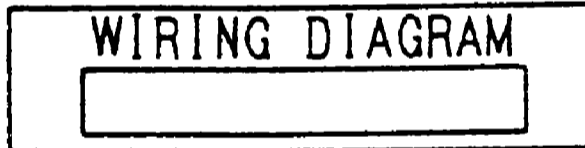
#### Confirm your model

Confirm the year-round cooling operation kit type and the outdoor unit model.

Type	Applicable outdoor unit
KRK5F80V1	R71FV1, R71FY1
KRK5F140V1	R100FV1, R100FY1, R125FY1


#### Confirm the accessories

Check if the following accessories are included with your kit before installation.

Accessories		Type	
Name	Shape	KRK5F80V1	KRK5F140V1
Crankcase heater		1	1
Clamp		3	4
Wiring Diagram		2	2

#### Precautions in use

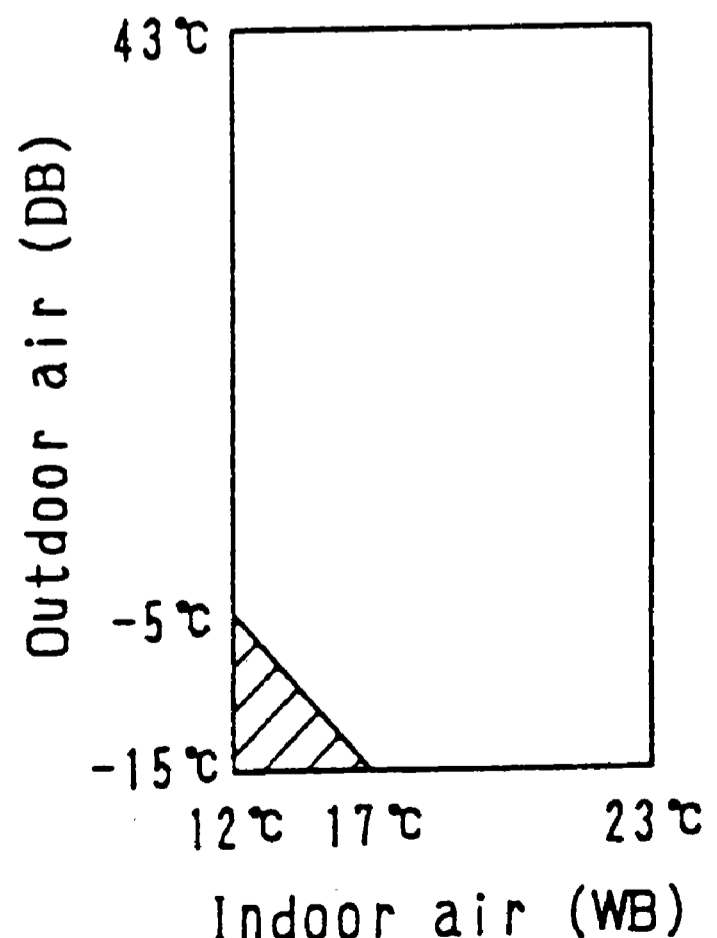
( Operation range )

In the operation range indicated by  part, compressor stops frequently due to prevention of freezing of the indoor unit.

( Installation site )

Install the outdoor unit by facing its back side towards a wall to avoid disturbance of the wind.

Where no wall is present as on a roof, be sure to install optional snow prevention hood.



## Installation procedure

- (1) Attach crankcase heater to the compressor as in Fig. 1. Lead wire cannot come in contact with the pipes so pass it through the route of other lead wires.
- (2) Connect crank case heater to X25A connector above PCB assy as in Fig. 2.
- (3) Bundle lead wires of crankcase heater using the attached clamp at the same point where they were bundled before conversion.
- (4) Attach wiring diagram over the wiring diagram label.  
(Confirm the outdoor unit model)

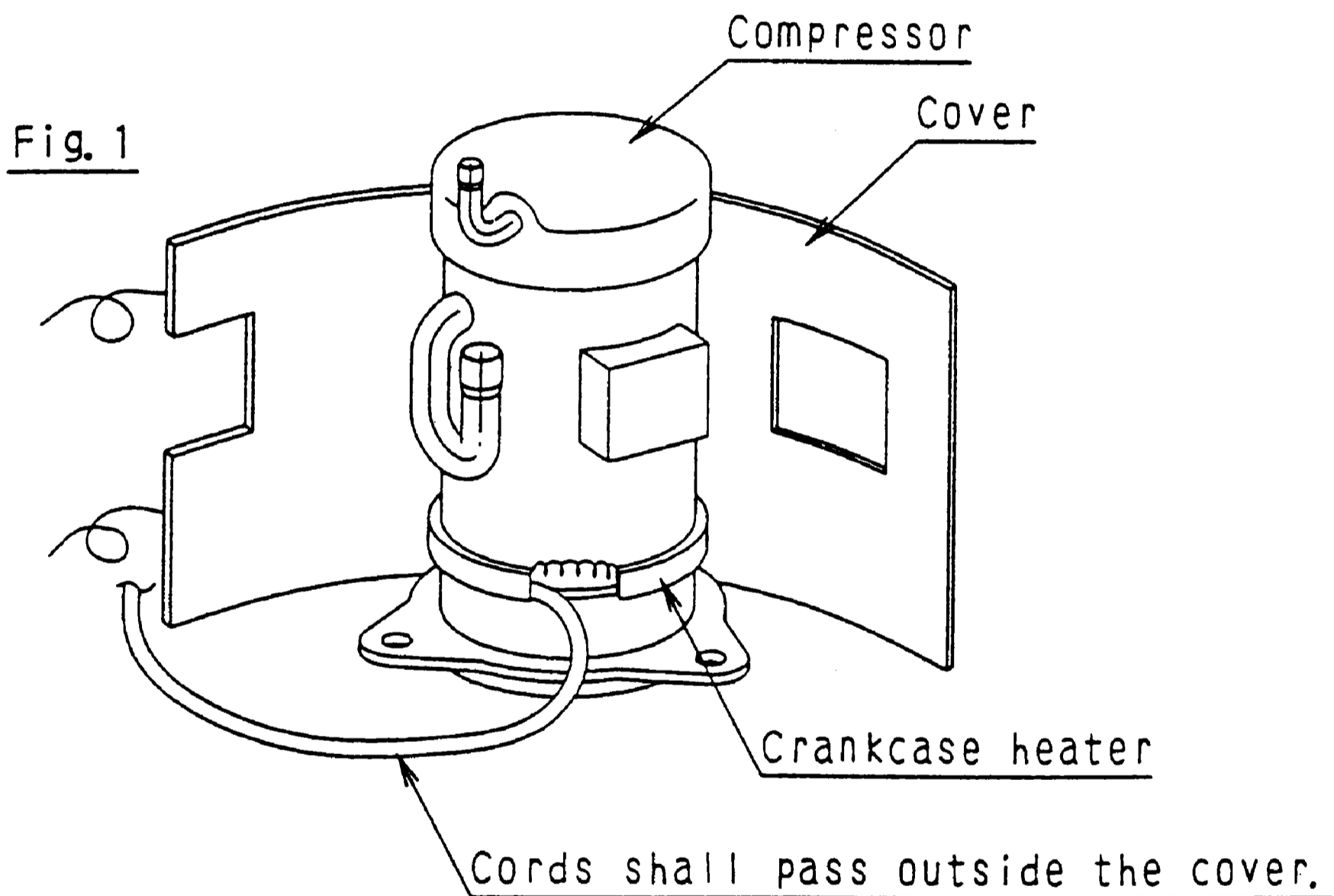
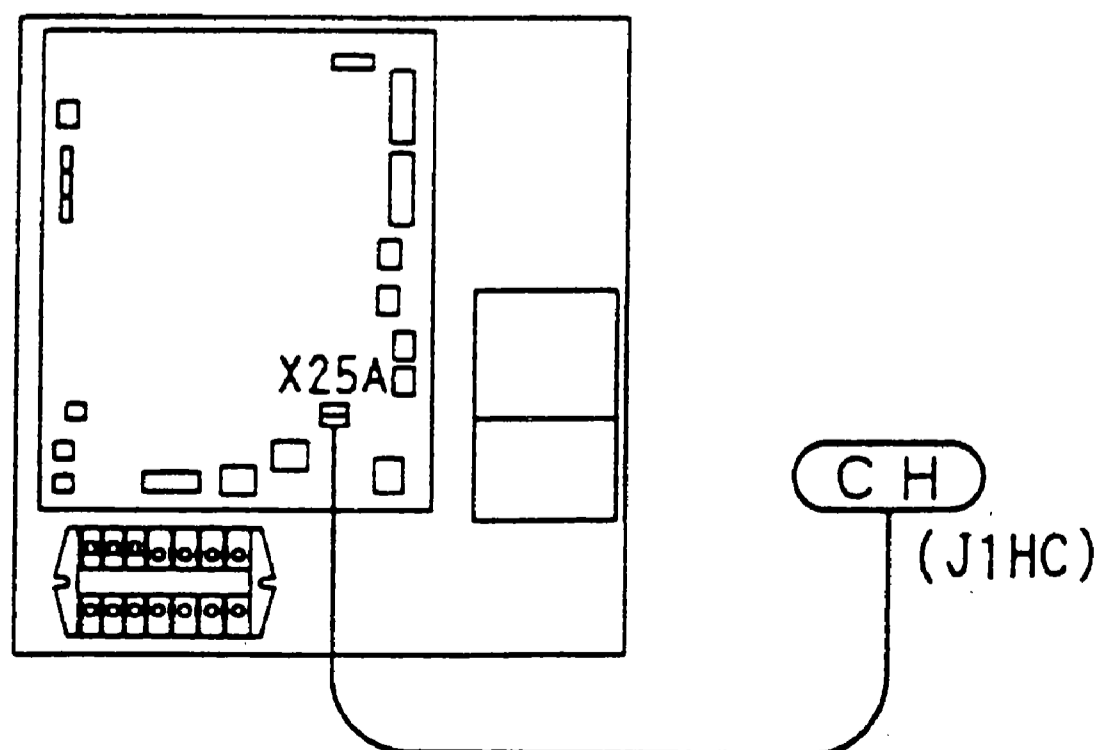
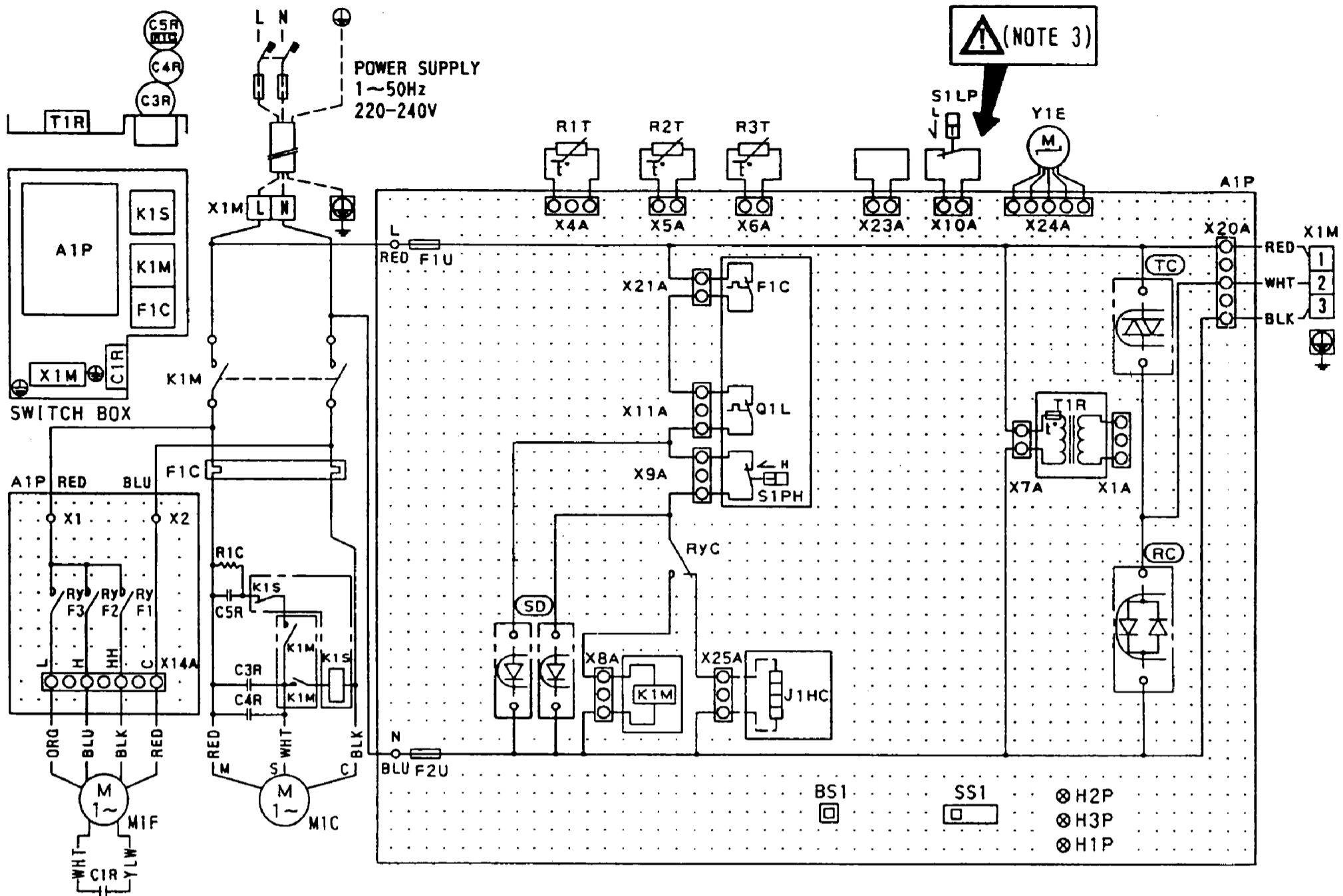


Fig. 2





# For R71FV1

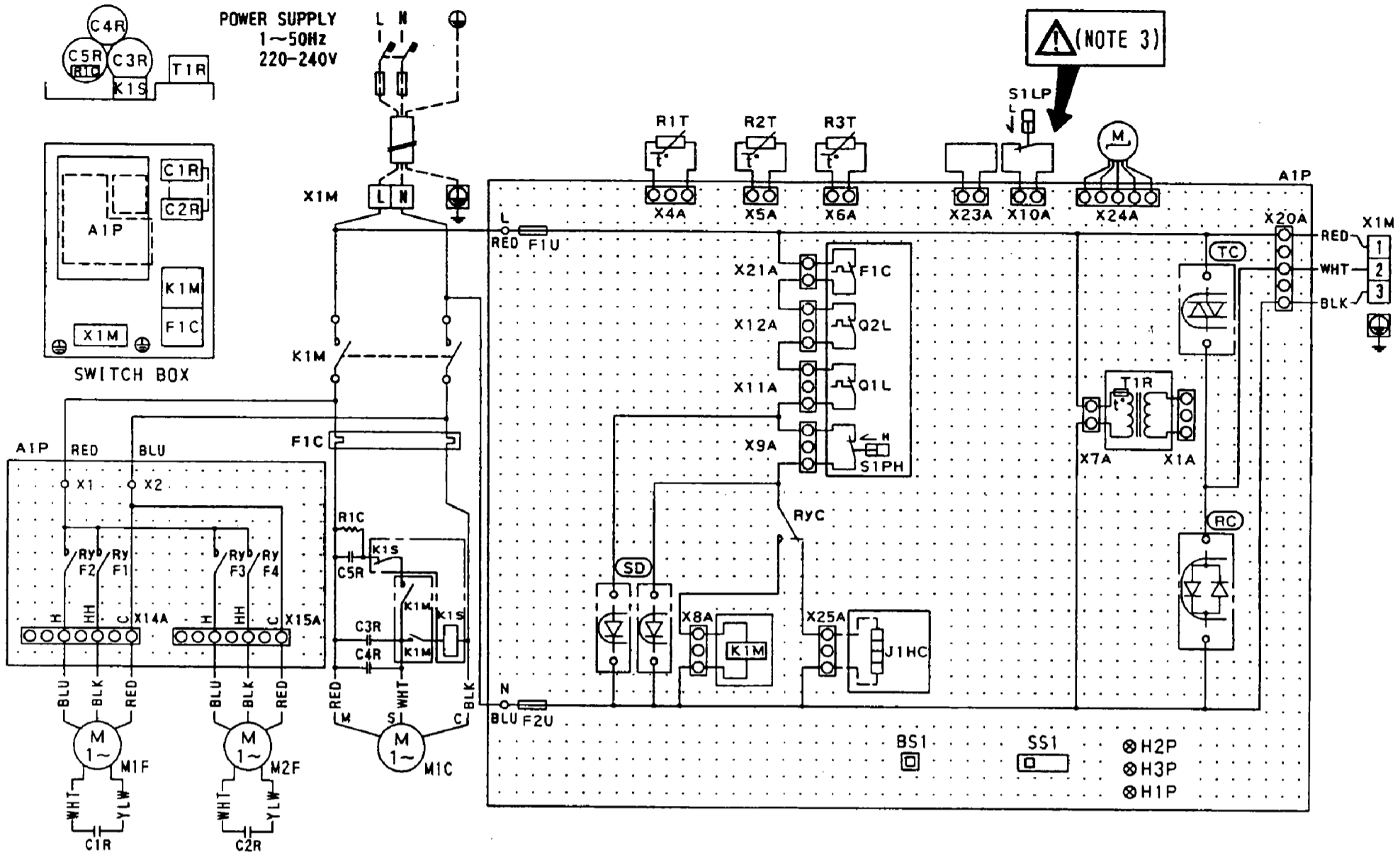


L-RED	N-BLU		
Y1E	EXPANSION VALVE (ELECTRONIC TYPE)		
Q1L	THERMO SWITCH (MIF)		
F1C	OVER-CURRENT RELAY (MIC)		
K1M	MAGNETIC CONTACTOR (MIC)		
K1S	STARTING CONTACTOR (MIC)		
S1PH	PRESSURE SWITCH (HIGH)		
S1LP	PRESSURE SWITCH (LOW)		
BS1	PUSH BUTTON(PUMP DOWN)		
C1R	CAPACITOR (MIF)		
C3R·C4R	CAPACITOR (MIC)		
C5R	STARTING CAPACITOR (MIC)		
J1HC	CRANKCASE HEATER		
A1P	PRINTED CIRCUIT BOARD		
F1U·F2U	FUSE (250V, 5A)		
H1P	LIGHT-EMITTING DIODE(SERVICE MONITOR-GREEN)		
H2P	LIGHT-EMITTING DIODE(SERVICE MONITOR-RED)		
H3P	LIGHT-EMITTING DIODE(SERVICE MONITOR-RED)		
MIC	MOTOR (COMPRESSOR)		
MIF	MOTOR (FAN)		
RYC	MAGNETIC RELAY (K1M)		
RYF1·2·3	MAGNETIC RELAY (MIF)		
SS1	SELECTOR SWITCH(EMERGENCY)		
X1M	TERMINAL STRIP		
R1C	RESISTOR		
R1T	THERMISTOR(AIR)		
R2T	THERMISTOR(COIL)		
R3T	THERMISTOR(DISCHARGE PIPE)		
T1R	TRANSFORMER(220-240V/16V)		
RC	SIGNAL RECEIVER CIRCUIT		
SD	SAFETY DEVICES INPUT		
TC	SIGNAL TRANSMISSION CIRCUIT		

## NOTES)

1. : TERMINAL  
 : CONNECTOR : WIRE CLAMP
2. ----- : FIELD WIRING
3. DO NOT OPERATE THE UNIT BY SHORT-CIRCUITING S1LP.
4. SYMBOLS SHOW AS FOLLOWS  
BLK:BLACK RED:RED ORG:ORANGE  
BLU:BLUE WHT:WHITE YLW:YELLOW
5. WIRING ---PART(J1HC) INDICATES THE YEAR-ROUND COOLING OPERATION KIT WHEN IT IS INSTALLED.

# For R100FV1

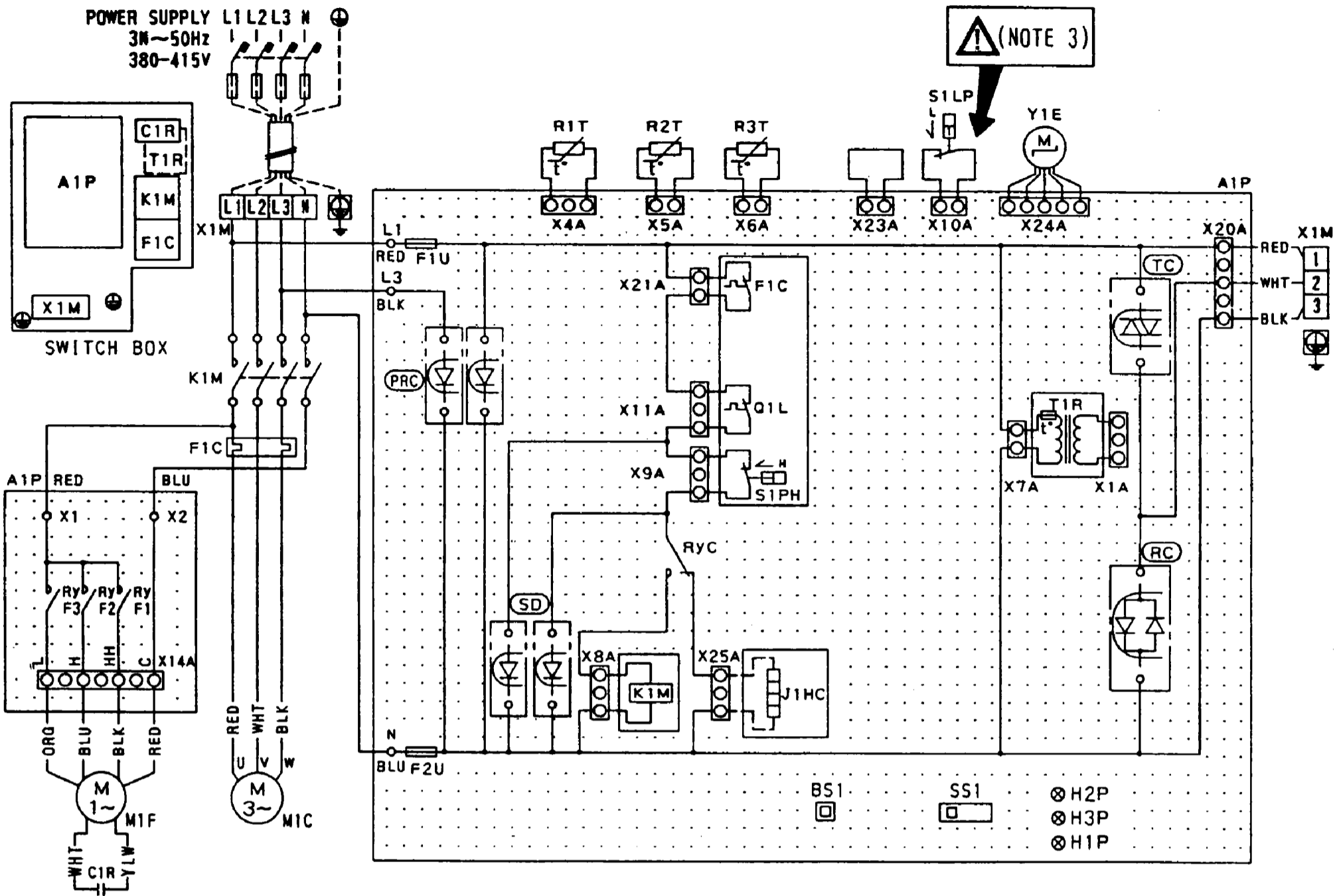


L-RED	N-BLU	C5R	STARTING CAPACITOR (M1C)	SS1	SELECTOR SWITCH(EMERGENCY)
Y1E	EXPANSION VALVE (ELECTRONIC TYPE)	J1HC	CRANKCASE HEATER	X1M	TERMINAL STRIP
Q1L-Q2L	THERMO SWITCH (M1F, M2F)	A1P	PRINTED CIRCUIT BOARD	R1C	RESISTOR
F1C	OVER-CURRENT RELAY (M1C)	F1U-F2U	FUSE (250V, 10A)	R1T	THERMISTOR(AIR)
K1M	MAGNETIC CONTACTOR (M1C)	H1P	LIGHT-EMITTING DIODE(SERVICE MONITOR-GREEN)	R2T	THERMISTOR(COIL)
K1S	STARTING CONTACTOR (M1C)	H2P	LIGHT-EMITTING DIODE(SERVICE MONITOR-RED)	R3T	THERMISTOR(DISCHARGE PIPE)
S1PH	PRESSURE SWITCH (HIGH)	H3P	LIGHT-EMITTING DIODE(SERVICE MONITOR-RED)	T1R	TRANSFORMER(220-240V/16V)
S1LP	PRESSURE SWITCH (LOW)	M1C	MOTOR (COMPRESSOR)	RC	SIGNAL RECEIVER CIRCUIT
BS1	PUSH BUTTON(PUMP DOWN)	M1F-M2F	MOTOR (FAN)	SD	SAFETY DEVICES INPUT
C1R-C2R	CAPACITOR (M1F-M2F)	RYC	MAGNETIC RELAY (K1M)	TC	SIGNAL TRANSMISSION CIRCUIT
C3R-C4R	CAPACITOR (M1C)	RYF1-2-3-4	MAGNETIC RELAY (M1F-M2F)		

## NOTES)

- : TERMINAL : CONNECTOR  
 : WIRE CLAMP
- : FIELD WIRING
- DO NOT OPERATE THE UNIT BY SHORT-CIRCUITING S1LP.
- SYMBOLS SHOW AS FOLLOWS  
 BLK:BLACK RED:RED  
 BLU:BLUE WHT:WHITE  
 YLW:YELLOW
- WIRING---PART(J1HC) INDICATES THE YEAR-ROUND COOLING OPERATION KIT WHEN IT IS INSTALLED.

# For R71FY1

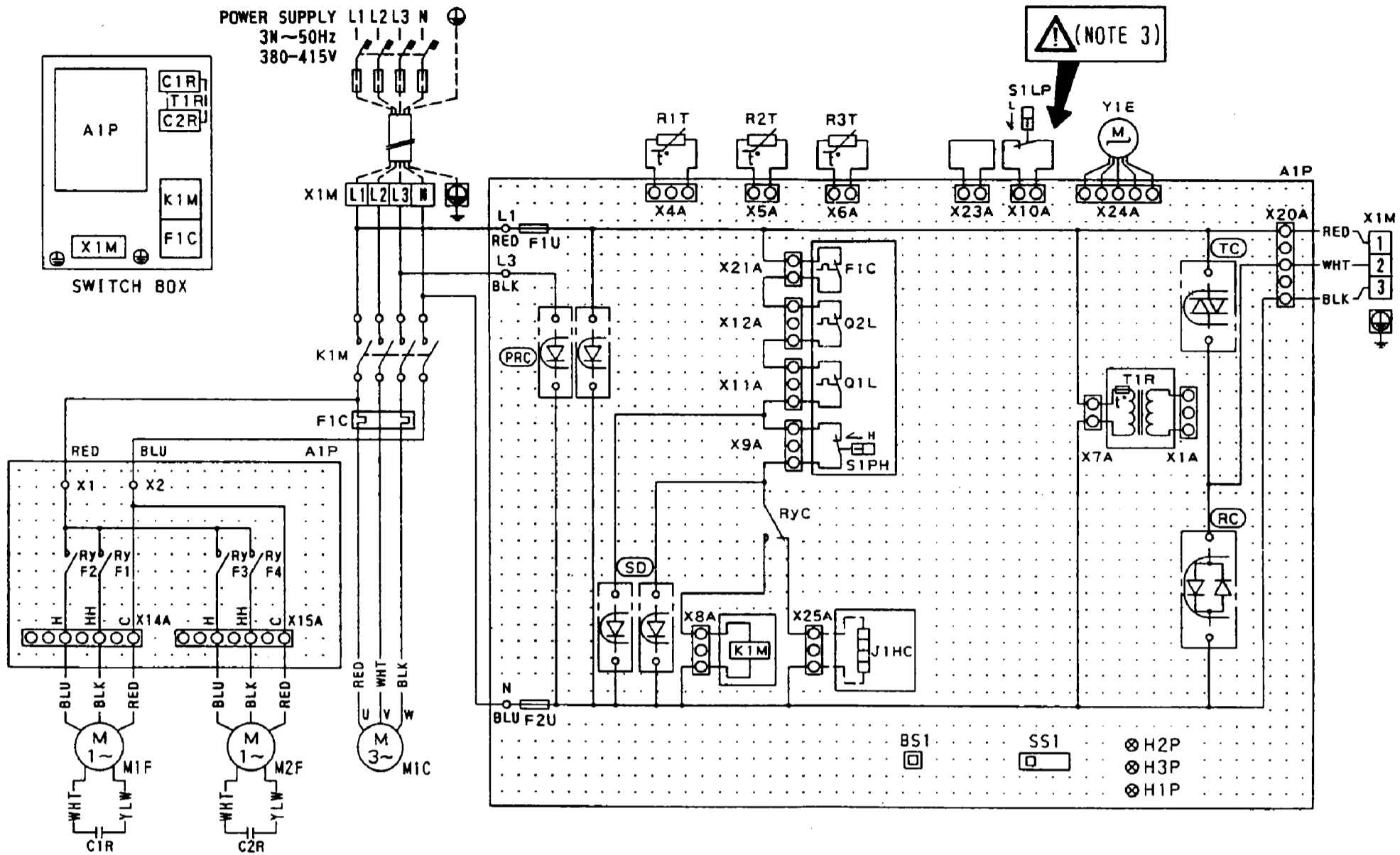


L1-RED	L2-WHT	L3-BLK	N-BLU
Y1E	EXPANSION VALVE (ELECTRONIC TYPE)		
Q1L	THERMO SWITCH (M1F)		
F1C	OVER-CURRENT RELAY (MIC)		
K1M	MAGNETIC CONTACTOR (MIC)		
S1PH	PRESSURE SWITCH (HIGH)		
S1LP	PRESSURE SWITCH (LOW)		
BS1	PUSH BUTTON (PUMP DOWN)		
C1R	CAPACITOR (M1F)		
J1HC	CRANKCASE HEATER		
A1P	PRINTED CIRCUIT BOARD		
F1U·F2U	FUSE (250V, 5A)		
H1P	LIGHT-EMITTING DIODE (SERVICE MONITOR-GREEN)		
H2P	LIGHT-EMITTING DIODE (SERVICE MONITOR-RED)		
H3P	LIGHT-EMITTING DIODE (SERVICE MONITOR-RED)		
M1C	MOTOR (COMPRESSOR)		
M1F	MOTOR (FAN)		
RYC	MAGNETIC RELAY (K1M)		
RYF1-2-3	MAGNETIC RELAY (M1F)		
SS1	SELECTOR SWITCH (EMERGENCY)		
X1M	TERMINAL STRIP		
R1T	THERMISTOR (AIR)		
R2T	THERMISTOR (COIL)		
R3T	THERMISTOR (DISCHARGE PIPE)		
T1R	TRANSFORMER (220-240V/16V)		
PRC	PHASE REVERSAL DETECT CIRCUIT		
RC	SIGNAL RECEIVER CIRCUIT		
SD	SAFETY DEVICES INPUT		
TC	SIGNAL TRANSMISSION CIRCUIT		

## NOTES)

1. : TERMINAL  
 : CONNECTOR : WIRE CLAMP
2. - - - : FIELD WIRING
3. DO NOT OPERATE THE UNIT BY SHORT-CIRCUITING S1LP.
4. SYMBOLS SHOW AS FOLLOWS  
 BLK:BLACK RED:RED ORG:ORANGE  
 BLU:BLUE WHT:WHITE YLW:YELLOW
5. WIRING --- PART (J1HC) INDICATES THE YEAR-ROUND COOLING OPERATION KIT WHEN IT IS INSTALLED.

# For R100 · 125FY1



L1-RED	L2-WHT	L3-BLK	N-BLU	A1P	PRINTED CIRCUIT BOARD	X1M	TERMINAL STRIP
Y1E	EXPANSION VALVE (ELECTRONIC TYPE)			F1U · F2U	FUSE (250V, 10A)	R1T	THERMISTOR(AIR)
Q1L · Q2L	THERMO SWITCH (M1F, M2F)			H1P	LIGHT-EMITTING DIODE(SERVICE MONITOR-GREEN)	R2T	THERMISTOR(COIL)
F1C	OVER-CURRENT RELAY (M1C)			H2P	LIGHT-EMITTING DIODE(SERVICE MONITOR-RED)	R3T	THERMISTOR(DISCHARGE PIPE)
K1M	MAGNETIC CONTACTOR (M1C)			H3P	LIGHT-EMITTING DIODE(SERVICE MONITOR-RED)	T1R	TRANSFORMER(220-240V/16V)
S1PH	PRESSURE SWITCH (HIGH)			M1C	MOTOR (COMPRESSOR)	(PRC)	PHASE REVERSAL DETECT CIRCUIT
S1LP	PRESSURE SWITCH (LOW)			M1F · M2F	MOTOR (FAN)	(RC)	SIGNAL RECEIVER CIRCUIT
BS1	PUSH BUTTON(PUMP DOWN)			RYC	MAGNETIC RELAY (K1M)	(SD)	SAFETY DEVICES INPUT
C1R · C2R	CAPACITOR (M1F · M2F)			RYF1-2-3-4	MAGNETIC RELAY (M1F · M2F)	(TC)	SIGNAL TRANSMISSION CIRCUIT
J1HC	CRANKCASE HEATER			SS1	SELECTOR SWITCH(EMERGENCY)		

## NOTES)

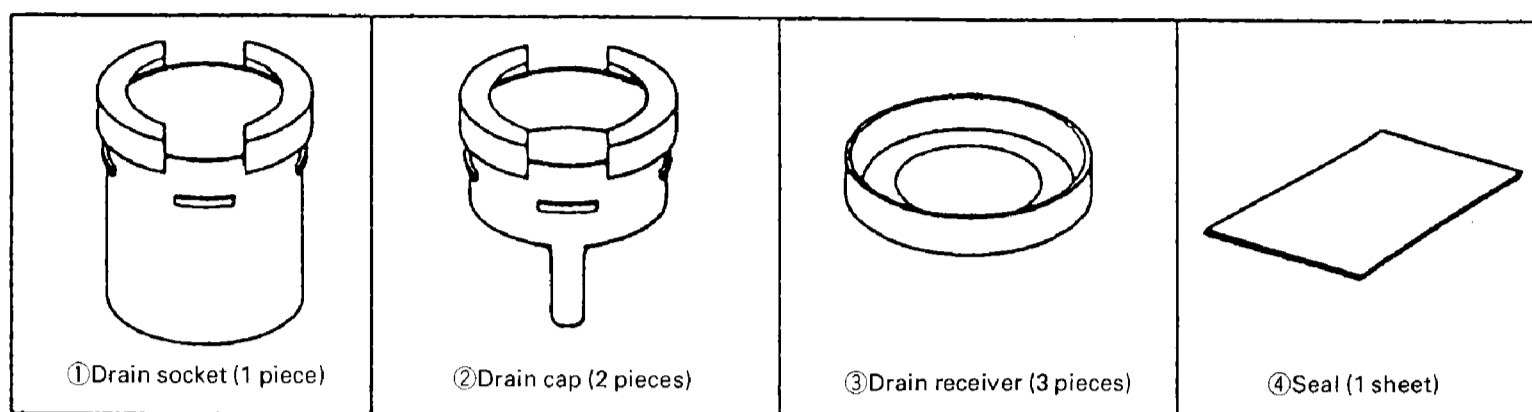
1. : TERMINAL : CONNECTOR  
 : WIRE CLAMP
2. --- : FIELD WIRING
3. DO NOT OPERATE THE UNIT BY SHORT-CIRCUITING S1LP.
4. SYMBOLS SHOW AS FOLLOWS  
 BLK:BLACK RED:RED  
 BLU:BLUE WHT:WHITE  
 YLW:YELLOW
5. WIRING --- PART(J1HC) INDICATES THE YEAR-ROUND COOLING OPERATION KIT WHEN IT IS INSTALLED.

## 2 Central drain plug – KKPJ5F180

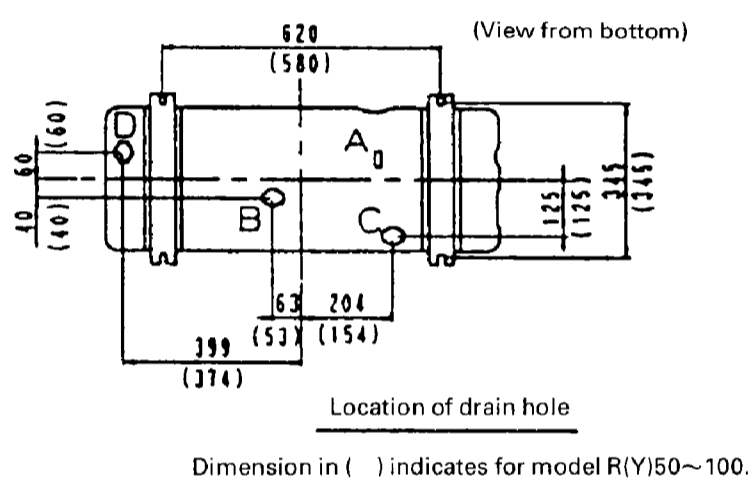
### Installation manual

● Use this plug to connect a drain hose to dispose the drain from the outdoor unit.

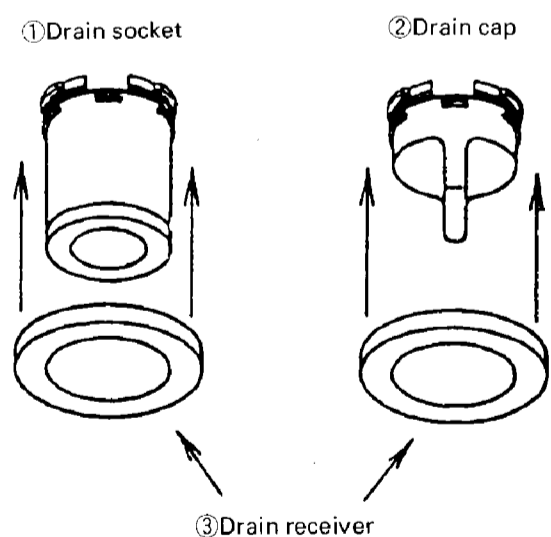
[1] Check that this kit contains the following parts.



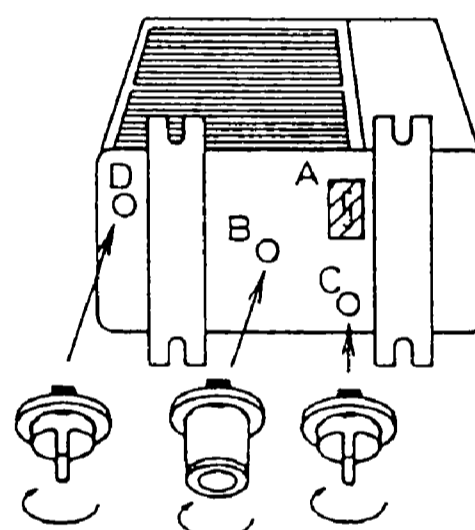
[2] Installation procedure



① Insert drain receiver ③ onto drain socket ① and drain cap ② beyond 4 projections around drain socket and drain cap.



② Insert drain socket and drain caps into their matching drain hole; Drain socket ① into drain hole B and drain caps ② into drain hole C and D. After insertion, turn them about 40° clockwise.



(Be sure not to insert them into wrong drain holes, or there causes water leakage.)

③ Connect vinyl hose on the market (internal diameter of 25mm) to drain socket ①. (If the hose is too long and hangs down, fix it carefully to prevent the kinks.)

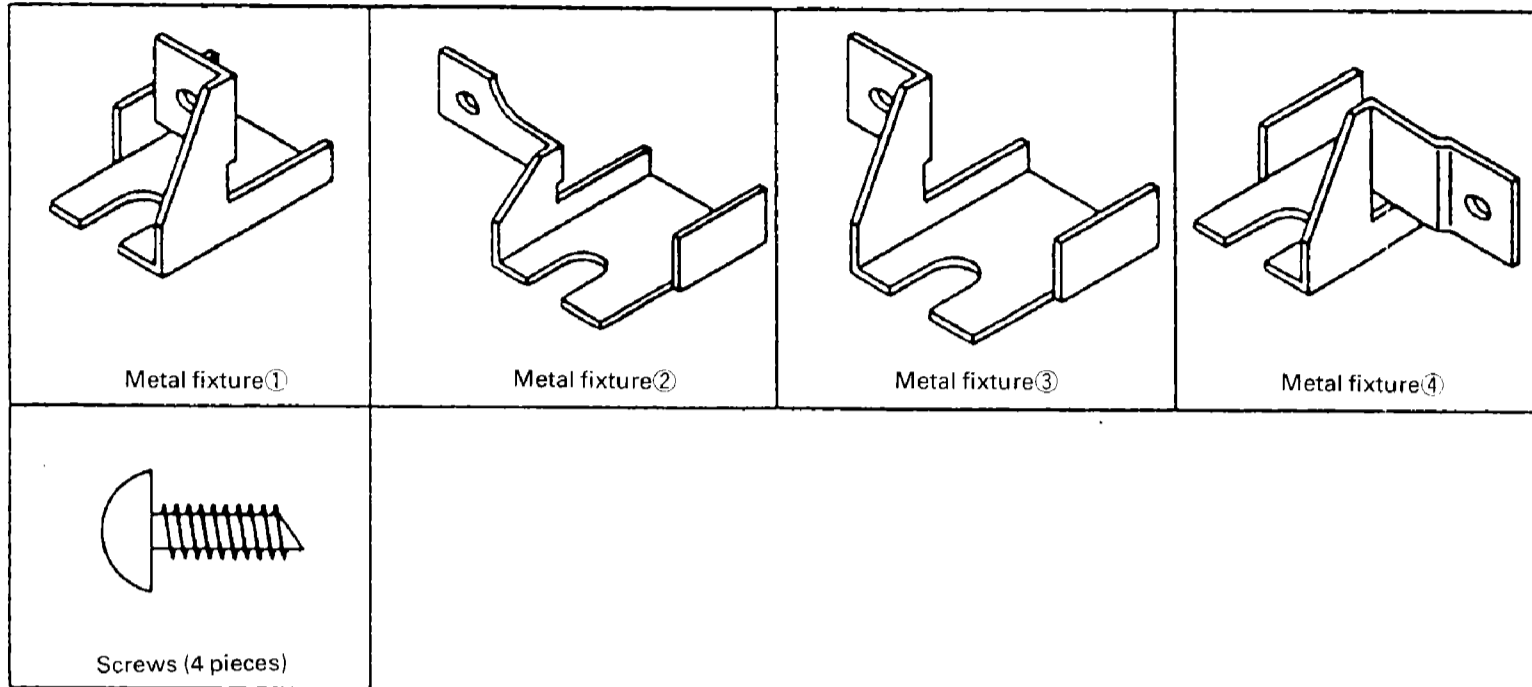
④ Affix seals ④ to part A as shown on the above drawing.

Note: If the drain holes of the outdoor unit are covered with the mounting bracket or the floor, raise the unit to provide the space of more than 100mm under the leg of the outdoor unit.

### 3 Fixture for preventing overturning – KPTJ60F160

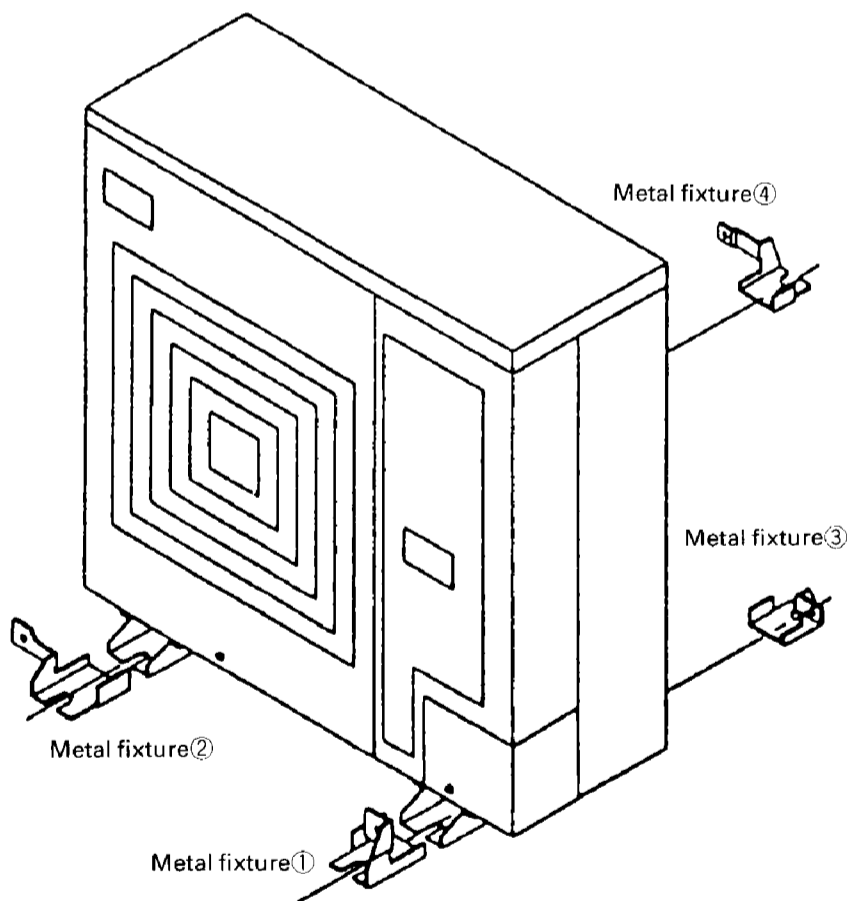
#### Installation manual

[1] Check that this kit contains the following parts.

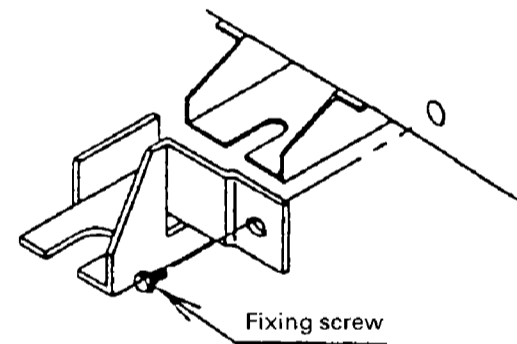


#### [2] Installation procedure

① Install the metal fixtures ①~④ to the base legs as shown below.



② Remove the screw from the casing and fix the metal fixture to the casing.



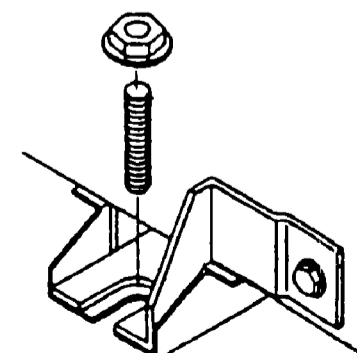
Note: For RY-F model

When you install the metal fixtures①,③ and④, fix the metal fixture to the casing by the screws M5×13 attached.

For other model

When you install the metal fixture②, fix the metal fixture to the casing by the screw M5×13 attached. However, remove the screw on the casing, if the screw of the casing will contact with metal fixture.

③ Fix the metal fixtures firmly by the anchor bolts.(The anchor bolts, nuts and washers should be M12 type sold on the market.)



## 4 Auxiliary piping – KHFJ5F80F-180F-80B-180B

This auxiliary piping set should be used when you have difficulties to connect the local piping direct to the outdoor unit. This piping set makes easy to connect the local piping at the outside of the unit.

### 3. Cautions during the installation

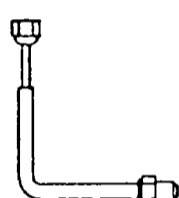
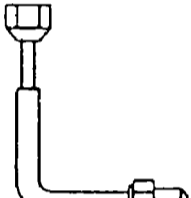
Be sure that the piping shall not contact to the compressor or the casing when you connect the auxiliary piping, which causes the vibration or abnormal sound.

### 1. Applied model

KHFJ5F80F KHFJ5F80B	RY71F R71F
KHFJ5F180F KHFJ5F180B	RY100F-RY125F R100F-R125F

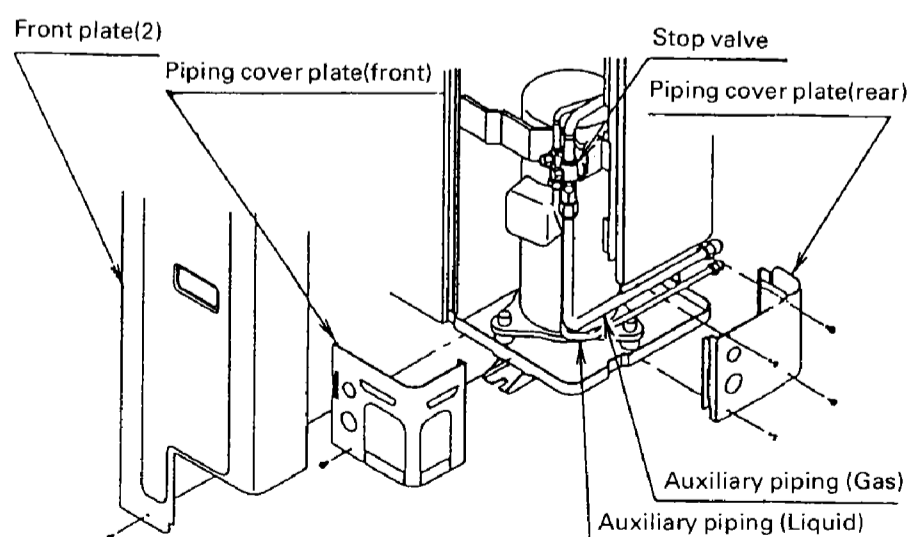
<Checking of contents>

Check that this kit contains the following parts.

Parts		Liquid pipe (small)		Gas pipe (large)	
Type					
For front/ side	KHFJ5F80F	φ 9.5		φ 15.9	
	KHFJ5F180F			φ 19.1	
For rear	KHFJ5F80B			φ 15.9	
	KHFJ5F180B			φ 19.1	

### 2. Installation

Remove the front panel(2) and the piping cover plate (front). Remove also the piping cover plate (rear), when you connect the piping from the rear side of the outdoor unit. Connect the auxiliary piping for both the liquid and the gas to the stop valve by directing the piping toward the connection side. Refer to the installation manual of the outdoor unit for the details of the connection to the stop valve.



<When you connect the piping from rear side of the unit>

<b>2</b>	<b>Central Remote Controller .....</b>	<b>64</b>
	DCS302B61	
<b>3</b>	<b>Unified ON/OFF Controller .....</b>	<b>90</b>
	DCS301B61	
<b>4</b>	<b>Schedule timer .....</b>	<b>98</b>
	DST301B61	
<b>5</b>	<b>Adaptor for wiring .....</b>	<b>109</b>
	KRP1B51 · 54 · 56 · 57	
<b>6</b>	<b>Wiring adaptor for electrical appendices.....</b>	<b>112</b>
	KRP4A51 · 52 · 53 · 54	
<b>7</b>	<b>Interface adaptor for Sky Air Series .....</b>	<b>120</b>
	DTA102A52	
<b>8</b>	<b>Ceiling mounted cassette type [FH(Y)C] .....</b>	<b>123</b>
	8.1 Decoration panel	
	BYC71F-W1 · 125F-W1	
	8.2 Sealing member of air discharge outlet	
	KDBHJ55F80 · 160	
	8.3 Panel spacer	
	KDBJ55F80W · 160W	
	8.4 Air discharge grille	
	KAWJ55F80 · 160	
	KAWVJ55F80 · 160	
	8.5 Lifter style air suction grille	
	KDVJ55F80 · 160	
	8.6 Fresh air intake kit	
	KDDJ55F80 · 160	
	8.7 Sound absorption kit	
	KDDNJ55F80 · 160	
	8.8 High efficiency filter	
	KAFJ552F80 · 160, KAFJ553F80 · 160	
	KDDFJ55F80 · 160 (Filter chamber)	
	8.9 Replacement long-life filter	
	KAFJ551F80 · 160	
	KAFJ550F80 · 160	
	8.10 Installation box for adaptor PCB	
	KRP1B94	



- 8.11 Optional kit installation drawing
  - High efficiency filter
  - Fresh air intake kit (without duct fan)
  - Sound absorption kit
  - Lifter style suction grille
  - Panel spacer

**9 Ceiling mounted cassette corner type [FH(Y)K] .....158**

- 9.1 Decoration panel
  - BYK45FJW1 · 71FJW1
- 9.2 Panel spacer
  - KPBJ52F56W · 80W
- 9.3 Air discharge blind panel
  - KDBJ52F56W · 80W
- 9.4 Replacement long-life filter
  - KAFJ521F56 · 80
- 9.5 Discharge grille
  - KDGJ52F56W · 80W
- 9.6 Flexible duct with shutter
  - KFDJ52F56 · 80
- 9.7 Optional kit installation drawing
  - Panel spacer
  - Air discharge blind panel, Discharge grille and Flexible duct

**10 Ceiling mounted built-in type [FH(Y)B] .....185**

- 10.1 Decoration panel
  - BYBS45D-W2 · 71D-W2 · 125D-W2
- 10.2 Service access panel
  - KTBJ25K56W · 80W · 160W
- 10.3 High-efficiency filter
  - KAFJ252K56 · 80 · 160
  - KAFJ253K56 · 80 · 160
- 10.4 Replacement long-life filter
  - KAFJ251K56 · 80 · 160
- 10.5 Filter chamber for bottom suction
  - KAJ25K56D · 80D · 160D
- 10.6 Filter chamber for rear suction
  - KAJ25K56B · 80B · 160B
- 10.7 Canvas duct
  - KSAJ25K56 · 80 · 160