

SPLIT TYPE
ROOM AIR CONDITIONER
WALL MOUNTED TYPE

SERVICE MANUAL



Indoor unit	Outdoor unit
ASYG07LECA	AOYG07LEC
ASYG09LECA	AOYG09LEC

CONTENTS

SPECIFICATIONS.....	1
DIMENSIONS.....	2
REFRIGERANT SYSTEM DIAGRAM... .	3
CIRCUIT DIAGRAM.....	4
INDOOR PCB CIRCUIT DIAGRAM.....	5
OUTDOOR PCB CIRCUIT DIAGRAM... .	9
ERROR DETECTION.....	11
PARTS (INDOOR UNIT).....	13
PARTS (OUTDOOR UNIT).....	17
ACCESSORIES.....	20

SPECIFICATIONS

ELECTRICAL DATA

TYPE		Cool & heat inverter	
INDOOR UNIT		ASYG07LECA	ASYG09LECA
OUTDOOR UNIT		AOYG07LEC	AOYG09LEC
COOLING CAPACITY		2.10 kW	2.50 kW
HEATING CAPACITY		3.00 kW	3.20 kW
POWER SOURCE		230 V	230 V
FREQUENCY		50 Hz	50 Hz
RUNNING CURRENT	Cooling	2.7 A	3.5 A
	Heating	3.5 A	3.8 A
INPUT WATTS	Cooling	0.470 kW	0.640 kW
	Heating	0.685 kW	0.750 kW
E.E.R.	Cooling	4.47 kW/kW	3.91 kW/kW
COP	Heating	4.38 kW/kW	4.27 kW/kW
MOISTURE REMOVAL		1.3 L/h	
AIR CIRCULATION HIGH	Cooling	690 m ³ /h	
	Heating	710 m ³ /h	
MAXIMUM CURRENT	Cooling	6.0 A	
	Heating	7.5 A	

FAN MOTOR

POWER SOURCE		230 V
INDOOR UNIT Cooling	High speed	1,400 r.p.m.
	Middle speed	1,200 r.p.m.
	Low speed	920 r.p.m.
	Quiet	620 r.p.m.
INDOOR UNIT Heating	High speed	1,440 r.p.m.
	Middle speed	1,200 r.p.m.
	Low speed	980 r.p.m.
	Quiet	670 r.p.m.
OUTDOOR UNIT Cooling		730 r.p.m.
OUTDOOR UNIT Heating		650 r.p.m.

NOISE LEVEL

INDOOR UNIT Cooling	High speed	43 dB
	Middle speed	38 dB
	Low speed	31 dB
	Quiet	21 dB
INDOOR UNIT Heating	High speed	43 dB
	Middle speed	38 dB
	Low speed	31 dB
	Quiet	21 dB
OUTDOOR UNIT Cooling		45 dB
OUTDOOR UNIT Heating		45 dB

COMPRESSOR AND REFRIGERANT

COMPRESSOR TYPE	Hermetic type, 4 pole, 3 phase, DC inverter motor, Rotary	
DISCRIMINATION	5SS072XAA	
WEIGHT (with oil)	5.9 kg	
PRECHARGED REFRIGERANT	650 g	
REFRIGERANT TYPE	R410A	
FULL CHARGE	Pipe length 15 m	650 g
	20 m	750 g
ADDITIONAL REFRIGERANT	20 g/m	
MAXIMUM PIPING HEIGHT	15m	

DIMENSIONS

INDOOR UNIT	H x W x D	260 x 790 x 198 mm
OUTDOOR UNIT	H x W x D	540 x 660 x 290 mm

WEIGHT

INDOOR UNIT	Shipping / Net	9.5 kg / 7.5 kg
OUTDOOR UNIT	Shipping / Net	26 kg / 23 kg

DIMENSIONS

unit : mm

INDOOR UNIT

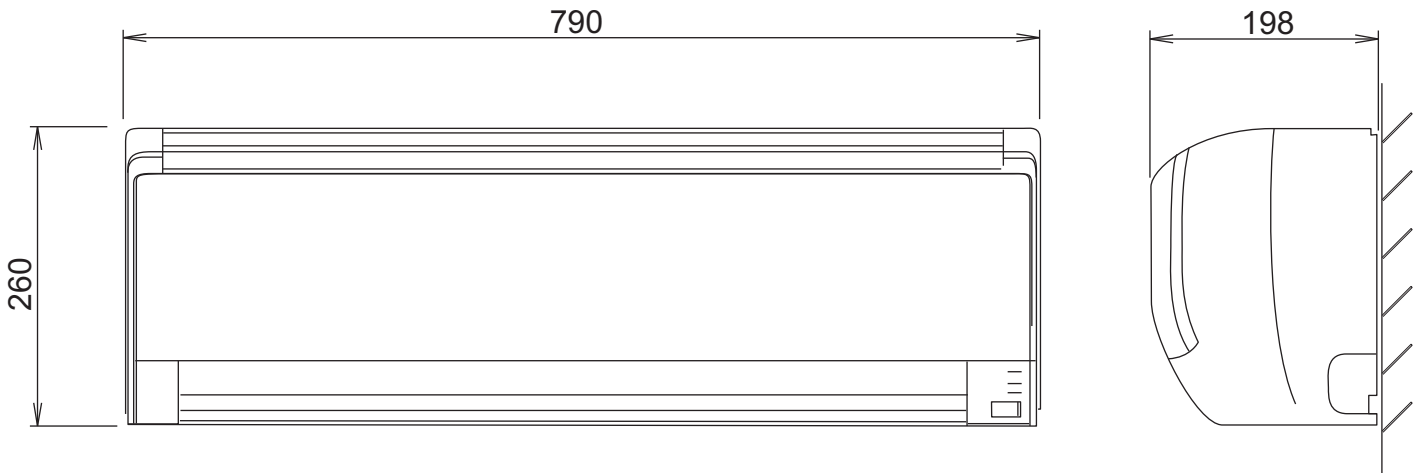

Drain pipe diameter
16.2 mm

Liquid pipe diameter : 6.35 mm
Gas pipe diameter : 9.52 mm

OUTDOOR UNIT

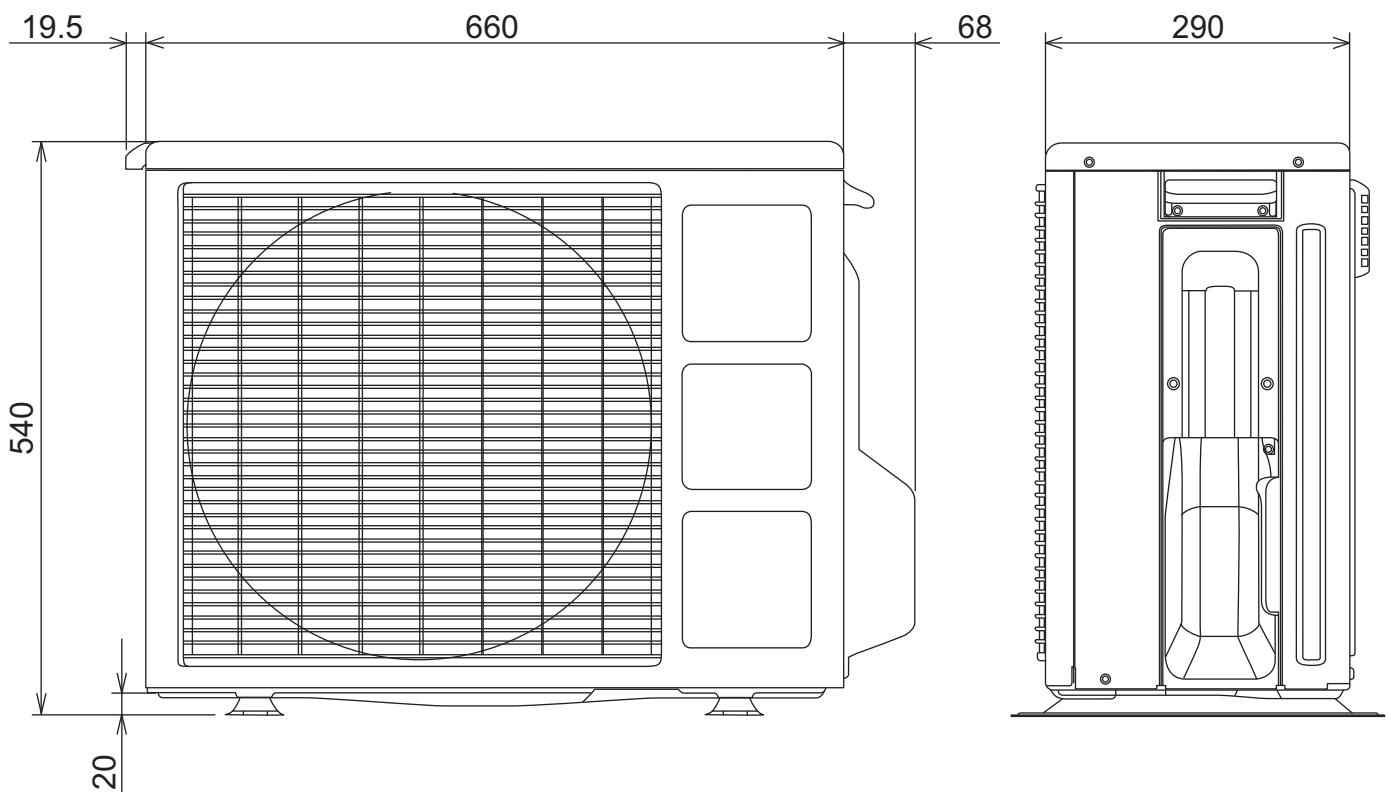

REFRIGERANT SYSTEM DIAGRAM

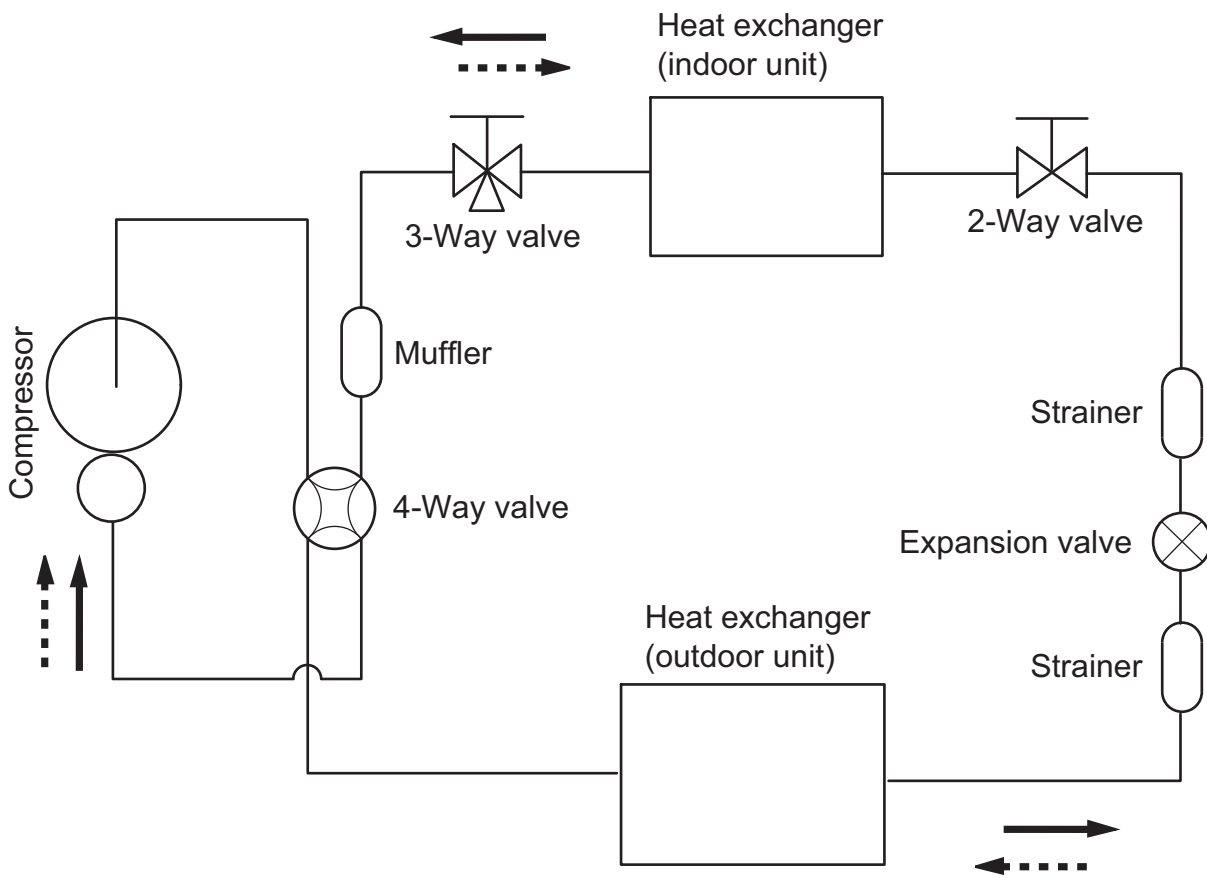

Refrigerant direction

- Cooling
- - - - → Heating

Refrigerant pipe diameter

- Liquid : 1/4" (6.35 mm)
- Gas : 3/8" (9.52 mm)

INDOOR PCB CIRCUIT DIAGRAM

CONTROL UNIT
 ASYG07LECA : EZ-0101SHSE
 ASYG09LECA : EZ-0101THSE

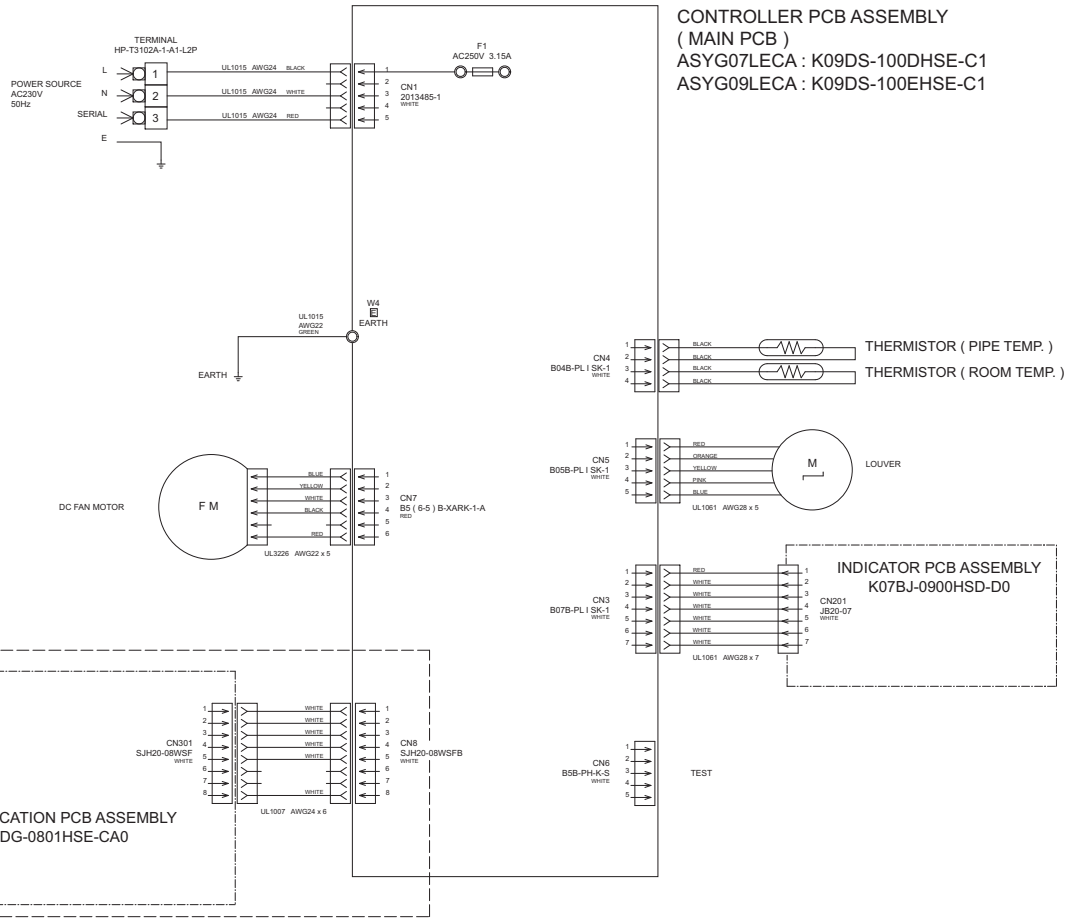

OPTION

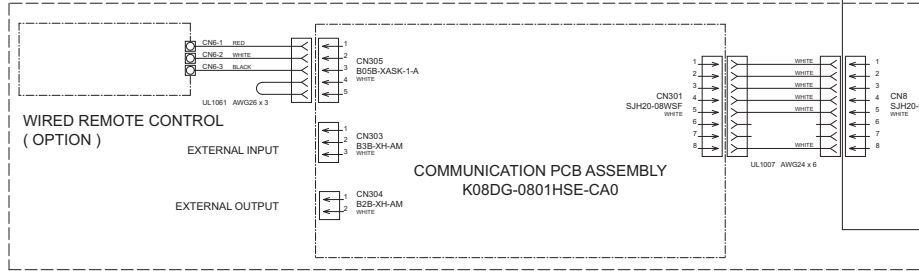

INDOOR UNIT
 CONTROLLER PCB ASSEMBLY (MAIN PCB)
 ASYG07LECA : K09DS-100DHSE-C1
 ASYG09LECA : K09DS-100EHSE-C1

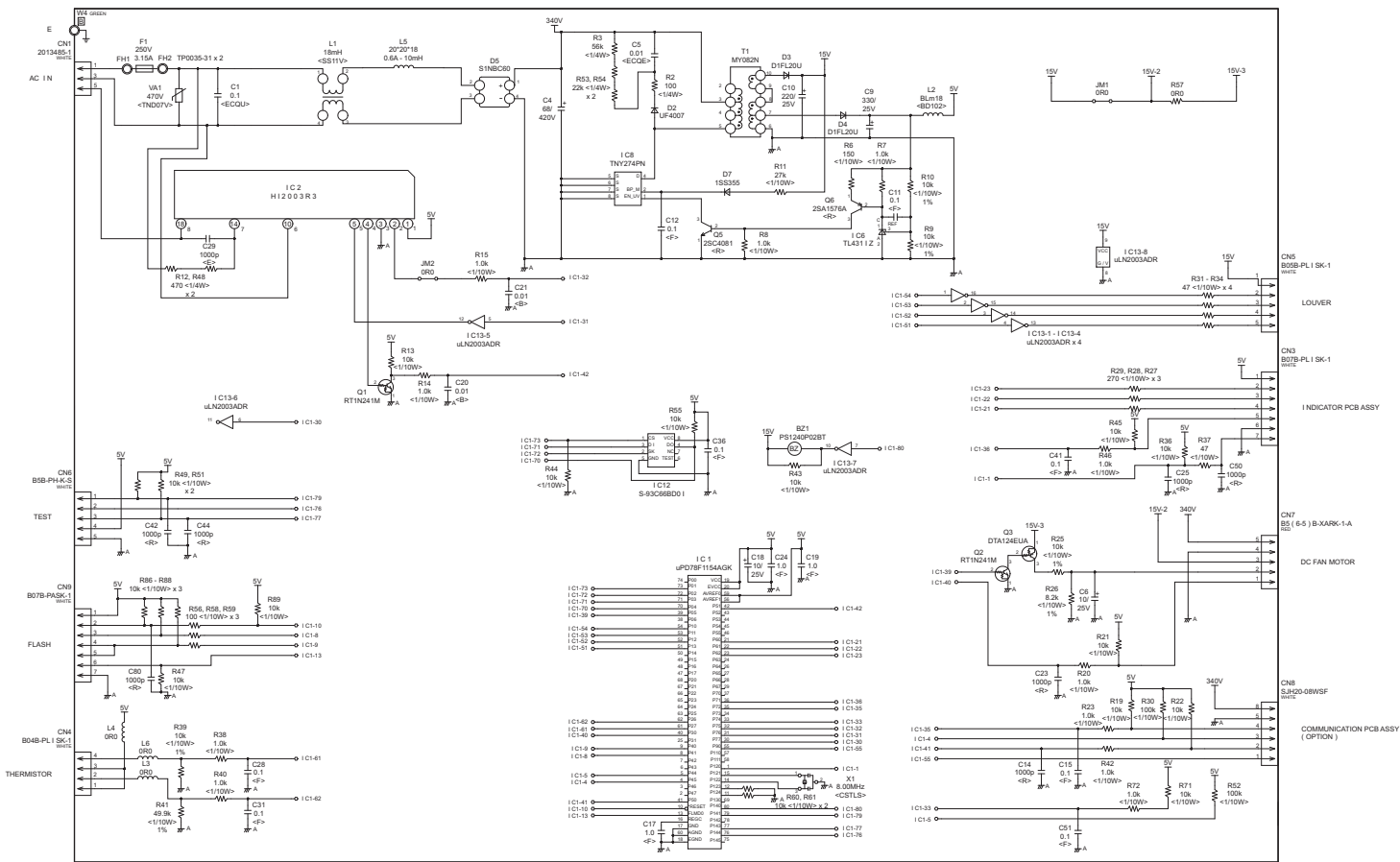

INDOOR UNIT
 INDICATOR PCB ASSEMBLY
 K07BJ-0900HSD-D0

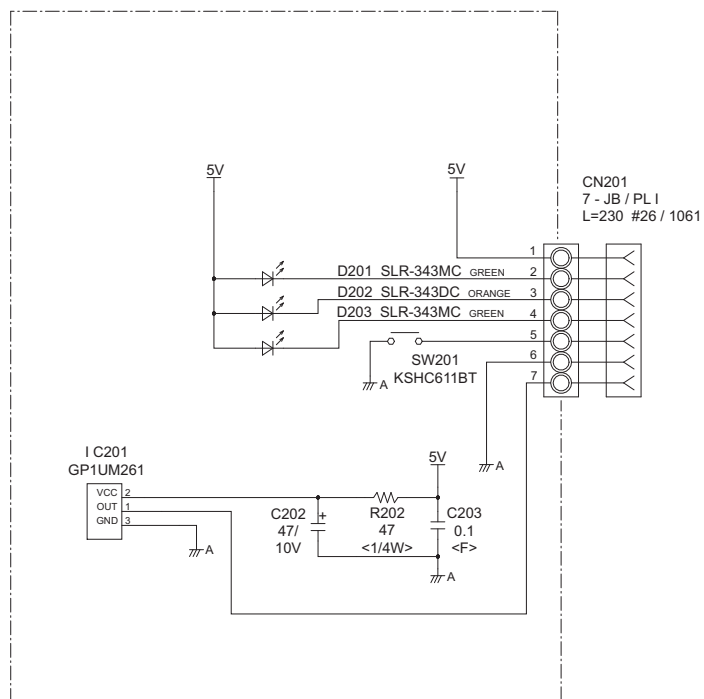

TO CONTROLLER
PCB ASSEMBLY

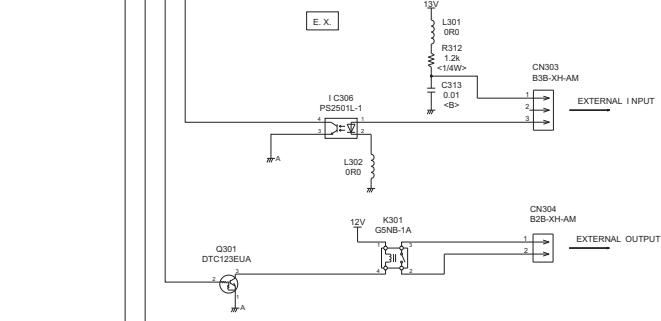
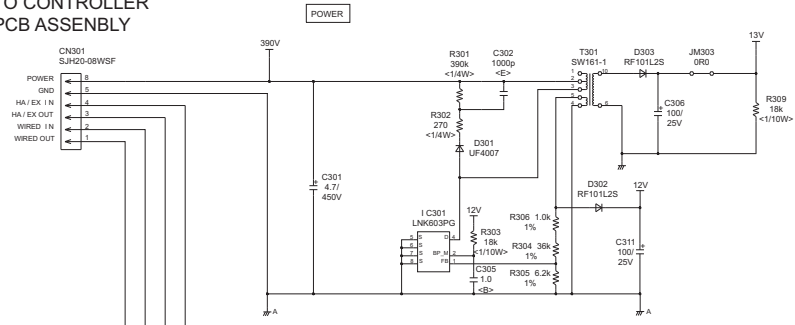

Model : UTY-XCBXE
COMMUNICATION PCB ASSEMBLY
K08DG-0801HSE-CA0

WIRED REMOTE CONTROL UNIT

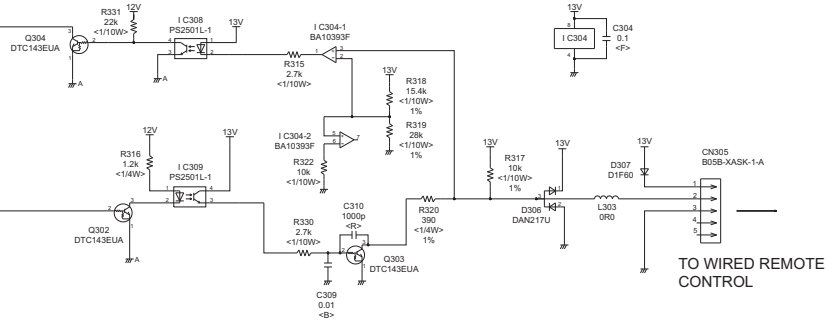

TO WIRED REMOTE CONTROL

OUTDOOR PCB CIRCUIT DIAGRAM

INVERTER ASSEMBLY
 AOYG07LEC : EZ-0100HHUE
 AOYG09LEC : EZ-0100KHUE

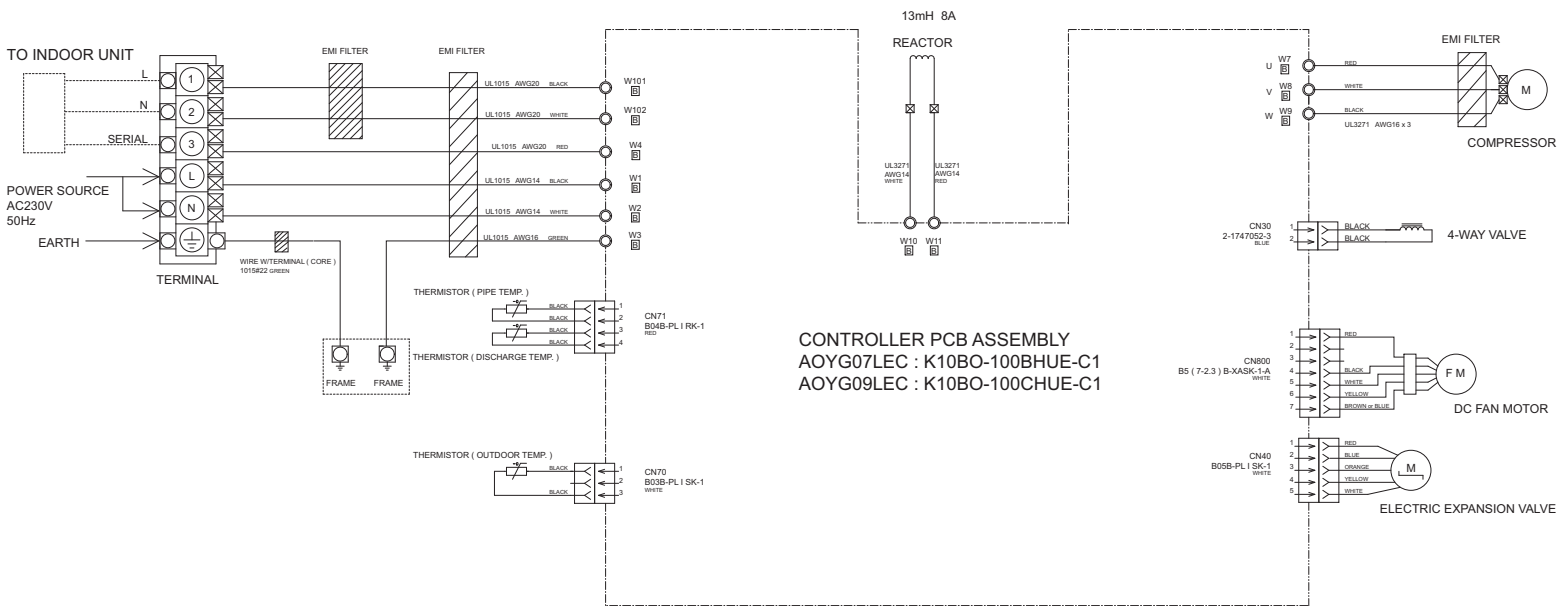

OUTDOOR UNIT
 CONTROLLER PCB ASSEMBLY
 AOYG07LEC : K10BO-100BHUE-C1
 AOYG09LEC : K10BO-100CHUE-C1

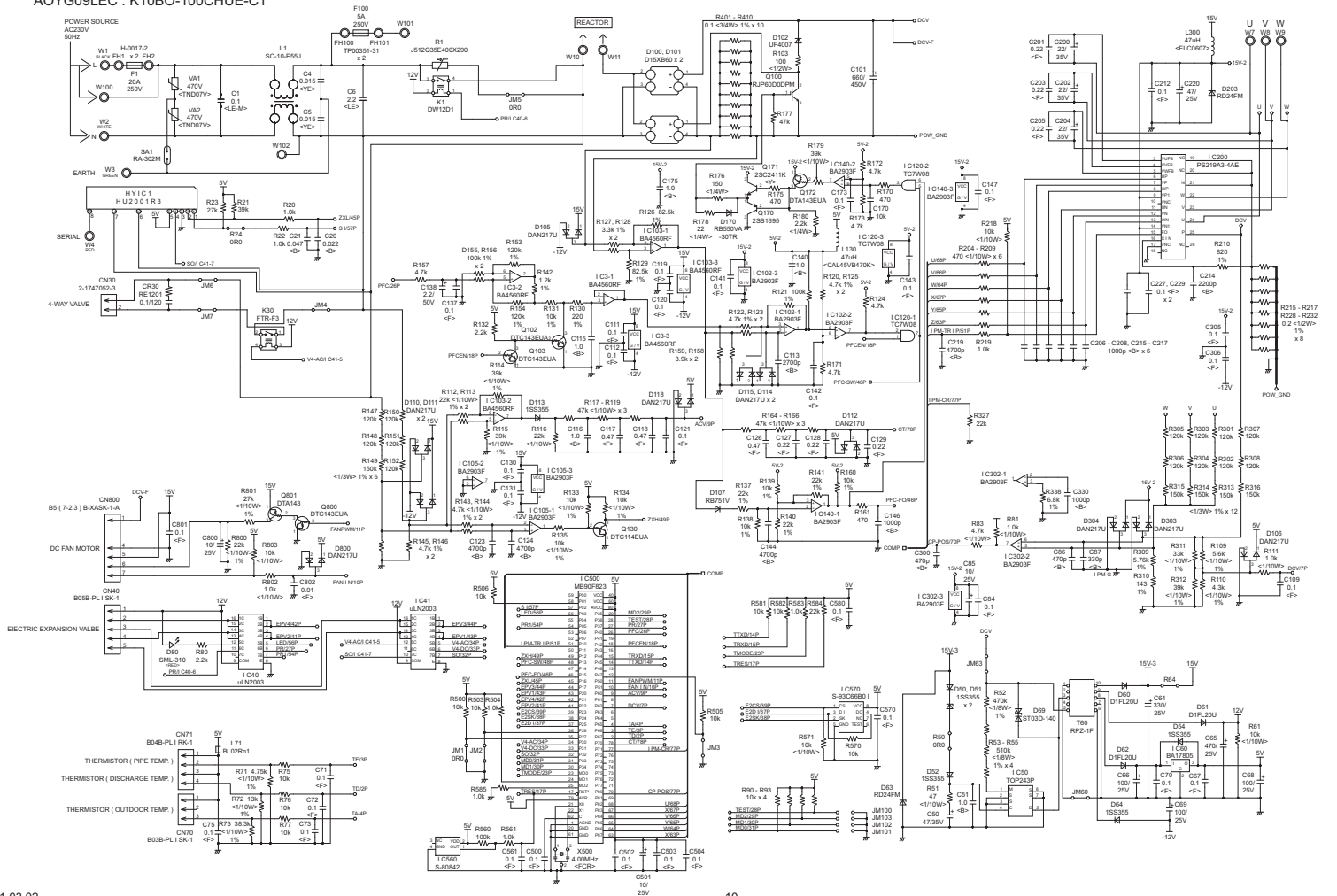

ERROR DETECTION

INDOOR UNIT REMOTE CONTROL

If you use a wireless remote control, the lamp on the photo detector unit will output error codes by way of blinking patterns.

If you use a wired remote control, error codes will appear on the remote control display.

See the lamp blinking patterns and error codes in the table.

An error display is displayed only during operation.

● : 0.5s ON / 0.5s OFF

◇ : 0.1s ON / 0.1s OFF

() : Number of flashing

Indoor unit display

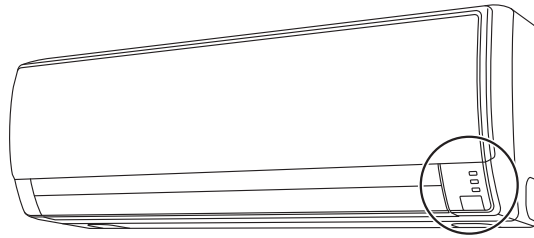

OPERATION OPERATION lamp (green)
TIMER TIMER lamp (orange)
ECONOMY ECONOMY lamp (green)

Wired remote control display (Option)

If an error occurs, the following display will be shown. ("Er" will appear in the set room temperature display.)

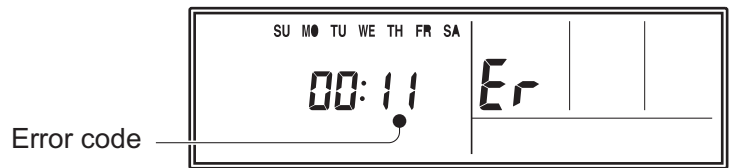

Error code

Indoor unit			Wired remote control	Description
OPERATION lamp (green)	TIMER lamp (orange)	ECONOMY lamp (green)		
● (1)	● (1)	◇	11	Serial communication error
● (1)	● (2)	◇	12	Wired remote control communication error
● (1)	● (5)	◇	15	Check run unfinished
● (2)	● (2)	◇	22	Indoor unit capacity error
● (2)	● (3)	◇	23	Combination error
● (3)	● (2)	◇	32	Indoor unit PCB model information error
● (3)	● (5)	◇	35	Manual auto switch error
● (4)	● (1)	◇	41	Room temp. sensor error
● (4)	● (2)	◇	42	Indoor unit Heat Ex. Middle temp. sensor error
● (5)	● (1)	◇	51	Indoor unit fan motor error
● (5)	● (3)	◇	53	Drain pump error
● (5)	● (7)	◇	57	Damper error
● (5)	● (15)	◇	5U	Indoor unit error
● (6)	● (2)	◇	62	Outdoor unit main PCB model information error or communication error
● (6)	● (3)	◇	63	Inverter error
● (6)	● (4)	◇	64	Active filter error, PFC circuit error
● (6)	● (5)	◇	65	Trip terminal L error
● (6)	● (10)	◇	6A	Display PCB microcomputers communication error
● (7)	● (1)	◇	71	Discharge temp. sensor error

Indoor unit			Wired remote control	Description
OPERATION lamp (green)	TIMER lamp (orange)	ECONOMY lamp (green)		
● (7)	● (2)	◇	72	Compressor temp. sensor error
● (7)	● (3)	◇	73	Outdoor unit Heat Ex. liquid temp. sensor error
● (7)	● (4)	◇	74	Outdoor temp. sensor error
● (7)	● (5)	◇	75	Suction Gas temp. sensor error
● (7)	● (6)	◇	76	• 2-way valve temp. sensor error • 3-way valve temp. sensor error
● (7)	● (7)	◇	77	Heat sink temp. sensor error
● (8)	● (2)	◇	82	• Sub-cool Heat Ex. gas inlet temp. sensor error • Sub-cool Heat Ex. gas outlet temp. sensor error
● (8)	● (3)	◇	83	Liquid pipe temp. sensor error
● (8)	● (4)	◇	84	Current sensor error
● (8)	● (6)	◇	86	• Discharge pressure sensor error • Suction pressure sensor error • High pressure switch error
● (9)	● (4)	◇	94	Trip detection
● (9)	● (5)	◇	95	Compressor rotor position detection error (permanent stop)
● (9)	● (7)	◇	97	Outdoor unit fan motor error
● (9)	● (9)	◇	99	4-way valve error
● (10)	● (1)	◇	A1	Discharge temp. error
● (10)	● (3)	◇	A3	Compressor temp. error
● (10)	● (4)	◇	A4	High pressure error
● (10)	● (5)	◇	A5	Low pressure error

OUTDOOR UNIT

LED	ERROR
on	Discharge temperature abnormal
0.5 second on / 0.5 second off	IPM overcurrent protection
0.1 second on / 0.1 second off	Thermistor abnormal
2.0 second on / 2.0 second off	CT abnormal
0.1 second on / 2.0 second off	Compressor location abnormal
5.0 second on / 5.0 second off	Fan abnormal

PARTS

INDOOR UNIT
Front panel

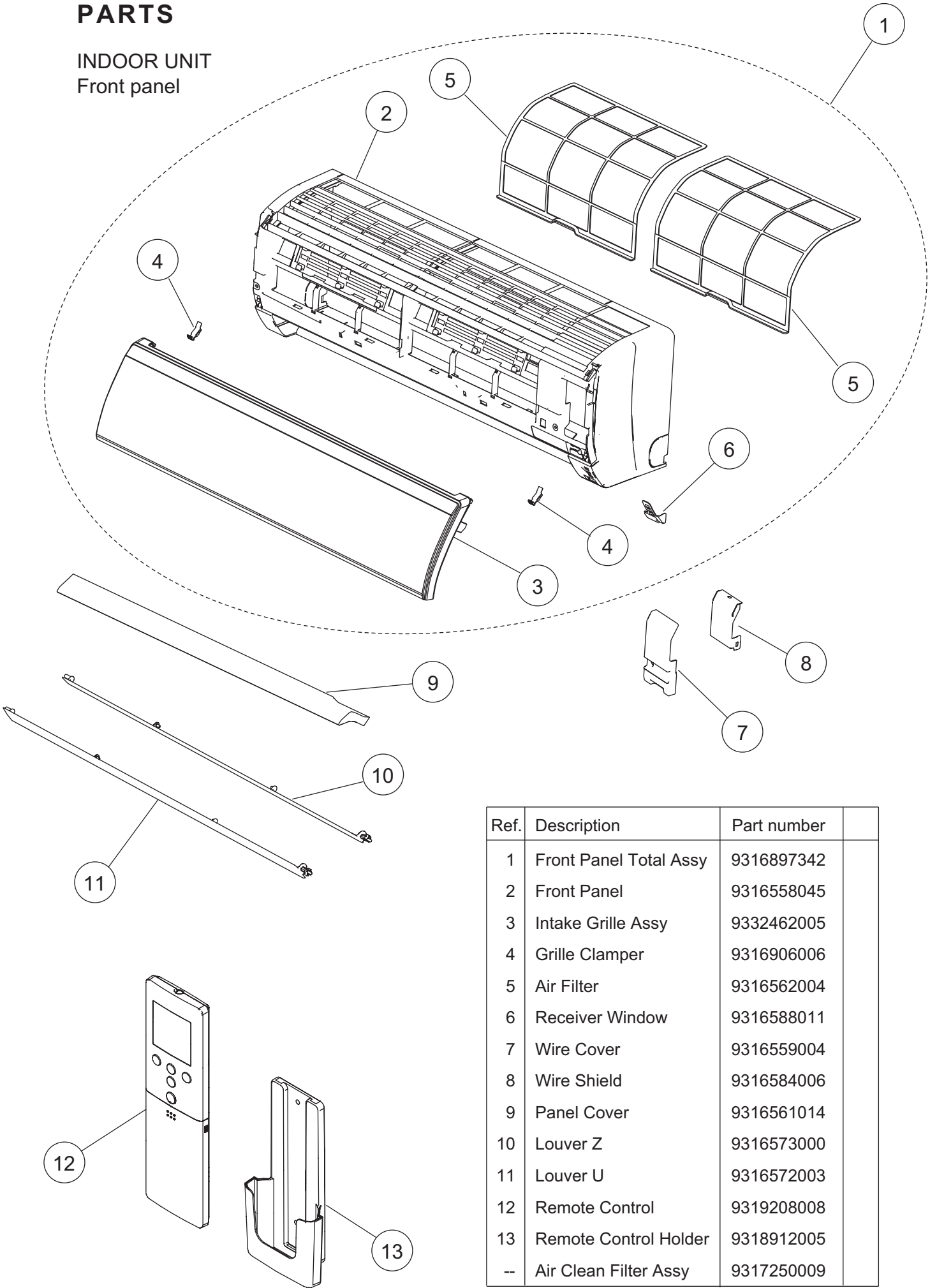

Ref.	Description	Part number
1	Front Panel Total Assy	9316897342
2	Front Panel	9316558045
3	Intake Grille Assy	9332462005
4	Grille Clamper	9316906006
5	Air Filter	9316562004
6	Receiver Window	9316588011
7	Wire Cover	9316559004
8	Wire Shield	9316584006
9	Panel Cover	9316561014
10	Louver Z	9316573000
11	Louver U	9316572003
12	Remote Control	9319208008
13	Remote Control Holder	9318912005
--	Air Clean Filter Assy	9317250009

INDOOR UNIT
Casing assy

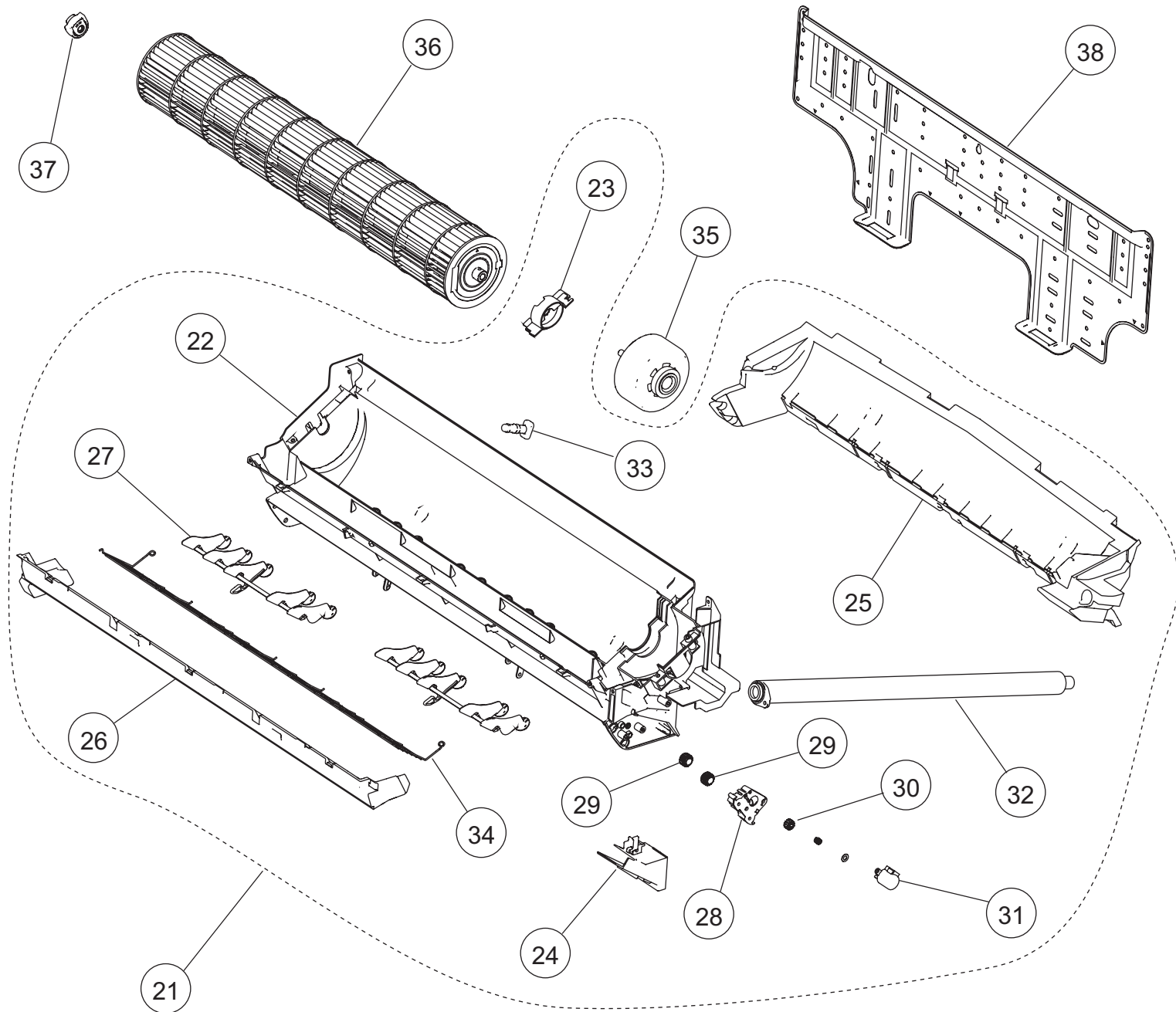

Ref.	Description	Part number
21	Casing Assy	9316892095
22	Casing	9316563001
23	Motor Cover	9316568006
24	Cable Guide	9316567009
25	Casing Cover B	9316569003
26	Casing Cover F	9316570009
27	R and L Louver B	9316961005
28	Louver Gear Holder	9316575004
29	Louver Gear	9316574007

Ref.	Description	Part number
30	Gear A	9309994003
31	Motor Step	9900139193
32	Drain Hose Assy	9316904002
33	Drain Cap	9316177017
34	Fan Guard	9317182003
35	Fan Motor	9603100001
36	Crossflow Fan Assy	9316830004
37	Shaft Holder C	9306628017
38	Bracket Panel	9316590007

INDOOR UNIT
Control box

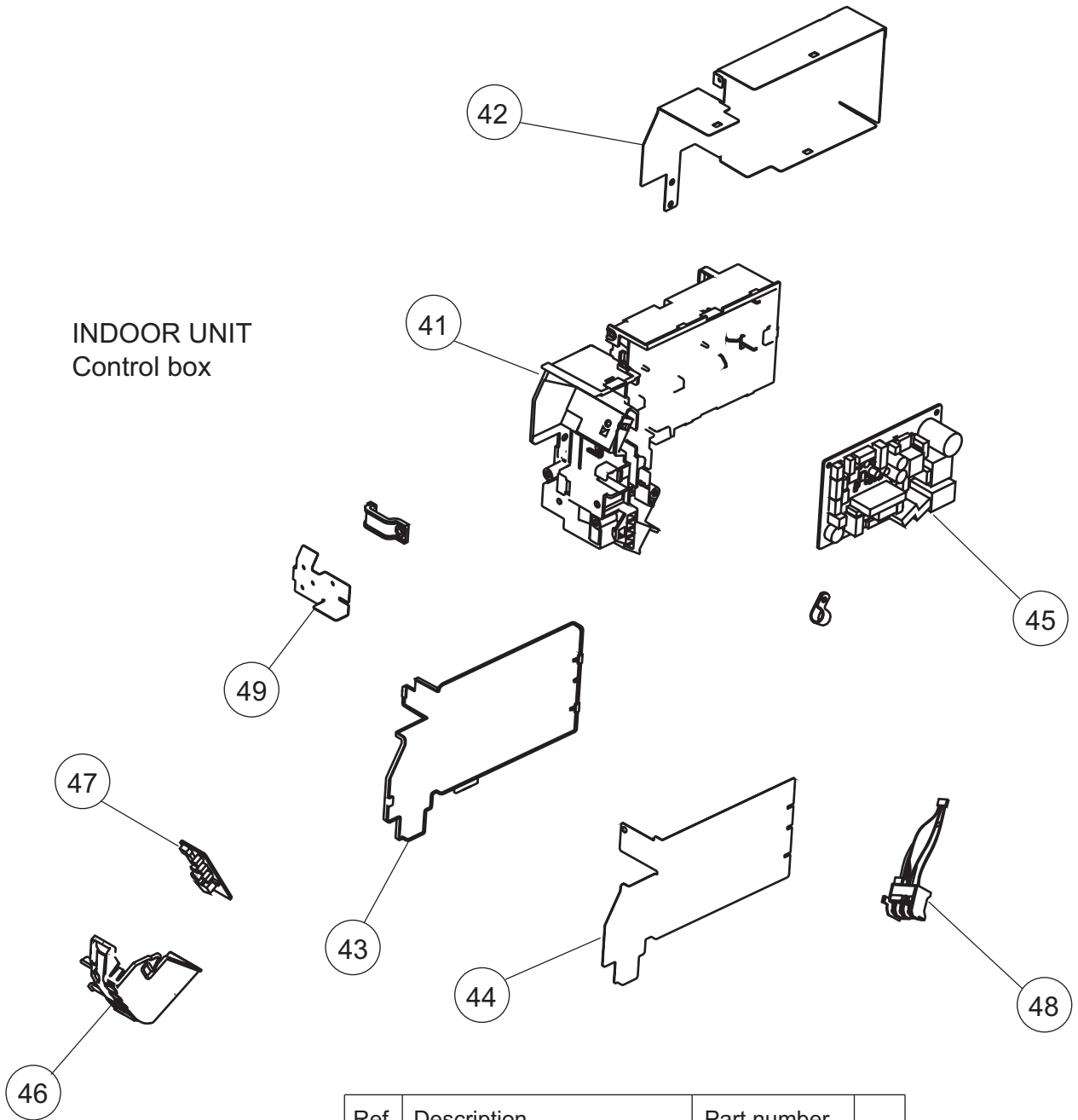

Ref.	Description	Part number
41	Control Box	9316582002
42	Box Shield	9316580008
43	Control Cover	9316583009
44	Cover Shield	9316581005
45	Controller PCB Assy (07)	9708536156
45	Controller PCB Assy (09)	9708536163
46	Display Case	9316587007
47	Display PCB Assy	9707649024
48	Terminal	9900638009
49	Earth Terminal	9316586000
--	Thermistor Assy	9900563004

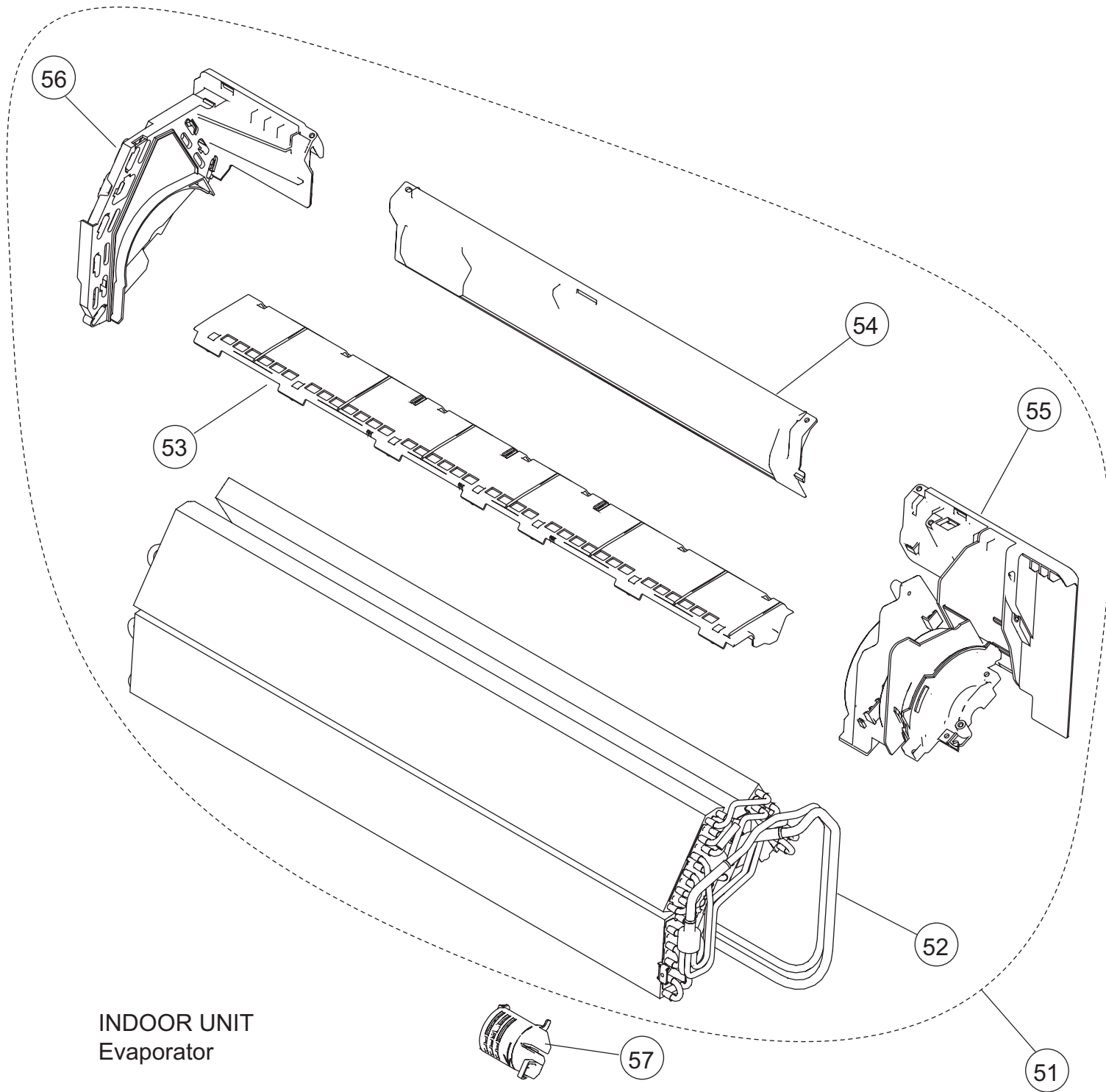

INDOOR UNIT
Evaporator

Ref.	Description	Part number
51	Evaporator Total Assy	9316893009
52	Joint Pipe Assy	9316923010
53	Filter Guide	9316578005
54	Rear Bracket	9316566019
55	Evaporator Holder R	9316565005
56	Evaporator Holder L	9316564008
57	Room Thermistor Holder	9316895003

PARTS

OUTDOOR UNIT

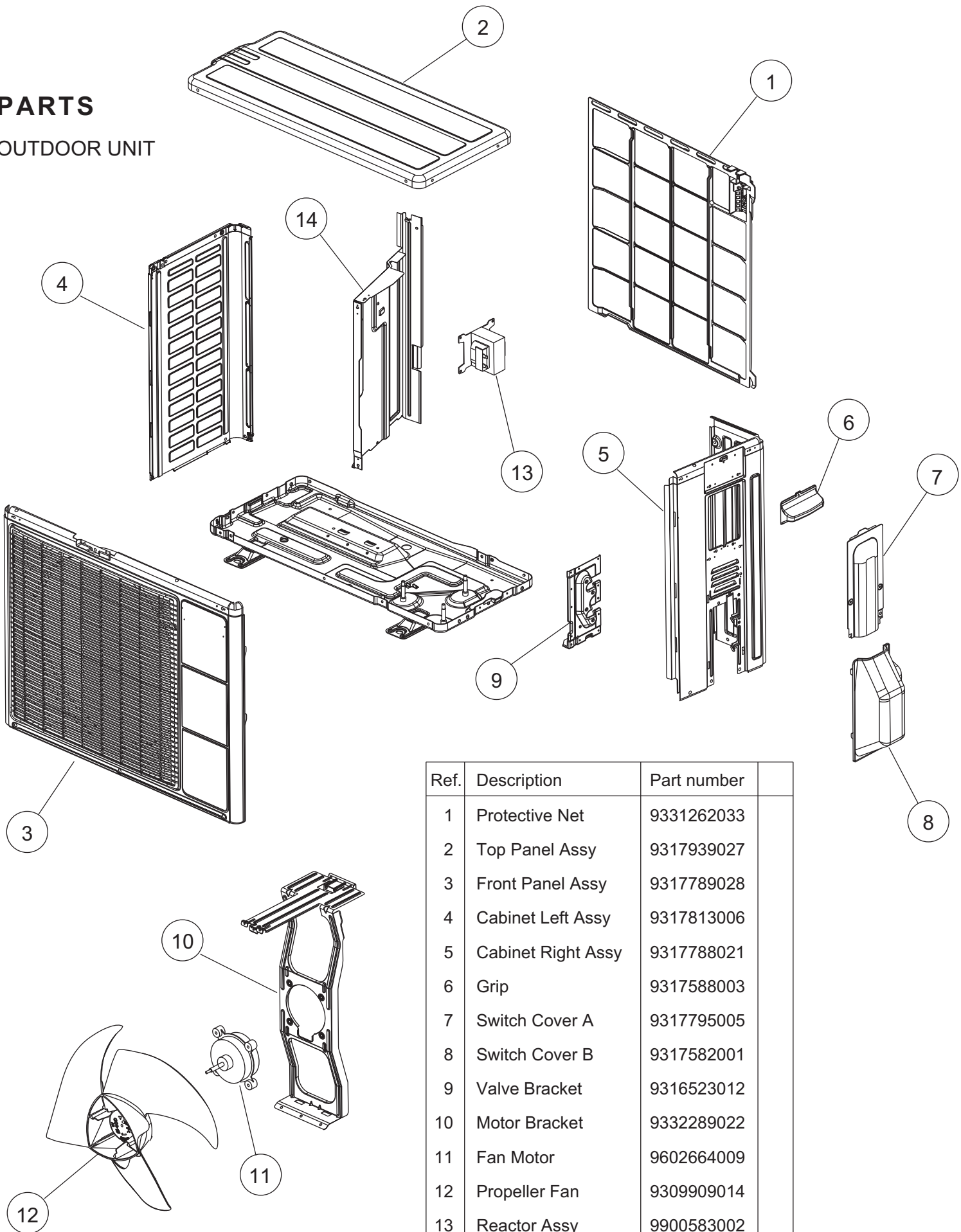

Ref.	Description	Part number
1	Protective Net	9331262033
2	Top Panel Assy	9317939027
3	Front Panel Assy	9317789028
4	Cabinet Left Assy	9317813006
5	Cabinet Right Assy	9317788021
6	Grip	9317588003
7	Switch Cover A	9317795005
8	Switch Cover B	9317582001
9	Valve Bracket	9316523012
10	Motor Bracket	9332289022
11	Fan Motor	9602664009
12	Propeller Fan	9309909014
13	Reactor Assy	9900583002
14	Separator Assy	9317786010
--	Emblem	9319151007
--	Drain Assy	9303029022

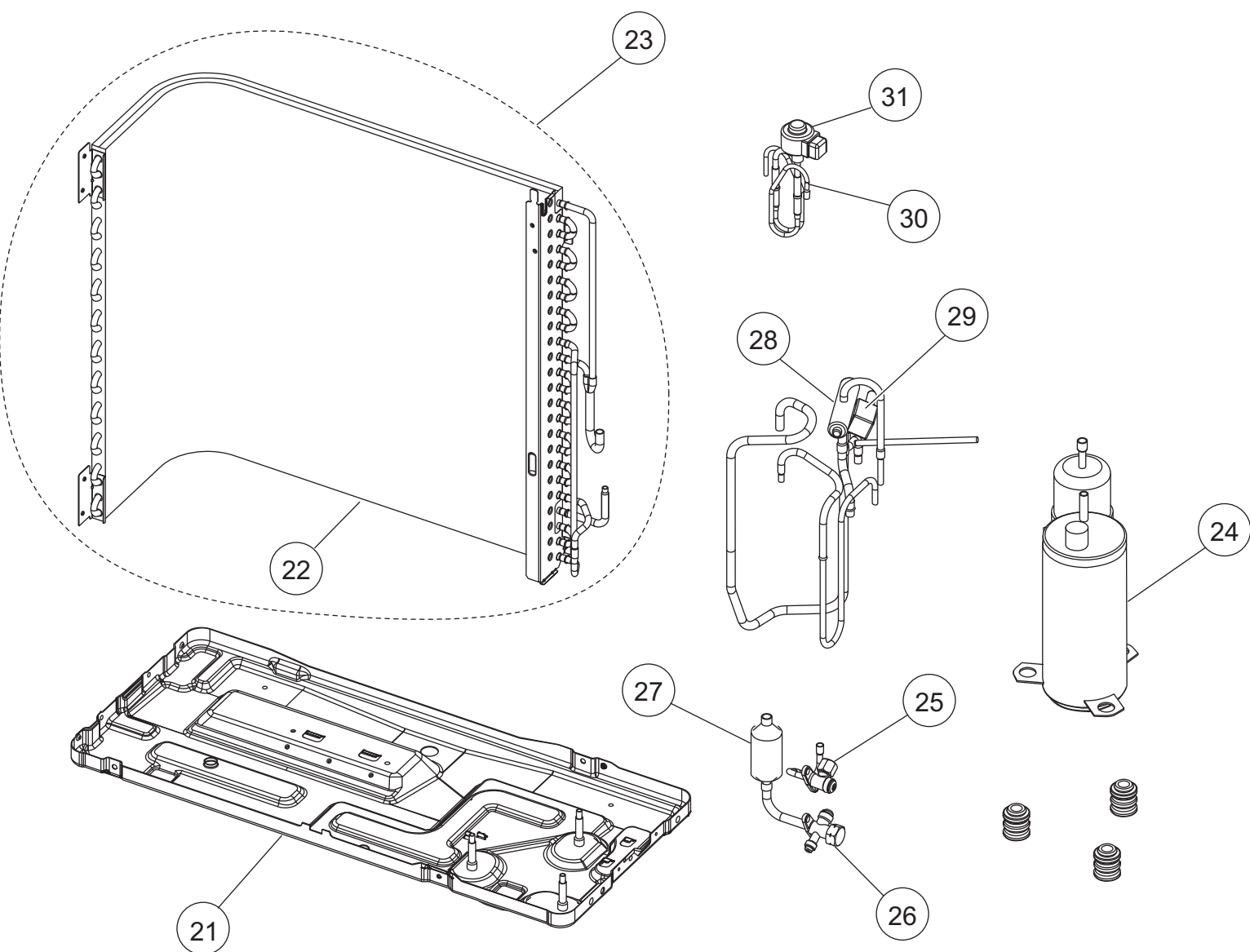

OUTDOOR UNIT



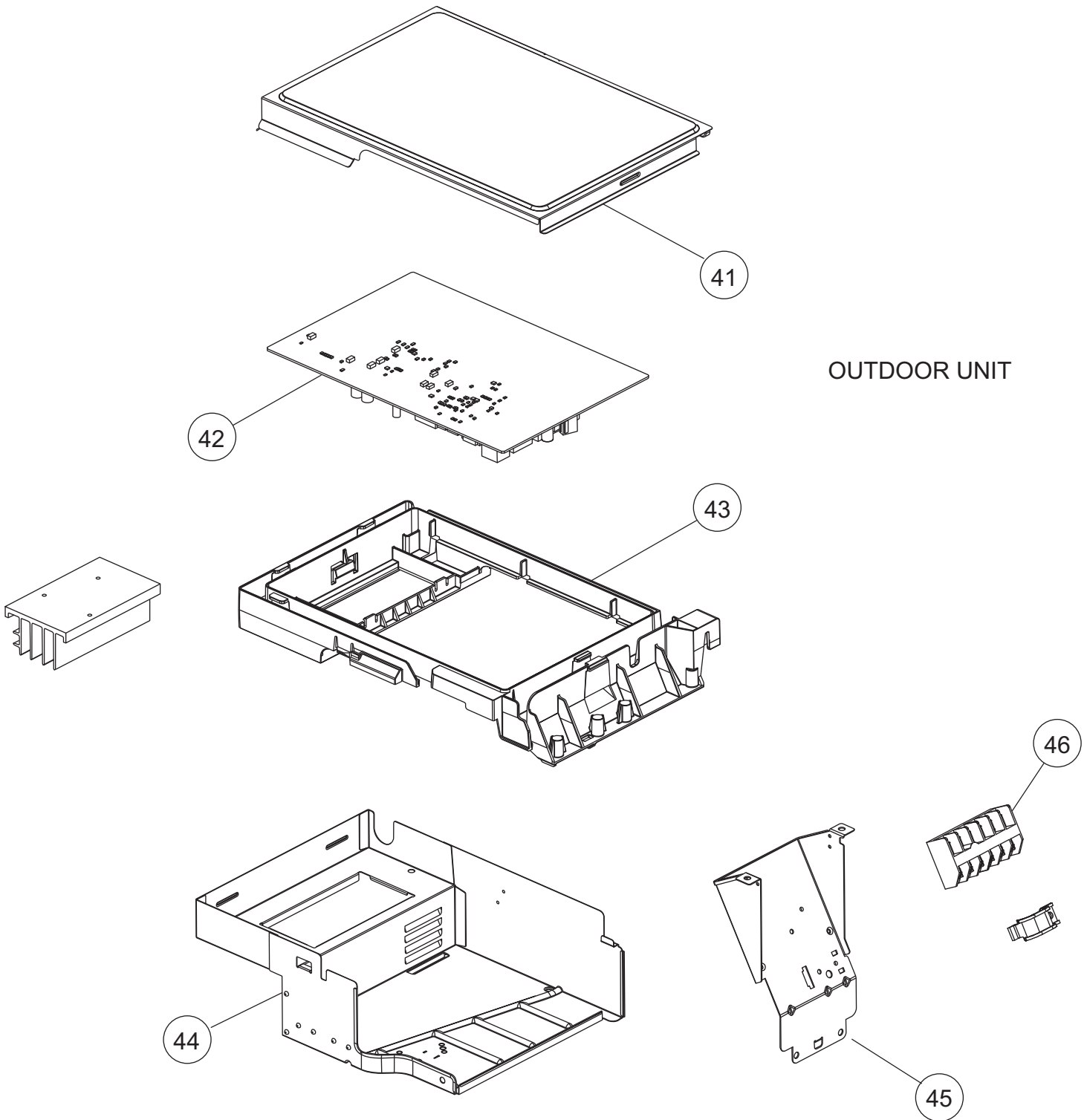

Ref.	Description	Part number
21	Base Assy	9316916029
22	Condenser Assy	9317286008
23	Condenser Total Assy	9317287012
24	Compressor Assy	9317083010
25	2 way Valve Assy	9318252002
26	3 way Valve Assy	9318254006
27	Muffler	9317394000
28	4 way Valve Assy	9317890021
29	Solenoid	9970079023
30	Pulse Motor Valve Assy	9317216036
31	Expansion Valve Coil	9970103025

OUTDOOR UNIT

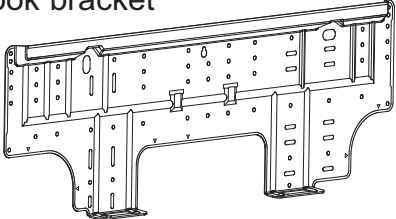
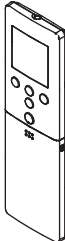

Ref.	Description	Part number
41	Sealed Panel	9318181012
42	Controller PCB Assy (07)	9708683096
42	Controller PCB Assy (09)	9708683102
43	PCB Holder	9318182002
44	Inverter Case Assy	9332247008
45	Terminal Bracket	9317816038
46	Terminal	9900435028
--	Outdoor Thermistor	9900565008
--	Thermistor Assy	9900628000

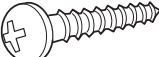
ACCESSORIES

Name and Shape	Part number
Wall hook bracket 	9316590007
Remote control 	9319208008
Remote control holder 	9318912005
Battery (penlight) 	0600185541
Cloth tape 	9310519004
Tapping screw (big) (ϕ 4 x 25) 	0700076046
Tapping screw (small) (ϕ 3 x 12) 	0700019036

OPTION

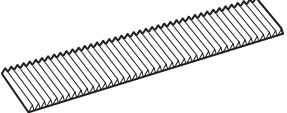
Name and Shape	Part number
Air cleaning filter 	UTR-FA16 UTR-FA16-2

1101G3871