

SPLIT TYPE
ROOM AIR CONDITIONER
WALL MOUNTED TYPE

SERVICE MANUAL



Indoor unit	Outdoor unit
ASYG12LUCA	AOYG12LUC
ASYG14LUCA	AOYG14LUC

CONTENTS

SPECIFICATIONS.....	1
DIMENSIONS.....	2
REFRIGERANT SYSTEM DIAGRAM... ..	3
CIRCUIT DIAGRAM.....	4
INDOOR PCB CIRCUIT DIAGRAM.....	5
OUTDOOR PCB CIRCUIT DIAGRAM... ..	8
ERROR DETECTION.....	10
PARTS (INDOOR UNIT).....	12
PARTS (OUTDOOR UNIT).....	17
ACCESSORIES.....	20

SPECIFICATIONS

ELECTRICAL DATA

TYPE		Cool & heat inverter	
INDOOR UNIT		ASYG12LUCA	ASYG14LUCA
OUTDOOR UNIT		AOYG12LUC	AOYG14LUC
COOLING CAPACITY		3.50 kW	4.20 kW
HEATING CAPACITY		4.00 kW	5.40 kW
POWER SOURCE		230 V	230 V
FREQUENCY		50 Hz	50 Hz
RUNNING CURRENT	Cooling	4.6 A	5.8 A
	Heating	4.7 A	6.3 A
INPUT WATTS	Cooling	0.905 kW	1.235 kW
	Heating	0.930 kW	1.380 kW
E.E.R.	Cooling	3.87 kW/kW	3.40 kW/kW
COP	Heating	4.30 kW/kW	3.91 kW/kW
MOISTURE REMOVAL		1.8 L/h	2.1 L/h
AIR CIRCULATION HIGH	Cooling	850 m ³ /h	900 m ³ /h
	Heating	850 m ³ /h	950 m ³ /h
MAXIMUM CURRENT	Cooling	6.5 A	9.0 A
	Heating	9.0 A	10.5 A

FAN MOTOR

POWER SOURCE		230 V	
INDOOR UNIT Cooling	High speed	1,370 r.p.m.	1,440 r.p.m.
	Middle speed	1,120 r.p.m.	1,220 r.p.m.
	Low speed	960 r.p.m.	980 r.p.m.
	Quiet	650 r.p.m.	740 r.p.m.
INDOOR UNIT Heating	High speed	1,370 r.p.m.	1,510 r.p.m.
	Middle speed	1,180 r.p.m.	1,220 r.p.m.
	Low speed	960 r.p.m.	1,030 r.p.m.
	Quiet	650 r.p.m.	790 r.p.m.
OUTDOOR UNIT Cooling		850 r.p.m.	850 r.p.m.
OUTDOOR UNIT Heating		750 r.p.m.	750 r.p.m.

NOISE LEVEL

INDOOR UNIT Cooling	High speed	43 dB	45 dB
	Middle speed	37 dB	40 dB
	Low speed	32 dB	33 dB
	Quiet	21 dB	25 dB
INDOOR UNIT Heating	High speed	43 dB	45 dB
	Middle speed	38 dB	40 dB
	Low speed	32 dB	34 dB
	Quiet	21 dB	27 dB
OUTDOOR UNIT Cooling		50 dB	50 dB
OUTDOOR UNIT Heating		50 dB	50 dB

COMPRESSOR AND REFRIGERANT

COMPRESSOR TYPE	Hermetic type, 4 pole, 3 phase, DC inverter motor, Rotary	
DISCRIMINATION	DA89X1C-20FZ2	
WEIGHT (with oil)	9.2 kg	
PRECHARGED REFRIGERANT	1,050 g	
REFRIGERANT TYPE	R410A	
FULL CHARGE	Pipe length 15 m	1,050 g
	20 m	1,150 g
ADDITIONAL CHARGE	20 g/m	
MAXIMUM PIPING HEIGHT	15m	

DIMENSIONS

INDOOR UNIT	H x W x D	282 x 870 x 185 mm
OUTDOOR UNIT	H x W x D	540 x 790 x 290 mm

WEIGHT

INDOOR UNIT	Shipping / Net	12 kg / 9.5 kg
OUTDOOR UNIT	Shipping / Net	37 kg / 33 kg / 38 kg / 34 kg

DIMENSIONS

unit : mm

INDOOR UNIT

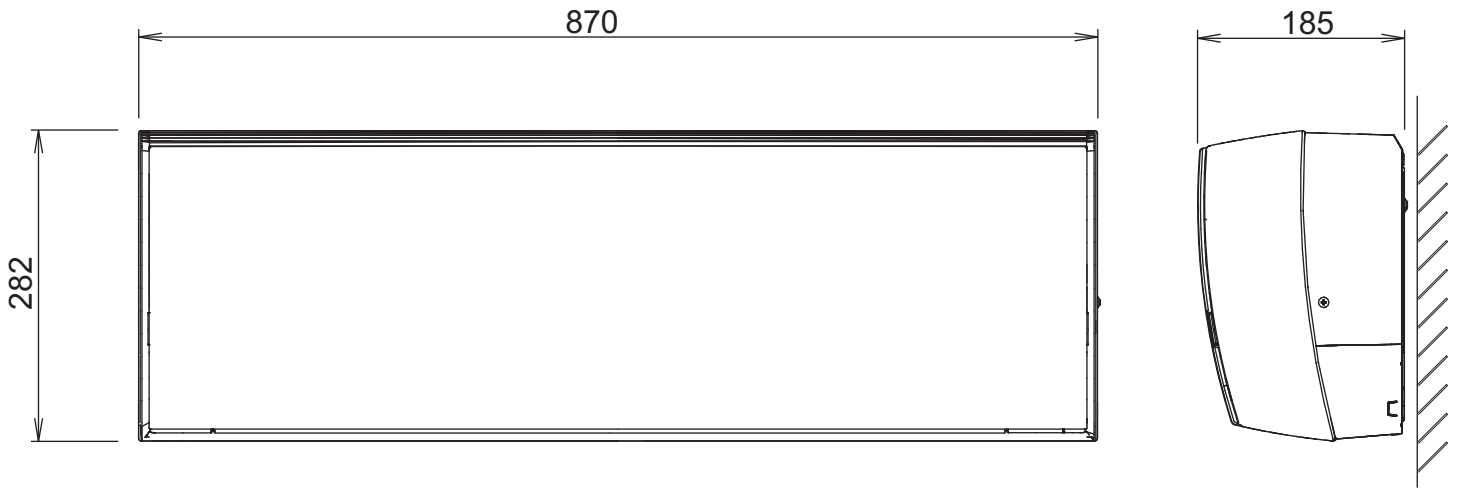

Drain pipe diameter
16.2 mm

Liquid pipe diameter : 6.35 mm
Gas pipe diameter : 9.52 mm

OUTDOOR UNIT

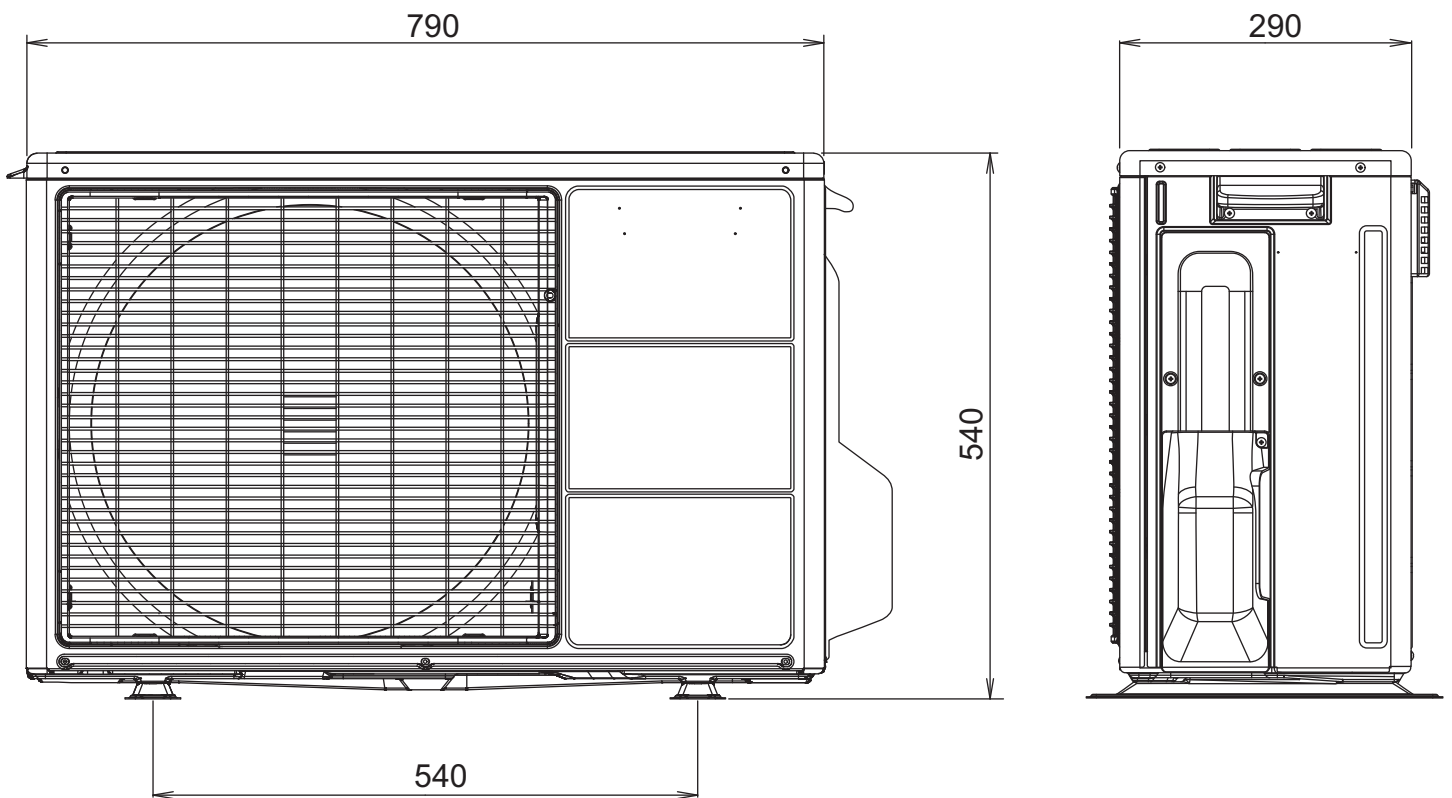

REFRIGERANT SYSTEM DIAGRAM

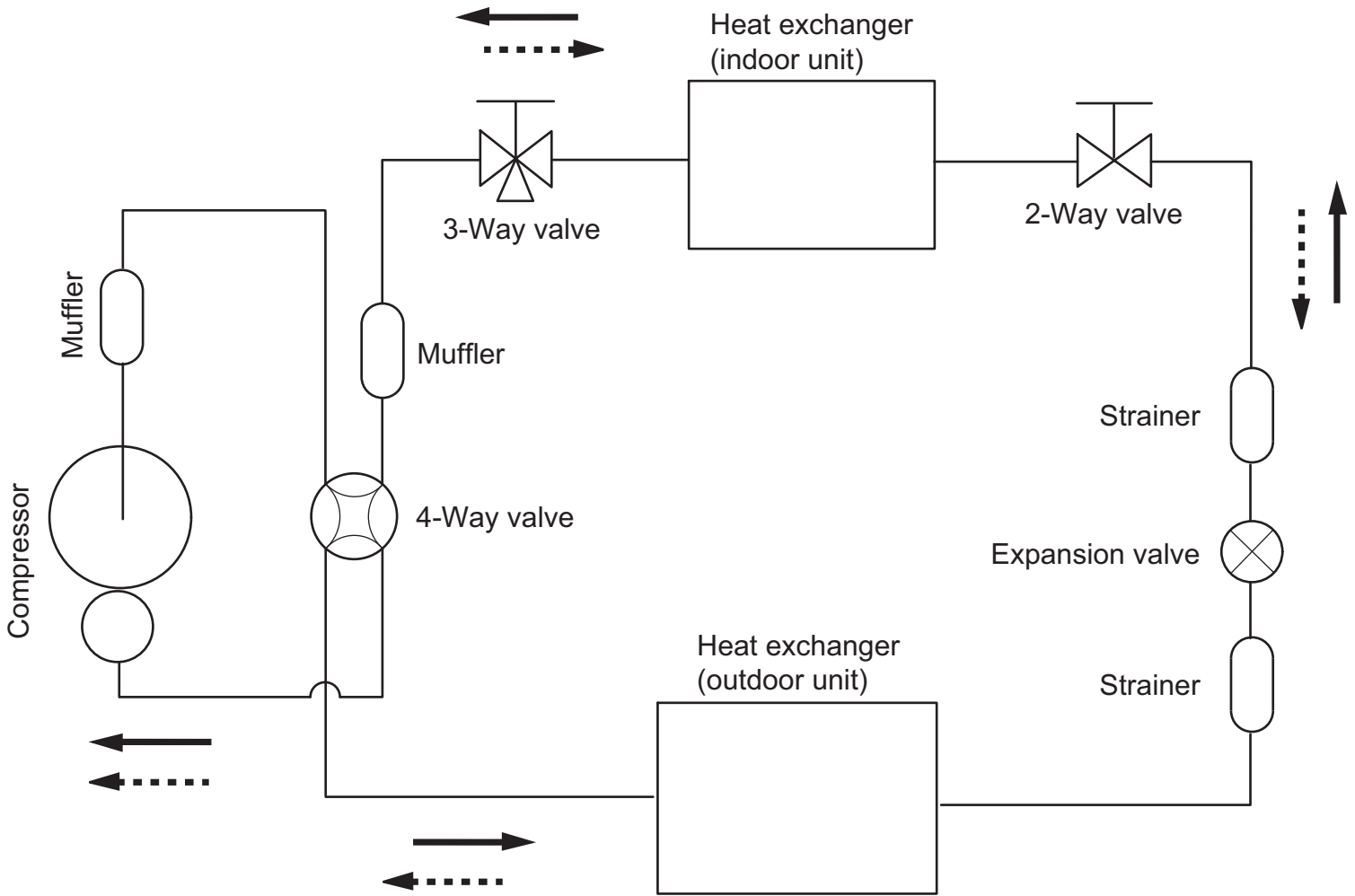

Refrigerant direction

- Cooling
- - - -> Heating

Refrigerant pipe diameter

12

Liquid : 1/4" (6.35 mm)

Gas : 3/8" (9.52 mm)

14

Liquid : 1/4" (6.35 mm)

Gas : 1/2" (12.7 mm)

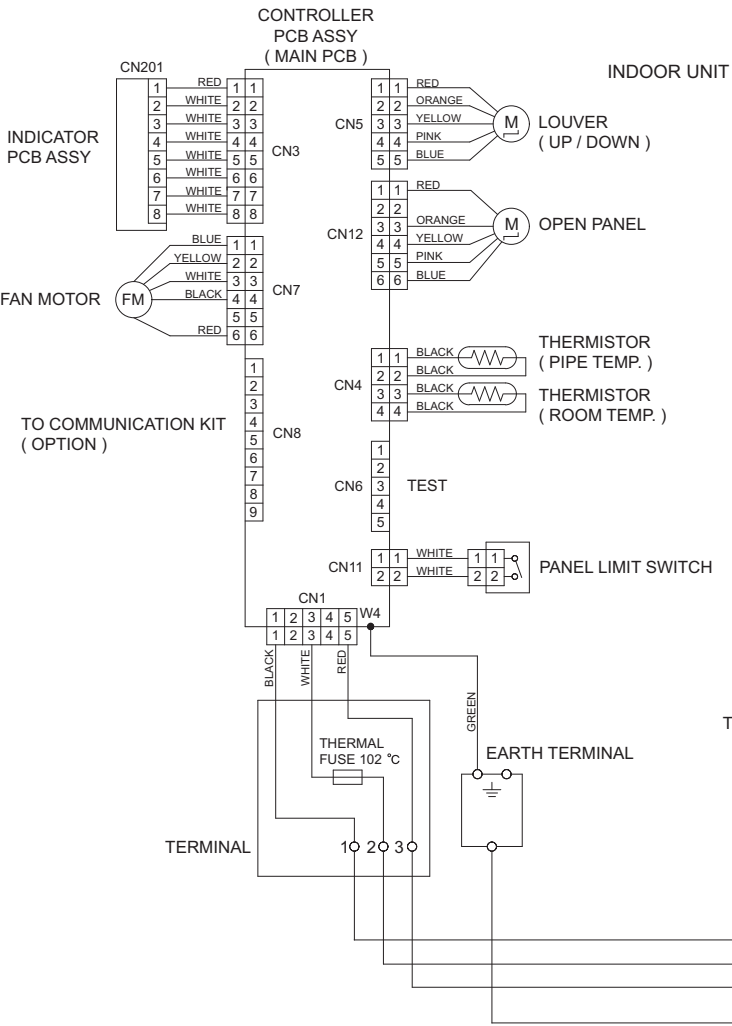

CIRCUIT DIAGRAM

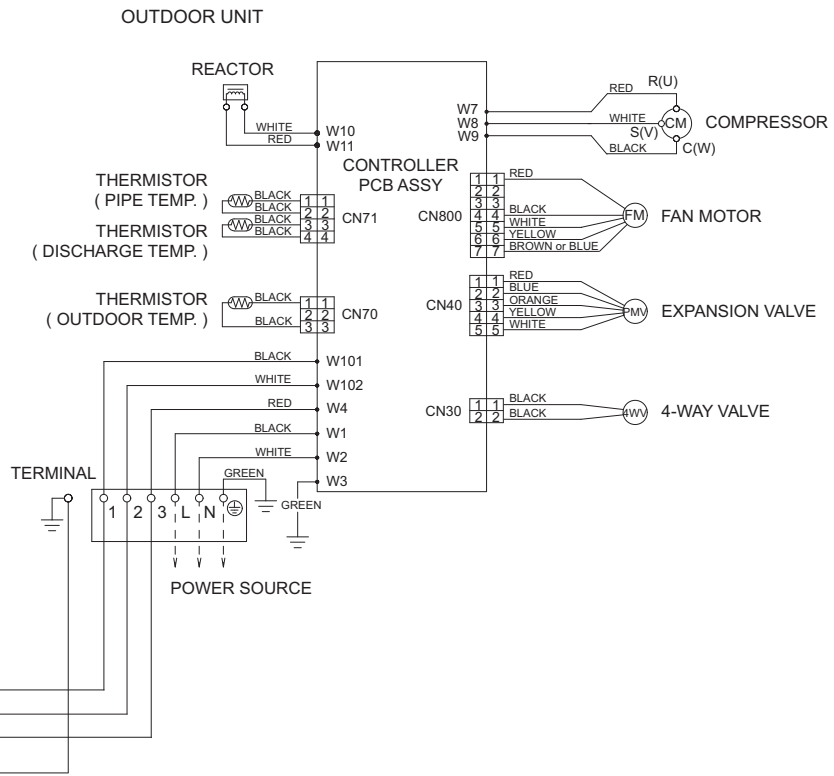

INDOOR PCB CIRCUIT DIAGRAM

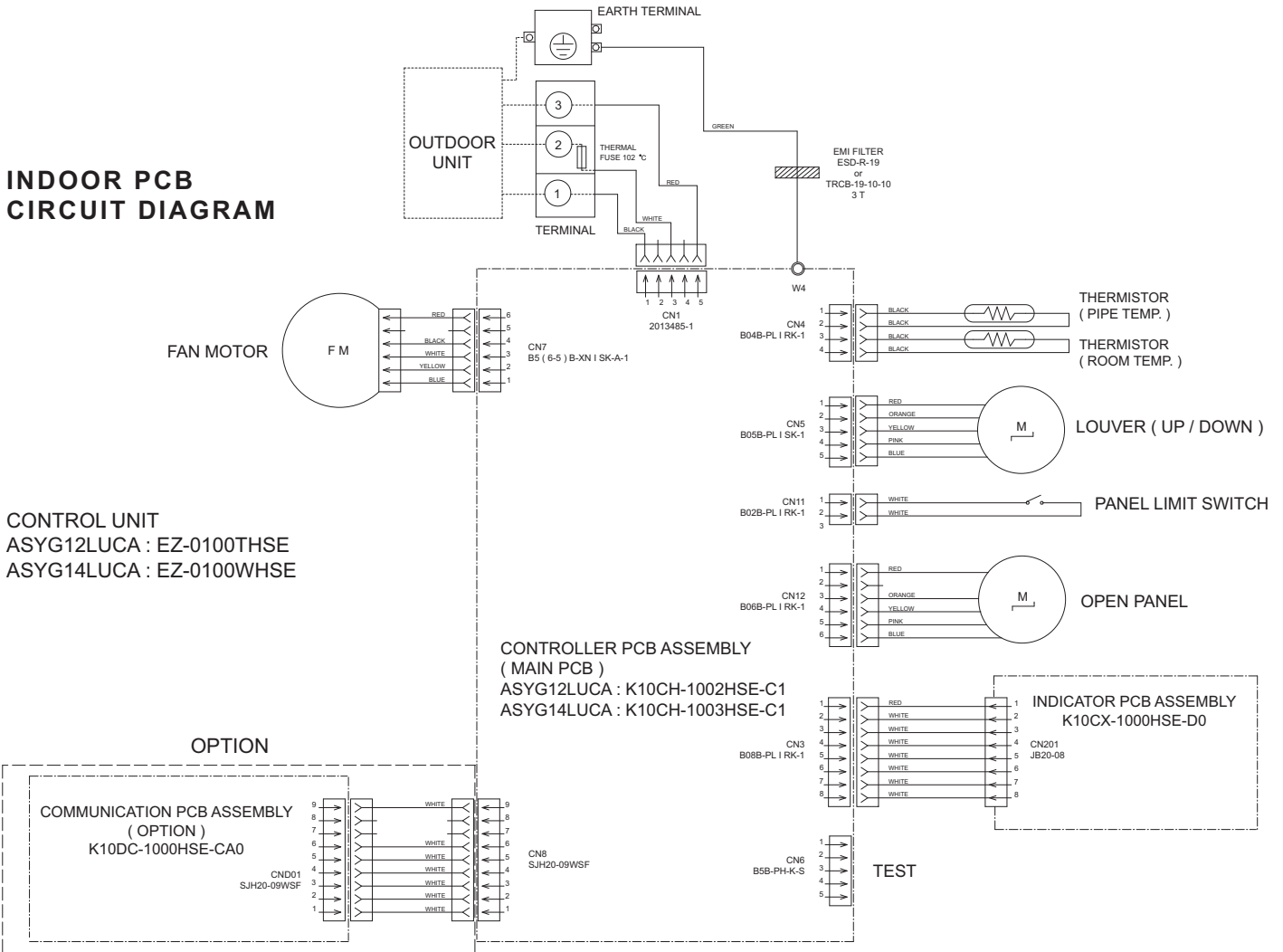

INDOOR UNIT
 INDICATOR PCB ASSEMBLY
 K10CX-1000HSE-D0

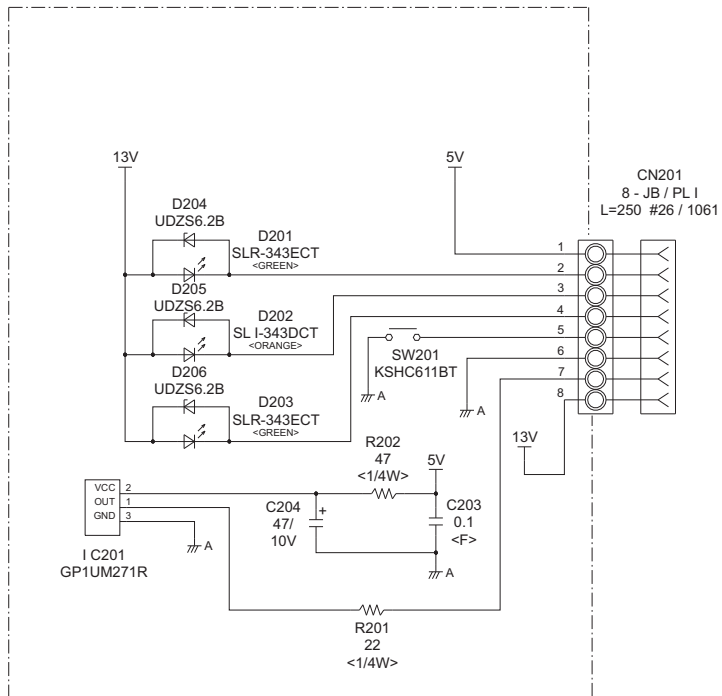

OUTDOOR PCB CIRCUIT DIAGRAM

INVERTER ASSEMBLY
 AOYG12LUC : EZ-010DHUE
 AOYG14LUC : EZ-01008HUE

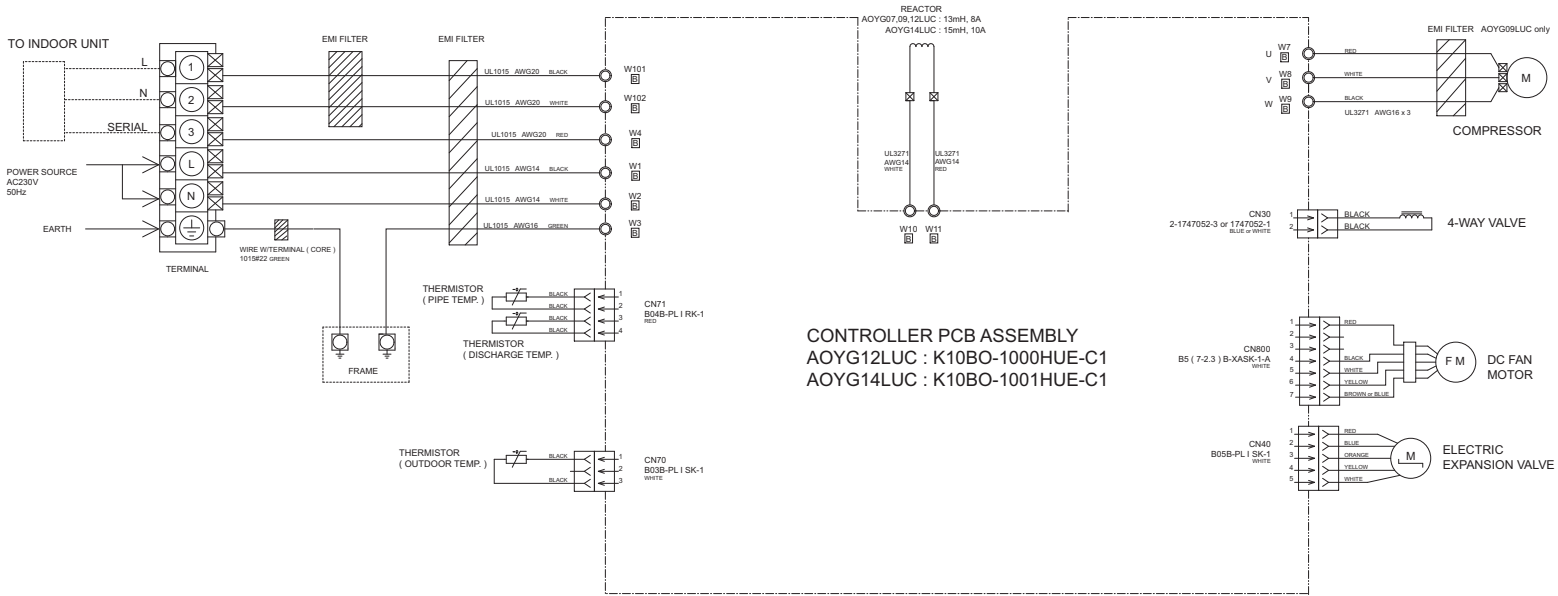

CONTROLLER PCB ASSEMBLY
 AOYG12LUC : K10BO-1000HUE-C1
 AOYG14LUC : K10BO-1001HUE-C1

OUTDOOR UNIT
 CONTROLLER PCB ASSEMBLY
 AOYG12LUC : K10BO-1000HUE-C1
 AOYG14LUC : K10BO-1001HUE-C1

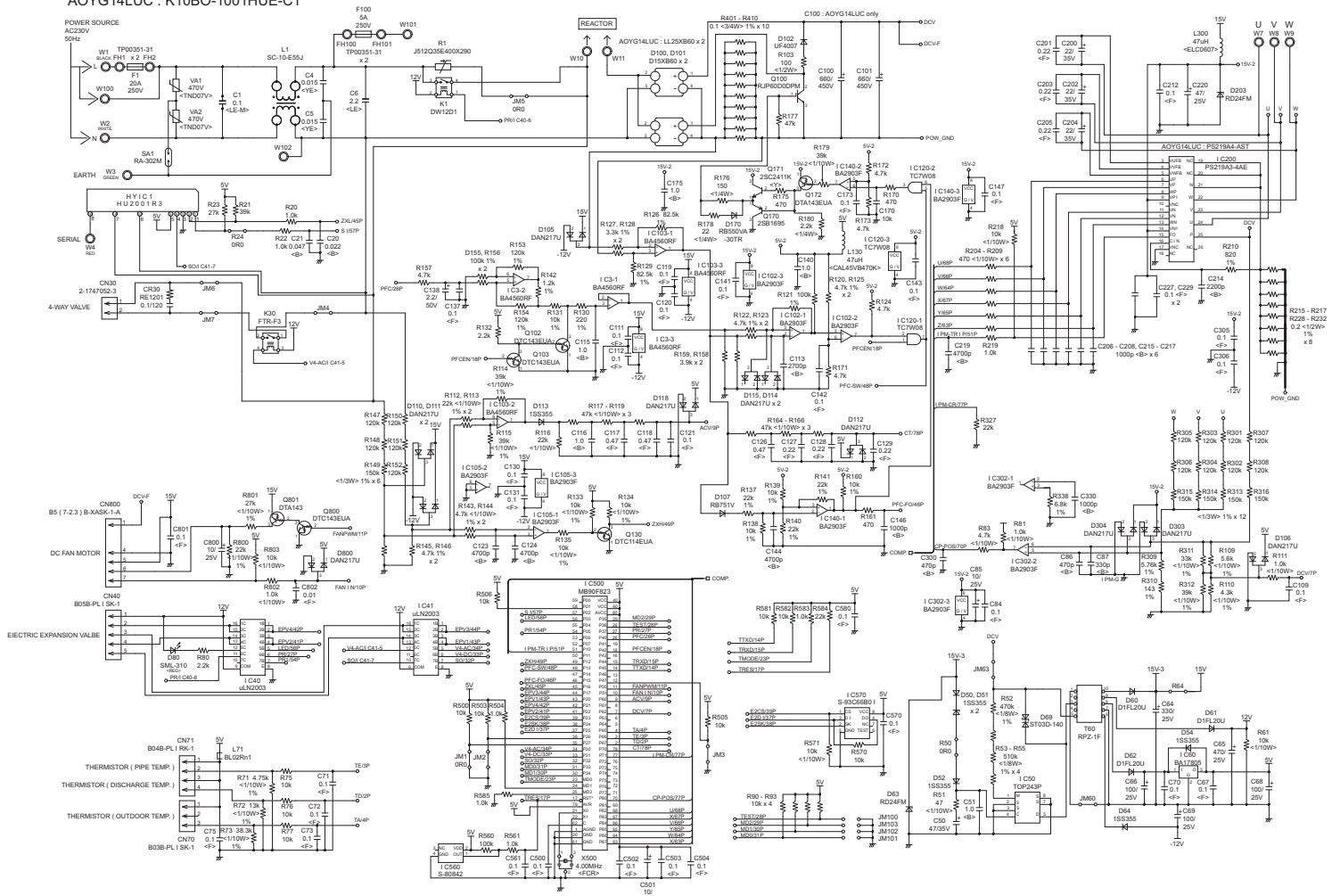

Indoor unit display

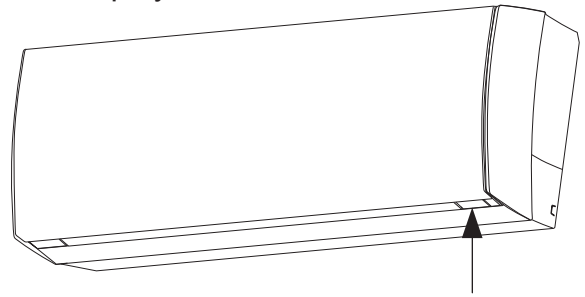

OPERATION indicator lamp (green) —
 TIMER indicator lamp (orange) —
 ECONOMY indicator lamp (green) —

ERROR DETECTION

INDOOR UNIT REMOTE CONTROL

If you use a wireless remote control, the lamp on the photo detector unit will output error codes by way of blinking patterns.

If you use a wired remote control, error codes will appear on the remote control display.

See the lamp blinking patterns and error codes in the table.

An error display is displayed only during operation.

Wired remote control display (Option)

If an error occurs, the following display will be shown. ("Er" will appear in the set room temperature display.)

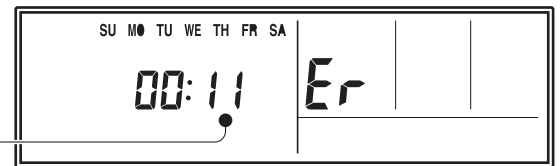

Error code

● : 0.5s ON / 0.5s OFF

◇ : 0.1s ON / 0.1s OFF

() : Number of flashing

Indoor unit			Wired remote control	Description
OPERATION lamp (green)	TIMER lamp (orange)	ECONOMY lamp (green)		
● (1)	● (1)	◇	11	Serial communication error
● (1)	● (2)	◇	12	Wired remote control communication error
● (1)	● (5)	◇	15	Check run unfinished
● (2)	● (2)	◇	22	Indoor unit capacity error
● (2)	● (3)	◇	23	Combination error
● (3)	● (2)	◇	32	Indoor unit PCB model information error
● (3)	● (5)	◇	35	Manual auto switch error
● (4)	● (1)	◇	41	Room temp. sensor error
● (4)	● (2)	◇	42	Indoor unit Heat Ex. Middle temp. sensor error
● (5)	● (1)	◇	51	Indoor unit fan motor error
● (5)	● (15)	◇	5U	Indoor unit error
● (6)	● (2)	◇	62	Outdoor unit main PCB model information error or communication error
● (6)	● (3)	◇	63	Inverter error
● (6)	● (4)	◇	64	Active filter error, PFC circuit error
● (6)	● (5)	◇	65	Trip terminal L error
● (6)	● (10)	◇	6A	Display PCB microcomputers communication error
● (7)	● (1)	◇	71	Discharge temp. sensor error

Indoor unit			Wired remote control	Description
OPERATION lamp (green)	TIMER lamp (orange)	ECONOMY lamp (green)		
● (7)	● (2)	◇	72	Compressor temp. sensor error
● (7)	● (3)	◇	73	Outdoor unit Heat Ex. liquid temp. sensor error
● (7)	● (4)	◇	74	Outdoor temp. sensor error
● (7)	● (5)	◇	75	Suction Gas temp. sensor error
● (7)	● (6)	◇	76	• 2-way valve temp. sensor error • 3-way valve temp. sensor error
● (7)	● (7)	◇	77	Heat sink temp. sensor error
● (8)	● (2)	◇	82	• Sub-cool Heat Ex. gas inlet temp. sensor error • Sub-cool Heat Ex. gas outlet temp. sensor error
● (8)	● (3)	◇	83	Liquid pipe temp. sensor error
● (8)	● (4)	◇	84	Current sensor error
● (8)	● (6)	◇	86	• Discharge pressure sensor error • Suction pressure sensor error • High pressure switch error
● (9)	● (4)	◇	94	Trip detection
● (9)	● (5)	◇	95	Compressor rotor position detection error (permanent stop)
● (9)	● (7)	◇	97	Outdoor unit fan motor error
● (9)	● (9)	◇	99	4-way valve error
● (10)	● (1)	◇	A1	Discharge temp. error
● (10)	● (3)	◇	A3	Compressor temp. error
● (10)	● (4)	◇	A4	High pressure error
● (10)	● (5)	◇	A5	Low pressure error

OUTDOOR UNIT

LED	ERROR
on	Discharge temperature abnormal
0.5 second on / 0.5 second off	IPM overcurrent protection
0.1 second on / 0.1 second off	Thermistor abnormal
2.0 second on / 2.0 second off	CT abnormal
0.1 second on / 2.0 second off	Compressor location abnormal
5.0 second on / 5.0 second off	Fan abnormal

PARTS

INDOOR UNIT

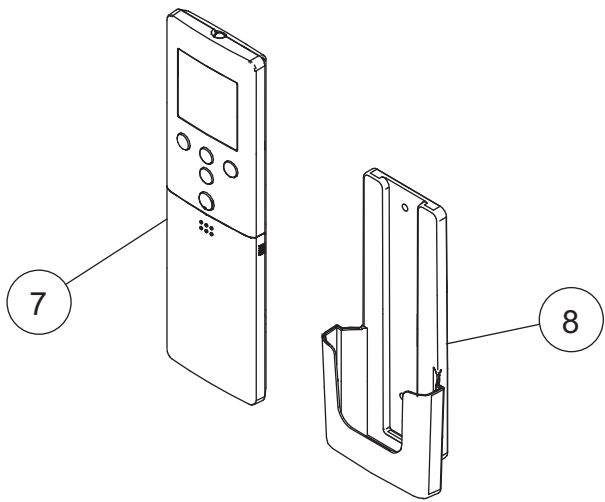
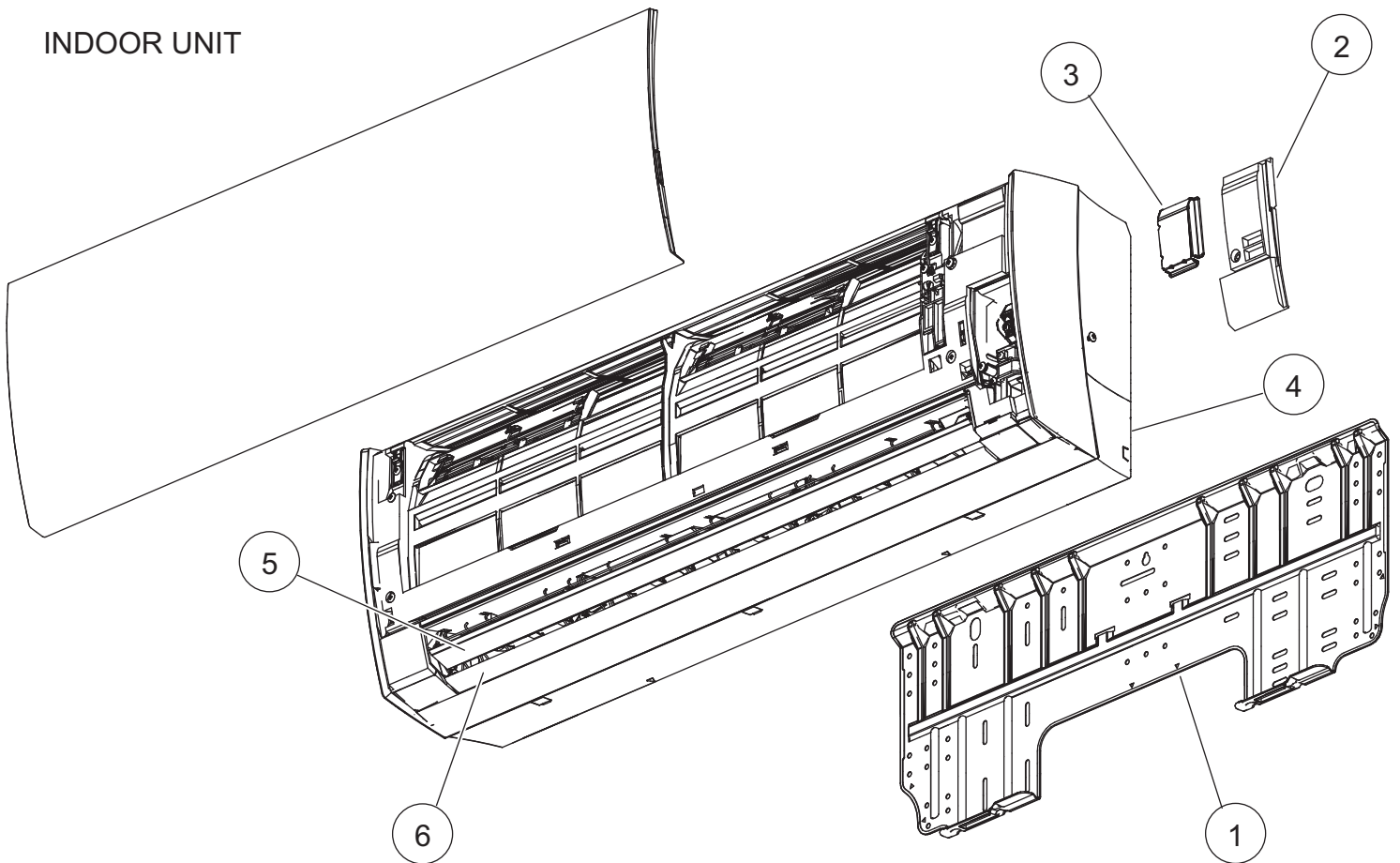

Ref.	Description	Part number
1	Bracket Panel	9318913002
2	Wire Cover	9318911008
3	Wire Shield	9318919004
4	Under Cover	9318879001
5	Louver U	9318880007
6	Louver Z	9318881004
7	Remote Control	9319207018
8	Remote Control Holder	9318912005
--	Air Clean Filter Assy	9317250009

INDOOR UNIT
Front panel

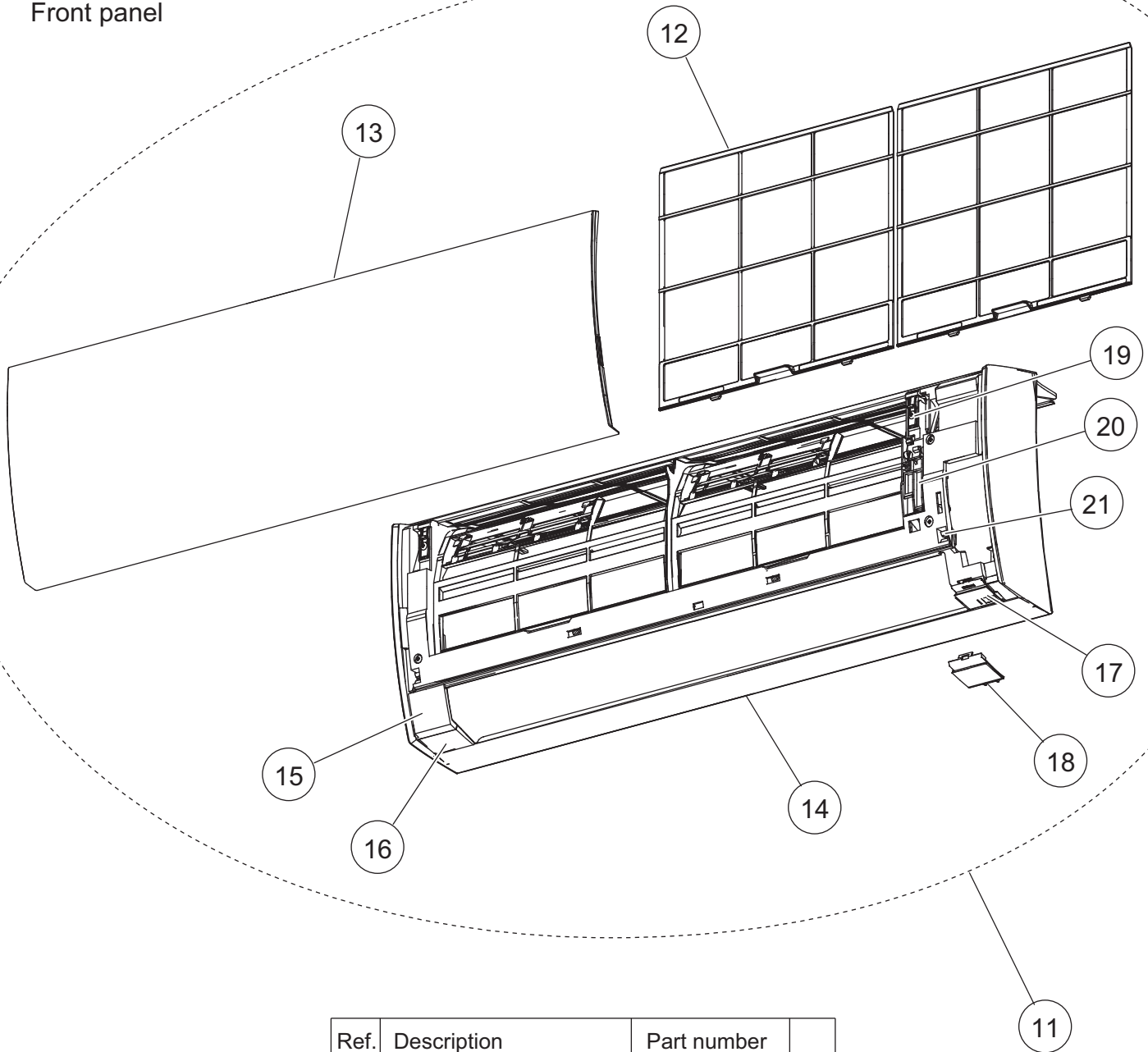

Ref.	Description	Part number	
11	Front Panel Total Assy	9319348001	
12	Air Filter	9318883008	
13	Intake Grille Assy	9319351001	
14	Front Panel	9318876000	
15	Front Panel Cover U	9318910001	
16	Display Plate Holder L	9318894004	
17	Display Plate Holder R	9318895001	
18	Display Plate R	9318893007	
19	Arm Cover	9318900002	
20	Grille Stay	9318899009	
21	Grille Clamper B	9316951006	

INDOOR UNIT
Evaporator

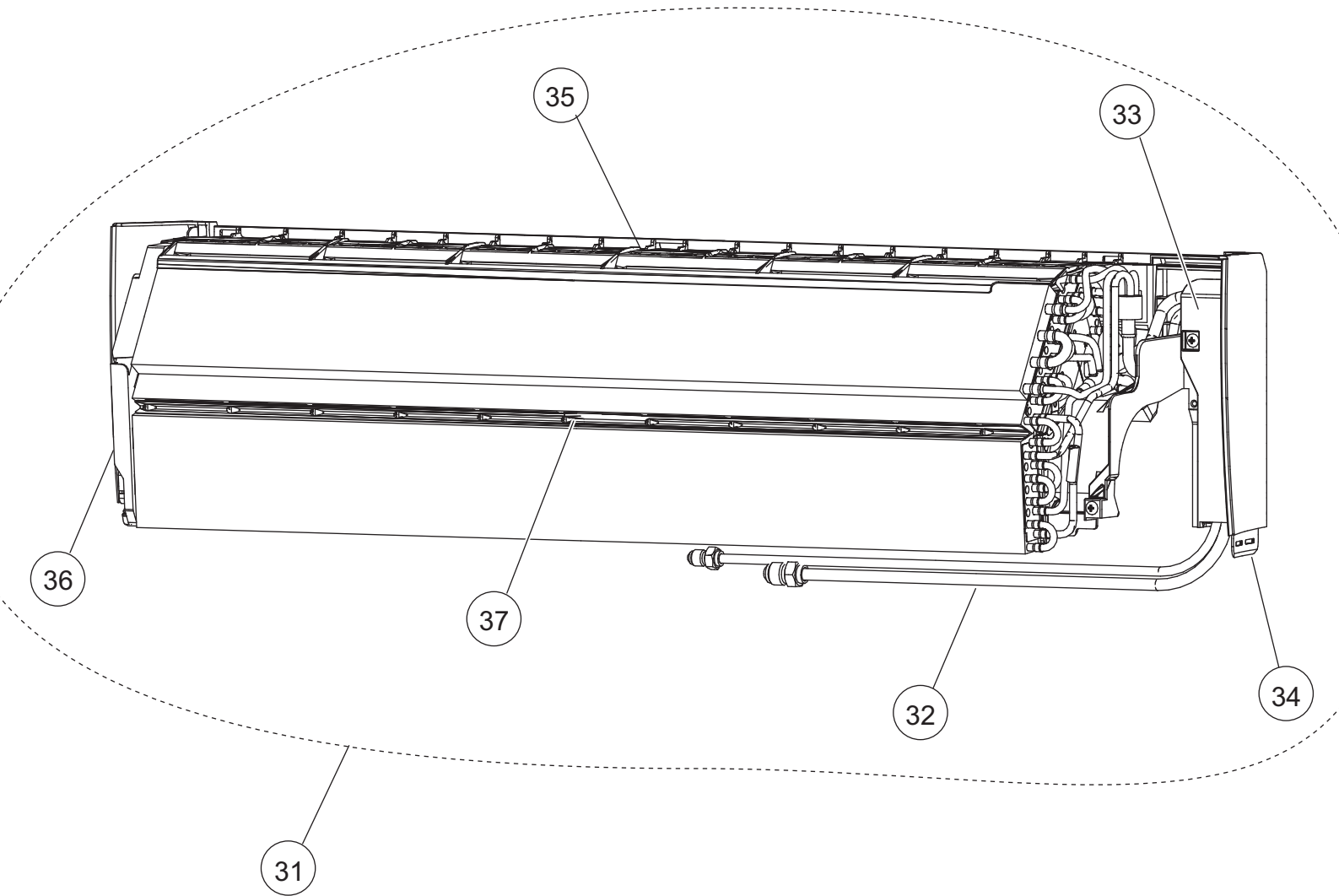

Ref.	Description	Part number	
31	Evaporator Total Assy (12)	9319327006	
31	Evaporator Total Assy (14)	9319327013	
32	Joint Pipe Assy (12)	9319322001	
32	Joint Pipe Assy (14)	9319322018	
33	Joint Pipe Holder	9318901009	
34	Base	9318874006	
35	Filter Guide	9318887006	
36	Evaporator Holder L	9318875003	
37	Air Seal	9319295008	

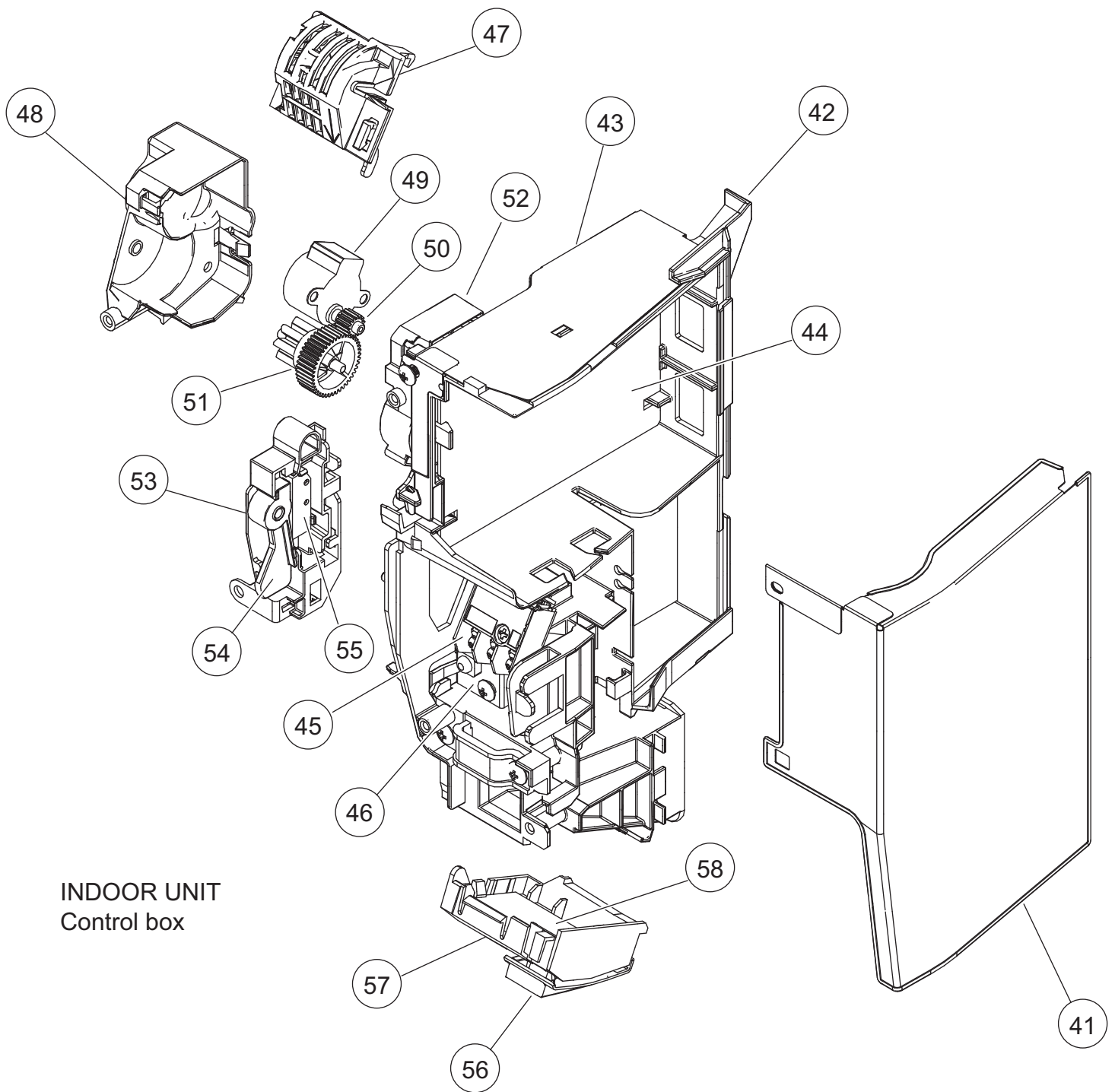

INDOOR UNIT
Control box

Ref.	Description	Part number
41	Cover Shield A	9318916003
42	Control Box	9318882001
43	Box Shield Assy	9319344003
44	Controller PCB Assy (12)	9708713038
44	Controller PCB Assy (14)	9708713045
45	Terminal	9900638009
46	Earth Terminal	9318918007
47	Room Thermistor Holder	9319068008
48	Gear Cover	9318902006
49	Step Motor	9900384166

Ref.	Description	Part number
50	Gear B	9319294001
51	Panel Gear	9319293004
52	Gear Case	9318903003
53	Switch Case	9319332000
54	Grille Key Top	9319334004
55	Micro Switch	9900625009
56	Receiver Window	9318891003
57	Display Case	9318906004
58	Display PCB Assy	9708824017
---	Thermistor Assy	9900627003

INDOOR UNIT
Casing assy

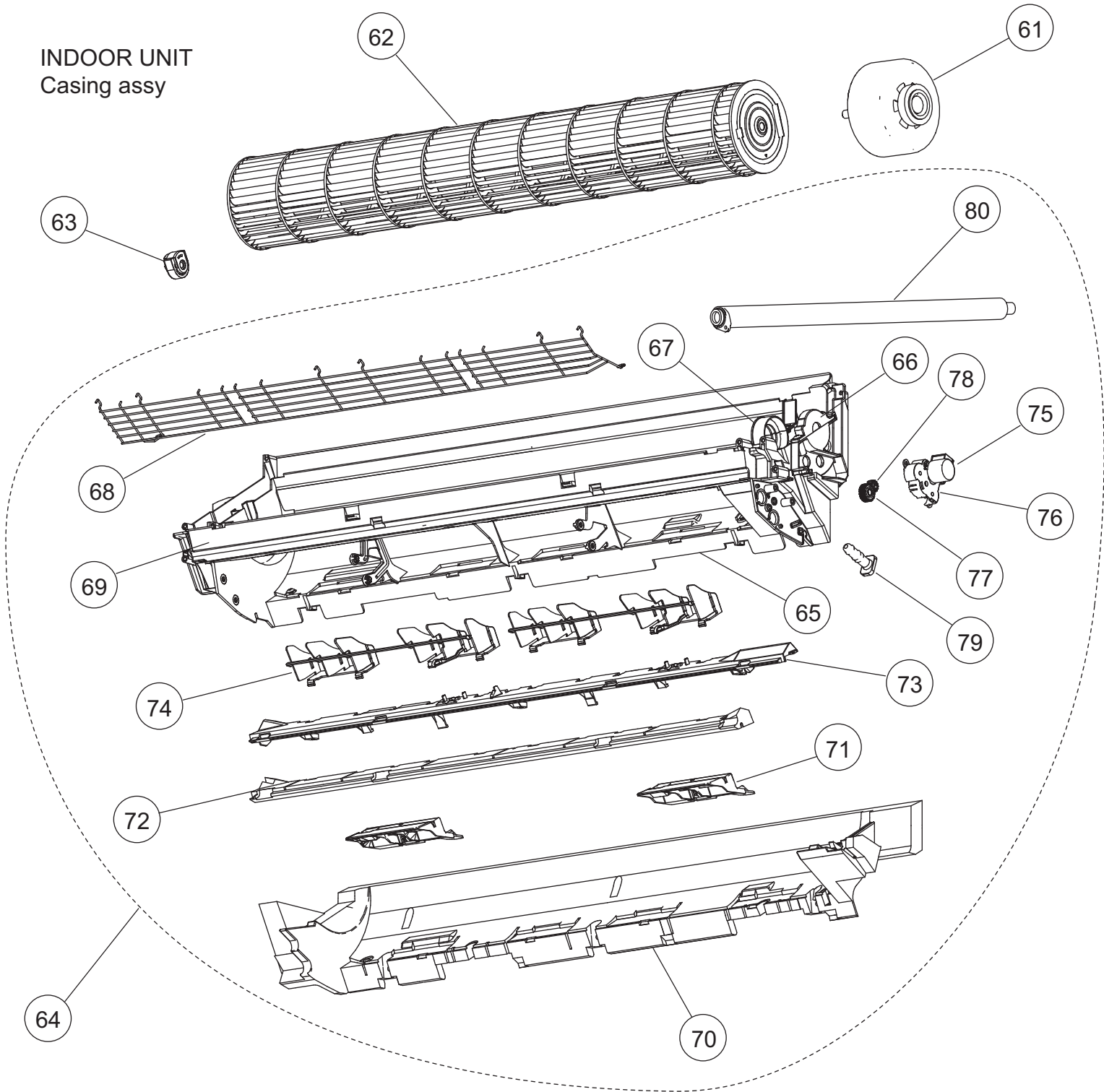

Ref.	Description	Part number
61	Fan Motor	9602947003
62	Crossflow Fan Assy	9319361000
63	Bearing C Assy	9306628017
64	Casing Assy	9319342009
65	Casing	9318873009
66	Motor Cover	9316601000
67	Motor Cover	9318888003
68	Fan Guard	9318924008
69	Casing Cover F	9318923001
70	Casing Cover B	9318920000

Ref.	Description	Part number
71	Pipe Bracket	9318889000
72	Panel Cover	9319296005
73	Louver Holder	9318886009
74	R and L Louver B	9318885002
75	Motor Step	9900384128
76	Louver Gear Holder	9318905007
77	Louver Gear	9318904000
78	Gear A	9309994003
79	Drain Cap	9316177017
80	Drain Hose Assy	9316904002

PARTS

OUTDOOR UNIT

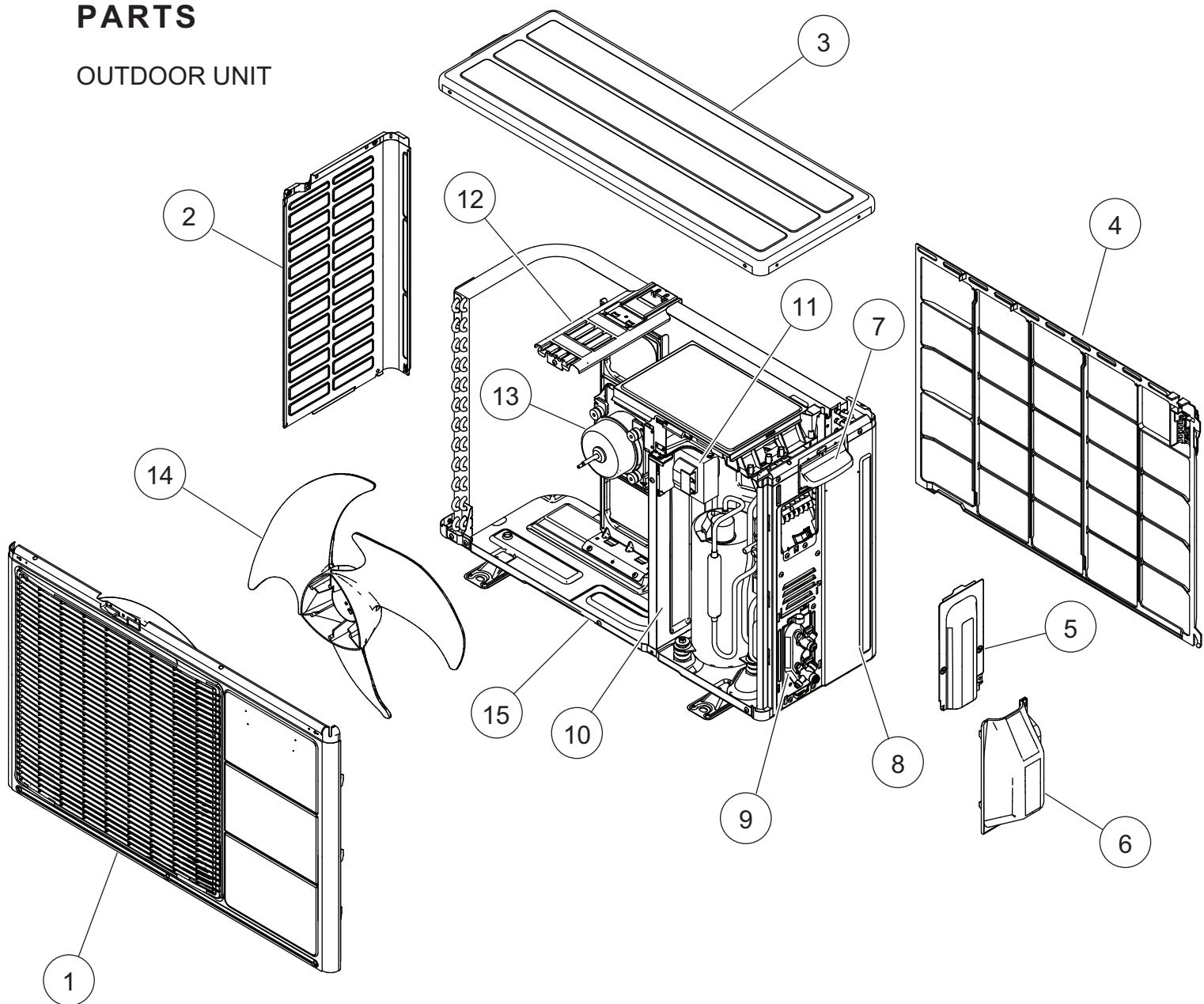

Ref.	Description	Part number
1	Front Panel Assy	9317760010
2	Cabinet Left Assy	9318247008
3	Top Panel Assy	9317761055
4	Protective Net	9313941055
5	Switch Cover A Assy	9317795005
6	Switch Cover B	9317582001
7	Grip	9317588003
8	Cabinet Right Assy	9317759021
9	Valve Bracket	9331649001

Ref.	Description	Part number
10	Separator Assy	9318340013
11	Reactor Assy (12)	9900583002
11	Reactor Assy (14)	9900611019
12	Motor Bracket Assy	9332289039
13	Fan Motor	9602864003
14	Propeller Fan	9313808013
15	Base Assy	9316885028
--	Drain Assy	9303029022
--	Emblem	9319151007

OUTDOOR UNIT

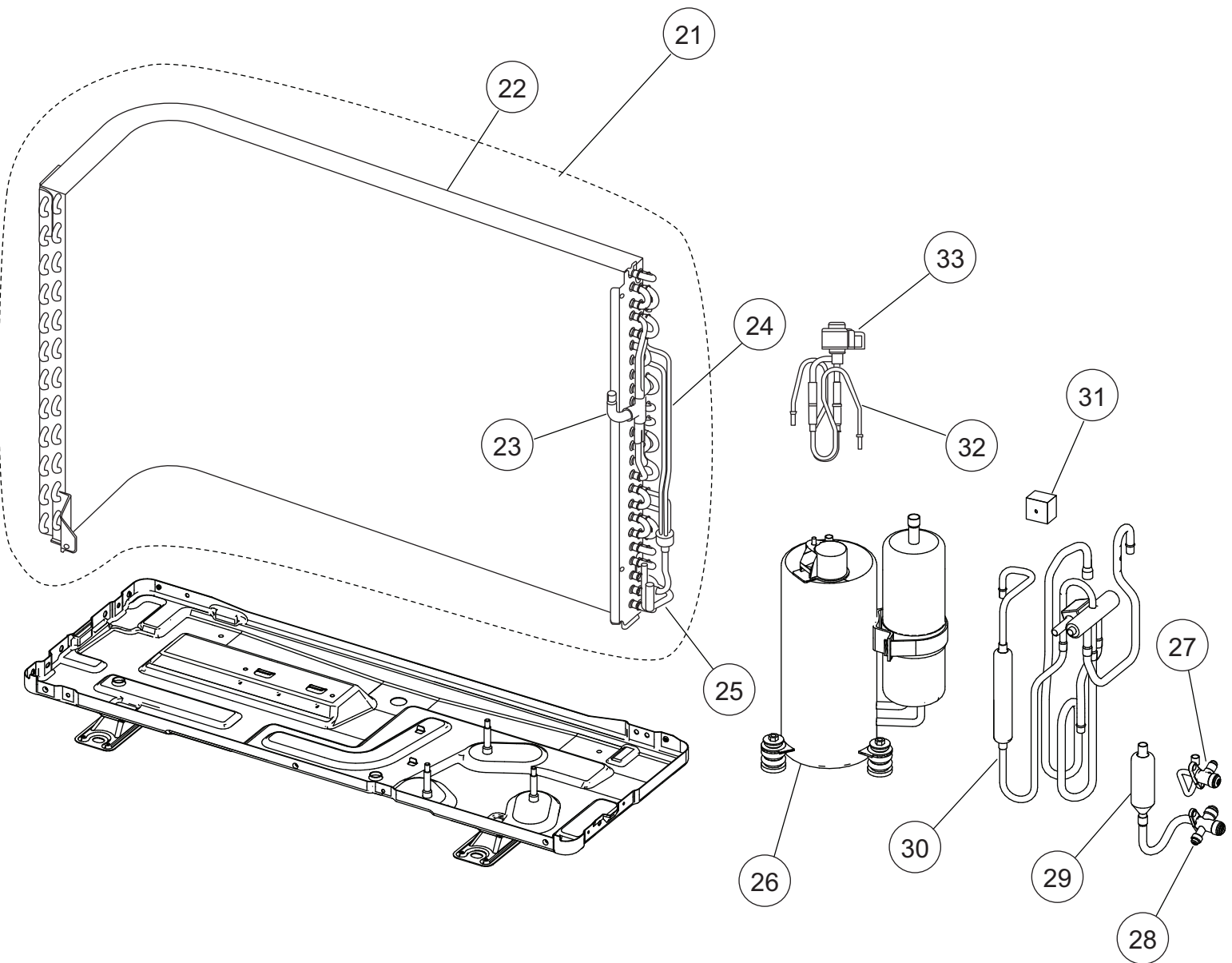

Ref.	Description	Part number
21	Condenser Total Assy	9332359008
22	Condenser Assy	9332360004
23	Inlet Pipe Assy	9315578013
24	Separate Pipe Assy	9317200011
25	Exit Pipe Assy	9332361001
26	Compressor Assy	9317619004
27	2 way Valve Assy	9332371000

Ref.	Description	Part number
28	3 way Valve Assy (12)	9315574015
28	3 way Valve Assy (14)	9332455007
29	Muffler (12)	9308625007
29	Muffler (14)	9316276017
30	4 way Valve Assy	9332365009
31	Solenoid	9970110023
32	Pulse Motor Valve Assy	9332368000
33	Expansion Valve Coil	9970095030

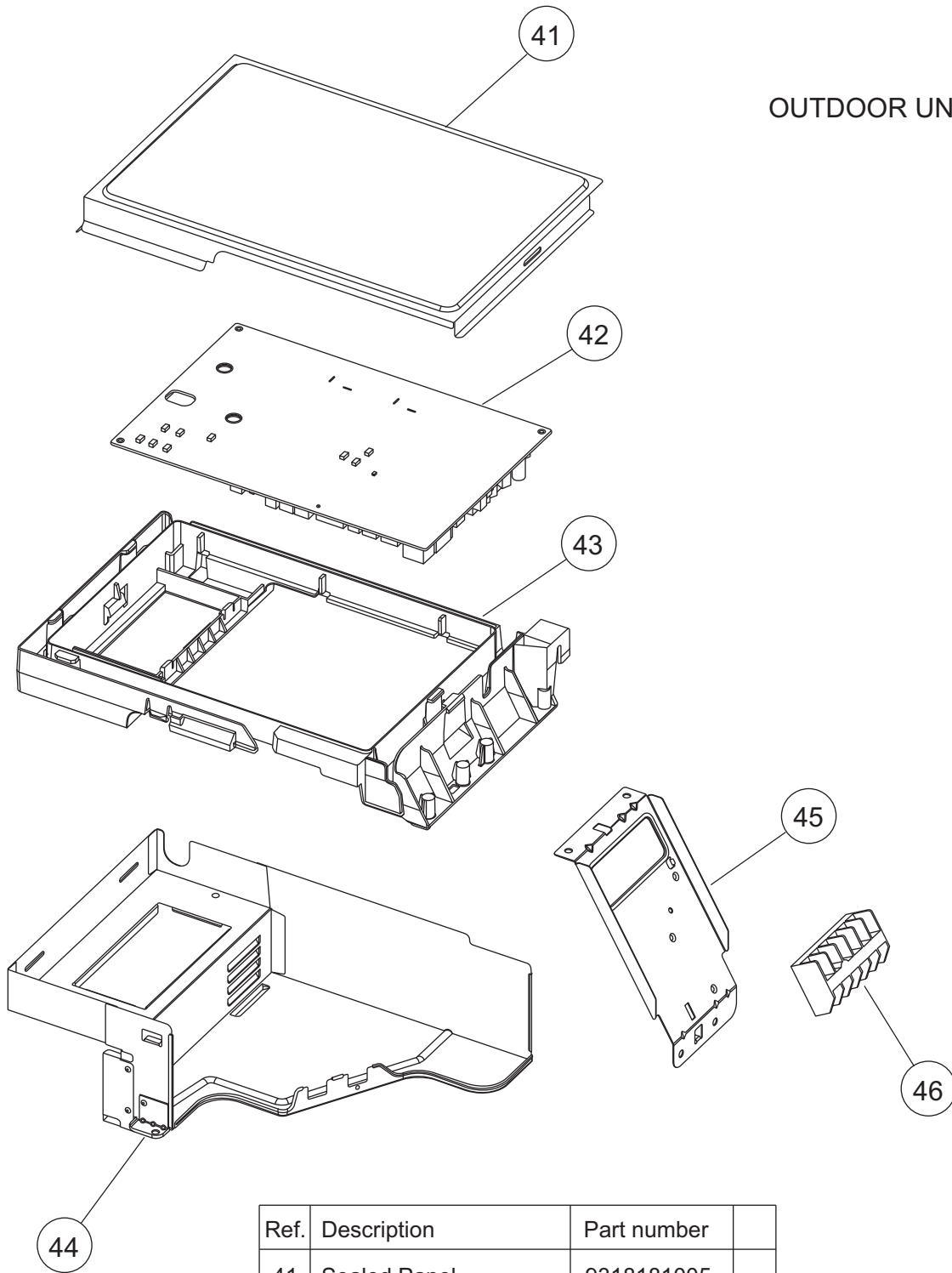

OUTDOOR UNIT



Ref.	Description	Part number	
41	Sealed Panel	9318181005	
42	Controller PCB Assy (12)	9708683010	
42	Controller PCB Assy (14)	9708683027	
43	PCB Holder	9318182002	
44	Inverter Case Assy	9318242003	
45	Terminal Bracket	9317603010	
46	Terminal	9900435028	
--	Outdoor Thermistor	9900565008	
--	Thermistor Assy	9900628000	

ACCESSORIES

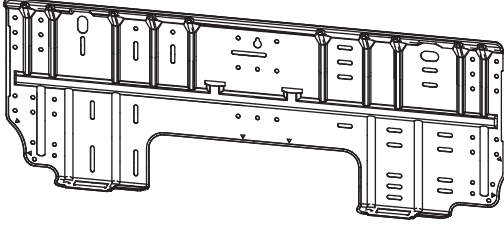
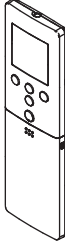
INDOOR UNIT

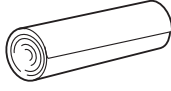
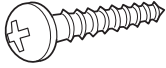
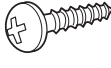
Name and Shape	Part number
Bracket panel 	9318913002
Remote control 	9319207018
Remote control holder 	9318912005
Battery (penlight) 	0600185046
Cloth tape 	9308117007
Tapping screw (big) (ϕ 4 x 25) 	0700076046
Tapping screw (small) (ϕ 3 x 12) 	0700019036

OPTION

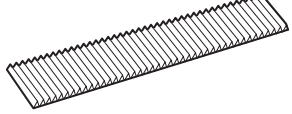
Name and Shape	Part number
Air cleaning filter 	UTR-FA16 UTR-FA16-2

1103G3922