



# Applied Systems Technical Data

Water cooled chiller with centrifugal compressor



EEEDEN13-438

EWWD-FZXS



# TABLE OF CONTENTS

## EWWD-FZXS

1	Features .....	2
2	Specifications .....	3
	Technical Specifications .....	3
	Electrical Specifications .....	3
3	Nomenclature .....	5
	Nomenclature .....	5
4	Dimensional drawings .....	6
	Dimensional Drawings .....	6
5	Sound data .....	8
	Sound Pressure Spectrum .....	8
6	Installation .....	9
	Installation Method .....	9
7	Operation range .....	10
	Operation Range .....	10
8	Specification text .....	11
	Specification Text .....	11

# 1 Features

- An inverter driven compressor allows the capacity to be adjusted precisely to match variations in room and outside temperatures
- Onboard digital electronics provide smart controls

1



## 2 Specifications

2-1 Technical Specifications				EWWD320FZXS	EWWD430FZXS	EWWD520FZXS	EWWD640FZXS	EWWD860FZXS	EWWD10FZXS	
Cooling capacity	Min.		kW	114	128	172	114	128	172	
	Nom.		kW	314	399	517	559	729	888	
	Max.		kW	317	429	521	635	856	1,048	
Capacity control	Method Variable speed centrifugal compressor									
Power input	Cooling	Min.		kW	21.6	27.7	33.1	21.6	27.7	33.1
		Nom.		kW	65.1	74.8	105	107	130	159
		Max.		kW	65.9	85.7	104	132	171	206
EER				4.83	5.34	4.93	5.21 (1)	5.61	5.58	
ESEER				7.74	8.10	8.37	8.10	8.46	8.64	
Casing	Colour			Ivory white						
	Material			Galvanized and painted steel sheet						
Dimensions	Unit	Height		mm	1,823		1,755	1,748	1,794	
		Width		mm	1,276		1,790	1,853	1,904	
		Depth		mm	3,254	3,419	3,441	3,289	3,401	
Weight	Unit			kg	2,360	2,546	3,709	4,095	4,765	
	Operation weight			kg	2,520	2,812	4,074	4,548	5,330	
Water heat exchanger - evaporator	Type			Flooded shell and tube (2 passes)						
	Water flow rate		Nom.	l/s	15.1	24.9	30.3	40.9	50.1	
	Nominal water pressure drop		Cooling	Heat exchanger	kPa	30	23	18	21	11
	Insulation material			Closed cell						
Water heat exchanger - condenser	Type			Flooded shell and tube (2 passes)						
	Water flow rate		Nom.	l/s	18.3	29.9	36.7	49.1	59.9	
	Nominal water pressure drop		Cooling	kPa	24	28	24	25	29	
	Insulation material			Closed cell						
Sound power level	Cooling	Nom.	dBA	89.0	90.1	91.2	92.4	93.6	94.6	
Sound pressure level	Cooling	Nom.	dBA	70.9 (6)	72.0 (6)	73.0 (6)	73.8 (6)	75.1 (6)	75.9 (6)	
Compressor	Type			Oil free centrifugal compressor with magnetic bearings						
	Quantity			1		2				
Operation range	Evaporator	Cooling	Min.	°CDB	2					
			Max.	°CDB	15					
	Condenser	Cooling	Min.	°CDB	18					
			Max.	°CDB	46					
Refrigerant	Type			R-134a						
	Charge			kg	210	180	220	300		
	Circuits			Quantity	1					
Piping connections	Evaporator water inlet/outlet (OD)			168.3mm	219.1mm			273mm		
	Condenser water inlet/outlet (OD)			168.3mm			219.1mm			
Safety devices	Item	01 Low suction pressure								
		02 High discharge pressure								
		03 Surge high motor temperature								
		04 Low motor current								
		05 Starter fault								
		06 Sensor fault								
		07 Evaporator-condenser water flow loss								

2-2 Electrical Specifications				EWWD320FZXS	EWWD430FZXS	EWWD520FZXS	EWWD640FZXS	EWWD860FZXS	EWWD10FZXS	
Compressor	Phase			3~						
	Voltage			V 400						
	Voltage range	Min.		%						
		Max.		%						
	Maximum running current			A	135	210	176	135	210	176
Starting method			VFD driven							
Compressor 2	Maximum running current			A	-			135	210	176

## 2 Specifications

2

2-2 Electrical Specifications				EWWD320 FZXS	EWWD430 FZXS	EWWD520 FZXS	EWWD640 FZXS	EWWD860 FZXS	EWWD10 FZXS
Power supply	Phase			3~					
	Frequency		Hz	50					
	Voltage		V	400					
	Voltage range	Min.	%	-10					
		Max.	%	10					
Unit	Maximum starting current		A	135	213	176	270	420	352
	Nominal running current (RLA)	Cooling	A	104 (9)	142 (9)	168 (9)	207 (9)	285 (9)	335 (9)
			A	135	210	176	270	420	352
	Max unit current for wires sizing		A	149.0	231	194	297	462	385

### Notes

- (1) Oil free centrifugal chillers provide different cooling capacity, power input, EER, etc. (at fixed evaporator and condenser water conditions) depending on the compressor speed of rotation
- (2) Figures are based on standard conditions: evaporator 12/7°C; condenser 30/35°C; EER & ESEER reported are the maximum at these conditions and at a specific speed.
- (3) A dedicated selection tool (EWWD-FZ selection software) is available to select the units and calculate the performance at specific working conditions
- (4) For dual compressor units the minimum capacity is related to the condition with only one compressor running
- (5) Nominal water flow rate and pressure drop values are related to maximum cooling capacity at standard conditions; values at specific working conditions can be calculated by the selection software
- (6) Sound pressure related to maximum cooling capacity at standard conditions, according to ISO 3744 at 1m and free field semi spherical conditions
- (7) Allowed voltage tolerance  $\pm 10\%$ . Voltage unbalance between phases must be within  $\pm 3\%$ .
- (8) Maximum starting current: starting current of biggest compressor + current of the other compressor at 75 % of maximum load + fans current
- (9) Cooling: entering evaporator water temp. 12°C; leaving evaporator water temp. 7°C; entering condenser water temp. 30°C; leaving condenser water temp. 35°C
- (10) Maximum running current is based on max compressor absorbed current in its envelope
- (11) Maximum unit current for wires sizing is based on minimum allowed voltage.
- (12) Maximum current for wires sizing: compressor full load ampere x 1.1
- (13) See separate drawing for operation range

### 3 Nomenclature

#### 3 - 1 Nomenclature

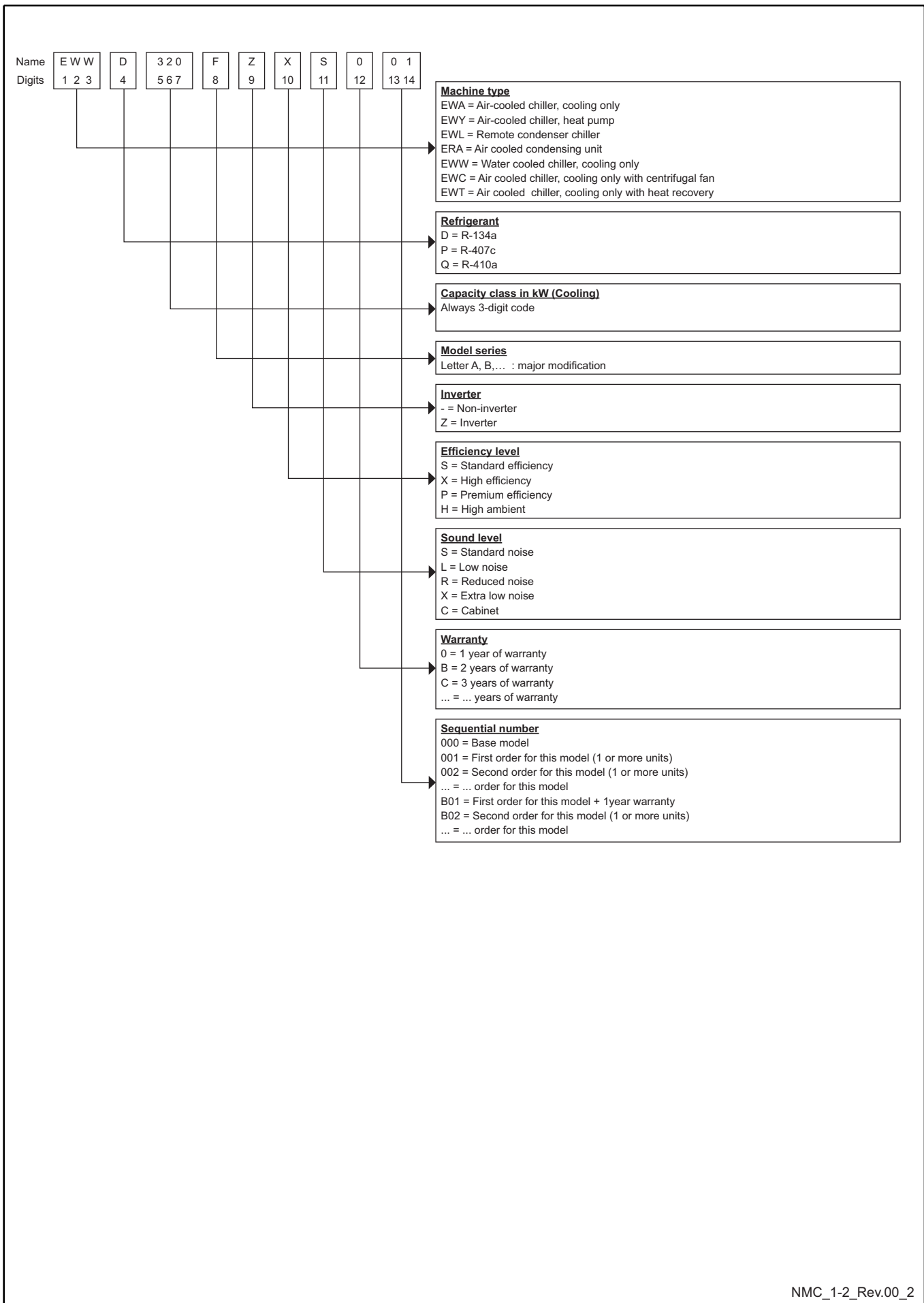

## 4 Dimensional drawings

### 4 - 1 Dimensional Drawings

EWWD320-520FZ

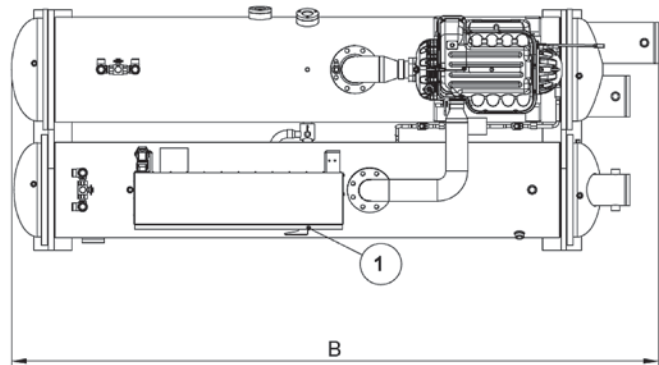
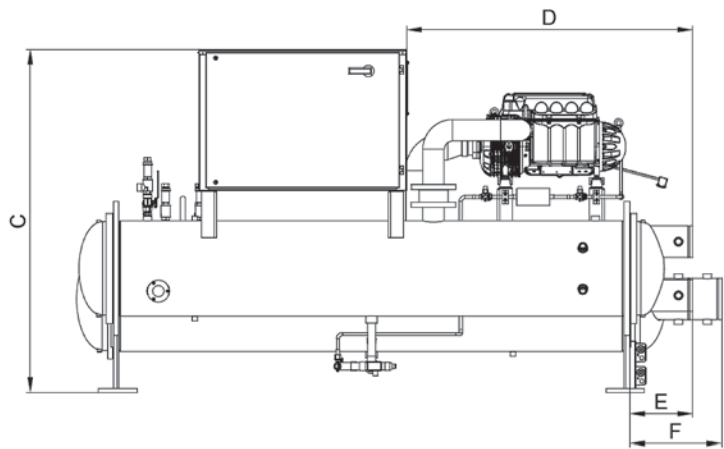
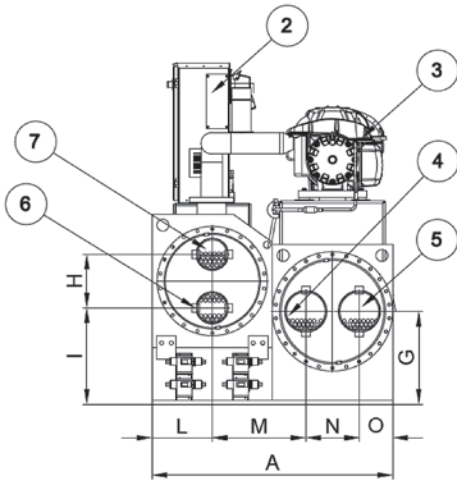

EWWD-FZ	Dimensions													
	A	B	C	D	E <sup>(1)</sup>	F <sup>(2)</sup>	G	H	I	L	M	N	O	
320	1276	3254	1822	1518	334	334	496	286	515	319	495	286	176	
430	1276	3254	1822	1518	334	334	496	286	515	319	495	286	176	
520	1276	3419	1822	1518	334	487	496	286	515	319	496	284	177	

<sup>(1)</sup> Condenser hydraulic connections

<sup>(2)</sup> Evaporator hydraulic connections

Note: the above drawing refers to size 520.

#### LEGEND

- 1 - Electrical Panel
- 2 - Power Connection Slot
- 3 - Compressor
- 4 - Evaporator Water Inlet
- 5 - Evaporator Water Outlet
- 6 - Condenser Water Inlet
- 7 - Condenser Water Outlet

DMN\_1-2\_Rev.00\_1



## 4 Dimensional drawings

### 4 - 1 Dimensional Drawings

EWWD640-C10FZ

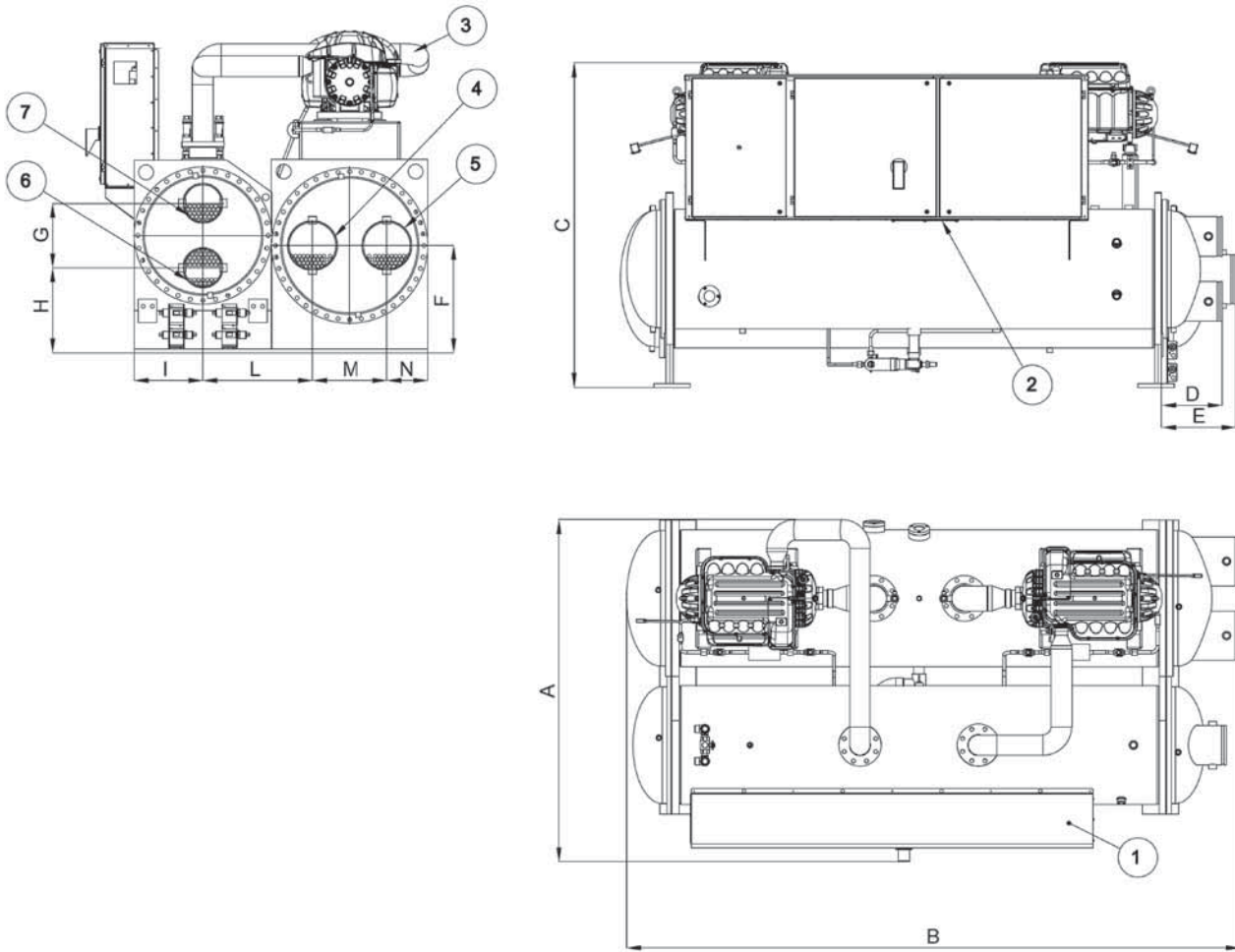

EWWD-FZ	Dimensions											
	A	B	C	D <sup>(1)</sup>	E <sup>(2)</sup>	F	G	H	I	L	M	N
640	1790	3441	1755	487	334	546	284	542	319	522	360	203
860	1853	3289	1748	334	334	546	360	496	383	585	360	203
C10	1904	3401	1794	334	411	598	360	474	383	609	413	227

<sup>(1)</sup> Condenser hydraulic connections

<sup>(2)</sup> Evaporator hydraulic connections

Note: the above drawing refers to size C10.

#### LEGEND

- 1 - Electrical Panel
- 2 - Power Connection Slot
- 3 - Compressor
- 4 - Evaporator Water Inlet
- 5 - Evaporator Water Outlet
- 6 - Condenser Water Inlet
- 7 - Condenser Water Outlet

DMN\_1-2\_Rev.00\_1

## 5 Sound data

### 5 - 1 Sound Pressure Spectrum

5

EWWD-FZXS

Unit size	Sound pressure level at 1 m from the unit in semispheric free field (rif. $2 \times 10^{-5}$ Pa)									Power
	63 Hz	125 Hz	250 Hz	500 Hz	1000 Hz	2000 Hz	4000 Hz	8000 Hz	dB(A)	dB(A)
320	38,7	50,1	55,6	58,8	64,5	62,7	63,6	66,6	70,9	89,0
430	39,2	50,6	57,0	59,8	66,0	63,5	64,7	67,9	72,0	90,1
520	39,7	51,7	57,7	61,1	66,8	64,6	66,1	68,5	73,0	91,2
640	41,7	53,0	58,6	61,8	67,4	65,8	66,4	69,6	73,8	92,4
860	42,2	53,6	60,0	62,9	69,1	66,4	67,9	71,0	75,1	93,6
C10	42,7	54,9	60,7	63,9	69,8	67,5	69,1	71,3	75,9	94,6

#### NOTES

Figures in the table are related to standard working conditions (evaporator water 12/7°C and condenser water 30/35°C) and maximum cooling capacity

NSL\_1-2\_Rev.00\_1

#### Sound pressure level reduction values for different distances

EWWD-FZXS

Unit size	Distance						
	1m	5m	10m	15m	20m	25m	50m
320	0,0	-8,7	-13,7	-16,9	-19,2	-21,1	-26,9
430	0,0	-8,7	-13,8	-17,0	-19,3	-21,1	-26,9
520	0,0	-8,7	-13,7	-16,9	-19,2	-21,0	-26,8
640	0,0	-8,4	-13,4	-16,6	-18,9	-20,7	-26,5
860	0,0	-8,5	-13,5	-16,6	-18,9	-20,7	-26,5
C10	0,0	-8,4	-13,4	-16,5	-18,8	-20,6	-26,4

#### NOTES

Reduction to be applied to standard sound levels

NSL\_1-2\_Rev.00\_2

## 6 Installation

### 6 - 1 Installation Method

#### Warning

Installation and maintenance of the unit must be performed only by qualified personnel who have knowledge with local codes and regulations, and experience with this type of equipment. Must be avoided the unit installation in places that could be considered dangerous for all the maintenance operations.

#### Handling

Care should be taken to avoid bumping and/or jolting during unloading from the lorry and moving the unit. Do not push or pull the machine from any part other than the base frame. Secure the machine inside the lorry to prevent it from moving and causing damage to the panels and to the base frame. Do not allow any part of the unit to fall during transportation or unloading, as this could cause serious damage.

All units of the series are supplied with lifting points marked in yellow. Only these points may be used for lifting the unit, as shown in the following figure (the picture is indicative, so lifting tools are not supplied)

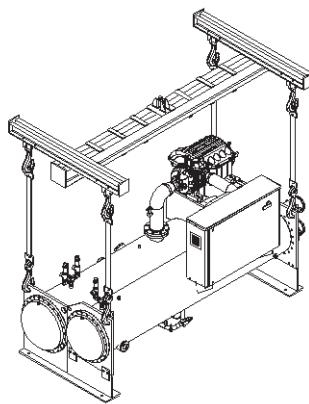

#### Location

All units are designed for indoor installations. The machine must be installed on a robust and perfectly level foundation; should the machine be installed on balconies or roofs, it might be necessary to use weight distribution beams.

For installation on the ground, a strong cement base that is at least 250 mm wider and longer than the machine must be prepared. Also, this base must be strong enough to support the weight of the machine as stated in the technical specifications. If the machine is installed in places that are easily accessible to people and animals, it is advisable to install protection gratings for the compressor section.

To ensure the best possible performance on the installation site, the following precautions and instructions must be followed:

- Make sure to provide a strong and solid foundation to reduce noise and vibration as much as possible.
- The water in the system must be particularly clean and all traces of oil or rust must be removed. A mechanical water filter must be installed on the machine's inlet piping.

#### Space requirements

Every side of the machine must be accessible for all post-installation maintenance activities.

In particular, service clearance has to be provided at one end of the unit for possible removal of evaporator and/or condenser tubes. Evaporator and condenser tubes are rolled into the tube sheets to permit replacement if necessary; the length of the vessel must be allowed at one end (doors or removable wall sections can be utilized).

Keep a free space to allow the opening of electrical panel doors.

Minimum clearance at all sides, including the top, is 1 meter; local regulation may require larger clearance.

The above recommended information are representative of general installation. A specific evaluation should be done by contractor depending on the case.

# 7 Operation range

## 7 - 1 Operation Range

7

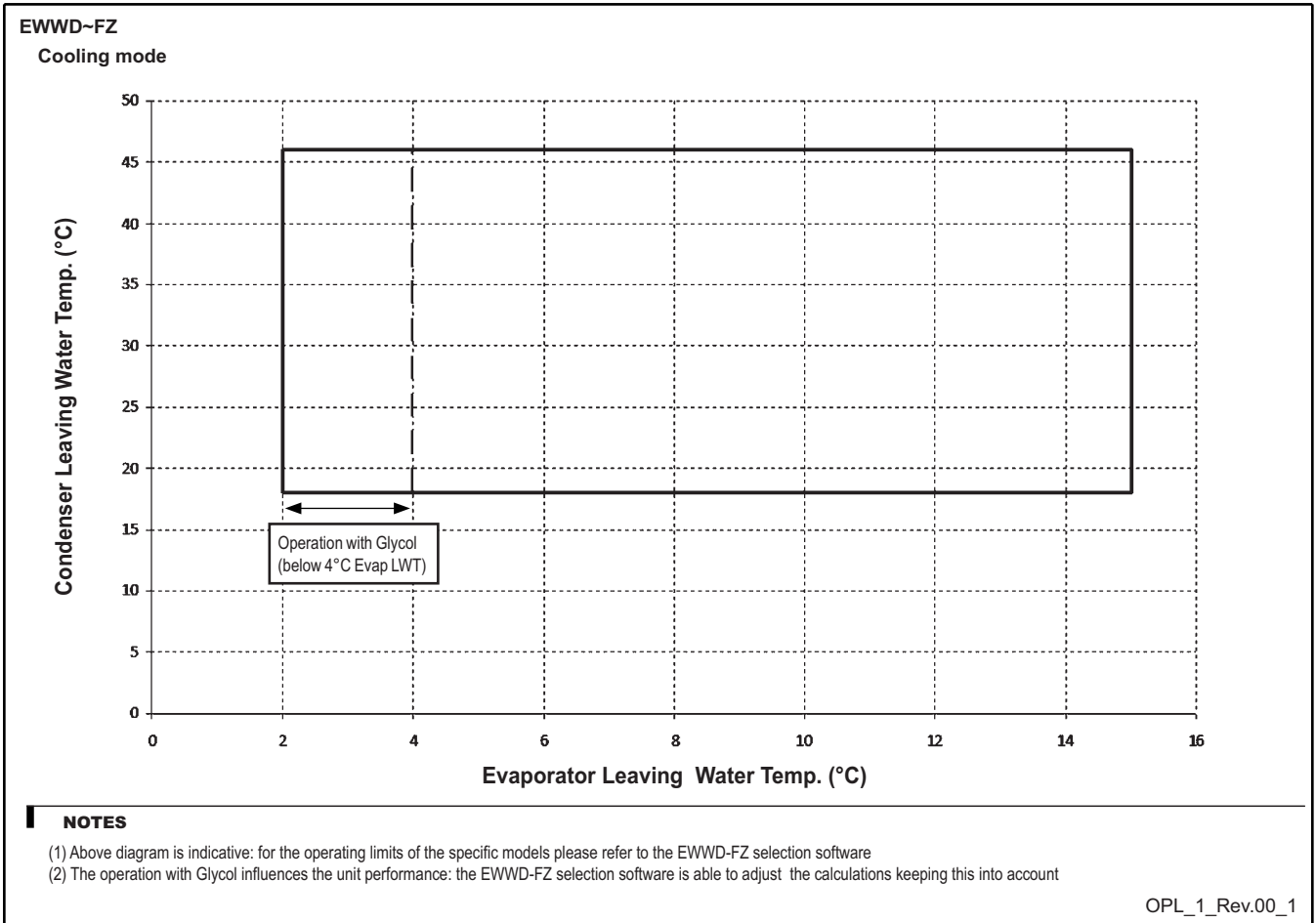

## 8 Specification text

### 8 - 1 Specification Text

#### Next Generation Centrifugal

The industry's next generation of centrifugal chillers is here today with EWWD-FZ chillers. The new technology begins with centrifugal compressors utilizing frictionless magnetic bearings for oil-free operation, integral variable-frequency drives, and high-speed direct drive technology. The high efficiency compressor is matched with highly efficient heat exchangers to make an impressive chiller. The control system is based on MicroTech II® family to provide the optimum chiller control system.

#### Benefit Summary

- **Breakthrough energy efficiency**, especially at part load conditions, resulting in great energy savings.
- **Increased reliability** This frictionless magnetic bearing design needs no oil management system, resulting in increased reliability and reduced maintenance. With no oil to coat the heat transfer surfaces, a gain in heat exchanger efficiency can also be realized.
- **Compact design and light weight** The compressor weight of 120 kg is less than 20% of the weight of competitive compressors and approximately 50% smaller, this allows a compact unit design thus making this series the perfect choice for retrofit projects
- **Low noise level** The EWWD-FZ chiller is one of the quietest in its size range: this eliminates the need for expensive sound attenuation accessories and makes the unit ideal for every sound sensitive environments such as schools, performance halls, museums, etc.
- **Extremely low vibration levels** As a result of the high-speed design, the compressor vibration levels are extremely low, minimizing vibration that could be transmitted to the structure.
- **Smart refrigerant choice** The compressor is optimized for R-134a, the positive pressure refrigerant with no phase-out schedule and no ozone depletion.
- **Smart controls** Onboard digital electronics provide smart controls. The compressor is totally self-correction and incorporates a system of sophisticated self-diagnostics, monitoring and controls. In the event of a power failure, the compressor motor acts as a generator, providing power for the bearing control system during coast down. It also has a system to gently de-levitate the shaft.
- **Easy integration with BMS** The unit controller can be connected to BMS (Building Management System) based on the most common protocols as LONWORKS®, BACnet®, or Modbus®
- **Extensive option list** A wide portfolio of options is available to meet different requirements

#### Code requirements – Safety and observant of laws/directives

All EWWD-FZ units are designed and manufactured in accordance with applicable selections of the following:

Construction of pressure vessel	97/23/EC (PED)
Machinery Directive	2006/42/EC
Low Voltage	2006/95/EC
Electromagnetic Compatibility	2004/108/EC
Electrical & Safety codes	EN 60204-1 / EN 60335-2-40
Manufacturing Quality Stds	UNI – EN ISO 9001:2004

## 8 Specification text

### 8 - 1 Specification Text

8

#### Certifications

All units manufactured are CE marked, complying with European directives in force, concerning manufacturing and safety. On request units can be produced complying with laws in force in non European countries (ASME, GOST, etc.), and with other applications, such as naval (RINA, etc.).

#### Versions

EWWD~FZ is available in a High Efficiency version

##### X: High Efficiency

6 sizes to cover a range from 317 up to 1,048 kW (Cooling Capacity), with EER up to 6.00 and ESEER up to 9.60.

The EER (Energy Efficiency Ratio) is the ratio of the Cooling Capacity to the Power Input of the unit. The Power Input includes: the power input for operation of the compressor, the power input of all control and safety devices.

The ESEER (European Seasonal Energy Efficiency Ratio) is a weighed formula enabling to take into account the variation of EER with the load rate and the variation of water inlet condenser temperature.

$$\text{ESEER} = A \times \text{EER}_{100\%} + B \times \text{EER}_{75\%} + C \times \text{EER}_{50\%} + D \times \text{EER}_{25\%}$$

	A	B	C	D
Coefficient	0.03 (3%)	0.33 (33%)	0.41 (41%)	0.23 (23%)
Condenser water inlet temperature (°C)	30	26	22	18

#### Noise Configuration

EWWD~FZ is available in a Standard Noise level configuration:

##### S: Standard Sound

# 8 Specification text

## 8 - 1 Specification Text

### Cabinet and structure

The cabinet is made of galvanized steel sheet and painted to provide a high resistance to corrosion. Colour Ivory White (Munsell code 5Y7.5/1) (±RAL7044).

### Frictionless Centrifugal compressor with magnetic bearings

The frictionless Centrifugal compressor with magnetic bearings and integrated VFD is an innovative compressor that allows great unit efficiency and reliability.

The compressor's one moving part (rotor shaft and impellers) is directly put in rotation by the permanent magnet direct drive motor and kept levitated by a digitally controlled magnetic bearing system; the speed of rotation reduces as the condensing temperature and/or cooling load reduces. Movable inlet guide vanes, activated by step motor, redirect gas flow into the first stage impeller during low loads, after the compressor has reached minimum speed.

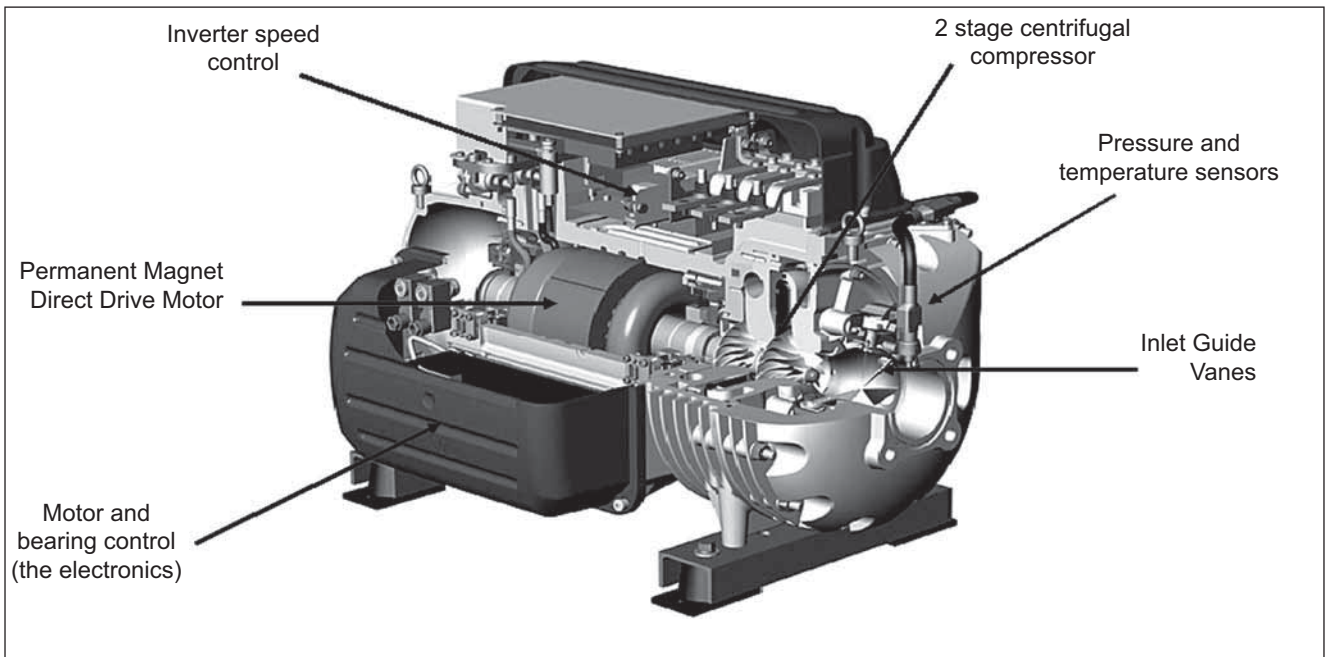

Fig.1

### The Motor

Variable Speed Permanent Magnet Direct Drive Motor (Fig.2), also known as 'brushless', is a synchronous motor, refrigerant cooled and fully protected with thermistors.

Permanent magnets (Fig.3), placed onto the rotor, generate the magnetic flux that is necessary to provide torque.

VFD (Variable Frequency Drive) is required to adjust, depending on the load, the speed of rotation that normally is between 18,000 and 48,000rpm.

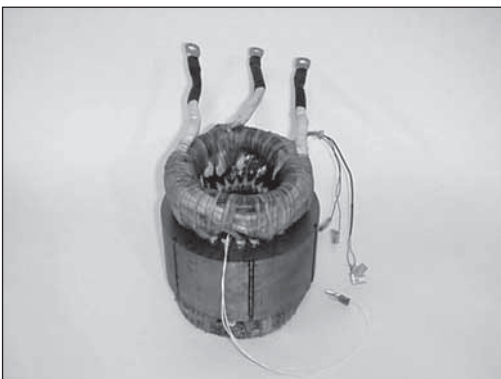

Fig.2

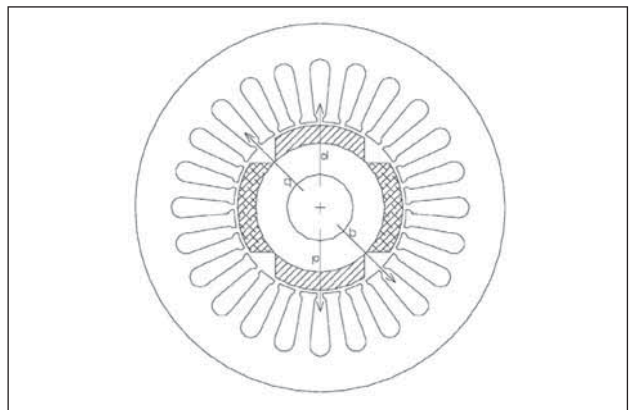

Fig.3

GNC\_1-2-3-4-5-6-7-8\_Rev.00\_1



## 8 Specification text

### 8 - 1 Specification Text

#### The Magnetic bearing system

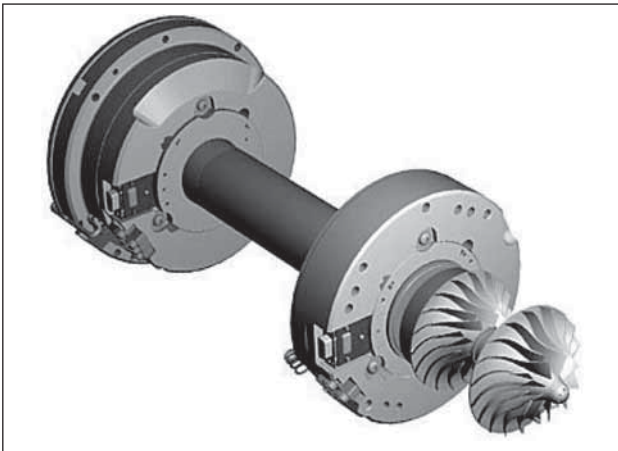

Fig.4

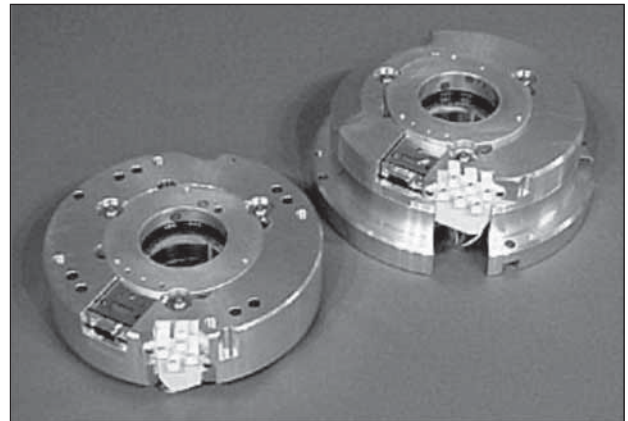

Fig.5

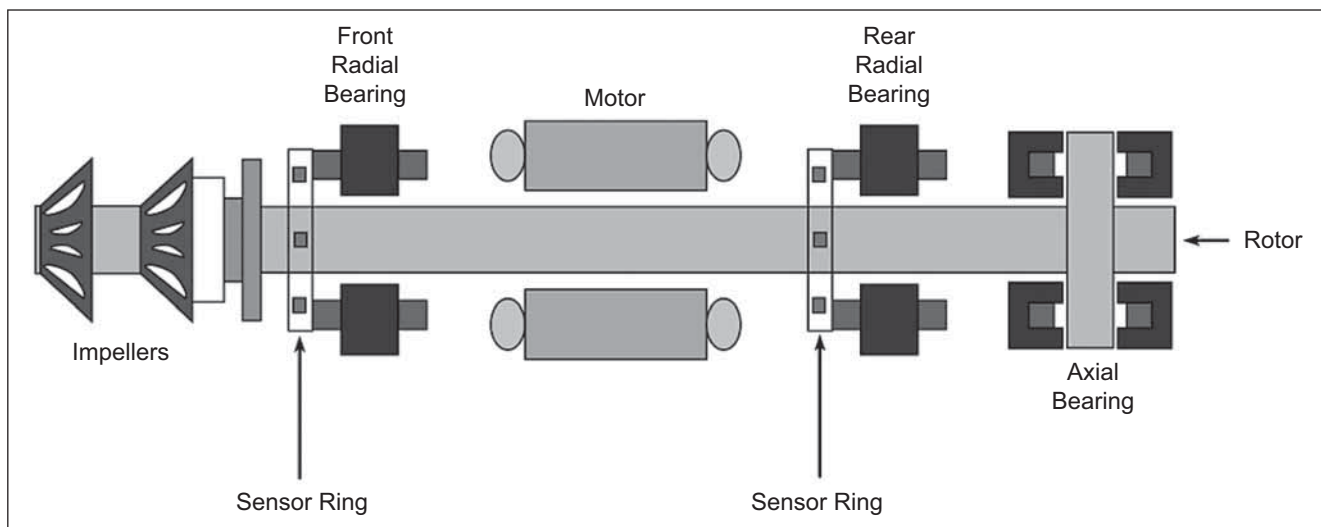

Fig.6

1. The rotor shaft's position is held by front and rear electro-magnetic cushions;
2. The shafts position is monitored with 10 sensors that send a signal to a digital controller which then sends a command to the 5 separate pulse width modulators (PWM), for a proper shaft repositioning;
3. In case of power failure, within 0.5 micro-seconds, the motor acts as a generator for the magnetic bearings and the compressor comes gradually to a complete stop; the rotor de-levitates normally unto backup bearings. Onboard capacitors have enough power to fully support the bearing system during the coast down.

The friction losses and the oil management hardware and controls associated with conventional oil-lubricated bearings are now totally eliminated.

There is no need for oil pumps, oil reservoirs, controls, starter, piping, heaters, oil coolers, oil filters, water regulating valves or oil relief valves that are needed to maintain oil quality. These devices can be a source of problems in traditional chillers, and removing them significantly increases unit reliability and reduces the maintenance.

Modern magnetic bearing technology along with the integrated VFD (variable-speed drive) enables outstanding energy efficiency, especially at partial loads, where significant gains can be realized.

The improvements in terms of efficiency and annual energy cost is maximised when there are long periods of part load operation.

Also the inrush current is strongly reduced thanks to the use of VFD, resulting in an advantageous down-sizing of electrical protection devices.



# 8 Specification text

## 8 - 1 Specification Text

### The Electronics

Inbuilt sophisticated electronics (Fig.7 and 8) guarantee self-diagnostics on Motor, bearings, compressor, expansion valve, performance, events, faults,...and allow the exchange and visibility of data with the chiller controller

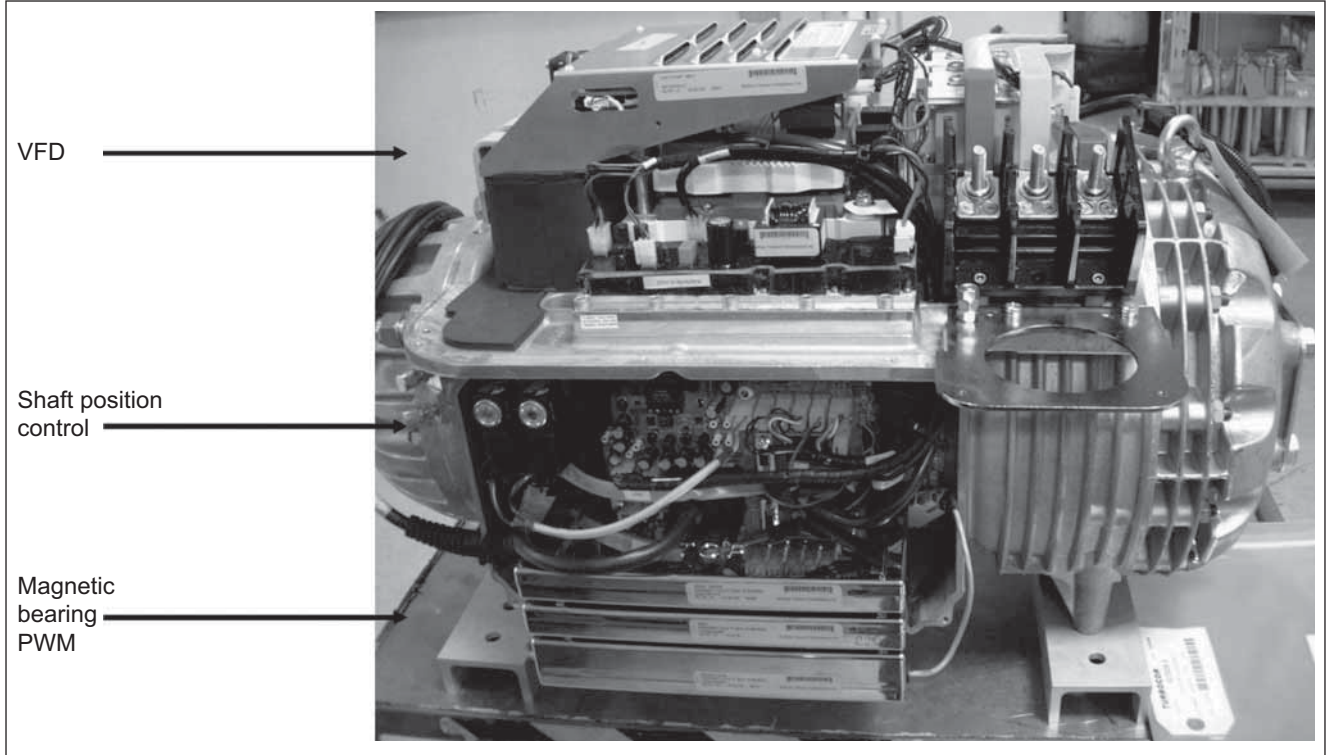

Fig.7

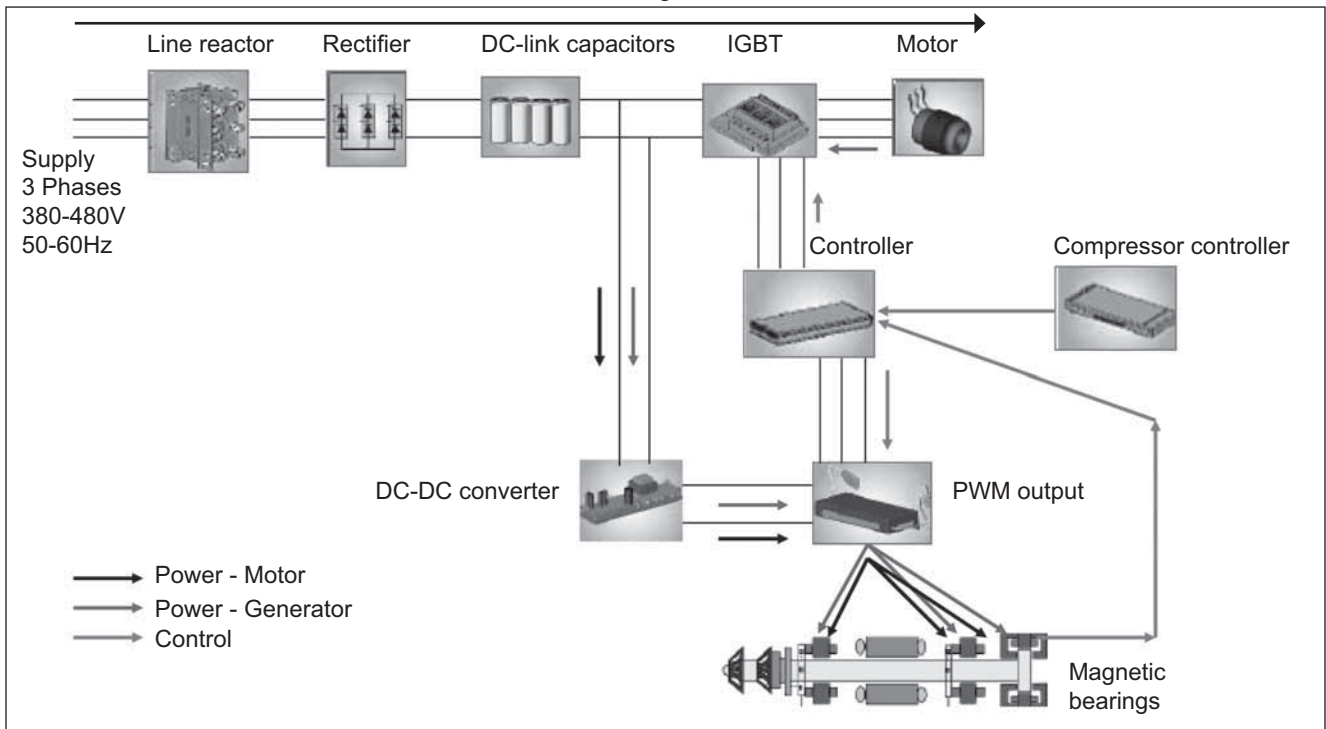

Fig.8

## 8 Specification text

### 8 - 1 Specification Text

8

#### **Ecological R-134a refrigerant**

The compressors have been designed to operate with R-134a, ecological refrigerant with zero ODP (Ozone Depletion Potential) and very low GWP (Global Warming Potential) that means low TEWI (Total Equivalent Warming Impact).

#### **Evaporator**

Flooded shell-and-tube evaporator operating with refrigerant in shell and water in tubes. Replaceable water tubes are fabricated from integral finned copper and mechanically bonded to steel tube sheets. The evaporator is PED designed, constructed, inspected and stamped. Water side working pressure is designed for 10.5 bar. Vessels include 1" NPT spring loaded pressure relief valves. Shell and non-connection water heads are insulated with 3/4" thick closed cell insulation. Standard configuration on water connection side is 2 passes. The evaporator water outlet connections are provided with Victaulic Kit (as standard).

#### **Condenser**

Flooded Shell-and-tube type operating with refrigerant in shell and water in tubes. Replaceable water tubes are fabricated from integral finned copper and mechanically bonded to steel tube sheets. Condenser is designed to conform PED. Water side working pressure is designed for 10.5 bar. Standard configuration on water connections side is 2 passes. The condenser water outlet connections are provided with Victaulic Kit (as standard).

#### **Electronic expansion valve**

The unit is equipped with the most advanced electronic expansion valves to achieve precise control of refrigerant mass flow. As today's system requires improved energy efficiency, tighter temperature control, wider range of operating conditions, the application of electronic expansion valves becomes mandatory. Electronic expansion valves possess unique features: short opening and closing time, high resolution, positive shut-off function to eliminate use of additional solenoid valve, continuous modulation of mass flow without stress in the refrigerant circuit and corrosion resistance stainless steel body.

Electronic Expansion Valves are typically working with lower  $\Delta P$  between high and low pressure side, than a thermostatic expansion valve. The electronic expansion valve allows the system to work with within a wide operating range without any refrigerant flow problems and with a perfect chilled water leaving temperature control.

#### **Refrigerant Circuit**

Each unit has 1 refrigerant circuit including:

- 1 or 2 Compressors
- Electronic expansion valve
- Evaporator
- 1 or 2 ( 1/compressor) safety valve on suction side
- Manometers on evaporator and condenser
- Condenser
- Safety valves on evaporator and condenser
- Water pressure differential switch on evaporator and condenser

#### **Electrical control panel**

Power and control are located in two sections of the main panel that is manufactured to ensure protection against all weather conditions. The electrical panel is IP54 and (when opening the doors) internally protected with Plexiglas panel against possible accidental contact with electrical components (IP20). The main panel is fitted with a main switch interlocked door.

#### **Power Section**

The power section includes circuit breaker, compressors inverters, control circuit transformer.

#### **MicroTech II controller**

The control system of the EWW/D-FZ chiller consists of two major components: the operator interface panel and the unit control panel.

The touch screen panel is on an adjustable arm so that it can be positioned comfortably for the operator.

# 8 Specification text

## 8 - 1 Specification Text

The operator interface panel has a Super VGA touch-screen, utilizing graphics to provide clear and concise information on the chiller status, alarms, trends, and setpoint adjustment. Should the touch-screen become inoperable, the unit and compressor controllers will continue uninterrupted operation of the chiller.

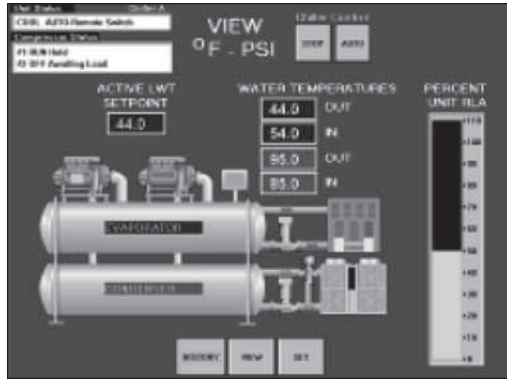

Fig.9

The control panel contains a USB port for downloading the unit's fault history, major parameter trends, and the unit operating manual that is stored in the microprocessor. These design features built into this control system optimize ease of operation, reliability, and efficient operation.

The unit's control panel is featured with the controller, which is responsible for functions involving the single compressors and the entire unit (controlling the electronic expansion valve, for instance) and is the interface point for devices and signals external to the unit.

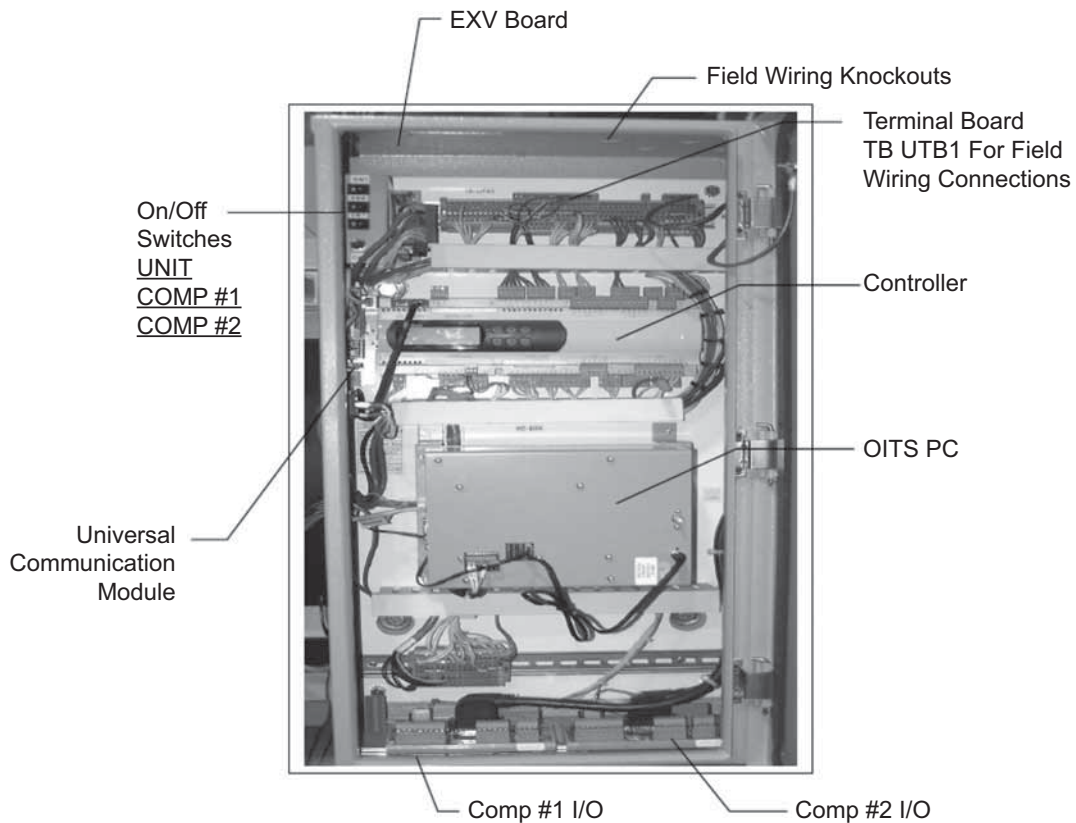

Fig.10

## 8 Specification text

### 8 - 1 Specification Text

8

#### Controller features and benefits

FEATURE	BENEFIT
Easy integration into Building Management System	Designer can select any BAS supplier using standard open protocols and know the MicroTech II control will interface with it.
Easy to read, adjustable, Super VGA colour touch screen operator interface	Operators can observe chiller operation at a glance and easily select various data screens and change setpoints
Historic trend data-downloadable	Water temperatures, refrigerant pressures, and motor load plots can provide valuable information for energy conservation
Precise $\pm 0.2$ °F chilled water control	Provides stability in chilled water system
Proactive pre-shutdown correction of "unusual conditions" allows chiller to stay li	Activates alarm and modifies chiller operation to provide maximum possible cooling
Automatic control of chilled water and condenser water pumps	Integrated lead/lag and automatic engagement of backup pump
Controls up to four stages of tower fans and modulation of tower fan and/ or bypass valve	Optimum integrated, efficient, control of cooling tower water based on system conditions
Twenty-five previous alarm descriptions are stored in memory	Invaluable asset in trouble shooting
Operating and maintenance manuals plus unit parts lists stored in memory	Information instantly available (downloadable) for the life of the unit.
Multiple language capability	Great asset for world-wide applications

Reliable, economic use of any chiller depends largely on an easy operator interface. That's why operation simplicity was one of the main considerations in the development of the MicroTech II controller. The operator's interface with the chiller is through a compact Super VGA color monitor with touch-screen capability. The operator can clearly see the entire chiller graphically displayed with the key operating parameters viewable on the screen. Pressing a single on-screen button will access the set screens where setpoints can be reviewed and changed, if necessary. Other screens, such as alarm history, are easily accessed through touch screen buttons.

By constantly monitoring chiller status, the MicroTech II controller will automatically take proactive measures to relieve abnormal conditions or shut the unit down if a fault occurs. For example, if a problem occurs in the cooling tower and discharge pressure starts to rise, the controller will automatically hold the load point and activate an alarm signal. A further rise in pressure will initiate compressor unloading in an effort to maintain the setpoint pressure and stay online. If the pressure continues to rise, the unit will shut off at the cutout pressure setting.

The MicroTech II controller's memory retains a record of faults and the time/date stamp. The controller's memory (no batteries required) can retain and display the cause of the current fault and the last twenty-five fault conditions. This method for retaining the fault is extremely useful for trouble shooting and maintaining an accurate record of unit performance and history. The controller features a two-level password security system to provide protection against unauthorized use.

## 8 Specification text

### 8 - 1 Specification Text

The Home Screen shown in Figure 8 is usually used as the primary viewing screen. It provides real time data on unit status, water temperatures, chilled water set point and motor amp draw

Many standard features have been incorporated into MicroTech II control in order to maintain the operating economy of EWWD-FZ chillers. In addition to replacing normal relay logic circuits, the controller's energy saving capabilities are enhanced with the following features:

- Direct control of water pumps. Optically isolated, digital output relays provide automatic lead-lag of the evaporator and condenser pumps, permitting pump operation only when required.
- User-programmable compressor soft loading. Prevents excessive power draw during pull down from high unoccupied chilled water temperature conditions.
- Chilled-water reset. Accomplished directly on the unit by resetting the leaving water temperature based on the return water temperature. A remote 4-20 ma or 1-5 VDC BAS signal can also be used to reset the leaving water. Raising the chilled water setpoint during periods of light loads dramatically reduces electrical consumption.
- Demand limit control. Maximum motor current draw can be set on the panel, or can be adjusted from a remote 4-20 ma or 1-5 VDC BAS signal. This feature controls maximum demand charges during high usage periods.
- Condenser water temperature control. Capable of four stages of tower fan control plus an optional analog control of either a three-way tower-bypass valve or variable speed tower-fan motor. Stages are controlled from condenser-water temperature. The three-way valve can be controlled to a different water temperature or track the current tower stage. This allows optimum chilled water plant performance based upon specific job requirements.
- Plotting Historic Trends. Past operation of the chiller can be plotted as trend lines and even downloaded to spread sheets for evaluation - a valuable tool for optimizing efficiency.

#### Connection to BMS

The controller can be connected to BMS (Building Management System) based on the most common protocols as LONWORKS®, BACnet®, or Modbus®; this is possible through serial cards (not included).

#### Standard accessories (supplied on basic unit)

##### Evaporator - 2 passes configuration

**Evaporator Victaulic kit** – Hydraulic joint with gasket for an easy and quick water connection.

**Evaporator water side design pressure 10 bar**

**20mm evaporator insulation**

##### Condenser – 2 passes configuration

**Condenser Victaulic kit** – Hydraulic joint with gasket for an easy and quick water connection.

**Condenser water side design pressure 10 bar**

**Electronic expansion valve**

**High pressure side manometers** on evaporator and condenser

**Water pressure differential switch on evaporator and condenser** - Factory mounted, differential switch is available to detect evaporator and condenser loss of flow.

**Inverter compressor starter** – For low inrush current and reduced starting torque.

**Double pressure relief valve with diverter**

**Current limit** – To limit maximum absorbed current of the unit whenever is required

**Hour run meter**

**General fault contactor**



## 8 Specification text

### 8 - 1 Specification Text

8

**Set-point reset** – The leaving water temperature set-point can be overwritten with the following options: 4-20mA from external source (by user); outside ambient temperature; evaporator water temperature  $\Delta t$ .

**Demand limit** – User can limit the load of the unit by 4-20mA signal or by network system

**Alarm from external device** – Microprocessor is able to receive an alarm signal from an external device (pump etc...). User can decide if this alarm signal will stop the unit or not.

#### Options (on request)

**Evaporator 1/3 passes** – availability of these configurations must be checked on the selection software

**Evaporator flange kit** - Evaporator flanged connections (150 psi) are available instead of the standard victaulic connections

#### Evaporator double flange kit

**Evaporator marine water box** - Evaporator can be furnished with marine water boxes with victaulic or flanged connections (on request). To save time and work marine water boxes cover can be easily removed to clean internal tubes without the disconnection of water pipes.

#### Evaporator water side design pressure 21 bar

**Condenser 1/3 passes** - availability of these configurations must be checked on the selection software

**Condenser flange kit** - Condenser flanged connections (150 psi) are available instead of the standard victaulic connections

#### Condenser double flange kit

**Condenser marine water box** - Evaporator can be furnished with marine water boxes with victaulic or flanged connections (on request). To save time and work marine water boxes cover can be easily removed to clean internal tubes without the disconnection of water pipes.

#### Condenser water side design pressure 21 bar

#### 20mm condenser insulation

**Cu-Ni 90-10 condenser tubes** - To work with sea water the heat exchangers are fitted with Cu-Ni tubes and special protection inside the end covers.

**Evaporator/Condenser Flow switch** – Supplied separately to be wired and installed on the evaporator water piping (by the customer).

**Suction line shut off valve** – Installed on the suction port of the compressor to facilitate maintenance operation.

**Energy Meter** – This device allows to measure the energy absorbed by the chiller during its life. It is installed inside the control box mounted on a DIN rail and show on a digital display: Line-to-Line Voltage, Phase and Average Current, Active and Reactive Power, Active Energy, Frequency.

**Rubber type antivibration mounts** – Supplied separately, these are positioned under the base of the unit during installation. Ideal to reduce the vibrations when the unit is floor mounted.

**Sound proof system** - - Made of sheet metal and internally insulated, the cabinet is “integral kind” ( around the whole chiller, not only around the compressors ) to reach the best performance in noise reduction.

**Witness test** – Every unit is always tested at the test bench prior to the shipment. On request, a second test can be carried out, at customer’s presence, in accordance with the procedures indicated on the test form. (Not available for units with glycol mixtures).

#### Acoustic test

## 8 Specification text

### 8 - 1 Specification Text

#### Technical Specification for Oil Free Centrifugal Water Cooled Chiller

##### GENERAL

The Oil free Centrifugal water cooled chiller will be designed and manufactured in accordance with following European directives:

Construction of pressure vessel	97/23/EC (PED)
Machinery Directive	2006/42/EC
Low Voltage	2006/95/EC
Electromagnetic Compatibility	2004/108/EC
Electrical & Safety codes	EN 60204-1 / EN 60335-2-40
Manufacturing Quality Stds	UNI – EN ISO 9001:2004

The unit will be tested at full load in the factory at the nominal working conditions and water temperatures. Before shipment a full test will be held to avoid any losses.

Chiller will be delivered to the job site completely assembled and charged with right refrigerant.

Comply with the manufacturer instructions for rigging and handling equipment.

The unit will be able to start up and operate as standard at full load and condenser entering fluid temperature from .... °C to .... °C with an evaporator leaving fluid temperature between .... °C and ..... °C

##### REFRIGERANT

Only R-134a will be accepted.

##### PERFORMANCE

- ✓ Number of Oil free Centrifugal water cooled chiller: .....
- ✓ Cooling capacity for single Oil free Centrifugal water cooled chiller: ..... kW
- ✓ Power input for single Oil free Centrifugal water cooled chiller in cooling mode: ..... kW
- ✓ Flooded Shell & tube evaporator entering water temperature in cooling mode: ..... °C
- ✓ Flooded Shell & tube evaporator leaving water temperature in cooling mode: ..... °C
- ✓ Flooded Shell & tube evaporator water flow: ..... l/s
- ✓ Flooded Shell & tube condenser entering water temperature in cooling mode: ..... °C
- ✓ Flooded Shell & tube condenser leaving water temperature in cooling mode: ..... °C
- ✓ Flooded Shell & tube evaporator water flow: ..... l/s
- ✓ Operating voltage range should be 400V ±10%, 3ph, 50Hz, voltage unbalance maximum 3%, without neutral conductor and shall only have one power connection point.

##### UNIT DESCRIPTION

Chiller shall include as standard not less than: one refrigerant circuit, Oil free Centrifugal water cooled compressors (with integrated VFD), electronic expansion device (EEXV), flooded shell & tube heat exchangers, R-134a refrigerant, control system and all components necessary for safe and stable unit operation.

Chiller will be factory assembled, protected by an epoxy paint.

##### SOUND LEVEL AND VIBRATIONS

Sound pressure level at 1 meter distance in free field, semispheric conditions, shall not exceed .....dB(A). The sound pressure levels must be rated in accordance to ISO 3744.

## 8 Specification text

### 8 - 1 Specification Text

8

#### DIMENSIONS

Unit dimensions shall not exceed following indications:

- ✓ unit length ..... mm
- ✓ unit width ..... mm
- ✓ unit height ..... mm

#### CHILLER COMPONENTS

##### Compressors

1. The unit shall utilize magnetic bearing, oil-free, semi-hermetic centrifugal compressors. The compressor drive train shall be capable of coming to a controlled, safe stop in the event of a power failure.
2. The motor shall be of the semi-hermetic type, of sufficient size to efficiently fulfill compressor horsepower requirements. It shall be liquid refrigerant cooled with internal thermal sensing devices in the stator windings. The motor shall be compatible with variable frequency drive operation.
3. The chiller shall be equipped with an integrated Variable Frequency Drive (VFD) to automatically regulate compressor speed in response to cooling load and the compressor pressure lift requirement. Movable inlet guide vanes and variable compressor speed, shall provide unloading. The chiller controls shall coordinate compressor speed and guide vane position to optimize chiller efficiency.
4. Each compressor circuit shall be equipped with a line reactor to help protect against incoming power surges and help reduce harmonic distortion.

##### Evaporator

Water side working pressure is designed for 10,5 bar. Vessels include 1" NPT spring loaded pressure relief valves. Shell and non-connection water heads are insulated with 3/4" thick closed cell insulation. Standard configuration on water connection side is 2 passes.

- ✓ The units will be equipped with a flooded shell-and-tube evaporator operating with refrigerant in shell and water in tubes. Replaceable water tubes are fabricated from integral finned copper and mechanically bonded to steel tube sheets.
- ✓ The evaporator will have 1 circuit and standard configuration on water connection side is 2 passes.
- ✓ The water connections shall be VICTAULIC type connections as standard to ensure quick mechanical disconnection between the unit and the hydronic network.
- ✓ Evaporator is manufactured in accordance to PED approval.

##### Condenser

- ✓ Condenser will be flooded shell-and-tube operating with refrigerant in shell and water in tubes. Replaceable water tubes are fabricated from integral finned copper and mechanically bonded to steel tube sheets.
- ✓ The units will have one condenser on the refrigerant circuit
- ✓ Standard configuration on water connection side is 2 passes.
- ✓ The water connections shall be VICTAULIC type connections as standard
- ✓ Condenser is manufactured in accordance to PED approval.

##### Refrigerant circuit

- ✓ The unit must have one refrigerant circuit.
- ✓ Each circuit shall include as standard: electronic expansion device piloted by unit's microprocessor control, sight glass with moisture indicator and insulated suction line.

##### Control panel

1. The unit shall have a microprocessor-based control system consisting of a 15-inch VGA touch-screen operator interface and a unit controller.



## 8 Specification text

### 8 - 1 Specification Text

2. The touch-screen shall display the unit operating parameters, accept setpoint changes (multi-level password protected) and be capable of resetting faults and alarms. The following parameters shall be displayed on the home screen and also as trend curves on the trend screen:
  - Entering and leaving chilled water temperatures
  - Entering and leaving condenser water temperatures
  - Evaporator saturated refrigerant pressure
  - Condenser saturated refrigerant pressure
  - Percent of 100% speed (per compressor)
  - % of rated load amps for entire unit
3. In addition to the trended items above, all other important real-time operating parameters shall also be shown on the touch-screen. These items shall be displayed on a chiller graphic showing each component. At a minimum, the following critical areas must be monitored:
  - Compressor actual speed, maximum speed, percent speed
  - Evaporator water in and out temperatures, refrigerant pressure and temperature
  - Condenser water in and out temperatures, refrigerant pressure and temperature
  - Liquid line temperature
  - Chilled water setpoint
  - Compressor and unit state and input and output digital and analog values
4. A fault history shall be displayed using an easy to decipher, color coded set of messages that are date and time stamped. The alarm history shall be downloadable from the unit's USB port. An operating and maintenance manual specific for the unit shall be viewable on the screen.
5. All setpoints shall be viewable and changeable (multi-level password protected) on the touch screen and include setpoint description and range of set values.
6. Automatic corrective action to reduce unnecessary cycling shall be accomplished through preemptive control of low evaporator or high discharge pressure conditions to keep the unit operating through abnormal transient conditions.
7. Optionally, the factory mounted controller(s) shall support operation on a BACnet®, Modbus® or LONWORKS® network via one of the data link / physical layers listed below as specified by the successful Building Automation System (BAS) supplier.
  - Modbus
  - BACnet MS/TP master (Clause 9)
  - BACnet IP
  - BACnet ISO 8802-3, (Ethernet)
  - LonTalk® FTT-10A. The unit controller shall be LONMARK® certified.
8. The information communicated between the BAS and the factory mounted unit controllers shall include the reading and writing of data to allow unit monitoring, control and alarm notification as specified in the unit sequence of operation and the unit points list.
9. For chillers communicating over a LONMARK network, the corresponding LONMARK eXternal Interface File (XIF) shall be provided with the chiller submittal data.
10. All communication from the chiller unit controller as specified in the points list shall be via standard BACnet objects. Proprietary BACnet objects shall not be allowed. BACnet communications shall conform to the BACnet protocol. A BACnet Protocol Implementation Conformance Statement (PICS) shall be provided along with the unit submittal.
  - ✓ Field power connection, control interlock terminals, and unit control system should be centrally located in an electric panel (IP 54). Power and starting controls should be separate from safety and operating controls in different compartments of the same panel.
  - ✓ Operating and safety controls should include energy saving control; emergency stop switch; high and low pressure cut-out switch (for each refrigerant circuit); anti-freeze thermostat; cut-out switch for each compressor.
  - ✓ All of the information regarding the unit will be reported on a display and with the internal built-in calendar and clock that will switch the unit ON/OFF during day time all year long.

SPC\_1-2-3-4\_Rev.00\_3

## 8 Specification text

### 8 - 1 Specification Text

8

✓ The following features and functions shall be included:

- leaving water temperature reset by controlling the water temperature  $\Delta t$ , by a remote 4-20mA DC signal or by controlling the external ambient temperature;
- soft load function to prevent the system from operating at full load during the chilled fluid pulldown period;
- password protection of critical parameters of control;
- start-to-start and stop-to-start timers to provide minimum compressor off-time with maximum motor protection;
- communication capability with a PC or remote monitoring;
- discharge pressure control through intelligent cycling of condenser fans;
- lead-lag selection by manual or automatically by circuit run hours;
- double set point for unit version;
- scheduling via internal time clock to allow programming of a yearly start-stop schedule accommodating weekends and holidays.

#### **Optional High Level Communications Interface**

Chiller must be able to communicate to BMS (Building Management System) based on the most common protocols as:

- ModbusRTU
- LonWorks, now also based on the international 8040 Standard Chiller Profile and LonMark Technology
- BacNet BTP certified over IP and MS/TP (class 4) (Native)
- Ethernet TCP/IP.



Daikin's unique position as a manufacturer of air conditioning equipment, compressors and refrigerants has led to its close involvement in environmental issues. For several years Daikin has had the intention to become a leader in the provision of products that have limited impact on the environment. This challenge demands the eco design and development of a wider range of products and an energy management system, resulting in energy conservation and a reduction of waste.



Daikin Europe N.V. participates in the Eurovent Certification programme for Air conditioners (AC), Liquid Chilling Packages (LCP) and Fan coil units (FCU). Check ongoing validity of certificate online: [www.eurovent-certification.com](http://www.eurovent-certification.com) or using: [www.certiflash.com](http://www.certiflash.com)

The present leaflet is drawn up by way of information only and does not constitute an offer binding upon Daikin Europe N.V.. Daikin Europe N.V. has compiled the content of this leaflet to the best of its knowledge. No express or implied warranty is given for the completeness, accuracy, reliability or fitness for particular purpose of its content and the products and services presented therein. Specifications are subject to change without prior notice. Daikin Europe N.V. explicitly rejects any liability for any direct or indirect damage, in the broadest sense, arising from or related to the use and/or interpretation of this leaflet. All content is copyrighted by Daikin Europe N.V.

BARCODE

Daikin products are distributed by: