



Applied Systems Technical Data

Air cooled inverter chiller, high efficiency, low sound



EEDEN13-427

EWAD-BZXL

TABLE OF CONTENTS

EWAD-BZXL

1	Features	2
2	Specifications	3
	Technical Specifications	3
	Electrical Specifications	4
3	Features and advantages	5
	Features and Advantages	5
4	General Characteristics	7
	General characteristics	7
5	Options	12
	Options	12
6	Capacity tables	19
	Cooling Capacity Tables	19
7	Pressure drops	20
	Evaporator Pressure Drops	20
8	Centre of gravity	21
	Centre of Gravity	21
9	Sound data	22
	Sound Level Data	22
10	Installation	25
	Installation Method	25
11	Operation range	28
	Operation Range	28
12	Specification text	33
	Specification Text	33

1 Features

- ESEER up to 5.01
- High efficiency, low sound levels
- High seasonal efficiency
- All models are PED pressure vessel approved
- Inverter stepless single-screw compressor
- Optimised for use with R-134a
- 2 truly independent refrigerant circuits
- DX shell and tube evaporator – one pass refrigerant side to minimize pressure drops
- The ability to vary the output power in direct relation to the cooling requirements of the system allows to achieve building comfort conditions much faster at start-up
- Standard electronic expansion valve
- Partial and total heat recovery option available
- Power factor over 0.95
- Standard operation range down to -12°C



2 Specifications

2-1 Technical Specifications				EWAD330BZ XL	EWAD360BZ XL	EWAD400BZ XL	EWAD420BZ XL	EWAD460BZ XL	EWAD490BZ XL	EWAD520BZ XL	
Cooling capacity	Nom.	kW		328 (1)	357 (1)	394 (1)	422 (1)	458 (1)	486 (1)	513 (1)	
Capacity control	Method			Stepless							
	Minimum capacity		%	13.5							
Power input	Cooling	Nom.	kW		119 (1)	136 (1)	146 (1)	158 (1)	166 (1)	180 (1)	192 (1)
EER				2.75 (1)	2.62 (1)	2.69 (1)	2.66 (1)	2.75 (1)	2.71 (1)	2.67 (1)	
ESEER				4.55	4.59	4.53	4.60	4.59	4.75	4.58	
IPLV				5.76	5.86	5.73	5.87	5.73	5.84	5.78	
Casing	Colour			Ivory white							
	Material			Galvanized and painted steel sheet							
Dimensions	Unit	Height	mm	2,355							
		Width	mm	2,234							
		Depth	mm	4,381	5,281			6,181			
Weight	Unit		kg	4,340	4,740			5,140			
	Operation weight		kg	4,590	4,990			5,390			
Water heat exchanger	Type			Single pass shell & tube							
	Water volume		l	271	264		256		248		
	Nominal water flow	Cooling	l/s	15.7	17.1	18.8	20.2	21.9	23.3	24.6	
	Nominal water pressure drop	Cooling	Heat exchanger	kPa	40	37	44	40	38	43	47
	Insulation material			Closed cell							
Air heat exchanger	Type			High efficiency fin and tube type with integral subcooler							
Fan	Quantity			8		10		12			
	Type			Direct propeller							
	Diameter		mm	800							
	Air flow rate	Nom.	l/s	32,700	42,899	41,887	51,478	50,264	49,050		
	Speed		rpm	705							
Fan motor	Drive			Brushless							
	Input	Cooling	W	7,300	9,100		10,900				
Sound power level	Cooling	Nom.	dBA		97			98			
Sound pressure level	Cooling	Nom.	dBA		77			78			
Compressor	Type			Semi-hermetic single screw compressor							
	Quantity			2							
	Oil	Charged volume		l	26						
Operation range	Water side	Cooling	Min.	°CDB	-9.5						
			Max.	°CDB	15						
	Air side	Cooling	Min.	°CDB	-12						
			Max.	°CDB	45						
Refrigerant	Type			R-134a							
	Charge		kg	73	99	105	114	118	121		
	Circuits	Quantity		2							
Piping connections	Evaporator water inlet/outlet (OD)			168.3mm							
Safety devices	Item	01		High discharge pressure (pressure switch)							
		02		High discharge pressure (pressure transducer)							
		03		Low suction pressure (pressure transducer)							
		04		Compressor overload (Kriwan)							
		05		High discharge temperature							
		06		Low oil pressure							
		07		Low pressure ratio							
		08		High oil filter pressure drop							
		09		Phase monitor							

2 Specifications

2-2 Electrical Specifications				EWAD330BZ XL	EWAD360BZ XL	EWAD400BZ XL	EWAD420BZ XL	EWAD460BZ XL	EWAD490BZ XL	EWAD520BZ XL
Compressor	Phase			3~						
	Voltage		V	400						
	Voltage range	Min.	%	-10						
		Max.	%	10						
	Maximum running current		A	150				180		
Starting method			VFD driven							
Compressor 2	Maximum running current		A	150				180		
Power supply	Phase			3~						
	Frequency		Hz	50						
	Voltage		V	400						
	Voltage range	Min.	%	-10						
		Max.	%	10						
Unit	Maximum starting current		A	232	244	251	278	297	302	316
	Nominal running current (RLA)	Cooling	A	183	209	225	244	256	275	295
		Power factor		A	0.98					
	Maximum running current		A	311		314	344	377		
	Max unit current for wires sizing		A	342		345	378	414		
Fans	Nominal running current (RLA)		A	11.2		14		16.8		

Notes

- (1) Cooling: entering evaporator water temp. 12°C; leaving evaporator water temp. 7°C; ambient air temp. 35°C; full load operation.
- (2) Cooling: entering evaporator water temp. 12°C; leaving evaporator water temp. 7°C; ambient air temp. 35°C; full load operation; Standard: ISO3744
- (3) Allowed voltage tolerance ± 10%. Voltage unbalance between phases must be within ± 3%.
- (4) Maximum starting current: starting current of biggest compressor + 75 % of maximum current of the other compressor + fans current for the circuit at 75 %
- (5) Cooling: entering evaporator water temp. 12°C; leaving evaporator water temp. 7°C; ambient air temp. 35°C. Compressor + fans current.
- (6) Maximum running current is based on max compressor absorbed current in its envelope and max fans absorbed current
- (7) Maximum current for wires sizing: (compressors full load ampere + fans current) x 1.1

3 Features and advantages

3 - 1 Features and Advantages

High part load efficiency

EWAD~BZ is the result of careful design, aimed to optimizing the energy efficiency of the chillers, with the objective of bringing down operating costs and improving installation profitability, effectiveness and economical management.

Per European Seasonal Energy Efficiency Ratio (ESEER), chillers operate at design conditions only three percent of the time. As a result better part load efficiencies are required at part load conditions in a chiller water applications. EWAD~BZ maximize chiller efficiency by optimizing single screw compressor operation dramatically reducing the electric power consumption when the motor speed slows.

Seasonal quietness

Very low noise levels in part load conditions are achieved by varying the fan speed, but especially thanks to the variation of compressor frequency, which ensure the minimum noise level at all the time.

Quick comfort conditions

The ability to vary the output power in direct relation to the cooling requirements of the system, allow the possibility to achieve building comfort conditions much faster at start-up.

Low starting current

No current spikes at start-up. The starting current is always lower than current absorbed in the maximum operating conditions (FLA).

Power factor always > 0.95

EWAD~BZ can operate always > 0.95 power factor, which can allows building owners avoid power factor penalties and decreases electrical losses in cable and transformers.

Redundancy

EWAD~BZ has two independent refrigerant circuits in every size, in order to assure maximum safety for any maintenance, whether planned or not.

Infinitely capacity control

Cooling capacity control is infinitely variable by means of an Inverter driven screw compressor controlled by a microprocessor system. Each unit has infinitely variable capacity control from 100% down to 13,5%. This modulation allows the compressor capacity to exactly match the building cooling load without any leaving evaporator water temperature fluctuation. This chilled water temperature fluctuation is avoided only with a stepless control.

With a compressor load step control in fact, the compressor capacity, at partial loads, will be too high or too low compared to the building cooling load. The result is an increase in chiller energy costs, particularly at the part-load conditions at which the chiller operates most of the time.

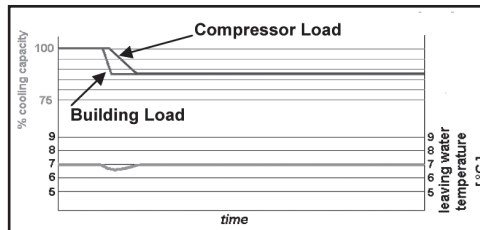
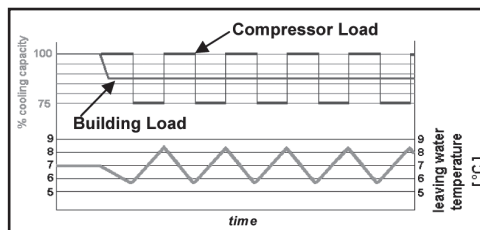

Units with stepless regulation offer benefits that the units with step regulation are unable to match. The ability to follow the system energy demand at any time and the possibility to provide steady outlet water temperature without deviations from the set-point, are the two points that allow you to understand how the optimum operating conditions of a system can be met only through the use of a unit with stepless regulation.

3 Features and advantages

3 - 1 Features and Advantages

3

Code requirements – Safety and observant of laws/directives

All EWAD-BZ- units are designed and manufactured in accordance with applicable selections of the following:

Rating of chillers	EN 12055
Construction of pressure vessel	97/23/EC (PED)
Machinery Directive	98/37/EC as modified
Low Voltage	2006/95/EC
Electromagnetic Compatibility	2004/108/EC
Electrical & Safety codes	EN 60204-1 / EN 60335-2-40
Manufacturing Quality Stds	UNI – EN ISO 9001:2000

Certifications

All units manufactured are CE marked, complying with European directives in force, concerning manufacturing and safety. On request units can be produced complying with laws in force in non European countries (ASME, GOST, etc.), and with other applications, such as naval (RINA, etc.).

Versions

EWAD-BZ is available in the following versions:

S: Standard Efficiency

7 sizes to cover a range from 329 up to 515 kW with an ESEER up to 4.70

X: High Efficiency

7 sizes to cover a range from 329 up to 515 kW with an ESEER up to 5.01

The EER (Energy Efficiency Ratio) is the ratio of the Cooling Capacity to the Power Input of the unit. The Power Input includes: the power input for operation of the compressor, the power input of all control and safety devices, the power input for fans.

The ESEER (European Seasonal Energy Efficiency Ratio) is a weighed formula enabling to take into account the variation of EER with the load rate and the variation of air inlet condenser temperature.

$$ESEER = A \times EER_{100\%} + B \times EER_{75\%} + C \times EER_{50\%} + D \times EER_{25\%}$$

	A	B	C	D
Coefficient	0.03 (3%)	0.33 (33%)	0.41 (41%)	0.23 (23%)
Air inlet condenser temperature	35°C	30°C	25°C	20°C

Noise Configuration

EWAD-BZ is available in two or three different noise level configurations:

S: Standard Noise

Condenser fan rotating at 700 rpm, rubber antivibration on compressor

L: Low Noise

Condenser fan rotating at 700 rpm, rubber antivibration on compressor, sound proof cabinet for each compressor

R: Reduced Noise

Condenser fan rotating at 700 rpm, rubber antivibration on compressor, one sound proof cabinet for compressor and evaporator, suction muffler

4 General Characteristics

4 - 1 General characteristics

Cabinet and structure

The cabinet is made of galvanized steel sheet and painted to provide a high resistance to corrosion. Colour Ivory White (Munsell code 5Y7.5/1) (\pm RAL7044). The base frame has eye-hook for lifting the unit with ropes for an easy installation. The weight is uniformly distributed along the profiles of the base and this facilitates the arrangement of the unit.

Screw compressors with integrated oil separator

The compressors are semi-hermetic, single-screw type with gate-rotor (made of carbon impregnated engineered composite material). Each compressor has one inverter managed by the unit microprocessor for infinitely modulating the capacity. An integrated high efficiency oil separator maximises the oil separation.

Start is inverter type.

Ecological R-134a refrigerant

The compressors have been designed to operate with R-134a, ecological refrigerant with zero ODP (Ozone Depletion Potential) and very low GWP (Global Warming Potential) that means low TEWI (Total Equivalent Warming Impact).

Evaporator

The units are equipped with a Direct Expansion shell&tube evaporator with copper tubes rolled into steel tubesheets. The evaporators are single-pass on both the refrigerant and water sides for pure counter-flow heat exchange and low refrigerant pressure drops. Both attributes contribute to the heat exchanger effectiveness and total unit's outstanding efficiency.

The external shell is covered with a 10mm closed cell insulation material. Each evaporator has 2 circuits, one for each compressor and is manufactured in accordance to PED approval. The evaporator water outlet connections are provided with Victaulic Kit (as standard).

Condenser coils

The condenser is manufactured with internally enhanced seamless copper tubes arranged in a staggered row pattern and mechanically expanded into lanced and rippled aluminium condenser fins with full fin collars. An integral sub-cooler circuit provides sub-cooling to effectively eliminate liquid flashing and increase in cooling capacity without increasing the power input.

Condenser coil fans (version EWAD-BZSS / SL and EWAD-BZXS / XL)

The condenser fans are propeller type with high efficiency design blades to maximize performances. The material of the blades is glass reinforced resin and each fan is protected by a guard. Fan motors are protected by circuit breakers installed inside the electrical panel as a standard. The motors are IP54 and are suitable for use with PWM-operated inverters.

Condenser coil fans (version EWAD-BZXR)

The condenser fans are "brushless" propeller type and are made with synchronous motors excited by permanent magnets and with phase currents controlled by a PWM inverter integrated in the fan motor housing, that allows operation at different speeds. With this technology the fans reach high efficiencies with an extremely low noise level across a very wide speed range.

4 General Characteristics

4 - 1 General characteristics

4

Electronic expansion valve

The unit is equipped with the most advanced electronic expansion valves to achieve precise control of refrigerant mass flow. As today's system requires improved energy efficiency, tighter temperature control, wider range of operating conditions and incorporate features like remote monitoring and diagnostics, the application of electronic expansion valves becomes mandatory. Electronic expansion valve proposes features that make it unique: short opening and closing time, high resolution, positive shut-off function to eliminate use of additional solenoid valve, continuous modulation of mass flow without stress in the refrigerant circuit and corrosion resistance stainless steel body.

Electronic Expansion Valves are typically working with lower ΔP between high and low pressure side, than a thermostatic expansion valve. The electronic expansion valve allows the system to work with low condenser pressure (winter time) without any refrigerant flow problems and with a perfect chilled water leaving temperature control.

Refrigerant Circuit

Each unit has 2 independent refrigerant circuits and each one includes:

- Compressor with integrated oil separator
- Air Cooled Condenser
- Electronic expansion valve
- Evaporator
- Discharge line shut off valve
- Liquid line shut off valve
- Suction line shut off valve
- Sight glass with moisture indicator
- Filter drier
- Charging valves
- High pressure switch
- High and low pressure transducers

Electrical control panel

Power and control are located in two sections of the main panel that is manufactured to ensure protection against all weather conditions. The electrical panel is IP54 and (when opening the doors) internally protected with Plexiglas panel against possible accidental contact with electrical components. The main panel is fitted with a main switch interlocked door.

Power Section

The power section includes circuit breaker, compressors inverters, fans contactors, fans thermal overload relays, fans inverter and control circuit transformer.

MicroTech II controller

MicroTech II C Plus controller is installed as standard; it can be used to modify unit set-points and check control parameters. A built-in display shows machine's operating status, programmable values, set-points, like temperatures and pressures of water, refrigerant and air. Device controls maximise the chiller energy efficiency and the reliability. A sophisticated software with predictive logic, select the most energy efficient combination of compressors, EEXV and condenser fans to keep stable operating conditions and maximise energy efficiency. The compressors are automatically rotated to ensure equal operating hours. MicroTech II C Plus protects critical components in response to external signals from its system sensors measuring: motor temperatures, refrigerant gas and oil pressures, correct phase sequence and evaporator.

4 General Characteristics

4 - 1 General characteristics

Control section - main features

- Management of the compressor capacity, Inverter, slide and fans modulation.
- Chillers enabled to work in partial failure condition.
- Full routine operation at condition of:
 - high ambient temperature value,
 - high thermal load,
 - high evaporator entering water temperature (start-up).
- Display of evaporator entering/leaving water temperature.
- Display of condensing-evaporating temperature and pressure, suction and discharge superheat for each circuit.
- Leaving water cooled temperature regulation. Temperature tolerance = 0,1°C.
- Compressors and evaporator pumps hours counter.
- Display of Status Safety Devices.
- Start up numbers and compressors working hours equalization.
- Optimized management of compressors load.
- Fans management according to condensing pressure.
- Automatic re-start in case of power supply interruption (adjustable).
- Soft Load.
- Start at high evaporator water temperature.
- Return Reset.
- AOT Reset (optional).
- Set point Reset (optional).

Safety device / logic for each refrigerant circuit

- High pressure (pressure switch).
- Low pressure (transducer).
- Condensation fan Magneto-thermal.
- High Discharge Temperature on the compressor.
- Phase Monitor.
- Low pressure ratio.
- High oil pressure drop.
- Low oil pressure.

System security

- Phase monitor.
- Freeze protection.

Regulation type

Proportional + integral + derivative regulation on the leaving water evaporator output probe.

Condensing pressure

The condensation can be carried out according to temperature or pressure or pressure ratio. The fans can be managed according to a 0/10 V modulating signal.

Intelligent Compressor Start Mode

Control software includes an intelligent compressor start mode that unloads the first compressor to 75% during the start of the second one, in order to reduce inrush current.

4 General Characteristics

4 - 1 General characteristics

MicroTech II C Plus terminal

MicroTech II C Plus built-in terminal has the following features.

- 4-lines by 20-character liquid crystal display back lighting.
- Key-pad consisting of 6 keys.
- Memory to protect the data.
- General faults alarm relays.
- Password access to modify the setting.
- Service report displaying all running hours and general conditions.
- Alarm history memory to allow an easy fault analysis.

Supervising systems (on request)

MicroTech II C Plus remote control

MicroTech II C Plus is able to communicate to BMS (Building Management System) based on the most common protocols as:

- CARELNative
- ModbusRTU
- LonWorks, now also based on the international 8040 Standard Chiller Profile and LonMark Technology
- BacNet BTP certified over IP and MS/TP (class 4)
- Ethernet TCP/IP and SNM.

Standard accessories (supplied on basic unit)

Double set-point – Dual leaving water temperature set-points.

Fans circuit breaker with thermal overload relays – Safety devices against motor overloading and short circuit in addition to the normal protection envisaged by the electrical windings.

Phase monitor – The phase monitor controls that phases sequence is correct and controls phase loss.

Inverter compressor starter – For low inrush current and reduced starting torque.

Evaporator Victaulic kit on water connection – Hydraulic joint with gasket for an easy and quick water connection.

Fan Silent Mode - The microprocessor clock switches the fan at low speed according to the client setting (i.e. Night & Day), providing that the ambient temperature/condensing pressure is allowing the speed change.

Fan speed regulation – To control the fan speed revolution for smooth operating control of the unit. This option improves the sound level of the unit during low ambient temperature operation.

10mm evaporator insulation

Evaporator electric heater – Electric heater controlled by a thermostat to protect the evaporator from freezing down to -28°C ambient temperature, providing the power supply is on.

Electronic expansion valve

Discharge line shut off valves – Installed on the discharge port of the compressor to facilitate maintenance operation.

Suction line shut off valve – Installed on the suction port of the compressor to facilitate maintenance operation.

Compressor hour run meter

General fault – Alarm relay.

Main switch interlock door

4 General Characteristics

4 - 1 General characteristics

Options (on request)

Total heat recovery – Produced with shell and tube heat exchangers to produce hot water up to +55°C. The heat exchanger is mounted on both the refrigerant circuits (2 refrigerant circuits) parallel to the condenser coils to remove all the condensation heat.

Total heat recovery 1 circuit – Produced with shell and tube heat exchangers to produce hot water up to +55°C. The heat exchanger is mounted on one refrigerant circuit parallel to the condenser coils to remove all the condensation heat.

Partial heat recovery – Produced with plate to plate heat exchangers installed between the compressor discharge and the condenser coil, allowing to produce hot water.

Brine version – Allows the unit to operate down to -8°C leaving liquid temperature (antifreeze required).

Under/Over Voltage – This device controls the voltage value of power supply and stops the chiller if the value exceeds the allowed operating limits.

Energy Meter – This device allows to measure the energy absorbed by the chiller during its life. It is installed inside the control box mounted on a DIN rail and show on a digital display: Line-to-Line Voltage, Phase and Average Current, Active and Reactive Power, Active Energy, Frequency.

Current limit – To limit maximum absorbed current of the unit whenever is required

20mm evaporator insulation

Condenser coil guards

Cu-Cu condensing coils – To give better protection against corrosion by aggressive environments.

Cu-Cu-Sn condensing coils – To give better protection against corrosion in aggressive environments and by salty air.

Alucoat condensing coils – Fins are protected by a special acrylic paint with a high resistance to corrosion.

Evaporator Flow switch – Supplied separately to be wired and installed on the evaporator water piping (by the customer).

High pressure side manometers

Low pressure side manometers

Kit container

Rubber type antivibration mounts – Supplied separately, these are positioned under the base of the unit during installation. Ideal to reduce the vibrations when the unit is floor mounted.

Spring type antivibration mounts – Supplied separately, these are positioned under the base of the unit during installation. Ideal for dampening vibrations for installation on roofs and metallic structures.

Water circulation pump (low or high lifting) – Hydronic kit consists of: single direct driven centrifugal pump, water filling system with pressure gauge, safety valve, drain valve. The motor pump is protected by a circuit breaker installed in control panel. The kit is assembled and wired to the control panel. The pipe and pump are protected from freezing with an additional electrical heater.

Two water circulation pumps (low or high lifting) – Hydronic kit consists of: twin direct driven centrifugal pumps, water filling system with pressure gauge, safety valve, drain valve. The motor pump is protected by a circuit breaker installed in control panel. The kit is assembled and wired to the control panel. The pipe and pumps are protected from freezing with an additional electrical heater.

Inertial tank with cabinet (500 l or 1,000 l) – Piping to unit are not included and electric heater power supply has to be provided from external source.

Witness test – Every unit is always tested at the test bench prior to the shipment. On request, a second test can be carried out, at customer's presence, in accordance with the procedures indicated on the test form. (Not available for units with glycol mixtures).

Set-point reset, demand limit and alarm from external device – The leaving water temperature set-point can be overwritten with the following options: 4-20mA from external source (by user); outside ambient temperature; evaporator water temperature Δt . Moreover the device allow the user to limit the load of the unit by 4-20mA signal or by network system and the microprocessor is able to receive an alarm signal from an external device (pump etc... - user can decide if this alarm signal will stop or not the unit).

Double pressure relief valve with diverter

GNC_1-2-3-4a-5a_Rev.01_5a

5 Options

5 - 1 Options

5

EWAD-BZ

Total heat recovery ratings

Size	ELWT (°C)	Heat Recovery Water Temperature (°C)															
		30/35			35/40			40/45			45/50			50/55			
		Rated			Rated			Rated			Rated			Rated			
	Cc (kW)	Pi (kW)	Hc (kW)	Cc (kW)	Pi (kW)	Hc (kW)	Cc (kW)	Pi (kW)	Hc (kW)	Cc (kW)	Pi (kW)	Hc (kW)	Cc (kW)	Pi (kW)	Hc (kW)		
330	4	321	84.5	405	305	93.9	399	287	105	392	266	118	383	178	82.7	261	
	5	331	85.3	417	315	94.8	410	297	106	402	275	119	394	179	80.2	260	
	6	342	86.1	428	326	95.7	421	307	107	413	284	120	404	180	77.8	258	
	7	353	86.9	440	336	96.6	433	317	108	424	294	121	414	184	77.0	261	
	8	365	87.7	452	347	97.5	445	327	109	436	303	122	425	184	74.6	258	
	9	376	88.5	464	358	98.4	456	337	110	447	313	123	436	187	73.9	261	
	10	388	89.3	477	369	99.3	468	348	111	459	323	124	447	186	71.5	258	
	11	399	90.1	489	380	100	481	359	112	470	333	125	459	189	70.7	259	
	12	411	90.9	502	392	101	493	370	113	482	344	126	470	191	69.9	261	
	13	423	91.7	515	403	102	506	381	114	494	351	125	476	189	67.4	257	
	14	436	92.5	528	415	103	518	392	115	507	354	122	476	191	66.6	258	
	15	448	93.3	542	427	104	531	403	116	519	358	119	477	193	65.7	259	
	360	4	356	94.2	450	338	105	442	317	117	434	293	131	425	187	85.9	273
		5	367	95.1	462	349	106	455	328	118	446	304	132	436	191	85.1	276
		6	379	96.0	475	361	107	467	339	119	458	314	134	447	191	82.4	274
7		392	97.0	489	372	108	480	350	120	470	324	135	459	193	80.7	274	
8		404	97.9	502	384	109	493	362	121	483	335	136	471	197	79.9	277	
9		417	98.8	515	396	110	506	373	123	496	346	137	483	196	77.3	273	
10		429	99.7	529	409	111	520	385	124	508	355	137	492	199	76.4	275	
11		443	101	543	421	112	533	397	125	521	362	136	498	201	75.5	277	
12		456	102	557	434	113	547	409	126	535	370	135	504	199	72.8	271	
13		469	103	572	447	114	561	421	127	548	374	131	505	201	71.9	273	
14		483	104	586	460	115	575	433	129	562	378	128	505	202	70.9	273	
15		497	104	601	473	116	589	446	130	575	381	125	506	204	70.0	274	
400		4	386	104	489	367	115	482	344	129	473	318	145	463	197	90.7	288
		5	399	105	503	379	116	495	356	130	486	329	146	475	201	89.7	291
		6	411	106	517	391	117	509	368	131	499	340	147	487	201	86.9	288
	7	425	107	531	404	119	522	380	132	512	351	148	500	205	85.9	291	
	8	438	108	546	416	120	536	392	134	525	363	150	513	208	85.0	293	
	9	451	109	560	429	121	550	404	135	539	374	151	526	207	82.1	289	
	10	465	110	575	443	122	565	417	136	553	383	150	532	210	81.2	291	
	11	479	111	590	456	123	579	429	138	567	387	146	533	212	80.2	293	
	12	493	112	605	470	125	594	442	139	581	391	142	533	209	77.3	286	
	13	508	113	621	483	126	609	455	140	595	395	139	534	211	76.2	287	
	14	523	114	637	497	127	624	468	142	610	399	135	534	213	75.2	288	
	15	538	115	653	511	128	640	482	143	625	403	132	535	214	74.1	288	
	420	4	415	112	527	394	125	519	370	139	509	341	156	497	207	95.5	303
		5	429	113	542	407	126	533	382	141	523	353	158	510	209	93.4	303
		6	443	115	557	420	127	548	395	142	537	365	159	524	211	91.4	303
7		457	116	572	434	129	562	408	143	551	377	161	537	212	89.3	302	
8		471	117	588	448	130	577	421	145	565	387	161	548	213	87.3	301	
9		486	118	604	462	131	593	434	146	580	395	159	554	216	86.3	303	
10		501	119	620	476	132	608	447	148	595	402	156	558	219	85.3	304	
11		516	120	636	490	134	624	461	149	610	407	152	559	219	83.3	302	
12		531	122	652	505	135	640	475	151	625	411	148	559	218	81.1	299	
13		546	123	669	519	137	656	489	152	641	413	143	557	219	80.0	299	
14		562	124	686	534	138	672	503	154	656	417	140	557	221	78.8	300	
15		578	125	703	550	139	689	517	155	672	421	136	557	222	77.6	299	

NOTES

Cc (cooling capacity) - Pi (unit power input) - ELWT (evaporator leaving water temperature - Δt 5°C).
 Data are referred to 0.0176 m² °C/kW evaporator fouling factor
 Rated conditions are for compressors running at nominal frequency.

5 Options

5 - 1 Options

EWAD~BZ

Total heat recovery ratings

Size	ELWT (°C)	Heat Recovery Water Temperature (°C)															
		30/35			35/40			40/45			45/50			50/55			
		Rated			Rated			Rated			Rated			Rated			
	Cc (kW)	Pi (kW)	Hc (kW)	Cc (kW)	Pi (kW)	Hc (kW)	Cc (kW)	Pi (kW)	Hc (kW)	Cc (kW)	Pi (kW)	Hc (kW)	Cc (kW)	Pi (kW)	Hc (kW)		
460	4	443	121	563	420	134	554	394	150	543	363	168	531	217	100	317	
	5	457	122	579	434	136	569	407	151	558	375	170	545	217	96.9	314	
	6	472	123	595	448	137	585	420	153	573	388	171	559	221	95.9	316	
	7	487	124	611	462	138	601	434	154	588	400	173	573	219	92.6	312	
	8	502	126	628	477	140	617	448	156	603	410	171	581	222	91.5	314	
	9	518	127	645	492	141	633	462	157	619	415	167	581	225	90.4	316	
	10	534	128	662	507	143	649	476	159	635	420	162	582	228	89.3	317	
	11	550	130	679	522	144	666	490	161	651	425	158	583	224	86.0	310	
	12	566	131	697	537	146	683	505	162	667	429	154	583	226	84.8	311	
	13	582	132	714	553	147	700	520	164	684	433	150	584	227	83.6	311	
	14	599	134	732	569	149	718	535	166	700	437	147	584	229	82.4	311	
	15	616	135	751	585	150	735	550	167	717	441	143	584	229	81.1	310	
	490	4	472	130	602	448	145	592	420	161	581	382	178	560	227	105	332
		5	488	131	619	463	146	609	434	163	597	395	179	575	226	102	328
		6	503	133	636	478	148	625	448	165	612	407	179	586	230	101	331
7		519	134	653	493	149	642	462	166	629	420	181	601	231	98.2	329	
8		536	136	671	508	151	659	477	168	645	430	179	609	235	97.1	332	
9		552	137	689	524	152	676	492	170	661	435	175	610	234	94.6	329	
10		569	138	707	540	154	694	507	171	678	438	169	607	237	93.4	330	
11		586	140	726	556	155	712	522	173	695	443	164	607	236	91.1	327	
12		603	141	744	573	157	730	538	175	713	448	160	608	238	89.9	328	
13		621	143	763	589	159	748	553	177	730	452	156	608	239	88.6	328	
14		638	144	782	606	160	766	567	177	743	456	152	608	240	87.3	327	
15		656	146	802	623	162	785	583	179	761	459	148	608	241	85.9	327	
520		4	500	139	639	474	155	629	444	173	617	401	187	588	236	110	346
		5	516	141	657	490	156	646	459	174	633	415	189	603	235	106	342
		6	533	142	675	505	158	663	474	176	650	424	187	611	239	105	344
	7	549	144	693	521	160	681	489	178	667	438	189	627	243	104	347	
	8	566	145	711	538	161	699	504	180	684	448	187	635	246	103	349	
	9	584	147	730	554	163	717	520	182	702	454	182	636	243	98.8	342	
	10	601	148	749	571	165	736	536	183	719	459	177	636	245	97.5	343	
	11	619	150	769	588	166	754	552	185	737	464	173	637	247	96.2	344	
	12	637	151	788	605	168	773	568	187	755	469	169	637	249	94.9	344	
	13	656	153	808	623	170	792	584	189	774	473	164	637	250	93.5	344	
	14	674	154	829	640	172	812	596	188	783	477	160	637	251	92.1	343	
	15	693	156	849	658	173	832	612	190	802	480	156	637	252	90.6	342	

NOTES

Cc (cooling capacity) - Pi (unit power input) – ELWT (evaporator leaving water temperature – Δt 5°C).

Data are referred to 0.0176 m² °C/kW evaporator fouling factor

Rated conditions are for compressors running at nominal frequency.

5 Options

5 - 1 Options

5

EWAD-BZ

Total heat recovery pressure drops

Size	330	360	400	420	460	490	520
Heating Capacity (kW)	424	470	512	551	588	629	667
Water Flow (l/s)	20.47	22.47	24.45	26.32	28.09	30.03	31.86
Heat Recovery Pressure Drops (kPa)	55	65	55	62	60	65	65

Water flow and pressure drop referred to nominal condition: evaporator water in/out: 12/7°C – water heat recovery in/out 40/45°C

OPT_1-2-3-4-5-6-7_Rev.00_3

EWAD-BZ

Partial Heat Recovery Ratings

EWAD-BZSS/SL EWAD-BZXS/XL/XR	Evaporator Leaving Temperature 7°C - Δt 5°C	Condenser Inlet Air 35°C	Partial Heat Recovery Leaving Water Temperature (°C)			Partial Heat Recovery LWT 45°C	
			45 (Δt=5°C)	50 (Δt=5°C)	55 (Δt=5°C)	Water Flow l/s	Pressure Drops kPa
330			Hc (kW)	Hc (kW)	Hc (kW)		
360			86	69	52	4.11	40
400			95	76	57	4.54	50
420			104	83	62	4.97	39
460			112	90	67	5.35	45
490			120	96	72	5.73	52
520			128	102	77	6.12	60
			136	109	82	6.50	43

OPT_1-2-3-4-5-6-7_Rev.00_4

5 Options

5 - 1 Options

EWAD-BZ

Total and partial heat recovery pressure drops

To determine the pressure drop for different versions or at different working condition, please refer to the following formula:

$$PD_2 \text{ (kPa)} = PD_1 \text{ (kPa)} \times \left(\frac{Q_2 \text{ (l/s)}}{Q_1 \text{ (l/s)}} \right)^{1.80}$$

PD_2 Pressure drop to be determinate (kPa)

PD_1 Pressure drop at nominal condition (kPa)

Q_2 water flow at new working condition (l/s)

Q_1 water flow at nominal condition (l/s)

How to use the formula: Example

The unit EWAD330BZSS has been selected for working at the following conditions:

- Partial heat recovery leaving water temperature 50/55°C

The heating capacity at these working conditions is: 52 kW

The water flow at these working conditions is: 2.48 l/s

The unit EWAD330BZSS at nominal working conditions has the following data:

- Partial heat recovery leaving water temperature 40/45°C

- condenser air inlet: 35°C

The heating capacity at these working conditions is: 86 kW

The water flow at these working conditions is: 4.11 l/s

The pressure drop at these working conditions is: 40 kPa

The pressure drop at the selected working condition will be:

$$PD_2 \text{ (kPa)} = 40 \text{ (kPa)} \times \left(\frac{2.48 \text{ (l/s)}}{4.11 \text{ (l/s)}} \right)^{1.80}$$

$$PD_2 \text{ (kPa)} = 16 \text{ (kPa)}$$

OPT_1-2-3-4-5-6-7_Rev.00_5

5 Options

5 - 1 Options

5

EWAD-BZ

Single Pump (2 poles) - Low Available external static pressure

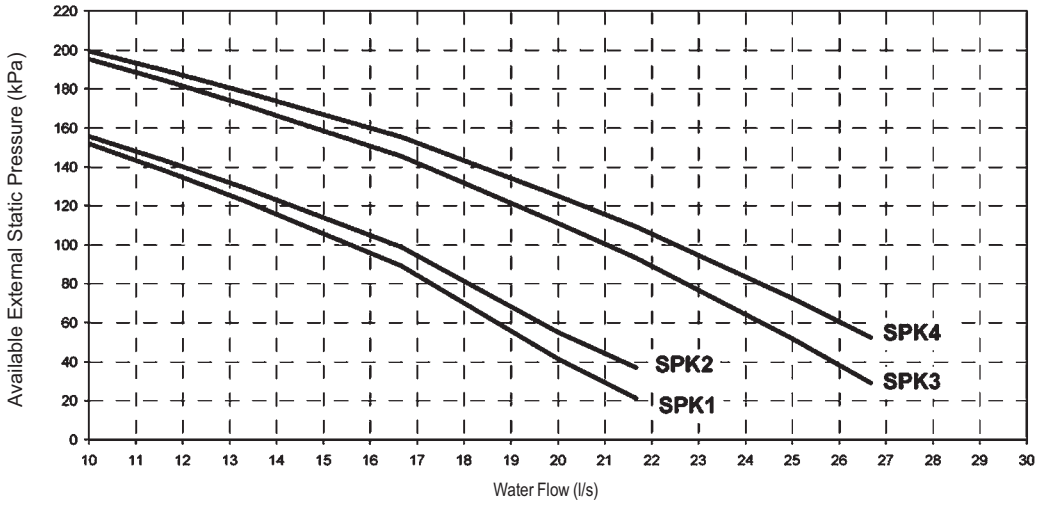

NOTE

When using mixture of water and glycol please contact the factory as above specification can change

Pump Kit	SPK1	SPK2	SPK3	SPK4
Size EWAD-BZSS/SL and Size EWAD-BZXS/XL/XR	330	360	400	420 460
				490 520

Single Pump (2 poles) - High Available external static pressure

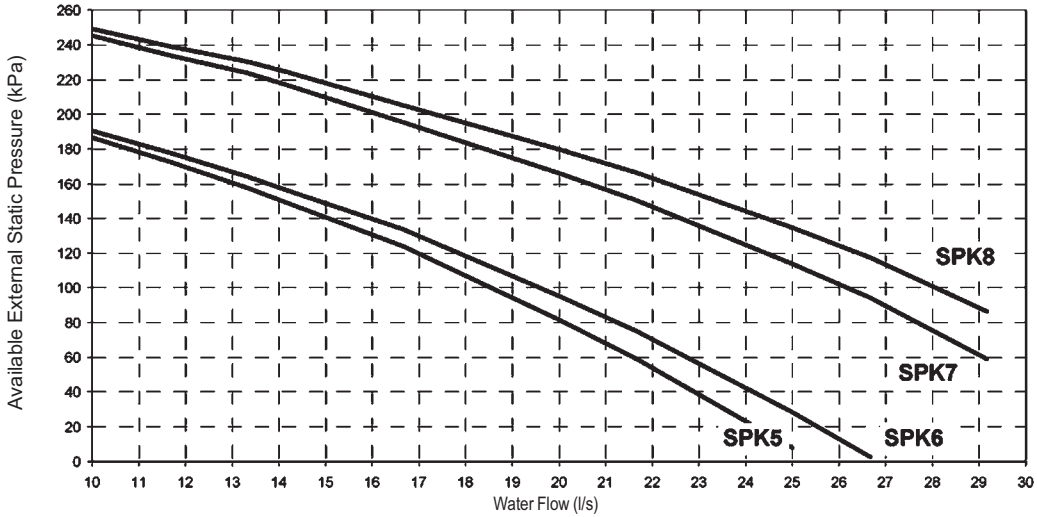

NOTE

When using mixture of water and glycol please contact the factory as above specification can change

Pump Kit	SPK5	SPK6	SPK7	SPK8
Size EWAD-BZSS/SL and Size EWAD-BZXS/XL/XR	330	360	400	420 460
				490 520

5 Options

5 - 1 Options

EWAD-BZ

Twin Pump (2 poles) - Low Available external static pressure

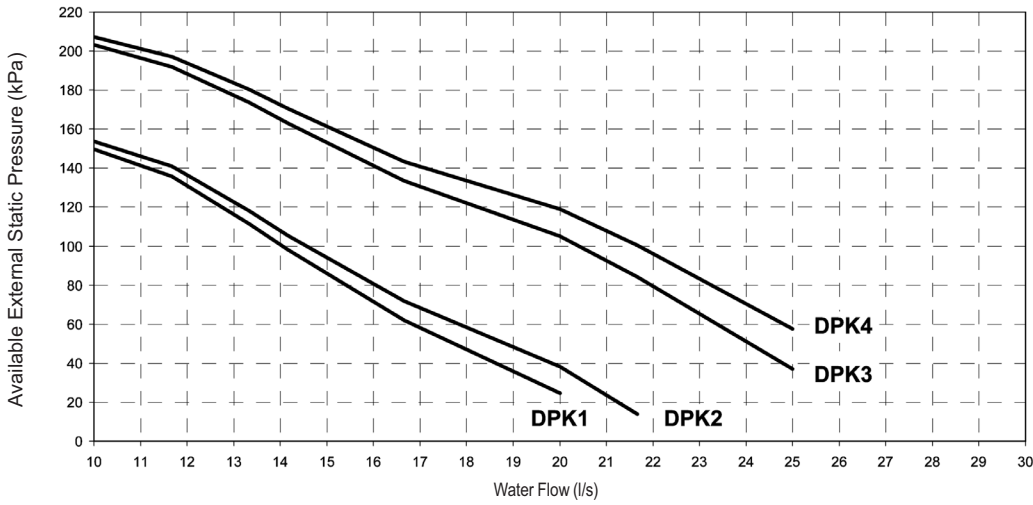

NOTE

when using mixture of water and glycol please contact the factory as above specification can change

Pump Kit	DPK5	DPK6	DPK7	DPK8
Size EWAD-BZSS/SL and Size EWAD-BZXS/XL/XR	330	360	400	420 460 490 520

Twin Pump (2 poles) - High Available external static pressure

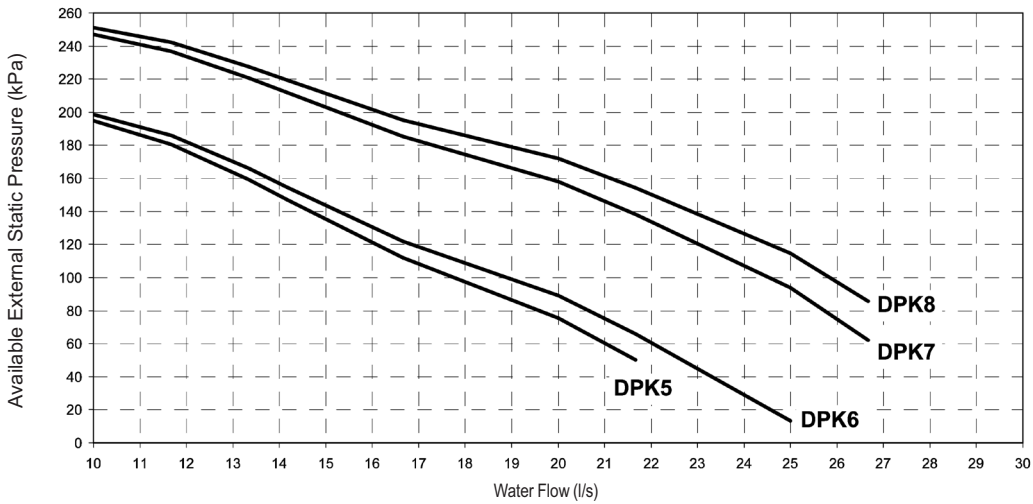

NOTE

when using mixture of water and glycol please contact the factory as above specification can change

Pump Kit	DPK5	DPK6	DPK7	DPK8
Size EWAD-BZSS/SL and Size EWAD-BZXS/XL/XR	330	360	400	420 460 490 520

5 Options

5 - 1 Options

5

EWAD-BZ

Waterpump kit - Technical info

		Pump Motor Power (kW)	Pump Motor Current (A)	Power supply (V-ph-Hz)	PN	Motor Protection	Insulation (Class)	Working Temp. (°C)
Single Pump	SPK 1	4.0	8.0	400V-3ph-50hz	10	IP54	Class F	-10 + 130
	SPK 2	4.0	8.0	400V-3ph-50hz	10	IP54	Class F	-10 + 130
	SPK 3	5.5	10.1	400V-3ph-50hz	10	IP54	Class F	-10 + 130
	SPK 4	5.5	10.1	400V-3ph-50hz	10	IP54	Class F	-10 + 130
	SPK 5	5.5	10.1	400V-3ph-50hz	10	IP54	Class F	-10 + 130
	SPK 6	5.5	10.1	400V-3ph-50hz	10	IP54	Class F	-10 + 130
	SPK 7	7.5	13.7	400V-3ph-50hz	10	IP54	Class F	-10 + 130
	SPK 8	7.5	13.7	400V-3ph-50hz	10	IP54	Class F	-10 + 130
Double Pump	DPK 1	4.0	8.0	400V-3ph-50hz	10	IP54	Class F	-10 + 130
	DPK 2	4.0	8.0	400V-3ph-50hz	10	IP54	Class F	-10 + 130
	DPK 3	5.5	10.1	400V-3ph-50hz	10	IP54	Class F	-10 + 130
	DPK 4	5.5	10.1	400V-3ph-50hz	10	IP54	Class F	-10 + 130
	DPK 5	5.5	10.1	400V-3ph-50hz	10	IP54	Class F	-10 + 130
	DPK 6	5.5	10.1	400V-3ph-50hz	10	IP54	Class F	-10 + 130
	DPK 7	7.5	13.7	400V-3ph-50hz	10	IP54	Class F	-10 + 130
	DPK 8	7.5	13.7	400V-3ph-50hz	10	IP54	Class F	-10 + 130

NOTE

when using mixture of water and glycol please contact the factory as above specification can change

7 Pressure drops

7 - 1 Evaporator Pressure Drops

7

EWAD-BZ

	330	360	400	420	460	490	520
Cooling Capacity (kW)	329	358	395	423	459	488	515
Water Flow (l/s)	15.72	17.10	18.87	20.21	21.93	23.32	24.61
Pressure Drops (kPa)	60	61	72	67	78	69	76

Water flow and pressure drop referred to nominal condition: evaporator water in/out: 12/7°C – condenser air inlet: 35°C

EPD_1-2_Rev.00_1

EWAD-BZ

To determine the pressure drop for different versions or at different working conditions, please refer to the following formula:

$$PD_2 \text{ (kPa)} = PD_1 \text{ (kPa)} \times \left(\frac{Q_2 \text{ (l/s)}}{Q_1 \text{ (l/s)}} \right)^{1.8}$$

where:

- PD₂ Pressure drop to be determinate (kPa)
- PD₁ Pressure drop at nominal condition (kPa)
- Q₂ water flow at new working condition (l/s)
- Q₁ water flow at nominal condition (l/s)

How to use the formula: Example

The unit EWAD330BZSS has been selected for working at the following conditions:

- evaporator water in/out : 11/6°C
- condenser air inlet: 30°C

The cooling capacity at these working conditions is: 336 kW (Rated conditions)

The water flow at these working conditions is: 16.05 l/s (Rated conditions)

The unit EWAD330BZSS at nominal working conditions has the following data:

- evaporator water in/out : 12/7°C
- condenser air inlet: 35°C

The cooling capacity at these working conditions is: 329 kW

The water flow at these working conditions is: 15.72 l/s

The pressure drop at these working conditions is: 60 kPa

The pressure drop at the selected working condition will be:

$$PD_2 \text{ (kPa)} = 60 \text{ (kPa)} \times \left(\frac{16.05 \text{ (l/s)}}{15.72 \text{ (l/s)}} \right)^{1.8}$$

$$PD_2 \text{ (kPa)} = 62 \text{ (kPa)}$$

NOTE - Important

If the calculated evaporator water pressure drop is below 10 kPa or above 100 kPa, please contact the factory for dedicated evaporator.

EPD_1-2_Rev.00_2

8 Centre of gravity

8 - 1 Centre of Gravity

EWAD-BZ

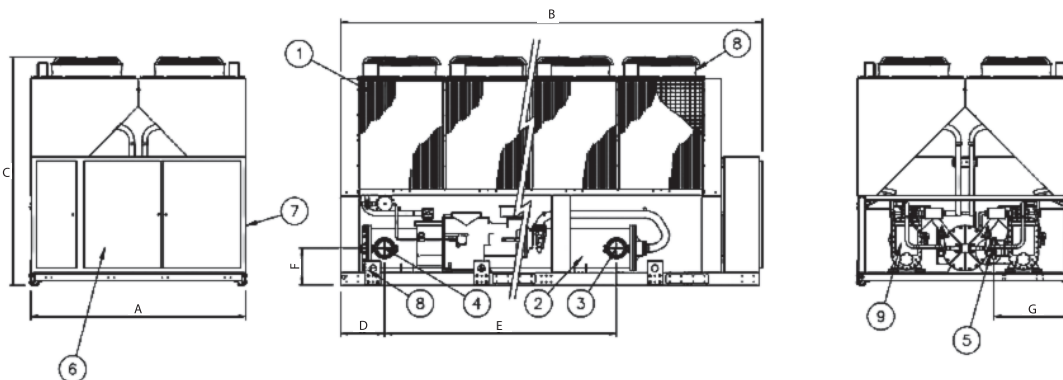

EWAD-BZ	Dimensions							
Size	A	B	C	D	E	F	G	Fans
330	2224	4381	2355	455	2412	379	810	Nr 8
360	2224	4381	2355	455	2412	379	810	Nr 8
400	2224	5281	2355	463	2412	379	810	Nr 10
420	2224	5281	2355	463	2412	379	810	Nr 10
460	2224	6181	2355	463	2412	379	810	Nr 12
490	2224	6181	2355	463	2412	379	810	Nr 12
520	2224	6181	2355	463	2412	379	810	Nr 12

LEGEND

- 1 - Condenser Coil
- 2 - Water heat exchanger (evaporator)
- 3 - Evaporator water inlet
- 4 - Evaporator water outlet
- 5 - Victaulic connection
- 6 - Operating and control panel
- 7 - Slot for power and control connection
- 8 - Fan
- 9 - Compressor

DMN_1b_Rev.02

9 Sound data

9 - 1 Sound Level Data

9

EWAD-BZSS / EWAD-BZXS

Unit size	Sound pressure level at 1 m from the unit in semispheric free field (rif. 2×10^{-5} Pa)									Power
	63 Hz	125 Hz	250 Hz	500 Hz	1000 Hz	2000 Hz	4000 Hz	8000 Hz	dB(A)	dB(A)
330	79.1	77.8	79.0	77.6	80.0	76.1	65.6	56.6	83.0	102.8
360	79.1	77.8	79.0	77.6	80.0	76.1	65.6	56.6	83.0	102.8
400	79.1	77.8	79.0	77.6	80.0	76.1	65.6	56.6	83.0	103.2
420	79.1	77.8	79.0	77.6	80.0	76.1	65.6	56.6	83.0	103.2
460	79.6	78.3	79.5	78.1	80.6	76.6	65.6	56.6	83.5	103.6
490	79.6	78.3	79.5	78.1	80.6	76.6	65.6	56.6	83.5	103.6
520	79.6	78.3	79.5	78.1	80.6	76.6	65.6	56.6	83.5	103.6

EWAD-BZSL / EWAD-BZXL

Unit size	Sound pressure level at 1 m from the unit in semispheric free field (rif. 2×10^{-5} Pa)									Power
	63 Hz	125 Hz	250 Hz	500 Hz	1000 Hz	2000 Hz	4000 Hz	8000 Hz	dB(A)	dB(A)
330	78.4	73.5	73.5	71.8	73.9	69.9	59.6	50.7	77.0	96.9
360	78.4	73.5	73.5	71.8	73.9	69.9	59.6	50.7	77.0	96.9
400	78.4	73.5	73.5	71.8	73.9	69.9	59.6	50.7	77.0	97.3
420	78.4	73.5	73.5	71.8	73.9	69.9	59.6	50.7	77.0	97.3
460	78.4	74.0	74.0	72.3	74.4	70.3	60.1	50.7	77.5	98.2
490	78.4	74.0	74.0	72.3	74.4	70.3	60.1	50.7	77.5	98.2
520	78.4	74.0	74.0	72.3	74.4	70.3	60.1	50.7	77.5	98.2

EWAD-BZXR

Unit size	Sound pressure level at 1 m from the unit in semispheric free field (rif. 2×10^{-5} Pa)									Power
	63 Hz	125 Hz	250 Hz	500 Hz	1000 Hz	2000 Hz	4000 Hz	8000 Hz	dB(A)	dB(A)
330	77.0	70.8	70.0	68.0	69.8	65.6	55.6	46.7	73.0	92.9
360	77.0	70.8	70.0	68.0	69.8	65.6	55.6	46.7	73.0	92.9
400	77.0	70.8	70.0	68.0	69.8	65.6	55.6	46.7	73.0	93.3
420	77.0	70.8	70.0	68.0	69.8	65.6	55.6	46.7	73.0	93.3
460	77.3	71.3	70.5	68.7	70.3	66.1	56.0	46.8	73.5	94.2
490	77.3	71.3	70.5	68.7	70.3	66.1	56.0	46.8	73.5	94.2
520	77.3	71.3	70.5	68.7	70.3	66.1	56.0	46.8	73.5	94.2

NOTES

Note: The values are according to ISO 3744 and are referred to: evaporator 12/7° C, air ambient 35° C, full load operation

9 Sound data

9 - 1 Sound Level Data

EWAD~BZ

Sound Pressure and Sound Power attenuation for different compressor load

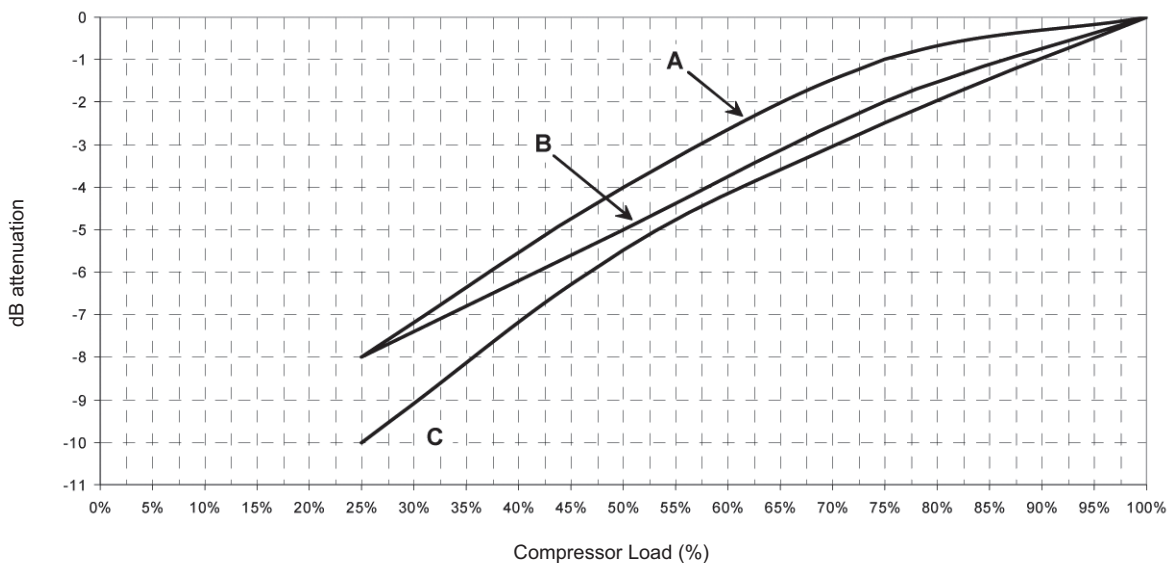

NOTES

Sound pressure in open field conditions on reflecting surface (directivity factor Q=2)

A	EWAD~BZSS / EWAD~BZXS
B	EWAD~BZSL / EWAD~BZXL
C	EWAD~BZXL

9 Sound data

9 - 1 Sound Level Data

Sound pressure level correction factors for different distances

EWAD-BZ

Unit size	Distance					
	1m	5m	10m	15m	20m	25m
330	0.0	-7.7	-12.4	-15.5	-17.7	-19.5
360	0.0	-7.7	-12.4	-15.5	-17.7	-19.5
400	0.0	-7.4	-12.1	-15.1	-17.4	-19.2
420	0.0	-7.4	-12.1	-15.1	-17.4	-19.2
460	0.0	-7.2	-11.8	-14.8	-17.1	-18.8
490	0.0	-7.2	-11.8	-14.8	-17.1	-18.8
520	0.0	-7.2	-11.8	-14.8	-17.1	-18.8

NSL_1-2-3_Rev.00_3

10 Installation

10 - 1 Installation Method

Warning

Installation and maintenance of the unit must be performed only by qualified personnel who have knowledge with local codes and regulations, and experience with this type of equipment. Must be avoided the unit installation in places that could be considered dangerous for all the maintenance operations.

Handling

Care should be taken to avoid rough handling or shock due to dropping the unit. Do not push or pull the unit from anything other than the base frame. Never allow the unit to fall during unloading or moving as this may result in serious damage. To lift the unit, rings are provided in the base frame of the unit. Spreader bar and cables should be arranged to prevent damage to the condenser coil or unit cabinet.

Location

The units are produced for outside installation on roofs, floors or below ground level on condition that the area is free from obstacles for the passage of the condenser air. The unit should be positioned on solid foundations and perfectly level; in the case of installation on roofs or floors, it may be advisable to arrange the use of suitable weight distribution beams. When the units are installed on the ground, a concrete base at least 250 mm wider and longer than the unit's footprint should be laid. Furthermore, this base should withstand the unit weight mentioned in the technical data table.

Space requirements

The units are air-cooled, then it is important to respect the minimum distances which guarantee the best ventilation of the condenser coils. Limitations of space reducing the air flow could cause significant reductions in cooling capacity and an increase in electricity consumption.

To determinate unit placement, careful consideration must be given to assure a sufficient air flow across the condenser heat transfer surface. Two conditions must be avoided to achieve the best performance: warm air recirculation and coil starvation. Both these conditions cause an increase of condensing pressures that result in reductions in unit efficiency and capacity. Moreover the unique microprocessor has the ability to calculate the operating environment of the air cooled chiller and the capacity to optimize its performance staying on-line during abnormal conditions.

Each side of the unit must be accessible after installation for periodic service. Fig.1 shows you minimum recommended clearance requirements.

Vertical condenser air discharge must be unobstructed because the unit would have its capacity and efficiency significantly reduced.

If the units are positioned in places surrounded by walls or obstacles of the same height as the units, the units should be at least 2500 mm from obstacles (fig.3). In the event the obstacles are higher than the units, the units should be at least 3000 mm from the obstacle (fig.2). Units installed closer than the minimum recommended distance to a wall or other vertical riser may experience a combination of coil starvation and warm air recirculation, thus causing reduction in unit capacity and efficiency reductions. The microprocessor control is proactive in response "of design condition". In the case of single or compounded influences restricting airflow to the unit, the microprocessor will act to keep the compressor(s) running (at reduced capacity) rather than allowing a shut-off on high discharge pressure.

When two or more units are positioned side by side it is recommended that the condenser coils are at least 3600 mm distance from one another (fig.4); strong wind could be the cause of air warm recirculation.

For other installation solutions, consult our technicians.

10 Installation

10 - 1 Installation Method

The above recommended information are representative of general installation. A specific evaluation should be done by contractor depending on the case.

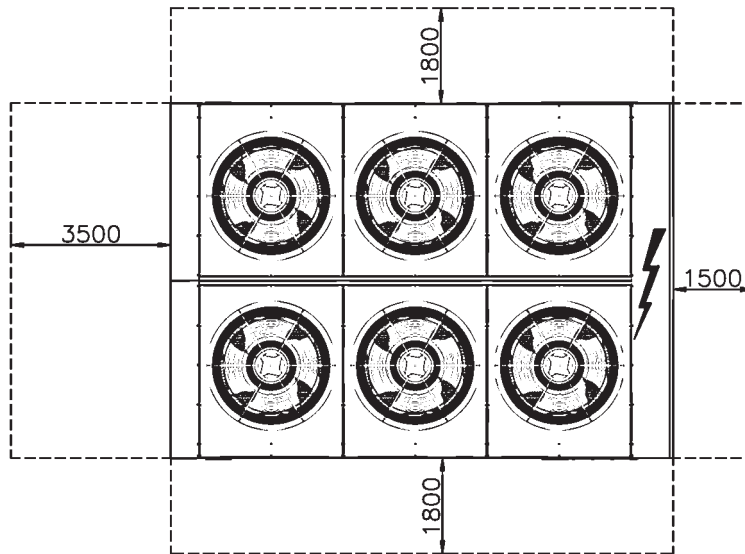

Fig. 1 - Minimum recommended installation clearances

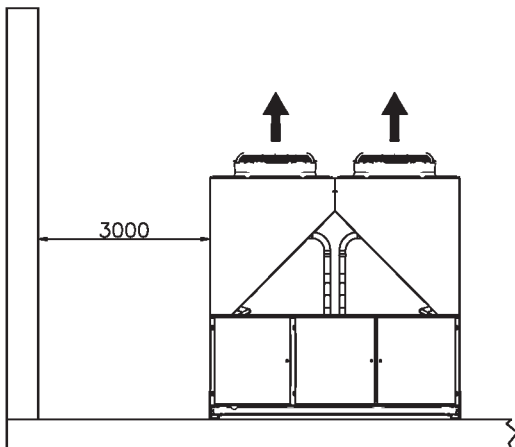

Fig. 2

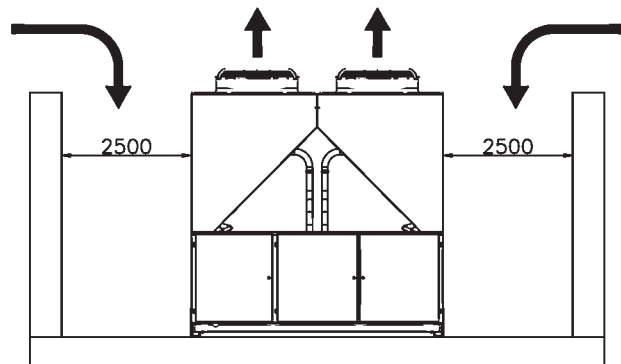

Fig. 3

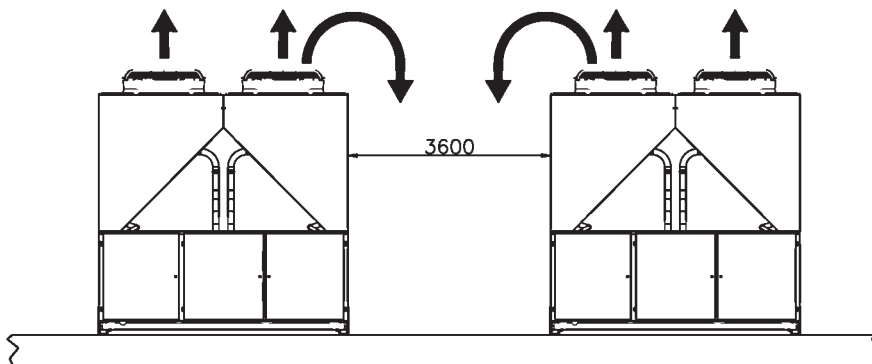

Fig. 4

Minimum clearance requirements for machine maintenance

10 Installation

10 - 1 Installation Method

Acoustic protection

When noise level must meet special requirements, it is necessary to pay the maximum attention to ensure the perfect insulation of the unit from the support base by applying appropriate vibration-dampening devices on the unit, on the water pipes and on the electrical connections.

Storage

The environment conditions have to be in the following limits:

Minimum ambient temperature:	-20°C
Maximum ambient temperature:	+57°C
Maximum R.H.:	95% not condensing

INN_1-2-3_Rev.00_3

11 Operation range

11 - 1 Operation Range

11

Cooling Mode

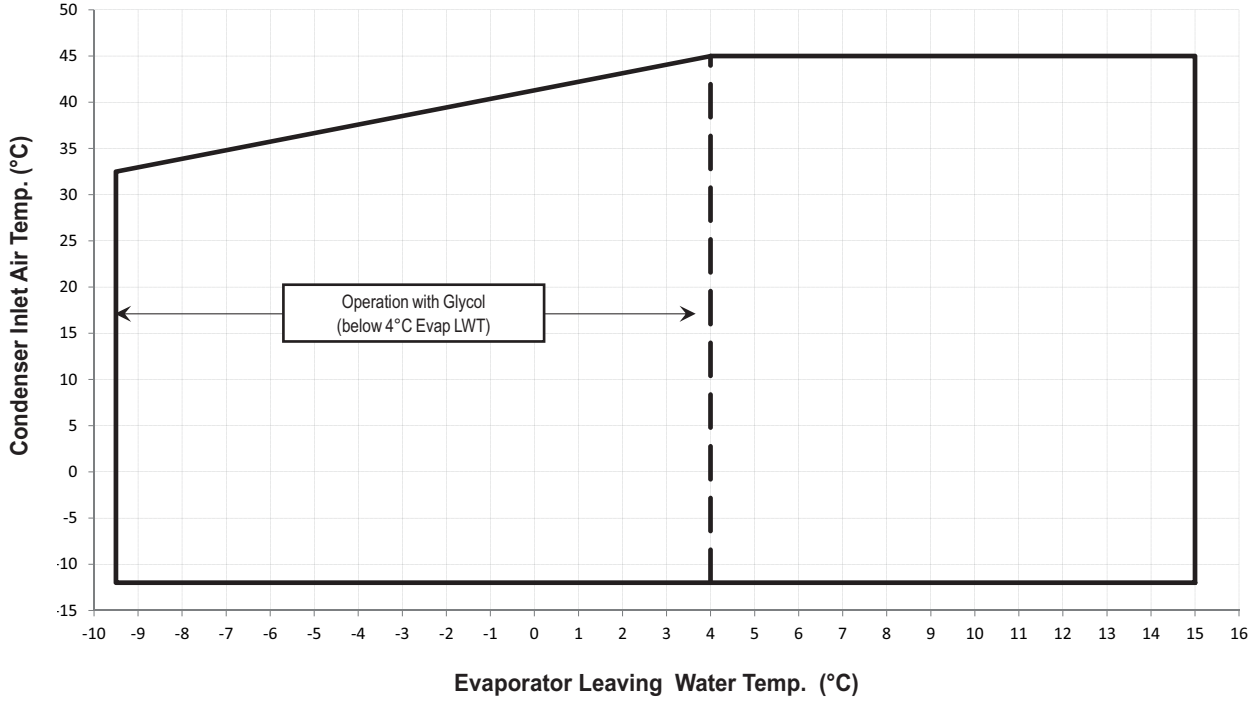

11 Operation range

11 - 1 Operation Range

Table 1: Water heat exchanger - Minimum and maximum water Δt

Max evaporator water Δt	°C	8
Min evaporator water Δt	°C	4

Table 2: Water heat exchanger - Fouling factors

Fouling factors m ² °C / kW	Cooling capacity correction factor	Power input correction factor	EER correction factor
0.0176	1.000	1.000	1.000
0.0440	0.978	0.986	0.992
0.0880	0.957	0.974	0.983
0.1320	0.938	0.962	0.975

Table 3: Air heat exchanger - Altitude correction factors

Elevation above sea level (m)	0	300	600	900	1200	1500	1800
Barometric pressure (mbar)	1013	977	942	908	875	843	812
Cooling capacity correction factor	1.000	0.993	0.986	0.979	0.973	0.967	0.960
Power input correction factor	1.000	1.005	1.009	1.015	1.021	1.026	1.031

Note: Maximum operating altitude is 2000 m above sea level

Note: Contact factory in case the unit has to be installed at altitudes between 1000 and 2000 m above sea level

Table 4.1: Minimum glycol percentage for low water temperature

Evaporator Leaving Water Temperature (°C)	2	0	-2	-4	-6	-8
Ethylene glycol (%)	10	20	20	20	30	30
Propylene glycol (%)	10	20	20	30	30	30

Note: Minimum glycol percentage to be used with evaporator leaving water temperature below 4°C to prevent freezing of water circuit.

Table 4.2: Minimum glycol percentage for low air ambient temperature

Air Ambient Temperature (°C) (2)	-3	-8	-15	-20
Ethylene glycol (%) (1)	10%	20%	30%	40%
Air Ambient Temperature (°C) (2)	-3	-7	-12	-20
Propylene glycol (%) (1)	10%	20%	30%	40%

Note: Minimum glycol percentage to prevent freezing of water circuit at indicated air ambient temperature

Note: Air ambient temperature do exceed the operating limits of the unit, as protection of water circuit may be needed in winter season at non-working conditions.

Table 5: Correction factors for low evaporator leaving water temperature

Evaporator Leaving Water Temperature (°C)	2	0	-2	-4	-6	-8
Cooling Capacity	0.842	0.785	0.725	0.670	0.613	0.562
Compressor Power Input	0.950	0.940	0.920	0.890	0.870	0.840

Note: Correction factors have to be applied at working conditions: evaporator leaving water temperature 7°C

Table 6: Correction factors for water and glycol mixture

	Ethylene Glycol (%)	10%	20%	30%	40%	50%
Ethylene Glycol	Cooling Capacity	0.991	0.982	0.972	0.961	0.946
	Compressor Power Input	0.996	0.992	0.986	0.976	0.966
	Flow Rate (Δt)	1.013	1.04	1.074	1.121	1.178
	Evaporator Pressure Drop	1.070	1.129	1.181	1.263	1.308
Propylene Glycol	Cooling Capacity	0.985	0.964	0.932	0.889	0.846
	Compressor Power Input	0.993	0.983	0.969	0.948	0.929
	Flow Rate (Δt)	1.017	1.032	1.056	1.092	1.139
	Evaporator Pressure Drop	1.120	1.272	1.496	1.792	2.128

11 Operation range

11 - 1 Operation Range

11

How to use the Correction factors proposed in the previous tables

A) Mixture Water and Glycol --- Evaporator leaving water temperature > 4°C

- depending from the type and percentage (%) of glycol filled in the circuit (see table 4.2 and 6)
- multiply the Cooling Capacity, the Compressor Power Input by the Correction factor of Table 6
- starting from this new value of Cooling Capacity, calculate the Flow Rate (l/s) and the Evaporatore Pressure Drop (kPa)
- now multiply the new Flow Rate and the new Evaporator Pressure Drop by the Correction Factors of Table 6

Example:

Unit Size: **EWAD330BZSS**

Mixture: Water
 Working condition: ELWT 12/7°C – Condenser inlet air temperature 35°C
 - Cooling capacity: 329 kW (Rated conditions)
 - Power input: 120 kW (Rated conditions)
 - Flow rate (Δt 5°C): 15.72 l/s
 - Evaporator pressure drop: 60 kPa

Mixture: Water + Ethylene Glycol 30% (for a winter air temperature up to -15°C)
 Working condition: ELWT 12/7°C – Condenser inlet air temperature 35°C
 - Cooling capacity: $329 \times 0.972 = 320$ kW
 - Power input: $120 \times 0.986 = 118$ kW
 - Flow rate (Δt 5°C): 15.30 (referred to 320 kW) $\times 1.074 = 16.43$ l/s
 - Evaporator pressure drop: 65 (referred to 16.43 l/s) $\times 1.181 = 77$ kPa

B) Mixture Water and Glycol --- Evaporator leaving water temperature < 4°C

- depending from the type and percentage (%) of glycol filled in the circuit (see table 4.1 and 4.2 and table 6)
- depending from the evaporator leaving water temperature (see table 5)
- multiply the Cooling Capacity, the Compressor Power Input by the Correction factor of Table 5 and Table 6
- starting from this new value of Cooling Capacity, calculate the Flow Rate (l/s) and the Evaporatore Pressure Drop (kPa)
- now multiply the new Flow Rate and the new Evaporator Pressure Drop by the Correction Factors of Table 6

Example:

Unit Size: **EWAD330BZSS**

Mixture: Water
 Working condition: ELWT 12/7°C – Condenser inlet air temperature 30°C
 - Cooling capacity: 346 kW (Rated conditions)
 - Power input: 109 kW (Rated conditions)
 - Flow rate (Δt 5°C): 16.53 l/s
 - Evaporator pressure drop: 66 kPa

Mixture: Water + Glycol 30% (for a low evaporator leaving temperature of -1/-6°C)
 Working condition: ELWT -1/-6°C – Condenser inlet air temperature 30°C
 - Cooling capacity: $346 \times 0.613 \times 0.972 = 206$ kW
 - Power input: $109 \times 0.870 \times 0.986 = 93.5$ kW
 - Flow rate (Δt 5°C): 9.84 l/s (referred to 206 kW) $\times 1.074 = 10.57$ l/s
 - Evaporator pressure drop: 29 kPa (referred to 10.57 l/s) $\times 1.181 = 34$ kPa

11 Operation range

11 - 1 Operation Range

Items ⁽¹⁾⁽⁶⁾	Cooling Water			Cooled Water		Heated water ⁽²⁾				Tendency if out of criteria		
	Circulating System		Once Flow	Circulating water [Below 20°C]	Supply water ⁽⁴⁾	Low temperature		High temperature				
	Circulating water	Supply water ⁽⁴⁾	Flowing water			Circulating water [20°C ~ 60°C]	Supply water ⁽⁴⁾	Circulating water [60°C ~ 80°C]	Supply water ⁽⁴⁾			
Items to be controlled:	pH	at 25°C	6.5 ~ 8.2	6.0 ~ 8.0	6.0 ~ 8.0	6.0 ~ 8.0	7.0 ~ 8.0	7.0 ~ 8.0	7.0 ~ 8.0	7.0 ~ 8.0	Corrosion + Scale	
	Electrical conductivity	[mS/m] at 25°C	Below 80	Below 30	Below 40	Below 40	Below 30	Below 30	Below 30	Below 30	Corrosion + Scale	
		[µS/cm] at 25°C	(Below 800)	(Below 300)	(Below 400)	(Below 400)	(Below 300)	(Below 300)	(Below 300)	(Below 300)	Corrosion + Scale	
	Chloride ion	[mgCl ⁻ /l]	Below 200	Below 50	Below 50	Below 50	Below 50	Below 50	Below 50	Below 30	Below 30	Corrosion
	Sulfate ion	[mgSO ₄ ²⁻ /l]	Below 200	Below 50	Below 50	Below 50	Below 50	Below 50	Below 50	Below 30	Below 30	Corrosion
	M-alkalinity (pH4.8)	[mgCaCO ₃ /l]	Below 100	Below 50	Below 50	Below 50	Below 50	Below 50	Below 50	Below 50	Below 50	Scale
	Total hardness	[mgCaCO ₃ /l]	Below 200	Below 70	Below 70	Below 70	Below 70	Below 70	Below 70	Below 70	Below 70	Scale
	Calcium hardness	[mgCaCO ₃ /l]	Below 150	Below 50	Below 50	Below 50	Below 50	Below 50	Below 50	Below 50	Below 50	Scale
	Silica ion	[mgSiO ₂ /l]	Below 50	Below 30	Below 30	Below 30	Below 30	Below 30	Below 30	Below 30	Below 30	Scale
	Oxygen	(mg O ₂ /l)	Below 1.0	Below 1.0	Below 1.0	Below 1.0	Below 1.0	Below 1.0	Below 1.0	Below 1.0	Below 1.0	Corrosion
	Particulate size	(mm)	Below 0.5	Below 0.5	Below 0.5	Below 0.5	Below 0.6	Below 0.5	Below 0.6	Below 0.5	Below 0.6	Erosion
	Total dissolved solids	(mg/l)	Below 1000	Below 1000	Below 1000	Below 1000	Below 1001	Below 1000	Below 1001	Below 1000	Below 1001	Erosion
	Ethylene Glycol (weight conc.)		Below 60%	Below 60%	---	Below 60%	Below 60%	Below 60%	Below 60%	Below 60%	Below 60%	--
Items to be referred to	Nitrate ion	(mg NO ₃ ⁻ /l)	Below 100	Below 100	Below 100	Below 100	Below 101	Below 100	Below 101	Below 100	Below 101	Corrosion
	TOC Total organic	(mg/l)	Below 1.0	Below 1.0	Below 1.0	Below 1.0	Below 1.0	Below 1.0	Below 1.0	Below 1.0	Below 1.0	Scale
	Iron	[mgFe/l]	Below 1.0	Below 0.3	Below 1.0	Below 1.0	Below 0.3	Below 1.0	Below 0.3	Below 1.0	Below 0.3	Corrosion + Scale
	Copper	[mgCu/l]	Below 0.3	Below 0.1	Below 1.0	Below 1.0	Below 1.0	Below 1.0	Below 0.1	Below 1.0	Below 0.1	Corrosion
	Sulfite ion	[mgS ₂ ⁻ /l]	Not detectable	Not detectable	Not detectable	Not detectable	Not detectable	Not detectable	Not detectable	Not detectable	Not detectable	Corrosion
	Ammonium ion	[mgNH ₄ ⁺ /l]	Below 1.0	Below 0.1	Below 1.0	Below 1.0	Below 0.1	Below 0.3	Below 0.1	Below 0.1	Below 0.1	Corrosion
	Remaining chloride	[mgCl _r /l]	Below 0.3	Below 0.3	Below 0.3	Below 0.3	Below 0.3	Below 0.25	Below 0.3	Below 0.1	Below 0.3	Corrosion
	Free carbide	[mgCO ₃ /l]	Below 4.0	Below 4.0	Below 4.0	Below 4.0	Below 4.0	Below 4.0	Below 4.0	Below 4.0	Below 4.0	Corrosion
	Stability index		6.0 ~ 7.0	---	---	---	---	---	---	---	---	Corrosion + Scale

- Names, definitions and units are according to JIS K 0101. Units and figures between brackets are old units published as reference only.
- In case of using heated water (more than 40°C), corrosion is generally noticeable. Especially when the iron materials is in direct contact with water without any protection shields, it is desirable to give the valid measure for corrosion. E.g. chemical measure
- In the cooling water using hermetic cooling tower, close circuit water is according to heated water standard, and scattered water is according to cooling water standard.
- Supply water is considered drink water, industrial water and ground water except for genuine water, neutral water and soft water.
- The above mentioned items are representable items in corrosion and scale cases.
- The limits above have to be considered as a general prescription and can not totally assure the absence of corrosion and erosion. Some particular combinations of elements or the presence of components not listed in the table or factors not considered may trigger corrosion phenomena.

OPL_1b-2a-3-4a-5-6_Rev.03_4a

The cooled water distribution circuits should have minimum water content to avoid excessive compressors start and stop. In fact, each time the compressor starts up, an excessive quantity of oil goes from the compressor sump and simultaneously there is a rise in the temperature of the compressor motor's stator due to the inrush current during the start-up. To prevent damage to the compressors, we have envisaged the application of a device to limit frequent stops and restarts.

During the span of one hour there will be no more than 6 starts of the compressor. The plant side should therefore ensure that the overall water content allows a more constant functioning of the unit and consequently greater environmental comfort. The minimum water content per unit should be calculated using this simplified formula:

For 2 compressors unit
M (liters) = (0.1595 x ΔT(°C) + 3.0825) x P(kW)

where:
 M minimum water content per unit expressed in litres
 P Cooling Capacity of the unit expressed in kW
 ΔT evaporator entering / leaving water temperature difference expressed in °C

This formula is valid for:
 - standard microprocessor parameters

For more accurate determination of quantity of water, it is advisable to contact the designer of the plant.

OPL_1b-2a-3-4a-5-6_Rev.03_5

11 Operation range

11 - 1 Operation Range

11

Automatic and Manual Boost --- Cooling Mode

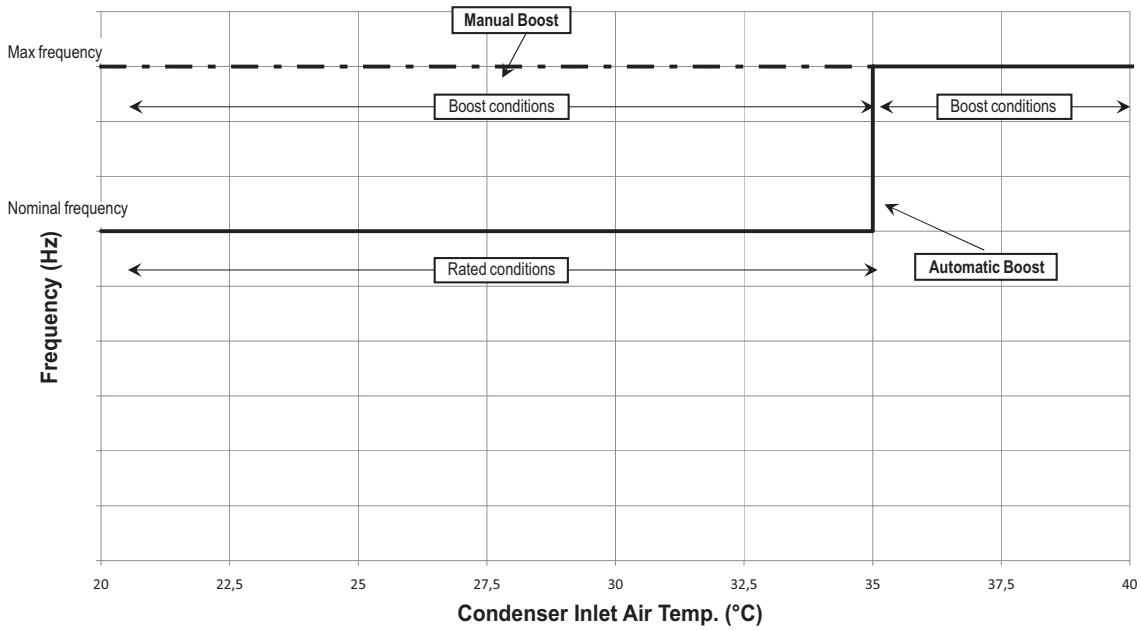

NOTES

1. Automatic boost: unit standard configuration
2. Manual boost: customized configuration by different settings
3. Rated conditions: compressors are working at nominal frequency
4. Boost conditions: compressors are working at the maximum frequency
5. Both automatic and manual boost maximum frequency depends on the maximum current suppliable by the inverter

OPL_1b-2a-3-4a-5-6_Rev.03_6

12 Specification text

12 - 1 Specification Text

Technical Specification for Air Cooled Screw Chiller

GENERAL

The air to Water Heat Pump will be designed and manufactured in accordance with following European directives:

Rating of chillers	EN 12055
Construction of pressure vessel	97/23/EC (PED)
Machinery Directive	98/37/EC as modified
Low Voltage	2006/95/EC
Electromagnetic Compatibility	2004/108/EC
Electrical & Safety codes	EN 60204-1 / EN 60335-2-40
Manufacturing Quality Stds	UNI – EN ISO 9001:2000
Rating of chillers	EN 12055

The unit will be tested at full load in the factory at the nominal working conditions and water temperatures. Before shipment a full test will be held to avoid any losses.

Chiller will be delivered to the job site completely assembled and charged with right refrigerant and oil quantity.

Comply with the manufacturer instructions for rigging and handling equipment.

The unit will be able to start up and operate as standard at full load and outside air temperature from °C to °C with an evaporator leaving fluid temperature between °C and 15 °C

All unit's published performances have to be certified by Eurovent.

REFRIGERANT

Only R-134a will be accepted.

PERFORMANCE

- ✓ Number of air cooled screw chiller:
- ✓ Cooling capacity for single air cooled screw chiller: kW
- ✓ Power input for single air cooled screw chiller in cooling mode: kW
- ✓ Shell & tube heat exchanger entering water temperature in cooling mode: °C
- ✓ Shell & tube heat exchanger leaving water temperature in cooling mode: °C
- ✓ Shell & tube heat exchanger water flow: l/s
- ✓ Nominal outside working ambient temperature in cooling mode: °C

- ✓ The unit should work with electricity in range 400 V ±10%, 3ph, 50Hz without neutral and shall only have one power connection point. The control circuit voltage shall be 24 V maximum, supplied by a factory-installed transformer.

UNIT DESCRIPTION

The unit shall include as standard not less than: two independent refrigerant circuits, semi-hermetic rotary single screw compressors, air-cooled variable electrical frequency driver for each compressor (VFD), electronic expansion device (EEXV), refrigerant direct expansion shell & tube heat exchanger, air-cooled condenser section, R134a refrigerant, lubrication system, motor starting components, suction line shut-off valve, discharge line shut-off valve, control system and all components necessary for safe and stable unit operation.

The unit will be factory assembled on a robust base-frame made of zinc coated steel, protected by an epoxy paint.

12 Specification text

12 - 1 Specification Text

12

NOISE LEVEL AND VIBRATIONS

Sound pressure level at 1 meter distance in free field, semispheric conditions, shall not exceeddB(A). The sound pressure levels must be rated in accordance to ISO 3744.

Other types of rating unacceptable. Vibration level should not exceed 2 mm/s.

DIMENSIONS

Unit dimensions shall not exceed following indications:

- ✓ unit length mm,
- ✓ unit width mm,
- ✓ unit height mm.

HEAT PUMP COMPONENTS

Compressors

- ✓ Semi-hermetic, single-screw type with one main helical rotor meshing with gaterotor. The gaterotor will be constructed of a carbon impregnated engineered composite material. The gaterotor supports will be constructed of cast iron.
- ✓ The oil injection shall be used in order to get high EER (Energy Efficiency Ratio) also at high condensing pressure and low sound pressure levels in each load condition.
- ✓ Refrigerant system differential pressure shall provide oil flow through service replaceable, 0.5 micron, full flow, cartridge type oil filter internal to compressor.
- ✓ Refrigerant system differential pressure shall provide oil injection on all moving compressor parts to correctly lubricate them. Electrical oil pump lubricating system is not acceptable.
- ✓ The compressor's oil cooling must be realized, when necessary, by refrigerant liquid injection. External dedicated heat exchanger and additional piping to carry the oil from the compressor to heat exchanger and viceversa will be not accepted.
- ✓ The compressor shall be provided with an integrated, high efficiency, cyclonic type oil separator and with built-in oil filter, cartridge type.
- ✓ The compressor shall be direct electrical driven, without gear transmission between the screw and the electrical motor.
- ✓ The compressor casing shall be provided with ports to realize economized refrigerant cycles.
- ✓ Shall be present two thermal protection realized by a thermistor for high temperature protection: one temperature sensor to protect electrical motor and another sensor to protect unit and lubricating oil from high discharge gas temperature.
- ✓ The compressor shall be equipped with an electric oil-crankcase heater.
- ✓ Compressor shall be fully field serviceable. Compressor that must be removed and returned to the factory for service shall be unacceptable.

Cooling capacity control system

- ✓ Each unit will have a microprocessor for the control of compressor inverter position and the instantaneous RPM value of the motor.
- ✓ The unit capacity control shall be infinitely modulating, from 100% down to 27% for each compressor (from 100% down to 13.5% of full load for units with 2 compressors).
- ✓ Step unloading unacceptable because of evaporator leaving water temperature fluctuation and low unit efficiency at partial load.
- ✓ The system shall stage the unit based on the leaving evaporator water temperature that shall be controlled by a PID (Proportional Integral Derivative) loop.
- ✓ Unit control logic shall to manage frequency level of the compressor electric motor to exactly match plant load request in order to keep constant the set point for delivered chilled or hot water temperature. In this operating condition unit control logic shall modulate electrical frequency level in a range lower and upper the nominal electrical network value fixed at 50 Hz.

SPC_1-2-3-4-5_Rev.00_2

12 Specification text

12 - 1 Specification Text

- ✓ The microprocessor unit control shall detect conditions that approach protective limits and take self-corrective action prior to an alarm occurring. The system shall automatically reduce chiller capacity when any of the following parameters are outside their normal operating range:
 - o High condenser pressure
 - o Low evaporation refrigerant temperature
 - o High compressor motor amps

Unit-Mounted Variable Frequency Driver (VFD) and Electrical Requirement

- ✓ All interconnecting wiring between the VFD and the chiller shall be factory-installed. Customer electrical connection for compressor motor power shall be limited to main power leads to the single point power connection located into electrical panel.
- ✓ The VFD shall be air cooled type. Water cooled design or refrigerant cooled design are not acceptable.
- ✓ The VFD full load efficiency shall meet or exceed 97% at 100% VFD rated capacity.
- ✓ Base motor frequency shall permit motor to be utilized at nameplate voltage. Adjustable frequency range, monitored by unit's microprocessor control, shall permit a stable unit capacity control down to 13.5% without hot-gas bypass.
- ✓ Starting current for the compressor shall not exceed nominal compressor load amps.
- ✓ Unit power factor shall be not less than 0.95 on entire unit capacity range, from 100% down to 13.5%.

Evaporator

- ✓ The units shall be supplied with shell and tubes counter-flow heat exchanger with single refrigerant pass. It will be refrigerant direct expansion type with refrigerant inside the tubes and water outside (shell side). It will include carbon steel tube sheets, with straight copper tubes internally wound for higher efficiencies, expanded on the tube plates.
- ✓ The external shell shall be linked with an electrical heater to prevent freezing down to -28°C ambient temperature, commanded by a thermostat and shall be insulated with flexible, closed cell polyurethane insulation material (10-mm thick).
- ✓ The evaporator will have 2 circuits, one for each compressor and shall be single refrigerant pass.
- ✓ The water connections shall be VICTAULIC type connections as standard to ensure quick mechanical disconnection between the unit and the hydronic network.
- ✓ Evaporator is manufactured in accordance to PED approval.

Condenser coil

- ✓ The condenser coils are constructed with internally finned seamless copper tubes having a "W" configuration and arranged in a staggered row pattern and mechanically expanded into lanced and rippled aluminium fins with full fin collars for higher efficiencies. The space between the fins are given by a collar that will increase the surface area in connection with the tubes, protecting them from ambient corrosion.
- ✓ The coils will have an integral subcooler circuit that provides sufficient subcooling to effectively eliminate the possibility of liquid flashing and increase the unit's efficiency of 5-7% without increasing in power absorption.
- ✓ The condenser coil shall be leak-tested and submitted to a pressure test with dry air.

Condenser fans

- ✓ The fans used in conjunction with the condenser coils, shall be propeller type with high efficiency design blades to maximize performances and lower noise. The material of the blades is glass reinforced resin and each fan is protected by a guard.
- ✓ The air discharge shall be vertical and each fan must be coupled to the electrical motor. Fan motor will be thermally protected (as standard) by internal thermal motor and protected by circuit breaker installed inside the electrical panel as a standard. The motor will be IP54.

12 Specification text

12 - 1 Specification Text

Refrigerant circuit

- ✓ The unit must have refrigerant circuits completely independent of each other with one compressor and one variable electrical frequency driver per circuit (VFD).
- ✓ Each circuit shall include as standard: electronic expansion device piloted by unit's microprocessor control, compressor discharge shut-off valve, suction line shut-off valve, liquid line shut-off valve with charging connection, replaceable core filter-drier, sight glass with moisture indicator and insulated suction line.

Condensation control

- ✓ The units will be provided with an automatic control for condensing pressure which ensures the working at low external temperatures down to -10 °C, thanks the Inverter on the condenser fans, to maintain condensing pressure.
- ✓ Automatic compressor unloading when abnormal high condensing pressure is detected to prevent the shutdown of the refrigerant circuit (shutdown of the unit) due to a high-pressure fault.

Low Noise unit options (on request)

- ✓ The unit compressors shall be connected with unit's metal baseframe by rubber antivibration supports to prevent the transmission of vibrations to all metal unit structure and so to control the unit noise.
- ✓ The suction lines shall be provided with mufflers to eliminate vibration and so to reduce the noise unit emission.
- ✓ The chiller shall be provided with an acoustically compressor enclosure. This enclosure shall be realized with a light, corrosion resisting aluminium structure and metal panels. The compressors sound-proof enclosure shall be internally fitted with flexible, multi layer, high density materials. The middle layer is 3 mm, very high density and high efficiency noise reduction material. The enclosure shall be carefully assembled to avoid decreasing of its noise reduction power.
- ✓ The chiller shall be provided with very low speed condenser fans and with an improved condenser section.

12 Specification text

12 - 1 Specification Text

Control panel

- ✓ Field power connection, control interlock terminals, and unit control system should be centrally located in an electric panel (IP 54). Power and starting controls should be separate from safety and operating controls in different compartments of the same panel.
- ✓ Starting will be star/delta type.
- ✓ Power and starting controls should include fuses and contactors for each compressor winding and fan motors. Operating and safety controls should include energy saving control; emergency stop switch; overload protection for compressor motor; high and low pressure cut-out switch (for each refrigerant circuit); anti-freeze thermostat; cut-out switch for each compressor.
- ✓ All of the information regarding the unit will be reported on a display and with the internal built-in calendar and clock that will switch the unit ON/OFF during day time all year long.
- ✓ The following features and functions shall be included:
 - resetting chilled water temperature by controlling the return water temperature or by a remote 4-20 mA DC signal or by controlling the external ambient temperature;
 - soft load function to prevent the system from operating at full load during the chilled fluid pulldown period;
 - password protection of critical parameters of control;
 - start-to-start and stop-to-star timers to provide minimum compressor off-time with maximum motor protection;
 - communication capability with a PC or remote monitoring;
 - discharge pressure control through intelligent cycling of condenser fans;
 - lead-lag selection by manual or automatically by circuit run hours;
 - double set point for brine unit version;
 - scheduling via internal time clock to allow programming of a yearly start-stop schedule accommodating weekends and holidays.

Optional High Level Communications Interface

The controller as a minimum shall be capable of providing the data shown in the above list using the following options:

- Option A RS485 Serial card
- Option B RS232 Serial card
- Option C LonWorks interface to FTT10A Transceiver
- Option D Bacnet Compatible



Daikin's unique position as a manufacturer of air conditioning equipment, compressors and refrigerants has led to its close involvement in environmental issues. For several years Daikin has had the intention to become a leader in the provision of products that have limited impact on the environment. This challenge demands the eco design and development of a wide range of products and an energy management system, resulting in energy conservation and a reduction of waste.



Daikin Europe N.V. participates in the Eurovent Certification programme for Air conditioners (AC), Liquid Chilling Packages (LCP) and Fan coil units (FCU). Check on-going validity of certificate online: www.eurovent-certification.com or using: www.certiflash.com

The present leaflet is drawn up by way of information only and does not constitute an offer binding upon Daikin Europe N.V.. Daikin Europe N.V. has compiled the content of this leaflet to the best of its knowledge. No express or implied warranty is given for the completeness, accuracy, reliability or fitness for particular purpose of its content and the products and services presented therein. Specifications are subject to change without prior notice. Daikin Europe N.V. explicitly rejects any liability for any direct or indirect damage, in the broadest sense, arising from or related to the use and/or interpretation of this leaflet. All content is copyrighted by Daikin Europe N.V.

BARCODE

Daikin products are distributed by: