



Applied Systems Technical Data

Water cooled chiller, high efficiency



EEDEN13-424

EWWD-I-XS

TABLE OF CONTENTS

EWWD-I-XS

1	Features	2
2	Specifications	3
	Technical Specifications	3
	Technical Specifications	4
	Electrical Specifications	5
	Electrical Specifications	5
3	Features and advantages	7
	Features and Advantages	7
4	General Characteristics	9
	General characteristics	9
5	Nomenclature	14
	Nomenclature	14
6	Capacity tables	15
	Cooling/Heating Capacity Tables	15
	Partial Heat Recovery Capacity tables	19
7	Dimensional drawings	20
	Dimensional Drawings	20
8	Sound data	21
	Sound Level Data	21
9	Installation	23
	Installation Method	23
10	Operation range	24
	Operation Range	24
11	Hydraulic performance	29
	Water Pressure Drop Curve Evaporator/Condenser	29
	Partial Heat Recovery Pressure Drop	30
	Total Heat Recovery Pressure Drop	31
12	Specification text	32
	Specification Text	32

1 Features

- High efficiency, standard sound levels
- All models are PED pressure vessel approved
- Stepless single-screw compressor
- Optimised for use with R-134a
- 1 or 2 truly independent refrigerant circuits
- Standard electronic expansion valve
- DX shell and tube evaporator – one pass refrigerant side to minimize pressure drops
- MicroTech III controller

1



2

2 Specifications

2-1 Technical Specifications					EWWD360I-XS	EWWD440I-XS	EWWD500I-XS	EWWD600I-XS	EWWD750I-XS	EWWD800I-XS
Cooling capacity	Nom.		kW	360 (1)	431 (1)	504 (1)	570 (1)	717 (1)	791 (1)	
Heating capacity	Nom.		kW	435 (2)	520 (2)	608 (2)	697 (2)	865 (2)	955 (2)	
Capacity control	Method		Stepless							
	Minimum capacity		%	25				13		
Power input	Cooling	Nom.	kW	74.5 (1)	89.5 (1)	104.5 (1)	126.8 (1)	147.9 (1)	163.4 (1)	
	Heating	Nom.	kW	74.5 (2)	89.5 (2)	104 (2)	127 (2)	148 (2)	163 (2)	
EER				4.83 (1)	4.82 (1)		4.50 (1)	4.85 (1)	4.84 (1)	
ESEER				4.75	4.72	4.71	4.52	5.40	5.50	
COP				5.83 (2)	5.82 (2)		5.50 (2)	5.85 (2)	5.84 (2)	
IPLV				5.72	5.63	5.57	5.47	6.45	6.89	
Casing	Colour		Ivory white							
	Material		Galvanized and painted steel sheet							
Dimensions	Unit	Height	mm	1,883				2,245		
		Width	mm	1,430				1,350		
		Depth	mm	4,012				4,782		
Weight	Unit		kg	2,594	2,667	2,704		4,964	4,997	
	Operation weight		kg	2,998	3,078	3,116		5,582	5,615	
Water heat exchanger - evaporator	Type		Single pass shell and tube							
	Water volume		l	326	317	308		539		
	Water flow rate	Nom.	l/s	17.3	20.7	24.1	27.3	34.4	37.9	
	Nominal water pressure drop	Cooling	Heat exchanger	kPa	64		54	68	58	68
		Insulation material		Closed cell						
Water heat exchanger - condenser	Type		Single pass shell and tube							
	Water flow rate	Nom.	l/s	20.9	25.0	29.2	33.4	20.8	21.0	
	Nominal water pressure drop	Cooling	kPa	48	47	51	66	48		
	Nominal water pressure drop 2	Cooling	kPa	-				48	47	
	Model	Quantity		1				2		
Sound power level	Cooling	Nom.	dBA	94	97					
Sound pressure level	Cooling	Nom.	dBA	75 (3)	76 (3)	78 (3)				
Compressor	Type		Semi-hermetic single screw compressor							
	Quantity		1				2			
	Oil	Charged volume		l	16				32	
Operation range	Evaporator	Cooling	Min.	°CDB	-8					
			Max.	°CDB	15					
	Condenser	Cooling	Min.	°CDB	20					
			Max.	°CDB	55					
Refrigerant	Type		R-134a							
	Circuits	Quantity		1				2		
Refrigerant circuit	Charge		kg	90	87	85		180	177	
Piping connections	Evaporator water inlet/outlet (OD)			168.3mm				219.1mm		
	Condenser water inlet/outlet (OD)			5"						
Safety devices	Item	01	High discharge pressure (pressure switch)							
		02	High discharge pressure (pressure transducer)							
		03	Low suction pressure (pressure transducer)							
		04	Compressor motor protection							
		05	High discharge temperature							
		06	Low oil pressure							
		07	Low pressure ratio							
		08	High oil filter pressure drop							
		09	Phase monitor							
		10	Emergency stop							
		11	Water freeze protection controller							

2 Specifications

2-2 Technical Specifications					EWWDC850I-XS	EWWDC950I-XS	EWWDC10I-XS	EWWDC11I-XS	EWWDC12I-XS
Cooling capacity	Nom.		kW	863 (1)	929 (1)	971 (1)	1,035 (1)	1,130 (1)	
Heating capacity	Nom.		kW	1,040 (2)	1,122 (2)	1,180 (2)	1,263 (2)	1,380 (2)	
Capacity control	Method			Stepless					
	Minimum capacity			13					
Power input	Cooling	Nom.	kW	177.8 (1)	193.1 (1)	208.4 (1)	228.3 (1)	250 (1)	
	Heating	Nom.	kW	178 (2)	193 (2)	208 (2)	228 (2)	250 (2)	
EER				4.85 (1)	4.81 (1)	4.66 (1)	4.53 (1)	4.51 (1)	
ESEER				5.35	5.40	5.18	5.37	5.02	
COP				5.85 (2)	5.81 (2)	5.66 (2)	5.53 (2)	5.51 (2)	
IPLV				6.33	6.63	6.19	6.35	5.97	
Casing	Colour			Ivory white					
	Material			Galvanized and painted steel sheet					
Dimensions	Unit	Height	mm	2,245					
		Width	mm	1,350					
		Depth	mm	4,782					
Weight	Unit		kg	5,049	5,073	5,097	5,132		
	Operation weight		kg	5,671	5,695	5,729	5,741		
Water heat exchanger - evaporator	Type			Single pass shell and tube					
	Water volume			528		504			
	Water flow rate	Nom.	l/s	41.3	44.5	46.6	49.5	54.1	
	Nominal water pressure drop	Cooling	Heat exchanger	kPa	56	64	72	46	52
		Insulation material			Closed cell				
Water heat exchanger - condenser	Type			Single pass shell and tube					
	Water flow rate	Nom.	l/s	25.0		28.3		33.1	
	Nominal water pressure drop	Cooling	kPa	47		50	51	65	
		Cooling	kPa	47	50		65		
	Model	Quantity			2				
Sound power level	Cooling	Nom.	dBA	98	99	100			
Sound pressure level	Cooling	Nom.	dBA	79 (3)	80 (3)	81 (3)			
Compressor	Type			Semi-hermetic single screw compressor					
	Quantity			2					
	Oil	Charged volume		32					
Operation range	Evaporator	Cooling	Min.	°CDB	-8				
			Max.	°CDB	15				
	Condenser	Cooling	Min.	°CDB	20				
			Max.	°CDB	55				
Refrigerant	Type			R-134a					
	Circuits	Quantity			2				
Refrigerant circuit	Charge		kg	174	172	170			
Piping connections	Evaporator water inlet/outlet (OD)			219.1mm					
	Condenser water inlet/outlet (OD)			5"					
Safety devices	Item	01	High discharge pressure (pressure switch)						
		02	High discharge pressure (pressure transducer)						
		03	Low suction pressure (pressure transducer)						
		04	Compressor motor protection						
		05	High discharge temperature						
		06	Low oil pressure						
		07	Low pressure ratio						
		08	High oil pressure drop	High oil filter pressure drop			High oil pressure drop		
		09	Phase monitor						
		10	Emergency stop						
		11	Water freeze protection controller						

2 Specifications

2-3 Electrical Specifications			EWWD360I-XS	EWWD440I-XS	EWWD500I-XS	EWWD600I-XS	EWWD750I-XS	EWWD800I-XS	
Compressor	Phase		3~						
	Voltage		V		400				
	Voltage range	Min.	%		-10				
		Max.	%		10				
	Maximum running current		A	204	233	271	299	204	
Starting method		Wye-delta							
Compressor 2	Maximum running current		A	-			204	233	
Power supply	Phase		3~						
	Frequency		Hz		50				
	Voltage		V		400				
	Voltage range	Min.	%		-10				
		Max.	%		10				
Unit	Maximum starting current		A	330	464		493	627	
	Nominal running current (RLA)	Cooling	A	117	144	164	194	235	261
		Maximum running current		A	204	233	271	299	407
	Max unit current for wires sizing		A	224	256	298	328	448	480

Notes

- (1) Cooling: entering evaporator water temp. 12°C; leaving evaporator water temp. 7°C; entering condenser water temp. 30°C; leaving condenser water temp. 35°C; full load operation.
- (2) Heating capacity, unit power input and COP are based on the following conditions: evaporator 15/10°C; condenser 40/45°C, unit at full load operation
- (3) Sound level data are measured at entering evaporator water temp. 12°C; leaving evaporator water temp. 7°C; entering condenser water temp. 30°C; leaving condenser water temp. 35°C; full load operation; standard: ISO3744
- (4) Allowed voltage tolerance $\pm 10\%$. Voltage unbalance between phases must be within $\pm 3\%$.
- (5) Maximum starting current: starting current of biggest compressor + current of the other compressor at 75 % of maximum load
- (6) Nominal current in cooling mode: entering evaporator water temp. 12°C; leaving evaporator water temp. 7°C; entering condenser water temp. 30°C; leaving condenser water temp. 35°C; compressors.
- (7) Maximum running current is based on max compressor absorbed current in its envelope
- (8) Maximum unit current for wires sizing is based on minimum allowed voltage.
- (9) Maximum current for wires sizing: compressor full load ampere x 1.1

2 Specifications

2

2-4 Electrical Specifications				EWWD850I-XS	EWWD950I-XS	EWWD10I-XS	EWWD11I-XS	EWWD12I-XS	
Compressor	Phase			3~					
	Voltage			V					
	Voltage range	Min.	%	-10					
		Max.	%	10					
	Maximum running current			A	233	271		299	
Starting method			Wye-delta						
Compressor 2	Maximum running current			A	233	271		299	
Power supply	Phase			3~					
	Frequency			Hz					
	Voltage			V					
	Voltage range	Min.	%	-10					
		Max.	%	10					
Unit	Maximum starting current			A	650	681		703	
	Nominal running current (RLA)	Cooling		A	287	307	327	358	388
		Maximum running current			A	465	504	542	570
	Max unit current for wires sizing			A	512	554	597	627	657

Notes

- (1) Cooling: entering evaporator water temp. 12°C; leaving evaporator water temp. 7°C; entering condenser water temp. 30°C; leaving condenser water temp. 35°C; full load operation.
- (2) Heating capacity, unit power input and COP are based on the following conditions: evaporator 15/10°C; condenser 40/45°C, unit at full load operation
- (3) Sound level data are measured at entering evaporator water temp. 12°C; leaving evaporator water temp. 7°C; entering condenser water temp. 30°C; leaving condenser water temp. 35°C; full load operation; standard: ISO3744
- (4) Allowed voltage tolerance $\pm 10\%$. Voltage unbalance between phases must be within $\pm 3\%$.
- (5) Maximum starting current: starting current of biggest compressor + current of the other compressor at 75 % of maximum load
- (6) Nominal current in cooling mode: entering evaporator water temp. 12°C; leaving evaporator water temp. 7°C; entering condenser water temp. 30°C; leaving condenser water temp. 35°C; compressors.
- (7) Maximum running current is based on max compressor absorbed current in its envelope
- (8) Maximum unit current for wires sizing is based on minimum allowed voltage.
- (9) Maximum current for wires sizing: compressor full load ampere x 1.1

3 Features and advantages

3 - 1 Features and Advantages

Features and advantages

The EWWD~I- water cooled chillers, featuring 1, 2 or 3 single screw compressors, are manufactured to satisfy the requirements of the consultants and the end user. Units are designed to minimise energy costs while maximising the refrigeration capacities. Daikin's chiller design experience, combined with outstanding features makes the EWWD~I- chiller unmatched in the industry.

Seasonal quietness

The compressor design with a single screw and twin rotors allows a constant gas flow. This compression process completely eliminates gas pulsations. The oil injection also results in significant mechanical noise reduction.

The twin gas compressor discharge chambers are designed to act as attenuators, based on the harmonic wave principle with destructive interference, thus always resulting equal to zero. The extremely low noise compressor performance affords the use of EWWD~I- chiller for all applications.

The reduced number of vibrations produced from the EWWD~I- chiller offers a surprisingly quiet operation eliminating the noise transmission through the structure and the chilled water piping system.

Infinitely capacity control

Cooling capacity control is infinitely variable by means of a screw compressor controlled by microprocessor system. Each unit has infinitely variable capacity control from 100% down to 25% (one compressor unit), down to 12,5% (two compressors units) and down to 8.3% (three compressors units). This modulation allows the compressor capacity to exactly match the building cooling load without any leaving evaporator water temperature fluctuation. This chilled water temperature fluctuation is avoided only with a stepless control.

With a compressor load step control in fact, the compressor capacity, at partial loads, will be too high or too low compared to the building cooling load. The result is an increase in chiller energy costs, particularly at the part-load conditions at which the chiller operates most of the time.

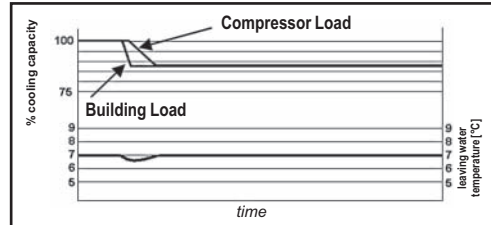

ELWT fluctuation with stepless capacity control

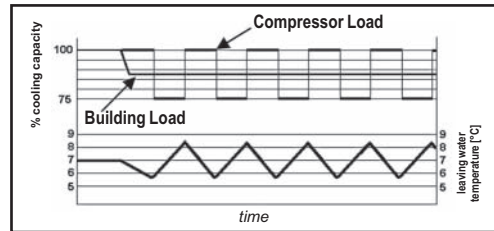

ELWT fluctuation with steps capacity control (4 steps)

Units with stepless regulation offer benefits that the units with step regulation are unable to match. The ability to follow the system energy demand at any time and the possibility to provide steady outlet water temperature without deviations from the set-point, are the two points that allow you to understand how the optimum operating conditions of a system can be met only through the use of a unit with stepless regulation.

Code requirements – Safety and observant of laws/directives

All water cooled units are designed and manufactured in accordance with applicable selections of the following:

Construction of pressure vessel	97/23/EC (PED)
Machinery Directive	2006/42/EC
Low Voltage	2006/95/EC
Electromagnetic Compatibility	2004/108/EC
Electrical & Safety codes	EN 60204-1 / EN 60335-2-40
Manufacturing Quality Stds	UNI – EN ISO 9001:2004

3 Features and advantages

3 - 1 Features and Advantages

3

Certifications

All units manufactured are CE marked, complying with European directives in force, concerning manufacturing and safety. On request units can be produced complying with laws in force in non European countries (ASME, GOST, etc.), and with other applications, such as naval (RINA, etc.).

Versions

EWWD~I- is available in two different Efficiency Versions:

S: Standard Efficiency

18 sizes, covering a cooling capacity range from 333 up to 1510 kW, EER up to 4.66 and ESEER up to 5.75.

X: High Efficiency

11 sizes, covering a cooling capacity range from 362 up to 1134 kW, EER up to 5.10 and ESEER up to 6.31.

The EER (Energy Efficiency Ratio) is the ratio of the Cooling Capacity to the Power Input of the unit. The Power Input includes: the power input for operation of the compressor, the power input of all control and safety devices.

The ESEER (European Seasonal Energy Efficiency Ratio) is a weighed formula enabling to take into account the variation of EER with the load rate and the variation of water inlet condenser temperature.

$$ESEER = A \times EER_{100\%} + B \times EER_{75\%} + C \times EER_{50\%} + D \times EER_{25\%}$$

	A	B	C	D
Coefficient	0.03 (3%)	0.33 (33%)	0.41 (41%)	0.23 (23%)
Condenser water inlet temperature (°C)	30	26	22	18

Sound Configuration

EWWD~I- is available in standard sound level configuration:

S: Standard Noise

4 General Characteristics

4 - 1 General characteristics

General characteristics

Cabinet and structure

The cabinet is made of galvanized steel sheet and painted to provide a high resistance to corrosion. Colour Ivory White (Munsell code 5Y7.5/1) (\pm RAL7044). The base frame has eye-hook for lifting the unit with ropes for an easy installation. The weight is uniformly distributed along the profiles of the base and this facilitates the arrangement of the unit.

Screw compressors

The single-screw compressor has a well balanced compression mechanism which cancels the screw rotor load in both the radial and axial directions. Inherent to the basic single-screw compressor design is the virtually load-free operation that gives main bearing design life of 3-4 times greater than twin-screws, and eliminates expensive and complicated thrust balancing schemes. The two exactly opposed gate rotors create two exactly opposed compression cycles. Compression is made at the lower and upper parts of the screw rotor at the same time, thus cancelling the radial loads. Also, both ends of the screw rotor are subjected to suction pressure only, which cancels the axial loads and eliminates the huge thrust loads inherent in twin-screw compressors.

Oil injection is used for these compressors in order to get EER at high condensing pressure. EWWD~I- units are provided with a high efficiency oil separator to maximise oil extraction.

Compressors have an infinitely variable capacity control down to 25% of its total capacity. This control is made by means of capacity slides controlled by microprocessors.

Standard start is star-delta type; soft start type is available as option.

Ecological R-134a refrigerant

The compressors have been designed to operate with R-134a, ecological refrigerant with zero ODP (Ozone Depletion Potential) and very low GWP (Global Warming Potential) that means low TEWI (Total Equivalent Warming Impact).

Evaporator

The units are equipped with a Direct Expansion shell&tube evaporator with copper tubes rolled into steel tubesheets. The evaporators are single-pass on both the refrigerant and water sides for pure counter-flow heat exchange and low refrigerant pressure drops. Both attributes contribute to the heat exchanger effectiveness and total unit's outstanding efficiency.

The external shell is covered with a 10mm closed cell insulation material. Each evaporator has 1 circuit for each compressor and is manufactured in accordance to PED approval. The evaporator water outlet connections are provided with Victaulic Kit (as standard).

Condensers

The units are equipped with Direct Expansion shell&tube condensers, with copper tubes rolled into steel tubesheets. The unit has independent condensers, one per circuit. is manufactured in accordance to PED approval. Condensers are provided with liquid shut-off valve and spring loaded relief valve.

On the standard efficiency units, condensers are provided in 1 pass configuration as standard and 2 pass configuration is available as option; on the high efficiency units 2 pass configuration is provided as standard and 4 pass configuration is available as option.

With 2-4 pass condensers the option heat recovery is not available.

Electronic expansion valve

The unit is equipped with the most advanced electronic expansion valves to achieve precise control of refrigerant mass flow. As today's system requires improved energy efficiency, tighter temperature control, wider range of operating conditions and incorporate features like remote monitoring and diagnostics, the application of electronic expansion valves becomes mandatory. Electronic expansion valve proposes features that make it unique: short opening and closing time, high resolution, positive shut-off function to eliminate use of additional solenoid valve, highly linear flow capacity, continuous modulation of mass flow without stress in the refrigerant circuit and corrosion resistance stainless steel body.

EEXV strength point is the capacity to work with lower ΔP between high and low pressure side, than a thermostatic expansion valve. The electronic expansion valve allows the system to work with low condenser pressure (winter time) without any refrigerant flow problems and with a perfect chilled water leaving temperature control.

GNC_1a-2-3-4b-5a_Rev.03_1a

4 General Characteristics

4 - 1 General characteristics

4

Refrigerant Circuit

Each unit has independent refrigerant circuits and each one includes:

- Single screw compressor with external cyclonic oil separator
- (Common) Evaporator
- Condenser
- Oil pressure transducer
- High pressure switches
- High pressure transducer
- Low pressure transducer
- Moisture liquid indicator
- High efficiency oil separator
- Replaceable core filter-drier
- Electronic expansion valve

Electrical control panel

Power and control are located in the main panel that is manufactured to ensure protection against all weather conditions. The electrical panel is IP54 and (when opening the doors) internally protected with Plexiglas panel against possible accidental contact with electrical components (IP20). The main panel is fitted with a main switch interlocked door.

Power Section

The power section includes compressors fuses and control circuit transformer.

MicroTech III controller

MicroTech III controller is installed as standard; it can be used to modify unit set-points and check control parameters. A built-in display shows chiller operating status plus temperatures and pressures of water, refrigerant, programmable values, set-points. A sophisticated software with predictive logic, selects the most energy efficient combination of compressors and EEXV to keep stable operating conditions to maximise chiller energy efficiency and reliability.

MicroTech III is able to protect critical components based on external signs from its system (such as motor temperatures, refrigerant gas and oil pressures, correct phase sequence, pressure switches and evaporator). The input coming from the high pressure switch cuts all digital output from the controller in less than 50ms, this is an additional security for the equipment.

Fast program cycle (200ms) for a precise monitoring of the system. Floating point calculations supported for increased accuracy in P/T conversions.

Control section - main features

- Management of the compressor stepless capacity.
- Chiller enabled to work in partial failure condition.
- Full routine operation at condition of:
 - high ambient temperature value
 - high thermal load
 - high evaporator entering water temperature (start-up)
- Display of evaporator entering/leaving water temperatures.
- Display of condensing-evaporating temperatures and pressures, suction and discharge superheat for each circuit.
- Leaving water evaporator temperature regulation. Temperature tolerance = 0.1°C.
- Compressor and evaporator pumps hour counters.
- Display of Status Safety Devices.
- Number of starts and compressor working hours.
- Optimized management of compressor load.
- Re-start in case of power failure (automatic / manual).
- Soft Load (optimized management of the compressor load during the start-up).
- Start at high evaporator water temperature.

GNC_1a-2-3-4b-5a_Rev.03_2

4 General Characteristics

4 - 1 General characteristics

- Return Reset (Set Point Reset based on return water temperature).
- Set point Reset (optional).
- Application and system upgrade with commercial SD cards.
- Ethernet port for remote or local servicing using standard web browsers.
- Two different sets of default parameters could be stored for easy restore.

Safety device / logic for each refrigerant circuit

- High pressure (pressure switch).
- High pressure (transducer).
- Low pressure (transducer).
- High compressor discharge temperature.
- High motor winding temperature.
- Phase Monitor.
- Low pressure ratio.
- High oil pressure drop
- Low oil pressure.
- No pressure change at start.

System security

- Phase monitor.
- Low Ambient temperature lock-out.
- Freeze protection.

Regulation type

Proportional + integral + derivative regulation on the evaporator leaving water output probe.

MicroTech III

MicroTech III built-in terminal has the following features.

- 164x44 dots liquid crystal display with white back lighting. Supports Unicode fonts for multi-lingual.
- Key-pad consisting of 3 keys.
- Push'n'Roll control for an increased usability.
- Memory to protect the data.
- General faults alarm relays.
- Password access to modify the setting.
- Application security to prevent application tampering or hardware usability with third party applications.
- Service report displaying all running hours and general conditions.
- Alarm history memory to allow an easy fault analysis.

Supervising systems (on request)

MicroTech III remote control

MicroTech III is able to communicate to BMS (Building Management System) based on the most common protocols as:

- ModbusRTU
- LonWorks, now also based on the international 8040 Standard Chiller Profile and LonMark Technology
- BacNet BTP certified over IP and MS/TP (class 4) (Native)

4 General Characteristics

4 - 1 General characteristics

4

Chiller Sequencing

MicroTech III controller allows an easy plug-in sequencing technology based on digital or serial panel.

Digital Sequencing Panel

This panel is basically a step inserter that switches ON/OFF up to 11 units (chillers or heat pumps operating in the same cooling/heating mode) depending on the selected set point; the units are connected with the panel through standard cables and no serial card is requested.

Serial Sequencing Panel

Basically this panel sequences a chiller plant by switching on/off the units (up to 7 chillers) taking into account their running hours and the requested plant load, in order to optimise the number of working units for each condition; serial cards and shielded cables are requested to connect the panel with the units and, if installed, a BMS.

Standard accessories (supplied on basic unit)

Evaporator Victaulic Kit - Hydraulic joint with gasket for an easy and quick water connection.

Evaporator Water side design pressure 10 bar

Condenser Water side design pressure 16 bar

Condenser 1 pass (DT 4-8°C) on standard efficiency units, 2 passes (DT 4-8°C) on high efficiency units

Y-D starter - Star Delta starter is the standard type.

Double set-point - Dual leaving water temperature set-points.

Phase monitor - The phase monitor controls that phases sequence is correct and controls phase loss.

High Pressure Side Manometers

Hour Run meter - Digital compressors hour run meter.

General fault contactor - Contactor for alarm warning.

Set-point reset, demand limit and alarm from external device – The leaving water temperature set-point can be overwritten with the following options: 4-20mA from external source (by user); outside ambient temperature; evaporator water temperature Δt . Moreover the device allow the user to limit the load of the unit by 4-20mA signal or by network system and the microprocessor is able to receive an alarm signal from an external device (pump etc... - user can decide if this alarm signal will stop or not the unit).

Electronic Expansion Valve

Options (on request)

100% total heat recovery (available on EWWD-I-SS, condenser 1 or 2 passes) - Produced with tube bundle placed in a single shell with the water condensers. Heat exchangers heads are provided with 2 connections for entering/leaving heat recovery water and 2 separate connections for condensing water.

Partial heat recovery (available on EWWD-I-SS and -XS, condenser 1 or 2 passes) – The upper portion of the condenser has cooling tubes through which about 10% of heat rejection (mainly discharge gas superheat) of the unit is recovered. These condensers, with partial heat recovery tubes, have crowns with special couplings by which they can be connected to the hot water pipes.

Brine version – Allows the unit to operate down to -8°C leaving liquid temperature (antifreeze required).

Heat pump version

Condenser double flanges kit

20mm Evaporator/Condenser Insulation

Condenser Victaulic Kit

Cu-Ni 90-10 exchangers - to work with sea water the heat exchangers are fitted with Cu-Ni tubes and special protection inside the end covers.

Condenser 2 passes (DT 9-15°C) for EWWD-I-SS units, 4 passes (DT 9-15°C) for EWWD-I-XS units

4 General Characteristics

4 - 1 General characteristics

Suction line shut off valve - Suction shut-off valve installed on the suction of the compressor to facilitate maintenance operation.

Discharge line shut-off valves - Discharge shut-off valve installed on the discharge of the compressor to facilitate maintenance operations.

Sound Proof System - Made of sheet metal and internally insulated, the cabinet is “integral kind” (around the whole chiller, not only around the compressors) to reach the best performance in noise reduction.

Dual Pressure Relief Valve on evaporator

Soft start - Electronic starting device to reduce the mechanical stress during compressor start-up

Compressor thermal overload relays - Safety devices against compressor motor overloading in addition to the normal protection envisaged by the electrical windings.

Under/Over Voltage – This device controls the voltage value of power supply and stops the chiller if the value exceeds the allowed operating limits.

Energy Meter – This device allows to measure the energy absorbed by the chiller during its life. It is installed inside the control box mounted on a DIN rail and shows on a digital display: Line-to-Line Voltage, Phase and Average Current, Active and Reactive Power, Active Energy, Frequency.

Condenser power factor correction - Installed on the electrical control panel to ensure it conforms to the plant rules. (Daikin advises maximum 0,9).

Evaporator / condenser flow switch for the water piping.

Rubber type antivibration mounts – Supplied separately, these are positioned under the base of the unit during installation. Ideal to reduce the vibrations when the unit is floor mounted.

Witness test – Every unit is always tested at the test bench prior to the shipment. On request, a second test can be carried out, at customer’s presence, in accordance with the procedures indicated on the test form. (Not available for units with glycol mixtures).

Container kit

Acoustic test

5 Nomenclature

5 - 1 Nomenclature

5

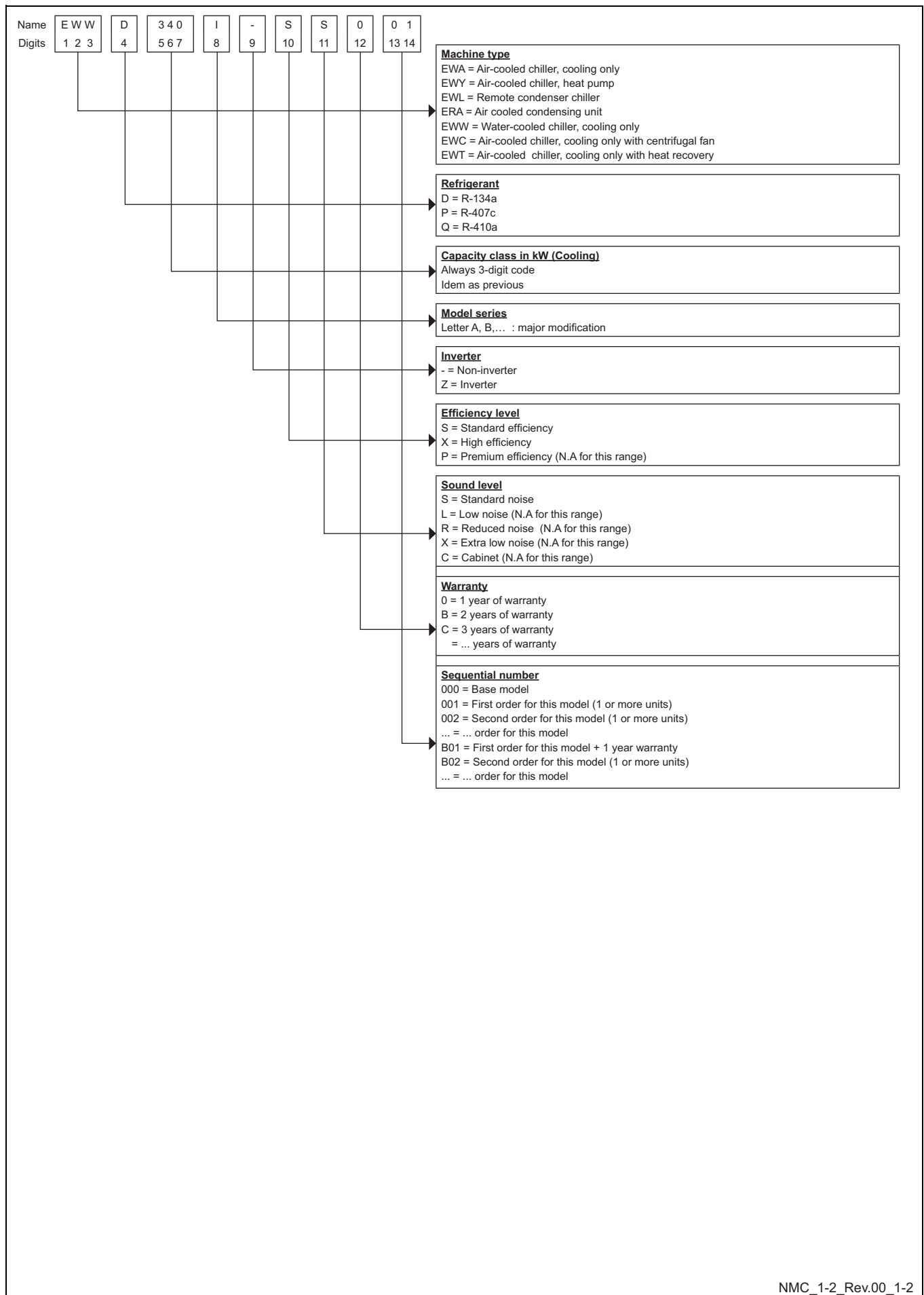

6 Capacity tables

6 - 1 Cooling/Heating Capacity Tables

EWWD360-800I-XS

Twe: Evaporator leaving water temperature (Δt 5°C); Twc: Condenser leaving water temperature (Δt 5°C)
 qwe: Fluid flow rate at evaporator; dpwe: Fluid pressure drop at evaporator
 HC: Heat capacity at condenser; qwc: Fluid flow rate at condenser; dpwc: Fluid pressure drop at condenser

Size	Condenser inlet air temperature Ta	Twtout																							
		5						7						9											
		CC kW	PI kW	qwe l/s	dpwe kPa	HC kW	qwc l/s	dpwc kPa	CC kW	PI kW	qwe l/s	dpwe kPa	HC kW	qwc l/s	dpwc kPa	CC kW	PI kW	qwe l/s	dpwe kPa	HC kW	qwc l/s	dpwc kPa			
360	30	351	66.4	16.8	61	416	20	45	377	68.3	18.1	70	443	21.3	50	404	70.3	19.4	79	472	22.7	56			
	35	335	72.7	16.0	56	406	19.6	43	360	74.5	17.3	64	433	20.9	48	387	76.5	18.6	73	461	22.2	54			
	40	319	79.7	15.2	51	397	19.2	41	343	81.4	16.4	59	423	20.4	46	368	83.4	17.7	67	450	21.7	52			
	45	302	87.8	14.4	46	388	18.8	40	325	89.3	15.6	53	413	20	44	350	91	16.8	61	439	21.2	49			
	50	284	97.2	13.6	42	380	18.4	38	307	98.3	14.7	48	403	19.6	43	330	99.8	15.8	55	428	20.8	47			
	55	266	108	12.7	37	373	18.1	37	287	109	13.8	43	395	19.2	41	310	110	14.9	49	418	20.3	46			
440	30	420	79.9	20.1	61	498	24	44	451	82.3	21.6	70	531	25.6	49	483	84.9	23.2	79	566	27.2	55			
	35	401	87.1	19.2	56	486	23.4	42	431	89.5	20.7	64	518	25	47	462	92.1	22.2	73	552	26.6	53			
	40	381	95.1	18.3	51	475	22.9	41	410	97.4	19.7	59	506	24.4	45	441	99.9	21.1	67	538	26	51			
	45	361	104	17.3	46	464	22.4	39	389	106	18.6	53	493	23.9	43	418	109	20.1	61	525	25.4	49			
	50	340	114	16.3	42	453	22	37	367	116	17.6	48	481	23.3	42	395	118	18.9	55	511	24.8	46			
	55	318	126	15.2	37	443	21.5	36	344	128	16.5	43	470	22.8	40	371	129	17.8	49	499	24.2	45			
500	30	491	93.3	23.5	61	582	28	48	527	96.1	25.3	58	621	29.9	54	565	99	27.1	66	661	31.8	60			
	35	469	102	22.4	47	569	27.4	46	504	104	24.1	54	606	29.2	51	540	107	25.9	61	645	31.1	58			
	40	446	111	21.3	43	555	26.8	44	480	114	23.0	49	591	28.6	49	515	117	24.7	56	629	30.4	55			
	45	422	122	20.2	39	542	26.2	42	455	124	21.8	45	577	27.9	47	489	127	23.4	51	613	29.7	53			
	50	398	134	19.0	35	530	25.7	41	429	136	20.5	40	563	27.3	45	462	138	22.1	46	598	29	51			
	55	373	148	17.8	31	519	25.2	39	402	149	19.3	36	550	26.7	44	434	152	20.8	41	583	28.3	49			
600	30	556	113	26.6	65	666	32.1	61	596	117	28.6	74	710	34.1	69	638	120	30.6	83	754	36.3	77			
	35	531	123	25.4	60	652	31.4	59	570	127	27.3	68	694	33.4	66	611	131	29.3	77	738	35.6	74			
	40	505	134	24.2	54	636	30.7	57	543	137	26.0	62	677	32.7	64	582	141	28.0	71	720	34.8	71			
	45	479	144	22.9	49	621	30	54	515	148	24.7	56	660	31.9	61	553	153	26.5	64	702	34	68			
	50	451	156	21.6	44	604	29.3	52	486	160	23.3	51	643	31.2	58	523	164	25.1	58	684	33.1	65			
	55	423	167	20.2	39	588	28.5	50	456	172	21.8	45	625	30.4	55	491	176	23.6	52	665	32.3	62			
750	30	700	132	33.5	55	828	19.9	45	749	135	35.9	63	881	21.2	50	801	139	38.4	71	935	22.5	56			
	35	669	144	32	51	810	19.5	43	717	148	34.4	58	861	20.8	48	767	152	36.8	66	915	22.0	54			
	40	637	159	30.5	47	793	19.1	42	684	162	32.7	53	843	20.3	47	733	165	35.1	60	894	21.6	52			
	45	605	175	28.9	43	777	18.8	40	650	178	31.1	49	824	19.9	45	697	181	33.4	55	874	21.1	50			
	50	571	193	27.3	38	762	18.5	39	614	196	29.4	44	807	19.6	43	660	198	31.6	50	855	20.7	48			
	55	536	215	25.6	34	748	18.2	38	577	216	27.6	39	791	19.2	42	621	219	29.8	45	836	20.3	46			
800	30	772	146	37	65	915	20.1	45	826	150	39.6	73	972	21.4	50	882	154	42.4	83	1032	22.7	56			
	35	739	159	35.4	60	895	19.7	43	791	163	37.9	68	951	21.0	48	846	168	40.6	77	1009	22.3	54			
	40	704	175	33.7	55	876	19.3	42	755	178	36.2	62	930	20.5	47	808	183	38.8	71	987	21.8	52			
	45	668	192	32	50	857	19.0	40	718	195	34.4	57	910	20.1	45	769	199	36.9	65	964	21.3	50			
	50	631	211	30.2	45	840	18.6	39	679	214	32.5	51	890	19.7	43	728	218	34.9	59	943	20.9	48			
	55	593	234	28.3	40	824	18.3	38	638	236	30.6	46	872	19.4	42	686	239	32.9	53	922	20.5	46			

NOTES - ANMERKUNGEN - Σημειώσεις - NOTAS - REMARQUES - NOTE - OPMERKINGEN - примечания

1 Fluid: Water
 Fluid: Wasser
 Υγρό: Νερό
 Líquido: agua
 Liquide: Eau
 Fluido: Acqua
 Vloeistof: Water
 Жидкость: Вода

2 For working conditions where dpw values are in italic, please contact factory.
 Für Arbeitsbedingungen mit kursiv gedruckten dpw-Werten, wenden Sie sich bitte an den Hersteller.
 Για τις συνθήκες εργασίας όπου οι τιμές dpw είναι σε πλάγια γραφή, παρακαλούμε επικοινωνήστε με το εργοστάσιο.
 Para las condiciones de funcionamiento en las que los valores dpw están en cursiva, póngase en contacto con la fábrica.
 Pour les conditions de travail lorsque les valeurs dpw sont en italique, veuillez contacter l'usine.
 Per le condizioni d'esercizio in cui i valori dpw sono riportati in corsivo, contattare il produttore.
 Voor bedrijfsomstandigheden met schuingedrukte dpw-waarden, gelieve contact op te nemen met de fabriek.
 Если условия работы соответствуют значениям dpw, указанным курсивом, обратитесь на завод-изготовитель.

6 Capacity tables

6 - 1 Cooling/Heating Capacity Tables

6

EWWD360-800I-XS

Twe: Evaporator leaving water temperature (Δt 5°C); Twc: Condenser leaving water temperature (Δt 5°C)
 qwe: Fluid flow rate at evaporator; dpwe: Fluid pressure drop at evaporator
 HC: Heat capacity at condenser; qwc: Fluid flow rate at condenser; dpwc: Fluid pressure drop at condenser

Size	Condenser inlet air temperature Ta	Twtout													
		11							13						
		CC kW	PI kW	qwe l/s	dpwe kPa	HC kW	qwc l/s	dpwc kPa	CC kW	PI kW	qwe l/s	dpwe kPa	HC kW	qwc l/s	dpwc kPa
360	30	433	72.4	20.8	90	503	24.2	63	462	74.7	22.3	102	534	25.7	70
	35	414	78.7	19.9	83	491	23.6	60	443	81.1	21.3	94	522	25.1	67
	40	395	85.5	19.0	76	478	23.1	58	423	87.9	20.4	86	508	24.5	64
	45	375	93	18.0	69	466	22.6	55	402	95.3	19.4	79	495	24	61
	50	355	102	17.1	63	455	22	53	381	104	18.3	71	482	23.4	59
	55	334	111	16.0	56	443	21.5	51	359	113	17.3	64	470	22.8	56
440	30	517	87.8	24.9	90	602	29	62	552	90.8	26.6	101	640	30.8	69
	35	495	94.9	23.8	83	587	28.3	59	529	97.9	25.5	94	624	30.1	66
	40	472	103	22.7	76	572	27.6	57	505	106	24.3	86	608	29.4	63
	45	449	111	21.6	69	558	27	54	481	114	23.1	79	592	28.6	60
	50	424	121	20.4	63	543	26.3	52	455	123	21.9	71	576	27.9	58
	55	399	132	19.2	56	529	25.7	50	429	134	20.6	64	561	27.2	55
500	30	604	102	29.0	75	703	33.8	67	645	106	31.0	84	746	35.9	75
	35	579	111	27.8	69	686	33.1	64	619	114	29.8	78	729	35.1	72
	40	552	120	26.5	64	669	32.3	62	591	123	28.4	72	711	34.3	69
	45	525	130	25.2	58	652	31.5	59	562	133	27.0	66	692	33.5	66
	50	496	141	23.8	52	635	30.8	56	532	144	25.6	60	674	32.6	63
	55	467	154	22.4	47	618	30	54	502	157	24.1	54	656	31.8	60
600	30	680	124	32.7	94	799	38.4	85	724	128	34.9	105	846	40.7	94
	35	652	134	31.4	87	782	37.7	82	695	138	33.5	98	828	39.9	91
	40	623	145	30.0	80	765	36.9	79	665	150	32.0	90	810	39.1	87
	45	593	157	28.5	73	746	36.1	76	634	161	30.5	83	791	38.2	84
	50	561	169	27.0	66	726	35.2	72	601	174	28.9	75	770	37.3	80
	55	528	181	25.4	59	706	34.3	69	567	186	27.2	67	749	36.4	77
750	30	854	143	41.1	80	992	<i>23.9</i> 23.9	<i>62</i> 62	910	147	43.8	90	1052	<i>25.3</i> 25.3	<i>69</i> 69
	35	819	156	39.4	74	971	<i>23.4</i> 23.4	<i>60</i> 60	874	160	42	83	1029	<i>24.8</i> 24.8	<i>67</i> 67
	40	783	169	37.6	68	948	<i>22.9</i> 22.9	<i>58</i> 58	836	174	40.2	77	1005	<i>24.3</i> 24.3	<i>64</i> 64
	45	746	185	35.8	62	926	<i>22.4</i> 22.4	<i>55</i> 55	797	189	38.3	71	981	<i>23.7</i> 23.7	<i>61</i> 61
	50	707	202	33.9	57	905	<i>21.9</i> 21.9	<i>53</i> 53	757	205	36.4	64	958	<i>23.2</i> 23.2	<i>59</i> 59
	55	667	221	32	51	884	<i>21.5</i> 21.5	<i>51</i> 51	715	225	34.3	58	935	<i>22.7</i> 22.7	<i>57</i> 57
800	30	941	159	45.2	93	1094	<i>24.1</i> 28.6	<i>62</i> 60	1001	164	48.2	105	1159	<i>25.6</i> 30.2	<i>69</i> 66
	35	903	172	43.4	87	1070	<i>23.6</i> 28.0	<i>60</i> 57	962	177	46.3	97	1134	<i>25.0</i> 29.6	<i>67</i> 64
	40	863	187	41.5	80	1046	<i>23.1</i> 27.4	<i>58</i> 55	921	192	44.3	90	1108	<i>24.5</i> 29.0	<i>64</i> 61
	45	823	203	39.5	73	1022	<i>22.6</i> 26.8	<i>55</i> 53	879	208	42.3	82	1082	<i>24.0</i> 28.4	<i>61</i> 59
	50	780	222	37.5	66	998	<i>22.1</i> 26.2	<i>53</i> 51	834	226	40.1	75	1056	<i>23.4</i> 27.7	<i>59</i> 56
	55	736	242	35.3	60	975	<i>21.7</i> 25.7	<i>51</i> 49	788	246	37.9	68	1030	<i>22.9</i> 27.1	<i>57</i> 54

NOTES - ANMERKUNGEN - Σημειώσεις - NOTAS - REMARQUES - NOTE - OPMERKINGEN - ПРИМЕЧАНИЯ

- 1 Fluid: Water
 Fluid: Wasser
 Υγρό: Νερό
 Líquido: agua
 Liquide: Eau
 Fluido: Acqua
 Vloeistof: Water
 Жидкость: Вода
- 2 For working conditions where dpw values are in italic, please contact factory.
 Für Arbeitsbedingungen mit kursiv gedruckten dpw-Werten, wenden Sie sich bitte an den Hersteller.
 Για τις συνθήκες εργασίας όπου οι τιμές dpw είναι σε πλάγια γραφή, παρακαλούμε επικοινωνήστε με το εργοστάσιο.
 Para las condiciones de funcionamiento en las que los valores dpw están en cursiva, póngase en contacto con la fábrica.
 Pour les conditions de travail lorsque les valeurs dpw sont en italique, veuillez contacter l'usine.
 Per le condizioni d'esercizio in cui i valori dpw sono riportati in corsivo, contattare il produttore.
 Voor bedrijfsomstandigheden met schuingedrukte dpw-waarden, gelieve contact op te nemen met de fabriek.
 Если условия работы соответствуют значениям dpw, указанным курсивом, обратитесь на завод-изготовитель.

SRC_1-2_Rev.02_1_(2-4)

6 Capacity tables

6 - 1 Cooling/Heating Capacity Tables

EWWD850-C12I-XS

Twe: Evaporator leaving water temperature (Δt 5°C); Twc: Condenser leaving water temperature (Δt 5°C)
 qwe: Fluid flow rate at evaporator; dpwe: Fluid pressure drop at evaporator
 HC: Heat capacity at condenser; qwc: Fluid flow rate at condenser; dpwc: Fluid pressure drop at condenser

Size	Condenser inlet air temperature Ta	Ttwot																							
		5						7						9											
		CC	PI	qwe	dpwe	HC	qwc	dpwc	CC	PI	qwe	dpwe	HC	qwc	dpwc	CC	PI	qwe	dpwe	HC	qwc	dpwc			
kW	kW	l/s	kPa	kW	l/s	kPa	kW	kW	l/s	kPa	kW	l/s	kPa	kW	kW	l/s	kPa	kW	l/s	kPa					
850	30	842	159	40.3	54	997	24.0 24.0	44 44	901	163	43.2	61	1060	25.5 25.5	49 49	962	168	46.2	69	1125	27.1 27.1	54 54			
	35	805	173	38.5	50	975	23.5 23.5	42 42	863	178	41.3	56	1036	25.0 25.0	47 47	922	183	44.2	64	1100	26.5 26.5	52 52			
	40	768	190	36.7	45	954	23.0 23.0	41 41	823	194	39.4	52	1013	24.5 24.5	45 45	881	198	42.2	58	1075	26.0 26.0	50 50			
	45	728	208	34.8	41	933	22.6 22.6	39 39	782	212	37.4	47	990	24.0 24.0	44 44	838	216	40.2	53	1050	25.4 25.4	48 48			
	50	688	228	32.9	37	913	22.1 22.1	38 38	740	232	35.4	43	968	23.5 23.5	42 42	794	236	38	48	1026	24.9 24.9	47 47			
	55	646	252	30.8	33	895	21.7 21.7	37 37	695	255	33.3	38	947	23.0 23.0	40 40	748	258	35.8	43	1002	24.3 24.3	45 45			
950	30	907	172	43.4	61	1075	24.1 27.7	44 46	970	177	46.5	69	1143	25.6 29.4	49 52	1035	183	49.7	78	1212	27.2 31.2	54 57			
	35	868	188	41.5	56	1052	23.6 27.2	42 45	929	193	44.5	64	1118	25.0 28.8	47 50	993	198	47.6	72	1186	26.6 30.6	52 55			
	40	827	206	39.6	52	1030	23.1 26.6	41 43	887	211	42.5	59	1093	24.5 28.3	45 48	949	215	45.5	66	1159	26.0 30.0	50 53			
	45	786	226	37.6	47	1008	22.6 26.1	39 42	843	230	40.4	54	1069	24.0 27.7	44 46	903	235	43.3	61	1133	25.5 29.3	48 51			
	50	742	248	35.5	42	987	22.2 25.7	38 40	797	252	38.2	49	1046	23.5 27.2	42 45	855	256	41	55	1108	24.9 28.8	47 50			
	55	697	274	33.3	38	968	21.8 25.2	37 39	750	277	35.9	43	1024	23.1 26.7	40 43	806	281	38.6	50	1083	24.4 28.2	45 48			
C10	30	948	186	45.4	69	1130	27.2 27.2	46 46	1013	191	48.6	78	1200	28.9 28.9	52 52	1081	197	51.9	88	1273	30.6 30.6	57 57			
	35	908	203	43.5	64	1107	26.7 26.7	45 45	971	208	46.6	72	1175	28.3 28.3	50 50	1037	214	49.8	81	1246	30.0 30.0	55 55			
	40	866	222	41.4	58	1085	26.2 26.2	43 43	927	227	44.5	66	1150	27.8 27.8	48 48	992	233	47.6	75	1219	29.4 29.4	53 53			
	45	822	244	39.3	53	1063	25.7 25.7	42 42	882	248	42.3	61	1126	27.2 27.2	46 46	944	253	45.3	69	1193	28.9 28.9	51 51			
	50	777	268	37.2	48	1042	25.2 25.2	40 40	835	272	40	55	1103	26.7 26.7	45 45	895	277	42.9	62	1167	28.3 28.3	50 50			
	55	730	296	34.9	43	1023	24.8 24.8	39 39	786	299	37.6	49	1081	26.3 26.3	43 43	844	303	40.5	56	1143	27.7 27.7	48 48			
C11	30	1010	204	48.3	44	1209	27.2 31.0	48 61	1080	209	51.7	50	1284	28.9 32.9	53 67	1152	215	55.2	57	1361	30.6 34.9	59 75			
	35	967	223	46.2	41	1185	26.6 30.5	46 59	1035	228	49.5	46	1257	28.3 32.3	51 65	1105	234	53	52	1333	30.0 34.3	57 72			
	40	922	243	44.1	38	1160	26.1 29.9	44 56	988	249	47.3	43	1231	27.7 31.7	49 63	1056	255	50.6	48	1305	29.4 33.6	55 70			
	45	875	264	41.8	34	1135	25.6 29.3	43 54	939	270	44.9	39	1204	27.2 31.1	47 60	1005	277	48.2	44	1276	28.8 32.9	53 67			
	50	827	288	39.5	31	1110	25.2 28.7	41 52	888	294	42.5	35	1177	26.7 30.4	46 58	952	300	45.6	40	1247	28.2 32.2	51 64			
	55	776	314	37.1	28	1086	24.7 28.0	40 50	835	319	40	32	1150	26.2 29.7	44 55	897	326	43	36	1218	27.7 31.5	49 62			
C12	30	1104	223	52.8	49	1321	31.8 31.8	61 61	1179	230	56.5	56	1402	33.7 33.7	67 67	1257	236	60.3	63	1485	35.7 35.7	75 75			
	35	1056	244	50.5	46	1295	31.2 31.2	59 59	1130	250	54.1	52	1374	33.1 33.1	65 65	1206	257	57.8	58	1456	35.1 35.1	72 72			
	40	1007	265	48.2	42	1267	30.6 30.6	56 56	1079	272	51.6	48	1344	32.5 32.5	63 63	1153	279	55.3	54	1425	34.4 34.4	70 70			
	45	957	287	45.7	38	1238	29.9 29.9	54 54	1026	294	49.1	43	1314	31.8 31.8	60 60	1098	302	52.6	49	1393	33.7 33.7	67 67			
	50	904	309	43.2	34	1209	29.3 29.3	52 52	971	317	46.4	39	1283	31.1 31.1	58 58	1040	326	49.8	45	1360	32.9 32.9	64 64			
	55	849	333	40.6	31	1178	28.6 28.6	50 50	913	342	43.7	35	1250	30.4 30.4	55 55	981	350	47	40	1325	32.2 32.2	62 62			

NOTES - ANMERKUNGEN - Σημειώσεις - NOTAS - REMARQUES - NOTE - OPMERKINGEN - примечания

- 1 Fluid: Water
 Fluid: Wasser
 Υγρό: Νερό
 Líquido: agua
 Liquide: Eau
 Fluido: Acqua
 Vloeistof: Water
 Жидкость: Вода
- 2 For working conditions where dpw values are in italic, please contact factory.
 Für Arbeitsbedingungen mit kursiv gedruckten dpw-Werten, wenden Sie sich bitte an den Hersteller.
 Για τις συνθήκες εργασίας όπου οι τιμές dpw είναι σε πλάγια γραφή, παρακαλούμε επικοινωνήστε με το εργοστάσιο.
 Para las condiciones de funcionamiento en las que los valores dpw están en cursiva, póngase en contacto con la fábrica.
 Pour les conditions de travail lorsque les valeurs dpw sont en italique, veuillez contacter l'usine.
 Per le condizioni d'esercizio in cui i valori dpw sono riportati in corsivo, contattare il produttore.
 Voor bedrijfsomstandigheden met schuingedrukte dpw-waarden, gelieve contact op te nemen met de fabriek.
 Если условия работы соответствуют значениям dpw, указанным курсивом, обратитесь на завод-изготовитель.

SRC_1-2_Rev.02_1_(3-4)

6 Capacity tables

6 - 1 Cooling/Heating Capacity Tables

EWWD850-C12I-XS

Twe: Evaporator leaving water temperature ($\Delta t 5^{\circ}\text{C}$); Twc: Condenser leaving water temperature ($\Delta t 5^{\circ}\text{C}$)
 qwe: Fluid flow rate at evaporator; dpwe: Fluid pressure drop at evaporator
 HC: Heat capacity at condenser; qwc: Fluid flow rate at condenser; dpwc: Fluid pressure drop at condenser

Size	Condenser inlet air temperature Ta	Ttwout													
		11							13						
		CC	PI	qwe	dpwe	HC	qwc	dpwc	CC	PI	qwe	dpwe	HC	qwc	dpwc
	kW	kW	l/s	kPa	kW	l/s	kPa	kW	kW	l/s	kPa	kW	l/s	kPa	
850	30	1026	173	49.3	77	1194	28.7 28.7	60 60	1092	179	52.5	87	1265	30.4 30.4	67 67
	35	984	188	47.3	72	1167	28.1 28.1	58 58	1049	193	50.5	80	1236	29.8 29.8	65 65
	40	941	203	45.2	66	1140	27.5 27.5	56 56	1004	209	48.3	74	1208	29.2 29.2	62 62
	45	897	221	43	60	1113	26.9 26.9	54 54	958	226	46	68	1179	28.5 28.5	59 59
	50	850	240	40.8	55	1086	26.3 26.3	52 52	909	245	43.7	62	1150	27.9 27.9	57 57
	55	802	262	38.5	49	1060	25.8 25.8	50 50	859	267	41.3	56	1121	27.2 27.2	55 55
950	30	1103	188	53	87	1285	28.8 33.0	60 64	1172	194	56.4	98	1359	30.5 34.9	67 70
	35	1059	204	50.9	81	1257	28.2 32.4	58 61	1127	210	54.2	91	1330	29.9 34.2	65 68
	40	1013	221	48.7	75	1228	27.6 31.7	56 59	1079	227	51.9	84	1300	29.2 33.5	62 65
	45	965	240	46.4	69	1200	27.0 31.1	54 57	1030	246	49.5	77	1270	28.6 32.9	59 63
	50	916	261	44	62	1172	26.4 30.4	52 55	979	267	47	71	1240	27.9 32.2	57 61
	55	864	285	41.5	56	1145	25.8 29.8	50 53	925	290	44.5	64	1210	27.3 31.5	55 58
C10	30	1151	203	55.3	98	1347	32.4 32.4	64 64	1222	209	58.9	110	1424	34.3 34.3	70 70
	35	1105	220	53.1	91	1319	31.8 31.8	61 61	1175	226	56.6	102	1395	33.6 33.6	68 68
	40	1058	238	50.9	84	1291	31.2 31.2	59 59	1127	245	54.2	95	1365	33.0 33.0	65 65
	45	1009	259	48.5	77	1263	30.5 30.5	57 57	1076	265	51.8	87	1335	32.3 32.3	63 63
	50	958	282	46	70	1235	29.9 29.9	55 55	1023	288	49.2	79	1305	31.6 31.6	61 61
	55	904	308	43.4	64	1207	29.3 29.3	53 53	967	313	46.5	72	1275	31.0 31.0	58 58
C11	30	1227	221	58.9	63	1441	32.5 36.9	66 83	1305	228	62.7	71	1524	34.4 38.9	73 91
	35	1178	241	56.5	59	1412	31.8 36.2	63 80	1254	247	60.2	66	1493	33.7 38.3	70 88
	40	1127	261	54.1	54	1382	31.2 35.6	61 77	1201	268	57.7	61	1461	33.0 37.6	67 85
	45	1075	283	51.5	50	1351	30.5 34.9	58 74	1146	290	55	56	1429	32.3 36.8	65 82
	50	1019	307	48.9	45	1320	29.9 34.1	56 71	1089	314	52.3	51	1396	31.6 36.1	62 79
	55	962	332	46.1	41	1289	29.2 33.3	54 68	1029	339	49.4	46	1362	30.9 35.2	60 75
C12	30	1338	242	64.2	70	1571	37.8 37.8	83 83	1420	249	68.3	79	1659	39.9 39.9	91 91
	35	1285	264	61.7	65	1540	37.1 37.1	80 80	1366	271	65.7	73	1627	39.2 39.2	88 88
	40	1230	286	59	60	1508	36.4 36.4	77 77	1309	294	62.9	68	1594	38.5 38.5	85 85
	45	1173	310	56.3	55	1475	35.7 35.7	74 74	1250	318	60.1	62	1559	37.7 37.7	82 82
	50	1113	334	53.4	50	1440	34.9 34.9	71 71	1188	343	57.1	57	1523	36.9 36.9	79 79
	55	1051	359	50.4	45	1403	34.1 34.1	68 68	1124	368	53.9	51	1484	36.0 36.0	75 75

NOTES - ANMERKUNGEN - Σημειώσεις - NOTAS - REMARQUES - NOTE - OPMERKINGEN - примечания

- 1 Fluid: Water
 Fluid: Wasser
 Υγρό: Νερό
 Líquido: agua
 Liquide: Eau
 Fluido: Acqua
 Vloeistof: Water
 Жидкость: Вода
- 2 For working conditions where dpw values are in italic, please contact factory.
 Für Arbeitsbedingungen mit kursiv gedruckten dpw-Werten, wenden Sie sich bitte an den Hersteller.
 Για τις συνθήκες εργασίας όπου οι τιμές dpw είναι σε πλάγια γραφή, παρακαλούμε επικοινωνήστε με το εργοστάσιο.
 Para las condiciones de funcionamiento en las que los valores dpw están en cursiva, póngase en contacto con la fábrica.
 Pour les conditions de travail lorsque les valeurs dpw sont en italique, veuillez contacter l'usine.
 Per le condizioni d'esercizio in cui i valori dpw sono riportati in corsivo, contattare il produttore.
 Voor bedrijfsomstandigheden met schuingedrukte dpw-waarden, gelieve contact op te nemen met de fabriek.
 Если условия работы соответствуют значениям dpw, указанным курсивом, обратитесь на завод-изготовитель.

SRC_1-2_Rev.02_1_(4-4)

6 Capacity tables

6 - 2 Partial Heat Recovery Capacity tables

Partial Heat Recovery Ratings
EWWD-I-XS

Size	ELWT (°C)	Leaving Condenser Water Temperature (°C)				
		35	40	45	50	55
		Hc (kW)	Hc (kW)	Hc (kW)	Hc (kW)	Hc (kW)
340	40	35	46	58	59	60
	45	24	35	46	54	56
	50	13	23	33	42	50
400	40	42	56	70	71	73
	45	29	42	55	65	68
	50	16	28	40	50	60
460	40	49	65	82	83	85
	45	34	49	65	76	79
	50	19	33	47	59	70
550	40	57	76	94	96	98
	45	40	57	74	88	91
	50	23	39	54	67	81
650	40	69	93	117	119	120
	45	48	70	92	109	113
	50	27	47	67	84	100
700	40	77	102	128	130	132
	45	53	77	101	119	124
	50	30	51	73	92	110
800	40	85	112	140	142	144
	45	58	84	110	130	135
	50	32	56	80	100	120
850	40	89	120	151	153	155
	45	62	90	118	140	145
	50	34	60	86	108	129
900	40	96	129	161	164	166
	45	66	97	127	150	156
	50	37	65	92	115	138
950	40	106	140	175	178	180
	45	73	106	138	163	169
	50	42	71	100	125	150
C10	40	114	150	187	190	192
	45	80	113	147	174	180
	50	46	76	107	134	160

NOTES

Leaving Evaporator Water Temperature 7°C, ΔT 5°C; ΔT Condenser Water Temperature 5°C

OPT_1-2-3-4-5-6-7-8_Rev.00_5

7 Dimensional drawings

7-1 Dimensional Drawings

7

EWWD360-600I-XS

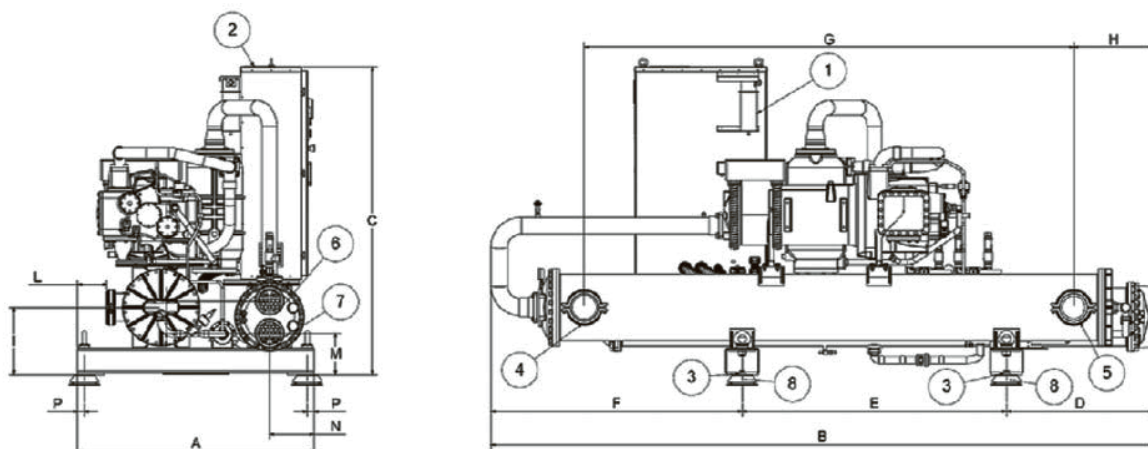

Dimensions

EWWD-I-	A	B	C	D	E	F	G	H	I	L	M	N	O	P
EWWD360-600I-XS	1430	4012	1883	890	1600	1522	2962	484	412	176	354	169	200	40

LEGEND

- 1 - Electrical Panel
- 2 - Power connections slot 150x200
- 3 - Four (4) holes Ø21 for isolator mounting
- 4 - Evaporator water inlet (Victaulic connection) [168.3mm]
- 5 - Evaporator water outlet (Victaulic connection) [168.3mm]
- 6 - Condenser water inlet connection [Ø5"]
- 7 - Condenser water outlet connection [Ø5"]
- 8 - Isolators (optional)

DMN_1-2-3a-4a-5a-6a-7-8a_Rev.01_7

EWWD750-C12I-XS

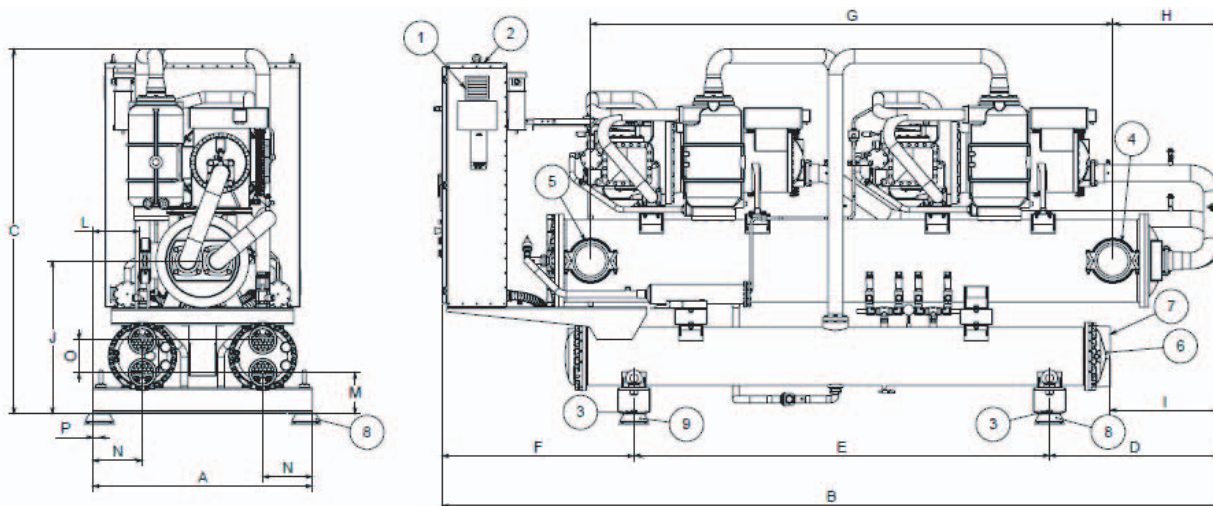

Dimensions

EWWD-I-	A	B	C	D	E	F	G	H	I	J	L	M	N	O	P
750-C12I-XS	1350	4782	2245	1048	2555	1179	3210	660	645	942	286	354	305	200	40

LEGEND

- 1 - Electrical Panel
- 2 - Power connections slot 150x200
- 3 - Four (4) holes Ø21 for isolator mounting
- 4 - Evaporator water inlet (Victaulic connection)
- 5 - Evaporator water outlet (Victaulic connection)
- 6 - Condenser water inlet connection
- 7 - Condenser water outlet connection
- 8 - Isolators (optional)

DMN_1-2-3a-4a-5a-6a-7-8a_Rev.01_8a

8 Sound data

8 - 1 Sound Level Data

Sound levels

EWWD-I-SS

Unit size	Sound pressure level at 1 m from the unit in semispheric free field (rif. 2×10^{-5} Pa)									Power	
	63 Hz	125 Hz	250 Hz	500 Hz	1000 Hz	2000 Hz	4000 Hz	8000 Hz	dB(A)	dB(A)	
340	53.6	56.2	71.1	74.5	69.7	65.6	63.9	59.5	75.2	93.7	
400	54.6	57.2	72.1	75.5	70.7	66.6	64.9	60.5	76.2	96.6	
460	56.6	59.2	74.1	77.5	72.7	68.6	66.9	62.5	78.2	96.7	
550	56.6	59.2	74.1	77.5	72.7	68.6	66.9	62.5	78.2	96.7	
650	56.2	58.8	73.7	77.1	72.3	68.2	66.5	62.1	77.8	96.9	
700	56.6	59.2	74.1	77.5	72.7	68.6	66.9	62.5	78.2	97.3	
800	57.1	59.7	74.6	78.0	73.2	69.1	67.4	63.0	78.7	97.8	
850	58.2	60.8	75.7	79.1	74.3	70.2	68.5	64.1	79.8	98.9	
900	59.1	61.7	76.6	80.0	75.2	71.1	69.4	65.0	80.7	99.8	
950	59.1	61.7	76.6	80.0	75.2	71.1	69.4	65.0	80.7	99.8	
C10	59.1	61.7	76.6	80.0	75.2	71.1	69.4	65.0	80.7	99.8	
C12	58.8	61.4	76.3	79.7	74.9	70.8	69.1	64.7	80.4	100.4	
C13	59.2	61.8	76.7	80.1	75.3	71.2	69.5	65.1	80.8	100.8	
C14	59.6	62.2	77.1	80.5	75.7	71.6	69.9	65.5	81.2	101.2	
C15	61.4	64.0	78.9	82.3	77.5	73.4	71.7	67.3	83.0	103.0	
C16	61.4	64.0	78.9	82.3	77.5	73.4	71.7	67.3	83.0	103.0	
C17	61.4	64.0	78.9	82.3	77.5	73.4	71.7	67.3	83.0	103.0	
C18	61.4	64.0	78.9	82.3	77.5	73.4	71.7	67.3	83.0	103.0	

NOTES

The values are according to ISO 3744 and are referred to: evaporator 12/7° C, condenser 30/35° C, full load operation

EWWD-I-XS

Unit size	Sound pressure level at 1 m from the unit in semispheric free field (rif. 2×10^{-5} Pa)									Power	
	63 Hz	125 Hz	250 Hz	500 Hz	1000 Hz	2000 Hz	4000 Hz	8000 Hz	dB(A)	dB(A)	
360	53.6	56.2	71.1	74.5	69.7	65.6	63.9	59.5	75.2	93.7	
440	54.6	57.2	72.1	75.5	70.7	66.6	64.9	60.5	76.2	96.6	
500	56.6	59.2	74.1	77.5	72.7	68.6	66.9	62.5	78.2	96.7	
600	56.6	59.2	74.1	77.5	72.7	68.6	66.9	62.5	78.2	96.7	
750	56.2	58.8	73.7	77.1	72.3	68.2	66.5	62.1	77.8	96.9	
800	56.6	59.2	74.1	77.5	72.7	68.6	66.9	62.5	78.2	97.3	
850	57.1	59.7	74.6	78.0	73.2	69.1	67.4	63.0	78.7	97.8	
950	58.2	60.8	75.7	79.1	74.3	70.2	68.5	64.1	79.8	98.9	
C10	59.1	61.7	76.6	80.0	75.2	71.1	69.4	65.0	80.7	99.8	
C11	59.1	61.7	76.6	80.0	75.2	71.1	69.4	65.0	80.7	99.8	
C12	59.1	61.7	76.6	80.0	75.2	71.1	69.4	65.0	80.7	99.8	

NOTES

The values are according to ISO 3744 and are referred to: evaporator 12/7° C, condenser 30/35° C, full load operation

8 Sound data

8 - 1 Sound Level Data

Sound pressure level correction factors for different distances

EWWD-I-SS

Unit size	Distance					
	1m	5m	10m	15m	20m	25m
340	0.0	-7.9	-12.7	-15.8	-18.1	-19.8
400	0.0	-7.9	-12.7	-15.8	-18.1	-19.8
460	0.0	-7.9	-12.7	-15.8	-18.1	-19.8
550	0.0	-7.9	-12.7	-15.8	-18.1	-19.8
650	0.0	-7.9	-12.7	-15.8	-18.1	-19.8
700	0.0	-7.5	-12.2	-15.3	-17.5	-19.3
800	0.0	-7.9	-12.7	-15.8	-18.1	-19.8
850	0.0	-7.5	-12.2	-15.3	-17.5	-19.3
900	0.0	-7.5	-12.2	-15.3	-17.5	-19.3
950	0.0	-7.9	-12.7	-15.8	-18.1	-19.8
C10	0.0	-7.5	-12.2	-15.3	-17.5	-19.3
C12	0.0	-7.5	-12.2	-15.3	-17.5	-19.3
C13	0.0	-7.5	-12.2	-15.3	-17.5	-19.3
C14	0.0	-7.5	-12.2	-15.3	-17.5	-19.3
C15	0.0	-7.5	-12.2	-15.3	-17.5	-19.3
C16	0.0	-7.5	-12.2	-15.3	-17.5	-19.3
C17	0.0	-7.5	-12.2	-15.3	-17.5	-19.3
C18	0.0	-7.5	-12.2	-15.3	-17.5	-19.3

EWWD-I-XS

Unit size	Distance					
	1m	5m	10m	15m	20m	25m
360	0.0	-7.9	-12.7	-15.8	-18.1	-19.8
440	0.0	-7.9	-12.7	-15.8	-18.1	-19.8
500	0.0	-7.9	-12.7	-15.8	-18.1	-19.8
600	0.0	-7.9	-12.7	-15.8	-18.1	-19.8
750	0.0	-7.9	-12.7	-15.8	-18.1	-19.8
800	0.0	-7.5	-12.2	-15.3	-17.5	-19.3
850	0.0	-7.9	-12.7	-15.8	-18.1	-19.8
950	0.0	-7.5	-12.2	-15.3	-17.5	-19.3
C10	0.0	-7.5	-12.2	-15.3	-17.5	-19.3
C11	0.0	-7.9	-12.7	-15.8	-18.1	-19.8
C12	0.0	-7.5	-12.2	-15.3	-17.5	-19.3

9 Installation

9 - 1 Installation Method

Installation notes

Warning

Installation and maintenance are to be performed only by qualified personnel who are familiar with local codes and regulations, and who are experienced with this type of equipment. Must be avoided the unit installation in places that could be considered dangerous for all the maintenance operations.

Handling

The chiller is mounted on heavy wooden skids to protect the unit from accidental damage and to permit easy handling and moving. It is recommended that all moving and handling be performed with the skids under the unit when possible and that the skids not be removed until the unit is in the final location.

If the unit must be hoisted, it is necessary to lift the unit by attaching cables or chains at the lifting holes in the evaporator tube sheets. Spreader bars must be used to protect the control cabinet and the other areas of the chiller.

Location

A leveled and sufficiently strong floor is required. If necessary, additional structural members should be provided to transfer the weight of the unit to the nearest beams.

Rubber-in-shear isolators can be furnished and field placed under each corner of the package. A rubber anti-skid pad should be used under isolators if hold-down bolts are not used. Vibration isolator in all water piping connected to the chiller is recommended to avoid straining the piping and transmitting vibration and noise.

Minimum space requirements

Every side of the machine must be accessible for all post-installation maintenance activities. The minimum space required is shown on the following drawing:

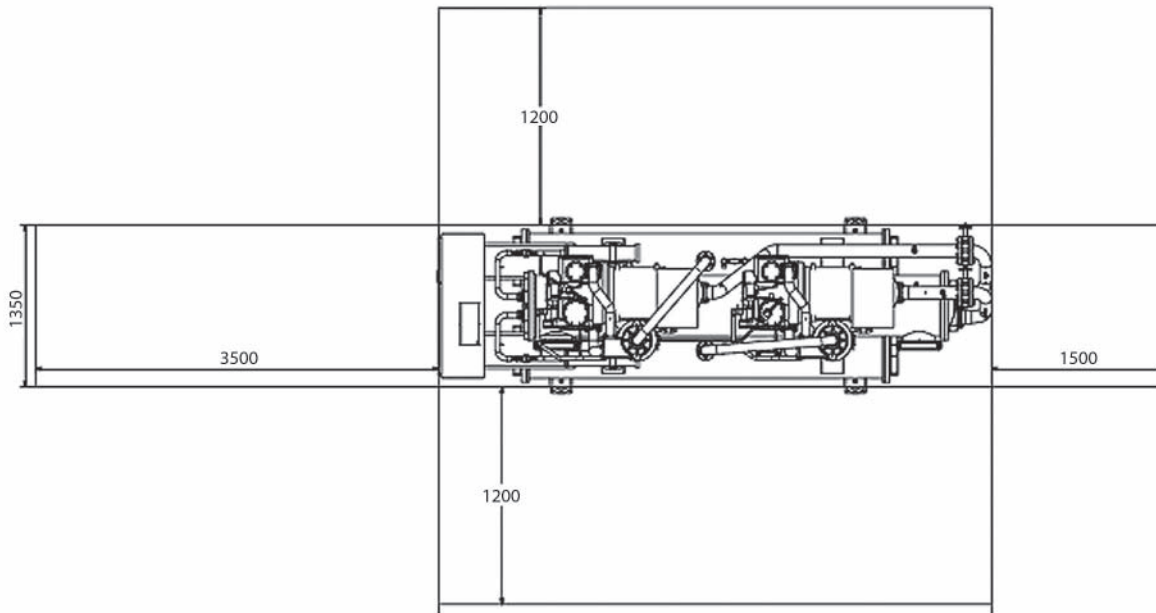

Minimum clearance requirements for machine maintenance

10 Operation range

10 - 1 Operation Range

10

Operating Limits
EWWD-I-SS --- EWWD-I-XS

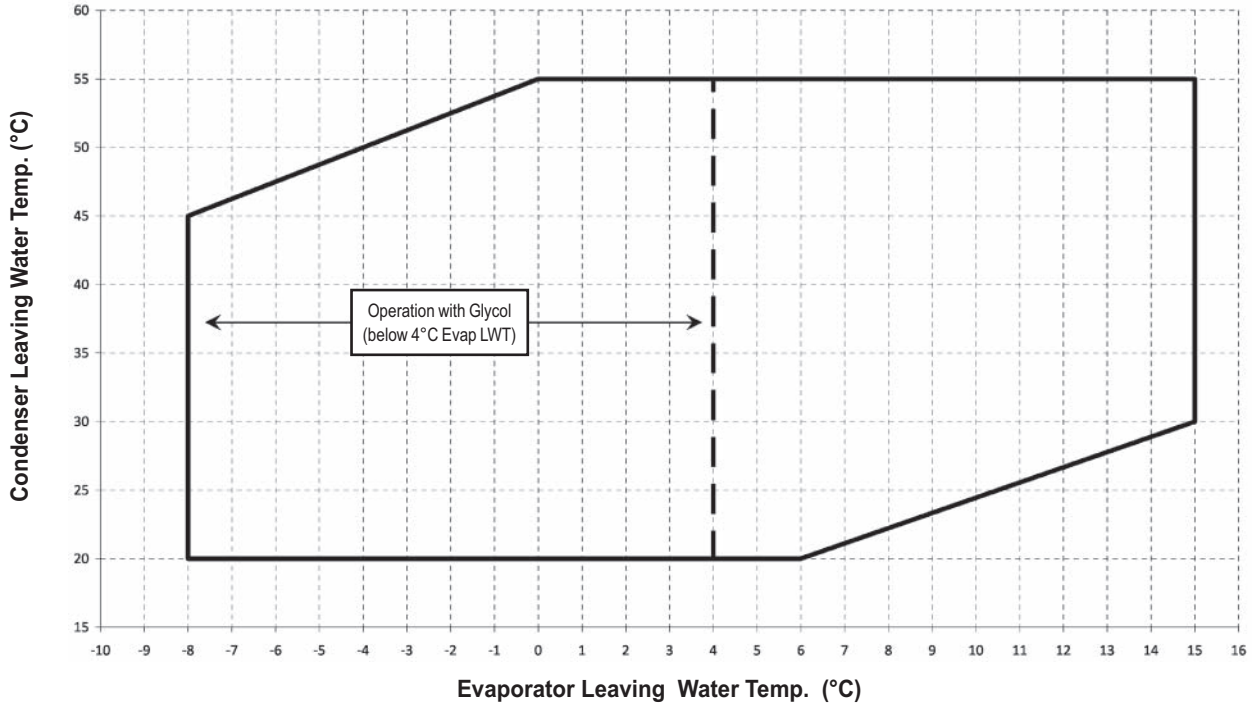

OPL_1-2-3-4a-5_Rev.01_1

10 Operation range

10 - 1 Operation Range

Table 1 - Evaporator minimum and maximum water Δt

Max evaporator water Δt	°C	8
Min evaporator water Δt	°C	4
Min condenser water Δt (1 pass, 2 passes, Δt 4÷8°C)	°C	4
Max condenser water Δt (1 pass, 2 passes, Δt 4÷8°C)	°C	8
Min condenser water ΔtT (2 passes, Δt 9÷15°C)	°C	9
Max condenser water ΔtT (2 passes, Δt 9÷15°C)	°C	15
Min condenser water ΔtT (4 passes, Δt 9÷15°C)	°C	9
Max condenser water ΔtT (4 passes, Δt 9÷15°C)	°C	15

Table 2 - Evaporator fouling factors

Fouling factors m ² °C / kW	Cooling capacity correction factor	Power input correction factor	EER correction factor
0.0176	1.000	1.000	1.000
0.0440	0.978	0.986	0.992
0.0880	0.957	0.974	0.983
0.1320	0.938	0.962	0.975

Table 3 - Condenser fouling factors

Fouling factors m ² °C / kW	Cooling capacity correction factor	Power input correction factor	EER correction factor
0.0176	1.000	1.000	1.000
0.0440	0.978	0.986	0.992
0.0880	0.957	0.974	0.983
0.1320	0.938	0.962	0.975

Table 4.1 - Minimum glycol percentage for low water temperature

Evaporator Leaving Water Temperature (°C)	2	0	-2	-4	-6	-8
Ethylene glycol (%)	10	20	20	20	30	30
Propylene glycol (%)	10	20	20	30	30	30

Note: Minimum glycol percentage to be used with evaporator leaving water temperature below 4°C to prevent freezing of water circuit.

Table 4.2 Minimum glycol percentage for low air ambient temperature

Air Ambient Temperature (°C) (2)	-3	-8	-15	-23	-35
Ethylene glycol (%) (1)	10%	20%	30%	40%	50%
Air Ambient Temperature (°C) (2)	-3	-7	-12	-20	-32
Propylene glycol (%) (1)	10%	20%	30%	40%	50%

Note (1): Minimum glycol percentage to prevent freezing of water circuit at indicated air ambient temperature.

Note (2): Air ambient temperature do exceed the operating limits of the unit, as protection of water circuit may be needed in winter season at non-working conditions.

Table 5 - Correction factors for low evaporator leaving water temperature

Evaporator Leaving Water Temperature (°C)	2	0	-2	-4	-6	-8
Cooling Capacity	0.842	0.785	0.725	0.670	0.613	0.562
Compressor Power Input	0.950	0.940	0.920	0.890	0.870	0.840

Note: Correction factors have to be applied at working conditions: evaporator leaving water temperature 7°C.

Table 6 - Correction factors for water and glycol mixture

	Ethylene Glycol (%)	10%	20%	30%	40%	50%
Ethylene Glycol	Cooling Capacity	0.991	0.982	0.972	0.961	0.946
	Compressor Power Input	0.996	0.992	0.986	0.976	0.966
	Flow Rate (Δt)	1.013	1.04	1.074	1.121	1.178
	Evaporator Pressure Drop	1.070	1.129	1.181	1.263	1.308
Propylene Glycol	Cooling Capacity	0.985	0.964	0.932	0.889	0.846
	Compressor Power Input	0.993	0.983	0.969	0.948	0.929
	Flow Rate (Δt)	1.017	1.032	1.056	1.092	1.139
	Evaporator Pressure Drop	1.120	1.272	1.496	1.792	2.128

OPL_1-2-3-4a-5_Rev.01_2

10 Operation range

10 - 1 Operation Range

10

How to use the Correction factors proposed in the previous tables

A) Mixture Water and Glycol --- Evaporator leaving water temperature > 4°C

- depending from the type and percentage (%) of glycol filled in the circuit (see table 4.2 and 6)
- multiply the Cooling Capacity, the Compressor Power Input by the Correction factor of Table 6
- starting from this new value of Cooling Capacity, calculate the Flow Rate (l/s) and the Evaporator Pressure Drop (kPa)
- now multiply the new Flow Rate and the new Evaporator Pressure Drop by the Correction Factors of Table 6

Example

Unit Size: **EWWD340I-SS**

Mixture: Water
 Working condition: ELWT 12/7°C – CLWT 30/35°C
 - Cooling capacity: 333 kW
 - Power input: 71.5 kW
 - Flow rate (Δt 5°C): 15.90 l/s
 - Evaporator pressure drop: 37kPa

Mixture: Water + Ethylene Glycol 30% (for a winter air temperature up to -15°C)
 Working condition: ELWT 12/7°C – CLWT 30/35°C
 - Cooling capacity: $333 \times 0.972 = 324 \text{ kW}$
 - Power input: $71.5 \times 0.986 = 70.5 \text{ kW}$
 - Flow rate (Δt 5°C): $15.48 \text{ (referred to } 324 \text{ kW)} \times 1.074 = 16.63 \text{ l/s}$
 - Evaporator pressure drop: $40 \text{ (referred to } 16.63 \text{ l/s)} \times 1.181 = 47\text{kPa}$

B) Mixture Water and Glycol --- Evaporator leaving water temperature < 4°C

- depending from the type and percentage (%) of glycol filled in the circuit (see table 4.1 and 4.2 and table 6)
- depending from the evaporator leaving water temperature (see table 5)
- multiply the Cooling Capacity, the Compressor Power Input by the Correction factor of Table 5 and Table 6
- starting from this new value of Cooling Capacity, calculate the Flow Rate (l/s) and the Evaporator Pressure Drop (kPa)
- now multiply the new Flow Rate and the new Evaporator Pressure Drop by the Correction Factors of Table 6

Example

Unit Size: **EWWD340I-SS**

Mixture: Water
 Standard working condition: ELWT 12/7°C – CLWT 35/40°C
 - Cooling capacity: 317 kW
 - Power input: 78.9 kW
 - Flow rate (Δt 5°C): 15.15 l/s
 - Evaporator pressure drop: 34 kPa

Mixture: Water + Glycol 30% (for a low evaporator leaving temperature of -1/-6°C)
 Working condition: ELWT -1/-6°C – CLWT 35/40°C
 - Cooling capacity: $317 \times 0.613 \times 0.972 = 189 \text{ kW}$
 - Power input: $78.9 \times 0.870 \times 0.986 = 67.7 \text{ kW}$
 - Flow rate (Δt 5°C): $9.03 \text{ l/s (referred to } 189 \text{ kW)} \times 1.074 = 9.70 \text{ l/s}$
 - Evaporator pressure drop: $15 \text{ kPa (referred to } 9.70 \text{ l/s)} \times 1.181 = 18 \text{ kPa}$

10 Operation range

10 - 1 Operation Range

Water charge, flow and quality

Items ^{(1) (6)}		Cooling Water			Cooled Water		Heated water ⁽²⁾				Tendency if out of criteria	
		Circulating System		Once Flow			Low temperature		High temperature			
		Circulating water	Supply water ⁽⁴⁾	Flowing water	Circulating water [Below 20°C]	Supply water ⁽⁴⁾	Circulating water [20°C ~ 60°C]	Supply water ⁽⁴⁾	Circulating water [60°C ~ 80°C]	Supply water ⁽⁴⁾		
Items to be controlled	pH	at 25°C	6.5 ~ 8.2	6.0 ~ 8.0	6.0 ~ 8.0	6.8 - 8.0	6.0 ~ 8.0	7.0 ~ 8.0	7.0 ~ 8.0	7.0 ~ 8.0	7.0 ~ 8.0	Corrosion + Scale
	Electrical conductivity	[mS/m] at 25°C	Below 80	Below 30	Below 40	Below 80	Below 80	Below 30	Below 30	Below 30	Below 30	Corrosion + Scale
		[µS/cm] at 25°C	(Below 800)	(Below 300)	(Below 400)	(Below 800)	(Below 800)	(Below 300)	(Below 300)	(Below 300)	(Below 300)	Corrosion + Scale
	Chloride ion	[mgCl ⁻² /l]	Below 200	Below 50	Below 50	Below 200	Below 50	Below 50	Below 50	Below 30	Below 30	Corrosion
	Sulfate ion	[mgSO ²⁻⁴ /l]	Below 200	Below 50	Below 50	Below 200	Below 50	Below 50	Below 50	Below 30	Below 30	Corrosion
	M-alkalinity (pH4.8)	[mgCaCO ³ /l]	Below 100	Below 50	Below 50	Below 100	Below 50	Below 50	Below 50	Below 50	Below 50	Scale
	Total hardness	[mgCaCO ³ /l]	Below 200	Below 70	Below 70	Below 200	Below 70	Below 70	Below 70	Below 70	Below 70	Scale
	Calcium hardness	[mgCaCO ³ /l]	Below 150	Below 50	Below 50	Below 50	Below 50	Below 50	Below 50	Below 50	Below 50	Scale
	Silica ion	[mgSiO ² /l]	Below 50	Below 30	Below 30	Below 30	Below 30	Below 30	Below 30	Below 30	Below 30	Scale
	Oxygen	(mg O ² /l)	Below 1.0	Below 1.0	Below 1.0	Below 1.0	Below 1.0	Below 1.0	Below 1.0	Below 1.0	Below 1.0	Corrosion
	Particulate size	(mm)	Below 0.5	Below 0.5	Below 0.5	Below 0.5	Below 0.6	Below 0.5	Below 0.6	Below 0.5	Below 0.6	Erosion
	Total dissolved solids	(mg / l)	Below 1000	Below 1000	Below 1000	Below 1000	Below 1001	Below 1000	Below 1001	Below 1000	Below 1001	Erosion
	Ethykene, Propylene Glycol (weight conc.)		Below 60%	Below 60%	---	Below 60%	Below 60%	Below 60%	Below 60%	Below 60%	Below 60%	--
Items to be referred to	Nitrate ion	(mg NO ³⁻ /l)	Below 100	Below 100	Below 100	Below 100	Below 101	Below 100	Below 101	Below 100	Below 101	Corrosion
	TOC Total organic carbon	(mg /l)	Below 1.0	Below 1.0	Below 1.0	Below 1.0	Below 1.0	Below 1.0	Below 1.0	Below 1.0	Below 1.0	Scale
	Iron	[mgFe/l]	Below 1.0	Below 0.3	Below 1.0	Below 1.0	Below 0.3	Below 1.0	Below 0.3	Below 1.0	Below 0.3	Corrosion + Scale
	Copper	[mgCu/l]	Below 0.3	Below 0.1	Below 1.0	Below 1.0	Below 1.0	Below 1.0	Below 0.1	Below 1.0	Below 0.1	Corrosion
	Sulfite ion	[mgS ²⁻ /l]	Not detectable	Not detectable	Not detectable	Not detectable	Not detectable	Not detectable	Not detectable	Not detectable	Not detectable	Corrosion
	Ammonium ion	[mgNH ⁺⁴ /l]	Below 1.0	Below 0.1	Below 1.0	Below 1.0	Below 0.1	Below 0.3	Below 0.1	Below 0.1	Below 0.1	Corrosion
	Remaining chloride	[mgCL/l]	Below 0.3	Below 0.3	Below 0.3	Below 0.3	Below 0.3	Below 0.25	Below 0.3	Below 0.1	Below 0.3	Corrosion
	Free carbide	[mgCO ² /l]	Below 4.0	Below 4.0	Below 4.0	Below 4.0	Below 4.0	Below 0.4	Below 4.0	Below 0.4	Below 4.0	Corrosion
	Stability index		6.0 ~ 7.0	---	---	---	---	---	---	---	---	Corrosion + Scale

NOTES

- Names, definitions and units are according to JIS K 0101. Units and figures between brackets are old units published as reference only.
- In case of using heated water (more than 40°C), corrosion is generally noticeable.
Especially when the iron materials is in direct contact with water without any protection shields, it is desirable to give the valid measure for corrosion. E.g. chemical measure.
- In the cooling water using hermetic cooling tower, close circuit water is according to heated water standard, and scattered water is according to cooling water standard.
- Supply water is considered drink water, industrial water and ground water except for genuine water, neutral water and soft water.
- The above mentioned items are representable items in corrosion and scale cases.
- The limits above have to be considered as a general prescription and can not totally assure the absence of corrosion and erosion.
Some particular combinations of elements or the presence of components not listed in the table or factors not considered may trigger corrosion phenomena.

OPL_1-2-3-4a-5_Rev.01_4a

10 Operation range

10 - 1 Operation Range

10

Water content in cooling circuits

The cooled water distribution circuits should have minimum water content to avoid excessive compressors start and stop. In fact, each time the compressor starts up, an excessive quantity of oil goes from the compressor sump and simultaneously there is a rise in the temperature of the compressor motor's stator due to the inrush current during the start-up. To prevent damage to the compressors, it has been envisaged the application of a device to limit frequent stops and restarts.

During the span of one hour there will be no more than 6 starts of the compressor. The plant side should therefore ensure that the overall water content allows a more constant functioning of the unit and consequently greater environmental comfort. The minimum water content per unit should be calculated using this simplified formula:

For 1 compressor unit

$$M \text{ (liters)} = (0.94 \times \Delta T(^{\circ}\text{C}) + 5.87) \times P(\text{kW})$$

For 2 compressors unit

$$M \text{ (liters)} = (0.1595 \times \Delta T(^{\circ}\text{C}) + 3.0825) \times P(\text{kW})$$

For 3 compressors unit

$$M \text{ (liters)} = (0.0443 \times \Delta T(^{\circ}\text{C}) + 1.6202) \times P(\text{kW})$$

where:

M	minimum water content per unit expressed in litres
P	Cooling Capacity of the unit expressed in kW
ΔT	evaporator entering / leaving water temperature difference expressed in $^{\circ}\text{C}$

This formula is valid for:

- standard microprocessor parameters

For more accurate determination of quantity of water, it is advisable to contact the designer of the plant.

11 Hydraulic performance

11 - 1 Water Pressure Drop Curve Evaporator/Condenser

Pressure Drops

EWWD-I-SS

Size	340	400	460	550	650	700	800	850	900	950	C10	C12	C13	C14	C15	C16	C17	C18
Cooling Capacity (kW)	333	394	460	538	640	705	782	844	910	986	1027	1155	1204	1274	1346	1401	1455	1510
Water Flow (l/s) - Evaporator	15.91	18.82	21.98	25.70	30.58	33.68	37.36	40.32	43.48	47.11	49.07	55.18	57.52	60.87	64.31	66.94	69.52	72.14
Evaporator Pressure Drops (kPa)	37	50	54	62	55	44	58	53	53	66	51	52	56	47	58	62	66	71
Water Flow (l/s) - Condenser	19.33	22.92	26.80	31.44	37.31	41.14	45.53	49.21	53.03	57.52	60.39	67.32	70.33	74.34	78.55	82.08	85.52	89.01
Condenser Pressure Drops (kPa)	26	28	30	26	25	25	28	28	26	23	24	24	24	25	24	24	24	23

Water flow and pressure drop referred to nominal condition: evaporator water in/out: 12/7°C – condenser water in/out: 30/35°C

EWWD-I-XS

Size	360	440	500	600	750	800	850	950	C10	C11	C12
Cooling Capacity (kW)	362	433	506	573	720	795	866	933	976	1038	1134
Water Flow (l/s) - Evaporator	17.30	20.69	24.18	27.38	34.40	37.98	41.38	44.58	46.63	49.59	54.18
Evaporator Pressure Drops (kPa)	64	48	54	68	48	48	47	50	72	46	52
Water Flow (l/s) - Condenser	20.69	24.77	28.95	33.16	41.16	45.42	49.50	51.79	56.14	60.22	65.64
Condenser Pressure Drops (kPa)	48	47	51	66	48	48	47	50	50	65	65

Water flow and pressure drop referred to nominal condition: evaporator water in/out: 12/7°C – condenser water in/out: 30/35°C

EPD_1a-2_Rev.01_1

Evaporator and Condenser Pressure Drops

To determinate the evaporator or condenser pressure drop for different versions or at different working condition, please refer to the following formula:

$$PD_2 \text{ (kPa)} = PD_1 \text{ (kPa)} \times \left(\frac{Q_2 \text{ (l/s)}}{Q_1 \text{ (l/s)}} \right)^{1.8}$$

where:

PD_2 Pressure drop to be determinated (kPa)

PD_1 Pressure drop at nominal condition (kPa)

Q_2 water flow at new working condition (l/s)

Q_1 water flow at nominal condition (l/s)

How to use the formula: Example (evaporator)

The unit EWWD340I-SS has been selected for working at the following conditions:

- evaporator water in/out: 11/6°C

- condenser water in/out: 30/35°C

The cooling capacity at these working conditions is: 322 kW

The evaporator water flow at these working conditions is: 15.38 l/s

The unit EWWD340I-SS at nominal working conditions has the following data:

- evaporator water in/out: 12/7°C

- condenser water in/out: 30/35°C

The cooling capacity at these working conditions is: 333 kW

The evaporator water flow at these working conditions is: 15.90 l/s

The evaporator pressure drop at these working conditions is: 37 kPa

The evaporator pressure drop at the selected working condition will be:

$$PD_2 \text{ (kPa)} = 37 \text{ (kPa)} \times \left(\frac{15,38 \text{ (l/s)}}{15,90 \text{ (l/s)}} \right)^{1.8}$$

$$PD_2 \text{ (kPa)} = 35 \text{ (kPa)}$$

NOTE - Important

If the calculated evaporator water pressure drop is below 10 kPa or above 100 kPa please contact the factory for dedicated evaporator.

EPD_1a-2_Rev.01_2

11 Hydraulic performance

11 - 2 Partial Heat Recovery Pressure Drop

11

Partial Heat Recovery pressure drops

EWWD-I-SS

Size EWWD-I-SS	340	400	460	550	650	700	800	850	900	950	C10	C12	C13	C14	C15	C16	C17	C18
Heating Capacity (kW)	24.5	27.5	35.5	40	48	51	54	62	70	73	76	92	94.3	97.9	102	105	109	126
Water Flow (l/s)	1.17	1.31	1.70	1.89	2.30	2.43	2.59	2.95	3.33	3.50	3.63	4.38	4.51	4.68	4.87	5.02	5.21	6.02
Heat Recovery Pressure Drops (kPa)	97	103	88	106	90	99	111	91	87	96	98	65	68	73	79	83	89	115

NOTES

Water flow and pressure drop referred to nominal condition: evaporator water in/out: 12/7°C – condenser water in/out: 30/35°C – water heat recovery in/out 40/45°C

EWWD-I-XS

Size EWWD-I-XS	360	440	500	600	750	800	850	950	C10	C11	C12
Heating Capacity (kW)	23.8	29.2	33.7	40.2	47.8	52.9	58.3	61.6	66.4	73.4	79.6
Water Flow (l/s)	1.14	1.40	1.61	1.92	2.28	2.53	2.79	2.94	3.17	3.51	3.80
Heat Recovery Pressure Drops (kPa)	17	25	31	44	17	20	25	27	31	37	43

NOTES

Water flow and pressure drop referred to nominal condition: evaporator water in/out: 12/7°C – condenser water in/out: 30/35°C – water heat recovery in/out 40/45°C

OPT_1-2-3-4-5-6-7-8_Rev.00_7

11 Hydraulic performance

11 - 3 Total Heat Recovery Pressure Drop

Total and Partial Heat Recovery Pressure Drops

To determinate the pressure drop for different versions or at different working condition, please refer to the following formula:

$$PD_2 \text{ (kPa)} = PD_1 \text{ (kPa)} \times \left(\frac{Q_2 \text{ (l/s)}}{Q_1 \text{ (l/s)}} \right)^{1.80}$$

where:

- PD_2 Pressure drop to be determinated (kPa)
- PD_1 Pressure drop at nominal condition (kPa)
- Q_2 water flow at new working condition (l/s)
- Q_1 water flow at nominal condition (l/s)

How to use the formula: Example

The unit EWWD360I-XS has been selected for working at the following conditions:

- evaporator water in/out: 12/7°C
 - condenser water in/out: 30/35°C
 - Partial heat recovery leaving water temperature 45/50°C
- The heating capacity at these working conditions is: 13.2 kW
The water flow at these working conditions is: 0.63 l/s

The unit EWWD360I-XS at nominal working conditions has the following data:

- evaporator water in/out: 12/7°C
 - condenser water in/out: 30/35°C
 - Partial heat recovery leaving water temperature 40/45°C
- The heating capacity at these working conditions is: 23.8 kW
The water flow at these working conditions is: 1.14 l/s
The pressure drop at these working conditions is: 17 kPa

The pressure drop at the selected working condition will be:

$$PD_2 \text{ (kPa)} = 17 \text{ (kPa)} \times \left(\frac{0.63 \text{ (l/s)}}{1.14 \text{ (l/s)}} \right)^{1.80}$$

$$PD_2 \text{ (kPa)} = 6 \text{ (kPa)}$$

OPT_1-2-3-4-5-6-7-8_Rev.00_8

12 Specification text

12 - 1 Specification Text

12

Technical Specification for Water Cooled Screw Chiller

GENERAL

The water cooled screw chiller will be designed and manufactured in accordance with following European directives:

Construction of pressure vessel	97/23/EC (PED)
Machinery Directive	2006/42/EC
Low Voltage	2006/95/EC
Electromagnetic Compatibility	2004/108/EC
Electrical & Safety codes	EN 60204-1 / EN 60335-2-40
Manufacturing Quality Stds	UNI – EN ISO 9001:2004

The unit will be tested at full load in the factory at the nominal working conditions and water temperatures. Before shipment a full test will be held to avoid any losses.

Chiller will be delivered to the job site completely assembled and charged with right refrigerant and oil quantity. Comply with the manufacturer instructions for rigging and handling equipment.

The unit will be able to start up and operate as standard at full load and condenser entering fluid temperature from °C to °C with an evaporator leaving fluid temperature between °C and °C.

All units published performances have to be certified by **Eurovent**.

REFRIGERANT

Only R-134a will be accepted.

PERFORMANCE

- ✓ Number of water cooled screw chiller:
- ✓ Cooling capacity for single water cooled screw chiller: kW
- ✓ Power input for single water cooled screw chiller in cooling mode: kW
- ✓ Shell & tube evaporator entering water temperature in cooling mode: °C
- ✓ Shell & tube evaporator leaving water temperature in cooling mode: °C
- ✓ Shell & tube evaporator water flow: l/s
- ✓ Shell & tube condenser entering water temperature in cooling mode: °C
- ✓ Shell & tube condenser leaving water temperature in cooling mode: °C
- ✓ Shell & tube condenser water flow: l/s
- ✓ The unit should work with electricity in range 400V ±10%, 3ph, 50Hz without neutral and shall only have one power connection point.

UNIT DESCRIPTION

Chiller shall include as standard: 1, 2 or 3 independent refrigerant circuits, semi-hermetic rotary single screw compressors, electronic expansion device (EEXV), refrigerant direct expansion shell & tube heat exchangers, R134a refrigerant, lubrication system, motor starting components, control system and all components necessary for safe and stable unit operation. Chiller will be factory assembled on a robust base-frame made of zinc coated steel, protected by an epoxy paint.

NOISE LEVEL AND VIBRATIONS

Sound pressure level at 1 meter distance in free field, semispheric conditions, shall not exceeddB(A). The sound pressure levels must be rated in accordance to ISO 3744. Other types of rating unacceptable. Vibration level should not exceed 2 mm/s.

DIMENSIONS

Unit dimensions shall not exceed following indications:

- ✓ unit length mm,
- ✓ unit width mm,
- ✓ unit height mm.

SPC_1-2-3_Rev.00_1

12 Specification text

12 - 1 Specification Text

CHILLER COMPONENTS

Compressors

- ✓ Semi-hermetic, single-screw type with one main helical rotor meshing with gaterotor. The gaterotor will be constructed of a carbon impregnated engineered composite material. The gaterotor supports will be constructed of cast iron.
- ✓ The oil injection shall be used in order to get high EER (Energy Efficiency Ratio) also at high condensing pressure and low sound pressure levels in each load condition.
- ✓ Refrigerant system differential pressure shall provide oil flow through service replaceable, 0.5 micron, full flow, cartridge type oil filter internal to compressor.
- ✓ Refrigerant system differential pressure shall provide oil injection on all moving compressor parts to correctly lubricate them. Electrical oil pump lubricating system is not acceptable.
- ✓ The compressor's oil cooling must be realized, when necessary, by refrigerant liquid injection. External dedicated heat exchanger and additional piping to carry the oil from the compressor to heat exchanger and viceversa will not be accepted.
- ✓ The compressor shall be provided with an external, high efficiency, cyclonic type oil separator and with built-in oil filter, cartridge type.
- ✓ The compressor shall be direct electrical driven, without gear transmission between the screw and the electrical motor.
- ✓ Shall be present two thermal protection realized by a thermistor for high temperature protection: one temperature sensor to protect electrical motor and another sensor to protect unit and lubricating oil from high discharge gas temperature.
- ✓ The compressor shall be equipped with an electric oil-crankcase heater.
- ✓ Compressor shall be fully field serviceable. Compressor that must be removed and returned to the factory for service shall be unacceptable.

Cooling capacity control system

- ✓ Each unit will have a microprocessor for the control of compressor slide valve's position and the instantaneous RPM value of the motor.
- ✓ The unit capacity control shall be infinitely modulating, from 100% down to 25% for each circuit (from 100% down to 12.5% of full load for unit with 2 compressors and 8.3% for units with 3 compressors). The chiller shall be capable of stable operation to a minimum of 12.5% of full load without hot gas bypass.
- ✓ Step unloading unacceptable because of evaporator leaving water temperature fluctuation and low unit efficiency at partial load.
- ✓ The system shall stage the unit based on the leaving evaporator water temperature that shall be controlled by a PID (Proportional Integral Derivative) loop.
- ✓ Unit control logic shall manage frequency level of the compressor electric motor to exactly match plant load request in order to keep constant the set point for delivered chilled water temperature. In this operating condition unit control logic shall modulate electrical frequency level in a range lower and upper the nominal electrical network value fixed at 50 Hz.
- ✓ The microprocessor unit control shall detect conditions that approach protective limits and take self-corrective action prior to an alarm occurring. The system shall automatically reduce chiller capacity when any of the following parameters are outside their normal operating range:
 - o High condenser pressure
 - o Low evaporation refrigerant temperature
 - o High compressor motor amps

Evaporator

- ✓ The units shall be supplied with shell and tubes counter-flow heat exchanger with single refrigerant pass. It will be refrigerant direct expansion type with refrigerant inside the tubes and water outside (shell side). It will include carbon steel tube sheets, with straight copper tubes internally wound for higher efficiencies, expanded on the tube plates.
- ✓ The evaporator will have 2 circuits, one for each compressor and shall be single refrigerant pass.
- ✓ The water connections shall be VICTAULIC type connections as standard to ensure quick mechanical disconnection between the unit and the hydronic network.
- ✓ Evaporator is manufactured in accordance to PED approval.

SPC_1-2-3_Rev.00_2

12 Specification text

12 - 1 Specification Text

Condensers

- ✓ Condensers will be shell and cleanable, through-tube type.
- ✓ The unit will have one condenser per circuit.
- ✓ Each condenser shall have a carbon steel and seamless, integrally finned high efficiency copper tubes, roll expanded into heavy carbon steel tube sheets.
- ✓ Water heads shall be removable and include vent and drain plugs.
- ✓ Condensers will come complete with liquid shut-off valve, spring loaded relief valve.

Refrigerant circuit

Each circuit shall include as standard: electronic expansion device piloted by unit's microprocessor control, compressor discharge shut-off valve, suction line shut-off valve, replaceable core filter-drier, sight glass with moisture indicator and insulated suction line.

Control panel

- ✓ Field power connection, control interlock terminals, and unit control system should be centrally located in an electric panel (IP 54). Power and starting controls should be separate from safety and operating controls in different compartments of the same panel.
- ✓ Starting shall be Wye-Delta type as standard.
- ✓ Operating and safety controls should include energy saving control; emergency stop switch; overload protection for compressor motor; high and low pressure cut-out switch (for each refrigerant circuit); anti-freeze thermostat; cut-out switch for each compressor.
- ✓ All of the information regarding the unit will be reported on a display and with the internal built-in calendar and clock that will switch the unit ON/OFF during day time all year long.
- ✓ The following features and functions shall be included:
 - resetting chilled water temperature by controlling the return water temperature or by a remote 4-20 mA DC signal or by controlling the external ambient temperature;
 - soft load function to prevent the system from operating at full load during the chilled fluid pulldown period;
 - password protection of critical parameters of control;
 - start-to-start and stop-to-start timers to provide minimum compressor off-time with maximum motor protection;
 - communication capability with a PC or remote monitoring;
 - discharge pressure control through intelligent cycling of condenser fans;
 - lead-lag selection by manual or automatically by circuit run hours;
 - double set point for brine unit version;
 - scheduling via internal time clock to allow programming of a yearly start-stop schedule accommodating weekends and holidays.

Optional High Level Communications Interface

The controller as a minimum shall be capable of providing the data shown in the above list, using the following options:

- RS485 Serial card
- RS232 Serial card
- LonWorks interface to FTT10A Transceiver.
- Bacnet Compatible
- Use of Compass Points (manufactured by North Communications) to allow communications with such as Honeywell, Satchwell, Johnson Controls, Trend etc.



Daikin's unique position as a manufacturer of air conditioning equipment, compressors and refrigerants has led to its close involvement in environmental issues. For several years Daikin has had the intention to become a leader in the provision of products that have limited impact on the environment. This challenge demands the eco design and development of a wide range of products and an energy management system, resulting in energy conservation and a reduction of waste.



Daikin Europe N.V. participates in the Eurovent Certification programme for Air conditioners (AC), Liquid Chilling Packages (LCP) and Fan coil units (FCU). Check on-going validity of certificate online: www.eurovent-certification.com or using: www.certiflash.com

The present leaflet is drawn up by way of information only and does not constitute an offer binding upon Daikin Europe N.V.. Daikin Europe N.V. has compiled the content of this leaflet to the best of its knowledge. No express or implied warranty is given for the completeness, accuracy, reliability or fitness for particular purpose of its content and the products and services presented therein. Specifications are subject to change without prior notice. Daikin Europe N.V. explicitly rejects any liability for any direct or indirect damage, in the broadest sense, arising from or related to the use and/or interpretation of this leaflet. All content is copyrighted by Daikin Europe N.V.

BARCODE

Daikin products are distributed by:

