



Applied Systems Technical Data

Air cooled chiller, premium efficiency, reduced sound



EEEN13-417

EWAD-C-PR

TABLE OF CONTENTS

EWAD-C-PR

1	Features	2
2	Specifications	3
	Technical Specifications	3
	Electrical Specifications	4
3	Features and advantages	5
	Features and Advantages	5
4	General Characteristics	7
	General characteristics	7
5	Nomenclature	11
	Nomenclature	11
6	Options	12
	Water Pump Kit - Technical Information	12
	Water Pump Kit - Combination Matrix	14
7	Capacity tables	15
	Cooling Capacity Tables	15
8	Dimensional drawings	16
	Dimensional Drawings	16
9	Sound data	17
	Sound Power Spectrum	17
10	Installation	19
	Installation Method	19
11	Operation range	20
	Operation Range	20
12	Hydraulic performance	22
	Water Pressure Drop Curve Evaporator	22
13	Specification text	23
	Specification Text	23

1 Features

- Premium efficiency, reduced sound levels
- Stepless single-screw compressor
- Best in class energy efficiency (EER up to 3.7 and ESEER up to 4.63)
- Large operation range (ambient temperature down to -18°C and up to 52°C)
- All models are PED pressure vessel approved
- Optimised for use with R-134a
- 2 truly independent refrigerant circuits
- Standard electronic expansion valve
- DX shell and tube evaporator – one pass refrigerant side to minimize pressure drops
- Partial and total heat recovery option available
- MicroTech III controller



2 Specifications

2-1 Technical Specifications				EWAD810 C-PR	EWAD880 C-PR	EWAD960 C-PR	EWADC1 0C-PR	EWADC1 1C-PR	EWADC1 3C-PR	EWADC1 4C-PR	EWADC1 5C-PR	EWADC1 6C-PR											
Cooling capacity	Nom.	kW		806 (1)	871 (1)	954 (1)	1,049 (1)	1,127 (1)	1,246 (1)	1,353 (1)	1,432 (1)	1,513 (1)											
Capacity control	Method			Stepless																			
	Minimum capacity			13																			
Power input	Cooling	Nom.	kW		222 (1)	248 (1)	275 (1)	303 (1)	335 (1)	369 (1)	402 (1)	432 (1)	465 (1)										
EER				3.63 (1)	3.51 (1)	3.47 (1)	3.46 (1)	3.36 (1)	3.38 (1)	3.36 (1)	3.32 (1)	3.26 (1)											
ESEER				4.39	4.33	4.40	4.35	4.24	4.30	4.26	4.21	4.14											
IPLV				5.04	4.89		4.86	4.82	4.81	4.82	4.83	4.79											
Casing	Colour			Ivory white																			
	Material			Galvanized and painted steel sheet																			
Dimensions	Unit	Height	mm		2,540																		
		Width	mm		2,285																		
		Depth	mm		8,885		9,785		11,085		11,985												
Weight	Unit		kg		7,820		7,950		8,580		8,840		10,380		10,720								
	Operation weight		kg		8,420		8,990		9,620		9,880		10,670		11,010								
Water heat exchanger	Type			Single pass shell & tube																			
	Water volume			l		599		1,043		1,027		995		979									
	Nominal water flow	Cooling		l/s		38.6		41.7		45.6		50.2		54.0		59.7		64.8		68.7		72.6	
	Nominal water pressure drop	Cooling	Heat exchanger	kPa		56		65		30		59		67		58		67		77		84	
	Insulation material			Closed cell																			
Air heat exchanger	Type			High efficiency fin and tube type with integral subcooler																			
Fan	Quantity			18		20		22		24													
	Type			Direct propeller																			
	Diameter			mm		800																	
	Air flow rate	Nom.		l/s		73,813		82,014		90,216		98,417											
	Speed			rpm		700																	
Fan motor	Drive			Direct on line																			
	Input	Cooling	W		14,100		15,700		17,300		18,800												
Sound power level	Cooling	Nom.		dBA		93		94		95													
Sound pressure level	Cooling	Nom.		dBA		71		72		73													
Compressor	Type			asymmetric single screw compressor																			
	Quantity			2																			
	Oil	Charged volume		l		38		44		50													
Operation range	Water side	Cooling	Min.	°CDB		-8																	
			Max.	°CDB		15																	
	Air side	Cooling	Min.	°CDB		-18																	
			Max.	°CDB		52																	
Refrigerant	Type			R-134a																			
	Circuits	Quantity			2																		
Refrigerant circuit	Charge		kg		204		202		204		220		252		254								
Piping connections	Evaporator water inlet/outlet (OD)			219.1mm		273mm																	
Safety devices	Item	01		High discharge pressure (pressure switch)																			
		02		High discharge pressure (pressure transducer)																			
		03		Low suction pressure (pressure transducer)																			
		04		Compressor motor protection																			
		05		High discharge temperature																			
		06		Low oil pressure																			
		07		Low pressure ratio																			
		08		High oil filter pressure drop																			
		09		Phase monitor																			
		10		Emergency stop button																			
		11		Water freeze protection controller																			

2 Specifications

2-2 Electrical Specifications			EWAD810 C-PR	EWAD880 C-PR	EWAD960 C-PR	EWADC1 0C-PR	EWADC1 1C-PR	EWADC1 3C-PR	EWADC1 4C-PR	EWADC1 5C-PR	EWADC1 6C-PR	
Compressor	Phase		3~									
	Voltage		V									
	Voltage range	Min.	%									
		Max.	%									
	Maximum running current		A	231	274	333	398	451				
Starting method		Wye-delta										
Compressor 2	Maximum running current		A	231	274	333	398	451				
Power supply	Phase		3~									
	Frequency		Hz									
	Voltage		V									
	Voltage range	Min.	%									
		Max.	%									
Maximum running current		A	618	653	917	964	1,020	1,063	1,076			
Unit	Nominal running current (RLA)	Cooling	A	375	416	461	506	555	614	671	717	764
		Maximum running current	A	509	552	596	660	719	788	858	911	964
	Max unit current for wires sizing		A	555	603	651	712	785	861	937	996	1,054
	Nominal running current (RLA)		A	47			52		57	62		
Fans	Nominal running current (RLA)		A	47			52		57	62		

Notes

- (1) Cooling: entering evaporator water temp. 12°C; leaving evaporator water temp. 7°C; ambient air temp. 35°C; full load operation.
- (2) Sound pressure levels are measured at entering evaporator water temp. 12°C; leaving evaporator water temp. 7°C; ambient air temp. 35°C; full load operation; Standard: ISO3744
- (3) Allowed voltage tolerance ± 10%. Voltage unbalance between phases must be within ± 3%.
- (4) Maximum starting current: starting current of biggest compressor + 75 % of maximum current of the other compressor + fans current for the circuit at 75 %
- (5) Nominal current in cooling mode: entering evaporator water temp. 12°C; leaving evaporator water temp. 7°C; ambient air temp. 35°C. Compressor + fans current.
- (6) Maximum running current is based on max compressor absorbed current in its envelope and max fans absorbed current
- (7) Maximum unit current for wires sizing is based on minimum allowed voltage.
- (8) Maximum current for wires sizing: (compressors full load ampere + fans current) x 1.1

3 Features and advantages

3 - 1 Features and Advantages

Low operating cost

This unit is the result of careful design, aimed to optimizing the energy efficiency of the chillers, with the objective of bringing down operating costs and improving installation profitability, effectiveness and economical management.

A very high efficiency single rotor screw compressor design are used in this application, together with large condenser coil surface area for maximum heat transfer and low discharge pressure, advanced technology condenser fans, a single-pass pure counter-flow shell&tube direct-expansion evaporator with low refrigerant pressure drops.

Low operating sound levels

Very low noise levels both at full load and part load conditions are achieved by the latest compressor design that use a single main rotor with two adjacent rotating composite gaterotors making gas flow velocities and subsequent noise levels among the lowest available. By a unique new fan that moves large volume of air at exceptionally low sound levels and by the virtually vibration-free operation.

Outstanding reliability

The chillers have two or three truly independent refrigerant circuits depending on the size, in order to assure maximum safety for any maintenance, whether planned or not. They are equipped with a rugged compressor design with advanced composite compressor gaterotors material, a proactive control logic and are full factory-run-tested to optimized trouble-free operation.

Infinite capacity control

Cooling capacity control is infinitely variable by means of a single screw asymmetric compressor controlled by microprocessor system. Each unit has infinitely variable capacity control from 100% down to 12.5% (two compressor unit), down to 7% (three compressors units). This modulation allows the compressor capacity to exactly match the building cooling load without any leaving evaporator water temperature fluctuation. This chilled water temperature fluctuation is avoided only with a stepless control.

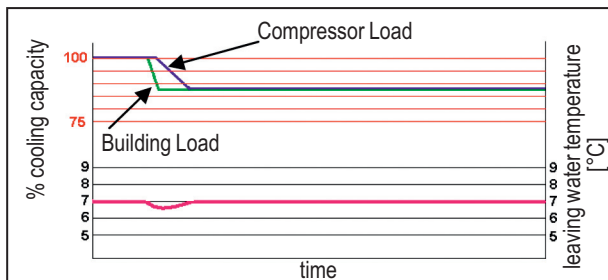

ELWT fluctuation with stepless capacity control

With a compressor load step control in fact, the compressor capacity, at partial loads, will be too high or too low compared to the building cooling load. The result is an increase in chiller energy costs, particularly at the part-load conditions at which the chiller operates most of the time.

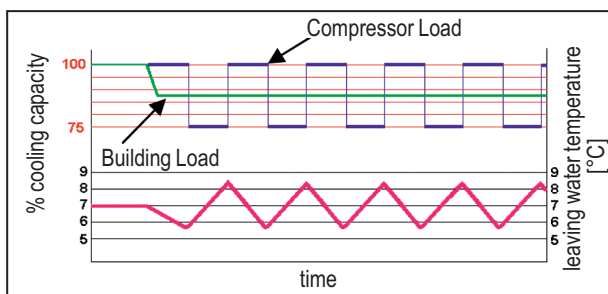

ELWT fluctuation with steps capacity control (4 steps)

Units with stepless regulation offer benefits that the units with step regulation are unable to match. The ability to follow the system energy demand at any time and the possibility to provide steady outlet water temperature without deviations from the set-point, are the two points that allow you to understand how the optimum operating conditions of a system can be met only through the use of a unit with step-less regulation.

Superior control logic

The new MicroTech III controller provides an easy to use control environmental. The control logic is designed to provide maximum efficiency, to continue operation in unusual operating conditions and to provide a history of unit operation. One of the greatest benefits is the easy interface with LonWorks, Bacnet, Ethernet TCP/IP or Modbus communications.

3 Features and advantages

3 - 1 Features and Advantages

3

Code requirements – Safety and observant of laws/directives

Units are designed and manufactured in accordance with applicable selections of the following:

Construction of pressure vessel	97/23/EC (PED)
Machinery Directive	2006/42/EC
Low Voltage	2006/95/EC
Electromagnetic Compatibility	2004/108/EC
Electrical & Safety codes	EN 60204–1 / EN 60335-2-40
Manufacturing Quality Stds	UNI – EN ISO 9001:2004

Certifications

Units are CE marked, complying with European directives in force, concerning manufacturing and safety. On request units can be produced complying with laws in force in non European countries (ASME, GOST, etc.), and with other applications, such as naval (RINA, etc.).

Versions

Three different Efficiency Versions available:

S: Standard Efficiency

15 sizes to cover a range from 647 up to 1922 kW with an EER up to 2.99 and an ESEER up to 4.08 (data referred to Standard Noise)

X: High Efficiency

17 sizes to cover a range from 756 up to 2008 kW with an EER up to 3.29 and an ESEER up to 4.33 (data referred to Standard Noise)

P: Premium Efficiency

9 sizes to cover a range from 821 up to 1562 kW with an EER up to 3.64 and an ESEER up to 4.53 (data referred to Standard Noise)

The EER (Energy Efficiency Ratio) is the ratio of the Cooling Capacity to the Power Input of the unit. The Power Input includes: the power input for operation of the compressor, the power input of all control and safety devices, the power input for fans.

The ESEER (European Seasonal Energy Efficiency Ratio) is a weighed formula enabling to take into account the variation of EER with the load rate and the variation of air inlet condenser temperature.

$$ESEER = A \times EER_{100\%} + B \times EER_{75\%} + C \times EER_{50\%} + D \times EER_{25\%}$$

	A	B	C	D
Coefficient	0.03 (3%)	0.33 (33%)	0.41 (41%)	0.23 (23%)
Air inlet condenser temperature	35°C	30°C	25°C	20°C

Sound Configuration

Standard, low and reduced sound configurations available as follows:

SS: Standard Noise

Condenser fan rotating at 900 rpm, rubber antivibration under compressor

SL: Low Noise

Condenser fan rotating at 900 rpm, rubber antivibration under compressor, compressor sound enclosure.

SR: Reduced Noise

Condenser fan rotating at 700 rpm, rubber antivibration under compressor, compressor sound enclosure.

4 General Characteristics

4 - 1 General characteristics

Cabinet and structure The cabinet is made of galvanized steel sheet and painted to provide a high resistance to corrosion. Colour Ivory White (Munsell code 5Y7.5/1) (\pm RAL7044). The base frame has an eye-hook to lift the unit with ropes for an easy installation. The weight is uniformly distributed along the profiles of the base and this facilitates the arrangement of the unit.

Compressor (Asymmetric Single Screw) The compressor is semi-hermetic, single-screw type with gate-rotor made with the latest high-strength fibre reinforced star material. The compressor has an asymmetric slide regulation managed by the unit controller for infinitely modulating capacity from 100% to 25%. An integrated high efficiency oil separator maximizes the oil separation and standard start is Wye-Delta (Y- Δ) type.

Refrigerant The compressors have been designed to operate with R-134a, ecological refrigerant with zero ODP (Ozone Depletion Potential) and very low GWP (Global Warming Potential), resulting in low TEWI (Total Equivalent Warming Impact).

Evaporator (Shell&Tube) The unit is equipped with a direct expansion shell&tube evaporator with refrigerant evaporating inside the tubes and water flowing outside. The tubes are enhanced for maximum heat transfer and rolled into steel tube sheet and sealed.

The evaporators are single-pass on both the refrigerant and water sides for pure counter-flow heat exchange and low refrigerant pressure drops. Both attributes contribute to the heat exchanger effectiveness and total unit's outstanding efficiency. The water side is designed for 10 bar of maximum operating pressure and is provided with vents and drain.

The external shell is covered with a 20mm closed cell insulation material and the evaporator water connections are provided with victaulic kit (as standard). Each evaporator has 2 or 3 circuits, one for each compressor and is manufactured in accordance to 97/23/EC directive (PED).

Condenser The condenser is manufactured with internally enhanced seamless copper tubes arranged in a staggered row pattern and mechanically expanded into lanced and rippled aluminum condenser fins with full fin collars. An integral sub-cooler circuit provides sub-cooling to effectively eliminate liquid flashing and increase cooling capacity without increasing the power input.

Heat Recovery Exchanger The unit is equipped with a plate to plate type heat exchanger for each circuit made of stainless steel brazed plates and manufactured in accordance to PED approval.

Condenser fans (\varnothing 800) The condenser fans are propeller type with high efficiency design blades to maximize performances. The material of the blades is glass reinforced resin and each fan is protected by a guard. Fan motors are protected by circuit breakers (installed inside the electrical panel as a standard) and are IP54.

Electronic expansion valve The unit is equipped with the most advanced electronic expansion valves to achieve precise control of refrigerant mass flow. As today's system requires improved energy efficiency, tighter temperature control, wider range of operating conditions and incorporate features like remote monitoring and diagnostics, the application of electronic expansion valves becomes mandatory.

Electronic expansion valves possess unique features: short opening and closing time, high resolution, positive shut-off function to eliminate use of additional solenoid valve, continuous modulation of mass flow without stress in the refrigerant circuit and corrosion resistance stainless steel body.

Electronic expansion valves are typically working with lower Δ P between high and low pressure side, than a thermostatic expansion valve. The electronic expansion valve allows the system to work with low condenser pressure (winter time) without any refrigerant flow problems and with a perfect chilled water leaving temperature control.

Refrigerant circuit Each unit has 2 or 3 independent refrigerant circuits and each one includes:

- Compressor with integrated oil separator
- Refrigerant
- Evaporator
- Air Cooled Condenser
- Electronic expansion valve
- Discharge line shut off valve
- Liquid line shut off valve
- Sight glass with moisture indicator
- Filter drier
- Charging valves
- High pressure switch
- High pressure transducers
- Low pressure transducers
- Oil pressure transducer

4 General Characteristics

4 - 1 General characteristics

4

Electrical control panel Power and control are located in the main panel that is manufactured to ensure protection against all weather conditions. The electrical panel is IP54 and (when opening the doors) internally protected with plexiglas panel against possible accidental contact with electrical components (IP20). The main panel is fitted with a main switch interlocked door. Power Section The power section includes compressors and fans protection devices, compressors and fans starters and control circuit power supply.

MicroTech III controller MicroTech III controller is installed as standard; it can be used to modify unit set-points and check control parameters. A built-in display shows chiller operating status plus temperatures and pressures of water, refrigerant and air, programmable values, set-points. A sophisticated software with predictive logic, selects the most energy efficient combination of compressors, EEXV and condenser fans to keep stable operating conditions to maximise chiller energy efficiency and reliability.

MicroTech III is able to protect critical components based on external signs from its system (such as motor temperatures, refrigerant gas and oil pressures, correct phase sequence, pressure switches and evaporator). The input coming from the high pressure switch cuts all digital output from the controller in less than 50ms, this is an additional security for the equipment.

Fast program cycle (200ms) for a precise monitoring of the system. Floating point calculations supported for increased accuracy in Pressure / Temperature conversions.

Control section - main features

- Management of the compressor stepless capacity and fans modulation.
- Chiller enabled to work in partial failure condition.
- Full routine operation at condition of:
 - high ambient temperature value
 - high thermal load
 - high evaporator entering water temperature (start-up)
- Display of evaporator entering/leaving water temperature.
- Display of Outdoor Ambient Temperature.
- Display of condensing-evaporating temperature and pressure, suction and discharge superheat for each circuit.
- Leaving water evaporator temperature regulation (temperature tolerance = 0,1°C).
- Compressor and evaporator pumps hours counter.
- Display of Status Safety Devices.
- Number of starts and compressor working hours.
- Optimized management of compressor load.
- Fan management according to condensing pressure.
- Re-start in case of power failure (automatic / manual).
- Soft Load (optimized management of the compressor load during the start-up).
- Start at high evaporator water temperature.
- Return Reset (Set Point Reset based on return water temperature).
- OAT (Outside Ambient temperature) Reset.
- Set point Reset (optional).
- Application and system upgrade with commercial SD cards.
- Ethernet port for remote or local servicing using standard web browsers.
- Two different sets of default parameters could be stored for easy restore.

Safety device / logic for each refrigerant circuit

- High pressure (pressure switch).
- High pressure (transducer).
- Low pressure (transducer).
- Fans circuit breaker.
- High compressor discharge temperature.
- High motor winding temperature.
- Phase Monitor.
- Low pressure ratio.
- High oil pressure drop.
- Low oil pressure.
- No pressure change at start.

System security

- Phase monitor.
- Low Ambient temperature lock-out.
- Freeze protection.

Regulation type Proportional + integral + derivative regulation on the evaporator leaving water output probe.

GNC_1a-2a-3a-4a_Rev.01_2a

4 General Characteristics

4 - 1 General characteristics

MicroTech III MicroTech III built-in terminal has the following features.

- 164x44 dots liquid crystal display with white back lighting. Supports Unicode fonts for multi-lingual.
- Key-pad consisting of 3 keys.
- Push'n'Roll control for an increased usability.
- Memory to protect the data.
- General faults alarm relays.
- Password access to modify the setting.
- Application security to prevent application tampering or hardware usability with third party applications.
- Service report displaying all running hours and general conditions.
- Alarm history memory to allow an easy fault analysis.

Supervising systems (on request)

MicroTech III remote control MicroTech III is able to communicate to BMS (Building Management System) based on the most common protocols as:

- ModbusRTU
- LonWorks, now also based on the international 8040 Standard Chiller Profile and LonMark Technology.
- BacNet BTP certified over IP and MS/TP (class 4) (Native).
- Ethernet TCP/IP.

Standard Options (supplied on basic unit)

Wye-Delta compressor starter (Y-D) - For low inrush current and reduced starting torque

Double setpoint - Dual leaving water temperature setpoints.

Phase monitor - The phase monitor controls that phases sequence is correct and controls phase loss.

Evaporator victaulic kit - Hydraulic joint with gasket for an easy and quick water connection.

20mm evaporator insulation - The external shell is covered with a 20mm closed cell insulation material.

Evaporator electric heater - Electric heater (controlled by a thermostat) to protect the evaporator from freezing down to -28°C ambient temperature, providing the power supply is on.

Electronic expansion valve

Discharge line shut-off valve - Installed on the discharge port of the compressor to facilitate maintenance operation.

Ambient outside temperature sensor and setpoint reset

Hour run meter

General fault contactor

Setpoint reset, Demand limit and Alarm from external device - (Set-point reset): The leaving water temperature set-point can be overwritten with the following options: 4-20mA from external source (by user); outside ambient temperature; evaporator water temperature Δt . - (Demand limit): User can limit the load of the unit by 4-20mA signal or by network system. - (Alarm from external device): Microprocessor is able to receive an alarm signal from an external device (eg. pump, etc...). User can decide if this alarm signal will stop or not the unit.

Fans circuit breakers - Safety device against motor overloading and short circuit

Main switch interlock door

Emergency stop

Options (on request)

MECHANICAL

Total heat recovery - Produced with plate to plate or Shell&Tube heat exchangers to produce hot water.

Partial heat recovery - Produced with plate to plate heat exchangers to produce hot water.

Brine version - Allows the unit to operate down to -8°C leaving liquid temperature (antifreeze required).

Evaporator flange kit

Condenser coil guards

Evaporator area guards

Cu-Cu condenser coil - To give better protection against corrosion by aggressive environments.

Cu-Cu-Sn condenser coil - To give better protection against corrosion in aggressive environments and by salty air.

Alucoat fins coil - Fins are protected by a special acrylic paint with a high resistance to corrosion.

Suction line shut-off valve - Installed on the suction port of the compressor to facilitate maintenance operation.

High pressure side manometers

Low pressure side manometers

One centrifugal pump (low lift) - Hydronic kit consists of: single direct driven centrifugal pump, water filling system with pressure gauge, safety valve, drain valve. The motor pump is protected by a circuit breaker installed in control panel. The kit is assembled and wired to the control panel. The pipe and pump are protected from freezing with an additional electrical heater.

4 General Characteristics

4 - 1 General characteristics

4

One centrifugal pump (high lift) Hydronic kit consists of: single direct driven centrifugal pump, water filling system with pressure gauge, safety valve, drain valve. The motor pump is protected by a circuit breaker installed in control panel. The kit is assembled and wired to the control panel. The pipe and pump are protected from freezing with an additional electrical heater.

Two centrifugal pump (low lift) - Hydronic kit consists of: twin direct driven centrifugal pumps, water filling system with pressure gauge, safety valve, drain valve. The motor pump is protected by a circuit breaker installed in control panel. The kit is assembled and wired to the control panel. The pipe and pumps are protected from freezing with an additional electrical heater.

Two centrifugal pump (high lift) Hydronic kit consists of: twin direct driven centrifugal pumps, water filling system with pressure gauge, safety valve, drain valve. The motor pump is protected by a circuit breaker installed in control panel. The kit is assembled and wired to the control panel. The pipe and pumps are protected from freezing with an additional electrical heater.

Double pressure relief valve with diverter

Evaporator right water connections

ELECTRICAL / CONTROL

Soft starter - Electronic starting device to reduce the mechanical stress during compressor start-up

Compressor thermal overload relays - Safety devices against compressor motor overloading. This device together with internal motor protection (standard) guarantee the best safety system for compressor motor.

Under / Over voltage control - This device control the voltage value of power supply and stop the chiller if the value exceeds the allowed operating limits.

Energy meter - Device installed inside the control box showing ampere and volt values

Capacitors for power factor correction - To increase the operating power factor of the unit at nominal operating conditions. The capacitors are "dry" self-regenerating type with over pressure disconnecting safety device insulated with a no toxic dielectric mix with no PCB or PCT.

Current limit - To limit maximum absorbed current of the unit whenever is required

Speedtrol (fan speed control device - ON/OFF - up to -18°C) - Continuous fan speed modulation on the first fan of each circuit. It allows the unit working with air temperature down to -18°C.

Evaporator flow switch - Supplied separately to be wired and installed on the evaporator water piping (by the customer).
Compressors circuit breakers

Fans speed regulation (+ fan silent mode) - To control the fan speed revolution for smooth operating control of the unit. This option improves the sound level of the unit during low ambient temperature operation.

Ground fault relay - To shut down the entire unit if a ground fault condition is detected.

Rapid restart - It allows the unit to start as fast as 30 seconds after power is restored (in case of power failure).

INSTALLATION

Rubber anti vibration mounts - Supplied separately, these are positioned under the base of the unit during installation. Ideal to reduce the vibrations when the unit is floor mounted.

Spring anti vibration mounts - Supplied separately, these are positioned under the base of the unit during installation. Ideal for dampening vibrations for installation on roofs and metallic structures.

OTHER

Container Kit

Witness test

Acoustic test

Refrigerant recovery unit - This option allows to stock refrigerant charge of 1 circuit for maintenance operation. Liquid receiver includes in/out shut-off valve and relief valve.

Transport kit

5 Nomenclature

5 - 1 Nomenclature

Nomenclature

Name	EWA	D	200	C	-	S	S
Digits	1 2 3	4	5 6 7	8	9	10	11

Machine type
 EWA = Air-cooled chiller, cooling only
 EWY = Air-cooled chiller, heat pump
 EWL = Remote condenser chiller
 ERA = Air cooled condensing unit
 EWW = Water-cooled chiller, cooling only
 EWC = Air-cooled chiller, cooling only with centrifugal fan
 EWR = Air-cooled chiller, cooling only with heat recovery

Refrigerant
 D = R-134a
 P = R-407c
 Q = R-410a

Capacity class in kW (Cooling)
 Approximation of cooling capacity

Model series
 Letter A, B,... : major modification

Inverter
 - = Non-inverter
 Z = Inverter

Efficiency level
 S = Standard efficiency
 X = High efficiency
 P = Premium efficiency
 H = High ambient

Sound level
 L = Low noise
 S = Standard noise
 R = Reduced noise
 X = Extra low noise
 C = Cabinet

6 Options

6 - 1 Water Pump Kit - Technical Information

6

Water Pump Kit - Discharge Head

Single Pump (2 poles) - Discharge Head

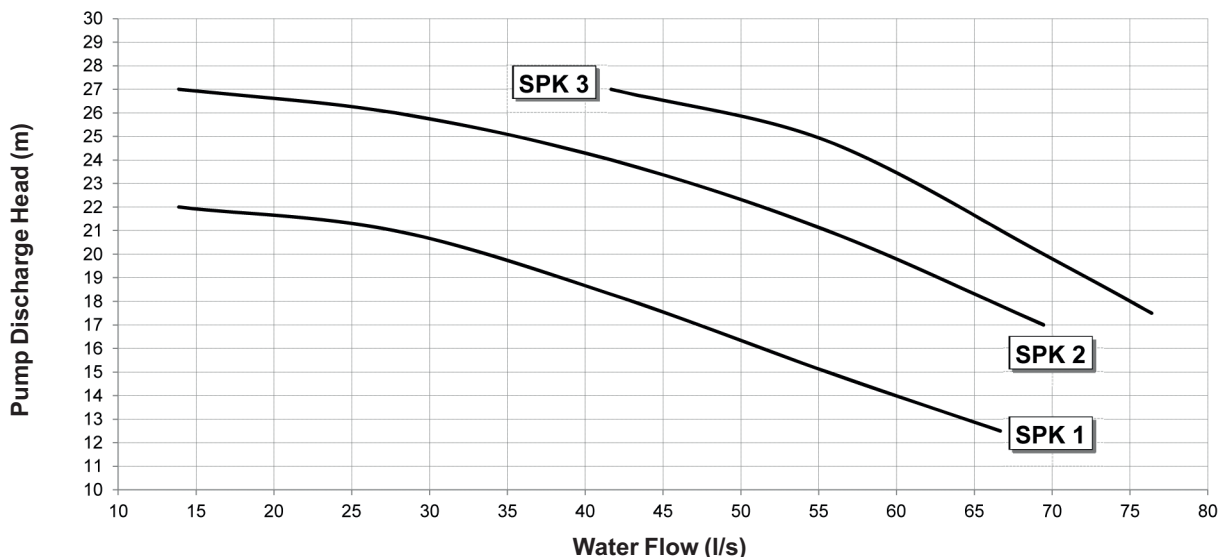

Note

- the above curves are referred to the discharge head of the pump only
- when selecting the pump you have to consider the installation and evaporator pressure drops
- when using mixture of water and glycol please contact the factory as above specification can change

Twin Pump (2 poles) - Discharge Head

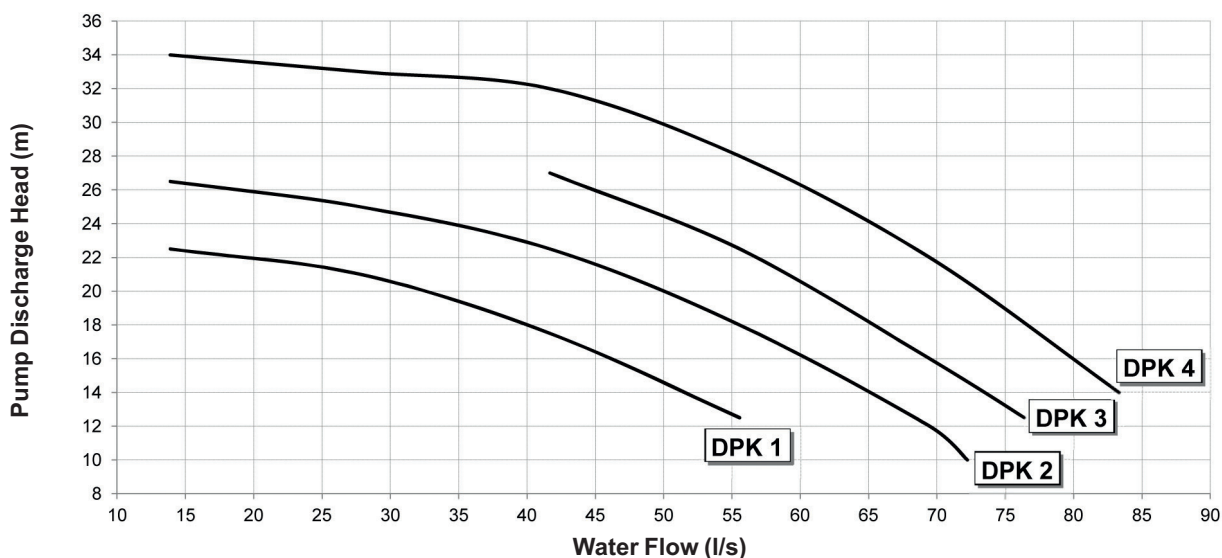

NOTES

- the above curves are referred to the discharge head of the pump only
- when selecting the pump you have to consider the installation and evaporator pressure drops
- when using mixture of water and glycol please contact the factory as above specification can change

6 Options

6 - 1 Water Pump Kit - Technical Information

		Pump Motor Power (kW)	Pump Motor Current (A)	Power supply (V-ph-Hz)	PN	Motor Protection	Insulation (Class)	Working Temp. (°C)
Single Pump	SPK 1	11,0	20,0	400V-3ph-50hz	16	IP55	class F	-20 +140
	SPK 2	15,0	26,5	400V-3ph-50hz	16	IP55	class F	-20 +140
	SPK 3	18,5	32,5	400V-3ph-50hz	16	IP55	class F	-20 +140
Double Pump	DPK 1	11,0	20,0	400V-3ph-50hz	16	IP55	class F	-20 +140
	DPK 2	15,0	26,5	400V-3ph-50hz	16	IP55	class F	-20 +140
	DPK 3	18,5	32,5	400V-3ph-50hz	16	IP55	class F	-20 +140
	DPK 4	22,0	39,0	400V-3ph-50hz	16	IP55	class F	-20 +140

NOTE

- When using mixture of water and glycol please contact the factory as above specification can change

WPKTI_1a-2a-3a_Rev.03_3a

6 Options

6 - 2 Water Pump Kit - Combination Matrix

6

Version	Size	Version	Size	Single Pump			Double Pump			
				SPK 1	SPK 2	SPK 3	DPK 1	DPK 2	DPK 3	DPK 4
EWAD-C-SS EWAD-C-SL	650	EWAD-C-SR	620	X	X		X	X		
	740		720	X	X		X	X		
	830		790	X	X		X	X		
	910		880	X	X		X	X		
	970		920	X	X	X	X	X		
	C11		C10	X	X	X	X	X		
	C12		C11	X	X	X	X	X	X	X
	C13		C12		X	X			X	X
	H14		H14			X				X
EWAD-C-XS EWAD-C-XL	760	EWAD-C-XR	740	X	X		X	X		
	830		810	X	X		X	X		
	890		870	X	X		X	X		
	990		970	X	X	X	X	X	X	X
	C10		C10	X	X	X	X	X	X	X
	C11		C11	X	X	X		X	X	X
	C12		C12	X	X	X		X	X	X
	C13		C13	X	X	X		X	X	X
	H14		H14			X				X
	H15		H15			X				X
EWAD-C-PS EWAD-C-PL	820	EWAD-C-PR	810	X	X		X	X		
	890		880	X	X		X	X		
	980		960	X	X	X	X	X		
	C11		C10	X	X	X	X	X	X	X
	C12		C11	X	X	X		X	X	X
	C13		C13	X	X	X		X	X	X
	C14		C14		X	X		X	X	X
	C15		C15			X				X
	C16		C16							

WPKCM_1a-2a-3a_Rev.03_2a

8 Dimensional drawings

8 - 1 Dimensional Drawings

EWAD-C- (2 circuits)

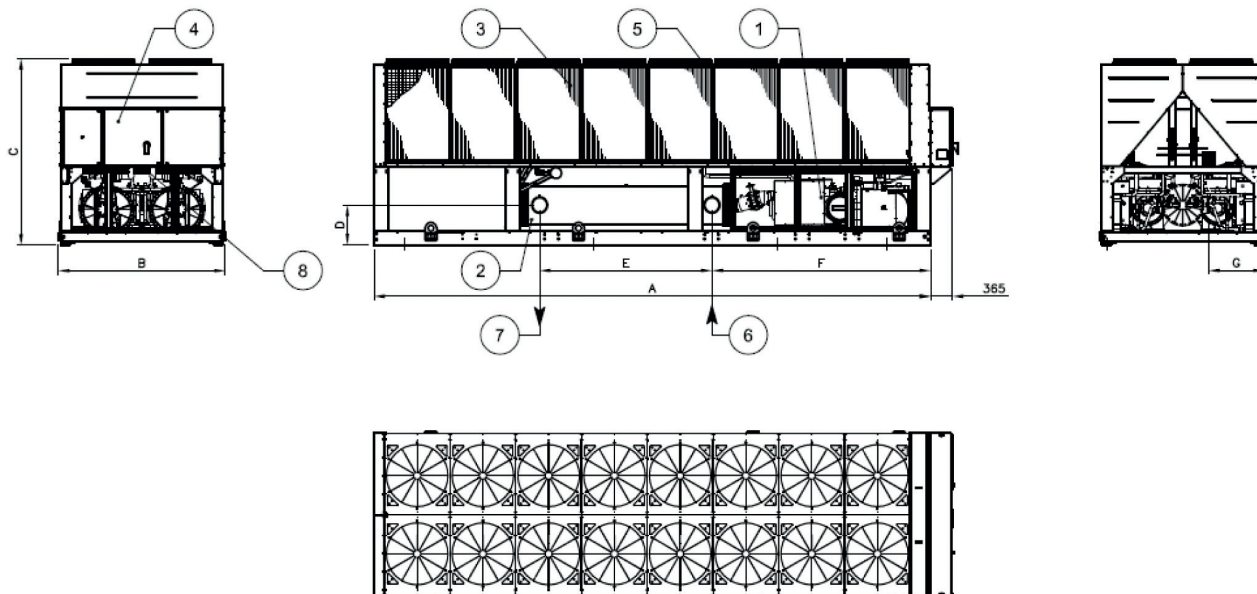

Drawing is for illustration only. Please refer to the table below for unit dimensions.

EWAD~C-		Dimensions (mm)							Fans
Size	Size	A	B	C	D	E	F	G	
EWAD650+830C-SS/SL	EWAD620+720C-SR	6185	2285	2540	450	2412	435	810	Nr 10
EWAD910+970C-SS/SL	EWAD880+920C-SR	6185	2285	2540	450	2412	435	810	Nr 12
EWADC11C-SS/SL	EWADC10C-SR	7085	2285	2540	1350	2412	435	810	Nr 14
EWADC12C-SS/SL	EWADC11C-SR	7985	2285	2540	2250	2412	435	810	Nr 16
EWADC13+H14C-SS/SL	EWADC12+H14C-SR	8885	2285	2540	3170	2360	540	760	Nr 18
EWAD760C-XS/XL	EWAD740C-XR	6185	2285	2540	470	2412	435	810	Nr 12
EWAD830+890C-XS/XL	EWAD810+870C-XR	7085	2285	2540	1370	2412	435	810	Nr 14
EWAD990+C10C-XS/XL	EWAD970+C10C-XR	7985	2285	2540	2270	2360	540	760	Nr 16
EWADC11+C13C-XS/XL	EWADC11+C13C-XR	9785	2285	2540	4070	2360	540	760	Nr 20
EWADH14+H15C-XS/XL/XR		9785	2285	2285	2920	3440	540	685	Nr 20
EWAD820+890C-PS/PL	EWAD810+880C-PR	8885	2285	2540	2020	3510	540	760	Nr 18
EWAD980C-PS/PL	EWAD960C-PR	8885	2285	2540	2020	3440	540	685	Nr 18
EWADC11+C12C-PS/PL	EWADC10+C11C-PR	9785	2285	2540	2920	3440	540	685	Nr 20
EWADC13C-PS/PL	EWADC13C-PR	11085	2285	2540	4205	3440	540	685	Nr 22
EWADC14C-PS/PL	EWADC14C-PR	11985	2285	2540	5105	3440	540	685	Nr 24
EWADC15+C16C-PS/PL/PR		11985	2285	2285	5130	3440	540	685	Nr 24

LEGEND

1. Compressor
2. Evaporator
3. Condenser coil
4. Electrical panel
5. Fan
6. Evaporator Water inlet
7. Evaporator Water outlet
8. Slot for power and control connection

9 Sound data

9 - 1 Sound Power Spectrum

SOUND LEVELS EWAD~C-PS

MODEL	Sound pressure level at 1 m from the unit (rif. 2 x 10 ⁻⁵ Pa)									Power dB(A)
	63 Hz	125 Hz	250 Hz	500 Hz	1000 Hz	2000 Hz	4000 Hz	8000 Hz	dB(A)	
820	74,4	76,5	79,3	78,5	74,4	69,9	60,3	51,2	79,5	101,0
890	74,4	76,5	79,3	78,5	74,4	69,9	60,3	51,2	79,5	101,0
980	74,4	76,5	79,3	78,5	74,4	69,9	60,3	51,2	79,5	101,0
C11	74,9	77,0	79,8	79,0	74,9	70,4	60,8	51,7	80,0	101,8
C12	75,4	77,5	80,3	79,5	75,4	70,9	61,3	52,2	80,5	102,3
C13	75,3	77,4	80,2	79,4	75,3	70,8	61,2	52,1	80,4	102,6
C14	75,4	77,5	80,3	79,5	75,4	70,9	61,3	52,2	80,5	102,9
C15	75,7	77,8	80,6	79,8	75,7	71,2	61,6	52,5	80,8	103,2
C16	76,0	78,1	80,9	80,1	76,0	71,5	61,9	52,8	81,1	103,5

EWAD~C-PL

MODEL	Sound pressure level at 1 m from the unit (rif. 2 x 10 ⁻⁵ Pa)									Power dB(A)
	63 Hz	125 Hz	250 Hz	500 Hz	1000 Hz	2000 Hz	4000 Hz	8000 Hz	dB(A)	
820	71,8	73,9	76,7	75,9	71,8	67,3	57,7	48,6	76,9	98,4
890	71,8	73,9	76,7	75,9	71,8	67,3	57,7	48,6	76,9	98,4
980	71,8	73,9	76,7	75,9	71,8	67,3	57,7	48,6	76,9	98,4
C11	71,9	74,0	76,8	76,0	71,9	67,4	57,8	48,7	77,0	98,8
C12	72,0	74,1	76,9	76,1	72,0	67,5	57,9	48,8	77,1	99,9
C13	72,0	74,1	76,9	76,1	72,0	67,5	57,9	48,8	77,1	99,3
C14	72,1	74,2	77,0	76,2	72,1	67,6	58,0	48,9	77,2	99,6
C15	72,4	74,5	77,3	76,5	72,4	67,9	58,3	49,2	77,5	99,9
C16	72,7	74,8	77,6	76,8	72,7	68,2	58,6	49,5	77,8	100,2

EWAD~C-PR

MODEL	Sound pressure level at 1 m from the unit (rif. 2 x 10 ⁻⁵ Pa)									Power dB(A)
	63 Hz	125 Hz	250 Hz	500 Hz	1000 Hz	2000 Hz	4000 Hz	8000 Hz	dB(A)	
810	67,8	61,0	68,1	73,3	60,7	57,1	48,8	36,2	71,2	92,7
880	67,8	61,0	68,1	73,3	60,7	57,1	48,8	36,2	71,2	92,7
960	67,8	61,0	68,1	73,3	60,7	57,1	48,8	36,2	71,2	92,7
C10	68,3	61,5	68,6	73,8	61,2	57,6	49,3	36,7	71,7	93,4
C11	68,6	61,8	68,9	74,1	61,5	57,9	49,6	37,0	72,0	93,8
C13	68,6	61,8	68,9	74,1	61,5	57,9	49,6	37,0	72,0	94,1
C14	68,6	61,8	68,9	74,1	61,5	57,9	49,6	37,0	72,0	94,4
C15	68,9	62,1	69,2	74,4	61,8	58,2	49,9	37,3	72,3	94,7
C16	69,2	62,4	69,5	74,7	62,1	58,5	50,2	37,6	72,6	95,0

NOTE

Reduction to be applied to standard, low and reduced sound configuration.

9 Sound data

9 - 1 Sound Power Spectrum

Sound pressure level correction factor for different distances

EWAD~C-SS / EWAD~C-SL / EWAD~C-SR

Unit size			Distance						
EWAD~C-SS	EWAD~C-SL	EWAD~C-SR	1m	5m	10m	15m	20m	25m	50m
650	650	620	0,0	-7,1	-11,6	-14,6	-16,8	-18,6	-24,2
740	740	720	0,0	-7,1	-11,6	-14,6	-16,8	-18,6	-24,2
830	830	790	0,0	-7,1	-11,6	-14,6	-16,8	-18,6	-24,2
910	910	880	0,0	-7,1	-11,6	-14,6	-16,8	-18,6	-24,2
970	970	920	0,0	-7,1	-11,6	-14,6	-16,8	-18,6	-24,2
C11	C11	C10	0,0	-6,9	-11,4	-14,3	-16,5	-18,3	-23,9
C12	C12	C11	0,0	-6,7	-11,2	-14,1	-16,3	-18,0	-23,6
C13	C13	C12	0,0	-6,6	-11,0	-13,9	-16,0	-17,8	-23,4
H14	H14	H14	0,0	-6,6	-11,0	-13,9	-16,0	-17,8	-23,4
C15	C15	C14	0,0	-6,4	-10,7	-13,6	-15,7	-17,4	-17,4
C16	C16	C15	0,0	-6,3	-10,5	-13,4	-15,5	-17,2	-17,2
C17	C17	C16	0,0	-6,3	-10,5	-13,4	-15,5	-17,2	-17,2
C18	C18	C17	0,0	-6,3	-10,5	-13,4	-15,5	-17,2	-22,8
C19	C19	C18	0,0	-6,2	-10,4	-13,2	-15,3	-17,0	-22,5
C20	C20	C19	0,0	-6,2	-10,4	-13,2	-15,3	-17,0	-22,5

EWAD~C-XS / EWAD~C-XL / EWAD~C-XR

Unit size			Distance						
EWAD~C-XS	EWAD~C-XL	EWAD~C-XR	1m	5m	10m	15m	20m	25m	50m
760	760	740	0,0	-7,1	-11,6	-14,6	-16,8	-18,6	-24,2
830	830	810	0,0	-6,9	-11,4	-14,3	-16,5	-18,3	-23,9
890	890	870	0,0	-6,9	-11,4	-14,3	-16,5	-18,3	-23,9
990	990	970	0,0	-6,7	-11,2	-14,1	-16,3	-18,0	-23,6
C10	C10	C10	0,0	-6,7	-11,2	-14,1	-16,3	-18,0	-23,6
C11	C11	C11	0,0	-6,5	-10,8	-13,7	-15,8	-17,5	-23,1
C12	C12	C12	0,0	-6,5	-10,8	-13,7	-15,8	-17,5	-23,1
C13	C13	C13	0,0	-6,5	-10,8	-13,7	-15,8	-17,5	-23,1
H14	H14	H14	0,0	-6,5	-10,8	-13,7	-15,8	-17,5	-23,1
H15	H15	H15	0,0	-6,5	-10,8	-13,7	-15,8	-17,5	-23,1
C16	C16	C16	0,0	-6,2	-10,4	-13,2	-15,3	-17,0	-22,5
C17	C17	C17	0,0	-6,1	-10,3	-13,0	-15,1	-16,8	-22,3
C18	C18	C18	0,0	-6,0	-10,1	-12,9	-15,0	-16,7	-22,1
C19	C19	C19	0,0	-5,9	-10	-12,7	-14,8	-16,5	-22,0
C20	C20	C20	0,0	-5,9	-10,0	-12,7	-14,8	-16,5	-22,0
C21	C21	C21	0,0	-5,9	-10	-12,7	-14,8	-16,5	-22,0
C22	C22	C22	0,0	-5,9	-10	-12,7	-14,8	-16,5	-22,0

EWAD~C-PS / EWAD~C-PL / EWAD~C-PR

Unit size			Distance						
EWAD~C-PS	EWAD~C-PL	EWAD~C-PR	1m	5m	10m	15m	20m	25m	50m
820	820	810	0,0	-6,6	-11,0	-13,9	-16,0	-17,8	-23,4
890	890	880	0,0	-6,6	-11,0	-13,9	-16,0	-17,8	-23,4
980	980	960	0,0	-6,6	-11,0	-13,9	-16,0	-17,8	-23,4
C11	C11	C10	0,0	-6,5	-10,8	-13,7	-15,8	-17,5	-23,1
C12	C12	C11	0,0	-6,5	-10,8	-13,7	-15,8	-17,5	-23,1
C13	C13	C13	0,0	-6,3	-10,5	-13,4	-15,5	-17,2	-22,8
C14	C14	C14	0,0	-6,2	-10,4	-13,2	-15,3	-17,0	-22,5
C15	C15	C15	0,0	-6,2	-10,4	-13,2	-15,3	-17,0	-22,5
C16	C16	C16	0,0	-6,2	-10,4	-13,2	-15,3	-17,0	-22,5

NOTE

Reduction to be applied to standard, low and reduced sound configuration.

10 Installation

10 - 1 Installation Method

Warning Installation and maintenance of the unit must to be performed only by qualified personnel who have knowledge with local codes and regulations, and experience with this type of equipment. Must be avoided the unit installation in places that could be considered dangerous for all the maintenance operations.

Handling Care should be taken to avoid rough handling or shock due to dropping the unit. Do not push or pull the unit from anything other than the base frame. Never allow the unit to fall during unloading or moving as this may result in serious damage. To lift the unit, rings are provided in the base frame of the unit. Spreader bar and cables should be arranged to prevent damage to the condenser coil or unit cabinet.

Location The units are produced for outside installation on roofs, floors or below ground level on condition that the area is free from obstacles for the passage of the condenser air. The unit should be positioned on solid foundations and perfectly level; in the case of installation on roofs or floors, it may be advisable to arrange the use of suitable weight distribution beams. When the units are installed on the ground, a concrete base at least 250 mm wider and longer than the unit's footprint should be laid. Furthermore, this base should withstand the unit weight mentioned in the technical data table.

Space requirements The units are air-cooled, then it is important to respect the minimum distances which guarantee the best ventilation of the condenser coils. Limitations of space reducing the air flow could cause significant reductions in cooling capacity and an increase in electricity consumption.

To determinate unit placement, careful consideration must be given to assure a sufficient air flow across the condenser heat transfer surface. Two conditions must be avoided to achieve the best performance: warm air recirculation and coil starvation. Both these conditions cause an increase of condensing pressures that results in reductions in unit efficiency and capacity.

Moreover the unique microprocessor has the ability to calculate the operating environment of the air cooled chiller and the capacity to optimize its performance staying on-line during abnormal conditions.

Each side of the unit must be accessible after installation for periodic service. Fig.1 shows you minimum recommended clearance requirements. Vertical condenser air discharge must be unobstructed because the unit would have its capacity and efficiency significantly reduced.

If the units are positioned in places surrounded by walls or obstacles of the same height as the units, the units should be at least 2500 mm from obstacles (Fig.2). In the event the obstacles are higher than the units, the units should be at least 3000 mm from the obstacle (Fig.3). Units installed closer than the minimum recommended distance to a wall or other vertical riser may experience a combination of coil starvation and warm air recirculation, thus causing reduction in unit capacity and efficiency reductions. The microprocessor control is proactive in response "of design condition". In the case of single or compounded influences restricting airflow to the unit, the microprocessor will act to keep the compressor(s) running (at reduced capacity) rather than allowing a shut-off on high discharge pressure.

When two or more units are positioned side by side it is recommended that the condenser coils are at least 3600 mm distance from one another (Fig.4); strong wind could be the cause of air warm recirculation.

For other installation solutions, consult our technicians.

The above recommended information are representative of general installation. A specific evaluation should be done by contractor depending on the case.

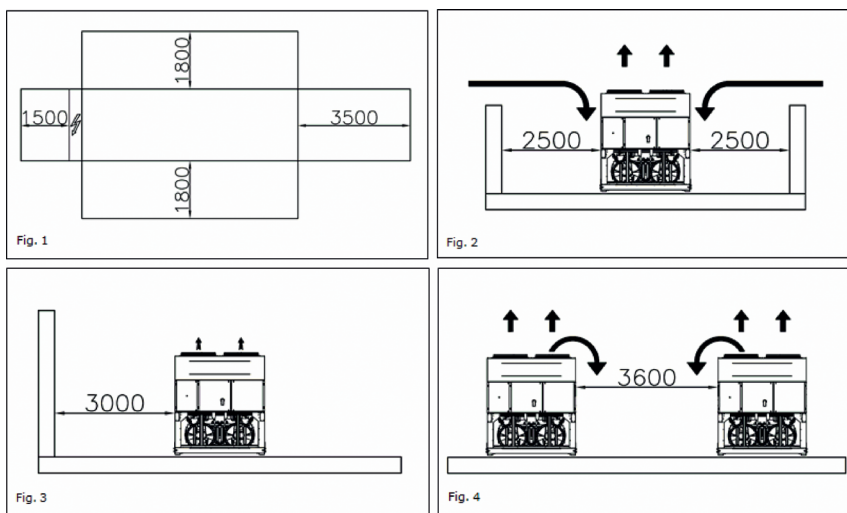

Acoustic protection When noise level must meet special requirements, it is necessary to pay the maximum attention to ensure the perfect insulation of the unit from the support base by applying appropriate vibration-dampening devices on the unit, on the water pipes and on the electrical connections.

Storage The environment conditions have to be in the following limits:

- Minimum ambient temperature: -20°C
- Maximum ambient temperature: +57°C
- Maximum R.H.: 95% not condensing

11 Operation range

11 - 1 Operation Range

11

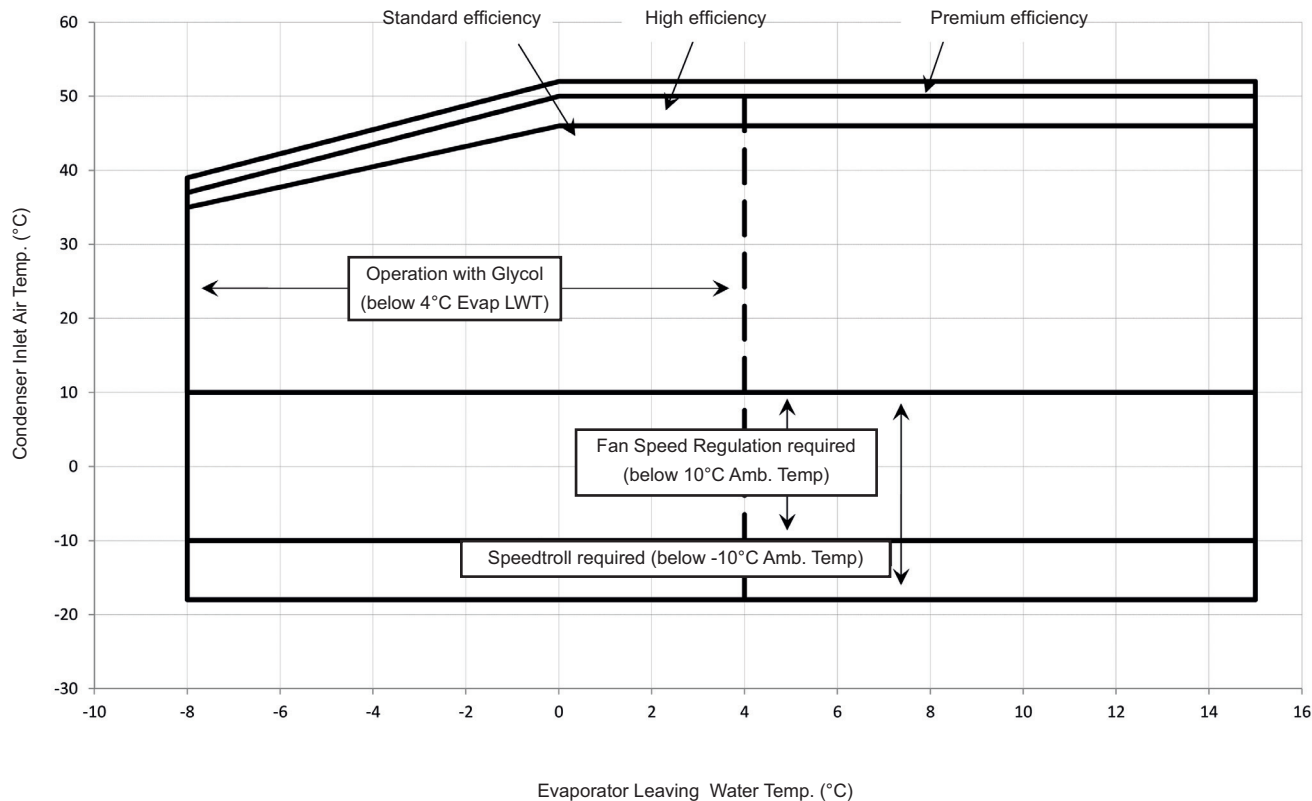

OPL_1-2a-3a_Rev.01_1

Water charge, flow and quality

Items ^{(1) (6)}		Cooling Water			Cooled Water		Heated water ⁽²⁾				Tendency if out of criteria		
		Circulating System		Once Flow	Circulating water [Below 20°C]	Supply water ⁽⁴⁾	Low temperature [20°C ~ 60°C]		High temperature [60°C ~ 80°C]				
		Circulating water	Supply water ⁽⁴⁾	Flowing water			Circulating water	Supply water ⁽⁴⁾	Circulating water	Supply water ⁽⁴⁾			
Items to be controlled	pH	at 25°C		6.5 ~ 8.2	6.0 ~ 8.0	6.0 ~ 8.0	6.8 ~ 8.0	6.0 ~ 8.0	7.0 ~ 8.0	7.0 ~ 8.0	7.0 ~ 8.0	7.0 ~ 8.0	Corrosion + Scale
	Electrical conductivity	[mS/m] at 25°C		Below 80	Below 30	Below 40	Below 80	Below 80	Below 30	Below 30	Below 30	Below 30	Corrosion + Scale
		[µS/cm] at 25°C		(Below 800)	(Below 300)	(Below 400)	(Below 800)	(Below 800)	(Below 300)	(Below 300)	(Below 300)	(Below 300)	Corrosion + Scale
	Chloride ion	[mgCl ⁻ /l]		Below 200	Below 50	Below 50	Below 200	Below 50	Below 50	Below 50	Below 30	Below 30	Corrosion
	Sulfate ion	[mgSO ₄ ⁻² /l]		Below 200	Below 50	Below 50	Below 200	Below 50	Below 50	Below 50	Below 30	Below 30	Corrosion
	M-alkalinity (pH4.8)	[mgCaCO ₃ /l]		Below 100	Below 50	Below 50	Below 100	Below 50	Below 50	Below 50	Below 50	Below 50	Scale
	Total hardness	[mgCaCO ₃ /l]		Below 200	Below 70	Below 70	Below 200	Below 70	Below 70	Below 70	Below 70	Below 70	Scale
	Calcium harness	[mgCaCO ₃ /l]		Below 150	Below 50	Below 50	Below 50	Below 50	Below 50	Below 50	Below 50	Below 50	Scale
	Silica ion	[mgSiO ₂ /l]		Below 50	Below 30	Below 30	Below 30	Below 30	Below 30	Below 30	Below 30	Below 30	Scale
	Oxygen	(mg O ₂ /l)		Below 1.0	Below 1.0	Below 1.0	Below 1.0	Below 1.0	Below 1.0	Below 1.0	Below 1.0	Below 1.0	Corrosion
	Particulate size	(mm)		Below 0.5	Below 0.5	Below 0.5	Below 0.5	Below 0.6	Below 0.5	Below 0.6	Below 0.5	Below 0.6	Erosion
	Total dissolved solids	(mg / l)		Below 1000	Below 1000	Below 1000	Below 1000	Below 1001	Below 1000	Below 1001	Below 1000	Below 1001	Erosion
Items to be referred to	Ethykene, Propylene Glycol (weight conc.)	Below 60%		Below 60%	---	Below 60%	Below 60%	Below 60%	Below 60%	Below 60%	Below 60%	--	
	Nitrate ion	(mg NO ₃ ⁻ /l)		Below 100	Below 100	Below 100	Below 100	Below 101	Below 100	Below 100	Below 100	Below 101	Corrosion
	TOC Total organic carbon	(mg /l)		Below 1.0	Below 1.0	Below 1.0	Below 1.0	Below 1.0	Below 1.0	Below 1.0	Below 1.0	Below 1.0	Scale
	Iron	[mgFe/l]		Below 1.0	Below 0.3	Below 1.0	Below 1.0	Below 0.3	Below 1.0	Below 0.3	Below 1.0	Below 0.3	Corrosion + Scale
	Copper	[mgCu/l]		Below 0.3	Below 0.1	Below 1.0	Below 1.0	Below 1.0	Below 1.0	Below 0.1	Below 1.0	Below 0.1	Corrosion
	Sulfite ion	[mgS ₂ ⁻² /l]		Not detectable	Not detectable	Not detectable	Not detectable	Not detectable	Not detectable	Not detectable	Not detectable	Not detectable	Corrosion
	Ammonium ion	[mgNH ₄ ⁺ /l]		Below 1.0	Below 0.1	Below 1.0	Below 1.0	Below 0.1	Below 0.3	Below 0.1	Below 0.1	Below 0.1	Corrosion
	Remaining chloride	[mgCl/l]		Below 0.3	Below 0.3	Below 0.3	Below 0.3	Below 0.3	Below 0.25	Below 0.3	Below 0.1	Below 0.3	Corrosion
	Free carbide	[mgCO ₂ /l]		Below 4.0	Below 4.0	Below 4.0	Below 4.0	Below 4.0	Below 0.4	Below 4.0	Below 0.4	Below 4.0	Corrosion
	Stability index			6.0 ~ 7.0	---	---	---	---	---	---	---	---	Corrosion + Scale

NOTES

- Names, definitions and units are according to JIS K 0101. Units and figures between brackets are old units published as reference only.
- In case of using heated water (more than 40°C), corrosion is generally noticeable. Especially when the iron materials is in direct contact with water without any protection shields, it is desirable to give the valid measure for corrosion. E.g. chemical measure.
- In the cooling water using hermetic cooling tower, close circuit water is according to heated water standard, and scattered water is according to cooling water standard.
- Supply water is considered drink water, industrial water and ground water except for genuine water, neutral water and soft water.
- The above mentioned items are representable items in corrosion and scale cases.
- The limits above have to be considered as a general prescription and can not totally assure the absence of corrosion and erosion. Some particular combinations of elements or the presence of components not listed in the table or factors not considered may trigger corrosion phenomena.

OPL_1-2a-3a_Rev.01_2a

11 Operation range

11 - 1 Operation Range

Water content in cooling circuits

The cooled water distribution circuits should have minimum water content to avoid excessive compressors start and stop. In fact, each time the compressor starts up, an excessive quantity of oil goes from the compressor sump and simultaneously there is a rise in the temperature of the compressor motor's stator due to the inrush current during the start-up. To prevent damage to the compressors, it has been envisaged the application of a device to limit frequent stops and restarts.

During the span of one hour there will be no more than 6 starts of the compressor. The plant side should therefore ensure that the overall water content allows a more constant functioning of the unit and consequently greater environmental comfort. The minimum water content per unit should be calculated using this simplified formula:

For 2 compressors unit

$$M \text{ (liters)} = (0.1595 \times \Delta T(^{\circ}\text{C}) + 3.0825) \times P(\text{kW})$$

For 3 compressors unit

$$M \text{ (liters)} = (0.0443 \times \Delta T(^{\circ}\text{C}) + 1.6202) \times P(\text{kW})$$

where:

- M minimum water content per unit expressed in litres
- P Cooling Capacity of the unit expressed in kW
- ΔT evaporator entering / leaving water temperature difference expressed in $^{\circ}\text{C}$

This formula is valid for:

- standard microprocessor parameters

For more accurate determination of quantity of water, it is advisable to contact the designer of the plant.

12 Hydraulic performance

12 - 1 Water Pressure Drop Curve Evaporator

12

Evaporating Pressure Drops

EWAD~C-SS EWAD~C-SL	650	740	830	910	970	C11	C12	C14	C15	C16	C17
Cooling Capacity (kW)	647	744	832	912	967	1064	1152	1419	1538	1622	1714
Water Flow (l/s)	30.90	35.56	39.74	43.60	46.21	50.85	55.04	67.78	73.5	77.51	81.89
Pressure Drops (kPa)	73	59	52	61	68	63	72	47	59	65	73

Water flow and pressure drop referred to nominal condition: evaporator water in/out: 12/7°C – condenser air inlet: 35°C

EWAD~C-SR	650	740	830	910	970	C11	C12	C14	C15	C16	C17
Cooling Capacity (kW)	619	715	789	876	922	1020	1112	1367	1471	1556	1623
Water Flow (l/s)	29.57	34.15	37.71	41.83	44.05	48.75	53.11	65.32	70.28	74.32	77.57
Pressure Drops (kPa)	67	55	47	57	62	58	68	44	54	60	66

Water flow and pressure drop referred to nominal condition: evaporator water in/out: 12/7°C – condenser air inlet: 35°C

EWAD~C-XS EWAD~C-XL	760	830	890	990	C10	C11	C12	C13	C14	C15	C16	C17	C18	C19
Cooling Capacity (kW)	756	830	889	1001	1074	1196	1280	1349	1409	1526	1596	1685	1768	1858
Water Flow (l/s)	36.10	39.67	42.49	47.82	51.32	57.13	61.18	64.45	67.34	72.90	76.24	80.48	84.47	88.79
Pressure Drops (kPa)	80	56	64	61	69	45	51	71	77	57	62	68	64	37

Water flow and pressure drop referred to nominal condition: evaporator water in/out: 12/7°C – condenser air inlet: 35°C

EWAD~C-XR	760	830	890	990	C10	C11	C12	C13	C14	C15	C16	C17	C18	C19
Cooling Capacity (kW)	736	811	866	974	1041	1168	1247	1302	1378	1486	1550	1639	1722	1813
Water Flow (l/s)	35.17	38.74	41.36	46.54	49.76	55.78	59.56	62.21	65.85	70.98	74.07	78.32	82.3	86.61
Pressure Drops (kPa)	76	54	61	58	65	43	49	67	74	54	59	65	61	35

Water flow and pressure drop referred to nominal condition: evaporator water in/out: 12/7°C – condenser air inlet: 35°C

EWAD~C-PS EWAD~C-PL	820	890	980	C11	C12	C13	C14
Cooling Capacity (kW)	821	890	975	1074	1158	1279	1390
Water Flow (l/s)	39.22	42.53	46.6	51.30	55.31	61.12	66.41
Pressure Drops (kPa)	57	65	30	61	69	60	73

Water flow and pressure drop referred to nominal condition: evaporator water in/out: 12/7°C – condenser air inlet: 35°C

EWAD~C-PR	820	890	980	C11	C12	C13	C14
Cooling Capacity (kW)	809	875	956	1053	1132	1251	1359
Water Flow (l/s)	38.65	41.81	45.69	50.30	54.11	59.76	64.95
Pressure Drops (kPa)	56	63	29	59	66	58	70

Water flow and pressure drop referred to nominal condition: evaporator water in/out: 12/7°C – condenser air inlet: 35°C

Evaporating Pressure Drops

To determine the pressure drop for different versions or at different working conditions, please refer to the following formula:

$$PD_2 \text{ (kPa)} = PD_1 \text{ (kPa)} \times \left(\frac{Q_2 \text{ (l/s)}}{Q_1 \text{ (l/s)}} \right)^{1.8}$$

where:

- PD₂ Pressure drop to be determinate (kPa)
- PD₁ Pressure drop at nominal condition (kPa)
- Q₂ water flow at new working condition (l/s)
- Q₁ water flow at nominal condition (l/s)

How to use the formula: Example

The unit EWAD650C-SS has been selected for working at the following conditions:

- evaporator water in/out : 11/6°C

- condenser air inlet: 46°C

The cooling capacity at these working conditions is: 536 kW

The water flow at these working conditions is: 25.61 l/s

The unit EWAD650C-SS at nominal working conditions has the following data:

- evaporator water in/out : 12/7°C

- condenser air inlet: 35°C

The cooling capacity at these working conditions is: 647 kW

The water flow at these working conditions is: 30.90 l/s

The pressure drop at these working conditions is: 73 kPa

The pressure drop at the selected working condition will be:

$$PD_2 \text{ (kPa)} = 73 \text{ (kPa)} \times \left(\frac{25.61 \text{ (l/s)}}{30.90 \text{ (l/s)}} \right)^{1.8}$$

$$PD_2 \text{ (kPa)} = 52 \text{ (kPa)}$$

NOTES

If the calculated evaporator water pressure drop is below 10 kPa or above 100 kPa please contact the factory for dedicated evaporator.

13 Specification text

13 - 1 Specification Text

General The chiller will be designed and manufactured in accordance with the following European directives:

- Construction of pressure vessel 97/23/EC (PED)
- Machinery Directive 2006/42/EC
- Low Voltage 2006/95/EC
- Electromagnetic Compatibility 2004/108/EC
- Electrical & Safety codes EN 60204-1 / EN 60335-2-40
- Manufacturing Quality Standards UNI – EN ISO 9001:2004

To avoid any losses, the unit will be tested at full load in the factory (at the nominal working conditions and water temperatures). The chiller will be delivered to the job site completely assembled and charged with refrigerant and oil. The installation of the chiller must comply with the manufacturer’s instructions for rigging and handling equipment.

The unit will be able to start up and operate (as standard) at full load with:
 - outside air temperature from °C to °C
 - evaporator leaving fluid temperature between °C and °C

Refrigerant Only R-134a can be used.

Performance Chiller shall supply the following performances:

- Number of chiller(s) : unit(s)
- Cooling capacity for single chiller : kW
- Power input for single chiller in cooling mode : kW
- Heat exchanger entering water temperature in cooling mode : °C
- Heat exchanger leaving water temperature in cooling mode : °C
- Heat exchanger water flow : l/s
- Nominal outside working ambient temperature in cooling mode : °C

Operating voltage range should be 400V ±10%, 3ph, 50Hz, voltage unbalance maximum 3%, without neutral conductor and shall only have one power connection point.

Unit description Chiller shall include as standard not less than: two or three independent refrigerant circuits (depending on the size), semi-hermetic asymmetric type rotary single screw compressors, electronic expansion device (EEXV), refrigerant direct expansion ‘shell&tube’ heat exchanger, air-cooled condenser section, R-134a refrigerant, lubrication system, motor starting components, discharge line shut-off valve, control system and all components necessary for a safe and stable unit operation. The chiller will be factory assembled on a robust base frame made of galvanized steel, protected by an epoxy paint.

Sound level and vibrations Sound pressure level at 1 meter distance in free field, semispheric conditions, shall not exceeddB(A). The sound pressure levels must be rated in accordance to ISO 3744 (other types of rating can not be used). Vibration on the base frame should not exceed 2 mm/s.

Dimensions Unit dimensions shall not exceed following indications:

- Unit length mm
- Unit width mm
- Unit height mm

Compressors (Asymmetric) The unit shall be equipped with:

- Semi-hermetic, single-screw asymmetric type with one main helical rotor meshing with two diametrical opposed gaterotors. The gaterotors’ contact elements shall be constructed of composite material designed for extended life. Electrical motor shall be 2-pole, semi-hermetic, squirrel-cage induction type and cooled by suction gas.
- The oil injection shall be used in order to get high EER (Energy Efficiency Ratio) also at high condensing pressure and low sound pressure levels in each load condition.
- The compressor shall be provided with a built in, high efficiency, mesh type oil separator and oil filter.
- Refrigerant system differential pressure shall provide oil injection on all moving compressor parts to correctly lubricate them. Electrical oil pump lubricating system is not allowed.
- Compressor cooling must be done by refrigerant liquid injection. An external dedicated heat exchanger and additional piping to carry the oil from compressor to heat exchanger and viceversa is not allowed.
- The compressor shall be direct electrical driven, without gear transmission between the screw and the electrical motor.
- The compressor casing shall be provided with ports to realize economized refrigerant cycles.
- The compressor must be protected by a temperature sensor for high discharge temperature and an electrical motor thermistor for high winding temperature.
- The compressor shall be equipped with an electric oil heater.
- The compressor shall be fully field serviceable. Compressor that must be removed and returned to the factory for service shall be unacceptable.

SPC_1b-2a-3_Rev.02_1b

13 Specification text

13 - 1 Specification Text

13

Evaporator The units shall be equipped with a direct expansion shell&tube evaporator with copper tubes rolled into steel tubesheets. The evaporator shall be single-pass on both the refrigerant and water sides for pure counter-flow heat exchange and low refrigerant pressure drops.

- The external shell shall be linked with an electrical heater to prevent freezing down to -28°C ambient temperature, controlled by a thermostat and shall be insulated with flexible, closed cell polyurethane insulation material (20-mm thick).
- The evaporator will have 2 or 3 circuits, one for each compressor and shall be single refrigerant pass.
- The water connections shall be VICTAULIC type connections as standard to ensure quick mechanical disconnection between the unit and the hydronic network.
- The evaporator will be manufactured in accordance to PED approval.

Condenser coil The unit shall be equipped with condenser coils constructed with internally finned seamless copper tubes and arranged in a staggered row pattern and mechanically expanded into lanced and rippled aluminium fins with full fin collars for higher efficiencies. The space between the fins is given by a collar that will increase the surface area in connection with the tubes, protecting them from ambient corrosion.

- The condenser coils will have an integral subcooler circuit that provides sufficient subcooling to effectively eliminate the possibility of liquid flashing and increase the unit's efficiency with 5% to 7% without increasing in energy consumption.
- The condenser coils shall be leak-tested and submitted to a pressure test with dry air.

Condenser fans The condenser fans used in conjunction with the condenser coils, shall be propeller type with glass reinforced resin blades for higher efficiencies and lower sound. Each fan shall be protected by a fan guard.

- The air discharge shall be vertical and each fan must be coupled to the electrical motor, supplied as standard to IP54 and capable to work to ambient temperatures of - 20°C to + 65°C.
- The condenser fans shall have as a standard a thermally protection by internal thermal motor protection and protected by circuit breaker installed inside the electrical panel as a standard.

Refrigerant circuit The unit shall have two or three refrigerant circuits (depending on the size).

- The circuit shall include as standard: electronic expansion device piloted by unit's microprocessor control, compressor discharge shut-off valve, liquid line shut-off valve, sight glass with moisture indicator, replaceable filter drier, charging valves, high pressure switch, high and low pressure transducers, oil pressure transducer and insulated suction line.

Low sound unit configurations (on request) The unit compressor shall be connected with unit's metal base frame by rubber antivibration supports to prevent the transmission of vibrations to all metal unit structure, in order to control the unit sound.

- The chiller shall be provided with an acoustical compressor enclosure. This enclosure shall be realized with a light, corrosion resisting aluminium structure and metal panels. The compressor sound-proof enclosure shall be internally fitted with flexible, multi-layer, high density materials.

Hydronic kit options (on request) The hydronic module shall be integrated in the chiller chassis without increasing its dimensions and includes the following elements: centrifugal pump with motor protected by a circuit breaker installed in control panel, water filling system with pressure gauge, safety valve, drain valve.

- The hydronic module shall be assembled and wired to the control panel.
- The water piping shall be protected against corrosion and freezing and insulated to prevent condensation.
- A choice of two pump types shall be available:
 - in-line single pump
 - in-line twin pumps.

13 Specification text

13 - 1 Specification Text

Electrical control panel Power and control shall be located in the main panel that will be manufactured to ensure protection against all weather conditions.

- The electrical panel shall be IP54 and (when opening the doors) internally protected with plexiglas panel against possible accidental contact with electrical components (IP20).
- The main panel shall be fitted with a main switch interlocked door.
- The power section will include compressors and fans protection devices, compressors and fans starters and control circuit power supply.

Controller The controller will be installed as standard and it will be used to modify unit set-points and check control parameters.

- A built-in display will show chiller operating status plus temperatures and pressures of water, refrigerant and air, programmable values, set-points.
- A sophisticated software with predictive logic, will select the most energy efficient combination of compressors, EEXV and condenser fans to keep stable operating conditions to maximise chiller energy efficiency and reliability.
- The controller will be able to protect critical components based on external signs from its system (such as motor temperatures, refrigerant gas and oil pressures, correct phase sequence, pressure switches and evaporator). The input coming from the high pressure switch cuts all digital output from the controller in less than 50ms, this will be an additional security for the equipment.
- Fast program cycle (200ms) for a precise monitoring of the system.
- Floating point calculations supported for increased accuracy in P/T conversions.

Controller main features

- Management of the compressor stepless capacity and fans modulation.
- Chiller enabled to work in partial failure condition.
- Full routine operation at condition of:
 - high ambient temperature value
 - high thermal load
 - high evaporator entering water temperature (start-up)
- Display of evaporator entering/leaving water temperature.
- Display of Outdoor Ambient Temperature.
- Display of condensing-evaporating temperature and pressure, suction and discharge superheat for each circuit.
- Leaving water evaporator temperature regulation (temperature tolerance = 0,1°C).
- Compressor and evaporator pumps hours counter.
- Display of Status Safety Devices.
- Number of starts and compressor working hours.
- Optimized management of compressor load.
- Fan management according to condensing pressure.
- Re-start in case of power failure (automatic / manual).
- Soft Load (optimized management of the compressor load during the start-up).
- Start at high evaporator water temperature.
- Return Reset (Set Point Reset based on return water temperature).
- OAT (Outside Ambient temperature) Reset.
- Set point Reset (optional).
- Application and system upgrade with commercial SD cards.
- Ethernet port for remote or local servicing using standard web browsers.
- Two different sets of default parameters could be stored for easy restore.

High Level Communications Interface (on request) The chiller shall be able to communicate to BMS (Building Management System) based on the most common protocols as:

- ModbusRTU
- LonWorks, now also based on the international 8040 Standard Chiller Profile and LonMark Technology
- BacNet BTP certified over IP and MS/TP (class 4) (Native)
- Ethernet TCP/IP.

SPC_1b-2a-3_Rev.02_3



Daikin's unique position as a manufacturer of air conditioning equipment, compressors and refrigerants has led to its close involvement in environmental issues. For several years Daikin has had the intention to become a leader in the provision of products that have limited impact on the environment. This challenge demands the eco design and development of a wide range of products and an energy management system, resulting in energy conservation and a reduction of waste.



Daikin Europe N.V. participates in the Eurovent Certification programme for Air conditioners (AC), Liquid Chilling Packages (LCP) and Fan coil units (FCU). Check on-going validity of certificate online: www.eurovent-certification.com or using: www.certiflash.com

The present leaflet is drawn up by way of information only and does not constitute an offer binding upon Daikin Europe N.V.. Daikin Europe N.V. has compiled the content of this leaflet to the best of its knowledge. No express or implied warranty is given for the completeness, accuracy, reliability or fitness for particular purpose of its content and the products and services presented therein. Specifications are subject to change without prior notice. Daikin Europe N.V. explicitly rejects any liability for any direct or indirect damage, in the broadest sense, arising from or related to the use and/or interpretation of this leaflet. All content is copyrighted by Daikin Europe N.V.

BARCODE

Daikin products are distributed by: