



Chillers

Technical Data

Large Air Cooled Chillers



EEDEN13-416

EWYD-BZSS
EWYD-BZSL



Chillers

Technical Data

Large Air Cooled Chillers



EEDEN13-416

EWYD-BZSS
EWYD-BZSL

Large Air Cooled Chillers

Air cooled heat pump inverter chiller	1	EWYD-BZSS3	1
Air cooled heat pump inverter chiller	2	EWYD-BZSL45	2

TABLE OF CONTENTS

EWYD-BZSS

1	Features	4
2	Specifications	5
	Technical Specifications	5
	Technical Specifications	6
	Electrical Specifications	7
	Electrical Specifications	7
3	Features and advantages	9
	Features and Advantages	9
4	General Characteristics	11
	General characteristics	11
5	Nomenclature	15
	Nomenclature	15
6	Options	16
	Options	16
7	Capacity tables	22
	Cooling Capacity Tables	22
	Heating Capacity Tables	24
8	Pressure drops	25
	Evaporator Pressure Drops	25
9	Centre of gravity	26
	Centre of Gravity	26
10	Sound data	27
	Sound Level Data	27
11	Installation	30
	Installation Method	30
12	Operation range	32
	Operation Range	32
13	Specification text	39
	Specification Text	39

1 Features

- Optimised for use with R-134a
- Ideal solution for commercial comfort cooling and/or heating applications
- EER range up to 2.83
- Standard electronic expansion valve
- DX shell and tube evaporator – one pass refrigerant side to minimize pressure drops
- Low starting current
- No gas boiler required
- Optimised defrost cycles
- Optimum ESEER values
- Partial and total heat recovery option available
- PID microprocessor control
- Power factor up to 0.95
- 2-3 truly independent refrigerant circuits
- Standard operation range down to -12°C



2 Specifications

2-1 Technical Specifications				EWYD250BZ SS	EWYD270BZ SS	EWYD290BZ SS	EWYD320BZ SS	EWYD340BZ SS	EWYD370BZ SS	EWYD380BZ SS	
Cooling capacity	Nom.		kW	253 (1)	272 (1)	291 (1)	323 (1)	337 (1)	363 (1)	380 (1)	
Heating capacity	Nom.		kW	271 (2)	298 (2)	325 (2)	334 (2)	351 (2)	381 (2)	412 (2)	
Capacity control	Method			Stepless							
	Minimum capacity		%	13							
Power input	Cooling	Nom.	kW	91.3 (1)	101 (1)	109 (1)	117 (1)	126 (1)	136 (1)	144 (1)	
	Heating	Nom.	kW	91.5 (2)	100 (2)	108 (2)	118 (2)	127 (2)	134 (2)	143 (2)	
EER				2.77 (1)	2.70 (1)	2.66 (1)	2.75 (1)	2.69 (1)	2.68 (1)	2.65 (1)	
ESEER				3.93	3.92	3.89	3.95	3.89	3.90	3.82	
COP				2.96 (2)	2.97 (2)	3.01 (2)	2.82 (2)	2.77 (2)	2.85 (2)	2.88 (2)	
IPLV				4.58	4.62		4.75	4.64	4.71	4.67	
Casing	Colour			Ivory white							
	Material			Galvanized and painted steel sheet							
Dimensions	Unit	Height	mm	2,335							
		Width	mm	2,254							
		Depth	mm	3,547			4,381				
Weight	Unit		kg	3,410	3,455	3,500	3,870		3,940	4,010	
	Operation weight		kg	3,550	3,595	3,640	4,010		4,068	4,138	
Water heat exchanger	Type			Single pass shell & tube							
	Water volume			l	138			133		128	
	Nominal water flow	Cooling	l/s	12.12	13.03	13.94	15.46	16.21	17.42	18.25	
		Heating	l/s	12.89	14.18	15.49	15.89	16.66	18.11	19.57	
	Nominal water pressure drop	Cooling	Heat exchanger	kPa	37	42	48	53	58	53	57
		Heating	Heat exchanger	kPa	42.0	49.0	58.0	55.0	60.0	57.0	65.0
Insulation material			Closed cell								
Air heat exchanger	Type			High efficiency fin and tube type with integral subcooler							
Fan	Quantity			6			8				
	Type			Direct propeller							
	Diameter			mm	800						
	Air flow rate	Nom.	l/s	31,728			42,304				
	Speed			rpm	920						
Fan motor	Drive			DOL							
	Input	Heating	W	1,750							
Sound power level	Cooling	Nom.	dBA	100.5			101.2				
	Heating	Nom.	dBA	100.5			101.2				
Sound pressure level	Cooling	Nom.	dBA	82.1			82.3				
	Heating	Nom.	dBA	82.1		82.3			82.5		
Compressor	Type			Semi-hermetic single screw compressor							
	Quantity			2							
	Oil	Charged volume		l	26						
Operation range	Water side	Cooling	Min.	°CDB	-8						
			Max.	°CDB	15						
		Heating	Min.	°CDB	35						
			Max.	°CDB	55						
	Air side	Cooling	Min.	°CDB	-12						
			Max.	°CDB	45						
Heating		Min.	°CDB	-12							
		Max.	°CDB	20							
Refrigerant	Type			R-134a							
	Charge		kg	88	94	100	118		121.0	124	
	Circuits	Quantity		2							
Piping connections	Evaporator water inlet/outlet (OD)			139.7mm							

1
2

2 Specifications

1
2

2-1 Technical Specifications			EWYD250BZ SS	EWYD270BZ SS	EWYD290BZ SS	EWYD320BZ SS	EWYD340BZ SS	EWYD370BZ SS	EWYD380BZ SS
Safety devices	Item	01	High discharge pressure (pressure switch)						
		02	High discharge pressure (pressure transducer)						
		03	Low suction pressure (pressure transducer)						
		04	High discharge temperature						
		05	Low oil pressure						
		06	Low pressure ratio						
		07	High oil filter pressure drop						
		08	Phase monitor						
		09	Compressor overload (Kriwan)						

2-2 Technical Specifications				EWYD410BZSS	EWYD440BZSS	EWYD460BZSS	EWYD510BZSS	EWYD520BZSS	EWYD580BZSS	
Cooling capacity	Nom.	kW		411 (1)	434 (1)	455 (1)	503 (1)	520 (1)	580 (1)	
Heating capacity	Nom.	kW		445 (2)	465 (2)	477 (2)	532 (2)	560 (2)	618 (2)	
Capacity control	Method		Stepless							
	Minimum capacity		%	13			9			
Power input	Cooling	Nom.	kW	154 (1)	165 (1)	163 (1)	180 (1)	188 (1)	218 (1)	
	Heating	Nom.	kW	157 (2)	167 (2)	166 (2)	177 (2)	185 (2)	208 (2)	
EER				2.68 (1)	2.64 (1)	2.79 (1)	2.80 (1)	2.76 (1)	2.66 (1)	
ESEER				3.91	3.89	4.18	4.01		3.93	
COP				2.84 (2)	2.79 (2)	2.87 (2)	3.01 (2)	3.03 (2)	2.97 (2)	
IPLV				4.73	4.69	4.85	4.89	4.85	4.78	
Casing	Colour		Ivory white							
	Material		Galvanized and painted steel sheet							
Dimensions	Unit	Height	mm	2,335						
		Width	mm	2,254						
		Depth	mm	5,281		6,583				
Weight	Unit		kg	4,390		5,015	5,495	5,735		
	Operation weight		kg	4,518		5,255	5,724	5,964	5,953	
Water heat exchanger	Type			Single pass shell & tube						
	Water volume			l	128		240	229		218
	Nominal water flow	Cooling	l/s	19.72	20.81	21.83	24.11	24.92	27.87	
		Heating	l/s	21.15	22.14	22.68	25.33	26.65	29.39	
	Nominal water pressure drop	Cooling	Heat exchanger	kPa	46	51	61	50	53	65
		Heating	Heat exchanger	kPa	52.0	57.0	66.0	55.0	60.0	71.0
Insulation material			Closed cell							
Air heat exchanger	Type			High efficiency fin and tube type with integral subcooler						
Fan	Quantity			10		12				
	Type			Direct propeller						
	Diameter			mm						
	Air flow rate	Nom.	l/s	52,880		63,456				
	Speed			rpm						
Fan motor	Drive			DOL						
	Input	Heating	W	1,750						
Sound power level	Cooling	Nom.	dBA	101.8		103.6				
	Heating	Nom.	dBA	101.8		103.6				
Sound pressure level	Cooling	Nom.	dBA	82.5		83.7				
	Heating	Nom.	dBA	82.5	83.7					
Compressor	Type			Semi-hermetic single screw compressor						
	Quantity			2		3				
	Oil	Charged volume	l	26		39				

2 Specifications

2-2 Technical Specifications					EWYD410BZSS	EWYD440BZSS	EWYD460BZSS	EWYD510BZSS	EWYD520BZSS	EWYD580BZSS	
Operation range	Water side	Cooling	Min.	°CDB	-8						
			Max.	°CDB	15						
		Heating	Min.	°CDB	35						
			Max.	°CDB	55						
	Air side	Cooling	Min.	°CDB	-12						
			Max.	°CDB	45						
Heating		Min.	°CDB	-12							
		Max.	°CDB	20							
Refrigerant	Type				R-134a						
	Charge			kg	148		177		183		186
	Circuits		Quantity			2		3			
Piping connections	Evaporator water inlet/outlet (OD)				139.7mm			219.1mm			
Safety devices	Item	01			High discharge pressure (pressure switch)						
		02			High discharge pressure (pressure transducer)						
		03			Low suction pressure (pressure transducer)						
		04			High discharge temperature						
		05			Low oil pressure						
		06			Low pressure ratio						
		07			High oil filter pressure drop						
		08			Phase monitor						
		09			Compressor overload (Kriwan)						

2-3 Electrical Specifications					EWYD250BZ SS	EWYD270BZ SS	EWYD290BZ SS	EWYD320BZ SS	EWYD340BZ SS	EWYD370BZ SS	EWYD380BZ SS	
Compressor	Phase				3~							
	Voltage			V	400							
	Voltage range	Min.	%		-10							
		Max.	%		10							
	Maximum running current			A	107				146			
Starting method				VFD driven								
Compressor 2	Maximum running current			A	107				146			
Power supply	Phase				3~							
	Frequency			Hz	50							
	Voltage			V	400							
	Voltage range	Min.	%		-10							
Max.		%		10								
Unit	Maximum starting current			A	217			264		296		
	Nominal running current (RLA)	Cooling	A	150 (6)	167 (6)	181 (6)	196 (6)	209 (6)	224 (6)	237 (6)		
		Heating	A	153 (7)	167 (7)	178 (7)	197 (7)	210 (7)	222 (7)	235 (7)		
	Maximum running current			A	238			285		324		
Max unit current for wires sizing			A	262			314		356			
Fans	Nominal running current (RLA)			A	4							

2-4 Electrical Specifications					EWYD410BZSS	EWYD440BZSS	EWYD460BZSS	EWYD510BZSS	EWYD520BZSS	EWYD580BZSS	
Compressor	Phase				3~						
	Voltage			V	400						
	Voltage range	Min.	%		-10						
		Max.	%		10						
	Maximum running current			A	146	176	107	146			
Starting method				VFD driven							
Compressor 2	Maximum running current			A	176		107	146			
Power supply	Phase				3~						
	Frequency			Hz	50						
	Voltage			V	400						
	Voltage range	Min.	%		-10						
Max.		%		10							

2 Specifications

2-4 Electrical Specifications			EWYD410BZSS	EWYD440BZSS	EWYD460BZSS	EWYD510BZSS	EWYD520BZSS	EWYD580BZSS	
Unit	Maximum starting current		A	334	358	328	398	430	
	Nominal running current (RLA)	Cooling	A	255 (6)	273 (6)	271 (6)	300 (6)	313 (6)	357 (6)
		Heating	A	260 (7)	276 (7)	275 (7)	296 (7)	309 (7)	342 (7)
	Maximum running current		A	362	392	369	447	486	
	Max unit current for wires sizing		A	398	431	460	492	535	
Fans	Nominal running current (RLA)		A	4					

Notes

- (1) Cooling: entering evaporator water temp. 12°C; leaving evaporator water temp. 7°C; ambient air temp. 35°C; full load operation.
- (2) Heating: entering condenser water temp. 40°C; leaving condenser water temp. 45°C; ambient air temp. 7°CDB; unit at full load operation
- (3) Sound pressure levels are measured at entering evaporator water temp. 12°C; leaving evaporator water temp. 7°C; ambient air temp. 35°C; full load operation; Standard: ISO3744
- (4) Allowed voltage tolerance ± 10%. Voltage unbalance between phases must be within ± 3%.
- (5) Maximum starting current: starting current of biggest compressor + 75 % of maximum current of the other compressor + fans current for the circuit at 75 %
- (6) Cooling: entering evaporator water temp. 12°C; leaving evaporator water temp. 7°C; ambient air temp. 35°C. Compressor + fans current.
- (7) Heating: entering condenser water temp. 40°C; leaving condenser water temp. 45°C; ambient air temp. 7°CDB, 6°CWB + fans current; installation with 25kA short circuit current
- (8) Maximum running current is based on max compressor absorbed current in its envelope and max fans absorbed current
- (9) Maximum current for wires sizing: (compressors full load ampere + fans current) x 1.1

3 Features and advantages

3 - 1 Features and Advantages

EWYD~BZ

Features and advantages

High part load efficiency

EWYD~BZ is the result of careful design, aimed to optimizing the energy efficiency of the chillers, with the objective of bringing down operating costs and improving installation profitability, effectiveness and economical management.

Per European Seasonal Energy Efficiency Ratio (ESEER), chillers operate at design conditions only three percent of the time. As a result better part load efficiencies are required at part load conditions in a heat pump applications. EWYD~BZ maximize chiller efficiency by optimizing single screw compressor operation dramatically reducing the electric power consumption when the motor speed slows.

Seasonal quietness

Very low noise levels in part load conditions are achieved by varying the fan speed, but especially thanks to the variation of compressor frequency, which ensure the minimum noise level at all the time.

Quick comfort conditions

The ability to vary the output power in direct relation to the cooling requirements of the system, allow the possibility to achieve building comfort conditions much faster at start-up.

Low starting current

No current spikes at start-up. The starting current is always lower than current absorbed in the maximum operating conditions (FLA).

Power factor always > 0.95

EWYD~BZ can operate always > 0.95 power factor, which can allows building owners avoid power factor penalties and decreases electrical losses in cable and transformers.

Redundancy

EWYD~BZ has two or three truly independent refrigerant circuits in every size, in order to assure maximum safety for any maintenance, whether planned or not.

Infinitely capacity control

Cooling capacity control is infinitely variable by means of a Inverter driven screw compressor controlled by microprocessor system. Each unit has infinitely variable capacity control from 100% down to 13,5% (two compressors units) and down to 7% (three compressors). This modulation allows the compressor capacity to exactly match the building cooling load without any leaving evaporator water temperature fluctuation. This chilled water temperature fluctuation is avoided only with a stepless control.

With a compressor load step control in fact, the compressor capacity, at partial loads, will be too high or too low compared to the building cooling load. The result is an increase in chiller energy costs, particularly at the part-load conditions at which the chiller operates most of the time.

Units with stepless regulation offer benefits that the units with step regulation are unable to match. The ability to follow the system energy demand at any time and the possibility to provide steady outlet water temperature without deviations from the set-point, are the two points that allow you to understand how the optimum operating conditions of a system can be met only through the use of a unit with step-less regulation.

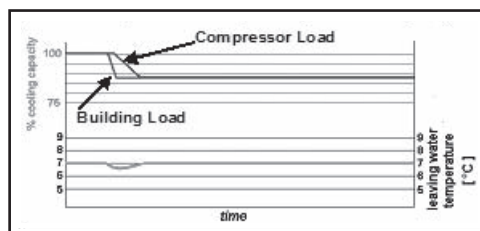

ELWT fluctuation with steps capacity control (4 steps)

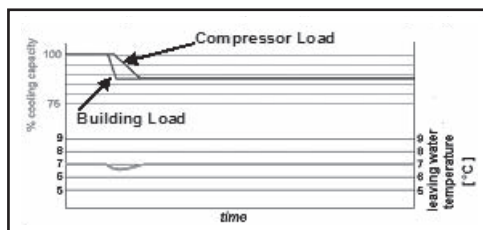

3 Features and advantages

3 - 1 Features and Advantages

EWYD~BZ

Code requirements – Safety and observant of laws/directives

All EWYD~BZ- units are designed and manufactured in accordance with applicable selections of the following:

Rating of chillers	EN 12055
Construction of pressure vessel	97/23/EC (PED)
Machinery Directive	98/37/EC as modified
Low Voltage	2006/95/EC
Electromagnetic Compatibility	2004/108/EC
Electrical & Safety codes	EN 60204–1 / EN 60335-2-40
Manufacturing Quality Stds	UNI – EN ISO 9001:2000

Certifications

All units manufactured by McQuay Italia S.p.A. are CE marked, complying with European directives in force, concerning manufacturing and safety. On request units can be produced complying with laws in force in non European countries (ASME, GOST, etc.), and with other applications, such as naval (RINA, etc.).

Versions

EWYD~BZ is available in the following versions:

S: Standard Efficiency

13 sizes to cover a range from 254 up to 583 kW (Cooling Capacity) and from 270 up to 615 kW (Heating Capacity), with an EER up to 2.87, an ESEER up to 4.29 and a COP up to 3.04.

The EER (Energy Efficiency Ratio) is the ratio of the Cooling Capacity to the Power Input of the unit. The Power Input includes: the power input for operation of the compressor, the power input of all control and safety devices, the power input for fans.

The COP (Coefficient of Performance) is the ratio of the heating capacity to the power input of the unit.

The ESEER (European Seasonal Energy Efficiency Ratio) is a weighed formula enabling to take into account the variation of EER with the load rate and the variation of air inlet condenser temperature.

$$ESEER = A \times EER100\% + B \times EER75\% + C \times EER50\% + D \times EER25\%$$

	A	B	C	D
Coefficient	0.03 (3%)	0.33 (33%)	0.41 (41%)	0.23 (23%)
Air inlet condenser temperature	35°C	30°C	25°C	20°C

Noise Configuration

EWYD~BZ is available in two different noise level configurations:

ST: Standard Noise

Condenser fan rotating at 920 rpm, rubber antivibration on compressor

LN: Low Noise

Condenser fan rotating at 715 rpm (920 rpm in heating mode), rubber antivibration on compressor, compressor sound enclosure.

4 General Characteristics

4 - 1 General characteristics

General characteristics

Cabinet and structure

The cabinet is made of galvanized steel sheet and painted to provide a high resistance to corrosion. Colour Ivory White (Munsell code 5Y7.5/1) (\pm RAL7044). The base frame has eye-hook for lifting the unit with ropes for an easy installation. The weight is uniformly distributed along the profiles of the base and this facilitates the arrangement of the unit.

Screw compressors with integrated oil separator

The compressors are semi-hermetic, single-screw type with gate-rotor (made of carbon impregnated engineered composite material). Each compressor has one inverter managed by the unit microprocessor for infinitely modulating the capacity. An integrated high efficiency oil separator maximises the oil separation.

Start is inverter type.

Ecological HFC 134a refrigerant

The compressors have been designed to operate with R-134a, ecological refrigerant with zero ODP (Ozone Depletion Potential) and very low GWP (Global Warming Potential) that means low TEWI (Total Equivalent Warming Impact).

Evaporator

The units are equipped with a Direct Expansion shell&tube evaporator with copper tubes rolled into steel tubesheets. The evaporators are single-pass on both the refrigerant and water sides for pure counter-flow heat exchange and low refrigerant pressure drops. Both attributes contribute to the heat exchanger effectiveness and total unit's outstanding efficiency.

The external shell is covered with a 10mm closed cell insulation material. Each evaporator has 2 or 3 circuits, one for each compressor and is manufactured in accordance to PED approval. The evaporator water outlet connections are provided with Victaulic Kit (as standard).

Condenser coils

The condenser is manufactured with internally enhanced seamless copper tubes arranged in a staggered row pattern and mechanically expanded into lanced and rippled aluminium condenser fins with full fin collars. An integral sub-cooler circuit provides sub-cooling to effectively eliminate liquid flashing and increase in cooling capacity without increasing the power input.

Condenser coil fans

The condenser fans are propeller type with high efficiency design blades to maximize performances. The material of the blades is glass reinforced resin and each fan is protected by a guard. Fan motor is by circuit breaker installed inside the electrical panel as a standard. The motors are IP54.

Electronic expansion valve

The unit is equipped with the most advanced electronic expansion valves to achieve precise control of refrigerant mass flow. As today's system requires improved energy efficiency, tighter temperature control, wider range of operating conditions and incorporate features like remote monitoring and diagnostics, the application of electronic expansion valves becomes mandatory. Electronic expansion valves possess unique features: short opening and closing time, high resolution, positive shut-off function to eliminate use of additional solenoid valve, continuous modulation of mass flow without stress in the refrigerant circuit and corrosion resistance stainless steel body.

Electronic Expansion Valves are typically working with lower ΔP between high and low pressure side, than a thermostatic expansion valve. The electronic expansion valve allows the system to work with low condenser pressure (winter time) without any refrigerant flow problems and with a perfect chilled water leaving temperature control.

GNC_1a-2a-3a-4a-5c_Rev.03_1a

4 General Characteristics

4 - 1 General characteristics

1
4

Refrigerant Circuit

Each unit has 2 or 3 independent refrigerant circuits and each one includes:

- Compressor with integrated oil separator
- Air Cooled Condenser
- Electronic expansion valve
- Evaporator
- Discharge line shut off valve
- Liquid line shut off valve
- Suction line shut off valve
- Sight glass with moisture indicator
- Filter drier
- Charging valves
- High pressure switch
- High and low pressure transducers

Electrical control panel

Power and control are located in two sections of the main panel that is manufactured to ensure protection against all weather conditions. The electrical panel is IP54 and (when opening the doors) internally protected with Plexiglas panel against possible accidental contact with electrical components (IP20). The main panel is fitted with a main switch interlocked door.

Power Section

The power section includes circuit breaker, compressors inverters, fans contactors, fans thermal overload relays, fans and control circuit transformer.

MicroTech II controller

MicroTech II C Plus controller is installed as standard; it can be used to modify unit set-points and check control parameters. A built-in display shows machine's operating status, programmable values, set-points, like temperatures and pressures of water, refrigerant and air. Device controls maximise the chiller energy efficiency and the reliability. A sophisticated software with predictive logic, select the most energy efficient combination of compressors, EEXV and condenser fans to keep stable operating conditions and maximise energy efficiency. The compressors are automatically rotated to ensure equal operating hours. MicroTech II C Plus protects critical components in response to external signals from its system sensors measuring: motor temperatures, refrigerant gas and oil pressures, correct phase sequence and evaporator.

Control section - main features

- Management of the compressor capacity, Inverter, slide and fans modulation.
- Chillers enabled to work in partial failure condition.
- Full routine operation at condition of:
 - high ambient temperature value,
 - high thermal load,
 - high evaporator entering water temperature (start-up).
- Display of evaporator entering/leaving water temperature.
- Display of condensing-evaporating temperature and pressure, suction and discharge superheat for each circuit.
- Leaving water cooled temperature regulation. Temperature tolerance = 0,1°C.
- Compressors and evaporator pumps hours counter.
- Display of Status Safety Devices.
- Start up numbers and compressors working hours equalization.
- Optimized management of compressors load.
- Fans management according to condensing pressure.
- Automatic re-start in case of power supply interruption (adjustable).
- Soft Load.
- Start at high evaporator water temperature.
- Return Reset.
- AOT Reset (optional).
- Set point Reset (optional).

GNC_1a-2a-3a-4a-5c_Rev.03_2a

4 General Characteristics

4 - 1 General characteristics

Safety device / logic for each refrigerant circuit

- High pressure (pressure switch).
- Low pressure (transducer).
- Condensation fan Magneto-thermal.
- High Discharge Temperature on the compressor.
- Phase Monitor.
- Low pressure ratio.
- High oil pressure drop.
- Low oil pressure.

System security

- Phase monitor.
- Freeze protection.

Regulation type

Proportional + integral + derivative regulation on the leaving water evaporator output probe.

Condensing pressure

The condensation can be carried out according to temperature or pressure or pressure ratio. The fans can be managed according to a 0/10 V modulating signal.

Intelligent Compressor Start Mode

Control software includes an intelligent compressor start mode that unloads the first compressor to 75% during the start of the second one, in order to reduce inrush current.

MicroTech II C Plus terminal

MicroTech II C Plus built-in terminal has the following features.

- 4-lines by 20-character liquid crystal display back lighting.
- Key-pad consisting of 6 keys.
- Memory to protect the data.
- General faults alarm relays.
- Password access to modify the setting.
- Service report displaying all running hours and general conditions.
- Alarm history memory to allow an easy fault analysis.

Supervising systems (on request)

MicroTech II C Plus remote control

MicroTech II C Plus is able to communicate to BMS (Building Management System) based on the most common protocols as:

- CARELNative
- ModbusRTU
- LonWorks, now also based on the international 8040 Standard Chiller Profile and LonMark Technology
- BacNet BTP certified over IP and MS/TP (class 4)
- Ethernet TCP/IP and SNMP.

Standard accessories (supplied on basic unit)

Inverter compressor starter – For low inrush current and reduced starting torque.

Double set-point – Dual leaving water temperature set-points.

Fans circuit breaker thermal overload relays – Safety devices against fan motor overloading and short circuit in addition to the normal protection envisaged by the electrical windings.

Phase monitor – The phase monitor controls that phases sequence is correct and controls phase loss.

Evaporator Victaulic kit on water connection – Hydraulic joint with gasket for an easy and quick water connection.

GNC_1a-2a-3a-4a-5c_Rev.03_3a

4 General Characteristics

4 - 1 General characteristics

1
4

10mm evaporator insulation

Evaporator electric heater – Electric heater controlled by a thermostat to protect the evaporator from freezing down to -28°C ambient temperature, providing the power supply is on.

Electronic expansion valve

Discharge line shut off valves – Installed on the discharge port of the compressor to facilitate maintenance operation.

Suction line shut off valve – Installed on the suction port of the compressor to facilitate maintenance operation.

Outside ambient temperature sensor and reset of leaving water temperature set-point

Compressor hour run meter

General fault – Alarm relay.

Main switch interlock door

Options (on request)

Partial heat recovery – Produced with plate to plate heat exchangers installed between the compressor discharge and the condenser coil, allowing to produce hot water.

Brine version – Allows the unit to operate down to -8°C leaving liquid temperature (antifreeze required).

Under/Over Voltage – This device control the voltage value of power supply and stop the chiller if the value exceeds the allowed operating limits.

Energy Meter – This device allows to measure the energy absorbed by the chiller during its life. It is installed inside the control box mounted on a DIN rail and show on a digital display: Line-to-Line Voltage, Phase and Average Current, Active and Reactive Power, Active Energy, Frequency.

Current limit – To limit maximum absorbed current of the unit whenever is required

20mm evaporator insulation

Fan Silent Mode - The microprocessor clock switches the fan at low speed according to the client setting (i.e. Night & Day), providing that the ambient temperature/condensing pressure is allowing the speed change. It allows a perfect condensing control down to -10°C.

Fan speed regulation – To control the fan speed revolution for smooth operating control of the unit. This option improves the sound level of the unit during low ambient temperature operation.

Condenser coil guards

Cu-Cu condensing coils – To give better protection against corrosion by aggressive environments.

Cu-Cu-Sn condensing coils – To give better protection against corrosion in aggressive environments and by salty air.

Alucoat condensing coils – Fins are protected by a special acrylic paint with a high resistance to corrosion.

Evaporator Flow switch – Supplied separately to be wired and installed on the evaporator water piping (by the customer).

High pressure side manometers

High pressure side manometers

Low pressure side manometers

Set-point reset – The leaving water temperature set-point can be overwritten with the following options: 4-20mA from external source (by user); outside ambient temperature; evaporator water temperature Δt .

Demand limit – User can limit the load of the unit by 4-20mA signal or by network system

Alarm from external device – Microprocessor is able to receive an alarm signal from an external device (pump etc...). User can decide if this alarm signal will stop or not the unit.

Kit container

Rubber type antivibration mounts – Supplied separately, these are positioned under the base of the unit during installation. Ideal to reduce the vibrations when the unit is floor mounted.

Spring type antivibration mounts – Supplied separately, these are positioned under the base of the unit during installation. Ideal for dampening vibrations for installation on roofs and metallic structures.

Water circulation pump (low or high lifting) – Not available for 250÷290 BZSL units. Hydronic kit consists of: single direct driven centrifugal pump, water filling system with pressure gauge, safety valve, drain valve. The motor pump is protected by a circuit breaker installed in control panel. The kit is assembled and wired to the control panel. The pipe and pump are protected from freezing with an additional electrical heater.

Two water circulation pumps (low or high lifting) – Not available for 250÷290 BZSL units. Hydronic kit consists of: twin direct driven centrifugal pumps, water filling system with pressure gauge, safety valve, drain valve. The motor pump is protected by a circuit breaker installed in control panel. The kit is assembled and wired to the control panel. The pipe and pumps are protected from freezing with an additional electrical heater.

Witness test – Every unit is always tested at the test bench prior to the shipment. On request, a second test can be carried out, at customer's presence, in accordance with the procedures indicated on the test form. (Not available for units with glycol mixtures).

Double pressure relief valve with diverter

GNC_1a-2a-3a-4a-5c_Rev.03_4a

5 Nomenclature

5 - 1 Nomenclature

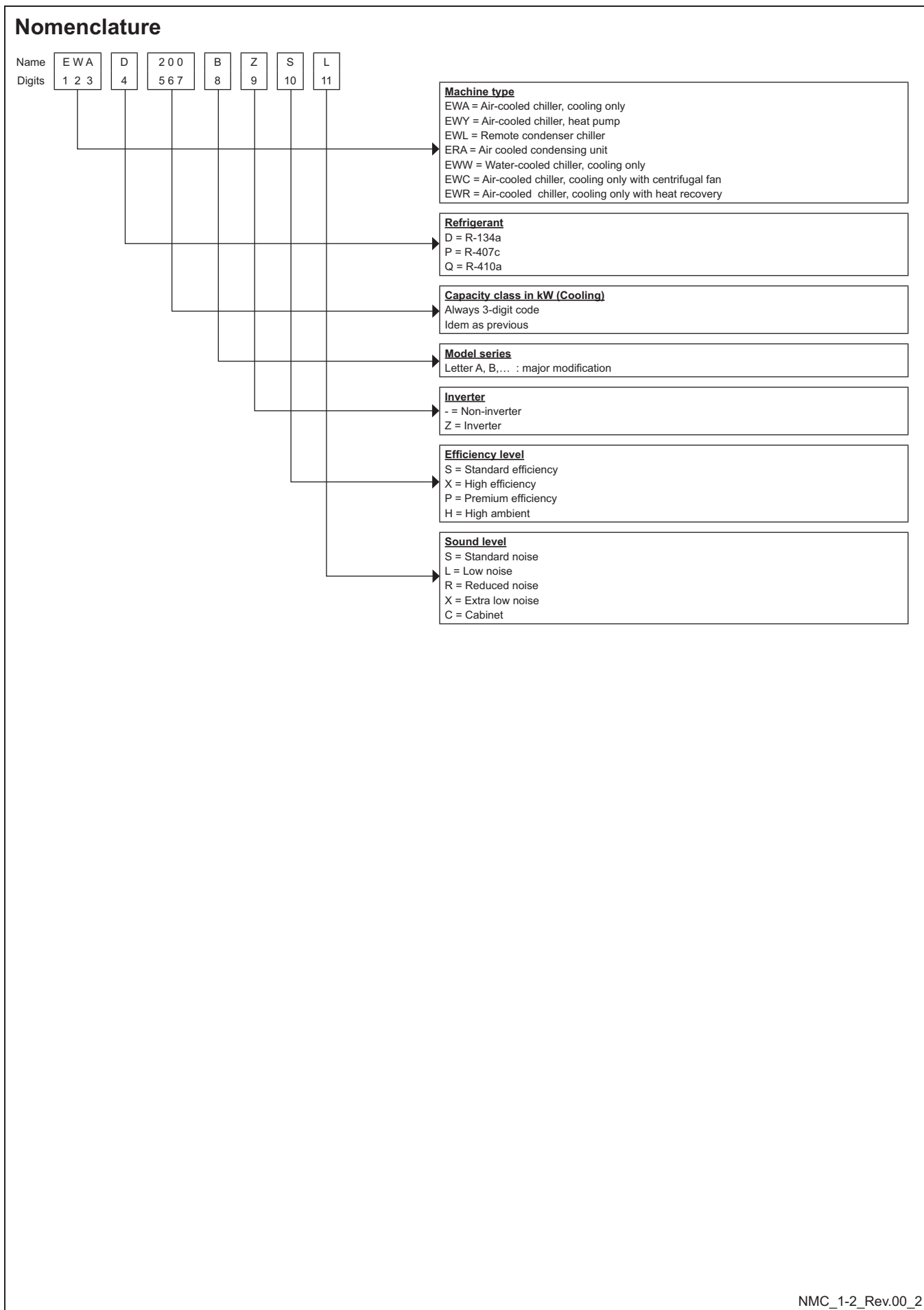

6 Options

6 - 1 Options

1
6

EWYD-BZ

EWYD-BZSS	EWYD-BZSL	Evaporator Leaving Temperature 7°C - Δ15°C Condenser Inlet Air 35°C	1Partial Heat Recovery Leaving Water Temperature (°C)			Partial Heat Rrecovery LWT 45°C	
			45 (Δt=5°C) Hc (kW)	50 (Δt=5°C) Hc (kW)	55 (Δt=5°C) Hc (kW)	Water Flow l/s	Pressure Drops kPa
250	250		74.3	67.8	57.9	3.55	5
270	270		80.9	76.1	65.4	3.87	6
290	290		88.5	85.2	73.5	4.23	7
320	320		93.5	88.2	75.7	4.47	8
340	330		99.4	91.9	78.6	4.75	7
370	360		106	100	85.7	5.06	8
380	370		115	109	94.2	5.49	9
410	400		117	107	96.0	5.60	22
440	130		125	113	102	5.95	24
460	450		133	128	110	6.34	15
510	490		144	135	115	6.86	18
520	510		149	138	118	7.12	14
580	570		173	164	141	8.24	18

OPT_1-2-3-4_Rev.00_1

Partial Heat Recovery Pressure Drops

To determinate the pressure drop for different versions or at different working condition, please refer to the following formula:

$$PD_2 \text{ (kPa)} = PD_1 \text{ (kPa)} \times \left(\frac{Q_2 \text{ (l/s)}}{Q_1 \text{ (l/s)}} \right)^{1.80}$$

where:

- PD₂ Pressure drop to be determinate (kPa)
- PD₁ Pressure drop at nominal condition (kPa)
- Q₂ water flow at new working condition (l/s)
- Q₁ water flow at nominal condition (l/s)

How to use the formula: Example

The unit EWYD250BZSS has been selected for working at the following conditions:
 Partial heat recovery leaving water temperature 50/55°C
 The heating capacity at these working conditions is: 57.9 kW
 The water flow at these working conditions is: 2.77 l/s

The unit EWAD650C-SS at nominal working conditions has the following data:
 - Partial heat recovery leaving water temperature 40/45°C
 - condenser air inlet: 35°C
 The heating capacity at these working conditions is: 74.3 kW
 The water flow at these working conditions is: 3.55 l/s
 The pressure drop at these working conditions is: 5 kPa

The pressure drop at the selected working condition will be:

$$PD_2 \text{ (kPa)} = 5 \text{ (kPa)} \times \left(\frac{2.77 \text{ (l/s)}}{3.55 \text{ (l/s)}} \right)^{1.80}$$

$$PD_2 \text{ (kPa)} = 3 \text{ (kPa)}$$

OPT_1-2-3-4-5_Rev.00_2

6 Options

6 - 1 Options

Water Pump Kit - Discharge Head

Single Pump (2 poles) - Low Available external static pressure

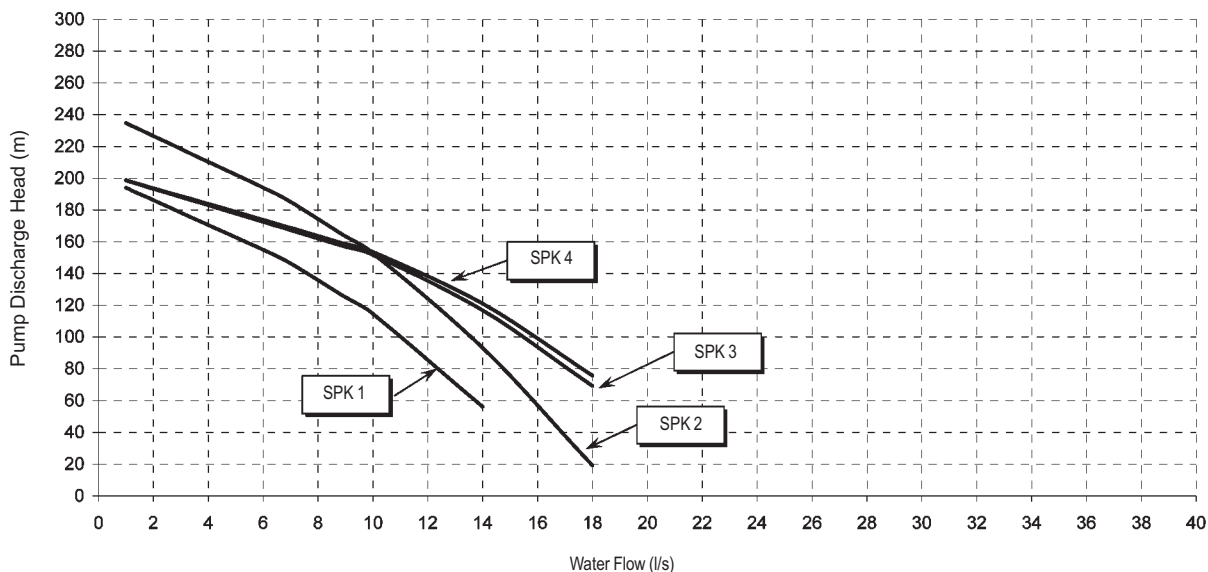

NOTES

- when using mixture of water and glycol please contact the factory as above specification can change

Single Pump (2 poles) - Low Available external static pressure

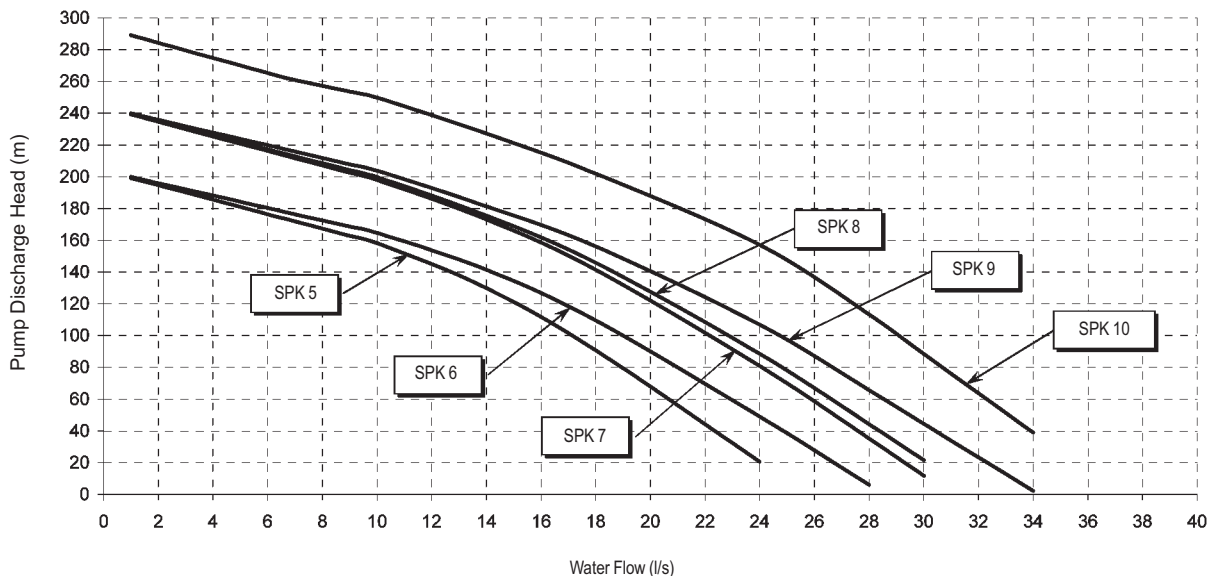

NOTES

- when using mixture of water and glycol please contact the factory as above specification can change

Pump Kit	SPK1	SPK2	SPK3	SPK4		SPK5		SPK6	SPK7	SPK8	SPK9	SPK10	
Size EWYD-BZSS	250	270	290	320	340	370	380	410	440	460	510	520	580
Size EWYD-BZSL	250	270	290	320	330	360	370	400	430	450	490	510	570

6 Options

6 - 1 Options

1
6

Water Pump Kit - Discharge Head

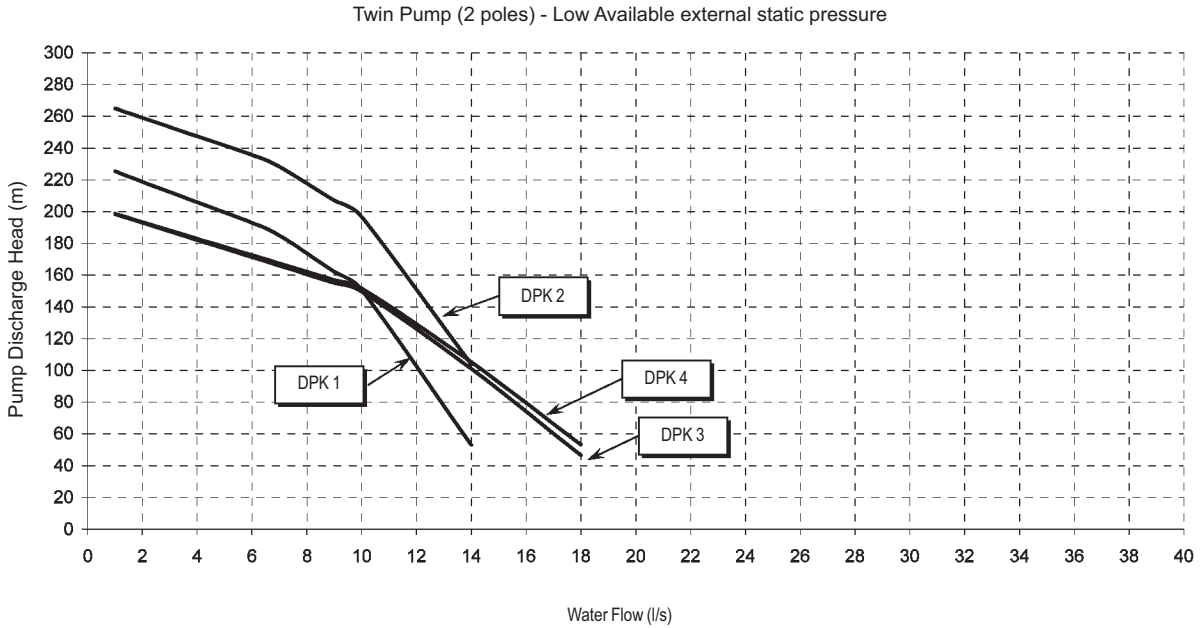

NOTES

- when using mixture of water and glycol please contact the factory as above specification can change

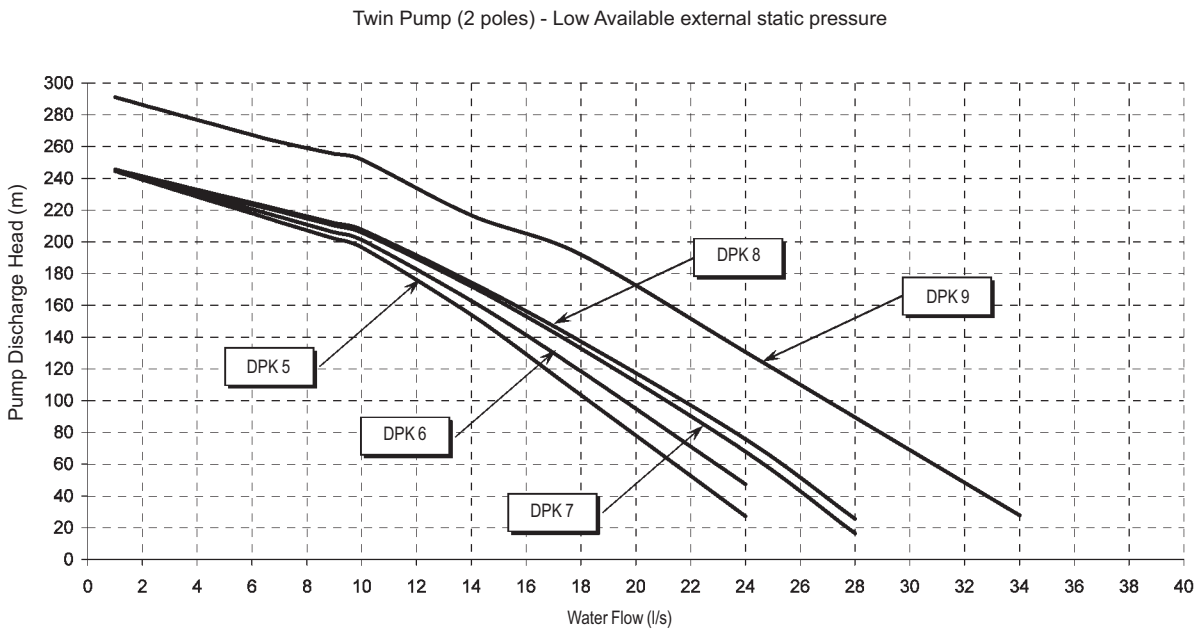

NOTES

- when using mixture of water and glycol please contact the factory as above specification can change

Pump Kit	DPK1	DPK2	DPK3	DPK4	DPK5	DPK6		DPK7		DPK8	DPK9		
Size EWYD-BZSS	250	270	290	320	340	370	380	410	440	460	510	520	580
Size EWYD-BZSL	250	270	290	320	330	360	370	400	430	450	490	510	570

6 Options

6 - 1 Options

Water Pump Kit - Discharge Head

Single Pump (2 poles) - High Available external static pressure

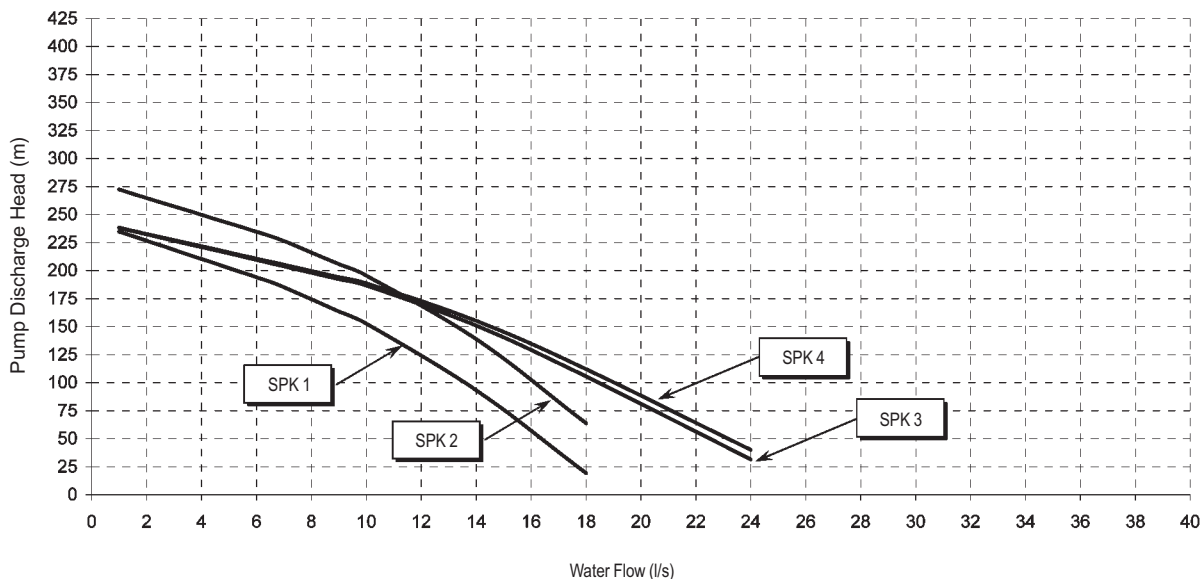

NOTES

- when using mixture of water and glycol please contact the factory as above specification can change

Single Pump (2 poles) - High Available external static pressure

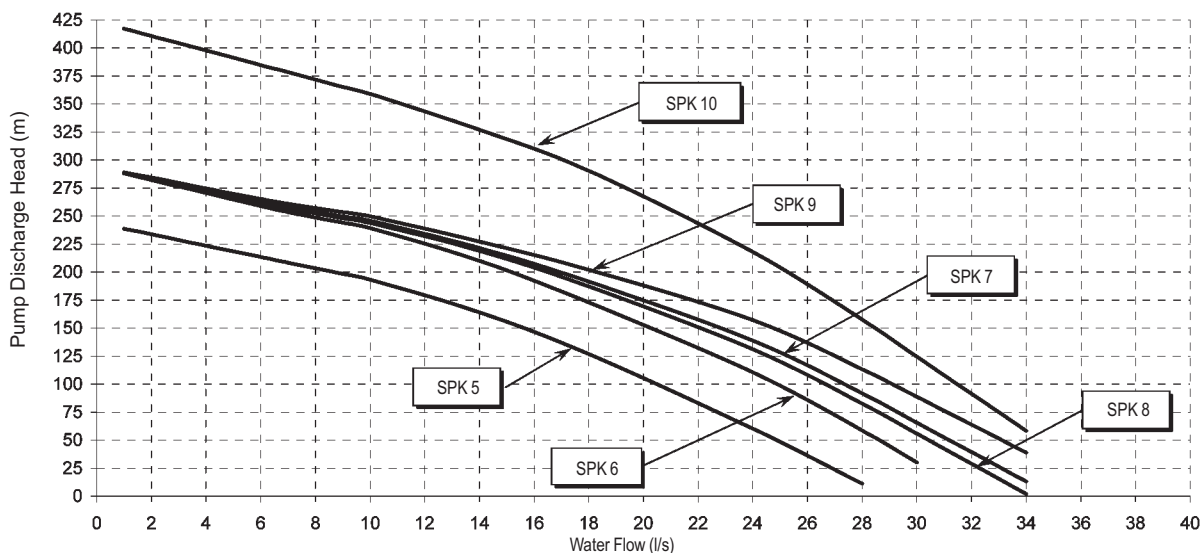

NOTES

- when using mixture of water and glycol please contact the factory as above specification can change

Pump Kit	SPK1	SPK2	SPK3	SPK4	SPK5	SPK6	SPK7	SPK8	SPK9	SPK10			
Size EWYD-BZSS	250	270	290	320	340	370	380	410	440	460	510	520	580
Size EWYD-BZSL	250	270	290	320	330	360	370	400	430	450	490	510	570

6 Options

6 - 1 Options

1
6

Water Pump Kit - Discharge Head

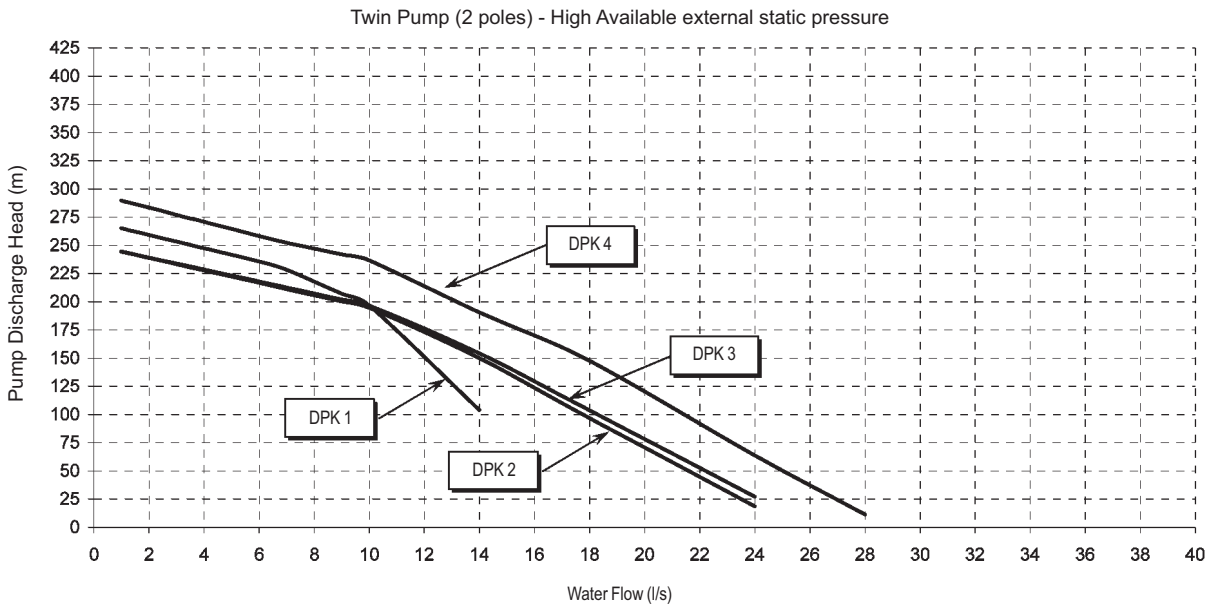

NOTES

- when using mixture of water and glycol please contact the factory as above specification can change

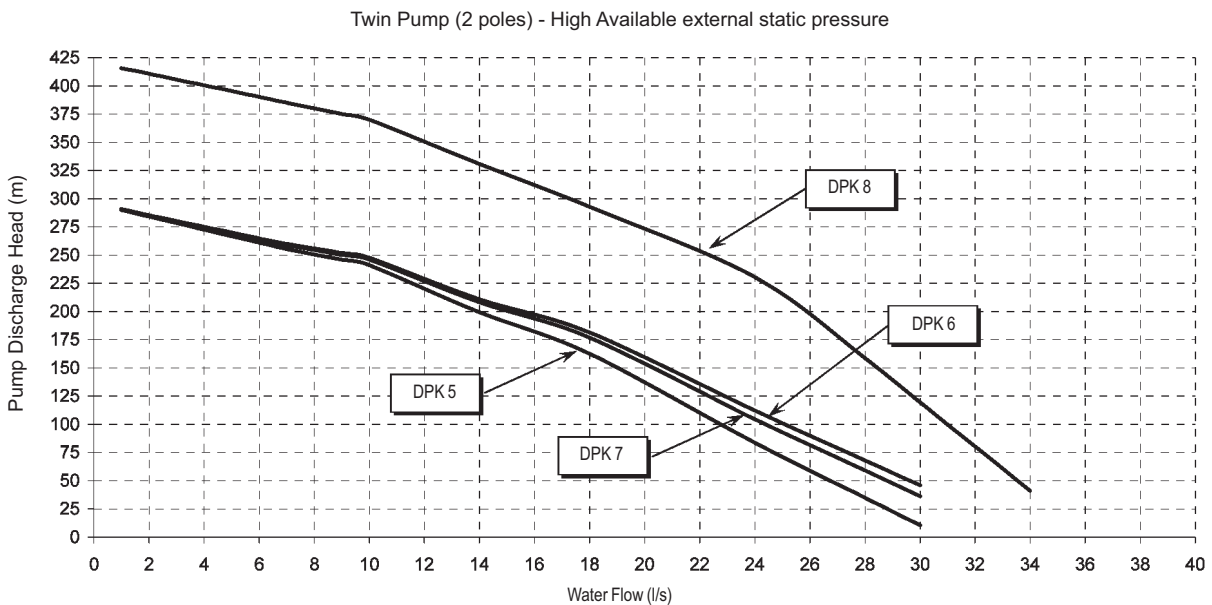

NOTES

- when using mixture of water and glycol please contact the factory as above specification can change

Pump Kit	DPK1	DPK2	DPK3	DPK4	DPK5	DPK6	DPK7	DPK8					
Size EWYD-BZSS	250	270	290	320	340	370	380	410	440	460	510	520	580
Size EWYD-BZSL	250	270	290	320	330	360	370	400	430	450	490	510	570

6 Options

6 - 1 Options

Water Pump Kit - Technical Information

		Pump Motor Power (kW)	Pump Motor Current (A)	Power supply (V-ph-Hz)	PN	Motor Protection	Insulation (Class)	Working Temp. (°C)
Single Pump Low Available Static Pressure	SPK 1	2,2	5,0	400V-3ph-50hz	10	IP55	Class F	-10 + 130
	SPK 2	3,0	6,3	400V-3ph-50hz	10	IP55	Class F	-10 + 130
	SPK 3	4,0	7,7	400V-3ph-50hz	10	IP55	Class F	-10 + 130
	SPK 4	4,0	7,7	400V-3ph-50hz	10	IP55	Class F	-10 + 130
	SPK 5	4,0	7,7	400V-3ph-50hz	10	IP55	Class F	-10 + 130
	SPK 6	4,0	7,7	400V-3ph-50hz	10	IP55	Class F	-10 + 130
	SPK 7	5,5	10,4	400V-3ph-50hz	10	IP55	Class F	-10 + 130
	SPK 8	5,5	10,4	400V-3ph-50hz	10	IP55	Class F	-10 + 130
	SPK 9	5,5	10,4	400V-3ph-50hz	10	IP55	Class F	-10 + 130
	SPK 10	7,5	13,9	400V-3ph-50hz	10	IP55	Class F	-10 + 130
Double Pump Low Available Static Pressure	DPK 1	3,0	6,3	400V-3ph-50hz	10	IP55	Class F	-10 + 130
	DPK 2	4,0	7,7	400V-3ph-50hz	10	IP55	Class F	-10 + 130
	DPK 3	4,0	7,7	400V-3ph-50hz	10	IP55	Class F	-10 + 130
	DPK 4	4,0	7,7	400V-3ph-50hz	10	IP55	Class F	-10 + 130
	DPK 5	5,5	10,4	400V-3ph-50hz	10	IP55	Class F	-10 + 130
	DPK 6	5,5	10,4	400V-3ph-50hz	10	IP55	Class F	-10 + 130
	DPK 7	5,5	10,4	400V-3ph-50hz	10	IP55	Class F	-10 + 130
	DPK 8	5,5	10,4	400V-3ph-50hz	10	IP55	Class F	-10 + 130
	DPK 9	7,5	13,9	400V-3ph-50hz	10	IP55	Class F	-10 + 130

NOTES

- when using mixture of water and glycol please contact the factory as above specification can change

		Pump Motor Power (kW)	Pump Motor Current (A)	Power supply (V-ph-Hz)	PN	Motor Protection	Insulation (Class)	Working Temp. (°C)
Single Pump High Available Static Pressure	SPK 1	3,0	6,3	400V-3ph-50hz	10	IP55	Class F	-10 + 130
	SPK 2	4,0	7,7	400V-3ph-50hz	10	IP55	Class F	-10 + 130
	SPK 3	5,5	10,4	400V-3ph-50hz	10	IP55	Class F	-10 + 130
	SPK 4	5,5	10,4	400V-3ph-50hz	10	IP55	Class F	-10 + 130
	SPK 5	5,5	10,4	400V-3ph-50hz	10	IP55	Class F	-10 + 130
	SPK 6	7,5	13,9	400V-3ph-50hz	10	IP55	Class F	-10 + 130
	SPK 7	7,5	13,9	400V-3ph-50hz	10	IP55	Class F	-10 + 130
	SPK 8	7,5	13,9	400V-3ph-50hz	10	IP55	Class F	-10 + 130
	SPK 9	7,5	13,9	400V-3ph-50hz	10	IP55	Class F	-10 + 130
	SPK 10	11,0	20,2	400V-3ph-50hz	10	IP55	Class F	-10 + 130
Double Pump High Available Static Pressure	DPK 1	4,0	7,7	400V-3ph-50hz	10	IP55	Class F	-10 + 130
	DPK 2	5,5	10,4	400V-3ph-50hz	10	IP55	Class F	-10 + 130
	DPK 3	5,5	10,4	400V-3ph-50hz	10	IP55	Class F	-10 + 130
	DPK 4	7,5	13,9	400V-3ph-50hz	10	IP55	Class F	-10 + 130
	DPK 5	7,5	13,9	400V-3ph-50hz	10	IP55	Class F	-10 + 130
	DPK 6	7,5	13,9	400V-3ph-50hz	10	IP55	Class F	-10 + 130
	DPK 7	7,5	13,9	400V-3ph-50hz	10	IP55	Class F	-10 + 130
	DPK 8	11,0	20,2	400V-3ph-50hz	10	IP55	Class F	-10 + 130
	DPK 9	11,0	20,2	400V-3ph-50hz	10	IP55	Class F	-10 + 130

NOTES

- when using mixture of water and glycol please contact the factory as above specification can change

7 Capacity tables

7 - 1 Cooling Capacity Tables

EWYD460-580BZSS

Ta: Condenser Inlet Air Temperature; CC: Cooling capacity; PI: Power input

Size	ELWT (°C)	Ta (°C)																			
		25				30				35				40				45			
		Rated		Boosted		Rated		Boosted		Rated		Boosted		Rated		Boosted		Rated		Boosted	
		CC	PI	CC	PI	CC	PI	CC	PI	CC	PI	CC	PI	CC	PI	CC	PI	CC	PI	CC	PI
	kW	kW	kW	kW	kW	kW	kW	kW	kW	kW	kW	kW	kW	kW	kW	kW	kW	kW	kW	kW	kW
460	5	466.93	134.45	610.36	206.62	448.11	145.83	554.94	204.22	428.01	158.15	509.5	207.21	433.55	188.32	433.55	188.32	388.26	189.56	388.26	189.56
	7	495.43	137.54	634.64	205	476	149.04	582.51	205.53	455.29	161.49	530.2	204.86	456.07	188.75	456.07	188.75	409.37	189.62	409.37	189.62
	9	524.79	140.76	664.36	206.74	504.72	152.37	610.38	206.88	483.36	164.95	556.15	205.9	478.72	189.13	478.72	189.13	430.55	189.63	430.55	189.63
	11	555.02	144.1	688.46	205.1	534.27	155.83	632.55	204.68	512.22	168.54	582.34	206.87	501.5	189.48	501.5	189.48	451.54	189.56	451.54	189.56
	15	618.03	151.15	742.3	205.13	595.83	163.13	689	207.38	572.33	176.11	628.68	205.02	547.43	190.15	547.43	190.15	493.71	189.38	493.71	189.38
510	5	515.38	148.23	687.56	243.25	494.33	160.89	642.65	252.75	471.52	174.53	587.07	252.47	510.27	234.21	510.27	234.21	459.28	236.09	459.28	236.09
	7	546.71	151.81	722.4	247.32	525.03	164.6	668.92	251.03	501.89	178.44	613.36	251.45	537.2	235.41	537.2	235.41	481.14	233.72	481.14	233.72
	9	578.8	155.51	759.68	252.69	556.49	168.45	696.9	250.17	532.72	182.45	641.32	252.11	558.18	232.18	558.18	232.18	504.23	233.08	504.23	233.08
	11	611.79	159.35	787.68	250.97	588.75	172.43	726.69	250.92	564.25	186.59	667.4	250.73	584.96	233.16	584.96	233.16	529.41	233.6	529.41	233.6
	15	645.67	163.34	817.51	250.37	621.85	176.56	754.52	249.71	596.58	190.88	697.51	252.29	611.79	234.07	611.79	234.07	554.49	234.04	554.49	234.04
520	5	532.61	154.1	718.47	260.97	511.03	167.39	677.37	274.96	487.68	181.72	620.32	274.95	542.77	255.77	542.77	255.77	490.65	258.23	490.65	258.23
	7	564.63	157.82	758.34	267.79	542.34	171.24	705.34	273.42	518.62	185.77	648.28	274.31	571.15	257.24	571.15	257.24	514.01	256.13	514.01	256.13
	9	597.54	161.67	799	274.88	574.56	175.24	734.95	272.9	550.09	189.93	677.97	275.06	595.83	255.51	595.83	255.51	538.71	255.38	538.71	255.38
	11	631.38	165.68	830.72	274.58	607.63	179.4	766.46	273.53	582.39	194.24	705.71	274.07	622.31	255.19	622.31	255.19	565.36	256.11	565.36	256.11
	15	666.08	169.83	860.16	272.75	641.56	183.7	795.97	272.57	615.54	198.71	735.4	274.23	650.91	256.35	650.91	256.35	592.11	256.77	592.11	256.77
580	5	701.65	174.13	893.67	273.95	676.34	188.16	827.49	273.18	649.49	203.34	762.9	272.62	679.66	257.37	679.66	257.37	618.98	257.36	618.98	257.36
	7	616.78	185.36	568.32	172.3	590.96	201.93	544.18	187.77	563.13	219.89	518.55	204.65	491.29	223.05	491.29	223.05	462.24	243.11	462.24	243.11
	9	655.35	189.97	604.93	176.49	628.88	206.72	580.35	192.11	600.47	224.88	553.79	209.1	525.57	227.61	525.57	227.61	495.55	247.77	495.55	247.77
	11	694.58	194.71	642.55	180.84	667.48	211.65	617.07	196.58	638.63	230.04	590.07	213.74	561.02	232.39	561.02	232.39	529.96	252.66	529.96	252.66
	15	734.97	199.65	680.6	185.29	706.94	216.74	654.72	201.21	677.2	235.31	626.98	218.53	597.31	237.35	597.31	237.35	565.52	257.78	565.52	257.78
	13	776.54	204.78	719.8	189.92	747.5	222.04	692.97	205.97	716.76	240.78	664.6	223.46	634.34	242.48	634.34	242.48	601.78	263.08	601.78	263.08
	15	819.23	210.11	760.14	194.73	789.18	227.54	732.33	210.92	757.4	246.46	702.96	228.55	671.86	247.73	671.86	247.73	638.83	268.56	638.83	268.56

NOTES - ANMERKUNGEN - Σημειώσεις - NOTAS - REMARQUES - NOTE - OPMERKINGEN - ПРИМЕЧАНИЯ

- | | |
|--|--|
| <p>1 ELWT = Evaporator Leaving Water Temperature
 ELWT = Verdampfer-Austrittswassertemperatur
 ELWT = Θερμοκρασία νερού εξόδου εξατμιστή
 ELWT = Temperatura del agua de salida del evaporador
 ELWT = Température de l'eau en sortie de l'évaporateur
 ELWT = Temperatura acqua in uscita evaporatore
 ELWT = Temperatuur van uitlaatwater van verdampfer
 ELWT = Температура воды на выходе испарителя</p> | <p>2 Rated / Boosted
 Nominal / Verstärkt
 Ονομαστική / Ενισχυμένη
 Nominal / Aumentado
 Nominale / Accrue
 Nominale / Potenziata
 Nominaal / In boost-modus
 Номинал / С бустером</p> |
|--|--|

8 Pressure drops

8 - 1 Evaporator Pressure Drops

Evaporating Pressure Drops

EWYD-BZSS	250	270	290	320	340	370	380	410	440	460	510	520	580
Cooling Capacity (kW)	254	273	292	324	339	365	382	413	436	457	505	522	583
Water Flow (l/s)	12,12	13,03	13,94	15,46	16,21	17,42	18,25	19,72	20,81	21,83	24,11	24,92	27,87
Pressure Drops (kPa)	37	42	48	53	58	53	57	46	51	61	50	53	65

Water flow and pressure drop referred to nominal condition: evaporator water in/out: 12/7°C – condenser air inlet: 35°C

EWYD-BZSS	250	270	290	320	340	370	380	410	440	460	510	520	580
Heating Capacity (kW)	270	297	324	333	349	379	410	443	463	475	530	558	615
Water Flow (l/s)	12,89	14,18	15,49	15,89	16,66	18,11	19,57	21,15	22,14	22,68	25,33	26,65	29,39
Pressure Drops (kPa)	42	49	58	55	60	57	65	52	57	66	55	60	71

Water flow and pressure drop referred to nominal condition: evaporator water in/out: 12/7°C – condenser air inlet: 35°C

EWYD-BZSL	250	270	290	320	330	360	370	400	430	450	490	510	570
Cooling Capacity (kW)	248	266	291	316	331	355	372	403	425	448	493	510	567
Water Flow (l/s)	11,83	12,70	13,89	15,12	15,83	16,98	17,77	19,28	20,30	21,39	23,56	24,34	27,11
Pressure Drops (kPa)	36	40	48	51	55	50	55	44	48	59	48	51	62

Water flow and pressure drop referred to nominal condition: evaporator water in/out: 12/7°C – condenser air inlet: 35°C

EWYD-BZSL	250	270	290	320	330	360	370	400	430	450	490	510	570
Heating Capacity (kW)	270	297	324	333	349	379	410	443	463	475	530	558	615
Water Flow (l/s)	12,89	14,18	15,49	15,89	16,66	18,11	19,57	21,15	22,14	22,68	25,33	26,65	29,39
Pressure Drops (kPa)	42	49	58	55	60	57	65	52	57	66	55	60	71

Water flow and pressure drop referred to nominal condition: evaporator water in/out: 12/7°C – condenser air inlet: 35°C

Evaporating Pressure Drops

To determinate the pressure drop for different versions or at different working conditions, please refer to the following formula:

$$PD_2 \text{ (kPa)} = PD_1 \text{ (kPa)} \times \left(\frac{Q_2 \text{ (l/s)}}{Q_1 \text{ (l/s)}} \right)^{1.8}$$

where:

- PD₂ Pressure drop to be determinate (kPa)
- PD₁ Pressure drop at nominal condition (kPa)
- Q₂ water flow at new working condition (l/s)
- Q₁ water flow at nominal condition (l/s)

How to use the formula: Example

The unit EWAD650C-SS has been selected for working at the following conditions:

- evaporator water in/out : 11/6°C
- condenser air inlet: 30°C

The cooling capacity at these working conditions is: 265 kW (Rated conditions)

The water flow at these working conditions is: 12.68 l/s (Rated conditions)

The unit EWYD250BZSS at nominal working conditions has the following data:

- evaporator water in/out : 12/7°C
- condenser air inlet: 35°C

The cooling capacity at these working conditions is: 254 kW

The water flow at these working conditions is: 12.12 l/s

The pressure drop at these working conditions is: 37 kPa

The pressure drop at the selected working condition will be:

$$PD_2 \text{ (kPa)} = 37 \text{ (kPa)} \times \left(\frac{12.68 \text{ (l/s)}}{12.12 \text{ (l/s)}} \right)^{1.8}$$

$$PD_2 \text{ (kPa)} = 52 \text{ (kPa)}$$

NOTES

If the calculated evaporator water pressure drop is below 10 kPa or above 100 kPa please contact the factory for dedicated evaporator.

9 Centre of gravity

9 - 1 Centre of Gravity

Dimensions EWYD~BZ

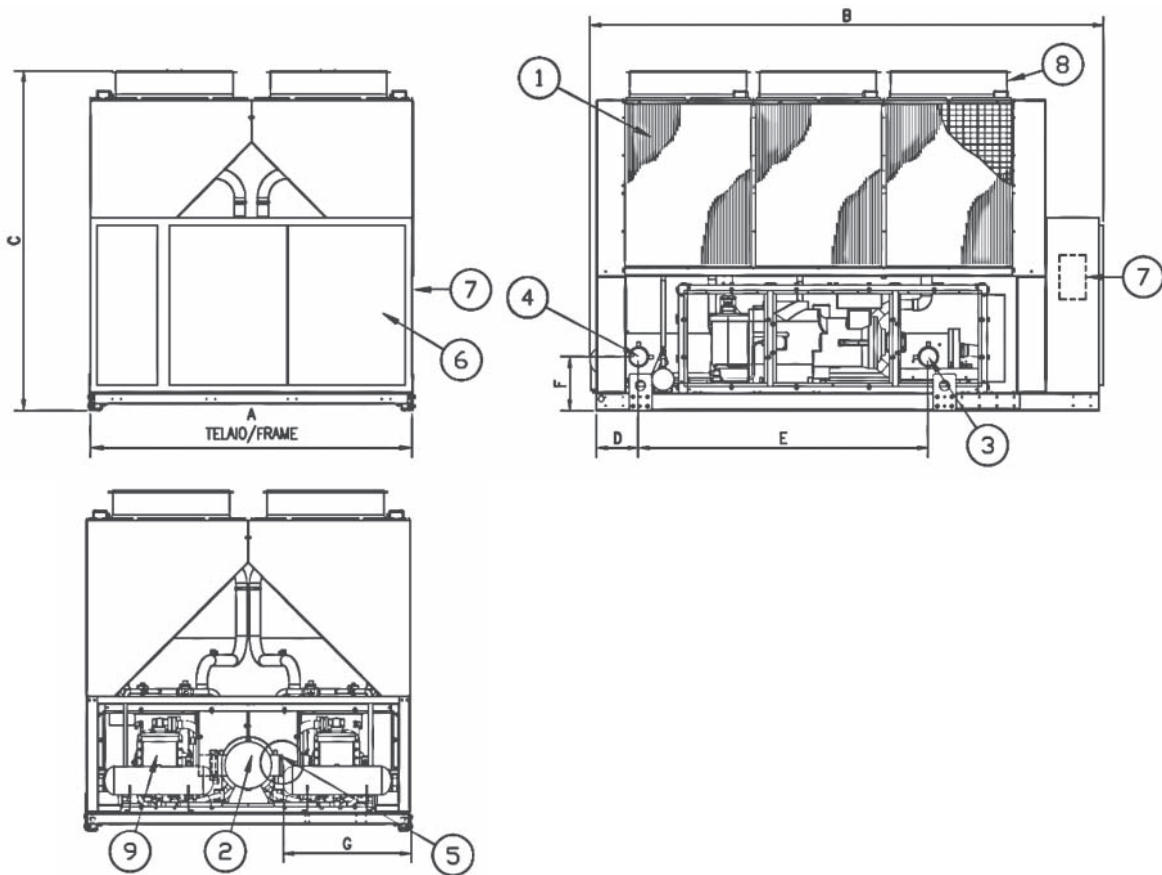

Size		Dimensions							
BZSS	BZSL	A	B	C	D	E	F	G	Fans
250	250	2254	3547	2335	288	2000	449	852	6
270	270	2254	3547	2335	288	2000	449	852	6
290	290	2254	3547	2335	288	2000	449	852	8
320	320	2254	4381	2335	290	2000	449	852	8
340	330	2254	4381	2335	290	2000	449	852	8
370	360	2254	4381	2335	290	2000	449	852	8
380	370	2254	4381	2335	290	2000	449	852	8
410	400	2254	5281	2335	290	2000	449	852	10
440	430	2254	5281	2335	290	2000	449	852	10
460	450	2254	6583	2335	290	2000	449	852	12
510	490	2254	6583	2335	451	1973	503	809	12
520	510	2254	6583	2335	451	1973	503	809	12
580	570	2254	6583	2335	451	1973	503	809	12

NOTES

- 1 Air heat exchanger (condenser – evaporator)
- 2 Water heat exchanger (evaporator – condenser)
- 3 Evaporator water inlet
- 4 Evaporator water outlet
- 5 Victaulic connection
- 6 Electrical control panel
- 7 Slot for power and control connection
- 8 Fan
- 9 Compressor

10 Sound data

10 - 1 Sound Level Data

Sound Levels

EWYD~BZ - Cooling

EWYD-BZSS

Unit size		Sound pressure level at 1 m from the unit in semispheric free field (rif. 2 x 10 ⁻⁵ Pa)									Power	
		63 Hz	125 Hz	250 Hz	500 Hz	1000 Hz	2000 Hz	4000 Hz	8000 Hz	dB(A)	dB(A)	
250+290	Rated	77,0	75,6	75,8	74,9	81,1	69,3	60,7	51,9	82,1	100,5	
	Min	77,0	75,1	73,8	74,0	72,2	66,2	58,9	49,5	75,9	94,4	
	Boost	77,4	78,6	79,1	80,7	79,5	74,7	66,5	58,0	83,1	101,5	
320+380	Rated	77,2	75,8	76,0	75,1	81,3	69,5	60,9	52,1	82,3	101,2	
	Min	77,2	75,3	74,0	74,2	72,4	66,4	59,1	49,7	76,1	95,0	
	Boost	78,5	79,7	80,2	81,8	80,6	75,8	67,6	59,1	84,2	103,1	
410+440	Rated	77,4	76,0	76,2	75,3	81,5	69,7	61,1	52,3	82,5	101,8	
	Min	77,4	75,5	74,2	74,4	72,6	66,6	59,3	49,9	76,3	95,7	
	Boost	78,7	79,9	80,4	82,0	80,8	76,0	67,8	59,3	84,4	103,7	
460+580	Rated	78,6	77,2	77,4	76,5	82,7	70,9	62,3	53,5	83,7	103,6	
	Min	78,6	76,7	75,4	75,6	73,8	67,8	60,5	51,1	77,5	97,4	
	Boost	79,9	81,1	81,6	83,2	82,0	77,2	69,0	60,5	85,6	105,4	

EWYD-BZSL

Unit size		Sound pressure level at 1 m from the unit in semispheric free field (rif. 2 x 10 ⁻⁵ Pa)									Power	
		63 Hz	125 Hz	250 Hz	500 Hz	1000 Hz	2000 Hz	4000 Hz	8000 Hz	dB(A)	dB(A)	
250+290	Rated	76,1	72,4	70,9	69,6	74,2	63,9	55,5	46,3	75,6	94,0	
	Min	76,1	72,5	70,5	69,8	68,6	62,8	55,1	45,7	72,3	90,7	
	Boost	76,2	73,6	72,8	73,7	72,6	67,7	59,5	50,8	76,2	94,6	
320+370	Rated	76,3	72,6	71,1	69,8	74,4	64,1	55,7	46,5	75,8	94,7	
	Min	76,3	72,7	70,7	70,0	68,8	63,0	55,3	45,9	72,5	91,4	
	Boost	76,4	73,8	73,0	73,9	72,8	67,9	59,7	51,0	76,4	95,3	
400+430	Rated	76,5	72,8	71,3	70,0	74,6	64,3	55,9	46,7	76,0	95,3	
	Min	76,5	72,9	70,9	70,2	69,0	63,2	55,5	46,1	72,7	92,0	
	Boost	76,6	74,0	73,2	74,1	73,0	68,1	59,9	51,2	76,6	95,9	
450+570	Rated	77,7	74,0	72,5	71,2	75,8	65,5	57,1	47,9	77,2	97,0	
	Min	77,7	74,1	72,1	71,4	70,2	64,4	56,7	47,3	73,9	93,7	
	Boost	77,8	75,2	74,4	75,3	74,2	69,3	61,1	52,4	77,8	97,6	

NOTES

- Rated (nominal frequency)
- Min (minimum frequency)
- Boost (maximum frequency)

10 Sound data

10 - 1 Sound Level Data

Sound Levels

EWYD-BZ - Heating

EWYD-BZSS

Unit size		Sound pressure level at 1 m from the unit in semispheric free field (rif. 2 x 10 ⁻⁵ Pa)								Power	
		63 Hz	125 Hz	250 Hz	500 Hz	1000 Hz	2000 Hz	4000 Hz	8000 Hz	dB(A)	dB(A)
250÷290	Rated	77.0	75.6	75.8	74.9	81.1	69.3	60.7	51.9	82.1	100.5
	Min	77.0	75.1	73.8	74.0	72.2	66.2	58.9	49.5	75.9	94.4
	Boost	77.4	78.6	79.1	80.7	79.5	74.7	66.5	58.0	83.1	101.5
320÷380	Rated	77.2	75.8	76.0	75.1	81.3	69.5	60.9	52.1	82.3	101.2
	Min	77.2	75.3	74.0	74.2	72.4	66.4	59.1	49.7	76.1	95.0
	Boost	78.5	79.7	80.2	81.8	80.6	75.8	67.6	59.1	84.2	103.1
410÷440	Rated	77.4	76.0	76.2	75.3	81.5	69.7	61.1	52.3	82.5	101.8
	Min	77.4	75.5	74.2	74.4	72.6	66.6	59.3	49.9	76.3	95.7
	Boost	78.7	79.9	80.4	82.0	80.8	76.0	67.8	59.3	84.4	103.7
460÷580	Rated	78.6	77.2	77.4	76.5	82.7	70.9	62.3	53.5	83.7	103.6
	Min	78.6	76.7	75.4	75.6	73.8	67.8	60.5	51.1	77.5	97.4
	Boost	79.9	81.1	81.6	83.2	82.0	77.2	69.0	60.5	85.6	105.4

EWYD-BZSL

Unit size		Sound pressure level at 1 m from the unit in semispheric free field (rif. 2 x 10 ⁻⁵ Pa)								Power	
		63 Hz	125 Hz	250 Hz	500 Hz	1000 Hz	2000 Hz	4000 Hz	8000 Hz	dB(A)	dB(A)
250÷290	Rated	78.1	74.1	72.3	70.8	74.8	65.1	56.8	47.5	76.5	94.9
	Min	78.1	74.1	71.8	70.9	69.9	64.2	56.4	46.9	73.5	91.9
	Boost	78.1	74.9	73.7	74.1	73.2	68.2	60.0	51.2	76.7	95.1
320÷370	Rated	79.5	75.5	74.1	71.5	75.1	67.6	59.6	51.0	77.2	96.1
	Min	78.3	74.3	72.0	71.1	70.1	64.4	56.6	47.1	73.7	92.6
	Boost	78.3	75.1	73.9	74.3	73.4	68.4	60.2	51.4	76.9	95.8
400÷430	Rated	79.7	75.7	74.3	71.7	75.3	67.8	59.8	51.2	77.4	96.7
	Min	78.5	74.5	72.2	71.3	70.3	64.6	56.8	47.3	73.9	93.2
	Boost	78.5	75.3	74.1	74.5	73.6	68.6	60.4	51.6	77.1	96.4
450÷570	Rated	80.9	76.9	75.5	72.9	76.5	69.0	61.0	52.4	78.6	98.4
	Min	79.7	75.7	73.4	72.5	71.5	65.8	58.0	48.5	75.1	94.9
	Boost	79.7	76.5	75.3	75.7	74.8	69.8	61.6	52.8	78.3	98.1

NOTES

- Rated (nominal frequency)
- Min (minimum frequency)
- Boost (maximum frequency)

10 Sound data

10 - 1 Sound Level Data

Sound pressure level correction factors for different distances

EWYD~BZ

EWYD-BZSS / EWYD-BZSL

Unit size		Distance						
BZSS	BZSL	1m	5m	10m	15m	20m	25m	50m
250	250	0,0	6,2	10,3	13,0	15,1	16,8	22,2
270	270	0,0	6,2	10,3	13,0	15,1	16,8	22,2
290	290	0,0	6,2	10,3	13,0	15,1	16,8	22,2
320	320	0,0	5,9	9,9	12,6	14,7	16,4	21,8
340	330	0,0	5,9	9,9	12,6	14,7	16,4	21,8
370	360	0,0	5,9	9,9	12,6	14,7	16,4	21,8
380	370	0,0	5,9	9,9	12,6	14,7	16,4	21,8
410	400	0,0	5,7	9,6	12,3	14,3	16,0	21,4
440	130	0,0	5,7	9,6	12,3	14,3	16,0	21,4
460	450	0,0	5,4	9,3	11,9	13,9	15,6	20,9
510	490	0,0	5,4	9,3	11,9	13,9	15,6	20,9
520	510	0,0	5,4	9,3	11,9	13,9	15,6	20,9
580	570	0,0	5,4	9,3	11,9	13,9	15,6	20,9

11 Installation

11 - 1 Installation Method

1
11

Installation notes

Warning

Installation and maintenance of the unit must be performed only by qualified personnel who have knowledge with local codes and regulations, and experience with this type of equipment. Must be avoided the unit installation in places that could be considered dangerous for all the maintenance operations.

Handling

Care should be taken to avoid rough handling or shock due to dropping the unit. Do not push or pull the unit from anything other than the base frame. Never allow the unit to fall during unloading or moving as this may result in serious damage. To lift the unit, rings are provided in the base frame of the unit. Spreader bar and cables should be arranged to prevent damage to the condenser coil or unit cabinet.

Location

The units are produced for outside installation on roofs, floors or below ground level on condition that the area is free from obstacles for the passage of the condenser air. The unit should be positioned on solid foundations and perfectly level; in the case of installation on roofs or floors, it may be advisable to arrange the use of suitable weight distribution beams. When the units are installed on the ground, a concrete base at least 250 mm wider and longer than the unit's footprint should be laid. Furthermore, this base should withstand the unit weight mentioned in the technical data table.

Space requirements

The units are air-cooled, then it is important to respect the minimum distances which guarantee the best ventilation of the condenser coils. Limitations of space reducing the air flow could cause significant reductions in cooling capacity and an increase in electricity consumption.

To determinate unit placement, careful consideration must be given to assure a sufficient air flow across the condenser heat transfer surface. Two conditions must be avoided to achieve the best performance: warm air recirculation and coil starvation. Both these conditions cause an increase of condensing pressures that result in reductions in unit efficiency and capacity.

Moreover the unique microprocessor has the ability to calculate the operating environment of the air cooled chiller and the capacity to optimize its performance staying on-line during abnormal conditions.

Each side of the unit must be accessible after installation for periodic service. Fig.1 shows you minimum recommended clearance requirements.

Vertical condenser air discharge must be unobstructed because the unit would have its capacity and efficiency significantly reduced.

If the units are positioned in places surrounded by walls or obstacles of the same height as the units, the units should be at least 2500 mm from obstacles (fig.2). In the event the obstacles are higher than the units, the units should be at least 3000 mm from the obstacle (fig.4). Units installed closer than the minimum recommended distance to a wall or other vertical riser may experience a combination of coil starvation and warm air recirculation, thus causing reduction in unit capacity and efficiency reductions. The microprocessor control is proactive in response "of design condition". In the case of single or compounded influences restricting airflow to the unit, the microprocessor will act to keep the compressor(s) running (at reduced capacity) rather than allowing a shut-off on high discharge pressure.

When two or more units are positioned side by side it is recommended that the condenser coils are at least 3600 mm distance from one another (fig.3); strong wind could be the cause of air warm recirculation.

For other installation solutions, consult our technicians.

11 Installation

11 - 1 Installation Method

The above recommended information are representative of general installation. A specific evaluation should be done by contractor depending on the case.

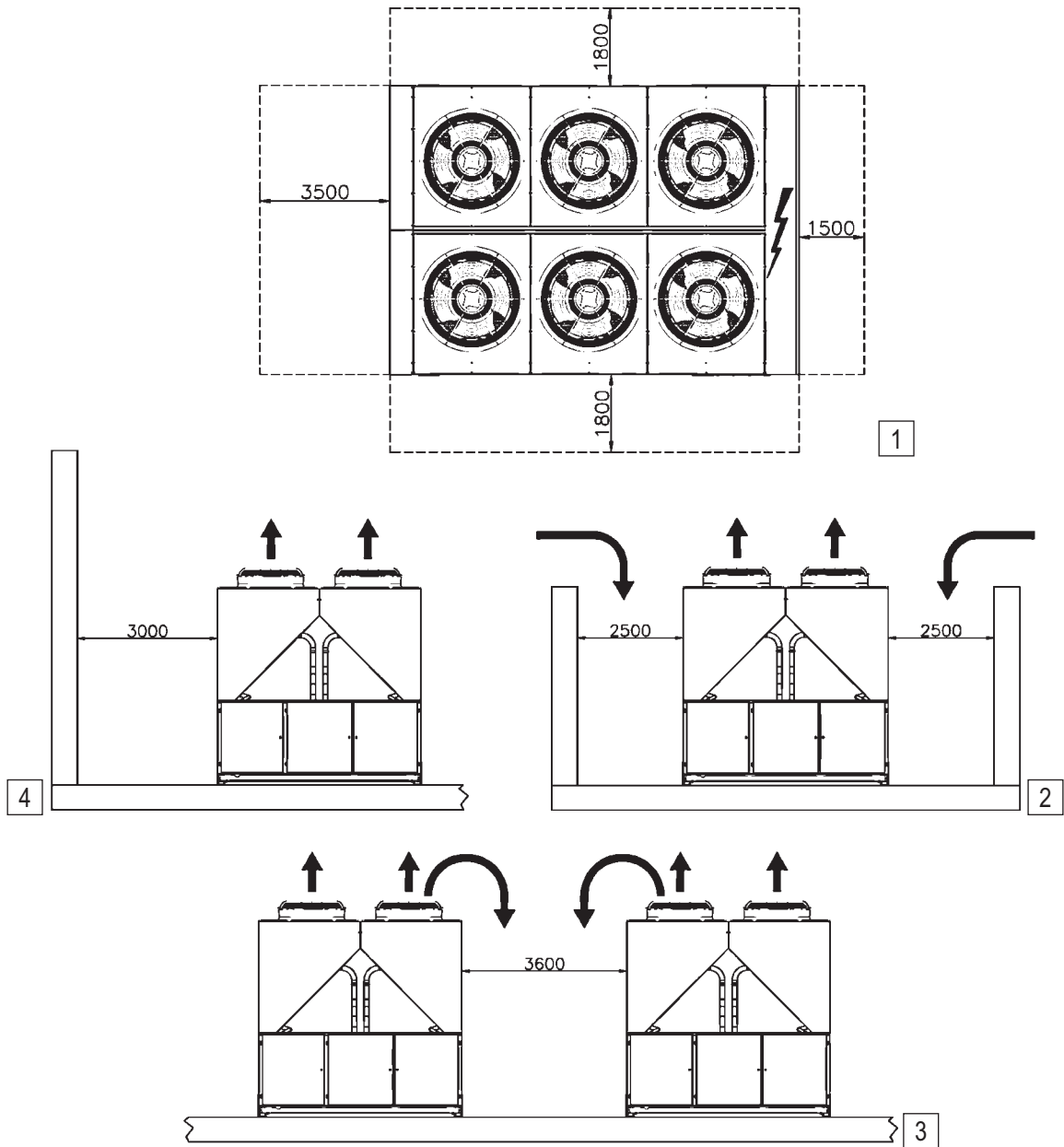

Acoustic protection

When noise level must meet special requirements, it is necessary to pay the maximum attention to ensure the perfect insulation of the unit from the support base by applying appropriate vibration-dampening devices on the unit, on the water pipes and on the electrical connections.

Storage

The environment conditions have to be in the following limits:

- Minimum ambient temperature: -20°C
- Maximum ambient temperature: +57°C
- Maximum R.H.: 95% not condensing

12 Operation range

12 - 1 Operation Range

1
12

Cooling Mode

EWYD~BZSS and EWYD~BZSL

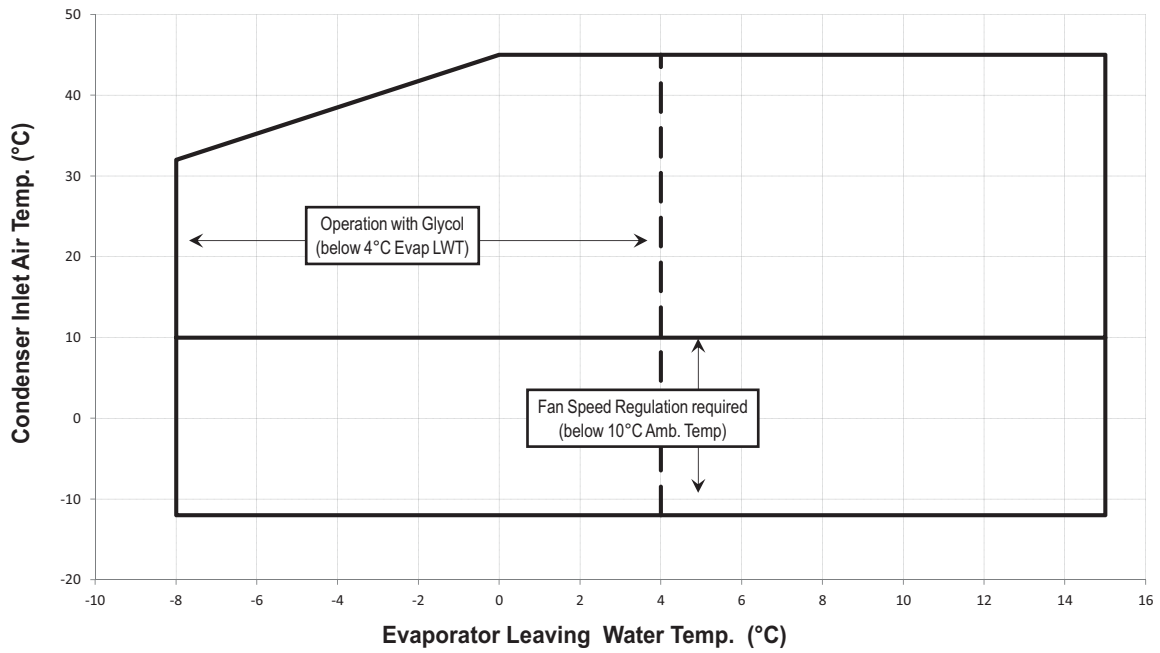

Heating Mode

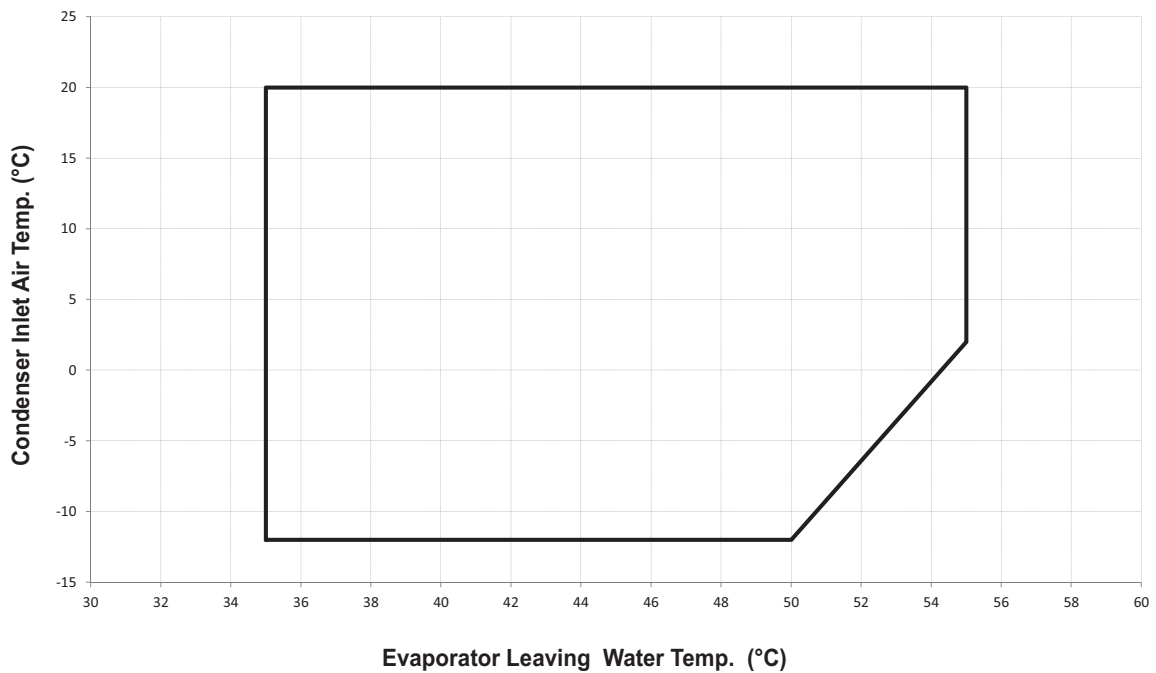

12 Operation range

12 - 1 Operation Range

Table 1 - Water heat exchanger - Minimum and maximum water Δt

Max evaporator water Δt	°C	8
Min evaporator water Δt	°C	4

Note: Table referred to Cooling and Heating Mode

Table 2 - Water heat exchanger - Fouling factors

Fouling factors m ² °C / kW	Cooling capacity correction factor	Power input correction factor	EER correction factor
0,0176	1,000	1,000	1,000
0,0440	0,978	0,986	0,992
0,0880	0,957	0,974	0,983
0,1320	0,938	0,962	0,975

Note: Table referred to Cooling and Heating Mode

Table 3 - Air heat exchanger - Altitude correction factors

Elevation above sea level (m)	0	300	600	900	1200	1500	1800
Barometric pressure (mbar)	1013	977	942	908	875	843	812
Cooling capacity correction factor	1,000	0,993	0,986	0,979	0,973	0,967	0,960
Power input correction factor	1,000	1,005	1,009	1,015	1,021	1,026	1,031

Note: Table referred to Cooling Mode only

Note: Maximum operating altitude is 2000 m above sea level

Note: Contact factory in case the unit has to be installed at altitudes between 1000 and 2000 m above sea level

Table 4.1 - Minimum glycol percentage for low water temperature

Evaporator Leaving Water Temperature (°C)	2	0	-2	-4	-6	-8
Ethylene glycol (%)	10	20	20	20	30	30
Propylene glycol (%)	10	20	20	30	30	30

Note: Table referred to Cooling Mode only

Note: Minimum glycol percentage to be used with evaporator leaving water temperature below 4°C to prevent freezing of water circuit.

Table 4.2 - Minimum glycol percentage for low air ambient temperature

Air Ambient Temperature (°C) (2)	-3	-8	-15	-20
Ethylene glycol (%) (1)	10%	20%	30%	40%
Air Ambient Temperature (°C) (2)	-3	-7	-12	-20
Propylene glycol (%) (1)	10%	20%	30%	40%

Minimum glycol percentage to prevent freezing of water circuit at indicated air ambient temperature

Air ambient temperature do exceed the operating limits of the unit, as protection of water circuit may be needed in winter season at non-working conditions.

Table 5 - Correction factors for low evaporator leaving water temperature

Evaporator Leaving Water Temperature (°C)	2	0	-2	-4	-6	-8
Cooling Capacity	0,842	0,785	0,725	0,670	0,613	0,562
Compressor Power Input	0,950	0,940	0,920	0,890	0,870	0,840

Note: Table referred to Cooling Mode only

Note: Correction factors have to be applied at working conditions: evaporator leaving water temperature 7°C

Table 6 - Correction factors for water and glycol mixture

	Ethylene Glycol (%)	10%	20%	30%	40%	50%
Ethylene Glycol	Cooling Capacity	0,991	0,982	0,972	0,961	0,946
	Compressor Power Input	0,996	0,992	0,986	0,976	0,966
	Flow Rate (Δt)	1,013	1,04	1,074	1,121	1,178
	Evaporator Pressure Drop	1,070	1,129	1,181	1,263	1,308
Propylene Glycol	Cooling Capacity	0,985	0,964	0,932	0,889	0,846
	Compressor Power Input	0,993	0,983	0,969	0,948	0,929
	Flow Rate (Δt)	1,017	1,032	1,056	1,092	1,139
	Evaporator Pressure Drop	1,120	1,272	1,496	1,792	2,128

Note: Table referred to Cooling Mode only

Note: In Heating mode correction factor is 1 at water temperature between operating limits

Note: Contact factory for water temperature out of operating limits

12 Operation range

12 - 1 Operation Range

1
12

How to use the Correction factors proposed in the previous tables

A) Mixture Water and Glycol --- Evaporator leaving water temperature > 4°C

- depending from the type and percentage (%) of glycol filled in the circuit (see table 4.2 and 6)
- multiply the Cooling Capacity, the Compressor Power Input by the Correction factor of Table 6
- starting from this new value of Cooling Capacity, calculate the Flow Rate (l/s) and the Evaporator Pressure Drop (kPa)
- now multiply the new Flow Rate and the new Evaporator Pressure Drop by the Correction Factors of Table 6

Example:

Unit Size: EWYD250BZSS

Mixture:	Water
Working condition:	ELWT 12/7°C – Condenser inlet air temperature 35°C
- Cooling capacity:	254 kW (Rated conditions)
- Power input:	90.3 kW (Rated conditions)
- Flow rate (Δt 5°C):	12.12 l/ss
- Evaporator pressure drop:	37 kPa

Mixture:	Water + Ethylene Glycol 30% (for a winter air temperature up to -15°C)
Working condition:	ELWT 12/7°C - Condenser inlet air temperature 35°C
- Cooling capacity:	254 x 0.972 = 247kW
- Power input:	90.3 x 0.986 = 89.0 kW
- Flow rate (Δt 5°C):	11.80 (referred to 247 kW) x 1.074 : 12.67 l/s
- Evaporator pressure drop:	40 (referred to 12.67 l/s) x 1.181 = 47 kPa

B) Mixture Water and Glycol --- Evaporator leaving water temperature < 4°C

- depending from the type and percentage (%) of glycol filled in the circuit (see table 4.1 and 4.2 and table 6)
- depending from the evaporator leaving water temperature (see table 5)
- multiply the Cooling Capacity, the Compressor Power Input by the Correction factor of Table 5 and Table 6
- starting from this new value of Cooling Capacity, calculate the Flow Rate (l/s) and the Evaporator Pressure Drop (kPa)
- now multiply the new Flow Rate and the new Evaporator Pressure Drop by the Correction Factors of Table 6

Example:

Unit Size: EWYD250BZSS

Mixture:	Water
Working condition:	ELWT 12/7°C – Condenser inlet air temperature 30°C
- Cooling capacity:	265 kW (Rated conditions)
- Power input:	83.3 kW (Rated conditions)
- Flow rate (Δt 5°C):	12.66 l/s
- Evaporator pressure drop:	40 kPa

Mixture:	Water + Glycol 30% (for a low evaporator leaving temperature of -1/-6°C)
Working condition:	ELWT -1/-6°C – Condenser inlet air temperature 30°C
- Cooling capacity:	265 x 0.613 x 0.972 = 158 kW
- Power input:	83.3 x 0.870 x 0.986 = 71.5 kW
- Flow rate (Δt 5°C):	7.54 l/s (referred to 158 kW) x 1.074 = 8.10 l/s
- Evaporator pressure drop:	18 kPa (referred to 8.10 l/s) x 1.181 = 21 kPa

12 Operation range

12 - 1 Operation Range

Water charge, flow and quality

Items ⁽¹⁾⁽⁵⁾	Cooling Water			Cooled Water		Heated water ⁽²⁾				Tendency if out of criteria		
	Circulating System		Once Flow	Circulating water [Below 20°C]	Supply water ⁽⁴⁾	Low temperature		High temperature				
	Circulating water	Supply water ⁽⁴⁾	Flowing water			Circulating water [20°C ~ 60°C]	Supply water ⁽⁴⁾	Circulating water [60°C ~ 80°C]	Supply water ⁽⁴⁾			
pH	at 25°C			6.5 ~ 8.2	6.0 ~ 8.0	6.0 ~ 8.0	6.0 ~ 8.0	7.0 ~ 8.0	7.0 ~ 8.0	7.0 ~ 8.0	7.0 ~ 8.0	Corrosion + Scale
Electrical conductivity	[mS/m] at 25°C	Below 80	Below 30	Below 40	Below 40	Below 30	Below 30	Below 30	Below 30	Below 30	Below 30	Corrosion + Scale
Chloride ion	[μS/cm] at 25°C	(Below 800)	(Below 300)	(Below 400)	(Below 400)	(Below 300)	(Below 300)	(Below 300)	(Below 300)	(Below 300)	(Below 300)	Corrosion + Scale
Sulfate ion	[mgCl ₂ -l]	Below 200	Below 50	Below 50	Below 50	Below 50	Below 50	Below 50	Below 50	Below 50	Below 50	Corrosion
M-alkalinity (pH4.8)	[mgSO ₂ -4l]	Below 200	Below 50	Below 50	Below 50	Below 50	Below 50	Below 50	Below 50	Below 50	Below 50	Corrosion
Total hardness	[mgCaCO ₃ l]	Below 100	Below 50	Below 50	Below 50	Below 50	Below 50	Below 50	Below 50	Below 50	Below 50	Scale
Calcium hardness	[mgCaCO ₃ l]	Below 200	Below 70	Below 70	Below 70	Below 70	Below 70	Below 70	Below 70	Below 70	Below 70	Scale
Silica ion	[mgCaCO ₃ l]	Below 150	Below 50	Below 50	Below 50	Below 50	Below 50	Below 50	Below 50	Below 50	Below 50	Scale
Oxygen	[mgSiO ₂ l]	Below 50	Below 30	Below 30	Below 30	Below 30	Below 30	Below 30	Below 30	Below 30	Below 30	Scale
Particulate size	(mg O ₂ /l)	Below 1.0	Below 1.0	Below 1.0	Below 1.0	Below 1.0	Below 1.0	Below 1.0	Below 1.0	Below 1.0	Below 1.0	Corrosion
Total dissolved solids	(mm)	Below 0.5	Below 0.5	Below 0.5	Below 0.5	Below 0.6	Below 0.5	Below 0.6	Below 0.5	Below 0.6	Below 0.6	Erosion
Ethylene Glycol (weight conc.)	(mg/l)	Below 1000	Below 1000	Below 1000	Below 1000	Below 1001	Below 1000	Below 1001	Below 1000	Below 1001	Below 1001	Erosion
Nitrate ion	(mg NO ₂ -l)	Below 60%	Below 60%	---	Below 60%	Below 60%	Below 60%	Below 60%	Below 60%	Below 60%	Below 60%	--
TOC Total organic carbon	(mg/l)	Below 100	Below 100	Below 100	Below 100	Below 101	Below 100	Below 101	Below 100	Below 101	Below 101	Corrosion
Iron	(mg/l)	Below 1.0	Below 1.0	Below 1.0	Below 1.0	Below 1.0	Below 1.0	Below 1.0	Below 1.0	Below 1.0	Below 1.0	Scale
Copper	[mgFe/l]	Below 1.0	Below 0.3	Below 1.0	Below 1.0	Below 0.3	Below 1.0	Below 0.3	Below 1.0	Below 0.3	Below 0.3	Corrosion + Scale
Sulfite ion	[mgCu/l]	Below 0.3	Below 0.1	Below 1.0	Below 1.0	Below 1.0	Below 1.0	Below 0.1	Below 1.0	Below 0.1	Below 0.1	Corrosion
Ammonium ion	[mgS ₂ -l]	Not detectable	Not detectable	Not detectable	Not detectable	Not detectable	Not detectable	Not detectable	Not detectable	Not detectable	Not detectable	Corrosion
Remaining chloride	[mgNH ₄ l]	Below 1.0	Below 0.1	Below 1.0	Below 1.0	Below 0.3	Below 0.3	Below 0.1	Below 1.0	Below 0.1	Below 0.1	Corrosion
Free carbide	[mgCl/l]	Below 0.3	Below 0.3	Below 0.3	Below 0.3	Below 0.3	Below 0.25	Below 0.3	Below 0.1	Below 0.3	Below 0.3	Corrosion
Stability index	[mgCO ₂ l]	Below 4.0	Below 4.0	Below 4.0	Below 4.0	Below 4.0	Below 0.4	Below 4.0	Below 0.4	Below 4.0	Below 4.0	Corrosion
		6.0 ~ 7.0	---	---	---	---	---	---	---	---	---	Corrosion + Scale

- Names, definitions and units are according to JIS K 0101. Units and figures between brackets are old units published as reference only.
- In case of using heated water (more than 40°C), corrosion is generally noticeable. Especially when the iron materials is in direct contact with water without any protection shields, it is desirable to give the valid measure for corrosion. E.g. chemical measure
- In the cooling water using hermetic cooling tower, close circuit water is according to heated water standard, and scattered water is according to cooling water standard.
- Supply water is considered drink water, industrial water and ground water except for genuine water, neutral water and soft water.
- The above mentioned items are representable items in corrosion and scale cases.
- The limits above have to be considered as a general prescription and can not totally assure the absence of corrosion and erosion. Some particular combinations of elements or the presence of components not listed in the table or factors not considered may trigger corrosion phenomena.

Water content in cooling circuits

The cooled water distribution circuits should have minimum water content to avoid excessive compressors start and stop. In fact, each time the compressor starts up, an excessive quantity of oil goes from the compressor sump and simultaneously there is a rise in the temperature of the compressor motor's stator due to the inrush current during the start-up. To prevent damage to the compressors, it has been envisaged the application of a device to limit frequent stops and restarts.

During the span of one hour there will be no more than 6 starts of the compressor. The plant side should therefore ensure that the overall water content allows a more constant functioning of the unit and consequently greater environmental comfort. The minimum water content per unit should be calculated using this simplified formula:

For 2 compressors unit
M (liters) = (0.1595 x ΔT(°C) + 3.0825) x P(kW)

For 3 compressors unit
M (liters) = (0.0443 x ΔT(°C) + 1.6202) x P(kW)

where:
 M minimum water content per unit expressed in litres
 P Cooling Capacity of the unit expressed in kW
 ΔT evaporator entering / leaving water temperature difference expressed in °C

This formula is valid for:
 - standard microprocessor parameters

For more accurate determination of quantity of water, it is advisable to contact the designer of the plant.

12 Operation range

12 - 1 Operation Range

1
12

Automatic and Manual Boost --- Cooling Mode

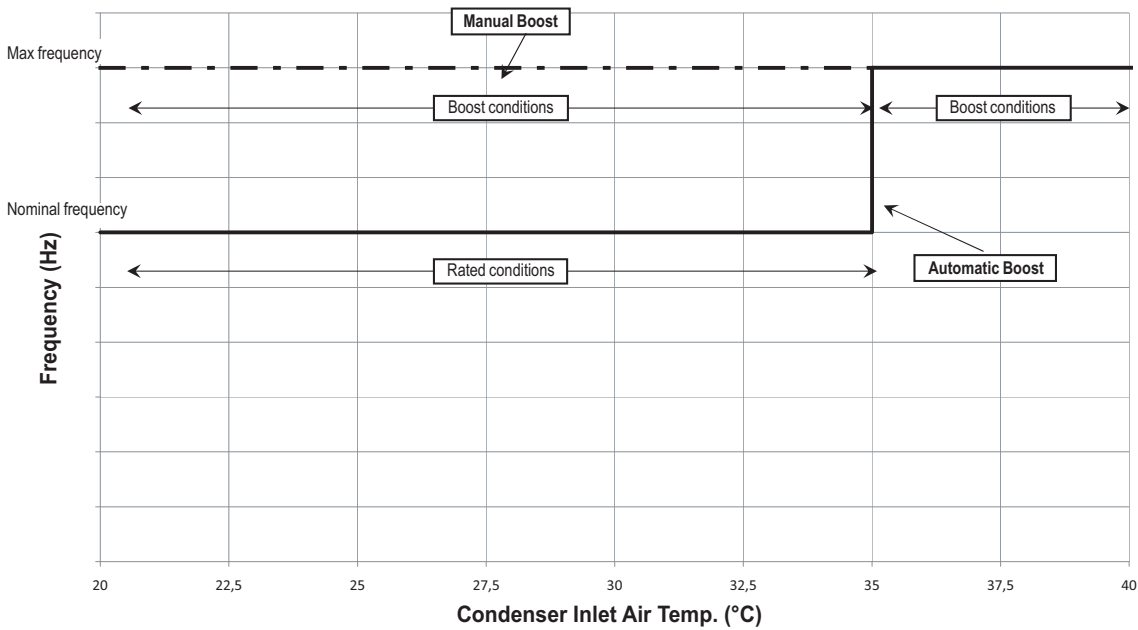

NOTES

1. Automatic boost: unit standard configuration
2. Manual boost: customized configuration by different settings
3. Rated conditions: compressors are working at nominal frequency
4. Boost conditions: compressors are working at the maximum frequency
5. Both automatic and manual boost maximum frequency depends on the maximum current suppliable by the inverter

Automatic and Manual Boost --- Heating Mode

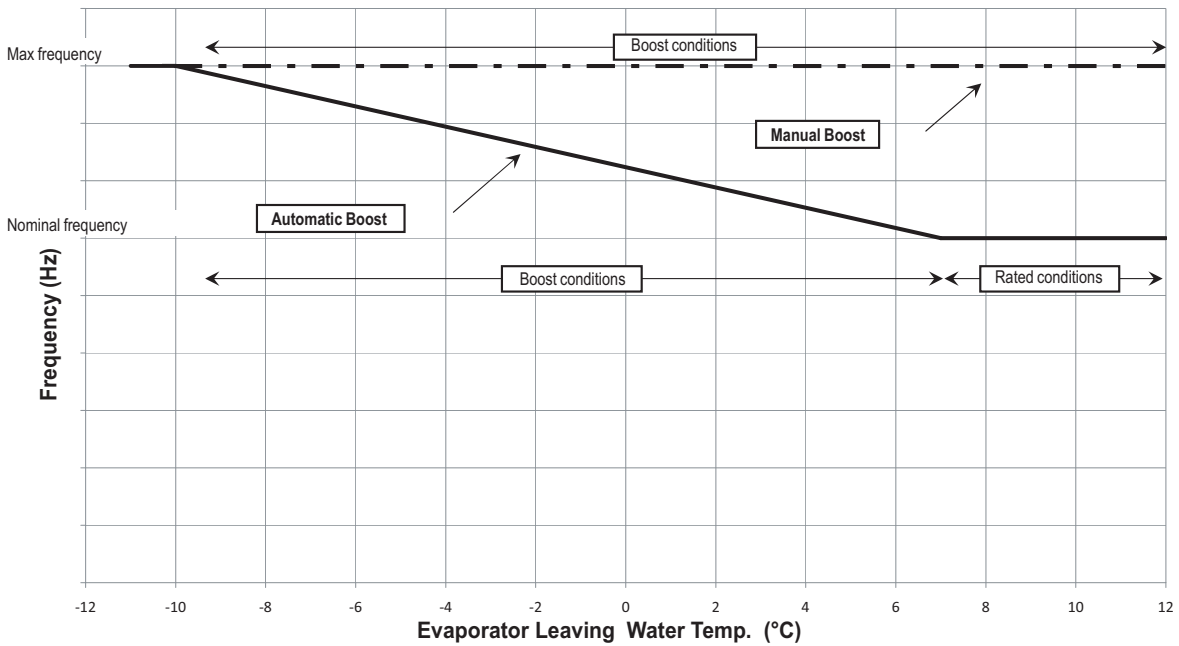

NOTES

1. Automatic boost: unit standard configuration
2. Manual boost: customized configuration by different settings
3. Rated conditions: compressors are working at nominal frequency
4. Boost conditions: compressors are working at the maximum frequency
5. Manual boost: customized configuration by different settings
6. Both automatic and manual boost maximum frequency depends on the maximum current suppliable by the inverter

12 Operation range

12 - 1 Operation Range

Heating Capacity correction factors for different evaporator inlet air temperature and relative humidity conditions

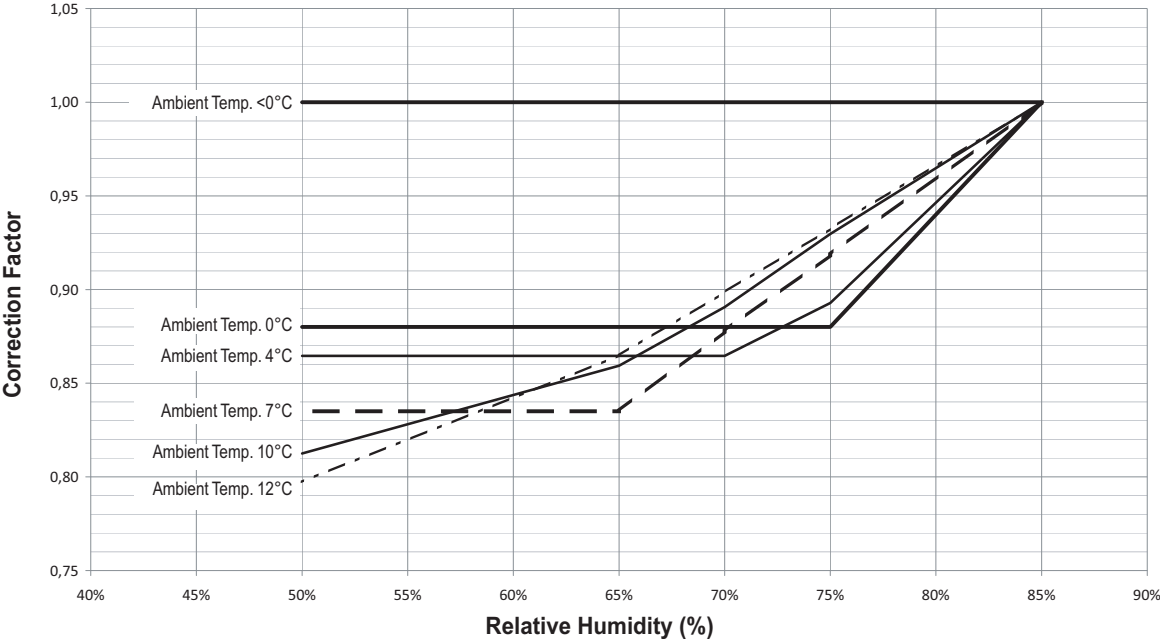

OPL_1a-2-3-4a-5a-6a-7-8_Rev.03_7

12 Operation range

12 - 1 Operation Range

1
12

Integrated Heating Capacity - Automatic Boost

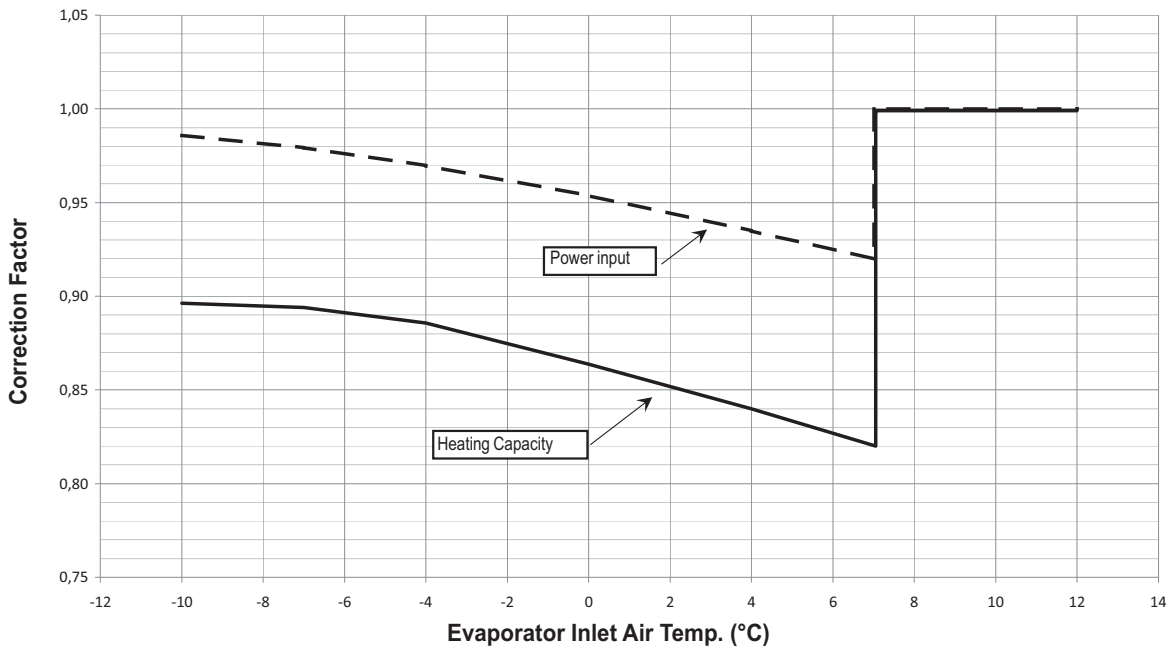

NOTES

- Correction factors to be applied to Standard Ratings in Heating Mode (Relative Humidity: 85% with evaporator inlet air temperature above 0°C ; 100% with evaporator inlet air temperature below 0°C)

Integrated Heating Capacity - Manual Boost

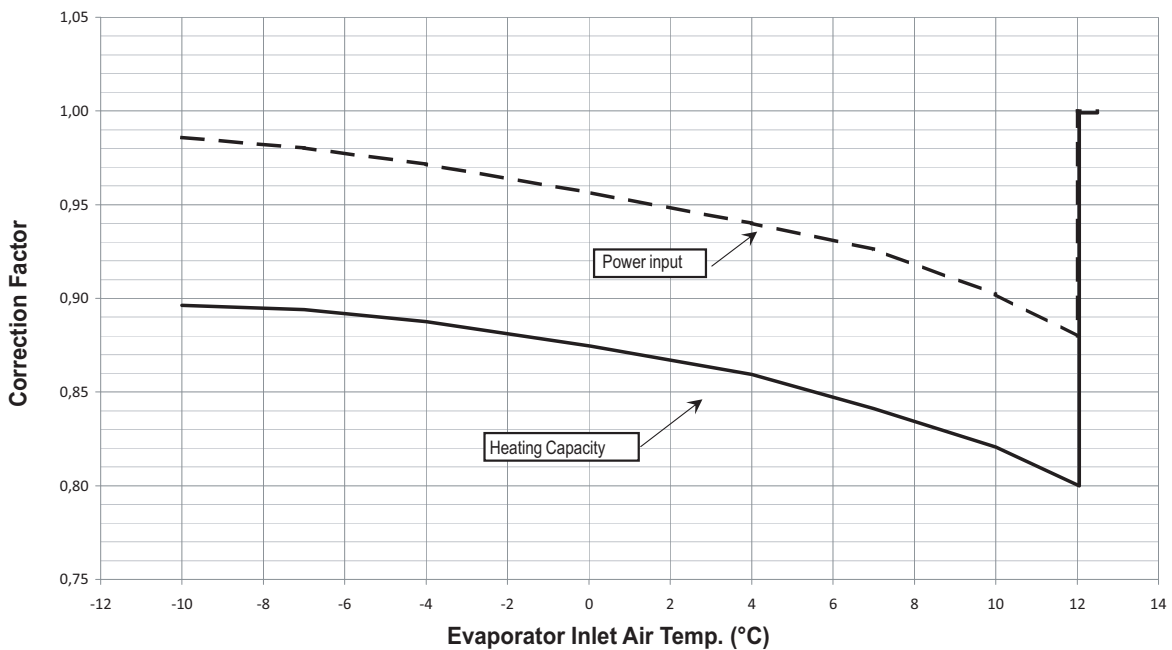

NOTES

- Correction factors to be applied to Standard Ratings in Heating Mode (Relative Humidity: 85% with evaporator inlet air temperature above 0°C ; 100% with evaporator inlet air temperature below 0°C)

13 Specification text

13 - 1 Specification Text

Technical Specification for Air Cooled Screw Chiller

GENERAL

The air to Water Heat Pump will be designed and manufactured in accordance with following European directives:

Rating of chillers	EN 12055
Construction of pressure vessel	97/23/EC (PED)
Machinery Directive	98/37/EC as modified
Low Voltage	2006/95/EC
Electromagnetic Compatibility	2004/108/EC
Electrical & Safety codes	EN 60204-1 / EN 60335-2-40
Manufacturing Quality Stds	UNI – EN ISO 9001:2000
Rating of chillers	EN 12055

The unit will be tested at full load in the factory at the nominal working conditions and water temperatures. Before shipment a full test will be held to avoid any losses.

Heat Pump will be delivered to the job site completely assembled and charged with right refrigerant and oil quantity.

Comply with the manufacturer instructions for rigging and handling equipment.

The unit will be able to start up and operate as standard at full load and outside air temperature from °C to °C with an evaporator leaving fluid temperature between °C and 15 °C

All unit's published performances have to be certified by Eurovent.

REFRIGERANT

Only HFC 134a will be accepted.

PERFORMANCE

- ✓ Number of air to water heat pumps:
- ✓ Cooling capacity for single air to water heat pump: kW
- ✓ Power input for single air to water heat pump in cooling mode: kW
- ✓ Shell & tube heat exchanger entering water temperature in cooling mode: °C
- ✓ Shell & tube heat exchanger leaving water temperature in cooling mode: °C
- ✓ Shell & tube heat exchanger water flow: l/s
- ✓ Nominal outside working ambient temperature in cooling mode: °C

- ✓ Heating capacity for single air to water heat pump: kW
- ✓ Power input for single air to water heat pump in heating mode: kW
- ✓ Shell & tube heat exchanger entering water temperature in heating mode: °C
- ✓ Shell & tube heat exchanger leaving water temperature in heating mode: °C
- ✓ Shell & tube heat exchanger water flow: l/s
- ✓ Nominal outside working ambient temperature in heating mode: °C

- ✓ The unit should work with electricity in range 400 V ±10%, 3ph, 50Hz without neutral and shall only have one power connection point. The control circuit voltage shall be 24 V maximum, supplied by a factory-installed transformer.

UNIT DESCRIPTION

The unit shall include as standard not less than: two or three independent refrigerant circuits, semi-hermetic rotary single screw compressors, air-cooled variable electrical frequency driver for each compressor (VFD), electronic expansion device (EEXV), refrigerant direct expansion shell & tube heat exchanger, air-cooled condenser section, R134a refrigerant, lubrication system, motor starting components, suction line shut-off valve, discharge line shut-off valve, control system and all components necessary for safe and stable unit operation.

The unit will be factory assembled on a robust base-frame made of zinc coated steel, protected by an epoxy paint.

13 Specification text

13 - 1 Specification Text

1
13

NOISE LEVEL AND VIBRATIONS

Sound pressure level at 1 meter distance in free field, semispheric conditions, shall not exceeddB(A). The sound pressure levels must be rated in accordance to ISO 3744.

Other types of rating unacceptable. Vibration level should not exceed 2 mm/s.

DIMENSIONS

Unit dimensions shall not exceed following indications:

- ✓ unit length mm,
- ✓ unit width mm,
- ✓ unit height mm.

HEAT PUMP COMPONENTS

Compressors

- ✓ Semi-hermetic, single-screw type with one main helical rotor meshing with gaterotor. The gaterotor will be constructed of a carbon impregnated engineered composite material. The gaterotor supports will be constructed of cast iron.
- ✓ The oil injection shall be used in order to get high EER (Energy Efficiency Ratio) also at high condensing pressure and low sound pressure levels in each load condition.
- ✓ Refrigerant system differential pressure shall provide oil flow through service replaceable, 0.5 micron, full flow, cartridge type oil filter internal to compressor.
- ✓ Refrigerant system differential pressure shall provide oil injection on all moving compressor parts to correctly lubricate them. Electrical oil pump lubricating system is not acceptable.
- ✓ The compressor's oil cooling must be realized, when necessary, by refrigerant liquid injection. External dedicated heat exchanger and additional piping to carry the oil from the compressor to heat exchanger and viceversa will be not accepted.
- ✓ The compressor shall be provided with an integrated, high efficiency, cyclonic type oil separator and with built-in oil filter, cartridge type.
- ✓ The compressor shall be direct electrical driven, without gear transmission between the screw and the electrical motor.
- ✓ The compressor casing shall be provided with ports to realize economized refrigerant cycles.
- ✓ Shall be present two thermal protection realized by a thermistor for high temperature protection: one temperature sensor to protect electrical motor and another sensor to protect unit and lubricating oil from high discharge gas temperature.
- ✓ The compressor shall be equipped with an electric oil-crankcase heater.
- ✓ Compressor shall be fully field serviceable. Compressor that must be removed and returned to the factory for service shall be unacceptable.

Cooling capacity control system

- ✓ Each unit will have a microprocessor for the control of compressor inverter position and the instantaneous RPM value of the motor.
- ✓ The unit capacity control shall be infinitely modulating, both in cooling and in heating mode, from 100% down to 30% for each compressor (from 100% down to 13% of full load for units with 2 compressors and down to 9% of full load for units with 3 compressors).
- ✓ Step unloading unacceptable because of evaporator leaving water temperature fluctuation and low unit efficiency at partial load.
- ✓ The system shall stage the unit based on the leaving evaporator water temperature that shall be controlled by a PID (Proportional Integral Derivative) loop.
- ✓ Unit control logic shall to manage frequency level of the compressor electric motor to exactly match plant load request in order to keep constant the set point for delivered chilled or hot water temperature.
- ✓ In this operating condition unit control logic shall modulate electrical frequency level in a range lower and upper the nominal electrical network value fixed at 50 Hz.

13 Specification text

13 - 1 Specification Text

- ✓ The microprocessor unit control shall detect conditions that approach protective limits and take self-corrective action prior to an alarm occurring. The system shall automatically reduce chiller capacity when any of the following parameters are outside their normal operating range:
 - o High condenser pressure
 - o Low evaporation refrigerant temperature
 - o High compressor motor amps
- ✓ Air to water heat pump shall be able to deliver heating capacity (with -5°C outside ambient temperature) close to its nominal cooling capacity related at +35°C outside ambient temperature with +7°C for set-point of the leaving evaporator chilled water. In this condition unit shall be able to deliver 45°C hot water.

Unit-Mounted Variable Frequency Driver (VFD) and Electrical Requirement

- ✓ All interconnecting wiring between the VFD and the chiller shall be factory-installed. Customer electrical connection for compressor motor power shall be limited to main power leads to the single point power connection located into electrical panel.
- ✓ The VFD shall be air cooled type. Water cooled design or refrigerant cooled design are not acceptable.
- ✓ The VFD full load efficiency shall meet or exceed 97% at 100% VFD rated capacity.
- ✓ Base motor frequency shall permit motor to be utilized at nameplate voltage. Adjustable frequency range, monitored by unit's microprocessor control, shall permit a stable unit capacity control down to 13% (9% with 3 compressor unit) without hot-gas bypass.
- ✓ Starting current for the compressor shall not exceed nominal compressor load amps.
- ✓ Unit power factor shall be not less than 0.95 on entire unit capacity range, from 100% down to 13% (9% with 3 compressor unit).

Evaporator

- ✓ The units shall be supplied with shell and tubes counter-flow heat exchanger with single refrigerant pass. It will be refrigerant direct expansion type with refrigerant inside the tubes and water outside (shell side). It will include carbon steel tube sheets, with straight copper tubes internally wound for higher efficiencies, expanded on the tube plates.
- ✓ The external shell shall be linked with an electrical heater to prevent freezing down to -28°C ambient temperature, commanded by a thermostat and shall be insulated with flexible, closed cell polyurethane insulation material (10-mm thick).
- ✓ The evaporator will have 2 or 3 circuits, one for each compressor and shall be single refrigerant pass.
- ✓ The water connections shall be VICTAULIC type connections as standard to ensure quick mechanical disconnection between the unit and the hydronic network.
- ✓ Evaporator is manufactured in accordance to PED approval.

Condenser coil

- ✓ The condenser coils are constructed with internally finned seamless copper tubes having a "W" configuration and arranged in a staggered row pattern and mechanically expanded into lanced and rippled aluminium fins with full fin collars for higher efficiencies. The space between the fins are given by a collar that will increase the surface area in connection with the tubes, protecting them from ambient corrosion.
- ✓ The coils will have an integral subcooler circuit that provides sufficient subcooling to effectively eliminate the possibility of liquid flashing and increase the unit's efficiency of 5-7% without increasing in power absorption.
- ✓ The condenser coil shall be leak-tested and submitted to a pressure test with dry air.

Condenser fans

- ✓ The fans used in conjunction with the condenser coils, shall be propeller type with high efficiency design blades to maximize performances and lower noise. The material of the blades is glass reinforced resin and each fan is protected by a guard.
- ✓ The air discharge shall be vertical and each fan must be coupled to the electrical motor. Fan motor will be thermally protected (as standard) by internal thermal motor and protected by circuit breaker installed inside the electrical panel as a standard. The motor will be IP54.
- ✓ They shall have individual overload protection via a disconnect switch.

13 Specification text

13 - 1 Specification Text

1
13

Refrigerant circuit

- ✓ The unit must have refrigerant circuits completely independent of each other with one compressor and one variable electrical frequency driver per circuit (VFD).
- ✓ Each circuit shall include as standard: electronic expansion device piloted by unit's microprocessor control, compressor discharge shut-off valve, suction line shut-off valve, 4-way valve to reverse refrigerant cycle into the unit, liquid line shut-off valve with charging connection, replaceable core filter-drier, sight glass with moisture indicator and insulated suction line.

Condensation control

- ✓ The units will be provided with an automatic control for condensing pressure which ensures the working at low external temperatures down to +10 °C, thanks the ON/OFF of the condenser fans, to maintain condensing pressure. Fan speed control, to allow unit's operation with very low ambient temperature (-18°C), should be available as option.
- ✓ Automatic compressor unloading when abnormal high condensing pressure is detected to prevent the shutdown of the refrigerant circuit (shutdown of the unit) due to a high-pressure fault.

Low Noise unit options (on request)

- ✓ The unit compressors shall be connected with unit's metal baseframe by rubber antivibration supports to prevent the transmission of vibrations to all metal unit structure and so to control the unit noise.
- ✓ The discharge and suction lines shall be provided with mufflers to eliminate vibration and so to reduce the noise unit emission.
- ✓ The chiller shall be provided with an acoustically compressor enclosure. This enclosure shall be realized with a light, corrosion resisting aluminium structure and metal panels. The compressors sound-proof enclosure shall be internally fitted with flexible, multi layer, high density materials. The middle layer is 3 mm, very high density and high efficiency noise reduction material. The enclosure shall be carefully assembled to avoid decreasing of its noise reduction power.
- ✓ The chiller shall be provided with very low speed condenser fans and with an improved condenser section.

13 Specification text

13 - 1 Specification Text

Control panel

- ✓ Field power connection, control interlock terminals, and unit control system should be centrally located in an electric panel (IP 54). Power and starting controls should be separate from safety and operating controls in different compartments of the same panel.
- ✓ Starting will be star/delta type.
- ✓ Power and starting controls should include fuses and contactors for each compressor winding and fan motors. Operating and safety controls should include energy saving control; emergency stop switch; overload protection for compressor motor; high and low pressure cut-out switch (for each refrigerant circuit); anti-freeze thermostat; cut-out switch for each compressor.
- ✓ All of the information regarding the unit will be reported on a display and with the internal built-in calendar and clock that will switch the unit ON/OFF during day time all year long.
- ✓ The following features and functions shall be included:
 - resetting chilled water temperature by controlling the return water temperature or by a remote 4-20 mA DC signal or by controlling the external ambient temperature;
 - soft load function to prevent the system from operating at full load during the chilled fluid pulldown period;
 - password protection of critical parameters of control;
 - start-to-start and stop-to-star timers to provide minimum compressor off-time with maximum motor protection;
 - communication capability with a PC or remote monitoring;
 - discharge pressure control through intelligent cycling of condenser fans;
 - lead-lag selection by manual or automatically by circuit run hours;
 - double set point for brine unit version;
 - scheduling via internal time clock to allow programming of a yearly start-stop schedule accommodating weekends and holidays.

Optional High Level Communications Interface

The controller as a minimum shall be capable of providing the data shown in the above list and document entitled McQuay-comms, using the following options:

- Option A RS485 Serial card
- Option B RS232 Serial card
- Option C LonWorks interface to FTT10A Transceiver
- Option D Bacnet Compatible

TABLE OF CONTENTS

EWYD-BZSL

1	Features	46
2	Specifications	47
	Technical Specifications	47
	Technical Specifications	48
	Electrical Specifications	49
	Electrical Specifications	49
3	Features and advantages	50
	Features and Advantages	50
4	General Characteristics	52
	General characteristics	52
5	Nomenclature	56
	Nomenclature	56
6	Options	57
	Options	57
7	Capacity tables	63
	Cooling Capacity Tables	63
	Heating Capacity Tables	65
8	Pressure drops	66
	Evaporator Pressure Drops	66
9	Centre of gravity	67
	Centre of Gravity	67
10	Sound data	68
	Sound Level Data	68
11	Installation	71
	Installation Method	71
12	Operation range	73
	Operation Range	73
13	Specification text	80
	Specification Text	80

1 Features

- Optimised for use with R-134a
- Ideal solution for commercial comfort cooling and/or heating applications
- EER range up to 2.87
- Standard electronic expansion valve
- DX shell and tube evaporator – one pass refrigerant side to minimize pressure drops
- Low starting current
- No gas boiler required
- Optimised defrost cycles
- Optimum ESEER values
- Partial and total heat recovery option available
- PID microprocessor control
- Power factor up to 0.95
- 2-3 truly independent refrigerant circuits
- Standard operation range down to -12°C

2
1



2 Specifications

2-1 Technical Specifications				EWYD250BZ SL	EWYD270BZ SL	EWYD290BZ SL	EWYD320BZ SL	EWYD330BZ SL	EWYD360BZ SL	EWYD370BZ SL	
Cooling capacity	Nom.			kW	247 (1)	265 (1)	290 (1)	315 (1)	330 (1)	370 (1)	
Heating capacity	Nom.			kW	271 (2)	298 (2)	325 (2)	334 (2)	350 (2)	412 (2)	
Capacity control	Method			Stepless							
	Minimum capacity			%	13						
Power input	Cooling	Nom.		kW	89.5 (1)	99.5 (1)	110 (1)	114 (1)	123 (1)	133 (1)	144 (1)
	Heating	Nom.		kW	91.5 (2)	100 (2)	108 (2)	118 (2)	126 (2)	133 (2)	143 (2)
EER					2.76 (1)	2.66 (1)	2.63 (1)	2.75 (1)	2.67 (1)	2.65 (1)	2.58 (1)
ESEER					4.05	4.04	3.99	4.16	4.05	4.04	4.01
COP					2.96 (2)	2.97 (2)	3.01 (2)	2.83 (2)	2.77 (2)	2.85 (2)	2.89 (2)
IPLV					4.84	4.86	4.80	4.97	4.87		4.84
Casing	Colour			Ivory white							
	Material			Galvanized and painted steel sheet							
Dimensions	Unit	Height	mm		2,335						
		Width	mm		2,254						
		Depth	mm		3,547			4,381			
Weight	Unit			kg	3,750	3,795	3,840	4,210		4,280	4,350
	Operation weight			kg	3,888	3,933	3,978	4,343		4,408	4,478
Water heat exchanger	Type			Single pass shell & tube							
	Water volume			l	138			133		128	
	Nominal water flow	Cooling	l/s		11.83	12.70	13.89	15.12	15.83	16.98	17.77
		Heating	l/s		12.89	14.18	15.49	15.89	16.66	18.11	19.57
	Nominal water pressure drop	Cooling	Heat exchanger	kPa	36	40	48	51	55	50	55
		Heating	Heat exchanger	kPa	42.0	49.0	58.0	55.0	60.0	57.0	65.0
Insulation material			Closed cell								
Air heat exchanger	Type			High efficiency fin and tube type with integral subcooler							
Fan	Quantity			6			8				
	Type			Direct propeller							
	Diameter			mm		800					
	Air flow rate	Cooling	Nom.	l/s	24,432			32,576			
Heating		Nom.	l/s	31,728			42,304				
Fan motor	Drive			DOL							
	Input	Cooling	W		780						
		Heating	W		1,750						
	Speed	Cooling	Nom.	rpm	715						
Heating		Nom.	rpm	920							
Sound power level	Cooling	Nom.		dBA			94.0		94.7		
	Heating	Nom.		dBA			94.9		96.1		
Sound pressure level	Cooling	Nom.		dBA			75.6		75.8		
	Heating	Nom.		dBA			76.5		77.2		
Compressor	Type			Semi-hermetic single screw compressor							
	Quantity			2							
	Oil	Charged volume		l		26					
Operation range	Water side	Cooling	Min.	°CDB		-8					
			Max.	°CDB		15					
		Heating	Min.	°CDB		35					
			Max.	°CDB		55					
	Air side	Cooling	Min.	°CDB		-12					
			Max.	°CDB		45					
Heating		Min.	°CDB		-12						
		Max.	°CDB		20						
Refrigerant	Type			R-134a							
	Charge			kg	88	94	100	118		121	124
	Circuits		Quantity		2						
Piping connections	Evaporator water inlet/outlet (OD)			139.7mm							

2 Specifications

2-2 Technical Specifications					EWYD400BZSL	EWYD430BZSL	EWYD450BZSL	EWYD490BZSL	EWYD510BZSL	EWYD570BZSL	
Cooling capacity	Nom.		kW		402 (1)	423 (1)	446 (1)	491 (1)	508 (1)	564 (1)	
Heating capacity	Nom.		kW		444 (2)	465 (2)	477 (2)	532 (2)	560 (2)	618 (2)	
Capacity control	Method		Stepless								
	Minimum capacity		%		13			9			
Power input	Cooling	Nom.	kW		150 (1)	163 (1)	158 (1)	176 (1)	185 (1)	217 (1)	
	Heating	Nom.	kW		156 (2)	167 (2)	166 (2)	177 (2)	185 (2)	208 (2)	
EER					2.67 (1)	2.60 (1)	2.82 (1)	2.79 (1)	2.75 (1)	2.61 (1)	
ESEER					4.06	4.02	4.18	4.16	4.10	3.98	
COP					2.84 (2)	2.79 (2)	2.87 (2)	3.01 (2)	3.03 (2)	2.97 (2)	
IPLV					4.91	4.86	5.04	5.01	4.96	4.83	
Casing	Colour		Ivory white								
	Material		Galvanized and painted steel sheet								
Dimensions	Unit	Height	mm		2,335						
		Width	mm		2,254						
		Depth	mm		5,281			6,583			
Weight	Unit		kg		4,730	5,525	6,005	6,245			
	Operation weight		kg		4,858	5,765	6,234	6,474	6,463		
Water heat exchanger	Type		Single pass shell & tube								
	Water volume		l		128		240	229		218	
	Nominal water flow	Cooling	l/s		19.28	20.30	21.39	23.56	24.34	27.11	
		Heating	l/s		21.15	22.14	22.68	25.33	26.65	29.39	
	Nominal water pressure drop	Cooling	Heat exchanger	kPa	44	48	59	48	51	62	
		Heating	Heat exchanger	kPa	52.0	57.0	66.0	55.0	60.0	71.0	
Insulation material		Closed cell									
Air heat exchanger	Type		High efficiency fin and tube type with integral subcooler								
Fan	Quantity		10			12					
	Type		Direct propeller								
	Diameter		mm		800						
	Air flow rate	Cooling	Nom.	l/s		40,720			48,864		
		Heating	Nom.	l/s		52,880			63,456		
Fan motor	Drive		DOL								
	Input	Cooling	W		780						
		Heating	W		1,750						
	Speed	Cooling	Nom.	rpm		715					
Heating		Nom.	rpm		920						
Sound power level	Cooling	Nom.	dBA		95.3			97.0			
	Heating	Nom.	dBA		96.7			98.4			
Sound pressure level	Cooling	Nom.	dBA		76.0			77.2			
	Heating	Nom.	dBA		77.4			78.6			
Compressor	Type		Semi-hermetic single screw compressor								
	Quantity		2			3					
	Oil	Charged volume	l		26			39			
Operation range	Water side	Cooling	Min.	°CDB	-8						
			Max.	°CDB	15						
		Heating	Min.	°CDB	35						
			Max.	°CDB	55						
	Air side	Cooling	Min.	°CDB	-12						
			Max.	°CDB	45						
Heating		Min.	°CDB	-12							
		Max.	°CDB	20							
Refrigerant	Type		R-134a								
	Charge		kg		148	177	183	186			
	Circuits	Quantity		2			3				
Piping connections	Evaporator water inlet/outlet (OD)		139.7mm			219.1mm					

2 Specifications

2-3 Electrical Specifications				EWYD250BZ SL	EWYD270BZ SL	EWYD290BZ SL	EWYD320BZ SL	EWYD330BZ SL	EWYD360BZ SL	EWYD370BZ SL
Compressor	Phase			3~						
	Voltage		V	400						
	Voltage range	Min.	%	-10						
		Max.	%	10						
	Maximum running current		A	107				146		
Starting method			VFD driven							
Compressor 2	Maximum running current		A	107				146		
Power supply	Phase			3~						
	Frequency		Hz	50						
	Voltage		V	400						
	Voltage range	Min.	%	-10						
		Max.	%	10						
Unit	Maximum starting current		A	208			252	284	285	284
	Nominal running current (RLA)	Cooling	A	149 (6)	160 (6)	147 (6)	153 (6)	167 (6)	178 (6)	192 (6)
		Heating	A	153 (7)	167 (7)	178 (7)	197 (7)	210 (7)	222 (7)	235 (7)
	Maximum running current		A	238			285	324		
	Max unit current for wires sizing		A	262			314	356		

2-4 Electrical Specifications				EWYD400BZSL	EWYD430BZSL	EWYD450BZSL	EWYD490BZSL	EWYD510BZSL	EWYD570BZSL
Compressor	Phase			3~					
	Voltage		V	400					
	Voltage range	Min.	%	-10					
		Max.	%	10					
	Maximum running current		A	146	176	107	146		
Starting method			VFD driven						
Compressor 2	Maximum running current		A	176		107	146		
Power supply	Phase			3~					
	Frequency		Hz	50					
	Voltage		V	400					
	Voltage range	Min.	%	-10					
		Max.	%	10					
Unit	Maximum starting current		A	319	343	310	380	412	
	Nominal running current (RLA)	Cooling	A	200 (6)	219 (6)	232 (6)	255 (6)	269 (6)	311 (6)
		Heating	A	260 (7)	276 (7)	275 (7)	296 (7)	309 (7)	342 (7)
	Maximum running current		A	362	392	369	447	486	
	Max unit current for wires sizing		A	398	431	406	492	535	

Notes

- (1) Cooling: entering evaporator water temp. 12°C; leaving evaporator water temp. 7°C; ambient air temp. 35°C; full load operation.
- (2) Heating: entering condenser water temp. 40°C; leaving condenser water temp. 45°C; ambient air temp. 7°CDB; unit at full load operation
- (3) Sound pressure levels are measured at entering evaporator water temp. 12°C; leaving evaporator water temp. 7°C; ambient air temp. 35°C; full load operation; Standard: ISO3744
- (4) Allowed voltage tolerance $\pm 10\%$. Voltage unbalance between phases must be within $\pm 3\%$.
- (5) Maximum starting current: starting current of biggest compressor + 75 % of maximum current of the other compressor + fans current for the circuit at 75 %
- (6) Cooling: entering evaporator water temp. 12°C; leaving evaporator water temp. 7°C; ambient air temp. 35°C. Compressor + fans current.
- (7) Heating: entering condenser water temp. 40°C; leaving condenser water temp. 45°C; ambient air temp. 7°CDB, 6°CWB + fans current; installation with 25kA short circuit current
- (8) Maximum running current is based on max compressor absorbed current in its envelope and max fans absorbed current
- (9) Maximum current for wires sizing: (compressors full load ampere + fans current) x 1.1

3 Features and advantages

3 - 1 Features and Advantages

EWYD-BZ

Features and advantages

High part load efficiency

EWYD-BZ is the result of careful design, aimed to optimizing the energy efficiency of the chillers, with the objective of bringing down operating costs and improving installation profitability, effectiveness and economical management.

Per European Seasonal Energy Efficiency Ratio (ESEER), chillers operate at design conditions only three percent of the time. As a result better part load efficiencies are required at part load conditions with a heat pump applications. EWYD-BZ maximize chiller efficiency by optimizing single screw compressor operation dramatically reducing the electric power consumption when the motor speed slows.

Seasonal quietness

Very low noise levels in part load conditions are achieved by varying the fan speed, but especially thanks to the variation of compressor frequency, which ensure the minimum noise level at all the time.

Quick comfort conditions

The ability to vary the output power in direct relation to the cooling requirements of the system, allow the possibility to achieve building comfort conditions much faster at start-up.

Low starting current

No current spikes at start-up. The starting current is always lower than current absorbed in the maximum operating conditions (FLA).

Power factor always > 0.95

EWYD-BZ can operate always > 0.95 power factor, which can allow building owners avoid power factor penalties and decrease electrical losses in cable and transformers.

Redundancy

EWYD-BZ has two or three truly independent refrigerant circuits in every size, in order to assure maximum safety for any maintenance, whether planned or not.

Infinitely capacity control

Cooling capacity control is infinitely variable by means of a Inverter driven screw compressor controlled by microprocessor system. Each unit has infinitely variable capacity control from 100% down to 13,5% (two compressors units) and down to 7% (three compressors). This modulation allows the compressor capacity to exactly match the building cooling load without any leaving evaporator water temperature fluctuation. This chilled water temperature fluctuation is avoided only with a stepless control.

With a compressor load step control in fact, the compressor capacity, at partial loads, will be too high or too low compared to the building cooling load. The result is an increase in chiller energy costs, particularly at the part-load conditions at which the chiller operates most of the time.

Units with stepless regulation offer benefits that the units with step regulation are unable to match. The ability to follow the system energy demand at any time and the possibility to provide steady outlet water temperature without deviations from the set-point, are the two points that allow you to understand how the optimum operating conditions of a system can be met only through the use of a unit with step-less regulation.

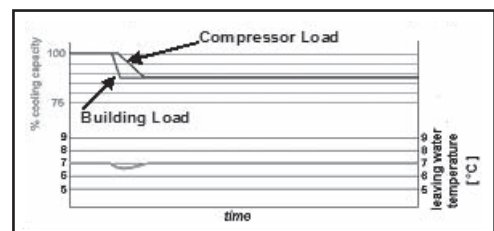

ELWT fluctuation with steps capacity control (4 steps)

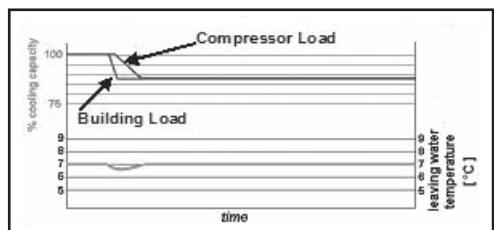

3 Features and advantages

3 - 1 Features and Advantages

EWYD~BZ

Code requirements – Safety and observant of laws/directives

All EWYD~BZ- units are designed and manufactured in accordance with applicable selections of the following:

Rating of chillers	EN 12055
Construction of pressure vessel	97/23/EC (PED)
Machinery Directive	98/37/EC as modified
Low Voltage	2006/95/EC
Electromagnetic Compatibility	2004/108/EC
Electrical & Safety codes	EN 60204-1 / EN 60335-2-40
Manufacturing Quality Stds	UNI – EN ISO 9001:2000

Certifications

All units manufactured by McQuay Italia S.p.A. are CE marked, complying with European directives in force, concerning manufacturing and safety. On request units can be produced complying with laws in force in non European countries (ASME, GOST, etc.), and with other applications, such as naval (RINA, etc.).

Versions

EWYD~BZ is available in the following versions:

S: Standard Efficiency

13 sizes to cover a range from 254 up to 583 kW (Cooling Capacity) and from 270 up to 615 kW (Heating Capacity), with an EER up to 2.87, an ESEER up to 4.29 and a COP up to 3.04.

The EER (Energy Efficiency Ratio) is the ratio of the Cooling Capacity to the Power Input of the unit. The Power Input includes: the power input for operation of the compressor, the power input of all control and safety devices, the power input for fans.

The COP (Coefficient of Performance) is the ratio of the heating capacity to the power input of the unit.

The ESEER (European Seasonal Energy Efficiency Ratio) is a weighed formula enabling to take into account the variation of EER with the load rate and the variation of air inlet condenser temperature.

$$ESEER = A \times EER_{100\%} + B \times EER_{75\%} + C \times EER_{50\%} + D \times EER_{25\%}$$

	A	B	C	D
Coefficient	0.03 (3%)	0.33 (33%)	0.41 (41%)	0.23 (23%)
Air inlet condenser temperature	35°C	30°C	25°C	20°C

Noise Configuration

EWYD~BZ is available in two different noise level configurations:

ST: Standard Noise

Condenser fan rotating at 920 rpm, rubber antivibration on compressor

LN: Low Noise

Condenser fan rotating at 715 rpm (920 rpm in heating mode), rubber antivibration on compressor, compressor sound enclosure.

4 General Characteristics

4 - 1 General characteristics

General characteristics

Cabinet and structure

The cabinet is made of galvanized steel sheet and painted to provide a high resistance to corrosion. Colour Ivory White (Munsell code 5Y7.5/1) (\pm RAL7044). The base frame has eye-hook for lifting the unit with ropes for an easy installation. The weight is uniformly distributed along the profiles of the base and this facilitates the arrangement of the unit.

Screw compressors with integrated oil separator

The compressors are semi-hermetic, single-screw type with gate-rotor (made of carbon impregnated engineered composite material). Each compressor has one inverter managed by the unit microprocessor for infinitely modulating the capacity. An integrated high efficiency oil separator maximises the oil separation.

Start is inverter type.

Ecological HFC 134a refrigerant

The compressors have been designed to operate with R-134a, ecological refrigerant with zero ODP (Ozone Depletion Potential) and very low GWP (Global Warming Potential) that means low TEWI (Total Equivalent Warming Impact).

Evaporator

The units are equipped with a Direct Expansion shell&tube evaporator with copper tubes rolled into steel tubesheets. The evaporators are single-pass on both the refrigerant and water sides for pure counter-flow heat exchange and low refrigerant pressure drops. Both attributes contribute to the heat exchanger effectiveness and total unit's outstanding efficiency.

The external shell is covered with a 10mm closed cell insulation material. Each evaporator has 2 or 3 circuits, one for each compressor and is manufactured in accordance to PED approval. The evaporator water outlet connections are provided with Victaulic Kit (as standard).

Condenser coils

The condenser is manufactured with internally enhanced seamless copper tubes arranged in a staggered row pattern and mechanically expanded into lanced and rippled aluminium condenser fins with full fin collars. An integral sub-cooler circuit provides sub-cooling to effectively eliminate liquid flashing and increase in cooling capacity without increasing the power input.

Condenser coil fans

The condenser fans are propeller type with high efficiency design blades to maximize performances. The material of the blades is glass reinforced resin and each fan is protected by a guard. Fan motor is by circuit breaker installed inside the electrical panel as a standard. The motors are IP54.

Electronic expansion valve

The unit is equipped with the most advanced electronic expansion valves to achieve precise control of refrigerant mass flow. As today's system requires improved energy efficiency, tighter temperature control, wider range of operating conditions and incorporate features like remote monitoring and diagnostics, the application of electronic expansion valves becomes mandatory. Electronic expansion valves possess unique features: short opening and closing time, high resolution, positive shut-off function to eliminate use of additional solenoid valve, continuous modulation of mass flow without stress in the refrigerant circuit and corrosion resistance stainless steel body.

Electronic Expansion Valves are typically working with lower ΔP between high and low pressure side, than a thermostatic expansion valve. The electronic expansion valve allows the system to work with low condenser pressure (winter time) without any refrigerant flow problems and with a perfect chilled water leaving temperature control.

4 General Characteristics

4 - 1 General characteristics

Refrigerant Circuit

Each unit has 2 or 3 independent refrigerant circuits and each one includes:

- Compressor with integrated oil separator
- Air Cooled Condenser
- Electronic expansion valve
- Evaporator
- Discharge line shut off valve
- Liquid line shut off valve
- Suction line shut off valve
- Sight glass with moisture indicator
- Filter drier
- Charging valves
- High pressure switch
- High and low pressure transducers

Electrical control panel

Power and control are located in two sections of the main panel that is manufactured to ensure protection against all weather conditions. The electrical panel is IP54 and (when opening the doors) internally protected with Plexiglas panel against possible accidental contact with electrical components (IP20). The main panel is fitted with a main switch interlocked door.

Power Section

The power section includes circuit breaker, compressors inverters, fans contactors, fans thermal overload relays, fans and control circuit transformer.

MicroTech II controller

MicroTech II C Plus controller is installed as standard; it can be used to modify unit set-points and check control parameters. A built-in display shows machine's operating status, programmable values, set-points, like temperatures and pressures of water, refrigerant and air. Device controls maximise the chiller energy efficiency and the reliability. A sophisticated software with predictive logic, select the most energy efficient combination of compressors, EEXV and condenser fans to keep stable operating conditions and maximise energy efficiency. The compressors are automatically rotated to ensure equal operating hours. MicroTech II C Plus protects critical components in response to external signals from its system sensors measuring: motor temperatures, refrigerant gas and oil pressures, correct phase sequence and evaporator.

Control section - main features

- Management of the compressor capacity, Inverter, slide and fans modulation.
- Chillers enabled to work in partial failure condition.
- Full routine operation at condition of:
 - high ambient temperature value,
 - high thermal load,
 - high evaporator entering water temperature (start-up).
- Display of evaporator entering/leaving water temperature.
- Display of condensing-evaporating temperature and pressure, suction and discharge superheat for each circuit.
- Leaving water cooled temperature regulation. Temperature tolerance = 0,1°C.
- Compressors and evaporator pumps hours counter.
- Display of Status Safety Devices.
- Start up numbers and compressors working hours equalization.
- Optimized management of compressors load.
- Fans management according to condensing pressure.
- Automatic re-start in case of power supply interruption (adjustable).
- Soft Load.
- Start at high evaporator water temperature.
- Return Reset.
- AOT Reset (optional).
- Set point Reset (optional).

GNC_1a-2a-3a-4a-5c_Rev.03_2a

4 General Characteristics

4 - 1 General characteristics

Safety device / logic for each refrigerant circuit

- High pressure (pressure switch).
- Low pressure (transducer).
- Condensation fan Magneto-thermal.
- High Discharge Temperature on the compressor.
- Phase Monitor.
- Low pressure ratio.
- High oil pressure drop.
- Low oil pressure.

System security

- Phase monitor.
- Freeze protection.

Regulation type

Proportional + integral + derivative regulation on the leaving water evaporator output probe.

Condensing pressure

The condensation can be carried out according to temperature or pressure or pressure ratio. The fans can be managed according to a 0/10 V modulating signal.

Intelligent Compressor Start Mode

Control software includes an intelligent compressor start mode that unloads the first compressor to 75% during the start of the second one, in order to reduce inrush current.

MicroTech II C Plus terminal

MicroTech II C Plus built-in terminal has the following features.

- 4-lines by 20-character liquid crystal display back lighting.
- Key-pad consisting of 6 keys.
- Memory to protect the data.
- General faults alarm relays.
- Password access to modify the setting.
- Service report displaying all running hours and general conditions.
- Alarm history memory to allow an easy fault analysis.

Supervising systems (on request)

MicroTech II C Plus remote control

MicroTech II C Plus is able to communicate to BMS (Building Management System) based on the most common protocols as:

- CARELNative
- ModbusRTU
- LonWorks, now also based on the international 8040 Standard Chiller Profile and LonMark Technology
- BacNet BTP certified over IP and MS/TP (class 4)
- Ethernet TCP/IP and SNMP.

Standard accessories (supplied on basic unit)

Inverter compressor starter – For low inrush current and reduced starting torque.

Double set-point – Dual leaving water temperature set-points.

Fans circuit breaker thermal overload relays – Safety devices against fan motor overloading and short circuit in addition to the normal protection envisaged by the electrical windings.

Phase monitor – The phase monitor controls that phases sequence is correct and controls phase loss.

Evaporator Victaulic kit on water connection – Hydraulic joint with gasket for an easy and quick water connection.

GNC_1a-2a-3a-4a-5c_Rev.03_3a

4 General Characteristics

4 - 1 General characteristics

10mm evaporator insulation

Evaporator electric heater – Electric heater controlled by a thermostat to protect the evaporator from freezing down to -28°C ambient temperature, providing the power supply is on.

Electronic expansion valve

Discharge line shut off valves – Installed on the discharge port of the compressor to facilitate maintenance operation.

Suction line shut off valve – Installed on the suction port of the compressor to facilitate maintenance operation.

Outside ambient temperature sensor and reset of leaving water temperature set-point

Compressor hour run meter

General fault – Alarm relay.

Main switch interlock door

Options (on request)

Partial heat recovery – Produced with plate to plate heat exchangers installed between the compressor discharge and the condenser coil, allowing to produce hot water.

Brine version – Allows the unit to operate down to -8°C leaving liquid temperature (antifreeze required).

Under/Over Voltage – This device control the voltage value of power supply and stop the chiller if the value exceeds the allowed operating limits.

Energy Meter – This device allows to measure the energy absorbed by the chiller during its life. It is installed inside the control box mounted on a DIN rail and show on a digital display: Line-to-Line Voltage, Phase and Average Current, Active and Reactive Power, Active Energy, Frequency.

Current limit – To limit maximum absorbed current of the unit whenever is required

20mm evaporator insulation

Fan Silent Mode - The microprocessor clock switches the fan at low speed according to the client setting (i.e. Night & Day), providing that the ambient temperature/condensing pressure is allowing the speed change. It allows a perfect condensing control down to -10°C.

Fan speed regulation – To control the fan speed revolution for smooth operating control of the unit. This option improves the sound level of the unit during low ambient temperature operation.

Condenser coil guards

Cu-Cu condensing coils – To give better protection against corrosion by aggressive environments.

Cu-Cu-Sn condensing coils – To give better protection against corrosion in aggressive environments and by salty air.

Alucoat condensing coils – Fins are protected by a special acrylic paint with a high resistance to corrosion.

Evaporator Flow switch – Supplied separately to be wired and installed on the evaporator water piping (by the customer).

High pressure side manometers

High pressure side manometers

Low pressure side manometers

Set-point reset – The leaving water temperature set-point can be overwritten with the following options: 4-20mA from external source (by user); outside ambient temperature; evaporator water temperature Δt .

Demand limit – User can limit the load of the unit by 4-20mA signal or by network system

Alarm from external device – Microprocessor is able to receive an alarm signal from an external device (pump etc...). User can decide if this alarm signal will stop or not the unit.

Kit container

Rubber type antivibration mounts – Supplied separately, these are positioned under the base of the unit during installation. Ideal to reduce the vibrations when the unit is floor mounted.

Spring type antivibration mounts – Supplied separately, these are positioned under the base of the unit during installation. Ideal for dampening vibrations for installation on roofs and metallic structures.

Water circulation pump (low or high lifting) – Not available for 250+290 BZSL units. Hydronic kit consists of: single direct driven centrifugal pump, water filling system with pressure gauge, safety valve, drain valve. The motor pump is protected by a circuit breaker installed in control panel. The kit is assembled and wired to the control panel. The pipe and pump are protected from freezing with an additional electrical heater.

Two water circulation pumps (low or high lifting) – Not available for 250+290 BZSL units. Hydronic kit consists of: twin direct driven centrifugal pumps, water filling system with pressure gauge, safety valve, drain valve. The motor pump is protected by a circuit breaker installed in control panel. The kit is assembled and wired to the control panel. The pipe and pumps are protected from freezing with an additional electrical heater.

Witness test – Every unit is always tested at the test bench prior to the shipment. On request, a second test can be carried out, at customer's presence, in accordance with the procedures indicated on the test form. (Not available for units with glycol mixtures).

Double pressure relief valve with diverter

GNC_1a-2a-3a-4a-5c_Rev.03_4a

5 Nomenclature

5 - 1 Nomenclature

2
5

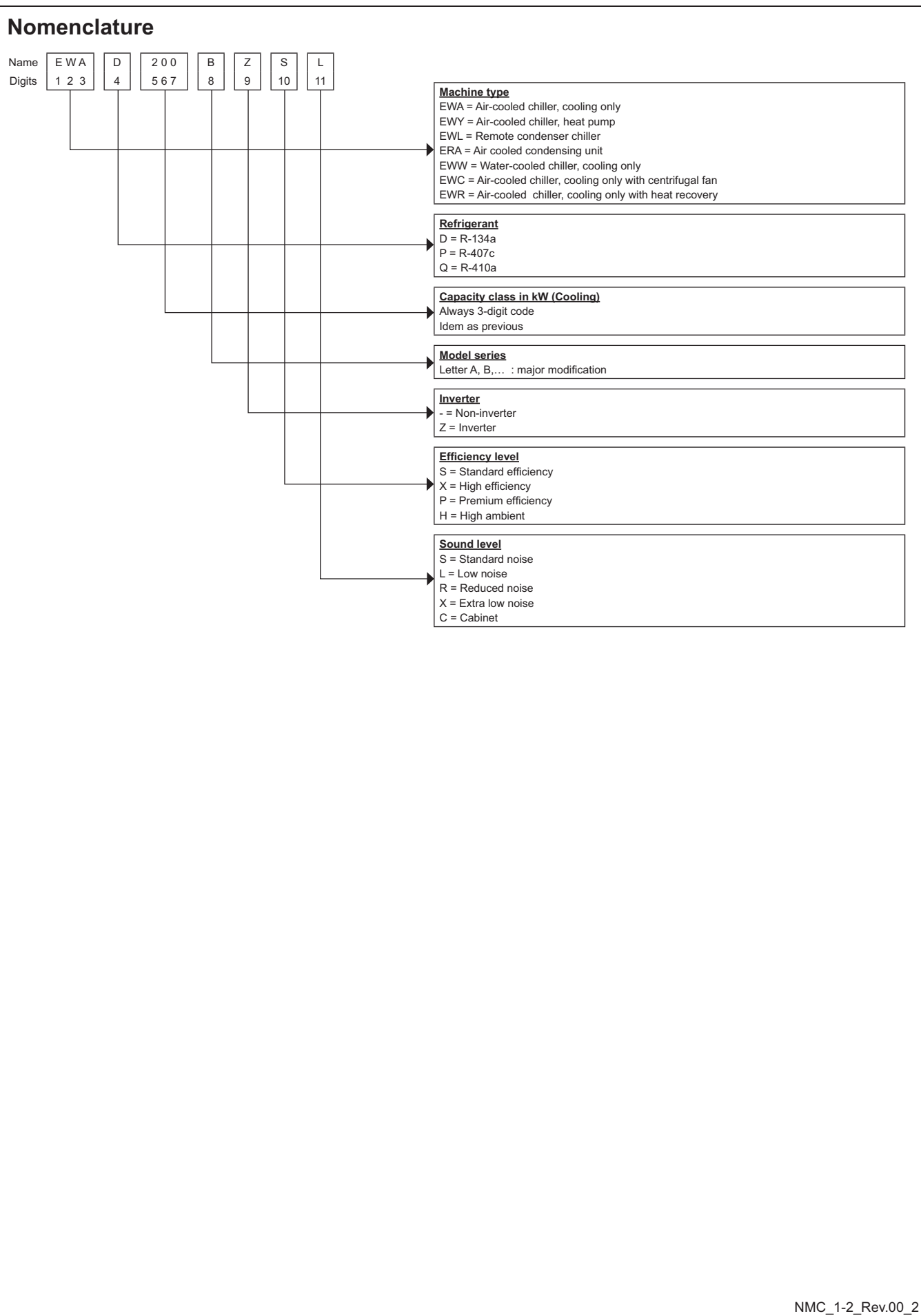

6 Options

6 - 1 Options

EWYD-BZ

EWYD-BZSS	EWYD-BZSL	Evaporator Leaving Temperature 7°C - Δt 5°C Condenser Inlet Air 35°C	1Partial Heat Recovery Leaving Water Temperature (°C)			Partial Heat Rrecovery LWT 45°C	
			45 (Δt=5°C) Hc (kW)	50 (Δt=5°C) Hc (kW)	55 (Δt=5°C) Hc (kW)	Water Flow l/s	Pressure Drops kPa
250	250		74.3	67.8	57.9	3.55	5
270	270		80.9	76.1	65.4	3.87	6
290	290		88.5	85.2	73.5	4.23	7
320	320		93.5	88.2	75.7	4.47	8
340	330		99.4	91.9	78.6	4.75	7
370	360		106	100	85.7	5.06	8
380	370		115	109	94.2	5.49	9
410	400		117	107	96.0	5.60	22
440	130		125	113	102	5.95	24
460	450		133	128	110	6.34	15
510	490		144	135	115	6.86	18
520	510		149	138	118	7.12	14
580	570		173	164	141	8.24	18

OPT_1-2-3-4_Rev.00_1

Partial Heat Recovery Pressure Drops

To determine the pressure drop for different versions or at different working condition, please refer to the following formula:

$$PD_2 \text{ (kPa)} = PD_1 \text{ (kPa)} \times \left(\frac{Q_2 \text{ (l/s)}}{Q_1 \text{ (l/s)}} \right)^{1.80}$$

where:

- PD₂ Pressure drop to be determinate (kPa)
- PD₁ Pressure drop at nominal condition (kPa)
- Q₂ water flow at new working condition (l/s)
- Q₁ water flow at nominal condition (l/s)

How to use the formula: Example

The unit EWYD250BZSS has been selected for working at the following conditions:
 Partial heat recovery leaving water temperature 50/55°C
 The heating capacity at these working conditions is: 57.9 kW
 The water flow at these working conditions is: 2.77 l/s

The unit EWAD650C-SS at nominal working conditions has the following data:
 - Partial heat recovery leaving water temperature 40/45°C
 - condenser air inlet: 35°C
 The heating capacity at these working conditions is: 74.3 kW
 The water flow at these working conditions is: 3.55 l/s
 The pressure drop at these working conditions is: 5 kPa

The pressure drop at the selected working condition will be:

$$PD_2 \text{ (kPa)} = 5 \text{ (kPa)} \times \left(\frac{2.77 \text{ (l/s)}}{3.55 \text{ (l/s)}} \right)^{1.80}$$

$$PD_2 \text{ (kPa)} = 3 \text{ (kPa)}$$

OPT_1-2-3-4-5_Rev.00_2

6 Options

6 - 1 Options

2
6

Water Pump Kit - Discharge Head

Single Pump (2 poles) - Low Available external static pressure

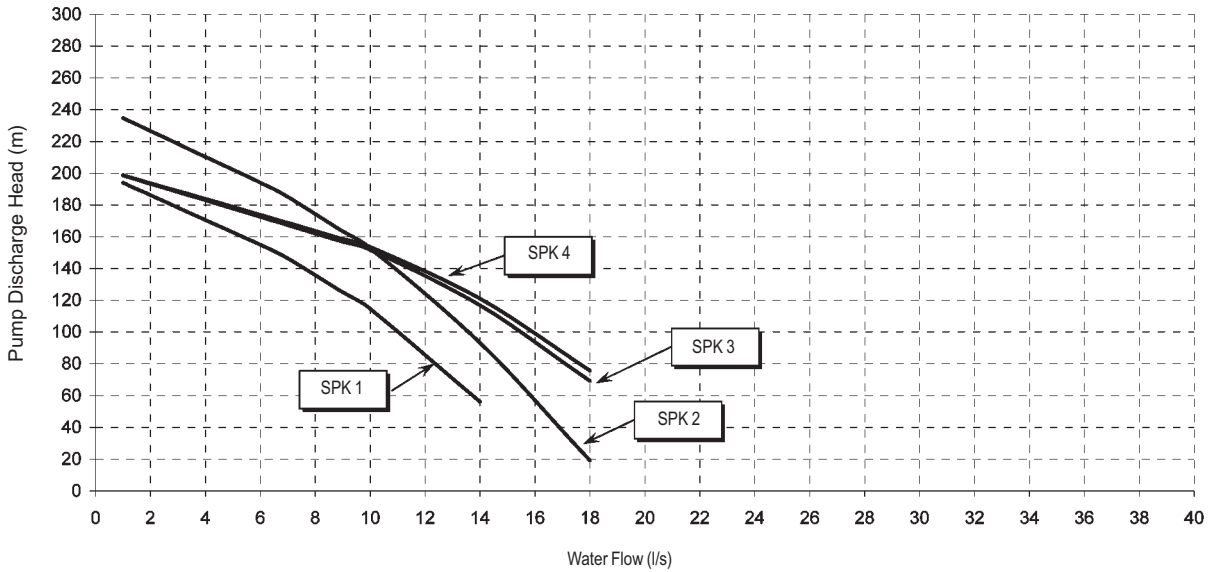

NOTES

- when using mixture of water and glycol please contact the factory as above specification can change

Single Pump (2 poles) - Low Available external static pressure

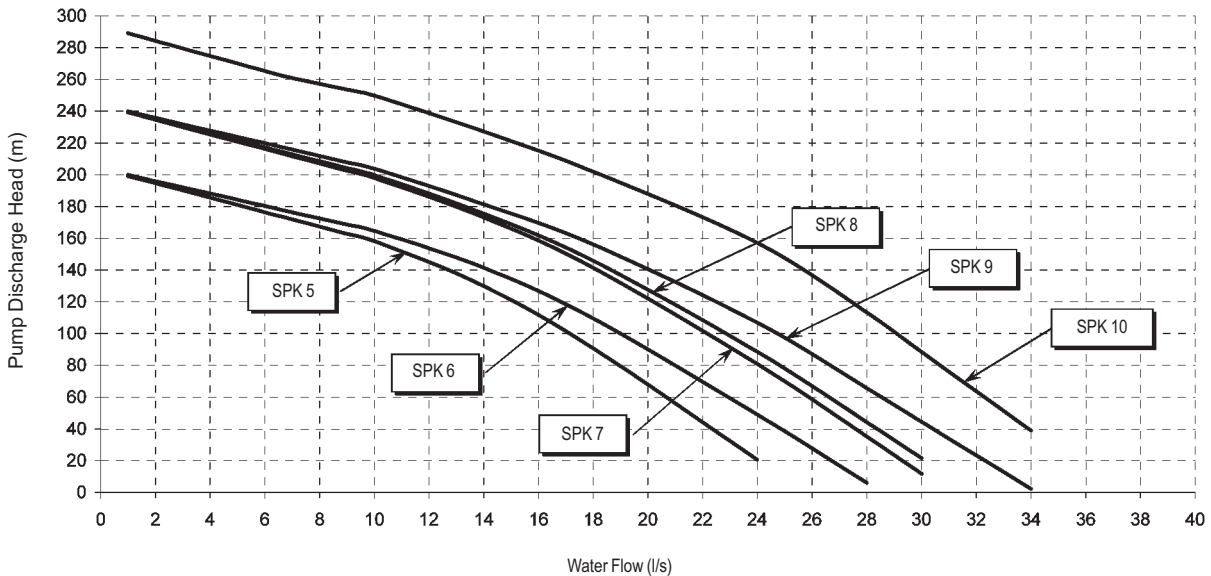

NOTES

- when using mixture of water and glycol please contact the factory as above specification can change

Pump Kit	SPK1	SPK2	SPK3	SPK4		SPK5		SPK6	SPK7	SPK8	SPK9	SPK10	
Size EWYD-BZSS	250	270	290	320	340	370	380	410	440	460	510	520	580
Size EWYD-BZSL	250	270	290	320	330	360	370	400	430	450	490	510	570

6 Options

6 - 1 Options

Water Pump Kit - Discharge Head

Twin Pump (2 poles) - Low Available external static pressure

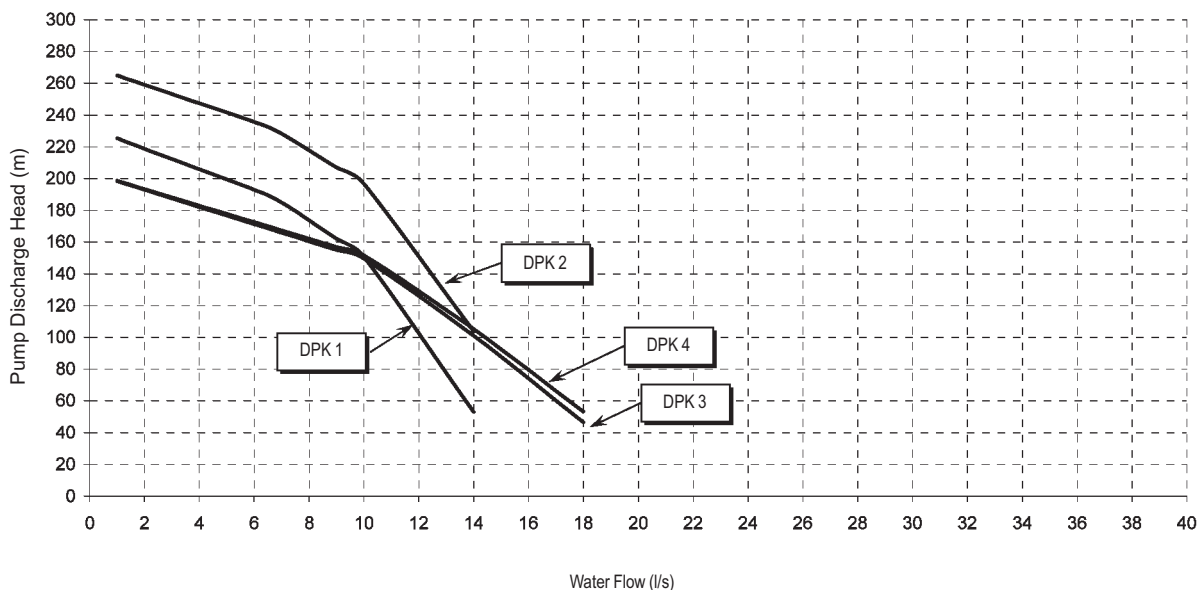

NOTES

- when using mixture of water and glycol please contact the factory as above specification can change

Twin Pump (2 poles) - Low Available external static pressure

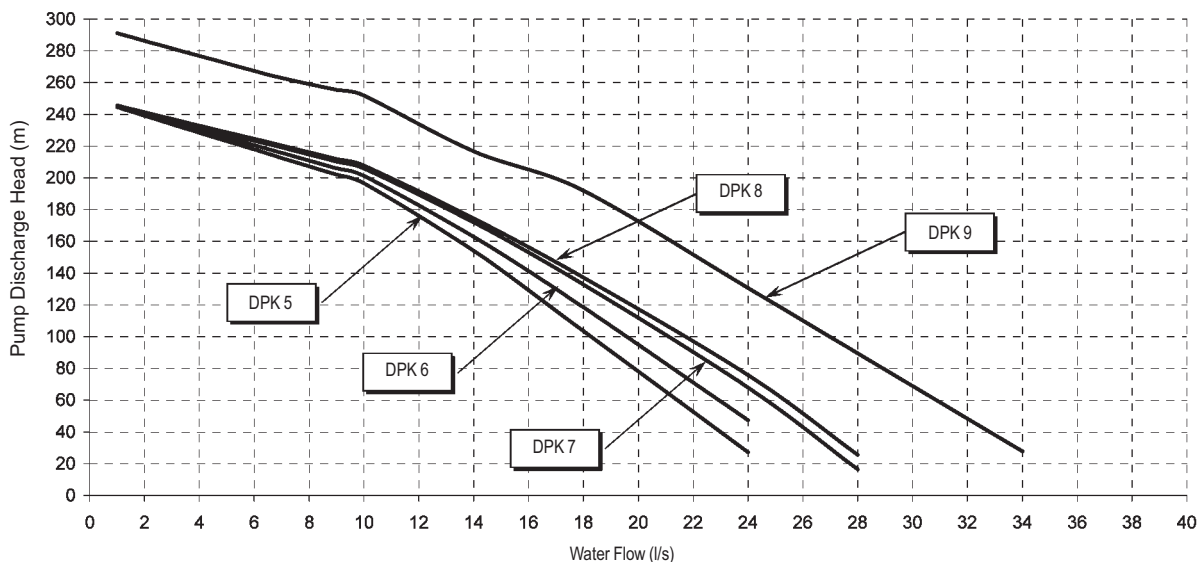

NOTES

- when using mixture of water and glycol please contact the factory as above specification can change

Pump Kit	DPK1	DPK2	DPK3	DPK4	DPK5	DPK6	DPK7	DPK8	DPK9				
Size EWYD-BZSS	250	270	290	320	340	370	380	410	440	460	510	520	580
Size EWYD-BZSL	250	270	290	320	330	360	370	400	430	450	490	510	570

6 Options

6 - 1 Options

2
6

Water Pump Kit - Discharge Head

Single Pump (2 poles) - High Available external static pressure

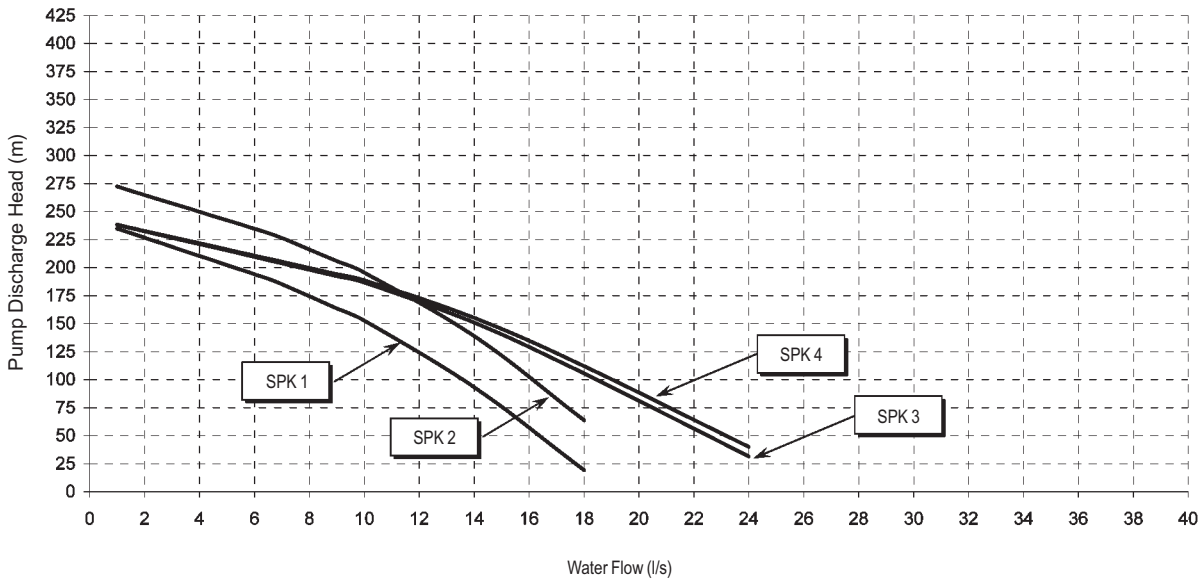

NOTES

- when using mixture of water and glycol please contact the factory as above specification can change

Single Pump (2 poles) - High Available external static pressure

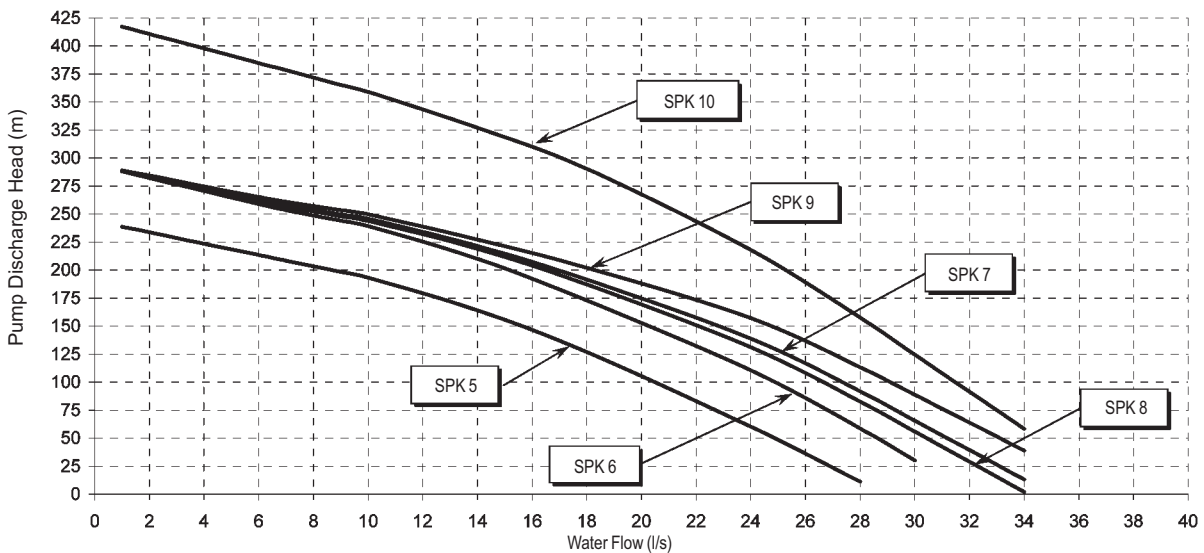

NOTES

- when using mixture of water and glycol please contact the factory as above specification can change

Pump Kit	SPK1	SPK2	SPK3	SPK4		SPK5	SPK6	SPK7		SPK8	SPK9	SPK10	
Size EWYD-BZSS	250	270	290	320	340	370	380	410	440	460	510	520	580
Size EWYD-BZSL	250	270	290	320	330	360	370	400	430	450	490	510	570

6 Options

6 - 1 Options

Water Pump Kit - Discharge Head

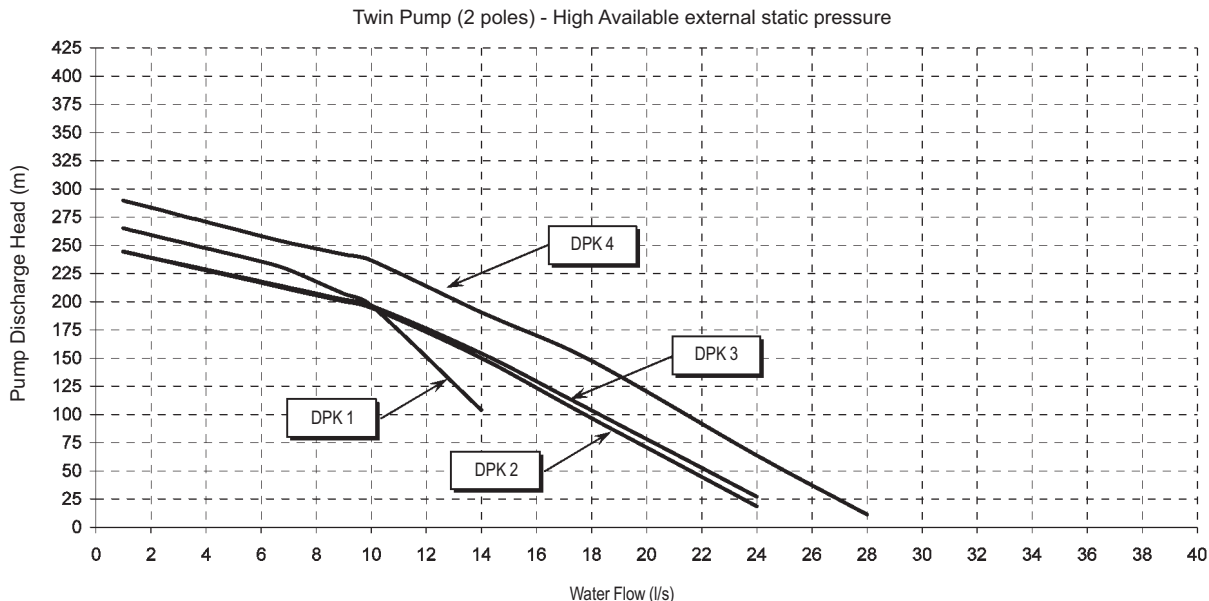

NOTES

- when using mixture of water and glycol please contact the factory as above specification can change

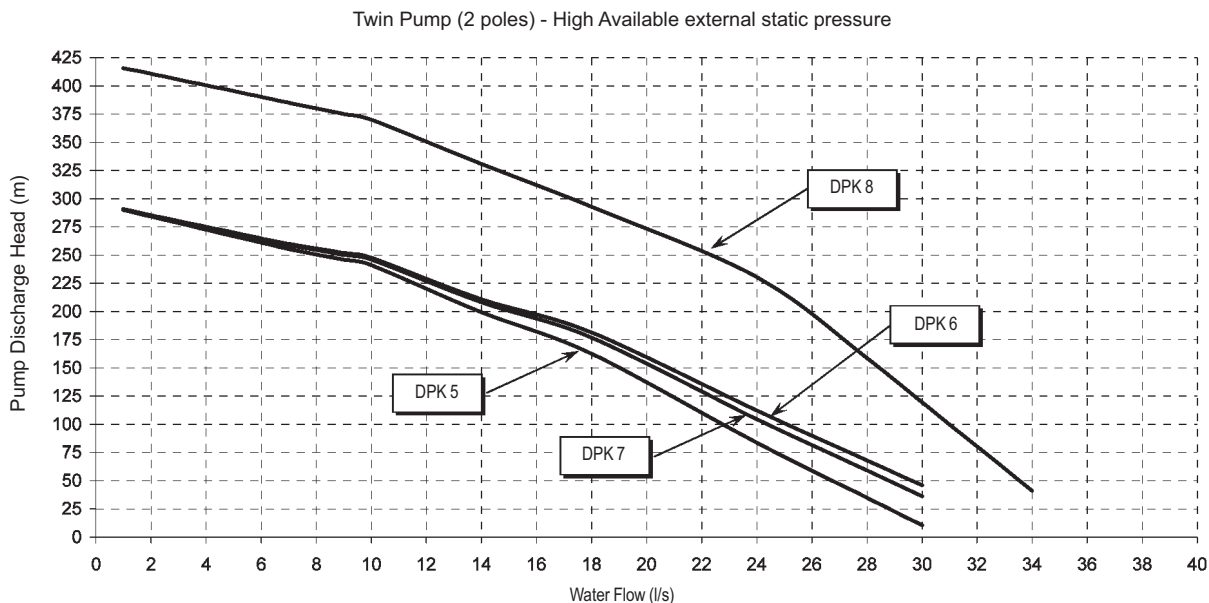

NOTES

- when using mixture of water and glycol please contact the factory as above specification can change

Pump Kit	DPK1	DPK2	DPK3	DPK4	DPK5	DPK6	DPK7	DPK8					
Size EWYD-BZSS	250	270	290	320	340	370	380	410	440	460	510	520	580
Size EWYD-BZSL	250	270	290	320	330	360	370	400	430	450	490	510	570

6 Options

6 - 1 Options

2
6

Water Pump Kit - Technical Information

		Pump Motor Power (kW)	Pump Motor Current (A)	Power supply (V-ph-Hz)	PN	Motor Protection	Insulation (Class)	Working Temp. (°C)
Single Pump Low Available Static Pressure	SPK 1	2,2	5,0	400V-3ph-50hz	10	IP55	Class F	-10 ÷ 130
	SPK 2	3,0	6,3	400V-3ph-50hz	10	IP55	Class F	-10 ÷ 130
	SPK 3	4,0	7,7	400V-3ph-50hz	10	IP55	Class F	-10 ÷ 130
	SPK 4	4,0	7,7	400V-3ph-50hz	10	IP55	Class F	-10 ÷ 130
	SPK 5	4,0	7,7	400V-3ph-50hz	10	IP55	Class F	-10 ÷ 130
	SPK 6	4,0	7,7	400V-3ph-50hz	10	IP55	Class F	-10 ÷ 130
	SPK 7	5,5	10,4	400V-3ph-50hz	10	IP55	Class F	-10 ÷ 130
	SPK 8	5,5	10,4	400V-3ph-50hz	10	IP55	Class F	-10 ÷ 130
	SPK 9	5,5	10,4	400V-3ph-50hz	10	IP55	Class F	-10 ÷ 130
	SPK 10	7,5	13,9	400V-3ph-50hz	10	IP55	Class F	-10 ÷ 130
Double Pump Low Available Static Pressure	DPK 1	3,0	6,3	400V-3ph-50hz	10	IP55	Class F	-10 ÷ 130
	DPK 2	4,0	7,7	400V-3ph-50hz	10	IP55	Class F	-10 ÷ 130
	DPK 3	4,0	7,7	400V-3ph-50hz	10	IP55	Class F	-10 ÷ 130
	DPK 4	4,0	7,7	400V-3ph-50hz	10	IP55	Class F	-10 ÷ 130
	DPK 5	5,5	10,4	400V-3ph-50hz	10	IP55	Class F	-10 ÷ 130
	DPK 6	5,5	10,4	400V-3ph-50hz	10	IP55	Class F	-10 ÷ 130
	DPK 7	5,5	10,4	400V-3ph-50hz	10	IP55	Class F	-10 ÷ 130
	DPK 8	5,5	10,4	400V-3ph-50hz	10	IP55	Class F	-10 ÷ 130
	DPK 9	7,5	13,9	400V-3ph-50hz	10	IP55	Class F	-10 ÷ 130

NOTES

- when using mixture of water and glycol please contact the factory as above specification can change

		Pump Motor Power (kW)	Pump Motor Current (A)	Power supply (V-ph-Hz)	PN	Motor Protection	Insulation (Class)	Working Temp. (°C)
Single Pump High Available Static Pressure	SPK 1	3,0	6,3	400V-3ph-50hz	10	IP55	Class F	-10 ÷ 130
	SPK 2	4,0	7,7	400V-3ph-50hz	10	IP55	Class F	-10 ÷ 130
	SPK 3	5,5	10,4	400V-3ph-50hz	10	IP55	Class F	-10 ÷ 130
	SPK 4	5,5	10,4	400V-3ph-50hz	10	IP55	Class F	-10 ÷ 130
	SPK 5	5,5	10,4	400V-3ph-50hz	10	IP55	Class F	-10 ÷ 130
	SPK 6	7,5	13,9	400V-3ph-50hz	10	IP55	Class F	-10 ÷ 130
	SPK 7	7,5	13,9	400V-3ph-50hz	10	IP55	Class F	-10 ÷ 130
	SPK 8	7,5	13,9	400V-3ph-50hz	10	IP55	Class F	-10 ÷ 130
	SPK 9	7,5	13,9	400V-3ph-50hz	10	IP55	Class F	-10 ÷ 130
	SPK 10	11,0	20,2	400V-3ph-50hz	10	IP55	Class F	-10 ÷ 130
Double Pump High Available Static Pressure	DPK 1	4,0	7,7	400V-3ph-50hz	10	IP55	Class F	-10 ÷ 130
	DPK 2	5,5	10,4	400V-3ph-50hz	10	IP55	Class F	-10 ÷ 130
	DPK 3	5,5	10,4	400V-3ph-50hz	10	IP55	Class F	-10 ÷ 130
	DPK 4	7,5	13,9	400V-3ph-50hz	10	IP55	Class F	-10 ÷ 130
	DPK 5	7,5	13,9	400V-3ph-50hz	10	IP55	Class F	-10 ÷ 130
	DPK 6	7,5	13,9	400V-3ph-50hz	10	IP55	Class F	-10 ÷ 130
	DPK 7	7,5	13,9	400V-3ph-50hz	10	IP55	Class F	-10 ÷ 130
	DPK 8	11,0	20,2	400V-3ph-50hz	10	IP55	Class F	-10 ÷ 130
	DPK 9	11,0	20,2	400V-3ph-50hz	10	IP55	Class F	-10 ÷ 130

NOTES

- when using mixture of water and glycol please contact the factory as above specification can change

7 Capacity tables

7 - 1 Cooling Capacity Tables

EWYD450-570BZSL

Ta: Condenser Inlet Air Temperature; CC: Cooling capacity; PI: Power input

Size	ELWT (°C)	Ta (°C)																				
		25				30				35				40				45				
		Rated		Boosted		Rated		Boosted		Rated		Boosted		Rated		Boosted		Rated		Boosted		
		CC	PI	CC	PI	CC	PI	CC	PI	CC	PI	CC	PI	CC	PI	CC	PI	CC	PI	CC	PI	
		kW	kW	kW	kW	kW	kW	kW	kW	kW	kW	kW	kW	kW	kW	kW	kW	kW	kW	kW	kW	kW
450	5	459.61	127.95	581.76	195.73	440.37	139.69	532.19	195.25	419.71	152.4	482.61	193.71	413.19	176.8	413.19	176.8	368.26	177.27	368.26	177.27	
	7	487.44	131.37	604.62	194.08	467.57	143.24	553.29	193.29	446.39	156.09	507.07	195.02	434.74	177.31	434.74	177.31	388.72	177.44	388.72	177.44	
	9	516.09	134.92	632.71	195.98	495.53	146.94	579.54	194.76	473.68	159.93	531.73	196.29	456.17	177.74	456.17	177.74	408.71	177.47	408.71	177.47	
	11	545.52	138.61	655.28	194.26	524.27	150.77	606.02	196.25	501.7	163.92	550.79	193.52	477.71	178.13	477.71	178.13	428.72	177.45	428.72	177.45	
	13	575.73	142.44	683.61	196.14	553.77	154.75	626.58	193.91	530.45	168.06	575.5	194.57	499.32	178.52	499.32	178.52	448.54	177.35	448.54	177.35	
	15	606.72	146.42	705.75	194.31	583.99	158.88	653.16	195.35	559.92	172.35	600.36	195.61	520.99	178.89	520.99	178.89	468.35	177.23	468.35	177.23	
490	5	505.45	142.69	659.58	239.58	483.86	155.75	605.33	238.82	460.38	169.84	555.8	241.5	484.29	224.35	484.29	224.35	430.94	222.04	430.94	222.04	
	7	535.95	146.66	689.23	241.52	513.71	159.89	635.02	241.47	490.07	174.2	578.82	239.23	506.36	222.49	506.36	222.49	454.9	222.88	454.9	222.88	
	9	567.1	150.77	717.34	241.09	544.29	164.18	659.42	239.55	519.9	178.67	606.85	241.31	531.75	223.69	531.75	223.69	478.87	223.64	478.87	223.64	
	11	599.06	155.04	743.3	239.28	575.49	168.62	689.32	241.96	550.42	183.3	631.29	239.91	555.01	223.52	555.01	223.52	502.68	224.26	502.68	224.26	
	13	631.84	159.47	775.1	241.92	607.46	173.23	713.29	239.44	581.6	188.09	657.38	240.45	576.19	221.14	576.19	221.14	526.53	224.81	526.53	224.81	
	15	665.42	164.07	800.64	239.99	640.23	178.01	743.3	241.55	613.52	193.06	681.42	238.6	601.32	222.04	601.32	222.04	545.89	221.72	545.89	221.72	
510	5	522.91	149.59	692.91	262.21	500.72	163.37	638.88	263.04	476.6	178.25	586.17	264.66	515.86	247.86	515.86	247.86	459.44	244.35	459.44	244.35	
	7	554.05	153.74	725.82	265.92	531.2	167.7	668.42	264.63	506.83	182.79	610.74	262.43	537.52	244.7	537.52	244.7	484.87	245.49	484.87	245.49	
	9	586.02	158.06	753.67	264.25	562.42	172.19	694.4	262.83	537.31	187.46	640.29	264.92	564.25	246.18	564.25	246.18	510.27	246.52	510.27	246.52	
	11	618.81	162.54	781.21	262.37	594.43	176.86	725.77	265.65	568.49	192.32	664.33	262.22	591.1	247.59	591.1	247.59	535.39	247.38	535.39	247.38	
	13	652.41	167.2	814.46	265.34	627.22	181.7	751.39	263.01	600.47	197.36	693.98	264.46	611.81	243.79	611.81	243.79	560.59	248.16	560.59	248.16	
	15	686.82	172.03	841.62	263.33	660.81	186.72	782.92	265.43	633.2	202.59	719.56	262.91	638.57	244.94	638.57	244.94	579.3	243.48	579.3	243.48	
570	5	584.8	174.75	711.81	258.46	559.11	190.92	649.94	255.74	531.49	208.46	593.85	257.29	513.95	237.38	513.95	237.38	457.07	236.99	457.07	236.99	
	7	619.33	179.82	739.13	256.53	592.82	196.2	681.34	258.27	564.51	213.97	623.41	259.26	540.72	238.34	540.72	238.34	482.28	237.4	482.28	237.4	
	9	654.75	185.09	772.65	259.26	627.36	201.7	706.41	255.47	598.19	219.66	646.65	255.74	567.02	239.12	567.02	239.12	507.15	237.66	507.15	237.66	
	11	691.04	190.57	799.47	256.76	662.74	207.42	737.9	257.64	632.63	225.59	676.19	257.43	593.36	239.82	593.36	239.82	531.9	237.81	531.9	237.81	
	13	728.19	196.27	833.11	259.43	698.95	213.35	769.57	259.75	667.89	231.78	705.84	259.04	619.76	240.44	619.76	240.44	556.31	237.82	556.31	237.82	
	15	766.19	202.18	859.22	256.71	735.96	219.51	793.67	256.3	703.9	238.2	727.88	254.85	646.17	241.01	646.17	241.01	580.51	237.71	580.51	237.71	

NOTES - ANMERKUNGEN - Σημειώσεις - NOTAS - REMARQUES - NOTE - OPMERKINGEN - ПРИМЕЧАНИЯ

- 1 ELWT = Evaporator Leaving Water Temperature
 ELWT = Verdampfer-Austrittswassertemperatur
 ELWT = Θερμοκρασία νερού εξόδου εξατμιστή
 ELWT = Temperatura del agua de salida del evaporador
 ELWT = Température de l'eau en sortie de l'évaporateur
 ELWT = Temperatura acqua in uscita evaporatore
 ELWT = Temperatuur van uitlaatwater van verdampfer
 ELWT = Температура воды на выходе испарителя
- 2 Rated / Boosted
 Nominal / Verstärkt
 Ονομαστική / Ενισχυμένη
 Nominal / Aumentado
 Nominale / Accrue
 Nominale / Potenziata
 Nominaal / In boost-modus
 Номинал / С бустером

8 Pressure drops

8 - 1 Evaporator Pressure Drops

Evaporating Pressure Drops

EWYD~BZSS	250	270	290	320	340	370	380	410	440	460	510	520	580
Cooling Capacity (kW)	254	273	292	324	339	365	382	413	436	457	505	522	583
Water Flow (l/s)	12,12	13,03	13,94	15,46	16,21	17,42	18,25	19,72	20,81	21,83	24,11	24,92	27,87
Pressure Drops (kPa)	37	42	48	53	58	53	57	46	51	61	50	53	65

Water flow and pressure drop referred to nominal condition: evaporator water in/out: 12/7°C – condenser air inlet: 35°C

EWYD~BZSS	250	270	290	320	340	370	380	410	440	460	510	520	580
Heating Capacity (kW)	270	297	324	333	349	379	410	443	463	475	530	558	615
Water Flow (l/s)	12,89	14,18	15,49	15,89	16,66	18,11	19,57	21,15	22,14	22,68	25,33	26,65	29,39
Pressure Drops (kPa)	42	49	58	55	60	57	65	52	57	66	55	60	71

Water flow and pressure drop referred to nominal condition: evaporator water in/out: 12/7°C – condenser air inlet: 35°C

EWYD~BZSL	250	270	290	320	330	360	370	400	430	450	490	510	570
Cooling Capacity (kW)	248	266	291	316	331	355	372	403	425	448	493	510	567
Water Flow (l/s)	11,83	12,70	13,89	15,12	15,83	16,98	17,77	19,28	20,30	21,39	23,56	24,34	27,11
Pressure Drops (kPa)	36	40	48	51	55	50	55	44	48	59	48	51	62

Water flow and pressure drop referred to nominal condition: evaporator water in/out: 12/7°C – condenser air inlet: 35°C

EWYD~BZSL	250	270	290	320	330	360	370	400	430	450	490	510	570
Heating Capacity (kW)	270	297	324	333	349	379	410	443	463	475	530	558	615
Water Flow (l/s)	12,89	14,18	15,49	15,89	16,66	18,11	19,57	21,15	22,14	22,68	25,33	26,65	29,39
Pressure Drops (kPa)	42	49	58	55	60	57	65	52	57	66	55	60	71

Water flow and pressure drop referred to nominal condition: evaporator water in/out: 12/7°C – condenser air inlet: 35°C

Evaporating Pressure Drops

To determine the pressure drop for different versions or at different working conditions, please refer to the following formula:

$$PD_2 \text{ (kPa)} = PD_1 \text{ (kPa)} \times \left(\frac{Q_2 \text{ (l/s)}}{Q_1 \text{ (l/s)}} \right)^{1.8}$$

where:

- PD₂ Pressure drop to be determinate (kPa)
- PD₁ Pressure drop at nominal condition (kPa)
- Q₂ water flow at new working condition (l/s)
- Q₁ water flow at nominal condition (l/s)

How to use the formula: Example

The unit EWAD650C-SS has been selected for working at the following conditions:

- evaporator water in/out : 11/6°C
- condenser air inlet: 30°C

The cooling capacity at these working conditions is: 265 kW (Rated conditions)

The water flow at these working conditions is: 12.68 l/s (Rated conditions)

The unit EWYD250BZSS at nominal working conditions has the following data:

- evaporator water in/out : 12/7°C
- condenser air inlet: 35°C

The cooling capacity at these working conditions is: 254 kW

The water flow at these working conditions is: 12.12 l/s

The pressure drop at these working conditions is: 37 kPa

The pressure drop at the selected working condition will be:

$$PD_2 \text{ (kPa)} = 37 \text{ (kPa)} \times \left(\frac{12.68 \text{ (l/s)}}{12.12 \text{ (l/s)}} \right)^{1.8}$$

$$PD_2 \text{ (kPa)} = 52 \text{ (kPa)}$$

NOTES

If the calculated evaporator water pressure drop is below 10 kPa or above 100 kPa please contact the factory for dedicated evaporator.

9 Centre of gravity

9 - 1 Centre of Gravity

Dimensions EWYD-BZ

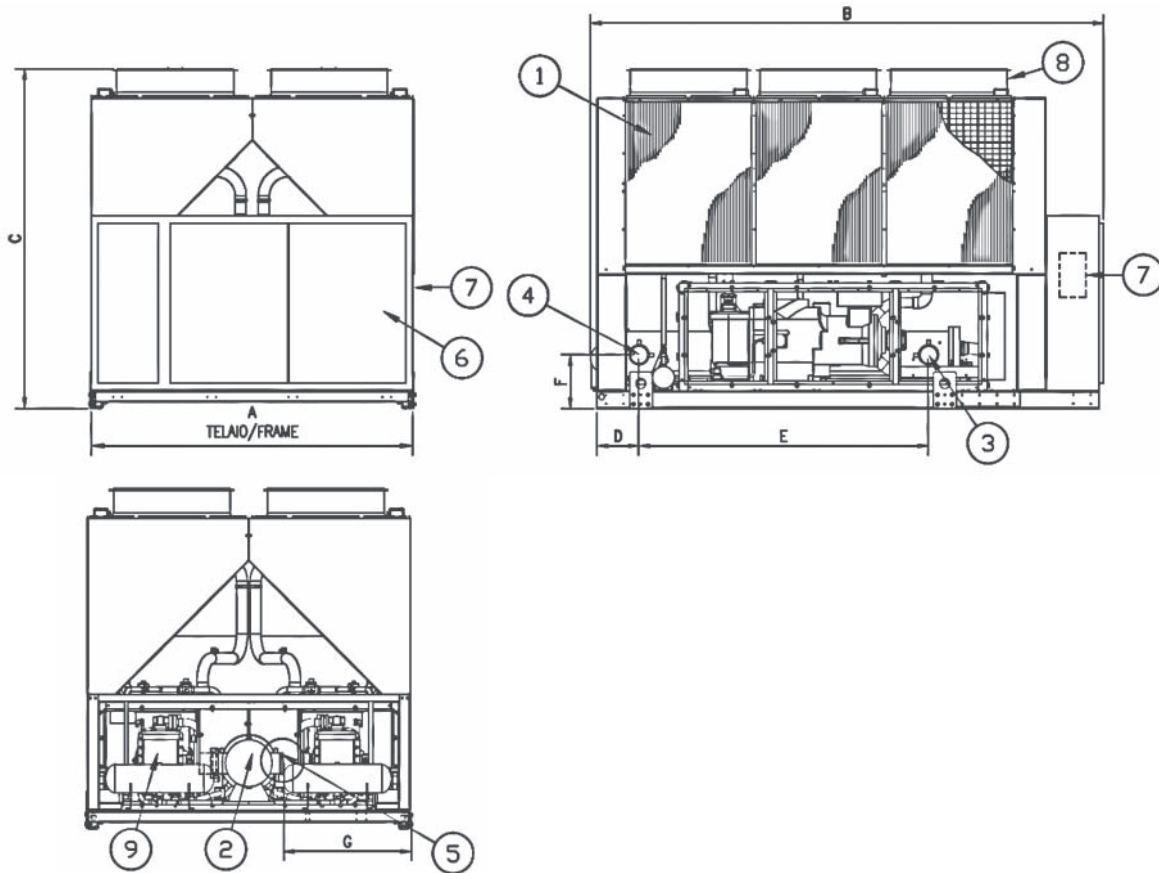

Size		Dimensions							
BZSS	BZSL	A	B	C	D	E	F	G	Fans
250	250	2254	3547	2335	288	2000	449	852	6
270	270	2254	3547	2335	288	2000	449	852	6
290	290	2254	3547	2335	288	2000	449	852	8
320	320	2254	4381	2335	290	2000	449	852	8
340	330	2254	4381	2335	290	2000	449	852	8
370	360	2254	4381	2335	290	2000	449	852	8
380	370	2254	4381	2335	290	2000	449	852	8
410	400	2254	5281	2335	290	2000	449	852	10
440	430	2254	5281	2335	290	2000	449	852	10
460	450	2254	6583	2335	290	2000	449	852	12
510	490	2254	6583	2335	451	1973	503	809	12
520	510	2254	6583	2335	451	1973	503	809	12
580	570	2254	6583	2335	451	1973	503	809	12

NOTES

- 1 Air heat exchanger (condenser – evaporator)
- 2 Water heat exchanger (evaporator – condenser)
- 3 Evaporator water inlet
- 4 Evaporator water outlet
- 5 Victaulic connection
- 6 Electrical control panel
- 7 Slot for power and control connection
- 8 Fan
- 9 Compressor

DMN_1_Rev.00

10 Sound data

10 - 1 Sound Level Data

Sound Levels

EWYD-BZ - Cooling

EWYD-BZSS

Unit size		Sound pressure level at 1 m from the unit in semispheric free field (rif. 2 x 10 ⁻⁵ Pa)								Power	
		63 Hz	125 Hz	250 Hz	500 Hz	1000 Hz	2000 Hz	4000 Hz	8000 Hz	dB(A)	dB(A)
250÷290	Rated	77.0	75.6	75.8	74.9	81.1	69.3	60.7	51.9	82.1	100.5
	Min	77.0	75.1	73.8	74.0	72.2	66.2	58.9	49.5	75.9	94.4
	Boost	77.4	78.6	79.1	80.7	79.5	74.7	66.5	58.0	83.1	101.5
320÷380	Rated	77.2	75.8	76.0	75.1	81.3	69.5	60.9	52.1	82.3	101.2
	Min	77.2	75.3	74.0	74.2	72.4	66.4	59.1	49.7	76.1	95.0
	Boost	78.5	79.7	80.2	81.8	80.6	75.8	67.6	59.1	84.2	103.1
410÷440	Rated	77.4	76.0	76.2	75.3	81.5	69.7	61.1	52.3	82.5	101.8
	Min	77.4	75.5	74.2	74.4	72.6	66.6	59.3	49.9	76.3	95.7
	Boost	78.7	79.9	80.4	82.0	80.8	76.0	67.8	59.3	84.4	103.7
460÷580	Rated	78.6	77.2	77.4	76.5	82.7	70.9	62.3	53.5	83.7	103.6
	Min	78.6	76.7	75.4	75.6	73.8	67.8	60.5	51.1	77.5	97.4
	Boost	79.9	81.1	81.6	83.2	82.0	77.2	69.0	60.5	85.6	105.4

EWYD-BZSL

Unit size		Sound pressure level at 1 m from the unit in semispheric free field (rif. 2 x 10 ⁻⁵ Pa)								Power	
		63 Hz	125 Hz	250 Hz	500 Hz	1000 Hz	2000 Hz	4000 Hz	8000 Hz	dB(A)	dB(A)
250÷290	Rated	76.1	72.4	70.9	69.6	74.2	63.9	55.5	46.3	75.6	94.0
	Min	76.1	72.5	70.5	69.8	68.6	62.8	55.1	45.7	72.3	90.7
	Boost	76.2	73.6	72.8	73.7	72.6	67.7	59.5	50.8	76.2	94.6
320÷370	Rated	76.3	72.6	71.1	69.8	74.4	64.1	55.7	46.5	75.8	94.7
	Min	76.3	72.7	70.7	70.0	68.8	63.0	55.3	45.9	72.5	91.4
	Boost	76.4	73.8	73.0	73.9	72.8	67.9	59.7	51.0	76.4	95.3
400÷430	Rated	76.5	72.8	71.3	70.0	74.6	64.3	55.9	46.7	76.0	95.3
	Min	76.5	72.9	70.9	70.2	69.0	63.2	55.5	46.1	72.7	92.0
	Boost	76.6	74.0	73.2	74.1	73.0	68.1	59.9	51.2	76.6	95.9
450÷570	Rated	77.7	74.0	72.5	71.2	75.8	65.5	57.1	47.9	77.2	97.0
	Min	77.7	74.1	72.1	71.4	70.2	64.4	56.7	47.3	73.9	93.7
	Boost	77.8	75.2	74.4	75.3	74.2	69.3	61.1	52.4	77.8	97.6

NOTES

- Rated (nominal frequency)
- Min (minimum frequency)
- Boost (maximum frequency)

10 Sound data

10 - 1 Sound Level Data

Sound Levels

EWYD~BZ - Heating

EWYD-BZSS

Unit size		Sound pressure level at 1 m from the unit in semispheric free field (rif. 2 x 10 ⁻⁵ Pa)									Power	
		63 Hz	125 Hz	250 Hz	500 Hz	1000 Hz	2000 Hz	4000 Hz	8000 Hz	dB(A)	dB(A)	
250+290	Rated	77,0	75,6	75,8	74,9	81,1	69,3	60,7	51,9	82,1	100,5	
	Min	77,0	75,1	73,8	74,0	72,2	66,2	58,9	49,5	75,9	94,4	
	Boost	77,4	78,6	79,1	80,7	79,5	74,7	66,5	58,0	83,1	101,5	
320+380	Rated	77,2	75,8	76,0	75,1	81,3	69,5	60,9	52,1	82,3	101,2	
	Min	77,2	75,3	74,0	74,2	72,4	66,4	59,1	49,7	76,1	95,0	
	Boost	78,5	79,7	80,2	81,8	80,6	75,8	67,6	59,1	84,2	103,1	
410+440	Rated	77,4	76,0	76,2	75,3	81,5	69,7	61,1	52,3	82,5	101,8	
	Min	77,4	75,5	74,2	74,4	72,6	66,6	59,3	49,9	76,3	95,7	
	Boost	78,7	79,9	80,4	82,0	80,8	76,0	67,8	59,3	84,4	103,7	
460+580	Rated	78,6	77,2	77,4	76,5	82,7	70,9	62,3	53,5	83,7	103,6	
	Min	78,6	76,7	75,4	75,6	73,8	67,8	60,5	51,1	77,5	97,4	
	Boost	79,9	81,1	81,6	83,2	82,0	77,2	69,0	60,5	85,6	105,4	

EWYD-BZSL

Unit size		Sound pressure level at 1 m from the unit in semispheric free field (rif. 2 x 10 ⁻⁵ Pa)									Power	
		63 Hz	125 Hz	250 Hz	500 Hz	1000 Hz	2000 Hz	4000 Hz	8000 Hz	dB(A)	dB(A)	
250+290	Rated	78,1	74,1	72,3	70,8	74,8	65,1	56,8	47,5	76,5	94,9	
	Min	78,1	74,1	71,8	70,9	69,9	64,2	56,4	46,9	73,5	91,9	
	Boost	78,1	74,9	73,7	74,1	73,2	68,2	60,0	51,2	76,7	95,1	
320+370	Rated	79,5	75,5	74,1	71,5	75,1	67,6	59,6	51,0	77,2	96,1	
	Min	78,3	74,3	72,0	71,1	70,1	64,4	56,6	47,1	73,7	92,6	
	Boost	78,3	75,1	73,9	74,3	73,4	68,4	60,2	51,4	76,9	95,8	
400+430	Rated	79,7	75,7	74,3	71,7	75,3	67,8	59,8	51,2	77,4	96,7	
	Min	78,5	74,5	72,2	71,3	70,3	64,6	56,8	47,3	73,9	93,2	
	Boost	78,5	75,3	74,1	74,5	73,6	68,6	60,4	51,6	77,1	96,4	
450+570	Rated	80,9	76,9	75,5	72,9	76,5	69,0	61,0	52,4	78,6	98,4	
	Min	79,7	75,7	73,4	72,5	71,5	65,8	58,0	48,5	75,1	94,9	
	Boost	79,7	76,5	75,3	75,7	74,8	69,8	61,6	52,8	78,3	98,1	

NOTES

- Rated (nominal frequency)
- Min (minimum frequency)
- Boost (maximum frequency)

10 Sound data

10 - 1 Sound Level Data

Sound pressure level correction factors for different distances

EWYD~BZ

EWYD~BZSS / EWYD~BZSL

Unit size		Distance						
BZSS	BZSL	1m	5m	10m	15m	20m	25m	50m
250	250	0,0	6,2	10,3	13,0	15,1	16,8	22,2
270	270	0,0	6,2	10,3	13,0	15,1	16,8	22,2
290	290	0,0	6,2	10,3	13,0	15,1	16,8	22,2
320	320	0,0	5,9	9,9	12,6	14,7	16,4	21,8
340	330	0,0	5,9	9,9	12,6	14,7	16,4	21,8
370	360	0,0	5,9	9,9	12,6	14,7	16,4	21,8
380	370	0,0	5,9	9,9	12,6	14,7	16,4	21,8
410	400	0,0	5,7	9,6	12,3	14,3	16,0	21,4
440	130	0,0	5,7	9,6	12,3	14,3	16,0	21,4
460	450	0,0	5,4	9,3	11,9	13,9	15,6	20,9
510	490	0,0	5,4	9,3	11,9	13,9	15,6	20,9
520	510	0,0	5,4	9,3	11,9	13,9	15,6	20,9
580	570	0,0	5,4	9,3	11,9	13,9	15,6	20,9

11 Installation

11 - 1 Installation Method

Installation notes

Warning

Installation and maintenance of the unit must to be performed only by qualified personnel who have knowledge with local codes and regulations, and experience with this type of equipment. Must be avoided the unit installation in places that could be considered dangerous for all the maintenance operations.

Handling

Care should be taken to avoid rough handling or shock due to dropping the unit. Do not push or pull the unit from anything other than the base frame. Never allow the unit to fall during unloading or moving as this may result in serious damage. To lift the unit, rings are provided in the base frame of the unit. Spreader bar and cables should be arranged to prevent damage to the condenser coil or unit cabinet.

Location

The units are produced for outside installation on roofs, floors or below ground level on condition that the area is free from obstacles for the passage of the condenser air. The unit should be positioned on solid foundations and perfectly level; in the case of installation on roofs or floors, it may be advisable to arrange the use of suitable weight distribution beams. When the units are installed on the ground, a concrete base at least 250 mm wider and longer than the unit's footprint should be laid. Furthermore, this base should withstand the unit weight mentioned in the technical data table.

Space requirements

The units are air-cooled, then it is important to respect the minimum distances which guarantee the best ventilation of the condenser coils. Limitations of space reducing the air flow could cause significant reductions in cooling capacity and an increase in electricity consumption.

To determinate unit placement, careful consideration must be given to assure a sufficient air flow across the condenser heat transfer surface. Two conditions must be avoided to achieve the best performance: warm air recirculation and coil starvation. Both these conditions cause an increase of condensing pressures that result in reductions in unit efficiency and capacity.

Moreover the unique microprocessor has the ability to calculate the operating environment of the air cooled chiller and the capacity to optimize its performance staying on-line during abnormal conditions.

Each side of the unit must be accessible after installation for periodic service. Fig.1 shows you minimum recommended clearance requirements.

Vertical condenser air discharge must be unobstructed because the unit would have its capacity and efficiency significantly reduced.

If the units are positioned in places surrounded by walls or obstacles of the same height as the units, the units should be at least 2500 mm from obstacles (fig.2). In the event the obstacles are higher than the units, the units should be at least 3000 mm from the obstacle (fig.4). Units installed closer than the minimum recommended distance to a wall or other vertical riser may experience a combination of coil starvation and warm air recirculation, thus causing reduction in unit capacity and efficiency reductions. The microprocessor control is proactive in response "of design condition". In the case of single or compounded influences restricting airflow to the unit, the microprocessor will act to keep the compressor(s) running (at reduced capacity) rather than allowing a shut-off on high discharge pressure.

When two or more units are positioned side by side it is recommended that the condenser coils are at least 3600 mm distance from one another (fig.3); strong wind could be the cause of air warm recirculation.

For other installation solutions, consult our technicians.

11 Installation

11 - 1 Installation Method

The above recommended information are representative of general installation. A specific evaluation should be done by contractor depending on the case.

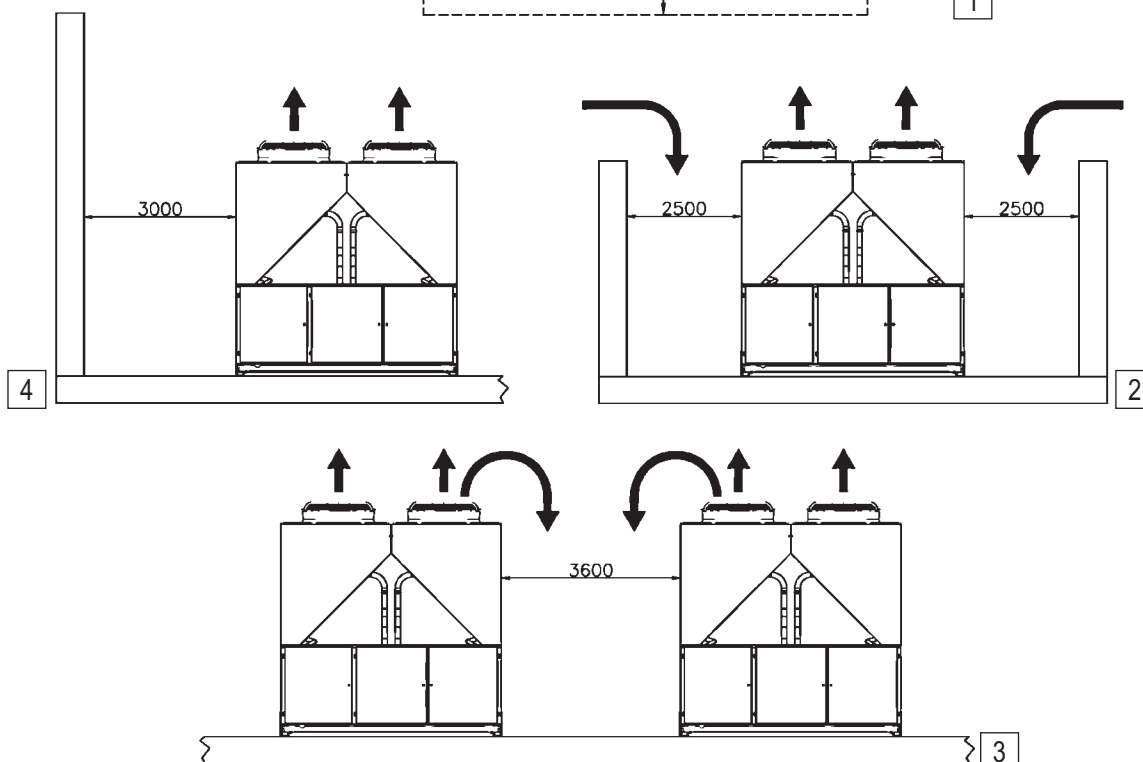
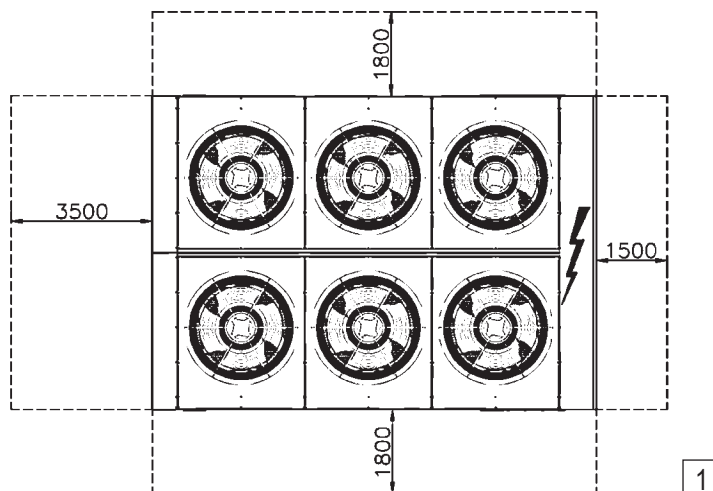

Acoustic protection

When noise level must meet special requirements, it is necessary to pay the maximum attention to ensure the perfect insulation of the unit from the support base by applying appropriate vibration-dampening devices on the unit, on the water pipes and on the electrical connections.

Storage

The environment conditions have to be in the following limits:

Minimum ambient temperature:	-20°C
Maximum ambient temperature:	+57°C
Maximum R.H.:	95% not condensing

12 Operation range

12 - 1 Operation Range

2
12

Cooling Mode

EWYD~BZSS and EWYD~BZSL

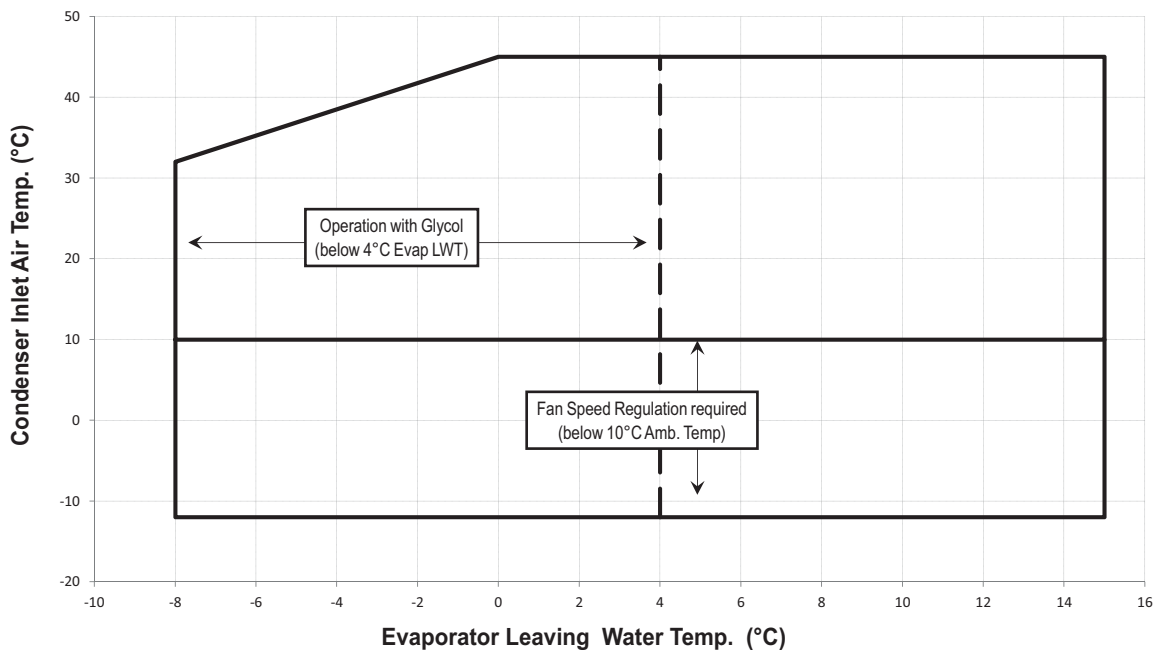

Heating Mode

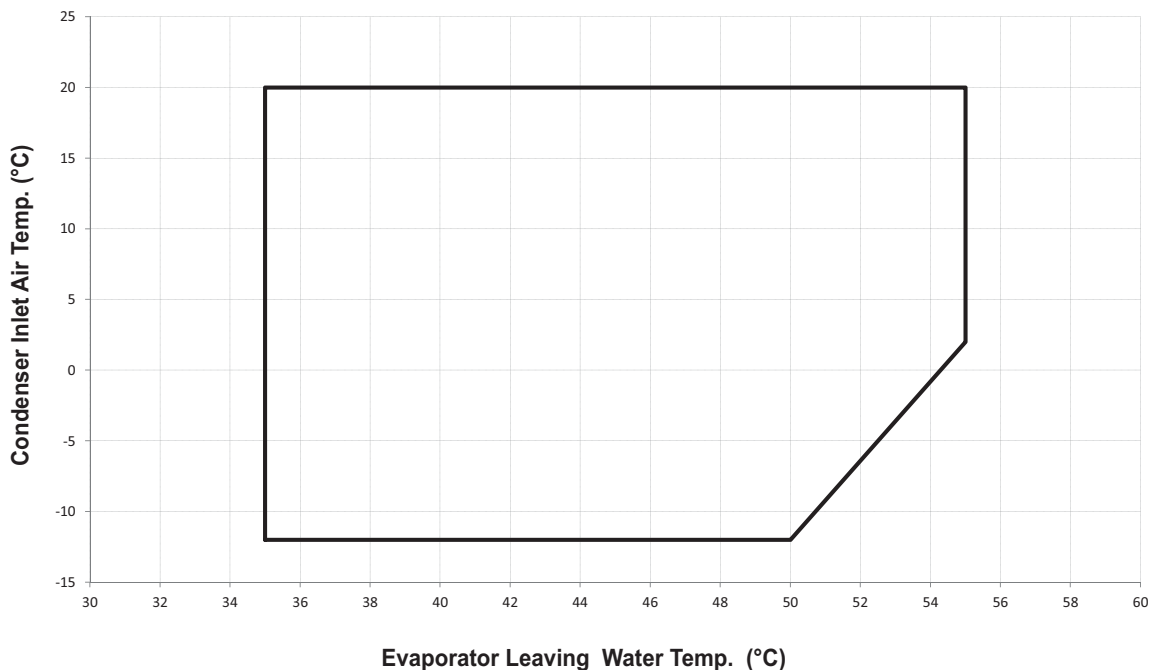

12 Operation range

12 - 1 Operation Range

2
12

Table 1 - Water heat exchanger - Minimum and maximum water Δt

Max evaporator water Δt	°C	8
Min evaporator water Δt	°C	4

Note: Table referred to Cooling and Heating Mode

Table 2 - Water heat exchanger - Fouling factors

Fouling factors m ² °C / kW	Cooling capacity correction factor	Power input correction factor	EER correction factor
0,0176	1,000	1,000	1,000
0,0440	0,978	0,986	0,992
0,0880	0,957	0,974	0,983
0,1320	0,938	0,962	0,975

Note: Table referred to Cooling and Heating Mode

Table 3 - Air heat exchanger - Altitude correction factors

Elevation above sea level (m)	0	300	600	900	1200	1500	1800
Barometric pressure (mbar)	1013	977	942	908	875	843	812
Cooling capacity correction factor	1,000	0,993	0,986	0,979	0,973	0,967	0,960
Power input correction factor	1,000	1,005	1,009	1,015	1,021	1,026	1,031

Note: Table referred to Cooling Mode only

Note: Maximum operating altitude is 2000 m above sea level

Note: Contact factory in case the unit has to be installed at altitudes between 1000 and 2000 m above sea level

Table 4.1 - Minimum glycol percentage for low water temperature

Evaporator Leaving Water Temperature (°C)	2	0	-2	-4	-6	-8
Ethylene glycol (%)	10	20	20	20	30	30
Propylene glycol (%)	10	20	20	30	30	30

Note: Table referred to Cooling Mode only

Note: Minimum glycol percentage to be used with evaporator leaving water temperature below 4°C to prevent freezing of water circuit.

Table 4.2 - Minimum glycol percentage for low air ambient temperature

Air Ambient Temperature (°C) (2)	-3	-8	-15	-20
Ethylene glycol (%) (1)	10%	20%	30%	40%
Air Ambient Temperature (°C) (2)	-3	-7	-12	-20
Propylene glycol (%) (1)	10%	20%	30%	40%

Minimum glycol percentage to prevent freezing of water circuit at indicated air ambient temperature

Air ambient temperature do exceed the operating limits of the unit, as protection of water circuit may be needed in winter season at non-working conditions.

Table 5 - Correction factors for low evaporator leaving water temperature

Evaporator Leaving Water Temperature (°C)	2	0	-2	-4	-6	-8
Cooling Capacity	0,842	0,785	0,725	0,670	0,613	0,562
Compressor Power Input	0,950	0,940	0,920	0,890	0,870	0,840

Note: Table referred to Cooling Mode only

Note: Correction factors have to be applied at working conditions: evaporator leaving water temperature 7°C

Table 6 - Correction factors for water and glycol mixture

	Ethylene Glycol (%)	10%	20%	30%	40%	50%
Ethylene Glycol	Cooling Capacity	0,991	0,982	0,972	0,961	0,946
	Compressor Power Input	0,996	0,992	0,986	0,976	0,966
	Flow Rate (Δt)	1,013	1,04	1,074	1,121	1,178
	Evaporator Pressure Drop	1,070	1,129	1,181	1,263	1,308
Propylene Glycol	Cooling Capacity	0,985	0,964	0,932	0,889	0,846
	Compressor Power Input	0,993	0,983	0,969	0,948	0,929
	Flow Rate (Δt)	1,017	1,032	1,056	1,092	1,139
	Evaporator Pressure Drop	1,120	1,272	1,496	1,792	2,128

Note: Table referred to Cooling Mode only

Note: In Heating mode correction factor is 1 at water temperature between operating limits

Note: Contact factory for water temperature out of operating limits

12 Operation range

12 - 1 Operation Range

How to use the Correction factors proposed in the previous tables

A) Mixture Water and Glycol --- Evaporator leaving water temperature > 4°C

- depending from the type and percentage (%) of glycol filled in the circuit (see table 4.2 and 6)
- multiply the Cooling Capacity, the Compressor Power Input by the Correction factor of Table 6
- starting from this new value of Cooling Capacity, calculate the Flow Rate (l/s) and the Evaporator Pressure Drop (kPa)
- now multiply the new Flow Rate and the new Evaporator Pressure Drop by the Correction Factors of Table 6

Example:

Unit Size: EWYD250BZSS

- Mixture: Water
- Working condition: ELWT 12/7°C – Condenser inlet air temperature 35°C
- Cooling capacity: 254 kW (Rated conditions)
 - Power input: 90.3 kW (Rated conditions)
 - Flow rate (Δt 5°C): 12.12 l/ss
 - Evaporator pressure drop: 37 kPa

- Mixture: Water + Ethylene Glycol 30% (for a winter air temperature up to -15°C)
- Working condition: ELWT 12/7°C - Condenser inlet air temperature 35°C
- Cooling capacity: $254 \times 0.972 = 247\text{kW}$
 - Power input: $90.3 \times 0.986 = 89.0\text{ kW}$
 - Flow rate (Δt 5°C): 11.80 (referred to 247 kW) $\times 1.074 = 12.67\text{ l/s}$
 - Evaporator pressure drop: 40 (referred to 12.67 l/s) $\times 1.181 = 47\text{ kPa}$

B) Mixture Water and Glycol --- Evaporator leaving water temperature < 4°C

- depending from the type and percentage (%) of glycol filled in the circuit (see table 4.1 and 4.2 and table 6)
- depending from the evaporator leaving water temperature (see table 5)
- multiply the Cooling Capacity, the Compressor Power Input by the Correction factor of Table 5 and Table 6
- starting from this new value of Cooling Capacity, calculate the Flow Rate (l/s) and the Evaporator Pressure Drop (kPa)
- now multiply the new Flow Rate and the new Evaporator Pressure Drop by the Correction Factors of Table 6

Example:

Unit Size: EWYD250BZSS

- Mixture: Water
- Working condition: ELWT 12/7°C – Condenser inlet air temperature 30°C
- Cooling capacity: 265 kW (Rated conditions)
 - Power input: 83.3 kW (Rated conditions)
 - Flow rate (Δt 5°C): 12.66 l/s
 - Evaporator pressure drop: 40 kPa

- Mixture: Water + Glycol 30% (for a low evaporator leaving temperature of -1/-6°C)
- Working condition: ELWT -1/-6°C – Condenser inlet air temperature 30°C
- Cooling capacity: $265 \times 0.613 \times 0.972 = 158\text{ kW}$
 - Power input: $83.3 \times 0.870 \times 0.986 = 71.5\text{ kW}$
 - Flow rate (Δt 5°C): 7.54 l/s (referred to 158 kW) $\times 1.074 = 8.10\text{ l/s}$
 - Evaporator pressure drop: 18 kPa (referred to 8.10 l/s) $\times 1.181 = 21\text{ kPa}$

12 Operation range

12 - 1 Operation Range

Water charge, flow and quality

Items ⁽¹⁾⁽⁵⁾	Cooling Water			Cooled Water		Heated water ⁽²⁾				Tendency if out of criteria
	Circulating System		Once Flow	Circulating water [Below 20°C]	Supply water ⁽⁴⁾	Low temperature		High temperature		
	Circulating water	Supply water ⁽⁴⁾	Flowing water			Circulating water [20°C ~ 60°C]	Supply water ⁽⁴⁾	Circulating water [60°C ~ 80°C]	Supply water ⁽⁴⁾	
pH	at 25°C	6.5 ~ 8.2	6.0 ~ 8.0	6.0 ~ 8.0	6.0 ~ 8.0	7.0 ~ 8.0	7.0 ~ 8.0	7.0 ~ 8.0	7.0 ~ 8.0	Corrosion + Scale
Electrical conductivity	[mS/m] at 25°C	Below 80	Below 30	Below 40	Below 40	Below 30	Below 30	Below 30	Below 30	Corrosion + Scale
Chloride ion	[μS/cm] at 25°C	(Below 800)	(Below 300)	(Below 400)	(Below 400)	(Below 300)	(Below 300)	(Below 300)	(Below 300)	Corrosion + Scale
Sulfate ion	[mgSO ₂ -/l]	Below 200	Below 50	Below 50	Below 50	Below 50	Below 50	Below 50	Below 50	Corrosion
M-alkalinity (pH4.8)	[mgCaCO ₃ /l]	Below 100	Below 50	Below 50	Below 50	Below 50	Below 50	Below 50	Below 50	Scale
Total hardness	[mgCaCO ₃ /l]	Below 200	Below 70	Below 70	Below 70	Below 70	Below 70	Below 70	Below 70	Scale
Calcium hardness	[mgCaCO ₃ /l]	Below 150	Below 50	Below 50	Below 50	Below 50	Below 50	Below 50	Below 50	Scale
Silica ion	[mgSiO ₂ /l]	Below 50	Below 30	Below 30	Below 30	Below 30	Below 30	Below 30	Below 30	Scale
Oxygen	(mg O ₂ /l)	Below 1.0	Below 1.0	Below 1.0	Below 1.0	Below 1.0	Below 1.0	Below 1.0	Below 1.0	Corrosion
Particulate size	(mm)	Below 0.5	Below 0.5	Below 0.5	Below 0.5	Below 0.6	Below 0.6	Below 0.5	Below 0.6	Erosion
Total dissolved solids	(mg /l)	Below 1000	Below 1000	Below 1000	Below 1000	Below 1001	Below 1000	Below 1000	Below 1001	Erosion
Ethylene, Propylene Glycol (weight conc.)		Below 60%	Below 60%	---	Below 60%	Below 60%	Below 60%	Below 60%	Below 60%	--
Nitrate ion	(mg NO ₃ -/l)	Below 100	Below 100	Below 100	Below 100	Below 101	Below 100	Below 101	Below 101	Corrosion
TOC Total organic carbon	(mg /l)	Below 1.0	Below 1.0	Below 1.0	Below 1.0	Below 1.0	Below 1.0	Below 1.0	Below 1.0	Scale
Iron	(mgFe/l)	Below 1.0	Below 0.3	Below 1.0	Below 1.0	Below 0.3	Below 1.0	Below 0.3	Below 1.0	Corrosion + Scale
Copper	(mgCu/l)	Below 0.3	Below 0.1	Below 1.0	Below 1.0	Below 1.0	Below 1.0	Below 0.1	Below 1.0	Corrosion
Sulfite ion	[mgS ₂ -/l]	Not detectable	Not detectable	Not detectable	Not detectable	Not detectable	Not detectable	Not detectable	Not detectable	Corrosion
Ammonium ion	[mgNH ₄ /l]	Below 1.0	Below 0.1	Below 1.0	Below 1.0	Below 0.1	Below 0.3	Below 0.1	Below 0.1	Corrosion
Remaining chloride	[mgCL/l]	Below 0.3	Below 0.3	Below 0.3	Below 0.3	Below 0.3	Below 0.25	Below 0.3	Below 0.1	Corrosion
Free carbide	[mgCO ₂ /l]	Below 4.0	Below 4.0	Below 4.0	Below 4.0	Below 4.0	Below 4.0	Below 4.0	Below 4.0	Corrosion
Stability index		6.0 ~ 7.0	---	---	---	---	---	---	---	Corrosion + Scale

- Names, definitions and units are according to JIS K 0101. Units and figures between brackets are old units published as reference only.
- In case of using heated water (more than 40°C), corrosion is generally noticeable. Especially when the iron materials is in direct contact with water without any protection shields, it is desirable to give the valid measure for corrosion. E.g. chemical measure
- In the cooling water using hermetic cooling tower, close circuit water is according to heated water standard, and scattered water is according to cooling water standard.
- Supply water is considered drink water, industrial water and ground water except for genuine water, neutral water and soft water.
- The above mentioned items are representable items in corrosion and scale cases.
- The limits above have to be considered as a general prescription and can not totally assure the absence of corrosion and erosion. Some particular combinations of elements or the presence of components not listed in the table or factors not considered may trigger corrosion phenomena.

Water content in cooling circuits

The cooled water distribution circuits should have minimum water content to avoid excessive compressors start and stop. In fact, each time the compressor starts up, an excessive quantity of oil goes from the compressor sump and simultaneously there is a rise in the temperature of the compressor motor's stator due to the inrush current during the start-up. To prevent damage to the compressors, it has been envisaged the application of a device to limit frequent stops and restarts.

During the span of one hour there will be no more than 6 starts of the compressor. The plant side should therefore ensure that the overall water content allows a more constant functioning of the unit and consequently greater environmental comfort. The minimum water content per unit should be calculated using this simplified formula:

For 2 compressors unit
 $M \text{ (liters)} = (0.1595 \times \Delta T(^{\circ}C) + 3.0825) \times P \text{ (kW)}$

For 3 compressors unit
 $M \text{ (liters)} = (0.0443 \times \Delta T(^{\circ}C) + 1.6202) \times P \text{ (kW)}$

where:

- M minimum water content per unit expressed in litres
- P Cooling Capacity of the unit expressed in kW
- ΔT evaporator entering / leaving water temperature difference expressed in °C

This formula is valid for:
 - standard microprocessor parameters

For more accurate determination of quantity of water, it is advisable to contact the designer of the plant.

12 Operation range

12 - 1 Operation Range

Automatic and Manual Boost --- Cooling Mode

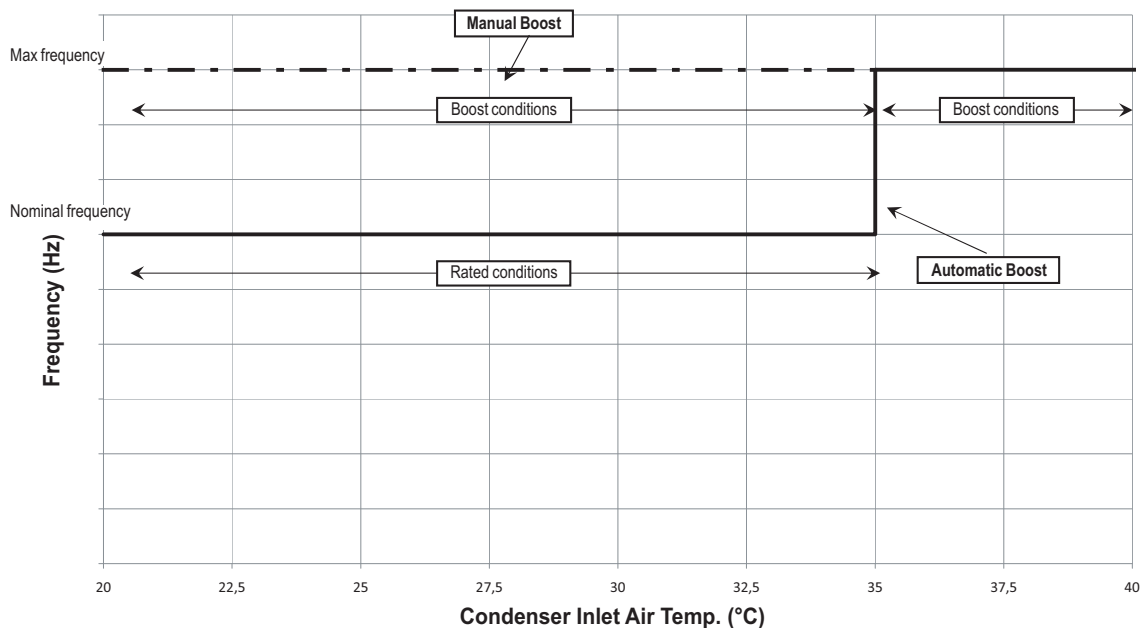

NOTES

1. Automatic boost: unit standard configuration
2. Manual boost: customized configuration by different settings
3. Rated conditions: compressors are working at nominal frequency
4. Boost conditions: compressors are working at the maximum frequency
5. Both automatic and manual boost maximum frequency depends on the maximum current suppliable by the inverter

Automatic and Manual Boost --- Heating Mode

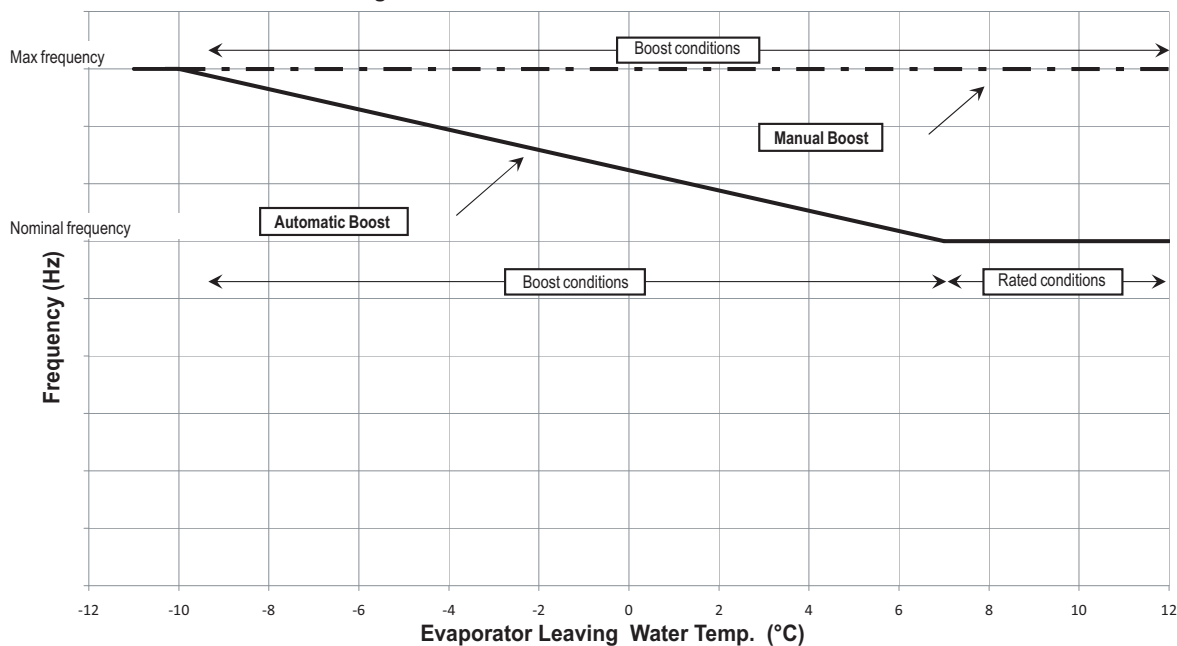

NOTES

1. Automatic boost: unit standard configuration
2. Manual boost: customized configuration by different settings
3. Rated conditions: compressors are working at nominal frequency
4. Boost conditions: compressors are working at the maximum frequency
5. Manual boost: customized configuration by different settings
6. Both automatic and manual boost maximum frequency depends on the maximum current suppliable by the inverter

OPL_1a-2-3-4a-5a-6a-7-8_Rev.03_6a

12 Operation range

12 - 1 Operation Range

2
12

Heating Capacity correction factors for different evaporator inlet air temperature and relative humidity conditions

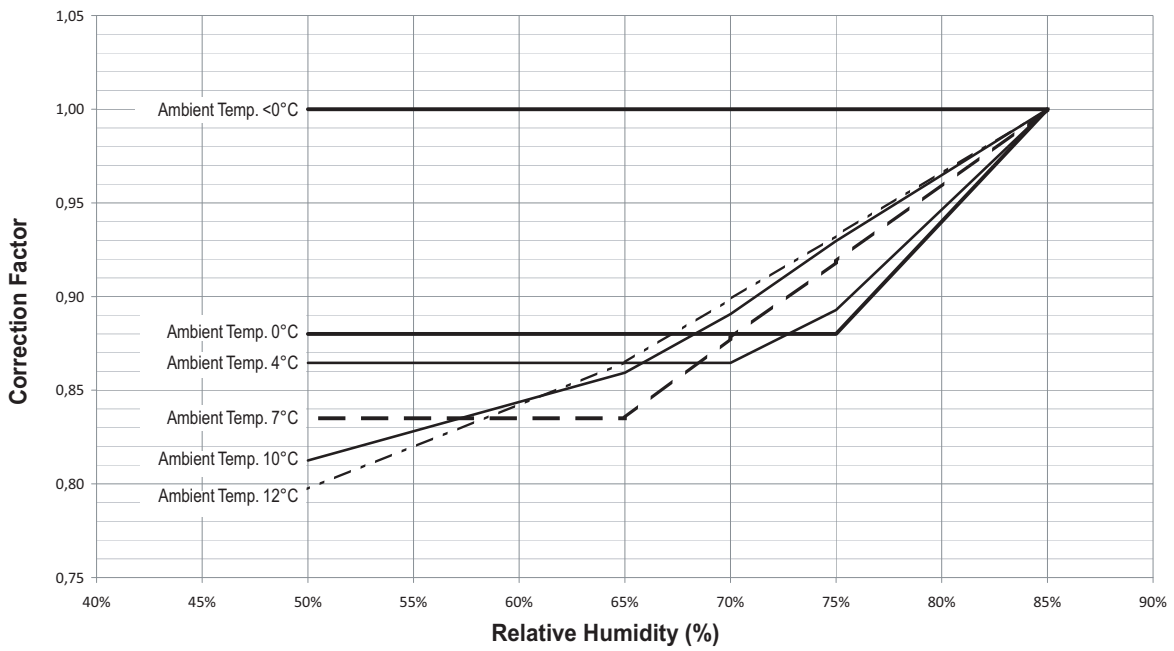

OPL_1a-2-3-4a-5a-6a-7-8_Rev.03_7

12 Operation range

12 - 1 Operation Range

Integrated Heating Capacity - Automatic Boost

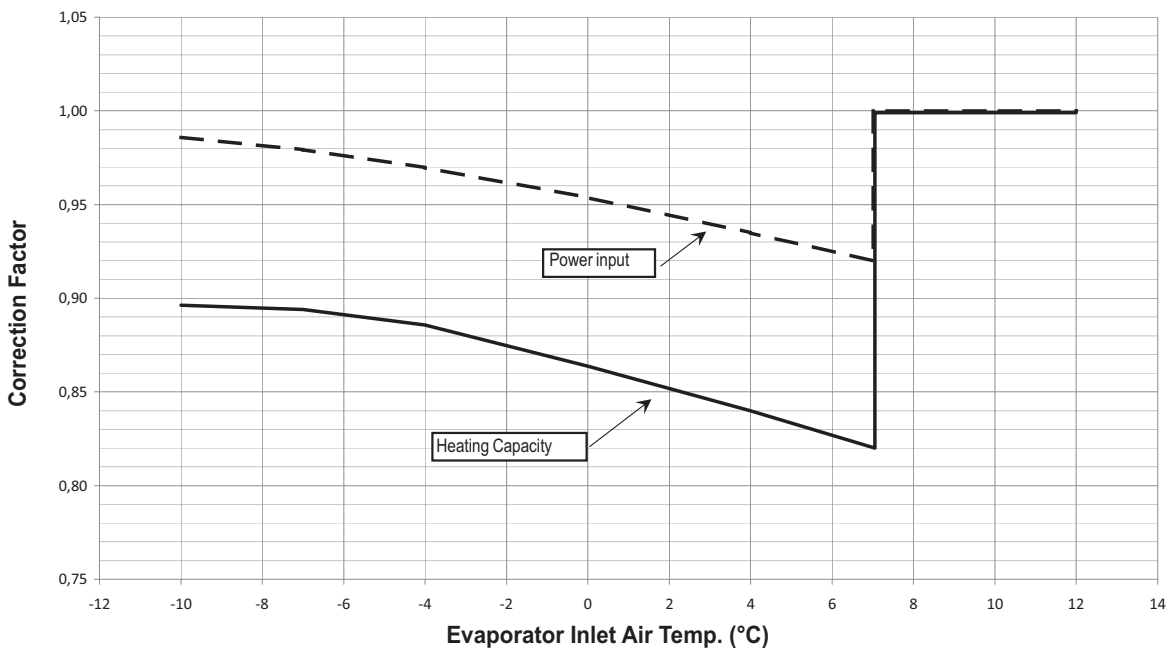

NOTES

- Correction factors to be applied to Standard Ratings in Heating Mode (Relative Humidity: 85% with evaporator inlet air temperature above 0°C ; 100% with evaporator inlet air temperature below 0°C)

Integrated Heating Capacity - Manual Boost

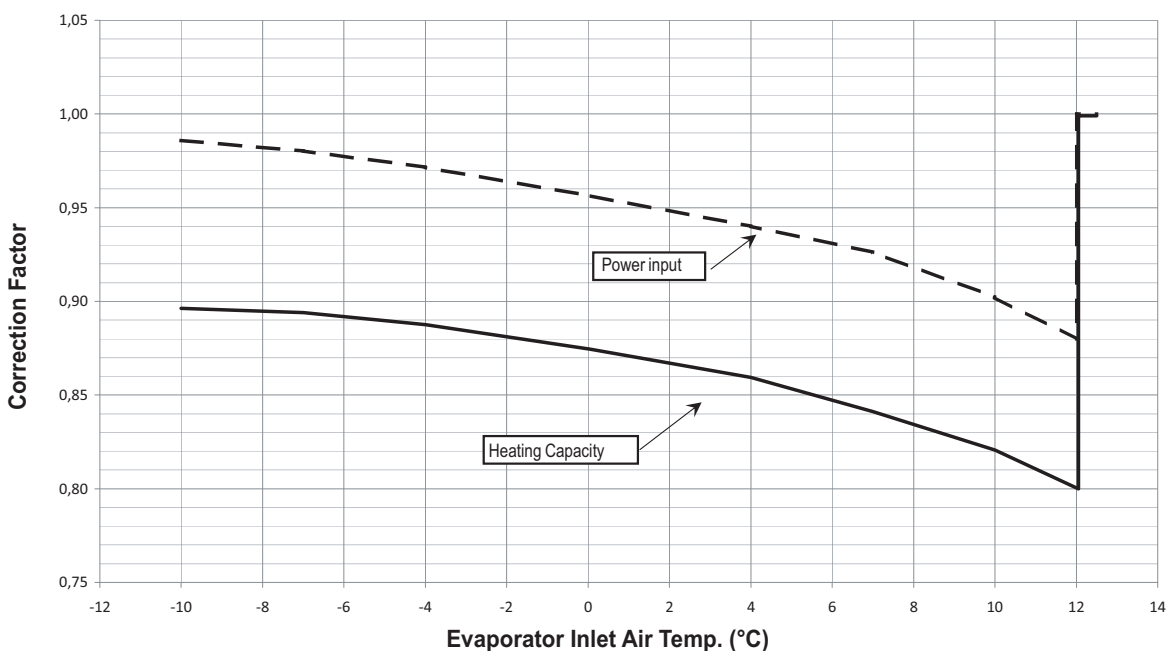

NOTES

- Correction factors to be applied to Standard Ratings in Heating Mode (Relative Humidity: 85% with evaporator inlet air temperature above 0°C ; 100% with evaporator inlet air temperature below 0°C)

13 Specification text

13 - 1 Specification Text

2
13

Technical Specification for Air Cooled Screw Chiller

GENERAL

The air to Water Heat Pump will be designed and manufactured in accordance with following European directives:

Rating of chillers	EN 12055
Construction of pressure vessel	97/23/EC (PED)
Machinery Directive	98/37/EC as modified
Low Voltage	2006/95/EC
Electromagnetic Compatibility	2004/108/EC
Electrical & Safety codes	EN 60204-1 / EN 60335-2-40
Manufacturing Quality Stds	UNI – EN ISO 9001:2000
Rating of chillers	EN 12055

The unit will be tested at full load in the factory at the nominal working conditions and water temperatures. Before shipment a full test will be held to avoid any losses.

Heat Pump will be delivered to the job site completely assembled and charged with right refrigerant and oil quantity.

Comply with the manufacturer instructions for rigging and handling equipment.

The unit will be able to start up and operate as standard at full load and outside air temperature from °C to °C with an evaporator leaving fluid temperature between °C and 15 °C

All unit's published performances have to be certified by **Eurovent**.

REFRIGERANT

Only HFC 134a will be accepted.

PERFORMANCE

- ✓ Number of air to water heat pumps:
- ✓ Cooling capacity for single air to water heat pump: kW
- ✓ Power input for single air to water heat pump in cooling mode: kW
- ✓ Shell & tube heat exchanger entering water temperature in cooling mode: °C
- ✓ Shell & tube heat exchanger leaving water temperature in cooling mode: °C
- ✓ Shell & tube heat exchanger water flow: l/s
- ✓ Nominal outside working ambient temperature in cooling mode: °C

- ✓ Heating capacity for single air to water heat pump: kW
- ✓ Power input for single air to water heat pump in heating mode: kW
- ✓ Shell & tube heat exchanger entering water temperature in heating mode: °C
- ✓ Shell & tube heat exchanger leaving water temperature in heating mode: °C
- ✓ Shell & tube heat exchanger water flow: l/s
- ✓ Nominal outside working ambient temperature in heating mode: °C

- ✓ The unit should work with electricity in range 400 V ±10%, 3ph, 50Hz without neutral and shall only have one power connection point. The control circuit voltage shall be 24 V maximum, supplied by a factory-installed transformer.

UNIT DESCRIPTION

The unit shall include as standard not less than: two or three independent refrigerant circuits, semi-hermetic rotary single screw compressors, air-cooled variable electrical frequency driver for each compressor (VFD), electronic expansion device (EEXV), refrigerant direct expansion shell & tube heat exchanger, air-cooled condenser section, R134a refrigerant, lubrication system, motor starting components, suction line shut-off valve, discharge line shut-off valve, control system and all components necessary for safe and stable unit operation.

The unit will be factory assembled on a robust base-frame made of zinc coated steel, protected by an epoxy paint.

SPC_1a-2a-3a-4a-5a_Rev.00_1

13 Specification text

13 - 1 Specification Text

NOISE LEVEL AND VIBRATIONS

Sound pressure level at 1 meter distance in free field, semispheric conditions, shall not exceeddB(A). The sound pressure levels must be rated in accordance to ISO 3744.

Other types of rating unacceptable. Vibration level should not exceed 2 mm/s.

DIMENSIONS

Unit dimensions shall not exceed following indications:

- ✓ unit length mm,
- ✓ unit width mm,
- ✓ unit height mm.

HEAT PUMP COMPONENTS

Compressors

- ✓ Semi-hermetic, single-screw type with one main helical rotor meshing with gaterotor. The gaterotor will be constructed of a carbon impregnated engineered composite material. The gaterotor supports will be constructed of cast iron.
- ✓ The oil injection shall be used in order to get high EER (Energy Efficiency Ratio) also at high condensing pressure and low sound pressure levels in each load condition.
- ✓ Refrigerant system differential pressure shall provide oil flow throught service replaceable, 0.5 micron, full flow, cartridge type oil filter internal to compressor.
- ✓ Refrigerant system differential pressure shall provide oil injection on all moving compressor parts to correctly lubricate them. Electrical oil pump lubricating system is not acceptable.
- ✓ The compressor's oil cooling must be realized, when necessary, by refrigerant liquid injection. External dedicated heat exchanger and additional piping to carry the oil from the compressor to heat exchanger and viceversa will be not accepted.
- ✓ The compressor shall be provided with an integrated, high efficiency, cyclonic type oil separator and with built-in oil filter, cartridge type.
- ✓ The compressor shall be direct electrical driven, without gear transmission between the screw and the electrical motor.
- ✓ The compressor casing shall be provided with ports to realize economized refrigerant cycles.
- ✓ Shall be present two thermal protection realized by a thermistor for high temperature protection: one temperature sensor to protect electrical motor and another sensor to protect unit and lubricating oil from high discharge gas temperature.
- ✓ The compressor shall be equipped with an electric oil-crankcase heater.
- ✓ Compressor shall be fully field serviceable. Compressor that must be removed and returned to the factory for service shall be unacceptable.

Cooling capacity control system

- ✓ Each unit will have a microprocessor for the control of compressor inverter position and the instantaneous RPM value of the motor.
- ✓ The unit capacity control shall be infinitely modulating, both in cooling and in heating mode, from 100% down to 30% for each compressor (from 100% down to 13% of full load for units with 2 compressors and down to 9% of full load for units with 3 compressors).
- ✓ Step unloading unacceptable because of evaporator leaving water temperature fluctuation and low unit efficiency at partial load.
- ✓ The system shall stage the unit based on the leaving evaporator water temperature that shall be controlled by a PID (Proportional Integral Derivative) loop.
- ✓ Unit control logic shall to manage frequency level of the compressor electric motor to exactly match plant load request in order to keep constant the set point for delivered chilled or hot water temperature.
- ✓ In this operating condition unit control logic shall modulate electrical frequency level in a range lower and upper the nominal electrical network value fixed at 50 Hz.

SPC_1a-2a-3a-4a-5a_Rev.00_2

13 Specification text

13 - 1 Specification Text

2
13

- ✓ The microprocessor unit control shall detect conditions that approach protective limits and take self-corrective action prior to an alarm occurring. The system shall automatically reduce chiller capacity when any of the following parameters are outside their normal operating range:
 - o High condenser pressure
 - o Low evaporation refrigerant temperature
 - o High compressor motor amps
- ✓ Air to water heat pump shall be able to deliver heating capacity (with -5°C outside ambient temperature) close to its nominal cooling capacity related at +35°C outside ambient temperature with +7°C for set-point of the leaving evaporator chilled water. In this condition unit shall be able to deliver 45°C hot water.

Unit-Mounted Variable Frequency Driver (VFD) and Electrical Requirement

- ✓ All interconnecting wiring between the VFD and the chiller shall be factory-installed. Customer electrical connection for compressor motor power shall be limited to main power leads to the single point power connection located into electrical panel.
- ✓ The VFD shall be air cooled type. Water cooled design or refrigerant cooled design are not acceptable.
- ✓ The VFD full load efficiency shall meet or exceed 97% at 100% VFD rated capacity.
- ✓ Base motor frequency shall permit motor to be utilized at nameplate voltage. Adjustable frequency range, monitored by unit's microprocessor control, shall permit a stable unit capacity control down to 13% (9% with 3 compressor unit) without hot-gas bypass.
- ✓ Starting current for the compressor shall not exceed nominal compressor load amps.
- ✓ Unit power factor shall be not less than 0.95 on entire unit capacity range, from 100% down to 13% (9% with 3 compressor unit).

Evaporator

- ✓ The units shall be supplied with shell and tubes counter-flow heat exchanger with single refrigerant pass. It will be refrigerant direct expansion type with refrigerant inside the tubes and water outside (shell side). It will include carbon steel tube sheets, with straight copper tubes internally wound for higher efficiencies, expanded on the tube plates.
- ✓ The external shell shall be linked with an electrical heater to prevent freezing down to -28°C ambient temperature, commanded by a thermostat and shall be insulated with flexible, closed cell polyurethane insulation material (10-mm thick).
- ✓ The evaporator will have 2 or 3 circuits, one for each compressor and shall be single refrigerant pass.
- ✓ The water connections shall be VICTAULIC type connections as standard to ensure quick mechanical disconnection between the unit and the hydronic network.
- ✓ Evaporator is manufactured in accordance to PED approval.

Condenser coil

- ✓ The condenser coils are constructed with internally finned seamless copper tubes having a "W" configuration and arranged in a staggered row pattern and mechanically expanded into lanced and rippled aluminium fins with full fin collars for higher efficiencies. The space between the fins are given by a collar that will increase the surface area in connection with the tubes, protecting them from ambient corrosion.
- ✓ The coils will have an integral subcooler circuit that provides sufficient subcooling to effectively eliminate the possibility of liquid flashing and increase the unit's efficiency of 5-7% without increasing in power absorption.
- ✓ The condenser coil shall be leak-tested and submitted to a pressure test with dry air.

Condenser fans

- ✓ The fans used in conjunction with the condenser coils, shall be propeller type with high efficiency design blades to maximize performances and lower noise. The material of the blades is glass reinforced resin and each fan is protected by a guard.
- ✓ The air discharge shall be vertical and each fan must be coupled to the electrical motor. Fan motor will be thermally protected (as standard) by internal thermal motor and protected by circuit breaker installed inside the electrical panel as a standard. The motor will be IP54.
- ✓ They shall have individual overload protection via a disconnect switch.

SPC_1a-2a-3a-4a-5a_Rev.00_3

13 Specification text

13 - 1 Specification Text

Refrigerant circuit

- ✓ The unit must have refrigerant circuits completely independent of each other with one compressor and one variable electrical frequency driver per circuit (VFD).
- ✓ Each circuit shall include as standard: electronic expansion device piloted by unit's microprocessor control, compressor discharge shut-off valve, suction line shut-off valve, 4-way valve to reverse refrigerant cycle into the unit, liquid line shut-off valve with charging connection, replaceable core filter-drier, sight glass with moisture indicator and insulated suction line.

Condensation control

- ✓ The units will be provided with an automatic control for condensing pressure which ensures the working at low external temperatures down to +10 °C, thanks the ON/OFF of the condenser fans, to maintain condensing pressure. Fan speed control, to allow unit's operation with very low ambient temperature (-18°C), should be available as option.
- ✓ Automatic compressor unloading when abnormal high condensing pressure is detected to prevent the shutdown of the refrigerant circuit (shutdown of the unit) due to a high-pressure fault.

Low Noise unit options (on request)

- ✓ The unit compressors shall be connected with unit's metal baseframe by rubber antivibration supports to prevent the transmission of vibrations to all metal unit structure and so to control the unit noise.
- ✓ The discharge and suction lines shall be provided with mufflers to eliminate vibration and so to reduce the noise unit emission.
- ✓ The chiller shall be provided with an acoustically compressor enclosure. This enclosure shall be realized with a light, corrosion resisting aluminium structure and metal panels. The compressors sound-proof enclosure shall be internally fitted with flexible, multi layer, high density materials. The middle layer is 3 mm, very high density and high efficiency noise reduction material. The enclosure shall be carefully assembled to avoid decreasing of its noise reduction power.
- ✓ The chiller shall be provided with very low speed condenser fans and with an improved condenser section.

13 Specification text

13 - 1 Specification Text

2
13

Control panel

- ✓ Field power connection, control interlock terminals, and unit control system should be centrally located in an electric panel (IP 54). Power and starting controls should be separate from safety and operating controls in different compartments of the same panel.
- ✓ Starting will be star/delta type.
- ✓ Power and starting controls should include fuses and contactors for each compressor winding and fan motors. Operating and safety controls should include energy saving control; emergency stop switch; overload protection for compressor motor; high and low pressure cut-out switch (for each refrigerant circuit); anti-freeze thermostat; cut-out switch for each compressor.
- ✓ All of the information regarding the unit will be reported on a display and with the internal built-in calendar and clock that will switch the unit ON/OFF during day time all year long.
- ✓ The following features and functions shall be included:
 - resetting chilled water temperature by controlling the return water temperature or by a remote 4-20 mA DC signal or by controlling the external ambient temperature;
 - soft load function to prevent the system from operating at full load during the chilled fluid pulldown period;
 - password protection of critical parameters of control;
 - start-to-start and stop-to-start timers to provide minimum compressor off-time with maximum motor protection;
 - communication capability with a PC or remote monitoring;
 - discharge pressure control through intelligent cycling of condenser fans;
 - lead-lag selection by manual or automatically by circuit run hours;
 - double set point for brine unit version;
 - scheduling via internal time clock to allow programming of a yearly start-stop schedule accommodating weekends and holidays.

Optional High Level Communications Interface

The controller as a minimum shall be capable of providing the data shown in the above list and document entitled McQuay-comms, using the following options:

- Option A RS485 Serial card
- Option B RS232 Serial card
- Option C LonWorks interface to FTT10A Transceiver
- Option D Bacnet Compatible



Daikin's unique position as a manufacturer of air conditioning equipment, compressors and refrigerants has led to its close involvement in environmental issues. For several years Daikin has had the intention to become a leader in the provision of products that have limited impact on the environment. This challenge demands the eco design and development of a wide range of products and an energy management system, resulting in energy conservation and a reduction of waste.



Daikin Europe NV, participates in the Eurovent Certification programme for Air conditioners (AC), Liquid Chilling Packages (LCP) and Fan coil units (FCU). Check ongoing validity of certificate online: www.eurovent-certification.com or using: www.certiflash.com

The present publication is drawn up by way of information only and does not constitute an offer binding upon Daikin Europe N.V. Daikin Europe N.V. has compiled the content of this publication to the best of its knowledge. No express or implied warranty is given for the completeness, accuracy, reliability or fitness for particular purpose of its content and the products and services presented therein. Specifications are subject to change without prior notice. Daikin Europe N.V. explicitly rejects any liability for any direct or indirect damage, in the broadest sense, arising from or related to the use and/or interpretation of this publication. All content is copyrighted by Daikin Europe N.V.

Daikin products are distributed by: