



Applied Systems Technical Data

Air cooled chiller, standard efficiency, extra low sound



EEDEN13-414

EWAD-D-SX

TABLE OF CONTENTS

EWAD-D-SX

1	Features	2
2	Specifications	3
	Technical Specifications	3
	Technical Specifications	3
	Electrical Specifications	4
	Electrical Specifications	5
3	Nomenclature	6
	Nomenclature	6
4	Capacity tables	7
	Cooling Capacity Tables	7
	Partial Heat Recovery Capacity tables	9
	Total Heat Recovery Capacity Tables	11
5	Dimensional drawings	12
	Dimensional Drawings	12
6	Sound data	14
	Sound Level Data	14
7	Installation	16
	Installation Method	16
8	Operation range	19
	Operation Range	19
9	Hydraulic performance	25
	Pump Characteristics	25
	Total Heat Recovery Pressure Drop	29
10	Specification text	30
	Specification Text	30

1 Features

- Standard efficiency version
- Extra low sound level configuration: condenser fan rotating at 500 rpm, rubber antivibration under compressor, compressor and evaporator sound enclosure
- Stepless single-screw compressor
- Optimised for use with R-134a
- MicroTech III controller
- Large operation range (ambient temperature down to -18°C)

1



2

2 Specifications

2-1 Technical Specifications					EWAD210D-SX	EWAD230D-SX	EWAD250D-SX	EWAD270D-SX	EWAD290D-SX	EWAD300D-SX
Cooling capacity	Nom.		kW	202 (1)	230 (1)	252 (1)	270 (1)	285 (1)	298 (1)	
Capacity control	Method		Stepless							
	Minimum capacity		%	13						
Power input	Cooling	Nom.	kW	80.8 (1)	86.0 (1)	94.4 (1)	105 (1)	115 (1)	127 (1)	
EER				2.50 (1)	2.68 (1)	2.67 (1)	2.56 (1)	2.47 (1)	2.35 (1)	
ESEER				3.24	3.50	3.39	3.42	3.32	3.27	
IPLV				3.82	4.08	3.99	4.02	3.92	3.84	
Casing	Colour		Ivory white							
	Material		Galvanized and painted steel sheet							
Dimensions	Unit	Height	mm	2,420						
		Width	mm	2,234						
		Depth	mm	3,139	4,040					
Weight	Unit		kg	3,110	3,475	3,425	3,430			
	Operation weight		kg	3,200	3,590					
Water heat exchanger	Type		Single pass shell & tube							
	Water volume		l	90	115	165	160			
	Nominal water flow	Cooling	l/s	9.7	11.0	12.1	12.9	13.7	14.3	
	Nominal water pressure drop	Cooling	Heat exchanger	kPa	45	34	38	35	38	
	Insulation material		Closed cell							
Air heat exchanger	Type		High efficiency fin and tube type with integral subcooler							
Fan	Quantity			6	8					
	Type		Direct propeller							
	Diameter		mm	710						
	Air flow rate	Nom.	l/s	12,876	17,893	17,169				
	Speed		rpm	500						
Fan motor	Drive		Direct on line							
	Input	Cooling	W	2,700	3,600					
Sound power level	Cooling	Nom.	dBA	84	85					
Sound pressure level	Cooling	Nom.	dBA	65						
Compressor	Type		Semi-hermetic single screw compressor							
	Quantity		2							
	Oil	Charged volume	l	26						
Operation range	Water side	Cooling	Min.	°CDB	-15					
			Max.	°CDB	15					
	Air side	Cooling	Min.	°CDB	-18					
			Max.	°CDB	48					
Refrigerant	Type		R-134a							
	Circuits	Quantity	2							
Refrigerant circuit	Charge		kg	56	60					
Piping connections	Evaporator water inlet/outlet (OD)			4"						
Safety devices	Item	01	High discharge pressure (pressure switch)							
		02	High discharge pressure (pressure transducer)							
		03	Low suction pressure (pressure transducer)							
		04	Compressor motor protection							
		05	High discharge temperature							
		06	Low oil pressure							
		07	Low pressure ratio							
		08	High oil filter pressure drop							
		09	Phase monitor							
		10	Water freeze protection controller							

2-2 Technical Specifications					EWAD310D-SX	EWAD370D-SX	EWAD410D-SX	EWAD450D-SX	EWAD490D-SX
Cooling capacity	Nom.		kW	308 (1)	369 (1)	412 (1)	449 (1)	490 (1)	
Capacity control	Method		Stepless						
	Minimum capacity		%	13					
Power input	Cooling	Nom.	kW	137 (1)	150 (1)	171 (1)	175 (1)	189 (1)	

2 Specifications

2-2 Technical Specifications					EWAD310D-SX	EWAD370D-SX	EWAD410D-SX	EWAD450D-SX	EWAD490D-SX
EER					2.25 (1)	2.46 (1)	2.41 (1)	2.56 (1)	2.60 (1)
ESEER					3.14	3.12	3.35	3.45	3.44
IPLV					3.69	4.03	3.90	3.96	3.89
Casing	Colour				Ivory white				
	Material				Galvanized and painted steel sheet				
Dimensions	Unit	Height		mm	2,420				
		Width		mm	2,234				
		Depth		mm	4,040		4,940		
Weight	Unit			kg	3,430	3,560	4,302	4,506	4,581
	Operation weight			kg	3,590	3,735	4,472	4,676	4,746
Water heat exchanger	Type				Single pass shell & tube				
	Water volume			l	160	175	170		165
	Nominal water flow	Cooling		l/s	14.7	17.7	19.7	21.5	23.5
	Nominal water pressure drop	Cooling	Heat exchanger	kPa	41	45	44	50	45
Insulation material					Closed cell				
Air heat exchanger	Type				High efficiency fin and tube type with integral subcooler				
Fan	Quantity				8		9	10	
	Type				Direct propeller				
	Diameter			mm	710	800			
	Air flow rate	Nom.	l/s		17,169	26,496		28,981	33,120
	Speed			rpm	500				
Fan motor	Drive				Direct on line				
	Input	Cooling	W		3,600	4,800		5,400	6,000
Sound power level	Cooling	Nom.	dBA		85			86	
Sound pressure level	Cooling	Nom.	dBA		65			66	
Compressor	Type				Semi-hermetic single screw compressor		asymmetric single screw compressor		
	Quantity				2				
	Oil	Charged volume		l	26	32			
Operation range	Water side	Cooling	Min.	°CDB	-15				
			Max.	°CDB	15				
	Air side	Cooling	Min.	°CDB	-18				
			Max.	°CDB	48				
Refrigerant	Type				R-134a				
	Circuits	Quantity			2				
Refrigerant circuit	Charge			kg	60	65	70	76	82
Piping connections	Evaporator water inlet/outlet (OD)				4"	5"			
Safety devices	Item	01			High discharge pressure (pressure switch)				
		02			High discharge pressure (pressure transducer)				
		03			Low suction pressure (pressure transducer)				
		04			Compressor motor protection				
		05			High discharge temperature				
		06			Low oil pressure				
		07			Low pressure ratio				
		08			High oil filter pressure drop				
		09			Phase monitor				
		10			Water freeze protection controller				

2-3 Electrical Specifications					EWAD210D-SX	EWAD230D-SX	EWAD250D-SX	EWAD270D-SX	EWAD290D-SX	EWAD300D-SX
Compressor	Phase				3~					
	Voltage			V	400					
	Voltage range	Min.		%	-10					
		Max.		%	10					
	Maximum running current			A	78		94		105	
Starting method					Wye-delta					
Compressor 2	Maximum running current			A	78	94		105		119

2 Specifications

2-3 Electrical Specifications			EWAD210D-SX	EWAD230D-SX	EWAD250D-SX	EWAD270D-SX	EWAD290D-SX	EWAD300D-SX	
Power supply	Phase		3~						
	Frequency		Hz						
	Voltage		V						
	Voltage range	Min.	%						
		Max.	%						
Unit	Maximum starting current		A	218	232	275	284	296	
	Nominal running current (RLA)	Cooling	A	135	143	157	173	188	204
	Maximum running current		A	163	182	199	209	220	235
	Max unit current for wires sizing		A	180	201	219	230	242	258
Fans	Nominal running current (RLA)		A	8	10				

Notes

- (1) Cooling: entering evaporator water temp. 12°C; leaving evaporator water temp. 7°C; ambient air temp. 35°C; full load operation.
- (2) Sound pressure levels are measured at entering evaporator water temp. 12°C; leaving evaporator water temp. 7°C; ambient air temp. 35°C; full load operation; Standard: ISO3744
- (3) Allowed voltage tolerance $\pm 10\%$. Voltage unbalance between phases must be within $\pm 3\%$.
- (4) Maximum starting current: starting current of biggest compressor + 75 % of maximum current of the other compressor + fans current for the circuit at 75 %
- (5) Nominal current in cooling mode: entering evaporator water temp. 12°C; leaving evaporator water temp. 7°C; ambient air temp. 35°C. Compressor + fans current.
- (6) Maximum running current is based on max compressor absorbed current in its envelope and max fans absorbed current
- (7) Maximum unit current for wires sizing is based on minimum allowed voltage.
- (8) Maximum current for wires sizing: (compressors full load ampere + fans current) x 1.1

2-4 Electrical Specifications			EWAD310D-SX	EWAD370D-SX	EWAD410D-SX	EWAD450D-SX	EWAD490D-SX	
Compressor	Phase		3~					
	Voltage		V					
	Voltage range	Min.	%					
		Max.	%					
	Maximum running current		A	119	140	153	174	
Starting method		Wye-delta						
Compressor 2	Maximum running current		A	119	140	153	174	
Power supply	Phase		3~					
	Frequency		Hz					
	Voltage		V					
	Voltage range	Min.	%					
		Max.	%					
Unit	Maximum starting current		A	296	406	457	475	
	Nominal running current (RLA)	Cooling	A	220	231	272	280	298
	Maximum running current		A	249	290	315	338	360
	Max unit current for wires sizing		A	274	319	347	371	395
Fans	Nominal running current (RLA)		A	10			11	13

Notes

- (1) Cooling: entering evaporator water temp. 12°C; leaving evaporator water temp. 7°C; ambient air temp. 35°C; full load operation.
- (2) Sound pressure levels are measured at entering evaporator water temp. 12°C; leaving evaporator water temp. 7°C; ambient air temp. 35°C; full load operation; Standard: ISO3744
- (3) Allowed voltage tolerance $\pm 10\%$. Voltage unbalance between phases must be within $\pm 3\%$.
- (4) Maximum starting current: starting current of biggest compressor + 75 % of maximum current of the other compressor + fans current for the circuit at 75 %
- (5) Nominal current in cooling mode: entering evaporator water temp. 12°C; leaving evaporator water temp. 7°C; ambient air temp. 35°C. Compressor + fans current.
- (6) Maximum running current is based on max compressor absorbed current in its envelope and max fans absorbed current
- (7) Maximum unit current for wires sizing is based on minimum allowed voltage.
- (8) Maximum current for wires sizing: (compressors full load ampere + fans current) x 1.1

3 Nomenclature

3 - 1 Nomenclature

3

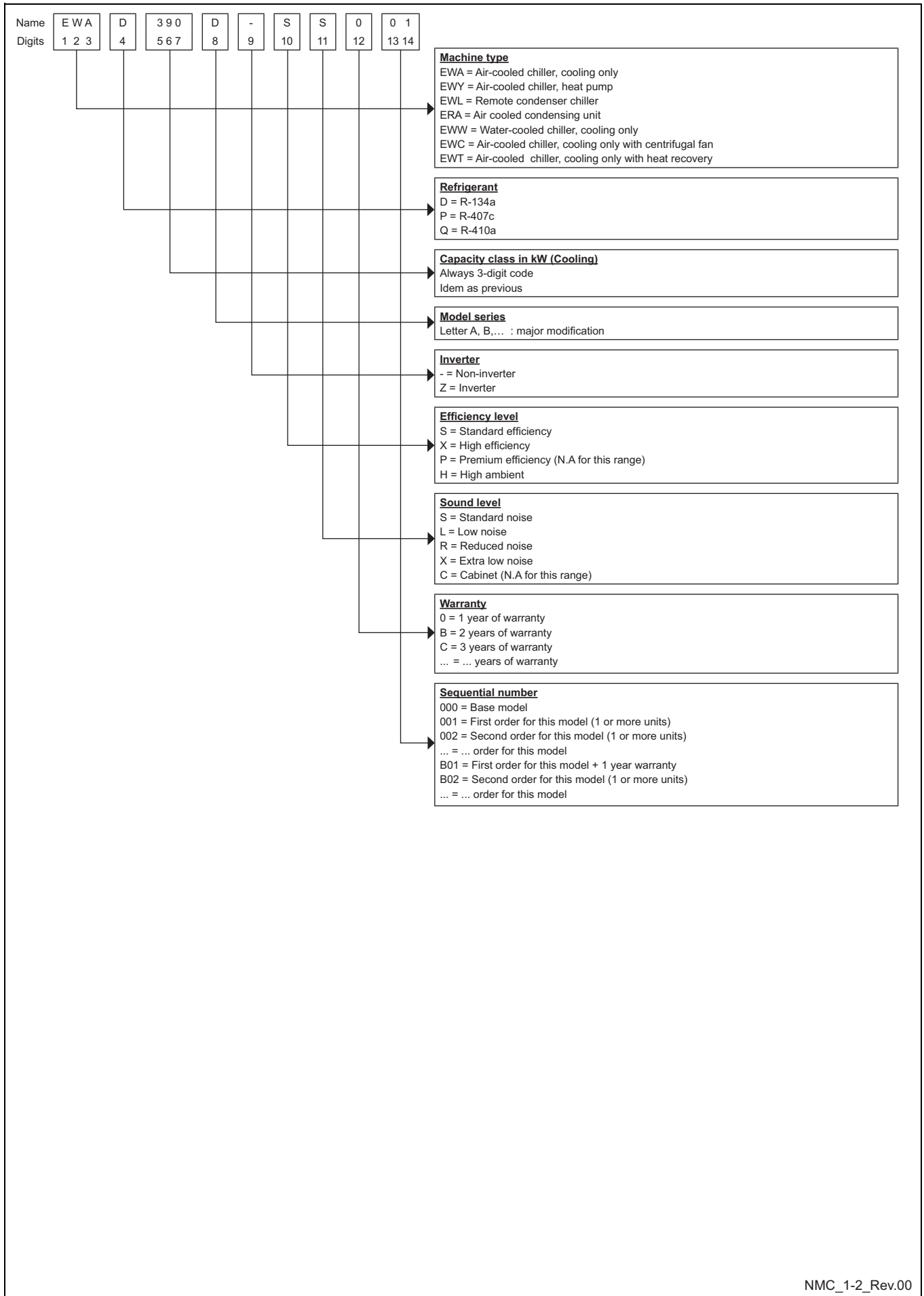

4 Capacity tables

4 - 1 Cooling Capacity Tables

EWAD210-300D-SX

Ta: Condenser inlet air temperature; Twout: Evaporator leaving water temperature ($\Delta t 5^{\circ}\text{C}$);
CC: Cooling capacity; PI: Power input; qw: Fluid flow rate; dpw: Fluid pressure drop

Size	Condenser inlet air temperature Ta	Twout																							
		5				7				9				11				13				15			
		CC	PI	qw	dpw	CC	PI	qw	dpw	CC	PI	qw	dpw	CC	PI	qw	dpw	CC	PI	qw	dpw	CC	PI	qw	dpw
210	25	212	66.1	10.1	49	224	68.4	10.8	54	237	70.9	11.4	60	250	73.4	12.0	66	263	76.0	12.7	73	277	78.7	13.3	80
	30	201	71.9	9.6	44	214	74.4	10.2	49	226	76.9	10.9	55	239	79.5	11.5	61	252	82.2	12.1	67	265	85.0	12.8	73
	35	190	78.3	9.1	40	202	80.8	9.7	45	214	83.3	10.3	50	227	86.0	10.9	55	239	88.8	11.5	61	252	91.7	12.1	67
	40	178	85	8.5	36	190	87.6	9.1	40	202	90.3	9.7	45	214	93.1	10.3	50	226	95.9	10.9	55	238	98.8	11.5	61
	43	171	89.3	8.2	33	182	92.0	8.7	37	194	94.7	9.3	42	206	97.5	9.9	46	210	94.6	10.1	48	213	91.3	10.2	49
	46	163	93.8	7.8	30	170	92.8	8.1	33	173	89.8	8.3	34	177	86.7	8.5	35	178	83.3	8.6	36	181	80.7	8.7	37
230	25	239	70.4	11.4	36	253	72.5	12.1	40	266	74.6	12.8	44	280	76.9	13.4	48	294	79.2	14.1	53	308	81.5	14.8	57
	30	228	76.7	10.9	33	242	79.0	11.6	37	255	81.3	12.2	41	269	83.6	12.9	45	282	86.0	13.6	49	296	88.4	14.2	54
	35	217	83.6	10.4	30	230	86.0	11.0	34	244	88.4	11.7	38	257	90.8	12.3	41	270	93.3	13.0	45	284	95.9	13.6	50
	40	205	91.1	9.8	27	218	93.5	10.4	31	231	96.0	11.1	34	244	98.6	11.7	38	258	101.0	12.4	42	271	104.0	13.0	46
	43	197	95.8	9.4	25	210	98.3	10.0	29	223	101.0	10.7	32	236	104.0	11.3	36	249	106.0	12.0	39	262	109.0	12.6	43
46	189	101.0	9.0	24	202	103.0	9.6	27	214	106.0	10.3	30	222	105.0	10.7	32	231	104.0	11.1	34	239	104.0	11.5	36	
250	25	262	77.2	12.5	41	276	79.5	13.2	45	290	81.8	13.9	49	304	84.2	14.6	54	319	86.7	15.3	59	334	89.4	16.1	64
	30	250	84.2	12.0	38	264	86.7	12.7	42	279	89.2	13.4	46	293	91.7	14.0	50	307	94.3	14.7	55	321	97.0	15.5	59
	35	238	91.9	11.4	34	252	94.4	12.1	38	266	97.0	12.7	42	280	99.7	13.4	46	294	102.0	14.1	51	308	105.0	14.8	55
	40	224	100.0	10.7	31	238	103.0	11.4	34	252	106.0	12.1	38	266	108.0	12.8	42	280	111	13.4	46	294	114	14.1	51
	43	216	105.0	10.3	29	230	108.0	11.0	32	243	111.0	11.7	36	257	114	12.3	40	271	117	13.0	44	285	120	13.7	48
	46	207	111.0	9.9	27	220	114	10.5	30	234	117	11.2	33	240	114	11.5	35	244	110	11.7	36	249	107	12.0	37
270	25	282	86.3	13.5	41	298	89.2	14.3	46	314	92.2	15.1	51	331	95.2	15.9	56	347	98.2	16.7	61	363	101.0	17.5	66
	30	269	94.0	12.8	38	285	97.0	13.6	42	301	100.0	14.4	47	317	103.0	15.2	51	333	107.0	16.0	56	349	110.0	16.8	61
	35	254	102.0	12.2	34	270	105.0	12.9	38	286	109.0	13.7	43	302	112.0	14.5	47	317	115.0	15.3	52	333	119.0	16.0	56
	40	239	111	11.4	31	254	115	12.2	34	270	118	12.9	38	285	121	13.7	43	301	125	14.5	47	315	127	15.1	51
	43	229	117	10.9	28	244	120	11.7	32	259	124	12.4	36	271	124	13.0	39	280	123	13.5	41	287	121	13.8	43
	46	216	121	10.3	26	226	120	10.8	28	235	119	11.2	30	239	115	11.4	31	242	111	11.6	32	246	108	11.8	33
290	25	300	94.6	14.3	38	318	98.0	15.2	42	336	102.0	16.1	47	355	105.0	17.0	52	374	109.0	18.0	57	393	113.0	18.9	63
	30	284	103.0	13.6	35	302	106.0	14.5	39	320	110.0	15.3	43	338	114.0	16.2	48	357	118.0	17.1	53	376	122.0	18.1	58
	35	268	112.0	12.8	31	285	115.0	13.7	35	303	119.0	14.5	39	320	123.0	15.4	43	339	127.0	16.3	48	357	132.0	17.1	53
	40	251	121	12.0	28	267	125	12.8	31	284	129	13.6	35	301	133	14.5	39	319	137	15.3	43	326	135	15.7	45
	43	240	127	11.5	25	256	131	12.2	29	271	134	13.0	32	276	130	13.3	33	281	125	13.5	34	284	121	13.6	35
	46	222	128	10.6	22	226	123	10.8	23	231	119	11.0	24	236	115	11.3	25	239	112	11.5	26	242	108	11.6	26
300	25	315	104.0	15.0	41	333	108.0	16.0	46	352	112.0	16.9	51	371	116.0	17.8	56	391	121.0	18.8	62	410	125.0	19.7	67
	30	298	113.0	14.3	38	316	117.0	15.2	42	335	122.0	16.1	47	354	126.0	17.0	51	372	130.0	17.9	57	391	135.0	18.8	62
	35	281	123	13.4	34	298	127	14.3	38	316	132	15.2	42	335	136	16.1	46	353	141	17.0	51	371	146	17.9	56
	40	262	134	12.5	30	279	138	13.4	33	297	142	14.2	37	307	141	14.7	40	319	141	15.3	43	325	138	15.6	44
	43	249	139	11.9	27	260	138	12.5	29	269	137	12.9	31	275	133	13.2	33	280	128	13.4	34	283	124	13.6	34
	46	221	131	10.5	22	226	126	10.8	23	229	122	11.0	23	234	118	11.2	24	237	115	11.4	25	240	111	11.5	26

NOTES - ANMERKUNGEN - Σημειώσεις - NOTAS - REMARQUES - NOTE - OPMERKINGEN - примечания

1 Fluid: Water
Fluid: Wasser
Υγρό: Νερό
Líquido: agua
Liquide: Eau
Fluido: Acqua
Vloeistof: Water
Жидкость: Вода

2 For working conditions where dpw values are in italic, please contact factory.
Für Arbeitsbedingungen mit kursiv gedruckten dpw-Werten, wenden Sie sich bitte an den Hersteller.
Για τις συνθήκες εργασίας όπου οι τιμές dpw είναι σε πλάγια γραφή, παρακαλούμε επικοινωνήστε με το εργοστάσιο.
Para las condiciones de funcionamiento en las que los valores dpw están en cursiva, póngase en contacto con la fábrica.
Pour les conditions de travail lorsque les valeurs dpw sont en italique, veuillez contacter l'usine.
Per le condizioni d'esercizio in cui i valori dpw sono riportati in corsivo, contattare il produttore.
Voor bedrijfsomstandigheden met schuingedrukte dpw-waarden, gelieve contact op te nemen met de fabriek.
Если условия работы соответствуют значениям dpw, указанным курсивом, обратитесь на завод-изготовитель.

4 Capacity tables

4 - 1 Cooling Capacity Tables

EWAD310-490D-SX

Ta: Condenser inlet air temperature; Twout: Evaporator leaving water temperature ($\Delta t 5^{\circ}\text{C}$);
CC: Cooling capacity; PI: Power input; qw: Fluid flow rate; dpw: Fluid pressure drop

Size	Condenser inlet air temperature Ta	Twout																							
		5				7				9				11				13				15			
		CC kW	PI kW	qw l/s	dpw kPa	CC kW	PI kW	qw l/s	dpw kPa	CC kW	PI kW	qw l/s	dpw kPa	CC kW	PI kW	qw l/s	dpw kPa	CC kW	PI kW	qw l/s	dpw kPa	CC kW	PI kW	qw l/s	dpw kPa
310	25	325	112.0	15.6	45	344	117.0	16.5	50	363	121.0	17.4	55	383	125.0	18.4	60	402	130.0	19.3	66	422	135.0	20.3	72
	30	308	122	14.7	41	327	126	15.6	45	345	131	16.6	50	364	136	17.5	55	383	141	18.4	61	402	146	19.3	66
	35	290	133	13.9	36	308	137	14.7	41	326	142	15.6	45	344	147	16.5	50	363	152	17.4	55	381	157	18.3	60
	40	270	144	12.9	32	287	148	13.8	36	305	153	14.6	40	310	147	14.8	41	314	142	15.1	42	320	138	15.4	44
	43	255	148	12.2	29	261	143	12.5	30	265	137	12.7	31	270	133	13.0	32	275	129	13.2	33	279	125	13.4	34
	46	216	131	10.3	21	222	128	10.6	23	224	122	10.7	23	230	120	11.0	24	232	115	11.1	24	235	112	11.3	25
370	25	390	121	18.6	49	411	125	19.7	54	433	129	20.8	60	455	134	21.8	65	477	138	22.9	71	499	143	24.0	78
	30	371	133	17.7	45	392	137	18.8	50	412	141	19.8	55	433	146	20.8	60	454	150	21.8	65	476	155	22.9	71
	35	349	145	16.7	40	369	150	17.7	45	388	154	18.6	49	408	159	19.6	54	428	164	20.6	59	448	169	21.5	64
	40	322	159	15.4	35	340	164	16.3	39	359	169	17.2	43	378	174	18.1	47	396	180	19.0	51	415	185	19.9	55
	43	303	169	14.5	31	321	174	15.4	35	339	179	16.2	38	357	184	17.1	42	373	188	17.9	46	378	180	18.2	47
	46	282	179	13.5	27	299	184	14.3	31	306	176	14.6	32	312	170	15.0	33	320	165	15.3	35	323	159	15.5	35
410	25	438	137	20.9	49	461	142	22.1	54	483	146	23.2	59	505	151	24.3	64	528	156	25.4	69	551	161	26.5	75
	30	416	151	19.9	45	438	155	21.0	49	460	160	22.1	54	482	165	23.1	59	503	170	24.2	63	525	175	25.3	69
	35	390	166	18.7	40	412	171	19.7	44	433	176	20.7	48	454	181	21.8	53	474	186	22.8	57	495	191	23.8	62
	40	360	183	17.2	34	380	188	18.2	38	400	193	19.2	42	420	198	20.2	46	433	197	20.8	48	435	187	20.9	49
	43	335	192	16.0	30	356	199	17.1	34	365	192	17.5	35	368	181	17.7	36	369	168	17.7	36	366	155	17.6	36
	46	287	176	13.7	23	303	177	14.5	25	309	168	14.8	26	310	156	14.9	27	306	141	14.7	26	293	123	14.0	24
450	25	473	141	22.7	55	497	145	23.8	60	521	150	25.0	66	546	154	26.2	71	570	159	27.4	77	595	164	28.7	84
	30	452	155	21.6	51	475	159	22.8	55	499	164	23.9	61	522	168	25.1	66	545	173	26.2	71	569	179	27.4	77
	35	426	171	20.4	46	449	175	21.5	50	472	180	22.6	55	494	185	23.7	60	517	190	24.8	65	539	195	25.9	70
	40	396	189	18.9	40	418	193	20.0	44	440	198	21.1	48	461	203	22.1	53	483	208	23.2	57	498	209	24.0	61
	43	375	201	17.9	36	396	206	19.0	40	415	209	19.9	44	429	206	20.6	46	435	198	20.9	48	436	186	21.0	48
	46	331	194	15.8	29	352	199	16.9	32	361	192	17.3	34	363	179	17.4	34	361	165	17.3	34	351	147	16.9	32
490	25	517	152	24.7	49	544	157	26.1	54	572	162	27.4	59	600	168	28.8	65	629	173	30.2	71	657	179	31.6	77
	30	493	167	23.6	45	520	172	24.9	50	546	177	26.2	55	573	182	27.5	60	600	188	28.8	65	627	194	30.2	70
	35	464	184	22.2	41	490	189	23.5	45	516	194	24.7	49	541	200	26.0	54	567	205	27.3	59	593	211	28.5	64
	40	431	203	20.6	35	455	208	21.8	39	480	213	23.0	43	505	219	24.2	47	529	225	25.4	52	554	231	26.6	56
	43	407	215	19.5	32	431	220	20.6	36	456	226	21.8	39	473	226	22.7	42	476	214	22.9	43	474	199	22.8	42
	46	365	214	17.4	26	388	218	18.5	29	394	207	18.9	30	398	195	19.1	31	393	177	18.8	30	381	158	18.3	29

NOTES - ANMERKUNGEN - Σημειώσεις - NOTAS - REMARQUES - NOTE - OPMERKINGEN - примечания

- 1 Fluid: Water
Fluid: Wasser
Υγρό: Νερό
Líquido: agua
Liquide: Eau
Fluido: Acqua
Vloeistof: Water
Жидкость: Вода
- 2 For working conditions where dpw values are in italic, please contact factory.
Für Arbeitsbedingungen mit kursiv gedruckten dpw-Werten, wenden Sie sich bitte an den Hersteller.
Για τις συνθήκες εργασίας όπου οι τιμές dpw είναι σε πλάγια γραφή, παρακαλούμε επικοινωνήστε με το εργοστάσιο.
Para las condiciones de funcionamiento en las que los valores dpw están en cursiva, póngase en contacto con la fábrica.
Pour les conditions de travail lorsque les valeurs dpw sont en italique, veuillez contacter l'usine.
Per le condizioni d'esercizio in cui i valori dpw sono riportati in corsivo, contattare il produttore.
Voor bedrijfsomstandigheden met schuingedrukte dpw-waarden, gelieve contact op te nemen met de fabriek.
Если условия работы соответствуют значениям dpw, указанным курсивом, обратитесь на завод-изготовитель.

SRC_1-2-3-4-5-6-7_Rev.01_4_(2-2)

4 Capacity tables

4 - 2 Partial Heat Recovery Capacity tables

Partial Heat Recovery Ratings EWAD-D-S

EWC / LWC	*Model EWAD-D-SS*	Cc (kW)	Pi (kW)	Hc (kW)	% Hc	EER Hc
50/60	390	332	161	173	35%	3.13
	440	373	172	191	35%	3.27
	470	403	189	207	35%	3.24
	510	432	206	223	35%	3.18
	530	461	219	238	35%	3.19
	560	486	233	216	30%	3.01
	580	508	225	191	26%	3.10

EWC / LWC	*Model EWAD-D-SL*	*Model EWAD-D-SR*	Cc (kW)	Pi (kW)	Hc (kW)	% Hc	EER Hc
50/60	180	180	159	80.0	84	35%	3.03
	200	190	171	78.4	87	35%	3.30
	230	220	196	83.3	98	35%	3.52
	250	240	213	92.2	107	35%	3.48
	260	250	227	105	116	35%	3.28
	280	270	240	112	123	35%	3.23
	300	280	259	124	134	35%	3.18
	320	310	281	128	123	30%	3.15
	370	370	329	141	122	26%	3.20
	400	400	373	172	191	35%	3.27
	440	440	403	189	207	35%	3.24
	480	480	432	206	223	35%	3.18
	510	510	461	219	238	35%	3.19
	530	530	486	233	216	30%	3.01

EWC / LWC	*Model EWAD-D-SX*	Cc (kW)	Pi (kW)	Hc (kW)	% Hc	EER Hc
50/60	210	171	78.4	87	35%	3.30
	230	196	83.3	98	35%	3.52
	250	213	92.2	107	35%	3.48
	270	227	105	116	35%	3.28
	290	240	112	123	35%	3.23
	300	259	124	134	35%	3.18
	310	281	128	123	30%	3.15
	370	332	161	173	35%	3.13
	410	373	172	191	35%	3.27
	450	403	189	207	35%	3.24
	490	432	206	223	35%	3.18

NOTES

- Cc (cooling capacity)
- Pi (unit power input)
- Hc (heating heat recovery capacity)
- %Hc (percentage heat recovered)
- EER Hc (coefficient of performance during heat recovery = (cooling+ heating capacity) / power input)
- EWC (Entering water heat recovery condenser)
- LWC (Leaving water heat recovery condenser)

Data refers to:
 LWE (Leaving water evaporator) = 7°C
 Same evaporator flow as for nominal cooling operation
 Condenser Inlet Air Temperature = 35°C
 0.0176 m² °C/kW evaporator fouling factor

4 Capacity tables

4 - 2 Partial Heat Recovery Capacity tables

Partial Total Heat Recovery pressure drops

EWAD-D-SS	390	440	470	510	530	560	580
Heating Capacity (kW)	427	473	515	555	592	552	488
Water Flow (l/s)	20.41	22.59	24.61	26.52	28.28	26.36	23.33
Heat Recovery Pressure Drops (kPa)	37	13	15	17	19	14	11

NOTES

Water flow and pressure drop referred to nominal condition: evaporator water in/out: 12/7°C – saturated discharge temperature 45°C – water heat recovery in/out 40/45°C

EWAD-D-SL	180	200	230	250	260	280	300	320	370	400	440	480	510	530
EWAD-D-SR	180	190	220	240	250	270	280	310	370	400	440	480	510	530
Heating Capacity (kW)	207	216	243	265	289	306	333	314	314	473	515	555	592	552
Water Flow (l/s)	9.89	10.34	11.59	12.68	13.82	14.63	15.91	15.00	14.98	22.59	24.61	26.52	28.28	26.36
Heat Recovery Pressure Drops (kPa)	23	25	28	28	31	31	35	26	23	13	15	17	19	14

NOTES

Water flow and pressure drop referred to nominal condition: evaporator water in/out: 12/7°C – saturated discharge temperature 45°C – water heat recovery in/out 40/45°C

EWAD-D-SX	210	230	250	270	290	300	310	370	410	450	490
Heating Capacity (kW)	216	243	265	289	306	333	314	427	473	515	555
Water Flow (l/s)	10.34	11.59	12.68	13.82	14.63	15.91	15.00	20.41	22.59	24.61	26.52
Heat Recovery Pressure Drops (kPa)	25	28	28	31	31	35	26	37	13	15	17

NOTES

Water flow and pressure drop referred to nominal condition: evaporator water in/out: 12/7°C – saturated discharge temperature 45°C – water heat recovery in/out 40/45°C

OPT_1-2-3-4-5a-6-7-8_Rev.01_3 (1/3)

Partial Heat Recovery pressure drops

EWAD-D-SS	390	440	470	510	530	560	580
Heating Capacity (kW)	173	191	207	223	238	216	191
Water Flow (l/s)	8.25	9.12	9.90	10.67	11.38	10.30	9.11
Heat Recovery Pressure Drops (kPa)	7	2	3	3	3	2	2

NOTES

Water flow and pressure drop referred to nominal condition: evaporator water in/out: 12/7°C – condenser air inlet 35°C – water heat recovery in/out 50/60°C

EWAD-D-SL	180	200	230	250	260	280	300	320	370	400	440	480	510	530
EWAD-D-SR	180	190	220	240	250	270	280	310	370	400	440	480	510	530
Heating Capacity (kW)	84	87	98	107	116	123	134	123	122	191	207	223	238	216
Water Flow (l/s)	4.00	4.17	4.67	5.11	5.55	5.88	6.40	5.86	5.84	9.12	9.90	10.67	11.38	10.30
Heat Recovery Pressure Drops (kPa)	4	5	5	6	6	6	7	5	4	2	3	3	3	2

NOTES

Water flow and pressure drop referred to nominal condition: evaporator water in/out: 12/7°C – condenser air inlet 35°C – water heat recovery in/out 50/60°C

EWAD-D-SX	210	230	250	270	290	300	310	370	410	450	490
Heating Capacity (kW)	87	98	107	116	123	134	123	173	191	207	223
Water Flow (l/s)	4.17	4.67	5.11	5.55	5.88	6.40	5.86	8.25	9.12	9.90	10.67
Heat Recovery Pressure Drops (kPa)	5	5	6	6	6	7	5	7	2	3	3

NOTES

Water flow and pressure drop referred to nominal condition: evaporator water in/out: 12/7°C – condenser air inlet 35°C – water heat recovery in/out 50/60°C

OPT_1-2-3-4-5a-6-7-8_Rev.01_4 (1/3)

4 Capacity tables

4 - 3 Total Heat Recovery Capacity Tables

Total Heat Recovery Ratings EWAD-D-S

EWC / LWC	*Model EWAD-D-SS*	Cc (kW)	Pi (kW)	Hc (kW)	% Hc	EER Hc
40/45	390	348	154	427	85%	5.02
	440	391	165	473	85%	5.23
	470	423	183	515	85%	5.13
	510	453	200	555	85%	5.05
	530	484	213	592	85%	5.06
	560	510	226	552	75%	4.70
	580	533	219	488	65%	4.67
40/50	390	332	156	415	85%	4.79
	440	373	167	459	85%	4.99
	470	403	185	500	85%	4.89
	510	432	202	539	85%	4.81
	530	461	215	575	85%	4.82
	560	486	228	536	75%	4.47
	580	508	221	474	65%	4.44
45/55	390	332	158	294	60%	3.97
	440	373	169	325	60%	4.13
	470	403	187	354	60%	4.06
	510	432	204	382	60%	3.99
	530	461	217	407	60%	4.00
	560	486	231	358	50%	3.66
	580	508	223	314	43%	3.68

EWC / LWC	*Model EWAD-D-SL*	*Model EWAD-D-SR*	Cc (kW)	Pi (kW)	Hc (kW)	% Hc	EER Hc
40/45	180	180	167	76.7	207	85%	4.88
	200	190	179	75.1	216	85%	5.27
	230	220	205	80.0	243	85%	5.60
	250	240	224	88.4	265	85%	5.54
	260	250	238	102	289	85%	5.19
	280	270	251	109	306	85%	5.12
	300	280	272	120	333	85%	5.04
	320	310	294	124	314	75%	4.89
	370	370	345	137	314	65%	4.81
	400	400	391	165	473	85%	5.23
	440	440	423	183	515	85%	5.13
	480	480	453	200	555	85%	5.05
	510	510	484	213	592	85%	5.06
	530	530	510	226	552	75%	4.70
	40/50	180	180	159	77.5	201	85%
200		190	171	75.9	210	85%	5.02
230		220	196	80.8	235	85%	5.33
250		240	213	89.3	257	85%	5.27
260		250	227	103	281	85%	4.94
280		270	240	110	297	85%	4.88
300		280	259	121	323	85%	4.81
320		310	281	125	305	75%	4.66
370		370	329	138	304	65%	4.58
400		400	373	167	459	85%	4.99
440		440	403	185	500	85%	4.89
480		480	432	202	539	85%	4.81
510		510	461	215	575	85%	4.82
530		530	486	228	536	75%	4.47
45/55		180	180	159	78.4	143	60%
	200	190	171	76.8	149	60%	4.16
	230	220	196	81.7	167	60%	4.43
	250	240	213	90.4	182	60%	4.38
	260	250	227	104	199	60%	4.11
	280	270	240	111	210	60%	4.05
	300	280	259	122	229	60%	3.99
	320	310	281	127	204	50%	3.82
	370	370	329	140	202	43%	3.80
	400	400	373	169	325	60%	4.13
	440	440	403	187	354	60%	4.06
	480	480	432	204	382	60%	3.99
	510	510	461	217	407	60%	4.00
	530	530	486	231	358	50%	3.66

EWC / LWC	*Model EWAD-D-SX*	Cc (kW)	Pi (kW)	Hc (kW)	% Hc	EER Hc
40/45	210	179	75.1	216	85%	5.27
	230	205	80.0	243	85%	5.60
	250	224	88.4	265	85%	5.54
	270	238	102	289	85%	5.19
	290	251	109	306	85%	5.12
	300	272	120	333	85%	5.04
	310	294	124	314	75%	4.89
	370	348	154	427	85%	5.02
	410	391	165	473	85%	5.23
	450	423	183	515	85%	5.13
40/50	210	171	75.9	210	85%	5.02
	230	196	80.8	235	85%	5.33
	250	213	89.3	257	85%	5.27
	270	227	103	281	85%	4.94
	290	240	110	297	85%	4.88
	300	259	121	323	85%	4.81
	310	281	125	305	75%	4.66
	370	332	156	415	85%	4.79
	410	373	167	459	85%	4.99
	450	403	185	500	85%	4.89
45/55	210	171	76.8	149	60%	4.16
	230	196	81.7	167	60%	4.43
	250	213	90.4	182	60%	4.38
	270	227	104	199	60%	4.11
	290	240	111	210	60%	4.05
	300	259	122	229	60%	3.99
	310	281	127	204	50%	3.82
	370	332	158	294	60%	3.97
	410	373	169	325	60%	4.13
	450	403	187	354	60%	4.06

NOTES

- Cc (cooling capacity)
- Pi (unit power input)
- Hc (heating heat recovery capacity)
- %Hc (percentage heat recovered)
- EER Hc (coefficient of performance during heat recovery = (cooling+ heating capacity) / power input)
- EWC (Entering water heat recovery condenser)
- LWC (Leaving water heat recovery condenser)

Data refers to:
 LW/E (Leaving water evaporator) = 7°C
 Same evaporator flow as for nominal cooling operation
 Condenser Inlet Air Temperature = 35°C
 0.0176 m² °C/kW evaporator fouling factor

5 Dimensional drawings

5 - 1 Dimensional Drawings

Dimensions EWAD~D-

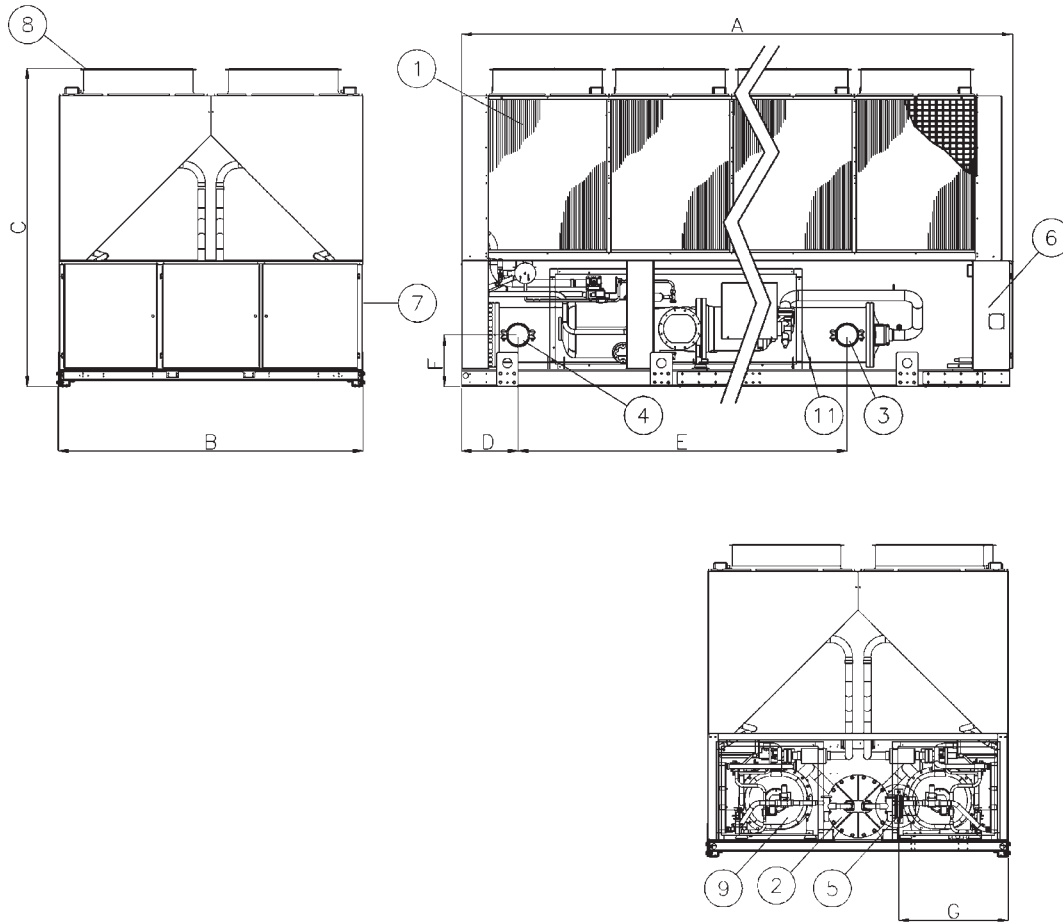

Models	Dimensions (mm)						
EWAD	A	B	C	D	E	F	G
EWAD390D-SS	3139	2234	2223	392	1875	339	873
EWAD440~580D-SS	4040	2234	2223	392	2450	339	855
EWAD230~300D-SL	3139	2234	2355	374	1911	339	873
EWAD320D-SL	4040	2234	2355	374	2486	339	873
EWAD400~530D-SL	4040	2234	2223	392	2450	339	855
EWAD220~280D-SR	3139	2234	2355	374	1911	339	873
EWAD310D-SR	4040	2234	2355	374	2486	339	873
EWAD400~530D-SR	4040	2234	2223	392	2450	339	855
EWAD210D-SX	3139	2234	2420	374	1911	339	873
EWAD230~310D-SX	4040	2234	2420	374	2486	339	873
EWAD370~490D-SX	4040	2234	2420	392	2450	339	873
EWAD250D-XS	3138	2234	2355	374	1911	339	873
EWAD280~400D-XS	4040	2234	2355	374	2486	339	873
EWAD470D-XS	4040	2234	2223	414	2412	379	873
EWAD520~620D-XS	4940	2234	2223	414	2412	379	815
EWAD240D-XR	3138	2234	2355	374	1911	339	873
EWAD270~390D-XR	4040	2234	2355	374	2486	339	873
EWAD460D-XR	4040	2234	2223	414	2412	379	873
EWAD510~600D-XR	4940	2234	2223	414	2412	379	815
EWAD230~310D-HS	3339	2234	2223	374	1911	339	873
EWAD340~380D-HS	4040	2234	2223	374	2486	339	873
EWAD420~590D-HS	4040	2234	2223	392	2450	339	873

LEGEND

- 1 – Condenser Coil
- 2 – Water heat exchanger (evaporator)
- 3 – Evaporator water inlet
- 4 – Evaporator water outlet
- 5 – Victaulic connection
- 6 – Operating and control panel
- 7 – Slot for power and control connection
- 8 – Fan
- 9 – Compressor

5 Dimensional drawings

5 - 1 Dimensional Drawings

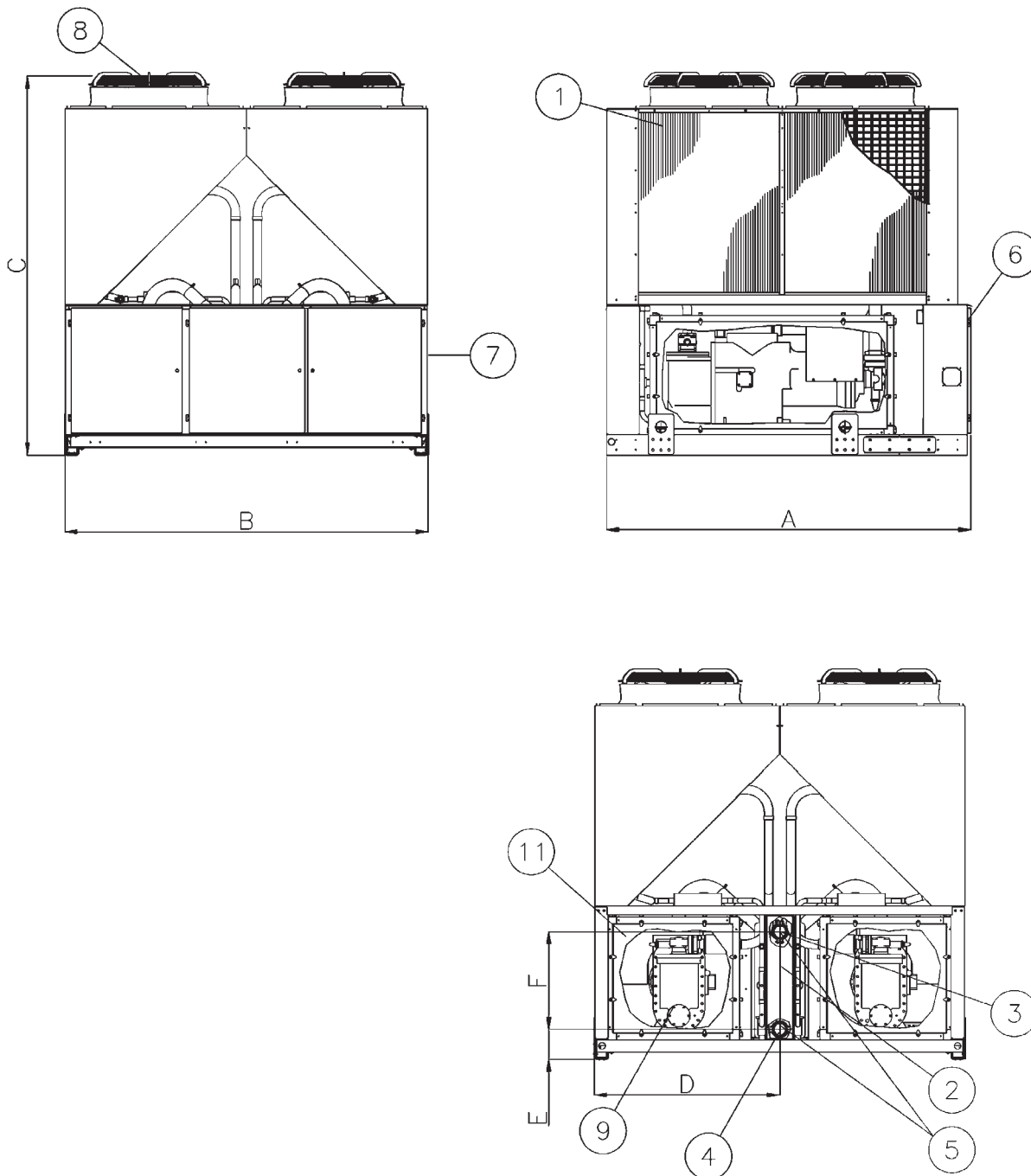

Models	Dimensions (mm)					
	A	B	C	D	E	F
EWAD180~200D-SL	2239	2234	2355	1117	181	590
EWAD180~190D-SR	2239	2234	2355	1117	181	590
EWAD200~210D-HS	2223	2234	2223	1117	181	590

LEGEND

- 1 – Condenser Coil
- 2 – Water heat exchanger (evaporator)
- 3 – Evaporator water inlet
- 4 – Evaporator water outlet
- 5 – Victaulic connection
- 6 – Operating and control panel
- 7 – Slot for power and control connection
- 8 – Fan
- 9 – Compressor

DMN_1a-2a_Rev.01_2

6 Sound data

6 - 1 Sound Level Data

6

EWAD-D-SX

Unit size	Sound pressure level at 1 m from the unit in semispheric free field (rif. 2 x 10 ⁻⁵ Pa)									Power
	63 Hz	125 Hz	250 Hz	500 Hz	1000 Hz	2000 Hz	4000 Hz	8000 Hz	dB(A)	dB(A)
210	68.5	60.1	65.1	65.1	57.9	55.4	42.3	35.8	65.0	84.3
230	68.5	60.1	65.1	65.1	57.9	55.4	42.3	35.8	65.0	84.7
250	68.5	60.1	65.1	65.1	57.9	55.4	42.3	35.8	65.0	84.7
270	68.5	60.1	65.1	65.1	57.9	55.4	42.3	35.8	65.0	84.7
290	68.5	60.1	65.1	65.1	57.9	55.4	42.3	35.8	65.0	84.7
300	68.5	60.1	65.1	65.1	57.9	55.4	42.3	35.8	65.0	84.7
310	68.5	60.1	65.1	65.1	57.9	55.4	42.3	35.8	65.0	84.7
370	62.0	60.0	63.5	63.0	60.0	58.0	47.0	36.5	65.0	84.7
410	62.0	60.0	63.5	63.0	60.0	58.0	47.0	36.5	65.0	84.7
450	63.5	59.5	63.5	62.5	60.5	59.5	46.5	37.0	65.5	85.7
490	62.0	59.0	64.0	65.0	59.5	59.0	50.5	39.5	66.0	86.2

NOTES

The values are according to ISO 3744 and are referred to: evaporator 12/7° C, air ambient 35° C, full load operation

EWAD-D-XS

Unit size	Sound pressure level at 1 m from the unit in semispheric free field (rif. 2 x 10 ⁻⁵ Pa)									Power
	63 Hz	125 Hz	250 Hz	500 Hz	1000 Hz	2000 Hz	4000 Hz	8000 Hz	dB(A)	dB(A)
250	79.5	74.9	72.9	79.2	68.7	65.9	57.3	51.4	77.5	96.8
280	79.5	74.9	72.9	79.2	68.7	65.9	57.3	51.4	77.5	97.2
300	79.5	74.9	72.9	79.2	68.7	65.9	57.3	51.4	77.5	97.2
330	79.5	74.9	72.9	79.2	68.7	65.9	57.3	51.4	77.5	97.2
350	79.5	74.9	72.9	79.2	68.7	65.9	57.3	51.4	77.5	97.2
380	81.0	76.4	74.4	80.7	70.2	67.4	58.8	52.9	79.0	98.7
400	81.0	76.4	74.4	80.7	70.2	67.4	58.8	52.9	79.0	98.7
470	64.5	73.5	73.0	78.5	71.5	73.0	60.0	53.0	79.0	98.7
520	64.5	73.5	73.5	78.5	71.5	73.0	60.0	53.0	79.0	99.2
580	64.5	73.5	73.5	78.5	71.6	73.1	60.0	53.0	79.0	99.2
620	64.5	73.5	73.5	78.5	71.5	73.0	60.0	53.0	79.0	99.2

NOTES

The values are according to ISO 3744 and are referred to: evaporator 12/7° C, air ambient 35° C, full load operation

EWAD-D-XR

Unit size	Sound pressure level at 1 m from the unit in semispheric free field (rif. 2 x 10 ⁻⁵ Pa)									Power
	63 Hz	125 Hz	250 Hz	500 Hz	1000 Hz	2000 Hz	4000 Hz	8000 Hz	dB(A)	dB(A)
240	78.9	72.4	69.2	73.4	65.6	61.2	54.2	47.4	72.5	91.8
270	78.9	72.4	69.2	73.4	65.6	61.2	54.2	47.4	72.5	92.2
300	78.9	72.4	69.2	73.4	65.6	61.2	54.2	47.4	72.5	92.2
320	78.9	72.4	69.2	73.4	65.6	61.2	54.2	47.4	72.5	92.2
350	78.9	72.4	69.2	73.4	65.6	61.2	54.2	47.4	72.5	92.2
370	79.1	73.4	70.2	74.4	66.6	62.2	55.2	48.4	73.5	93.2
390	79.1	73.4	70.2	74.4	66.6	62.2	55.2	48.4	73.5	93.2
460	59.0	68.0	67.5	73.0	66.0	67.5	54.5	47.5	73.5	93.2
510	59.0	68.0	68.0	73.0	66.0	67.5	54.5	47.5	73.5	93.7
560	59.0	68.0	68.0	73.0	66.1	67.6	54.5	47.5	73.5	93.7
600	59.0	68.0	68.0	73.0	66.0	67.5	54.5	47.5	73.5	93.7

NOTES

The values are according to ISO 3744 and are referred to: evaporator 12/7° C, air ambient 35° C, full load operation

6 Sound data

6 - 1 Sound Level Data

EWAD-D-SX

Unit size	Distance						
	1m	5m	10m	15m	20m	25m	50m
210	0.0	-8.0	-12.8	-15.9	-18.2	-20.0	-25.7
230	0.0	-7.7	-12.4	-15.5	-17.8	-19.6	-25.3
250	0.0	-7.7	-12.4	-15.5	-17.8	-19.6	-25.3
270	0.0	-7.7	-12.4	-15.5	-17.8	-19.6	-25.3
290	0.0	-7.7	-12.4	-15.5	-17.8	-19.6	-25.3
300	0.0	-7.7	-12.4	-15.5	-17.8	-19.6	-25.3
310	0.0	-7.7	-12.4	-15.5	-17.8	-19.6	-25.3
370	0.0	-7.7	-12.4	-15.5	-17.8	-19.6	-25.3
410	0.0	-7.7	-12.4	-15.5	-17.8	-19.6	-25.3
450	0.0	-7.4	-12.1	-15.2	-17.4	-19.2	-24.9
490	0.0	-7.4	-12.1	-15.2	-17.4	-19.2	-24.9

NOTES

Values are dB(A) (pressure level)

EWAD-D-XS

Unit size	Distance						
	1m	5m	10m	15m	20m	25m	50m
250	0.0	-8.0	-12.9	-16.0	-18.2	18.2	-25.8
280	0.0	-7.7	-12.5	-15.6	-17.8	17.8	-25.3
300	0.0	-7.7	-12.5	-15.6	-17.8	17.8	-25.3
330	0.0	-7.7	-12.5	-15.6	-17.8	17.8	-25.3
350	0.0	-7.7	-12.5	-15.6	-17.8	17.8	-25.3
380	0.0	-7.7	-12.5	-15.6	-17.8	17.8	-25.3
400	0.0	-7.7	-12.5	-15.6	-17.8	17.8	-25.3
470	0.0	-7.8	-12.6	-15.7	-17.9	17.9	-25.4
520	0.0	-7.5	-12.3	-15.3	-17.6	17.6	-25.0
580	0.0	-7.5	-12.3	-15.3	-17.6	17.6	-25.0
620	0.0	-7.5	-12.3	-15.3	-17.6	17.6	-25.0

NOTES

Values are dB(A) (pressure level)

EWAD-D-XR

Unit size	Distance						
	1m	5m	10m	15m	20m	25m	50m
240	0.0	-8.0	-12.9	-16.0	-18.2	-20.0	-25.8
270	0.0	-7.7	-12.5	-15.6	-17.8	-19.6	-25.3
300	0.0	-7.7	-12.5	-15.6	-17.8	-19.6	-25.3
320	0.0	-7.7	-12.5	-15.6	-17.8	-19.6	-25.3
350	0.0	-7.7	-12.5	-15.6	-17.8	-19.6	-25.3
370	0.0	-7.7	-12.5	-15.6	-17.8	-19.6	-25.3
390	0.0	-7.7	-12.5	-15.6	-17.8	-19.6	-25.3
460	0.0	-7.8	-12.6	-15.7	-17.9	-19.7	-25.4
510	0.0	-7.5	-12.3	-15.3	-17.6	-19.3	-25.0
560	0.0	-7.5	-12.3	-15.3	-17.6	-19.3	-25.0
600	0.0	-7.5	-12.3	-15.3	-17.6	-19.3	-25.0

NOTES

Values are dB(A) (pressure level)

7 Installation

7 - 1 Installation Method

7

Installation notes

Warning

Installation and maintenance of the unit must be performed only by qualified personnel who have knowledge with local codes and regulations, and experience with this type of equipment. The unit must be installed to allow all the maintenance operations.

Handling

Care should be taken to avoid rough handling or shock due to dropping of the unit. Do not push or pull the unit from anything other than the base frame. Never allow the unit to fall during unloading or moving as this may result in serious damage. To lift the unit, rings are provided in the base frame of the unit. Spreader bar and cables should be arranged to prevent damage to the condenser coil or unit cabinet.

Location

The units are produced for outside installation on roofs, floors or below ground level on condition that the area is free from obstacles for the passage of the condenser air. The unit should be positioned on solid foundations and perfectly level; in the case of installation on roofs or floors, it may be advisable to arrange the use of suitable weight distribution beams. When the units are installed on the ground, a concrete base at least 250 mm wider and longer than the unit's footprint should be laid. Furthermore, this base should withstand the unit weight mentioned in the technical data table.

Space requirements

The units are air-cooled, then it is important to respect the minimum distances which guarantee the best ventilation of the condenser coils. Limitations of space reducing the air flow could cause significant reductions in cooling capacity and an increase in electricity consumption.

To determinate unit placement, careful consideration must be given to assure a sufficient air flow across the condenser heat transfer surface. Two conditions must be avoided to achieve the best performance: warm air recirculation and coil starvation. Both these conditions cause an increase of condensing pressures that result in reductions in unit efficiency and capacity.

Moreover the unique microprocessor has the ability to analyse the operating environment of the air cooled chiller and to optimize its performance to stay on-line during abnormal conditions.

Each side of the unit must be accessible after installation for periodic service. Fig.1 shows you minimum recommended clearance requirements.

Vertical condenser air discharge must be unobstructed because the unit would have its capacity and efficiency significantly reduced.

If the units are positioned in places surrounded by walls or obstacles of the same height as the units, the units should be at least 2500 mm from obstacles (Fig.2). In the event the obstacles are higher than the units, the units should be at least 3000 mm from the obstacle (Fig.3). Units installed closer than the minimum recommended distance to a wall or other vertical riser may experience a combination of coil starvation and warm air recirculation, thus causing reduction in unit capacity and efficiency reductions. The microprocessor control is proactive in response "of design condition". In the case of single or compounded influences restricting airflow to the unit, the microprocessor will act to keep the compressor running (at reduced capacity) rather than allowing a shut-off on high discharge pressure.

When two or more units are positioned side by side it is recommended that the condenser coils are at least 3600 mm distance from one another (Fig.4); strong wind could be the cause of air warm recirculation.

For other installation solutions, consult our technicians.

7 Installation

7 - 1 Installation Method

The above recommended information are representative for general installation. A specific evaluation should be done by contractor depending on the case.

Minimum recommended installation clearances

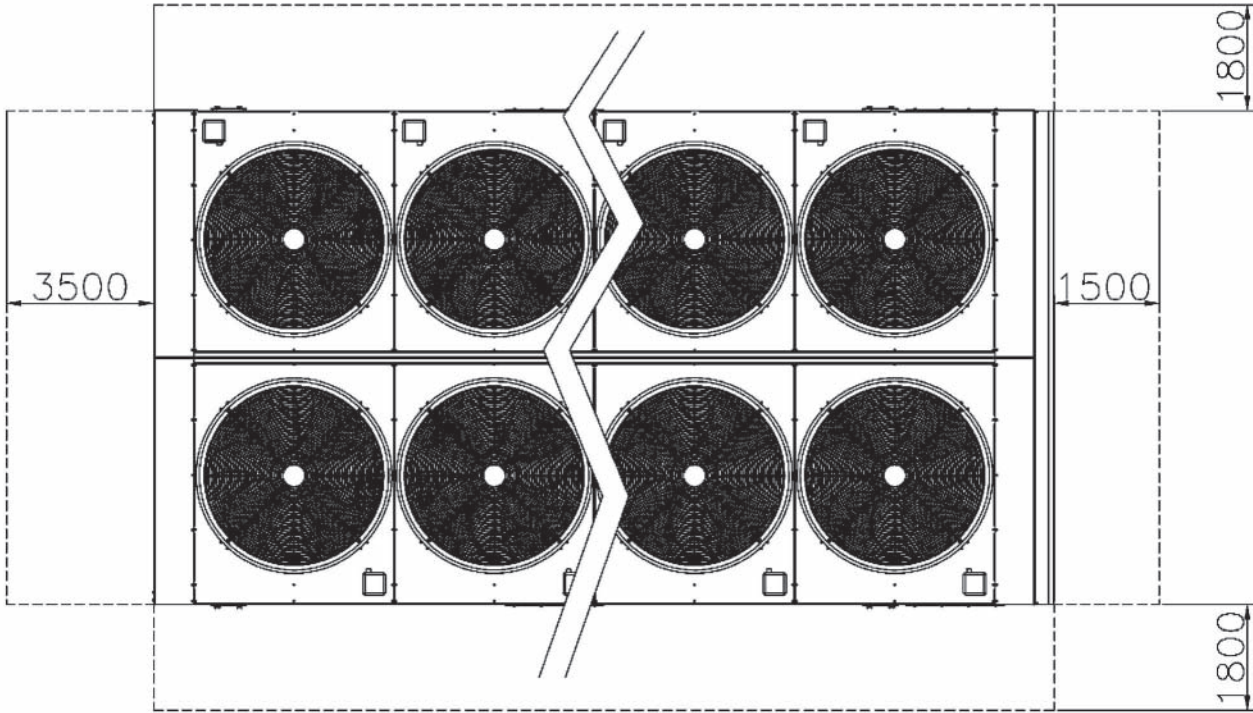

Fig. 1

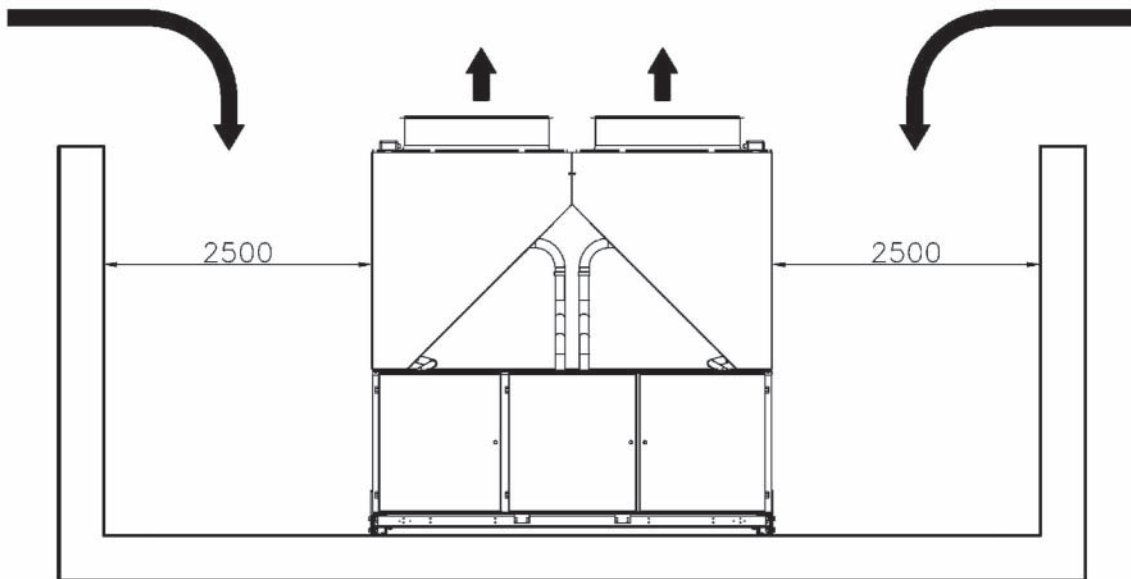

Fig. 2

7 Installation

7 - 1 Installation Method

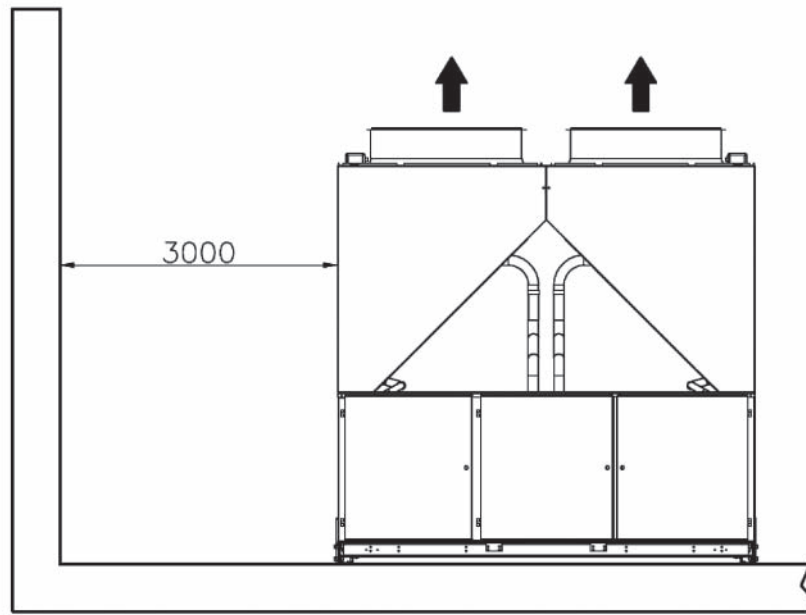

Fig. 3

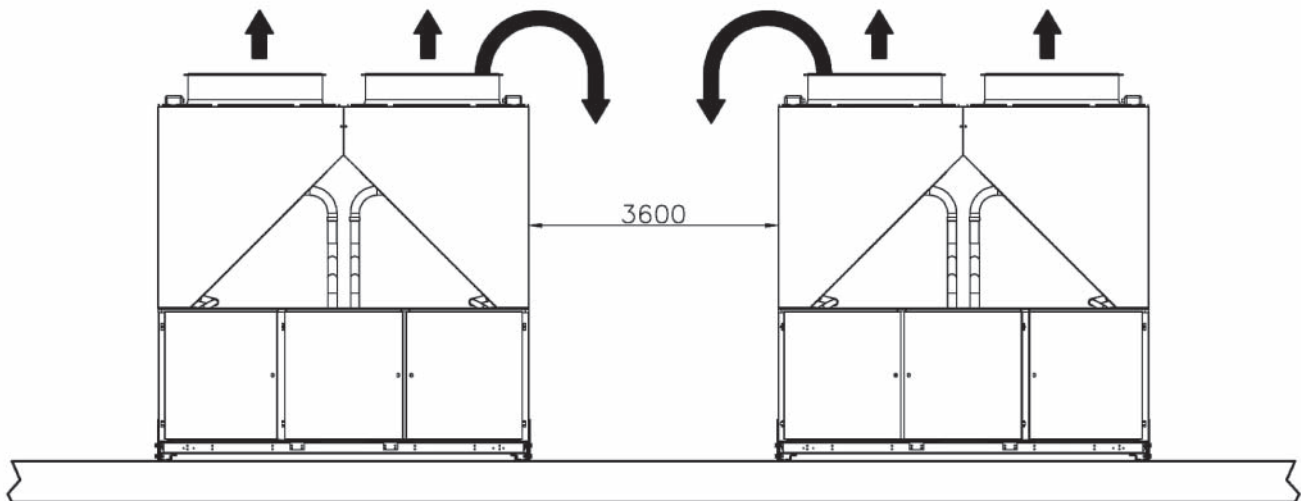

Fig. 4

Acoustic protection

When noise level must meet special requirements, it is necessary to pay the maximum attention to ensure the perfect insulation of the unit from the support base by applying appropriate vibration-dampening devices on the unit, on the water pipes and on the electrical connections.

Storage

The environment conditions have to be in the following limits:

Minimum ambient temperature:	-20°C
Maximum ambient temperature:	+57°C
Maximum R.H.:	95% not condensing

8 Operation range

8 - 1 Operation Range

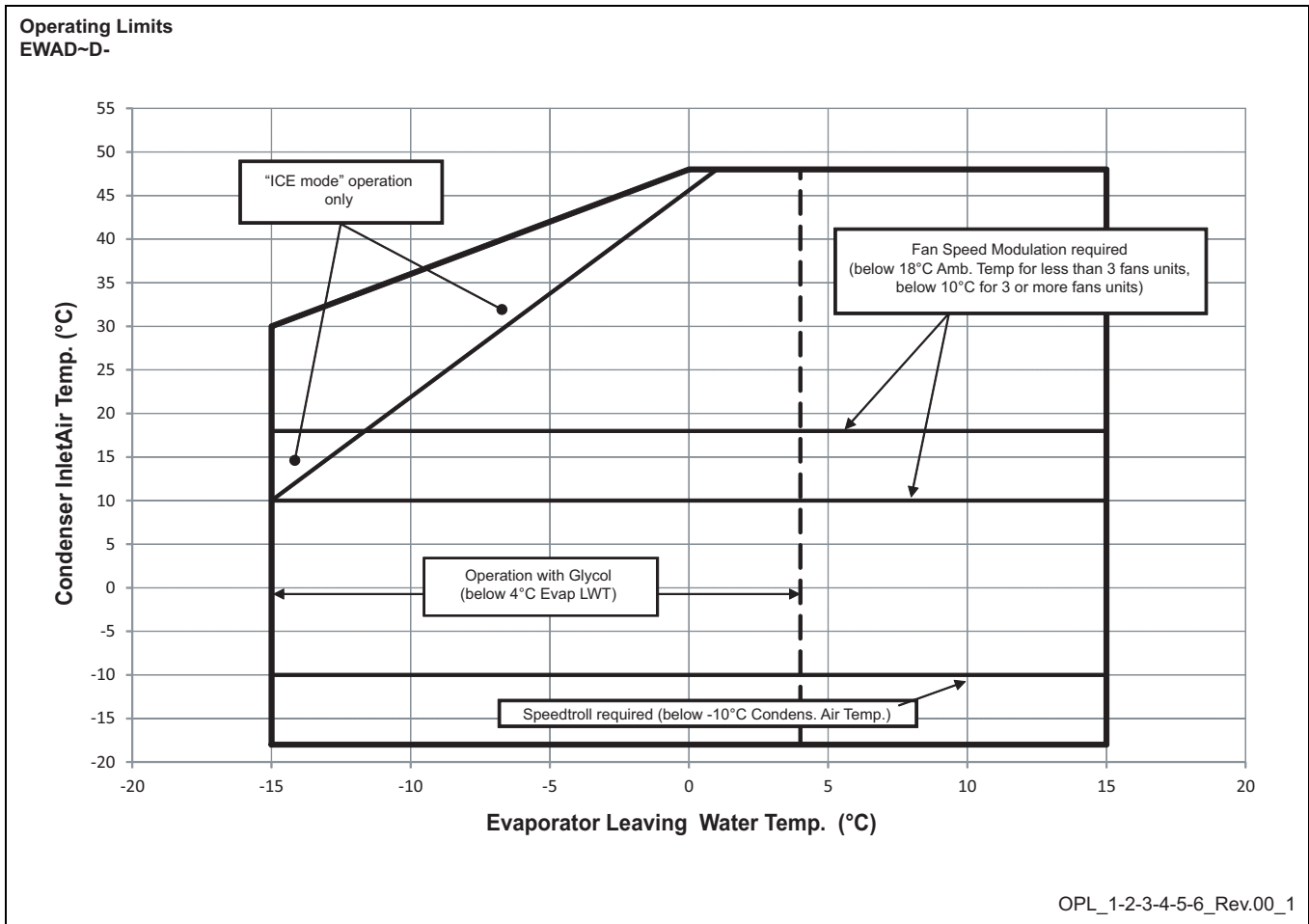

8 Operation range

8 - 1 Operation Range

8

Table 1 - Evaporator minimum and maximum water Δt

Max evaporator water Δt	°C	8
Min evaporator water Δt	°C	4

Table 2 - Evaporator fouling factors

Fouling factors m ² °C / kW	Cooling capacity correction factor	Power input correction factor	EER correction factor
0.0176	1.000	1.000	1.000
0.0440	0.978	0.986	0.992
0.0880	0.957	0.974	0.983
0.1320	0.938	0.962	0.975

Table 3 - Air heat exchanger - Altitude correction factors

Elevation above sea level (m)	0	300	600	900	1200	1500	1800
Barometric pressure (mbar)	1013	977	942	908	875	843	812
Cooling capacity correction factor	1.000	0.993	0.986	0.979	0.973	0.967	0.960
Power input correction factor	1.000	1.005	1.009	1.015	1.021	1.026	1.031

- Maximum operating altitude is 2000 m above sea level.

- Contact factory in case the unit has to be installed at altitudes between 1000 and 2000 m above sea level.

Table 4.1 - Minimum glycol percentage for low water temperature

EWLT (°C)	2	0	-2	-4	-6	-8	-10	-12	-15
Ethylene glycol (%)	10	20	20	20	30	30	30	40	40
Propylene glycol (%)	10	20	20	30	30	30	40	40	40

- ELWT (Evaporator Leaving Water Temperature (°C)).

- Minimum glycol percentage to be used with evaporator leaving water temperature below 4°C to prevent freezing of water circuit.

Table 4.2 - Minimum glycol percentage for low air ambient temperature

Air Ambient Temperature (°C) (2)	-3	-8	-15	-20
Ethylene glycol (%) (1)	10%	20%	30%	40%
Air Ambient Temperature (°C) (2)	-3	-7	-12	-20
Propylene glycol (%) (1)	10%	20%	30%	40%

- Minimum glycol percentage to prevent freezing of water circuit at indicated air ambient temperature.

- Air ambient temperature do exceed the operating limits of the unit, as protection of water circuit may be needed in winter season at non-working conditions.

Table 5 - Correction factors for low evaporator leaving water temperature (EWLT < 4°C)

EWLT (°C)	-4	-6	-8	-10	-12	-15
Cooling Capacity	0.670	0.613	0.562	0.510	0.455	0.375
Compressor Power Input	0.890	0.870	0.840	0.798	0.755	0.680

- ELWT (Evaporator Leaving Water Temperature (°C)).

- Correction factors have to be applied at working conditions: evaporator leaving water temperature 7°C.

Table 6 - Correction factors for water and glycol mixture

	Ethylene Glycol (%)	10%	20%	30%	40%	50%
Ethylene Glycol	Cooling Capacity	0.991	0.982	0.972	0.961	0.946
	Compressor Power Input	0.996	0.992	0.986	0.976	0.966
	Flow Rate (Δt)	1.013	1.04	1.074	1.121	1.178
	Evaporator Pressure Drop	1.070	1.129	1.181	1.263	1.308
Propylene Glycol	Cooling Capacity	0.985	0.964	0.932	0.889	0.846
	Compressor Power Input	0.993	0.983	0.969	0.948	0.929
	Flow Rate (Δt)	1.017	1.032	1.056	1.092	1.139
	Evaporator Pressure Drop	1.120	1.272	1.496	1.792	2.128

- Contact factory for water temperature out of operating limits.

8 Operation range

8 - 1 Operation Range

How to use the Correction factors proposed in the previous tables

A) Mixture Water and Glycol --- Evaporator leaving water temperature > 4°C

- depending from the type and percentage (%) of glycol filled in the circuit (see table 4.2 and 6)
- multiply the Cooling Capacity, the Compressor Power Input by the Correction factor of Table 6
- starting from this new value of Cooling Capacity, calculate the Flow Rate (l/s) and the Evaporator Pressure Drop (kPa)
- now multiply the new Flow Rate and the new Evaporator Pressure Drop by the Correction Factors of Table 6

Example

Unit Size: **EWAD390D-SS**

Mixture: Water
 Working condition: ELWT 12/7°C – Condenser inlet air temperature 35°C
 - Cooling capacity: 389 kW
 - Power input: 152 kW
 - Flow rate (Δt 5°C): 18.60 l/s
 - Evaporator pressure drop: 46 kPa

Mixture: Water + Ethylene Glycol 30% (for a winter air temperature up to -15°C)
 Working condition: ELWT 12/7°C – Condenser inlet air temperature 35°C
 - Cooling capacity: $389 \times 0.972 = 378$ kW
 - Power input: $152 \times 0.986 = 150$ kW
 - Flow rate (Δt 5°C): 18 (referred to 378 kW) $\times 1.074 = 19.33$ l/s
 - Evaporator pressure drop: 49 (referred to 19.33 l/s) $\times 1.181 = 58$ kPa

B) Mixture Water and Glycol --- Evaporator leaving water temperature < 4°C

- depending from the type and percentage (%) of glycol filled in the circuit (see table 4.1 and 4.2 and table 6)
- depending from the evaporator leaving water temperature (see table 5)
- multiply the Cooling Capacity, the Compressor Power Input by the Correction factor of Table 5 and Table 6
- starting from this new value of Cooling Capacity, calculate the Flow Rate (l/s) and the Evaporator Pressure Drop (kPa)
- now multiply the new Flow Rate and the new Evaporator Pressure Drop by the Correction Factors of Table 6

Example

Unit Size: **EWAD390D-SS**

Mixture: Water
 Standard working condition: ELWT 12/7°C – Condenser inlet air temperature 30°C
 - Cooling capacity: 412 kW
 - Power input: 139 kW
 - Flow rate (Δt 5°C): 19.7 l/s
 - Evaporator pressure drop: 51 kPa

Mixture: Water + Glycol 30% (for a low evaporator leaving temperature of -1/-6°C)
 Working condition: ELWT -1/-6°C – Condenser inlet air temperature 30°C
 - Cooling capacity: $412 \times 0.613 \times 0.972 = 245$ kW
 - Power input: $139 \times 0.870 \times 0.986 = 119$ kW
 - Flow rate (Δt 5°C): 11.71 l/s (referred to 245 kW) $\times 1.074 = 12.58$ l/s
 - Evaporator pressure drop: 23 kPa (referred to 12.58 l/s) $\times 1.181 = 27$ kPa

8 Operation range

8 - 1 Operation Range

8

Table 7.1 - Available fan static pressure correction factors

"External Static Pressure (Pa)"	0	10	20	30	40	50	60	70	80	90	100
"Cooling Capacity (kW) Correction factor"	1.000	0.998	0.996	0.995	0.993	0.992	0.991	0.989	0.986	0.985	0.982
"Compr. Power Input (kW) Correction factor"	1.000	1.004	1.009	1.012	1.018	1.021	1.024	1.027	1.034	1.039	1.045
Reduction of Max CIAT (°C)	1.000	-0.3	-0.5	-0.7	-1.0	-1.1	-1.3	-1.6	-1.8	2.1	-2.4

CIAT: Condenser Inlet Air Temperature

ESP table refers to fan diameter Ø800, available on units as follows:

EWAD390~580D-SS
EWAD470~620D-XS
EWAD420~590D-HS

Table 7.2 - Available fan static pressure correction factors

"External Static Pressure (Pa)"	0	10	20	30	40	50	60	70
"Cooling Capacity (kW) Correction factor"	1.000	0.996	0.991	0.985	0.978	0.97	0.954	0.927
"Compr. Power Input (kW) Correction factor"	1.000	1.005	1.012	1.02	1.028	1.039	1.058	1.092
Reduction of Max CIAT (°C)	1.000	-0.3	-0.7	-1.1	-1.6	-2.2	-3.3	-5.1

CIAT: Condenser Inlet Air Temperature

ESP table refers to fan diameter Ø800, available on units as follows:

EWAD320~530D-SL/SR
EWAD460~600D-XR

How to use the Correction factors proposed in the previous tables

Example

Unit Size: **EWAD390D-SS**

- External static pressure **0 Pa**
- Working condition: ELWT 12/7°C – Condenser inlet air temperature 35°C
- Cooling capacity: 389 kW
- Power input: 152 kW
- Maximum CIAT 48°C (see graphic operating limit)

- External static pressure **40 Pa**
- Working condition: ELWT 12/7°C – Condenser inlet air temperature 35°C
- Cooling capacity: 389 x 0.993 = 386 kW
- Power input: 152 x 1.018 = 155 kW
- Maximum CIAT 48 - 1.0 = 47°C

8 Operation range

8 - 1 Operation Range

Water charge, flow and quality

Items ⁽¹⁾⁽⁵⁾	Cooling Water			Cooled Water		Heated water ⁽²⁾				Tendency if out of criteria			
	Circulating System		Once Flow	Cooled Water		Low temperature		High temperature					
	Circulating water	Supply water ⁽⁴⁾	Flowing water	Circulating water [Below 20°C]	Supply water ⁽⁴⁾	Circulating water [20°C ~ 60°C]	Supply water ⁽⁴⁾	Circulating water [60°C ~ 80°C]	Supply water ⁽⁴⁾				
Items to be controlled:	pH	at 25°C	6.5 ~ 8.2	6.0 ~ 8.0	6.0 ~ 8.0	6.0 ~ 8.0	6.0 ~ 8.0	7.0 ~ 8.0	7.0 ~ 8.0	7.0 ~ 8.0	7.0 ~ 8.0	Corrosion + Scale	
	Electrical conductivity	[mS/m] at 25°C	Below 80	Below 30	Below 40	Below 40	Below 30	Below 30	Below 30	Below 30	Below 30	Below 30	Corrosion + Scale
		(μS/cm) at 25°C	(Below 800)	(Below 300)	(Below 400)	(Below 400)	(Below 300)	(Below 300)	(Below 300)	(Below 300)	(Below 300)	(Below 300)	Corrosion + Scale
	Chloride ion	[mgCl ⁻ /l]	Below 200	Below 50	Below 50	Below 50	Below 50	Below 50	Below 50	Below 50	Below 30	Below 30	Corrosion
	Sulfate ion	[mgSO ₄ ²⁻ /l]	Below 200	Below 50	Below 50	Below 50	Below 50	Below 50	Below 50	Below 50	Below 30	Below 30	Corrosion
	M-alkalinity (pH4.8)	[mgCaCO ₃ /l]	Below 100	Below 50	Below 50	Below 50	Below 50	Below 50	Below 50	Below 50	Below 50	Below 50	Scale
	Total hardness	[mgCaCO ₃ /l]	Below 200	Below 70	Below 70	Below 70	Below 70	Below 70	Below 70	Below 70	Below 70	Below 70	Scale
	Calcium hardness	[mgCaCO ₃ /l]	Below 150	Below 50	Below 50	Below 50	Below 50	Below 50	Below 50	Below 50	Below 50	Below 50	Scale
Silica ion	[mgSiO ₂ /l]	Below 50	Below 30	Below 30	Below 30	Below 30	Below 30	Below 30	Below 30	Below 30	Below 30	Scale	
Items to be referred to	Iron	[mgFe/l]	Below 1.0	Below 0.3	Below 1.0	Below 1.0	Below 0.3	Below 1.0	Below 0.3	Below 1.0	Below 0.3	Below 0.3	Corrosion + Scale
	Copper	[mgCu/l]	Below 0.3	Below 0.1	Below 1.0	Below 1.0	Below 1.0	Below 1.0	Below 0.1	Below 1.0	Below 0.1	Below 0.1	Corrosion
	Sulfite ion	[mgS ²⁻ /l]	Not detectable	Not detectable	Not detectable	Not detectable	Not detectable	Not detectable	Not detectable	Not detectable	Not detectable	Not detectable	Corrosion
	Ammonium ion	[mgNH ₄ ⁺ /l]	Below 1.0	Below 0.1	Below 1.0	Below 1.0	Below 0.1	Below 0.3	Below 0.1	Below 0.1	Below 0.1	Below 0.1	Corrosion
	Remaining chloride	[mgCL/l]	Below 0.3	Below 0.3	Below 0.3	Below 0.3	Below 0.3	Below 0.25	Below 0.3	Below 0.3	Below 0.1	Below 0.3	Corrosion
	Free carbide	[mgCO ₂ /l]	Below 4.0	Below 4.0	Below 4.0	Below 4.0	Below 4.0	Below 0.4	Below 4.0	Below 0.4	Below 4.0	Below 4.0	Corrosion
	Stability index		6.0 ~ 7.0	---	---	---	---	---	---	---	---	---	Corrosion + Scale

NOTES

- Names, definitions and units are according to JIS K 0101. Units and figures between brackets are old units published as reference only.
- In case of using heated water (more than 40°C), corrosion is generally noticeable. Especially when the iron materials is in direct contact with water without any protection shields, it is desirable to give the valid measure for corrosion. E.g. chemical measure.
- In the cooling water using hermetic cooling tower, close circuit water is according to heated water standard, and scattered water is according to cooling water standard.
- Supply water is considered drink water, industrial water and ground water except for genuine water, neutral water and soft water.
- The above mentioned items are representable items in corrosion and scale cases.

OPL_1-2-3-4-5-6_Rev.00_5

8 Operation range

8 - 1 Operation Range

8

Water content in cooling circuits

The cooled water distribution circuits should have minimum water content to avoid excessive compressors start and stop. In fact, each time the compressor starts up, an excessive quantity of oil goes from the compressor sump and simultaneously there is a rise in the temperature of the compressor motor's stator due to the inrush current during the start-up. To prevent damage to the compressors, it has been envisaged the application of a device to limit frequent stops and restarts.

During the span of one hour there will be no more than 6 starts of the compressor. The plant side should therefore ensure that the overall water content allows a more constant functioning of the unit and consequently greater environmental comfort. The minimum water content per unit should be calculated using this simplified formula:

For 2 compressors unit

$$M \text{ (liters)} = (0.1595 \times \Delta T(^{\circ}\text{C}) + 3.0825) \times P(\text{kW})$$

where:

M minimum water content per unit expressed in litres

P Cooling Capacity of the unit expressed in kW

ΔT evaporator entering / leaving water temperature difference expressed in $^{\circ}\text{C}$

This formula is valid for:

- standard microprocessor parameters

For more accurate determination of quantity of water, it is advisable to contact the designer of the plant.

9 Hydraulic performance

9 - 1 Pump Characteristics

Water Pump Kit - Available External Static Pressure

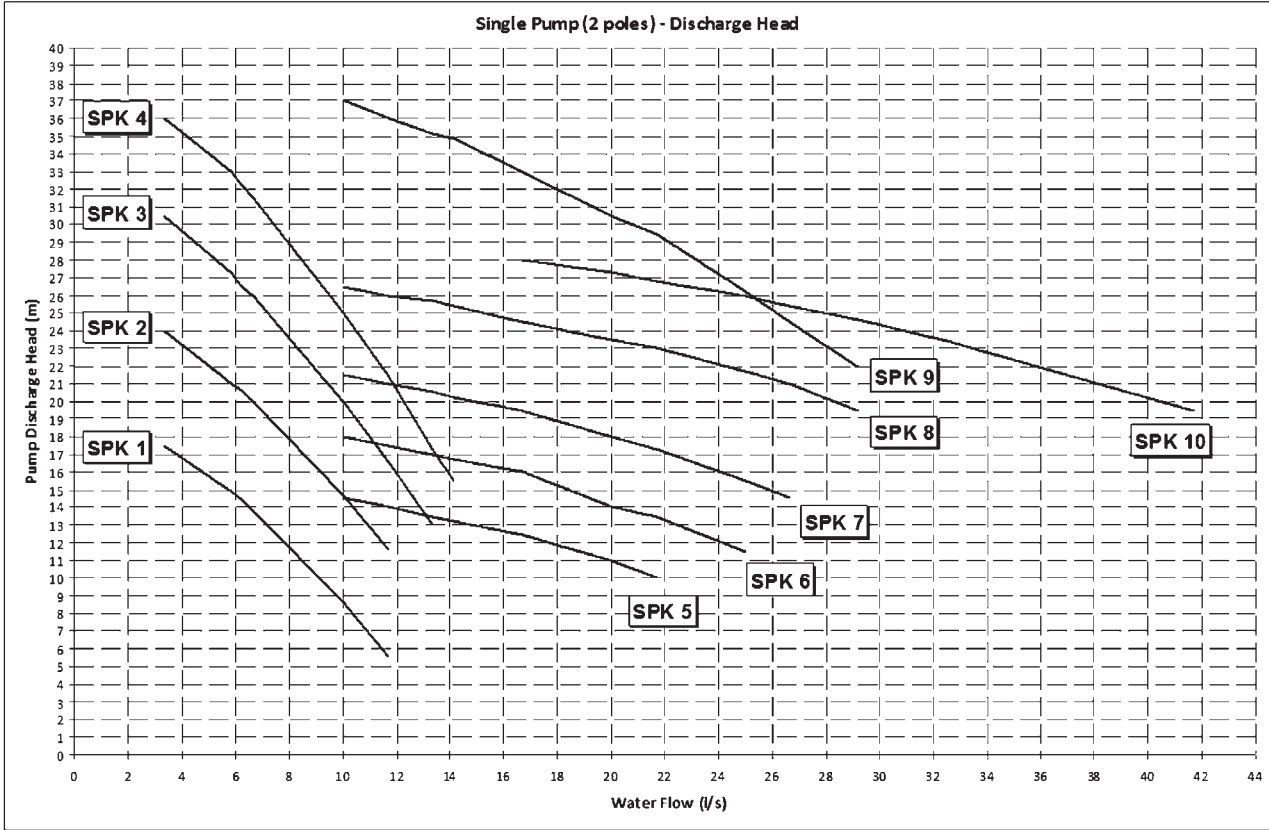

OPT_1-2-3-4-5a-6-7-8_Rev.01_6 (1/2)

Water Pump Kit - Available External Static Pressure

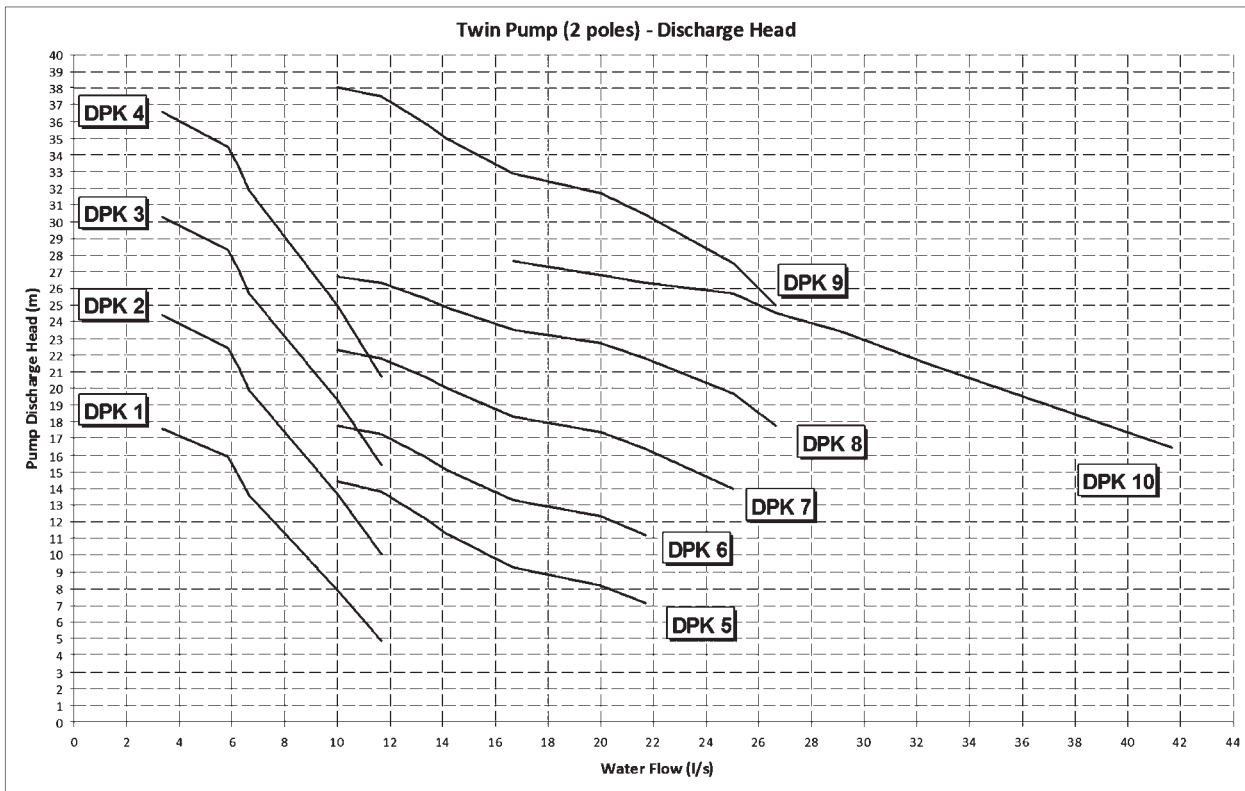

OPT_1-2-3-4-5a-6-7-8_Rev.01_6 (2/2)

9 Hydraulic performance

9 - 1 Pump Characteristics

9

Water Pump Kit - Technical Information

		Pump Motor Power (kW)	Pump Motor Current (A)	Power supply (V-ph-Hz)	PN	Motor Protection	Insulation (Class)	Working Temp. (°C)
Single Pump	SPK 1	1.5	3.5	400V-3ph-50hz	PN10	IP55	F	-10 ~ 130
	SPK 2	2.2	5.0	400V-3ph-50hz	PN10	IP55	F	-10 ~ 130
	SPK 3	3.0	6.0	400V-3ph-50hz	PN10	IP55	F	-10 ~ 130
	SPK 4	4.0	8.1	400V-3ph-50hz	PN10	IP55	F	-10 ~ 130
	SPK 5	3.0	6.0	400V-3ph-50hz	PN10	IP55	F	-10 ~ 130
	SPK 6	4.0	8.1	400V-3ph-50hz	PN10	IP55	F	-10 ~ 130
	SPK 7	5.5	10.1	400V-3ph-50hz	PN10	IP55	F	-10 ~ 130
	SPK 8	7.5	13.7	400V-3ph-50hz	PN10	IP55	F	-10 ~ 130
	SPK 9	11.0	20.0	400V-3ph-50hz	PN10	IP55	F	-10 ~ 130
	SPK 10	11.0	20.0	400V-3ph-50hz	PN10	IP55	F	-10 ~ 130
Double Pump	DPK 1	1.5	3.5	400V-3ph-50hz	PN10	IP55	F	-10 ~ 130
	DPK 2	2.2	5.0	400V-3ph-50hz	PN10	IP55	F	-10 ~ 130
	DPK 3	3.0	6.0	400V-3ph-50hz	PN10	IP55	F	-10 ~ 130
	DPK 4	4.0	8.1	400V-3ph-50hz	PN10	IP55	F	-10 ~ 130
	DPK 5	3.0	6.0	400V-3ph-50hz	PN10	IP55	F	-10 ~ 130
	DPK 6	4.0	8.1	400V-3ph-50hz	PN10	IP55	F	-10 ~ 130
	DPK 7	5.5	10.1	400V-3ph-50hz	PN10	IP55	F	-10 ~ 130
	DPK 8	7.5	13.7	400V-3ph-50hz	PN10	IP55	F	-10 ~ 130
	DPK 9	11.0	20.0	400V-3ph-50hz	PN10	IP55	F	-10 ~ 130
	DPK 10	11.0	20.0	400V-3ph-50hz	PN10	IP55	F	-10 ~ 130

NOTES

- when using mixture of water and glycol please contact the factory as above specification can change

OPT_1-2-3-4-5a-6-7-8_Rev.01_7

9 Hydraulic performance

9 - 1 Pump Characteristics

Water Pump Kit - Combination Matrix

Version	Size	Single Pump									
		SPK 1	SPK 2	SPK 3	SPK 4	SPK 5	SPK 6	SPK 7	SPK 8	SPK 9	SPK 10
EWAD-D-SS	390						X	X	X	X	X
	440						X	X	X	X	X
	470						X	X	X	X	X
	510						X	X	X	X	X
	530						X	X	X	X	X
	560						X	X	X	X	X
	580						X	X	X	X	X
	580						X	X	X	X	X
EWAD-D-SL	180	X	X	X	X						
	200	X	X	X	X						
	230		X	X	X						
	250		X	X	X		X	X	X	X	
	260			X	X		X	X	X	X	
	280			X	X		X	X	X	X	
	300			X	X		X	X	X	X	
	320					X	X	X	X	X	
	370					X	X	X	X	X	
	400					X	X	X	X	X	X
	440						X	X	X	X	X
	480						X	X	X	X	X
	510						X	X	X	X	X
	530						X	X	X	X	X
	EWAD-D-SR	180	X	X	X	X					
190		X	X	X	X						
220			X	X	X		X	X	X	X	
240			X	X	X		X	X	X	X	
250			X	X	X		X	X	X	X	
270				X	X		X	X	X	X	
280				X	X		X	X	X	X	
310						X	X	X	X	X	
370						X	X	X	X	X	X
400						X	X	X	X	X	X
440							X	X	X	X	X
480							X	X	X	X	X
510							X	X	X	X	X
530							X	X	X	X	X
EWAD-D-SX		210		X	X	X					
	230		X	X	X	X	X	X	X	X	
	250			X	X	X	X	X	X	X	
	270			X	X	X	X	X	X	X	
	290				X	X	X	X	X	X	
	300				X	X	X	X	X	X	
	310				X	X	X	X	X	X	
	370				X	X	X	X	X	X	X
	410				X	X	X	X	X	X	X
	450				X	X	X	X	X	X	X
	490				X	X	X	X	X	X	X
	250			X	X	X	X	X	X	X	
	280			X	X	X	X	X	X	X	
	300				X	X	X	X	X	X	
	330				X	X	X	X	X	X	
350				X	X	X	X	X	X	X	
380				X	X	X	X	X	X	X	
400				X	X	X	X	X	X	X	
470					X	X	X	X	X	X	
520					X	X	X	X	X	X	
580							X	X	X	X	
620								X	X	X	
EWAD-D-XS	240		X	X	X	X	X	X	X	X	
	270			X	X	X	X	X	X	X	
	300			X	X	X	X	X	X	X	
	320			X	X	X	X	X	X	X	
	350			X	X	X	X	X	X	X	
	370			X	X	X	X	X	X	X	
	390				X	X	X	X	X	X	X
	460					X	X	X	X	X	X
	510					X	X	X	X	X	X
	560							X	X	X	X
EWAD-D-XR	240		X	X	X	X	X	X	X	X	
	270			X	X	X	X	X	X	X	
	300			X	X	X	X	X	X	X	
	320			X	X	X	X	X	X	X	
	350			X	X	X	X	X	X	X	
	370			X	X	X	X	X	X	X	
	390				X	X	X	X	X	X	X
	460					X	X	X	X	X	X
	510					X	X	X	X	X	X
	560							X	X	X	X
	600								X	X	X
	EWAD-D-HS	200		X	X	X					
210			X	X	X						
230			X	X	X	X	X	X	X	X	
260				X	X	X	X	X	X	X	
270				X	X	X	X	X	X	X	
290					X	X	X	X	X	X	
310					X	X	X	X	X	X	
340					X	X	X	X	X	X	
380					X	X	X	X	X	X	X
420					X	X	X	X	X	X	X
450						X	X	X	X	X	X
480						X	X	X	X	X	X
510						X	X	X	X	X	X
550							X	X	X	X	X
590								X	X	X	X

9 Hydraulic performance

9 - 1 Pump Characteristics

9

Water Pump Kit - Combination Matrix

Version	Size	Double Pump										
		DPK 1	DPK 2	DPK 3	DPK 4	DPK 5	DPK 6	DPK 7	DPK 8	DPK 9	DPK 10	
EWAD-D-SS	390						X	X	X	X	X	
	440						X	X	X	X	X	
	470							X	X	X	X	
	510							X	X	X	X	
	530								X	X	X	
	560								X	X	X	
	580									X	X	
	180	X	X	X	X							
	200	X	X	X	X							
	230		X	X	X							
EWAD-D-SL	250		X	X				X		X		
	260							X		X		
	280					X	X	X		X		
	300					X	X	X		X		
	320						X	X		X		
	370						X	X		X	X	
	400						X	X		X	X	
	440						X	X		X	X	
	480							X	X	X	X	
	510							X	X	X	X	
	530								X	X	X	
	EWAD-D-SR	180	X	X	X	X						
		190	X	X	X	X						
220			X	X	X					X		
240				X	X		X	X		X		
250			X	X	X		X	X		X		
270							X	X		X		
280							X	X		X		
310							X	X		X		
370							X	X		X	X	
400							X	X		X	X	
440							X	X		X	X	
480							X	X		X	X	
510							X	X		X	X	
EWAD-D-SX	210		X	X	X							
	230		X	X	X	X	X	X	X			
	250			X	X	X	X	X	X			
	270			X	X	X	X	X	X			
	290				X	X	X	X	X			
	300				X	X	X	X	X			
	310				X	X	X	X	X			
	370				X	X	X	X	X		X	
	410				X	X	X	X	X		X	
	450				X	X	X	X	X		X	
EWAD-D-XS	250					X	X	X	X			
	280				X	X	X	X	X			
	300				X	X	X	X	X			
	330				X	X	X	X	X			
	350					X	X	X	X		X	
	380					X	X	X	X		X	
	400					X	X	X	X		X	
	470						X	X	X		X	
	520						X	X	X		X	
	580										X	
EWAD-D-XR	240		X	X	X		X	X	X			
	270				X	X	X	X	X			
	300				X	X	X	X	X			
	320				X	X	X	X	X			
	350					X	X	X	X			
	370					X	X	X	X		X	
	390					X	X	X	X		X	
	460						X	X	X		X	
	510						X	X	X		X	
	560										X	
EWAD-D-HS	200	X	X	X	X							
	210	X	X	X	X							
	230		X	X	X					X		
	260						X	X	X	X		
	270						X	X	X	X		
	290					X	X	X	X	X		
	310					X	X	X	X	X		
	340						X	X	X	X		
	360						X	X	X	X	X	
	420						X	X	X	X	X	
	450						X	X	X	X	X	
	480							X	X	X	X	
	510							X	X	X	X	
550								X	X	X		
590									X	X		

9 Hydraulic performance

9 - 2 Total Heat Recovery Pressure Drop

Total and Partial Heat Recovery Pressure Drops

To determinate the pressure drop for different versions or at different working condition, please refer to the following formula:

$$PD_2 \text{ (kPa)} = PD_1 \text{ (kPa)} \times \left(\frac{Q_2 \text{ (l/s)}}{Q_1 \text{ (l/s)}} \right)^{1.80}$$

where:

- PD_2 Pressure drop to be determinate (kPa)
- PD_1 Pressure drop at nominal condition (kPa)
- Q_2 water flow at new working condition (l/s)
- Q_1 water flow at nominal condition (l/s)

How to use the formula: Example

The unit EWAD390D-SS has been selected for working at the following conditions:

- Total heat recovery leaving water temperature 40/50°C
- The heating capacity at these working conditions is: 415 kW
- The water flow at these working conditions is: 9.91 l/s

The unit EWAD390D-SS at nominal working conditions has the following data:

- Total heat recovery leaving water temperature 40/45°C
- condenser air inlet: 35°C
- The heating capacity at these working conditions is: 427 kW
- The water flow at these working conditions is: 20.41 l/s
- The pressure drop at these working conditions is: 37 kPa

The pressure drop at the selected working condition will be:

$$PD_2 \text{ (kPa)} = 37 \text{ (kPa)} \times \left(\frac{9.91 \text{ (l/s)}}{20.41 \text{ (l/s)}} \right)^{1.80}$$

$$PD_2 \text{ (kPa)} = 10 \text{ (kPa)}$$

OPT_1-2-3-4-5a-6-7-8_Rev.01_5

10 Specification text

10 - 1 Specification Text

10

Features and advantages

Low operating cost

This chiller range is the result of careful design, aimed to optimize the energy efficiency of the chillers, with the objective of bringing down operating costs and improving installation profitability, effectiveness and economical management.

The chillers feature a high efficiency single rotor screw compressor design, large condenser coil surface area for maximum heat transfer and low discharge pressure, advanced technology condenser fans and a 'plate to plate' or 'shell&tube' evaporator with low refrigerant pressure drops.

Low operating sound levels

Very low sound levels both at full load and part load conditions are achieved by the latest compressor design and by a unique new fan that moves large volume of air at exceptionally low sound levels and by the virtually vibration-free operation.

Excellent serviceability

Field serviceability has not been sacrificed to meet design performance objectives. The compressor is equipped with discharge, liquid and suction shut off valves. The compressor and serviceable components such as filter-driers are located on the outside edges of the base allowing, together with the shape of the coil, an easy access for inspection and service. Moreover, the MicroTech III controller gives detailed information on the causes of an alarm or fault.

Proven reliability

Full factory testing of every unit with water hook-up helps in providing a trouble-free start-up. Extensive quality control checks during testing means that each equipment protection and operating control is properly adjusted and operates correctly before it leaves the factory.

Infinite capacity control

Cooling capacity control is infinitely variable by means of a single screw compressor controlled by microprocessor system. Each unit has infinitely variable capacity control from 100% down to 12.5%. This modulation allows the compressor capacity to exactly match the building cooling load. Chilled water temperature fluctuation is avoided only with a stepless control.

In the case that the compressor with load step control is used, the compressor capacity, at partial loads, will be too high or too low compared to the building cooling load. The result is an increase in chiller energy costs, particularly at the part-load conditions at which the chiller operates most of the time.

Units with stepless regulation offer benefits that the units with step regulation are unable to match.

Only a chiller with step-less regulation, is able to follow the system cooling demand at any time and to deliver chilled water at set-point.

Superior control logic

The new MicroTech III controller provides an easy to use control environment. The control logic is designed to provide maximum efficiency and a history of unit operation. One of the greatest benefits is the easy interface with LonWorks, Bacnet, Ethernet TCP/IP or Modbus communications.

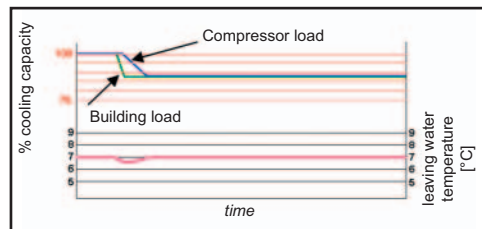

ELWT fluctuation with stepless capacity control

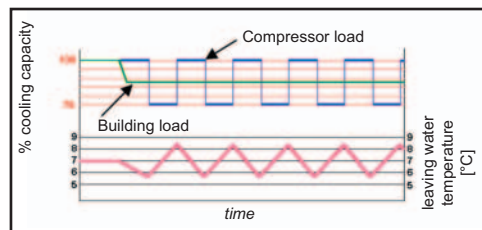

ELWT fluctuation with steps capacity control (4 steps)

10 Specification text

10 - 1 Specification Text

Code requirements – Safety and observant of laws/directives

The range is designed and manufactured in accordance with applicable selections of the following:

Construction of pressure vessel	97/23/EC (PED)
Machinery Directive	2006/42/EC
Low Voltage	2006/95/EC
Electromagnetic Compatibility	2004/108/EC
Electrical & Safety codes	EN 60204–1 / EN 60335-2-40
Manufacturing Quality Stds	UNI – EN ISO 9001:2004

Certifications

All units manufactured by Daikin are CE marked, complying with European directives in force, concerning manufacturing and safety. On request units can be produced complying with laws in force in non-European countries (ASME, GOST, etc.), and for other applications, such as naval (RINA, etc.).

Efficiency and sound configuration

The range is available in multiple efficiency and sound versions:

Efficiency level	Sound level			
	Standard	Low	Reduced	Extra low
Standard efficiency	EWAD~D-SS	EWAD~D-SL	EWAD~D-SR	EWAD~D-SX
High efficiency	EWAD~D-XS	N.A.	EWAD~D-XR	N.A.
High ambient	EWAD~D-HS	N.A.	N.A.	N.A.

Versions

The range is available in three versions:

S: Standard efficiency

7 sizes to cover a range from 389 up to 578 kW with an EER up to 2.03 and an ESEER up to 3.56 (data refers to Standard sound configuration)

X: High efficiency

11 sizes to cover a range from 247 up to 622 kW with an EER up to 3.20 and an ESEER up to 4.01 (data refers to Standard sound configuration)

H: High ambient temperature

15 sizes to cover a range from 195 up to 587 kW with an EER up to 3.07 and an ESEER up to 3.79 (data refers to Standard sound configuration)

The EER (Energy Efficiency Ratio) is the ratio of the Cooling Capacity to the Power Input of the unit. The Power Input includes: the power input for operation of the compressor, the power input of all control and safety devices, the power input for fans.

The ESEER (European Seasonal Energy Efficiency Ratio) is a weighted formula enabling to take into account the variation of EER with the load rate and the variation of air inlet condenser temperature.

$$\text{ESEER} = (A \times \text{EER}100\%) + (B \times \text{EER}75\%) + (C \times \text{EER}50\%) + (D \times \text{EER}25\%)$$

	A	B	C	D
Coefficient	0.03 (3%)	0.33 (33%)	0.41 (41%)	0.23 (23%)
Air inlet condenser temperature	35°C	30°C	25°C	20°C

FTA_1-2-3a_Rev.01_2

10 Specification text

10 - 1 Specification Text

Sound levels

The range is available in four different sound level configurations:

S: Standard sound

Condenser fan rotating at 890 rpm, rubber antivibration under compressor

L: Low sound

Condenser fan rotating at 900 rpm (EWAD180-370D-SL) and 705 rpm (EWAD400-530D-SL), rubber antivibration under compressor.

R: Reduced sound

Condenser fan rotating at 680 rpm (EWAD180-370D-SR) and 705 rpm (EWAD400-530D-SR), rubber antivibration under compressor, compressor sound enclosure.

X: Extra low sound

Condenser fan rotating at 500 rpm, rubber antivibration under compressor, compressor and evaporator sound enclosure.

10 Specification text

10 - 1 Specification Text

General characteristics

Cabinet and structure

The cabinet is made of galvanized steel sheet and painted to provide a high resistance to corrosion. Colour Ivory White (Munsell code 5Y7.5/1) (±RAL7044). The base frame has an eye-hook to lift the unit with ropes for an easy installation. The weight is uniformly distributed along the profiles of the base and this facilitates the arrangement of the unit.

Screw compressors with integrated oil separator

The range features two types of single-screw compressors:

A) The compressor is semi-hermetic, single-screw type with gate-rotors made of carbon impregnated engineered composite material. The compressor has one slide managed by the unit microprocessor for infinitely modulating the capacity between 100% to 25%. An integrated high efficiency oil separator maximizes the oil separation and standard start is Wye-delta (Y-Δ) type.

This compressor is offered on following models:

- EWAD180~370D-SL
- EWAD180~370D-SR
- EWAD210~310D-SX
- EWAD250~400D-XS
- EWAD240~390D-XR
- EWAD200~380D-HS

B) The compressor is semi-hermetic, single-screw type with gate-rotor made with the latest high-strength fibre reinforced star material. The compressor has an asymmetric slide regulation managed by the unit controller for infinitely modulating capacity from 100% to 25%. An integrated high efficiency oil separator maximizes the oil separation and standard start is Wye-delta (Y-Δ) type.

This compressor is offered on following models:

- EWAD390~580D-SS
- EWAD400~530D-SL
- EWAD400~530D-SR
- EWAD370~490D-SX
- EWAD470~620D-XS
- EWAD460~600D-XR
- EWAD420~590D-HS

Ecological R-134a refrigerant

The compressors have been designed to operate with R-134a, ecological refrigerant with zero ODP (Ozone Depletion Potential) and very low GWP (Global Warming Potential), resulting in low TEWI (Total Equivalent Warming Impact).

Evaporator

For size EWAD180~200D-SL, EWAD180~190D-SR and EWAD200~210D-HS

The units are equipped with a direct expansion plate to plate type evaporator. This heat exchanger is made of stainless steel brazed plates and is covered with a 20mm closed cell insulation material. The exchanger is equipped with a heater for protection against freezing down to -28°C and evaporator water outlet connections of 3". Each evaporator has 2 circuits, one for each compressor and is manufactured in accordance to PED approval. Water pressure differential switch on evaporator standard factory mounted. Water filter is standard.

All the other units are equipped with a Direct Expansion shell&tube evaporator with copper tubes rolled into steel tubesheets. The evaporators are single-pass on both the refrigerant and water sides for pure counter-flow heat exchange and low refrigerant pressure drops. Both attributes contribute to the heat exchanger effectiveness and total unit's outstanding efficiency.

The external shell is covered with a 10mm closed cell insulation material and the evaporator water outlet connections are provided with victaulic kit (as standard). Each evaporator has 2 circuits, one for each compressor and is manufactured in accordance to PED approval.

Condenser coils

The condenser is manufactured with internally enhanced seamless copper tubes arranged in a staggered row pattern and mechanically expanded into lanced and rippled aluminium condenser fins with full fin collars. An integral sub-cooler circuit provides sub-cooling to effectively eliminate liquid flashing and increase cooling capacity without increasing the power input.

GNC_1a-2-3-4-5-6_Rev.01_1

10 Specification text

10 - 1 Specification Text

10

Condenser coil fans

Fan 710 mm diameter

The condenser fans are propeller type with wing-profile blades for achieving better performance. Each fan is protected by a guard.

Fan 800 mm diameter

The condenser fans are propeller type with high efficiency design blades to maximize performances. The material of the blades is glass reinforced resin and each fan is protected by a guard.

Fan motors are protected by circuit breakers (installed inside the electrical panel as a standard) and are IP54.

Electronic expansion valve

The unit is equipped with the most advanced electronic expansion valves to achieve precise control of refrigerant mass flow. As today's system requires improved energy efficiency, tighter temperature control, wider range of operating conditions and incorporate features like remote monitoring and diagnostics, the application of electronic expansion valves becomes mandatory.

Electronic expansion valves possess unique features: short opening and closing time, high resolution, positive shut-off function to eliminate use of additional solenoid valve, continuous modulation of mass flow without stress in the refrigerant circuit and corrosion resistance stainless steel body.

Electronic expansion valves are typically working with lower ΔP between high and low pressure side, than a thermostatic expansion valve. The electronic expansion valve allows the system to work with low condenser pressure (winter time) without any refrigerant flow problems and with a perfect chilled water leaving temperature control.

Refrigerant circuit

Each unit has 2 independent refrigerant circuits and each one includes:

- Compressor with integrated oil separator
- Air Cooled Condenser
- Electronic expansion valve
- Evaporator
- Discharge line shut off valve
- Liquid line shut off valve
- Suction line shut off valve
- Sight glass with moisture indicator
- Filter drier
- Charging valves
- High pressure switch
- High and low pressure transducers

Electrical control panel

Power and control are located in the main panel that is manufactured to ensure protection against all weather conditions. The electrical panel is IP54 and (when opening the doors) internally protected with plexiglas panel against possible accidental contact with electrical components (IP20). The main panel is fitted with a main switch interlocked door.

Power Section

The power section includes compressors fuses, fan circuit breaker, fan contactors and control circuit transformer.

MicroTech III controller

MicroTech III controller is installed as standard; it can be used to modify unit set-points and check control parameters. A built-in display shows chiller operating status plus temperatures and pressures of water, refrigerant and air, programmable values, set-points.

A sophisticated software with predictive logic, selects the most energy efficient combination of compressors, EEXV and condenser fans to keep stable operating conditions to maximise chiller energy efficiency and reliability.

MicroTech III is able to protect critical components based on external signs from its system (such as motor temperatures, refrigerant gas and oil pressures, correct phase sequence, pressure switches and evaporator). The input coming from the high pressure switch cuts all digital output from the controller in less than 50ms, this is an additional security for the equipment.

Fast program cycle (200ms) for a precise monitoring of the system. Floating point calculations supported for increased accuracy in P/T conversions.

GNC_1a-2-3-4-5-6_Rev.01_2

10 Specification text

10 - 1 Specification Text

Control section - main features

- Management of the compressor stepless capacity and fans modulation.
- Chiller enabled to work in partial failure condition.
- Full routine operation at condition of:
 - high ambient temperature value
 - high thermal load
 - high evaporator entering water temperature (start-up)
- Display of evaporator entering/leaving water temperature.
- Display of Outdoor Ambient Temperature.
- Display of condensing-evaporating temperature and pressure, suction and discharge superheat for each circuit.
- Leaving water evaporator temperature regulation (temperature tolerance = 0.1°C)
- Compressor and evaporator pumps hours counter.
- Display of Status Safety Devices.
- Number of starts and compressor working hours.
- Optimized management of compressor load.
- Fan management according to condensing pressure.
- Re-start in case of power failure (automatic / manual).
- Soft Load (optimized management of the compressor load during the start-up).
- Start at high evaporator water temperature.
- Return Reset (Set Point Reset based on return water temperature).
- OAT (Outside Ambient temperature) Reset.
- Set point Reset (optional).
- Application and system upgrade with commercial SD cards.
- Ethernet port for remote or local servicing using standard web browsers.
- Two different sets of default parameters could be stored for easy restore.

Safety device / logic for each refrigerant circuit

- High pressure (pressure switch).
- High pressure (transducer).
- Low pressure (transducer).
- Fans circuit breaker.
- High compressor discharge temperature.
- High motor winding temperature.
- Phase Monitor.
- Low pressure ratio.
- High oil pressure drop
- Low oil pressure.
- No pressure change at start.

System security

- Phase monitor.
- Low Ambient temperature lock-out.
- Freeze protection.

Regulation type

Proportional + integral + derivative regulation on the evaporator leaving water output probe.

10 Specification text

10 - 1 Specification Text

10

Condensing pressure

Condensing pressure can be controlled in according to the entering air temperature to the condenser coil. The fans can be managed either with steps, or with a 0/10V modulating signal or with a mixed 0/10V + Steps strategy to cover all possible operational conditions.

MicroTech III

MicroTech III built-in terminal has the following features:

- 164x44 dots liquid crystal display with white back lighting. Supports Unicode fonts for multi-lingual.
- Key-pad consisting of 3 keys.
- Push'n'Roll control for an increased usability.
- Memory to protect the data.
- General faults alarm relays.
- Password access to modify the setting.
- Application security to prevent application tampering or hardware usability with third party applications.
- Service report displaying all running hours and general conditions.
- Alarm history memory to allow an easy fault analysis.

Supervising systems (on request)

MicroTech III remote control

MicroTech III is able to communicate to BMS (Building Management System) based on the most common protocols as:

- ModbusRTU
- LonWorks, now also based on the international 8040 Standard Chiller Profile and LonMark Technology
- BacNet BTP certified over IP and MS/TP (class 4) (Native)
- Ethernet TCP/IP.

Standard options (supplied on basic unit)

Evaporator victaulic kit – Not available on units EWAD180~200D-SL, EWAD180~190D-SR and EWAD200~210D-HS

Evaporator water design pressure (10Bar)

Discharge line shut off valves – Installed on the discharge port of the compressor to facilitate maintenance operation.

Suction line shut off valve – Installed on the suction port of the compressor to facilitate maintenance operation.

Wye-Delta Compressors starter (Y-Δ) – For low inrush current and reduced starting torque.

Double set-point – Dual leaving water temperature set-points.

Phase monitor – The phase monitor controls that phases sequence is correct and controls phase loss.

Water pressure differential switch on evaporator – Not available on units EWAD390~580D-SS, EWAD230~530D-SL, EWAD220~530D-SR, EWAD210~490D-SX, EWAD250~620D-XS, EWAD240~600D-XR, EWAD230~590D-HS

Evaporator electric heater type – Electric heater controlled by a thermostat to protect the evaporator from freezing down to -28°C ambient temperature, providing the power supply is on.

Electronic expansion device

20 mm evaporator insulation – Only for EWAD180~200D-SL, EWAD180~190D-SR, EWAD210D-SX and EWAD200~210D-HS

Ambient outside temperature sensor and set-point reset

Hour run meter

General fault contactor – Alarm relay.

Set-point reset – The leaving water temperature set-point can be overwritten with the following options: 4-20mA from external source (by user); outside ambient temperature; evaporator water temperature Δt.

Demand limit – User can limit the load of the unit by 4-20mA signal or by network system

Alarm from external device – Microprocessor is able to receive an alarm signal from an external device (pump etc...). User can decide if this alarm signal will stop the unit or not.

Fans circuit breakers – Safety device against motor overloading and short circuit

Main switch interlock door

10 Specification text

10 - 1 Specification Text

Options (on request)

Total heat recovery – Provided with plate to plate heat exchangers to produce hot water.

Total heat recovery (1 circuit)

Partial heat recovery – Plate to plate heat exchangers installed between the compressor discharge and the condenser coil, allowing producing hot water.

Brine version – Allows the unit to operate down to -15°C leaving liquid temperature (antifreeze required).

Evaporator flanged connections – Not available for EWAD180~200D-SL, EWAD180~190D-SR, EWAD210D-SX and EWAD200~210D-HS

Condenser coil guards

Cu-Cu condensing coils – To give better protection against corrosion by aggressive environments.

Cu-Cu-Sn condensing coils – To give better protection against corrosion in aggressive environments and by salty air.

Alucoat condensing coils – Fins are protected by a special acrylic paint with a high resistance to corrosion.

Hydronic Kit (single water pump - low or high lifting) – (N.A. on EWAD210~490D-SX) Hydronic kit consists of: single direct driven centrifugal pump, water filling system with pressure gauge, safety valve, drain valve. The pump motor is protected by a circuit breaker installed in control panel. The kit is assembled and wired to the control panel. The pipe and pump are protected from freezing with an additional electrical heater.

Hydronic Kit (twin water pumps - low or high lifting) – (N.A. on EWAD180~190D-SR and on EWAD210~490D-SX). Hydronic kit consists of: twin direct driven centrifugal pumps, water filling system with pressure gauge, safety valve, drain valve. The motor pump is protected by a circuit breaker installed in control panel. The kit is assembled and wired to the control panel. The pipe and pumps are protected from freezing with an additional electrical heater.

Double pressure relief valve with diverter

Soft starter – Electronic starting device to reduce the mechanical stress during compressor start-up.

Compressor thermal overload relays – Safety devices against compressor motor overloading. This device together with internal motor protection (standard) guarantee the best safety system for compressor motor.

Under/Overvoltage control – This device control the voltage value of power supply and stop the chiller if the value exceeds the allowed operating limits.

Energy Meter – This device allows to measure the energy absorbed by the chiller during its life. It is installed inside the control box mounted on a DIN rail and show on a digital display: Line-to-Line Voltage, Phase and Average Current, Active and Reactive Power, Active Energy, Frequency.

Capacitors for power factor correction – To increase the operating power factor of the unit at nominal operating conditions. The capacitors are “dry” self-regenerating type with over pressure disconnecting safety device insulated with a no toxic dielectric mix with no PCB or PCT.

Current limit – To limit maximum absorbed current of the unit whenever is required.

Fan silent mode

Speedtrol – (N.A. on EWAD210~490D-SX) Continuous fan speed modulation on the first fan of each circuit. It allows the unit working with air temperature down to -18°C.

Evaporator flow switch – Supplied separately to be wired and installed on the evaporator water piping (by the customer).

High pressure side manometers (one per circuit)

Compressors circuit breakers

Fan speed regulation – Standard option for EWAD~D-SX

To control the fan speed revolution for smooth operating control of the unit. During low ambient temperature operation, this option improves also the sound level of the unit. With “Fan speed regulation” option, by different microprocessor setting, it is also possible to set the “Fan Silent Mode” configuration. It means that the microprocessor clock switches the fan at low speed according to the client setting (i.e. Night & Day), providing that the ambient temperature/condensing pressure is allowing the speed change. It allows a perfect condensing control down to -10°C.

10 Specification text

10 - 1 Specification Text

10

Rubber type anti vibration mounts – Supplied separately, these are positioned under the base of the unit during installation to reduce vibrations.

Spring type anti vibration mounts – Supplied separately, these are positioned under the base of the unit during installation. Ideal for dampening vibrations for installation on roofs and metallic structures.

External tank without cabinet (500 L / 1000 L)

External tank with cabinet (500 L / 1000 L)

Container kit

Witness test – Every unit is always tested at the test bench prior to the shipment. On request, a second test can be carried out, at customer's presence, in accordance with the procedures indicated on the test form (please contact the factory) (This test is not available for units with glycol mixtures).

Acoustic test – On request, a test can be carried out, at customer's presence (please contact the factory) (This test is not available for units with glycol mixtures).

10 Specification text

10 - 1 Specification Text

Technical Specification for Water Cooled Screw Chiller

GENERAL

The air cooled screw chiller will be designed and manufactured in accordance with following European directives:

Construction of pressure vessel	97/23/EC (PED)
Machinery Directive	2006/42/EC
Low Voltage	2006/95/EC
Electromagnetic Compatibility	2004/108/EC
Electrical & Safety codes	EN 60204-1 / EN 60335-2-40
Manufacturing Quality Stds	UNI – EN ISO 9001:2004

To avoid any losses, the unit will be tested at full load in the factory (at the nominal working conditions and water temperatures). The chiller will be delivered to the job site completely assembled and charged with refrigerant and oil. The installation of the chiller must comply with the manufacturer’s instructions for rigging and handling equipment.

The unit will be able to start up and operate (as standard) at full load with:

- outside air temperature from °C to °C
- evaporator leaving fluid temperature between °C and °C

REFRIGERANT

Only R-134a can be used.

PERFORMANCE

- ✓ Number of air cooled screw chiller(s) : unit(s)
- ✓ Cooling capacity for single air cooled screw chiller : kW
- ✓ Power input for single air cooled screw chiller in cooling mode : kW
- ✓ Heat exchanger entering water temperature in cooling mode : °C
- ✓ Heat exchanger leaving water temperature in cooling mode : °C
- ✓ Heat exchanger water flow : l/s
- ✓ Nominal outside working ambient temperature in cooling mode : °C

Operating voltage range should be 400V ±10%, 3ph, 50Hz, voltage unbalance maximum 3%, without neutral conductor and shall only have one power connection point.

UNIT DESCRIPTION

The chiller includes as standard not less than: two independent refrigerant circuits, semi-hermetic type rotary single screw compressor, electronic expansion device (EEXV), refrigerant ‘plate to plate’ or ‘shell&tube’ heat exchanger (depending on the size), air-cooled condenser section, R-134a refrigerant, lubrication system, motor starting components, discharge line shut-off valve, suction line shut-off valve, control system and all components necessary for a safe and stable unit operation.

The chiller will be factory assembled on a robust base frame made of galvanized steel, protected by an epoxy paint.

NOISE LEVEL AND VIBRATIONS

Sound pressure level at 1 meter distance in free field, semispheric conditions, shall not exceeddB(A). The sound pressure levels must be rated in accordance to ISO 3744 (other types of rating can not be used).

Vibration on the base frame should not exceed 2 mm/s.

10 Specification text

10 - 1 Specification Text

10

DIMENSIONS

Unit dimensions shall not exceed following indications:

- Unit length mm
- Unit width mm
- Unit height mm

CHILLER COMPONENTS

Compressors

- ✓ The compressor is semi-hermetic, single-screw type with gate-rotors made of carbon impregnated engineered composite material or the latest high-strength fibre reinforced star material (depending on the size). The gaterotor supports will be constructed of cast iron.
- ✓ The oil injection shall be used in order to get high EER (Energy Efficiency Ratio) also at high condensing pressure and low sound pressure levels in each load condition.
- ✓ The compressor shall be provided with a built in, high efficiency, mesh type oil separator and oil filter.
- ✓ Refrigerant system differential pressure shall provide oil injection on all moving compressor parts to correctly lubricate them. Electrical oil pump lubricating system is not allowed.
- ✓ Compressor cooling must be done by refrigerant liquid injection. An external dedicated heat exchanger and additional piping to carry the oil from compressor to heat exchanger and viceversa is not allowed.
- ✓ The compressor shall be direct electrical driven, without gear transmission between the screw and the electrical motor.
- ✓ The compressor casing shall be provided with ports to realize economized refrigerant cycles.
- ✓ The compressor must be protected by a temperature sensor for high discharge temperature and an electrical motor thermistor for high winding temperature.
- ✓ The compressor shall be equipped with an electric oil heater.
- ✓ The compressor shall be fully field serviceable. Compressor that must be removed and returned to the factory for service shall be unacceptable.

Cooling capacity control system

- ✓ Each chiller will have a microprocessor for the control of the compressor slide valve position.
- ✓ The unit capacity control shall be infinitely modulating, from 100% down to 25% for each circuit. The chiller shall be capable of stable operation to a minimum of 12.5% of full load without hot gas bypass.
- ✓ The system shall control the unit based on the leaving evaporator water temperature that shall be controlled by PID (Proportional Integral Derivative) logic.
- ✓ The unit control logic shall manage the compressor slides to exactly match the plant load request in order to keep constant the set point for delivered chilled water temperature.
- ✓ The microprocessor unit control shall detect conditions that approach protective limits and take self-corrective action prior to an alarm occurring. The system shall automatically reduce the chiller capacity when any of the following parameters are outside their normal operating range:
 - High condenser pressure
 - Low evaporating refrigerant temperature

Evaporator

- ✓ The units shall be equipped (depending on the size) with a 'plate to plate' or 'shell&tube' evaporator:
 - The 'plate to plate' evaporator is made of stainless steel brazed plates and is covered with a 20mm closed cell insulation material. The exchanger is equipped with a heater for protection against freezing down to -28°C and evaporator water outlet connections of 3". Each evaporator has 1 circuit (one compressor) and the water filter is standard.
 - The 'shell&tube' evaporator is made with copper tubes rolled into steel tubesheets. The evaporators are single-pass on both the refrigerant and water sides for pure counter-flow heat exchange and low refrigerant pressure drops. The external shell is covered with a 10mm closed cell insulation material and the evaporator water outlet connections are provided with victaulic kit (as standard). Each evaporator has 2 circuits, one for each compressor and the water filter is standard.
- ✓ The evaporator is manufactured in accordance to PED approval.

SPC_1-2-3-4_Rev.00_2

10 Specification text

10 - 1 Specification Text

Condenser coil

- ✓ The condenser coils are constructed with internally finned seamless copper tubes and arranged in a staggered row pattern and mechanically expanded into lanced and rippled aluminium fins with full fin collars for higher efficiencies. The space between the fins is given by a collar that will increase the surface area in connection with the tubes, protecting them from ambient corrosion.
- ✓ The condenser coils will have an integral subcooler circuit that provides sufficient subcooling to effectively eliminate the possibility of liquid flashing and increase the unit's efficiency with 5% to 7% without increasing in energy consumption.
- ✓ The condenser coils shall be leak-tested and submitted to a pressure test with dry air.

Condenser fans

- ✓ The condenser fans used in conjunction with the condenser coils, shall be propeller type with glass reinforced resin blades for higher efficiencies and lower sound. Each fan shall be protected by a fan guard.
- ✓ The air discharge shall be vertical and each fan must be coupled to the electrical motor, supplied as standard to IP54 and capable to work to ambient temperatures of - 20°C to + 65°C.
- ✓ The condenser fans shall have as a standard a thermally protection by internal thermal motor protection and protected by circuit breaker installed inside the electrical panel as a standard.

Refrigerant circuit

- ✓ The unit shall have two independent refrigerant circuits.
- ✓ Each circuit shall include as standard: electronic expansion device piloted by unit's microprocessor control, compressor discharge shut-off valve, suction shut-off valve, replaceable core filter-drier, sight glass with moisture indicator and insulated suction line.

Condensation control

- ✓ The units will be provided with an automatic control for condensing pressure which ensures the working at low external temperatures down to - °C, to maintain condensing pressure.
- ✓ The compressor automatically unloads when abnormal high condensing pressure is detected. This to prevent the shutdown of the refrigerant circuit (shutdown of the unit) due to a high-pressure fault.

Low sound unit configurations (on request)

- ✓ The unit compressor shall be connected with unit's metal base frame by rubber antivibration supports to prevent the transmission of vibrations to all metal unit structure, in order to control the unit sound.
- ✓ The chiller shall be provided with an acoustical compressor enclosure. This enclosure shall be realized with a light, corrosion resisting aluminium structure and metal panels. The compressor sound-proof enclosure shall be internally fitted with flexible, multi-layer, high density materials.

Hydronic kit options (on request)

- ✓ The hydronic module shall be integrated in the chiller chassis without increasing its dimensions and includes the following elements: centrifugal water pump with three-phase motor equipped with internal over-temperature protection, safety relief valve and filling kit.
- ✓ The water piping shall be protected against corrosion and equipped with drain and purge plugs. The customer connections shall be Victaulic connections. The piping shall be fully insulated to prevent condensation (pump insulation using polyurethane foam).
- ✓ A choice of two pump types shall be available:
 - in-line single pump low and high lifting
 - in-line twin pumps low and high lifting

10 Specification text

10 - 1 Specification Text

10

Control panel

- ✓ Field power connection, control interlock terminals and unit control system should be centrally located in an electric panel (IP 54). Power and starting controls should be separated from safety and operating controls in different compartments of the same panel.
- ✓ Starting will be Wye-Delta type (Y-Δ).
- ✓ Operating and safety controls should include energy saving control, emergency stop switch, overload protection for compressor motor, high and low pressure cut-out switch (for each refrigerant circuit), anti-freeze thermostat, cut-out switch for each compressor.
- ✓ All of the information regarding the unit will be reported on a display, and with the internal built-in calendar and clock that will switch the unit ON/OFF during day time all year long.
- ✓ The following features and functions shall be included:
 - leaving water temperature reset by controlling the water temperature Δt , by a remote 4-20mA DC signal or by controlling the external ambient temperature;
 - soft load function to prevent the system from operating at full load during the chilled fluid pulldown period;
 - password protection of critical parameters of control;
 - start-to-start and stop-to-start timers to provide minimum compressor off-time with maximum motor protection;
 - communication capability with a PC or remote monitoring;
 - discharge pressure control through intelligent cycling of condenser fans;
 - lead-lag selection manual or automatically by circuit run hours;
 - double set point for brine unit version;
 - scheduling via internal time clock to allow programming of a yearly start-stop schedule accommodating weekends and holidays.

Optional High Level Communications Interface

- ✓ The chiller is able to communicate to BMS (Building Management System) based on the most common protocols as:
 - ModbusRTU
 - LonWorks, now also based on the international 8040 Standard Chiller Profile and LonMark Technology
 - BacNet BTP certified over IP and MS/TP (class 4) (Native)
 - Ethernet TCP/IP



Daikin's unique position as a manufacturer of air conditioning equipment, compressors and refrigerants has led to its close involvement in environmental issues. For several years Daikin has had the intention to become a leader in the provision of products that have limited impact on the environment. This challenge demands the eco design and development of a wide range of products and an energy management system, resulting in energy conservation and a reduction of waste.



Daikin Europe N.V. participates in the Eurovent Certification programme for Air conditioners (AC), Liquid Chilling Packages (LCP) and Fan coil units (FCU). Check on-going validity of certificate online: www.eurovent-certification.com or using: www.certiflash.com

The present leaflet is drawn up by way of information only and does not constitute an offer binding upon Daikin Europe N.V.. Daikin Europe N.V. has compiled the content of this leaflet to the best of its knowledge. No express or implied warranty is given for the completeness, accuracy, reliability or fitness for particular purpose of its content and the products and services presented therein. Specifications are subject to change without prior notice. Daikin Europe N.V. explicitly rejects any liability for any direct or indirect damage, in the broadest sense, arising from or related to the use and/or interpretation of this leaflet. All content is copyrighted by Daikin Europe N.V.

BARCODE

Daikin products are distributed by: