



# Applied Systems

# Technical Data

Condenserless chiller



EEDEN13-411

EWLP-KBW1N



# TABLE OF CONTENTS

## EWLP-KBW1N

1	Features .....	2
2	Specifications .....	3
	Technical Specifications .....	3
	Electrical Specifications .....	4
3	Options .....	5
	Options .....	5
4	Capacity tables .....	6
	Cooling Capacity Tables .....	6
	Capacity Correction Factor .....	7
5	Dimensional drawings .....	8
	Dimensional Drawings .....	8
6	Centre of gravity .....	10
	Centre of Gravity .....	10
7	Piping diagrams .....	11
	Piping Diagrams .....	11
8	Wiring diagrams .....	13
	Wiring Diagrams - Three Phase .....	13
9	Sound data .....	15
	Sound Power Spectrum .....	15
10	Operation range .....	16
	Operation Range .....	16
11	Hydraulic performance .....	18
	Water Pressure Drop Curve Evaporator .....	18

# 1 Features

- Daikin scroll compressor
- Optimised for use with R-407C
- Electronic DDC controller
- Low operating sound level
- Low energy consumption
- Compact dimensions and low refrigerant volume
- Easy installation and maintenance
- Stainless steel plate heat exchanger
- Compatible with hydraulic module
- Standard integrated: main switch, pressure ports, flow switch, filter, shut-off valves and air purge



1

2

## 2 Specifications

2-1 Technical Specifications				EWLP012KBW1N	EWLP020KBW1N	EWLP026KBW1N	EWLP030KBW1N	EWLP040KBW1N	EWLP055KBW1N	EWLP065KBW1N
Cooling capacity	Nom.		kW	12.1 (1)	20.0 (1)	26.8 (1)	31.2 (1)	40.0 (1)	53.7 (1)	62.4 (1)
Capacity steps number				1				2		
Power input	Cooling	Nom.	kW	4.2 (2)	6.6 (2)	8.5 (2)	10.1 (2)	13.4 (2)	17.8 (2)	20.3 (2)
EER				2.88 (1)	3.03 (1)	3.15 (1)	3.09 (1)	2.99 (1)	3.02 (1)	3.07 (1)
Casing	Material			Polyester painted steel plate						
Dimensions	Unit	Height	mm	600						
		Width	mm	600						
		Depth	mm	600				1,200		
Weight	Unit		kg	108	141	147	151	252	265	274
Water heat exchanger - evaporator	Minimum water volume in the system		l	62	103	134	155	205	268	311
	Type			Brazed plate						
	Water flow rate	Min.	l/min	31	53	65	76	101	131	152
		Nom.	l/min	35	57	77	89	115	154	179
		Max.	l/min	69	115	154	179	229	308	357
Insulation material			Polyethylene foam							
Model	Quantity			1						
Sound power level	Cooling	Nom.	dBA	64			71	67		74
Compressor	Type			Hermetically sealed scroll compressor						
	Quantity			1				2		
	Model			JT140BF- YE	JT212DA- YE	JT300DA- YE	JT335DA- YE	JT212DA- YE	JT300DA- YE	JT335DA- YE
	Speed		rpm	2,900						
	Crankcase heater		W	33						
Operation range	Evaporator	Cooling	Min.	°CDB						
			Max.	°CDB						
	Condenser	Cooling	Min.	°CDB						
			Max.	°CDB						
Refrigerant	Type			R-407C						
	Control			Thermostatic expansion valve						
	Circuits	Quantity		1				2		
Refrigerant circuit	N2 holding charge			Yes						
Refrigerant oil	Type			FVC68D						
	Charged volume		l	1.5	2.7					
Piping connections	Liquid line connection		mm	9.52	12.7			12.7+12.7		
	Liquid line connection (Type)			Flare connection						
	Discharge line connection		mm	12.7	19.1			19.1+19.1		
	Discharge line connection (Type)			Flare connection						
	Evaporator water inlet/outlet (OD)			FBSP 25mm				FBSP 40mm		
	Evaporator water drain			Field installation						

## 2 Specifications

2

2-2 Electrical Specifications			EWLP012KBW1N	EWLP020KBW1N	EWLP026KBW1N	EWLP030KBW1N	EWLP040KBW1N	EWLP055KBW1N	EWLP065KBW1N	
Compressor	Phase		3~							
	Frequency		50							
	Voltage		400							
	Starting current		A	49	79	109	129	79	109	129
	Nominal running current (RLA)		A	7.4	11.5	14.3	16.6	11.5	14.3	16.6
	Maximum running current		A	9	14.5	18.5	22	14	18	20
	Starting method		Direct on line							
Power supply	Name		W1							
	Phase		3N~							
	Frequency		50							
	Voltage		400							
	Voltage range	Min.	%	-10						
		Max.	%	10						
Unit	Starting current		A	49	79	109	129	93	127	149
	Current	Zmax	Text	0.27 + j0.17	0.22 + j0.13	0.19 + j0.12		0.20 + j0.12	0.18 + j0.12	0.18 + j0.11
	Nominal running current (RLA)	Cooling	A	7.4	11.5	14.3	16.6	23.0	28.7	33.3
	Maximum running current		A	9	14.5	18.5	22	28	36	40
	Recommended fuses according to IEC standard 269-2			3 x 16aM	3 x 20aM	3 x 25aM		3 x 35aM	3 x 40aM	3 x 50aM

### Notes

- (1) Cooling: entering evaporator water temp. 12°C; leaving evaporator water temp. 7°C; condensing temp. bubble 45°C; liquid temp. 40°C; standard: Eurovent 6/C/003; condensing temp. bubble corresponds to compressor discharge pressure.
- (2) Cooling: entering evaporator water temp. 12°C; leaving evaporator water temp. 7°C; condensing temp. bubble 45°C; liquid temp. 40°C; standard: Eurovent 6/C/003; condensing temp. bubble corresponds to compressor discharge pressure. This power input includes an addition for the required evaporator pump power input.
- (3) The nominal sound power level is measured according to ISO9614

### 3 Options

#### 3 - 1 Options

**EWWP-KBW1N**  
**EWLP-KBW1N**

Optional equipment for EWW/LP-KBW1\*

EWWP014KBW1N*	EWWP045KBW1N*	EWLP012KBW1N*	EWLP040KBW1N*
EWWP022KBW1N*	EWWP055KBW1N*	EWLP020KBW1N*	EWLP055KBW1N*
EWWP028KBW1N*	EWWP065KBW1N*	EWLP026KBW1N*	EWLP065KBW1N*
EWWP035KBW1N*		EWLP030KBW1N*	

Option number	Option description	Unit Size							availability
		014WC-012RC	022WC-020RC	028WC-026RC	035WC-030RC	045WC-040RC	055WC-055RC	065WC-065RC	
	Standard unit	•	•	•	•	•	•	•	
	<b>Not completely combinable options</b>								
ZH	Glycol application chilled water temperature down to -5°C	•	•	•	•	•	•	•	Fact. mount.
ZL	Glycol application chilled water temperature down to -10°C	•	•	•	•	•	•	•	Fact. mount.
	<b>Available kit</b>								
EKAC10C	Address card for connection to BMS or Remote user interface	•	•	•	•	•	•	•	kit
EKRUMCA	Remote installed user interface	•	•	•	•	•	•	•	kit
EKLS1	Low noise operation EWW/LP*(12/14)KBW1*	•1	-	-	-	-	-	-	kit
EKLS2	Low noise operation EWW/LP*(20-65)KBW1*	-	•1	•1	•1	•2	•2	•2	kit
EHMC10AV1010/1080	Hydraulic module	•	•	-	-	-	-	-	kit
EHMC15AV1010/1080	Hydraulic module	-	-	•	•	-	-	-	kit
EHMC30AV1010/1080	Hydraulic module	-	-	-	-	•	•	•	kit

4TW60149-5A

**NOTES**

- std = standard on unit  
 • = available  
 •x = available and quantity of x is need for this unit size  
 - = not available  
 Hatched area = preliminary data  
 \* = option number
- To install EKRUMCA => EKAC10C needs to be installed on the unit.
- EKAC10C: this address card allows direct connection to MODBUS BMS system





# 4 Capacity tables

## 4 - 2 Capacity Correction Factor

Required glycol concentration

Type	Concentration (wt%)	0	10	20	30	40
Ethylene glycol	Freezing point °C	0	-4	-9	-16	-23
	Minimum LWE °C	4	2	0	-5	-11
Propylene glycol	Freezing point °C	0	-3	-7	-13	-22
	Minimum LWE °C	4	3	-2	-4	-10

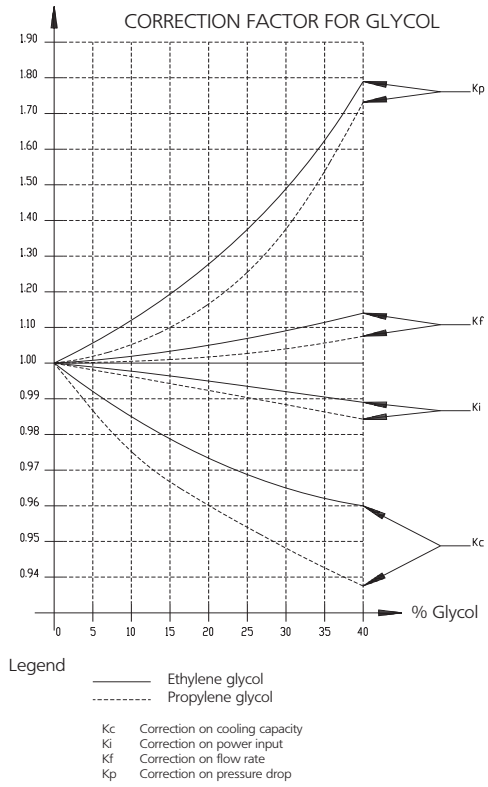

4TW54179-1

# 5 Dimensional drawings

## 5 - 1 Dimensional Drawings

5

EWLP012-030KBW1N

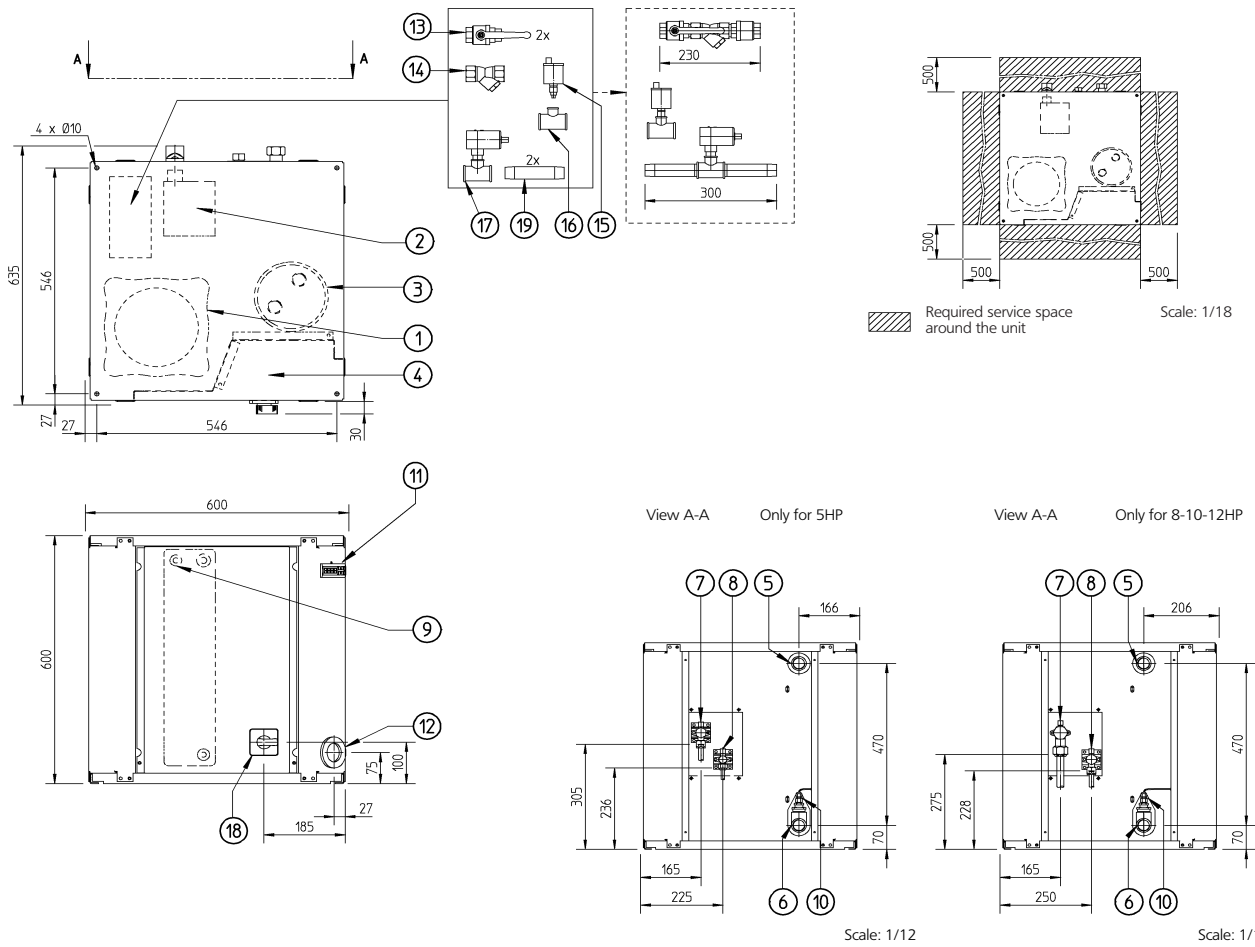

- |  |                               |
|--|-------------------------------|
| 1 Compressor                                   | 11 Digital display controller |
| 2 Evaporator                                   | 12 Power supply intake (φ 48) |
| 3 Accumulator                                  | 13 Ballvalve                  |
| 4 Switchbox                                    | 14 Water filter               |
| 5 Chilled water in                             | 15 Air purge                  |
| 6 Chilled water out                            | 16 T-joint for air purge      |
| 7 Discharge stop valve                         | 17 Flow switch                |
| 8 Liquid stop valve                            | 18 Main switch                |
| 9 Evaporator entering water temperature sensor | 19 Flow switch pipe           |
| 10 Freeze up sensor                            |                               |

3TW55254-2B

# 5 Dimensional drawings

## 5 - 1 Dimensional Drawings

EWLP040-065KBW1N

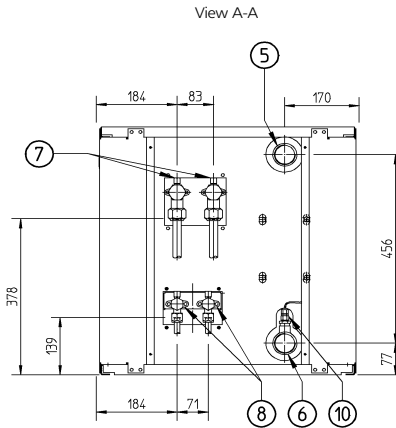
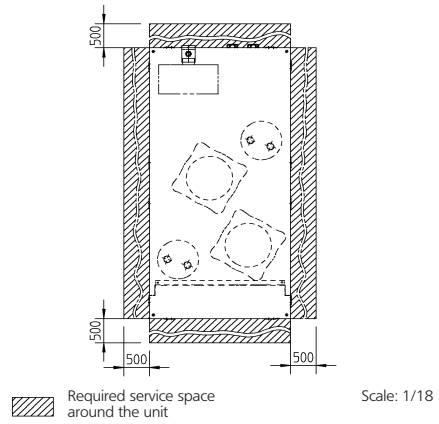
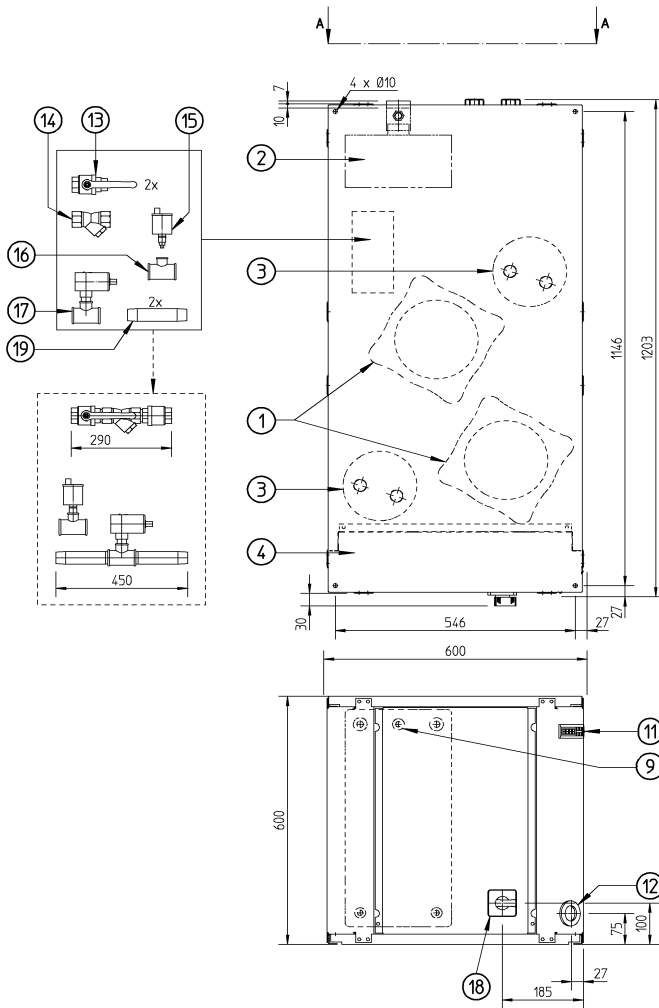

- |  |                               |
|--|-------------------------------|
| 1 Compressor                                   | 11 Digital display controller |
| 2 Evaporator                                   | 12 Power supply intake (Ø 48) |
| 3 Accumulator                                  | 13 Ballvalve                  |
| 4 Switchbox                                    | 14 Water filter               |
| 5 Chilled water in                             | 15 Air purge                  |
| 6 Chilled water out                            | 16 T-joint for air purge      |
| 7 Discharge stop valve                         | 17 Flow switch                |
| 8 Liquid stop valve                            | 18 Main switch                |
| 9 Evaporator entering water temperature sensor | 19 Flow switch pipe           |
| 10 Freeze up sensor                            |                               |

3TW55304-2B

## 6 Centre of gravity

### 6 - 1 Centre of Gravity

6

EWLP012-030KBW1N

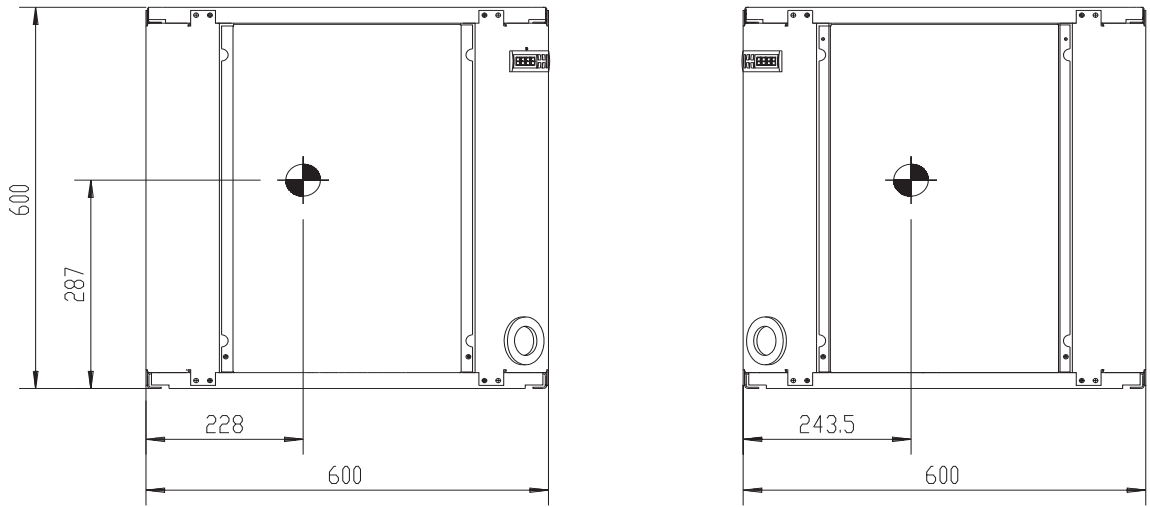

4TW54629-2

EWLP040-065KBW1N

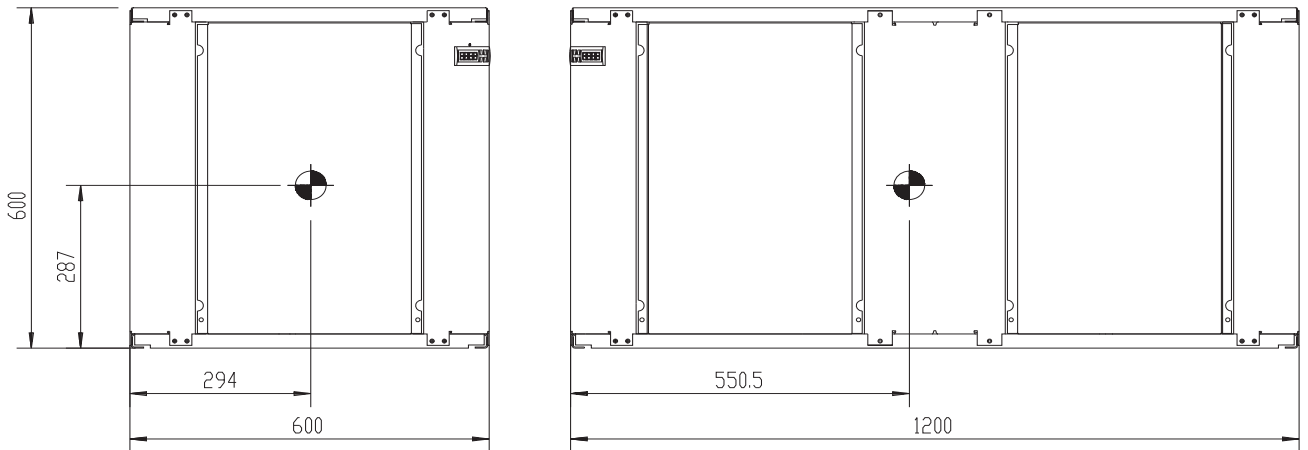

4TW54629-3

# 7 Piping diagrams

## 7 - 1 Piping Diagrams

EWLP012-030KBW1N

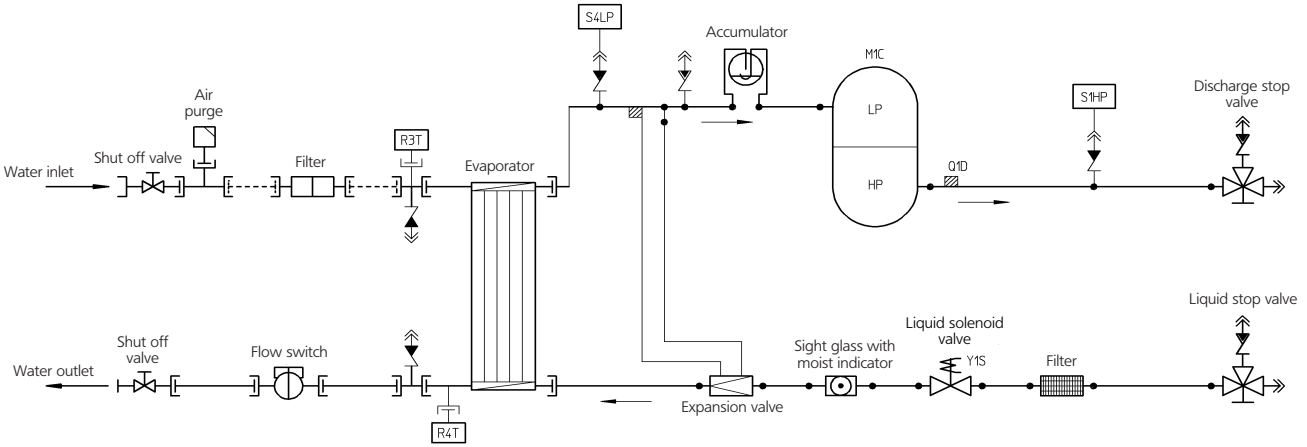

- Y1S Liquid solenoid valve
- M1C Compressor motor 1
- R4T Freeze-up protection
- S1HP High pressure switch
- S4LP Low pressure switch
- R3T Inlet water evap. temp. sensor
- Q1D Discharge temperature controller

- Field piping
- ↔ Check valve
- ↔ Flare connection
- ↔ Screw connection
- ↔ Flange connection
- ✕ Pinched pipe
- Spinned pipe

3TW55255-2B

# 7 Piping diagrams

## 7 - 1 Piping Diagrams

EWLP040-065KBW1N

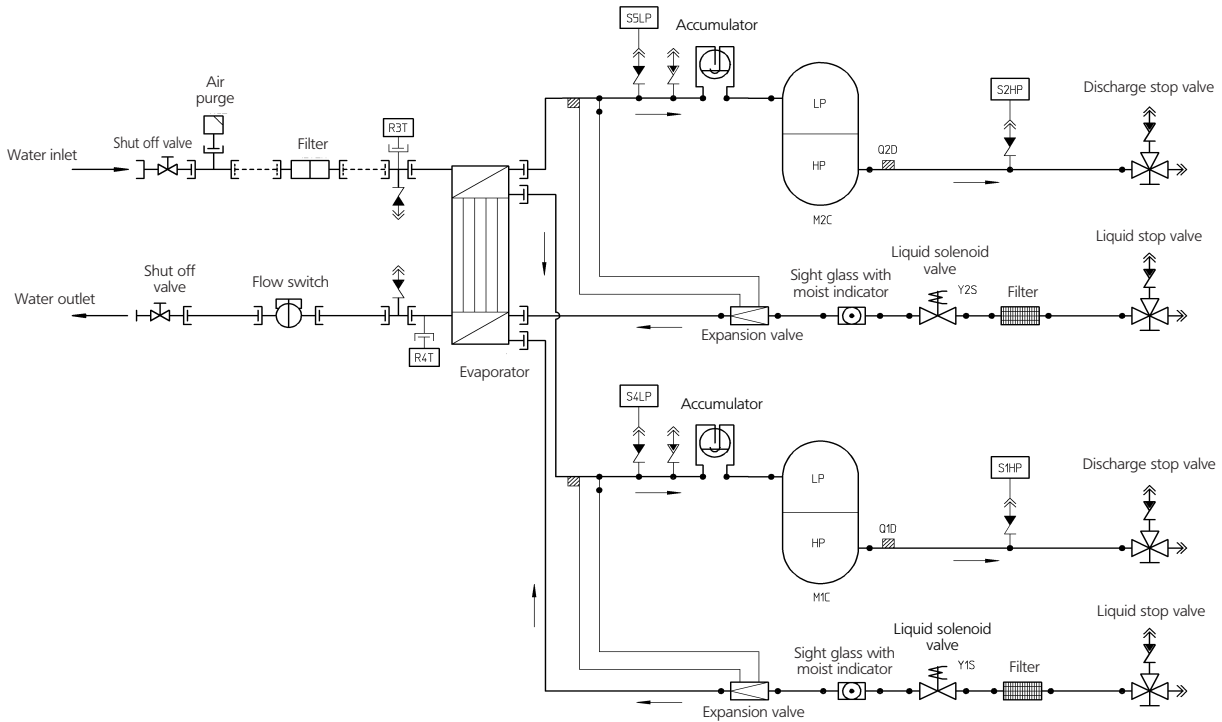

- Y1S Liquid solenoid valve
- Y2S Liquid solenoid valve
- M1C Compressor motor
- M2C Compressor motor
- R4T Freeze-up protection
- R5T Inlet water cond. temp. sensor
- S1HP High pressure switch
- S2HP High pressure switch
- S4LP Low pressure switch
- S5LP Low pressure switch
- R3T Inlet water evap. temp. sensor
- Q1D Discharge temperature controller
- Q2D Discharge temperature controller

- Field piping
- ↔ Check valve
- ← Flare connection
- ⊥ Screw connection
- ⊥ Flange connection
- ✕ Pinched pipe
- Spinned pipe

3TW55305-2B

# 8 Wiring diagrams

## 8 - 1 Wiring Diagrams - Three Phase

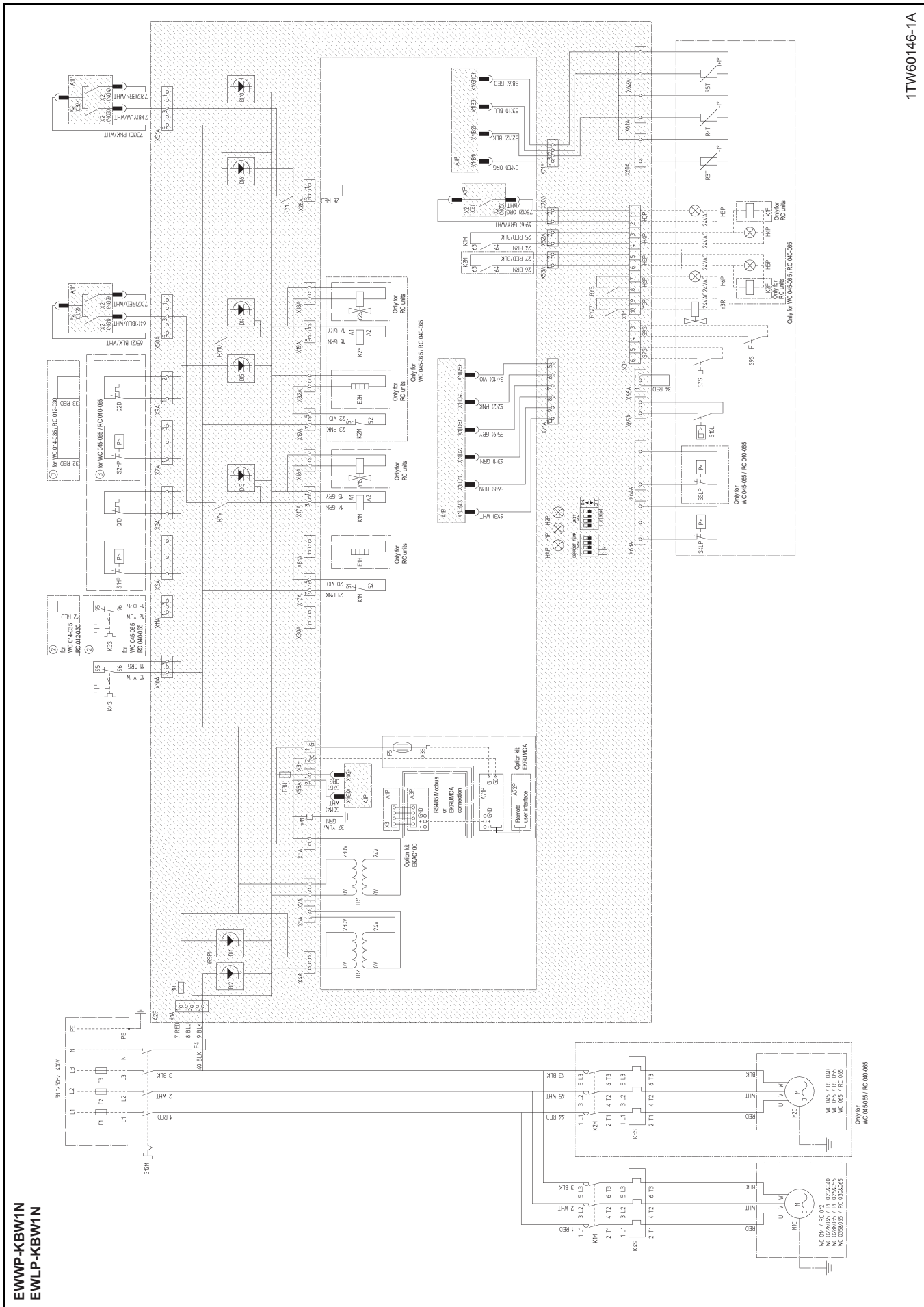

EWLP-KBW1N  
EWLP-KBW1N

1TW60146-1A

# 8 Wiring diagrams

## 8 - 1 Wiring Diagrams - Three Phase

8

### EWWP-KBW1N EWLP-KBW1N

Y3R*	Reverse valve of water circuit	R3T	Condensor inlet water temperature sensor	F3U	Fuse controller PCB
Y1S, Y2S	Liquid solenoid valve circuit 1, circuit 2	Q1D, Q2D	Discharge thermal protector circuit 1, circuit 2	F1U	Fuse I/O PCB
X1-82(A/B/M)	Connectors	PE	Main earth terminal	F6 #	Fuse for pumpcontactor
TR2	transfo 230V -> 24V for supply of I/O PCB	M1C, M2C	Compressor motor circuit 1, circuit 2	F5 ##	Surge proof fuse
TR1	transfo 230V -> 24V for supply of controller PCB	K1P*	Pump contractor	F4	Fuse I/O PCB
S12M	Main isolator switch	K1F, K2F #	Fan contactor	F1, F2, F3 #	Main fuses for the unit
S10L	Flowswitch	K6S*	Overcurrent relay pump	E1H, E2H	Crankcase heater circuit 1, circuit 2
S9S*	Switch for remote start/stop or dual setpoint	K4S, K5S	Overcurrent relay circuit 1, circuit 2	A72P**	PCB: power supply card
S7S*	Switch for remote cooling/heating selection or dual setpoint	K1M, K2M	Compressor contactor circuit 1, circuit 2	A71P**	PCB: remote user interface
S4LP, S5LP	Low pressure switch circuit 1, circuit 2	H6P*	Indication lamp general operation	A3P**	PCB: address card
S1HP, S2HP	High pressure switch circuit 1, circuit 2	H5P*	Indication lamp operation compressor 2	A2P	PCB: I/O PCB
R5T	Condensor inlet water temperature sensor	H4P*	Indication lamp operation compressor 1	A1P	PCB: controller PCB
R4T	Evaporator outlet water temperature sensor	H3P*	Indication lamp alarm		

A2P	A1P
<b>DIGITAL INPUTS</b> DI1 Reverse phase detection (L1-N) DI2 Reverse phase detection (N-L3) DI3 M1C ON detection DI4 M2C ON detection DI5 Safety device detection DI6 Pump ON detection DI7 -- DI8 -- DI9 -- DI10 Reverse valve request	<b>DIGITAL INPUTS</b> X1 (ID1-GND) : Flow switch X1 (ID2-GND) : Remote C/H selection X1 (ID3-GND) : High pressure switch + discharge protector + overcurrent X1 (ID4-GND) : Low pressure switch X1 (ID5-GND) : remote On/Off
<b>DIGITAL OUTPUTS (RELAYS)</b> RY1 Reversed phase protector RY3 Pump/general operation RY9 M1C off (during defrost) RY10 M2C off (during defrost) RY27 Reversing valve of water circuit	<b>DIGITAL OUTPUTS (RELAYS)</b> X2 (C1/2-NO1) : Compressor M1C on X2 (C1/2-NO2) : Compressor M2C on X2 (C3/4-NO3) : voltage free contact for pump X2 (C3/4-NO4) : Reversing valve X2 (C5-NO5) : alarm voltage free contact
<b>OTHERS</b> HAP light emitting diode (service monitor green) H1P, H2P light emitting diode (service monitor red)  S1A dipswitch (unit setting) S2A dipswitch (defr. & fan setting)	<b>ANALOG INPUTS</b> X1 (B1-GND): evap inlet water t° X1 (B2-GND): evap outlet water t° X1 (B3-GND): cond inlet water t°  <b>ANALOG OUTPUTS</b> X1 (Y-GND):

	All models (400V)						
	WC014 RC012	WC 022 RC020	WC028 RC026	WC035 RC030	WC045 RC040	WC055 RC055	WC065 RC065
Fuses + overcurrent							
F1, F2, F3 (+ gL/gG)	3x16A	3x20A	3x25A	3x32A	3x40A	3x50A	3x50A
F4	8A	8A	8A	8A	8A	8A	8A
F5	250mAT	250mAT	250mAT	250mAT	250mAT	250mAT	250mAT
F1U	5A	5A	5A	5A	5A	5A	5A
F3U	315mAT	315mAT	315mAT	315mAT	315mAT	315mAT	315mAT
K4S	9A	14.5A	18.5A	22A	14A	18A	20A
K5S	--	--	--	--	14A	18A	20A

	Not standard included	
	Not possible as option	Poss. as option
Obligatory	#	##
Not obligatory	*	**

1TW60146-1A

### NOTES

1. <sup>1</sup> : Terminal 1, <sup>2</sup> : Wire 2; -----: Field wiring to be in accordance with the local electrical regulations, -----: Earth wiring  
 □: Option, ▨: PCB □: Outside switchbox
- If compressor rotates reversely, it may be damaged
- WC: Watercooled chiller  
 RC: Unit with remote condenser
- Optional:  
 - EKAC10C = address card kit for Modbus or remote user interface connection  
 - EKSS = softstart  
 - EKSUMCA = remote user interface
- Terminals for fieldwiring:  
 X1M: H3-6P, Y3R, K1-2F: Output terminal for fieldwiring (voltage free contact max 2A/Output)  
 X3M: Input terminal for fieldwiring (don't connect voltage) (switch load 6mA/30VDC)
- Y3R is activated in cooling mode  
 S7S open = heating  
 S7S closed = cooling
- Dipswitch setting  
 S2A dipswitch: defrost & fan setting  
 no meaning for WC CO & WC CL CO

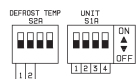

S1A dipswitch: Unit setting  
 1 > off = 1 circuit  
 on = 2 circuit  
 234 > Off Off Off = WC CO & WC CL CO  
 Off On Off = AC CO  
 On Off Off = AC HP (without compr stop for defrost cycle)  
 On Off On = AC HP (with compr stop for defrost cycle)

### 8. Pump contact

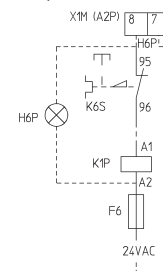



# 9 Sound data

## 9 - 1 Sound Power Spectrum

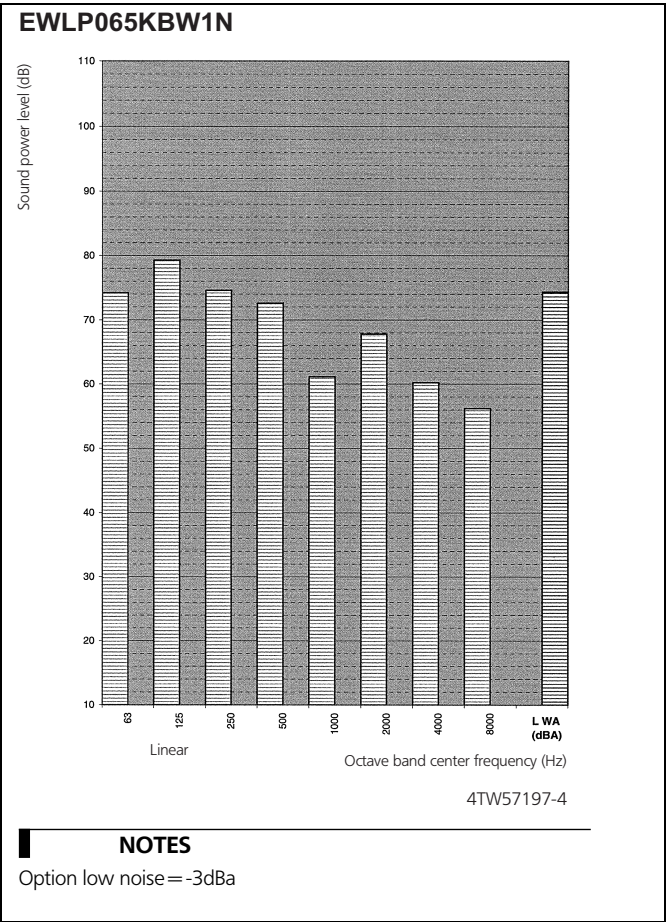
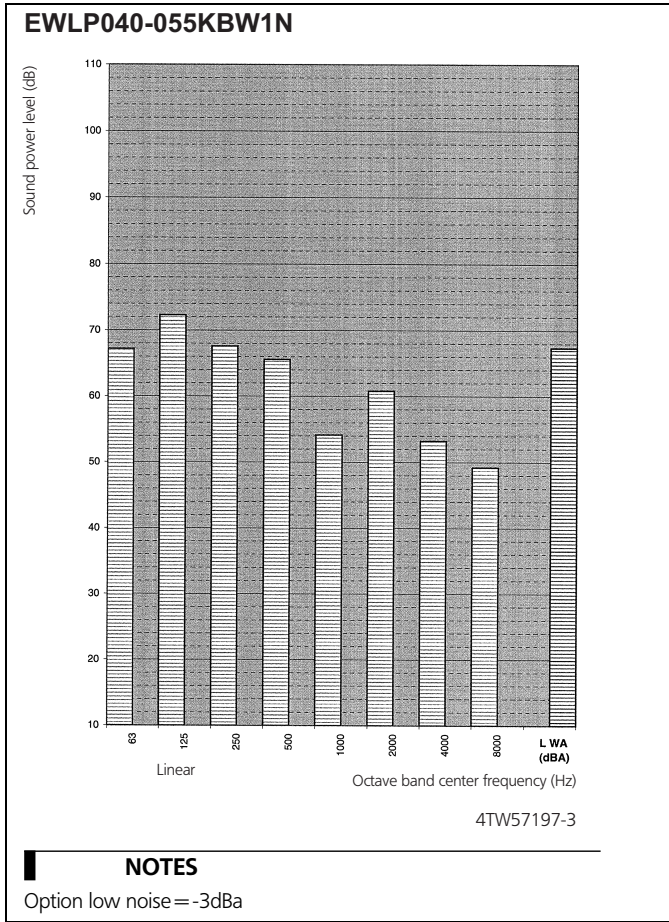
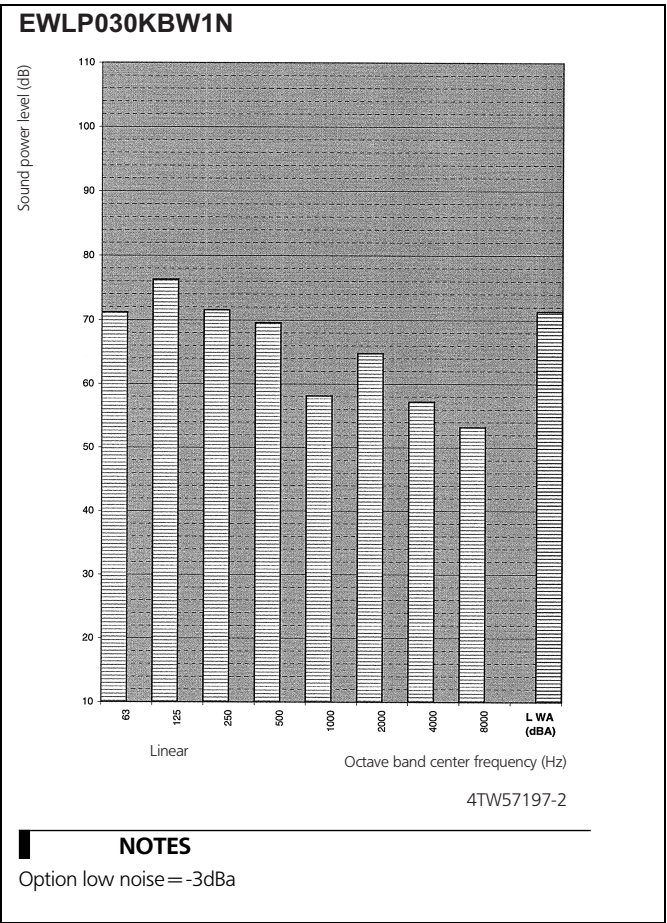
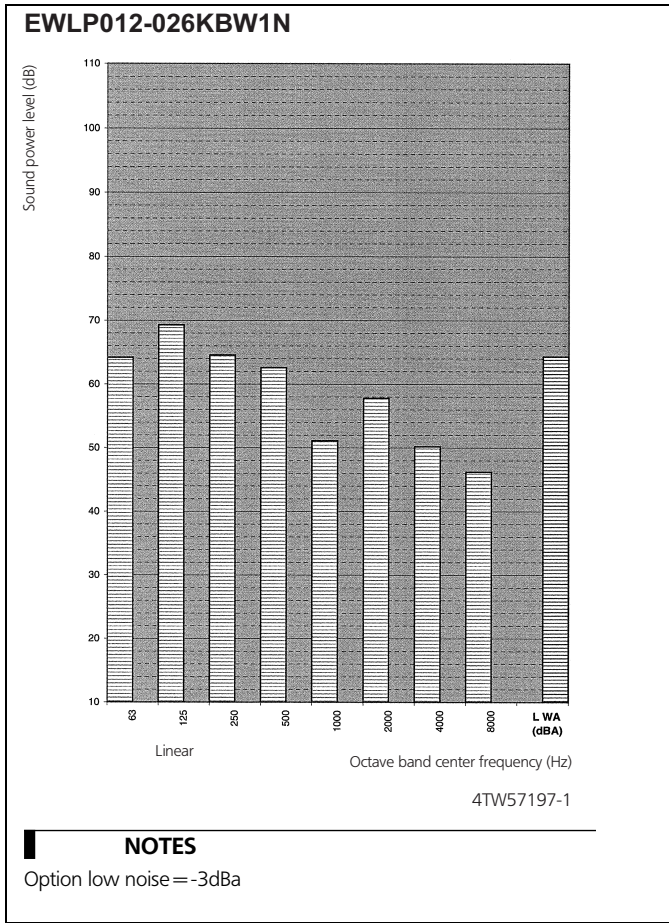

# 10 Operation range

## 10 - 1 Operation Range

10

EWLP012-030KBW1N

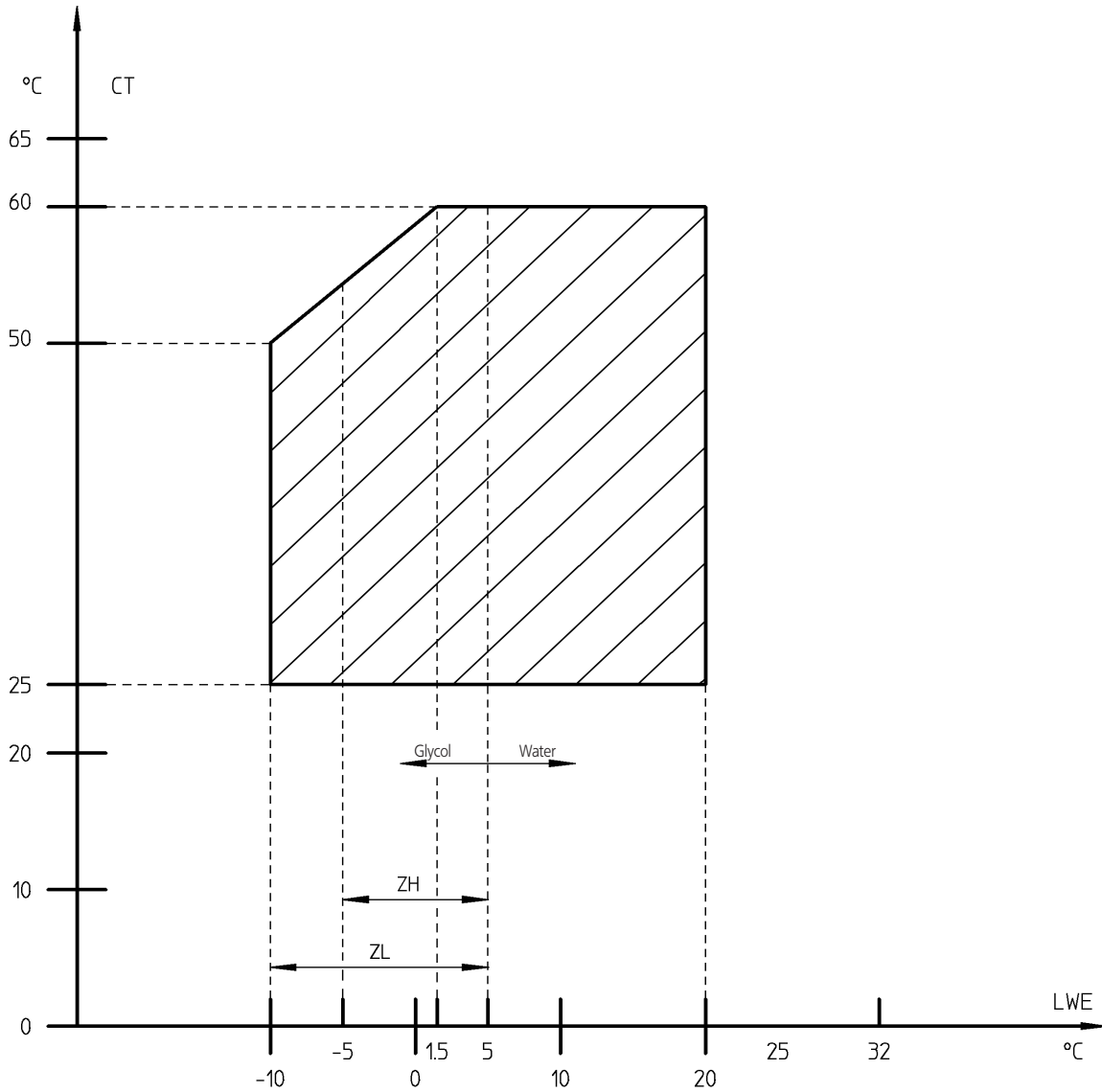

- \* LWE = Leaving Water Evaporator (°C)
- \* CT = Condensing Temperature (°C)

4TW57293-1

# 10 Operation range

## 10 - 1 Operation Range

EWLP040-065KBW1N

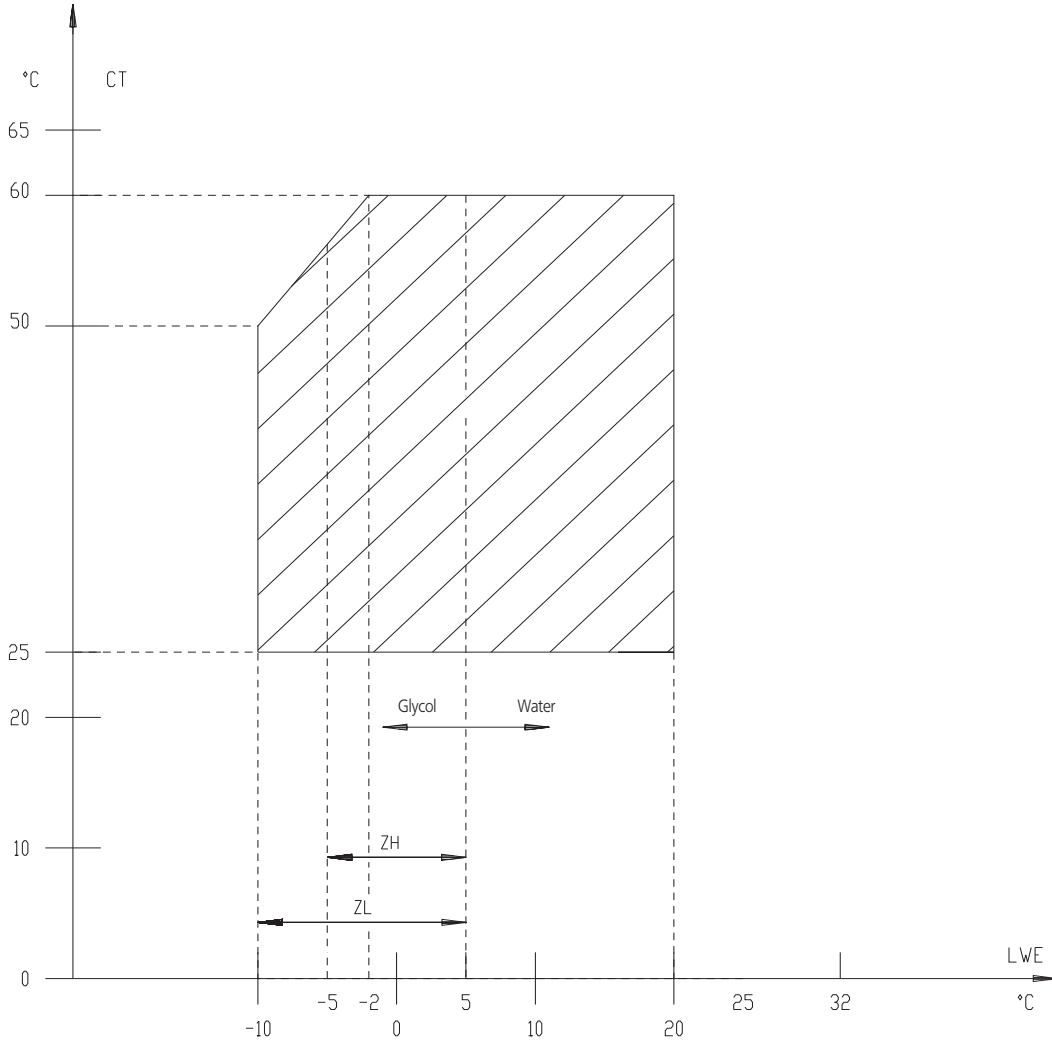

LWE = Leaving Water Evaporator (°C)  
 CT = Condensing temperature (°C)

4TW53473-2

# 11 Hydraulic performance

## 11 - 1 Water Pressure Drop Curve Evaporator

11

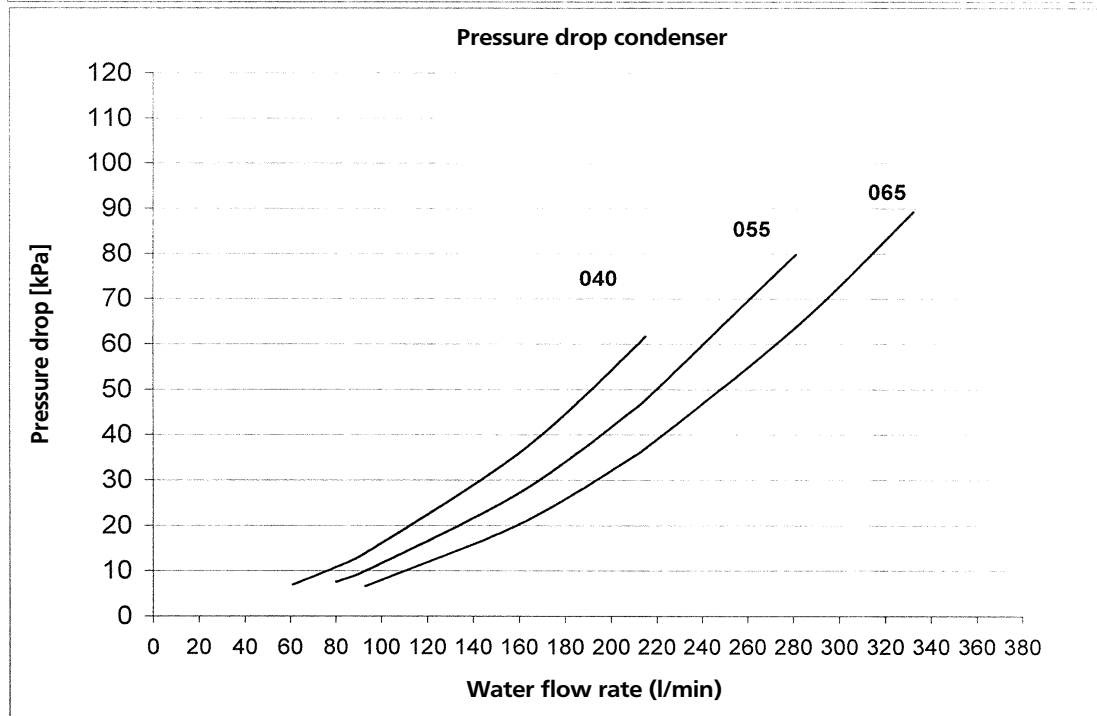
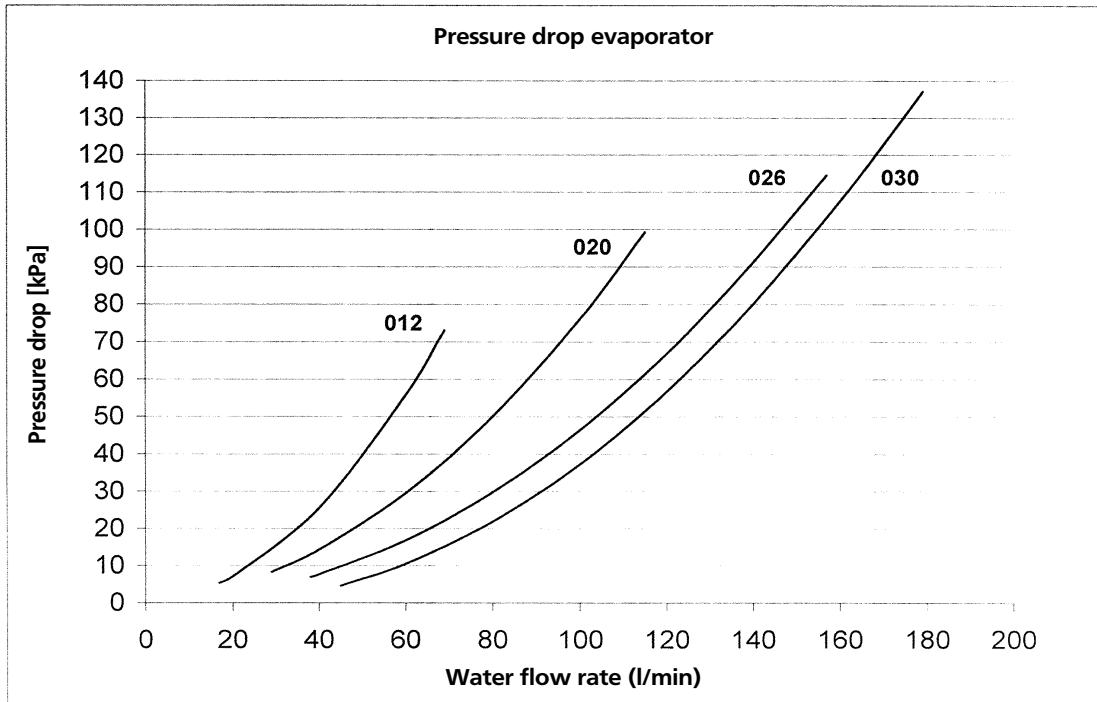

**Warning:** Selecting a flow outside the curves can cause damage to or malfunction of the unit. See also minimum and maximum allowed water flowrange in the technical specifications.

4TW57299-1A



In all of us,  
a green heart

Daikin's unique position as a manufacturer of air conditioning equipment, compressors and refrigerants has led to its close involvement in environmental issues. For several years Daikin has had the intention to become a leader in the provision of products that have limited impact on the environment. This challenge demands the eco design and development of a wide range of products and an energy management system, resulting in energy conservation and a reduction of waste.



Daikin Europe N.V. participates in the Eurovent Certification programme for Air conditioners (AC), Liquid Chilling Packages (LCP) and Fan coil units (FCU). Check on-going validity of certificate online: [www.eurovent-certification.com](http://www.eurovent-certification.com) or using: [www.certiflash.com](http://www.certiflash.com)

The present leaflet is drawn up by way of information only and does not constitute an offer binding upon Daikin Europe N.V.. Daikin Europe N.V. has compiled the content of this leaflet to the best of its knowledge. No express or implied warranty is given for the completeness, accuracy, reliability or fitness for particular purpose of its content and the products and services presented therein. Specifications are subject to change without prior notice. Daikin Europe N.V. explicitly rejects any liability for any direct or indirect damage, in the broadest sense, arising from or related to the use and/or interpretation of this leaflet. All content is copyrighted by Daikin Europe N.V.

BARCODE

Daikin products are distributed by: