



Air Conditioning Technical Data

Ceiling suspended unit



EEDEN13-204

FXHQ-A

TABLE OF CONTENTS

FXHQ-A

1	Features	2
2	Specifications	3
	Technical Specifications	3
	Electrical Specifications	4
3	Electrical data	5
	Electrical Data	5
4	Safety device settings	6
	Safety Device Settings	6
5	Options	7
	Options	7
6	Capacity tables	8
	Cooling Capacity Tables	8
	Heating Capacity Tables	9
	Capacity Correction Factor	10
7	Dimensional drawings	12
	Dimensional Drawings	12
	Dimensional Drawings with Accessories	14
8	Piping diagrams	15
	Piping Diagrams	15
9	Wiring diagrams	16
	Wiring Diagrams - Single Phase	16
10	Sound data	17
	Sound Pressure Spectrum	17

1 Features

- Ideal solution for commercial spaces with narrow or no false ceilings
- The unit can easily be mounted in corners and narrow spaces, as it only needs 30mm lateral service space
- User friendly remote control with contemporary design
- Low energy consumption thanks to DC fan motor and drain pump
- Easy to use: all main functions directly accessible
- Stylish unit blends easily with any interior, as the flaps close entirely when not in operation
- Easy setup: clear graphical user interface for advanced menu settings
- Can be installed in both new and existing buildings
- Optimise your air conditioning system by activating a series of energy saving functions (temperature range limit, setback function, off timer, ...)
- Wider air discharge thanks to Coanda effect: up to 100°
- Keep track of your energy consumption with the kWh indication showing an indicative electricity consumption
- Air flow distribution for ceiling heights up to 3.8m without capacity loss
- Set up to 3 independent schedules, so the user can easily change the schedule himself throughout the year (e.g. summer, winter, mid-season)
- Real time clock with auto update to daylight saving time
- Supports multiple languages (English, German, Dutch, Spanish, Italian, Portuguese, French, Greek, Russian, Turkish and Polish)
- Possibility to individually restrict menu functions
- When a power failure occurs all settings remain stored up to 48 hours thanks to the built-in backup power
- Home leave operation maintains the indoor temperature at your specified comfort level during absence, thus saving energy



3 steps



optional

2 Specifications

2-1 Technical Specifications				FXHQ32A	FXHQ63A	FXHQ100A	
Cooling capacity	Nom.		kW	3.6	7.1	11.2	
Heating capacity	Nom.		kW	4.0	8.0	12.5	
Power input - 50Hz	Cooling	Nom.	kW	0.107	0.111	0.237	
	Heating	Nom.	kW	0.107	0.111	0.237	
Casing	Colour			Fresh White			
	Material			Resin			
Dimensions	Unit	Height	mm	235			
		Width	mm	960	1,270	1,590	
		Depth	mm	690			
	Packed unit	Height	mm	340	349		
		Width	mm	1,116	1,426	1,746	
		Depth	mm	858	878		
Weight	Unit		kg	24	33	39	
	Packed unit		kg	38	55	62	
Heat exchanger	Type			Cross fin coil (multi louver fins and Hi-XSL tubes)			
	Length		mm	722	1,032	1,352	
	Rows	Quantity		2	3		
	Fin pitch		mm	1.5			
	Passes	Quantity		4	5	10	
	Face area		m ²	0.213	0.303	0.398	
	Stages	Quantity		14			
	Empty tubeplate hole	Quantity		0			
	Fan	Type			Sirocco fan		
Quantity			2	3	4		
Air flow rate - 50Hz		Cooling	High	m ³ /min	14.0	20.0	29.5
			Nom.	m ³ /min	12.0	17.0	24.0
			Low	m ³ /min	10.0	14.0	19.0
		Heating	High	m ³ /min	14.0	20.0	29.5
			Nom.	m ³ /min	12.0	17.0	24.0
			Low	m ³ /min	10.0	14.0	19.0
Fan motor		Model			2D15L1AA1	3D15L1AA1	4D15L1AC1
	Speed	Steps		3			
	Output	High	W	60	91	150	
Sound pressure level	Cooling	High	dBA	36.0	37.0	44.0	
		Nom.	dBA	34.0	35.0	37.0	
		Low	dBA	31.0	34.0		
	Heating	High	dBA	36.0	37.0	44.0	
		Nom.	dBA	34.0	35.0	37.0	
		Low	dBA	31.0	34.0		
Refrigerant	Type			R-410A			
Piping connections	Liquid	Type		Flare connection			
		OD	mm	6.35	9.52		
	Gas	Type		Flare connection			
		OD	mm	12.7	15.9		
	Drain	VP20 (I.D. 20/O.D. 26)					
Heat insulation	Heat resistant foamed polyethylene, regular foamed polyethylene						
Air filter	Type			Resin net with mold resistance			

Standard Accessories : Screw for wiring fixture;

Standard Accessories : Wiring fixture;

Standard Accessories : Resin bushing;

Standard Accessories : Installation pattern;

Standard Accessories : Sealing material;

Standard Accessories : Joint insulating material;

Standard Accessories : Clamps;

Standard Accessories : Washer for hanger bracket;

Standard Accessories : Clamp metal;

Standard Accessories : Drain hose;

2 Specifications

Standard Accessories : Declaration of conformity;

Standard Accessories : Installation manual;

Standard Accessories : Operation manual;

2

2-2 Electrical Specifications				FXHQ32A	FXHQ63A	FXHQ100A
Power supply	Name			VE		
	Phase			1~		
	Frequency	Hz		50		
	Voltage	V		220-240		
Voltage range	Min.	%		10		
	Max.	%		10		
Current - 50Hz	Minimum circuit amps (MCA)		A	0.8		1.7
	Maximum fuse amps (MFA)		A	16		
	Full load amps (FLA)	Fan motor	A	0.6		1.3

Notes

- (1) Voltage range: units are suitable for use on electrical systems where voltage supplied to unit terminal is not below or above listed range limits.
- (2) Maximum allowable voltage range variation between phases is 2%.
- (3) MCA/MFA: $MCA = 1.25 \times FLA$
- (4) $MFA \leq 4 \times FLA$
- (5) Next lower standard fuse rating minimum 16A
- (6) Select wire size based on the value of MCA
- (7) Instead of a fuse, use a circuit breaker

3 Electrical data

3 - 1 Electrical Data

FXHQ-A				Power supply		IFM		Input (W)	
Model	Units		Voltage range	MCA	MFA	kW	FLA	Cooling	Heating
	Hz	Volts							
FXHQ32A	50	220-240	Max. 264 Min. 198	0.8	16	0.060	0.6	107	107
FXHQ63A				0.8	16	0.091	0.6	111	111
FXHQ100A				1.7	16	0.150	1.3	237	237

Symbols:

MCA: Min. Circuit Amps. (A)
MFA: Max. Fuse Amps (A) (see note 5)
kW: Fan Motor Rated Output (kW)
FLA: Full Load Amps. (A)
IFM: Indoor Fan Motor.

NOTES

- 1 Voltage range:
Units are suitable for use on electrical systems where voltage supplied to unit terminal is not below or above listed range limits.
- 2 Maximum allowable voltage unbalance between phases is 2%.
- 3 MCA/MFA
 $MCA = 1.25 \times FLA$
 $MFA \leq 4 \times FLA$
(next lower standard fuse rating min. 16A)
- 4 Select a wire size based on the MCA.
- 5 Instead of fuse, use circuit breaker.

4D080219

4 Safety device settings

4 - 1 Safety Device Settings

FXHQ-A

Safety devices		32	63	100
FXHQ~A	Fuse	250V 3.15A	250V 3.15A	250V 3.15A
	Fan motor thermal fuse	°C	---	---
	Fan motor thermal protector	°C	---	---

3D080195

5 Options

5 - 1 Options

FXHQ-A				
Name of option	Remark	FXHQ-A		
		32	63	100
Long-life filter		KAFP501A56	KAFP501A80	KAFP501A160
Fresh air intake kit		KDDQ50A140		
L-type piping kit (for upward direction)		KHFP5N63	KHFP5N160	
Remote controller	Wired type	BRC1D52, BRC1E52A/B, BRC1D61 ✕ 1		
	Infrared type	Heat pump use	BRC7GA53	
		Cooling only use	BRC7GA56	
Central remote controller		DCS302C51, DCS302C61 ✕ 1		
Unified ON/OFF controller		DCS301B51, DSC301B61 ✕ 1		
Schedule timer		DST301B51, DST301B61 ✕ 1		
Residential remote control		DCS303A51 ✕ 1, ✕ 2		
Wiring adapter for electrical appendices		KRP1BA54		
Wiring adapter for electrical appendices		KRP4AA52		
Wiring adapter for electrical appendices		KRP2A62		
External adaptor for outdoor unit (installation on indoor unit)		DTA104A62		
Installation box for adapter PCB		KRP1D93A		
Remote sensor		KRCS01-4B		
Remote On/Off (Connector for forced on, forced off)		EKRORO4		
Noise filter (for electromagnetic use only)		KEK26-1		
Electrical box with earth terminal (3 blocks)		KJB311AA		
Electrical box with earth terminal (2 blocks)		KJB212AA		

Note)

✕ 1; for DAME only

✕ 2; For residential use only. Cannot be used together with other centralised control equipment.

3D080173

6 Capacity tables

6 - 1 Cooling Capacity Tables

FXHQ-A

Cooling Capacity

TC: Total capacity, kW
SHC: Sensible heat capacity, kW

Unit size	Indoor air temp.													
	14.0 °CWB		16.0 °CWB		18.0 °CWB		19.0 °CWB		20.0 °CWB		22.0 °CWB		24.0 °CWB	
	20 °CDB		23 °CDB		26 °CDB		27 °CDB		28 °CDB		30 °CDB		32 °CDB	
	TC	SHC	TC	SHC	TC	SHC	TC	SHC	TC	SHC	TC	SHC	TC	SHC
32	2.4	2.0	2.9	2.3	3.4	2.6	3.6	2.6	3.6	2.6	3.7	2.5	3.8	2.5
63	4.8	3.9	5.7	4.4	6.6	5.0	7.1	4.8	7.2	4.7	7.4	4.6	7.5	5.1
100	7.6	5.5	9.0	6.3	10.5	7.1	11.2	7.3	11.3	7.2	11.6	7.0	11.9	6.7

NOTES - OPMERKINGEN - REMARQUES - ANMERKUNGEN - NOTAS - NOTE - ΣΗΜΕΙΩΣΕΙΣ - NOTLAR - ПРИМЕЧАНИЯ

- This table is for the selection of indoor equipment.
 - Deze tabel is bedoeld voor het kiezen van de binnenunit.
 - Ce tableau concerne la sélection de l'équipement intérieur.
 - Diese Tabelle ist für die Auswahl der Innenanlagen.
 - Esta tabla es para seleccionar el equipo interior.
 - Usare questa tabella per la selezione delle apparecchiature interne.
 - Αυτός ο πίνακας προορίζεται για την επιλογή εσωτερικού εξοπλισμού.
 - Bu tablo iç ünite ekipmanlarının seçimine yöneliktir.
 - Эта таблица предназначена для выбора устанавливаемого в помещении оборудования.
- In the event that conditions differ due to the design requirements after system selection, actual operating ability of the indoor equipment will differ from that noted in the table because of changes in the outdoor air temperature and load factor.
 - Als nadat u het systeem hebt gekozen de voorwaarden afwijken van de ontwerpvereisten, dan zal het reële bedrijfsvermogen van de binnenunit afwijken van de in de tabel vermelde gegevens, wegens de afwijkende buitenluchttemperatuur en de belastingsfactor.
 - Si les exigences de conception après la sélection du système entraînent une modification des conditions, les capacités opérationnelles réelles de l'équipement intérieur diffèrent de celles indiquées dans le tableau en raison de la modification de la température de l'air extérieure et du facteur de charge.
 - Falls Bedingungen aufgrund der Konstruktionsanforderungen nach der Systemauswahl abweichen, dann weicht aufgrund der Änderungen der Außenlufttemperatur und des Lastfaktors die tatsächliche Betriebsfähigkeit der Innenanlage von der in der Tabelle aufgeführten ab.
 - En caso de que las condiciones difieran debido a los requisitos de diseño tras seleccionar el sistema, la capacidad de funcionamiento real del equipo interior diferirá de la que se muestra en la tabla debido a los cambios de la temperatura de aire exterior y al factor de carga.
 - Nel caso in cui intervenissero dei cambiamenti nelle condizioni dovuti a requisiti di progettazione successivi alla selezione del sistema, la capacità operativa effettiva delle apparecchiature interne sarà diversa da quella indicata in tabella a causa della diversa temperatura dell'aria esterna e del fattore di carico.
 - Στην περίπτωση που οι συνθήκες διαφέρουν λόγω των απαιτήσεων σχεδιασμού μετά την επιλογή συστήματος, η πραγματική δυνατότητα του εσωτερικού εξοπλισμού θα διαφέρει από την αναφερόμενη στον πίνακα, λόγω των αλλαγών στην εξωτερική θερμοκρασία αέρα και στο συντελεστή φορτίου.
 - Sistem seçiminin sonra tasarım gerekleri nedeniyle koşulların değişmesi durumunda, dış hava sıcaklığı ve yük faktöründeki değişiklikler nedeniyle iç ekipmanın gerçek çalışma kapasitesi tabloda belirtilenden farklı olacaktır.
 - В случае, если реальные условия отличаются от проектных условий работы, используемых при выборе системы, фактические характеристики устанавливаемого в помещении оборудования будут отличаться от указанных в таблице вследствие изменения температуры воздуха снаружи и показателя нагрузки.
- In this case, use the ability table for the indoor equipment selected and correct for the ratio of change in ability.
 - Gebruik in dat geval de vermogenstabel van de gekozen binneninstallatie en kies het juiste vermogen.
 - Le cas échéant, utiliser le tableau de capacité de l'équipement intérieur sélectionner et corriger le rapport de modification de capacité.
 - Verwenden Sie in diesem Fall die Fähigkeit für die ausgewählte Innenanlage und korrigieren Sie das Verhältnis der Änderung in der Fähigkeit.
 - En este caso, utilice la tabla de capacidades del equipo interior seleccionado y corrija la relación de cambio en capacidad.
 - In questo caso, usare la tabella delle capacità per le apparecchiature interne selezionate ed apportare le modifiche del caso in base alla percentuale di cambiamento di capacità.
 - Σε αυτή την περίπτωση χρησιμοποιήστε τον πίνακα δυνατοτήτων για τον επιλεγμένο εσωτερικό εξοπλισμό και διορθώστε για την αναλογία αλλαγής στη δυνατότητα.
 - Bu durumda, seçilen iç ekipman için kapasite tablosunu kullanın ve kapasitedeki değişim oranına göre düzeltme yapın.
 - В этом случае используйте таблицу характеристик выбранного устанавливаемого в помещении оборудования и внесите необходимую поправку на их изменение.

6 Capacity tables

6 - 2 Heating Capacity Tables

FXHQ-A

Heating Capacity

Unit size	Indoor air temp. °CDB					
	16.0	18.0	20.0	21.0	22.0	24.0
	kW	kW	kW	kW	kW	kW
32	4.2	4.2	4.0	3.9	3.7	3.5
63	8.4	8.4	8.0	7.7	7.5	7.0
100	13.1	13.1	12.5	12.1	11.7	10.9

NOTES - OPMERKINGEN - REMARQUES - ANMERKUNGEN - NOTAS - NOTE - ΣΗΜΕΙΩΣΕΙΣ - NOTLAR - ПРИМЕЧАНИЯ

- This table is for the selection of indoor equipment.
 - Deze tabel is bedoeld voor het kiezen van de binnenunit.
 - Ce tableau concerne la sélection de l'équipement intérieur.
 - Diese Tabelle ist für die Auswahl der Innenanlagen.
 - Esta tabla es para seleccionar el equipo interior.
 - Usare questa tabella per la selezione delle apparecchiature interne.
 - Αυτός ο πίνακας προορίζεται για την επιλογή εσωτερικού εξοπλισμού.
 - Bu tablo iç ünite ekipmanlarının seçimine yöneliktir.
 - Эта таблица предназначена для выбора устанавливаемого в помещении оборудования.
- In the event that conditions differ due to the design requirements after system selection, actual operating ability of the indoor equipment will differ from that noted in the table because of changes in the outdoor air temperature and load factor.
 - Als nadat u het systeem hebt gekozen de voorwaarden afwijken van de ontwerpvereisten, dan zal het reële bedrijfsvermogen van de binnenunit afwijken van de in de tabel vermelde gegevens, wegens de afwijkende buitenluchttemperatuur en de belastingsfactor.
 - Si les exigences de conception après la sélection du système entraînent une modification des conditions, les capacités opérationnelles réelles de l'équipement intérieur diffèrent de celles indiquées dans le tableau en raison de la modification de la température de l'air extérieure et du facteur de charge.
 - Falls Bedingungen aufgrund der Konstruktionsanforderungen nach der Systemauswahl abweichen, dann weicht aufgrund der Änderungen der Außenlufttemperatur und des Lastfaktors die tatsächliche Betriebsfähigkeit der Innenanlage von der in der Tabelle aufgeführten ab.
 - En caso de que las condiciones difieran debido a los requisitos de diseño tras seleccionar el sistema, la capacidad de funcionamiento real del equipo interior diferirá de la que se muestra en la tabla debido a los cambios de la temperatura de aire exterior y al factor de carga.
 - Nel caso in cui intervenissero dei cambiamenti nelle condizioni dovuti a requisiti di progettazione successivi alla selezione del sistema, la capacità operativa effettiva delle apparecchiature interne sarà diversa da quella indicata in tabella a causa della diversa temperatura dell'aria esterna e del fattore di carico.
 - Στην περίπτωση που οι συνθήκες διαφέρουν λόγω των απαιτήσεων σχεδιασμού μετά την επιλογή συστήματος, η πραγματική δυνατότητα του εσωτερικού εξοπλισμού θα διαφέρει από την αναφερόμενη στον πίνακα, λόγω των αλλαγών στην εξωτερική θερμοκρασία αέρα και στο συντελεστή φορτίου.
 - Sistem seçiminin sonra tasarım gerekleri nedeniyle koşulların değişmesi durumunda, dış hava sıcaklığı ve yük faktöründeki değişiklikler nedeniyle iç ekipmanın gerçek çalışma kapasitesi tablodaki belirtilenden farklı olacaktır.
 - В случае, если реальные условия отличаются от проектных условий работы, используемых при выборе системы, фактические характеристики устанавливаемого в помещении оборудования будут отличаться от указанных в таблице вследствие изменения температуры воздуха снаружи и показателя нагрузки.
- In this case, use the ability table for the indoor equipment selected and correct for the ratio of change in ability.
 - Gebruik in dat geval de vermogenstabel van de gekozen binneninstallatie en kies het juiste vermogen.
 - Le cas échéant, utiliser le tableau de capacité de l'équipement intérieur sélectionné et corriger le rapport de modification de capacité.
 - Verwenden Sie in diesem Fall die Fähigkeit für die ausgewählte Innenanlage und korrigieren Sie das Verhältnis der Änderung in der Fähigkeit.
 - En este caso, utilice la tabla de capacidades del equipo interior seleccionado y corrija la relación de cambio en capacidad.
 - In questo caso, usare la tabella delle capacità per le apparecchiature interne selezionate ed apportare le modifiche del caso in base alla percentuale di cambiamento di capacità.
 - Σε αυτή την περίπτωση χρησιμοποιήστε τον πίνακα δυνατοτήτων για τον επιλεγμένο εσωτερικό εξοπλισμό και διορθώστε για την αναλογία αλλαγής στη δυνατότητα.
 - Bu durumda, seçilen iç ekipman için kapasite tablosunu kullanın ve kapasitedeki değişim oranına göre düzeltilme yapın.
 - В этом случае используйте таблицу характеристик выбранного устанавливаемого в помещении оборудования и внесите необходимую поправку на их изменение.

6 Capacity tables

6 - 3 Capacity Correction Factor

FXHQ-A

		Capacity correction factor Te = 9°C						
		14.0 °CWB 20.0 °CDB	16.0 °CWB 23.0 °CDB	18.0 °CWB 26.0 °CDB	19.0 °CWB 27.0 °CDB	20.0 °CWB 28.0 °CDB	22.0 °CWB 30.0 °CDB	24.0 °CWB 32.0 °CDB
FXHQ32	Indoor air temperature							
	TC	0.707	0.692	0.745	0.768	0.788	0.819	0.844
FXHQ63	SHF	1.098	1.181	1.127	1.102	1.082	1.055	1.042
	TC	0.695	0.702	0.749	0.772	0.791	0.821	0.844
FXHQ100	SHF	1.120	1.169	1.122	1.098	1.079	1.058	1.060
	TC	0.690	0.697	0.757	0.779	0.798	0.829	0.856
	SHF	1.123	1.169	1.114	1.091	1.073	1.055	1.057

3D079901

NOTES - ANMERKUNGEN - Σημειώσεις - NOTAS - REMARQUES - NOTE - OPMERKINGEN - Примечания - NOTLAR

How to use this table - So verwenden Sie diese Tabelle - Πώς θα χρησιμοποιήσετε αυτό τον πίνακα - Cómo utilizar esta tabla - Utilisation de ce tableau - Come utilizzare questa tabella - Gebruik van deze tabel - Как пользоваться этой таблицей - Bu tablo nasıl kullanılır?:

1. Capacity : Total capacity for High sensible mode = Total capacity for normal capacity table X TC ratio.

Leistung: Gesamtleistung für hochfühlbaren Leistungsmodus = Gesamtleistung für normale Leistungstabelle x GL-Verhältnis.

Απόδοση: Συνολική απόδοση για τη λειτουργία υψηλής ευαισθησίας = Συνολική απόδοση για τον πίνακα κανονικών αποδόσεων X αναλογία TC

Capacidad: Capacidad total para el modo de alta sensibilidad = Capacidad total para la tabla de capacidad normal X relación TC.

Capacité sensible (FCS (Facteur de chaleur sensible) – en anglais : SHF) : FCS pour le mode sensibilité élevée (« High ») = FCS du tableau des capacités normales x rapport FCS.

Capacità: Capacità totale per modalità ad alta capacità sensibile = Capacità totale per tabella capacità normali X rapporto TC.

Capaciteit: totale capaciteit in modus grote ("High") gevoeligheid = totale capaciteit uit de tabel met normale capaciteiten x TC-ratio.

Производительность: Общая производительность для режима с высоким коэфф. ошутимого охлаждения = Общая производительность для нормального режима, таблица X коэфф. TC.

Kapasite: Yüksek algı modu için toplam kapasite = Normal kapasite tablosundaki toplam kapasite değeri x TC oranı.

2. Sensible capacity (SHF): SHF for High sensible mode = SHF for normal capacity table X SHF ratio .

Fühlbare Leistung (SHF): SHF für hochfühlbaren Leistungsmodus = SHF für normale Leistungstabelle x SHF-Verhältnis.

Αισθητή απόδοση (SHF): SHF για λειτουργία υψηλής ευαισθησίας = SHF για πίνακα κανονικών αποδόσεων X αναλογία SHF .

Capacidad sensible (FCS): SHF para el modo de alta sensibilidad = SHF para la tabla de capacidad normal X relación SHF.

Capacité sensible (FCS (Facteur de chaleur sensible) – en anglais : SHF) : FCS pour le mode sensibilité élevée (« High ») = FCS du tableau des capacités normales x rapport FCS.

Capacità sensibile (SHF): SHF per modalità ad alta capacità sensibile = SHF per tabella capacità normali X rapporto SHF.

Gevoeligheidscapaciteit (WGF (warmtegevoelsfactor)– in het Engels "SHF"): WGF voor de modus grote ("High") gevoeligheid = WGF uit de tabel met normale capaciteiten x WGF-ratio.

Ощутимая производительность (SHF): SHF для режима с высоким коэфф. ошутимого охлаждения = SHF для нормального режима, таблица X коэфф. SHF.

Algılanabilir kapasite (SHF): Yüksek algı modu için SHF = Normal kapasite tablosundaki SHF değeri x SHF oranı.

3. In case of SHF is bigger than 1 , SHF is "1"

Für den Fall, dass SHF größer als 1 ist, wird SHF als "1" angenommen.

Σε περίπτωση που το SHF είναι μεγαλύτερο από 1, το SHF είναι "1"

En caso de que SHF sea superior a 1 , SHF equivale a "1"

Si FCS est supérieur à 1, utilisez « 1 » pour FCS.

Qualora il valore SHF sia maggiore di 1 , SHF è "1"

Indien WGF groter is dan 1, neem dan "1" voor WGF.

Если SHF больше 1, то SHF равен "1"

SHF değeri 1'den büyükse, SHF değeri "1" kabul edilmelidir

6 Capacity tables

6 - 3 Capacity Correction Factor

FXHQ-A

		Capacity correction factor for Te = 11°C						
		20°CDB	23°CDB	26°CDB	27°CDB	28°CDB	30°CDB	32°CDB
		14°CWB	16°CWB	18°CWB	19°CWB	20°CWB	22°CWB	24°CWB
32	TC ratio	0,564	0,579	0,578	0,607	0,640	0,693	0,734
	SHF ratio	1,098	1,192	1,277	1,231	1,183	1,118	1,085
63	TC ratio	0,556	0,576	0,584	0,614	0,645	0,697	0,734
	SHF ratio	1,120	1,209	1,270	1,219	1,174	1,119	1,104
100	TC ratio	0,554	0,568	0,586	0,623	0,655	0,708	0,751
	SHF ratio	1,123	1,213	1,262	1,205	1,162	1,112	1,097

3D079901

NOTES - ANMERKUNGEN - Σημειώσεις - NOTAS - REMARQUES - NOTE - OPMERKINGEN - Примечания - NOTLAR

How to use this table - So verwenden Sie diese Tabelle - Πώς θα χρησιμοποιήσετε αυτό τον πίνακα - Cómo utilizar esta tabla - Utilisation de ce tableau - Come utilizzare questa tabella - Gebruik van deze tabel - Как пользоваться этой таблицей - Bu tablo nasıl kullanılmalı?:

1. Capacity : Total capacity for High sensible mode = Total capacity for normal capacity table X TC ratio.

Leistung: Gesamtleistung für hochfühlbaren Leistungsmodus = Gesamtleistung für normale Leistungstabelle x GL-Verhältnis.

Απόδοση: Συνολική απόδοση για τη λειτουργία υψηλής ευαισθησίας = Συνολική απόδοση για τον πίνακα κανονικών αποδόσεων X αναλογία TC

Capacidad: Capacidad total para el modo de alta sensibilidad = Capacidad total para la tabla de capacidad normal X relación TC.

Capacité sensible (FCS (Facteur de chaleur sensible) – en anglais : SHF) : FCS pour le mode sensibilité élevée (« High ») = FCS du tableau des capacités normales x rapport FCS.

Capacità: Capacità totale per modalità ad alta capacità sensibile = Capacità totale per tabella capacità normali X rapporto TC.

Capaciteit: totale capaciteit in modus grote ("High") gevoeligheid = totale capaciteit uit de tabel met normale capaciteiten x TC-ratio.

Производительность: Общая производительность для режима с высоким коэфф. ошутимого охлаждения = Общая производительность для нормального режима, таблица X коэфф. TC.

Kapasite: Yüksek algı modu için toplam kapasite = Normal kapasite tablosundaki toplam kapasite değeri x TC oranı.

2. Sensible capacity (SHF): SHF for High sensible mode = SHF for normal capacity table X SHF ratio .

Fühlbare Leistung (SHF): SHF für hochfühlbaren Leistungsmodus = SHF für normale Leistungstabelle x SHF-Verhältnis.

Αισθητή απόδοση (SHF): SHF για λειτουργία υψηλής ευαισθησίας = SHF για πίνακα κανονικών αποδόσεων X αναλογία SHF .

Capacidad sensible (FCS): SHF para el modo de alta sensibilidad = SHF para la tabla de capacidad normal X relación SHF.

Capacité sensible (FCS (Facteur de chaleur sensible) – en anglais : SHF) : FCS pour le mode sensibilité élevée (« High ») = FCS du tableau des capacités normales x rapport FCS.

Capacità sensibile (SHF): SHF per modalità ad alta capacità sensibile = SHF per tabella capacità normali X rapporto SHF.

Gevoeligheidscapaciteit (WGF (warmtegevoelsfactor)– in het Engels "SHF"): WGF voor de modus grote ("High") gevoeligheid = WGF uit de tabel met normale capaciteiten x WGF-ratio.

Ошутимая производительность (SHF): SHF для режима с высоким коэфф. ошутимого охлаждения = SHF для нормального режима, таблица X коэфф. SHF.

Algılanabilir kapasite (SHF): Yüksek algı modu için SHF = Normal kapasite tablosundaki SHF değeri x SHF oranı.

3. In case of SHF is bigger than 1 , SHF is "1"

Für den Fall, dass SHF größer als 1 ist, wird SHF als "1" angenommen.

Σε περίπτωση που το SHF είναι μεγαλύτερο από 1 , το SHF είναι "1"

En caso de que SHF sea superior a 1 , SHF equivale a "1"

Si FCS est supérieur à 1 , utilisez « 1 » pour FCS.

Qualora il valore SHF sia maggiore di 1 , SHF è "1"

Indien WGF groter is dan 1 , neem dan "1" voor WGF.

Если SHF больше 1 , то SHF равен "1"

SHF değeri 1'den büyükse, SHF değeri "1" kabul edilmelidir

7 Dimensional drawings

7 - 1 Dimensional Drawings

7

FXHQ32A

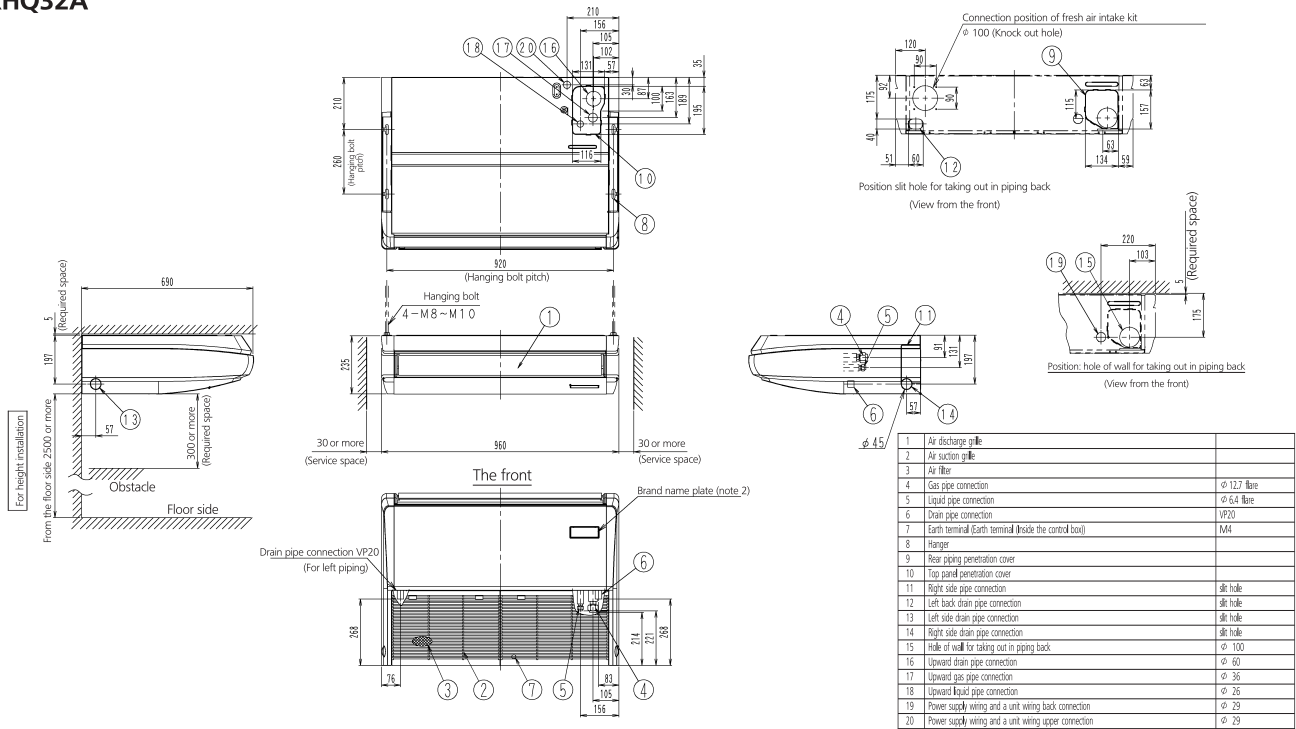

Note:

1. Location of unit's name plate: bottom of fan housing inside the suction grille.
2. In case of using infrared remote controller, this position will be a signal receiver. Refer to the drawing of infrared remote controller in detail.
3. Please do not place the thing been damp and troubled under an indoor unit. When the case where humidity is 80% or more, and the drain outlet are choked up and the air filter are dirty, dew may fall

3D080029

FXHQ63A

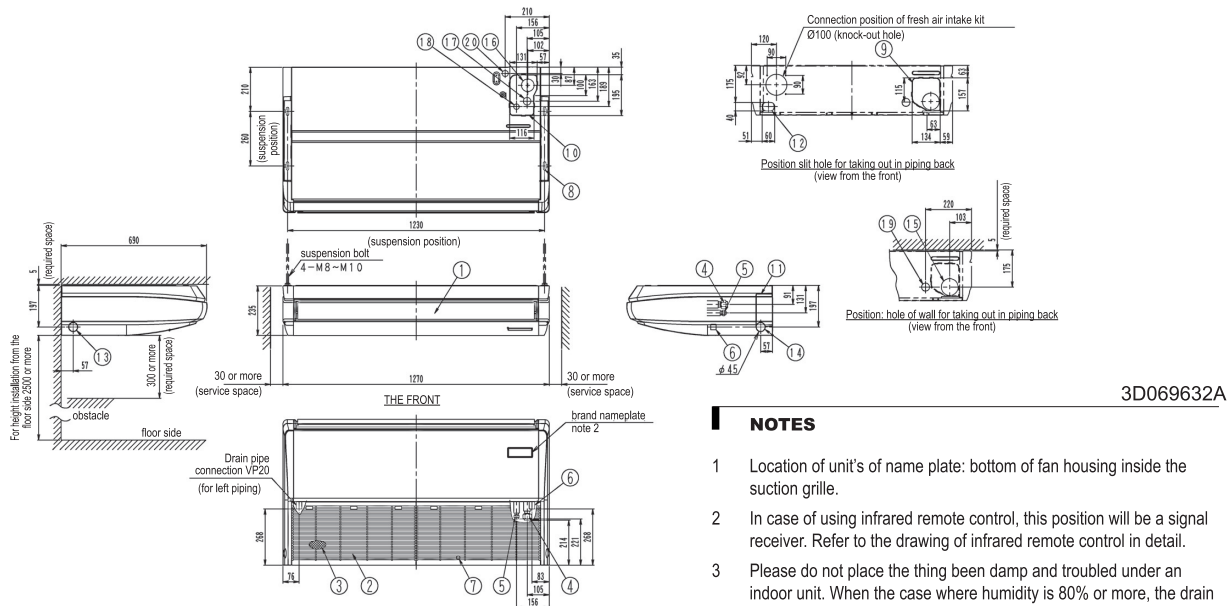

3D069632A

NOTES

1. Location of unit's of name plate: bottom of fan housing inside the suction grille.
2. In case of using infrared remote control, this position will be a signal receiver. Refer to the drawing of infrared remote control in detail.
3. Please do not place the thing been damp and troubled under an indoor unit. When the case where humidity is 80% or more, the drain outlet are choked up and the air filter are dirty, dew may fall.

Nr	Name	Description
1	Air discharge grille	
2	Air suction grille	
3	Air filter	
4	Gas pipe connection	∅15.9 flare
5	Liquid pipe connection	∅9.5 flare
6	Drain pipe connection	VP20
7	Earth terminal (inside electric components box)	M4
8	Hanger bracket	
9	Backward piping and wiring connection opening lid	
10	Upward piping and wiring connection opening lid	

11	Right side pipe connection	slit hole
12	Left back drain pipe connection	slit hole
13	Left side drain pipe connection	slit hole
14	Right side drain pipe connection	slit hole
15	Hole of wall for taking out in piping back	∅100
16	Upward drain pipe connection	∅60
17	Upward gas pipe connection	∅36
18	Upward liquid pipe connection	∅26
19	Power source wiring and a unit wiring back connection	∅29
20	Power source wiring and a unit wiring upper connection	∅29

7 Dimensional drawings

7 - 1 Dimensional Drawings

FXHQ100A

3D069633A

NOTES

- Location of unit's name plate: bottom of fan housing inside the suction grille.
- In case of using infrared remote control, this position will be a signal receiver. Refer to the drawing of infrared remote control in detail.
- Don't put anything under indoor unit because dew may fall by reason of following:
 - The humidity is 80% or more.
 - The drain outlet is stopped up.
 - The air filter is dirty.

Nr	Name	Description
1	Air discharge grille	
2	Air suction grille	
3	Air filter	
4	Gas pipe connection	Ø15.9 flare
5	Liquid pipe connection	Ø9.5 flare
6	Drain pipe connection	VP20
7	Earth terminal (inside electric components box)	M4
8	Hanger bracket	
9	Backward piping and wiring connection opening lid	
10	Upward piping and wiring connection opening lid	

11	Right side pipe connection	slit hole
12	Left back drain pipe connection	slit hole
13	Left side drain pipe connection	slit hole
14	Right side drain pipe connection	slit hole
15	Hole of wall for taking out in piping back	Ø100
16	Upward drain pipe connection	Ø60
17	Upward gas pipe connection	Ø36
18	Upward liquid pipe connection	Ø26
19	Power source wiring and a unit wiring back connection	Ø29
20	Power source wiring and a unit wiring upper connection	Ø29

7 Dimensional drawings

7 - 2 Dimensional Drawings with Accessories

7

FXHQ-A

Remote controller dimensions

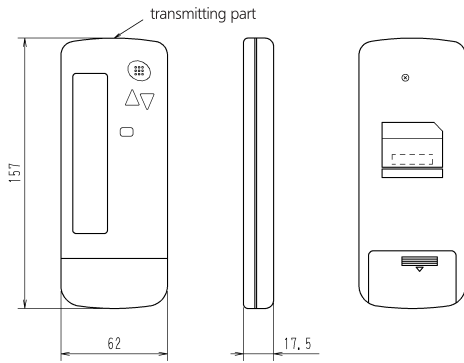

Receiver installation procedure

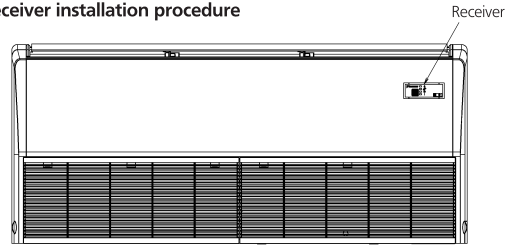

**Remote controller holder
Installation procedure**

(Installation to wall surface)

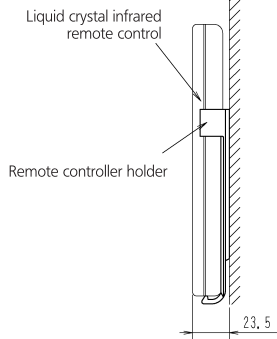

Receiver detail

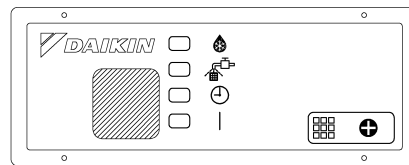

3D079916

8 Piping diagrams

8 - 1 Piping Diagrams

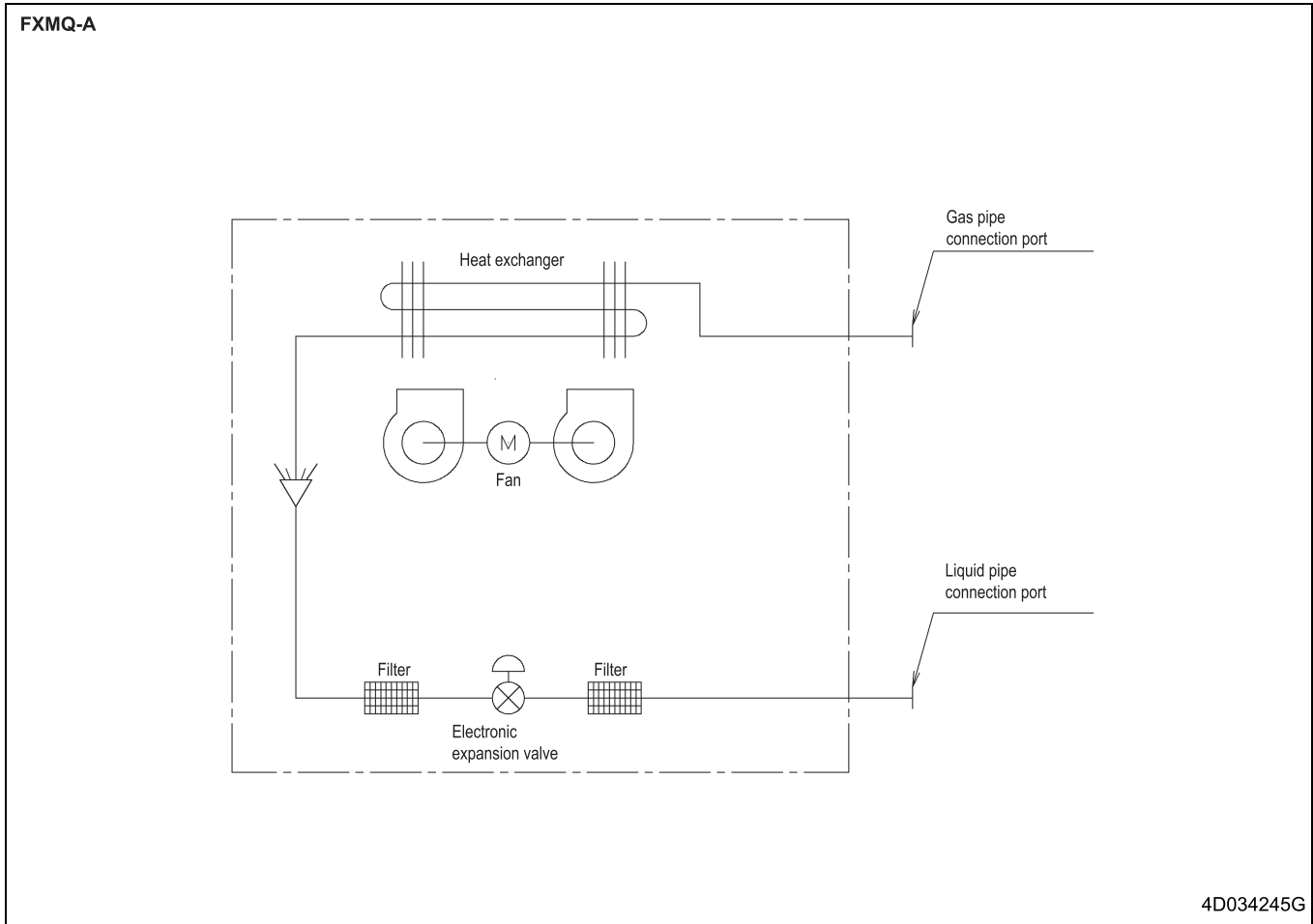

10 Sound data

10 - 1 Sound Pressure Spectrum

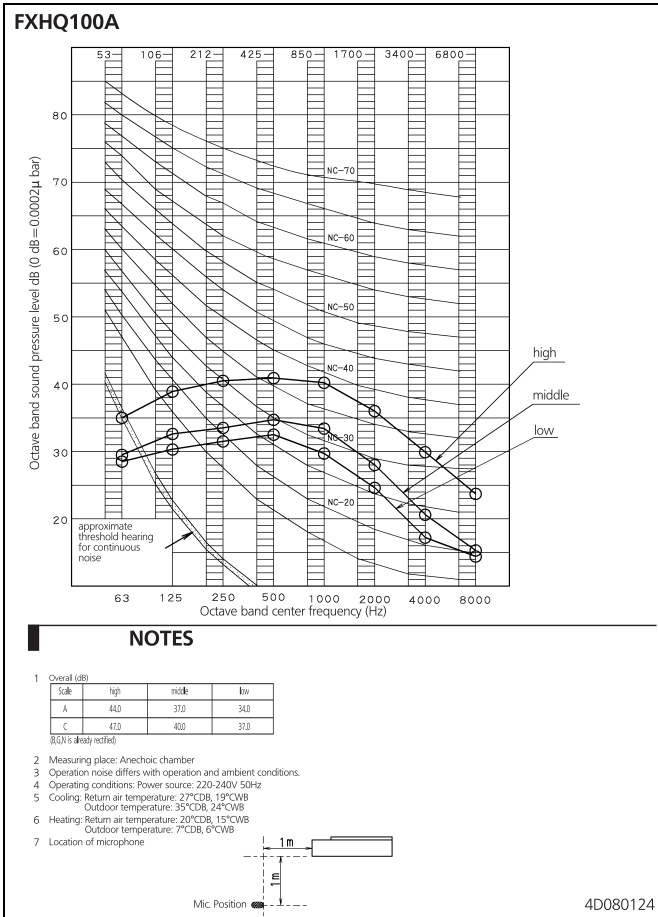
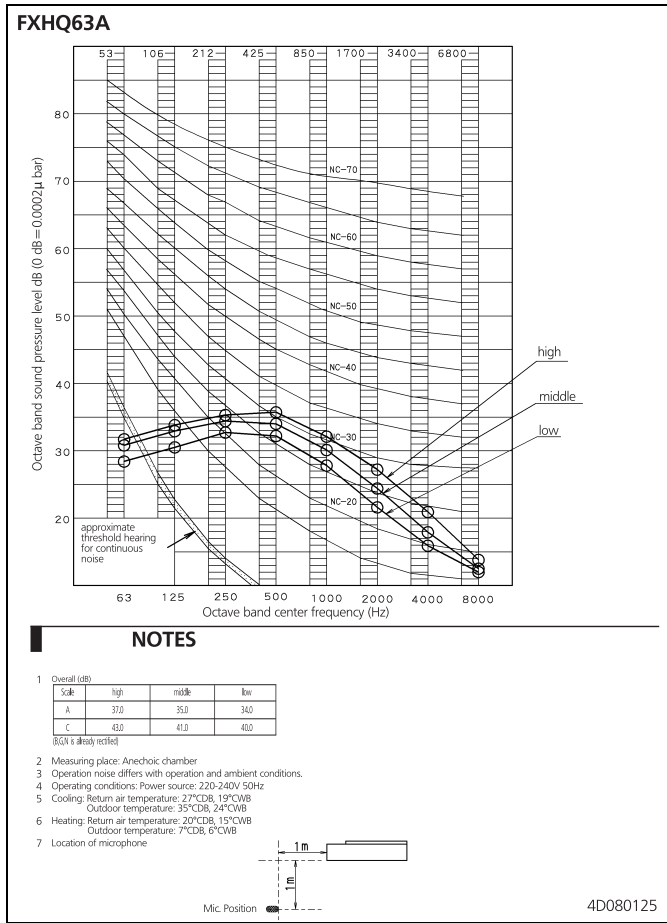
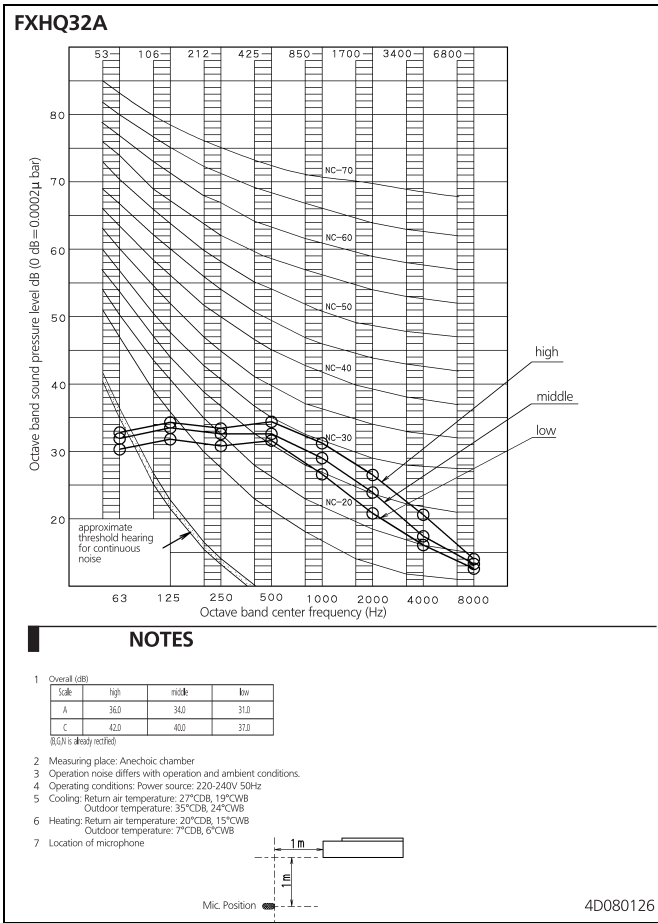



Daikin's unique position as a manufacturer of air conditioning equipment, compressors and refrigerants has led to its close involvement in environmental issues. For several years Daikin has had the intention to become a leader in the provision of products that have limited impact on the environment. This challenge demands the eco design and development of a wide range of products and an energy management system, resulting in energy conservation and a reduction of waste.



These products are not within the scope of the Eurovent certification program

The present leaflet is drawn up by way of information only and does not constitute an offer binding upon Daikin Europe N.V.. Daikin Europe N.V. has compiled the content of this leaflet to the best of its knowledge. No express or implied warranty is given for the completeness, accuracy, reliability or fitness for particular purpose of its content and the products and services presented therein. Specifications are subject to change without prior notice. Daikin Europe N.V. explicitly rejects any liability for any direct or indirect damage, in the broadest sense, arising from or related to the use and/or interpretation of this leaflet. All content is copyrighted by Daikin Europe N.V.

BARCODE

Daikin products are distributed by: