



Air Conditioners

Technical Data



VRV®III-S heat pump



EEDEN12-200

RXYSQ-P8Y1



Air Conditioners

Technical Data



VRV®III-S heat pump



EEDEN12-200

RXYSQ-P8Y1

TABLE OF CONTENTS

RXYSQ-P8Y1

1	Specifications	2
	Technical Specifications	2
	Electrical Specifications	4
2	Options	5
	Options	5
3	Capacity tables	6
	Cooling Capacity Tables	6
	Heating Capacity Tables	12
	Integrated Heating Capacity Correction Factor	18
	Capacity Correction Factor	19
4	Dimensional drawings	22
	Dimensional Drawings	22
5	Centre of gravity	23
	Centre of Gravity	23
6	Piping diagrams	24
	Piping Diagrams	24
7	Wiring diagrams	25
	Wiring Diagrams - Single Phase	25
8	External connection diagrams	26
	External Connection Diagrams	26
9	Sound data	27
	Sound Power Spectrum	27
	Sound Pressure Spectrum	28
10	Installation	30
	Service Space	30
	Refrigerant Pipe Selection	31
11	Operation range	33
	Operation Range	33

1 Specifications

1

1-1 Technical Specifications				RXYSQ4P8Y1	RXYSQ5P8Y1	RXYSQ6P8Y1	
Capacity range		HP		4	5	6	
Cooling capacity	Nom.	kW		11.2 (1)	14.0 (1)	15.5 (1)	
Heating capacity	Nom.	kW		12.5 (2)	16.0 (2)	18.0 (2)	
Capacity control	Method			Inverter controlled			
	Steps		%	24 ~ 100			
Power input - 50Hz	Cooling	Nom.	kW	2.89	3.61	4.66	
	Heating	Nom.	kW	2.82	3.97	4.70	
EER				3.88		3.33	
COP				4.43	4.03	3.83	
Maximum number of connectable indoor units				8 (6) / 8 (7)	10 (6) / 9 (7)	12 (6) / 9 (7)	
Indoor index connection	Min.			50	62.5	70	
	Nom.			-			
	Max.			130	162.5	182	
Casing	Colour			Daikin White			
	Material			Painted galvanized steel plate			
Dimensions	Unit	Height	mm	1,345			
		Width	mm	900			
		Depth	mm	320			
	Packed unit	Height	mm	1,524			
		Width	mm	980			
		Depth	mm	420			
Weight	Unit		kg	120			
	Packed unit		kg	130			
Packing	Material			Carton / Wood / EPS	Carton / Wood / EPS	Carton / Wood / EPS	
	Weight		kg	8			
Heat exchanger	Length		mm	857			
	Rows	Quantity		2			
	Fin pitch		mm	2			
	Passes	Quantity		10			
	Face area		m ²	1.131			
	Stages	Quantity		60			
	Empty tubeplate hole	Quantity		0			
	Tube type			ø8 Hi-XSS			
	Fin	Type		Non-symmetric waffle louver			
		Treatment		Corrosion resistant			
Fan	Type			Propeller fan			
	Quantity			2			
	Air flow rate	Cooling	Nom.	m ³ /min	106		
		Heating	Nom.	m ³ /min	102	105	
	External static pressure	Max.		Pa	78		
Discharge direction			Horizontal				
Fan motor	Quantity			2			
	Model			Brushless DC motor			
	Speed	Cooling	Nom.	rpm	850		
		Heating	Nom.	rpm	820	840	
	Drive			Direct drive			
Output		W		70			
Fan motor 2	Model			Brushless DC motor			
	Speed	Cooling	Nom.	rpm	815		
		Heating	Nom.	rpm	785	805	
	Drive			Direct drive			
	Output		W		70		
Sound power level	Cooling	Nom.	dBA	66	67	69	
Sound pressure level	Cooling	Nom.	dBA	50	51	53	
	Heating	Nom.	dBA	52	53	55	

2

1 Specifications

1-1 Technical Specifications				RXYSQ4P8Y1	RXYSQ5P8Y1	RXYSQ6P8Y1	
Compressor	Quantity			1			
	Model			JT1G-VDLR			
	Type			Hermetically sealed scroll compressor			
	Speed	rpm		6,480			
	Output	W		2,500	3,000	3,500	
	Starting method			Direct on line			
	Crankcase heater			W 33			
Operation range	Cooling	Min.~Max.	°CDB	-5~46			
	Heating	Min.~Max.	°CWB	-20~15.5			
Refrigerant	Type			R-410A			
	Charge			kg 4.0			
	Control			Expansion valve			
	Circuits	Quantity		1			
Refrigerant oil	Type			Daphne FVC68D			
	Charged volume			l 1.5			
Piping connections	Liquid	Type		Flare connection			
		OD	mm	9.52			
	Gas	Type		Flare connection (VRV®) / Braze connection (RA)	Flare connection (VRV®) / Braze connection (RA)	Braze connection	
		OD	mm	15.9 (6) / 19.1 (7)	15.9 (6) / 19.1 (7)	19.1	
	Drain	Quantity		3			
		OD	mm	26x3			
	Heat insulation			Both liquid and gas pipes			
	Piping length	OU - BP	Total	m	55 (7)		
			BP - IU	Max.	m 15 (7)		
			Total	m	60 (7)	80 (7)	90 (7)
Total piping length	System	Actual	m	300 (6) / 115 (7)	300 (6) / 135 (7)	300 (6) / 145 (7)	
Level difference	OU - IU	Outdoor unit in highest position	m	-			
		Indoor unit in highest position	m	-			
Defrost method				Reversed cycle			
Defrost control				Sensor for outdoor heat exchanger temperature			
Safety devices	Item	01	HPS				
		02	Fan motor thermal protection				
		03	Inverter overload protector				
		04	PC board fuse				
PED	Category			Category I			

Standard Accessories : Connection pipes; Quantity : 3;

Standard Accessories : Operation manual; Quantity : 1;

Standard Accessories : Installation manual; Quantity : 1;

1 Specifications

1

1-2 Electrical Specifications				RXYSQ4P8Y1	RXYSQ5P8Y1	RXYSQ6P8Y1
Power supply	Name			Y1		
	Phase			3N~		
	Frequency	Hz		50		
	Voltage		V	380-415		
Voltage range	Min.	%		-10		
	Max.	%		10		
Current	Nominal running current (RLA) - 50Hz	Cooling	A	5.30	6.77	7.79
Current - 50Hz	Maximum running current		A	13.5		
	Starting current (MSC)		A	5.30	6.77	7.79
	Zmax	List		No requirements		
	Minimum circuit amps (MCA)		A	13.5		
	Maximum fuse amps (MFA)		A	16.0		
	Full load amps (FLA)	Fan motor		A	0.3	
Fan motor 2		A	0.3			
Wiring connections - 50Hz	For power supply	Quantity		5		
		Remark		Earth wire included		
	For connection with indoor	Quantity		2		
		Remark		F1,F2		
Power supply intake				Both indoor and outdoor unit		
Field earth leakage breaker		mA		300		

Notes

- (1) Cooling: indoor temp. 27°CDB, 19.0°CWB; outdoor temp. 35°CDB; equivalent piping length: 5m; level difference: 0m
- (2) Heating: indoor temp. 20°CDB; outdoor temp. 7°CDB, 6°CWB; equivalent refrigerant piping: 5m; level difference: 0m
- (3) Sound power level is an absolute value that a sound source generates.
- (4) Sound pressure level is a relative value, depending on the distance and acoustic environment. For more details, please refer to the sound level drawings.
- (5) Sound values are measured in a semi-anechoic room.
- (6) In case VRV® indoor units are connected
- (7) In case RA indoors are connected
- (8) RLA is based on following conditions: indoor temp. 27°CDB, 19°CWB; outdoor temp. 35°CDB
- (9) Voltage range: units are suitable for use on electrical systems where voltage supplied to unit terminal is not below or above listed range limits.
- (10) Maximum allowable voltage range variation between phases is 2%.
- (11) Select wire size based on the value of MCA
- (12) Instead of a fuse, use a circuit breaker
- (13) MFA is used to select the circuit breaker and the ground fault circuit interrupter (earth leakage circuit breaker).
- (14) MSC means the maximum current during start up of the compressor
- (15) EN/IEC 61000-3-12: European/international technical standard setting the limits for harmonic currents produced by equipment connected to public low-voltage system with input current $I > 16A$ and $\leq 75A$ per phase
- (16) Ssc: Short-circuit power

2 Options

2 - 1 Options

RXYSQ-P8Y1

No	Item	RXYSQ4	RXYSQ5	RXYSQ6
1	Cool / Heat selector		KRC19-26A6	
2	Fixing box		KJB111A	
3	Refnet header		KHRQ22M29H	
4	Refnet joint		KHRQ22M20TA	
5	Central drain plug		KKPJ5F180	
6	Branch provider (2 rooms)		BPMKS967B2B	
7	Branch provider (3 rooms)		BPMKS967B3B	

4TW33621-3

NOTES

Note: All options are kits.

3 Capacity tables

3 - 1 Cooling Capacity Tables

3

RXYSQ4P8Y1

Total capacity [kW], power Input [kW] (Compressor + Outdoor fan motor)

Combination [%] (Capacity index)	Outdoor air temp. °CDB	Indoor air temp. [°CWB]													
		14.0		16.0		18.0		19.0		20.0		22.0		24.0	
		TC kW	PI kW	TC kW	PI kW	TC kW	PI kW	TC kW	PI kW	TC kW	PI kW	TC kW	PI kW	TC kW	PI kW
130% 14.56 kW	10	9.83	1.33	11.7	1.63	13.6	1.94	14.6	2.09	15.5	2.25	16.6	2.34	16.9	2.23
	12	9.83	1.36	11.7	1.66	13.6	1.97	14.6	2.13	15.5	2.29	16.4	2.32	16.7	2.28
	14	9.83	1.38	11.7	1.69	13.6	2.01	14.6	2.17	15.5	2.33	16.1	2.39	16.5	2.41
	16	9.83	1.41	11.7	1.72	13.6	2.05	14.6	2.25	15.5	2.48	15.9	2.52	16.3	2.54
	18	9.83	1.43	11.7	1.76	13.6	2.18	14.6	2.42	15.4	2.63	15.7	2.65	16.1	2.67
	20	9.83	1.46	11.7	1.87	13.6	2.35	14.6	2.61	15.2	2.76	15.5	2.78	15.9	2.80
	21	9.83	1.50	11.7	1.94	13.6	2.43	14.6	2.70	15.0	2.82	15.4	2.84	15.8	2.86
	23	9.83	1.61	11.7	2.08	13.6	2.61	14.6	2.90	14.8	2.95	15.2	2.97	15.5	2.99
	25	9.83	1.72	11.7	2.23	13.6	2.80	14.4	3.06	14.6	3.08	15.0	3.10	15.3	3.13
	27	9.83	1.84	11.7	2.38	13.6	3.00	14.2	3.19	14.4	3.20	14.8	3.23	15.1	3.26
	29	9.83	1.96	11.7	2.55	13.6	3.21	14.0	3.32	14.2	3.33	14.5	3.36	14.9	3.39
	31	9.83	2.09	11.7	2.72	13.6	3.43	13.8	3.45	14.0	3.46	14.3	3.49	14.7	3.52
	33	9.83	2.23	11.7	2.90	13.4	3.56	13.6	3.58	13.8	3.59	14.1	3.63	14.5	3.66
	35	9.83	2.38	11.7	3.10	13.2	3.69	13.4	3.71	13.6	3.73	13.9	3.76	14.3	3.79
	37	9.83	2.53	11.7	3.30	13.0	3.82	13.2	3.84	13.3	3.86	13.7	3.89	14.0	3.93
	39	9.83	2.70	11.7	3.52	12.8	3.95	13.0	3.97	13.1	3.99	13.5	4.03	13.8	4.06
120% 13.44 kW	10	9.07	1.22	10.8	1.49	12.6	1.77	13.4	1.91	14.3	2.05	16.1	2.34	16.6	2.31
	12	9.07	1.24	10.8	1.51	12.6	1.80	13.4	1.95	14.3	2.09	16.1	2.38	16.4	2.30
	14	9.07	1.26	10.8	1.54	12.6	1.83	13.4	1.98	14.3	2.13	15.9	2.38	16.2	2.40
	16	9.07	1.29	10.8	1.57	12.6	1.87	13.4	2.02	14.3	2.19	15.7	2.51	16.0	2.52
	18	9.07	1.31	10.8	1.60	12.6	1.93	13.4	2.14	14.3	2.36	15.5	2.63	15.8	2.65
	20	9.07	1.34	10.8	1.67	12.6	2.08	13.4	2.30	14.3	2.54	15.3	2.76	15.6	2.78
	21	9.07	1.35	10.8	1.73	12.6	2.15	13.4	2.39	14.3	2.63	15.1	2.83	15.5	2.85
	23	9.07	1.44	10.8	1.85	12.6	2.31	13.4	2.56	14.3	2.82	14.9	2.95	15.3	2.98
	25	9.07	1.54	10.8	1.98	12.6	2.47	13.4	2.74	14.3	3.03	14.7	3.08	15.1	3.11
	27	9.07	1.64	10.8	2.12	12.6	2.65	13.4	2.94	14.2	3.19	14.5	3.21	14.8	3.24
	29	9.07	1.75	10.8	2.26	12.6	2.83	13.4	3.14	14.0	3.32	14.3	3.34	14.6	3.37
	31	9.07	1.87	10.8	2.41	12.6	3.03	13.4	3.36	13.8	3.45	14.1	3.47	14.4	3.50
	33	9.07	1.99	10.8	2.57	12.6	3.23	13.4	3.56	13.5	3.57	13.9	3.60	14.2	3.63
	35	9.07	2.12	10.8	2.74	12.6	3.45	13.2	3.69	13.3	3.70	13.7	3.74	14.0	3.77
	37	9.07	2.25	10.8	2.92	12.6	3.68	13.0	3.82	13.1	3.84	13.4	3.87	13.8	3.90
	39	9.07	2.40	10.8	3.11	12.6	3.93	12.7	3.95	12.9	3.97	13.2	4.00	13.6	4.03
110% 12.32 kW	10	8.31	1.10	9.92	1.34	11.5	1.60	12.3	1.73	13.1	1.86	14.7	2.12	16.3	2.39
	12	8.31	1.12	9.92	1.37	11.5	1.63	12.3	1.76	13.1	1.89	14.7	2.16	16.2	2.38
	14	8.31	1.14	9.92	1.40	11.5	1.66	12.3	1.79	13.1	1.93	14.7	2.20	15.9	2.38
	16	8.31	1.17	9.92	1.42	11.5	1.69	12.3	1.83	13.1	1.97	14.7	2.29	15.7	2.51
	18	8.31	1.19	9.92	1.45	11.5	1.72	12.3	1.88	13.1	2.06	14.7	2.46	15.5	2.64
	20	8.31	1.21	9.92	1.48	11.5	1.83	12.3	2.02	13.1	2.22	14.7	2.65	15.3	2.76
	21	8.31	1.22	9.92	1.52	11.5	1.89	12.3	2.09	13.1	2.30	14.7	2.75	15.2	2.83
	23	8.31	1.28	9.92	1.63	11.5	2.03	12.3	2.24	13.1	2.47	14.7	2.94	15.0	2.96
	25	8.31	1.37	9.92	1.75	11.5	2.17	12.3	2.40	13.1	2.64	14.5	3.07	14.8	3.09
	27	8.31	1.46	9.92	1.86	11.5	2.32	12.3	2.57	13.1	2.83	14.3	3.19	14.6	3.22
	29	8.31	1.55	9.92	1.99	11.5	2.48	12.3	2.75	13.1	3.03	14.0	3.32	14.3	3.35
	31	8.31	1.66	9.92	2.12	11.5	2.65	12.3	2.94	13.1	3.24	13.8	3.45	14.1	3.48
	33	8.31	1.76	9.92	2.26	11.5	2.83	12.3	3.13	13.1	3.46	13.6	3.58	13.9	3.61
	35	8.31	1.87	9.92	2.41	11.5	3.02	12.3	3.34	13.1	3.68	13.4	3.71	13.7	3.74
	37	8.31	1.99	9.92	2.57	11.5	3.22	12.3	3.57	12.9	3.81	13.2	3.84	13.5	3.87
	39	8.31	2.12	9.92	2.73	11.5	3.43	12.3	3.81	12.7	3.94	13.0	3.97	13.3	4.01
100% 11.20 kW	10	7.56	1.00	9.02	1.21	10.5	1.43	11.2	1.55	11.9	1.66	13.4	1.90	14.8	2.14
	12	7.56	1.01	9.02	1.23	10.5	1.46	11.2	1.57	11.9	1.69	13.4	1.94	14.8	2.18
	14	7.56	1.03	9.02	1.25	10.5	1.49	11.2	1.60	11.9	1.73	13.4	1.97	14.8	2.22
	16	7.56	1.05	9.02	1.28	10.5	1.51	11.2	1.64	11.9	1.76	13.4	2.01	14.8	2.31
	18	7.56	1.07	9.02	1.30	10.5	1.54	11.2	1.67	11.9	1.80	13.4	2.13	14.8	2.49
	20	7.56	1.09	9.02	1.33	10.5	1.59	11.2	1.75	11.9	1.92	13.4	2.29	14.8	2.68
	21	7.56	1.10	9.02	1.34	10.5	1.65	11.2	1.82	11.9	1.99	13.4	2.37	14.8	2.78
	23	7.56	1.13	9.02	1.43	10.5	1.76	11.2	1.95	11.9	2.14	13.4	2.54	14.7	2.94
	25	7.56	1.21	9.02	1.53	10.5	1.89	11.2	2.08	11.9	2.29	13.4	2.73	14.5	3.07
	27	7.56	1.28	9.02	1.63	10.5	2.02	11.2	2.23	11.9	2.45	13.4	2.92	14.3	3.20
	29	7.56	1.37	9.02	1.74	10.5	2.15	11.2	2.38	11.9	2.62	13.4	3.12	14.1	3.32
	31	7.56	1.46	9.02	1.85	10.5	2.30	11.2	2.54	11.9	2.79	13.4	3.34	13.9	3.45
	33	7.56	1.55	9.02	1.97	10.5	2.45	11.2	2.71	11.9	2.98	13.4	3.56	13.6	3.58
	35	7.56	1.64	9.02	2.10	10.5	2.61	11.2	2.89	11.9	3.18	13.2	3.69	13.4	3.71
	37	7.56	1.75	9.02	2.23	10.5	2.78	11.2	3.08	11.9	3.39	12.9	3.82	13.2	3.84
	39	7.56	1.86	9.02	2.38	10.5	2.96	11.2	3.28	11.9	3.62	12.7	3.95	13.0	3.98

NOTES - ANMERKUNGEN - Σημειώσεις - NOTAS - REMARQUES - NOTE - OPMERKINGEN - Примечания - NOTLAR

- The above table shows the average value of conditions which may occur.
Die obige Tabelle zeigt den Durchschnittswert der Bedingungen, die auftreten können.
 Στον παραπάνω πίνακα αναγράφεται η μέση τιμή για συνθήκες που μπορεί να προκύψουν.
La tabla de arriba muestra el valor medio de condiciones que pueden ocurrir.
 Le tableau ci-dessus donne la valeur moyenne pour des conditions qui peuvent survenir.
La tabella in alto mostra il valore delle condizioni medie che si possono riscontrare.
 De tabel hierboven geeft de gemiddelde waarde aan van situaties die kunnen voorvallen.
Таблица расположенная выше показывает среднее значение условий, которые могут наступить.
 Yukarıdaki tablo meydana gelebilecek koşulların ortalama değerini göstermektedir.

3 Capacity tables

3 - 1 Cooling Capacity Tables

3

RXYSQ5P8Y1

Total capacity [kW], power Input [kW] (Compressor + Outdoor fan motor)

Combination [%] (Capacity index)	Outdoor air temp. °CDB	Indoor air temp. [°CWB]													
		14.0		16.0		18.0		19.0		20.0		22.0		24.0	
		TC kW	PI kW	TC kW	PI kW	TC kW	PI kW	TC kW	PI kW	TC kW	PI kW	TC kW	PI kW	TC kW	PI kW
130% 18.20 kW	10	12.3	1.66	14.6	2.03	17.0	2.42	18.2	2.62	19.1	2.75	19.6	2.63	20.0	2.51
	12	12.3	1.69	14.6	2.07	17.0	2.47	18.2	2.66	18.9	2.73	19.3	2.61	19.8	2.57
	14	12.3	1.72	14.6	2.11	17.0	2.51	18.2	2.71	18.6	2.71	19.1	2.69	19.5	2.71
	16	12.3	1.76	14.6	2.15	17.0	2.56	18.2	2.80	18.4	2.81	18.8	2.83	19.3	2.86
	18	12.3	1.79	14.6	2.20	17.0	2.73	17.9	2.94	18.1	2.95	18.6	2.98	19.0	3.00
	20	12.3	1.83	14.6	2.34	17.0	2.93	17.7	3.08	17.9	3.10	18.3	3.12	18.8	3.15
	21	12.3	1.88	14.6	2.42	17.0	3.04	17.5	3.15	17.8	3.17	18.2	3.20	18.7	3.22
	23	12.3	2.01	14.6	2.60	17.0	3.26	17.3	3.30	17.5	3.31	18.0	3.34	18.4	3.37
	25	12.3	2.15	14.6	2.78	16.8	3.43	17.1	3.44	17.3	3.46	17.7	3.49	18.2	3.52
	27	12.3	2.30	14.6	2.98	16.6	3.57	16.8	3.59	17.0	3.60	17.5	3.64	17.9	3.67
	29	12.3	2.45	14.6	3.18	16.3	3.71	16.6	3.73	16.8	3.75	17.2	3.78	17.7	3.82
	31	12.3	2.62	14.6	3.40	16.1	3.86	16.3	3.88	16.5	3.90	17.0	3.93	17.4	3.97
	33	12.3	2.79	14.6	3.63	15.8	4.00	16.1	4.02	16.3	4.04	16.7	4.08	17.2	4.12
	35	12.3	2.97	14.6	3.87	15.6	4.15	15.8	4.17	16.0	4.19	16.5	4.23	16.9	4.27
	37	12.3	3.16	14.6	4.13	15.3	4.30	15.6	4.32	15.8	4.34	16.2	4.38	16.7	4.43
	39	12.3	3.37	14.6	4.40	15.1	4.44	15.3	4.47	15.5	4.49	16.0	4.54	16.4	4.58
	120% 16.80 kW	10	11.3	1.52	13.5	1.86	15.7	2.21	16.8	2.38	17.9	2.56	19.3	2.71	19.7
12		11.3	1.55	13.5	1.89	15.7	2.25	16.8	2.43	17.9	2.61	19.0	2.69	19.4	2.58
14		11.3	1.58	13.5	1.93	15.7	2.29	16.8	2.48	17.9	2.66	18.8	2.68	19.2	2.69
16		11.3	1.61	13.5	1.96	15.7	2.34	16.8	2.52	17.9	2.73	18.5	2.82	18.9	2.84
18		11.3	1.64	13.5	2.00	15.7	2.42	16.8	2.67	17.9	2.94	18.3	2.96	18.7	2.98
20		11.3	1.67	13.5	2.08	15.7	2.60	16.8	2.88	17.6	3.08	18.0	3.10	18.4	3.13
21		11.3	1.69	13.5	2.16	15.7	2.69	16.8	2.98	17.5	3.15	17.9	3.18	18.3	3.20
23		11.3	1.80	13.5	2.31	15.7	2.89	16.8	3.20	17.2	3.29	17.7	3.32	18.1	3.35
25		11.3	1.92	13.5	2.47	15.7	3.09	16.8	3.42	17.0	3.44	17.4	3.47	17.8	3.50
27		11.3	2.05	13.5	2.64	15.7	3.31	16.5	3.57	16.7	3.58	17.2	3.61	17.6	3.64
29		11.3	2.19	13.5	2.82	15.7	3.54	16.3	3.71	16.5	3.73	16.9	3.76	17.3	3.79
31		11.3	2.33	13.5	3.01	15.7	3.78	16.0	3.86	16.2	3.87	16.7	3.91	17.1	3.94
33		11.3	2.49	13.5	3.21	15.6	3.98	15.8	4.00	16.0	4.02	16.4	4.06	16.8	4.09
35		11.3	2.65	13.5	3.43	15.3	4.13	15.5	4.15	15.8	4.17	16.2	4.20	16.6	4.24
37		11.3	2.82	13.5	3.65	15.1	4.27	15.3	4.29	15.5	4.31	15.9	4.35	16.3	4.39
39		11.3	3.00	13.5	3.89	14.8	4.42	15.1	4.44	15.3	4.46	15.7	4.50	16.1	4.55
110% 15.40 kW		10	10.4	1.38	12.4	1.68	14.4	1.99	15.4	2.16	16.4	2.32	18.4	2.65	19.3
	12	10.4	1.40	12.4	1.71	14.4	2.03	15.4	2.20	16.4	2.36	18.4	2.70	19.1	2.68
	14	10.4	1.43	12.4	1.74	14.4	2.07	15.4	2.24	16.4	2.41	18.4	2.75	18.8	2.68
	16	10.4	1.46	12.4	1.78	14.4	2.11	15.4	2.28	16.4	2.46	18.2	2.80	18.6	2.82
	18	10.4	1.48	12.4	1.81	14.4	2.15	15.4	2.35	16.4	2.58	18.0	2.94	18.3	2.96
	20	10.4	1.51	12.4	1.85	14.4	2.28	15.4	2.52	16.4	2.77	17.7	3.09	18.1	3.11
	21	10.4	1.53	12.4	1.90	14.4	2.36	15.4	2.61	16.4	2.87	17.6	3.16	18.0	3.18
	23	10.4	1.60	12.4	2.04	14.4	2.53	15.4	2.80	16.4	3.08	17.3	3.30	17.7	3.33
	25	10.4	1.71	12.4	2.18	14.4	2.71	15.4	3.00	16.4	3.30	17.1	3.45	17.5	3.47
	27	10.4	1.82	12.4	2.33	14.4	2.90	15.4	3.21	16.4	3.54	16.8	3.59	17.2	3.62
	29	10.4	1.94	12.4	2.49	14.4	3.10	15.4	3.43	16.2	3.71	16.6	3.74	17.0	3.76
	31	10.4	2.07	12.4	2.65	14.4	3.31	15.4	3.67	16.0	3.85	16.3	3.88	16.7	3.91
	33	10.4	2.20	12.4	2.83	14.4	3.53	15.4	3.92	15.7	3.99	16.1	4.03	16.5	4.06
	35	10.4	2.34	12.4	3.01	14.4	3.77	15.3	4.12	15.5	4.14	15.8	4.17	16.2	4.21
	37	10.4	2.49	12.4	3.21	14.4	4.02	15.0	4.27	15.2	4.29	15.6	4.32	16.0	4.36
	39	10.4	2.65	12.4	3.41	14.4	4.28	14.8	4.41	15.0	4.43	15.4	4.47	15.7	4.51
	100% 14.00 kW	10	9.45	1.24	11.3	1.51	13.1	1.79	14.0	1.93	14.9	2.08	16.7	2.37	18.6
12		9.45	1.27	11.3	1.54	13.1	1.82	14.0	1.97	14.9	2.12	16.7	2.42	18.6	2.72
14		9.45	1.29	11.3	1.56	13.1	1.86	14.0	2.00	14.9	2.16	16.7	2.46	18.5	2.76
16		9.45	1.31	11.3	1.59	13.1	1.89	14.0	2.04	14.9	2.20	16.7	2.51	18.2	2.80
18		9.45	1.34	11.3	1.62	13.1	1.93	14.0	2.08	14.9	2.24	16.7	2.66	18.0	2.94
20		9.45	1.36	11.3	1.66	13.1	1.99	14.0	2.19	14.9	2.40	16.7	2.86	17.7	3.09
21		9.45	1.37	11.3	1.67	13.1	2.06	14.0	2.27	14.9	2.49	16.7	2.96	17.6	3.16
23		9.45	1.41	11.3	1.78	13.1	2.20	14.0	2.43	14.9	2.67	16.7	3.18	17.4	3.30
25		9.45	1.51	11.3	1.91	13.1	2.36	14.0	2.60	14.9	2.86	16.7	3.41	17.1	3.45
27		9.45	1.60	11.3	2.04	13.1	2.52	14.0	2.78	14.9	3.06	16.5	3.57	16.9	3.59
29		9.45	1.71	11.3	2.17	13.1	2.69	14.0	2.97	14.9	3.27	16.3	3.71	16.6	3.74
31		9.45	1.82	11.3	2.31	13.1	2.87	14.0	3.17	14.9	3.49	16.0	3.85	16.4	3.88
33		9.45	1.93	11.3	2.46	13.1	3.06	14.0	3.39	14.9	3.73	15.8	4.00	16.1	4.03
35		9.45	2.05	11.3	2.62	13.1	3.26	14.0	3.61	14.9	3.97	15.5	4.15	15.9	4.18
37		9.45	2.18	11.3	2.79	13.1	3.48	14.0	3.85	14.9	4.24	15.3	4.29	15.6	4.33
39		9.45	2.32	11.3	2.97	13.1	3.70	14.0	4.10	14.7	4.40	15.0	4.44	15.4	4.47

NOTES - ANMERKUNGEN - Σημειώσεις - NOTAS - REMARQUES - NOTE - OPMERKINGEN - Примечания - NOTLAR

- The above table shows the average value of conditions which may occur.
Die obige Tabelle zeigt den Durchschnittswert der Bedingungen, die auftreten können.
 Στον παραπάνω πίνακα αναγράφεται η μέση τιμή για συνθήκες που μπορεί να προκύψουν.
La tabla de arriba muestra el valor medio de condiciones que pueden ocurrir.
 Le tableau ci-dessus donne la valeur moyenne pour des conditions qui peuvent survenir.
La tabella in alto mostra il valore delle condizioni medie che si possono riscontrare.
 De tabel hierboven geeft de gemiddelde waarde aan van situaties die kunnen voorvallen.
Таблица расположенная выше показывает среднее значение условий, которые могут наступить.
 Yukarıdaki tablo meydana gelebilecek koşulların ortalama değerini göstermektedir.

3 Capacity tables

3 - 2 Heating Capacity Tables

3

RXYSQ4P8Y1		Total capacity [kW], power Input [kW] (Compressor + Outdoor fan motor)																													
Combination [%] (Capacity index)	Outdoor air temp.		Indoor air temp. [°CDB]																												
			16.0		18.0		20.0		21.0		22.0		24.0																		
			TC	PI	TC	PI	TC	PI	TC	PI	TC	PI	TC	PI																	
130% 16.25 kW	-19.8	-20	10.2	3.35	10.2	3.49	10.1	3.62	10.1	3.69	10.1	3.76	10.1	3.90																	
	120% 15.00 kW	-19.8	-20	10.1	3.54	10.1	3.66	10.1	3.79	10.1	3.85	10.1	3.91	10.0	4.04																
		110% 13.75 kW	-19.8	-20	10.1	3.72	10.1	3.83	10.1	3.95	10.0	4.01	10.0	4.06	10.0	4.18															
			100% 12.50 kW	-19.8	-20	10.1	3.90	10.0	4.01	10.0	4.11	10.0	4.16	10.0	4.22	10.0	4.32														
					-18.8	-19	10.4	3.96	10.4	4.06	10.3	4.16	10.3	4.21	10.3	4.26	10.3	4.36													
						-16.7	-17	11.0	4.07	11.0	4.16	10.9	4.26	10.9	4.30	10.9	4.35	10.9	4.44												
							-14.7	-15	11.6	4.16	11.6	4.25	11.6	4.34	11.5	4.39	11.5	4.43	10.9	4.14											
								-12.6	-13	12.2	4.25	12.2	4.33	12.2	4.42	12.1	4.43	11.7	4.24	10.9	3.87										
									-10.5	-11	12.8	4.32	12.8	4.40	12.5	4.33	12.1	4.15	11.7	3.97	10.9	3.63									
										-9.5	-10	13.1	4.36	13.1	4.44	12.5	4.20	12.1	4.02	11.7	3.85	10.9	3.52								
											-8.5	-9.1	13.4	4.39	13.3	4.43	12.5	4.08	12.1	3.92	11.7	3.75	10.9	3.43							
												-7.0	-7.6	13.9	4.44	13.3	4.23	12.5	3.91	12.1	3.75	11.7	3.59	10.9	3.29						
													-5.0	-5.6	14.1	4.32	13.3	4.00	12.5	3.70	12.1	3.55	11.7	3.40	10.9	3.12					
														-3.0	-3.7	14.1	4.10	13.3	3.81	12.5	3.52	12.1	3.38	11.7	3.24	10.9	2.97				
															0.0	-0.7	14.1	3.80	13.3	3.53	12.5	3.27	12.1	3.14	11.7	3.01	10.9	2.77			
																3.0	2.2	14.1	3.55	13.3	3.30	12.5	3.06	12.1	2.94	11.7	2.82	10.9	2.59		
																	5.0	4.1	14.1	3.40	13.3	3.16	12.5	2.93	12.1	2.82	11.7	2.71	10.9	2.49	
																		7.0	6	14.1	3.27	13.3	3.04	12.5	2.82	12.1	2.71	11.7	2.61	10.9	2.40
																			9.0	7.9	14.1	3.14	13.3	2.92	12.5	2.72	12.1	2.61	11.7	2.51	10.9
																			11.0	9.8	14.1	3.02	13.3	2.82	12.5	2.62	12.1	2.52	11.7	2.42	10.9
																			13.0	11.8	14.1	2.91	13.3	2.72	12.5	2.52	12.1	2.43	11.7	2.34	10.9
																			15.0	13.7	14.1	2.81	13.3	2.62	12.5	2.44	12.1	2.35	11.7	2.26	10.9

NOTES - ANMERKUNGEN - Σημειώσεις - NOTAS - REMARQUES - NOTE - OPMERKINGEN - Примечания - NOTLAR

1. The above table shows the average value of conditions which may occur.
 Die obige Tabelle zeigt den Durchschnittswert der Bedingungen, die auftreten können.
 Στον παραπάνω πίνακα αναγράφεται η μέση τιμή για συνθήκες που μπορεί να προκύψουν.
 La tabla de arriba muestra el valor medio de condiciones que pueden ocurrir.
 Le tableau ci-dessus donne la valeur moyenne pour des conditions qui peuvent survenir.
 La tabella in alto mostra il valore delle condizioni medie che si possono riscontrare.
 De tabel hierboven geeft de gemiddelde waarde aan van situaties die kunnen voorvallen.
 Таблица расположенная выше показывает среднее значение условий, которые могут наступить.
 Yukarıdaki tablo meydana gelebilecek koşulların ortalama değerini göstermektedir.

3 Capacity tables

3 - 2 Heating Capacity Tables

RXYSQ4P8Y1		Total capacity [kW]. power Input [kW] (Compressor + Outdoor fan motor)																		
Combination [%] (Capacity index)	Outdoor air temp.		Indoor air temp. [°CDB]																	
			16.0		18.0		20.0		21.0		22.0		24.0							
	°CDB	°CWB	TC kW	PI kW	TC kW	PI kW	TC kW	PI kW	TC kW	PI kW	TC kW	PI kW	TC kW	PI kW						
90% 11.25 kW	-19.8	-20	10.0	4.09	10.0	4.18	10.0	4.27	10.0	4.32	10.0	4.37	10.0	4.41	9.80	4.35				
	80% 10.00 kW	-19.8	-20	10.0	4.27	10.0	4.35	10.0	4.44	9.68	4.28	9.36	4.10	8.71	3.74	3.60	3.74			
		70% 8.75 kW	-19.8	-20	9.87	4.39	9.31	4.07	8.75	3.76	8.47	3.61	8.19	3.46	7.63	3.17	3.05	3.17		
			60% 7.50 kW	-19.8	-20	8.46	3.61	7.98	3.35	7.50	3.11	7.26	2.98	7.02	2.87	6.54	2.63	2.54	2.63	
				50% 6.25 kW	-19.8	-20	7.05	2.88	6.65	2.69	6.25	2.50	6.05	2.41	5.85	2.31	5.45	2.13	2.06	2.13
					15.0	13.7	7.05	1.32	6.65	1.25	6.25	1.17	6.05	1.14	5.85	1.10	5.45	1.03	1.03	1.03

4TW33652-2

3 Capacity tables

3 - 2 Heating Capacity Tables

Combination [%] (Capacity index)		Outdoor air temp.		Indoor air temp. [°CDB]											
				16.0		18.0		20.0		21.0		22.0		24.0	
				TC	PI	TC	PI	TC	PI	TC	PI	TC	PI	TC	PI
90% 16.20 kW		°CDB	°CWB	kW		kW		kW		kW		kW		kW	
		-19.8	-20.0	11.1	4.11	11.0	4.26	11.0	4.42	11.0	4.50	11.0	4.58	11.0	4.73
80% 14.40 kW		-18.8	-19.0	11.4	4.19	11.4	4.34	11.4	4.50	11.3	4.57	11.3	4.65	11.3	4.80
		-16.7	-17.0	12.1	4.35	12.1	4.49	12.0	4.64	12.0	4.71	12.0	4.78	12.0	4.92
70% 12.60 kW		-14.7	-15.0	12.7	4.49	12.7	4.63	12.7	4.76	12.7	4.83	12.7	4.90	12.6	5.03
		-12.6	-13.0	13.4	4.62	13.4	4.75	13.4	4.87	13.3	4.94	13.3	5.00	13.3	5.13
60% 10.80 kW		-10.5	-11.0	14.1	4.73	14.1	4.85	14.0	4.98	14.0	5.04	14.0	5.10	14.0	5.22
		-9.5	-10.0	14.4	4.79	14.4	4.90	14.4	5.02	14.3	5.08	14.3	5.14	14.1	5.16
50% 9.00 kW		-8.5	-9.1	14.7	4.83	14.7	4.95	14.7	5.06	14.6	5.12	14.6	5.18	14.1	5.03
		-7.0	-7.6	15.2	4.90	15.2	5.02	15.2	5.13	15.1	5.19	15.1	5.24	14.1	4.82
40% 7.20 kW		-5.0	-5.6	15.9	4.99	15.9	5.10	15.8	5.21	15.7	5.19	15.2	4.98	14.1	4.58
		-3.0	-3.7	16.5	5.07	16.5	5.18	16.2	5.15	15.7	4.95	15.2	4.75	14.1	4.37
30% 5.40 kW		0.0	-0.7	17.5	5.19	17.2	5.17	16.2	4.79	15.7	4.61	15.2	4.43	14.1	4.07
		3.0	2.2	18.3	5.19	17.2	4.84	16.2	4.49	15.7	4.32	15.2	4.15	14.1	3.83
20% 3.60 kW		5.0	4.1	18.3	4.98	17.2	4.64	16.2	4.31	15.7	4.15	15.2	3.99	14.1	3.68
		7.0	6.0	18.3	4.79	17.2	4.47	16.2	4.15	15.7	4.00	15.2	3.84	14.1	3.55
10% 1.80 kW		9.0	7.9	18.3	4.61	17.2	4.30	16.2	4.00	15.7	3.85	15.2	3.71	14.1	3.42
		11.0	9.8	18.3	4.44	17.2	4.15	16.2	3.86	15.7	3.72	15.2	3.58	14.1	3.31
5% 0.90 kW		13.0	11.8	18.3	4.28	17.2	4.00	16.2	3.73	15.7	3.59	15.2	3.46	14.1	3.20
		15.0	13.7	18.3	4.14	17.2	3.87	16.2	3.61	15.7	3.48	15.2	3.35	14.1	3.10

4TW33652-2

3 Capacity tables

3 - 3 Integrated Heating Capacity Correction Factor

3

RXYSQ-P8Y1

INTEGRATED HEATING CAPACITY COEFFICIENT

The heating capacity tables do not take account of the reduction in capacity, when frost has accumulated or while the defrosting operation is in progress.

The capacity values, which take these factors into account, in other words, the integrated heating capacity values, can be calculated as follows:

Formula:

Integrated heating capacity = A

Value given in table of capacity characteristics = B

Integrating correction factor for frost accumulation (kW) = C

$A = B \times C$

Correction factor for finding integrated heating capacity.

Inlet port temperature of heat exchanger (°C/RH 85%)	-7	-5	-3	0	3	5	7
Integrating correction factor for frost accumulation	0,88	0,86	0,8	0,75	0,76	0,82	1.0

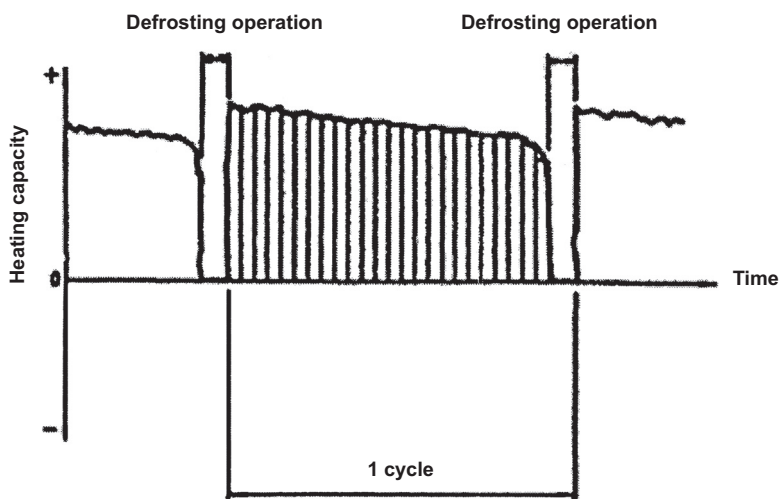

3TW30402

NOTES

1. The figure shows that the integrated heating capacity expresses the integrated capacity for a single cycle (from defrost operation to defrost operation) in terms of time.
2. When there is an accumulation of snow against the outside surface of the outdoor unit heat exchanger, there will always be a temporary reduction in capacity, although this will of course vary in degree in accordance with a number of other factors, such as the outdoor temperature (°CDB), relative humidity (RH) and the amount of frosting which occurs.

3 Capacity tables

3 - 4 Capacity Correction Factor

RXYSQ-P8Y1 - for combination with RA and Sky Air indoor units

Capacity Correction Factor by the Length of Refrigerant Piping

• Rate of Change in Capacity by the Main Piping Length

Rate of Change in Cooling Capacity

Main Piping Length	5	10	15	20	25	30	35	40	45	50	55
Rate of Change in Cooling Capacity	100.0%	98.6%	97.2%	95.9%	94.7%	93.5%	92.3%	91.2%	90.1%	89.1%	88.1%

Rate of Change in Heating Capacity

Main Piping Length	5	10	15	20	25	30	35	40	45	50	55
Rate of Change in Heating Capacity	100.0%	99.5%	99.1%	98.6%	98.2%	97.7%	97.3%	96.9%	96.4%	96.0%	95.6%

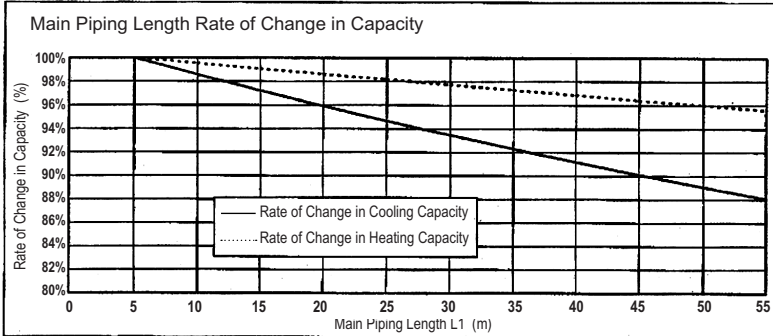

Both cases outdoor unit in inferior or superior for indoor unit, the rate of change in capacity is same

• Rate of Change in Capacity by Branch Piping Length

(1) Refrigerant Piping Connection Diameter
liquid ø 6.4
gas ø 15.9

piping length	Rate of Change in Capacity	
	Cooling	Heating
3	100.0%	100.0%
5	99.6%	99.9%
10	98.7%	99.6%
15	97.9%	99.3%

(2) Refrigerant Piping Connection Diameter
liquid ø 6.4
gas ø 12.7

piping length	Rate of Change in Capacity	
	Cooling	Heating
3	100.0%	100.0%
5	99.1%	99.5%
10	96.9%	98.2%
15	94.8%	97.0%

(3) Refrigerant Piping Connection Diameter
liquid ø 6.4
gas ø 9.5

piping length	Rate of Change in Capacity	
	Cooling	Heating
3	100.0%	100.0%
5	98.0%	98.8%
10	93.4%	96.0%
15	89.3%	93.5%

Piping size for field connection (mm)

Class (KW)	RA		SA	
	Liquid	Gas	Liquid	Gas
25	ø 6.4	ø 9.5	ø 6.4	ø 9.5
35				
42				
50				
60		ø 12.7	ø 6.4	ø 12.7
71				

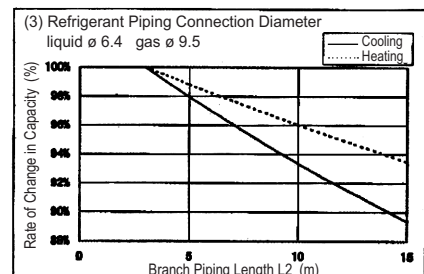
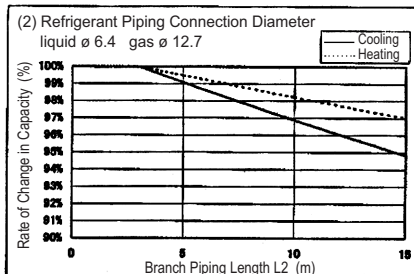
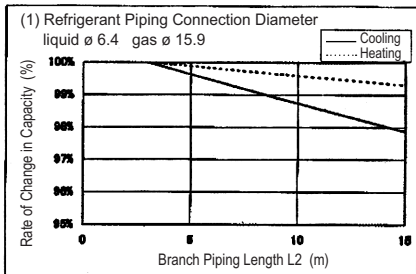

[Method of calculating cooling/heating capacity]

Total capacity from capacity tables x (Rate of change in capacity by main piping length x Rate of change in capacity by branch piping length)

3TW33622-5

NOTES

- These figures illustrate the rate of change in capacity of a standard indoor unit system at maximum load (with the thermostat set to maximum) under standard conditions. Moreover, under partial load conditions there is only a minor deviation from the rate of change in capacity shown in the above figures. With the outdoor unit, evaporating pressure constant control when cooling and condensing pressure constant control when heating is carried out.
- For RXYSQ: use these correction factors in case of installation with bp unit.

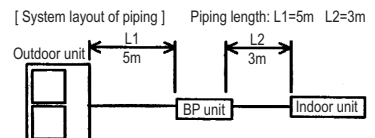

3 Capacity tables

3 - 4 Capacity Correction Factor

3

RXYSQ4,5P8Y1

1. Rate of change in cooling capacity

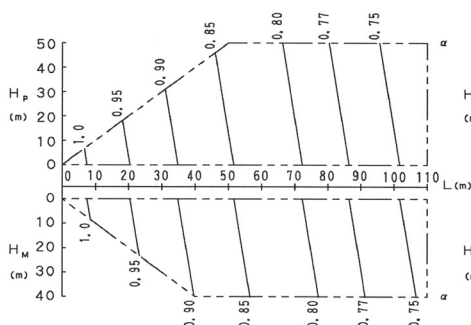

2. Rate of change in heating capacity

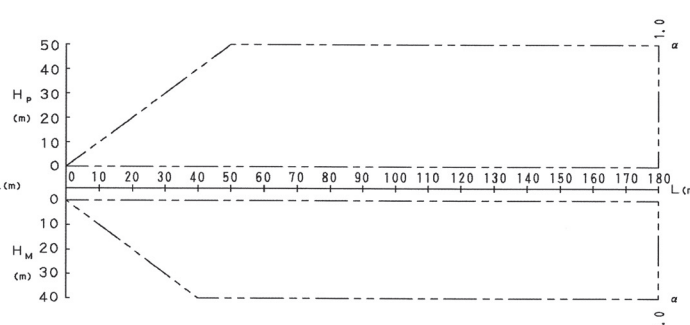

[Explanation of symbols]

- Hp: Level difference (m) between indoor and outdoor units where indoor unit in inferior position
- Hm: Level difference (m) between indoor and outdoor units where indoor unit in superior position
- L: Equivalent pipe length (m)
- α: Capacity correction factor

[Diameter of pipes]

Model	Gas	Liquid
RXYSQ4, 5P8V1	ø 15.9	ø 9.5
RXYSQ4, 5P8Y1		

3TW33622-3

NOTES

1. These figures illustrate the rate of change in capacity of a standard indoor unit system at maximum load (with the thermostat set to maximum) under standard conditions. Moreover, under partial load conditions there is only a minor deviation from the rate of change in capacity shown in the above figures.
2. With this outdoor unit, evaporating pressure constant control when cooling, and condensing pressure constant control when heating is carried out.
3. Method of calculating cooling/heating capacity (max. capacity for combination with standard indoor unit)

$$\text{cooling / heating capacity} = \text{cooling / heating capacity obtained from performance characteristics table} \times \text{each capacity rate of change}$$

In the case length of piping differs depending on the indoor unit, maximum capacity of each unit during simultaneous operation is:

$$\text{cooling / heating capacity} = \text{cooling / heating capacity of each unit} \times \text{capacity rate of change for each piping length}$$

<As for RXYSQ4, 5P8V1 - RXYSQ4, 5P8Y1>

4. When overall equivalent pipe length is 90m or more, the diameter of the main gas pipes (outdoor unit-branch sections) must be increased.
[Diameter of above case]

Model	Gas	Liquid
RXYSQ4, 5P8V1		
RXYSQ4, 5P8Y1	ø 19.1	Not increased

5. When the main sections of the interunit gas pip diameters are increased the overall equivalent length should be calculated as follows.

$$\text{Overall equivalent length} = \text{Equivalent length to main pipe} \times 0.5 + \text{Equivalent length after branching}$$

Example: (RXYSQ4, 5P8V1
RXYSQ4, 5P8Y1)

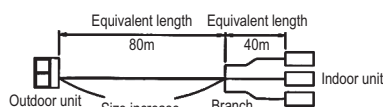

In the above case (Cooling)
Overall equivalent length = 80m x 0.5 + 40m = 80m
The correction factor in capacity when Hp = 0m is thus approximately 0.78

6. For RXYSQ: use these correction factors in case of vrv indoor unit.

3 Capacity tables

3 - 4 Capacity Correction Factor

RXYSQ6P8Y1

1. Rate of change in cooling capacity

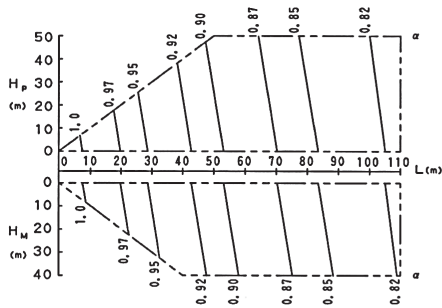

2. Rate of change in heating capacity

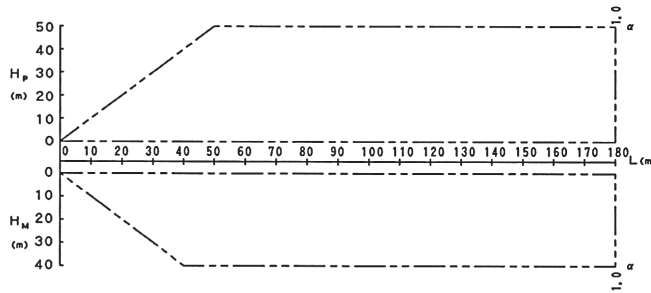

[Explanation of symbols]

- H_p: Level difference (m) between indoor and outdoor units where indoor unit in inferior position
- H_m: Level difference (m) between indoor and outdoor units where indoor unit in superior position
- L: Equivalent pipe length (m)
- c: Capacity correction factor

[Diameter of pipes]

Model	Gas	Liquid
RXYSQ6P8Y1	ø 19.1	ø 9.5

3TW33642-4

NOTES

1. These figures illustrate the rate of change in capacity of a standard indoor unit system at maximum load (with the thermostat set to maximum) under standard conditions. Moreover, under partial load conditions there is only a minor deviation from the rate of change in capacity shown in the above figures.
2. With this outdoor unit, evaporating pressure constant control when cooling, and condensing pressure constant control when heating is carried out.
3. Method of calculating cooling/heating capacity (max. capacity for combination with standard indoor unit)

$$\text{cooling / heating capacity} = \text{cooling / heating capacity obtained from performance characteristics table} \times \text{each capacity rate of change}$$

In the case length of piping differs depending on the indoor unit, maximum capacity of each unit during simultaneous operation is:

$$\text{cooling / heating capacity} = \text{cooling / heating capacity of each unit} \times \text{capacity rate of change for each piping length}$$

<As for RXYMQ6MV4A - RXYSQ6M7V3B - RXYMQ6MVL - RXYMQ6PV4A, RXMQ6PVE - RXMQ6VPE - RXYSQ6P7V3B - RXYSQ6P7Y1B - RXYSQ6PA7V1B - RXYSQPA7Y1B - RXYSQ6P8V1B - RXYSQ6P8Y1B>

4. When overall equivalent pipe length is 90m or more, the diameter of the main gas pipes (outdoor unit-branch sections) must be increased.

[Diameter of above case]

Model	Gas	Liquid
RXYSQ6P8Y1B	ø 22.2	Not increased

5. When the main sections of the interunit gas pip diameters are increased the overall equivalent length should be calculated as follows.

$$\text{Overall equivalent length} = \text{Equivalent length to main pipe} \times 0.5 + \text{Equivalent length after branching}$$

Example: RXYSQ6P8Y1B

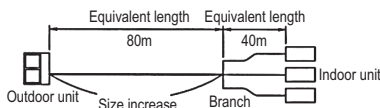

In the above case (Cooling)

$$\text{Overall equivalent length} = 80\text{m} \times 0.5 + 40\text{m} = 80\text{m}$$

The correction factor in capacity when H_p = 0m is thus approximately 0.86

6. For RXYSQ: use these correction factors in case of vrv indoor unit.

4 Dimensional drawings

4 - 1 Dimensional Drawings

4

RXYSQ-P8Y1

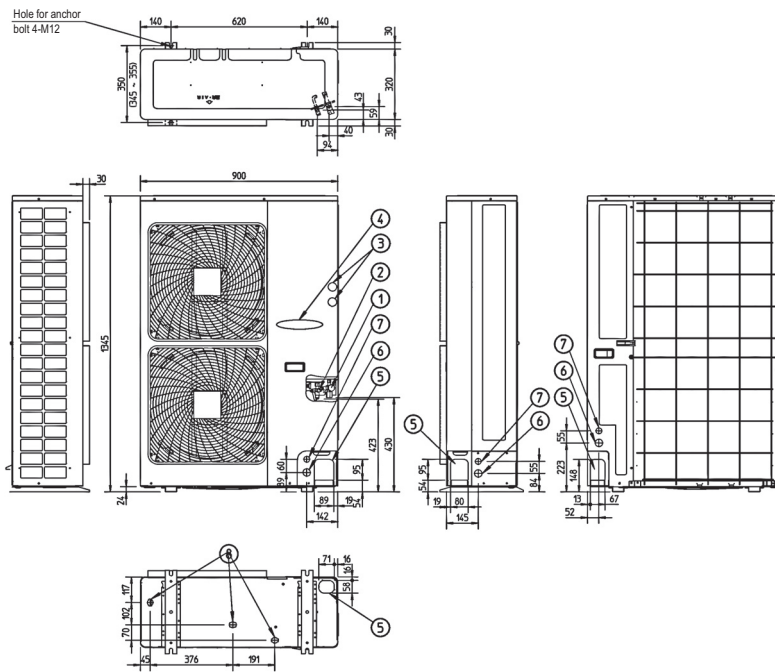

1	Gas pipe connection A
2	Liquid connection pipe Ø9.5 flare
3	Service port (in the unit) (2x)
4	Electronic connection and grounding terminal M5 (in switch box)
5	Refrigerant piping intake
6	Power supply wiring intake (knock hole Ø34)
7	Control wiring intake (knock hole Ø27)
8	Drain outlet

MODEL	A	
	With RA connection	With VRV correction
RXYSQ4P8Y1	Ø19.1 Brazing	Ø15.9 Flare
RXYSQ5P8Y1	Ø19.1 Brazing	Ø15.9 Flare
RXYSQ6P8Y1	Ø19.1 Brazing	Ø19.1 Brazing

3TW30374-1B

5 Centre of gravity

5 - 1 Centre of Gravity

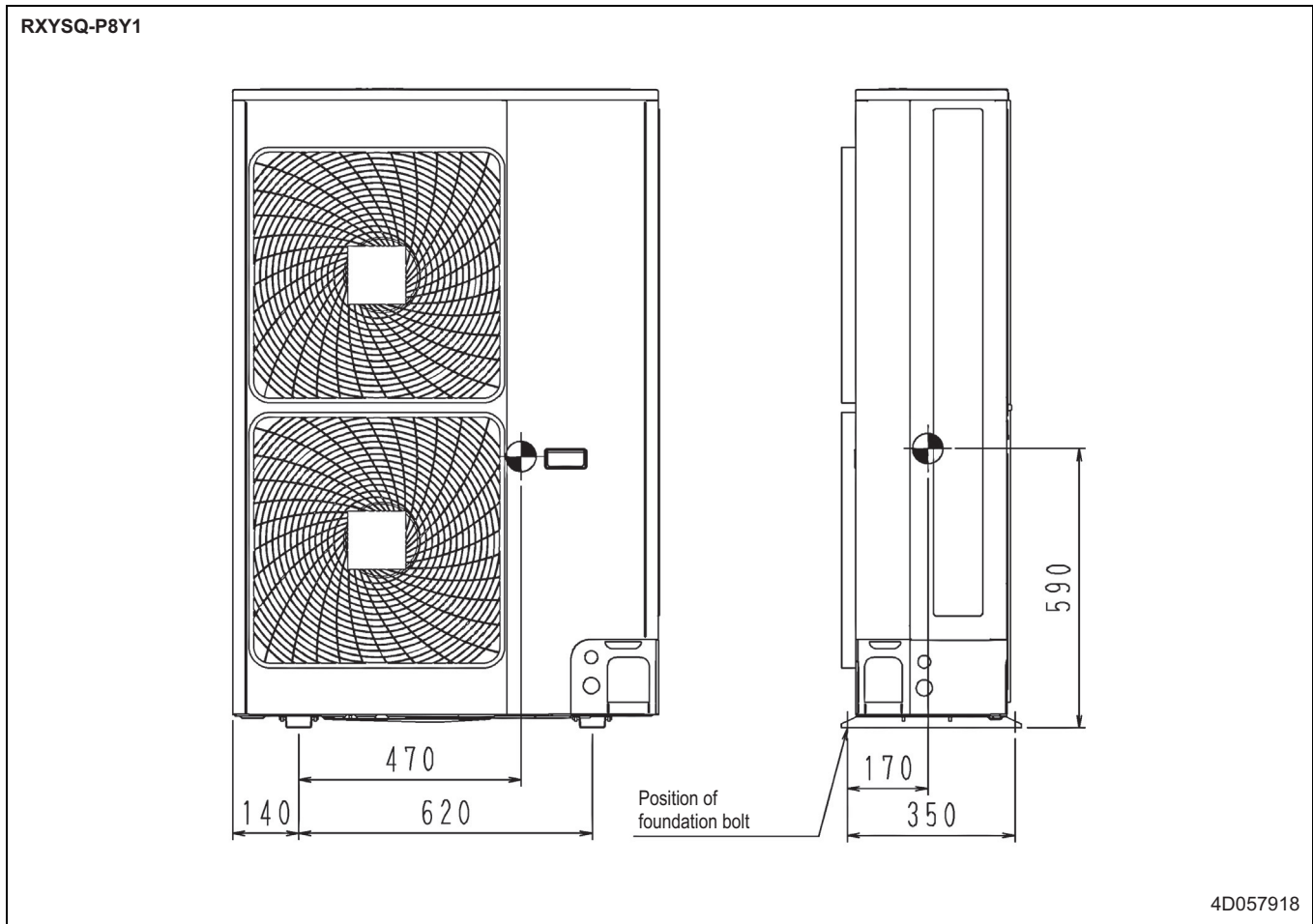

6 Piping diagrams

6 - 1 Piping Diagrams

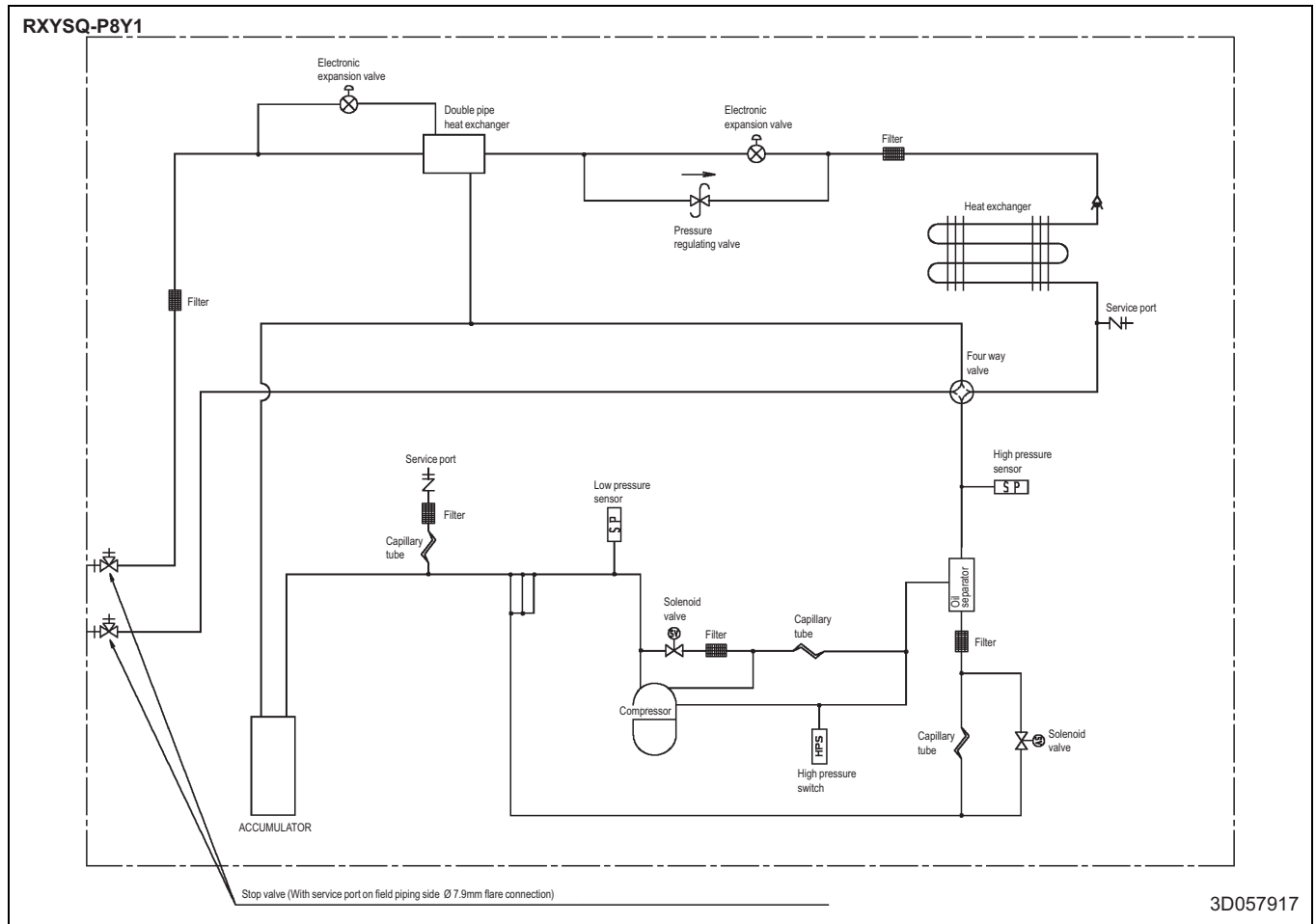

6

7 Wiring diagrams

7 - 1 Wiring Diagrams - Single Phase

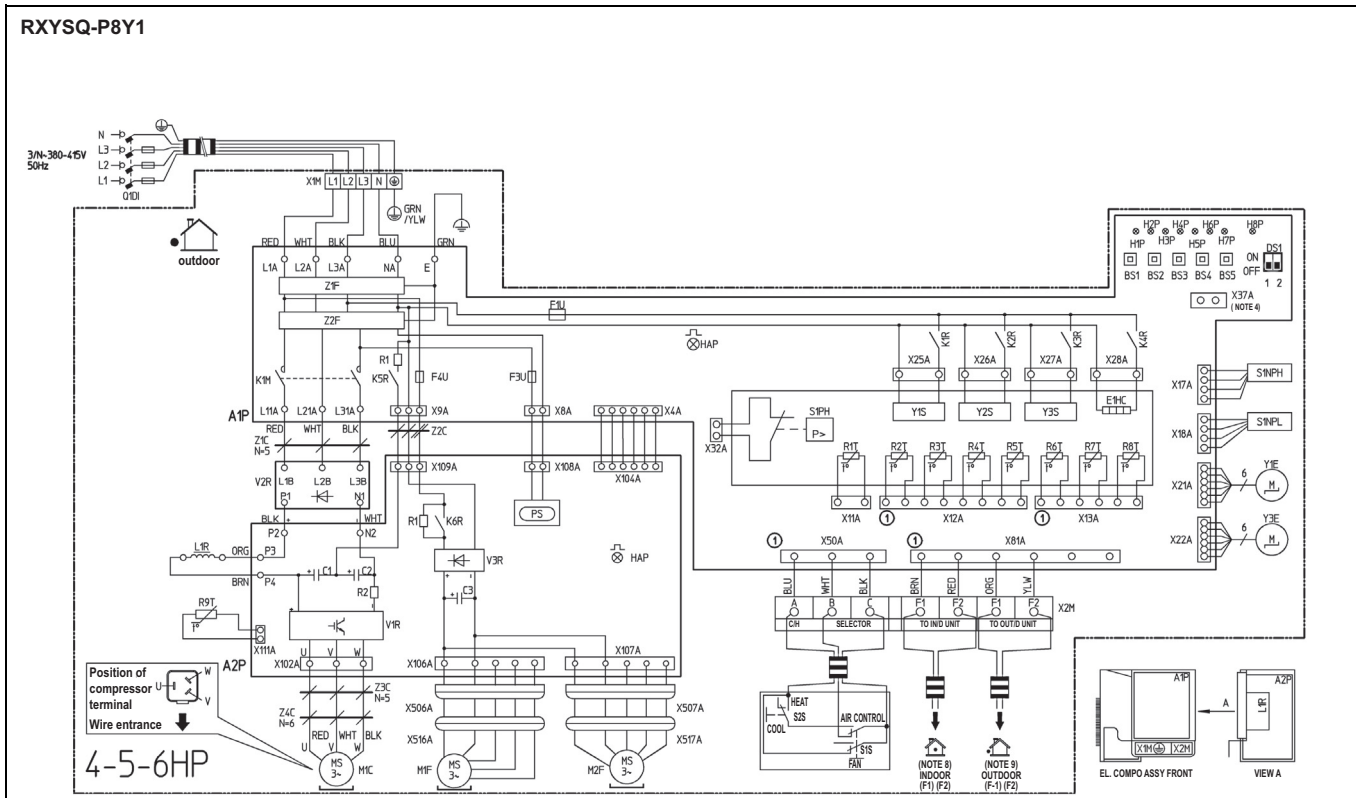

Cool/Heat selector		HAP (A2P)	Light emitting diode (service monitor green)	R5T	Thermistor (suction 2)
S1S	Selector switch (fan / cool - heat)	K1M(A1P)	Magnetic contactor	R6T	Thermistor (heat exchanger)
S2S	Selector switch (cool - heat)	K1R	Magnetic relay (Y1S)	R7T	Thermistor (liquid 1)
Connector of option adaptor		K2R	Magnetic relay (Y2S)	R8T	Thermistor (liquid 2)
X37A (note 4)	Connector (option adaptor power supply)	K3R	Magnetic relay (Y3S)	R9T	Thermistor (power module)
L1~RED	L2~WHT	L3~BLK	N~BLU	K4R	Magnetic relay (E1HC)
A1P	Printed circuit board (main)	L1R	Reactor	S1NPH	Pressure sensor (high)
A2P	Printed circuit board (inv.)	M1C	Motor (compressor)	S1PNL	Pressure sensor (low)
BS1~BS5	Pushbuttonswitch(mode, set, return, test, reset)	M1F	Motor (fan) (upper)	S1PH	Pressure switch (high)
C1~C3	Capacitor	M2F	Motor (fan) (lower)	V1R	Power module
DS1-1	Dip switch	M2F	Motor (fan) (lower)	V2R, V3R	Diode module
E1HC	Crankcase heater	PS	Switching power supply	X1M	Terminal strip (power supply)
F1, 3, 4U (A1P)	Fuse (T 6,3A / 250V)	Q1DI	Field earth leakage breaker (300mA)	X2M	Terminal strip (control) (C/H selector)
H1P~H8P	Light emit. diode (serv. monitor-orange) [H2P] Prepare, test ----- flickering Malfunction detection --- light up	R1(A1P)	Resistor	Y1E	Electronic expansion valve (main)
HAP (A1P)	Light emitting diode (service monitor green)	R1(A2P)	Resistor	Y3E	Electronic expansion valve (subcool)
		R2(A2P)	Resistor	Y1S	Solenoid valve (4 way valve)
		R3T	Thermistor (suction 1)	Y2S	Solenoid valve (hot gas)
		R4T	Thermistor (subcool)	Y3S	Solenoid valve (U/L circuit)
				Z1C~Z4C	Noise filter (ferrite core)
				Z1F	Noise filter (with surge absorbed)
				Z2F	Noise filter

2TW29226-1B

NOTES

- This wiring diagram only applies to the outdoor unit.
- L: Live, N: Neutral
- Terminal strip: Connector: Movable connector: Noiseless earth:
- When using the option adapter, refer to the installation manual
- Refer to the 'Installation or service manual' on how to use BS1 ~ BS5 push button switch and DS1-1, DS1-2 dip switch.
- Do not operate the unit by short-circuiting protection device S1PH.
- Colors: BLU = BLUE, BRN = BROWN, GRN = GREEN, RED = RED, WHT = WHITE, YLW = YELLOW, ORG = ORANGE, BLK = BLACK.
- Refer to the installation manual for connection wiring to indoor - outdoor transmission F1-F2.
- When using the central control system, connect outdoor-outdoor transmission F1-F2.

8 External connection diagrams

8 - 1 External Connection Diagrams

8

RXYSQ-P8Y1

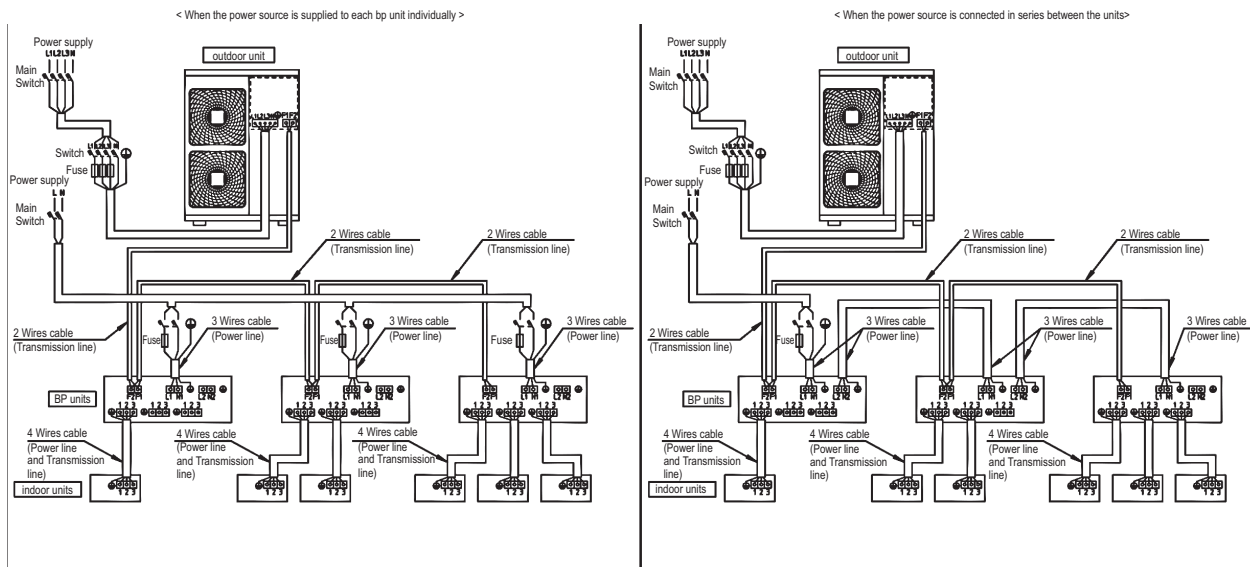

3TW33656-1

NOTES

1. All wiring, components and materials to be procured on the site must comply with the applicable local and national codes.
2. Use copper conductors only.
3. As for details, see wiring diagram.
4. Install circuit breaker for safety.
5. All field wiring and components must be provided by licensed electrician.
6. Unit shall be grounded in compliance with the applicable local and national codes.
7. Wiring shown are general points-of-connection guides only and are not intended for or to include all details for a specific installation.
8. Be sure to install the switch and the fuse to the power line of each equipment.
9. Install the main switch that can interrupt all the power sources in an integrated manner because this system consists of the equipment utilizing the multiple power sources.
10. If there exists the possibility of reversed phase, lose phase, momentary blackout or the power goes on and off while the product is operating, attach a reversed phase protection circuit locally. Running the product in reversed phase may break the compressor and other parts.

RXYSQ-P8Y1

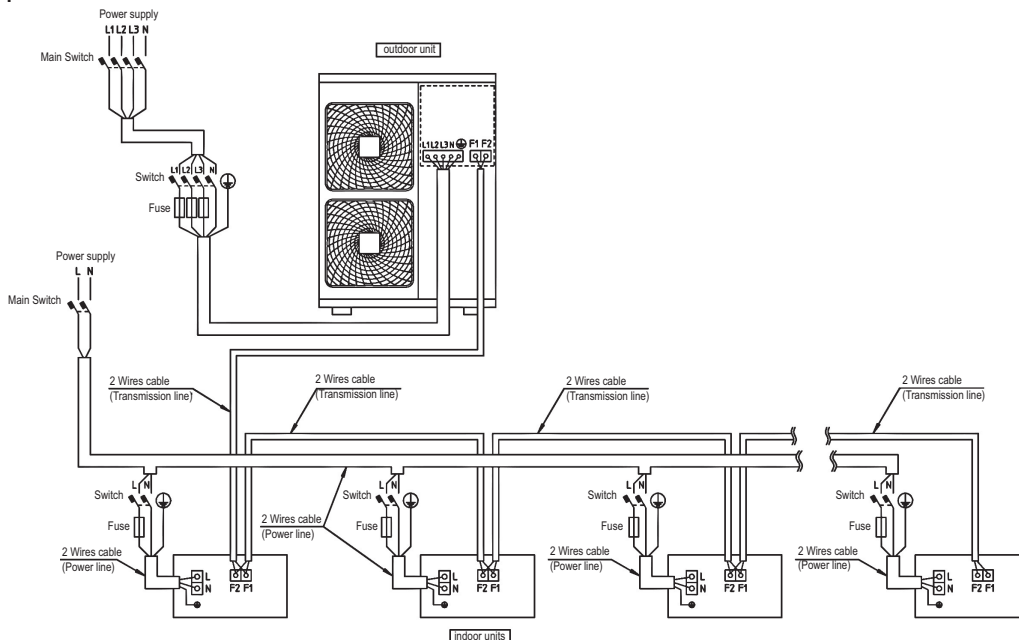

3TW33656-2

NOTES

1. All wiring, components and materials to be procured on the site must comply with the applicable local and national codes.
2. Use copper conductors only.
3. As for details, see wiring diagram.
4. Install circuit breaker for safety.
5. All field wiring and components must be provided by licensed electrician.
6. Unit shall be grounded in compliance with the applicable local and national codes.
7. Wiring shown are general points-of-connection guides only and are not intended for or to include all details for a specific installation.
8. Be sure to install the switch and the fuse to the power line of each equipment.
9. Install the main switch that can interrupt all the power sources in an integrated manner because this system consists of the equipment utilizing the multiple power sources.
10. If there exists the possibility of reversed phase, lose phase, momentary blackout or the power goes on and off while the product is operating, attach a reversed phase protection circuit locally. Running the product in reversed phase may break the compressor and other parts.

9 Sound data

9 - 1 Sound Power Spectrum

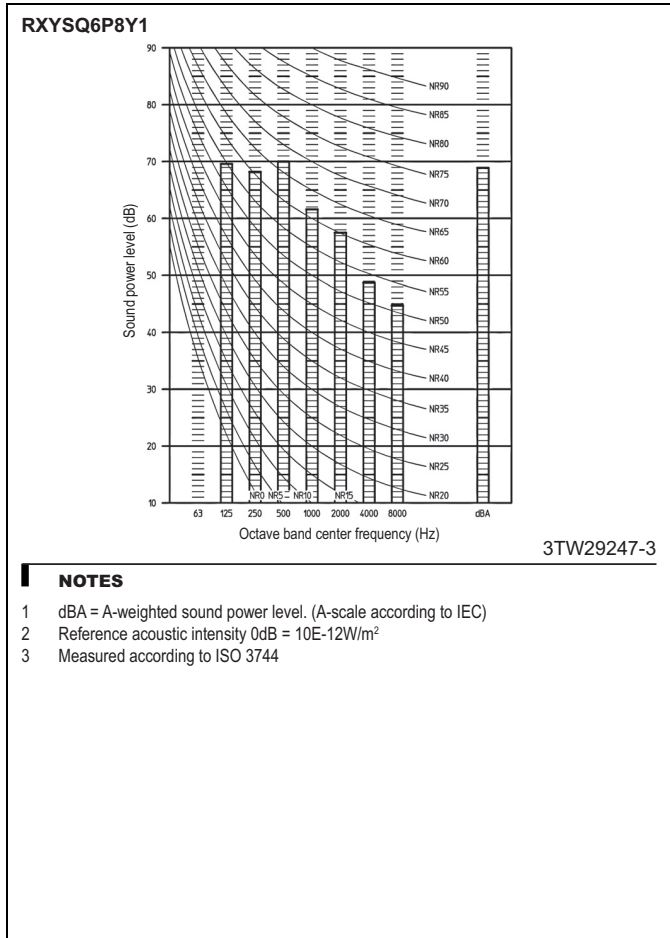
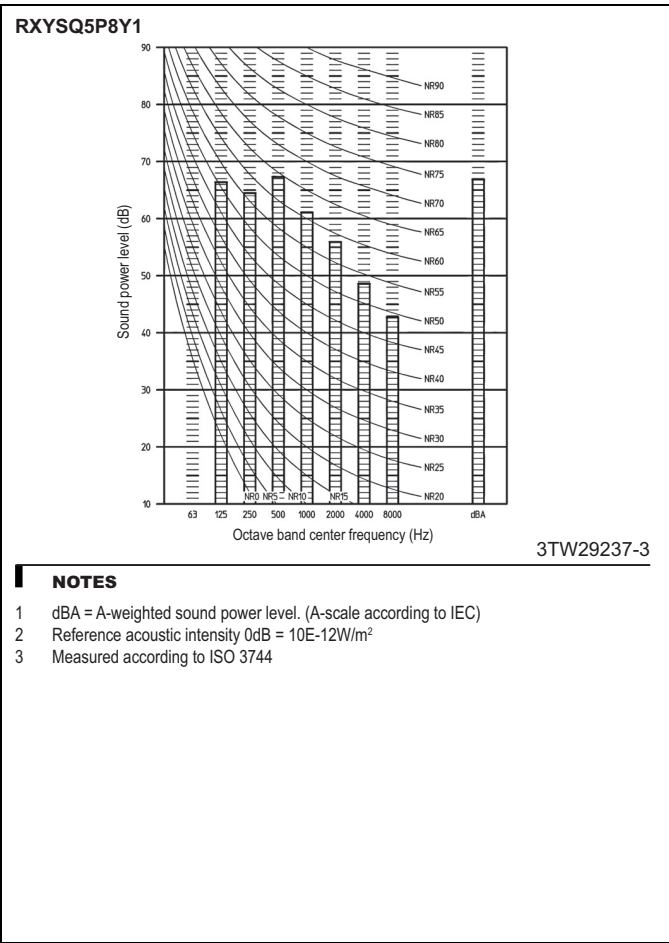
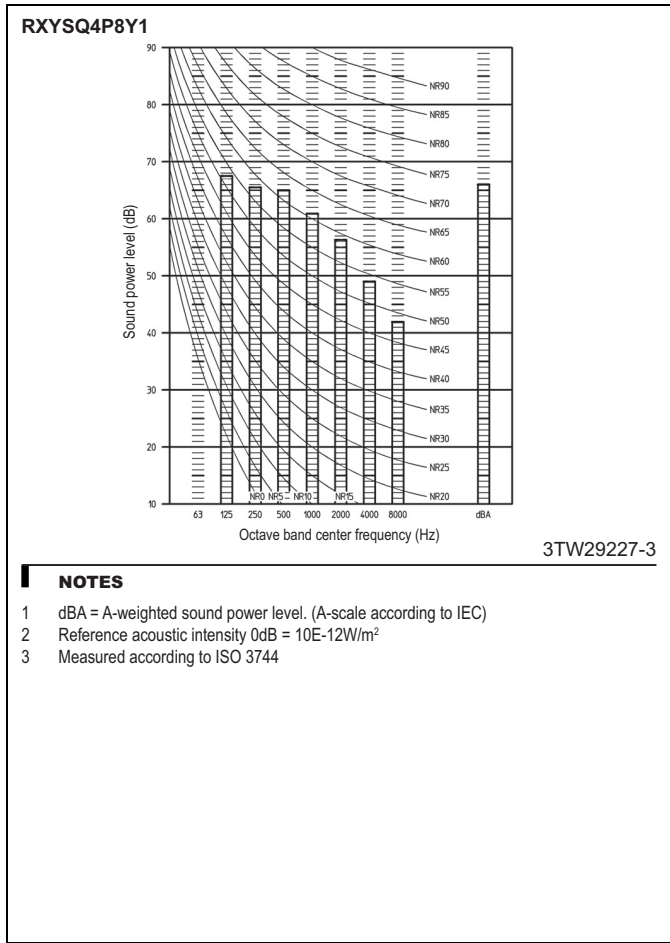

9 Sound data

9 - 2 Sound Pressure Spectrum

9

RXYSQ4P8Y1

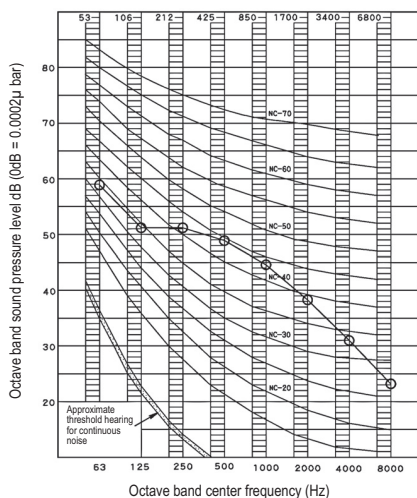

4D057920

NOTES

- Over All (dB): (B,G,N is already rectified)
- Operating conditions:
Power source: 380-415V 50Hz
Cooling return air temperature: 27°C DB, 19°C WB
outdoor temperature: 35°C DB, 24°C WB
- Measuring place: Anechoic chamber
- The operating sound is measured in anechoic chamber, if it is measured under the actual installation conditions, it is normally over the set value due to environmental noise and sound reflection.
- Location of microphone.

Scale	50 Hz
A	50.0
C	62.0

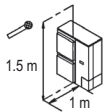

RXYSQ4P8Y1

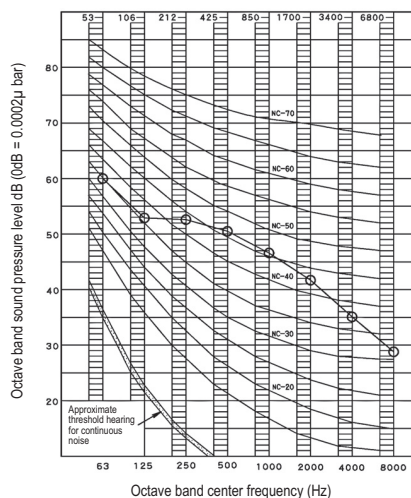

4D057923

NOTES

- Over All (dB): (B,G,N is already rectified)
- Operating conditions:
Power source: 380-415V 50Hz
Cooling return air temperature: 20°C DB
outdoor temperature: 7°C DB, 6°C WB
- Measuring place: Anechoic chamber
- The operating sound is measured in anechoic chamber, if it is measured under the actual installation conditions, it is normally over the set value due to environmental noise and sound reflection.
- Location of microphone.

Scale	50 Hz
A	52.0
C	63.5

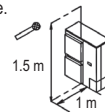

RXYSQ5P8Y1

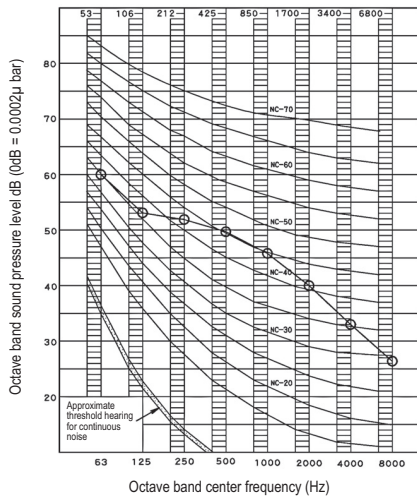

4D057921

NOTES

- Over All (dB): (B,G,N is already rectified)
- Operating conditions:
Power source: 380-415V 50Hz
Cooling return air temperature: 27°C DB, 19°C WB
outdoor temperature: 35°C DB, 24°C WB
- Measuring place: Anechoic chamber
- The operating sound is measured in anechoic chamber, if it is measured under the actual installation conditions, it is normally over the set value due to environmental noise and sound reflection.
- Location of microphone.

Scale	50 Hz
A	51.0
C	63.5

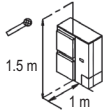

RXYSQ5P8Y1

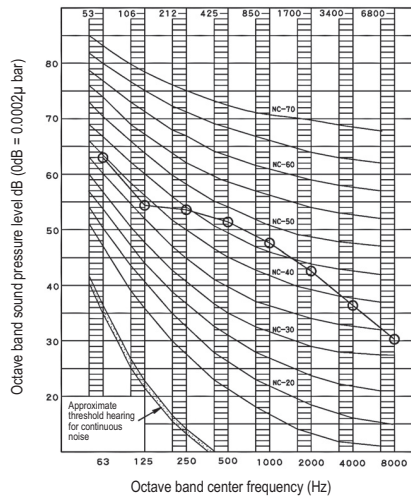

4D057924

NOTES

- Over All (dB): (B,G,N is already rectified)
- Operating conditions:
Power source: 380-415V 50Hz
Cooling return air temperature: 20°C DB
outdoor temperature: 7°C DB, 6°C WB
- Measuring place: Anechoic chamber
- The operating sound is measured in anechoic chamber, if it is measured under the actual installation conditions, it is normally over the set value due to environmental noise and sound reflection.
- Location of microphone.

Scale	50 Hz
A	53.0
C	65.3

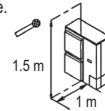

9 Sound data

9 - 2 Sound Pressure Spectrum

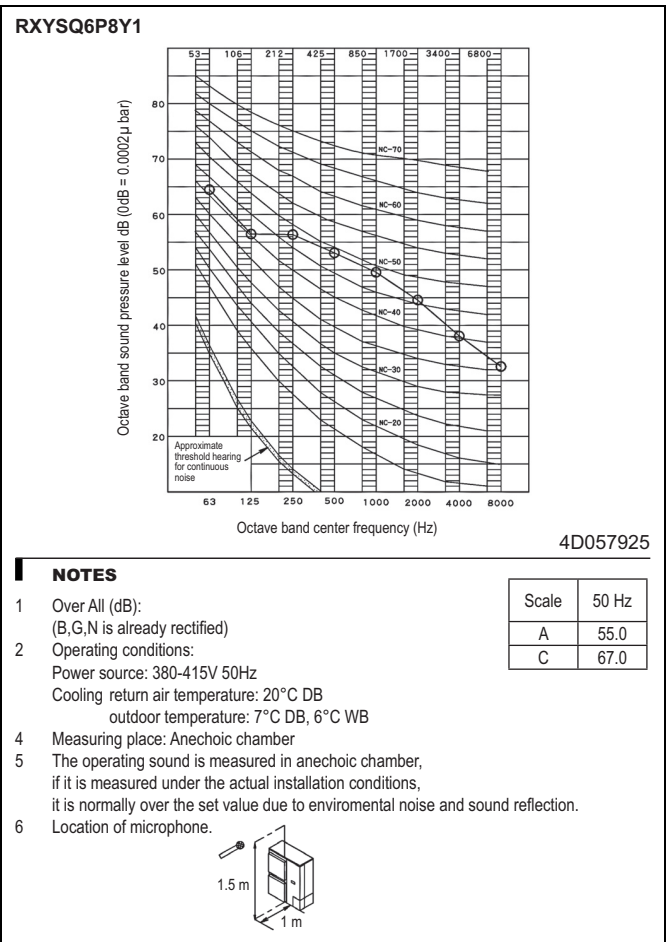
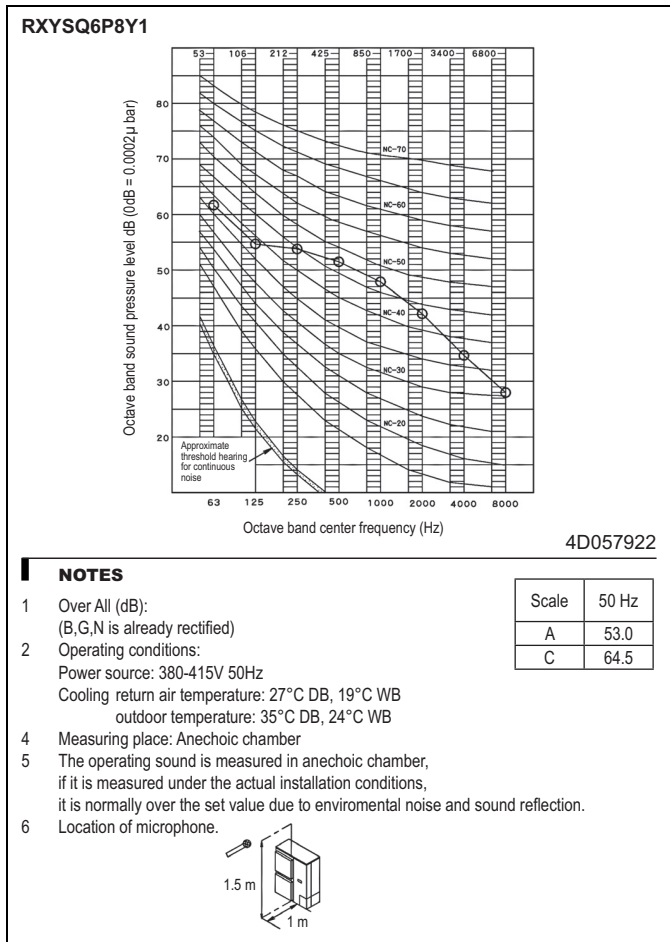

10 Installation

10 - 1 Service Space

10

RXYSQ-P8Y1

Required installation space

(The unit of these values is 'mm')

1. Where there is an obstacle on the suction side:

(a) No obstacle above

(1) Stand-alone installation

- Obstacle on the suction side only

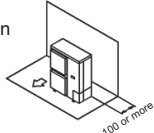

- Obstacle on both sides

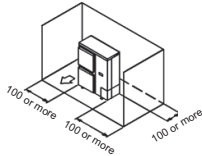

(2) Series installation (2 or more)

- Obstacle on both sides

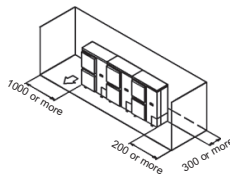

(b) Obstacle above, too

(1) Stand-alone installation

- Obstacle on the suction side, too

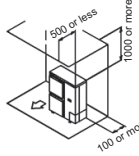

- Obstacle on the suction side and both sides

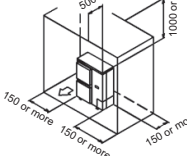

(2) Series installation (2 or more)

- Obstacle on the suction side and both sides

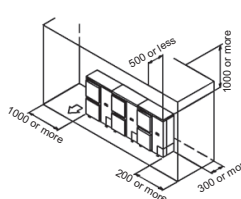

2. Where there is an obstacle on the discharge side:

(a) No obstacle above

(1) Stand-alone installation

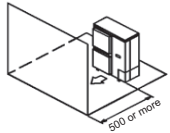

(2) Series installation (2 or more)

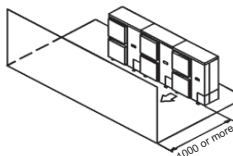

(a) Obstacle above, too

(1) Stand-alone installation

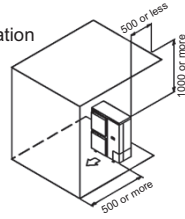

(2) Series installation (2 or more)

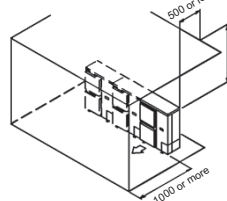

3. Where there are obstacles on both suction and discharge sides:

Pattern 1

Where the obstacle on the discharge side is higher than the unit:

(There is no height limit for obstructions on the intake side)

(a) No obstacle above

(1) Stand-alone installation

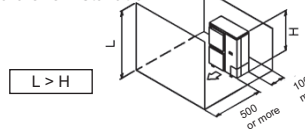

(2) Series installation (2 or more)

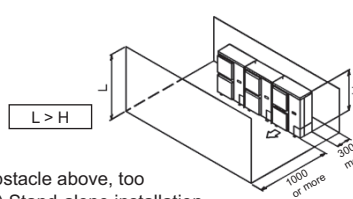

(b) Obstacle above, too

(1) Stand-alone installation

The relations between H, A and L are as follows

	L	A
L ≤ H	0 < L ≤ 1/2 H	750
	1/2 H < L ≤ H	1000
H < L	Set the stand as: L ≤ H	

Close the bottom of the installation frame to prevent the discharged air from being bypassed.

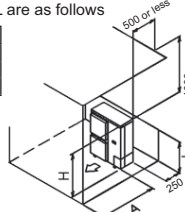

(2) Series installation (2 or more)

The relations between H, A and L are as follows:

	L	A
L ≤ H	0 < L ≤ 1/2 H	1000
	1/2 H < L ≤ H	1250
H < L	Set the stand as: L ≤ H	

Close the bottom of the installation frame to prevent the discharged air from being bypassed.

Only two units can be installed for this series

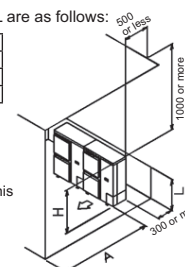

Pattern 2

Where the obstacle on the discharge side is lower than the unit:

(There is no height limit for obstructions on the intake side)

(a) No obstacle above

(1) Stand-alone installation

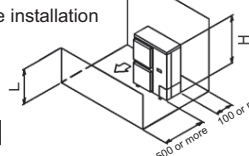

(2) Series installation (2 or more)

The relations between H, A and L are as follows

	L	A
0 < L ≤ 1/2 H		250
1/2 H < L ≤ H		300

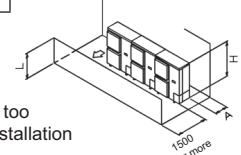

(b) Obstacle above, too

(1) Stand-alone installation

The relations between H, A and L are as follows:

	L	A
L ≤ H	0 < L ≤ 1/2 H	100
	1/2 H < L ≤ H	200
H > L	Set the stand as: L ≤ H	

Close the bottom of the installation frame to prevent the discharged air from being bypassed.

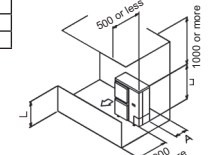

(2) Series installation

The relations between H, A and L are as follows

	L	A
L ≤ H	0 < L ≤ 1/2 H	250
	1/2 H < L ≤ H	300
H < L	Set the stand as: L ≤ H Refer to the column of L ≤ H for A	

Close the bottom of the installation frame to prevent the discharged air from being bypassed.

Only two units can be installed for this series.

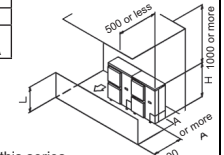

4. Double-decker installation

- (a) Obstacle on the discharge side close the gap A (the gap between the upper and lower outdoor units) to prevent the discharged air from being bypassed.

Do not stack more than two units.

- (b) Obstacle on the suction side close the gap A (the gap between the upper and lower outdoor units) to prevent the discharged air from being bypassed.

Do not stack more than two units.

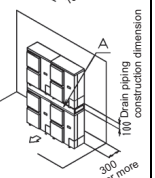
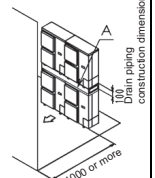

5. Multiple rows of series installation (on the rooftop, etc.)

(a) One row of stand-alone installation

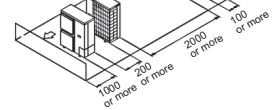

(b) Rows of series installation (2 or more)

The relations between H, A and L are as follows

	L	A
L ≤ H	0 < L ≤ 1/2 H	250
	1/2 H < L ≤ H	300
H < L	Can not be installed	

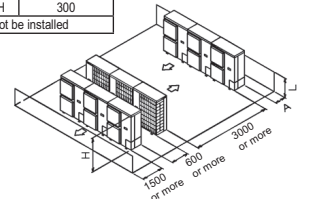

3D045696D

10 Installation

10 - 2 Refrigerant Pipe Selection

RXYSQ-P8Y1

Example of connection (Connection of 8 indoor units Heat pump system)		Branch with refnet joint	Branch with refnet joint and refnet header	Branch with refnet header																
Maximum allowable length	Between outdoor and indoor units	Pipe length between outdoor and indoor units ≤150 m [Example] unit 8: a+b+c+d+e+f+g+p ≤150 m	[Example] unit 6: a+b+h ≤ 150m, unit 8: a+i+k ≤150 m	[Example] unit 8: a+i ≤150 m																
	Equivalent length	Equivalent pipe length between outdoor and indoor units ≤175 m (Assume equivalent pipe length of refnet joint to be 0.5 m and of the refnet header to be 1.0 m. (for calculation purposes))																		
	Total extension length	Total piping length from outdoor unit to all indoor units between 10 m and 300 m																		
Allowable height	Between outdoor and indoor units	Difference in height between outdoor and indoor units (H1) ≤50 m (≤40 m if outdoor unit is located in a lower position).																		
	Between indoor and indoor units	Difference in height between adjacent indoor units (H2) ≤15 m																		
Allowable length after the branch	Actual pipe length	Pipe length from first refrigerant branch kit (either refnet joint or refnet header) to indoor unit ≤40 m [Example] unit 8: b+c+d+e+f+g+p ≤40 m	[Example] unit 6: b+h40 m, unit 8: i+k ≤40 m	[Example] unit 8: i ≤40 m																
Refrigerant branch kit selection		Use the following refnet joint		Use the following refnet header																
Refrigerant branch kits can only be used with R410A.		Outdoor unit capacity type: RXYSQ4-6	Refrigerant branch kit name: KHRQ22M20T	Outdoor unit capacity type: RXYSQ4-6																
Refrigerant branch kit name: KHRQ22M29H				Refrigerant branch kit name: KHRQ22M29H																
Pipe size selection Caution on selecting connection pipes If the overall equivalent piping length is ≥90 m, be sure to enlarge the pipe diameter of the gas-side main piping. If the recommended pipe size is not available, stick to the original pipe diameter (which may result in a small capacity decrease). [Gas side] RXYSQ4+5: → Ø15.9 Ø19.1 RXYSQ6: → Ø19.1 Ø22.2		A. Piping between outdoor unit and refrigerant branch kit • Match to the size of the connection piping on the outdoor unit. Outdoor unit connection piping size <table border="1"> <thead> <tr> <th rowspan="2">Outdoor unit capacity type</th> <th colspan="2">Piping size (outer diameter x minimum thickness)</th> </tr> <tr> <th>Gas pipe</th> <th>Liquid pipe</th> </tr> </thead> <tbody> <tr> <td>RXYSQ4+5</td> <td>Ø15.9x1.0 (Ø19.1x1.0)</td> <td rowspan="2">Ø9.5x0.8</td> </tr> <tr> <td>RXYSQ6</td> <td>Ø19.1x1.0 (Ø22.2x1.0)</td> </tr> </tbody> </table>		Outdoor unit capacity type	Piping size (outer diameter x minimum thickness)		Gas pipe	Liquid pipe	RXYSQ4+5	Ø15.9x1.0 (Ø19.1x1.0)	Ø9.5x0.8	RXYSQ6	Ø19.1x1.0 (Ø22.2x1.0)	B. Piping between refrigerant branch kits • Use the pipe size from the following table. <table border="1"> <thead> <tr> <th colspan="2">Piping size (outer diameter x minimum thickness)</th> </tr> <tr> <th>Gas pipe</th> <th>Liquid pipe</th> </tr> </thead> <tbody> <tr> <td>Ø15.9x1.0</td> <td>Ø9.5x0.8</td> </tr> </tbody> </table>	Piping size (outer diameter x minimum thickness)		Gas pipe	Liquid pipe	Ø15.9x1.0	Ø9.5x0.8
Outdoor unit capacity type	Piping size (outer diameter x minimum thickness)																			
	Gas pipe	Liquid pipe																		
RXYSQ4+5	Ø15.9x1.0 (Ø19.1x1.0)	Ø9.5x0.8																		
RXYSQ6	Ø19.1x1.0 (Ø22.2x1.0)																			
Piping size (outer diameter x minimum thickness)																				
Gas pipe	Liquid pipe																			
Ø15.9x1.0	Ø9.5x0.8																			
<p>1 Main pipe (enlarge) 2 First refrigerant branch kit 3 Indoor unit</p>		C. Piping between refrigerant branch kit and indoor unit • Pipe size for direct connection to indoor unit must be the same as the connection size of indoor unit. <table border="1"> <thead> <tr> <th rowspan="2">Indoor capacity index</th> <th colspan="2">Piping size (outer diameter x minimum thickness)</th> </tr> <tr> <th>Gas pipe</th> <th>Liquid pipe</th> </tr> </thead> <tbody> <tr> <td>20+25+32+40+50</td> <td>Ø12.7x08</td> <td>Ø6.4x0.8</td> </tr> <tr> <td>63+80+100+125</td> <td>Ø15.9x1.0</td> <td>Ø9.5x0.8</td> </tr> </tbody> </table>		Indoor capacity index	Piping size (outer diameter x minimum thickness)		Gas pipe	Liquid pipe	20+25+32+40+50	Ø12.7x08	Ø6.4x0.8	63+80+100+125	Ø15.9x1.0	Ø9.5x0.8						
Indoor capacity index	Piping size (outer diameter x minimum thickness)																			
	Gas pipe	Liquid pipe																		
20+25+32+40+50	Ø12.7x08	Ø6.4x0.8																		
63+80+100+125	Ø15.9x1.0	Ø9.5x0.8																		
How to calculate the additional refrigerant to be charged Additional refrigerant to be charged R (kg) R should be rounded o in units of 0.1 kg		$R = \left(\text{Total length (m) of liquid piping size at } \varnothing 9.5 \right) \times 0.054 + \left(\text{Total length (m) of liquid piping size at } \varnothing 6.4 \right) \times 0.022$		Example for refrigerant branch using refnet joint and refnet header <table border="1"> <tr> <td>a: Ø9.5x3 m</td> <td>d: Ø9.5x13 m</td> <td>g: Ø6.4x10 m</td> <td>j: Ø6.4x10 m</td> </tr> <tr> <td>b: Ø9.5x10 m</td> <td>e: Ø6.4x10 m</td> <td>h: Ø6.4x20 m</td> <td>k: Ø6.4x9 m</td> </tr> <tr> <td>c: Ø9.5x10 m</td> <td>f: Ø6.4x10 m</td> <td>i: Ø9.5x10 m</td> <td></td> </tr> </table> $R = [73 \times 0.054] + [69 \times 0.022] = 5.46 \Rightarrow 5.5 \text{ kg}$	a: Ø9.5x3 m	d: Ø9.5x13 m	g: Ø6.4x10 m	j: Ø6.4x10 m	b: Ø9.5x10 m	e: Ø6.4x10 m	h: Ø6.4x20 m	k: Ø6.4x9 m	c: Ø9.5x10 m	f: Ø6.4x10 m	i: Ø9.5x10 m					
a: Ø9.5x3 m	d: Ø9.5x13 m	g: Ø6.4x10 m	j: Ø6.4x10 m																	
b: Ø9.5x10 m	e: Ø6.4x10 m	h: Ø6.4x20 m	k: Ø6.4x9 m																	
c: Ø9.5x10 m	f: Ø6.4x10 m	i: Ø9.5x10 m																		

4PW66304-1

RXYSQ-P8Y1B

Example of connection (Connection of 8 indoor units Heat pump system)		Branch with refnet joint	Branch with refnet joint and refnet header	Branch with refnet header																
Maximum allowable length	Between outdoor and indoor units	Pipe length between outdoor and indoor units ≤150 m [Example] unit 8: a+b+c+d+e+f+g+p ≤150 m	[Example] unit 6: a+b+h ≤ 150m, unit 8: a+i+k ≤150 m	[Example] unit 8: a+i ≤150 m																
	Equivalent length	Equivalent pipe length between outdoor and indoor units ≤175 m (Assume equivalent pipe length of refnet joint to be 0.5 m and of the refnet header to be 1.0 m. (for calculation purposes))																		
	Total extension length	Total piping length from outdoor unit to all indoor units between 10 m and 300 m																		
Allowable height	Between outdoor and indoor units	Difference in height between outdoor and indoor units (H1) ≤50 m (≤40 m if outdoor unit is located in a lower position).																		
	Between indoor and indoor units	Difference in height between adjacent indoor units (H2) ≤15 m																		
Allowable length after the branch	Actual pipe length	Pipe length from first refrigerant branch kit (either refnet joint or refnet header) to indoor unit ≤40 m [Example] unit 8: b+c+d+e+f+g+p ≤40 m	[Example] unit 6: b+h40 m, unit 8: i+k ≤40 m	[Example] unit 8: i ≤40 m																
Refrigerant branch kit selection		Use the following refnet joint		Use the following refnet header																
Refrigerant branch kits can only be used with R410A.		Outdoor unit capacity type: RXYSQ4-6	Refrigerant branch kit name: KHRQ22M20T	Outdoor unit capacity type: RXYSQ4-6																
Refrigerant branch kit name: KHRQ22M29H				Refrigerant branch kit name: KHRQ22M29H																
Pipe size selection Caution on selecting connection pipes If the overall equivalent piping length is ≥90 m, be sure to enlarge the pipe diameter of the gas-side main piping. If the recommended pipe size is not available, stick to the original pipe diameter (which may result in a small capacity decrease). [Gas side] RXYSQ4+5: → Ø15.9 Ø19.1 RXYSQ6: → Ø19.1 Ø22.2		A. Piping between outdoor unit and refrigerant branch kit • Match to the size of the connection piping on the outdoor unit. Outdoor unit connection piping size <table border="1"> <thead> <tr> <th rowspan="2">Outdoor unit capacity type</th> <th colspan="2">Piping size (outer diameter x minimum thickness)</th> </tr> <tr> <th>Gas pipe</th> <th>Liquid pipe</th> </tr> </thead> <tbody> <tr> <td>RXYSQ4+5</td> <td>Ø15.9x1.0 (Ø19.1x1.0)</td> <td rowspan="2">Ø9.5x0.8</td> </tr> <tr> <td>RXYSQ6</td> <td>Ø19.1x1.0 (Ø22.2x1.0)</td> </tr> </tbody> </table>		Outdoor unit capacity type	Piping size (outer diameter x minimum thickness)		Gas pipe	Liquid pipe	RXYSQ4+5	Ø15.9x1.0 (Ø19.1x1.0)	Ø9.5x0.8	RXYSQ6	Ø19.1x1.0 (Ø22.2x1.0)	B. Piping between refrigerant branch kits • Use the pipe size from the following table. <table border="1"> <thead> <tr> <th colspan="2">Piping size (outer diameter x minimum thickness)</th> </tr> <tr> <th>Gas pipe</th> <th>Liquid pipe</th> </tr> </thead> <tbody> <tr> <td>Ø15.9x1.0</td> <td>Ø9.5x0.8</td> </tr> </tbody> </table>	Piping size (outer diameter x minimum thickness)		Gas pipe	Liquid pipe	Ø15.9x1.0	Ø9.5x0.8
Outdoor unit capacity type	Piping size (outer diameter x minimum thickness)																			
	Gas pipe	Liquid pipe																		
RXYSQ4+5	Ø15.9x1.0 (Ø19.1x1.0)	Ø9.5x0.8																		
RXYSQ6	Ø19.1x1.0 (Ø22.2x1.0)																			
Piping size (outer diameter x minimum thickness)																				
Gas pipe	Liquid pipe																			
Ø15.9x1.0	Ø9.5x0.8																			
<p>1 Main pipe (enlarge) 2 First refrigerant branch kit 3 Indoor unit</p>		C. Piping between refrigerant branch kit and indoor unit • Pipe size for direct connection to indoor unit must be the same as the connection size of indoor unit. <table border="1"> <thead> <tr> <th rowspan="2">Indoor capacity index</th> <th colspan="2">Piping size (outer diameter x minimum thickness)</th> </tr> <tr> <th>Gas pipe</th> <th>Liquid pipe</th> </tr> </thead> <tbody> <tr> <td>20+25+32+40+50</td> <td>Ø12.7x08</td> <td>Ø6.4x0.8</td> </tr> <tr> <td>63+80+100+125</td> <td>Ø15.9x1.0</td> <td>Ø9.5x0.8</td> </tr> </tbody> </table>		Indoor capacity index	Piping size (outer diameter x minimum thickness)		Gas pipe	Liquid pipe	20+25+32+40+50	Ø12.7x08	Ø6.4x0.8	63+80+100+125	Ø15.9x1.0	Ø9.5x0.8						
Indoor capacity index	Piping size (outer diameter x minimum thickness)																			
	Gas pipe	Liquid pipe																		
20+25+32+40+50	Ø12.7x08	Ø6.4x0.8																		
63+80+100+125	Ø15.9x1.0	Ø9.5x0.8																		
How to calculate the additional refrigerant to be charged Additional refrigerant to be charged R (kg) R should be rounded o in units of 0.1 kg		$R = \left(\text{Total length (m) of liquid piping size at } \varnothing 9.5 \right) \times 0.054 + \left(\text{Total length (m) of liquid piping size at } \varnothing 6.4 \right) \times 0.022$		Example for refrigerant branch using refnet joint and refnet header <table border="1"> <tr> <td>a: Ø9.5x3 m</td> <td>d: Ø9.5x13 m</td> <td>g: Ø6.4x10 m</td> <td>j: Ø6.4x10 m</td> </tr> <tr> <td>b: Ø9.5x10 m</td> <td>e: Ø6.4x10 m</td> <td>h: Ø6.4x20 m</td> <td>k: Ø6.4x9 m</td> </tr> <tr> <td>c: Ø9.5x10 m</td> <td>f: Ø6.4x10 m</td> <td>i: Ø9.5x10 m</td> <td></td> </tr> </table> $R = [73 \times 0.054] + [69 \times 0.022] = 5.46 \Rightarrow 5.5 \text{ kg}$	a: Ø9.5x3 m	d: Ø9.5x13 m	g: Ø6.4x10 m	j: Ø6.4x10 m	b: Ø9.5x10 m	e: Ø6.4x10 m	h: Ø6.4x20 m	k: Ø6.4x9 m	c: Ø9.5x10 m	f: Ø6.4x10 m	i: Ø9.5x10 m					
a: Ø9.5x3 m	d: Ø9.5x13 m	g: Ø6.4x10 m	j: Ø6.4x10 m																	
b: Ø9.5x10 m	e: Ø6.4x10 m	h: Ø6.4x20 m	k: Ø6.4x9 m																	
c: Ø9.5x10 m	f: Ø6.4x10 m	i: Ø9.5x10 m																		

4PW66305-1

10 Installation

10 - 2 Refrigerant Pipe Selection

10

RXYSQ-P8Y1B

Example of connection
(Connection of 8 units heat pump system)

- indoor unit
- refrigerant branch kit (refnet joint)
- BP unit

NOTE The refrigerant branch kits must be positioned as close to the BP units as possible (c, d, e must be as short as possible).

Branch with refnet joint

Maximum allowable length	Between outdoor and BP units	Total pipe length	Pipe length between outdoor and BP units ≤55 m [Example] 3 BP units: a+b+c+d+e≤55 m
	Between BP and indoor units	Total pipe length	Piping length between BP and indoor units: RXYSQ4≤60 m, RXYSQ5≤80 m, RXYSQ6≤90 m [Example] RXYSQ5: f+g+h+i+j+k+l+m≤80 m
	Between BP and an indoor unit	1 room length	Pipe length between BP and an indoor unit: ≤15 m [Example] f, g, h, i, j, k, l, m≤15 m
Minimum allowable length(*)	Between outdoor unit and the first refrigerant branch kit	Pipe length	Pipe length between outdoor unit and first refrigerant branch kit: ≥5 m [Example] a≥5 m
	Between outdoor and indoor units	Difference in height	Difference in height between outdoor and indoor units (H1)≤30 m
Allowable height	Between outdoor and BP units	Difference in height	Difference in height between outdoor and BP units (H2)≤30 m
	Between BP and BP units	Difference in height	Difference in height between BP and BP units (H3)≤15 m
	Between indoor and indoor units	Difference in height	Difference in height between indoor and indoor units (H4)≤15 m
Allowable length after the branch		Pipe length	Pipe length from first refrigerant branch kit (refnet joint) to indoor unit ≤40 m [Example] unit 8: b+c+m≤40 m [Example] unit 6: b+e+k≤40 m [Example] unit 3: d+h≤40 m
	Refrigerant branch kit selection Refrigerant branch kits can only be used with R410A.		Use the following refnet joint: KHRQ22M20T.

(*) The refrigerant sound from the outdoor unit can be transmitted.

Pipe size selection

Symbol	Piping size (outer diameter x minimum thickness)		
	Gas pipe	Liquid pipe	
Between outdoor and first refrigerant branch kit	a	Ø19.1x1.0	
Between refrigerant branch kit and refrigerant branch kit	b	Ø15.9x1.0	
Between refrigerant branch kit and BP unit	c, d, e	Total indoor capacity Q	
		Qc, Qd, Qe ≤5.0 kW	Gas pipe: Ø12.7x0.8 Liquid pipe: Ø6.4x0.8
		Qc, Qd, Qe >5.0 kW	Gas pipe: Ø15.9x1.0 Liquid pipe: Ø9.5x0.8

NOTE

- Qc, Qd, Qe is total connected indoor capacity.
- c, d, e indicates the symbols in the figure.

Example

Indoor 4: 2.5 kW
Indoor 5: 3.5 kW
Indoor 6: 5.0 kW } Qe=11.0 kW

→ (Gas pipe) Ø15.9x1.0 and (liquid pipe) Ø9.5x0.8

How to calculate the additional refrigerant to be charged
Additional refrigerant to be charged R (kg)
R should be rounded off in units of 0.1 kg

$$R = \left(\text{Total length (m) of liquid piping size at } \varnothing 9.5 \right) \times 0.054 + \left(\text{Total length (m) of liquid piping size at } \varnothing 6.4 \right) \times 0.022$$

Example for refrigerant branch using refnet joint

a: Ø9.5x10 m	d: Ø9.5x10 m	g: Ø6.4x10 m	i: Ø6.4x10 m	m: Ø6.4x8 m
b: Ø9.5x10 m	e: Ø9.5x10 m	h: Ø6.4x10 m	k: Ø6.4x5 m	
c: Ø6.4x10 m	f: Ø6.4x10 m	j: Ø6.4x10 m	l: Ø6.4x5 m	

R=[40 x 0.054] + [78 x 0.022] = 3.876 ⇒ 3.9 kg

4PW66305-1

11 Operation range

11 - 1 Operation Range

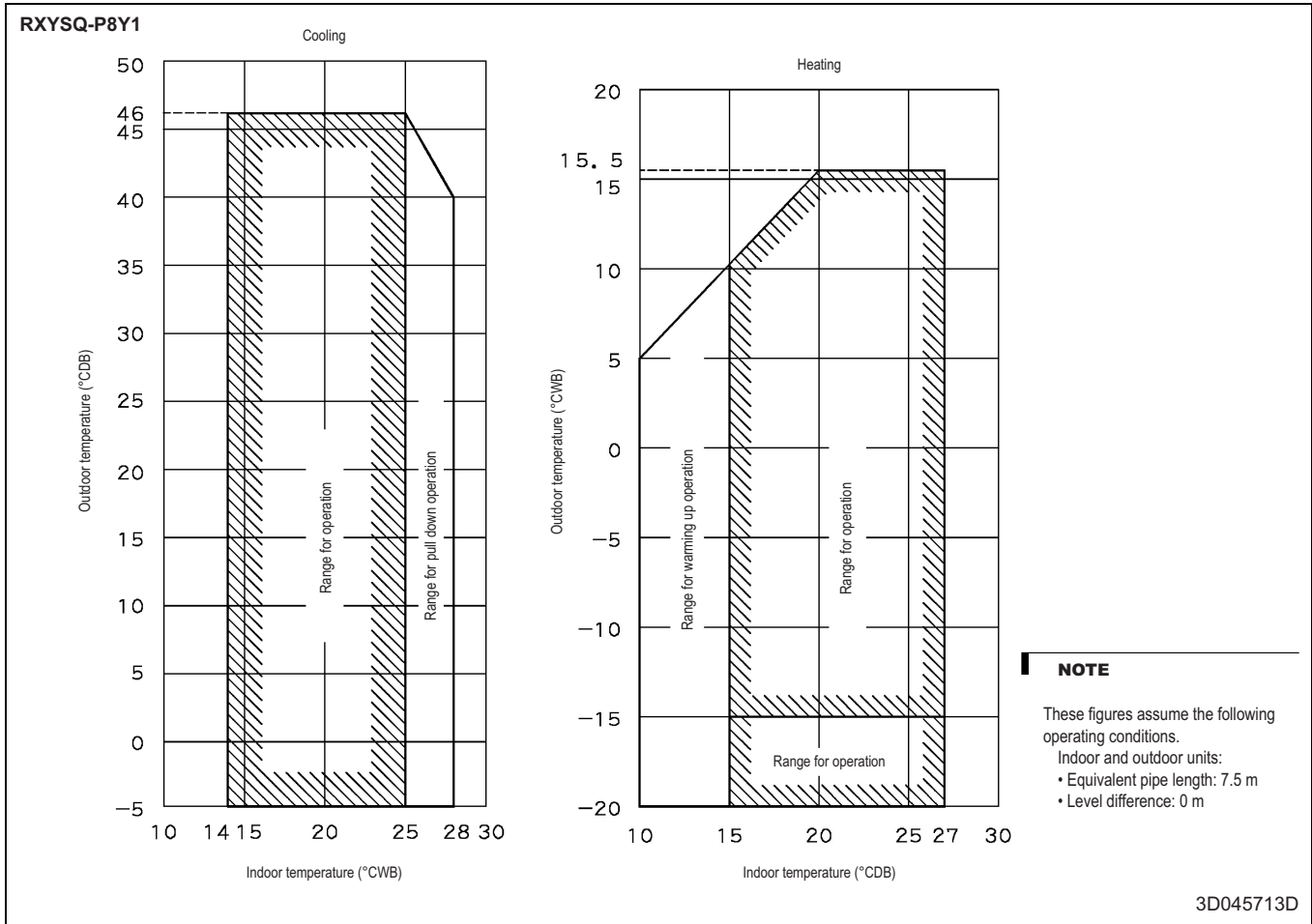

In all of us,
a green heart



Daikin's unique position as a manufacturer of air conditioning equipment, compressors and refrigerants has led to its close involvement in environmental issues. For several years Daikin has had the intention to become a leader in the provision of products that have limited impact on the environment. This challenge demands the eco design and development of a wide range of products and an energy management system, resulting in energy conservation and a reduction of waste.



VRV® products are not within the scope of the Eurovent certification programme.

The present publication is drawn up by way of information only and does not constitute an offer binding upon Daikin Europe N.V. Daikin Europe N.V. has compiled the content of this publication to the best of its knowledge. No express or implied warranty is given for the completeness, accuracy, reliability or fitness for particular purpose of its content and the products and services presented therein. Specifications are subject to change without prior notice. Daikin Europe N.V. explicitly rejects any liability for any direct or indirect damage, in the broadest sense, arising from or related to the use and/or interpretation of this publication. All content is copyrighted by Daikin Europe N.V.

Daikin products are distributed by: