



Air Conditioners

# Technical Data



Individual branch selector for VRV® heat recovery

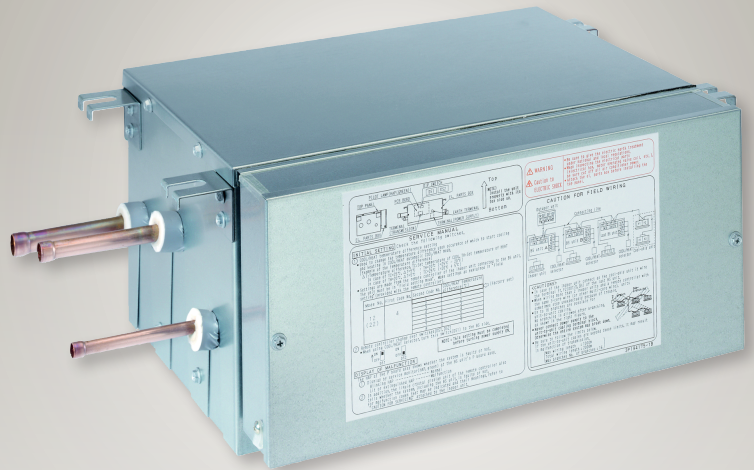

EEDEN12-200

BSVQ-P8



Air Conditioners

# Technical Data



Individual branch selector for VRV® heat recovery



EEDEN12-200

BSVQ-P8

# TABLE OF CONTENTS

## BSVQ-P8

1	Specifications .....	2
	Technical Specifications .....	2
	Electrical Specifications .....	2
2	Safety device settings .....	3
	Safety Device Settings .....	3
3	Options .....	4
	Options .....	4
4	Dimensional drawings .....	5
	Dimensional Drawings .....	5
5	Centre of gravity .....	7
	Centre of Gravity .....	7
6	Piping diagrams .....	8
	Piping Diagrams .....	8
7	Wiring diagrams .....	9
	Wiring Diagrams - Single Phase .....	9
8	Sound data .....	10
	Sound Pressure Spectrum .....	10

# 1 Specifications

1

1-1 Technical Specifications				BSVQ100P8	BSVQ160P8	BSVQ250P8
Power input	Cooling	Nom.	kW	0.005		
	Heating	Nom.	kW	0.005		
Maximum number of connectable indoor units				6	8	
Maximum capacity index of connectable indoor units				15<x≤100	100<x≤160	160<x≤250
Casing	Material			Galvanised steel plate		Galvanised steel
Dimensions	Unit	HeightxWidthxDepth	mm	207x388x326		
Weight	Unit			kg	12	15
Piping connections	Outdoor unit	Liquid	Type	Brazing connection		
			OD	mm	9.5	
		Gas	Type	Brazing connection		
			OD	mm	15.9	15.9 (1)
		Discharge gas	Type	Brazing connection		
			OD	mm	12.7	12.7 (1)
	Indoor unit	Liquid	Type	Brazing connection		
			OD	mm	9.5 (1)	9.5
		Gas	Type	Brazing connection		
			OD	mm	15.9 (1)	
Sound absorbing thermal insulation				Foamed polyurethane, frame resisting needle felt		

Standard Accessories : Clamps;

Standard Accessories : Insulation pipe cover;

Standard Accessories : Attached piping;

Standard Accessories : Installation manual;

1-2 Electrical Specifications				BSVQ100P8	BSVQ160P8	BSVQ250P8
Power supply	Phase			1~		
	Voltage			V		
	Voltage range	Min.	%	-10		
		Max.	%	10		
Total circuit	Minimum circuit amps (MCA)		A	0.1		
	Maximum fuse amps (MFA)		A	15		
Notes				Instead of a fuse, use a circuit breaker		

## Notes

- (1) In case of connection with a 20~50 type indoor unit, match to the size of the field pipe using the attached pipe. Connection between the attached pipe and the field pipe must be brazed.
- (2) Voltage range: units are suitable for use on electrical systems where voltage supplied to unit terminal is not below or above listed range limits.
- (3) Maximum allowable voltage range variation between phases is 2%.
- (4) MCA/MFA: MCA = 1.25 x FLA
- (5) MFA ≤ 4 x FLA
- (6) Next lower standard fuse rating minimum 15A
- (7) Select wire size based on the value of MCA
- (8) Instead of a fuse, use a circuit breaker
- (9) In case of connecting with indoor unit capacity index between 150 and 160, match to the size of the field pipe using the attached pipe. Connection between the attached pipe and the field pipe must be brazed.
- (10) In case of connecting with a 200 type indoor unit or capacity index more than 160 and less than 200, match to the size of the field pipe using the attached pipe. Connection between the attached pipe and the field pipe must be brazed.

2

## 2 Safety device settings

### 2 - 1 Safety Device Settings

BSVQ-P8	
Model	Safety devices
	PC board fuse
BSVQ100PV1	250V 3.15A
BSVQ160PV1	250V 3.15A
BSVQ250PV1	250V 3.15A
BSVQ36PVJU	250V 3.15A
BSVQ60PVJU	250V 3.15A
BSVQ96PVJU	250V 3.15A

4D057956B

### 3 Options

#### 3 - 1 Options

**BSVQ-P8**

**OPTION LIST**

No	Item	BSVQ100P	BSVQ160P	BSVQ250P
1	PCB for multi tenant	DTA114A61		
2	Sound reduction for BSVQ box	EKBSVQLNP (see note 2)		

4TW31159-1A

**NOTE**

- 1 All options are kits.
- 2 Only available for standard BSVQ boxes (not possible for central BSV4Q).  
Allows to reduce operating sound of BSVQ-box (requires 1 sound kit per BSVQ-box).

3

## 4 Dimensional drawings

### 4 - 1 Dimensional Drawings

**BSVQ100P8B**

Nr	Name	Description
1	Suction gas pipe connection port	ø15.9mm brazing connection
2	HP/LP gas pipe connection port	ø12.7mm brazing connection
3	Liquid pipe connection port	ø9.5mm brazing connection
4	Gas pipe connection port	ø15.9mm brazing connection
5	Liquid pipe connection port	ø9.5mm brazing connection
6	Electric box (note 1.)	
7	Suspension brackets	M8 ~M10
8	Grounding terminal	M4
9	Attached pipe (1) (Note. 3)	ø12.7mm brazing connection
10	Attached pipe (2) (Note. 3)	ø6.4mm brazing connection

**NOTES**

- Electric box can also be fixed on the other side of the unit.
- Be sure to install an inspection door at electric box side.
- Attached pipe is only used in case of connecting with a 20-50 class indoor unit.
- Small sound of refrigerant will be made, which may be disturbing.  
Do not install it at the place such as bedroom under roof.

3D056011

**BSVQ160P8B**

Nr	Name	Description
1	Suction gas pipe connection port	ø15.9mm brazing connection
2	HP/LP gas pipe connection port	ø12.7mm brazing connection
3	Liquid pipe connection port	ø9.5mm brazing connection
4	Gas pipe connection port	ø15.9mm brazing connection
5	Liquid pipe connection port	ø9.5mm brazing connection
6	Electric box (note 1.)	
7	Suspension brackets	M8 ~M10
8	Grounding terminal	M4
9	Attached pipe (1) (Note. 3)	ø19.1mm brazing connection
10	Attached pipe (2) (Note. 3)	ø15.9mm brazing connection

**NOTES**

- Electric box can also be fixed on the other side of the unit.
- Be sure to install an inspection door at electric box side.
- Attached pipe is only used in case of connecting with indoor unit capacity index 150 or more and 160 or less.
- Small sound of refrigerant will be made, which may be disturbing.  
Do not install it at the place such as bedroom under roof.

3D058004

## 4 Dimensional drawings

### 4 - 1 Dimensional Drawings

BSVQ250P8B

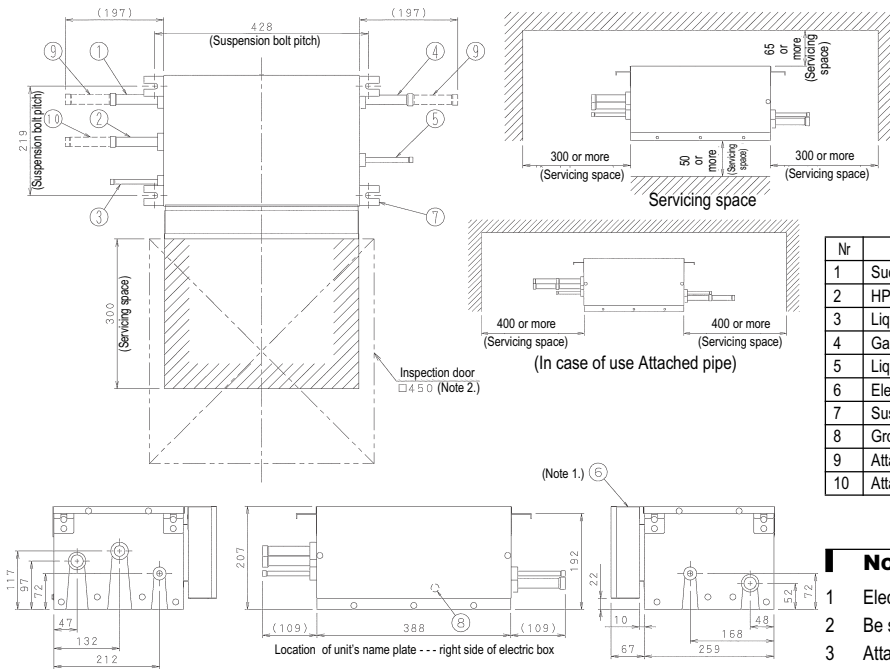

Nr	Name	Description
1	Suction gas pipe connection port	ø22.2mm brazing connection
2	HP/LP gas pipe connection port	ø19.1mm brazing connection
3	Liquid pipe connection port	ø9.5mm brazing connection
4	Gas pipe connection port	ø22.2mm brazing connection
5	Liquid pipe connection port	ø9.5mm brazing connection
6	Electric box (note 1.)	
7	Suspension brackets	M8 ~M10
8	Grounding terminal	M4
9	Attached pipe (1) (Note. 3)	ø19.1mm brazing connection
10	Attached pipe (2) (Note. 3)	ø15.9mm brazing connection

#### NOTES

- 1 Electric box can also be fixed on the other side of the unit.
- 2 Be sure to install a inspection door at electric box side.
- 3 Attached pipe (1) and attached pipe (2) is used in case of connecting with indoor capacity index more than 160 and less than 200 In case of connecting one indoor unit of 200 type, only gas pipe connection port need Attached pipe (1).
- 4 Small sound will be made when changing over the motor operated valve, which may be disturbing. Do not install it at the place such as bedroom under roof.

3D056012A



## 5 Centre of gravity

### 5 - 1 Centre of Gravity

#### BSVQ100,160P8B

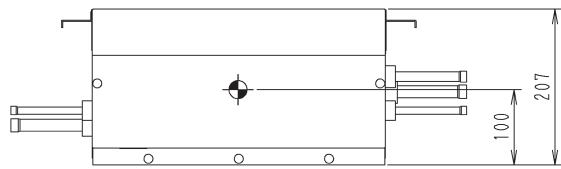
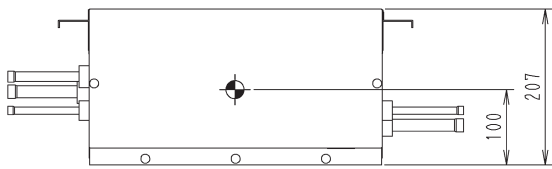
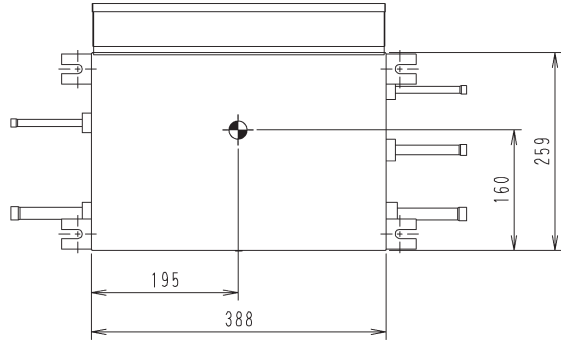
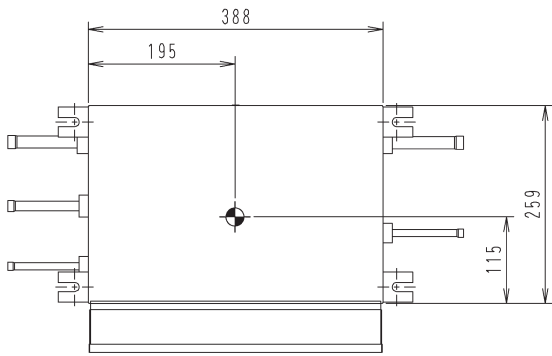

In case of the electrical box on the standard side of the unit

In case of the electrical box on the other side of the unit

3D058131

#### BSVQ250P8B

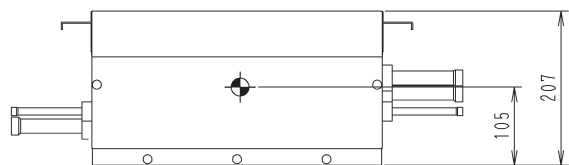
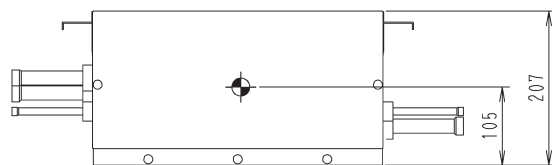
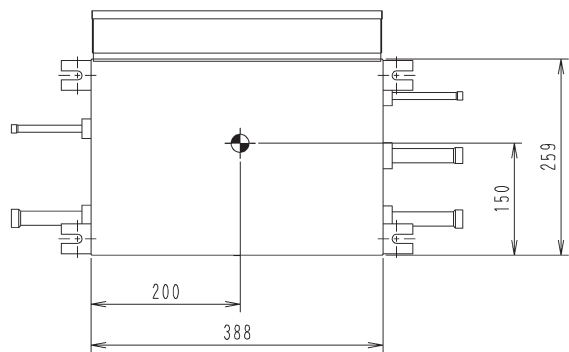
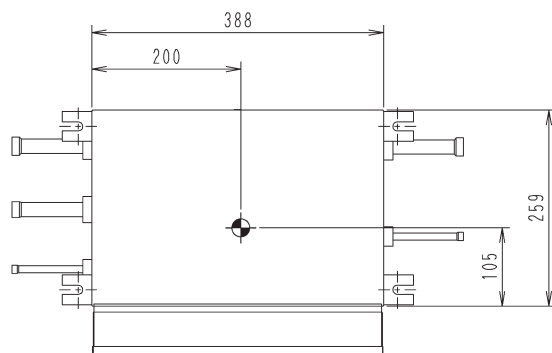

In case of the electrical box on the standard side of the unit

In case of the electrical box on the other side of the unit

3D058132

## 6 Piping diagrams

### 6 - 1 Piping Diagrams

BSVQ-P8

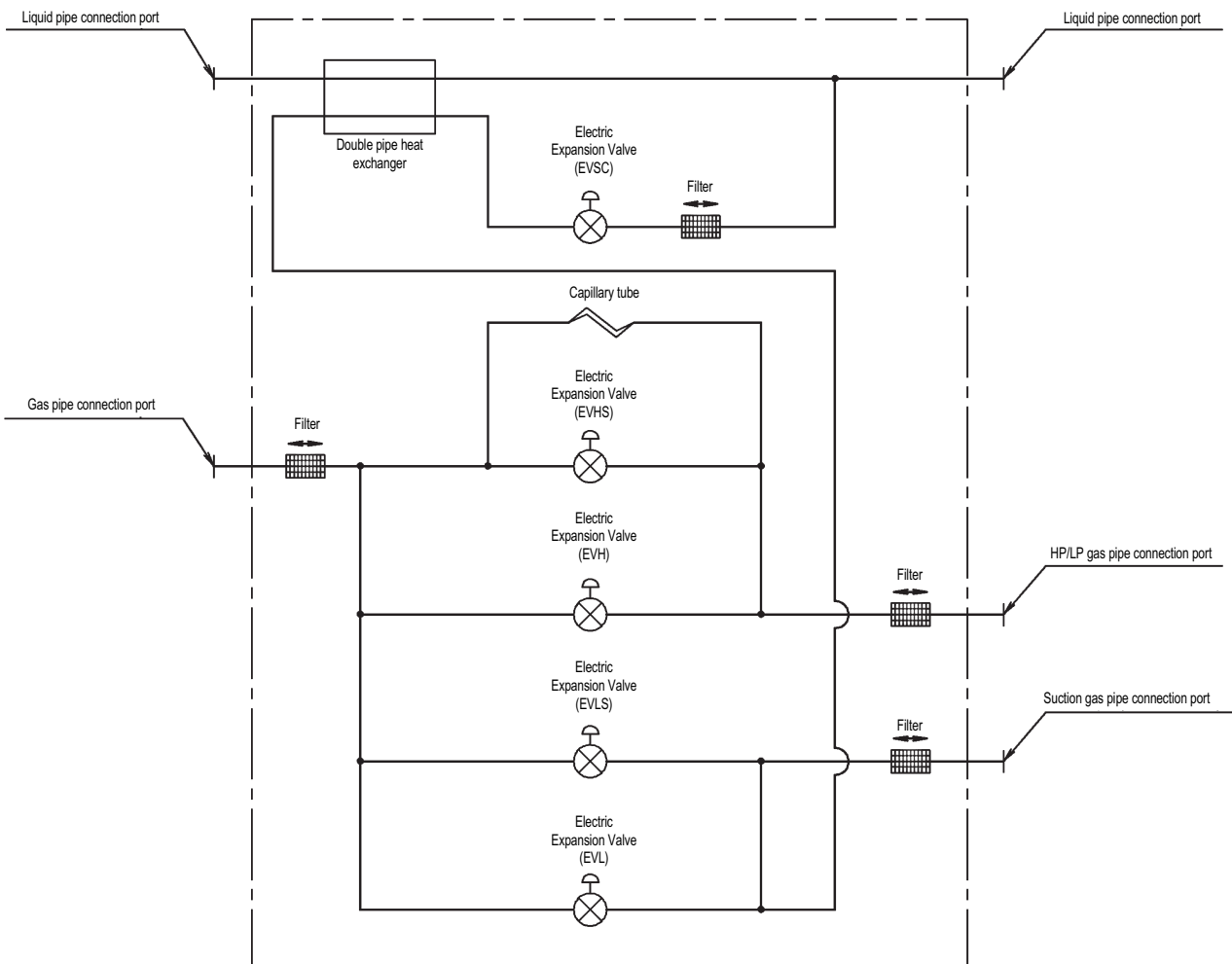

4D057985B

# 7 Wiring diagrams

## 7 - 1 Wiring Diagrams - Single Phase

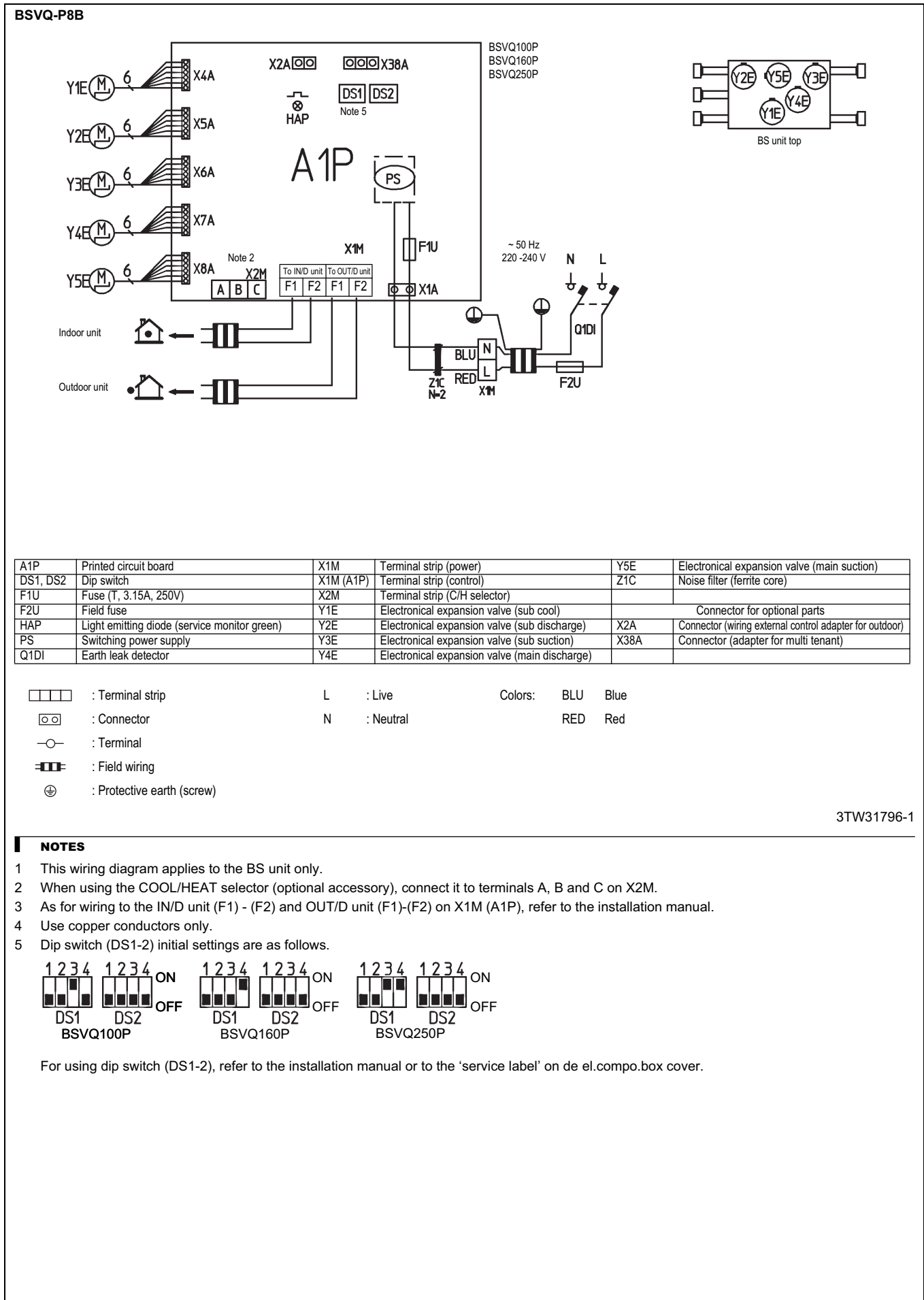

# 8 Sound data

## 8 - 1 Sound Pressure Spectrum

8

**BVSQ100P8B**

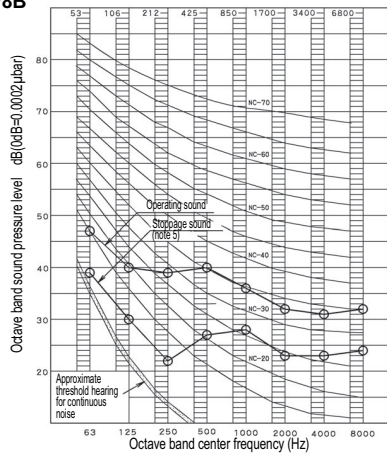

4D058945

**NOTE**

- Over All (dB): (B, G, N is already rectified)
- Operating conditions:
  - Power source: 220-240V 50Hz
  - Standard condition (JIS)
- Measuring place: Anechoic chamber.
- Operation noise differs with operation and ambient conditions.
- In case of other unit operating in the same system, operating sound will be generated, ever if indoor unit connected to BS unit is stopped.
- Location of microphone.

Scale	Operation sound	Stoppage sound
A	42	32
C	49	40

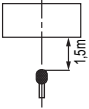

**BVSQ160P8B**

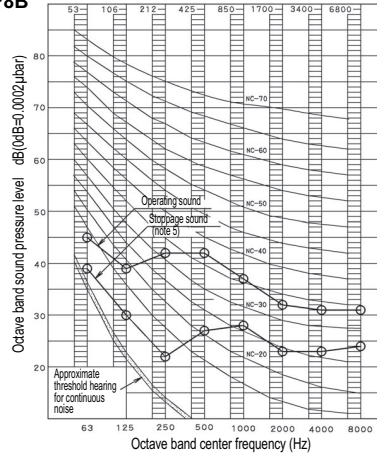

4D058953

**NOTE**

- Over All (dB): (B, G, N is already rectified)
- Operating conditions:
  - Power source: 220-240V 50Hz
  - Standard condition (JIS)
- Measuring place: Anechoic chamber.
- Operation noise differs with operation and ambient conditions.
- In case of other unit operating in the same system, operating sound will be generated, ever if indoor unit connected to BS unit is stopped.
- Location of microphone.

Scale	Operation sound	Stoppage sound
A	43	32
C	49	40

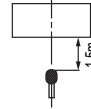

**BVSQ250P8B**

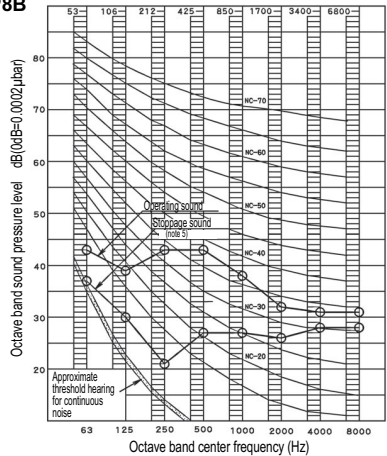

4D058946

**NOTE**

- Over All (dB): (B, G, N is already rectified)
- Operating conditions:
  - Power source: 220-240V 50Hz
  - Standard condition (JIS)
- Measuring place: Anechoic chamber.
- Operation noise differs with operation and ambient conditions.
- In case of other unit operating in the same system, operating sound will be generated, ever if indoor unit connected to BS unit is stopped.
- Location of microphone.

Scale	Operation sound	Stoppage sound
A	44	34
C	49	39

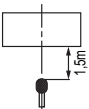

In all of us,  
a green heart



Daikin's unique position as a manufacturer of air conditioning equipment, compressors and refrigerants has led to its close involvement in environmental issues. For several years Daikin has had the intention to become a leader in the provision of products that have limited impact on the environment. This challenge demands the eco design and development of a wide range of products and an energy management system, resulting in energy conservation and a reduction of waste.

VRV® products are not within the scope of the Eurovent certification programme.



The present publication is drawn up by way of information only and does not constitute an offer binding upon Daikin Europe N.V. Daikin Europe N.V. has compiled the content of this publication to the best of its knowledge. No express or implied warranty is given for the completeness, accuracy, reliability or fitness for particular purpose of its content and the products and services presented therein. Specifications are subject to change without prior notice. Daikin Europe N.V. explicitly rejects any liability for any direct or indirect damage, in the broadest sense, arising from or related to the use and/or interpretation of this publication. All content is copyrighted by Daikin Europe N.V.

Daikin products are distributed by:

