



Ventilation

Technical Data

Heat Reclaim Ventilation



EEDEN11-205

VAM-FA

Ventilation

Technical Data

Heat Reclaim Ventilation



EEDEN11-205

VAM-FA

TABLE OF CONTENTS

VAM-FA

1	External appearance	3
2	Model series	3
3	Nomenclature	3
4	Structures	4
5	Features	5
	Interlocked operation with VRV (SkyAir)	5
	Energy Saving	6
	FRESH-UP operation	7
	Easy Installation and service maintenance	8
6	Selection Procedures	9
	Based on inhabitants	9
	Based on Room size	10
	Based on Room size	11
7	Product Specification	12
	Technical Specifications	12
	Electrical Specifications	14
	Optional accessories	15
	The correction ratio of exchange efficiency	84
	Dimensions	85
	Wiring diagram	90
	Sound level data	92
	Fan performance	98
	Installation method	100
8	Operation	105
	Method of operation	105
	Cautions in use	107
	Maintenance	108
9	Control System	109
	Introduction of control system	109
	Basic patterns	110
	Applicable patterns	120
	Functions of Printed Circuit Board	130
	Fan operation setting	131
	Operation mode change over	132

10	Installation	133
	Reducing operating sound	133
	Centralized piping	135
	Cautions	136
	Cautions in installation	138
	Duct Work	139
	Electrical wiring procedure	140
	Initial setting	143

1 External appearance



VAM150FA



VAM250FA



VAM350FA



VAM500FA



VAM650FA



VAM800FA



VAM1000FA

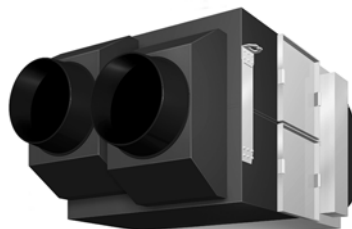

VAM1500FA

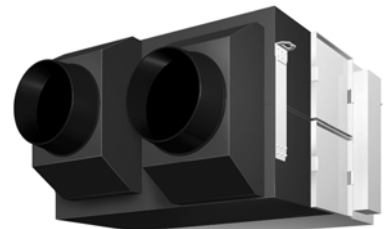

VAM2000FA

2 Model series

- VAM150FA
- VAM250FA
- VAM350FA
- VAM500FA
- VAM650FA
- VAM800FA
- VAM1000FA
- VAM1500FA
- VAM2000FA

3 Nomenclature

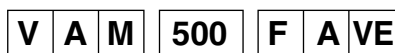

- Ventilation
- Air
- Mounted type
- Air flow rate (m³/h)
- Major design category
- Design category for EC application
- Power supply
 - VE: Single phase 50 Hz 220 – 240 V,
 - 60 Hz 220 V

(HC0001)

4 Structures

VAM150-1000FA

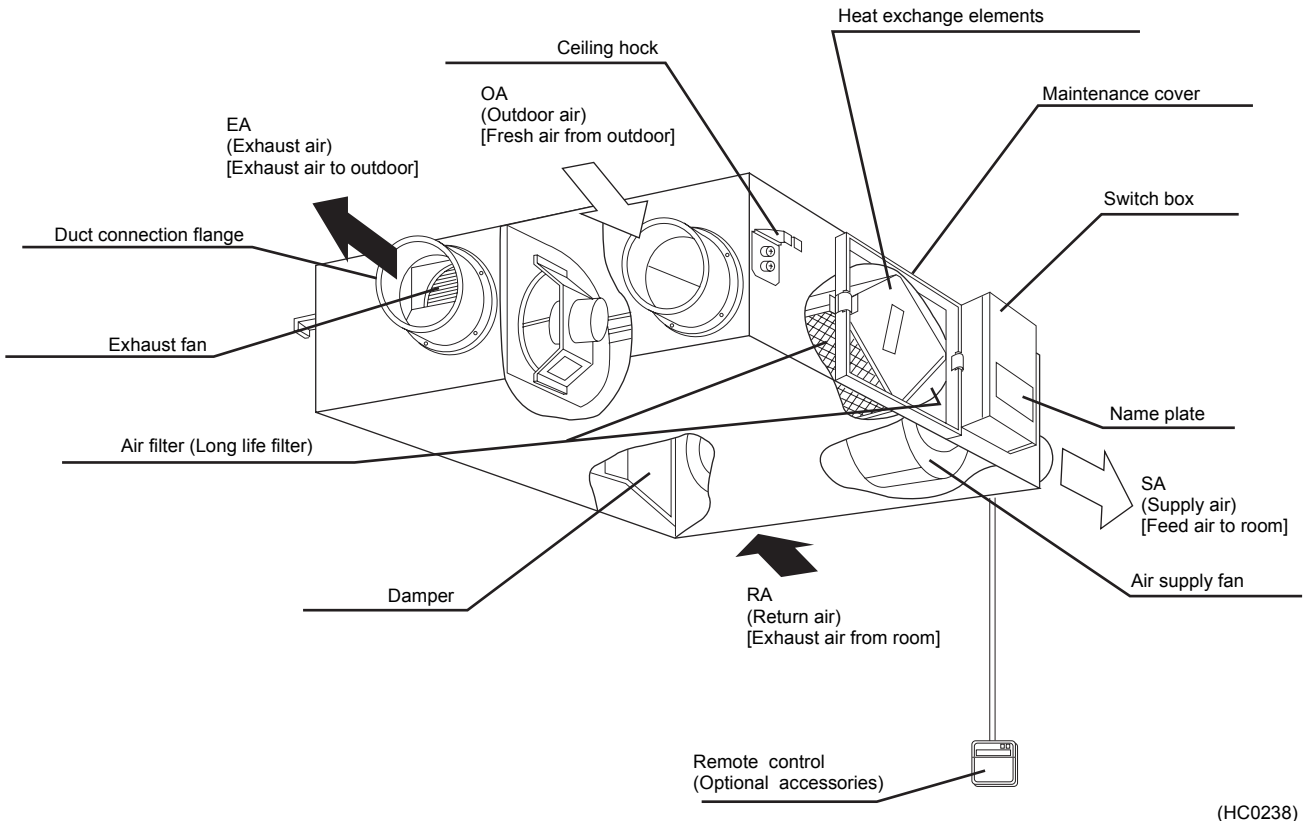

VAM1500,2000FA

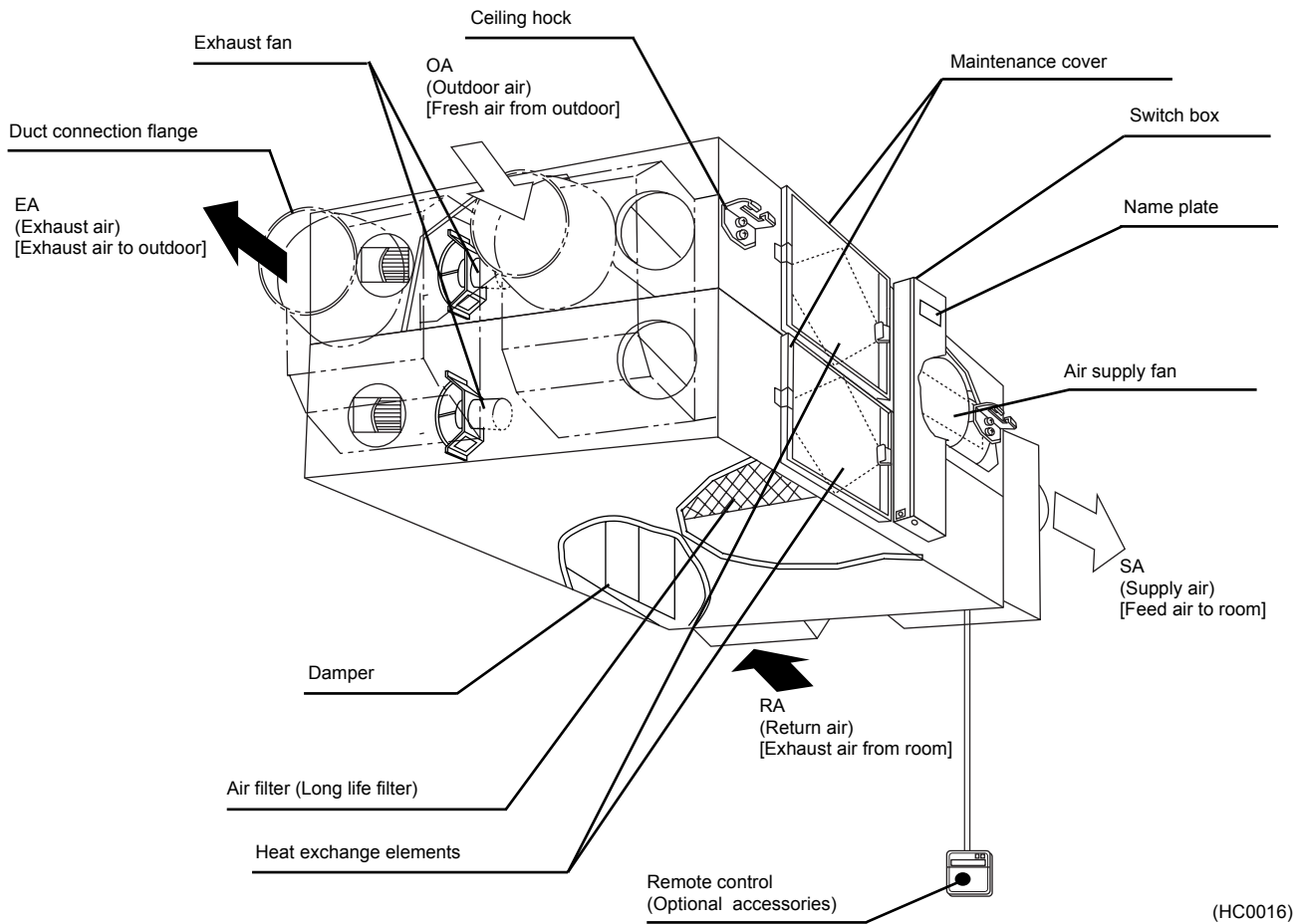

5 Features

5 - 1 Interlocked operation with VRV (SkyAir)

1. Simultaneous ON / OFF with the indoor unit by the indoor unit remote control.
2. HRV independent operation during air conditioning off season by the indoor unit remote control.
3. Automatic ventilation mode changeover: Auto / Heat Recovery / Bypass
4. Fan speed changeover by the indoor unit remote control: High / Low, Ultra-High / High, Ultra-High / Low
5. Precooling / heating control function setting to delay the start of ventilation during air conditioner start-up to realize the high energy saving efficiency.
6. FRESH-UP operation setting
7. Filter sign display notifies the time for cleaning the filter
8. No need to purchase or install the HRV exclusive remote control
9. Advantage to IAQ (Internal Air Quality.)

Note:

1. 5-7 can be set at the initial setting only.

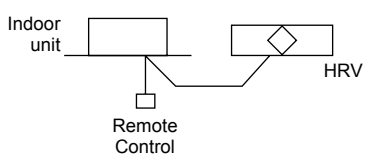
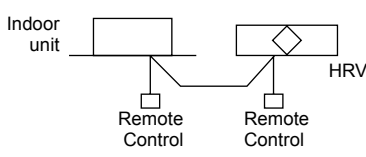
Type	Interlocked operation with air conditioner	HRV independent operation
Structure	 <p>(HC0228)</p>	 <p>(HC0229)</p>
Features	<ul style="list-style-type: none"> • Simultaneous operation by air conditioner's remote control is available • Fan speed can be set at the initial setting. 	<ul style="list-style-type: none"> • Both simultaneous operation by air conditioner's remote control and independent operation by HRV exclusive remote control are available • Fan speed can be changed by switch of HRV (High / Low, High / Ultra-high, Low / Ultra-high)
Connectable Indoor unit	VRV (all indoor unit), SkyAir (Optional connecting PCB is required.)	

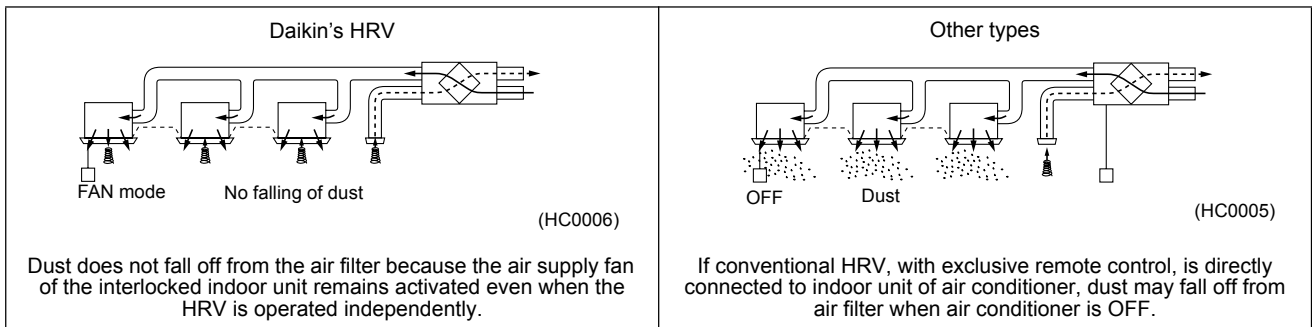

Installation Examples

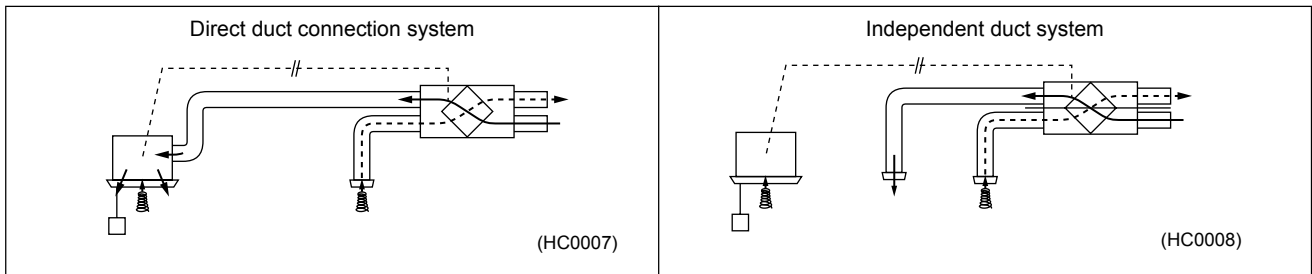

5 Features

5 - 2 Energy Saving

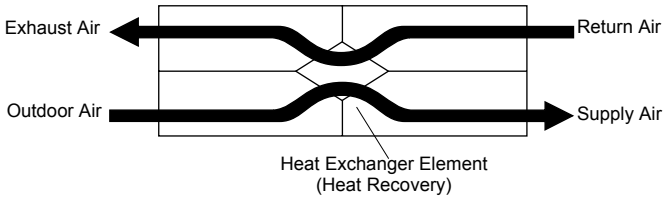
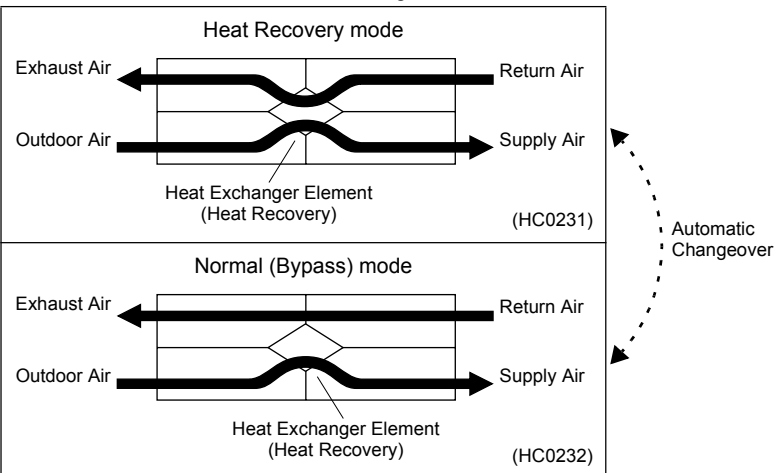
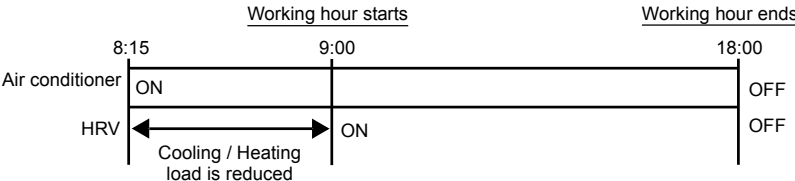
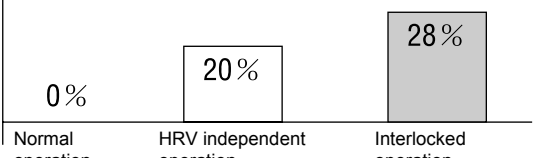
<p>By heat recovery operation</p> <p>Approx. 20% reduction of heating / cooling load</p> <p>+</p>	<p>HRV unit recovers the thermal energy during cooling / heating operation of air conditioner. HRV reduces the cooling / heating load drastically and enhances the heating / cooling efficiency.</p>  <p style="text-align: right;">(HC0230)</p>									
<p>By setting to automatic ventilation mode</p> <p>Approx. 6% reduction of heating / cooling load</p> <p>+</p>	<p>Proper use of Heat recovery ventilation and normal ventilation saves energy. When the cooling operation is required in winter, use of heat recovery ventilation is not efficient because the outdoor air temperature is normally lower than that of the indoor. Thus, the proper use of ventilation mode enhances the heating / cooling efficiency.</p> <p>Automatic Ventilation mode changeover</p> <table border="1" data-bbox="635 694 1417 896"> <thead> <tr> <th>Operation</th> <th>Sensor of ventilation Difference between indoor / outdoor temp.</th> <th>Decision of mode (Which is more energy efficient?)</th> </tr> </thead> <tbody> <tr> <td>Cooling</td> <td>Indoor temp. > Outdoor temp. Indoor temp. < Outdoor temp.</td> <td>Normal ventilation (Bypass) Heat recovery ventilation</td> </tr> <tr> <td>Heating</td> <td>Indoor temp. > Outdoor temp. Indoor temp. < Outdoor temp.</td> <td>Heat recovery ventilation Normal ventilation (Bypass)</td> </tr> </tbody> </table> <p>Refer to the CONTROL for the mode changeover.</p> 	Operation	Sensor of ventilation Difference between indoor / outdoor temp.	Decision of mode (Which is more energy efficient?)	Cooling	Indoor temp. > Outdoor temp. Indoor temp. < Outdoor temp.	Normal ventilation (Bypass) Heat recovery ventilation	Heating	Indoor temp. > Outdoor temp. Indoor temp. < Outdoor temp.	Heat recovery ventilation Normal ventilation (Bypass)
Operation	Sensor of ventilation Difference between indoor / outdoor temp.	Decision of mode (Which is more energy efficient?)								
Cooling	Indoor temp. > Outdoor temp. Indoor temp. < Outdoor temp.	Normal ventilation (Bypass) Heat recovery ventilation								
Heating	Indoor temp. > Outdoor temp. Indoor temp. < Outdoor temp.	Heat recovery ventilation Normal ventilation (Bypass)								
<p>By Precooling / heating operation</p> <p>Approx. 2% reduction of heating / cooling load</p> <p> </p>	<p>The load is reduced at startup of the air conditioner by the following control. Before the working hour, the room air is clean. Therefore, the startup of HRV can be delayed.</p> 									
<p>Total 28% reduction of heating / cooling load</p>	<p>Reduction of heating / cooling load (%)</p>  <p style="text-align: right;">(HC0233)</p>									

Note:

1. The total heating / cooling load may vary depending on the climate or the other environmental conditions.

5 Features

5 - 3 FRESH-UP operation

Both the excessive supply mode and the excessive exhaust mode are selectable. This function creates a more comfortable air environment.

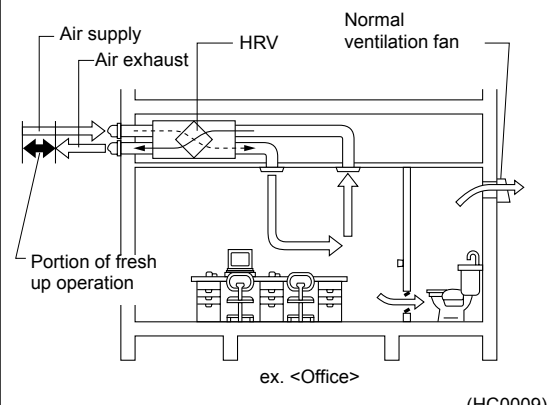
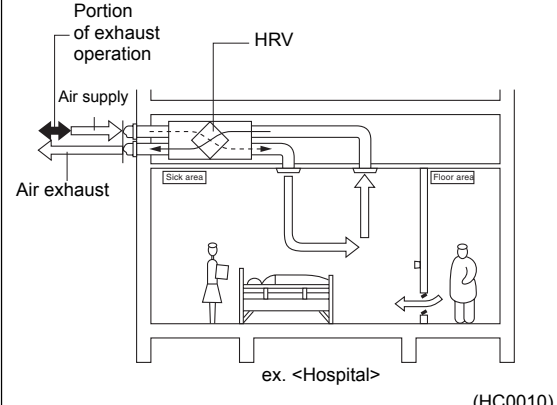
	Supply Fresh-up (Excessive outdoor air supply)	Exhaust Fresh-up (Excessive Exhaust air supply)
Detail	Supply air volume can be set at a higher level than the exhaust air by the remote control.	Exhaust air volume can be set at a higher level than the supply air by the remote control.
Major effects	<ul style="list-style-type: none"> Prevents inflow of toilet odor Prevents inflow of outdoor air in winter 	<ul style="list-style-type: none"> Prevents outflow of airborne bacteria from rooms in a hospital Prevents outflow of odors from rooms in a nursing home
Application	Offices, etc.	Hospitals, Nursing homes, etc.
Example		

5 - 4 Element (HEP element)

Material

The heat exchanger element adopts a new paper of high permeability. The material recovers exhaust humidity at a speed of 2 times of the previous model.

The material is flame-retardant for safety.

The fungiproof design also keeps the air clean.

Structure

The heat exchanger element is designed without moving parts for higher durability and reliability.

The supply air passage and the exhaust air passage are arranged in right angle to prevent the supply and exhaust air from getting mixed.



(HC0013)

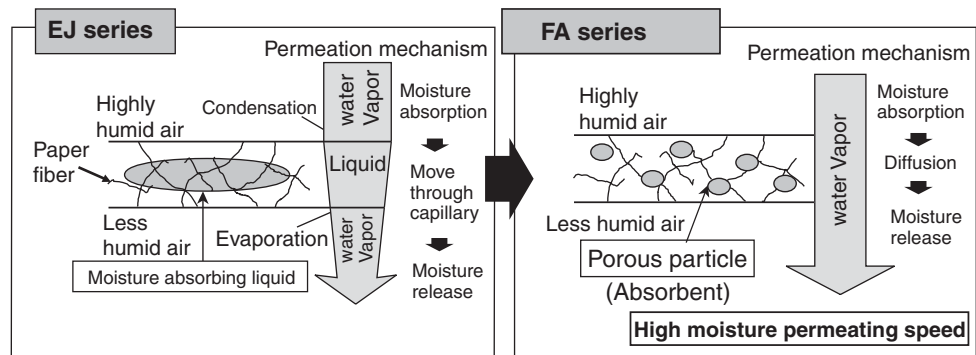

5 Features

5 - 5 Easy Installation and service maintenance

Downsized

Total volume is reduced to 68% of EJ series and the unit fits into a small space.

(Comparison with FJ and previous EJ series)

Model name	Height		Height Difference (mm)	Volume compared with EJ series
	FJ	EJ		
VAM 500FA	285 ←	310	-25	68%
VAM 800FA	348 ←	388	-40	70%
VAM1000FA	348 ←	388	-40	78%
VAM2000FA	710 ←	790	-80	82%

Parallel air flow system (Daikin)

This system prevents misconnection and simplify the installation work.

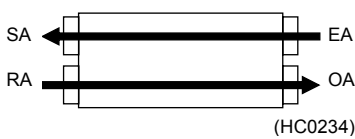

Cross air flow system

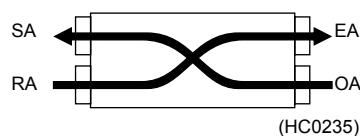

Service Maintenance

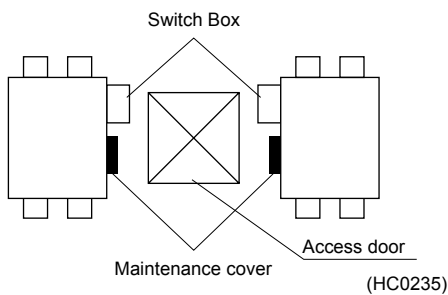

Upside-down installation is available.

It allows the common use of the access door and reduces the space and installation work.

For 2 units closely installed, only one inspection hole of 450 × 450 mm will do for maintenance or replacement of the heat exchanger element etc.

Long life filter is equipped.

5 - 6 Additional Optional accessories compared with EJ Series

Built-in optional high efficiency filter

It greatly reduces the installation space.

The installation of access doors and the unit can be reduced.

Direct expansion coil

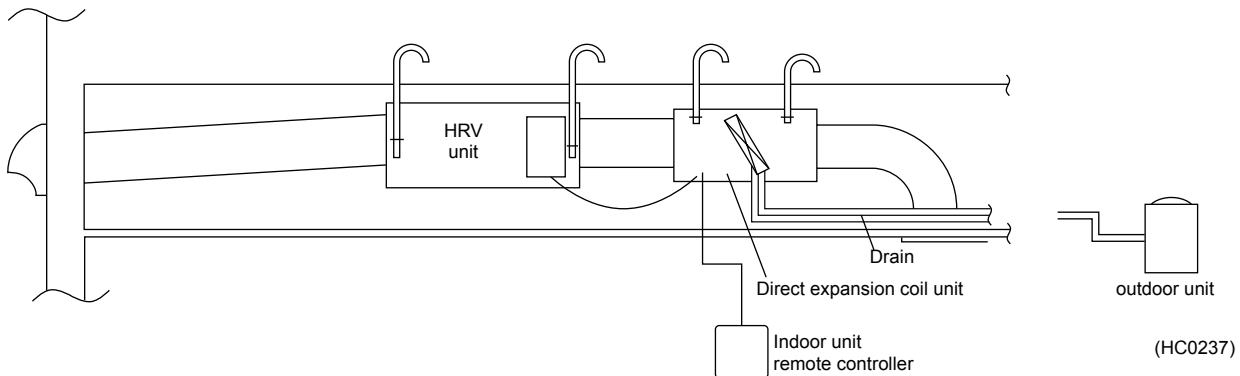

The direct expansion coil helps to recover approx. 100% of exhaust air heat and prevents unpleasant draft. It can also operate as an air conditioner.

Connectable unit: VRV and HRV.

BRP4A50

Refer to 6.16 Heater control kit (page 145) for the detail.

6 Selection Procedures

Various methods are used to calculate the required ventilating airflow rate according to CO₂ generated by inhabitants in a room, waste gas generated by use of fire, and other conditions of a room. Here are 2 patterns of calculating methods.

6 - 1 Based on inhabitants

$$\text{Required ventilating air flow rate (m}^3/\text{h)} = \frac{20 \times A}{B}$$

A: 20 × Living room floor space (m²)
 B: Area occupied per person (m²)

The above equation conforms to article 20, 2 No.2 of the Building Standards Act in Japan.

- 20 (in the above equation) means “20(m³ / h / person)”, which is the required ventilating air flow rate based on the CO₂ exhausted by an adult sitting still in a room. If smoking is allowed, other calculation method should be used.
- Use 10 (m²) if the area occupied per person exceeds 10 (m²).

<Table 1>

Type of building	Area occupied per person (N)	Remarks
Eating houses, restaurants, coffee-shops	3 m ²	Floor space of a part used for business purposes.
Cabarets, beer halls	2 m ²	Floor space of a part used for business purposes.
Japanese-style restaurants, hall for hire	3 m ²	Floor space of a part used for business purposes.
Store market	3 m ²	Floor space of a part used for business purposes.
Pool rooms, Ping-pong rooms, dance halls, bowling alleys	2 m ²	Floor space of a part used for business purposes.
Pin-ball parlors, Go club houses, mahjong parlors	2 m ²	Floor space of a part used for business purposes.
Inns, hotels, and motels	10 m ²	Floor space of a part used for business purposes.
Massage parlors	5 m ²	Floor space of a part used for business purposes.
Meeting places, public halls	0.5 – 1 m ²	Persons accommodated simultaneously with the number of persons calculated per unit.
Offices	5 m ²	Floor space of an office.

*: Values set by the Metropolitan Maintenance Bureau in Japan.

Note:

- Table indicates the required ventilating air flow rate calculated as 20 m³ / h.
- The area occupied per person by type of business is calculated in reference to Application Standards for building administration in compliance with Building Standards Act in Japan.

6 - 2 Based on Room size

$$\text{Required ventilating air flow rate (m}^3/\text{h)} = C \times D \times E$$

C: Number of ventilation required per hour (ventilation / h)
 D: Area of room (m²) (See Table 3 of the following page)
 E: Height of Ceiling (m) (See table 2)

Calculation is based on the experiences of hygienic laboratory, etc. to find out the number of hourly ventilation of the room air.

(Selection example)

Place: Living room of common household
 Required ventilation: 6 times / h (See table 2)
 Area of room: Approx. 9.9 (m²)
 Height of ceiling: 2.4 m
 Required ventilating air flow rate =
 $6 \times 9.9 \times 2.4 = 143 \text{ (m}^3/\text{h)}$

Required ventilating air flow rate and the unit size such as 150, 250, 3502000 are almost equal. So select the close size of the unit. In this case, select VAM150FJVE.

<Table 2>

Groups	Type of room	Ventilation required	Groups	Type of room	Ventilation required
Common household	Living room,	6	Playhouses and movie theaters	Audience room,	6
	bathroom,	6		corridor,	6
	drawing room,	6		smoking room,	12
	toilet,	10		toilet,	12
	kitchen	15		projector room	20
Eating places	Restaurant, sushi restaurant,	6	Plants	Office room,	6
	banquet hall,	6		general work room,	6
	tempura restaurant,	10		telephone room,	6
	cooking room	20		spinning plant,	10
		20		printing plant,	10
Inns and hotels	Guest room,	5		battery room,	10
	corridor,	5		machinery plant,	10
	dance hall,	8		generator room,	15
	large dining hall,	8		substation room,	15
	washroom, toilet,	10		painting shop,	15
	cooking room,	15	welding plant,	15	
	laundry room,	15	chemical plant,	15	
	engine room,	20	food plant,	20	
	boiler room	20	wood working plant,	20	
			casting plant	50	
Hospitals	Consultation office,	6	General buildings	Office room,	6
	sick room,	6		waiting room,	10
	office room,	6		show room, toilet,	10
	corridor,	10	conference room	12	
	waiting room,	10	Comfort stations		20
	bathroom,	10		Dark rooms	Dark rooms for photo
	dining room, toilet,	10	Guest rooms of ship		
	respiratory disease room,	10		Room of potential noxious gas or combustible gas	
	laundry room,	15			
	cooking room,	15			
surgery room,	15				
sterilizing room,	15				
engine room,	20				
boiler room	20				
Schools	Class room,	6			
	library, auditorium,	6			
	experimental chemistry room,	6			
	gymnasium,	8			
	toilet,	12			
cooking room	15				

Note:

Refer to the following pages for the tables.

6 Selection Procedures

6 - 2 Based on Room size

<Table 3> Criteria for Model Selection

Required ventilating AFR per person (m ³ / h / person)	Area per person (m ² / person)	Model Name	Frequency	Air Flow Rate		Application area (m ²)
			Hz	L	H	
20	3	VAM150FA	50	110	150	16.5 – 22.5
			60	110	150	16.5 – 22.5
		VAM250FA	50	155	250	23.3 – 37.5
			60	145	250	21.8 – 37.5
		VAM350FA	50	230	350	34.5 – 52.5
			60	210	350	31.5 – 52.5
		VAM500FA	50	350	500	52.5 – 75.0
			60	300	500	45.0 – 75.0
		VAM650FA	50	500	650	75.0 – 97.5
	60		440	650	66.0 – 97.5	
	VAM800FA	50	670	800	100.5 – 120.0	
		60	660	800	99.0 – 120.0	
	VAM1000FA	50	870	1000	130.5 – 150.0	
		60	800	1000	120.0 – 150.0	
	VAM1500FA	50	1200	1500	180.0 – 225.0	
		60	1200	1500	180.0 – 225.0	
	VAM2000FA	50	1400	2000	210.0 – 300.0	
		60	1400	2000	210.0 – 300.0	
	5	VAM150FA	50	110	150	27.5 – 37.5
			60	110	150	27.5 – 37.5
		VAM250FA	50	155	250	38.8 – 62.5
			60	145	250	36.3 – 62.5
		VAM350FA	50	230	350	57.5 – 87.5
			60	210	350	52.5 – 87.5
		VAM500FA	50	350	500	87.5 – 125.0
			60	300	500	75.0 – 125.0
		VAM650FA	50	500	650	125.0 – 162.5
60	440		650	110.0 – 162.5		
VAM800FA	50	670	800	167.5 – 200.0		
	60	660	800	165.0 – 200.0		
VAM1000FA	50	870	1000	217.5 – 250.0		
	60	800	1000	200.0 – 250.0		
VAM1500FA	50	1200	1500	300.0 – 375.0		
	60	1200	1500	300.0 – 375.0		
VAM2000FA	50	1400	2000	350.0 – 500.0		
	60	1400	2000	350.0 – 500.0		
10	VAM150FA	50	110	150	55.0 – 75.0	
		60	110	150	55.0 – 75.0	
	VAM250FA	50	155	250	78.0 – 125.0	
		60	145	250	72.0 – 125.0	
	VAM350FA	50	230	350	115.0 – 175.0	
		60	210	350	105.0 – 175.0	
	VAM500FA	50	350	500	175.0 – 250.0	
		60	300	500	150.0 – 250.0	
	VAM650FA	50	500	650	250.0 – 325.0	
60		440	650	220.0 – 325.0		
VAM800FA	50	670	800	335.0 – 400.0		
	60	660	800	330.0 – 400.0		
VAM1000FA	50	870	1000	435.0 – 500.0		
	60	800	1000	400.0 – 500.0		
VAM1500FA	50	1200	1500	600.0 – 750.0		
	60	1200	1500	600.0 – 750.0		
VAM2000FA	50	1400	2000	700.0 – 1000.0		
	60	1400	2000	700.0 – 1000.0		

6 Selection Procedures

6 - 2 Based on Room size

Required ventilating AFR per person (m ³ / h / person)	Area per person (m ² / person)	Model Name	Frequency	Air Flow Rate		Application area (m ²)
			Hz	L	H	
40	3	VAM150FA	50	110	150	8.3 – 11.3
			60	110	150	8.3 – 11.3
		VAM250FA	50	155	250	11.6 – 18.8
			60	145	250	10.9 – 18.8
		VAM350FA	50	230	350	17.3 – 26.3
			60	210	350	15.8 – 26.3
		VAM500FA	50	350	500	26.3 – 37.5
			60	300	500	22.5 – 37.5
		VAM650FA	50	500	650	37.5 – 48.8
			60	440	650	33.0 – 48.8
	VAM800FA	50	670	800	50.3 – 60.0	
		60	660	800	49.5 – 60.0	
	VAM1000FA	50	870	1000	65.3 – 75.0	
		60	800	1000	60.0 – 75.0	
	VAM1500FA	50	1200	1500	90.0 – 112.5	
		60	1200	1500	90.0 – 112.5	
	VAM2000FA	50	1400	2000	105.0 – 150.0	
		60	1400	2000	105.0 – 150.0	
	5	VAM150FA	50	110	150	13.8 – 18.8
			60	110	150	13.8 – 18.8
		VAM250FA	50	155	250	19.4 – 31.3
			60	145	250	18.1 – 31.3
		VAM350FA	50	230	350	28.8 – 43.8
			60	210	350	26.3 – 43.8
		VAM500FA	50	350	500	43.8 – 62.5
			60	300	500	37.5 – 62.5
		VAM650FA	50	500	650	62.5 – 81.3
			60	440	650	55.0 – 81.3
	VAM800FA	50	670	800	83.8 – 100.0	
		60	660	800	82.5 – 100.0	
VAM1000FA	50	870	1000	108.8 – 125.0		
	60	800	1000	100.0 – 125.0		
VAM1500FA	50	1200	1500	150.0 – 187.5		
	60	1200	1500	150.0 – 187.5		
VAM2000FA	50	1400	2000	175.0 – 250.0		
	60	1400	2000	175.0 – 250.0		
10	VAM150FA	50	110	150	27.5 – 37.5	
		60	110	150	27.5 – 37.5	
	VAM250FA	50	155	250	38.8 – 62.5	
		60	145	250	36.3 – 62.5	
	VAM350FA	50	230	350	57.5 – 87.5	
		60	210	350	52.5 – 87.5	
	VAM500FA	50	350	500	87.5 – 125.0	
		60	300	500	75.0 – 125.0	
	VAM650FA	50	500	650	125.0 – 162.5	
		60	440	650	110.0 – 162.5	
VAM800FA	50	670	800	167.5 – 200.0		
	60	660	800	165.0 – 200.0		
VAM1000FA	50	870	1000	217.5 – 250.0		
	60	800	1000	200.0 – 250.0		
VAM1500FA	50	1200	1500	300.0 – 375.0		
	60	1200	1500	300.0 – 375.0		
VAM2000FA	50	1400	2000	350.0 – 500.0		
	60	1400	2000	350.0 – 500.0		

Note:

1. AFR: Air Flow Rate

7 Product Specification

7-1 Technical Specifications				VAM150FA	VAM250FA	VAM350FA	VAM500FA	VAM650FA	VAM800FA	VAM1000A	VAM1500A	VAM200FA	
Power input - 50Hz	Heat exchange mode	Nom.	Ultra high	kW	0.116	0.141	0.194	0.212	0.380	0.451	0.469	0.864	0.953
			High	kW	0.100	0.112	0.175	0.189	0.325	0.400	0.432	0.758	0.767
			Low	kW	0.056	0.062	0.111	0.118	0.227	0.346	0.349	0.655	0.653
	Bypass mode	Nom.	Ultra high	kW	0.116	0.141	0.194	0.212	0.380	0.451	0.469	0.864	0.953
			High	kW	0.100	0.112	0.175	0.189	0.325	0.400	0.432	0.758	0.767
			Low	kW	0.056	0.062	0.111	0.118	0.227	0.346	0.349	0.655	0.653
Power input - 60Hz	Heat exchange mode	Nom.	Ultra high	kW	0.117	0.138	0.226	0.253	0.432	0.514	0.571	0.981	1.017
			High	kW	0.099	0.119	0.214	0.232	0.384	0.471	0.537	0.929	1.021
			Low	kW	0.056	0.062	0.120	0.125	0.251	0.408	0.419	0.754	0.779
	Bypass mode	Nom.	Ultra high	kW	0.117	0.138	0.226	0.253	0.432	0.514	0.571	0.981	1.017
			High	kW	0.099	0.119	0.214	0.232	0.384	0.471	0.537	0.929	1.021
			Low	kW	0.056	0.062	0.120	0.125	0.251	0.408	0.419	0.754	0.779
Temperature exchange efficiency - 50Hz	Ultra high		%	74	72	75	74			75			
	High		%	74	72	75	74			75			
	Low		%	79	77	80	77		76	76.5	78		
Temperature exchange efficiency - 60Hz	Ultra high		%	74	72	75	74			75			
	High		%	74	72	75	74			75			
	Low		%	80	77	81	78.5	78	76	78			
Enthalpy exchange efficiency - 50Hz	Cooling	Ultra high	%	58		61	58		60	61			
		High	%	58		61	58		60	61			
		Low	%	64	62	67	63		62	63	64	66	
	Heating	Ultra high	%	64		65	62	63	65	66			
		High	%	64		65	62	63	65	66			
		Low	%	69	68	70	67	66	67	68		70	
Enthalpy exchange efficiency - 60Hz	Cooling	Ultra high	%	58		61	58		60	61			
		High	%	58		61	58		60	61			
		Low	%	66	63	68	65		63	66	64	66	
	Heating	Ultra high	%	64		65	62	63	65	66			
		High	%	64		65	62	63	65	66			
		Low	%	71	69	71	68.5	68		71	68	70	
Operation mode				Heat exchange mode Bypass mode Fresh-up mode									
Heat exchange system				Air to air cross flow total heat (sensible + latent heat) exchange									
Heat exchange element				Specially processed non-flammable paper									
Casing				Galvanized steel plate									
Dimensions	Unit	Height	mm	285		301	364			726			
		Width	mm	776		828	1,004			1,514			
		Depth	mm	525		816	868		1,156	868	1,156		
Weight	Unit	kg	24		33	48		61	132	158			

7 Product Specification

7-1 Technical Specifications				VAM150FA	VAM250FA	VAM350FA	VAM500FA	VAM650FA	VAM800FA	VAM1000A	VAM1500A	VAM200FA	
Fan	Type			Sirocco fan									
	Air flow rate - 50Hz	Heat exchange mode	Ultra high	m³/h	150	250	350	500	650	800	1,000	1,500	2,000
			High	m³/h	150	250	350	500	650	800	1,000	1,500	2,000
			Low	m³/h	110	155	230	350	500	670	870	1,200	1,400
		Bypass mode	Ultra high	m³/h	150	250	350	500	650	800	1,000	1,500	2,000
			High	m³/h	150	250	350	500	650	800	1,000	1,500	2,000
			Low	m³/h	110	155	230	350	500	670	870	1,200	1,400
	Air flow rate - 60Hz	Heat exchange mode	Ultra high	m³/h	150	250	350	500	650	800	1,000	1,500	2,000
			High	m³/h	150	250	350	500	650	800	1,000	1,500	2,000
			Low	m³/h	110	145	210	300	440	660	800	1,200	1,400
		Bypass mode	Ultra high	m³/h	150	250	350	500	650	800	1,000	1,500	2,000
			High	m³/h	150	250	350	500	650	800	1,000	1,500	2,000
			Low	m³/h	110	145	210	300	440	660	800	1,200	1,400
	External static pressure - 50Hz	Ultra high	Pa	69	64	98		93	137	157	137		
		High	Pa	39		70	54	39	98			78	
		Low	Pa	20		25			49	78	49	59	
External static pressure - 60Hz	Ultra high	Pa	98		142	147	162	225	196	206	196		
	High	Pa	54		85	54	69	118	108	118	88		
	Low	Pa	24	20	15	20	34	69					
Fan motor	Quantity			2								4	
	Output	50 Hz	W	30		90		140	230				
60 Hz		W	30		90		140	230					
Sound pressure level - 50Hz	Heat exchange mode	Ultra high	dBA	27 - 28.5	28 - 29	32 - 34	33 - 34.5	34.5 - 35.5	36 - 37	36 - 37	39.5 - 41.5	40 - 42.5	
		High	dBA	26 - 27.5	26 - 27	31.5 - 33	31.5 - 33	33 - 34	34.5 - 36	35 - 36	38 - 39	38 - 41	
		Low	dBA	20.5 - 21.5	21 - 22	23.5 - 26	24.5 - 26.5	27 - 28	31 - 32	31 - 32	34 - 36	35 - 37	
	Bypass mode	Ultra high	dBA	27 - 28.5	28 - 29	32 - 34	33.5 - 34.5	34.5 - 35.5	36 - 37	36 - 37	40.5 - 41.5	40 - 42.5	
		High	dBA	26.5 - 27.5	27 - 28	31 - 32.5	32.5 - 33.5	34 - 35	34.5 - 36	35.5 - 36	38 - 39	38 - 41	
		Low	dBA	20.5 - 21.5	21 - 22	24.5 - 26.5	25.5 - 27.5	27 - 28.5	31 - 33	31 - 32	33.5 - 36	35 - 37	
Sound pressure level - 60Hz	Heat exchange mode	Ultra high	dBA	28.5	29.5	34.5	34	36	37	40.5	41		
		High	dBA	26.5	26	32	31	33	35	38			
		Low	dBA	19	19.5	22	24	27	30	33	35		
	Bypass mode	Ultra high	dBA	28	29	34.5	35	35.5	37	40.5	41		
		High	dBA	27		33		34	35	38			
		Low	dBA	20	20.5	22	24	27	31	33	35		
Operation range	Min.	°CDB	-15										
	Max.	°CDB	50										
	Relative humidity	%	80% or less										
Connection duct diameter	mm	100	150	200		250	350						
Insulation material	Self-extinguishable urethane foam												
Air filter	Multidirectional fibrous fleeces												
Standard Accessories	Installation and operation manual												

7 Product Specification

7-2 Electrical Specifications				VAM150FA	VAM250FA	VAM350FA	VAM500FA	VAM650FA	VAM800FA	VAM1000FA	VAM1500FA	VAM2000FA			
Power supply	Name			VE											
	Phase			1~											
	Frequency	Hz		50/60											
	Voltage	V		220-240/220											
Voltage range	Min.	%		-10											
	Max.	%		10											
Current	Minimum circuit amps (MCA)			A	0.9		1.35		2.3		3.4		6.75		
	Maximum fuse amps (MFA)			A	15										
	Fan motor rated output			kW	0.03x2		0.09x2		0.14x2		0.23x2		0.23x4		
	Full load amps (FLA)	Fan motor		A	0.4		0.6		1.0		1.5				
		Fan motor 2		A	0.4		0.6		1.0		1.5				
		Fan motor 3		A	-									1.5	
		Fan motor 4		A	-									1.5	
	Normal amps - 50Hz	Heat exchange mode	Ultra high	A	0.67	0.72	1.00	1.02	1.81	2.53	2.46	4.97	5.00		
			High	A	0.57		0.85	0.87	1.55	2.15	2.16	4.12	3.97		
			Low	A	0.33	0.32	0.54	0.55	1.08	1.79	1.74	3.43	3.27		
		Bypass mode	Ultra high	A	0.67	0.72	1.00	1.02	1.81	2.53	2.46	4.97	5.00		
			High	A	0.57		0.85	0.87	1.55	2.15	2.16	4.12	3.97		
			Low	A	0.33	0.32	0.54	0.55	1.08	1.79	1.74	3.43	3.27		
	Normal amps - 60Hz	Heat exchange mode	Ultra high	A	0.66	0.64	1.01	1.16	1.98	2.46	2.66	4.72	4.73		
High			A	0.59	0.56	1.00	1.05	1.75	2.29	2.53	4.49	4.77			
Low			A	0.33	0.29	0.58	0.59	1.16	2.02	2.03	3.71	3.30			
Bypass mode		Ultra high	A	0.66	0.64	1.01	1.16	1.98	2.46	2.66	4.72	4.73			
		High	A	0.59	0.56	1.00	1.05	1.75	2.29	2.53	4.49	4.77			
		Low	A	0.33	0.29	0.58	0.59	1.16	2.02	2.03	3.71	3.73			

Notes:

- (1) Operation sound is measured at 1.5m below the center of the body.
- (2) Air flow rate can be changed to Low mode or High mode.
- (3) Normal amplitude, input and efficiency depend on the mentioned conditions.
- (4) Sound values are measured in an anechoic chamber. Operating sound level generally becomes higher than this value depending on the operating conditions, reflected sound and peripheral noise.
- (5) The noise level at the air discharge port is about 8dB higher than the operating sound of the unit.
- (6) The specifications, designs and information here are subject to change without notice.
- (7) Voltage range: units are suitable for use on electrical systems where voltage supplied to unit terminal is not below or above listed range limits.
- (8) Maximum allowable voltage range variation between phases is 2%.
- (9) MCA/MFA: MCA = 1.25 x FLA(FM1) + FLA(FM2); MFA ≤ 4 x FLA; (VAM2000 is regarded as 2x VAM1000)
- (10) Select wire size based on the value of MCA.
- (11) Instead of a fuse, use a circuit breaker.

7 Product Specification

7 - 2 Optional accessories Installation example

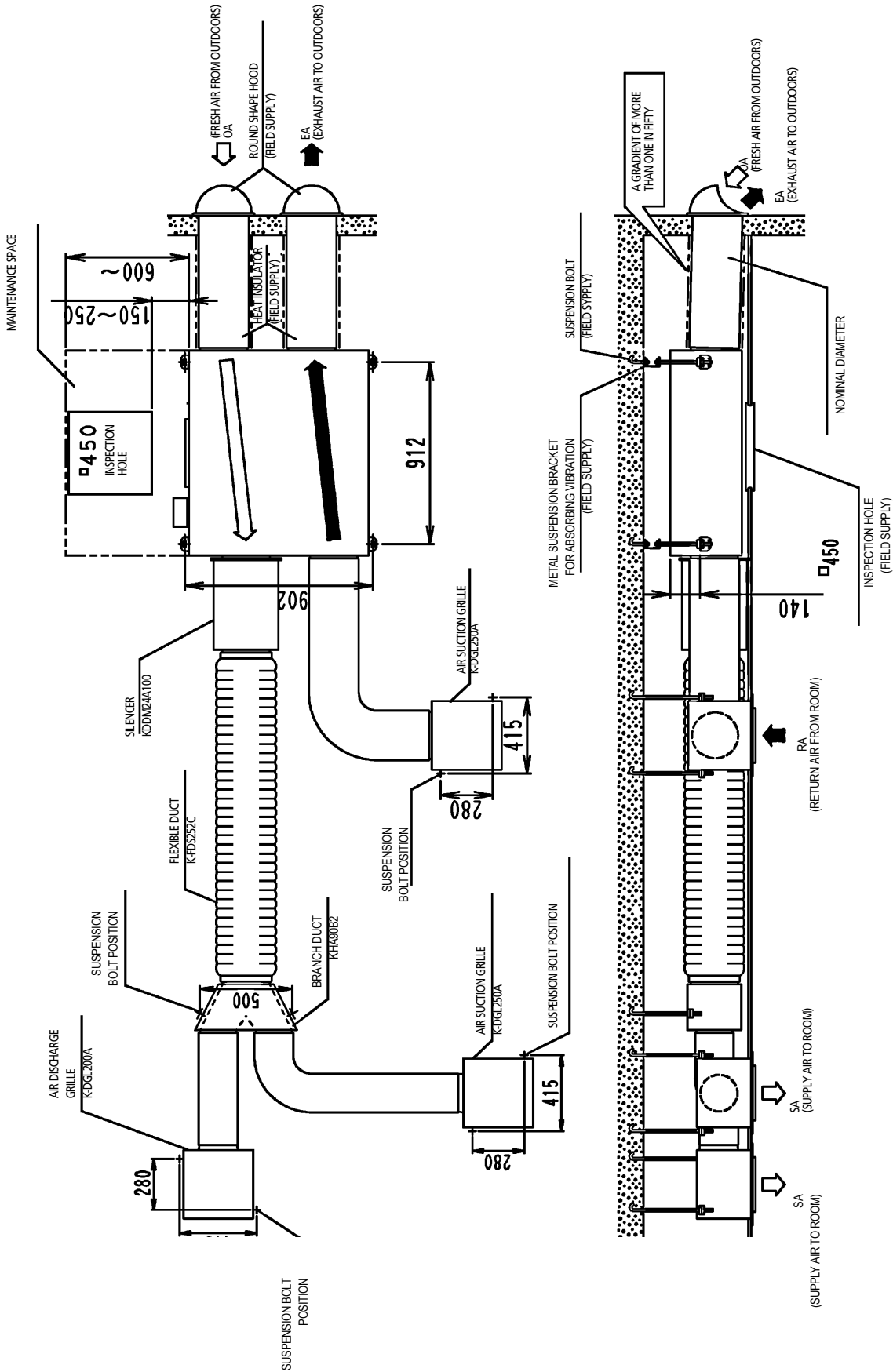

7 Product Specification

7 - 2 Optional accessories

VAM-FA

Item		Model									
		VAM150FA	VAM250FA	VAM350FA	VAM500FA	VAM650FA	VAM800FA	VAM1000FA	VAM1500FA	VAM2000FA	
Controlling device	Remote control								BRC301B61		
	Wired remote control								BRC1C52		
									BRC1E51A (note 4)		
	Centralized controlling device	Central remote control								DCS302C51	
		Unified on/off control								DCS301B51	
		Schedule timer								DST301B51	
	PC board adapter	Wiring adapter for electrical appendices								KRP2A51	
		For humidifier								KRP50-2	
Installation box for adapter PCB									KRP50-2A90 (Mounted electric component assy of HRV)		
For heater control kit									BRP4A50		

Interlock adapter for VRV®

Indoor unit	FXFQ	FXZQ	FXCQ	FXKQ	FXDQ-M9	FXDQ-P7	FXSQ	FXMQ-P	FXMQ-MA	FXAQ	FXUQ	FXHQ	FXLQ	FXNQ
Adapter for wiring	-	KRP1B57 *	-	KRP1B61	KRP1B61	KRP1B56	-	KRP1C64 (note 4)	KRP1B61	-	KRP4A53	KRP1B3	KRP1B61	KRP1B61
	EKRP1C11 *	-	EKRP1B2	-	EKRP1B2 (note 6)	-	KRP1B2A (note 5)	-	-	-	-	-	-	-
Installation box for adapter PCB	KRP1H98	KRP1BA101	KRP1B96 (note 2/3)	-	-	KRP1BA101	EKRP4A96 (note 2/3)	-	KRP4A93 (note 2/3)	KRP1B97	KRP1C93 (note 2)	-	-	-

Item		Model									
		VAM150FA	VAM250FA	VAM350FA	VAM500FA	VAM650FA	VAM800FA	VAM1000FA	VAM1500FA	VAM2000FA	
Additional function	Silencer	Model name	-	-	-	KDDM24A50	KDDM24A100	KDDM24A100	KDDM24A100	KDDM24A100 x 2	KDDM24A100 x 2
		Nominal pipe diameter (mm)	-	-	-	ø 200	ø 200	ø 250	ø 250	ø 250	ø 250
Duct adapter	Air filter for replacement	Model name	YAFF323F15	YAFF323F25	YAFF323F35	YAFF323F50	YAFF323F65	YAFF323F65	YAFF323F100	YAFF323F65 x 2	YAFF323F100 x 2
		Nominal pipe diameter (mm)	-	-	-	-	-	-	-	YDFA25A1	YDFA25A1
Direct expansion coil unit		Model name	-	-	-	VKM50G	VKM80G	VKM80G	VKM100G	-	-
Adapter for discharge		Model name	-	-	-	KDAJ25K36	KDAJ25K56	KDAJ25K56	KDAJ25K56	-	-

NOTES

1. Installation box marked with ** is required for each adapter marked with *.
2. Up to 2 adapters can be fixed for each installation.
3. Only one installation box can be installed for each indoor unit.
4. Included languages are: English, German, French, Dutch, Spanish, Italian, Greek, Portuguese, Russian and Turkish.
5. Mounting plate KRP4A96 is required. Maximum 2 option PCBs can be mounted.
6. Fixing box is KRP1A90

3TW24921-1B

7 Product Specification

7 - 2 Optional accessories

7-2-1 BRC301B61: Remote control

7-2-1-1 Remote control mounting instructions

1. Remove the upper part of remote control.

Insert minus screwdriver into the slots in the lower part of remote controller (2 places), and remove the upper part of remote control.

The PC board is mounted in the upper part of remote control. Be careful not to damage the board with the minus screwdriver.

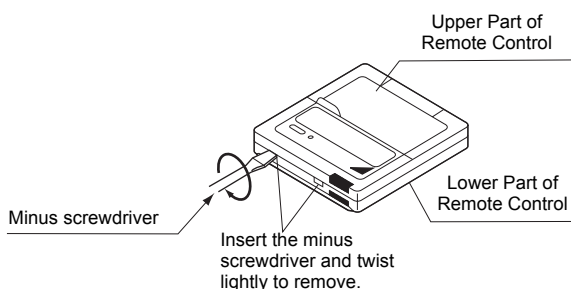

2. Fasten the remote control.

- ① For exposed mounting, fasten with the included wood screws (2).
- ② For flush-mounting, fasten with the included machine screws (2).

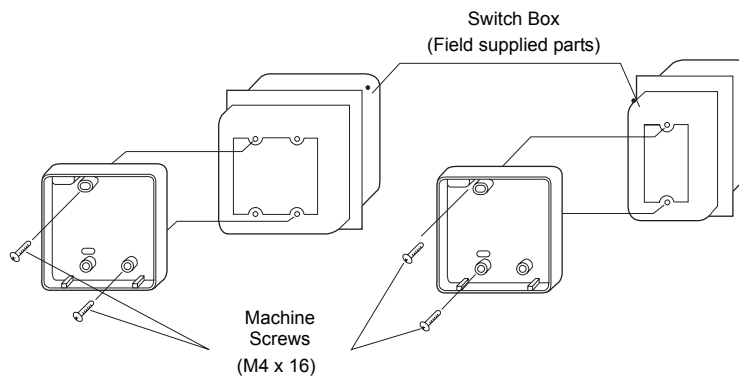
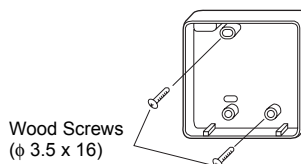

For the field supplied switch box, use optional accessories KJB111A or KJB211A.

NOTE

Choose the flattest place possible for the mounting surface. Be careful not to damage the shape of the lower part of remote control by over-tightening the mounting screws.

(HC0111)
2P034150

7 Product Specification

7 - 2 Optional accessories

7-2-1 BRC301B61: Remote control

7-2-1-1 Remote control mounting instructions

3. Wire the HRV unit.

Connect the terminals on the upper part of the remote control (P1, P2) and the terminals of the HRV unit (P1, P2).

(P1 and P2 do not have polarity.)

NOTE

When wiring, run the wiring away the power supply wiring in order to avoid receiving electric noise (external noise).

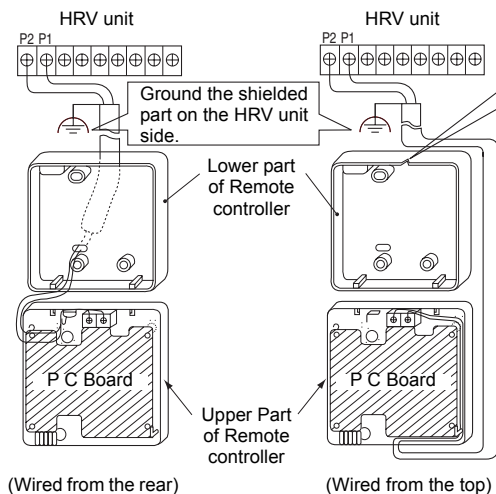

Notch the part for the wiring to pass through with nippers, etc.

Wiring Specifications

Wiring Type	Shield Wire (2 wire) (See NOTE 3)
Size	0.75 – 1.25 mm ²

NOTE:

1. Peel the shield and sheath for the part that is to pass through the inside of the remote control case, as shown in the figure below.

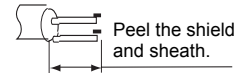

2. Treat the terminal for the wire to be connected to the remote control so the shielded part doesn't touch any other part.
3. Sheathed wire may be used for transmission wirings, but they do not comply with EMC (Electromagnetic Compatibility) (European Directive). When using sheathed wire, EMC must conform to Japanese standards stipulated in the Electric Appliance Regulatory Act. (If using a sheathed wire, the grounding shown in the figure on the left is unnecessary.)

Reattach the upper part of remote control.

Be careful not to pinch the wiring when attaching.

NOTE

1. The switch box and wiring for connection are not included.
2. Do not directly touch the PC board with your hand.

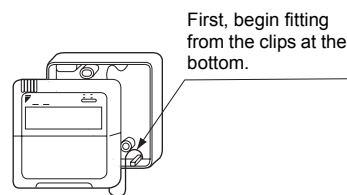

When controlling one HRV unit with two remote controls

Change the MAIN/SUB changeover switch setting as described below.

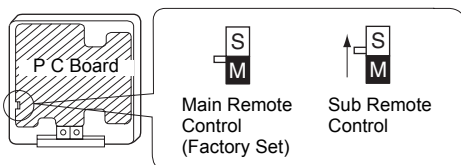

Set one remote control to "main," and the other to "sub."

NOTE

- If controlling with one remote control, be sure to set it to "main."
- Set the remote control before turning power supply on.

"88" is displayed for about one minute when the power supply is turned on, and the remote control cannot be operated in some cases.

7 Product Specification

7 - 2 Optional accessories

- 7-2-2 KRP50-2: Wiring adapter for remote contact / Humidifier
- KRP50-2A90: Installation box for adapter PCB

Components

1. KRP50-2 PCB (x1)	2. PCB catches (4 large, 4 small)
Tie wrap(x1)	Manual(x1)

Installation guide

1 The KRP50-2 can be connected to HRV units as follows to send the operation signal (pilot lamp etc.) to remote locations.

Electric wiring is as follows.

- For Remote contact

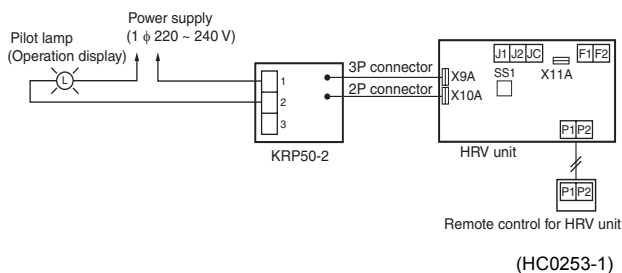

2 KRP50-2 can also be connected to SkyAir indoor unit for the interlocked operation with HRV units.

Components

See the right for components.

Fixing Screw	3 PCS.
Clamp	2 PCS.

Installation

Install the Adapter PCB to the outside of switch box for HRV unit as show below.

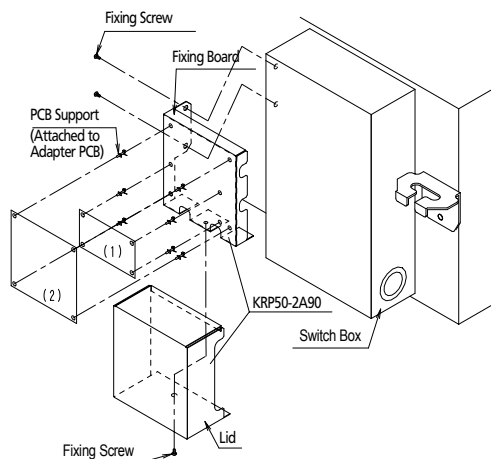

Applicable adapter

	Adapter name	Kit name
(1)	Adapter PCB for Humidifier	KRP50-2
(2)	Adapter PCB for Remote control	KRP2A61

4P055444

- For Humidifier

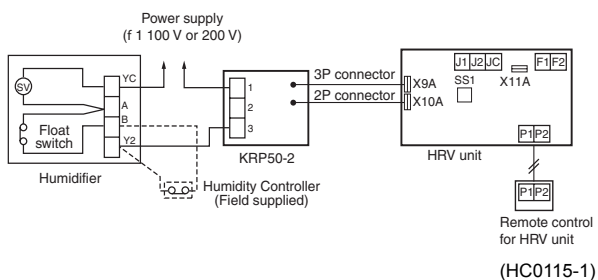

7 Product Specification

7 - 2 Optional accessories

7-2-3 KRP2A51, KRP2A61: Wiring adapter for electrical appendices

KRP2A51 (For Europe)
KRP2A61 (For General)

Accessories

Check the following accessories are included in the kit before the installation.

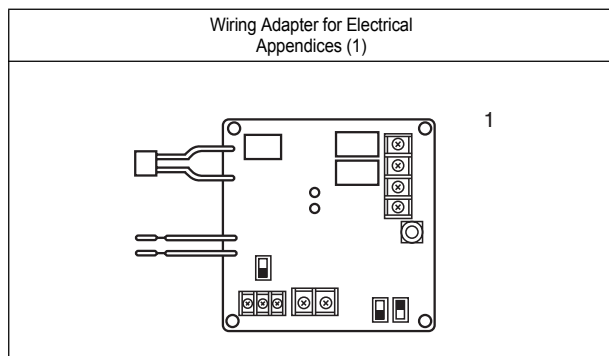

PCB support	× 4
Clamp	× 3
Installation Manual	× 1

Notes:

- The kit type (KRP2A61 • 51 type, KRP2A62 • 52 type) varies according to air conditioner model.
- The installation plate and box for adapter PCB are required with the following air conditioner models.
 FXYFP KRP1A90 or KRP1B94
 FXYFP KRP1C98
 FXH KRP1B93
 FXYCP KRP1B96

General description of system

The KRP2A61 • 62 • 51 • 52 enables operation by remote control (ON/OFF control, temperature setting, operation display, error display). With it, the following system can be built. Note however that the adapter cannot be used with other optional controllers for centralized control.

1. Zone control
 (Unified control of a max. 64 groups of a max. 16 indoor units each.
 But the max. of indoor units is 128)

This system requires the following parts.	
• Wiring Adapter for Electrical Appendices (1)	
...KRP2A61(62) or KRP2A51(52)	
• Remote control switches (For control)	
...BRC1C517	} Per group
BRC2A51	
BRC3A61	
(Ex.) Zone control for 8 FXYC63KVE units (control groups of 4, 3 and 1)	
KRP2A51 × 1 kit	} (1 set required for each group.)
BRC1C517 × 3 kits	

(HC0116)

7 Product Specification

7 - 2 Optional accessories

7-2-3 KRP2A51, KRP2A61: Wiring adapter for electrical appendices

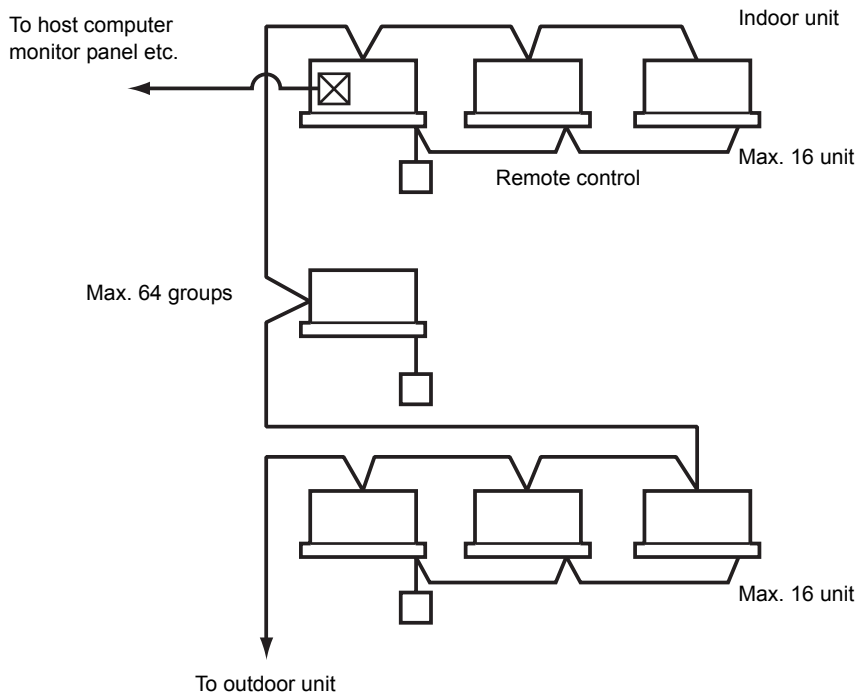

Notes:

Individual indoor units connected to the centralized line cannot be displayed individually.

Names of parts and functions

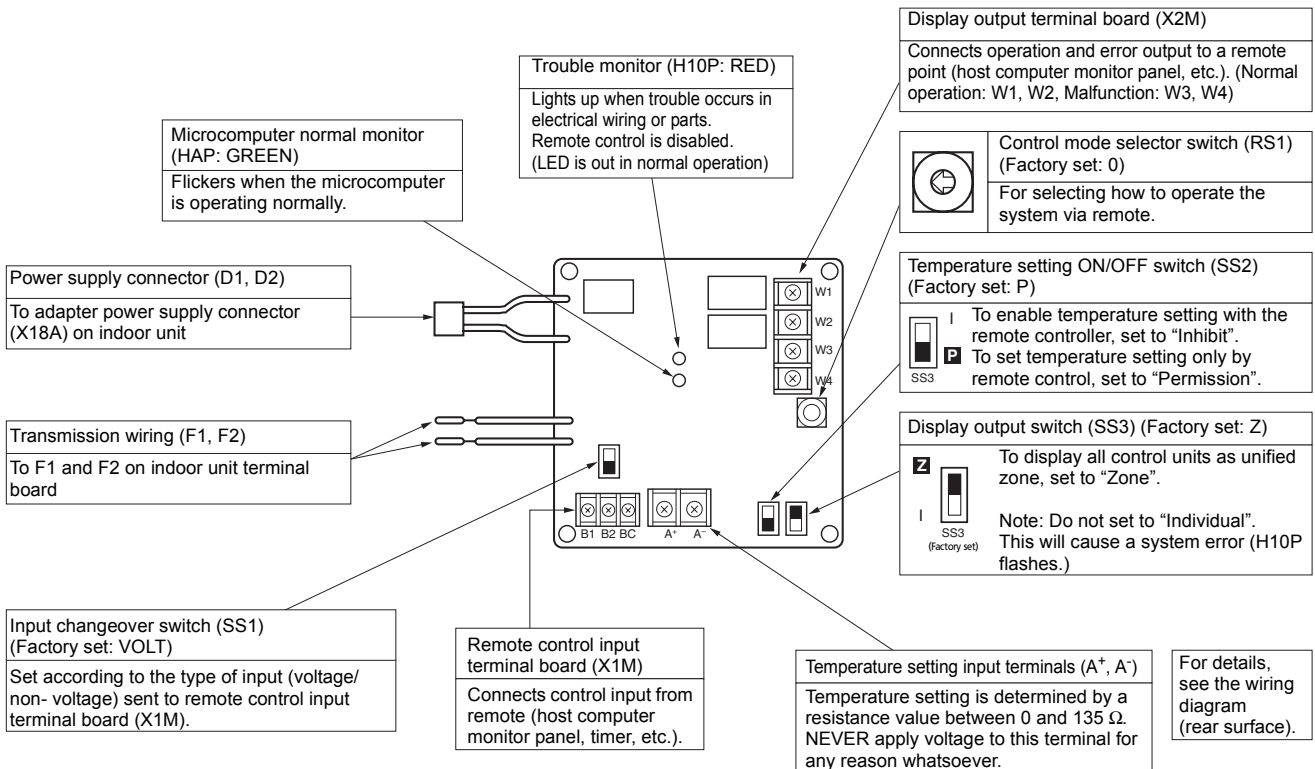

(HC0117)

7 Product Specification

7 - 2 Optional accessories

7-2-3 KRP2A51, KRP2A61: Wiring adapter for electrical appendices

Installation

Ceiling mounted corner cassette

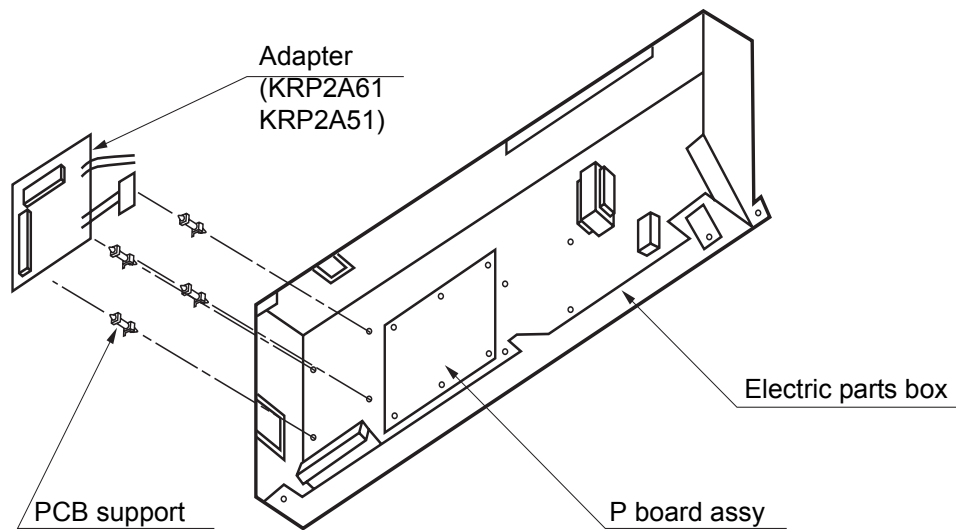

(HC0118)

4-way blow ceiling mounted cassette

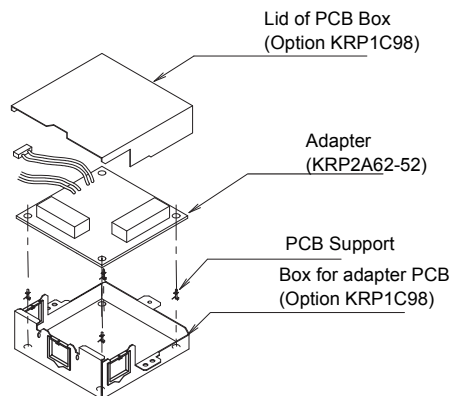

Note:

To install the adapter.
Box for adapter PCB (option) is required.

(HC0119)

7 Product Specification

7 - 2 Optional accessories

7-2-3 KRP2A51, KRP2A61: Wiring adapter for electrical appendices

2-way blow ceiling mounted cassette

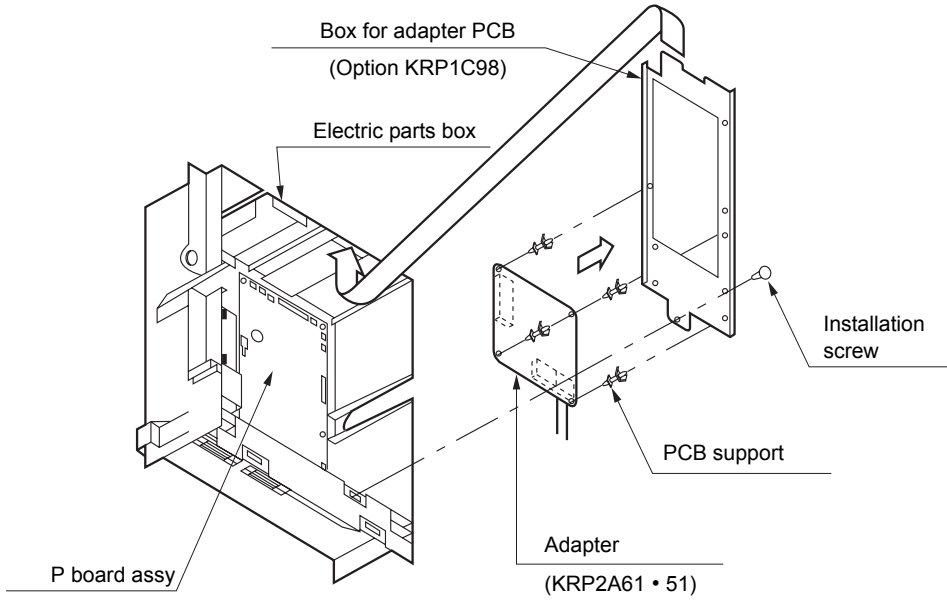

Note:

A separate plate is needed to install the adapter PCB.

(HC0247)

Wall mounted unit

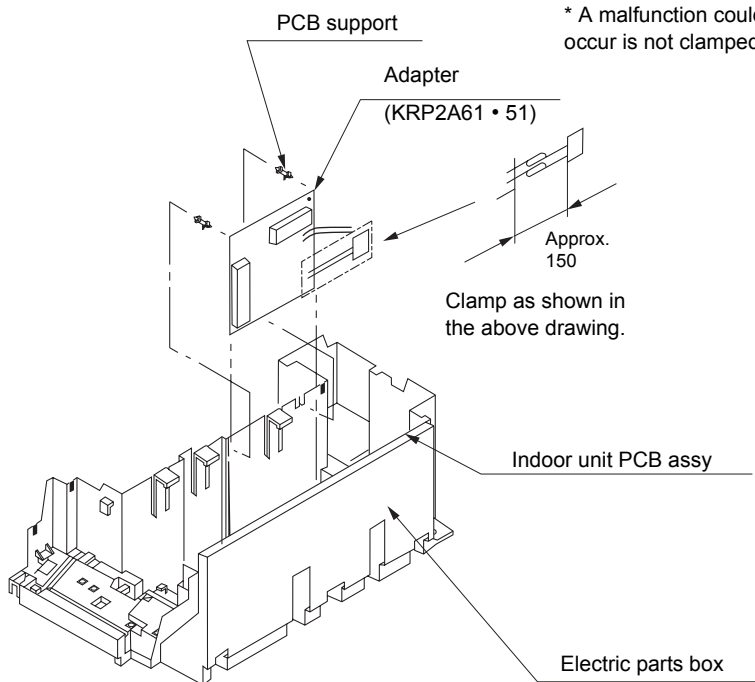

(HC0120)

7 Product Specification

7 - 2 Optional accessories

7-2-3 KRP2A51, KRP2A61: Wiring adapter for electrical appendices

Concealed ceiling unit (large)

40-125

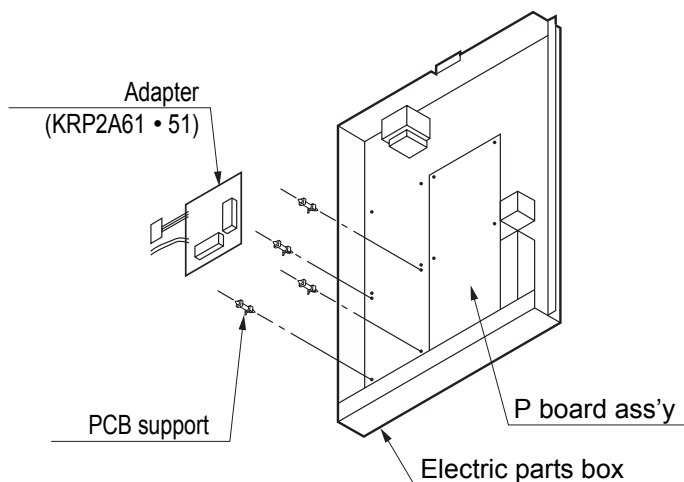

(HC0248)

200 • 250

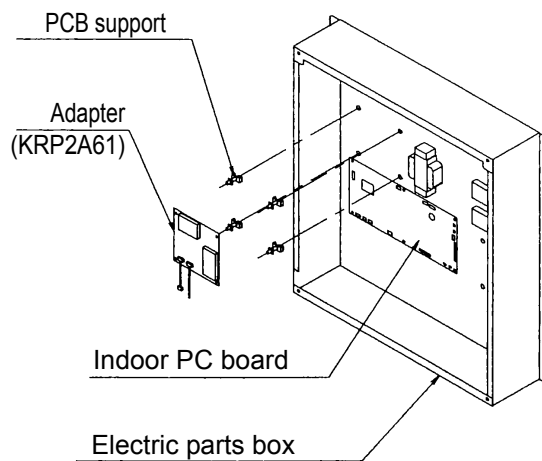

(V0219)

Ceiling suspended unit

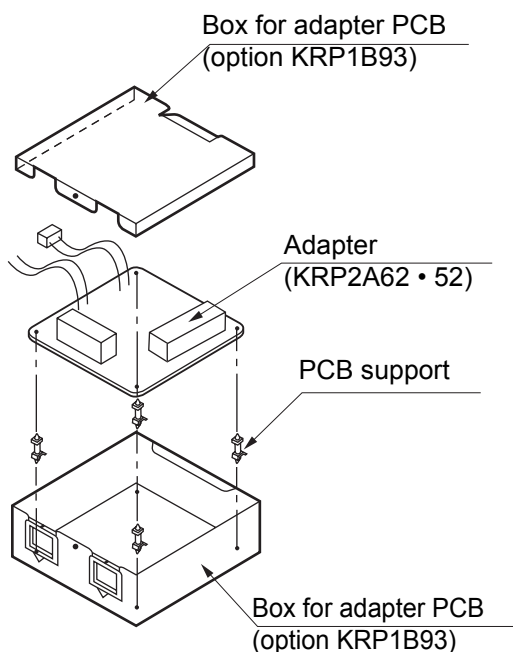

(HC0249)

Concealed ceiling unit

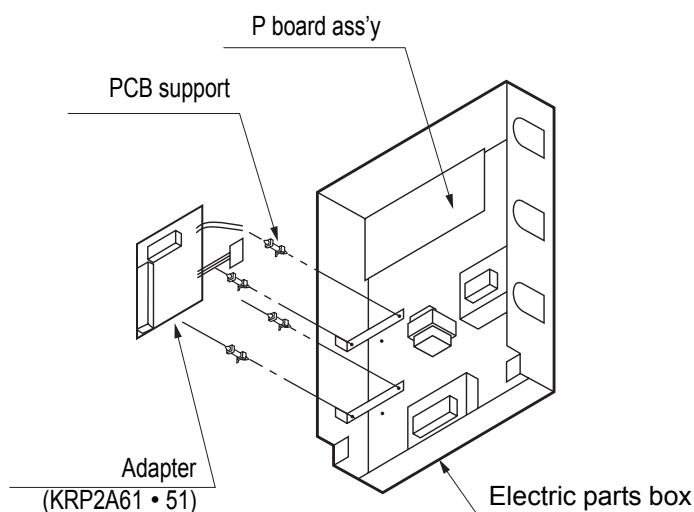

(HC0121)

Note:

A separate plate is needed to install the adapter PCB.

7 Product Specification

7 - 2 Optional accessories

7-2-3 KRP2A51, KRP2A61: Wiring adapter for electrical appendices

(Concealed) floor standing unit

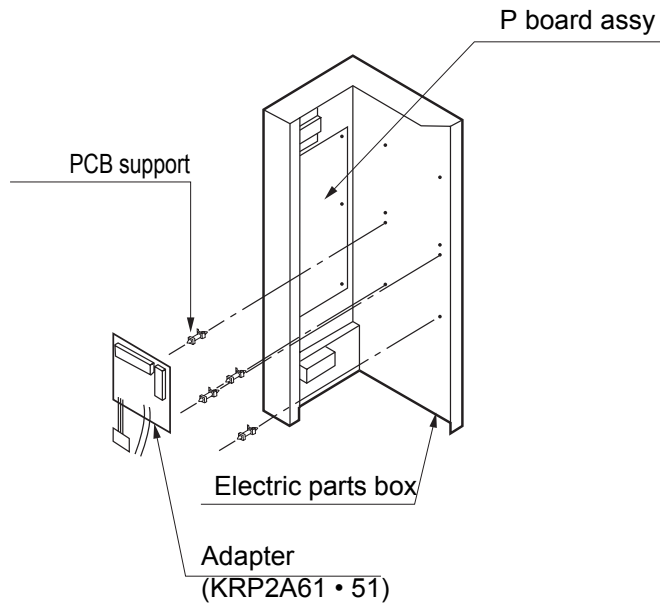

(HC0250)

Electrical wiring

1. First, wire between the indoor and outdoor units, then to the separate power sources, and between the indoor units and the remote controls. Then, check wiring is correct. (If wanting group control by remote control, check transmission wiring.) For details, see the installation manual of the indoor and outdoor units.
2. Next, wire between the wiring adapter for electrical appendices (1) and the indoor units. For details, see Wiring to indoor units.
3. Finally, wire between external units such as the host computer monitor panel, and make the necessary settings. For details, see Wiring to external units (host computer monitor panel).

Note:

It is not necessary to set address No. for centralized control. (Setting is automatic)

(HC0122)

7 Product Specification

7 - 2 Optional accessories

7-2-3 KRP2A51, KRP2A61: Wiring adapter for electrical appendices

Wiring to indoor units

1. For zone control

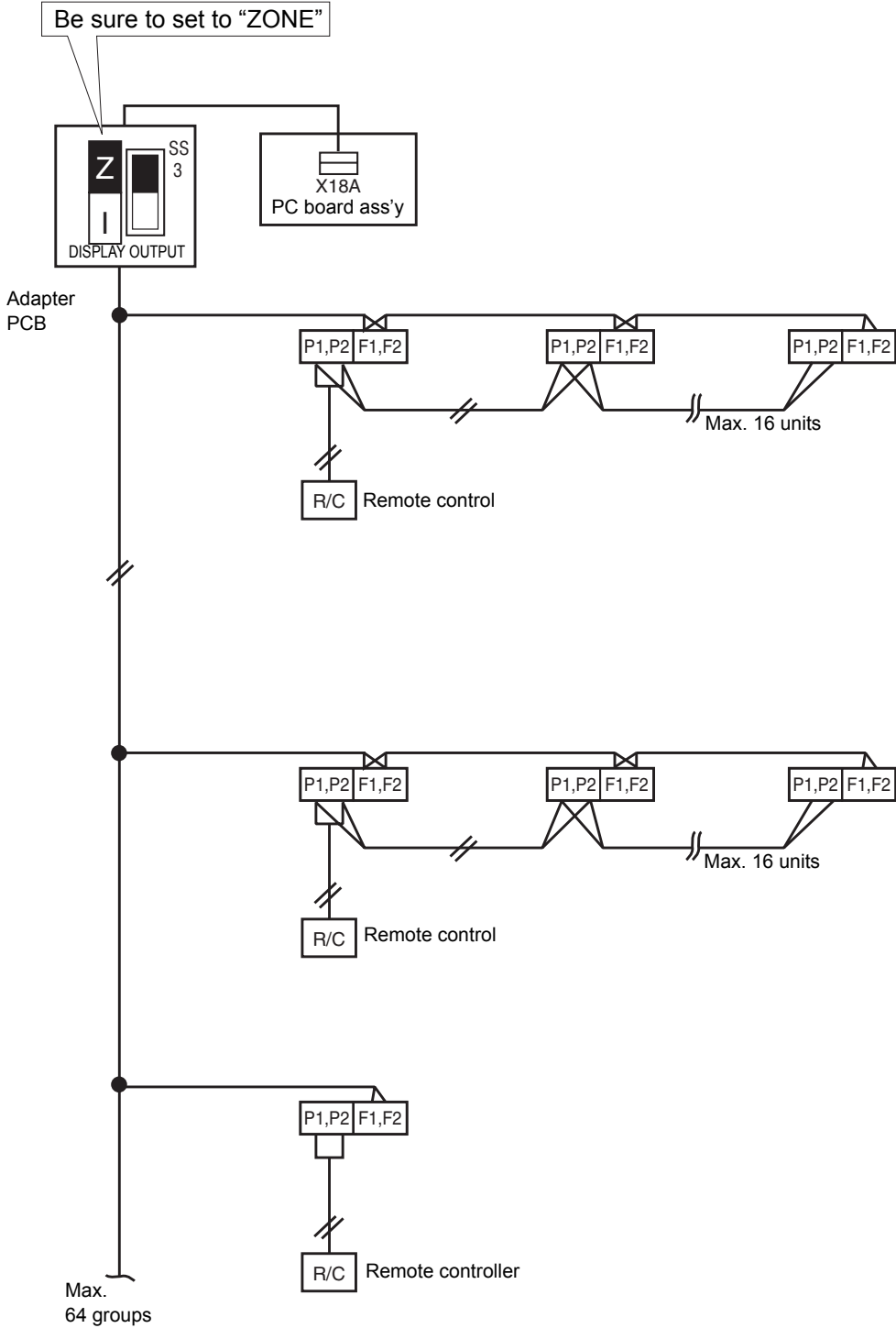

(Wiring specifications)
 Wiring Sheathed wire (2-wire)
 Gauge 0.75 ~ 1.25 mm²
 Length Max. 1000 m

< IMPORTANT >
 Keep transmission wiring at least 50 mm away from power supply wiring to avoid malfunctions.

(HC0123)

7 Product Specification

7 - 2 Optional accessories

7-2-3 KRP2A51, KRP2A61: Wiring adapter for electrical appendices

Wiring to external units (host computer monitor panel)

1. Remote control input (operation control)

Wire as described below. Wiring differs depending on whether using a voltage or non-voltage input.

- For voltage input

Set input changeover switch (SS1) to "VOLT".
(Factory set: VOLT)

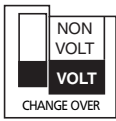

Connect the control input to the common contact (non-polarity).

Use a 12-24 V external power supply. Each contact requires approximately 10 mA, therefore carefully select power supply capacity.

Use a micro-current contact of a minimum current load of 12 V, 1 mA or less.

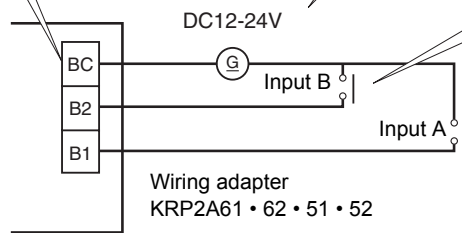

- For non-voltage input

Set input changeover switch (SS1) to "NON VOLT".

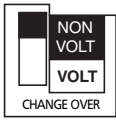

Use a micro-current contact of a minimum current load of 12 V, 1 mA or less.

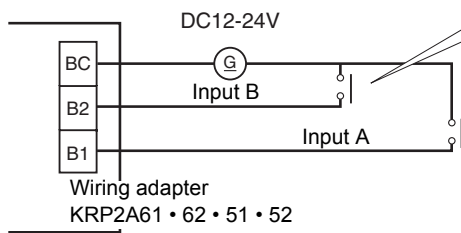

(Wiring specifications)
 Wiring Sheathed wire
 Gauge 0.18 ~ 1.25 mm²
 Length Max. 150 m

< IMPORTANT >
 Keep transmission wiring at least 50 mm away from power supply wiring to avoid malfunctions.

(HC0124)

7 Product Specification

7 - 2 Optional accessories

7-2-3 KRP2A51, KRP2A61: Wiring adapter for electrical appendices

2. Setting control mode selector switch (RS1)

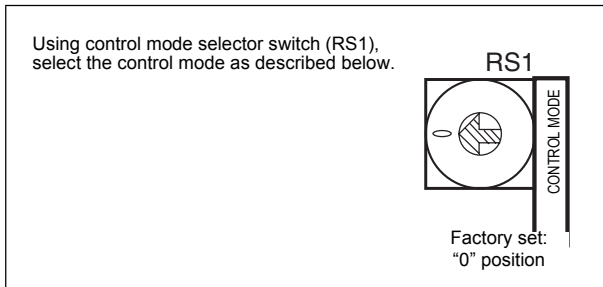

1. When operating with only individual display function

Position	Function
0	Individual display (input ignored)

2. When operating with constant input from A

Position	Function	Contents when input A is ON	Contents when input A is OFF
1	Remote control rejection	Operation (remote control is normally rejected)	
2	Central priority	Operation + remote control accepted	
3	Stop by remote control acceptable	Operation + stop by remote control acceptable (No operation by the remote control)	Stop + remote control rejection
4	Remote control acceptance/rejection	Remote control acceptance only (No operation by the remote location)	

Note:

- Input B is for forced-OFF. When ON, stop + remote controller is rejected, and input A is ignored. When OFF, even if A is ON, the contents of when input A is ON are not achieved. Input A must therefore be re-input.

3. When operating with momentary input from A (Use a momentary input of ON time 200 milli-sec or longer.)

Position	Function	Contents of Input A	Function of Input B
5	Remote control rejected	Stop for ON while operating, Operate for ON while stopping	
6	Last command priority	Stop for ON while operating, Operate for ON while stopping (Remote control is normally accepted.)	Input B will be forced stop function (When ON, stop + remote control is rejected, input A is ignored.)

- For demand control from input B

(HC0125)

7 Product Specification

7 - 2 Optional accessories

7-2-3 KRP2A51, KRP2A61: Wiring adapter for electrical appendices

- For demand control from input B

Position	Function when input A is ON	Function when input B is ON
C	Remote control rejected (Same as position "5")	Forced thermostat OFF command
D		Forced temperature shift command
E	Last command priority (Same as position "6")	Forced thermostat OFF command
F		Forced temperature shift command

- Forced thermostat OFF command
Forces indoor unit to operate the fan only
- Forced temperature shift command
The indoor unit operates at 2°C higher (cooling) or 2°C lower (heating) than the set temperature.

Notes:

- In zone control, operation is displayed as long as one indoor unit is running.
When in the last command priority mode, some units are not operation while ON.
 - In such case, even if input A is ON, the unit and all other units in the same zone will stop.
4. When operating with dual momentary inputs from A and B
(Use a momentary input of 200 mili-sec or longer.)

Position	Function	Contents when input A is ON	Contents when input A is OFF
7	Remote control rejection	Operation (remote control is normally rejected)	
8	Central priority	Operation + remote controller accepted	
9	Stop by remote control acceptable	Operation + stop by remote control acceptable (No operation by the remote controller)	Stop + remote control rejection
A	Remote control acceptance/rejection	Remote control acceptance only (No operation by the remote location)	
B	Last command priority	Operation (remote control is normally accepted)	Stop (remote control normally accepted)

Note:

- Doing constant input A with position 7 to A, it will be forced OFF function (input A is ignored.)
- Constant input cannot use for input B with position B.

(HC0126)

7 Product Specification

7 - 2 Optional accessories

7-2-3 KRP2A51, KRP2A61: Wiring adapter for electrical appendices

3. Temperature setting input

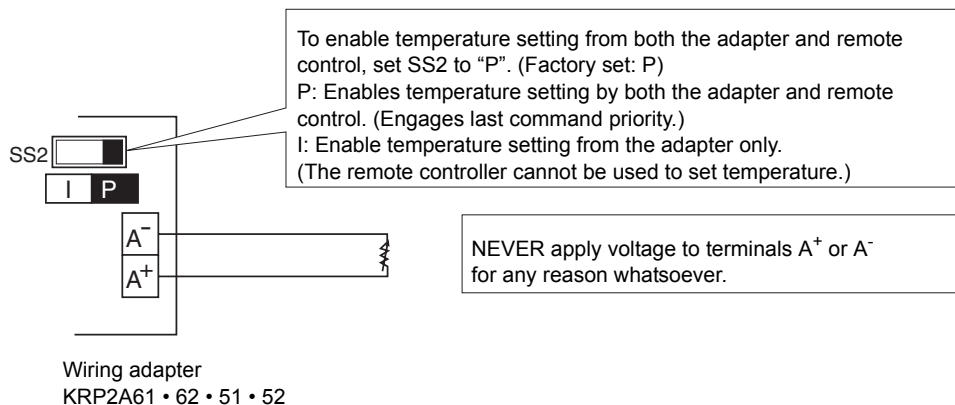

Temperature setting corresponds to resistance values in the range of 0 to 135 Ω. Their relationship is as shown below

Temperature setting (°C)	16	17	18	19	20	21	22	23	24
Resistance (Ω)	0.0 3.4	5.0 11.6	13.8 20.0	22.4 28.4	31.0 36.4	39.4 44.8	48.2 52.8	56.6 61.2	65.2 69.4
Temperature setting (°C)	25	26	27	28	29	30	31	32	
Resistance (Ω)	73.8 77.8	82.4 85.8	91.0 94.0	99.4 102.2	108.6 110.4	117.2 119.2	125.8 127.4	134.2 140.0	

Note:

Wiring resistance included in above figures.

(Wiring specifications)
 Wiring Sheathed wire
 Gauge 1.25 ~ 2.00 mm²
 Length Max. 70m

< IMPORTANT >
 Keep transmission wiring at least 50 mm away from power supply wiring to avoid malfunctions.

7 Product Specification

7 - 2 Optional accessories

7-2-3 KRP2A51, KRP2A61: Wiring adapter for electrical appendices

4. Cancelling display signals

Operation output terminals (W1 and W2) and malfunction output terminals (W3 and W4) are non-voltage constant contact output. (Allowed electric current per contact is between 10 mA and 3A.)

Normal operation output (Ry1)
ON when the unit is operating normally.

Malfunction output (Ry2)
ON when the unit stops because of malfunction or when a malfunction of transmission occurs between the adapter and the indoor unit.

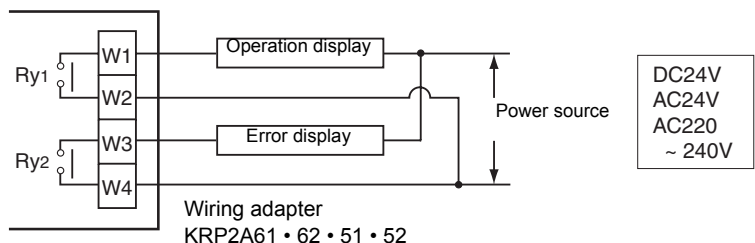

Note:

If using a 220 ~ 240 V power supply, keep transmission wiring at least 50 mm away from incoming power supply wiring.

(HC0127)

Output System	Both Ry1 and Ry2 OFF	Ry1 only ON	Ry2 only ON
Zone control	All zones OFF	At least one unit running normally, no malfunction	Even 1 unit stopped due to malfunction or malfunction of transmission between adapter and indoor unit

Display output is described by system in the below table.

Note:

If rewiring F1 and F2 after running the system, turn ON power for 5 minutes, then turn it OFF and ON again. Changes to wiring can sometimes disable control from the wiring adapter.

(HC0128)
1PA63642B

7 Product Specification

7 - 2 Optional accessories

7-2-4 KRP1B61: Interlock adapter of VRV

Accessories Check if the following accessories are included in the kit.

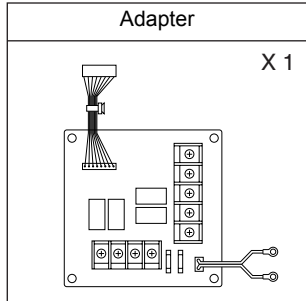

(HC0129)

PC board support	× 4
Clamp	× 3
Installation manual	× 1

- Notes**
- Kits vary according to applicable models.
 - A special adapter fixing plate and box are required for the following models.
FXYCPKRP1B96

Names of parts

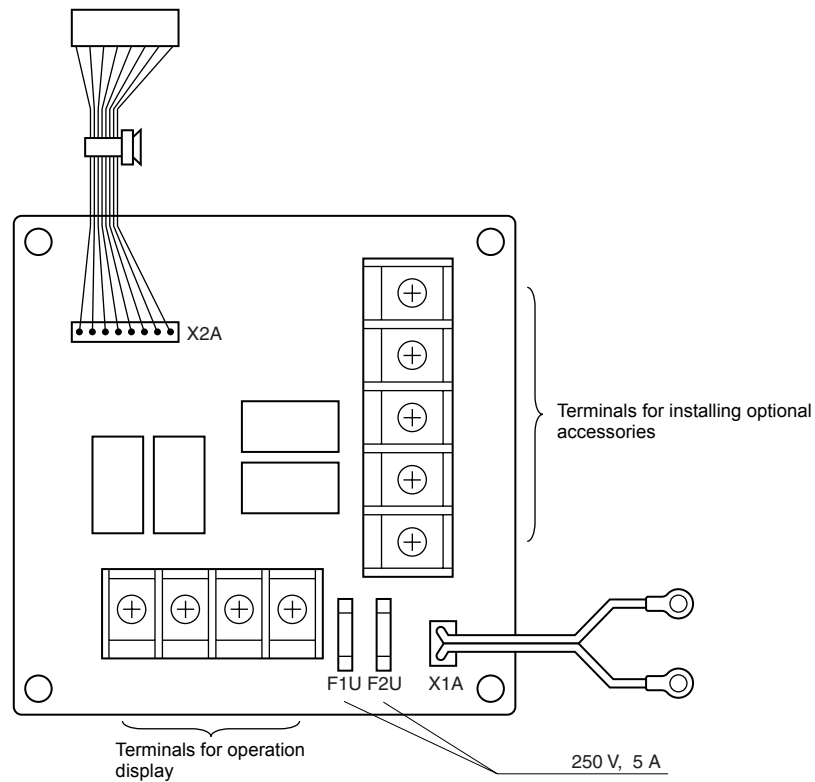

(HC0130)

7 Product Specification

7 - 2 Optional accessories

7-2-4 KRP1B61: Interlock adapter of VRV

Electric Wiring

- Refer to the WIRING DIAGRAM attached to the indoor unit before attempting to wire.
[Make sure wires to units do not pass over the PC board when wiring.]
- Wire the adapter to the indoor unit as shown below,

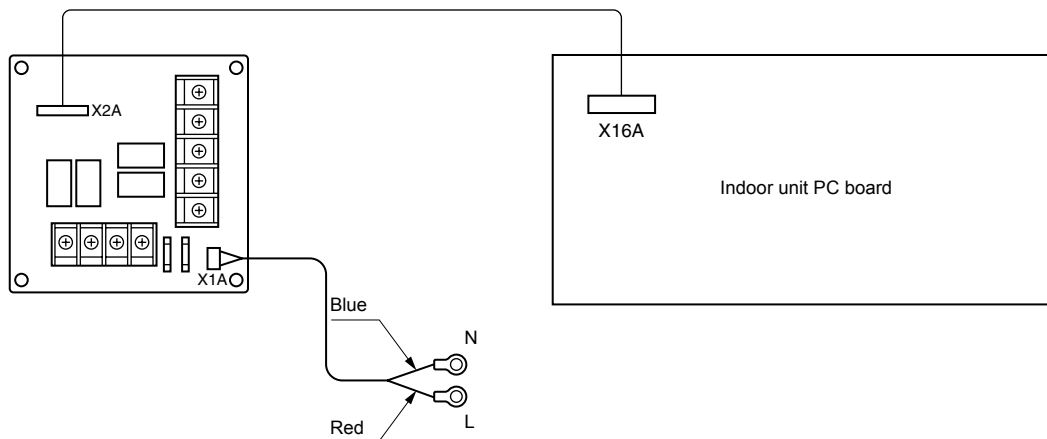

(HC0131)

1. Fetching the operation display signal

- Attaching an hour meter

Output is generated at the contact while the compressor is running.

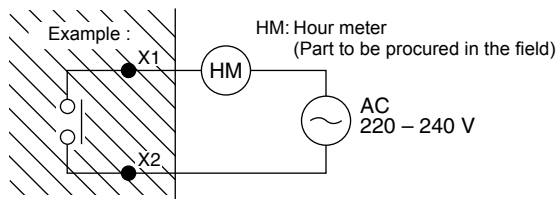

(HC0132)

- Fan ON display

Output is generated at the contact while the fan is running.

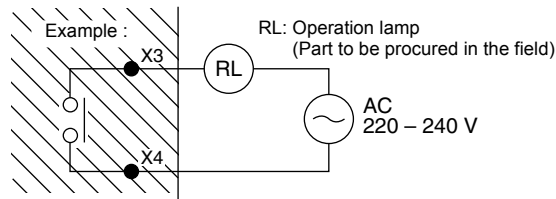

(HC0133)

2. If optional accessories are installed (auxiliary electric heater, humidifier)

- Wire correctly in accordance with the attached installation manual.
- Refer to the wiring diagram applied to the indoor unit when running electric wiring.

7 Product Specification

7 - 2 Optional accessories

7-2-4 KRP1B61: Interlock adapter of VRV

Installation

- Installation differs according to models.
- Do not bundle low and high voltage wires together.
- Bundle any access wires with the attached clamps so as to keep loose wirings off the indoor unit PC board.

Concealed ceiling unit

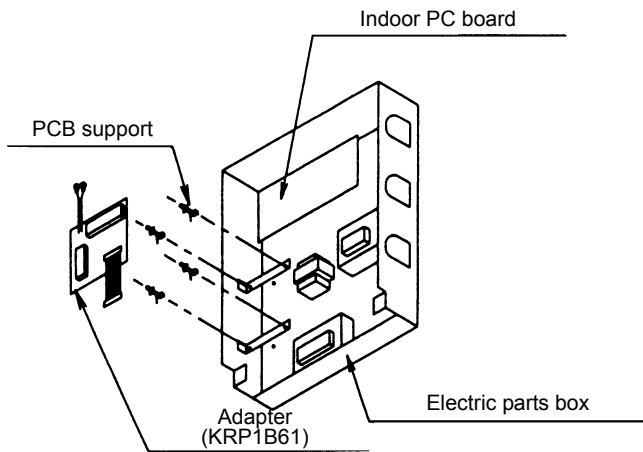

(HC0134)

Ceiling mounted corner cassette

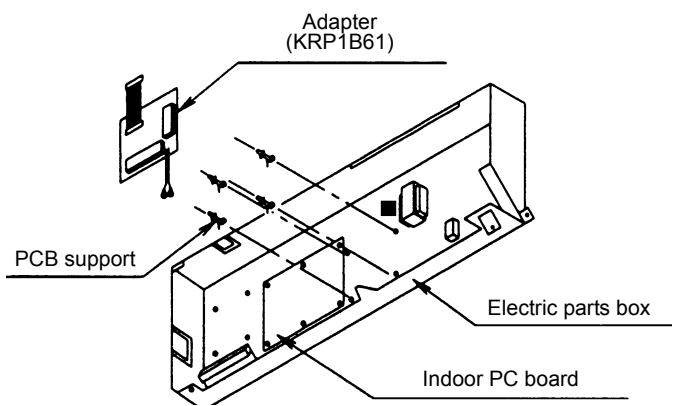

(HC0135)

2-way blow ceiling mounted cassette

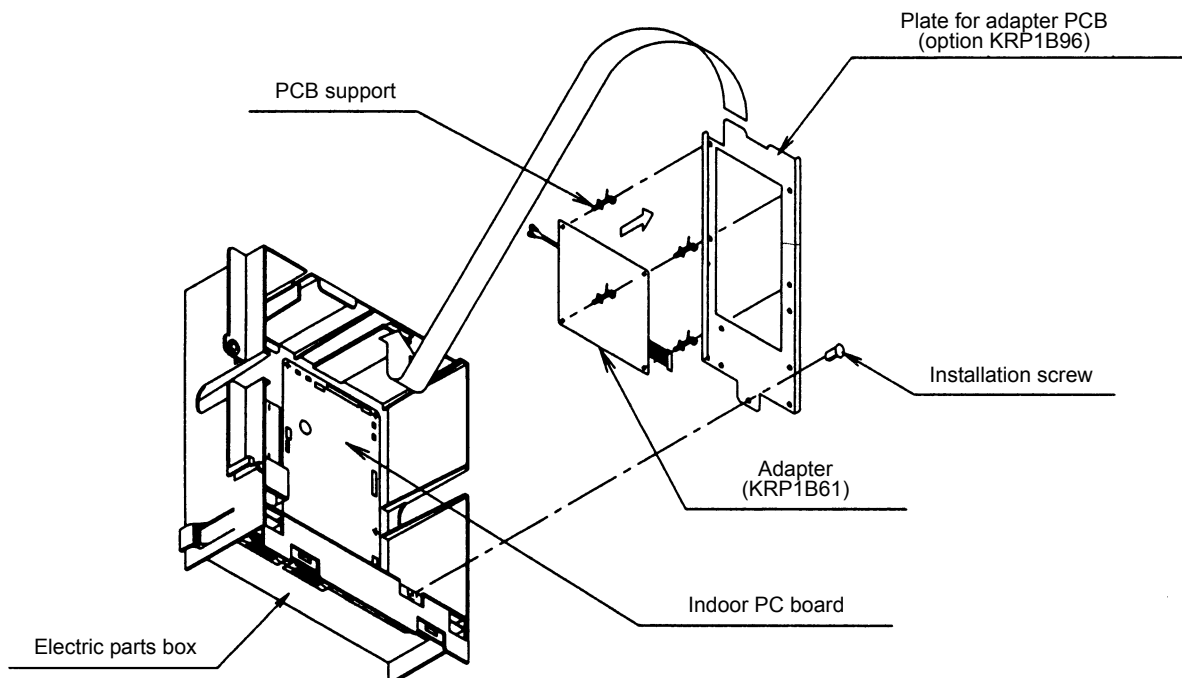

NOTE: A separate plate is needed to install the adapter PCB.

(HC0136)

7 Product Specification

7 - 2 Optional accessories

7-2-4 KRP1B61: Interlock adapter of VRV

Concealed ceiling unit (large)

40 ~ 125

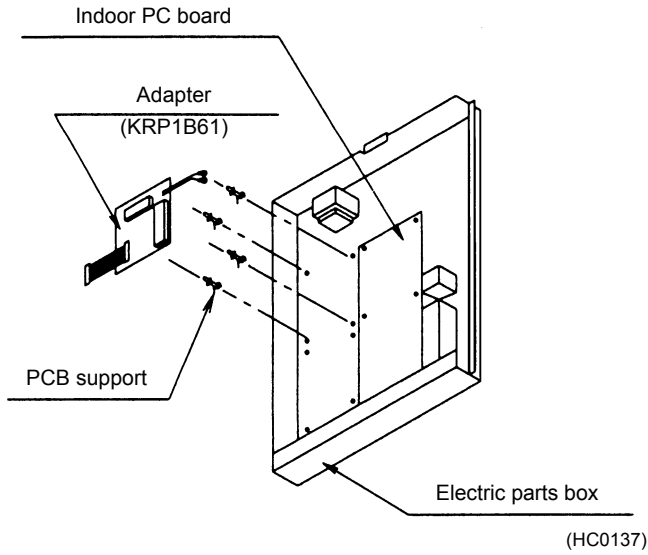

200 ~ 250

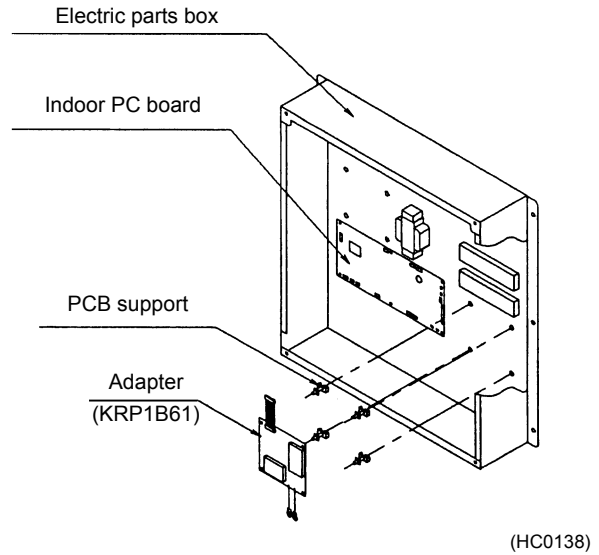

(Concealed) floor standing unit

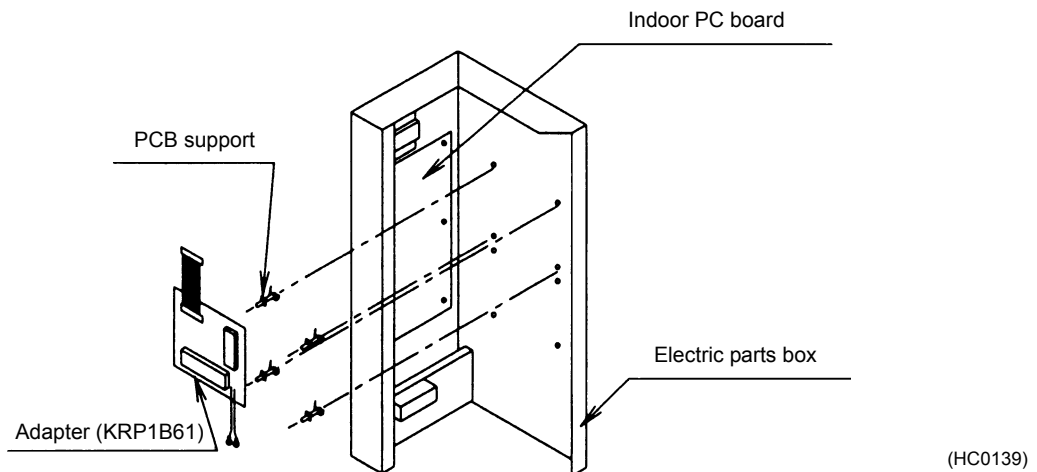

Ceiling suspended unit

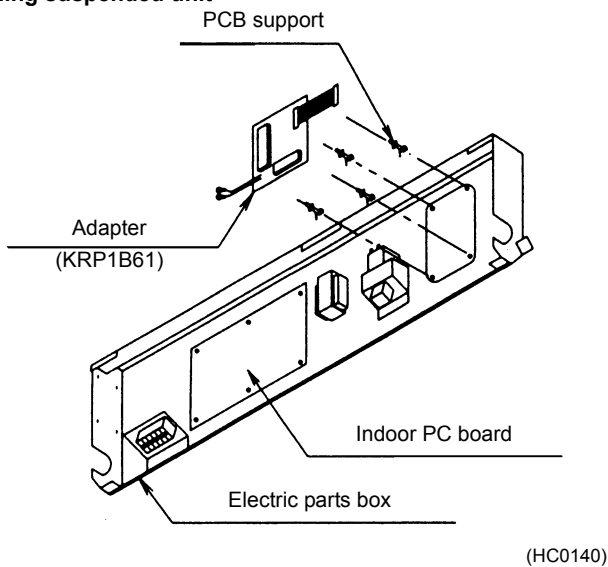

7 Product Specification

7 - 2 Optional accessories

7-2-5 KRP1B2: Interlock adapter of VRV

Contents of kit

Prior to installation check whether you have the complete kit of parts as shown below including the installation manual.

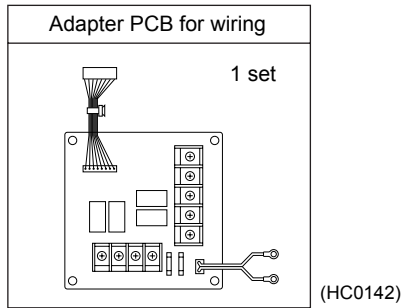

PC board support	4 pieces
Plastic straps	3 pieces
Installation manual	1 piece

Notes:

- Be careful with the selection of the optional kit, which varies depending on the model.
- For the installation of the following optional kit, it also requires the adapter fixing plate and box.
 FXYFP.....KRP1C98

Names of parts

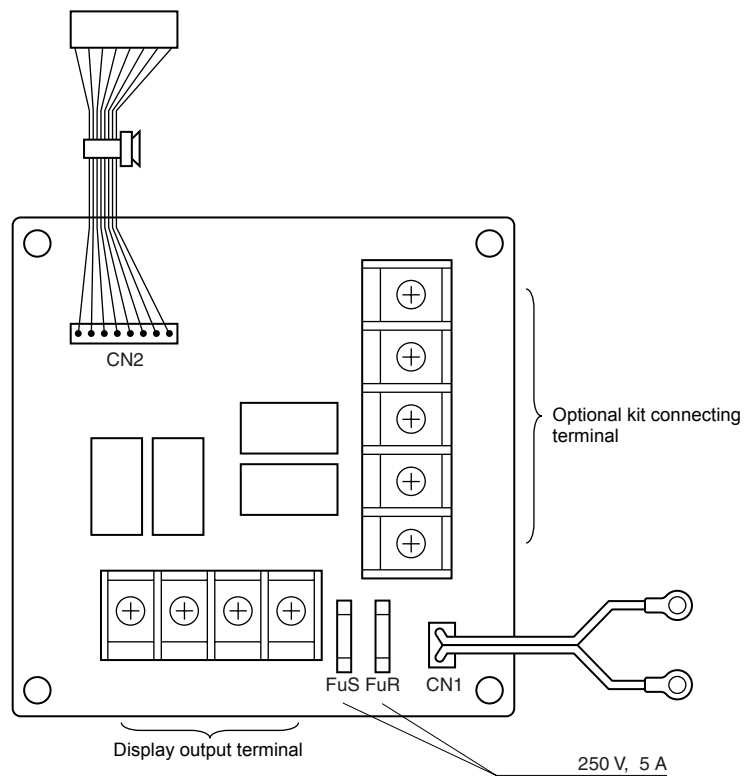

(HC0143)

7 Product Specification

7 - 2 Optional accessories

7-2-5 KRP1B2: Interlock adapter of VRV

Electrical wiring

- Refer to the wiring diagram of the indoor unit for its wiring connection. (Make sure all the wiring to the unit should not go over the PC board.)
- Connect the wiring to the indoor unit as shown below.

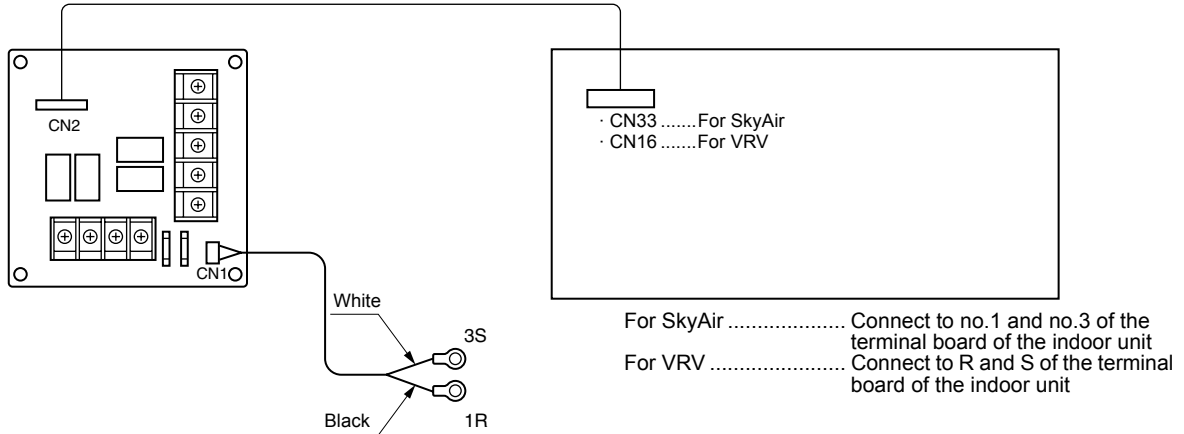

(HC0144)

1. To detect the operation display signal

- Installation of the watt-hour meter

Output signal to detect the operation of the compressor

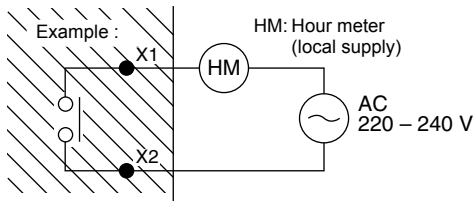

(HC0132)

- The fan display signal

Output signal to detect the operation of the fan

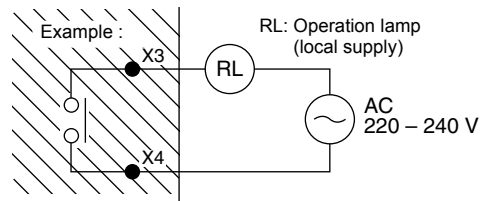

(HC0133)

2. In case other optional kits are installed. (auxiliary electric heater, humidifier and fresh air intake kit)

- Connect the wiring properly according to the installation manual included in the kit.
- Refer to the wiring diagram of the indoor unit for its wiring connection.

Installation

- Never bundle high and low voltage wiring together.
- Be sure to bundle the excess wiring with the attached plastic strap so as to keep the loose wiring off the indoor unit PC board.

4-way blow model

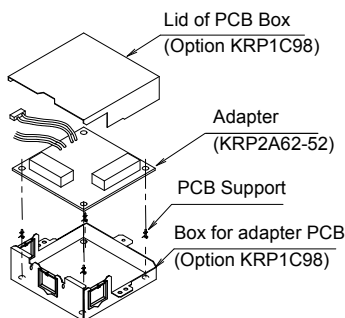

Note:

To install the adapter.
Box for adapter PCB (option) is required.

(HC0119)

7 Product Specification

7 - 2 Optional accessories

7-2-6 KRP1B3: Interlock adapter of VRV

Contents of kit

Prior to installation check whether you have the complete kit of parts as shown below including the installation manual.

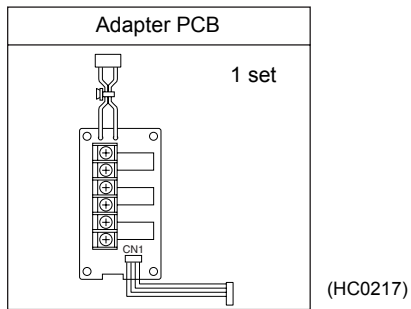

Plastic strap	3 pieces
Installation manual	1 piece

Name of parts

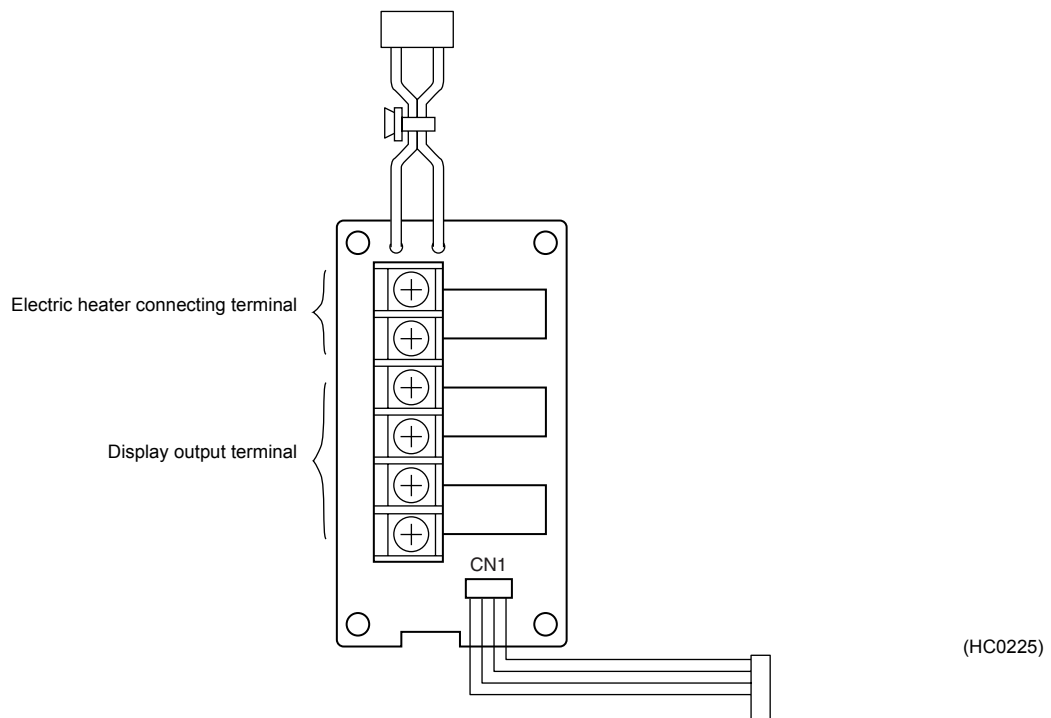

7 Product Specification

7 - 2 Optional accessories

7-2-6 KRP1B3: Interlock adapter of VRV

Electrical wiring

- Refer to the wiring diagram of the indoor unit for its wiring connection.
(Make sure all the wiring to the unit should not go over the PC board.)
- Connect the wiring to the indoor unit as shown below.

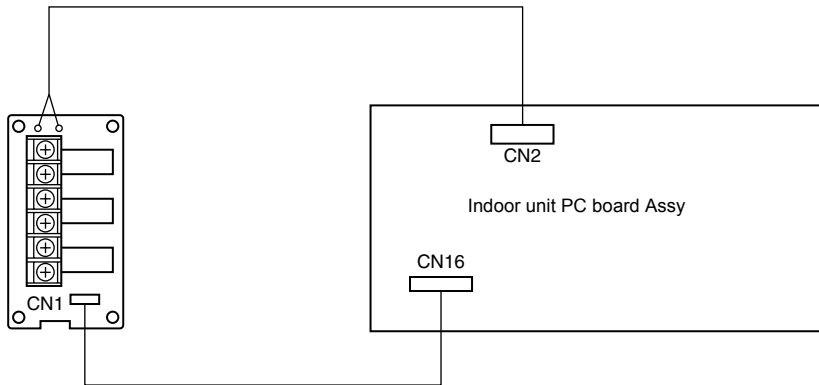

(HC0211)

1. To detect the operation display signal

- Installation of the watt-hour meter

Output signal to detect the operation of the compressor

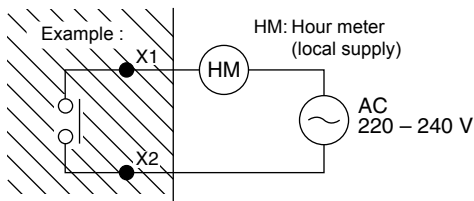

(HC0132)

- The fan display signal

Output signal to detect the operation of the fan

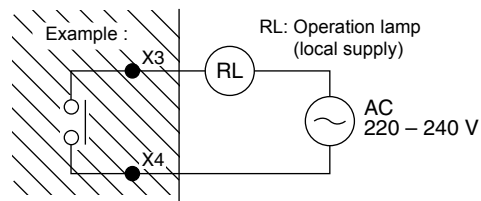

(HC0133)

2. In case the electric heater is installed

- Connect the wiring properly according to the installation manual included in the kit.
- Refer to the wiring diagram of the indoor unit for its wiring connection.

Installation

- Never bundle high and low voltage wiring together.
- Be sure to bundle the excess wiring with the attached plastic strap so as to keep the loose wiring off the indoor unit PC board.

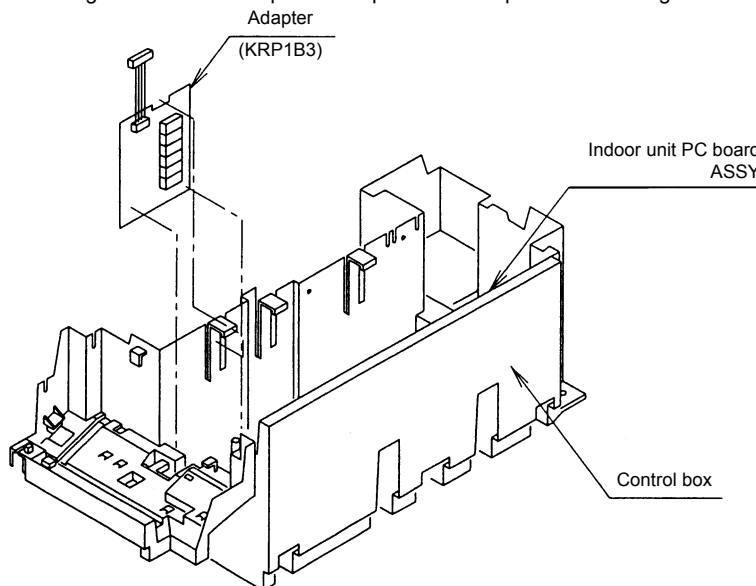

(HC0226)

7 Product Specification

7 - 2 Optional accessories

7-2-7 DCS302C51: Centralized control

- When using 1 central remote control

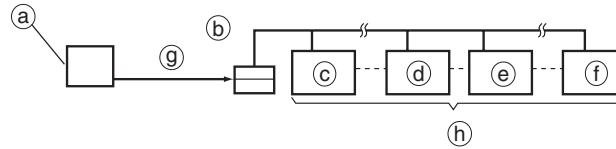

- When using 2 central remote controls

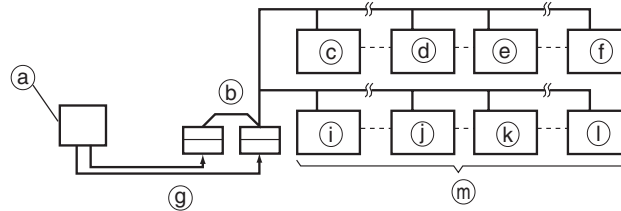

BEFORE USE: GENERAL DESCRIPTION OF SYSTEM

For a maximum of 64 groups of indoor unit unified operation/stop can be performed. When using 2 central remote controls, unified operation is possible with up to a maximum of 128 groups of indoor units. It can be used to set operation modes by ZONE: ON/OFF operation, operation controlled by timer ON/OFF control possible/ impossible; as well as, to set operating state: temperature setting, etc.
It can display the operation state such as operation modes and preset temperature by group.
Furthermore, the unit can be connected with an external key system or host computer monitor panel to enable forced ON/OFF input (no-voltage normally open contactor).
(This unit cannot be used concurrently with the adapter for electrical appendices [optional accessory].)

- Ⓐ Host computer monitor panel, etc.
- Ⓑ Central remote control
- Ⓒ Group No. 1 - 00
- Ⓓ Group No. 1 - 15
- Ⓔ Group No. 2 - 00
- Ⓕ Group No. 4 - 15
- Ⓖ Forced ON/OFF command
- (Stops with command from either central remote control)
- Ⓗ A maximum of 64 groups
- Ⓖ Group No. 5 - 00
- Ⓗ Group No. 5 - 15
- Ⓙ Group No. 6 - 00
- Ⓚ Group No. 8 - 15
- Ⓛ A maximum of 128 groups

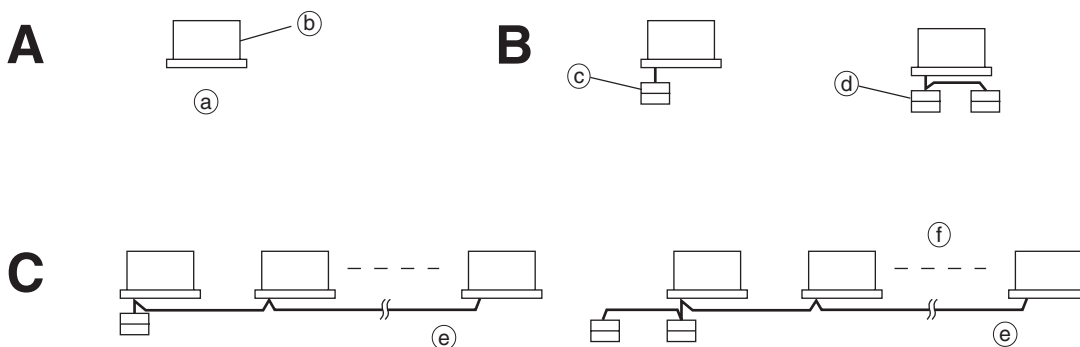

(HC0145)

7 Product Specification

7 - 2 Optional accessories

7-2-7 DCS302C51: Centralized control

* GROUP OF INDOOR UNIT refers to the above.			
A: A single indoor unit without remote control		B: A single indoor unit controlled by one or two remote control	
C: Maximum of 16 indoor units, group-controlled by one or two remote controls			
(a) Remote control not used	(b) Indoor unit	(c) Remote control	(d) Two remote controls
(e) A maximum of 16 units			

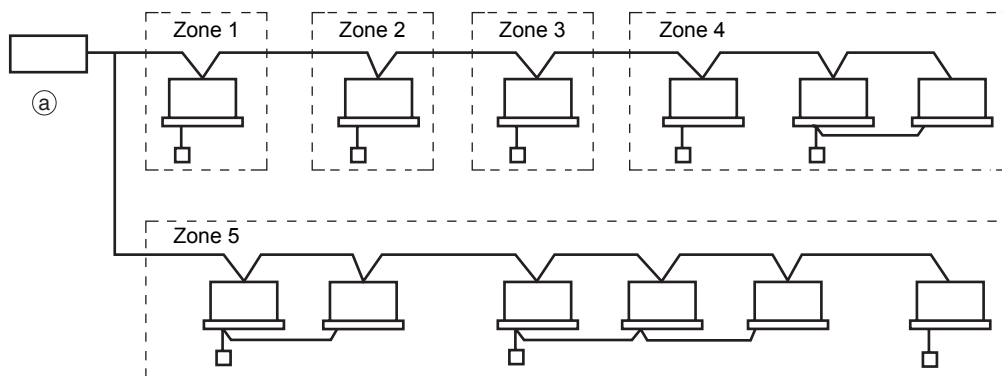

* Zone control from the central remote control	
Zone control is available from the central remote control. With it, it is possible to make unified settings for multiple groups, so setting operations are greatly simplified.	
<ul style="list-style-type: none"> • Any setting you make within a given zone will apply to all groups in the said zone. • A maximum of 64 zones can be set from a single central remote control. (Each zone contains a sum of 64 groups.) • Zones can be set randomly from the central remote control. 	
(a) Central remote control	

CAUTIONS DURING USE

- Do not tamper with the inner mechanism.
Do not remove the front panel. Tampering with the inner mechanism is dangerous and may damage equipment. For inspection and adjustment, contact your DAIKIN dealer.
- Avoid places where the unit may be contacted by water.
Water penetrating the inner mechanism may cause electrical leakage, or render electric parts defective.
- Do not press the button on the central remote control with a pointed hard tool.
This may damage the central remote control.
- Avoid direct exposure to sunlight.
Direct sunlight may discolor the LCD and obscure the image.
- Do not wipe the surface of the operation panel with benzene, thinner, chemically treated dust cloth, etc.
This may cause discoloring or peeling. To clean, moisten a cloth with a neutral cleanser diluted in water, rinse and wipe. Blot adhering water with a dry cloth.
- Never pull or twist the electric wire of a remote control.
It can cause the unit to malfunction.
- Never inspect or service the central remote control by yourself.
Ask a qualified service person to perform this work.

(HC0146)

7 Product Specification

7 - 2 Optional accessories

7-2-7 DCS302C51: Centralized control

Fig.1

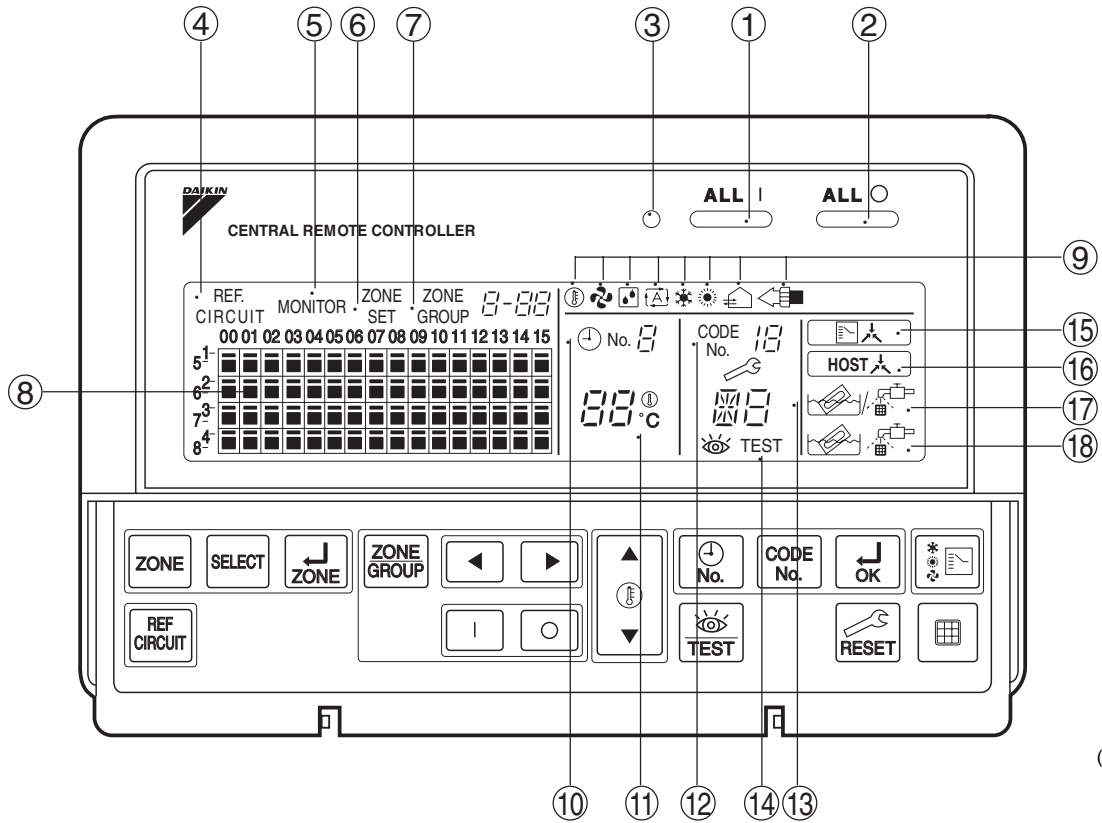
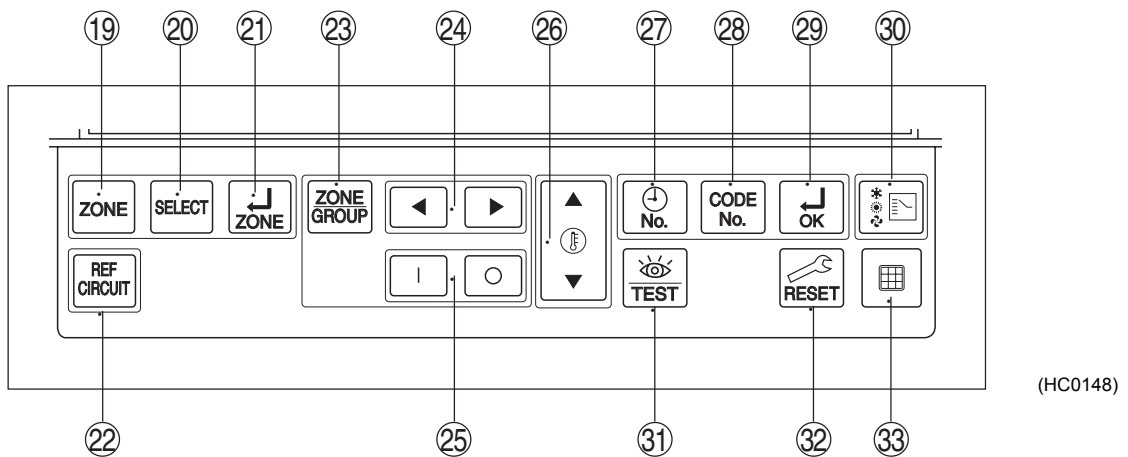

Fig.2



7 Product Specification

7 - 2 Optional accessories

7-2-7 DCS302C51: Centralized control

Fig. 3

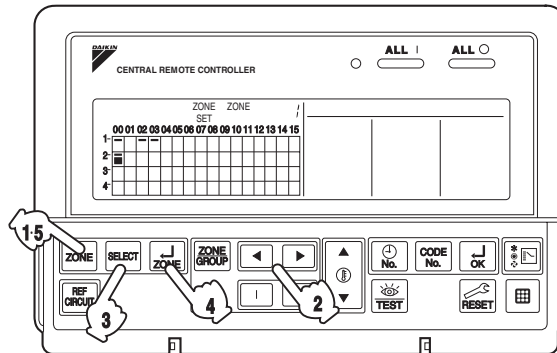

(HC0149)

Fig. 4

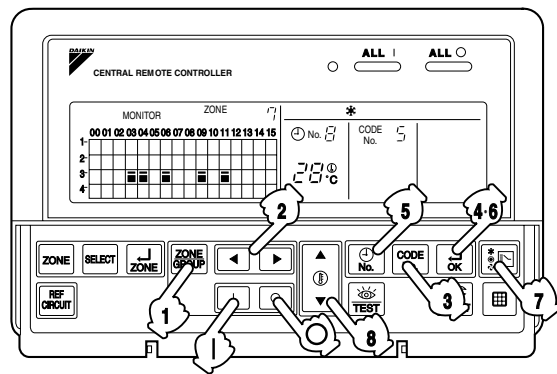

(HC0150)

Fig. 5

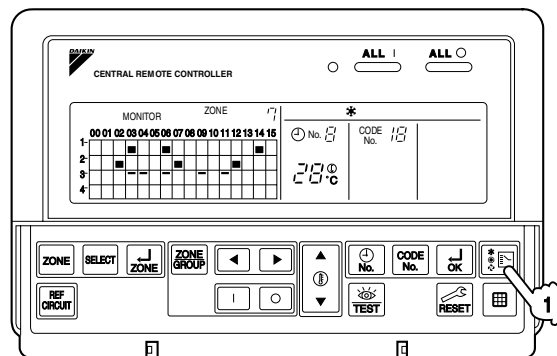

(HC0151)

Fig. 6

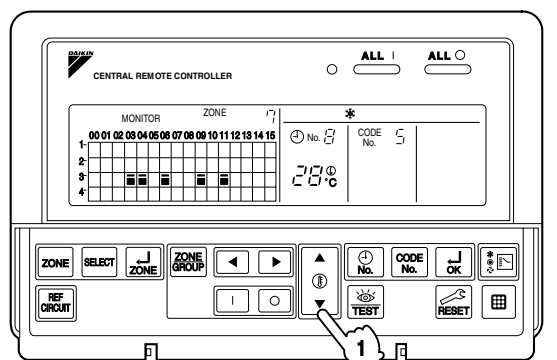

(HC0152)

7 Product Specification

7 - 2 Optional accessories

7-2-7 DCS302C51: Centralized control

**Fig.
7**

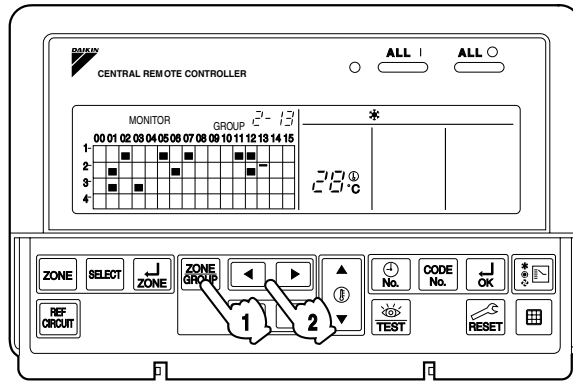

(HC0153)

**Fig.
8**

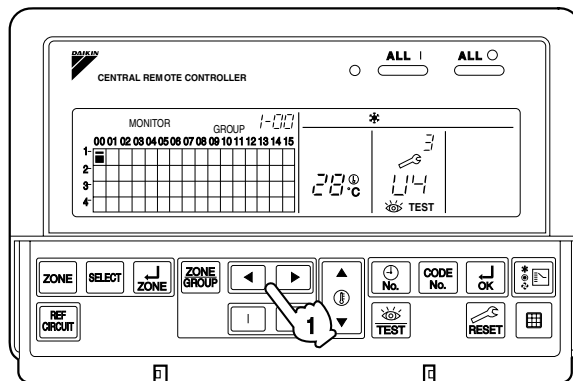

(HC0154)

**Fig.
9**

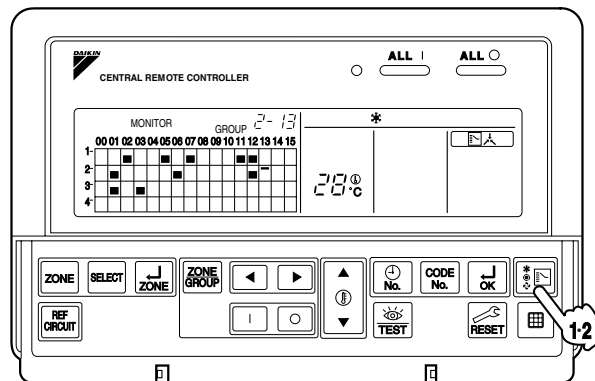

(HC0155)

7 Product Specification

7 - 2 Optional accessories

7-2-7 DCS302C51: Centralized control

Fig. 10

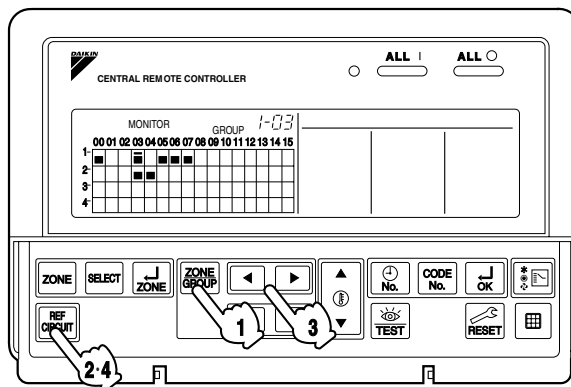

(HC0156)

Fig. 11

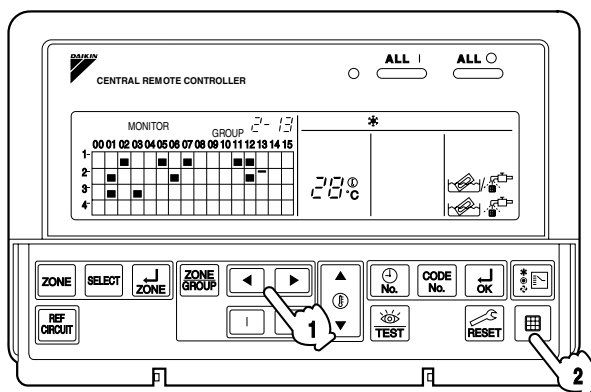

(HC0157)

Fig. 12

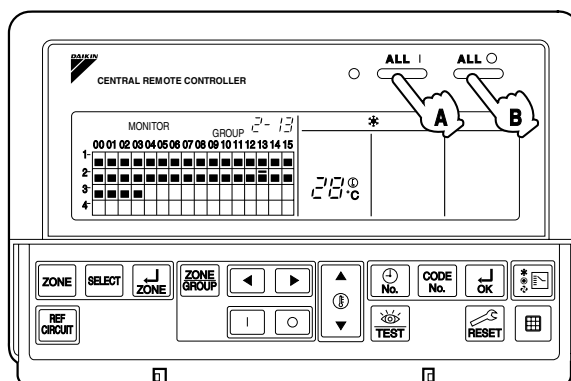

(HC0158)

7 Product Specification

7 - 2 Optional accessories

7-2-7 DCS302C51: Centralized control

FEATURES AND FUNCTIONS

■ Operation menu

This central remote control enables the individual operation/stop by zone, and unified operation/stop. ON/OFF operation controlled by timer is possible in conjunction with the schedule timer (optional accessory).



See page
50, 59

■ Various operation modes.

You can operate the system from both this unit and the remote control, so to enable various operation control patterns. Twenty different operation modes are available including five operation patterns: ON/OFF control impossible by remote control, only OFF control possible by remote control, centralized, individual and centralized (ON/OFF control possible by remote control only with the timer ON); and temperature setting possible/impossible by remote control and operation mode selecting possible/impossible by remote controller.



See page
52

■ Zone control for simpler operation

You can control a maximum of 64 groups of indoor units by using this central remote control. You don't have to repeat the same setting operations by group because you can make each of the following settings by zone.

Also, there is a function which allows you to unify settings in all groups. (When set to Zone No. 0, all the below settings are unified for all groups.)

- Operation mode
- Control mode
- Setting temperature
- Programming time No. (Used in conjunction with the schedule timer)



See page
49

■ Monitor and display operating conditions of indoor units by group

You can display operating conditions such as operation mode and preset temperature; maintenance information such as time to clean, etc.; and information on trouble such as malfunction codes.

* "Time to clean" sign refers to the following functions.

- Display the time to clean air filter and the air cleaner element of electric dust collector for each group.
- Display the time to clean when signaled from any given group.



See page
56

■ Function of refrigerant system display

This display helps you understand, at a glance, the indoor units sharing the same outdoor unit and the particular indoor unit among them that is set as the master remote control.



See page
58

- Utilizing one of the PC board adapters (optional accessories) will enable you to combine this unit with the split. A/C units and unitary A/C.

















However, be sure to refer to the installation manual attached to each PC board adapter for function limitations.

(HC0159)

7 Product Specification

7 - 2 Optional accessories

7-2-7 DCS302C51: Centralized control



<h1 style="text-align: center;">NAMES AND FUNCTIONS OF THE OPERATING SECTION (Fig. 1,2)</h1>			
①	UNIFIED OPERATION BUTTON Press to operate all indoor units.	⑩	 "No." DISPLAY (TIME NO.) Displays the operation timer No. when used in conjunction with the schedule timer.
	UNIFIED STOP BUTTON Press to stop all indoor units.		⑪ " °C" DISPLAY (PRESET TEMPERATURE) Displays the preset temperature.
③	OPERATION LAMP (RED) Lit while any of the indoor units under control is in operation.	⑫	" 18" DISPLAY (CONTROL MODE) Displays codes on how to control equipment (ON/OFF control impossible by remote control, centralized, individual etc.). Displays the No. of the particular unit that has stopped due to malfunction.
	" " DISPLAY (REFRIGERANT SYSTEM DISPLAY) The indication in the square is lit while the refrigerant system is being displayed.		⑬ " " DISPLAY (MALFUNCTION CODE) Displays the contents of a malfunction. The lamp flashes when a malfunction stops operation. The contents of the current malfunction are displayed in the inspection mode.
⑤	" " DISPLAY (OPERATION MONITOR) The lamp is lit while operation is being monitored.	⑭	" TEST" DISPLAY (INSPECTION/TEST) Press the inspection/test operation button. Either the inspection or test lamp lights up.
	" " DISPLAY (ZONE SETTING) The lamp is lit while setting zones.		⑮ " " DISPLAY (CHANGEOVER UNDER CONTROL) Cool/heat selection is not possible for either the zone or the group where this particular display appears.
⑦	"ZONE" "GROUP" DISPLAY (ZONES/GROUP) Indicates the particular zone or group being displayed.	⑯	" " DISPLAY (UNDER HOST COMPUTER INTEGRATED CONTROL) Setting is not possible while this display is being displayed.
	GROUP NO. IN OPERATION Each square displays the state corresponding to each group.		⑰ " " DISPLAY (TIME TO CLEAN) Displayed to notify the user it is time to clean the air filter or air cleaner element of a particular group.
⑨	" " " " " " " " " " " " " DISPLAY (OPERATION MODE) Displays operating state. 	⑰	
	Displays operating state.		

(HC0160)

7 Product Specification

7 - 2 Optional accessories

7-2-7 DCS302C51: Centralized control

⑱	“” “” DISPLAY (TIME TO CLEAN AIR CLEANER ELEMENT/ TIME TO CLEAN AIR FILTER)	⑳	TEMPERATURE SETTING BUTTON
	Displayed to notify the user it is time to clean the air filter or air cleaner element of the group displayed.		Press to set temperature.
㉑	ZONE SETTING BUTTON	㉒	TIME NO. BUTTON
	Turns zone setting mode ON/OFF.		Selects time No. (Use in conjunction with the schedule timer only).
㉓	SELECTOR BUTTON	㉔	CONTROL MODE BUTTON
	Selects the group to be assigned to a zone.		Selects control mode.
㉕	ZONE OPERATION ON/OFF BUTTON	㉖	TIMER ON BUTTON
	Finalizes the zone.		Sets control mode and time No.
㉗	BUTTON FOR REFRIGERANT SYSTEM DISPLAY	㉘	OPERATION MODE SELECTOR BUTTON
	See page 58.		See page 57.
㉙	ZONE/GROUP CHANGEOVER BUTTON	㉚	INSPECTION/TEST OPERATION BUTTON
	Switches display “zone” to display “group” or vice versa.		Press to run inspection or test run.
㉛	ADVANCE/BACKWARD BUTTON	㉜	CLEARING BUTTON FOR MALFUNCTION CODE MEMORY
	See page 49.		Press to clear malfunction code.
㉝	ON/OFF BUTTON	㉞	FILTER SIGN RESET BUTTON
	Starts/stops operation by zone.		See page 58.
Notes: <ol style="list-style-type: none"> Please note that all the displays in the figure appear for explanation purposes or when the cover is open. If the unit is used in conjunction with other optional central controllers, the OPERATION LAMP of the unit that is not under operation control may light up and go out a few minutes behind schedule. This shows that the signal is being exchanged, and does not indicate any failure. 			

(HC0161)

7 Product Specification

7 - 2 Optional accessories



7-2-7 DCS302C51: Centralized control

ZONE SETTING (Fig. 3)

You can set multiple groups under a single zone to control them by zone. This equipment is factory set for 64 zones of 1 group per every zone at the time of shipment.

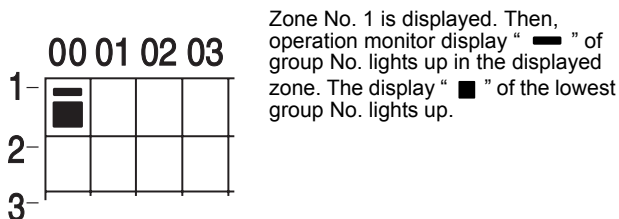
1 Press the ZONE SETTING BUTTON, and "  " is displayed.



Zone No. 1 is displayed. Then, operation monitor display "  " of group No. lights up in the displayed zone. The display "  " of the lowest group No. lights up.

2 Press the ADVANCE/ BACKWARD BUTTON to move the display "  " to the group of the desired zone. Holding the button down will quickly move the display.

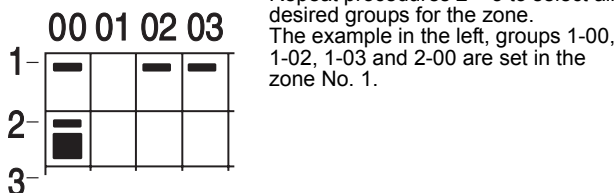

3 Press the SELECTOR BUTTON to set the above group in the zone. The display "  " of the selected group lights up.

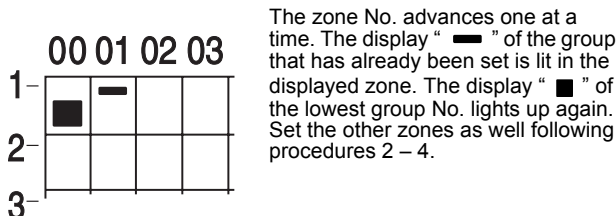

Repeat procedures 2 – 3 to select all desired groups for the zone. The example in the left, groups 1-00, 1-02, 1-03 and 2-00 are set in the zone No. 1.

4 Press the ZONE OPERATION ON/OFF BUTTON to finalize the zone. This zone becomes finalized, and the next zone No. is displayed.





The zone No. advances one at a time. The display "  " of the group that has already been set is lit in the displayed zone. The display "  " of the lowest group No. lights up again. Set the other zones as well following procedures 2 – 4.

In the above example, the zone No. 2 is displayed. Then, the display "  " of the lowest group No. that has already been set lights up.

5 Press the ZONE SETTING BUTTON again, to finish zoning. The current display goes out, and the normal display appears.

NOTES

To clear all registered zones Display "  ". Then, hold down both "  " and ALL j for about 4 seconds. This will clear all registered zones.

- If you have set a group in the wrong zone, reset it in the correct zone. (The last zone set is judged to be effective.)
- You cannot set the same group in multiple zones.
- When you turn ON the power, the system may display " " for approximately one minute and may not respond to operation until all the liquid crystal display appears.
- Unless operated from within one minute from when the display of zoning appears, the display will automatically revert back to the "group" display.
- A single setting will simultaneously determine the same setting of all the groups in the zone. So, pay attention to the following points in setting the zone.
 1. The control mode must be the same for all groups in the zone.
 2. The scheduled operation must be the same for all groups in the zone, if the operation is controlled by the timer.
 3. The cool/heat operation mode must be the same for all groups in the zone.
 4. The preset temperature must be the same for all groups in the zone.

Note:

Be sure to select the " - - " in executing the operation by zone, as well as to set the operation mode and the temperature setting unless the uniform operation is performed in the above 3 and 4. (See page 114.)

(HC0162)

7 Product Specification

7 - 2 Optional accessories

7-2-7 DCS302C51: Centralized control

OPERATION

OPERATION BY ZONE (Fig. 4)

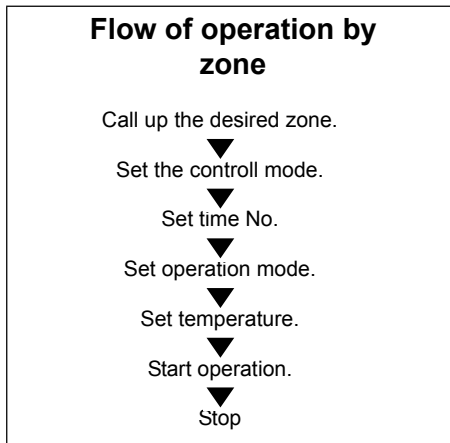

1 Press the ZONE/GROUP CHANGEOVER BUTTON, to call up the display of zoning.

	00	01	02	03	04	05	06	07	08	09	10	11	12	13	14	15
1																
2																
3																
4																

The display “ — ” of the group set in the display zone lights up.

2 Press the ADVANCE/ BACKWARD BUTTON, to select the zone No. Holding it down will quickly move the display.

3 Press the CONTROL MODE BUTTON, to call up the desired code No. (See page 116.) Following the change, the display flashes.
Setting is not possible when using a data station or parallel interface.

4 Press the TIMER ON BUTTON. Press the TIMER ON BUTTON within 10 seconds after the code No. is displayed. The display stops flashing and lights up solidly.

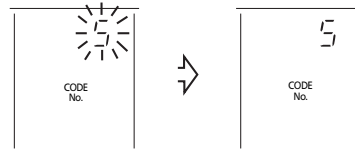

The display returns to its original state after no less than 10 seconds.

(only in conjunction with the schedule timer)

5 Press the TIME No. BUTTON, to select the desired time No.. When you change the setting, the display flashes. If you don't wish to program the “-”.

Check the timer No. of the schedule timer. If the schedule timer is not programmed, set the program in accordance with the instruction manual of schedule timer.

6 Press the TIMER ON BUTTON, to finalize the time No. The display flashes, and then lights up solidly. Press the TIMER ON BUTTON within 10 seconds after the time No. is displayed.

The display returns to its original state after no less than 10 seconds.

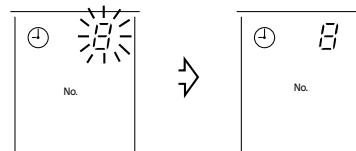

7 Press the OPERATION MODE SELECTOR BUTTON, to call up the desired mode. If you don't wish to execute the unified setting in the zone, set it to “ - - ”. (See page 121 for further details.)

(HC0163)

7 Product Specification

7 - 2 Optional accessories

7-2-7 DCS302C51: Centralized control

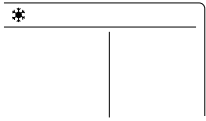

Cooling mode is selected.



Unified operation is not set within the zone.



8 Press the TEMPERATURE SETTING BUTTON.

Each time you press the “▲”, the temperature rises by 1°C.

Each time you press the “▼”, the temperature falls by 1°C.

If you don't wish to execute the unified setting in the zone, set it to “--”.

(See page 122 for further details.)

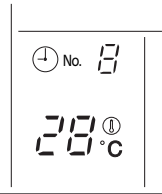

28 C is selected.

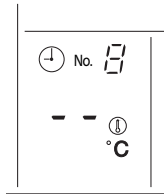

Unified operation is not set within the zone.

(When execute operation/stop by zone)



9 Press the ON BUTTON. The operation lamp lights up, and then the display “■” of the corresponding group appears.

MONITOR		ZONE.	17
	00 01 02 03 04 05 06 07 08 09 10 11 12 13 14 15		
1-			
2-			
3-	■ ■ ■ ■ ■ ■ ■ ■		
4-			



10 Press the OFF BUTTON.

Unless operated from within one minute from when the display of zoning appears, the display will automatically revert back to the “group” display.

7 Product Specification

7 - 2 Optional accessories

7-2-7 DCS302C51: Centralized control

OPERATION MODE

The following five operation control modes can be selected along with the temperature setting and operation mode by remote control, for a total of twenty different modes. These twenty modes are set and displayed with control modes of 0 to 19. (For further details, see EXAMPLE OF OPERATION SCHEDULE on the next page.)

- ON/OFF control impossible by remote control
Use this mode when operating and stopping from the central remote control only. (ON/OFF control by the remote control is disabled.)
- Only OFF control possible by remote control
Use this mode when executing the operation only by the central remote control, and executing only the stop by remote control.
- Centralized
Use this mode when executing the operation only by the central remote control, and executing operation/stop freely by remote control during the preset hours.
- Individual
Use this mode when executing operation/stop both by central remote control and remote control.
- Timer operation possible by remote control
Use this mode when executing operation/stop by remote control during the preset hours, and not starting operation by the central remote control at the programmed time of system start.

HOW TO SELECT THE CONTROL MODE

Select whether to accept or to reject the operation from the remote control regarding the operation, stop, temperature setting and operation mode setting, respectively, and determine the particular control mode from the rightmost column of the table below.

Example

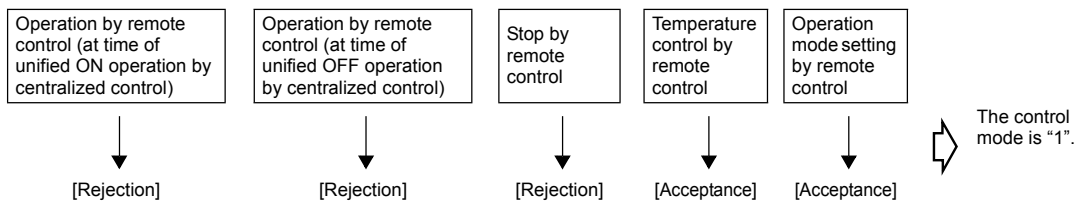

Operation mode	Control by remote control					Control mode
	Operation		Stop	Temperature control	Operation mode setting	
	Unified operation, individual operation by central remote control, or operation controlled by timer	Unified stop, individual stop by central remote control, or timer stop				
ON/OFF control impossible by remote control	Rejection (Example)	Rejection (Example)	Rejection (Example)	Rejection	Acceptance	0
				Rejection	Rejection	10
				Acceptance (Example)	Acceptance (Example)	1 (Example)
				Acceptance (Example)	Rejection	11
Only OFF control possible by remote control	Rejection (Example)	Rejection (Example)	Acceptance	Rejection	Acceptance	2
				Rejection	Rejection	12
				Acceptance	Acceptance	3
				Acceptance	Rejection	13

(HC0165)

7 Product Specification

7 - 2 Optional accessories

7-2-7 DCS302C51: Centralized control

Operation mode	Control by remote controller					Control mode	
	Operation			Stop	Temperature control		Operation mode setting
	Unified operation, individual operation by central remote control, or operation controlled by timer	Unified stop, individual stop by central remote control, or timer stop					
Centralized	Acceptance	Rejection (Example)	Acceptance	Rejection	Acceptance	4	
Individual					Rejection	14	
					Acceptance	5	
Timer operation possible by remote control					Rejection	15	
					Acceptance	6	
Individual					Rejection	16	
	Acceptance	7					
Timer operation possible by remote control	Rejection	17					
	Acceptance	8					
Individual	Rejection	18					
	Acceptance	9					
Timer operation possible by remote control	Rejection	19					
	Acceptance	19					

Note:

Do not select the timer operation possible without the remote control. In this case, timer operation is disabled.

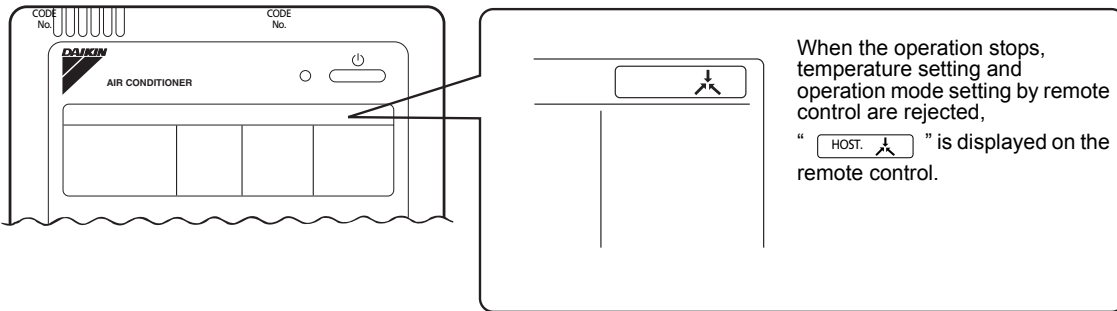

EXAMPLE OF OPERATION SCHEDULE

Operation schedule is possible only in conjunction with the schedule timer (optional accessory).

Liquid crystal display of schedule timer

ON/OFF control impossible by remote control

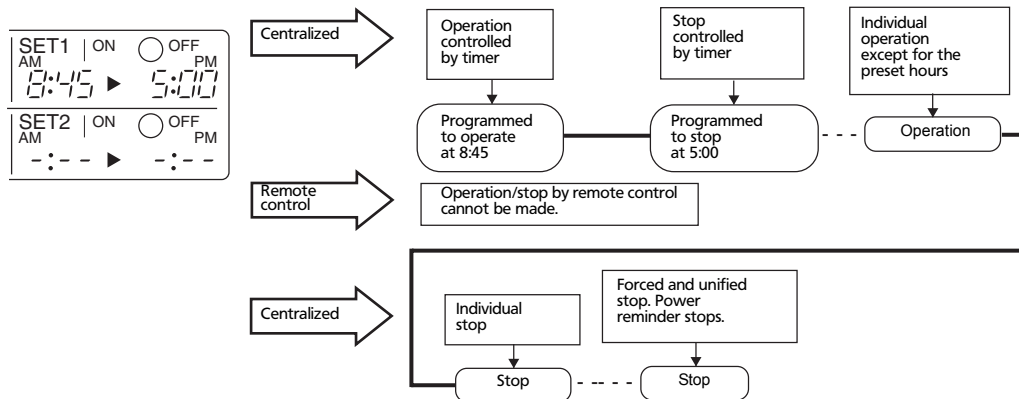

(HC0166)

7 Product Specification

7 - 2 Optional accessories

7-2-7 DCS302C51: Centralized control

ON/OFF control possible by remote control

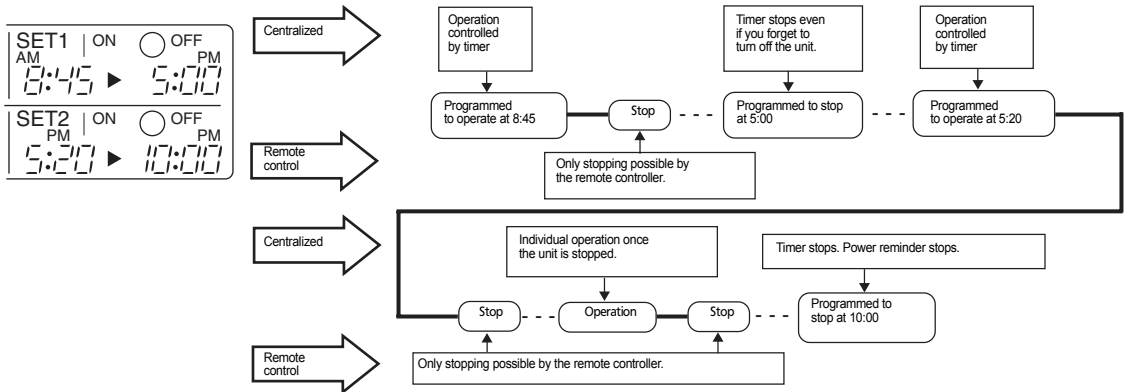

Centralized

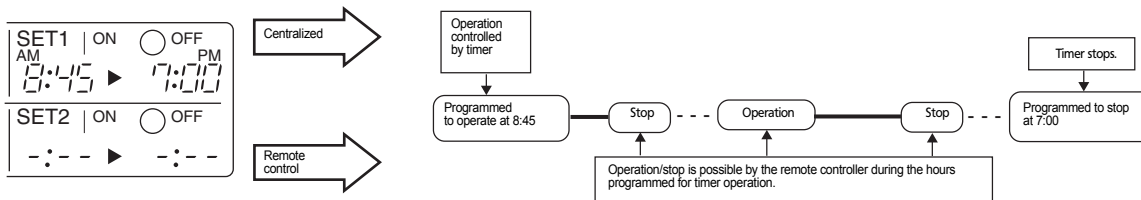

Individual

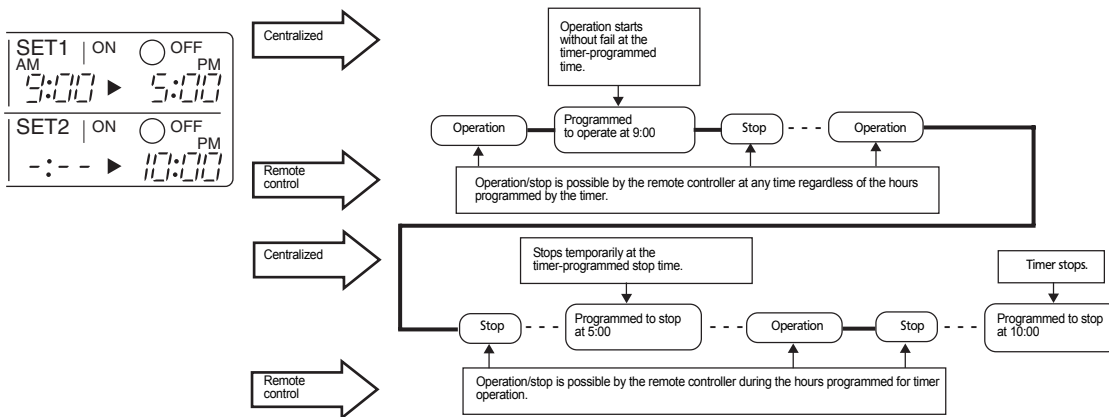

Timer operation possible by remote control

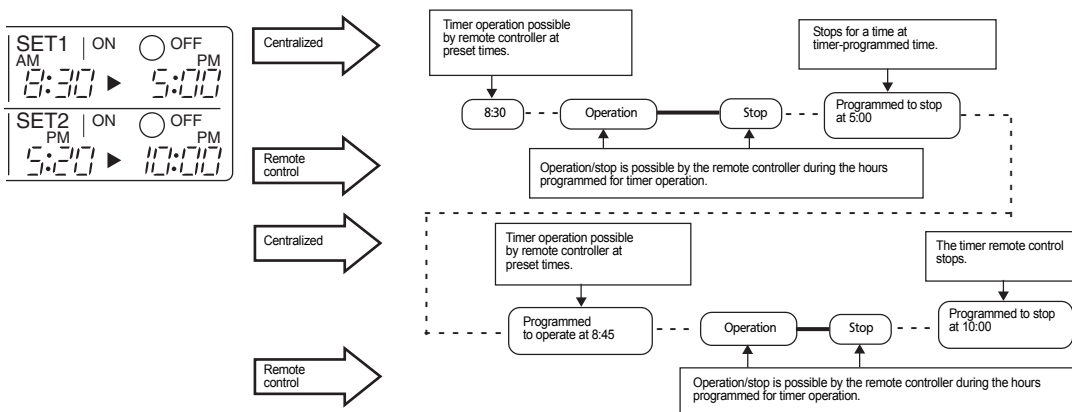

- Air conditioner now OPERATING.
- - - - Air conditioner now stopping.
- ▭ Command by central remote control.
- Command by remote control.

(HC0167)

7 Product Specification

7 - 2 Optional accessories

7-2-7 DCS302C51: Centralized control

SETTING OPERATION MODE (Fig. 5)

- The Zone consists of the following two cases.

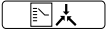
A. Zone without display “”
 The group with master remote control setting exists in this zone.
 Setting the master remote control enables cool/heat selection.
 Operations other than cool/heat operations can also be set for some operations. For further details, see the list on the right.

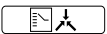
B. Zone with display “”
 No group with master remote control setting exists in this zone.
 The cool/heat selection is not available because the master remote control has not been set.
 Some operations other than cool/heat operations can be set. For further details, see the list in the right.

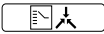







See page 121 if the display “” is flashing.









1 Press the OPERATION MODE SELECTOR BUTTON.
 Each time you press this button, the display rotates as shown on the right list.

NOTES:

- During cool/heat operation, this central remote control enables FAN operation for each zone even without setting the master remote control. Meanwhile, ventilation, ventilation/cleaning, etc. are available, if HRV etc. are connected with this unit in the zone. See the operation manual provided with the each unit.
- When the indoor unit is in heat operation, change the setting to FAN operation through the central remote control; then, you can switch the fan speed to the extremely low fan speed. Warm air may blow if any other indoor unit belonging to the same system is in heat operation.
- The indoor fan stops during defrost/hot start.
- DRY cannot be set from the central remote control.

• List of setting operation

Display	A: Zones not displayed	
	Setting	Contents of setting
	×	
	○	To be set by zone
	○ * 1	To be set by zone
	○	To be set by zone
	○	To be set by zone
	○ * 1	To be set by zone
	○ * 1	To be set by zone
	○	Select this display if you don't wish to set by zone.

Display	B: Zones not displayed	
	Setting	Contents of setting
	○	* 2
	○	To be set by zone
	×	
	×	
	×	
	○ * 1	To be set by zone
	○ * 1	
	○	Select this display if you don't wish to set by zone.

Note:

In the above list, “○” refers to the acceptable setting, while “×” refers to the not acceptable setting.
 In the meanwhile, * 1 and * 2 refer to the followings:
 * 1: Setting may not be acceptable depending on the type of indoor unit with which this unit is connected.
 * 2: The group on FAN operation in the zone performs the temperature control operation (cool/heat) under the outdoor refrigerant system.

(HC0163)

7 Product Specification

7 - 2 Optional accessories

7-2-7 DCS302C51: Centralized control

TEMPERATURE SETTING (Fig. 6)

1 Press the **TEMPERATURE SETTING BUTTON**.

Each time you press the “▲”, the temperature rises by 1°C.

Each time you press the “▼”, the temperature falls by 1°C.

If you don't wish to set the temperature in a unified manner in the zone, set the temperature to “--”.

NOTES:

- The setting temperature refers to that of the temperature sensing part. (It may differ from the room temperature.)
- The proper setting temperature is 26°C – 28°C during cooling operation, and 18°C – 23°C during heating operation.
- The setting temperature is not displayed in the FAN mode and Ventilation/Cleaning mode. The set temperature is not displayed either if HRV etc. form a zone without an air conditioner.

If you wish to set the temperature to “--”

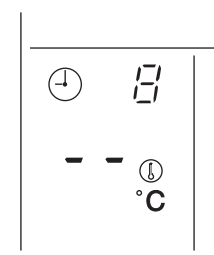

(Example)

In case where the range of temperature to be set is – 32°C

Press the “▼” when the display shows 16°C. The display “--” appears.

Press the “▲” when the display shows 32°C. The display “--” appears.

Set the temperature at the point 1°C higher than the upper limit and 1°C lower than the lower limit of the range

subject to setting, respectively.

GROUP MONITORING (Fig. 7)

Utilize the group monitor function in each of the following cases:

1. Check the malfunction code. (See the next page.)
2. Check the group that requires cleaning of the air filter and air cleaner element. (See page 125.)
3. Change the setting of the master remote control. (See page 124.)
4. Check the group(s) sharing the same outdoor unit.
Or, check the particular group(s) with the master remote control setting. (See page 125.)
5. Check the conditions of other individual groups.

1 Press the **ZONE/GROUP CHANGEOVER BUTTON** on the display of zoning, and the display “group” appears.

Unless operated from within one minute from when the display of zoning appears, the display will automatically revert back to the “group” display.

2 Press the **ADVANCE/BACKWARD BUTTON** to set the group No. Then, operation monitor display “■” of group No. lights up in the displayed zone; then, the state of the above group(s) is displayed in the liquid crystal display.

(HC0169)

7 Product Specification

7 - 2 Optional accessories

7-2-7 DCS302C51: Centralized control

ERROR DIAGNOSING FUNCTION (Fig. 8)

This central remote control is provided with a diagnosing function, for when an indoor unit stops due to malfunction. In case of actuation of a safety device, disconnection in transmission wiring for control or failure of some parts, the operation lamp, inspection display and unit No. start to flash; then, the malfunction code is displayed. Check the contents of the display, and contact your DAIKIN dealer because the above signs can give you the idea on the trouble area.

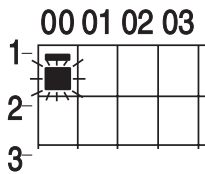

The display “  ” flashes under the group No. where the indoor unit that has stopped due to malfunction.

1 Press the RETURN/ADVANCE BUTTON to call up the group that has stopped due to malfunction.

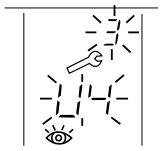



The unit No. that has stopped due to malfunction and the malfunction code flashes. The display of control mode is replaced by that of the unit No.

SETTING MASTER REMOTE CONTROL (Fig. 9)

You must set the master remote control of the operation mode for one of the indoor units, if two or more such indoor units with the remote control are connected with the outdoor unit where the operation modes such as cool/heat operation and FAN operation can be set by remote control and central remote control.





1 • Check the particular group with the master remote control setting for the refrigerant system you wish to reset. (See the right.)

- Call up the group without the display “  ” (See page 136.) Hold the OPERATION MODE SELECTOR BUTTON down for about four seconds while the above group is being called up.

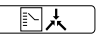

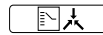
The display “  ” flashes on the liquid crystal display of the remote control for all the groups sharing the same outdoor unit or BS unit.

When you turn on the power switch for the first time, the display “  ” flashes.

2 Call up the desired group to set the master remote control, and press the OPERATION MODE SELECTOR BUTTON. The master remote control is set for this group, and the display “  ” goes out. The display “  ” appears for the other groups. Setting is finished now.

- In case of operation switch
Call up the zone including the group with the setting of master remote control.
(Zone without the display “  ”)
Press the OPERATION MODE SELECTOR BUTTON several times, and switch to the desired operation mode. Each time you press it, the display is switched to “  ” “  ” “  ” and “  ” in sequence.

NOTES

- Press the ZONE/GROUP CHANGEOVER BUTTON, and call up the display of zoning.
- However, the displays “  ” “  ” and “  ” may appear in some zones, depending on the type of indoor unit with which they are connected.

(HC0170)

7 Product Specification

7 - 2 Optional accessories

7-2-7 DCS302C51: Centralized control

FUNCTION OF REFRIGERANT SYSTEM DISPLAY (Fig. 10)

The following information becomes available by utilizing this function.

- Indoor group connected with the same outdoor unit
- Indoor group with the master remote control setting of the given refrigerant system

1 Press the ZONE/GROUP CHANGEOVER BUTTON, and call up the display “group” if the display of zoning appears. Unless operated from within one minute from when the display of zoning appears, the display will automatically revert back to the “group” display.

2 Press the BUTTON FOR REFRIGERANT SYSTEM DISPLAY. The display “ ” appears.

3 Press the ADVANCE/ BACKWARD BUTTON to call up the group of which you wish to check the refrigerant system.

	00	01	02	03	04	05	06	07
1-	■		■	■	■	■	■	■
2-			■	■				
3-								

The display “ ■ ” of all the groups sharing the same refrigerant system as the group on display flashes. Then, the display “ ■ ” of the particular group among them with the master remote control setting flashes. Repeat the

procedure 3 if you wish to check other refrigerant systems as well. The above example shows that the groups 1-00, 1-03, 1-05, 1-06, 1-07, 2-03 and 2-04 share the same refrigerant system, and also that the master remote control is provided with group 1-03.



4 Press the BUTTON FOR REFRIGERANT SYSTEM DISPLAY again. The display “ ” goes out. The refrigerant system display is finished now.



NOTES



- Unless operated from within one minute from when the refrigerant system displays, the display will automatically revert back to the “group” display.
- This function may not be available depending on the type of outdoor unit with which the unit is connected. In this case, the display “ ” flashes.

DISPLAY OF TIME TO CLEAN (Fig. 11)

This central remote control displays the time to clean the air filter or air cleaner element for each group or any given group by utilizing two types of signs.



The display “  /  ” tells the time to clean the air filter or the air cleaner element of some group.

1 Press the ADVANCE/ BACKWARD BUTTON, and search the groups displaying “  ” or “  ” (Several groups may have this indication.)

Clean or change the air filter or air cleaner element. For further details, see the operation manual attached to each indoor unit. (Clean or change the air filter or air cleaner element of all the groups displaying “  ” or “  ”.)

2 Press the FILTER SIGN RESET BUTTON, and the display “  /  ” disappears. (Including all the groups where the air filter has been cleaned.)

NOTE

Be sure to check the display “  /  ” has disappeared at this point. The appearance of the above display is a sign that the air filter or air cleaner element of some groups still needs cleaning.

(HC0171)

7 Product Specification

7 - 2 Optional accessories

7-2-7 DCS302C51: Centralized control

UNIFIED OPERATION (Fig. 12)

Use this function when executing operation and stop of all the connected indoor units.

A Unified operation

Press the UNIFIED OPERATION BUTTON. All the displays “ — ” of the group No. in operation light up at the same time, and all the groups start to operate at the same time.

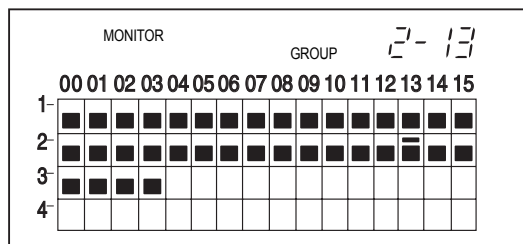

B Unified stop

Press the UNIFIED STOP BUTTON. The lights of every display “ — ” of group No. in operation go out at the same time; then, the lights of all the groups stop at the same time.

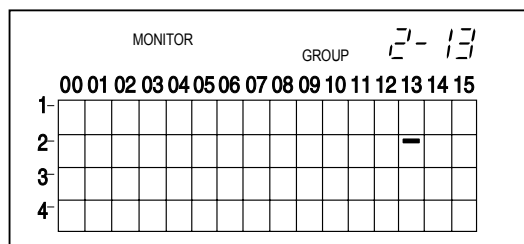

- When using the central remote control in conjunction with other optional controllers for centralized control, the OPERATION LAMP on controllers which are not being used for operation may delay a few minutes before lighting or going out. There is nothing wrong with the equipment. The delay is due to signal exchange.

7 Product Specification

7 - 2 Optional accessories

7-2-7 DCS302C51: Centralized control

OPTIONAL ACCESSORIES

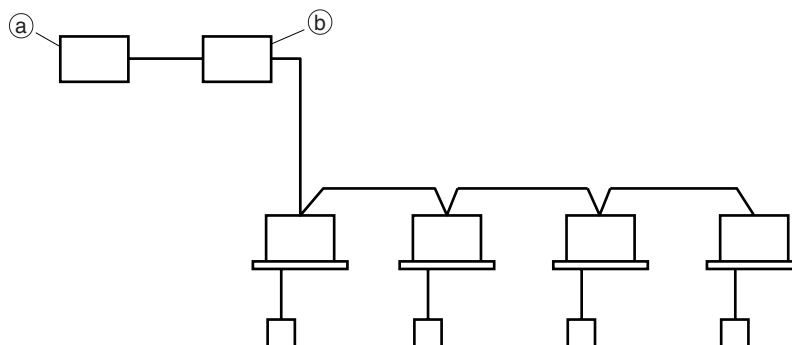

You can perform the normal operation, take off the malfunction contact point and unified operation/stop by contact point, all by connecting this unit with the unification adapter for computerized control. For further details, ask your DAIKIN dealer.

(a) Unification adapter for computerized control

(b) Central remote control

DOUBLE CENTRAL REMOTE CONTROLS

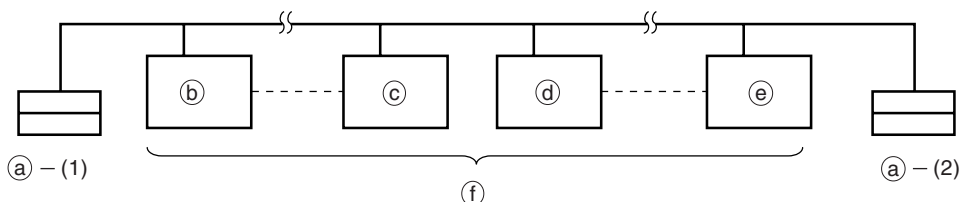

With two central remote controls, centralized control (indoor units) is possible from different locations.

(a) Central remote control

(b) Group No. 1-00

(c) Group No. 1-15

(d) Group No. 2-00

(e) Group No. 4-15

(f) Maximum 64 groups

Note:

- For control alignment and settings for double central remote control, contact your DAIKIN dealer.

(HC0173)

7 Product Specification

7 - 2 Optional accessories

7-2-7 DCS302C51: Centralized control

SPECIFICATIONS

■ Specifications

Power supply	Single phase, 50 / 60 Hz, 220 – 240 V / 220 V
Power consumption	Max. 4.5 W
Forced ON / OFF input	Continuous “a” contact Contact current: approximately 10 mA
Size	180 (W) x 120 (H) x 64.5 (D)
Weight	430 g

■ Outline drawings

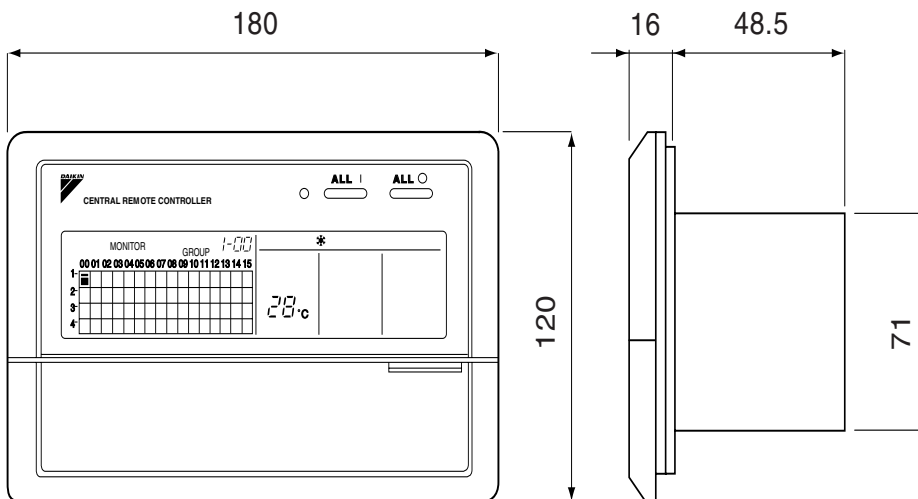

Specifications and appearance of this unit subject to change without notice.

(HC0174)
3PA63363-1
EM96A021

7 Product Specification

7 - 2 Optional accessories

7-2-8 DCS301B61: Unified ON / OFF control

NAMES AND FUNCTIONS

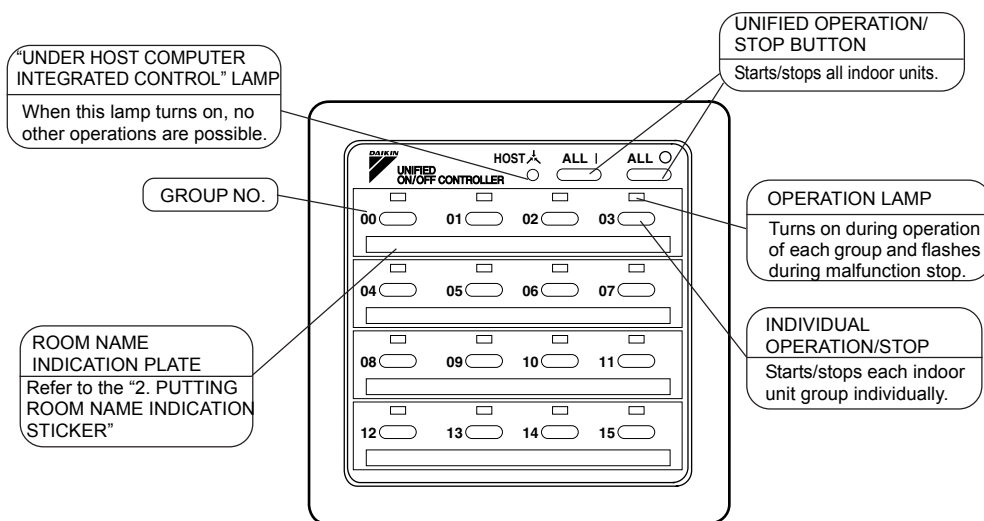

<< NOTE >>

- When using unified ON/OFF controller with other optional controllers for centralized control, "OPERATION LAMP" of the equipment which is not operated may turn on or off after several minutes. This state occurs due to signal communications and is not a failure.
- Do not open the upper part of remote control except when rewriting the indication sticker or selecting control modes.

PUTTING ROOM NAME INDICATION STICKER

<p>① Open the upper part of remote control. Insert a (-) screwdriver into the recess between the upper and lower part of remote control (at 2 locations) and twist the screwdriver lightly.</p>	<p>(-) screwdriver (2 locations)</p>
<p>PC board is attached both the upper and lower part of remote control. Do not damage the board with the screwdriver.</p>	
<p>② Pull out the room name indication plate. Insert the point of a mechanical pencil etc. into the hole of the indication sticker to pull it out.</p>	<p>Indication plate Control mode selector (DS2)</p>

(HC0190)

7 Product Specification

7 - 2 Optional accessories

7-2-8 DCS301B61: Unified ON / OFF control

③ Put the attached indication sticker on the room name indication plate.

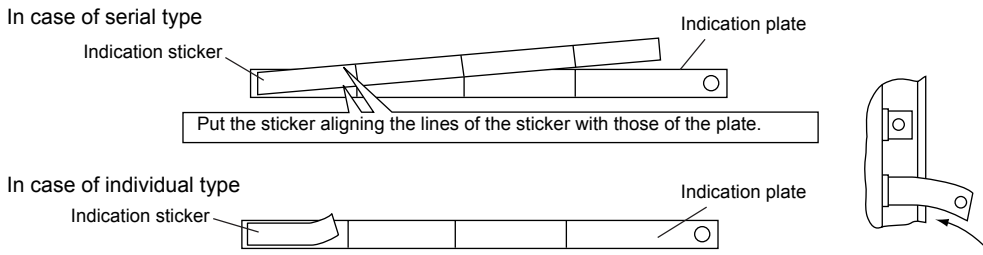

Put the sticker on the center of the frame.
Write the room name in the frame of the sticker with a ball point pen or a felt-tip pen (oil-base).

- ④ Reinstall the plate as it was, with checking the correct direction.
- ⑤ Close the upper part of remote control.

SELECTING CONTROL MODES

The following four patterns of control mode can be set.

Control mode	Individual	Centralized	Timer operation possible by remote control	ON/OFF control impossible by remote control
Content	Operation/stop is controlled by both unified ON/OFF control and remote control.	After operated by unified ON/OFF controller, operation/stop is freely controlled by remote control until stopped by unified ON/OFF controller.	When used in conjunction with schedule timer, operation/stop is controlled freely by remote control during the set time but operation is not available when schedule timer is ON.	Operation/stop is controlled by unified ON/OFF controller only. Indoor units can not be operated/stopped by remote control.
DS2 setting				

NOTE:

- ■ indicates the position of switches.
- Set control modes before turning power supply on.
- When used in conjunction with central remote control, the control modes of the central remote control has the priority.

DISPLAY OF MALFUNCTION

Flashing of lamps indicates malfunctions. Contact your Daikin dealer.
When turning power supply on, all lamps may light and UNDER HOST COMPUTER INTEGRATED CONTROL lamp may flash and not accept the operation for about one minute.
These conditions are not malfunctions.

States of lamps	Contents of malfunctions
Flashing of operation lamp	Indicates malfunctions in the indoor unit in the group where the operation lamp is flashing.
Flashing of UNDER HOST COMPUTER INTEGRATED CONTROL lamp	Indicates malfunctions in optional controllers for centralized control.

(HC0191)

3PA53843

7 Product Specification

7 - 2 Optional accessories

7-2-9 DST301B61: Schedule timer

CAUTIONS DURING USE

- Do not tamper with the inner mechanism.
Do not remove the front panel. Tampering with the inner mechanism is dangerous and may damage equipment. For inspection and adjustment, contact your DAIKIN dealer.
- Avoid places where the unit may be contacted by water.
Water penetrating the inner mechanism may cause electrical leakage, or render electric parts defective.
- Do not press the button on the LCD with a pointed hard tool.
This may damage the LCD.
- Avoid direct exposure to sunlight.
Direct sunlight may discolor the LCD and obscure the image.
- Do not wipe the surface of the operation panel with benzene, thinner, chemically treated dust cloth, etc.
This may cause discoloring or peeling. To clean, moisten a cloth with a neutral cleanser diluted in water, rinse and wipe. Blot adhering water with a dry cloth.
- Never pull or twist the electric wire of the schedule timer.
It can cause the unit to malfunction.
- Never inspect or service the schedule timer by yourself.
Ask a qualified service person to perform this work.

FEATURES AND FUNCTIONS

- **Operation controlled by programmed time**
Operating time and stopping time can be set to the minute by each day of the week. The operating and stopping patterns can also be set in schedule according to the time slot given twice a day in tune with the uses.



See page
68

- **Unified Operation/Stop**
By using this schedule timer, the unified operation/stop of the indoor unit can be executed manually regardless of the No. of programmed time in operation.



See page
70

- **When used in conjunction with central remote control (Optional Accessory)**

The operation controlled by programmed time can be set for up to eight different patterns (timer No. 1 – 8). Each schedule pattern can also be selected.

(HC0175)

7 Product Specification

7 - 2 Optional accessories

7-2-9 DST301B61: Schedule timer

Fig.1

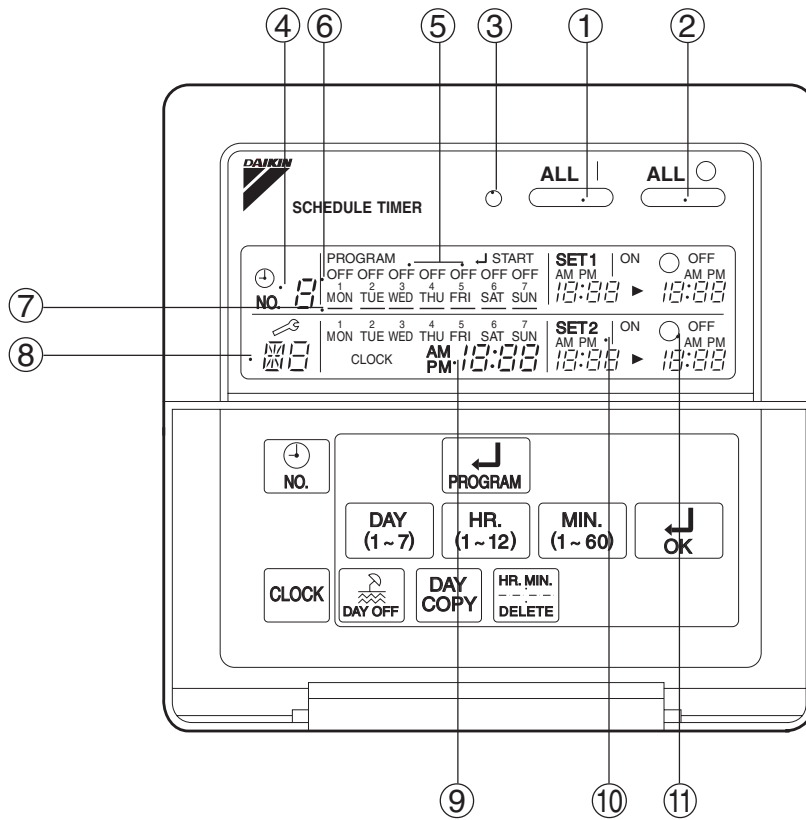

(HC0176)

Fig.2

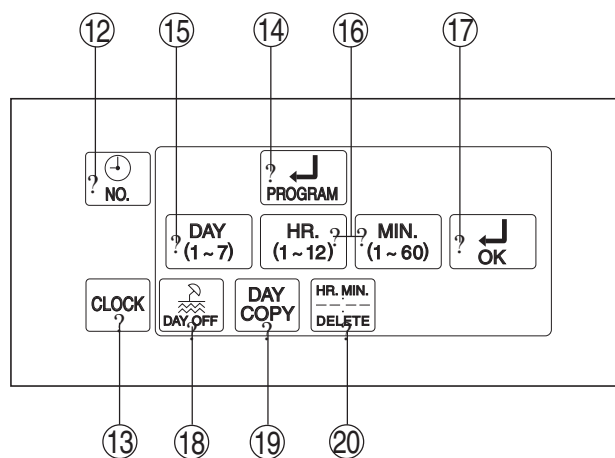

(HC0177)

7 Product Specification

7 - 2 Optional accessories

7-2-9 DST301B61: Schedule timer

Fig. 3

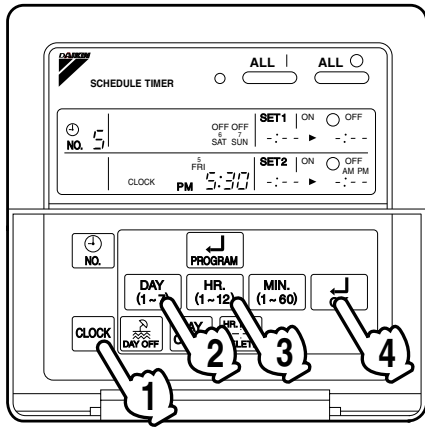

(HC0178)

Fig. 4

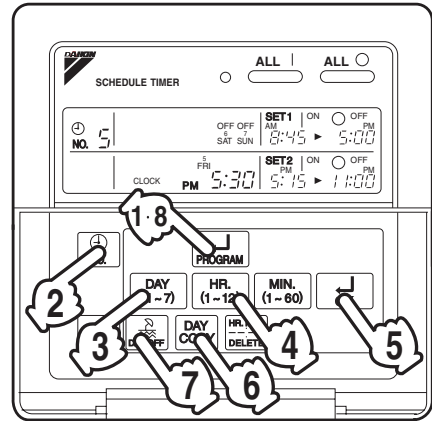

(HC0179)

Fig. 5

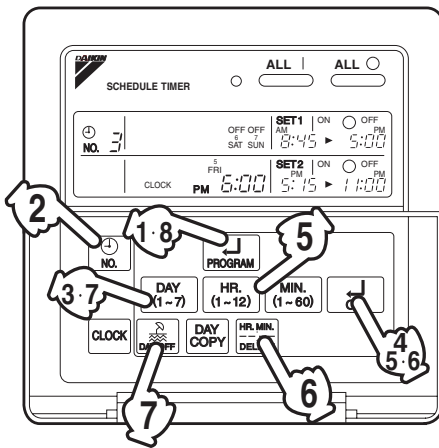

(HC0180)

Fig. 6

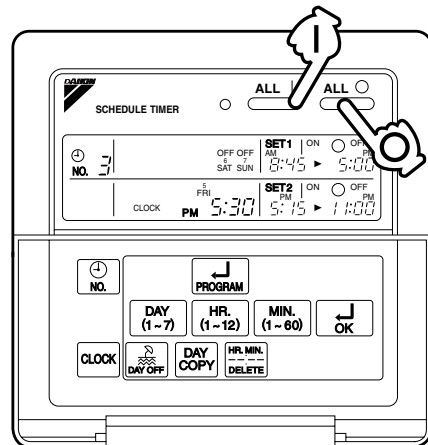

(HC0181)

Fig. 7

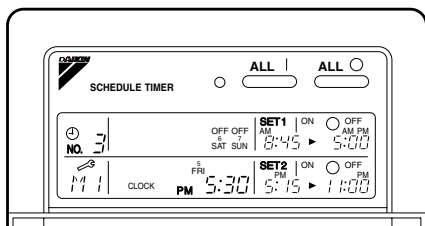







(HC0182)

7 Product Specification

7 - 2 Optional accessories

7-2-9 DST301B61: Schedule timer

NAMES AND FUNCTIONS OF THE OPERATING SECTION (Fig. 1,2)

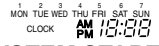
①	UNIFIED OPERATION BUTTON	⑪	DISPLAY “” (PROGRAMMED TIME OF SYSTEM OFF)
	Press this button to perform the unified operation regardless of the No. of programmed time.		Displays the time programmed to stop.
②	UNIFIED STOP BUTTON	⑫	TIME NO. BUTTON
	Press this button to perform the unified stop regardless of the No. of programmed time.		
③	OPERATION LAMP (RED)	⑬	CLOCK ADJUSTING BUTTON
	The light turns on during the operation of the indoor unit.		Press this button to set the present time.
④	DISPLAY “” (TIME NO.)	⑭	PROGRAMMING START BUTTON
	Displays the time No. only when used in conjunction with the central remote control.		Press this button to set or check the No. of programmed time. Press it again after you are through with the program.
⑤	DISPLAY “PROGRAM  START.” (PROGRAMMING START)	⑮	BUTTON FOR SELECTING DAYS OF A WEEK
	The light turns on when the timer is programmed.		Press this button to select the day of the week.
⑥	DISPLAY “” (HOLIDAY SETTING)	⑯	HOURLY/MINUTE BUTTON
	Lights above the day of the week set as holiday. The operation controlled by timer is not available on that day.		Press this button to adjust the present time and the programmed time.
⑦	DISPLAY “-” (SETTING OF DAYS OF A WEEK)	⑰	TIMER ON BUTTON
	Flashes below the day of the week programmed.		Press this button to set the present time and the programmed time.
⑧	DISPLAY “” (MALFUNCTION CODE)	⑱	HOLIDAY SETTING BUTTON
	Displays the contents of malfunction during the stop due to malfunction.		Press this button to set holidays.
⑨	DISPLAY “” (PRESENT TIME)	⑲	BUTTON FOR COPYING PROGRAM OF PREVIOUS DAY
	Displays the present day of the week and time.		Use this button to set the No. of programmed time same as that of the previous day.
⑩	DISPLAY “” (PROGRAMMED TIME OF SYSTEM START)	⑳	PROGRAM CANCELING BUTTON
	Displays the time programmed to start.		Use this button to set the programmed time to cancel. The display shows “- ; - -”.

Note:

Please note that all the displays in the figure appear for explanation purposes or when the cover is open.

(HC0183)

7 Product Specification

7 - 2 Optional accessories

7-2-9 DST301B61: Schedule timer

OPERATION SETTING PRESENT TIME (Fig. 3)

(Example) In case of setting Friday, 5:30 p.m.

1 Press the **CLOCK ADJUSTING BUTTON**. The present time display flashes.

Note:

The present time needs adjusting in case of turning power supply on for the first time or the occurrence of power failure over the period of 48 hours or more.

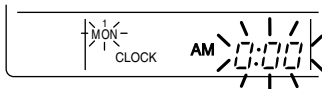

2 Press the **BUTTON FOR SELECTING DAYS OF A WEEK**. Each time the button is pressed, the day display shifts to the right.

Note:

The display "MON" follows the display "SUN".

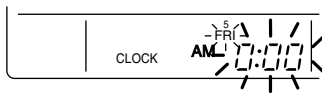

Set the day to Friday.

3 Set the time with the **HOUR/MINUTE BUTTON**. Each time the **HOUR/MINUTE BUTTON** is pressed, the display is put forward minute by minute and hour by hour. When the button is kept pressed, the display is put forward continuously.

Notes:

- After becoming "AM 11:00", when the button is pressed, the display becomes "PM 0:00".
- After becoming "59" (minute), when the button is pressed, the display becomes "00" (minute).

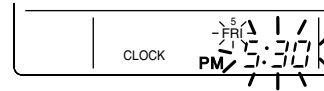

Set the time to 5:30 p.m.

4 Press the **TIMER ON BUTTON** the moment the time signal of TV, radio, telephone, etc. is heard. The mark ":" flashes, and the clock starts.

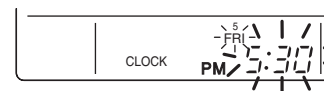

Press the **TIMER ON BUTTON** in tune with the time signal at 5:30 p.m.

Notes:

- The clock used is of 12-hour type.
- When you turn power supply on, the system may display "88" for about one minute and not start to operate after all the liquid crystal displays appear at a time.
- If the **CLOCK ADJUSTING BUTTON** is pressed by mistake, press it again to return to the original state. As the clock does not stop, the time indicated by the clock is kept correct. In case of power failure within 48 hours, the clock keeps operating by utilizing the built-in battery.

(HC0184)

7 Product Specification

7 - 2 Optional accessories

7-2-9 DST301B61: Schedule timer

SETTING NO. OF PROGRAMMED TIME (Fig. 4)

(Example)

Time No. 5 (to be programmed only when used in conjunction with the central remote control)
 Monday to Friday:
 Operating from 8:45 a.m. till 5:00 p.m.
 Operating from 5:15 p.m. till 11:00 p.m.
 Saturday and Sunday:
 Setting the whole day stop operation (application for holidays) controlled by programmed time.

1 Press the PROGRAMMING START BUTTON. Programming is available.

The display "PROGRAM" and "START" appears, and the display of days of a week flashes.

2 Press the TIME No. BUTTON, and select the desired number.

Note:
 Unless used in conjunction with the central remote control, the TIME No. is not displayed and can not be selected.
 Select the TIME No. 5.

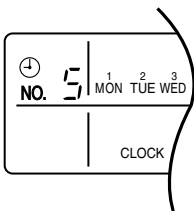

3 Press the BUTTON FOR SELECTING DAYS OF A WEEK, and set the proper day of the week. Each time you press it, the flashing display of days of a week shifts to the right.



(1) Setting programmed time

4 Set the programmed time of system start 1 by using the HOUR/MINUTE BUTTON. Each time the HOUR/MINUTE BUTTON is pressed, the display is put forward minute by

minute and hour by hour. When the button is kept pressed, the display is put forward continuously.



of system start 1 at 8:45 a.m.

5 Press the TIMER ON BUTTON, and set the programmed time of system start 1. Each time you press it, the next area to be set flashes.

Note:
 Set the other programmed time in the same procedure.



(2) Set the next day of the week.

Set the day of the week to Tuesday, and copy the program of the previous day (Monday). In the same procedure, set the day of the week to Wednesday through Friday in sequence.

6 Press the BUTTON FOR SELECTING DAYS OF A WEEK and set the following day. Press the BUTTON FOR COPYING PROGRAM OF PREVIOUS DAY. The same program as that of the immediately preceding day of the week is set.

Note:
 Repeat each procedure 3 – 5 in the above when not copying the contents of the previous day.

(3) Holiday setting

7 Press the BUTTON FOR SELECTING DAYS OF A WEEK and set one or more days of the week as holiday. Press the HOLIDAY SETTING BUTTON, and the display "OFF" is displayed at the top of the day of the week. If you press it again, the display returns to the original state.

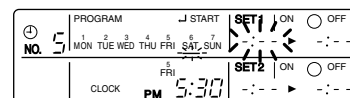

Set Saturday and Sunday as holidays.

(HC0185)

7 Product Specification

7 - 2 Optional accessories

7-2-9 DST301B61: Schedule timer

8 Press the PROGRAMMING START BUTTON, and finish the program setting.

Notes:

- Unless the button is pressed within 20 minutes, the display will automatically revert back to the original state. In this case, setting contents up to the point where the TIMER ON BUTTON (or HOLIDAY SETTING BUTTON or BUTTON FOR COPYING PROGRAM OF PREVIOUS DAY) is pressed will only take effect.
- The display "PROGRAM ↵ START" and the display of days of a week "—" disappears.
- The flashing display goes off, and the No. of programmed time of the present day is displayed. Then the operation controlled by timer starts.
- The operation controlled by timer is executed even while the program is being set.

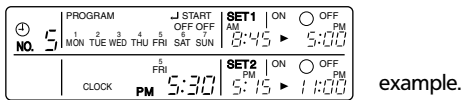

CHANGE AND CANCELLATION OF NO. OF PROGRAMMED TIME (Fig. 5)

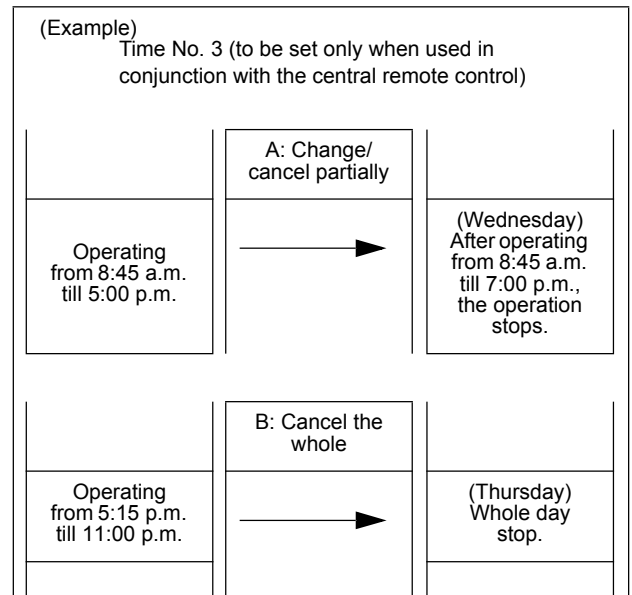

1 Press the PROGRAMMING START BUTTON. The program setting is ready. The display "PROGRAM ↵ START" appears, and the display of days of a week flashes.

2 Press the TIME No. BUTTON, and select the desired No.

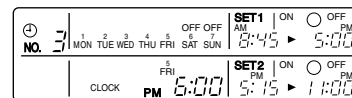

Select the time No. 3.

3 Press the BUTTON FOR SELECTING DAYS OF A WEEK, and set the day of the week to be changed. The set No. of programmed time of the day of the week is displayed.

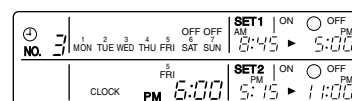

Set the day to Wednesday.

7 Product Specification

7 - 2 Optional accessories

7-2-9 DST301B61: Schedule timer

A. Change/cancel partially

4 Press OK button if you do not want to change the timer on. The display of the next programmed time flashes. Each time you press it, the next area to be set flashes.



Shift to the display "PROGRAMMED TIME OF SYSTEM OFF".

5 Press the HOUR/MINUTE BUTTON and change the programmed time. Press the OK BUTTON, and finalize the setting of change.

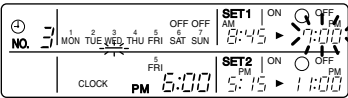

Change the programmed time of system OFF p 1 to 7:00 p.m.

6 Press the PROGRAM CANCELING BUTTON, and cancel the programmed time. If you press it again, display returns to the original state. Press the TIMER ON BUTTON to finalize the cancellation.

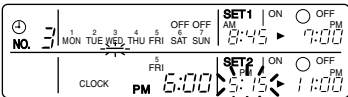

Shift to the programmed time of system start 2.

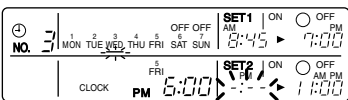

Set the programmed time of system start 2 to program cancellation.

In the same procedure, cancel the programmed time of system off 2.

B. Cancel the whole

7 Press the BUTTON FOR SELECTING DAYS OF A WEEK, and shift to the day of the week to be canceled. Then, press the HOLIDAY SETTING BUTTON; the display "OFF" appears at the top of the particular day of the week. The programmed time is canceled. If you press the button again, the display returns to the original state.



Shift the day of the week to Thursday to set as a holiday.

8 Press the PROGRAMMING START BUTTON. The program setting is now finished.

- Unless the button is pressed within 20 minutes, the display will automatically revert back to the original state. In this case, setting contents to the point where the TIMER ON BUTTON (or HOLIDAY SETTING BUTTON or BUTTON FOR COPYING PROGRAM OF PREVIOUS DAY) is pressed will only take effect.
- To continue the change/cancellation, do not press the PROGRAMMING START BUTTON until all change/cancellation are completed.
- The operation controlled by timer is executed even while the program is being set.

(HC0186)

7 Product Specification

7 - 2 Optional accessories

7-2-9 DST301B61: Schedule timer

MANUAL OPERATION (Fig. 6)

This schedule timer enables the operation/stop by pressing the UNIFIED OPERATION/STOP BUTTON in addition to the operation controlled by timer (operation/stop according to the programmed time) at any time.



Press the UNIFIED OPERATION BUTTON, and the OPERATION LAMP turns on.



Press the UNIFIED STOP BUTTON, and the OPERATION LAMP is turned off.

- The operation automatically stops according to the programmed time of system off even during the manual operation. In the meantime, the operation starts automatically according to the programmed time of system start even during the stop of operation.
- If the unit is used in conjunction with other optional controllers for centralized control, the OPERATION LAMP of the unit that is not under operation control may be turned on or off a few minutes behind schedule. This shows that the signal is being exchanged, and does not indicate any failure.

(HC0187)

Operation lamp
○ Turn on: The light turns on when any of the indoor units is in operation whether the operation is controlled by timer or by hand.
● Turn off: The light turns off when all the indoor units stop.

OPERATION CONTROL CODE

Two different types of operation control codes can be selected when this kit is used independently (when not used in conjunction with the central remote control, unified ON/OFF controller, etc.).

■ Individual

In case where the operation/stop is controlled by both schedule timer and remote control.

(HC0188)

■ Centralized

The operation is controlled by the schedule timer alone, and the operation/stop is controlled freely with the remote control during the programmed time.

- For current settings, contact your DAIKIN dealer.
- To change settings, contact your DAIKIN dealer.
Do not change settings yourself.

ERROR DIAGNOSING FUNCTION (Fig. 7)

This schedule timer is provided with the malfunction diagnosing function. The malfunction code flashes if there occurs any malfunction in communication, etc. between and among the optional controllers for centralized control. In addition, the operation lamp also flashes if there occurs any malfunction in communication with the indoor unit. Check the contents of the display and contact your DAIKIN dealer because the signals give you the idea of the trouble area.

Operation lamp	Malfunction code	Contents of malfunction
Turn off	M1	Failure of PC board of schedule timer.
Turn on or off	M8	Malfunction of transmission between each optional controller for centralized control.
Turn on or off	MA	Improper combination of optional controllers for centralized control.
Turn on or off	MC	Address failure of schedule timer.
Flash	UE	Malfunction of transmission between indoor unit and optional controllers for centralized control.
Flash	-	Malfunction in indoor unit (Refer to the malfunction codes of the indoor remote control, while also read the "CAUTION FOR SERVICING" attached to the indoor unit.)

7 Product Specification

7 - 2 Optional accessories

7-2-9 DST301B61: Schedule timer

SPECIFICATION

■ SPECIFICATIONS

Display of time	12-hour digital display
Clock cycle type	Quartz clock type
Clock accuracy	Within ± 30 sec. / month (environmental temperature from 15°C to 35°C)
Timer programming	Two pairs of programmed time for both system start and system off can be set in units of minute for each day of the week
Power failure compensation time	Approximately 48 hours for a single occurrence of power failure (clock with No. of programmed time)
Size (Width \times Height \times Depth)	120(W) \times 120(H) \times 53(D) mm
Weight	Approximately 210g

■ OUTLINE DRAWINGS

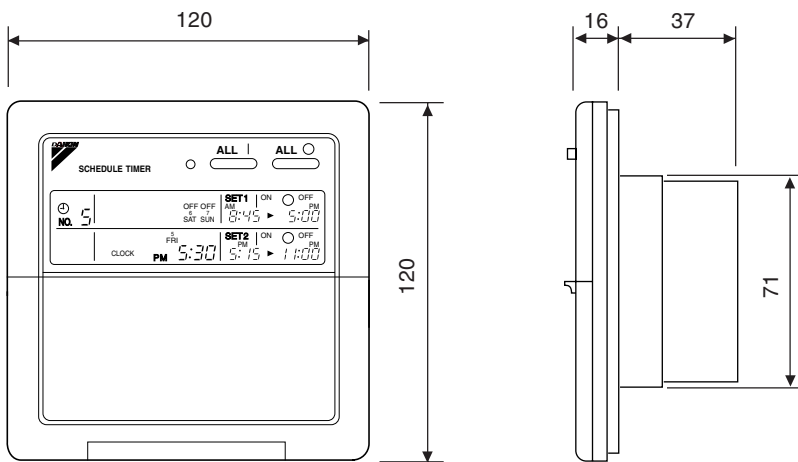

Specifications and appearance subject to change without notice.

(HC0189)

7 Product Specification

7 - 2 Optional accessories

7-2-10 K-DGL100A, K-DGL150A, K-DGL200A, K-DGL250A: Air suction / discharge grille

Model name	K-DGL100A	K-DGL150A	K-DGL200A	K-DGL250A
Applicable model	VAM150FA	VAM250FA VAM350FA	VAM500FA VAM650FA	VAM 800FA VAM1000FA VAM1500FA VAM2000FA
Nominal pipe diameter (mm)	φ 100	φ 150	φ 200	φ 250
Noise reducing effect (dB)	approx. 6	approx. 6	approx. 11	approx. 11
Effective opening area (cm ²)	187	257	333	438
Weight (kg)	2.4	3.3	4.5	5.2

Applications and features

- The grille can be installed at any location, using a duct.
- The grille effectively reduces the total heat exchanger noise transmitted from the duct.

Cautions

- ² Do not install the grille in a place of excessive high temperature.
- ² Do not install the grille in a place of much oil and smoke and of high humidity.

Pressure loss curve

K-DGL100A

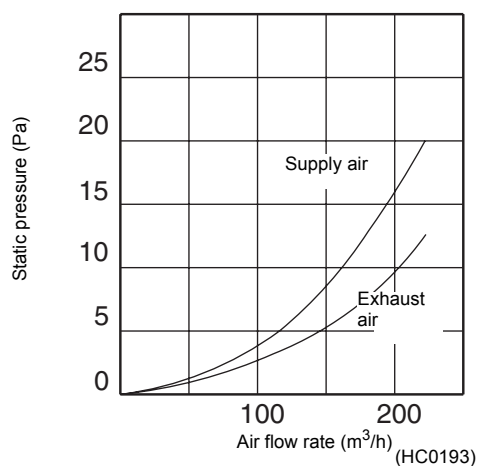

K-DGL150A

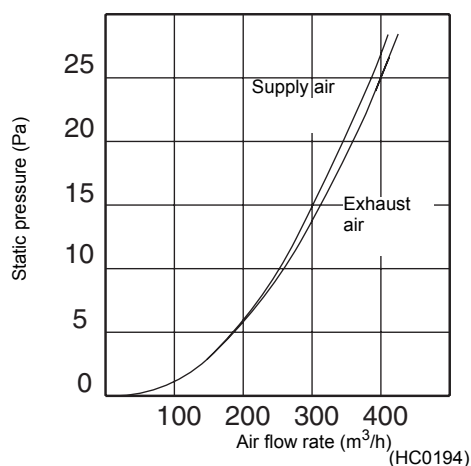

K-DGL200A

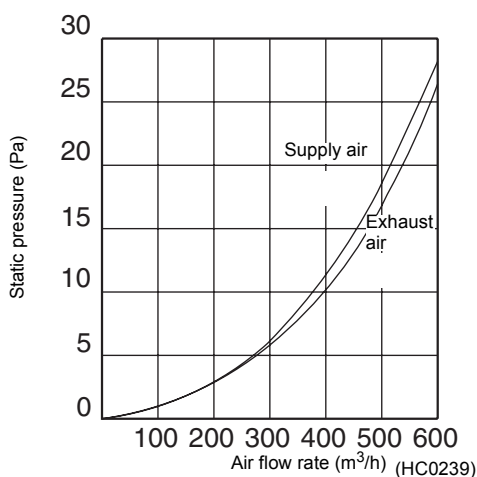

K-DGL250A

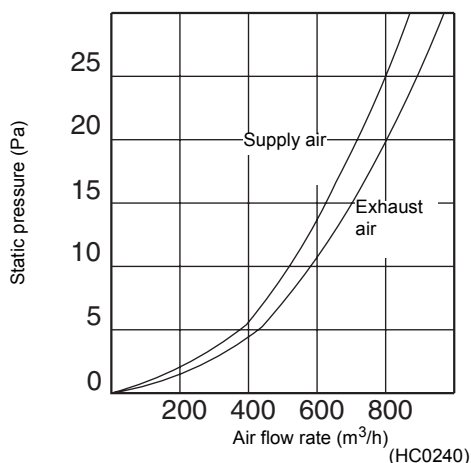

7 Product Specification

7 - 2 Optional accessories

7-2-10 K-DGL100A, K-DGL150A, K-DGL200A, K-DGL250A: Air suction / discharge grill

Dimensions

K-DGL100A

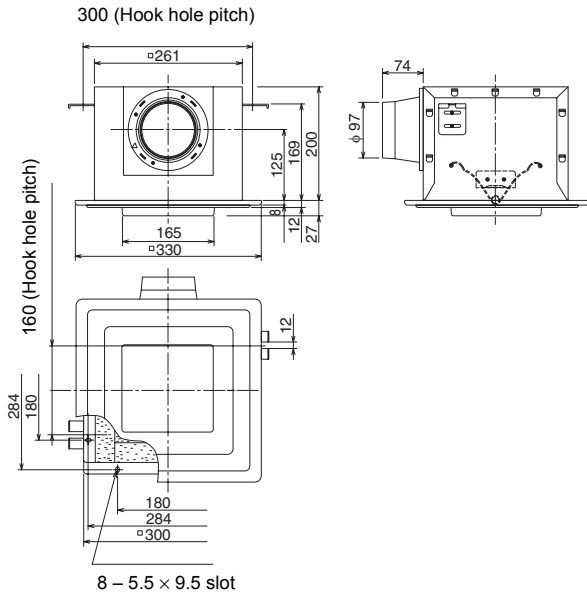

K-DGL150A

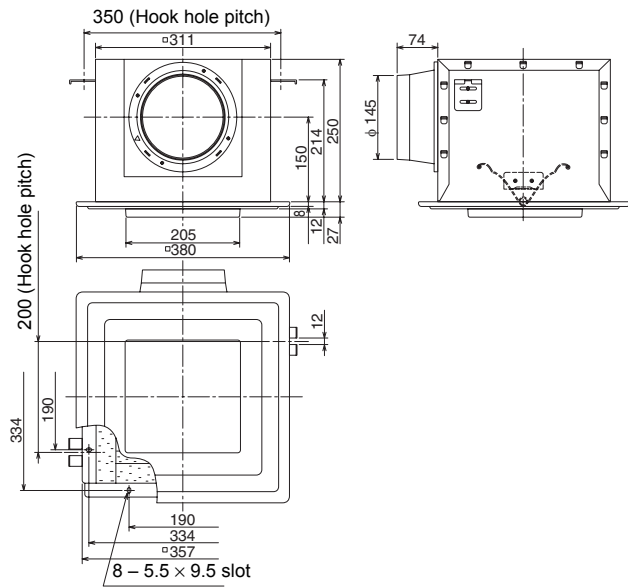

(HC0242)

K-DGL200A

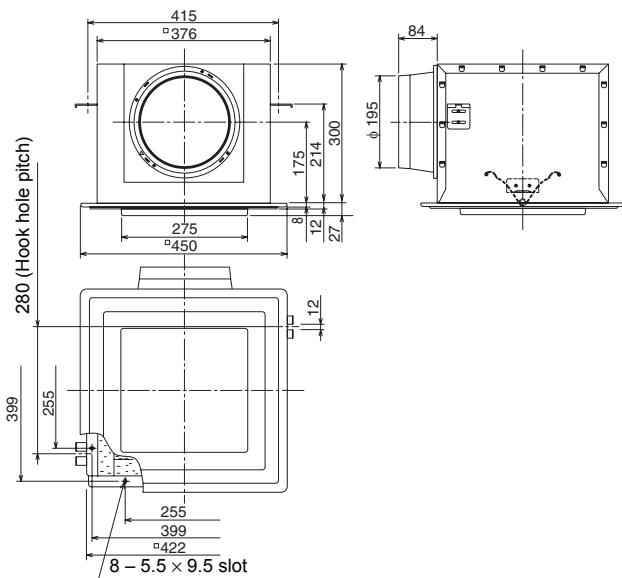

(HC0243)

K-DGL250A

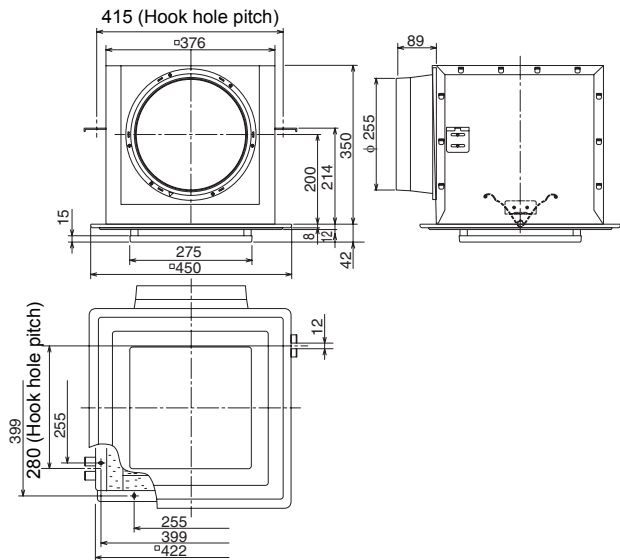

(HC0244)

7 Product Specification

7 - 2 Optional accessories

7-2-10 K-DGL100A, K-DGL150A, K-DGL200A, K-DGL250A: Air suction / discharge grill

Installation procedure

Before starting installation, attach the supplied packing to the adapter provided in the same package.
(Attach the packing to the adapter flange so that it will be set within the periphery of the flange.)

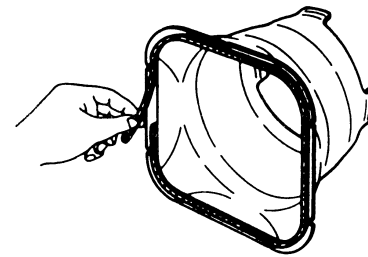

(HC0198)

For installing on a wooden frame (Using ceiling joist)

1. Fabricate the wooden frame and attach it to the ceiling joist.
 - * If the joist is not strong enough to support the unit, use hanging bolts as well.

	K-DGL100A	K-DGL150A	K-DGL200A K-DGL250A
Inner dimension	□ 270	□ 320	□ 385
Wooden frame	Approx. 30 mm (square)		

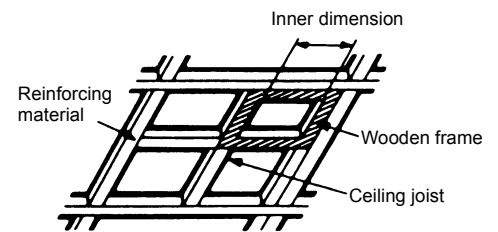

(HC0199)

2. Put the unit inside the wooden frame and fix the unit using the provided tapping screws (long ones).
3. Attach the adapter to the body using the provided tapping screws (short ones).

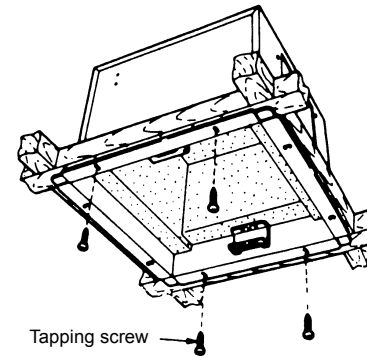

(HC0200)

For suspending on anchor bolts

1. Attach the adapter to the body using the provided tapping screws (short ones).

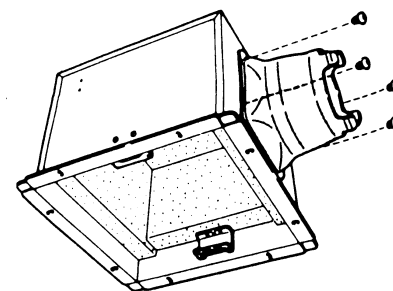

(HC0201)

2. Fix the provided hook metals (2 pcs.) to the body using the four tapping screws (short ones).
3. Fix the body to the anchor bolts so that it stays horizontally level. (M8 or M10)

Hook metal fixing position

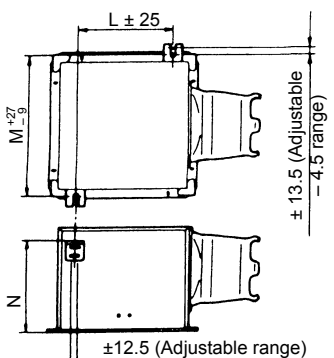

Dimension table Unit: mm

Part No.	L	M	N
K-DGL100A	160	300	169
K-DGL150A	200	350	214
K-DGL200A	280	415	214
K-DGL250A	280	415	214

(HC0197)

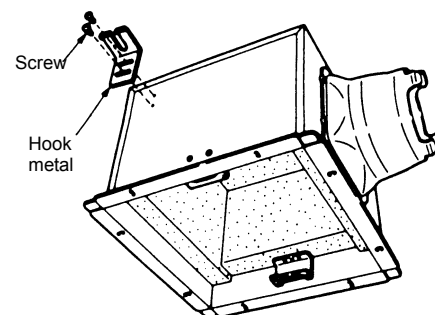

(HC0202)

7 Product Specification

7 - 2 Optional accessories

7-2-10 K-DGL100A, K-DGL150A, K-DGL200A, K-DGL250A: Air suction / discharge grill

Common works

Duct connection and ceiling board installation

- Put the duct into the adapter and fix them by winding tape around the joint.
(Suspend the duct from the ceiling to prevent any load from being applied to the body.)

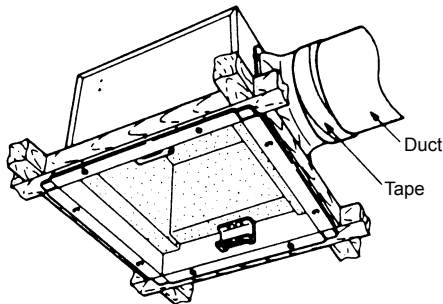

(HC0203)

- Install the ceiling board, providing a clearance of 2 to 5 mm between the flange and the board.
(If no clearance is provided, maintenance of the unit cannot be performed.)

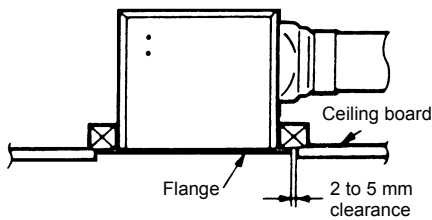

(HC0204)

Installation of the panel

Contract the panel spring and put it in the panel holder slot to fix the panel.

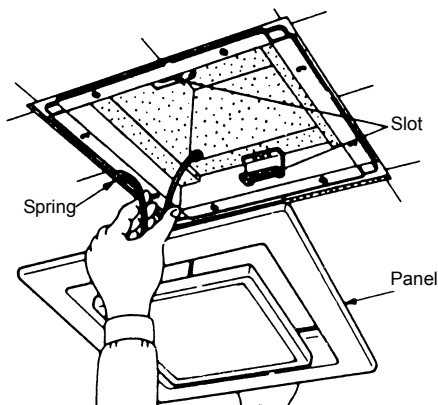

(HC0205)

Installing the ceiling material and gluing the wall paper

For installing the ceiling material

- Cut the ceiling material to the following dimensions.

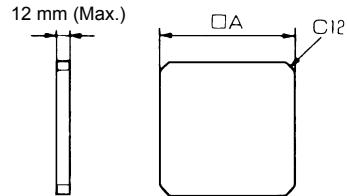

(HC0206)

	K-DGL100A	K-DGL150A	K-DGL200A, 250A
A	157	197	267

- Avoid using heavy (0.7 kg or more) or fragile material as the ceiling material.
- Remove the four screws and detach the panel.

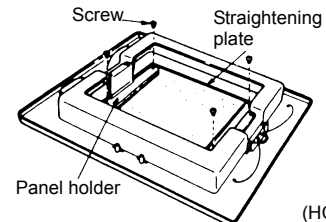

(HC0207)

- Cut the panel along the groove.

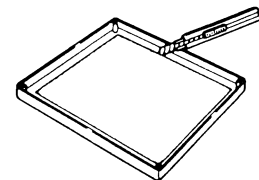

(HC0208)

- Put the cut ceiling material and reassemble the panel.
(If the ceiling material thickness is not more than 12 mm, attach the provided packing to the rear side of the panel holder.)

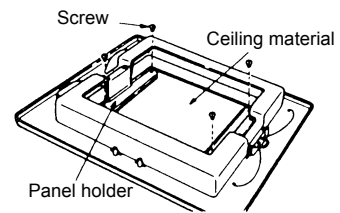

(HC0209)

For gluing the wall paper

- Prepare a piece of plywood of the same size as the ceiling material.
- Glue the wall paper to the plywood.
(The thickness after gluing the wall paper should not be more than 12 mm.)

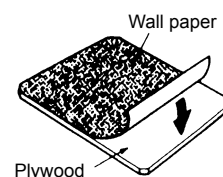

(HC0210)

C: 3K074171-1A

7 Product Specification

7 - 2 Optional accessories

7-2-11 KDDM24A50, KDDM24A100: Silencer

Part No.	KDDM24A50	KDDM24A100	
Applicable model	VAM500FA	VAM650FA	VAM800FA, VAM1000FA, VAM1500FA, VAM2000FA
Nominal pipe diameter	φ 200 mm	φ 200 mm	φ 250 mm
Noise suppression effect	Approx. 6 dB		

Applications and features

- The silencer effectively reduces the noise of the HRV units.
- Air flow rate should be lower than 600 m³ / h for the model KDDM24A50 and lower than 1000 m³ / h for the model KDDM24A100.

Caution

The silencer cannot be used on different model. Confirm the model before installation.

Dimensions

KDDM24A50

KDDM24A100

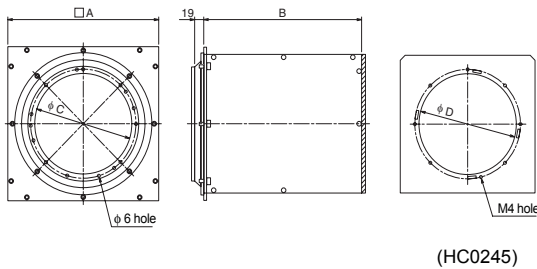

Dimension table (unit: mm)

Part name	A	B	C	D
KDDM24A50	320	340	206	210
KDDM24A100	380	480	250	260

Installation procedure

1. Remove the flange from the silencer.

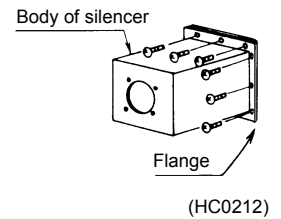

2. Remove the duct coupling of the air inlet provided on the body of HRV units.

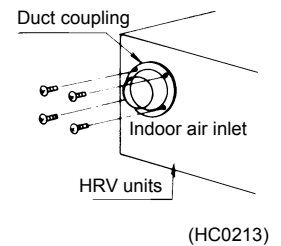

3. Use the provided screws and install the flange on the HRV units.

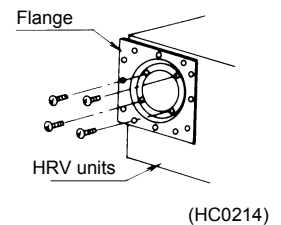

4. Install the silencer on the flange. Then, install the duct coupling.

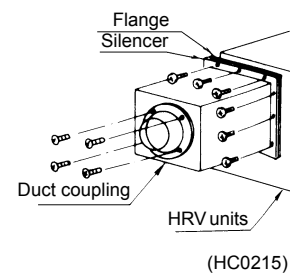

5. Insert the duct into the duct coupling and wind round the commercially available aluminum tape, etc. to prevent the air leakage.

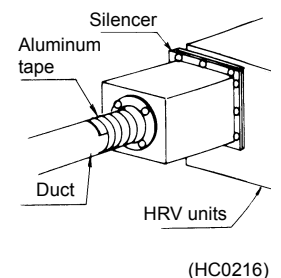

7 Product Specification

7 - 2 Optional accessories

7-2-12 YAFF323F15, YAFF323F25, YAFF323F35, YAFF323F50, YAFF323F65, YAFF323F100:
Air filter replacement

Part No.	Applicable model	Q'ty
YAFF323F15	VAM150FA	2
YAFF323F25	VAM250FA	2
YAFF323F35	VAM350FA	2
YAFF323F50	VAM500FA	2
YAFF323F65	VAM650FA, VAM800FA	2
	VAM1500FA	4
YAFF323F100	VAM1000FA	2
	VAM2000FA	4

Specification

Working ambient temperature	- 10 °C to 50 °C
Working ambient humidity	Less than 85% RH
Pressure loss	Initialloss: Less than 1.5 mm H ₂ O Finalloss: 8 mmHzO
Life	Over 2500 hours (Dust density: 0.10 mg / m ³ h)
Average dust collecting efficiency	Over 82% (Gravimetric method)

Dimension

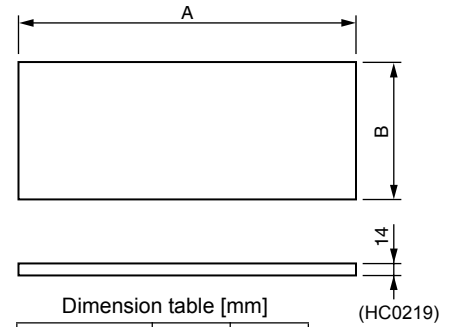

Dimension table [mm]

Part No.	A	B
YAFF323F15	362	147
YAFF323F25	435	147
YAFF323F35	621	167
YAFF323F50	725	167
YAFF323F65	757	202
YAFF323F100	1016	202

7 Product Specification

7 - 2 Optional accessories

7-2-13 K-FDS101C, K-FDS151C, K-FDS201C, K-FDS251C, K-FDS102C, K-FDS152C, K-FDS202C, K-FDS252C: Flexible Duct

Part Name: 1 m	K-FDS101C	K-FDS151C	K-FDS201C	K-FDS251C
Part Name: 2 m	K-FDS102C	K-FDS152C	K-FDS202C	K-FDS252C
Applicable model	VAM150FA	VAM250FA VAM350FA	VAM500FA VAM650FA	VAM 800FA VAM1000FA VAM1500FA VAM2000FA
Nominal diameter	φ 100	φ 150	φ 200	φ 250
Duct length	1 m (101C, 151C, 201C, 251C)			
	2 m (102C, 152C, 202C, 252C)			

Applications and features

- Flexible duct is used for the outdoor supply air / exhaust air.
- The flexible duct can be bent according to the place of installation and is suitable for installation involving a height difference between the body and the supply air / exhaust air opening. The flexible duct helps simplify installation and construction.
- The flexible duct can be extended by using provided joints.

Cautions

- Do not use the flexible duct in a place of mush oil and smoke or high humidity such as bathroom and kitchen.
- Broken flexible duct and surface sheet cause air leakage. Pay particular attention to them.
- Maintain the wind speed at 15 m / sec. inside the flexible duct. Working static pressure must be within -13 mmH₂O to 50 mmH₂O.

Installation procedure

- Use the nominal diameter of the connecting pipe according to the noise suppression duct diameter.
 - Use the provided clamp band to secure the noise suppression duct. Insert the connection opening of the noise suppression duct into the connecting pipe and tighten with clamp band.
1. Insert the connection opening of the noise suppression duct into the connecting pipe.

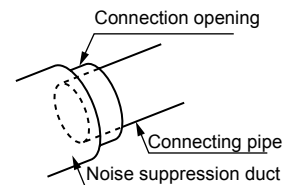

(HC0221)

2. Install the clamp band on the connection opening of the noise suppression duct. Use a screwdriver to turn the clamp screw to securely clamp the duct.

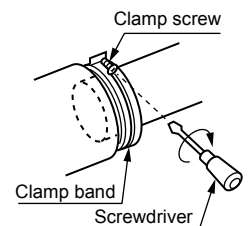

(HC0222)

7-2-14 YDFA25A1: Duct adapter

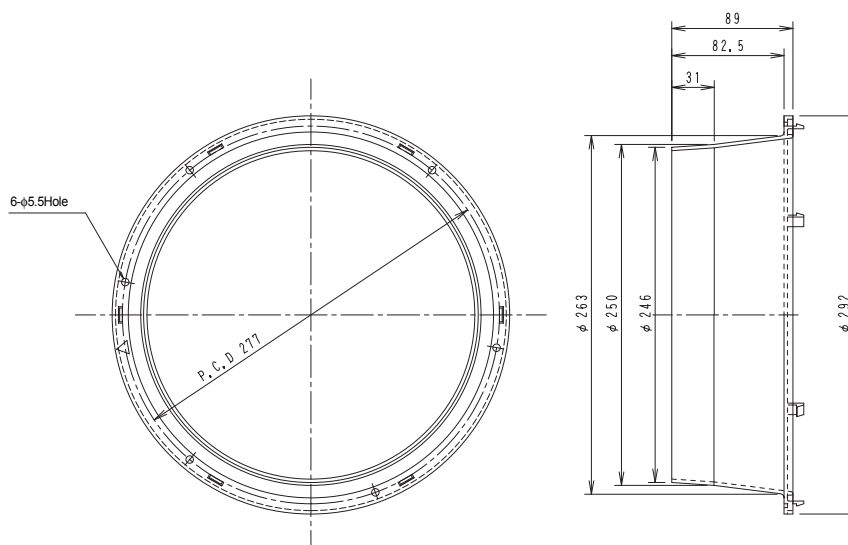

Material: Polystyrene (Flammability: UL94V - O)

3D013345

7 Product Specification

7 - 2 Optional accessories

7-2-15 BRP4A50: Heater control kit

Operation range of the HRV is “ -10°C to 50°CDB 80% RH or below.”

When operating the HRV units at or below -10°C of the outdoor air temperature, use preheater (field supplied) to preheat outdoor air. This kit is required to have ON / OFF delay control when preheater is used. (Initial setting is required.)

Cautions

- For electric heater, safety devices and installation location, follow the standards or regulations of each country.
- Use nonflammable duct for the electric heater. Be sure to keep 2 m or more between the heater and HRV unit for safety.
- For the HRV units, use a different power supply from that of the electric heater and install a circuit breaker for each.

Electric heater capacity formula

$$\text{Heat capacity } P \text{ (kW)} = 0.29 \times \text{Air flow rate} \times \text{Temp.} / 860$$

For VAM500FJVE when Air flow rate = 500m³ / h (Ultra-high) and preheater so that the outdoor temp. rise from -20°C to -10°C (Temp. = 10 °C)

$$P = (0.29 \times 500 \times 10) / 860 = 1.68 \text{ (kW)}$$

Check the temperature rise at low notch.

For 2kW heater, when 300m³ / h

$$T = (860 \times P) / (0.29 \times \text{Air flow rate})$$

$$= (860 \times 2) / (0.29 \times 300) = 19.7 \text{ }^\circ\text{C}$$

Therefore - 20 + 19.7 = -0.3°C

Cautions at initial setting

- Make sure to set remote control of HRV at initial setting as follows:
(for ON / OFF delay)

	Setting mode	Setting switch no.	Setting position
Heat setting	19	8	03 or 04

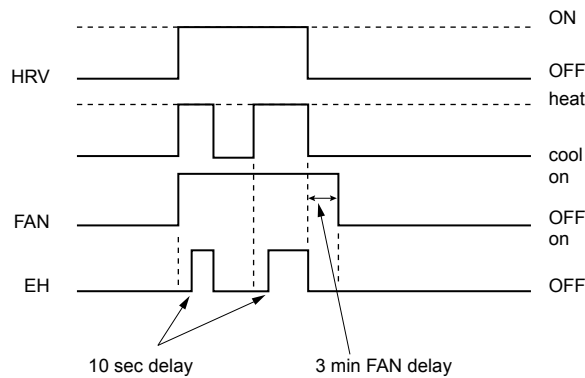

(HC0097)

- Heater operating condition
Heater starts operation when it is judged as Heating operation.
(Judged from VRV signal of heating operation or HRV signal of thermostat.)
- ON / OFF delay
Heater starts 10 seconds after HRV starts operation.
Fan stops 3 minutes later after HRV stops operation.

7 Product Specification

7 - 2 Optional accessories

7-2-15 BRP4A50: Heater control kit

Installation example

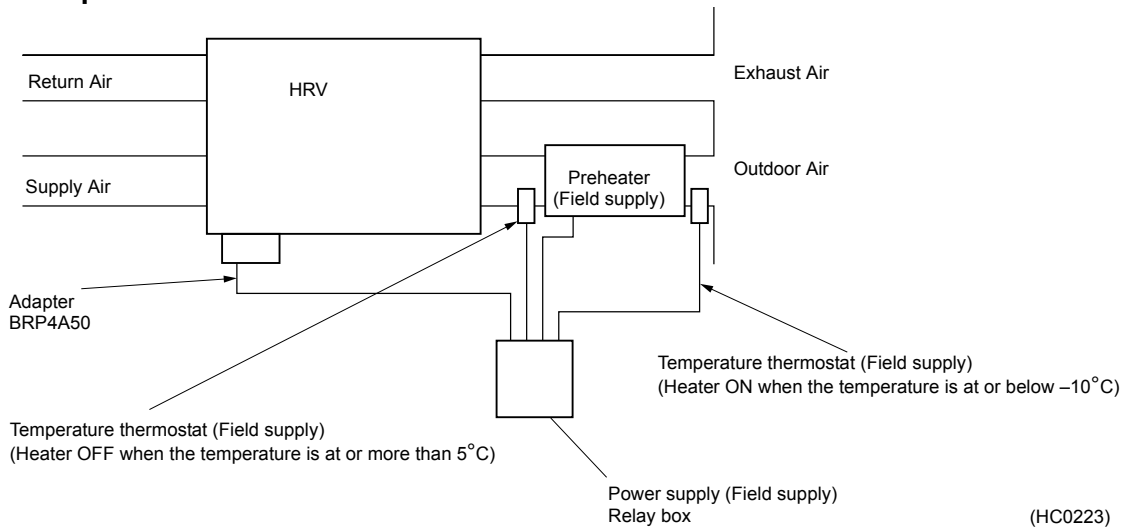

(HC0223)

Wiring

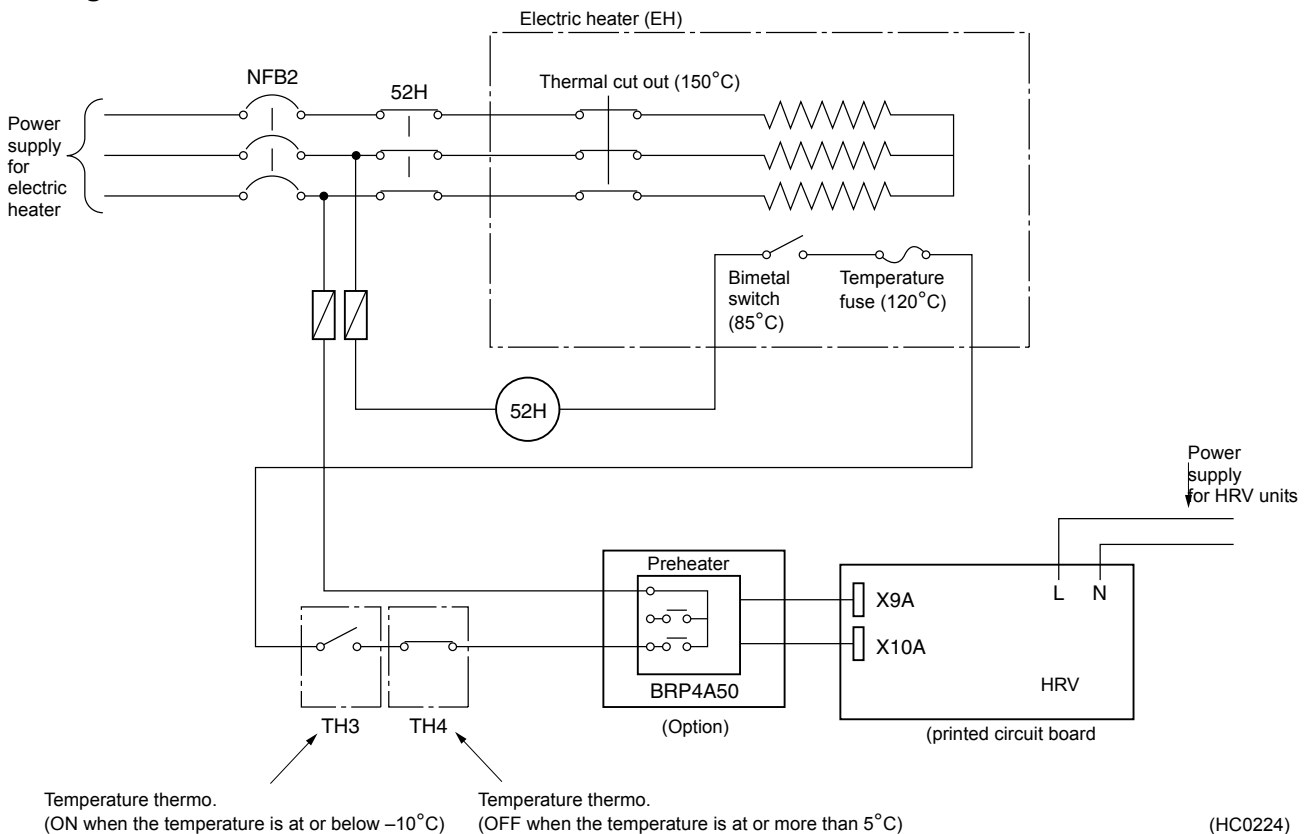

(HC0224)

Symbol	Part	Installation Place	Field supply
52H	Relay	Install a relay box at site	Field supply
EH	Electric heater (Bimetal switch, Temperature fuse, Thermal cut out etc. (built in))	Duct	Field supply
TH3	Temperature thermostat (ON when the temperature is at or below -10°C)	Duct (front of EH)	Field supply
TH4	Temperature thermostat (OFF when the temperature is at or more than 5°C)	Duct (behind EH)	Field supply

Note:

Make sure to install TH3 and TH4 for safety.

Test run

After completing the installation of the system, check again to make sure that no error was made in wiring or switch setting on the printed circuit boards of the HRV units. Then, turn on the power of the HRV units. Refer to the manual of the remote control of each unit (remote control for air conditioner, central control unit, etc.) for conducting a trial operation.

7 Product Specification

7 - 2 Optional accessories

7-2-15 BRP4A50: Heater control kit

Heater control kit

Accessories

See the right for component.

Fixing Screw	2 pcs.
Clamp	2 pcs.

Installation

Install the Heater control kit to the outside of switch box for HRV unit as shown below.

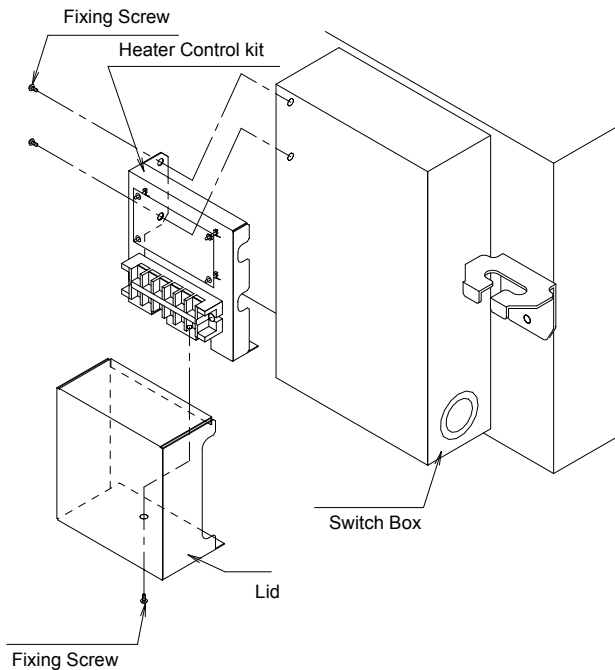

<< Cautions >>

< Switch setting of the HRV unit >

The initial setting is required by remote control for indoor unit or HRV unit.

See the INSTALLATION MANUAL of HRV (Local setting) Electric heater setting ON, OFF delay [19 (29 • 8 • 03]

※ The initial setting is necessary for safety.

3P055038

Switch box

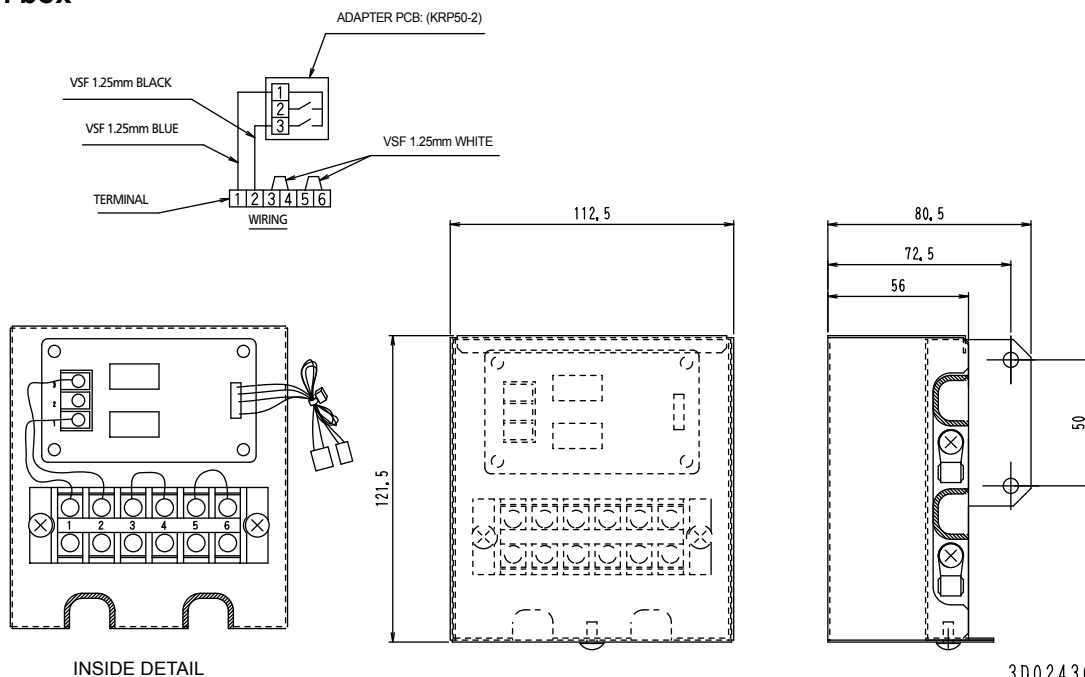

3D024303

7 Product Specification

7 - 3 The correction ratio of exchange efficiency

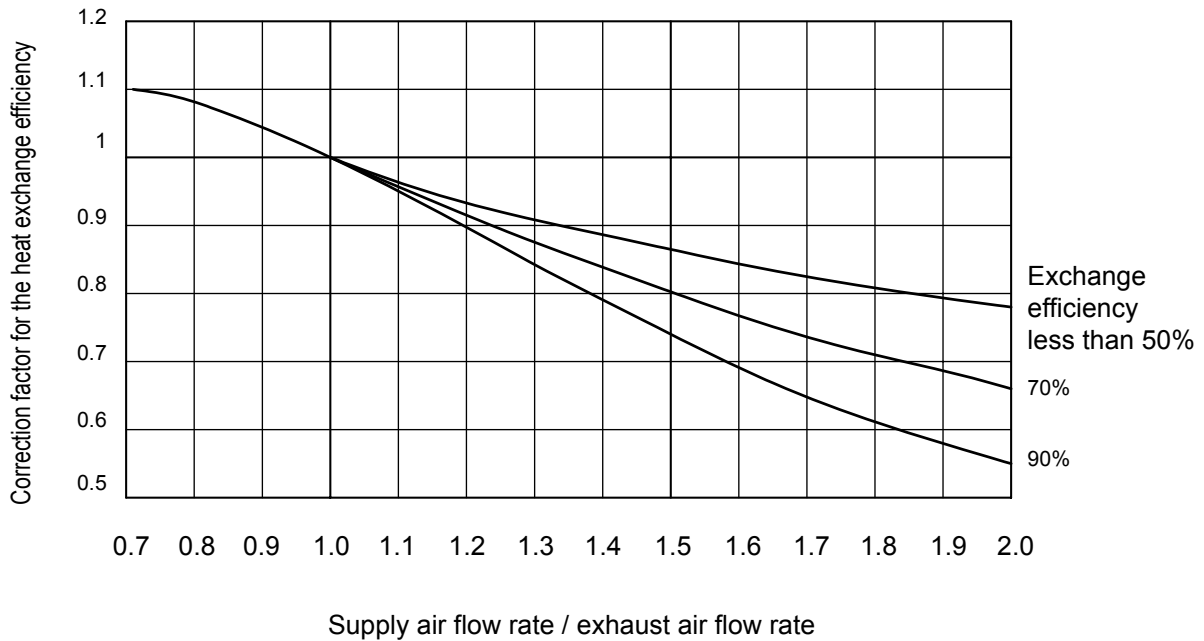

4D023764

<Example of correction>

VAM500 (50Hz): Air flow rate at strong notch 500 m³/h
 (Cooling) Enthalpy exchanging efficiency 58%

Supply air and exhaust air flow rate for fresh-up mode:
 Supply air flow rate / Exhaust air flow rate = 550 / 500 = 1.1
 (Cooling) Enthalpy exchange efficiency from above table
 $58 \times 0.96 = 55.6\%$
 ↑ Correction ratio

7 Product Specification

7 - 4 Dimensions

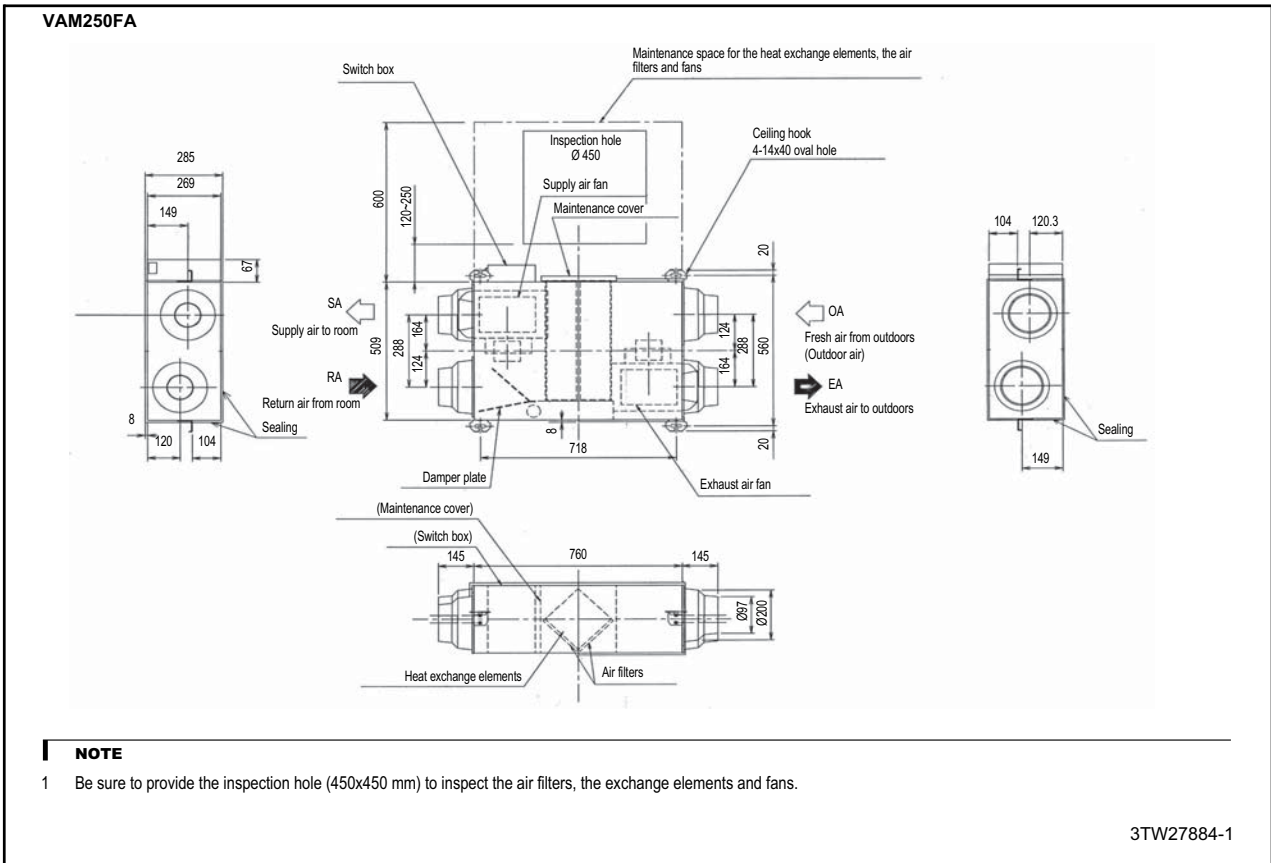
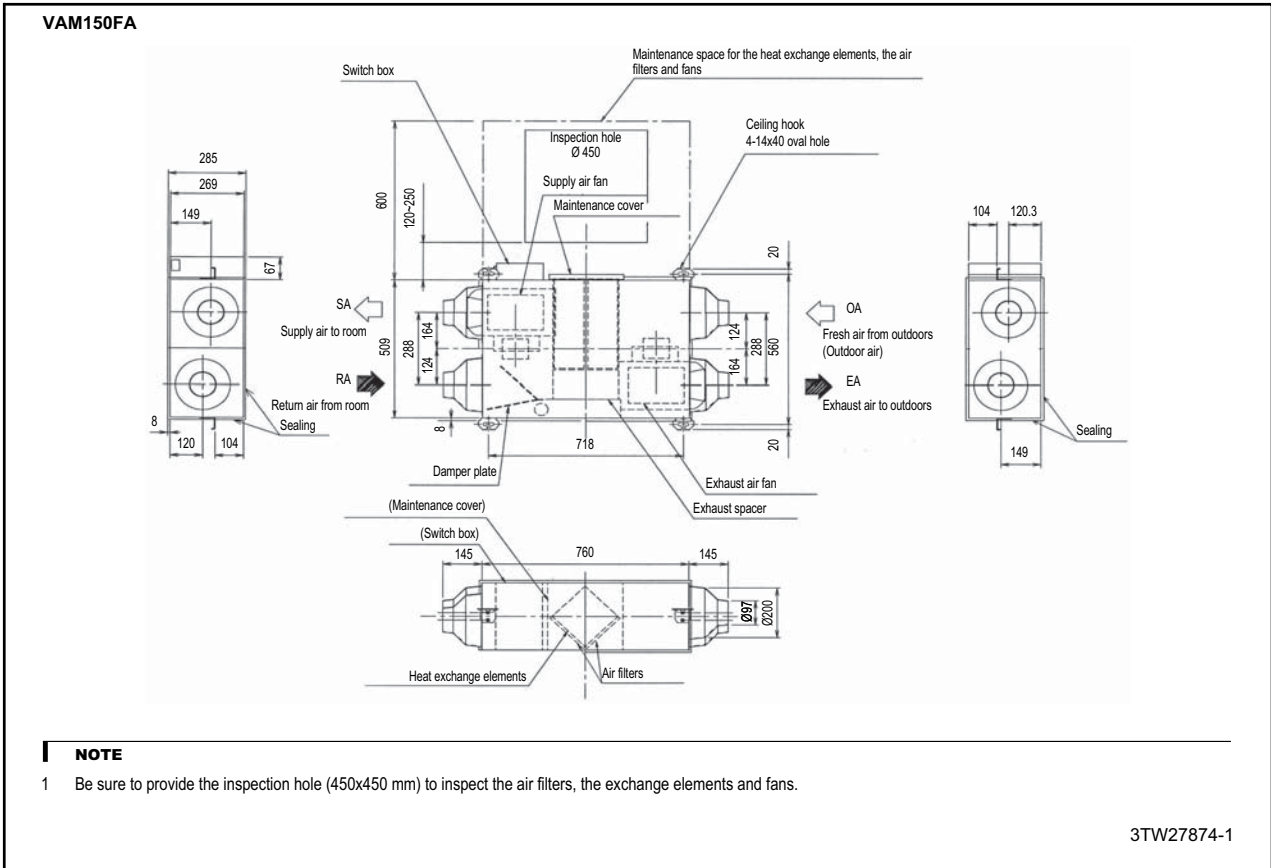

7 Product Specification

7 - 4 Dimensions

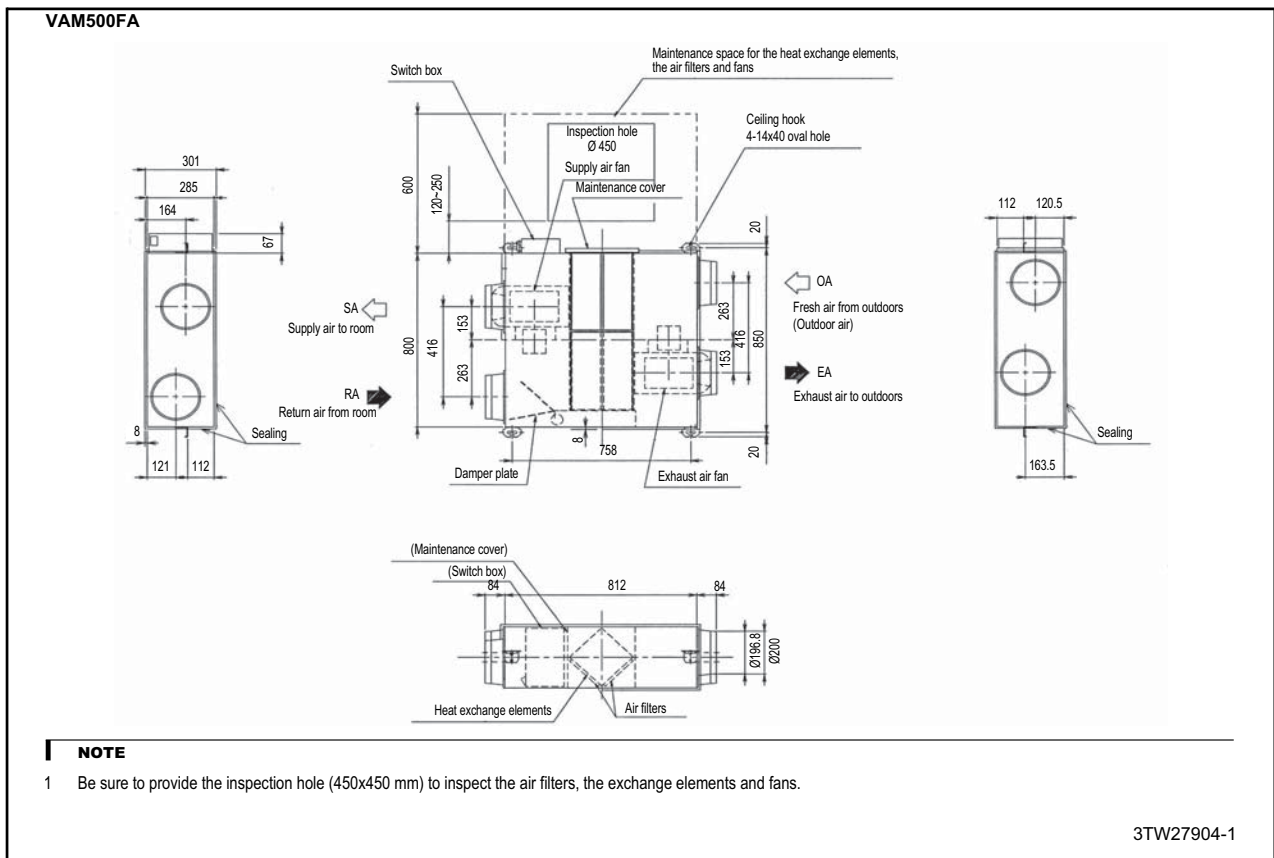
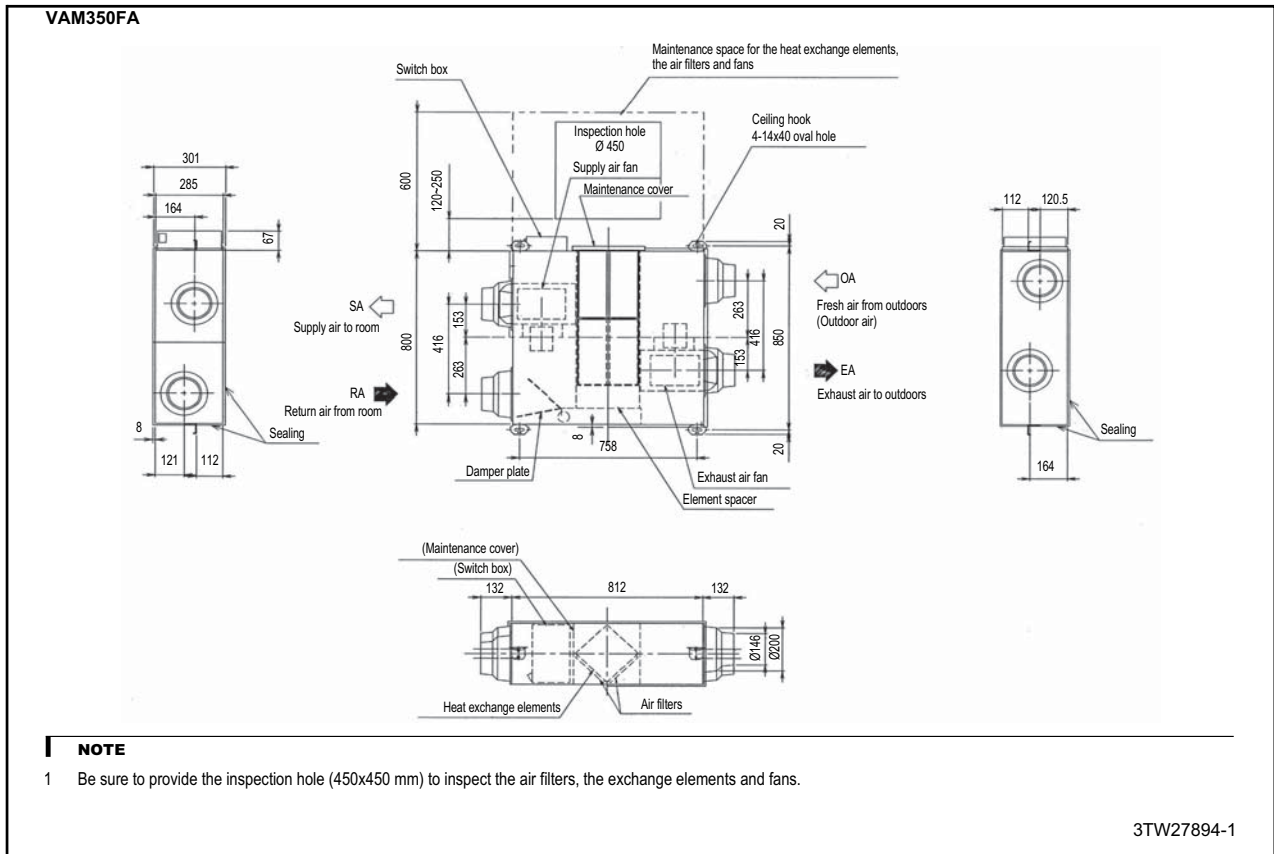

7 Product Specification

7 - 4 Dimensions

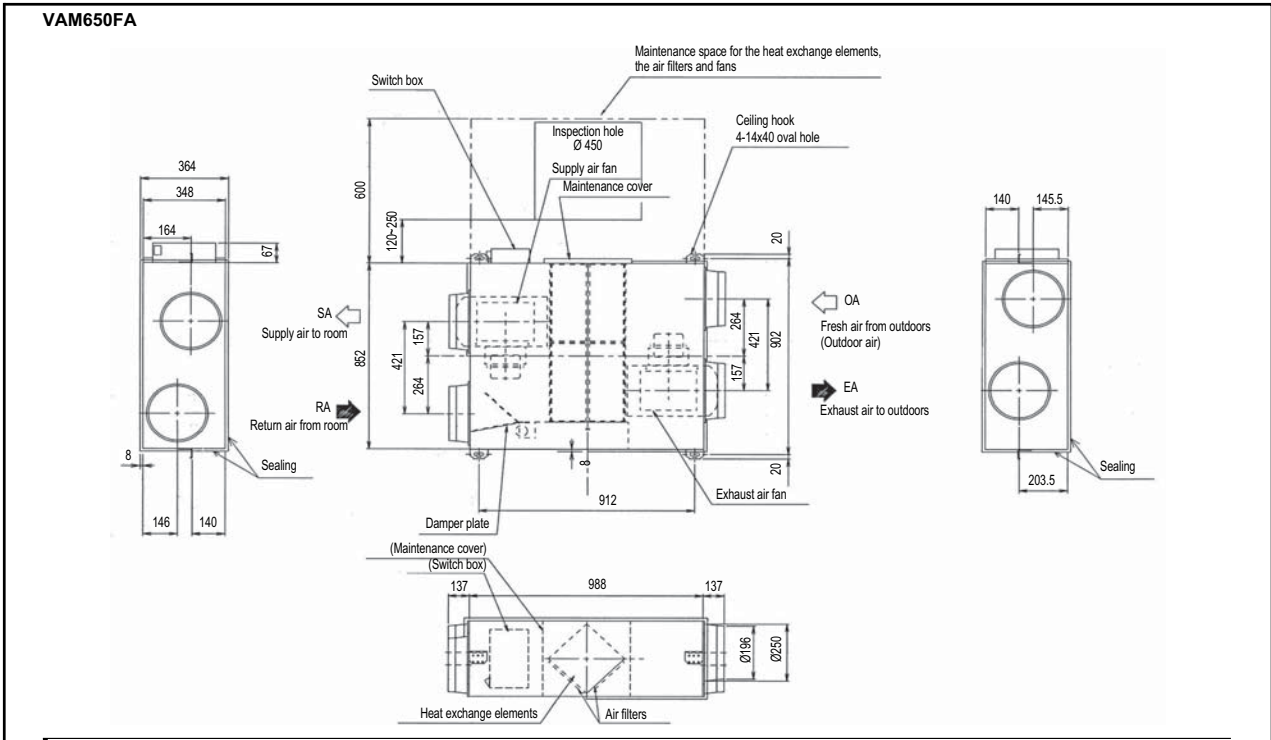

3TW27914-1

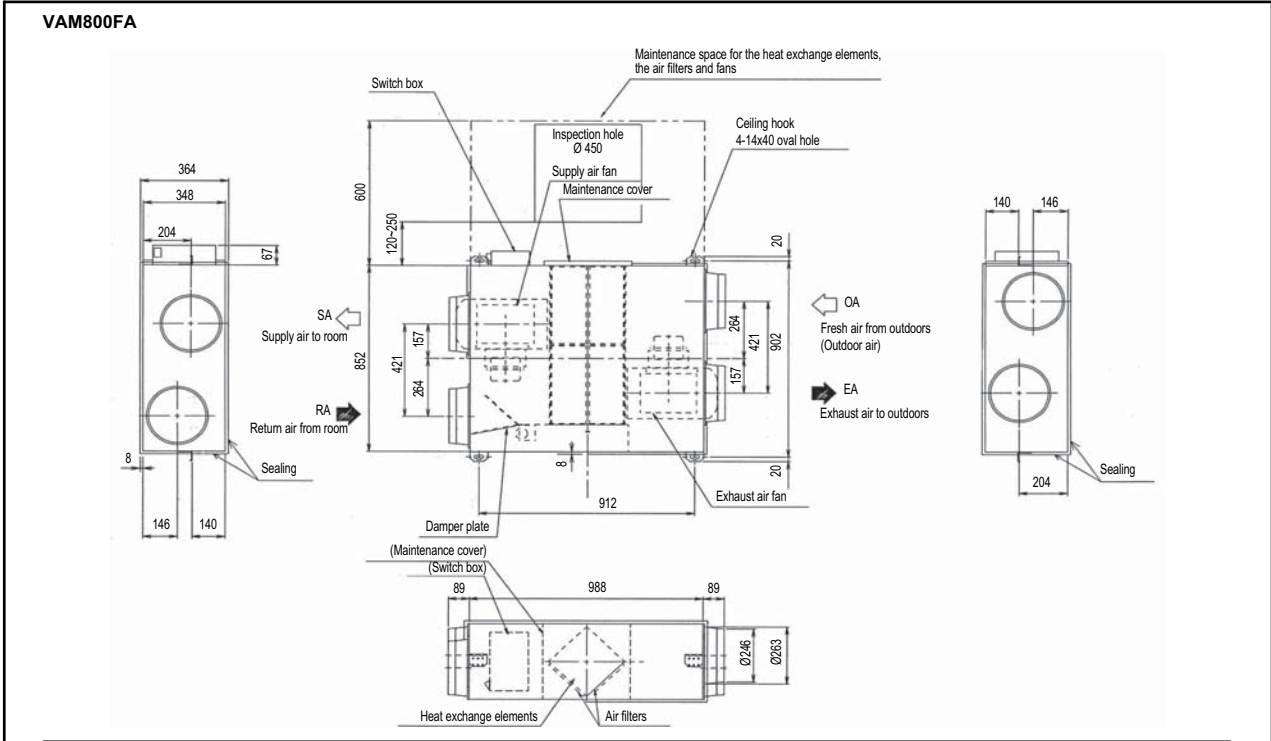

3TW27924-1

7 Product Specification

7 - 4 Dimensions

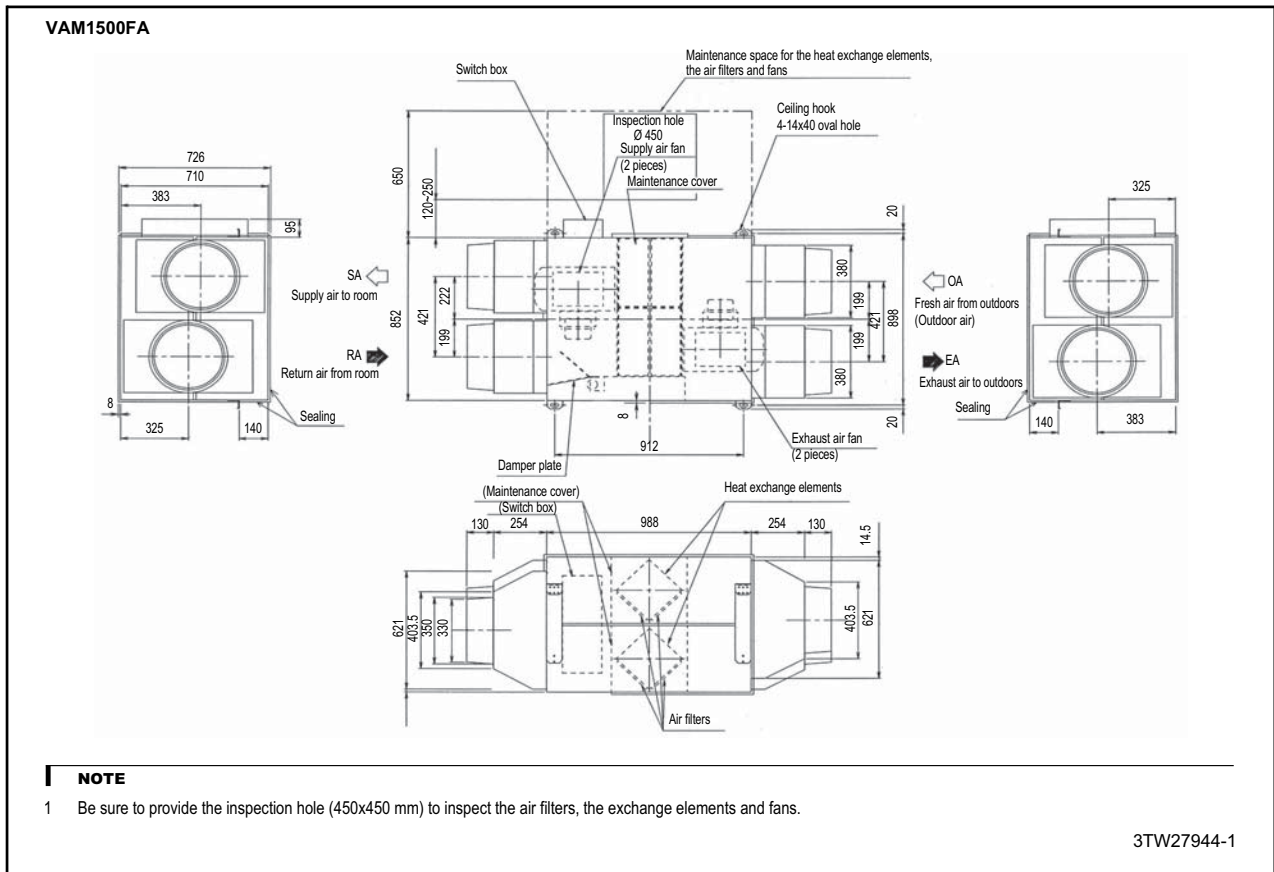
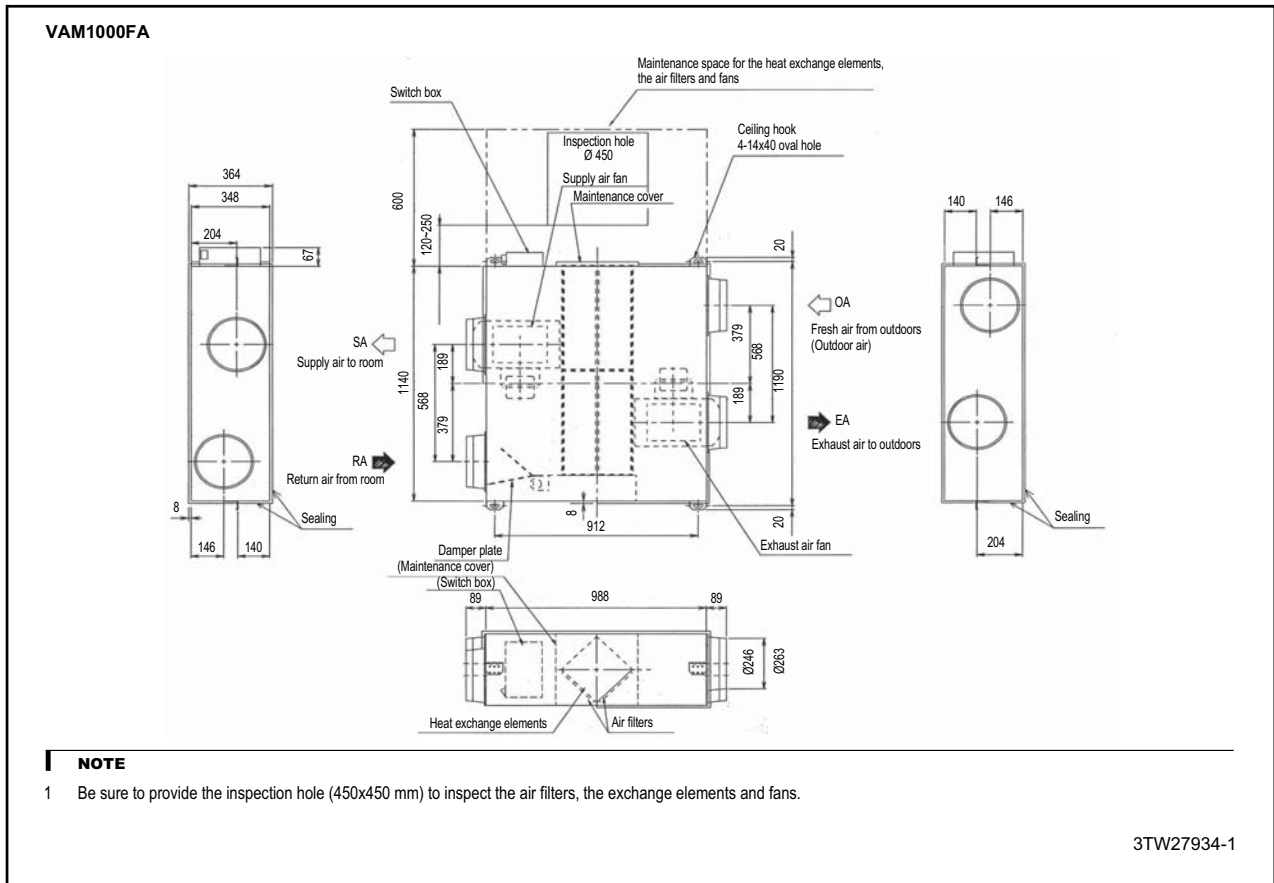

7 Product Specification

7 - 4 Dimensions

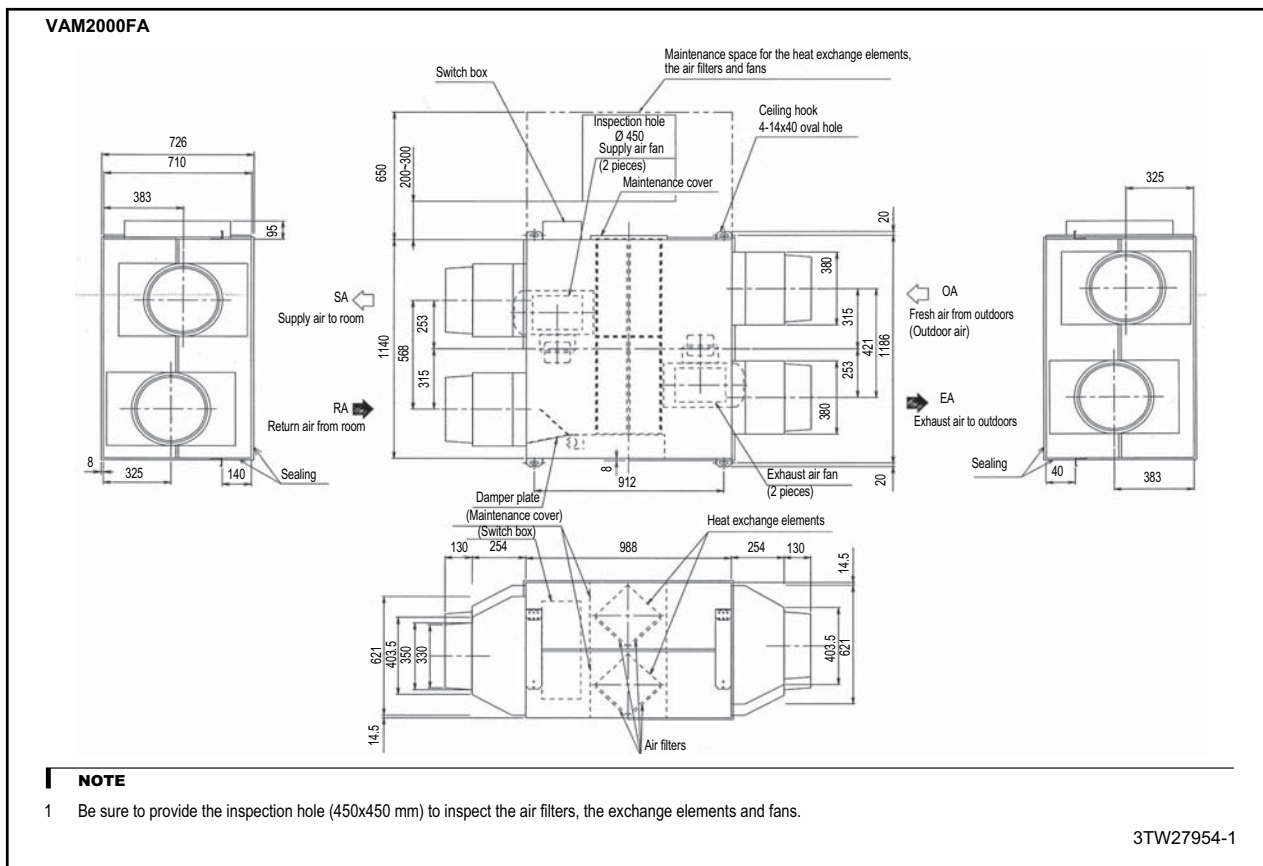

Remote control (BRC301B61)

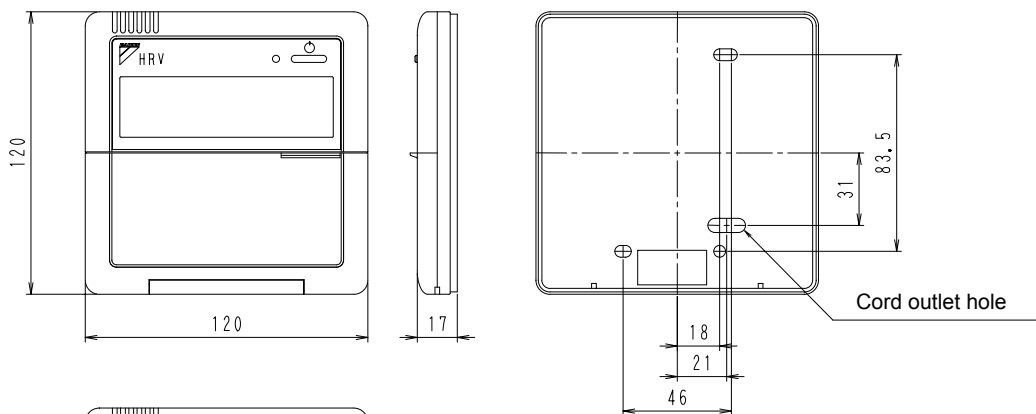

NOTE:

- Remote control cord and staple are not attached. They are field supplied parts. (However, they are attached to ceiling suspended type and wall mounted type of skyair series.)

Specifications of cord	
Type	Shielding wire (2 wires)
Size	0.75~1.25mm ²
Total length	500m

3D013155A

7 Product Specification

7 - 5 Wiring diagram

VAM150-1000FA

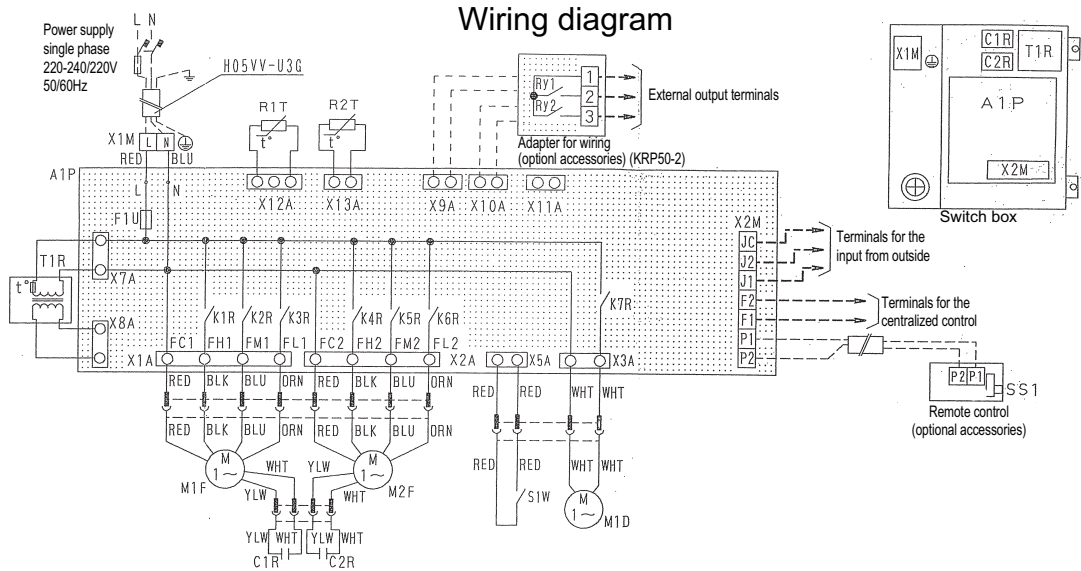

L - RED	N - BLU	M2F	Motor (exhaust fan motor)	Optional accessories	
A1P	Printed circuit board	Q1L • Q2L	Thermo switch (MF1 • 2 built-in)	Adapter for wiring (KRP50-2)	
C1R • C2R	Capacitor (M1F • M2F)	R1T	Thermistor (indoor air)	Ry1	Magnetic relay (On/Off)
F1U	Fuse (250V, 10A)	R2T	Thermistor (outdoor air)	Ry2	Magnetic relay (humidifier operation)
K1R ~ K3R	Magnetic relay (M1F)	S1W	Limit switch	X9A • 10A	Connector (KRP50-20)
K4R ~ K6R	Magnetic relay (M2F)	T1R	Transformer (supply 220-240V/22V)		Remote control
K7R	Magnetic relay (M1D)	X1M	Terminal (power supply)	SS1	Selector switch (main/sub)
M1D	Motor (damper motor)	X2M	Terminal (control)		Optional connector
M1F	Motor (air supply fan motor)			X11A	Connector (adapter power supply)

- : Terminals
 - ⊕ : Protective earth
 - ⊖ : Wire clamp
 - : Field wiring
 - ⊕ : Terminals for the input from outside
 - ⊖ : Terminals for the centralized control
 - ⊕ : Remote control (optional accessories)
- Colors: BLK: Black, GRN: Green, BLU: Blue, RED: Red, BRN: Brown, WHT: White, ORN: Orange, YLW: Yellow

2TW24836-1C

- ⚠ Before obtaining access to terminal devices, all power supply circuits must be interrupted.
- ⚠ Clean the heat exchange elements once every two years or more often and the air filter once a year or more often. (Before cleaning, make sure that the unit is not operating.)
- ⚠ To prevent electric shock hazards, provide grounding work according to the installation manual.

7 Product Specification

7 - 5 Wiring diagram

VAM1500,2000FA

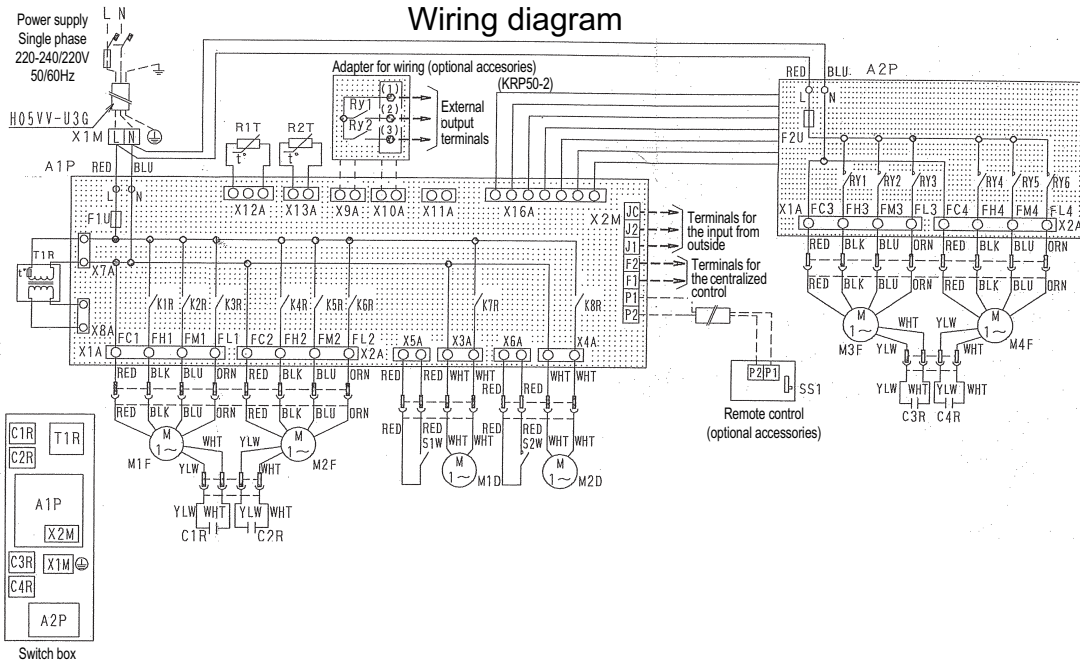

L - RED	N - BLU	M2F M4F	Motor (exhaust fan motor)	Optional accessories
A1P	Printed circuit board (control)	Q1L - Q4L	Thermo switch (M1F ~ M4F built-in)	Adapter for wiring (KRP50-2)
A2P	Printed circuit board (interface)	RY1 ~ RY3	Magnetic relay (M3F)	Ry1 Magnetic relay (On/Off)
C1R-C4R	Capacitor (M1F ~ M4F)	RY4 ~ RY6	Magnetic relay (M4F)	Ry2 Magnetic relay (humidifier operation)
F1U • F2U	Fuse (250V, 10A)	R1T	Thermistor (indoor air)	Remote control
K1R ~ K3R	Magnetic relay (M1F)	R2T	Terminal (outdoor air)	SS1 Selector switch (main/sub)
K4R ~ K6R	Magnetic relay (M2F)	S1W • S2W	Limit switch	Connector for optional parts
K7R	Magnetic relay (M1D)	T1R	Transformer (220-240V / 22V)	X9A Connector (for KRP50-2)
K8R	Magnetic relay (M2D)	X1M	Terminal (power supply)	X10A Connector (for KRP50-2)
M1D • M2D	Motor (damper motor)	X2M	Terminal (control)	X11A Connector
M1F • M3F	Motor (air supply fan motor)			

- : Terminals
 - : Connector
 - : Wire clamp
 - : Field wiring
 - : Protective earth
- Colors: BLK: Black GRN: Green
 BLU: Blue RED: Red
 BRN: Brown WHT: White
 ORN: Orange YLW: Yellow

2TW24906-1C

⚠ Before obtaining access to terminal devices, all power supply circuits must be interrupted.

⚠ Clean the heat exchange elements once every two years or more often and the air filter once a year or more often. (Before cleaning, make sure that the unit is not operating.)

⚡ To prevent electric shock hazards, provide grounding work according to the installation manual.

7 Product Specification

7 - 6 Sound level data

7-6-1 Overall sound pressure levels

Ventilation Mode		220V / 50Hz						230V / 50Hz					
		Total Heat Exchange mode			Bypass mode			Total Heat Exchange mode			Bypass mode		
Fan Speed		U-H	H	L	U-H	H	L	U-H	H	L	U-H	H	L
Model	VAM150FA	27	26	20.5	27	26.5	20.5	28	27	21	28	27	21
	VAM250FA	28	26	21	27.5	27	21	28.5	26.5	21.5	28	27.5	21.5
	VAM350FA	32	31.5	23.5	31.5	31	24.5	33	32	25	32	31.5	25.5
	VAM500FA	33	31.5	24.5	33.5	32.5	24	34	32.5	25.5	34	33	26.5
	VAM650FA	34.5	33	27	34.5	33	27	35	33.5	27.5	35	34.5	27
	VAM800FA	35.5	34.5	31	35.5	34.5	31	36.5	35.5	31.5	36.5	35.5	31.5
	VAM1000FA	36	35	31.5	36	35.5	32	36.5	35.5	31.5	36.5	35.5	32
	VAM1500FA	39.5	38	34	40.5	38	33	41	38.5	35	41	38.5	35
	VAM2000FA	40	38	35	41	38	33	41.5	40	36	41.5	40	35

Ventilation Mode		240V / 50Hz						220V / 60Hz					
		Total Heat Exchange mode			Bypass mode			Total Heat Exchange mode			Bypass mode		
Fan Speed		U-H	H	L	U-H	H	L	U-H	H	L	U-H	H	L
Model	VAM150FA	28.5	27.5	21.5	28.5	27.5	21.5	28.5	26.5	19	28	27	20
	VAM250FA	29	27	22	28.5	28	22	29.5	26	19.5	29	27	20.5
	VAM350FA	34	33	26	33.5	32.5	26.5	34.5	32	22	34.5	33	22
	VAM500FA	34.5	33	27.5	34.5	33.5	27.5	35.5	33.5	24	35	33	24
	VAM650FA	35.5	34	28	35.5	35	28.5	36	33	27	35.5	34	27
	VAM800FA	37	36	32	37	36	32	36	34.5	31	37	35	31
	VAM1000FA	37	36	32	37	36	33	37	35	31	37	35	31
	VAM1500FA	41.5	39	36	41.5	39	36	40.5	38	33	40.5	38	33
	VAM2000FA	41.5	40	38	42.5	41	37	41	38	34	41	38	35

7 Product Specification

7 - 6 Sound level data

7-6-2 Sound power spectrum

VAM150FA

[dB]

Model	Power supply	Hz/Notch	63	125	250	500	1000	2000	4000	8000	
VAM150FA7VE	220V	U-H	50	48	46	40.5	38.5	34	25.5	27	
		H	47	47	42	40	37.5	27.5	25	26.5	
		L	44	42	38.5	35.5	29.5	21.5	22.5	23.5	
	50Hz	230V	U-H	51	49	47	41.5	39.5	35	27	28.5
			H	47.5	47.5	42.5	39.5	37	28.5	26	27.5
			L	44	42	38.5	36	29.5	21.5	22.5	23.5
	240V	U-H	53	50.5	46.5	42	40	36.5	30	31.5	
		H	49.5	49.5	45	42	39.5	31.5	29.5	31.5	
		L	44.5	42.5	39.5	36	30	22.5	23.5	25	
	60Hz	220V	U-H	52	51	46	42.5	39.5	33.5	24.5	27
			H	49	49	44.5	40.5	37	29.5	26	27.5
			L	41	42	39	35.5	29	21	21.5	23.5

4D036765

VAM250FA

[dB]

Model	Power supply	Hz/Notch	63	125	250	500	1000	2000	4000	8000	
VAM250FA7VE	220V	U-H	51.1	51	48	42	38.5	33.5	25.5	25.5	
		H	49.5	48.5	46	40	36.5	29	22	23.5	
		L	44.5	44	42	34	28	19.5	21	22	
	50Hz	230V	U-H	52	51.5	47	43	39.5	34	27	27
			H	50.5	49.5	47	41	37.5	30	24.5	26
			L	44.5	44.5	42	35	28	19.5	21	22
	240V	U-H	51.5	52.5	48	44.5	41	36	29	29.5	
		H	52	52	48.5	40.5	38	32.5	28	30	
		L	45	44.5	43	34.5	28.5	21	22.5	23.5	
	60Hz	220V	U-H	51.5	52	49	43.5	39.5	34	25.5	25.5
			H	49	50	45.5	40	38	30	24.5	26
			L	44.5	41	39	34.5	30.5	20	20	22

4D036766

VAM350FA

[dB]

Model	Power supply	Hz/Notch	63	125	250	500	1000	2000	4000	8000	
VAM350FA7VE	220V	U-H	57.5	53	49.5	45	42.5	39.5	31.5	25.5	
		H	58.5	51	46.5	43.5	40.5	35	26	26.5	
		L	58.5	45.5	41.5	38	33.5	24	25	27	
	50Hz	230V	U-H	59.5	54	50.5	46	43.5	40.5	32.5	27.5
			H	60	52	49	46	42	36.5	29.5	28.5
			L	59.5	46	42.5	38.5	34.5	25	26	28
	240V	U-H	62	55.5	52	47.5	45	42	34.5	30	
		H	64	54.5	49.5	46	44	38.5	31	32	
		L	60	46.5	44	39	35	26	26.5	28.5	
	60Hz	220V	U-H	59	53.5	52.5	48.5	45	41	32.5	27.5
			H	61.5	52	49.5	46.5	41.5	37	28	30
			L	55.5	44	41	36	32.5	23.5	22.5	24

4D036767

VAM500FA

[dB]

Model	Power supply	Hz/Notch	63	125	250	500	1000	2000	4000	8000	
VAM500FA7VE	220V	U-H	57	54	51	48	45	37.5	27.5	25.5	
		H	54	51.5	49	46	42.5	36	26.5	26	
		L	50.5	47.5	44	39	33.5	25	23	24.5	
	50Hz	230V	U-H	57.5	54.5	51.5	48.5	45.5	38	28.5	26.5
			H	55	52.5	50	47	43.5	37	28	28
			L	51.5	48.5	45	39.5	34.5	26.5	25	26.5
	240V	U-H	58.5	55.5	52.5	49.5	46.5	39	29.5	28.5	
		H	56.5	54	51.5	48.5	45.5	38.5	30	30	
		L	52	48.5	45.5	40	34.5	27	25.5	27.5	
	60Hz	220V	U-H	57.5	54	51	49	46.5	39	29	25.5
			H	55	52	49.5	47	44	36	26.5	26
			L	51	47	44	39.5	33	23.5	22.5	25.5

4D036768

VAM650FA

[dB]

Model	Power supply	Hz/Notch	63	125	250	500	1000	2000	4000	8000	
VAM650FA5/7VE	220V	U-H	62	58	52.5	48.5	45.5	41.5	34	26	
		H	61	56.5	51	47	44.5	39	30	26	
		L	53.5	50.5	46	42	37.5	32	24	25.5	
	50Hz	230V	U-H	62.5	58.5	53	49	46	42	35	27
			H	61.5	57	51.5	47.5	45	39.5	30.5	27
			L	54.5	51.5	47	43	38.5	33	26	27.5
	240V	U-H	63.5	59.5	54	50	47	43	36	28.5	
		H	63	58.5	53	49	46.5	41.5	32.5	29.5	
		L	56	43	48.5	44.5	40	34.5	28	30	
	60Hz	220V	U-H	59.5	58	53.5	48.5	46	43	38	23
			H	61.5	56	51	47	44	40	30	26.5
			L	54	51	46	42	38.5	31	23	25.5

4D036769

Measuring place

Notes:

1. Operation sound is measured in an anechoic chamber.
2. The operating sound level may become greater than this value depending on the operating conditions, reflected sound and peripheral noise.
3. Operation sound differs with operation and ambient conditions.
4. The power levels have been calculated on the assumption that the measuring point is right under the source of operating sound.
5. U-H: Ultra high
H: High
L: Low

7 Product Specification

7 - 6 Sound level data

7-6-2 Sound power spectrum

VAM800FA

[dB]

Model	Power supply		Hz/Notch	63	125	250	500	1000	2000	4000	8000
	VAM800FA5/7VE	50Hz	220V	U-H	58	58	52.5	49.5	48.5	41.5	33.5
H				58.5	57	51.5	49.5	47	40.5	31	27.5
L				54.5	54.5	47.5	44.5	43	35.5	24.5	23.5
240V			U-H	58.5	59.5	53	50	49	42	34	27
			H	59	58.5	52	50	47.5	41	31.5	28.5
			L	55.5	54	49.5	46.5	44	37.5	27.5	28
60Hz		220V	U-H	59	58	53	50	49	43.5	34.5	27
			H	59.5	59	52.5	50.5	48	41.5	32	29.5
			L	58	58	51	48	46.5	39	29.5	30.5
		240V	U-H	58	57.5	54	50.5	49	43	33.5	26
			H	58.5	57.5	52.5	50	47	39.5	30	27
			L	54	54	48.5	45	43	35	24	23.5

4D036770

VAM1000FA

[dB]

Model	Power supply		Hz/Notch	63	125	250	500	1000	2000	4000	8000
	VAM1000FA5/7VE	50Hz	220V	U-H	62	58.5	54	50.5	49	42	36.5
H				61	57	52	50	48	38.5	31	25.5
L				58	55	49	45.5	43.5	36.5	27.5	24
230V			U-H	62.5	57.5	54.5	51	49.5	42.5	37	29
			H	61.5	57.5	52.5	50.5	48.5	39	31.5	26.5
			L	58.5	55	49	47	43.5	37	28	25
60Hz		240V	U-H	62.5	59	54.5	51.5	50.5	42.5	37	29
			H	62	58	53	51	49	39.5	32	27.5
			L	59	55.5	49.5	47.5	44	37.5	29	26
		220V	U-H	62.5	57.5	53.5	52	49.5	42	36	27
			H	61	57	52	50	48	38	30	24.5
			L	59	54	51	47.5	43	35.5	26	24.5

4D036771

VAM1500FA

[dB]

Model	Power supply		Hz/Notch	63	125	250	500	1000	2000	4000	8000
	VAM1500FA5/7VE	50Hz	220V	U-H	60.5	61	55.5	52.5	50.5	46	39.5
H				60.5	60	53.5	51.5	49.5	44.5	37	31
L				58.5	58	51	49	47	39.5	30.5	31
230V			U-H	61	61.5	57	54.5	52	48.5	41.5	30.5
			H	61	60.5	54.5	52.5	49.5	43	34	31.5
			L	59.5	59.5	52	49.5	48	40.5	31.5	32
60Hz		240V	U-H	61.5	63	59	56	53	46.5	40	32
			H	61	60.5	54	52	49.5	43	34	31.5
			L	60	60	52.5	50	48.5	41	32	32.5
		220V	U-H	62	62	57	54.5	52	46	37	31
			H	61	60.5	56	53	50	42.5	33	31.5
			L	59.5	59	51.5	49	45.5	39.5	31.5	32.5

4D036772

VAM2000FA

[dB]

Model	Power supply		Hz/Notch	63	125	250	500	1000	2000	4000	8000
	VAM2000FA5/7VE	50Hz	220V	U-H	65	61.5	57	54	53	45	39.5
H				64	60	55	53	51	41.5	34.5	30.5
L				62	58	51.5	50	48.5	40.5	32.5	30.5
230V			U-H	65.5	62	58	55.5	53.5	45.5	40	33
			H	65	61	56.5	54	52	42.5	35.5	32
			L	62	59	53	50.5	48.5	40.5	33	31
60Hz		240V	U-H	66	62.5	58	55	54	46	40.5	33.5
			H	65	61	56	54	52	42.5	35.5	32
			L	63	60	54.5	52	50	41.5	34	32.5
		220V	U-H	66.5	61.5	57.5	56	53.5	46	40.5	33
			H	64	60	55	53	51	41	33.5	30
			L	60.5	57.5	51	48.5	46.5	41	32.5	32.5

4D036837

Measuring place

Notes:

1. Operation sound is measured in an anechoic chamber.
2. The operating sound level may become greater than this value depending on the operating conditions, reflected sound and peripheral noise.
3. Operation sound differs with operation and ambient conditions.
4. The power levels have been calculated on the assumption that the measuring point is right under the source of operating sound.

7 Product Specification

7 - 6 Sound level data

7-6-3 Sound pressure spectrum

	VAM150FA	VAM250FA	VAM350FA
50Hz 220V	<p>Octave band sound pressure level dB (0dB = 0.0002 μbar)</p> <p>Octave band center frequency (Hz)</p> <p>4D036868</p>	<p>Octave band sound pressure level dB (0dB = 0.0002 μbar)</p> <p>Octave band center frequency (Hz)</p> <p>4D036870</p>	<p>Octave band sound pressure level dB (0dB = 0.0002 μbar)</p> <p>Octave band center frequency (Hz)</p> <p>4D036871</p>
50Hz 230V	<p>Octave band sound pressure level dB (0dB = 0.0002 μbar)</p> <p>Octave band center frequency (Hz)</p> <p>4D036878</p>	<p>Octave band sound pressure level dB (0dB = 0.0002 μbar)</p> <p>Octave band center frequency (Hz)</p> <p>4D036879</p>	<p>Octave band sound pressure level dB (0dB = 0.0002 μbar)</p> <p>Octave band center frequency (Hz)</p> <p>4D036880</p>
50Hz 240V	<p>Octave band sound pressure level dB (0dB = 0.0002 μbar)</p> <p>Octave band center frequency (Hz)</p> <p>4D036887</p>	<p>Octave band sound pressure level dB (0dB = 0.0002 μbar)</p> <p>Octave band center frequency (Hz)</p> <p>4D036888</p>	<p>Octave band sound pressure level dB (0dB = 0.0002 μbar)</p> <p>Octave band center frequency (Hz)</p> <p>4D036889</p>
60Hz 220V	<p>Octave band sound pressure level dB (0dB = 0.0002 μbar)</p> <p>Octave band center frequency (Hz)</p> <p>4D036896</p>	<p>Octave band sound pressure level dB (0dB = 0.0002 μbar)</p> <p>Octave band center frequency (Hz)</p> <p>4D036897</p>	<p>Octave band sound pressure level dB (0dB = 0.0002 μbar)</p> <p>Octave band center frequency (Hz)</p> <p>4D036898</p>

7 Product Specification

7 - 6 Sound level data

7-6-3 Sound pressure spectrum

	VAM500FA	VAM650FA	VAM800FA
50Hz 220V	<p>4D036872</p>	<p>4D036873</p>	<p>4D036874</p>
50Hz 230V	<p>4D036881</p>	<p>4D036882</p>	<p>4D036883</p>
50Hz 240V	<p>4D036890</p>	<p>4D036891</p>	<p>4D036892</p>
60Hz 220V	<p>4D036899</p>	<p>4D036890</p>	<p>4D036901</p>

7 Product Specification

7 - 6 Sound level data

7-6-3 Sound pressure spectrum

	VAM1000FA	VAM1500FA	VAM2000FA
50Hz 220V	<p>4D036875</p>	<p>4D036876</p>	<p>4D036877</p>
50Hz 230V	<p>4D036884</p>	<p>4D036885</p>	<p>4D036886</p>
50Hz 240V	<p>4D036893</p>	<p>4D036894</p>	<p>4D036895</p>
60Hz 220V	<p>4D036902</p>	<p>4D036903</p>	<p>4D036904</p>

7 Product Specification

7 - 7 Fan performance

VAM150FA

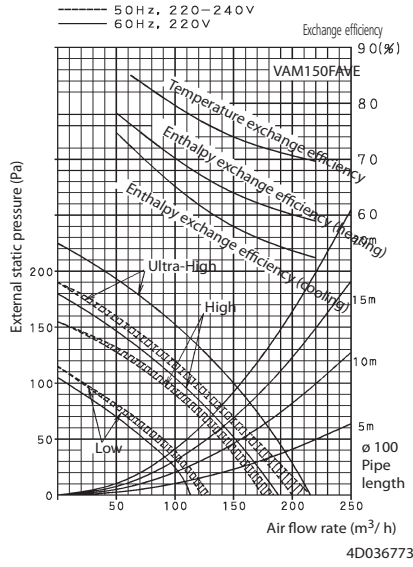

VAM250FA

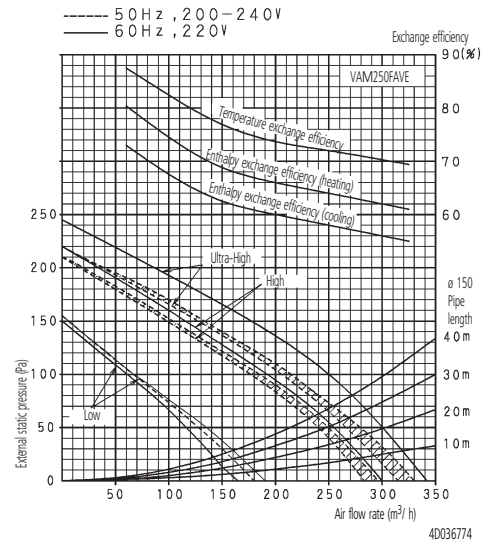

VAM350FA

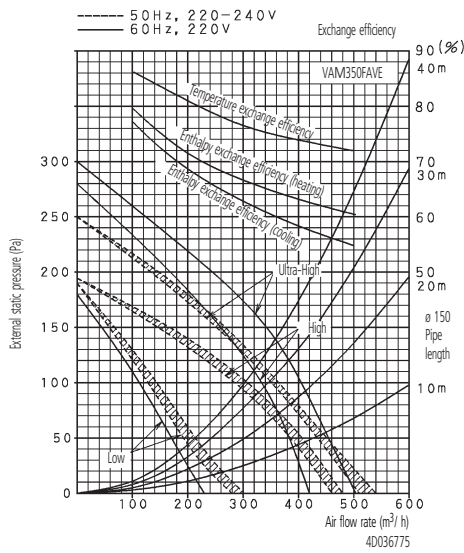

VAM500FA

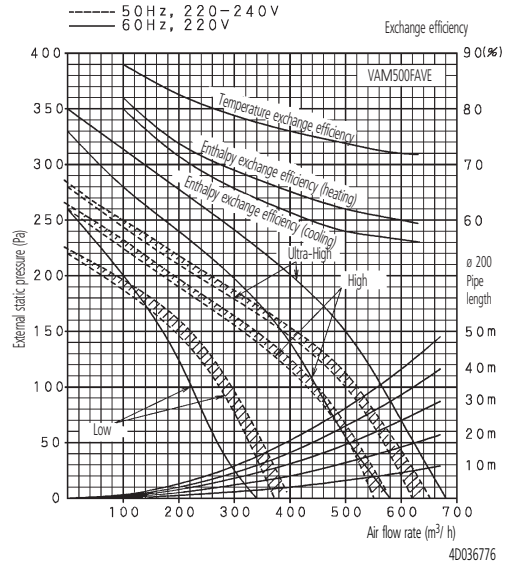

VAM650FA

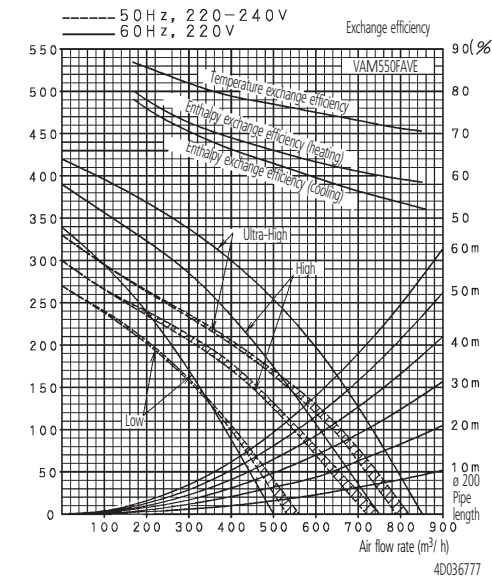

7 Product Specification

7 - 7 Fan performance

VAM800FA

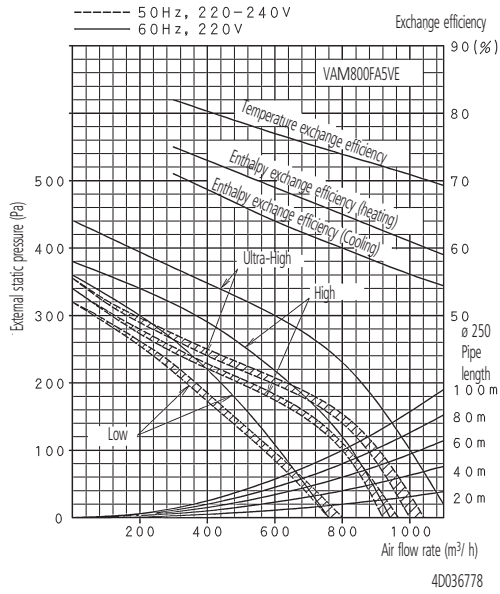

VAM1000FA

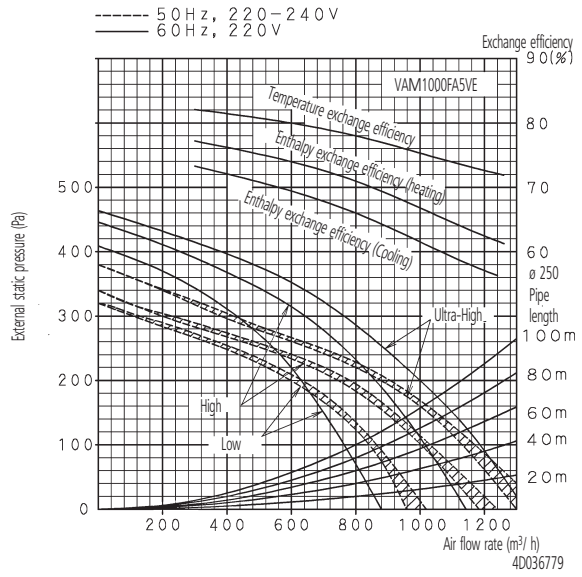

VAM1500FA

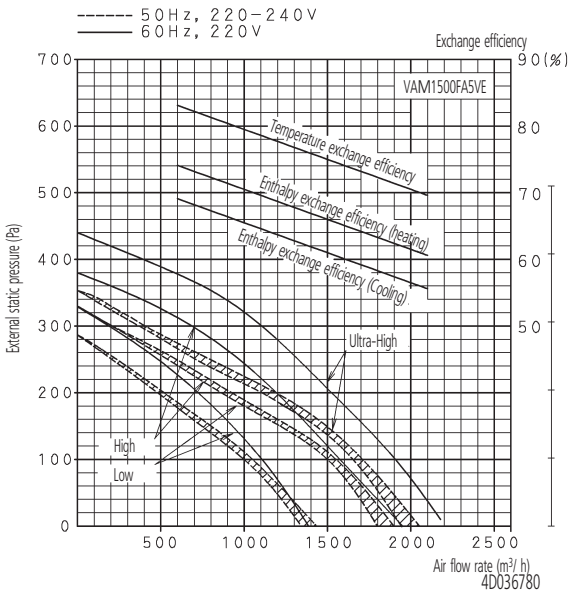

VAM2000FA

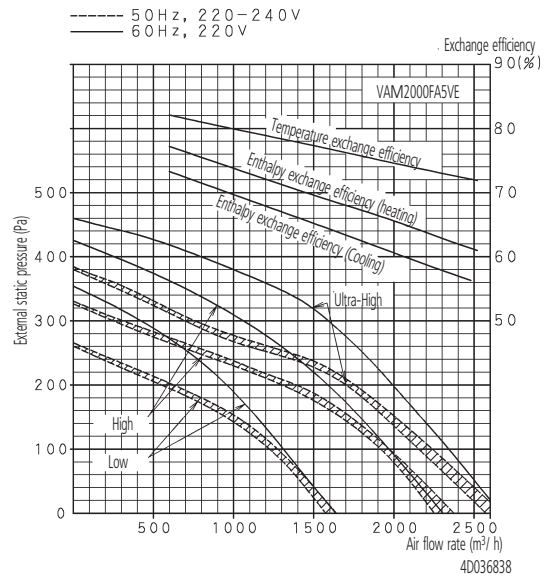

7 Product Specification

7 - 8 Installation method

VAM150FA

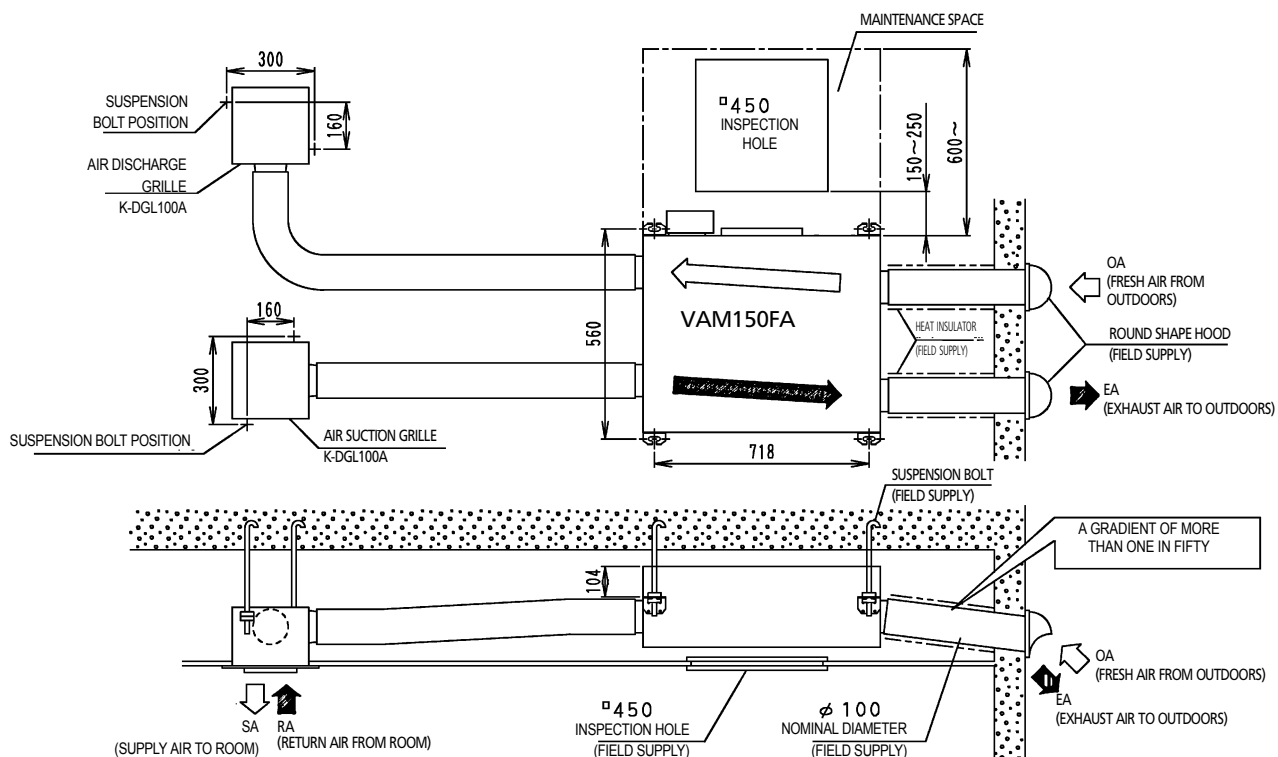

3D036781

VAM250FA

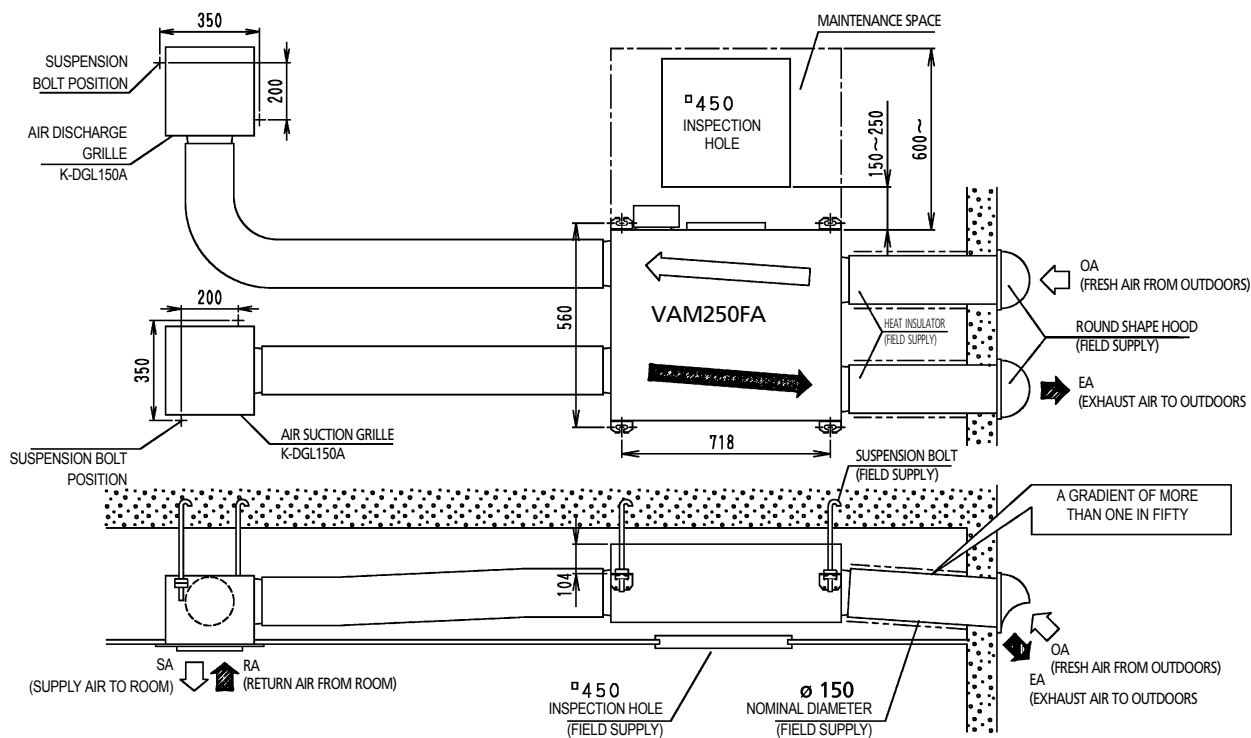

3D036782

7 Product Specification

7 - 8 Installation method

VAM350FA

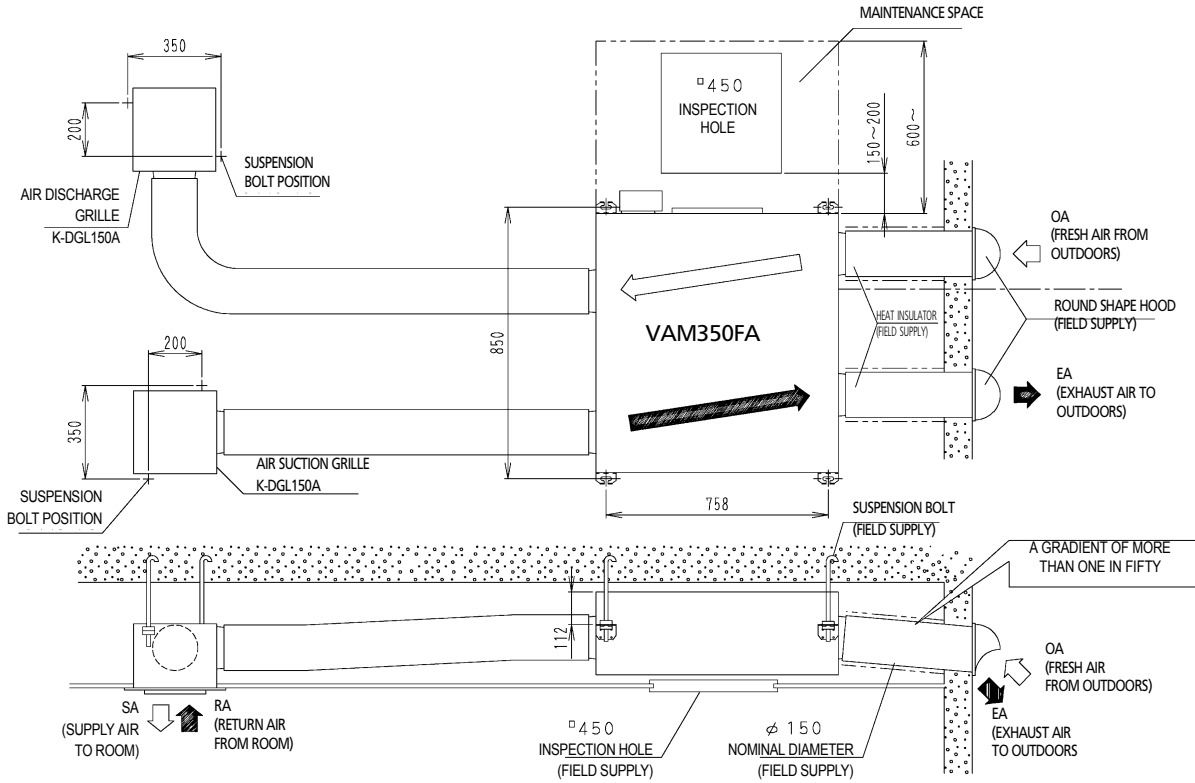

3D036786

VAM500FA

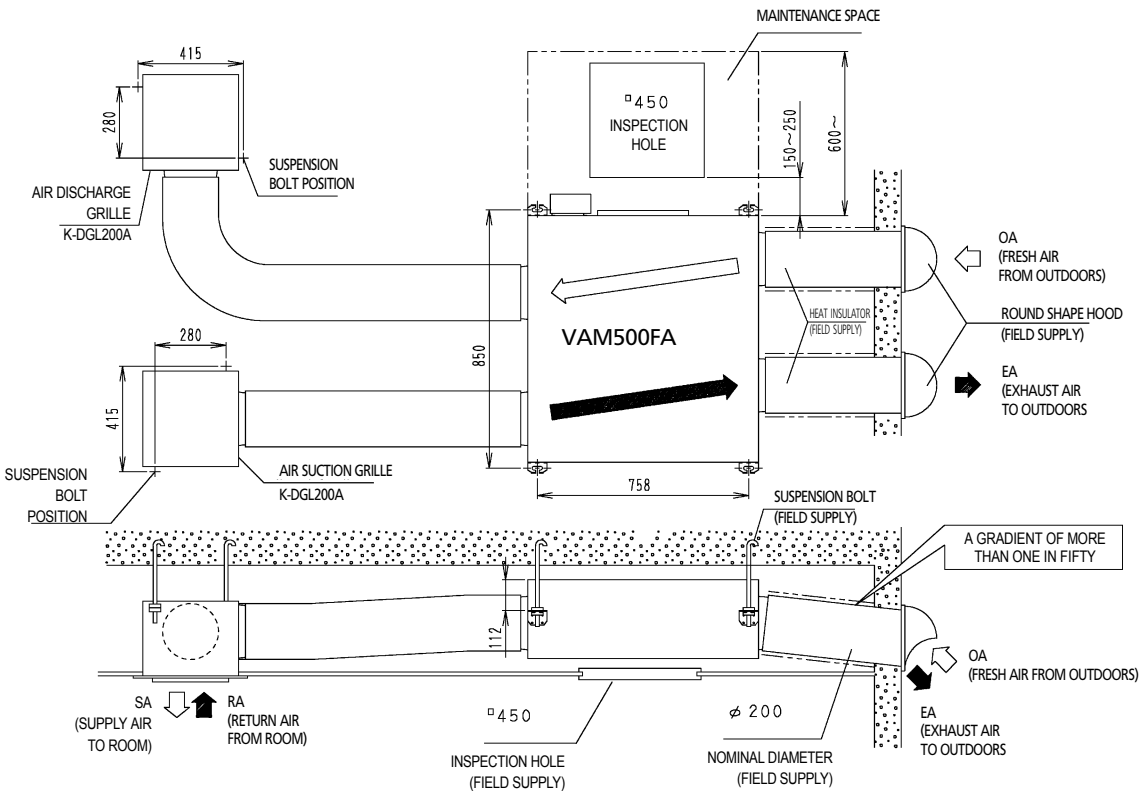

3D036787

7 Product Specification

7 - 8 Installation method

VAM650FA

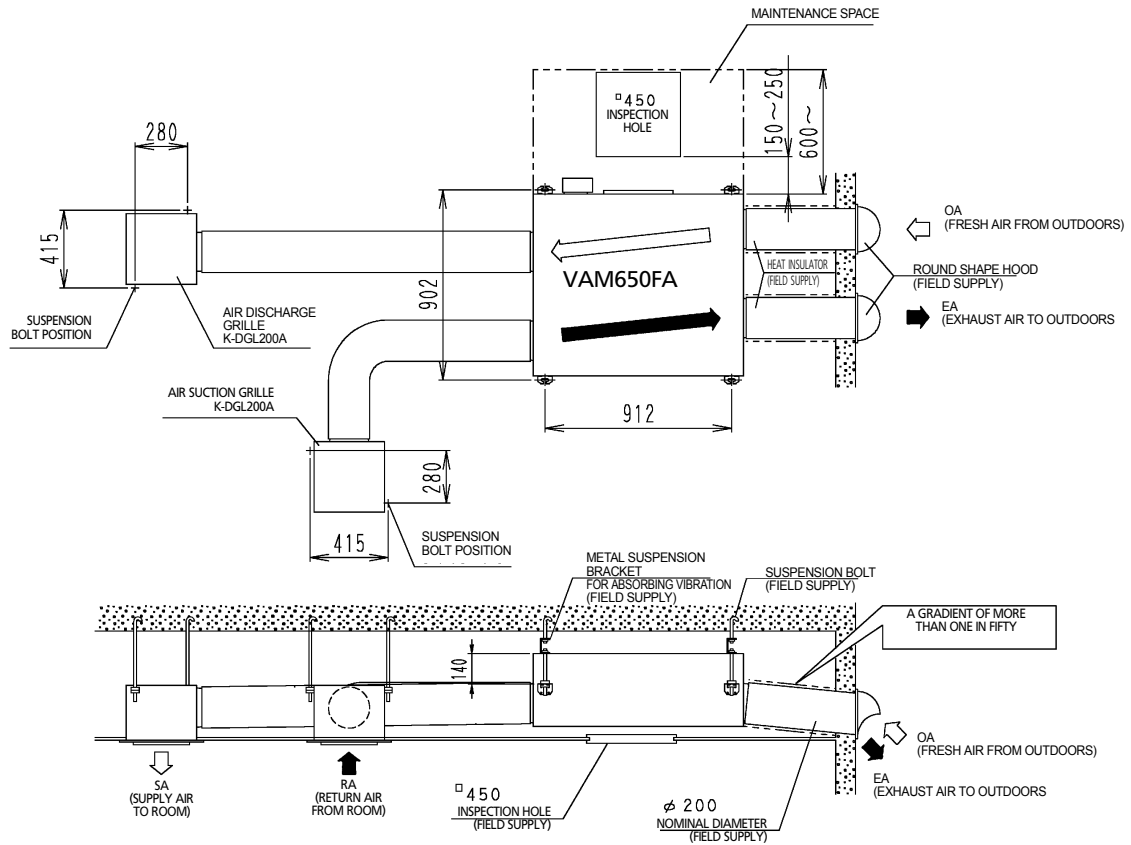

3D036788

VAM800FA

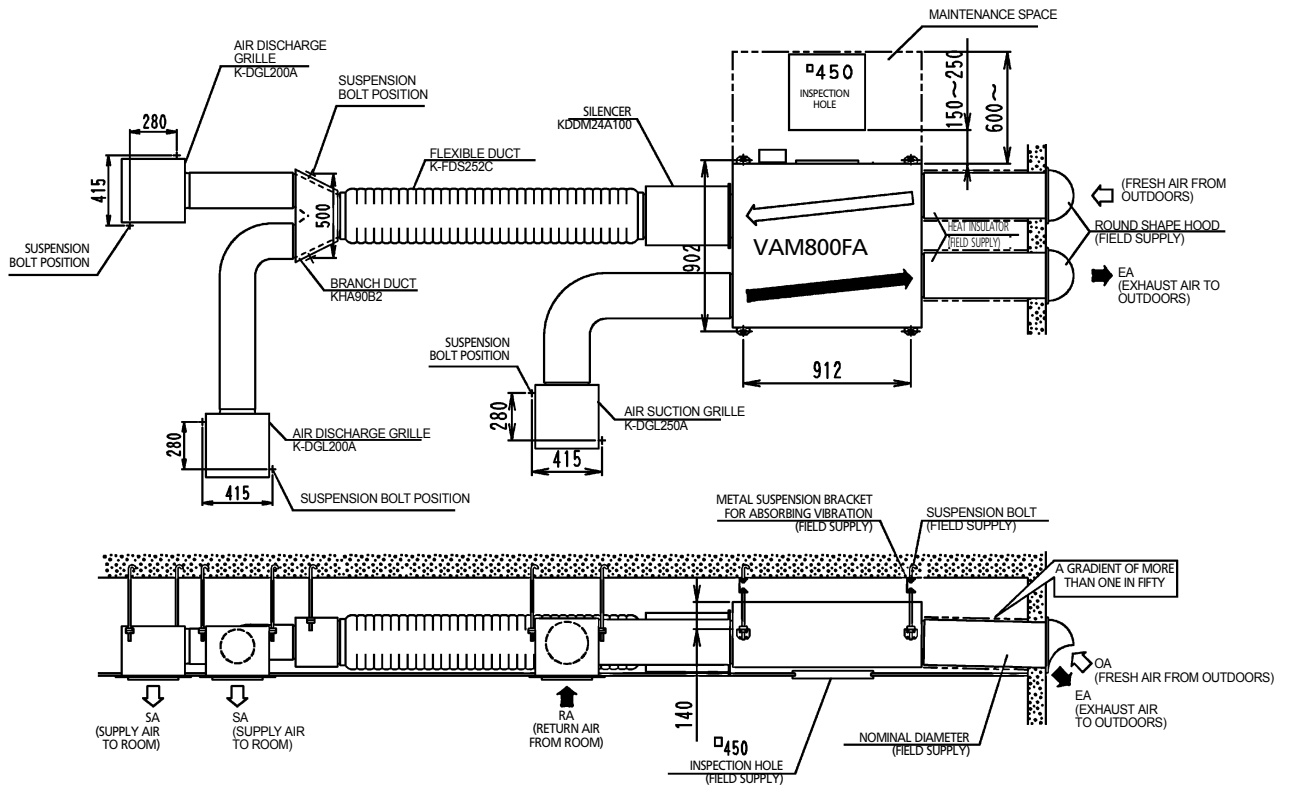

3D036789

7 Product Specification

7 - 8 Installation method

VAM1000FA

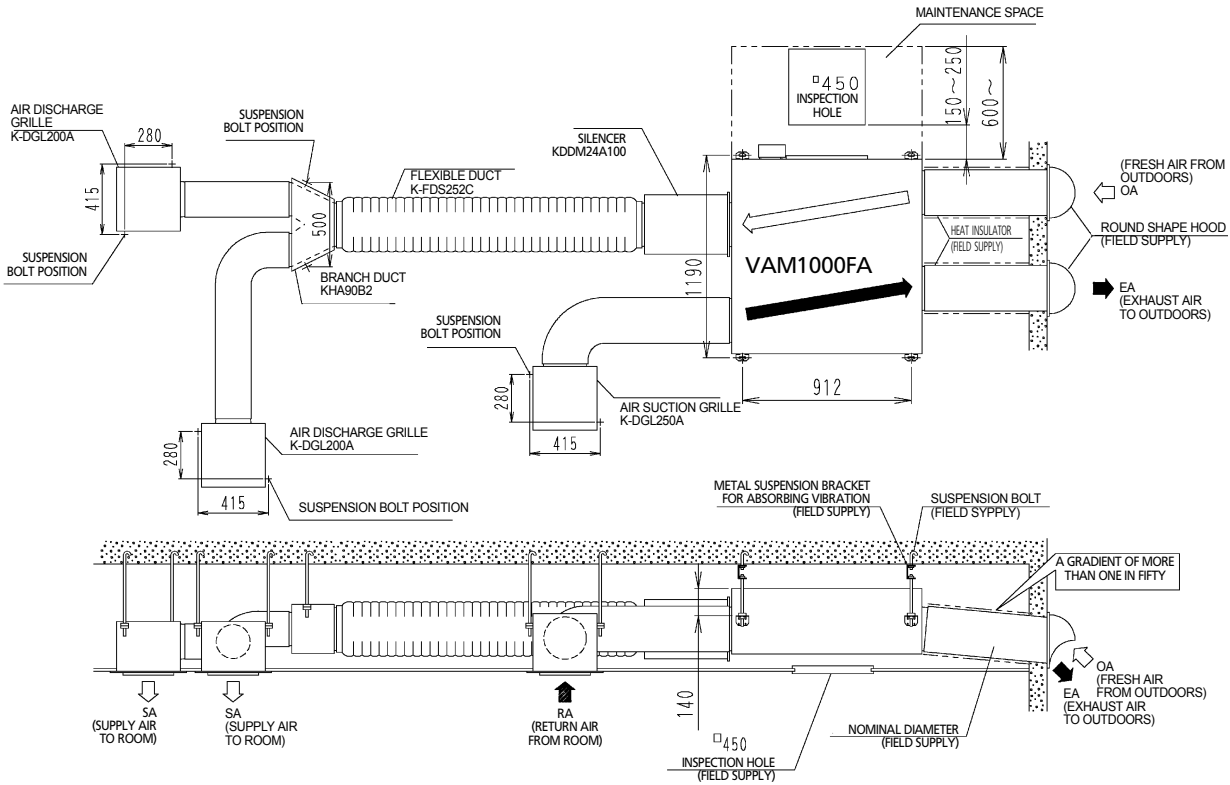

3D036790

VAM1500FA

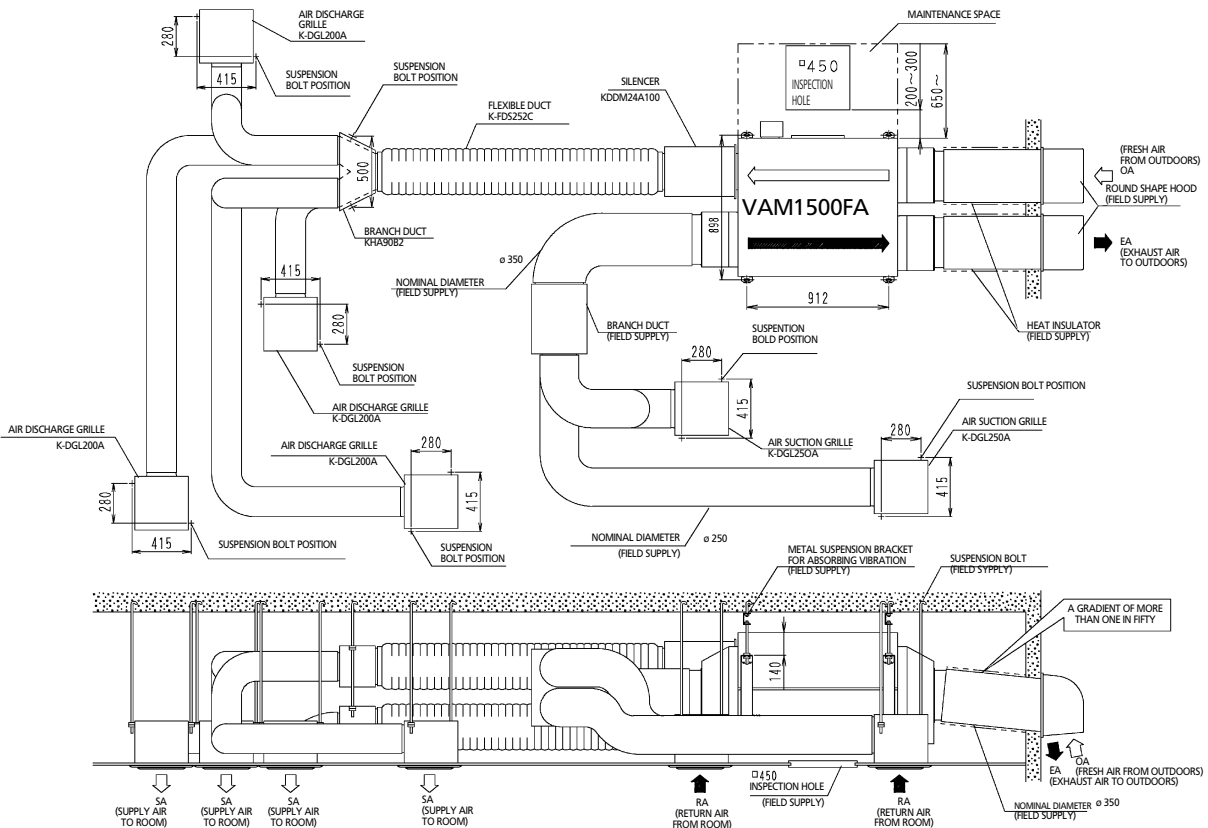

3D036791

7 Product Specification

7 - 8 Installation method

VAM2000FA

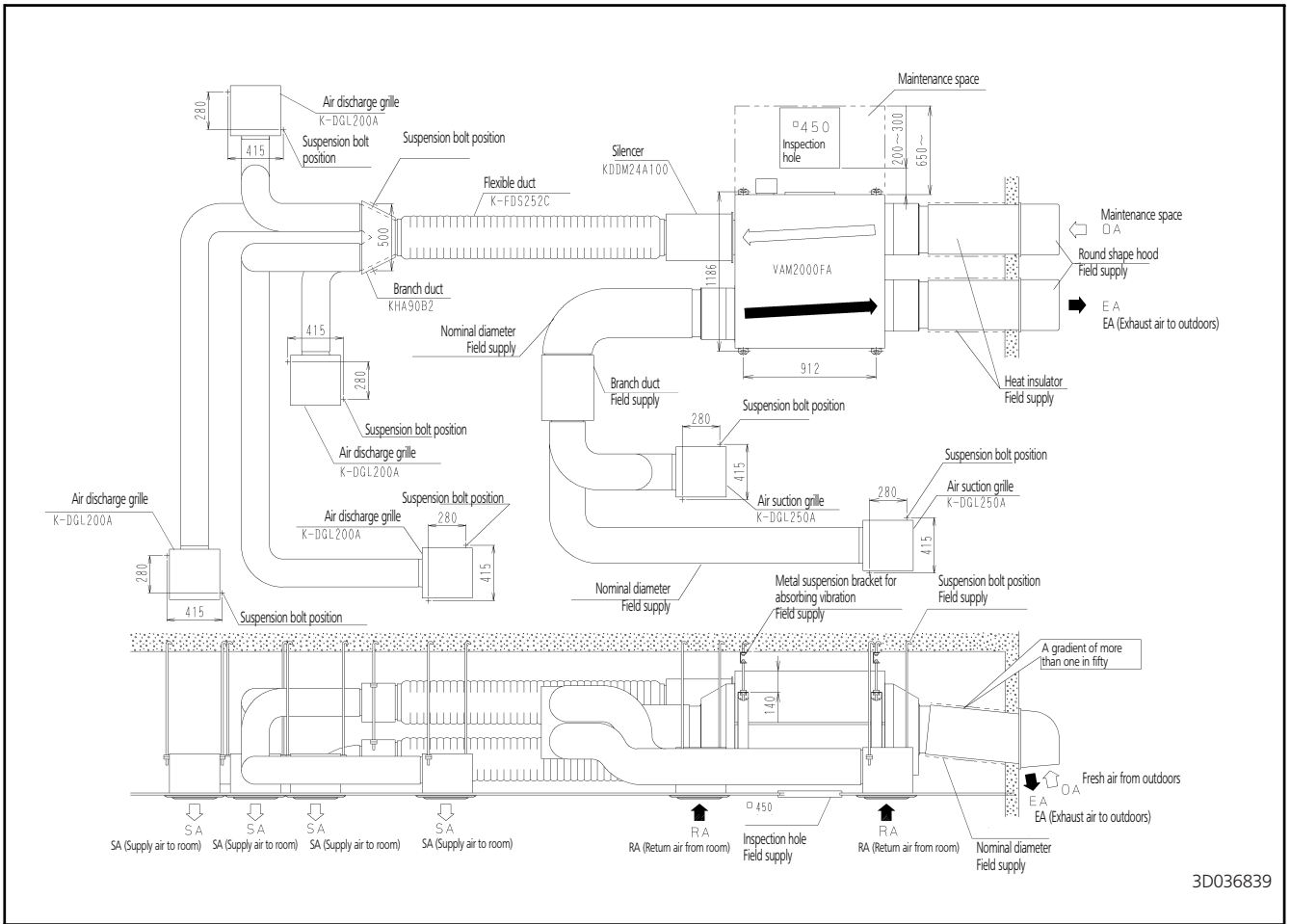

8 Operation

8 - 1 Method of operation

8-1-1 Operation with the remote control exclusively for Air conditioning operation HRV units. (BRC301B61)

For non-independent systems, starting / stopping operation and timer operation may not be possible.

Use the air conditioner remote control or the Centralized control in such cases.

- ① Operation lamp
This pilot lamp (red) lights up while the unit is in Operation.
- ② Operation / Stop button
When pushed once, the unit starts operating.
When pushed twice, the unit stops.

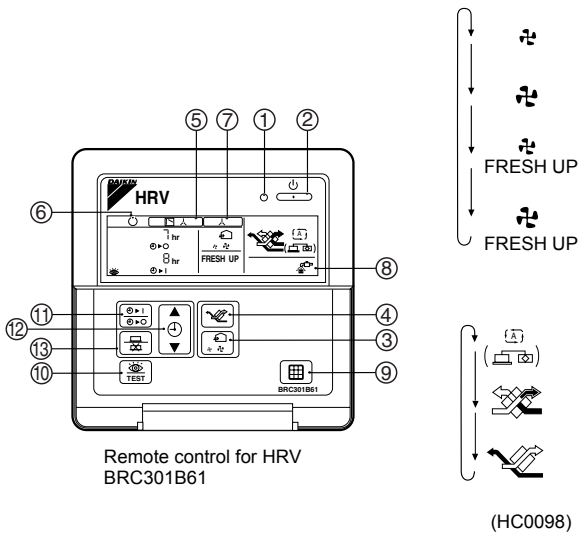

- ③ Air flow rate changeover button
Air flow rate can be changed over to “↻” [Low] mode or “↻” [High] mode, “↻ FRESH UP” [Low FRESH UP] mode, “↻ FRESH UP” [High FRESH UP] mode.
For “FRESH UP” operation:
When this indication does not show: the volume of outdoor air supplied into the room and that of the room air exhausted outdoors is equivalent.
For “FRESH UP” operation:
 - If it is set to “Fresh up air supply”: The volume of outdoor air supplied into the room is larger than that of room air exhausted outdoors. (This operation prevents the odor and moisture from kitchens and toilets from flowing into the rooms.)
 - If it is set to “Fresh up air exhaust”: The volume of room air exhausted outdoors is larger than that of outdoor air supplied into the room. (This operation prevents the hospital odor and floating bacteria from flowing out to the corridors.)
- ④ Ventilation mode changeover button
“⊞” (Automatic) mode The temperature sensor of the unit automatically changes the ventilation of the unit in [Bypass] mode and [Heat Exchange] mode.
“↻” (Heat Exchange) mode In this mode, the air passes through the heat exchange element to effect [Total Heat Exchanging] ventilation.
“↻” (Bypass) mode In this mode, the air does not pass through the heat exchange element but passes it to effect [Bypass] ventilation.

- ⑤ Indication of operation control method:
When the operation of HRVs are interlocked with the air conditioners, this indication may be shown. While the indication is shown, the ON / OFF of HRVs cannot be operated by the HRV remote control.
- ⑥ Indication of operation standby:
It indicates the precooling / preheating operation. This unit is at stop and will start operation after the precooling / preheating operation is over. Precooling / preheating operation means the operation of HRVs is delayed during the startup operation of interlocked air conditioners such as before the office hours. During this period the cooling or heating load is reduced to bring the room temperature to the set temperature in a short time.
- ⑦ Indication of centralized control:
When a remote control for air conditioners or devices for centralized control are connected to the HRVs, this indication may show.
During this indication appears on the display, the ON / OFF and timer operation may not be possible with the HRV remote controls.
- ⑧ Indication of air filter cleaning
When the indication “↻” appears on the display, clean the filter.
- ⑨ Filter signal reset button
- ⑩ Inspection button
This button is to be used only for service. It is not to be used normally.

How To Operate With Timer

- ⑪ Push the button “⊞” and select either one of “⊞▶○” or “⊞▶▶”.
Each time the button is pushed, the indication changes as shown below.

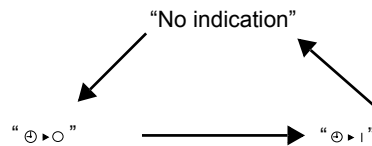

- ⑫ Push the button “⊞” and set the time.
Each time when “▲” is pushed, the time advances one hour.
Each time when “▼” is pushed, the time goes back one hour.
- ⑬ Push the button “⊞”.
Then, the reservation is finished.
Either “⊞▶○” or “⊞▶▶” changes from flashing to lighting. After the reservation is finished, the remaining time is indicated in the display.
For cancelling the timer operation, push the button “⊞” once again.
The indication disappears.

8 Operation

8 - 1 Method of operation

8-1-2 Operating the HRV unit using the remote control of the VRV- system air conditioner

When the VRV-system air conditioner is connected with the HRV unit with a direct duct, the remote control of the air conditioner cannot be used to select the VENTILATION mode. To use the HRV unit without operating the air conditioner, set the air conditioner in the FAN VENTILATION mode and select the low fan speed.

- ① Operation lamp
- ② Operation / stop button
- ③ Operation mode display
- ④ Operation mode selector

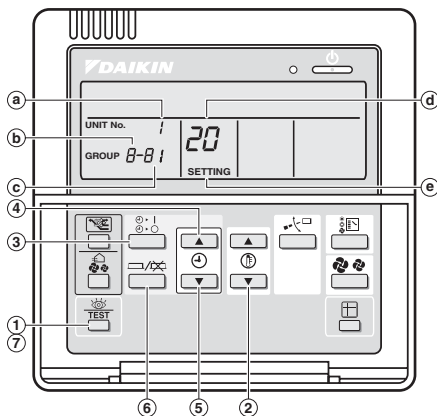

Remote control for indoor unit

(HC0099)

- Every time the operation mode selector is pressed, the operation mode display changes as shown below.

example

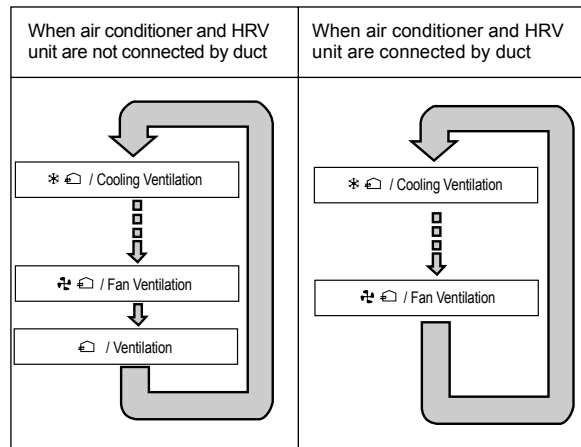

(HC0100)

- When the “ FILTER” indication appears on the display, clean the filter of the HRV unit. (Refer to the section 3.)

8-1-3 Independent operation of the HRV unit using the Centralized control (DCS302B61)

- After selecting the zone where the only the HRV unit operation is desired, press the operation mode selector and select “” VENTILATION. The HRV unit can then be operated independently from the air conditioner.
- When the “FILTER” indication appears on the display, clean the filter of the HRV unit. (Refer to the section 3.)

8 Operation

8 - 2 Cautions in use

▲WARNING

Never inspect or service the unit by yourself.
Ask a qualified service person to perform this work.
(The qualified service person)

▲WARNING

Before obtaining access to terminal devices(⚠), all power supply circuit must be interrupted.

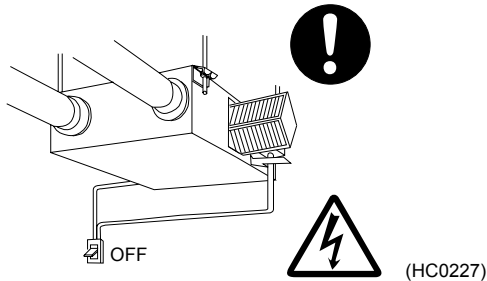

Electric shock may result. Before servicing the unit, always shut off power.



▲WARNING

Always use the air filter.
If the air filter is not used, heat exchange elements will be clogged, possibly causing poor performance and subsequent failure.

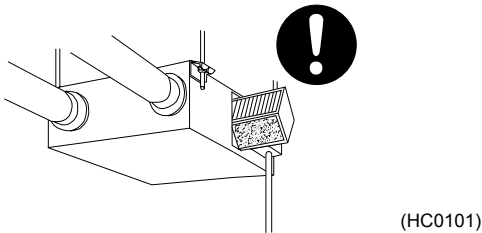

▲WARNING

Do not change operations suddenly. It can result not only in malfunction but also failure of switches or relays in the body.

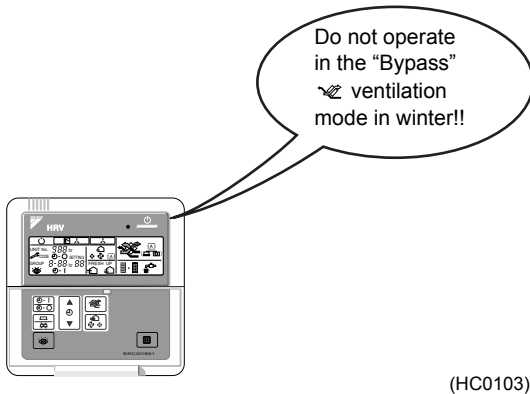
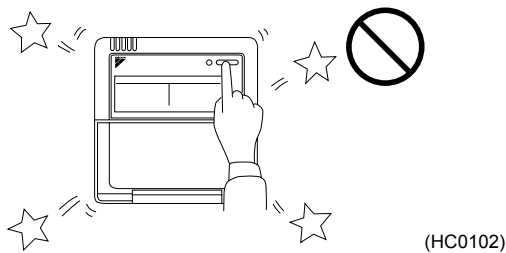

8-2 Maintenance

(for a qualified service person only)

▲CAUTION

Only a qualified service person is allowed to perform maintenance.
During operation, never check or clean the HRV. It may cause electrical shock and it is very dangerous to touch the rotating part.
Be sure to turn off the OPERATION switch and disconnect the power.

— CLEANING FREQUENCY — AIR FILTER

AT LEAST ONCE A YEAR

(FOR GENERAL OFFICE USE)

(CLEAN THE ELEMENT MORE FREQUENTLY IF NECESSARY.)

1. Go into the ceiling through the inspection hole, remove the hanging metals of maintenance cover and take it off.

VAM150 - 1000FA

VAM1500 - 2000FA

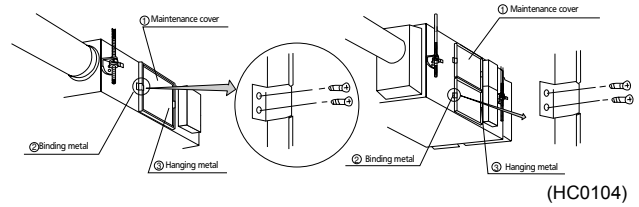

- 2.

VAM150 - 1000FA

VAM1500 - 2000FA

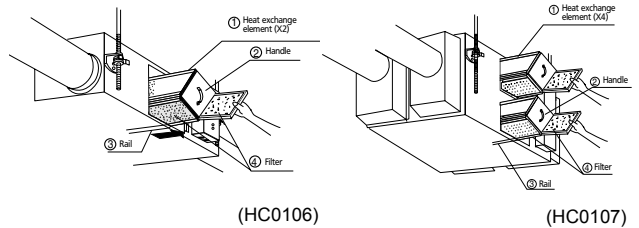

3. Take out the air filter.

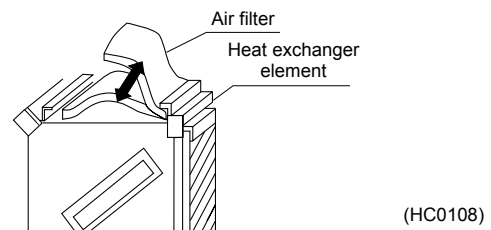

4. To clean the air filter, lightly pat it with hand or remove dust with a vacuum cleaner. If excessively dirty, wash it with neutral detergent.

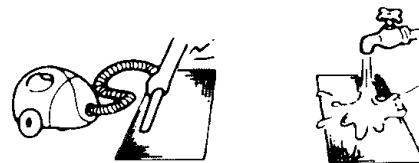

5. If the air filter is washed, remove water completely and allow to dry for 20 to 30 minutes in the shade. When dried completely, install the air filter back in place.
(Direct the indication "INSIDE" of the air filter toward the heat exchange element.)
6. Install the maintenance cover securely in place.

8 Operation

8 - 3 Maintenance

▲CAUTION

1. Do not wash the air filter in hot water.
2. Do not dry the air filter over a fire.
3. Do not subject the air filter to direct sunlight.
4. Do not use organic solvent such as gasoline and thinner on the air filter.
5. Be sure to install the air filter after servicing.
(Missing air filter causes clogged heat exchange element.)

The air filter is an optional item and the replacement is available.

— CLEANING FREQUENCY —
AT LEAST ONCE EVERY TWO YEARS
(FOR GENERAL OFFICE USE)
(CLEAN THE ELEMENT MORE FREQUENTLY IF NECESSARY.)

1. Use a vacuum cleaner to remove dust and foreign objects on the surface of the heat exchange element.

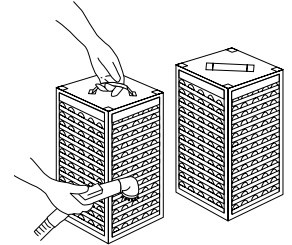

(HC0218)

Use the vacuum cleaner equipped with a brush on the tip of the suction nozzle.
 Lightly contact the brush on the surface of the heat exchanging element when cleaning. (Do not crush the heat exchange element while cleaning.)

2. Install the air filter securely in place.

3. Put the heat exchange element on the rail and insert it securely in place.
4. Install the maintenance cover securely in place.

▲CAUTION
 Never wash the heat exchanger element with water.

8 - 4 Trouble shooting

8-4-1 If your unit does not operate properly, check the following items.

Conditions	Causes	Corrective actions
The unit does not operate at all.	Check if there is a power failure.	After power has been restored, start operation again.
	Check if the fuse has blown or breaker has worked.	Change the fuse or set the breaker.
	Check if the indication of operation control method on remote control (BRC301B61) is shown.	This is normal. Operate the unit using the air conditioner remote control or centralized control. (Refer to "2. OPERATION")
	Check if the indication of operation stand by on remote control (BRC301B61) is shown.	It indicates the precooling / preheating operation. This unit is at stop and will start operation after the precooling / preheating operation is over. (Refer to "2. OPERATION".)
Amount of discharged air is small and the discharging sound is high.	Check if the air filter and heat exchange element are clogged.	Refer to "3. MAINTENANCE".
Amount of discharged air is large and so is the sound.	Check if the air filter and heat exchange element are installed.	Refer to "3. MAINTENANCE".

8-4-2 If the following occurs, consult your dealer where the unit was purchased.

<List of malfunction codes of Remote control of the HRV-system air conditioner>

Operation lamp	Inspection indicator	Unit No.	Malfunction code	Description
On	Off	Blinking	64	Indoor air thermistor malfunction
On	Off	Blinking	65	Outdoor air thermistor malfunction
On	Off	Blinking	6A	Dumper-related malfunction
Blinking	Blinking	Blinking	6A	Dumper-related malfunction + thermistor
Blinking	Blinking	Blinking	U5	Transmission error between the unit and remote control
Off	Blinking	Off	U5	Printed circuit board error or setting error of remote control
Off	Blinking	Off	U8	Transmission error between main remote control and sub remote control
Off	Blinking	Blinking	UA	Faulty installation setting
On	Blinking	On	UC	Repeated central address
Blinking	Blinking	Blinking	UE	Transmission error between the unit and centralized control

In case of the malfunction with the code in white letters on the black background in the unit still operates. However, be sure to have it inspected and repaired and as soon as possible.

9 Control System

9 - 1 Introduction of control system

The control systems introduced here is for the HRV unit adopting the high speed and high performance transmission system (DIII-NET), the same as the VRV systems and SkyAir series,

Description of system

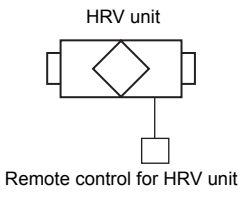
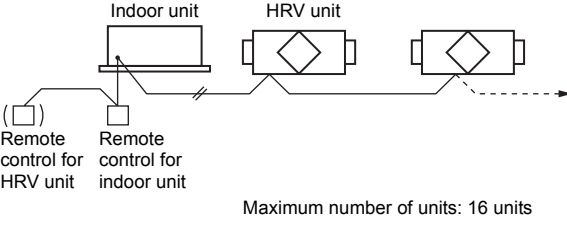
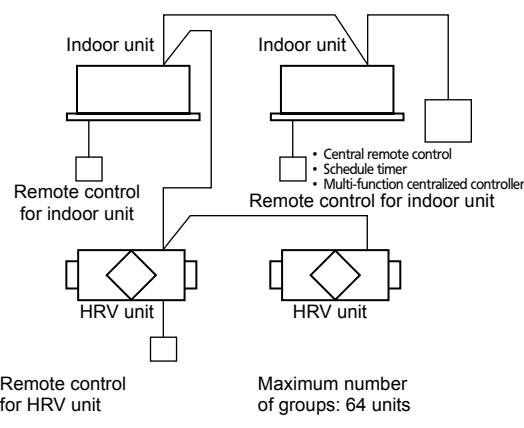
Control system	Purposes and applications	Description of system	Control system												
			Controller						Function						
			Central remote control	Unified On / Off controller	Schedule timer	Remote control for HRV unit	Remote controller for indoor unit	Operation / Stop	Ventilation mode changeover		Air flow rate changeover (High / Low)	Air flow rate mode changeover (normal mode / fresh-up mode)	Precool / preheat operation	Malfunction display	
Independent	<ul style="list-style-type: none"> Basic method to operate HRV unit (Operation by exclusive remote control for HRV unit) 					○	○	○	○	○	○	○	○	○	○
Interlocked operation	<ul style="list-style-type: none"> Interlocked operation with indoor unit by remote control for indoor unit The HRV unit can also be operated independently by the remote control for indoor unit, even if indoor unit is not in operation. The HRV unit cannot be operated independently when the duct is connected directly to the indoor unit. 					○*1	○	○	○	Initial setting required		○*2	○	○	
Centralized control	<ul style="list-style-type: none"> [Unified On / Off controller] A maximum of 16 groups can be controlled of "On / Off" by one unified On / Off controller. (Note) Up to 4 unified ON / OFF controllers can be installed in one system. [Schedule timer] One schedule timer can control the weekly schedule of up to 128 units. [Central remote control] Up to 64 groups of the units can be controlled individually by one central remote control. 		○	○	○	○	○	○	○	(Only when remote control for HRV unit is used) ○		(Initial setting required when remote control for HRV unit is not used) ○	○	○	

(HC0018)

1. A remote control for HRV unit can be connected as the 2nd remote control. In addition to air volume control, selection of ventilation mode and Fresh up mode is available.
2. In case of installing Indoor unit remote control only, initial setting is required for the setting of above function. However, in case of installing both indoor unit remote control and HRV unit remote control, initial setting is not required.

9 Control System

9 - 2 Basic patterns

9-2-1 List of control system

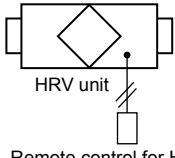
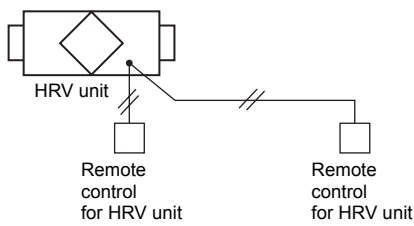
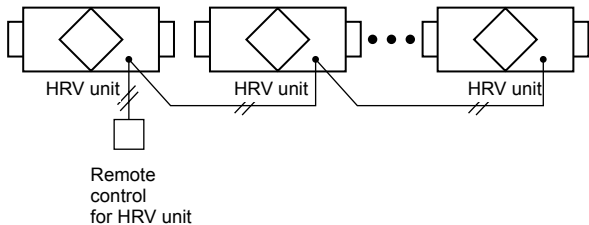
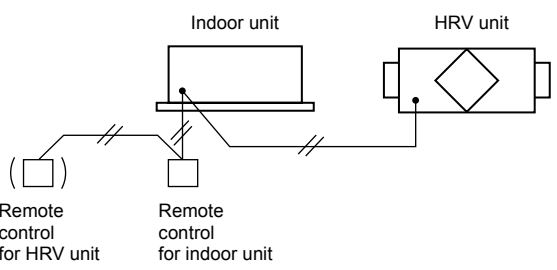
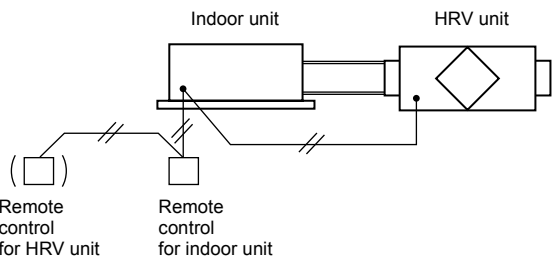
Control system	Purposes and applications	Description of system	Optional accessories required
Independent system	<p>Operation by main switch</p> <ul style="list-style-type: none"> Basic method to operate HRV unit The remote control for HRV unit is installed on each HRV unit for its operation. 	 <p>HRV unit</p> <p>Remote control for HRV unit</p>	BRC301B61 Liquid crystal remote control
	<p>Control with two remote controls</p> <ul style="list-style-type: none"> The HRV is operable from a place near the unit or a remote place and the selected control is indicated in the display. (Priority is on the last selection) 	 <p>HRV unit</p> <p>Remote control for HRV unit</p> <p>Remote control for HRV unit</p>	BRC301B61 Liquid crystal remote control
	<p>Group control</p> <ul style="list-style-type: none"> Simultaneous control of multiple units installed in such as a spacious room is available. 	 <p>HRV unit</p> <p>HRV unit</p> <p>HRV unit</p> <p>Remote control for HRV unit</p>	BRC301B61 Liquid crystal remote control
Interlocked operation system with VRV systems and SkyAir series	<p>Single-group interlocked operation</p> <ul style="list-style-type: none"> The HRV unit operates whenever the indoor unit is in operation, and can also be operated independently by the remote control for indoor unit, even if the indoor unit is not in operation. 	 <p>Indoor unit</p> <p>HRV unit</p> <p>Remote control for HRV unit</p> <p>Remote control for indoor unit</p>	_____
	<p>Direct duct connection system</p> <ul style="list-style-type: none"> Within the same group, the remote control for indoor unit can control the operation of both the indoor unit and HRV unit connected by duct. 	 <p>Indoor unit</p> <p>HRV unit</p> <p>Remote control for HRV unit</p> <p>Remote control for indoor unit</p>	_____

9 Control System

9 - 2 Basic patterns

	Function	Nos. of the unit controlled and length of wiring	Cautions	page
	<p>BRC301B61</p> <ul style="list-style-type: none"> • ON / OFF • Ventilation mode (Auto / Heat Exchange / Bypass) • Ventilating rate (High / Low) • Fresh up mode (On / Off) 	<ul style="list-style-type: none"> • One remote control operates each HRV unit. • Remote control wiring can be extended up to 500 m maximum. 	<ul style="list-style-type: none"> • The wire for remote control is not included as standard accessories and should be arranged locally. • By connecting the adapter PCB, the operation signal can be taken out remotely. • "Fresh-up operation" is possible by external input. • The group control is not possible by the remote control for HRV unit. 	114
	<p>BRC301B61</p> <ul style="list-style-type: none"> • ON / OFF • Ventilation mode (Auto / Heat Exchange / Bypass) • Ventilating rate (High / Low) • Fresh up mode (On / Off) • Timer setting (On / Off) • Indication of filter cleaning signal • Digital indication of malfunction 	<ul style="list-style-type: none"> • Control of one HRV with two remote controls • The maximum allowable total length of remote control wiring is 500 m. 	<ul style="list-style-type: none"> • Same as operation from local place. • It is necessary to set the Master / Slave changeover switch in the remote controller. • Two remote control operation is not available with simple remote control. 	115
		<ul style="list-style-type: none"> • Up to 16 HRV units can be controlled with one liquid crystal remote control. • The maximum total length of remote control wiring is 500 m. • Control with two remote control is available. 	<ul style="list-style-type: none"> • Same as operation from local place. • Group control is not available with a simple remote control. • All the settings of HRVs in the same group are the same (However, it is possible to fix the individual setting by each unit) 	115
	<ul style="list-style-type: none"> • The HRV unit operates whenever the indoor unit is in operation. • Precool / preheat operation is also possible. • Various settings are available by adding the HRV remote controllers. 	<ul style="list-style-type: none"> • A maximum of 16 units of indoor unit and HRV unit can be controlled by the remote controller for indoor unit. (if they are in the same group) • Remote control wiring can be extended up to 500 m maximum. 	<p>_____</p>	116
		<ul style="list-style-type: none"> • A maximum of 16 units of indoor unit and HRV unit can be controlled the operation by the remote control for indoor unit. • Remote control wiring can be extended up to 500 m maximum. 	<ul style="list-style-type: none"> • Make sure to set "ON" for direct ducting setting. • The HRV cannot be operated independently to prevent the dust, when the indoor unit is not in operation. However, if the fan of indoor unit is in operation, the HRV unit can be operated independently. 	116

(HC0019)

9 Control System

9 - 2 Basic patterns

Control system	Purposes and applications	Description of system	Optional accessories required
Interlocked operation system with VRV systems and SkyAir series Interlocked operation with 2 or more groups	<ul style="list-style-type: none"> When the HRV unit is interlocked to 2 or more groups of indoor units. The HRV unit operates if one of indoor unit in the groups is in operation. The HRV unit can also be operated independently by remote control for indoor unit, even if the indoor unit is not in operation. 	<p style="text-align: center;">Central transmission line</p> <p style="text-align: center;">Indoor unit Indoor unit HRV unit</p> <p style="text-align: center;">Remote controller for indoor unit Remote controller for indoor unit Adapter PCB for remote control</p> <p style="text-align: center;">Remote controller for indoor unit</p>	KRP2A61 ♦ Adapter PCB for remote control (One adapter PCB should be installed in either the HRV unit or the indoor unit.)
Centralized control system Collective / Individual control	<p>[Unified On / Off Controller]</p> <ul style="list-style-type: none"> A maximum of 16 groups can be controlled of "On / Off" by one controller, and up to four controllers can be installed in one system. <p>[Schedule Timer]</p> <ul style="list-style-type: none"> One schedule timer can control the weekly schedule of up to 128 units. <p>[Adapter PCB for remote control]</p> <ul style="list-style-type: none"> One adapter PCB can control up to 64 groups collectively. 	<p style="text-align: center;">Indoor unit HRV unit Unified On / Off controller or Schedule timer or Adapter PCB for remote control</p> <p style="text-align: center;">Remote control for indoor unit Remote control for HRV unit</p> <p style="text-align: center;">Indoor unit HRV unit</p> <p style="text-align: center;">Remote control for indoor unit</p>	DCS301B61 ♦ Unified On / Off Controller (up to 4 controllers) DST301B61 ♦ Schedule timer KRP2A61 ♦ Adapter PCB for remote control (not possible to use together with other central control) * One of the above control should be installed in indoor unit. (However, only KRP2A61 can also be installed in HRV unit.)
Centralized control system Zone control system	<ul style="list-style-type: none"> The Central remote controller can control the zone operation of the several groups of the units collectively. Central remote controller can control the independent operation of HRV unit in each zone. 	<p style="text-align: center;">Zone 1 Zone 2</p> <p style="text-align: center;">Indoor unit HRV unit HRV unit</p> <p style="text-align: center;">Remote control for indoor unit Remote control for HRV unit Remote control for HRV unit</p> <p style="text-align: center;">Remote control for indoor unit</p> <p style="text-align: center;">Central remote control</p>	DCS302B61 ♦ Central remote control

9 Control System

9 - 2 Basic patterns

Function	Nos. of the unit controlled and length of wiring	Cautions	page
<ul style="list-style-type: none"> The HRV unit operates of one of the indoor units connected to the central control transmission line is in operation. The various setting for the operation of HRV unit should be set by the remote control for the indoor unit. 	<ul style="list-style-type: none"> A maximum of 64 groups of the units can be controlled. The central control transmission line can be extended up to 1000 m maximum. 	<ul style="list-style-type: none"> No direct duct connection is possible. Set "ON" for collective zone interlock setting. 	117
<p>Collective / Individual operation [The unified On / Off control]</p> <ul style="list-style-type: none"> Each group can be controlled of "On / Off" individually. Each 16 groups can be controlled "On / Off" collectively. The power supply terminal for the schedule timer is provided. <p>[The schedule timer]</p> <ul style="list-style-type: none"> The schedule timer can control collectively the operation "ON / OFF" twice a day by weekly. Back-up power supply for 48 hours is provided, when the power failure is occurred. <p>[Adapter PCB for remote control]</p> <ul style="list-style-type: none"> The HRV units can be controlled "On / Off" collectively by external input. 	<ul style="list-style-type: none"> A maximum of 64 groups connected by the central transmission line can be controlled. The central transmission line can be extended up to 1000 m maximum. 	<ul style="list-style-type: none"> When you use the central controller, no direct duct connection is possible. <p>[The unified On / Off control]</p> <ul style="list-style-type: none"> Each group should be set the group number. (It cannot be set by the remote control for HRV unit.) The power must be supplied. <p>[The schedule timer]</p> <ul style="list-style-type: none"> When you use the schedule timer alone, it is necessary to supply the power of DC16V, which can be supplied from the printed circuit board of the unit. (from CN11 in case of HRV unit) <p>[Adapter PCB for remote control]</p> <ul style="list-style-type: none"> The adapter PCB for remote control cannot be used with other central controller. (It can be installed in the either indoor unit or HRV unit.) Only KRP2A61 can be installed in the HRV unit. (KRP2A2.A3 cannot be installed in the HRV unit because of their size.) 	118
<p>The interlocked operation [Multi function centralized controller]</p> <ul style="list-style-type: none"> It can control the operation "On / Off" individually or collectively. The several group of the units can be controlled collectively by zone. It can control the interlocked operation of the indoor units and the HRV units in the same zone. The electrical terminal for the schedule timer is provided. 	<ul style="list-style-type: none"> A maximum of 64 groups connected by the centralized transmission line can be controlled. The central transmission line can be extended up to 1000 m maximum. 	<ul style="list-style-type: none"> The initial setting by remote control for indoor unit is needed. (The collective zone interlock setting should be "On".) However, if there is no indoor unit in the same zone (only HRV units), the initial setting is not required. When you use the central transmission line, no direct duct connection is possible. <p>[Multi function central controller]</p> <ul style="list-style-type: none"> Each group should be set the group number for central control. (It cannot be set by the remote controller for HRV unit.) The power supply is needed. 	119

(HC0020)

9 Control System

9 - 2 Basic patterns

9-2-2 Independent system

Operation by main switch

Purposes and functions

- Basic method to operate HRV unit
The remote control for HRV unit is installed on each HRV unit for its operation.

[When you use remote control for HRV unit]

Cautions

1. The remote control for HRV unit should be connected to the terminal no. P1 and P2.
2. The remote control wiring should be arranged locally.
3. The operation by two remote controls or the group control is not possible.
4. The initial setting cannot be done by the remote control for HRV unit, which has to be set by the remote control for indoor unit.

Example of control wiring

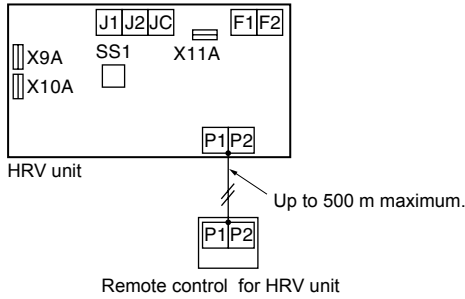

(HC0021)

Switch setting of HRV unit

- No change is required (as per factory setting)

Optional accessories required

- Remote control for HRV unit BRC301B61

Information

1. If you increase the air flow rate from “High” to “Ultra-High” by the remote control for HRV unit, it is necessary to have initial setting by the remote control for indoor unit or HRV unit.
2. The SS1 on the HRV unit is the selector switch of air flow rate.
When the remote control is not used, set the SS1 on the PC board to H.



(HC0022)

9 Control System

9 - 2 Basic patterns

9-2-2 Independent system

Control with two remote controls

Purpose and functions

- For control of one HRV unit (Also one group control is possible)
Sophisticated operation and indication output are possible from either local place or remote place by two liquid crystal remote controls.
- Either one of two liquid crystal remote controls can be used for all operations and indications.
(However, initial setting can only be carried out by the master remote control)

Point

- The wiring to the remote controls must be branched from the unit as shown in the diagram.
(Though the crossover between the master and slave remote controls is acceptable, the work to put two wires into the remote control takes time.)

Example of wiring for control

(HC0023)

Note

- The maximum allowable total length of wires to the remote control is 500 m.
- Simple remote controls cannot be used for control with two remote controls.

The following setting is required

- Either one of two remote controls must be set as a slave remote control.

Required optional accessories

- Liquid crystal remote control × 2
BRC301B61

Group control

Purpose and functions

- Simultaneous control of multiple HRV units (max. 16 units) is available (for application to such as a spacious room)
- All operation and individual setting can be carried out from one remote control.
- In case the liquid crystal indicates malfunction, the indication of HRV unit No. shows in the display.
(If another remote control is additionally installed, control with two remote controls is possible.)

Point

- No address setting is required because address is automatically set.
(The address is optionally allocated. The address No. can be confirmed by setting to service mode "Forced fan operation" and be checked whether the unit is in operation or not.)

Example of wiring for control

(HC0024)

Note

- The maximum allowable total length of wires to the remote control is 500 m.
- One liquid crystal remote control is always required.
- Simple remote controls cannot be used for control with two remote controls.

The following setting is required

- No setting is required. (product is to be just as it was when shipped from the factory)

Required optional accessories

- One set of liquid crystal remote control
BRC301B61

9 Control System

9 - 2 Basic patterns

9-2-3 The interlocked operation system

Single-group interlocked operation (Basic pattern)

Purposes and functions

- The remote control for indoor unit can control the interlocked operation with the HRV unit, and it can make an initial setting of the ventilation flow rate, the ventilation mode changeover and fresh-up operation. The HRV unit can independently be operated, even if the indoor unit is not in operation.

Note

- The remote control should be connected to the terminal no. P1 and P2, the same as the group control wiring of indoor units.
- Since this is two remote control system (for Indoor unit and HRV unit), the Master / Slave setting is required.

Remote control for	Setting
Indoor unit	Slave
HRV unit	Master

Example of control wiring

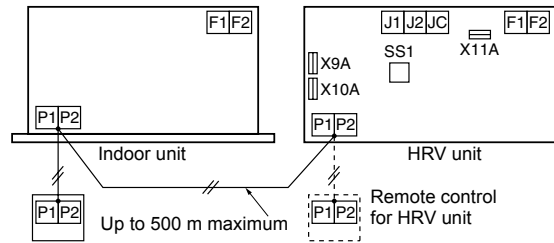

(HC0025)

Switch setting for HRV unit

- No change is required. (as per factory setting)

Optional accessories required

- None

Single-group interlocked operation (Direct duct connection)

Purposes and functions

- The operation of HRV unit is interlocked to the indoor unit connected by the duct, which has a fresh air intake.
- It can reduce the number of outlets for supply air.
- The HRV unit cannot be operated independently to prevent a reverse stream of fresh air to the suction side of the indoor unit, unless the fan of indoor is in operation.

Note

- The amount of fresh air to the indoor unit should be less than 20% of the total air volume of the indoor unit. (If the amount of fresh air is too much, the capacity of the indoor unit may reduce and the operating sound might be higher.)
- The HRV unit can be operated independently, if the fan of indoor unit is in operation.
- Since this is two remote control system (for Indoor unit and HRV unit), the Master / Slave setting is required.

Remote control for	Setting
Indoor unit	Slave
HRV unit	Master

Example of control wiring

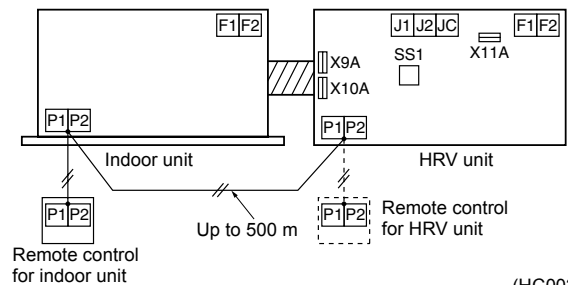

(HC0026)

Switch setting for HRV unit

The initial setting by the remote control for indoor unit Direct duct setting "ON" [17(27)-5-02]

Optional accessories required

- None

9 Control System

9 - 2 Basic patterns

9-2-3 The interlocked operation system

Interlocked operation with 2 or more group of VRV system

Purposes and functions

- When the HRV unit is interlocked to 2 or more group of indoor units, the HRV unit operates, if one of indoor unit in groups is in operation. The HRV unit can also be operated independently by remote control for indoor unit, even if the indoor unit is not in operation.

Cautions

- It is not necessary to set the group number for central control.
- One adapter PCB for remote control should be installed in the one of the unit connected to the central transmission line.

(When you install an adapter PCB for remote control in the indoor unit, select the applicable model number of Adapter PCB to be installed.)

Example of control wiring

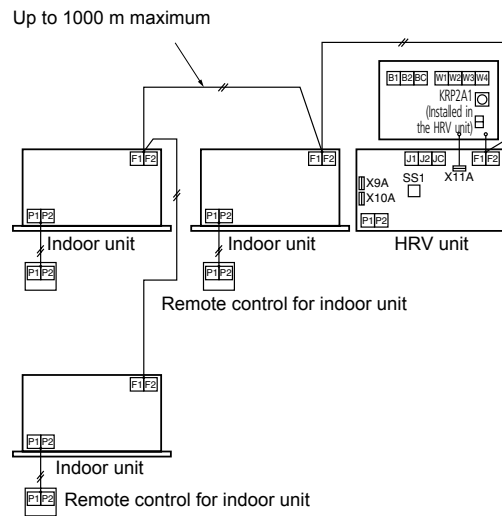

(HC0027)

Note:

The central transmission line can be extended up to 1000 m maximum.

Switch setting for HRV unit

The initial setting by the remote control for indoor unit or HRV unit.

Optional accessories required

- Adapter PCB for remote control: KRP2A61

9 Control System

9 - 2 Basic patterns

9-2-4 Centralized control system

Collective / individual control [Unified On / Off control DCS301B61]

Purposes and functions

- One control can control the operation of "ON / OFF" of 16 groups of the units collectively or individually.
Also up to 4 controls can be installed in one centralized transmission line (in one system), which enables to control up to 64 groups. (16 groups × 4 = 64 groups)
- The ventilation mode will be selected automatically.

Cautions

1. It is necessary to assign a central group number to each indoor unit and HRV unit.
2. The operation of HRV unit is not interlocked with the operation of indoor unit under this control system. If you like to have a interlocked operation, please consider other control system.

Switch setting for HRV unit

The initial setting is required by the remote control for indoor unit or HRV unit.

- No change is required (as per factory setting)

Optional accessories required

- Remote control (Only when you use) BRC301B61

Example of control wiring

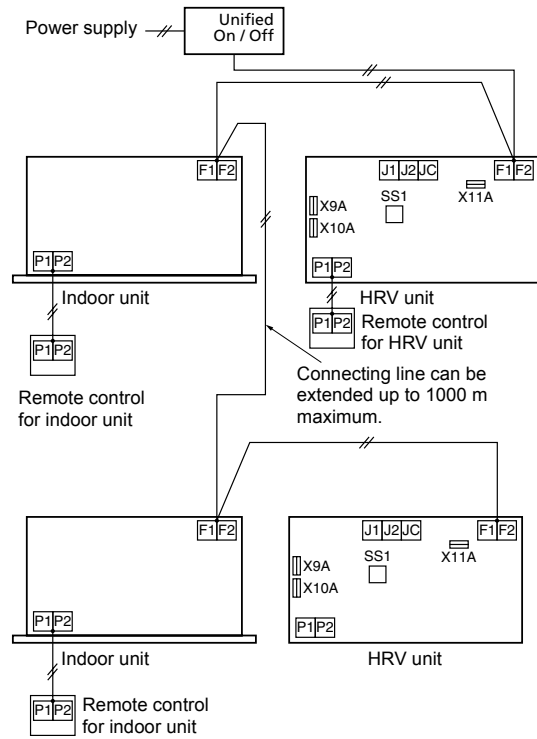

(HC0028)

9 Control System

9 - 2 Basic patterns

9-2-4 Centralized control system

Zone control system (Central remote control DCS302B61)

Purposes and functions

- A maximum of 64 groups can be controlled On / Off individually by one control. And also the central remote control can control the On / Off operation of the units in each zone collectively. (It also can control the interlocked operation as well as the independent operation within the same zone.)
- If the zone setting is not required, or if you like to operate the HRV unit whenever one of indoor unit of any group connected to the central transmission line is in operation, refer to the applied system.

Cautions

1. It is necessary to assign a central control group number.
2. If you operate the HRV unit interlocked to the operation of indoor unit, please set the same zone number. At that time, it is necessary to set the zone operation on the HRV unit.
3. It is not possible to operate On / Off from the remote control for the HRV unit in zone 1.
4. It is not necessary to set the zone operation mode in zone 2, which is already set at the factory.

Switch setting for HRV unit

The initial setting is required by the remote control for indoor unit or HRV unit.

- For zone 1 "ON" [17(27)-8-02]
- For zone 2 Factory set (No change is required)

Optional accessories required

- Remote control (Only when you use) BRC301B61

Example of control wiring

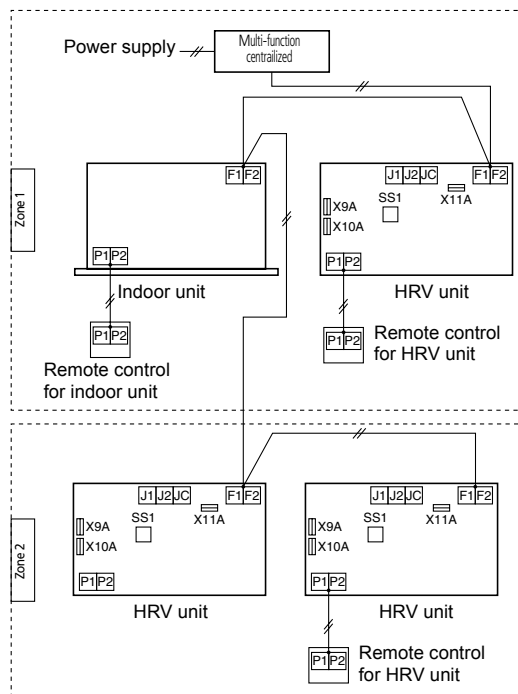

(HC0029)

9 Control System

9 - 3 Applicable patterns

9-3-1 Additional functions

Operation by power supply [HRV unit]

Purposes and functions

- The HRV unit is operated by "On / Off" of the main power breaker. This is possible only for the independent operation system. (When the main power is disconnected, the transmission error will be displayed if the HRV unit is interlocked to the indoor unit or controlled by the centralized control.)

Cautions

- Install insect control wire net on the air intake and exhaust openings. (If the power is disconnected when the damper is open, the damper remains open and the insects may get into the room.)
- When you install the remote control, it is possible to have normal operation after the electric power is supplied.

Example of control wiring

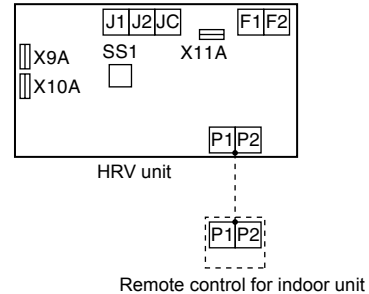

(HC0030)

Switch setting for HRV unit

The initial setting is required by the remote control for indoor unit. Power-on setting..... "ON" [18(28)-1-02]

Install the remote control for indoor unit for the initial setting. After completion of the initial setting, remove the remote control.

Optional accessories required

- None

Monitor of operation (KRP50-2) [HRV unit → operating pilot lamp (local supply)]

Purposes and functions

To monitor the operation of one HRV unit.

Example of control wiring

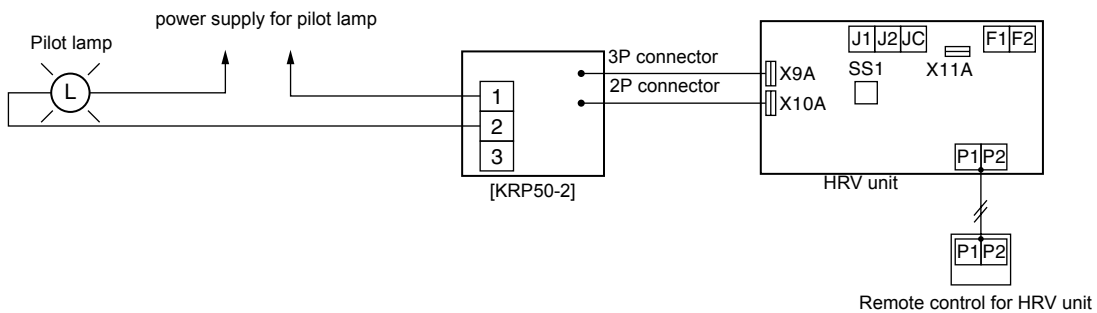

(HC0031)

Switch setting for HRV unit

- No change is required. (as per factory setting)

Optional accessories required

- Adapter PCB: KRP50-2

9 Control System

9 - 3 Applicable patterns

9-3-1 Additional functions

Fresh-up operation by external input [HRV unit]

Purposes and functions

When the operation is interlocked with the local ventilating fan (such as the one for toilet or kitchen), the HRV unit performs the over-supply operation to prevent the reverse flow of the odor. The flow rate of supply air becomes higher than that of exhaust air.

Example of control wiring

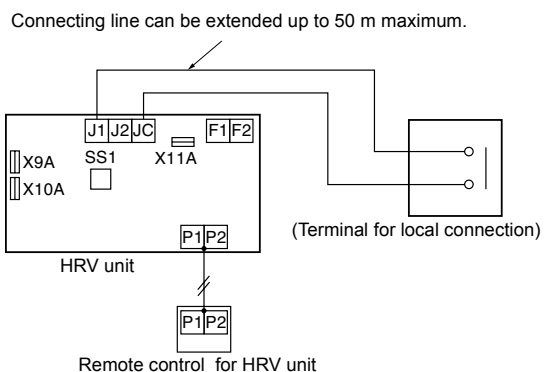

(HC0032)

- Local wiring

Operation of HRV unit	Terminal for local connection	Capacity of connecting terminal
Fresh-up	Short-circuit	No-voltage normally open contact for micro-current 16 V, 10 mA
Normal	Open circuit	

Note:

The connecting wiring between HRV unit and the terminal for local connection can be extended up to 50 m maximum.

Switch setting of HRV unit

- No change is required (factory setting)

Optional accessories required

- None

9 Control System

9 - 3 Applicable patterns

9-3-1 Additional functions

Precool / preheat operation

Purposes and functions

- The operation of HRV unit is delayed when the air conditioner begins operation.

Cautions

- The precool / preheat function is possible only when the operation of HRV unit is interlocked to one-group or two-group of indoor unit. (It will not function when the HRV unit is in independent operation.)
- You can select the preset time of 30 / 45 / 60 minutes for delayed operation at the time of initial setting. If this preset time is not sufficient, you can extend the preset time for further 30 / 60 / 90 minutes only the preheating function.
- Since this is two remote control system (for Indoor unit and HR unit), the Master / Slave setting is required.

Remote control for	Setting
Indoor unit	Slave
HRV unit	Master

Example of control wiring

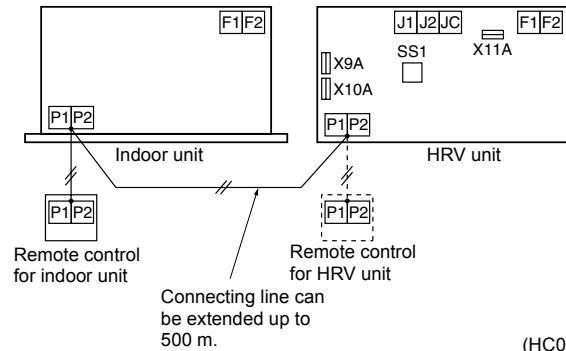

(HC0033)

Switch setting of the HRV unit

The initial setting by the remote control for the indoor unit.

- Precool / preheat On / Off setting "ON" [17(27)-2-02]
- Precool / preheat time setting "Time" [17(27)-3-*1]
- Preheat extra time setting "Time" [17(27)-9-*2]

*1 setting 01 for 30, 02 for 45 and 03 for 60 minutes.

*2 setting 01 for 0 (factory set), 02 for 30, 03 for 60 and 04 for 90 minutes.

Optional accessories required

- None

Remote control operation by input from outside

Purposes and functions

- The HRV unit can be controlled the operation of "On / Off" remotely by the signal from no-voltage normally open contact.

Cautions

- When the system is under group control, the input from outside controls the operation of "ON / OFF" collectively, if it is installed in the one of the unit.

Example of control wiring

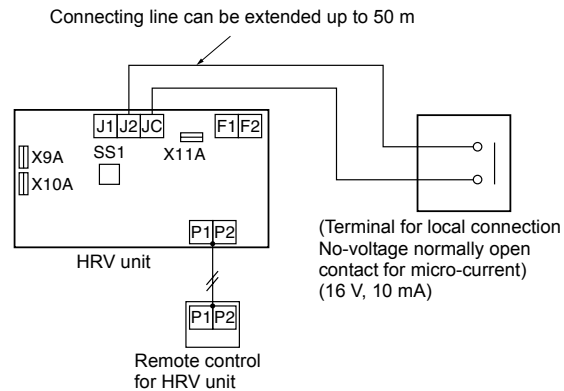

(HC0034)

Switch setting of HRV unit

- No change is required.

Optional accessories required

- None

9 Control System

9 - 3 Applicable patterns

9-3-2 To connect the remote control to the HRV unit

(Part 1) single-group interlocked operation

Purposes and functions
 When the HRV unit is interlocked to the single-group control system, the remote control for HRV unit will be connected to change the setting mode at the HRV unit side.

Cautions

1. It is not possible to set the "On / Off" and "timer" setting by the remote control for HRV unit. Also it is not possible to display the filter-sign and malfunction code neither on the remote control for indoor unit nor on the remote control for HRV unit.
2. Since this is two remote control system (for Indoor unit and HR unit), the Master / Slave setting is required.

Remote control for	Setting
Indoor unit	Slave
HRV unit	Master

Example of control wiring

(HC0033)

Switch setting of the HRV unit

- No change is required (as per factory setting)

Optional accessories required

- Remote control BRC301B61

(Part 2) Centralized control operation

Purposes and functions

- Beside the operation by central remote control, the remote control for HRV unit can change the ventilation mode setting, the ventilation air flow setting and etc.

Cautions

1. In case of Zone control, the operation / stop and the timer setting cannot be done by the remote control for the HRV unit. (The operation lamp blinks twice to indicate that the operation is not possible.)
2. The remote control for the HRV unit cannot set the group no. for centralized control. In this case, the remote control for the indoor unit has to be connected once for this setting.
3. It is not possible to have Precool / preheat time setting function.

Example of control wiring

(HC0035)

Switch setting of the HRV unit

Group no. setting for central control is required. It is necessary to set the group number for each unit connected to the central transmission line (terminal no. (F1) and (F2)). Initial setting is required by the remote control for indoor unit.

- In case of collective / individual control
 Collective zone interlock setting
 "OFF" (as per factory set)
- In case of zone control
 Collective zone interlock setting
 "ON" [17(27)-8-02]

Optional accessories required

- Remote control BRC301B61

9 Control System

9 - 3 Applicable patterns

9-3-3 Central control system (DCS302B61)

Collective / individual operation (Central remote control)

Purposes and functions

It is possible to have collective On / Off or individual On / Off without zone control (while setting the 64 zones). It is also possible to connect the unified On / Off control and etc.

Cautions

1. It is required the local setting of the group number for central control.
2. The HRV unit judges the ventilation mode, individually.

Example of control wiring

Central remote control

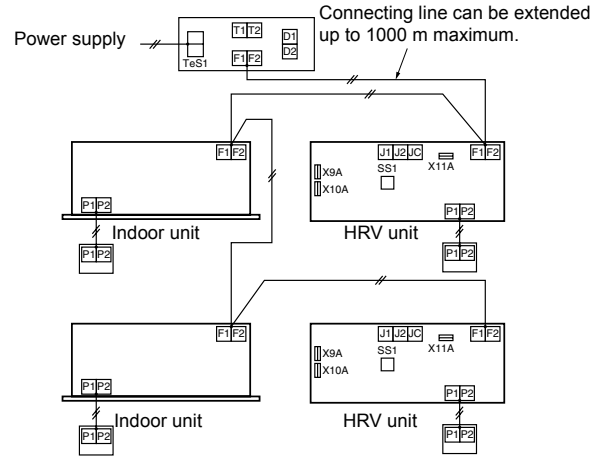

Switch setting of the HRV unit

The initial setting is required by the remote control for indoor unit.

- Collective zone interlock setting "OFF" (as per factory set)

Optional accessories required

- Central remote control DCS302B61

9 Control System

9 - 3 Applicable patterns

9-3-3 Central control system (DCS302B61)

Collective operation (Schedule timer DST301B61)

Purposes and functions

- A maximum of 128 units can be controlled the collective operation / stop by weekly schedule.

Cautions

1. The setting of group number for central control is not required.
2. The HRV unit judges the ventilation mode, individually.
3. The power supply for the schedule timer can be supplied from the PCB of the unit. (X18A for the indoor unit and X11A for the HRV unit)

Example of control wiring

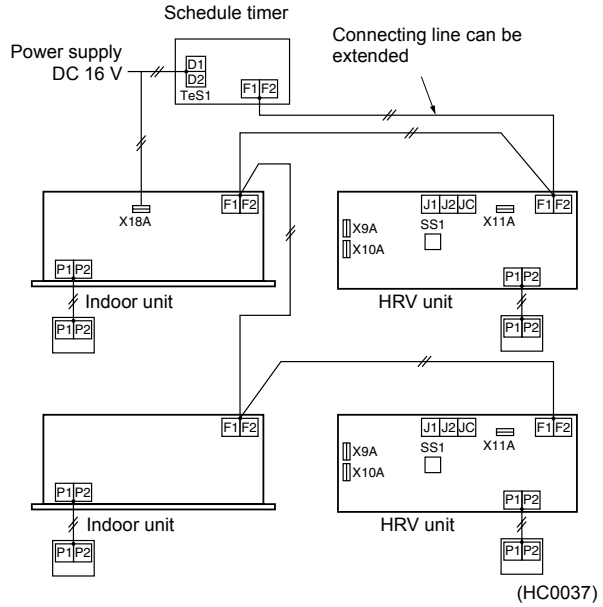

Switch setting of the HRV unit

The initial setting is required by the remote control for the indoor unit.

- Collective zone interlock setting“OFF” (Factory setting)

Optional accessories required

- Schedule timer DST301B61

9 Control System

9 - 3 Applicable patterns

9-3-3 Central control system (DCS302B61)

Collective operation [Adapter PCB for remote control KRP2A Series]

Purposes and functions

A maximum of 64 groups can be controlled the operation of "ON / OFF" collectively. (For the individual control, use the central remote control or the unified On / Off control.)

Cautions

1. Adapter PCB can be installed in any unit connected to the central transmission line.
2. It cannot be used with other central control.
3. The setting of group number is not required.
4. The HRV unit judges the ventilation mode, individually.

Example control wiring

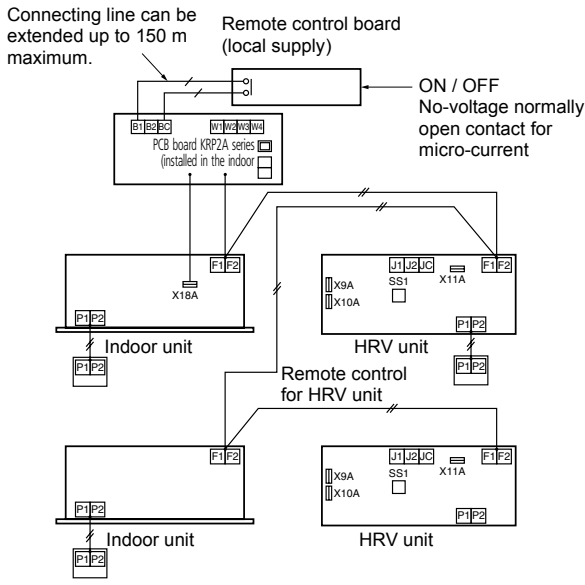

Switch setting of the HRV unit

The initial setting is required by the remote control for the indoor unit or HRV unit.

- Collective zone interlock setting
....."OFF" (as per factory setting)
 - The setting of switch on the PCB
 - Voltage / no-voltage changeover switch(SS1)
....."no-voltage"
- * Remote control mode changeover switch (RS1) should be selected.

Optional accessories required

Adapter PCB for remote control KRP2A61

9 Control System

9 - 3 Applicable patterns

9-3-3 Central control system (DCS302B61)

Multi function central control + Unified On / Off Control

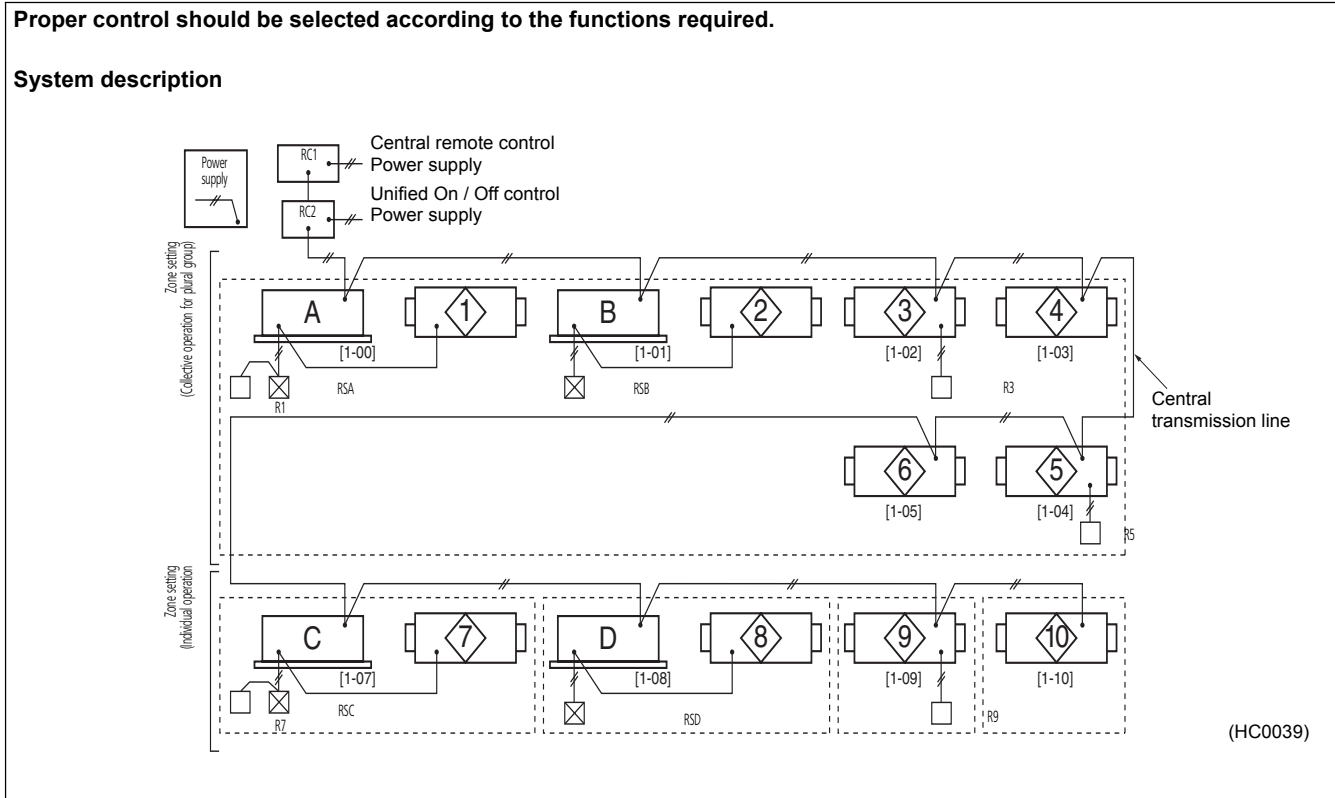

Unit No.	Setting					Operation display functions (○ means possible)																Choose condition	
	Zone setting		Interlocked zone control		Group number setting for central control Required (●) Not Required	Operation / stop				Independent ventilation Operation/stop				Ventilation air flow Ventilation mode Fresh-up				Filter-sign Malfunction code				HRV unit side	
	Collective	Individual	On	Off		RC1	RC2	RSA - D	R1 - 9	RC1	RC2	RSA - D	R1 - 9	RC1	RC2	RSA - D	R1 - 9	RC1	RC2	RSA - D	R1 - 9	Interlocked operation with Energy saving	*4 Total evaluation
①	●			●	Not required (Setting required only for ① ②)	Collective by zone	Linked to A/B	○	—	—	Linked to A/B	○	—	—	—	○	—	—	—	○	—	○	AA
②	●			●				○	—	—		○	—	—	—	—	—	—	—	—	—	—	—
③	●		●	●	—		○	—	—	—	○	—	—	—	—	○	○	—	—	○	—	○	AA
④	●		●	●	(Connection required, ● when setting)		—	○	—	—	—	○	—	—	—	—	○	—	—	—	—	○	BB
⑤	●			●	○		—	○	—	—	○	—	○	—	—	○	○	—	—	○	—	—	CC
⑥	●			●	(Connection required, ● when setting)		○	—	—	—	○	—	—	—	—	○	—	—	—	—	—	—	DD
⑦		●		●	Not required (Setting required only for ⑦ ⑧)		Linked to C/D	○	—	—	Linked to C/D	○	—	—	—	○	—	—	—	○	—	○	AA
⑧		●		●				○	—	—		○	—	—	—	—	—	—	—	—	—	—	—
⑨		●		●	○		○	—	○	○	○	—	○	—	—	○	○	—	—	○	—	—	*5 CC
⑩		●		●	(Connection required, ● when setting)		○	○	—	○	○	—	—	—	—	○	—	—	—	—	—	—	*5 DD

*1. Independent operation for ventilation is possible, if collective zone interlock setting is "ON" with the indoor unit in the same zone.

*2. It is possible by the initial setting.

*3. Display of malfunction code only.

*4. The meaning of total evaluation

AA: Interlocked operation with energy saving and changeable of Ventilation mode / Air flow rate

BB: Interlocked operation with energy saving and no changeable of Ventilation mode / Air flow rate

CC: No interlocked operation with energy saving and changeable of Ventilation mode / Air flow rate

DD: No interlocked operation with energy saving and no changeable of Ventilation mode / Air flow rate

*5. Interlocked operation setting must not be done for individual zone. (Because there is no unit to combine in zone except 1 unit.)

9 Control System

9 - 3 Applicable patterns

9-3-4 Examples of mistakes in wiring and system designing

It is necessary to install the remote control for the transmission line.

<Part 1>

- When you connect the transmission line for the remote control, the remote control should be installed on the transmission line.

Example of control wiring

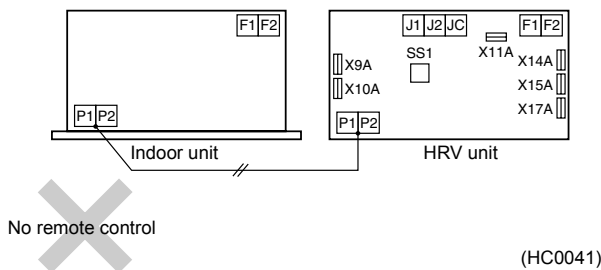

Reason

Because the signal through the transmission line is originated from the remote control, there is no transmission signal to operate the units, if the remote control is not installed.

The centralized transmission line should be connected to the indoor unit.

<Part 2>

- If the HRV unit is interlocked to the centralized control, the central transmission line should be connected to the terminal no. F1 and F2 of indoor unit.

Example of control wiring

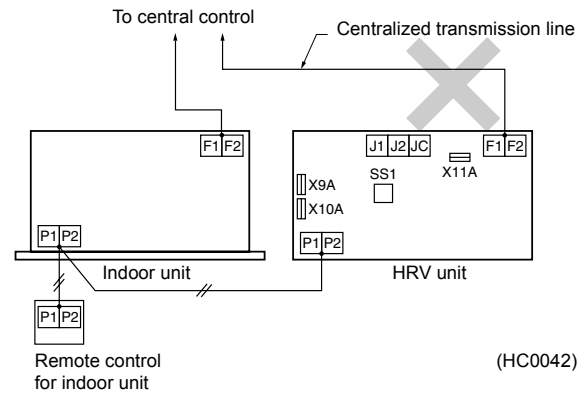

Reason

The information from the indoor unit cannot be transmitted to the central control through the HRV unit. And also the information from the central control cannot be transmitted to the indoor unit through the HRV unit.

9 Control System

9 - 3 Applicable patterns

9-3-4 Examples of mistakes in wiring and system designing

Setting of Remote Control for HRV unit

List of Settings

Mode no.		Setting switch no.	Description of Setting	Setting position no. (Caution *1.)					
Group settings	Individual settings			01	02	03	04	05	06
17	27	0	Filter cleaning time setting	Approx. 2500 hours	Approx. 1250 hours	No counting	—	—	—
		2	Precool / preheat on / off setting	Off	On	—	—	—	—
		3	Precool / preheat time setting	30 min	45 min	60 min	—	—	—
		4	Fan speed initial setting	Normal	Ultra high	—	—	—	—
		5	Yes / No setting for direct duct Connection with VRV system (Fan operation selection for heater thermo OFF)	No duct (Air flow setting)	With duct (fan off)	—	—	—	—
				—	—	No duct		With duct	
		7	Centralized / individual setting	Centralized	Individual	—	—	—	—
		8	Centralized zone interlock setting	No	Yes	Priority on Operation	—	—	—
9	Preheat time extension setting	0 min	30 min	60 min	90 min	—	—		
18	28	0	External signal JC / J2	Last command	Priority on external input	—	—	—	—
		1	Setting for direct Power ON	Off	On	—	—	—	—
		2	Auto restart setting	Off	On	—	—	—	—
		4	Indication of ventilation mode / Not indication	Indication	No Indication	—	—	—	—
		7	Fresh up air supply / exhaust setting	No Indication	No Indication	Indication	Indication	—	—
				Supply	Exhaust	Supply	Exhaust	—	—
		8	External input terminal function selection (between J1 and JC)	Fresh-up	Overall alarm	Overall malfunction	Forced off	Fan forced off	Air flow Increase
9	KRP50-2 output switching selection (between 1 and 3)	Humidify	Abnormal	Fan on / off	—	—	—		
19	29	0	Ventilation air flow setting	Low	Low	Low	Low	High	High
		2	Ventilation mode setting	Automatic	Exchange	By pass	—	—	—
		3	“Fresh Up” on / off setting	Off	On	—	—	—	—
		8	Electric heater setting	No delay	No delay	On, off delay	On, off delay	—	—

Caution

- The setting positions are set at “01” at the factory.
The ventilation air flow, however, is set at “05” (medium) in the HRV unit. When lower or higher setting is desired, change the setting after installation.

Group number setting for centralized control

- Mode no. 00: Group control
- Mode no. 30: Individual control

* Regarding the setting procedure, refer to the section “Group number setting for centralized control” in the operating manual of either the on / off control or the central control.

9 Control System

9 - 4 Functions of Printed Circuit Board

9-4-1 Layout of switches on Printed Circuit Board

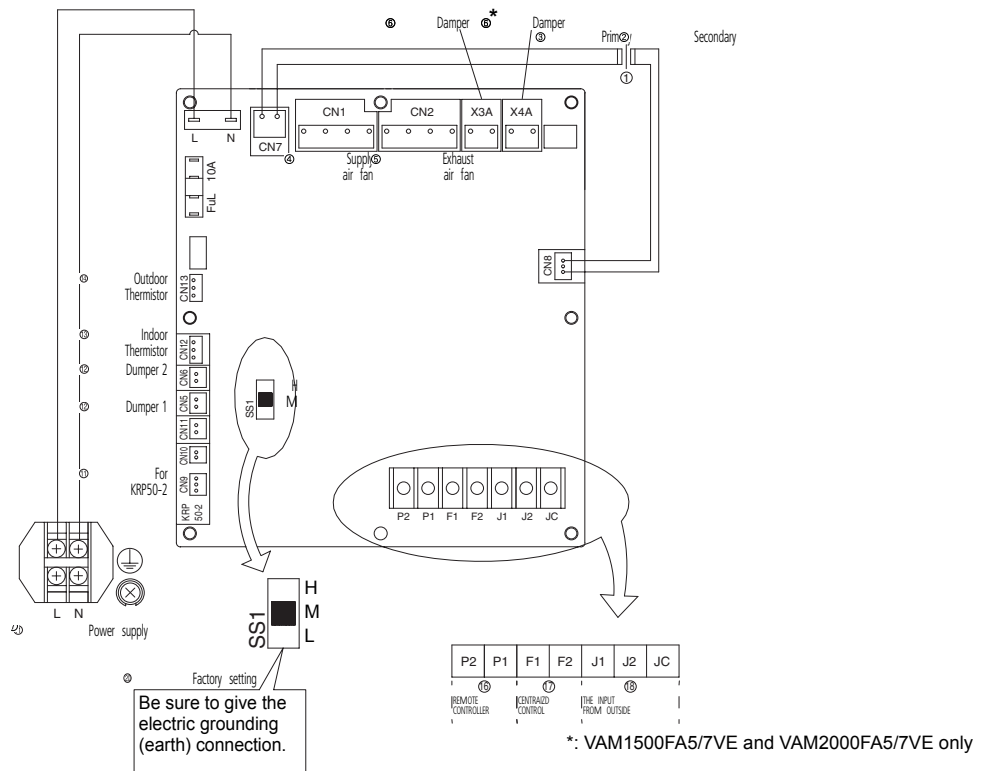

(HC0110)
3P034928-2B

9-4-2 Function of main connection terminal

	Terminal No.	Contents of function
Power supply	L N TeS1	Single phase 220 - 240 V Power supply and earth terminal
Remote control	P1 P2	Connection terminal for remote controller for HRV unit. This terminal is used to receive information of the indoor unit for interlocked operation.
Centralized control	F1 F2	This terminal is used to receive information when centralized controller is connected.
Input from outside	J1 J2 JC	Between terminal no. (J1) ~ (JC) Used for "fresh up operation" by external input. Between terminal no. (J2) ~ (JC) Used for Operation / Stop by external input.

(HC0043)

9 Control System

9 - 5 Fan operation setting

Interlocked operation system	With remote control for indoor unit	Initial setting by the remote control for indoor unit			Fan operation					
		Ventilation air flow setting	Fan speed	Fresh-up operation	Fresh-up Supply air setting		Fresh-up Exhaust air setting			
					Supply side	Exhaust side	Supply side	Exhaust side		
Interlocked operation system	With remote control for indoor unit	Normal	Low	Off	Low	Low	Low	Low		
				On	High	Low	Low	High		
			High	Off	High	High	High	High		
		Ultra-high	Low	On	Ultra-high	High	High	Ultra-high		
				Off	Low	Low	Low	Low		
			High	On	High	Low	Low	High		
Independent system	With remote control for HRV unit	Normal	Low	Open	Low	Low	Low	Low		
				Short-circuit	High	Low	Low	High		
		Ultra-high	Low	Open	Low	Low	Low	Low		
				Short-circuit	High	Low	Low	High		
		Centralized control system	With remote control for HRV unit	Ultra-high	High	Open	Ultra-high	Ultra-high	Ultra-high	Ultra-high
						Short-circuit	Ultra-high	High	High	Ultra-high

(HC0044)

9 - 6 Pre -Operation flowchart

system		Operating command		Operation command
		By the remote control for indoor unit	By the central control	
Interlocked operation	Interlocked control interlocked to single-group and two-groups	○	—	Only for cooling and heating mode

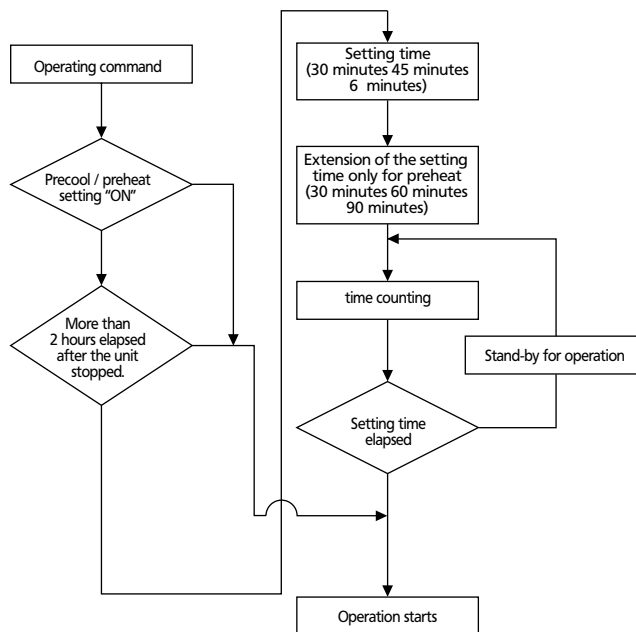

(HC0045)

9 Control System

9 - 7 Operation mode change over

1. In case of cooling operation

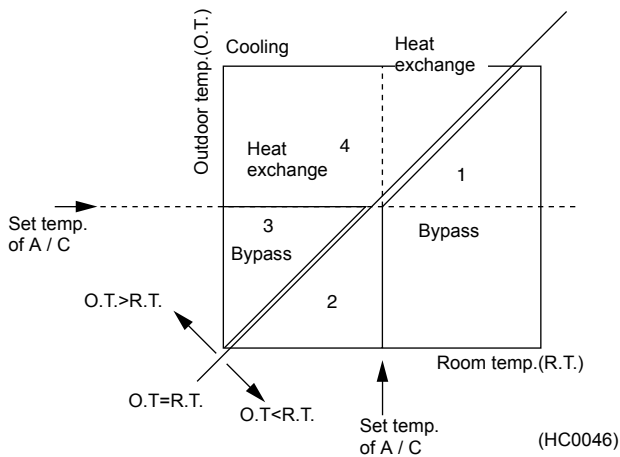

- 1 zone: Free cooling (cooling by outdoor air) in bypass mode.*
 - 2 zone: Room temperature to be achieved to set temperature by heat exchange mode.
 - 3 zone: Room temperature to be achieved to set temperature in bypass mode.*
 - 4 zone: Fresh air supply is cooled down by indoor air in heat exchange mode (energy saving).
- * The air cannot be supplied at the same temperature as the outdoor air because it is partly heat-exchanged.

2. In case of heating operation

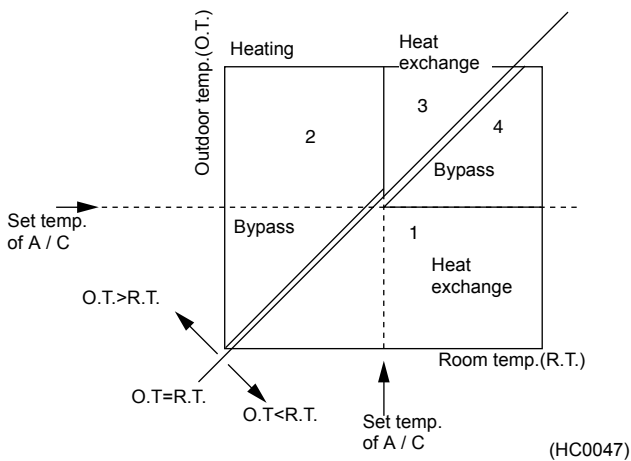

- 1 zone: Fresh air supply is heated up by indoor air in heat exchange mode (energy saving).
 - 2 zone: Free heating (heating by outdoor air) in bypass mode.*
 - 3 zone: Room temperature to be achieved to set temperature by heat exchange.
 - 4 zone: Room temperature to be achieved to set temperature by bypass mode.*
- * The air cannot be supplied at the same temperature as the outdoor air because it is partly heat-exchanged.

3. In case of fan operation only

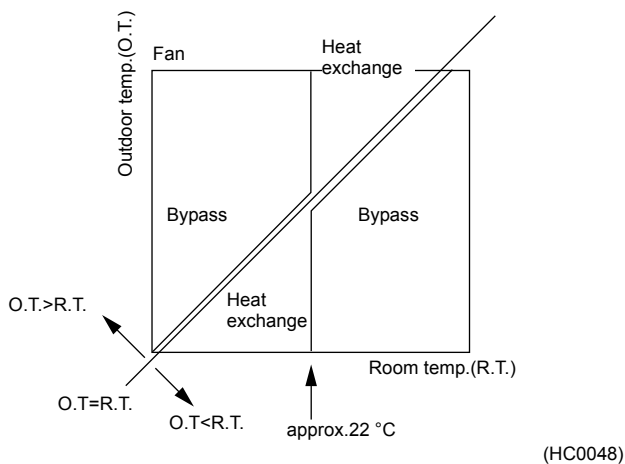

Ventilation mode is individually determined by the original formula of HRV with the temperature sensors.

10 Installation

10 - 1 Reducing operating sound

The air suction and discharge grille may give out operating sound higher by 8 to 11 phons than of the HRV units body. When installing this unit in a quiet place, take measures to reduce operating sound.

10-1-1 Points for reducing operating sound

- Operating sound heard from the air discharge outlet can be reduced just by applying sound-insulating material to the SA (indoor air supply) duct.

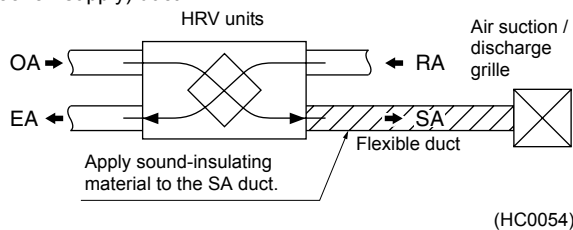

- Operating sound can be reduced more effectively by applying sound-insulating material to a portion of the SA duct near the unit body than that near the air suction / discharge grille.

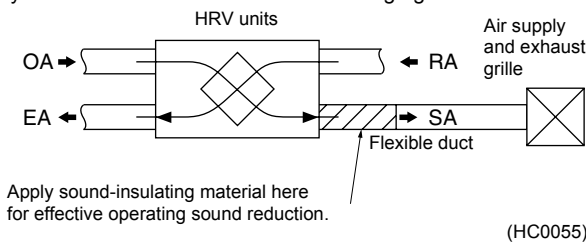

10-1-2 Taking measures to reduce operating sound heard from attic-installed equipment and air ducts.

- When installing large air volume models (650 m³ / h or more), avoid the following wherever possible if it is expected to be necessary to apply sound-insulating material to them. (Fig.1)

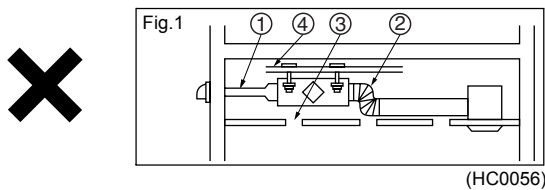

- Making the duct diameter extremely small (Example: φ 250 → φ 150, φ 200 → φ 100)
- Making the duct extremely bent using bellows (in particular, connecting bellows to the air discharge outlet of the unit body)
- Making opening holes on the ceiling
- Hanging the unit on a material which does not have enough hanging strength
See "Precautions for installing and handling the unit" on pages 77 and 87.

- Take the following sound reduction measures. (Fig.2)

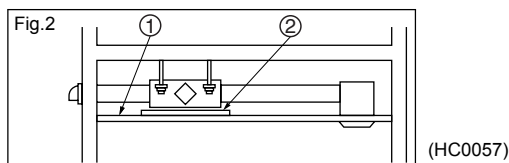

- Use a sound-insulating (low-permeability-to-sound) ceiling.

Note:

Some sound-insulating ceilings are not very effective in reducing low-frequency element of the operating sound.

- Place a sound-reducing material under the source of the operating sound.

Note:

When using a sound-insulating sheet, it is necessary to have the entire body of the unit covered with it. Note, however, that some models do not allow the use of a sound-insulating sheet because it may badly affect the ventilation of their radiation heat.

10-1-3 Reducing operating sound heard from the air discharge outlet (suction inlet)

- Use the following recommended optional accessories to reduce operating sound heard from attic-installed duct type models. (Fig.3)

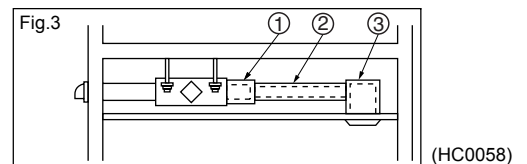

- Sound-eliminating box (Silencer)
- Flexible duct
- Sound-eliminating air suction / discharge grille

- If the above accessories do not give satisfactory effect or when an attic-installed cassette type model is used, take the following measure.

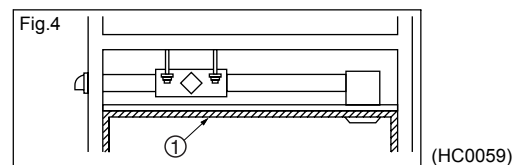

- Apply a sound-absorbing material to the interior of the room.

- To reduce the air flow sound heard from the air discharge outlet (suction inlet) of an attic-installed duct type model, use a small diameter flexible duct, which excels in sound absorptivity, for greater sound reduction effect.

- Branched duct (for letting air flow through two ducts to slow down its speed before it reaches the air discharge outlets (suction inlets))

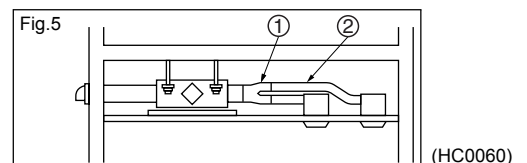

- Flexible duct

- Installation of the unit with the source of its operating sound located at a corner of a room will be a partially effective sound reduction measure; it will keep persons in the center of the room free from the annoying operating sound, with those in the corner of the room kept annoyed by the operating sound. To avoid this, try to find the best installation place from which the operating sound is least heard by everyone in the room.

10 Installation

10 - 1 Reducing operating sound

10-1-4 Effect of remedy for sound

Caution

1. Be sure to connect a flexible duct (2 m) to an outlet of the main body in the indoor air supply side.
2. Do not connect a spiral duct and an aluminium bellows directly to the outlet of the main body.
*A silencer is effective especially when using the flexible duct at the same time.

10-1-5 General comparison of the effect (① → ⑥ in more effective order)

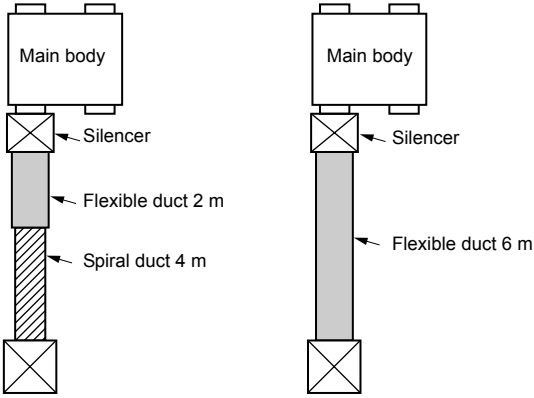
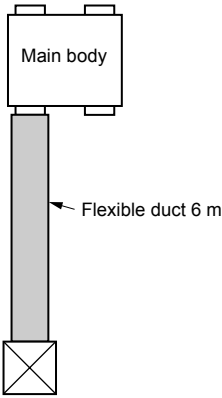
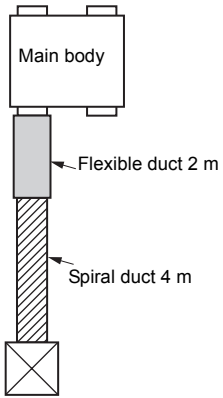
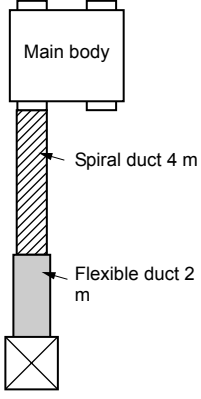
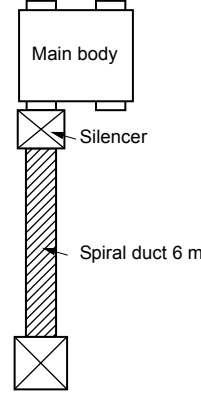
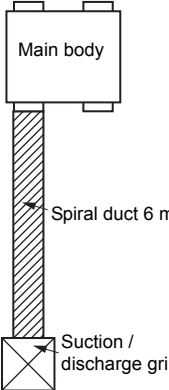
<p>① Mounting a silencer + flexible duct 2 m long Mounting a silencer + flexible duct 6 m long</p>	<p>② Mounting a flexible duct 6 m long</p>	<p>③ Mounting a flexible duct 2 m long to the main body</p>							
 <p>(Effect of a remedy for noise does not change even for over 2 m long duct)</p>									
<p>④ Mounting a flexible duct 2 m long to an air suction discharge grill</p>	<p>⑤ Mounting a silencer</p>	<p>⑥ Spiral duct 6 m No measures taken</p>							
			(dB)	①	②	③	④	⑤	⑥

(HC0061)

Note:

Measure the noise at 1.5 m below the air supply grille. Operating noise conforms to JIS standard and the value is converted in terms of the anechoic chamber.

10-1-6 Nameplate for note

“Notes for duct work” is written on the HRV units as indicated below.

- When connecting a spiral duct or an aluminum bellows, sound at the air discharge outlet is higher by 8~11 phon than the main body operating sound.
- When using this unit in a quiet place, take a remedy for sound by connecting an optional flexible duct at the outlet of the indoor air suction side of the main body.

10 Installation

10 - 2 Centralized piping

Wherever possible, avoid centralized OA and EA pipings for two or more HRV units, and install ducts for each body of the unit. (Fig. 2)

Because the air flow shown in Fig.1 is generated when centralized OA and EA pipings for two or more HRV units normal air flow cannot be maintained. If a back flow prevention damper is installed in the duct on OA and EA side of each HRV units (Fig.3), costs will increase as compared with the case a duct is installed for each body. It is therefore recommended that a duct be installed for each body. (Before installing the back flow prevention damper, contact our engineering section.)

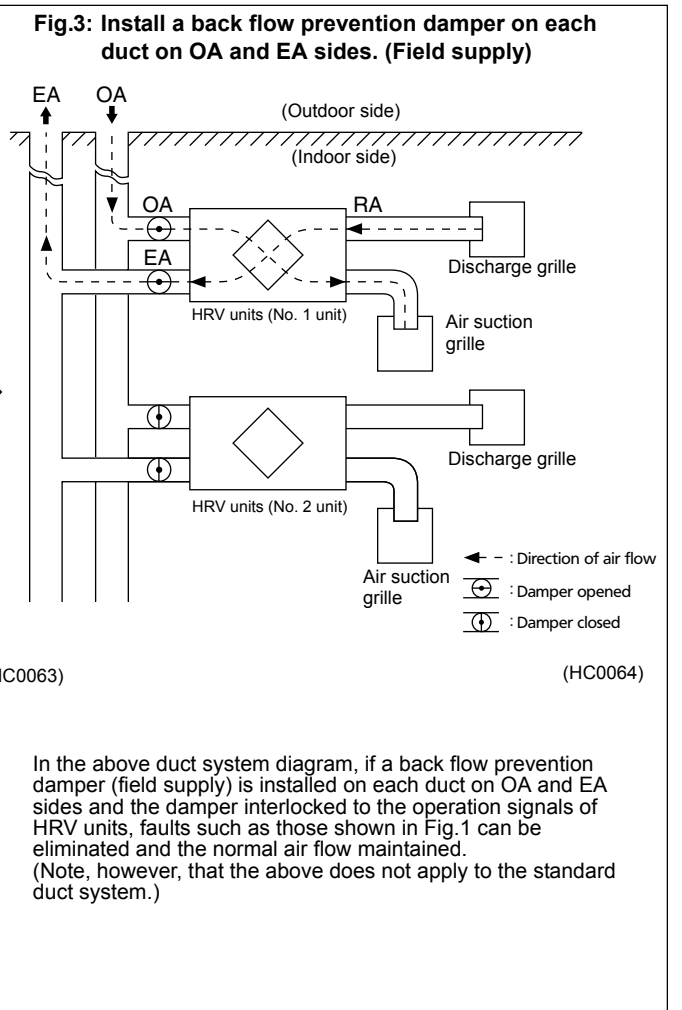
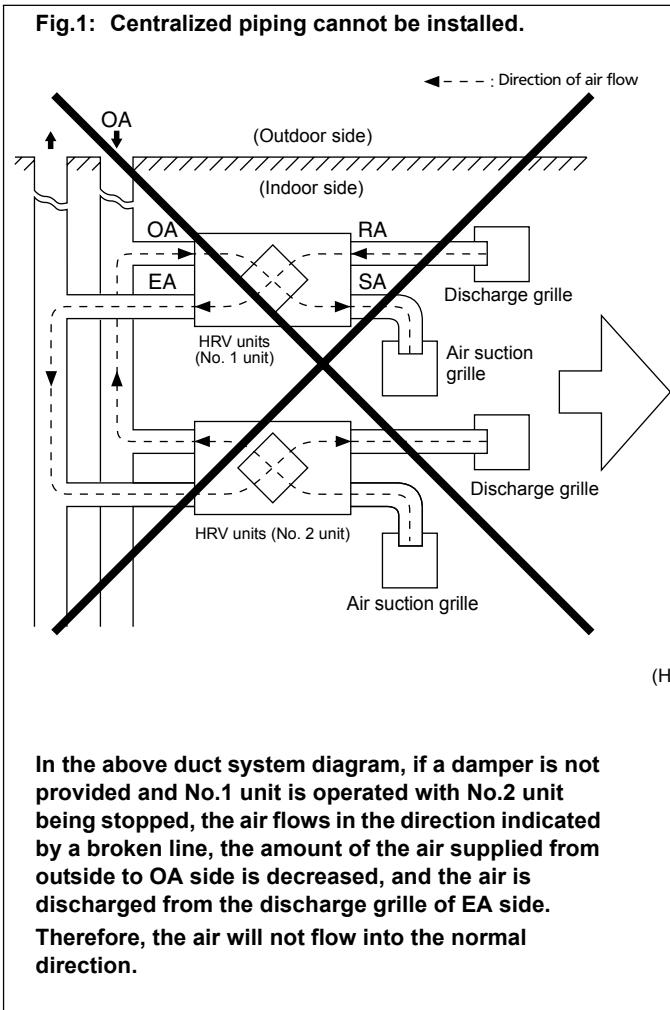
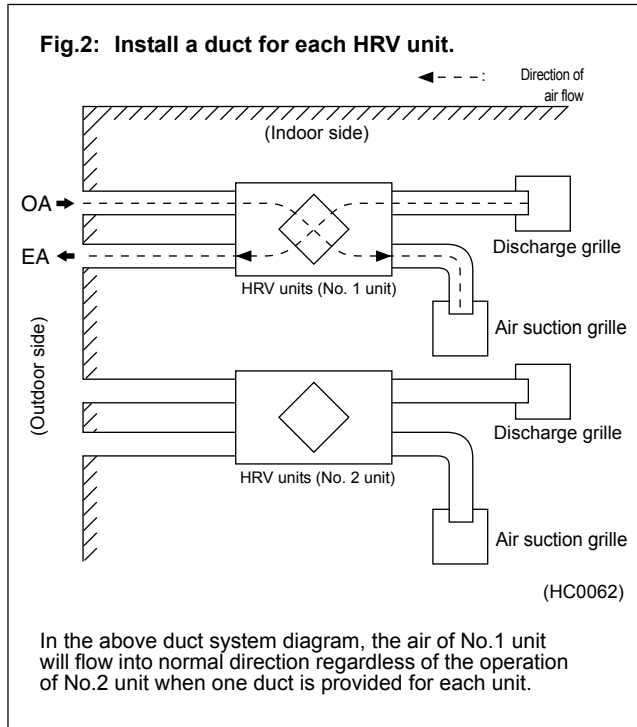

10 Installation

10 - 3 Cautions

1. Install the unit on a rigid and stable place. Refer to the specification and weight of the unit.

Use suspension bolts for installation. Confirm that the place for installation can stand the weight of the unit. If not, reinforce the place with beams, etc. and install the suspension bolts. If the strength of the place for installation is not sufficient, the place resonates to the vibration of the unit and abnormal noise may be transmitted.

2. Install a service space and an inspection hole. Refer to the outline drawing for details.

Be sure to provide a service space and an inspection hole for inspection of air filter, heat exchange element and fan. HRV units require one inspection hole.

3. Bellows may not be able to use depending on the local regulations. (In the case in Japan)

Some local regulations may not allow the use of bellows in view of the safety for fire prevention. Before using the bellows, contact administrative agencies or fire department in your district. Note that bellows are not allowed in Tokyo in accordance with the Fire Prevention Act of Tokyo.

4. When exhausting air into the centralized duct (vertical hole), install a riser duct of steel plate of over two meters long inside the vertical hole or install an approved smoke back flow prevention damper. (In the case in Japan)

When exhausting air into centralized duct (vertical hole), the Building Standards Act requires that the duct must be capable of preventing fire from expanding through the duct should a fire break out.

When a riser duct of steel plate of 2 m long is installed

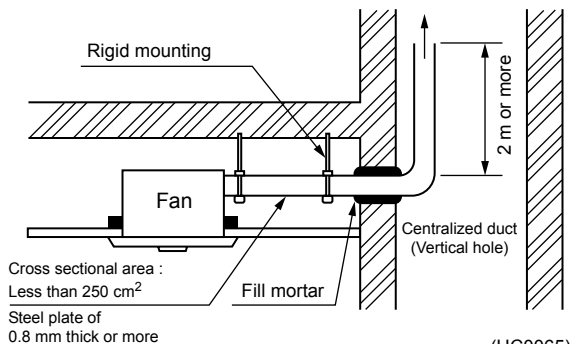

(HC0065)

When a smoke back flow prevention damper is installed

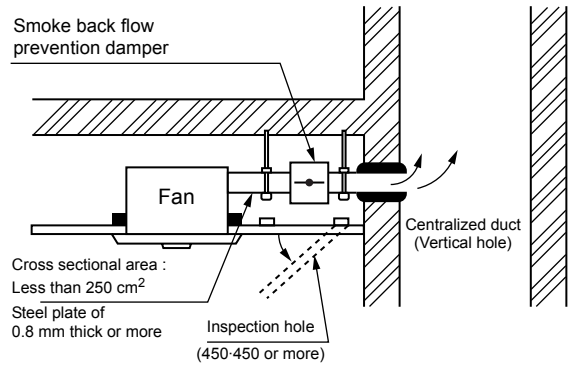

(HC0066)

Caution

- Installing a 2 m exhaust duct in a centralized duct involves difficulty in construction and maintenance, and is not practised generally. In actual installation, the approved smoke back flow prevention damper is used, Use Daikin's optional smoke back flow prevention damper.

5. Air filters are provided on the air intake side and exhaust air side. Be sure to install these filters.

Air filter cleans the air and prevents clogging of the element, and must be installed properly.

6. Confirm the using conditions of HRV units before installation.

Ambient conditions for use: -10°C to 50°CDB at 80% RH or less

Outdoor air temperature condition

When used below -10°C , indoor air temperature varies greatly from outdoor air temperature and frost may form on the heat exchange element depending on conditions of temperature and humidity. Further, the frost formation may be frozen. The frozen frost melts during the day as the temperature rises but the heat exchange efficiency drops before the frozen frost is melted.

As a countermeasure, preheating of the air on low temperature side is considered.

In a place where the temperature exceeds 50°C , deformation of resin parts such as air filter and reduced life of motor and electric parts due to deteriorated insulation are considered.

7. The precise available conditions are shown below.

Conditions:

Ambient temperature & humidity for HRV unit	-10°C to 50°CDB 80% RH or less
Indoor / Outdoor air	-10°C to 43°CDB The relative humidity [% RH] is as described below

10 Installation

10 - 3 Cautions

- 1) Operation in highly humid areas (in cooling mode)
To prevent dew formation, use the unit under the condition that the indoor discharge air is 95% RH or less on the psychrometric chart.

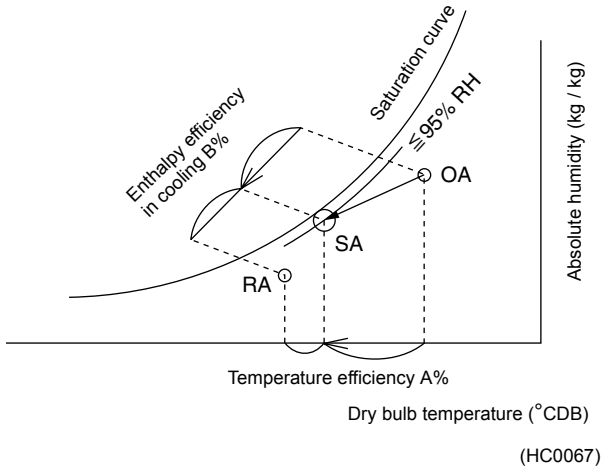
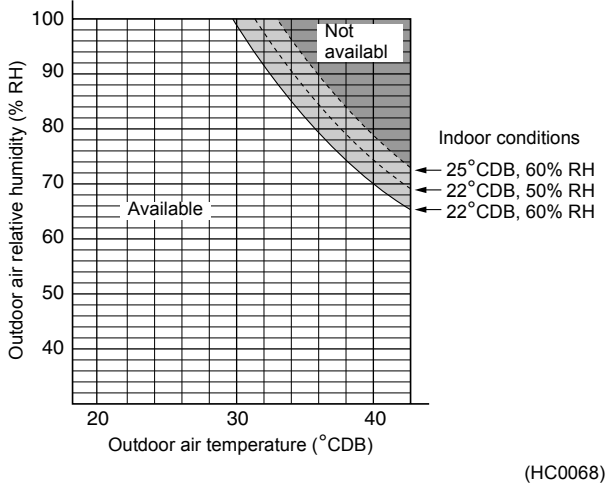

Fig.1 shows the limit under normal indoor conditions.

Fig.1 Conditions:
 Temperature efficiency A = 72%
 Enthalpy efficiency B = 56% (In cooling)
 This conditions are at the minimum efficiency that are the severest to dew formation.



(HC0068)

- 2) Operation in cold areas (in heating mode)
To prevent dew formation and freezing, use the unit under the conditions that the outdoor discharge air is 95% RH or less on the psychrometric chart.

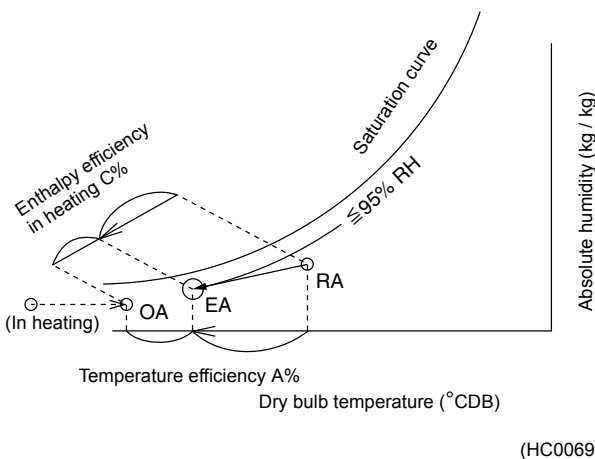

(HC0069)

Note:

If the outdoor discharge air exceeds 95% RH, please preheat the outdoor suction air before it goes through the heat exchanger.

8. Do not use HRV units where the air contains noxious gas and corrosive components of materials such as acid, alkali, organic solvent, carbon black and paint. Also, do not use in a place where damage from sea wind and hot spring prevail or where air containing odor is recovered for supply to other locations.

9. Do not operate HRV units in [Bypass] ventilation mode when the indoor is heated during winter.

Such operation may cause frost to form in the body and dirty ceiling may result.

10. When a unit is installed on the ceiling using short suspension bolts, abnormal noise may be generated due to resonance with the ceiling.

Provide resonance preventive measures for the body suspension bolts.

Example

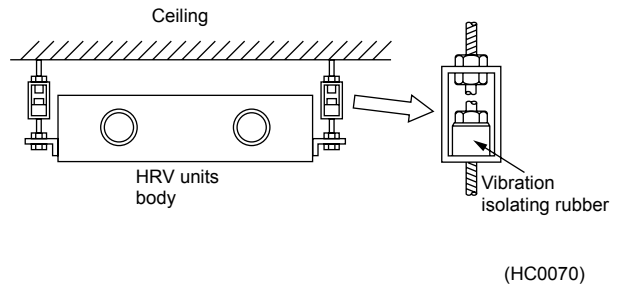

(HC0070)

If abnormal noise is suspected generating from a spiral duct connection, change the duct to flexible duct. The above preventive measure is considered to eliminate the problem (resonance) but contact our service group and provide means to prevent vibration or necessary changes of the motor of the unit body.

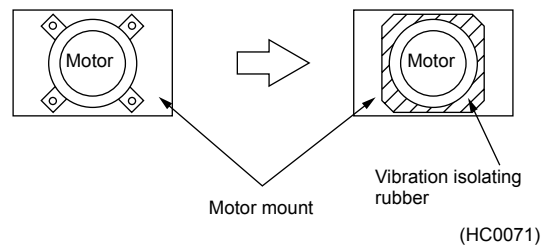

(HC0071)

Caution

- When the outdoor air infiltrates into the ceiling and the temperature and humidity in the ceiling become high, insulate the metal part of the unit.

10 Installation

10 - 4 Cautions in installation

Do not use a HRV or an air suction / discharge grille in the following places.

- Place such as machinery plant and chemical plant where gas, which contains noxious gas or corrosive components of materials such as acid, alkali, organic solvent and paint, is generated. Place where combustible gas leakage is likely.
Such gas can cause fire.

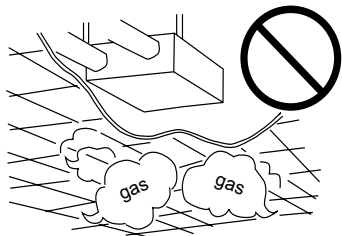

(HC0072)

- Place such as bathroom subjected to moisture.
Electric leak or electric shock and other failure can be caused.

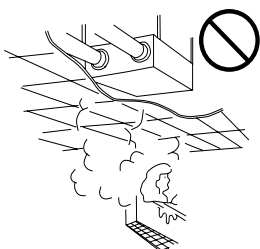

(HC0073)

- Place subjected to high temperature or direct flame.
Avoid a place where the temperature near the HRV unit and the air suction / discharge air grille exceeds 40°C. If the unit is used at high temperature, deformed air filter and heat exchange element or burned motor result.

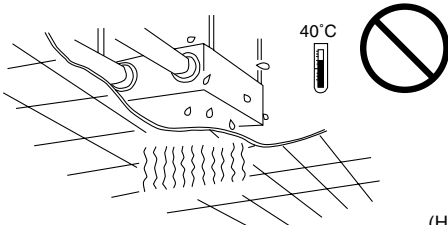

(HC0074)

- Place subjected to much carbon black.
Carbon black attaches to air filter and heat exchange element, marking them unable to use.

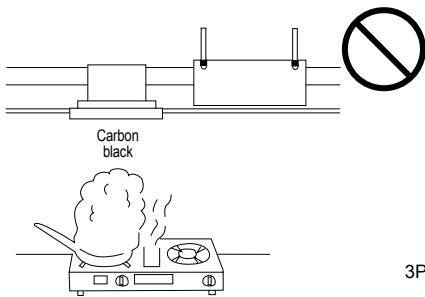

(HC0075)
3P034927-2B

10 - 5 Installation

10-5-1 Installation of HRV units

- Install the anchor bolt (M10 to 12) in advance.
Pass the ceiling suspension fixture through the anchor bolt and secure the anchor bolt with washer and nut. (Before installation, check for foreign objects such as vinyl and paper remaining inside the fan housing.)
- The ceiling suspension fixture is fitted on top of the standard unit. If the anchor bolt is long, install it on the bottom of the unit. (Be sure to screw in the removed mounting screw on top to prevent air leakage.)

Install the duct caution name plate properly on the indoor side (SA·RA) and outdoor side (EA·OA).

VAM150-1000FA

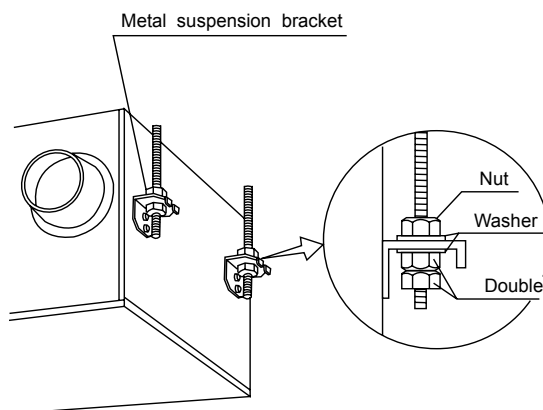

VAM150,2000FA

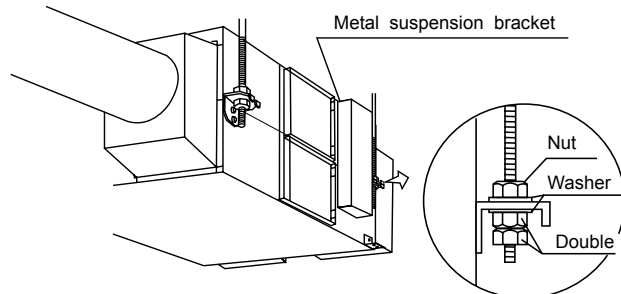

(HC0076)

Note:

Remove the clamp (at two locations) for securing the unit in transit, if it prevents installation work. (Be sure to screw in the removed mounting screw on the body side to prevent air leakage.)

10 Installation

10 - 6 Duct Work

10-6-1 Caution

- Do not install ducts as shown below.

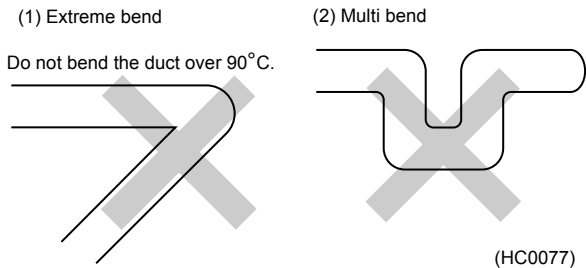

- (3) Reduce the diameter of the duct to be connected.

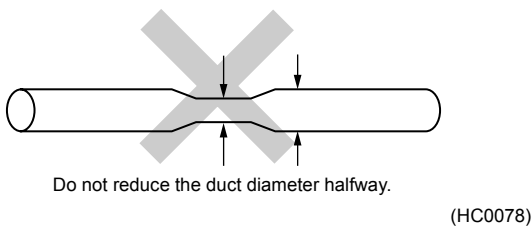

- To prevent air leakage, wind aluminum tape round the section after the duct connecting flange and the duct are connected.
- Install the opening of the indoor air intake as far as from the opening of the exhaust suction.
- Use the duct applicable to the model of unit used (Refer to the outline drawing.)
- Install the two outdoor ducts with down slope (slope of 1 / 50 or more) to prevent entry of rain water. Also, provide insulation for both ducts to prevent dew formation. (Material: Glass wool of 25 mm thick)

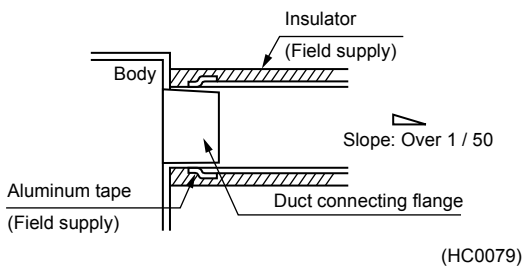

- If the level of temperature and humidity inside the ceiling is always high install a ventilation equipment inside the ceiling.
- Insulate the duct and the wall electrically when a metal duct is to be penetrated through the metal lattice and wire lattice or metal lining of a wooden structure wall.

10-6-2 Going through the external wall

1. Hole diameter

Duct dia. + 50 or 75
(I.D. depends on the core drill specification)

<e.g.>

Duct diameter	Hole diameter
$\phi 100 + 50$	$\phi 150$
$\phi 150 + 50$	$\phi 200$

2. Drilling the hole

Ideally it is better to grade in the same procedure as refrigerant piping.

In the case of a square duct
Grade a wood frame of a duct stay.

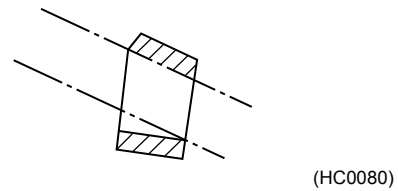

In the case of a round duct

Drill a hole horizontally because the hole cannot be made with the tool graded.

3. Preventing wind and rain from entering

Most of a space between the duct and the external wall is protected by mortar. Coated wall is filled with a caulking material. (See fig. 1)

Image picture

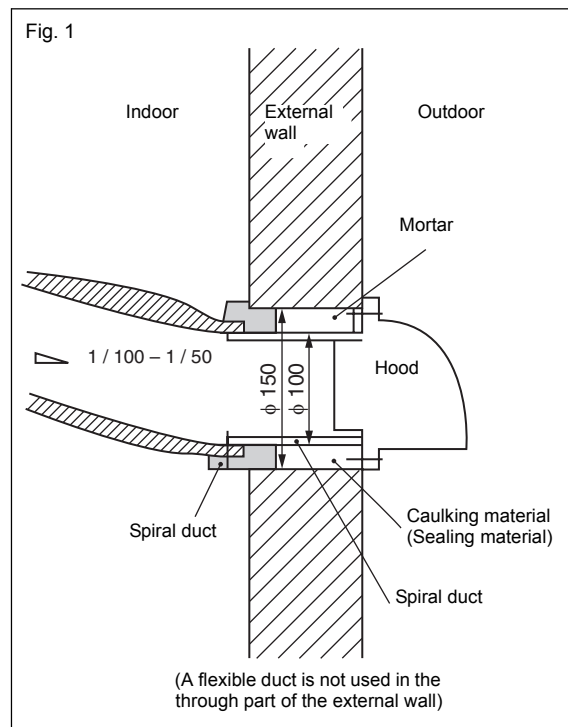

4. How about the building which has already been built?

Same as the newly-built building.

- Only hole diameter 100 is instructed in a drawing by a drawing company, so a detailed work is executed by the judgement of an installation company.

10 Installation

10 - 7 Electrical wiring procedure

▲ Before obtaining access to terminal devices, all power supply circuits must be interrupted.

Connection of Wiring

- Connect the wires in accordance with the diagram of each system.
- All wiring must be performed by an authorized electrician.
- All field supplied parts and materials and electric works must conform to local codes.
- Use copper wire only.

Connection of wiring

- A circuit breaker capable of shutting down supply to the entire system must be installed.
- A single switch can be used to supply power to units on the same system. However, branch switches and branch circuit breakers must be selected carefully.
- Fit the power supply wiring of each unit with a switch and fuse as shown in the drawing.
- Be sure to give the electric grounding (earth) connection.

Complete System Example

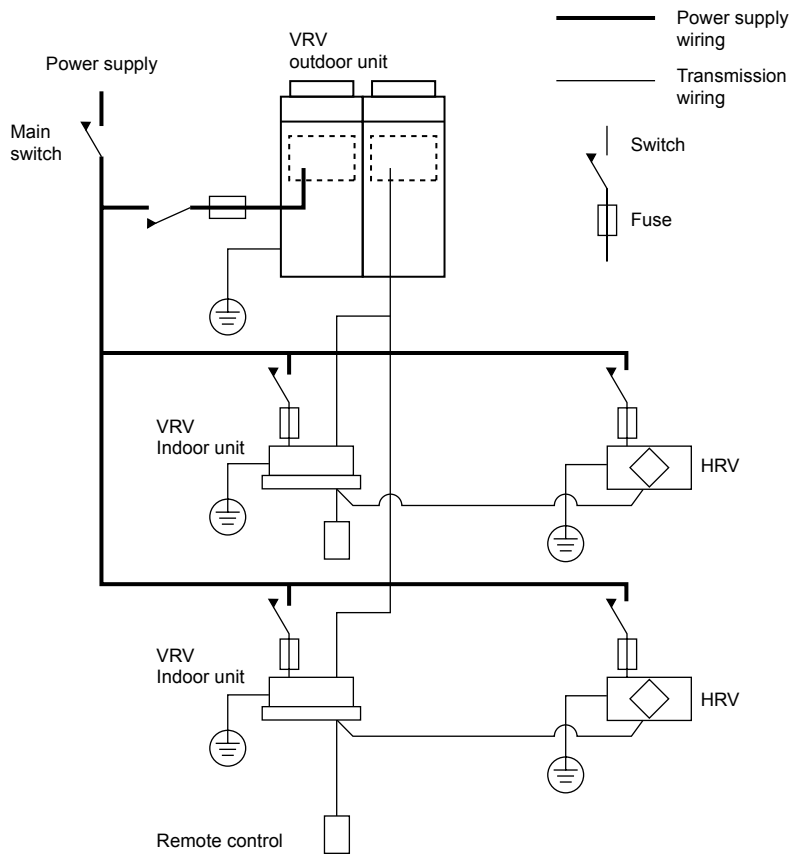

(HC0082)

Model	Type	Power supply wiring			Transmission wiring	
		Field supplied fuses	Wire	Size	Wire	Size
VAM150FA	VE	15A	H05VV-U3G	Wire size must comply with local codes.	Shield wire (2 wire)	0.75 ~ 1.25 mm ²
VAM250FA						
VAM350FA						
VAM500FA						
VAM650FA						
VAM800FA						
VAM1000FA						
VAM1500FA						
VAM2000FA						

(HC0083)

10 Installation

10 - 7 Electrical wiring procedure

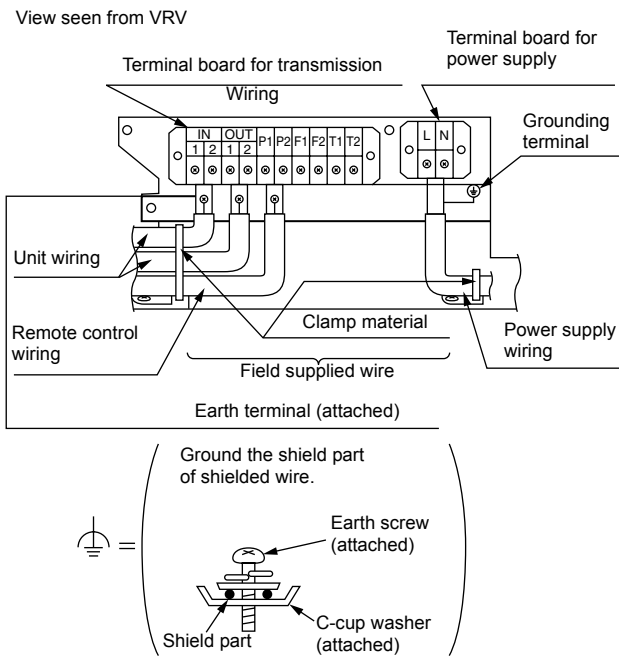

(HC0084)

▲PRECAUTIONS

1. Do not connect wires of different gauge to the same power supply terminal. Looseness in the connection may cause overheating. When connecting more than one wire to the power supply wiring, use a 2 mm² (φ 1.6) gauge wire.

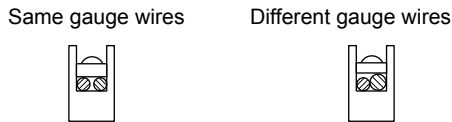

2. Keep total current of crossover wiring between indoor units less than 12 A. When using two power wiring of gauge greater than 2 mm² (φ 1.6), branch the line outside the terminal board of the unit in accordance with electrical equipment standards. The branch must be sheathed so as to provide an equal or greater degree of insulation as the power supply wiring itself.
3. Do not connect wires of different gauge to the same grounding terminal. Looseness in the connection may deteriorate protection.
4. Keep the power supply wiring distant from other wires to prevent noise.
5. For remote control wiring, refer to the "INSTALLATION MANUAL OF REMOTE CONTROL".

Wiring Example

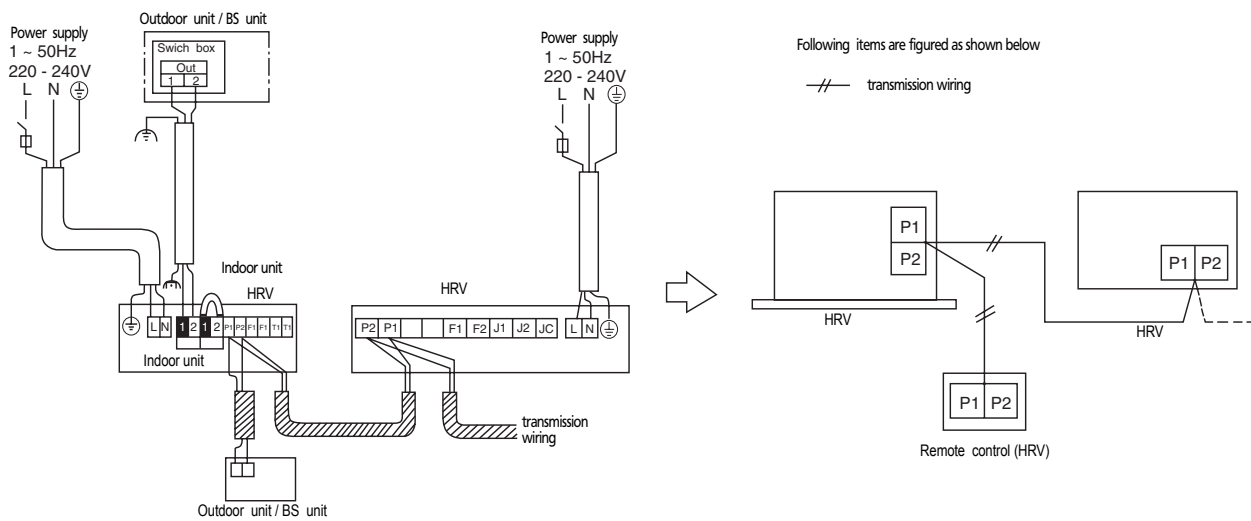

(HC0085)

- All transmission wiring except for the remote control wires is polarized and must match the terminal symbol.
- Use screened wire in transmission wiring. Ground the shield of the shield wire to "⊕", at the grounding screw, with the C-cup washer.
- Sheathed wire materials may be used for transmission wiring, but they are not suitable for EMC (Electromagnetic Compatibility) (European Directive).
- When using sheathed wire, electromagnetic compatibility must conform to Japanese standards stipulated in the Electric Appliance Regulatory Act. Transmission wiring need not be grounded when using sheathed wire.

10 Installation

10 - 7 Electrical wiring procedure

10-7-1 Opening the switch box

VAM150-1000FA

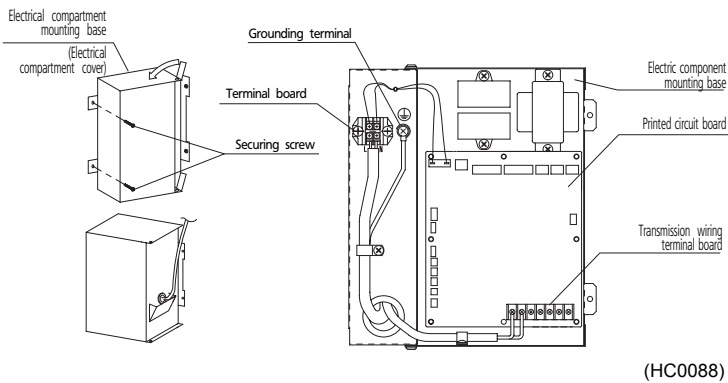

VAM1500,2000FA

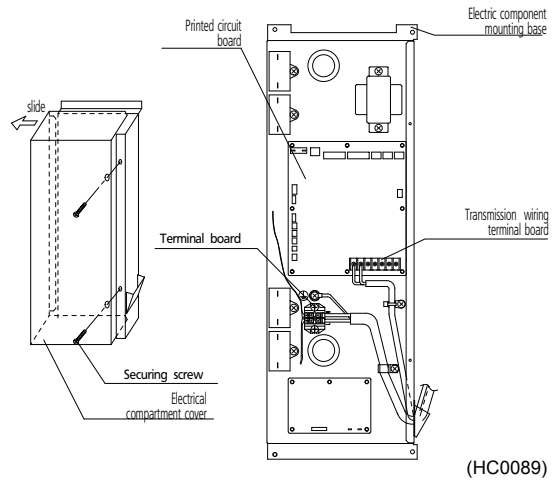

- ▲ Before opening the cover, be sure to turn off the power switches of the main units and other devices connected with the main units.
- Remove the screw securing the cover and open the switch box.
 - Secure the power cord control wires with the clamp, as shown above.

10-7-2 How to install the optional adapter circuit board

1. Open the electrical compartment cover by following the procedure described in the “Opening the switch box” section.
6. Remove the securing screw, and install the adapter circuit board.
7. After the wires are connected, fasten the electrical compartment cover.
(For detail, refer to 6. Optional accessories.)

10-7-3 Wiring system of centralized transmission control wiring

Total length of wiring should not exceed 1000 m.

Series wiring

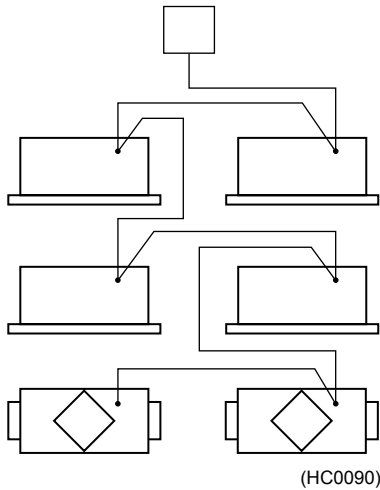

(Can be connected up to 8 branches)

Bus type wiring

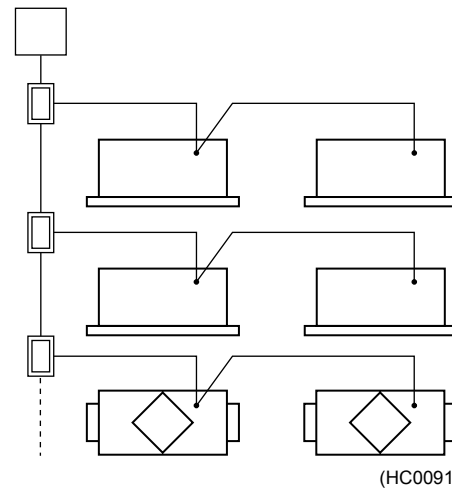

(HC0091)

Star type wiring

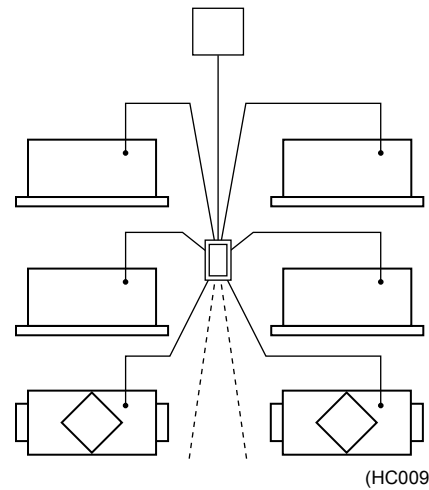

(Can be connected up to 8 branches)

Cautions:







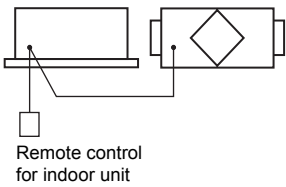
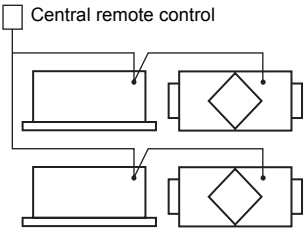
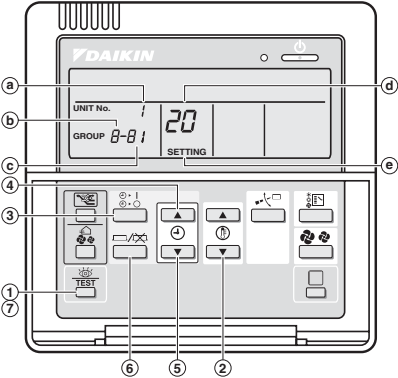

- The bus type wiring and the star type wiring cannot be used at the same time.
- Do not connect more than 3 wires to the same terminal.
- If necessary, use a relay terminal (field supply).

In this technical manual, all the schematic drawings is shown by the series wiring, which do not require relay terminals.

10 Installation

10 - 8 Initial setting

10-8-1 Initial setting by the remote control for indoor unit

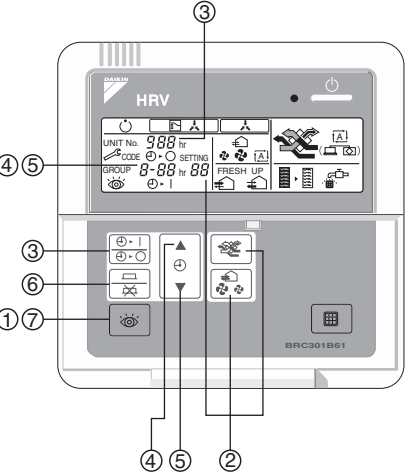
Purpose	Controller	Operating procedure for initial setting
<ul style="list-style-type: none"> Interlocked operation  <p>Remote control for indoor unit</p> <ul style="list-style-type: none"> When only the centralized controller is used.  <p>Central remote control</p>	<ul style="list-style-type: none"> Remote control for indoor unit 	<p>The following describes the operating procedure and settings.</p> <ol style="list-style-type: none"> When in the normal mode, press the “” button for a minimum of four seconds, and the FIELD SET MODE is entered. Select the desired MODE NO. with the “” button. During group control, when setting by each indoor unit (mode No. 20, 21, 22 and 23 have been selected), push the “” button and select the INDOOR UNIT NO. to be set. (This operation is unnecessary when setting by group.) Push the “” upper button and select FIRST CODE NO. Push the “” lower button and select the SECOND CODE NO. Push the “” button once and the present settings are SET. Push the “” button to return to the NORMAL MODE.
	<ul style="list-style-type: none"> BRC301B61 	<p>The following describes the operating procedure and settings.</p> <ol style="list-style-type: none"> Press the INSPECTION button for more than four seconds to enter the local setting mode when the unit is in the normal mode. Use the VENTILATION MODE, AIR FLOW RATE button to select the desired “mode number”. (The code display will blink.) To make setting for individual unit under group control (when mode no. 27, 28 or 29 is selected), press TIMER SETTING ON / OFF button to select the “unit No.” for which the settings are to be made. (This process is not necessary when settings are made collectively for the group.) Press the top section of the TIMER button to select the “setting switch No.”. Press the lower section of the TIMER button to select the “setting position No.”. Press the PROGRAM / CANCEL button once to enter the settings. (The code display will stop blinking and light up.) Press the INSPECTION button to return to normal mode.

Note:
When you make several field settings to one (or one group of) indoor unit(s), the item ② to ⑥ of the above setting procedure should be repeated and it should be terminated to the “normal display” by the procedure of item ⑦ as last.







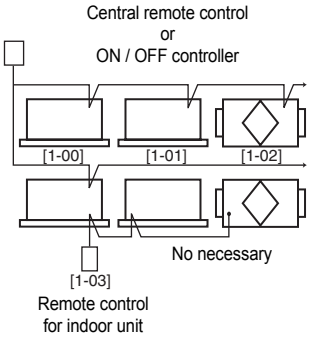
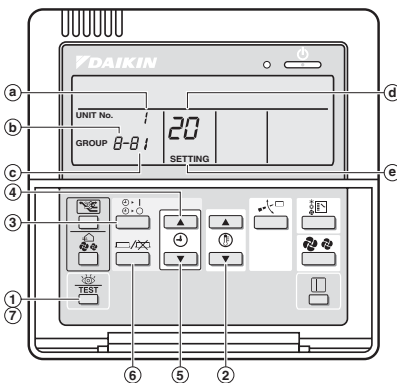

(HC0093)

10 Installation

10 - 8 Initial setting

10-8-2 Setting procedure of group no. for centralized control

The following shows the procedure how to set the group number for the centralized control by the remote control for indoor unit

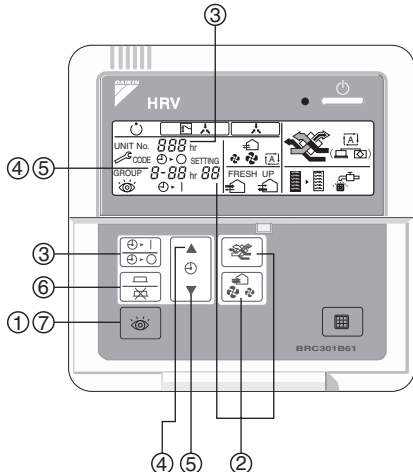
Purpose	Control	Operating procedure
<p>When you use the central remote controller and the unified On / Off controller, you have to set the each unit connected to the central transmission line.</p> <p><Example></p> 	<p>• Remote control for indoor unit</p> 	<p>The following describes the operating procedure and settings.</p> <ol style="list-style-type: none"> ① When in the normal mode, press the “ TEST” button for a minimum of four seconds, and the FIELD SET MODE is entered. ② Select the desired MODE NO. with the “” button. ③ During group control, when setting by each indoor unit (mode No. 20, 21, 22 and 23 have been selected), push the “” button and select the INDOOR UNIT NO. to be set. (This operation is unnecessary when setting by group.) ④ Push the “” upper button and select FIRST CODE NO. ⑤ Push the “” lower button and select the SECOND CODE NO. ⑥ Push the “” button once and the present settings are SET. ⑦ Push the “ TEST” button to return to the NORMAL MODE.
	<p>• BRC301B61</p> 	<p>The units in [] do not require the group no. setting for the centralized controller connected to the central transmission line. (Auto-address setting)</p> <ol style="list-style-type: none"> ① Press the INSPECTION button for more than four seconds. ② Use the VENTILATION MODE, AIR FLOW RATE to select the mode no. “00”. ③ Use the top or lower section of the TIMER button to set the group no. for the centralized controller. (When you use the unified ON / OFF controller, it displays only the group no. selected by the setting switch for zone control.) ④ Press the PROGRAM / CANCEL button to enter the setting group no. shown on the display. ⑤ Press INSPECTION button to return to normal mode.

Notes:

Do not duplicate the group number.
Be sure to supply the power to the remote control side.
(It cannot be set without the power supply.)

(HC0094)

10 Installation

10 - 8 Initial setting

10-8-3 Initial setting for “Central zone control”

When HRV unit is connected to the central transmission line (terminal connector no. (F1) and (F2)), it is necessary to make an initial setting of “collective zone interlock” by the remote control for indoor unit. (Factory set “OFF”.)
 Make initial setting as follows.

Combination with central control

Central control ○: Possible ×: Impossible

Central control				Operation · function		Initial setting for “central zone control”
Multi-function centralized control	Unified ON / OFF control	Schedule timer	Adapter PCB for remote control	Interlocked operation (Automatic selection)	Independent operation / stop (By central control)	
1 unit	—	—	—	○	×	ON
				×	×	OFF
1 unit	1 – 4 units	—	—	○	×	ON
				×	○	OFF
1 unit	—	1 unit	—	○	×	ON
				×	×	OFF
1 unit	1 – 4 units	1 unit	—	○	×	ON
				×	○	OFF
—	1 – 4 units	—	—	It is impossible to operate.		ON
				×	○	OFF
—	—	1 unit	—	It is impossible to operate.		ON
				×	○	OFF
—	—	1 unit	—	○	×	ON
				×	X (Only collective operation)	OFF
—	—	—	1 unit	○	×	ON
				×	X (Only collective operation)	OFF

Cautions

When you make an initial setting “ON”, the interlocked operation has a priority, and it is impossible to operate / stop HRV unit independently by the central remote control or the unified On / Off control. If there is no indoor unit for interlocked operation in the same zone, make an initial setting “OFF”.

When you make an initial setting “OFF”, the independent operation of HRV unit has a priority, and the interlocked operation is not possible.

When the HRV unit is operated independently by the central control, the HRV unit will not operate until the preset time elapses if the precool / preheat time setting is set. Therefore, please do not set the precool / preheat time setting in normal operation.

Example of system

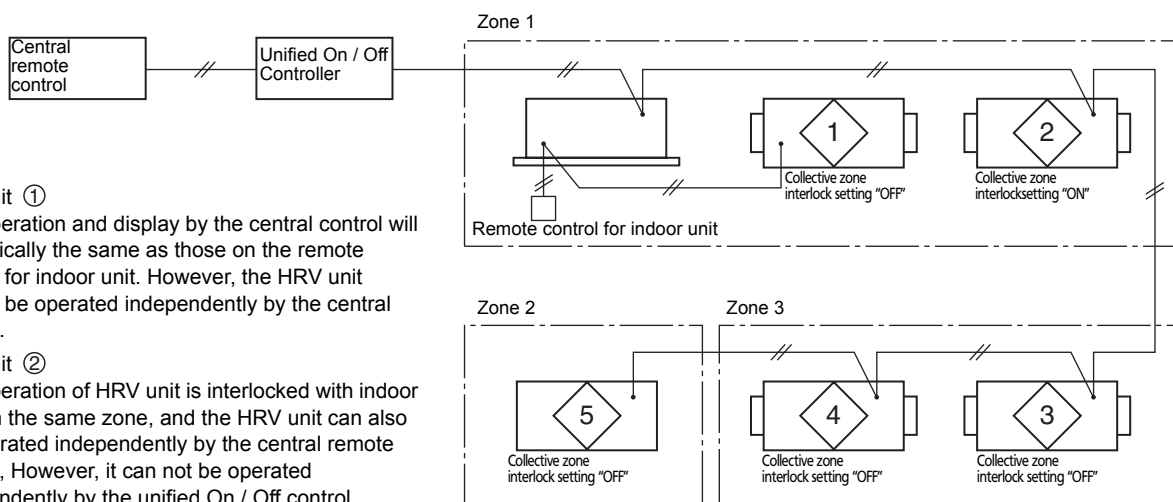

(HC0095)

The unit ①

The operation and display by the central control will be basically the same as those on the remote control for indoor unit. However, the HRV unit cannot be operated independently by the central control.

The unit ②

The operation of HRV unit is interlocked with indoor units in the same zone, and the HRV unit can also be operated independently by the central remote control. However, it can not be operated independently by the unified On / Off control.

The unit ⑤

When the central remote control is used, each unit will be one zone, unless you set the zone for plural units.

In all of us,
a green heart



Daikin's unique position as a manufacturer of air conditioning equipment, compressors and refrigerants has led to its close involvement in environmental issues. For several years Daikin has had the intention to become a leader in the provision of products that have limited impact on the environment. This challenge demands the eco design and development of a wide range of products and an energy management system, resulting in energy conservation and a reduction of waste.



VRV® products are not within the scope of the Eurovent certification programme.

The present publication is drawn up by way of information only and does not constitute an offer binding upon Daikin Europe N.V. Daikin Europe N.V. has compiled the content of this publication to the best of its knowledge. No express or implied warranty is given for the completeness, accuracy, reliability or fitness for particular purpose of its content and the products and services presented therein. Specifications are subject to change without prior notice. Daikin Europe N.V. explicitly rejects any liability for any direct or indirect damage, in the broadest sense, arising from or related to the use and/or interpretation of this publication. All content is copyrighted by Daikin Europe N.V.

Daikin products are distributed by: